

# CONFIDENTIAL

## Improving the usability & manufacturability of a novel forensic nail collector

by

Olaf Dassing

to obtain the degree of Master of Science  
at the Delft University of Technology,  
to be defended publicly on Wednesday April 3, 2019 at 02:00 PM.

Student number:	4111745	
Project duration:	May, 2018 – April, 2019	
Thesis committee:	dr. ir. Arjo Loeve,	TU Delft, supervisor
	prof. dr. Jenny Dankelman,	TU Delft
	dr. ir. Dick Plettenburg,	TU Delft
	ing. Marcel van Beest,	NFI

*This thesis is confidential and cannot be made public until December 31, 2024.*

An electronic version of this thesis is available at <http://repository.tudelft.nl/>.



# Contents

<b>i Abstract &amp; thesis structure</b>	<b>1</b>
<b>1 Design Report: Improving the design of a novel forensic nail collector</b>	<b>3</b>
1.1 Introduction	3
1.1.1 Current forensic nail collector design	3
1.1.2 Assembly methods	4
1.1.3 Potential improvements	4
1.1.4 Redesign goals	5
1.2 Design criteria	5
1.2.1 Existing design criteria	5
1.2.2 New design criteria	6
1.3 Concepts: Designing an improved and easier to manufacture forensic nail collector	7
1.3.1 Concepts: Preventing the top jaw from rotating	7
1.3.2 Concepts: Removal of the coil spring	7
1.4 Weighted objectives table: Best cutting jaw concept	10
1.5 Conceptualization: Single component cutting jaw	10
1.5.1 AngleVue cutting jaw	10
1.5.2 Prototype production	11
1.5.3 Rejection of the single-component cutting jaw concept	12
1.6 Conceptualization: Rotation prevention in handle connection	12
1.7 Conceptualization: Leaf spring retainer	13
1.7.1 Injection moldable leaf spring retainer	13
1.7.2 Required spring force	14
1.7.3 Spring stiffness analysis with Ansys	14
1.7.4 Insert-molded leaf spring retainer alternative	15
1.7.5 Improving the manufacturability and usability of the cutting jaw	17
1.8 Improving the manufacturability of the handles	18
1.8.1 Production methods of the current forensic nail collector handles	18
1.8.2 Testing each stability element with 3D printed top handle prototypes	18
1.8.3 Changes to the design of the handles	19
1.9 Renewed forensic nail collector design	20
1.10 Further recommendations	20
<b>2 Research Paper: Testing the usability of a novel tool for forensic nail cutting</b>	<b>23</b>
<b>Bibliography</b>	<b>33</b>
<b>A Usability experiment documents</b>	<b>35</b>
A.1 Usability experiment forms	35
A.2 Instruction video screenshots	41
<b>B Technical drawings: Renewed forensic nail cutter</b>	<b>43</b>
<b>C Leaf spring retainer</b>	<b>53</b>
C.1 Protolabs: automated design analysis of the spring retainers	53
C.2 Spring stiffness analysis with Ansys AIM 19.0	55
C.3 Technical drawings: Improved cutting jaw	55
<b>D Drop experiment</b>	<b>61</b>





# Abstract & thesis structure

## Abstract

### Background

In forensic cases DNA and other trace evidence underneath the nails of victims can be crucial for finding and convicting the perpetrator. The victim's nails are cut and sent to the lab for forensic analysis. Current forensic nail cutting methods are prone to errors as nails can easily fall on the ground, contaminating potential evidence. Delft University of Technology is developing a specially designed forensic nail collector that cuts and stores the cut nail, preventing the nail clippings from falling on the ground.

### Methods

A previously developed forensic nail collector prototype was further improved. The instability of several parts of the forensic nail collector, difficulties to cut deep under the fingernail, sterilizability of the coil spring in the cutting jaw and the manufacturability of the forensic nail collector parts, were found as potential improvements. Twelve concept solutions were drawn up to improve the forensic nail collector. Unfortunately, a working simplification that removes the coil spring was not found. The three other potential improvements were successfully enhanced.

The improved forensic nail collector was tested during a user experiment. The goals of the experiment were to find out if participants were able to (dis)assemble the forensic nail collector with no or limited experience. And whether participants were able to cut nails faster and more easily from a hand clenching an object compared to a hand placed flat on the table. Nineteen participants disassembled and then reassembled the forensic nail collector ten times. Nine of the participants watched a (dis)assembly instruction video before the (dis)assembly experiment. During the second part of the experiment participants cut each others fingernails. One of the hands being cut was placed with the palm of the hand flat on the table and the other hand clenched a piece of pipe. A modified experiment was done with a forensic expert. A traditional forensic nail cutting method using scissors and tweezers was compared to nail cutting with the forensic nail collector. All participants and the forensic expert were asked to provide feedback through a questionnaire to further improve the forensic nail collector.

### Outcome

Participants that received instructions (dis)assembled the forensic nail collector faster and more consistent during the first five tries. During later tries both the 'instruction' and 'no instruction' group were almost equally fast. Participants were faster and found it easier to cut the nails from the hand clenching a piece of pipe, due to better visibility. The forensic expert was about 16% faster using the traditional forensic cutting method using scissors and tweezers. The ability to cut deep under the fingernail and the high hand force necessary to cut nails with the forensic nail collector were the most heard feedback points from the participants. Feedback from the participants was used to improve the forensic nail collector.

## **Thesis structure**

This thesis is divided in two chapters. Chapter 1 describes the design process with all improvements made to the previously developed forensic nail collector prototype. The improved forensic nail collector was tested during a user experiment with 19 participants. Chapter 2 contains a research paper, describing the methods and results of the user experiment with the improved forensic nail collector.

# Design Report: Improving the design of a novel forensic nail collector

## 1.1. Introduction

After crimes, important evidence may be left under the nails of a victim or suspect. Such evidence can consist of DNA, traces of paint or gunshot residues and may be crucial in finding or prosecuting a perpetrator[21]. Additionally nail clippings can be used for toxicologic analysis [12, 13, 17]. In order to collect as much of any traces under the nails as possible, the nails are swabbed [12] or scraped and then clipped [19, 22, 32]. The nail scrapings and clippings are sent to a lab for forensic analysis [15, 22].

With traditional forensic nail cutting methods, nails are cut with simple nail scissors or nail clippers shown in Figure 1.1. The nail sample is secured by tweezers when cut with nail scissors or caught on a piece of paper, or caught in a glove when cut with nail clippers [12, 22]. These current methods for collecting nail samples are prone to errors as nails can easily fall on the ground contaminating potential evidence.



Figure 1.1: Simple nail cutters or nail clippers currently used for forensic nail cutting [3].

### 1.1.1. Current forensic nail collector design

A specialized forensic nail collector is being developed by the department of BioMedical Engineering of Delft University of Technology, of which the latest prototype is shown in Figure 1.2. Important elements of the forensic nail collector are named in Figure 1.2. The forensic nail collector is developed to safely cut nails and store clipped nail samples in the retainer, is easy-to-use and prevents contamination of evidence.

Deceased bodies turn stiff due to rigor mortis and are sometimes found at a crime scene with a clenched fist [26, 30]. The forensic nail collector shown in Figure 1.2 is designed to make cutting nails from a clenched fist easier, by a relatively small cutting jaw that is placed with an offset under the

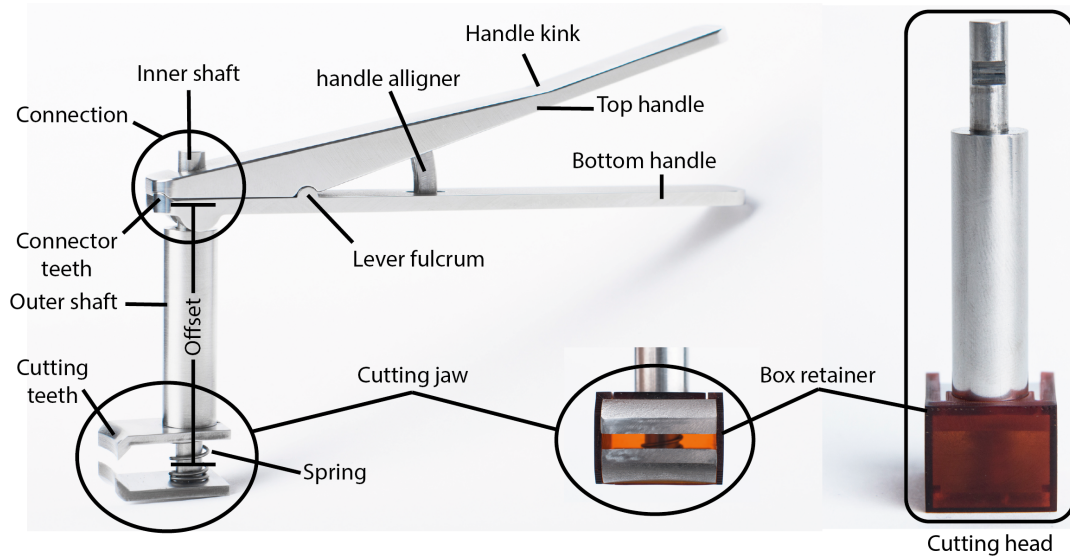

Figure 1.2: Latest forensic nail collector designed by previous TU Delft groups [1]. Parts and elements of the forensic nail collector are named with the name used throughout this report.

handles. The connector teeth, lever fulcrum and handle aligner provide rotational stability between the top and bottom handle of the forensic nail collector and are called the stability elements throughout this thesis. Without these rotational stability elements the top and bottom handle of the forensic nail collector would twist with respect to each other. The connection of the forensic nail collector is designed to be easily sterilized and cleaned as traces are not allowed to be transferred between crime scenes [7]. The connection of the forensic nail collector is also designed to be easy to (dis)assemble. The spring inside the cutting jaw of the forensic nail collector opens the cutting teeth and top and bottom handle after each cut. The box around the cutting jaw of the forensic nail collector retains the nail samples when cut.

### 1.1.2. Assembly methods

There are three methods to (dis)assemble the forensic nail collector seen in Figure 1.2:

1. **Rotation assembly:** The top handle is first connected to the cutting head. The bottom handle is placed between the top handle and the outer shaft at an angle relative to the top handle. The bottom handle is then rotated parallel below the top handle to fully assemble the forensic nail collector, see Figure 1.3.
2. **Click assembly:** The top handle is first connected to the cutting head. The bottom handle is now clicked between the outer shaft of the cutting head and the top handle to fully assemble the nail collector, see Figure 1.3. This assembly method was explained in the instruction video during the usability experiments discussed in Chapter 2.
3. **Bottom-handle-first assembly:** The bottom handle is first placed on top of the outer shaft of the cutting head. The top handle is now slit over the bottom handle on the cutting head. This method to assemble the forensic nail collector is more difficult than the previous two assembly methods discussed, as the rotational stability elements (connector teeth, lever fulcrum and handle aligner) do not allow the top and bottom handle to slide easily on top of each other. However, this method was used by multiple participants during the (dis)assembly experiment discussed in Chapter 2.

### 1.1.3. Potential improvements

There are four potential improvements to the forensic nail collector, found through cutting the authors own fingernails, experiments (see Chapter 2) and described in reports from previous TU Delft project groups [1, 18, 31]:

1. **Refrain top cutting tooth from rotating:** When cutting the authors own fingernails with the forensic nail collector prototype shown in Figure 1.2 it became clear that the cutting jaw is not able to cut fingernails efficiently. The top and bottom cutting teeth from the cutting jaw in Figure

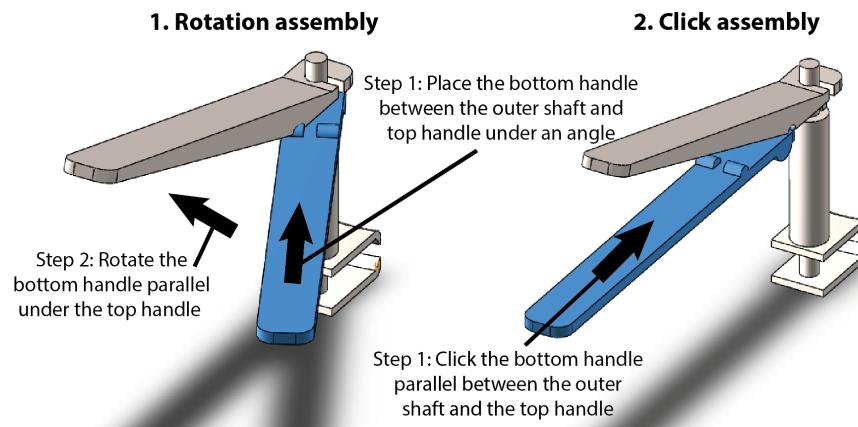

Figure 1.3: The rotation and click assembly method visualized.

1.2 are able to rotate relative to each other. Because of this rotation the two cutting teeth do not cut parallel on top of each other resulting in inefficient cutting forces. The box retainer around the cutting jaw was intended to restrict the top cutting tooth from rotating. However, the box retainer around the cutting jaw is not strong enough to completely refrain the top cutting tooth from rotating with respect to the bottom cutting tooth.

2. **Replacement for the coil spring:** Another potential improvement to the forensic nail collector is removal of the small coil spring in the cutting jaw, see Figure 1.2. During a cutting action both handle pieces and the cutting teeth are moved closer together compressing the spring. The spring re-opens the cutting teeth and handle pieces for the next cutting action. However, springs are difficult to sterilize. The spring is also a small part that is easily lost during the sterilization process. Furthermore, nail samples can get stuck between the coils of the spring and the shaft connected to the lower cutting tooth of the forensic nail collector. Ideally the coil spring is removed from the forensic nail collector and replaced with a mechanism that functions similar to the spring, but is easier to sterilize or disposable.
3. **Manufacturability:** The forensic nail collector shown in Figure 1.2 was expensive (€1899.42) to manufacture as a prototype. The handles are expensive to manufacture as many small milling operations are necessary to produce the handle pieces. The handles and cutting head design should be simplified to reduce manufacturing costs.
4. **Cutting teeth height and radius:** From experiments (see Chapter 2) and cutting the authors own fingernails it became clear that it was difficult to cut deep under the fingernail. To collect all evidence from under the fingernail it is important to cut under the fingernail as deep as possible. From experiments it also became clear that with the forensic nail collector it is more difficult to cut fingernails in one large piece compared to other nail clippers. Cutting teeth of normal nail clippers shown in Figure 1.1 have a smaller radius that make it easier to cut fingernails in larger pieces. To lower prototyping costs the cutting teeth of the current forensic nail collector were cut from a stainless steel flange. The shape of the flange defines the height and radius of the cutting teeth of the current forensic nail collector prototype.

#### 1.1.4. Redesign goals

The goal of the redesign project was to eliminate the top cutting tooth from rotating to improve cutting with the forensic nail collector. The spring in the cutting jaw should ideally be removed as the coil spring is difficult to sterilize. The goal was to incorporate the spring with another part of the forensic nail collector, like the box or the cutting teeth. Another goal is to simplify all parts of the forensic nail collector where possible to reduce the number of manufacturing steps and costs.

## 1.2. Design criteria

### 1.2.1. Existing design criteria

A detailed list of existing design criteria for the forensic nail collector were established by previous project groups from Delft University of Technology [18, 31]:

1. **Cut nails from a clenched fist:** As a result of rigor mortis victims are sometimes found with a firmly clenched fist. With current methods one operator is needed to open the victim's hand and one operator is needed to cut the fingernail while simultaneously holding the nail sample with tweezers. A specialized forensic nail collector should allow to cut fingernails from a clenched fist with one hand while leaving the other hand free to open the fist of the victim. *This design criterion is satisfied as the offset and small cutting jaw make it relatively easy to cut nails from a clenched fist while the retainer secures the nail clippings.*
2. **Secure nail samples:** The forensic nail collector should have a fast, reliable and easy way to secure the cut nail samples. If the nail is secured in the nail cutter itself, it is less likely that the nail falls on the ground, potentially contaminating evidence (see design criterion 4). The container that stores the clipped nail samples should at least have enough storage space to store all ten fingernails from a victim. *This design criterion is satisfied by the box retainer around the cutting jaw securing the cut nail samples.*
3. **Minimize contamination risk:** The clipped nail samples and nail clipping device should not be at risk of getting contaminated by other sources. To reduce the contamination risk, the forensic nail collector should be able to cut fingernails of different fingers, hands or victim's with a clean cutting jaw and storage container combination. The nail cutter should be cleanable and sterilizable or a disposable tool (one-time use).
4. **Maximize suspect-victim material ratio:** For DNA analysis it is important that the nail samples contain a maximum amount of suspect material and a minimum amount of victim material [21]. The tool should thus not damage the victim's skin, as any accidentally included victim cells like skin, blood, sweat etc. will increase the amount of victim DNA on the nail sample. *This design criterion is satisfied. Methods found to increase the suspect-victim material ratio found in literature do not allow the forensic nail collector to cut deep enough under the fingernail [8, 20].*
5. **Intuitive to use and learn:** Police officers and forensic workers are trained to cut nails. To reduce training time, increase the ease of use and lower the sensitivity to errors, the forensic nail collector should be intuitive to use.
6. **Durability:** The forensic nail collector should be reusable for multiple years of cutting all types of human nails. Field use at crime scenes requires a well-made and sturdy forensic nail collector. The forensic nail collector should be resistant to cleaning and sterilization to prevent contamination between cases [7, 23]. When disposable parts are used they should be durable enough to function at least the duration of one crime scene.

### 1.2.2. New design criteria

The concepts described in the upcoming Sections 1.3.1 and 1.3.2 must satisfy all design criteria listed above in Section 1.2.1. Design criteria 1, 2 and 4 described above in Section 1.2.1 are already satisfied with the forensic nail collector design shown in Figure 1.2. Design criteria 3 and 5 from Section 1.2.1 above are rephrased in 'sterilizability' and 'ease of (dis)assembly' to formulate these design criteria more specific. Rotational stiffness, spring quality and production cost are added as new design criteria to meet the redesign goals described in Section 1.1.4 (Refrain top cutting tooth from rotating, replacement of the coil spring and manufacturability).

The new design criteria are described below:

1. **Rotational stiffness:** The top cutting tooth should be refrained from rotating compared to the bottom cutting tooth. Due to material stiffness and play between each forensic nail collector part, some rotation will always be possible. A high rotational stiffness and little play between parts is required, to refrain the top cutting tooth from rotating, to make sure both cutting teeth cut exactly parallel on top of each other.
2. **Spring quality:** The spring should be able to deliver enough force to open the cutting jaw and handle part for the forensic nail collector to function properly. When the spring is too stiff, an unnecessary high handle force is needed to close the cutting jaw.
3. **Sterilizability:** During a forensic case the forensic nail collector collects evidence from that specific case. To reduce the contamination risk between various forensic cases, the forensic nail collector must be cleaned and sterilized between these forensic cases. Avoiding tight spaces and sharp corners improves the cleanability and sterilizability of the forensic nail collector.
4. **Ease of (dis)assembly:** To clean and sterilize the forensic nail collector thoroughly it is important that all parts can be disassembled, as sources of contamination can be collected between the

various parts of the forensic nail collector. An easy to (dis)assemble forensic nail collector allows the forensic nail collector to be cleaned and sterilized faster and easier. At a crime scene it should also be possible to swap cutting heads of the forensic nail collector fast to allow cutting of each fingernail with a clean and sterile cutting head.

5. **Durability:** Same as Criterion 6 described above in Section 1.2.1.
6. **Production cost:** The production and material costs are the two factors that determine the cost price of the forensic nail collector. Low production and material costs are preferred.

### 1.3. Concepts: Designing an improved and easier to manufacture forensic nail collector

#### 1.3.1. Concepts: Preventing the top jaw from rotating

Six concepts aimed at preventing the top cutting tooth of the forensic nail collector from rotating compared to the lower cutting tooth are provided in Figure 1.5. Preventing the top cutting tooth of the forensic nail collector from rotating compared to the bottom cutting tooth is important to reduce the cutting force required to cut nails. Advantages and disadvantages of each concept are explained in the figure.

#### Production costs and manufacturability

Production costs are one of the design criteria discussed in Section 1.2.2. It is hard to predict how much each concept is going to cost exactly, as these cost differentiate between various manufacturers and are dependent on the production quantity. The difficulty to manufacture a part is in this report determined as the number of manufacturing steps times the difficulty of each manufacturing step. The difficulty of a manufacturing step is rated as relatively easy or relatively difficult. A concept specific explanation for the difficulty of each manufacturing step is given in Figure 1.5 and 1.6. The difficulty of most drilling, welding and (rotary) milling manufacturing steps is rated as easy. Slow manufacturing steps are rated as relatively difficult, for example when a high milling depth to tool diameter is necessary.

#### 1.3.2. Concepts: Removal of the coil spring

Six concepts aimed at removing the coil spring from the cutting jaw are provided in Figure 1.6. Removing the coil spring from the cutting jaw of the forensic nail collector is important as the coil spring is difficult to clean and sterilize and nails samples get stuck between the coils of the spring and the shaft connected to the lower cutting tooth. Advantages and disadvantages of each concept are explained in the figure.

#### Injection molding

Multiple spring removal concepts replace the coil spring by a spring element inside the box retainer. An injection molded disposable plastic box retainer is likely the cheapest method to manufacture the high quantity of box retainers necessary. However, the injection molding manufacturing process restricts potential box retainer designs. Three important design restrictions of injection molding are shortly explained below:

- **Uniform (minimum) wall thickness:** Injection molded parts need a consistent wall thickness. Otherwise the molded part can potentially warp or become distorted. Depending on the type of plastic there is a minimum wall thickness, as the molten plastic is otherwise not able to flow through the mold.
- **Drafted parts:** A small draft (of  $0.5^\circ$  or more) on walls allows easier ejection of the part from the mold without drag marks on the walls of the part.
- **Avoid undercuts:** An undercut is an area of the injection molded part that shadows another area that part. Due to the undercut the the molded part is not able to be released from one of the mold halves as is shown in Figure 1.4.

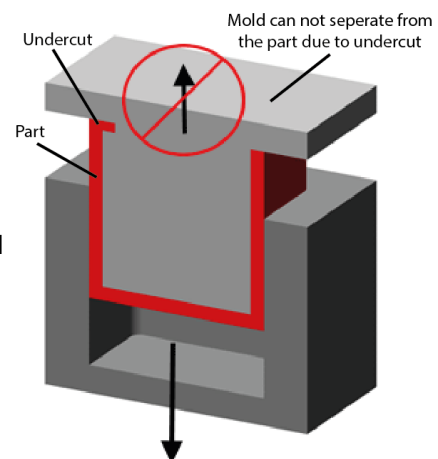

Figure 1.4: The two mold halves are not able to separate due to an undercut [9].

<p><b>1: Keyed shaft</b></p>  <p>Keyway Key</p> <p>A keyway is machined in the inner shaft and a small key in the outer shaft prevents the outer shaft from rotating</p> <ul style="list-style-type: none"> <li>- Difficult to clean and sterilize as the key and keyway produce lots of sharp angles and difficult to reach places</li> <li>- Keyway weakens inner shaft</li> <li>+ 3 relative easy extra manufacturing steps: mill the keyway, drill a hole in the outer shaft and weld a small pin the drilled hole in the outer shaft</li> </ul>	<p><b>2: Stronger box</b></p>  <p>Square shaft and retainer are designed to prevent rotation like a wrench-nut combination</p> <ul style="list-style-type: none"> <li>+ Disposable --&gt; no sterilization necessary</li> <li>+ Cheap to produce as the box must already be made, no extra manufacturing steps</li> <li>- Stiffer box requires thicker box walls --&gt; This increases the size of the cutting jaw, making the cutting jaw less manouverable in tight spaces like a clenched fist</li> </ul>
<p><b>3: Single component cutting jaw</b></p>  <p>Cutting teeth</p> <p>The top and bottom cutting teeth are connected by an arc that functions as a spring and prevents rotation</p> <ul style="list-style-type: none"> <li>+ Prevents both rotation and functions as a spring</li> <li>+ Easy to produce in large quantities with the right dye</li> <li>- Potential fatigue at U-shaped spring</li> <li>- Complex to produce as a prototype: The 3 bends necessary (cutting teeth 2x and arc) are relative difficult to manufacture as a prototype (see Section 1.5)</li> <li>Easy to produce in large quantities with a relative expensive dye</li> </ul>	<p><b>4: Rotation prevention in handle connection</b></p>  <p>A small upright support fits tight in the front opening slit of the bottom handle, preventing the outer shaft from rotating</p> <ul style="list-style-type: none"> <li>+ Easy to manufacture: 1 extra relative easy milling step on the top of the outer shaft</li> </ul>
<p><b>5: Square shafts (or splined shafts)</b></p>  <p>A square shaft combined with a square hole in the outer shaft prevent the top cutting teeth from rotating</p> <ul style="list-style-type: none"> <li>- 1 difficult extra manufacturing step: Manufacturing a square hole in the outer shaft or top cutting tooth is impossible to drill. A small mill would be necessary do mill a square hole. A small mill requires a slow milling speed.</li> <li>- Matching splined shafts are expensive to buy</li> <li>- Square or splined hole in outer shaft is difficult to sterilize as sharp angles produce tight spaces</li> </ul>	<p><b>6: Double connected cutting teeth</b></p>  <p>The top and bottom cutting teeth are connected by the inner and outer shaft. Atleast one upright support in the bottom cutting tooth and matching hole in the top cutting tooth prevent rotation</p> <ul style="list-style-type: none"> <li>+ 3 easy extra manufacturing steps: Drilling an extra hole in both cutting teeth, an extra welding step to fixate the small support in the bottom cutting teeth</li> <li>- Upright supports may prevent cutting of long fingernails as the upright supports are close to the cutting teeth</li> </ul>

Figure 1.5: Six concepts aimed at preventing the top cutting tooth of the forensic nail collector from rotating relative to the bottom cutting tooth.

<p><b>1: One component cutting jaw</b> Exact same as concept 3 of Figure 1.5.</p>  <p>Cutting teeth</p> <p>The top and bottom cutting teeth are connected by an arc that functions as a spring and prevents rotation</p> <ul style="list-style-type: none"> <li>+ Prevents both rotation and functions as a spring</li> <li>+ Easy to produce in large quantities with the right dye</li> <li>- Potential fatigue at U-shaped spring</li> <li>- Complex to produce as a prototype: The 3 bends necessary (2x cutting teeth and arc) are relative difficult to manufacture as a prototype (see Section 1.5). However, easy to produce in large quantities with a relative expensive dye.</li> </ul>	<p><b>2: Leaf spring retainer</b></p>  <p>Leaf spring molded in a plastic retainer</p> <ul style="list-style-type: none"> <li>+ Disposable --&gt; no sterilization necessary</li> <li>- Uncertain if the plastic spring is durable enough and is able to deliver enough force to open the cutting jaw. Durability and spring force is further evaluated in upcoming Section 1.7.</li> <li>- Difficult to injection mold due to undercuts created by the leaf springs. In section 1.7 a redesigned leaf spring retainer is shown that is injection moldable.</li> </ul>
<p><b>3: Back-wall leaf spring</b></p>  <p>The back wall of the retainer is flexible functioning as a spring</p> <ul style="list-style-type: none"> <li>+ Disposable</li> <li>+ Easy to injection mold</li> <li>- Uncertain if the plastic spring is durable enough and is able to deliver enough force to open the cutting jaw.</li> <li>- Inner shaft needs to be placed forward close to the cutting teeth. The inner shaft may restrict very long fingernails to be inserted deep enough in the cutting jaw to be cut in a single piece.</li> </ul>	<p><b>4: S-spring retainer</b></p>  <p>S-spring</p> <p>Snap-fits to close back wall</p> <p>Closable back wall</p> <ul style="list-style-type: none"> <li>+ Disposable</li> <li>- Uncertain if the plastic spring is durable enough and is able to deliver enough force to open the cutting jaw.</li> </ul>
<p><b>5: Compressible material retainer</b></p>  <p>Compressible (rubber) material functioning as a spring</p> <ul style="list-style-type: none"> <li>+ Disposable</li> <li>- Uncertain if spring strength is sufficient</li> <li>- Extra relative simple production step necessary to combine the plastic box with the compressible material compared to a plastic spring molded in the box.</li> </ul>	<p><b>6: Leaf spring</b></p>  <p>Slot to guide leaf spring</p> <p>Leaf spring</p> <p>Difficult to sterilize area</p> <p>Welded together</p> <ul style="list-style-type: none"> <li>+ Durability</li> <li>+ Can prevent rotation of the top jaw, if the leaf spring is rotationally stiff enough</li> <li>- Difficult to sterilize area due to sharp angles between the leaf spring and bottom cutting jaw</li> <li>- Welding the leaf spring is an extra relative simple production step compared to a plastic spring molded in the box. Two extra slots need to be milled in the top cutting tooth (2 relatively easy manufacturing steps).</li> </ul>

Figure 1.6: Six concept aimed at replacing the spring in the cutting jaw of the forensic nail collector seen in Figure 1.2.

## 1.4. Weighted objectives table: Best cutting jaw concept

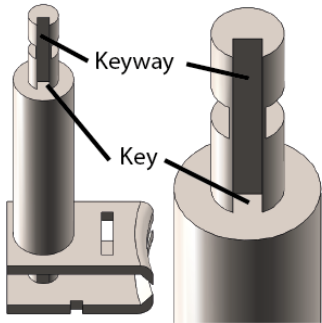
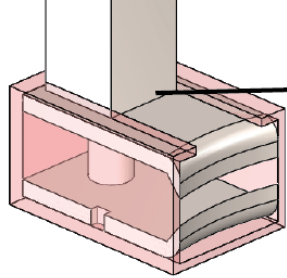
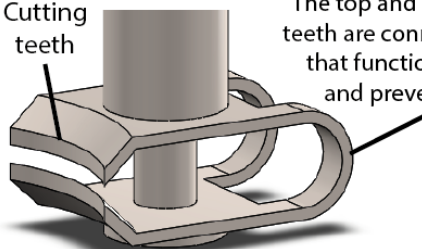
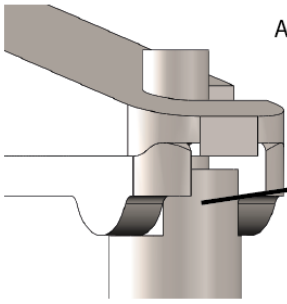
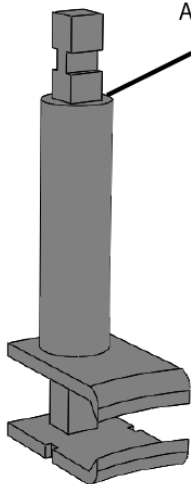
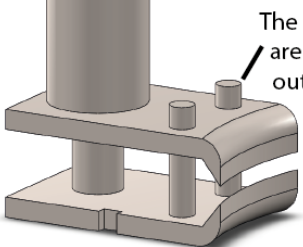
The six concepts from Section 1.3.1 that prevent the top cutting jaw from rotating were rated with a score between 1 and 5 against the concept test criteria from Section 1.2.2 in a Weighted Objectives Table (WOT) [6]. The concept test criteria from Section 1.2.2 were assigned a weighing factor between 1 and 3 based on their importance. Rotational stiffness (in Table 1.1), spring quality (in Table 1.2) and sterilizability are crucial design criteria for a functioning forensic nail collector and were thus given the highest weight factor of 3. Ease of (dis)assembly has a slightly lower weight factor of 2, as it is important forensic experts are able to swap cutting heads relatively fast at a crime scene. Durability also has a weight factor 2 as the forensic nail collector must have a sturdy feel and the reusable components should function for multiple years. Production costs of the production version of the forensic nail collector and its prototypes should not be disregarded during the design phase and were given a weight factor 1 in WOT table 1.1 and 1.2. The total score for each concept is the sum of all scores times their respective weight factor. The WOT table for the rotation prevention concepts is shown in Table 1.1 and the WOT table for the best spring removal concept is shown in Table 1.2.

Weight factor:	3	3	2	2	1	Total
	Rotational stiffness	Sterilizability	Ease of (dis)assembly	Durability	Production cost	
1. Keyed shaft	4	2	4	3	4	36
2. Stronger box	1	5	5	2	5	37
3. Single component cutting jaw	4	4	4	4	2	42
4. Rotation prevention in handle connection	4	4	4	4	4	44
5. Square shafts	5	1	4	5	2	38
6. Double connected cutting teeth	4	4	4	4	4	44

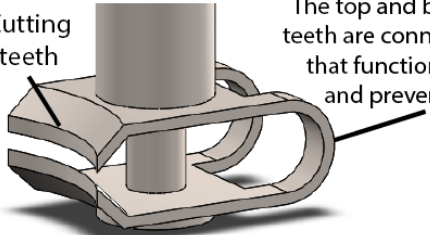
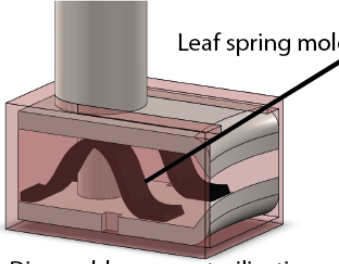
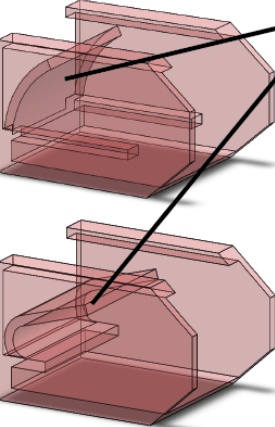
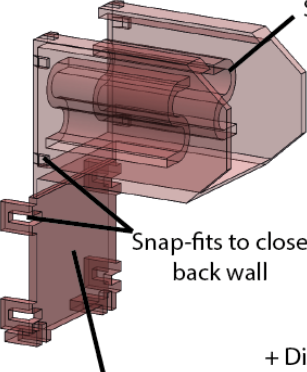
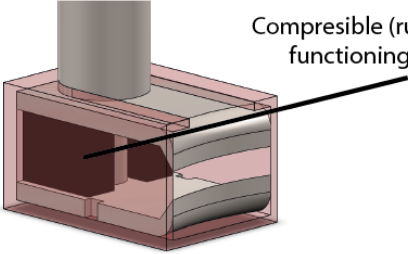
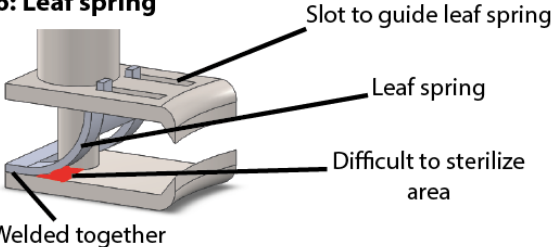
Table 1.1: Weighted Objective Table rating all six rotation prevention concepts from Section 1.3.1.

Weight factor:	3	3	2	2	1	Total
	Spring quality	Sterilizability	Ease of (dis)assembly	Durability	Production cost	
1. Single component cutting jaw	5	4	4	4	2	45
2. Leaf spring retainer	3	5	3	3	4	40
3. Back-wall leaf spring	3	5	3	3	4	40
4. S-spring retainer	3	5	3	1	4	36
5. Compressible material retainer	2	5	3	4	3	38
6. Leaf spring	5	2	4	4	3	40

Table 1.2: Weighted Objective Table rating all six spring removal concepts from Section 1.3.2.

## 1.5. Conceptualization: Single component cutting jaw

The single component cutting jaw is the highest scoring spring removal concept from Table 1.2 and second highest scoring rotation prevention concept from Table 1.1 only being outscored by the rotation prevention in handle connection concept and double connected cutting teeth concept. As the single component cutting jaw prevents rotation of the cutting teeth of the forensic nail collector and functions as a spring it seems to be the best concept to further delve into first.

### 1.5.1. AngleVue cutting jaw

The single component cutting jaw is based on the AngleVue (AngleVue, Korea) nail clipper, see Figure 1.7 [4, 14, 33]. The AngleVue cutting jaw from Figure 1.7 is made from stainless steel and has a length of 27.2 mm, a width of 11.1 mm and a plate thickness of 1 mm. The cutting jaw of the latest forensic nail collector shown in Figure 1.2 has a length of 22 mm and a width of 15 mm. If the cutting jaw of the forensic nail collector is too long, nail cutting in hard to reach places like a clenched fist becomes more difficult. A cheap option would be to buy the cutting jaw from Figure 1.7 and weld it to single of the forensic nail collector shafts. However, due to the decreased manoeuvrability of the longer AngleVue cutting jaw this is not ideal. A shorter



Figure 1.7: Cutting jaw of an AngleVue nail collector. The single component cutting jaw concept is based on this cutting jaw. This nail clipper was ordered from China and branded by TMISHION (TMISHION, China) [29].

version of the AngleVue cutting jaw that is more manoeuvrable in tight spaces like a clenched fist, seen in Figure 1.7 should be produced, as well as a box around it to store the nail clippings.

The single component cutting jaw concept seen in Figure 1.5 and 1.6 was improved, see Figure 1.8. One of the problems with concept version 1 seen in Figure 1.8 is that the hole in the bottom cutting tooth translates and changes angle slightly when the cutting teeth of the cutting jaw close. From experiments (see Chapter 2) and cutting the authors own fingernails, resulted that the high cutting teeth height of concept version 1 shown in Figure 1.8 makes it difficult to cut deep under the fingernail. Concept version 2 of Figure 1.8 has a lower cutting teeth height due to the angled bottom cutting tooth. A downside of concept version 2 shown in Figure 1.9 is that nail clippings will accumulate close to the cutting teeth opening when a box is placed around the single component cutting jaw to collect the nail samples. It is easier for the nail samples to drop out of the box around the cutting jaw as the nails are stored close to the opening between the cutting teeth.

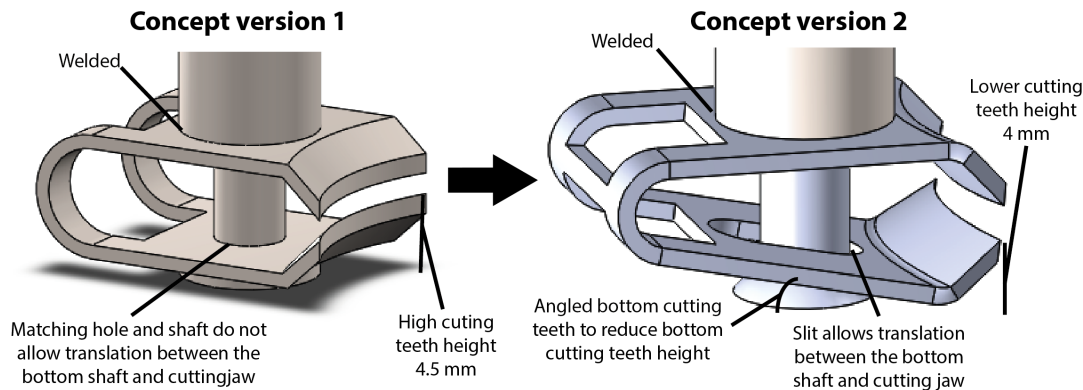

Figure 1.8: Concept version 2 is an improved version of concept version 1 shown in Figure 1.5 and 1.6.

### 1.5.2. Prototype production

Most nail clipper teeth from "normal" nail clippers (see Figure 1.1) are produced by bending sheet metal with the help of a dye in the right shape [11, 16]. With the same method a piece of sheet metal could be formed to the same shape as in Figure 1.9. With cutting teeth on either side of the piece of sheet metal, the piece of sheet metal is folded again in the middle so both cutting teeth can cut parallel on top of each other.

With the right dye it is cheap to produce a single component cutting jaw in large quantities as the nail clipper jaw shown in Figure 1.7 costed €0.97 [29]. However, producing a dye for a single prototype is time consuming. In consultation with DEMO (Electronic and Mechanical Support Division at TU delft) [27], potential manufacturing options were devised for producing a functioning prototype of the single component cutting jaw. The largest difficulty in producing one component cutting jaw prototype is producing the rounded cutting teeth needed to cut fingernails in a smooth arc. Three potential manufacturing methods for producing the single component cutting jaw concept were devised in consultation with DEMO:

1. **Milling the holes shown Figure 1.9 from a piece of sheet metal. Then bend the required cutting teeth without a dye by hand.** The small teeth seen in Figure 1.9 are most difficult to bend by hand. According to DEMO it is hard to predict how many test bends and thus how much time is necessary to manufacture a functioning single component cutting jaw prototype by bending the prototype by hand.
2. **Stainless steel 3D print of the one component cutting jaw.** This is the easiest method of producing a one component cutting jaw prototype. However, a 3D printed metal part has different material properties as the same part bent from sheet metal due to a different atom structure that is created when 3D printing the part. Although a 3D printed one component cutting jaw prototype would look similar, it would not function similar as the final product produced by bending the cutting jaw from sheet metal. As a result of different production methods, it is hard to predict how much the 3D printed one component cutting jaw part would have a different spring stiffness than a bent one component cutting jaw from sheet metal.

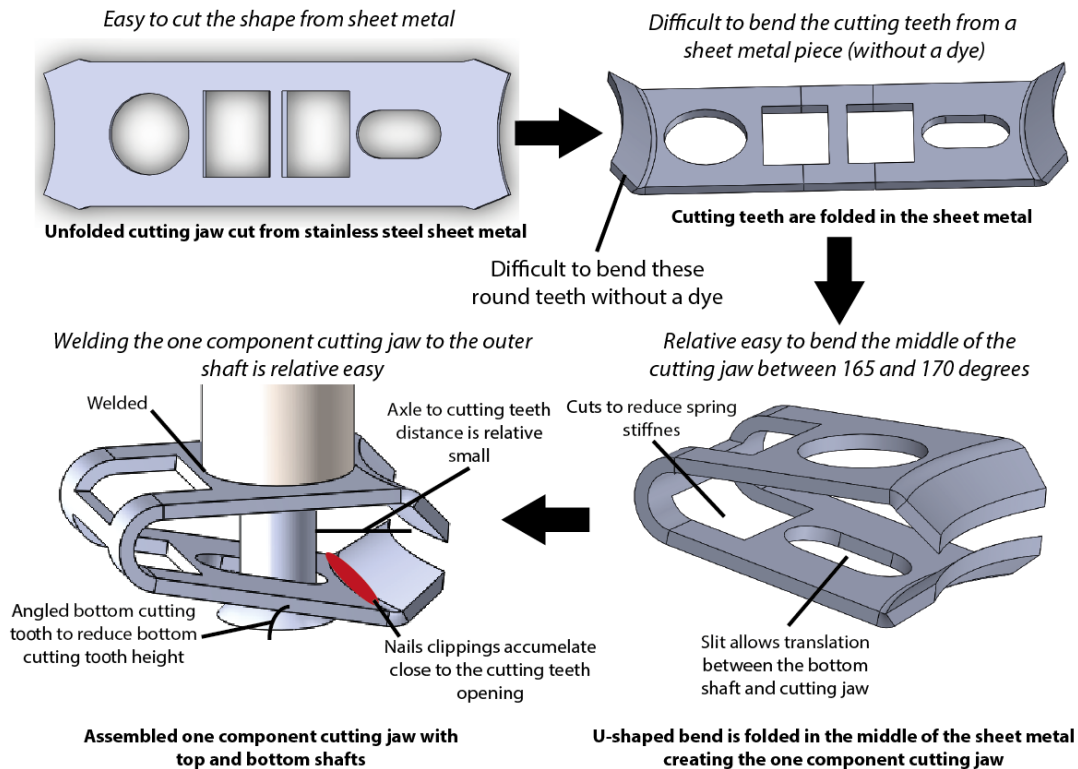

Figure 1.9: Solidworks illustration of the single component cutting jaw. The arrows show the bending process starting from a piece of stainless steel sheet metal.

- 3. Milling a one component cutting jaw from a stainless steel block.** Similar to manufacturing the one component cutting jaw with a 3D printer the material properties of a milled part are different than a part bent from sheet metal. The milling process 'destroys' atoms when cutting away material while bending the part results in stretched atoms and thus different characteristics. As a result of different production methods, it is hard to predict how much the milled single component cutting jaw part would have a different spring stiffness than a bent single component cutting jaw from sheet metal.

### 1.5.3. Rejection of the single-component cutting jaw concept

The single component cutting jaw is relative cheap to manufacture in high production quantities. However, prototype production of the single component cutting jaw is complex. It is either hard to predict the production time necessary (Method 1 from Section 1.5.2) or it is hard to predict how the material properties of the prototype resemble a mass produced single component cutting jaw that is bent from sheet metal. Depending on the design of the single component cutting jaw it may also be easier for the nails to fall out of the box retainer more easily as is seen in Figure 1.9. The single component cutting jaw concept is rejected as the concept is a lot less appealing than initially expected in Section 1.4. In hindsight, production cost should have had a higher weight factor or production cost of the prototype and production cost of the mass produced forensic nail collector should have been separate design criteria in the WOT tables shown in Section 1.4 for a more accurate score of the single component cutting jaw concept. In upcoming Sections 1.6 and 1.7 other concepts that prevent the top cutting tooth from rotating and removal of the coil spring are further developed.

## 1.6. Conceptualization: Rotation prevention in handle connection

The 'rotation prevention in handle connection' concept prevents the top cutting tooth from rotating by locking the outer shaft of the cutting head in the bottom handle similar to a wrench and a nut (see Figure 1.10). The 'rotation prevention in handle connection' concept is easy to manufacture with one relative simple milling operation at the top of the outer shaft. Concept version 1 in Figure 1.10, shows

the the same concept of the improved handle connection concept seen in Concept 4 of Figure 1.5. For this concept to work a new bottom handle with a wider slot would be necessary, see Figure 1.10. The outer shaft shown in concept version 2 of Figure 1.10, has the same functionality as concept version 1 shown in Figure 1.10. However, concept version 2 of the improved handle connection shown in Figure 1.10 lowers prototyping costs as it functions with the bottom handle of the existing prototype shown in Figure 1.2.

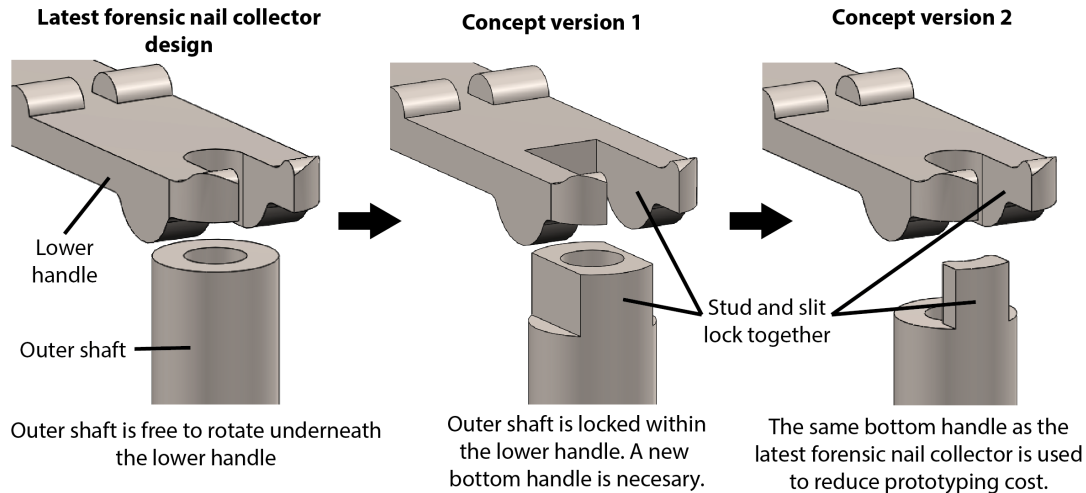

Figure 1.10: Exploded views of the bottom handle and outer shaft. The outer shaft of the latest forensic nail collector is able to rotate under the lower handle. Concept version 1 and 2 lock the outer shaft in the bottom handle similar to a wrench and a nut.

## 1.7. Conceptualization: Leaf spring retainer

The two highest scoring concepts from Table 1.2 that combine a spring mechanism with the box retainer were the leaf spring retainer and the back-wall leaf spring. The inner shaft of the forensic nail collector must be placed further forward, close to the cutting teeth using the back-wall leaf spring concept, potentially restricting the cutting of long fingernails. In this section is described how the leaf spring retainer concept shown in Figure 1.6 was further developed.

There are two potential problems with the leaf spring retainer concept design shown in Figure 1.6. First of all the leaf spring retainer shown in Figure 1.6 can not be injection molded due to undercuts caused by the leaf springs inside the retainer. The second problem is that it is uncertain if the two leaf springs in the retainer will break when fully compressed and if the leaf springs are able to deliver enough force to open the cutting jaw after each cut and keep the forensic nail collector assembled.

### 1.7.1. Injection moldable leaf spring retainer

The bottom wall of the retainer is used to circumvent the undercuts created by the two springs in the leaf spring retainer concept shown at Point 1 in Figure 1.15. The bottom wall of the leaf spring retainer is not necessary to be fully closed as the bottom cutting tooth of the forensic nail collector will close the bottom of the retainer, see Point 1 in Figure 1.15. The leaf spring retainer design shown in Point 2 of Figure 1.15 has an opened bottom wall. This opened bottom wall allows the leaf springs in the retainer to be molded at the parting line (see Figure 1.11) between the two mold halves at the top and bottom of the retainer [25]. Draft was added to the inside and outside walls of the retainer to allow easier ejection of the part from the mould. A Protolabs Automated Design Analysis (Protolabs, Inc, Maple Pain, United States) showed that the leaf spring retainer shown in Figure 1.15 can be injection molded [24]. A screenshot of the Protolabs Automated Design Analysis is shown in Appendix C.

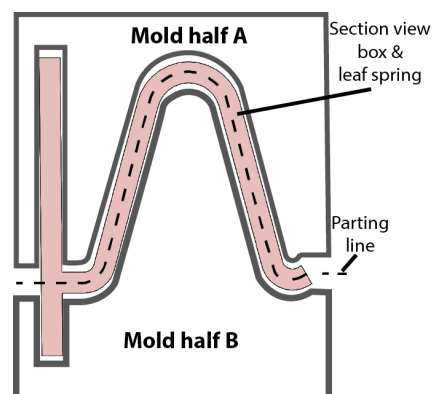

Figure 1.11: Section view of the leaf spring retainer. The leaf spring is molded at the parting line between mold half A and B.

### 1.7.2. Required spring force

Before designing a spring it is important to calculate the minimum required spring force necessary. In a static position the spring keeps the bottom handle and top cutting jaw in place. A schematic overview of the static forces on the bottom handle are shown in Figure 1.12 and Equations 1.1 till 1.6. The spring stiffness must be higher than the 3.2 N calculated in Equation 1.6 as frictional force between the inner and outer shaft of the forensic nail collector must be surpassed to open the cutting teeth after each cut.

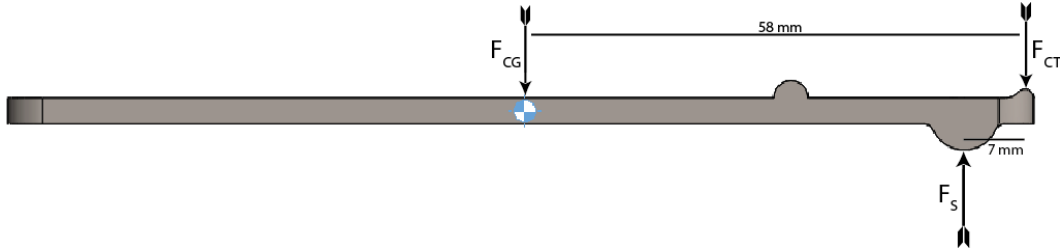

Figure 1.12: Schematic overview of the static forces on the bottom handle.  $F_s$  is the spring force,  $F_{CG}$  is the gravitational force on the bottom handle and  $F_{CT}$  is the contact force at the cutting teeth.

$$F_{spring\ total} = F_s + F_{TJ} \quad (1.1)$$

$$F_{TJ} = \text{Gravitational force of the top cutting jaw}$$

$$F_{TJ} = 21 * 10^{-3} kg * 9.81 = 0.2N \quad (1.2)$$

$$F_s * 7.0mm = F_{CG} * 58mm \quad (1.3)$$

$$F_s * 7.0mm = 37 * 10^{-3} kg * 9.81 * 58mm \quad (1.4)$$

$$F_s = 3.0N \quad (1.5)$$

$$F_{spring\ total} = 3.007 + 0.206 = 3.2N \quad (1.6)$$

The spring stiffness of the spring used in the forensic nail collector shown in Figure 1.2 is unknown. However it is possible to estimate the spring stiffness by calculations. The coil spring inside the cutting jaw of the forensic nail collector shown in Figure 1.2 is 24 mm long, has an outer diameter of 7.6 mm, a wire diameter of 0.7 mm ( $d$ , see Figure 1.13) and 6.5 active coils ( $n$ ). The spring stiffness is calculated with Formula 1.7, with a shear modulus ( $G$ ) for steel spring wire of 79.3 GPa [34]. The calculated spring stiffness with Equation 1.7 is 1.1 N/mm. The spring deflection is 3.8 mm when the forensic nail collector has opened cutting teeth like in Figure 1.2. As a result the spring force is  $3.8 * 1.1 = 4.2N$ , higher than the static force necessary calculated in Equation 1.6.

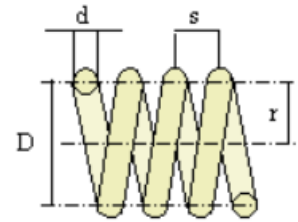

Figure 1.13: Spring dimensions visualized.

$$k = \frac{F}{f} = \frac{d^4 G}{64nr^3} \quad (1.7)$$

### 1.7.3. Spring stiffness analysis with Ansys

With Ansys Aim 19.0 (Ansys Inc, Canonsburg, United States) was tested if the plastic leaf springs of the leaf spring retainer concept would provide enough force to keep the forensic nail cutter assembled and if the plastic springs would not brake due to excessive stress. A single 3D spring was modeled with a width of 4 mm (the box of the forensic nail collector fits two of these springs). The spring is fixated and supported by the bottom cutting tooth, see Figure 1.14. The top cutting tooth moves downward, compressing the spring until the spring height is 5 mm, similar to the distance between the top and bottom cutting teeth of the forensic nail cutter when the cutting teeth are closed. The spring was meshed in cubes of 0.25 mm and the top and bottom cutting teeth were meshed in cubes of 0.5 mm. Multiple springs were simulated where the material, spring height, spring thickness, radius and spring angle were varied, see Table 1.3. Material properties of poly propylene copolymer (PPC), poly ethylene (PE) were used as these plastics are common and relatively flexible [28]. Acrylic (PMMA) was used to compare a simulated spring to a laser-cut leaf spring from a similar material.

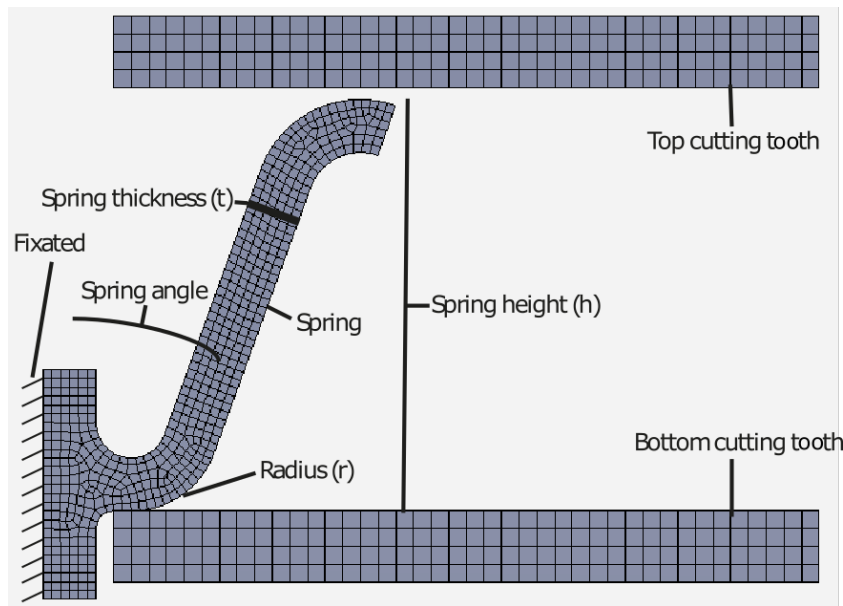

Figure 1.14: Schematic 2D view of the Ansys simulations performed.

Material	Young's modulus, E [Pa]	Poisson ratio, $\nu$	Yield Strength [Pa]	Tensile strength [Pa]	Reference
PPC	8.96e8	0.4103		2.76e7	Solidworks material library [10]
PMMA (acrylic)	3.0e9	0.35	4.5e7	7.3e7	Solidworks material library [10]
PE	1.1e9	0.42	2.5e7	3.3e7	Ansys material library [5]

Spring material	Spring height, h [mm]	Spring thickness, t [mm]	Spring radius, r [mm]	Spring angle [°]	Force at h=8.2mm	Max stress at h=5mm
PPC	11,65	1,5	2,5	20	16.9N	1.6e8 Pa
PPC	12	1,5	4	20	5.3N	1.2e8 Pa
PMMA	12	1,5	4	20	35.3N	3.8e8 Pa
PE	9,5	1,5	8	50	1.6N	5.0e7 Pa
PE	10	1	8	50	1.1N	3.3e7 Pa

Table 1.3: Material properties used during the Ansys simulations. Multiple leaf springs were simulated of which the results of five simulations are shown. The spring height, spring thickness, spring radius and spring angle are illustrated in Figure 1.14.

Table 1.3 shows the results from five Ansys simulations with varying leaf spring dimensions and materials. When the forensic nail collector is assembled the height between the top and bottom cutting teeth is 8.2 mm. When the leaf spring is compressed to 8.2 mm it must deliver at least  $3.2/2 = 1.6N$  to keep the forensic nail collector assembled as calculated in 1.6. When the forensic nail collector teeth are closed the leaf springs will be compressed to a height of 5 mm. When the leaf spring is compressed to a height of 5 mm the stresses should not exceed the tensile strength of the leaf spring material.

The maximum stress in the leaf spring when compressed to 5 mm of all simulations except the last simulation shown in Table 1.3 are above the tensile strength. The last simulation shown Table 1.3 only exerts a force of 1.1 newton (2.2 N with two leaf springs), much lower than the minimum force required of 3.2 N calculated with Equation 1.6. All plastic leaf springs simulated will either brake or plastically deform due to high stresses or are not able to deliver the minimum force required. Larger leaf springs are not an option as these would not fit inside the cutting jaw. Leaf springs with a spring thickness lower than 1 mm can not be manufactured with injection molding as 1 mm is close to the minimum injection mold wall thickness [24]. Screenshots from the meshed leaf springs and compressed leaf springs at 5 mm are shown in Appendix C.

### 1.7.4. Insert-molded leaf spring retainer alternative

Insert molding is an injection molding process where the plastic is molded around an pre-placed insert. Point 5 of Figure 1.15 shows an leaf spring retainer with a metal leaf spring insert molded in the back wall of the plastic retainer. According to a Protolabs Automated Design Analysis the insert mold design shown in Point 5 of Figure 1.15 is not manufacturable due to 'insufficient location' of the insert and because the insert is too thin and fragile for the insert mold process [24]. A screenshot of the Protolabs Automated Design Analysis is shown in Appendix C.

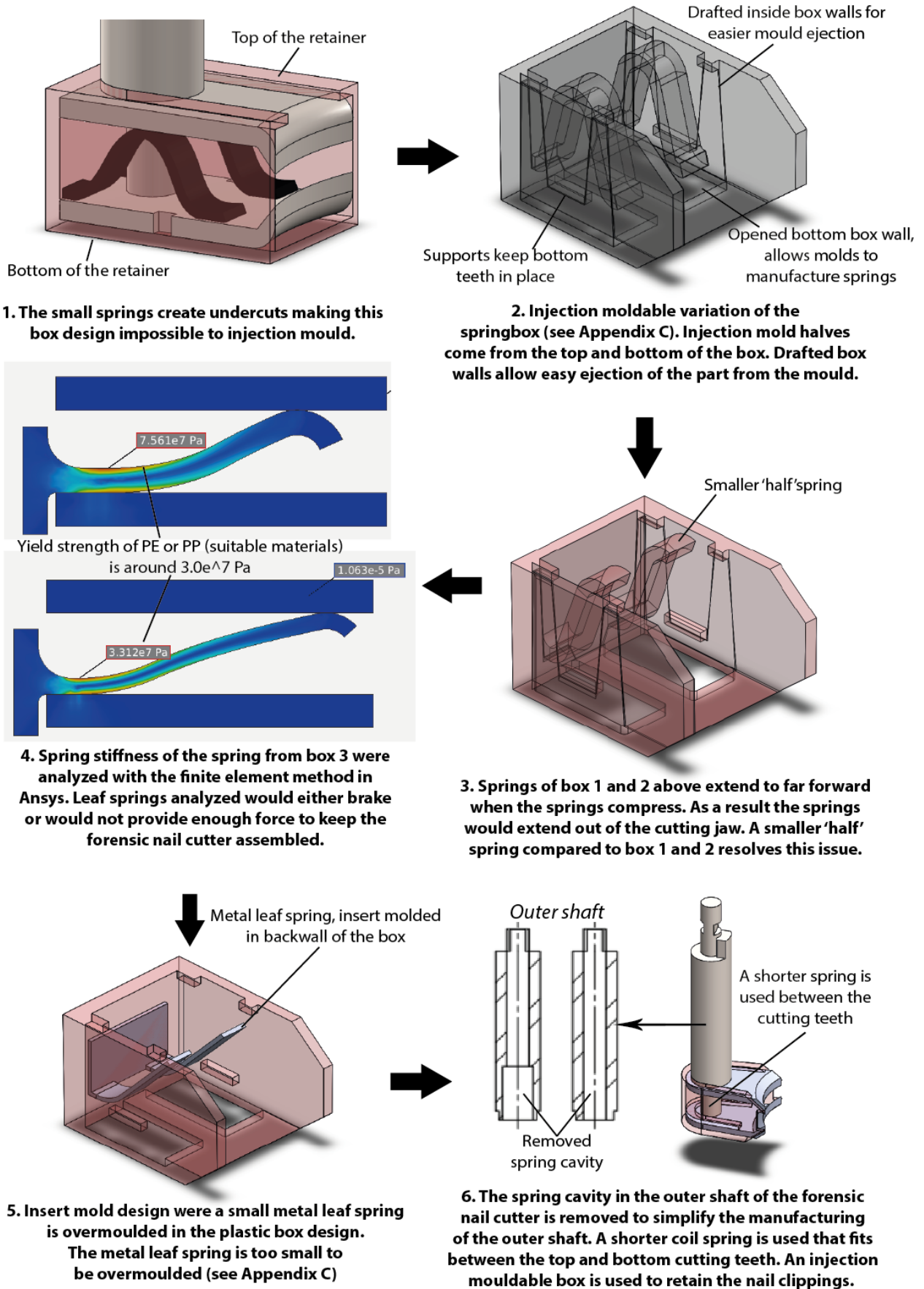

Figure 1.15: The leaf spring retainer at Point 1 is the concept concept from Figure 1.6. The design steps from the leaf spring retainer concept to the improved cutting jaw design at Point 6 is visualized.

### 1.7.5. Improving the manufacturability and usability of the cutting jaw

Unfortunately a feasible concept to remove the coil spring from the cutting jaw of the forensic nail collector was not found. However, from experiments (see Chapter 2) it is known that with the current cutting teeth it is difficult to cut deep enough under the nail and that it is difficult to cut nails in a single piece. The current cutting head of the forensic nail collector is also not optimized for manufacturability.

#### Improving the functionality of the cutting teeth

The radius of four normal nail clippers like the nail clipper shown in Figure 1.1 were measured with various round objects like coins and bottle caps. Most of these nail clipper have a cutting teeth diameter around 30 mm. The cutting teeth of the latest forensic nail collector are also 'steeper' than the cutting teeth of most normal nail clippers making it difficult to cut deep under the nail.

New cutting teeth were designed with a cutting teeth shape more similar to cutting teeth of normal nail clippers, see Figure 1.16. The cutting jaw shown in Figure 1.16 has a cutting teeth diameter of 30 mm and has a slacker cutting teeth angle of 45 degrees. The tapered cutting teeth also reduce the overall volume of the cutting jaw compared to the cutting jaw of the latest forensic nail collector shown in Figure 1.2 to make cutting in tight spaces like a clenched fist easier. Technical drawings of the redesigned cutting teeth are provided in Appendix C.

#### Improving the manufacturability of the cutting jaw

The manufacturability of the cutting jaw was improved by removing the 12 mm spring cavity from the outer shaft, see Figure 1.16. This 12 mm spring cavity was necessary as the current forensic nail cutter used a relatively long 24 mm spring. The spring cavity can be removed reducing the number of manufacturing steps to manufacture the outer shaft. A shorter compression spring is necessary that delivers enough force when the cutting teeth are compressed to 8.2 mm (height between cutting teeth when open) to keep the forensic nail cutter assembled and should have a length below 5 mm (height between cutting teeth when closed) when the spring is under maximum compression. The stainless steel compression spring with part number D21500 from Amatec (Amatec, Alphen aan den Rijn, Netherlands) has a spring stiffness of 1.52 N/mm and an uncompressed length of 11.5 mm [2]. The D21500 spring delivers  $(11.5 - 8.2) * 1.52 = 5N$ , slightly more than the spring in the current forensic nail collector and has length of 4.6 mm when fully compressed.

A few other changes to the cutting jaw design shown in Figure 1.16 make it easier to injection mold the retainer. The tapered cutting teeth add the necessary draft to the sidewalls of the retainer. The round back wall of the retainer shown in Figure 1.16 allows the molten material to flow better through the mold, compared to the 90° edges present on the current forensic nail collector retainer shown in Figure 1.2.

A prototype of the cutting jaw shown in Figure 1.16 is being produced. The technical drawing corresponding to this cutting jaw design are provided in Appendix C.

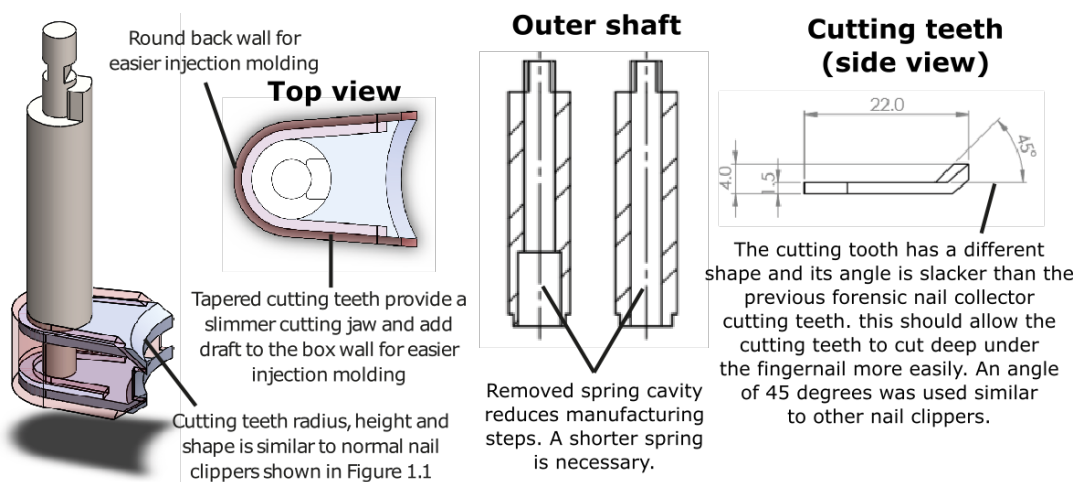

Figure 1.16: Cutting jaw of the forensic nail collector designed for better manufacturability and usability.

## 1.8. Improving the manufacturability of the handles

### 1.8.1. Production methods of the current forensic nail collector handles

Both the top and bottom handle of the current forensic nail collector shown in Figure 1.2 are produced with two production steps.

#### Wire-cut electric discharge machining

The first step of producing the top and bottom handle of the forensic nail collector was done by cutting the general outline of the handles with wire-cut electric discharge machining (EDM) from a 13 mm thick stainless steel plate, see Figure 1.17. Other machining options, like water-jet machining or milling could also be used to produce the general shape of the forensic nail collector handles.

After the wire-cut EDM process the lower jaw axle connection slits are still missing from the handle parts, the handle aligner still has a full width of 13 mm instead of 5 mm width, the fulcrum is not machined in the top and bottom handle, and all corner edges are still sharp.

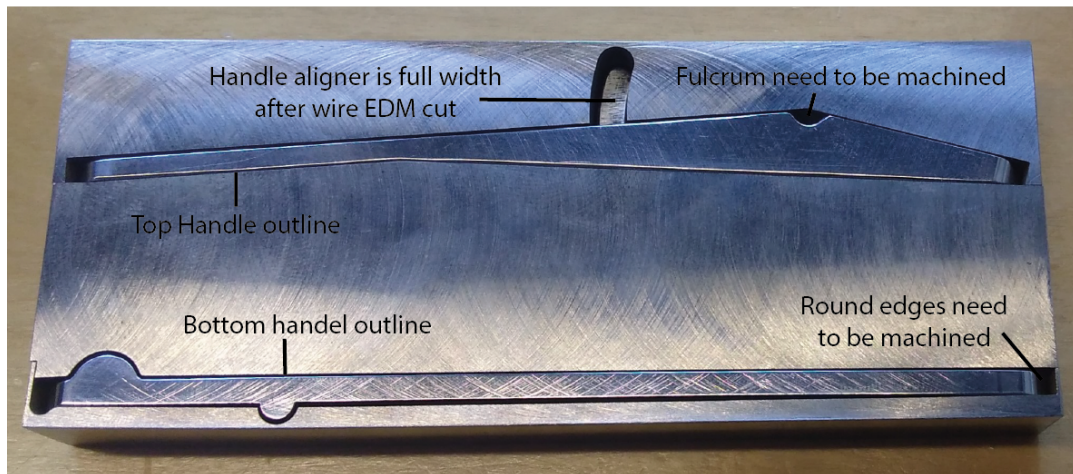

Figure 1.17: Wire-cut electric discharge machining cuts the general outline of the forensic nail collector handles from a 13 mm stainless steel plate. The forensic nail collector handles are then further machined to produce the functioning handles seen in figure 1.2.

#### Milling operations

Figure 1.18 shows the top and bottom handle of the latest forensic nail collector prototype and the milling operations necessary to manufacture the handles of the latest forensic nail collector shown in Figure 1.2. Each color (green, orange, purple and yellow) correspond with a different milling orientation. The handle part is reoriented each time a milling machine has to approach a different direction of the part. Each time the part is reoriented, the set-up time to produce the part is increased. Reducing the number of times the part needs to be reoriented during production reduces the production time and costs. The top handle is milled from four different orientations and the bottom handle from only one orientation. Milling from four different orientations requires a relatively high set-up time. The bottom handle part requires a relative low set-up time as only one milling orientation is necessary to produce the part.

As can be seen from Figure 1.18, the three stability elements add a lot of small milling operations to both forensic nail collector handles. According to the manufacturer from DEMO the handle aligner stability element is most difficult to manufacture [27].

### 1.8.2. Testing each stability element with 3D printed top handle prototypes

The handle aligner, slit in the fulcrum and connector teeth were tested with 3D printed top handles combined with the other stainless steel parts of the forensic nail collector. Three 3D printed top handles were used, each with one stability element remaining: one with only the handle aligner, one with only the fulcrum slit and one with only the connector teeth. A fourth 3D printed copy of the existing top handle was used for comparison. The handle kink was displaced for all 3D printed top handles, see

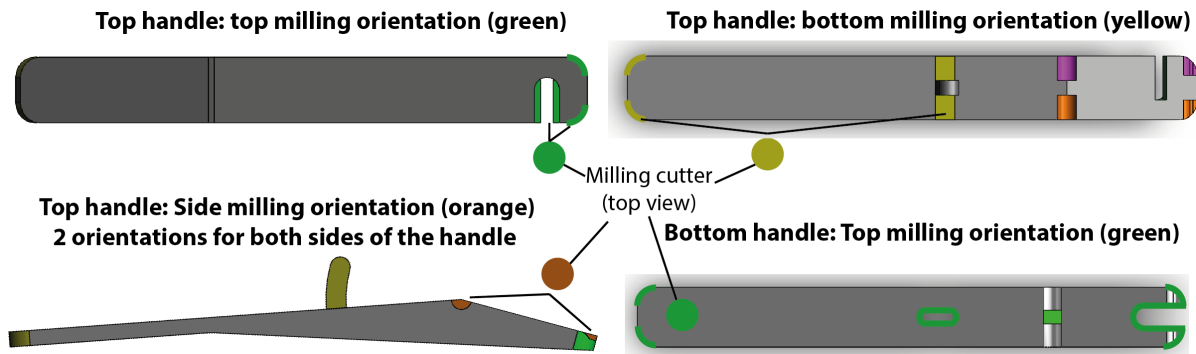

Figure 1.18: The top handle is shown in all 4 milling orientations and the bottom handle is shown in its single milling orientation. The circles represent a top view of the milling cutter. All milling operations are colored in green, orange, pink or yellow depending on the milling orientation.

Figure 1.19. The displacement of the handle kink allowed the lower jaw axle slot to be simplified. All top handles were printed from PLA filament with an Ultimaker 2 3D printer (Ultimaker B.V., Geldersmalen, Netherlands). During the tests the amount of play between the top and bottom handle of an assembled forensic nail collector was tested by trying to twist both handles apart.

The stability that each individual stability element provided with the other elements left out is described below:

- The Connector teeth alone provide very little stability to the forensic nail collector assembly. When nails are cut the handles of the forensic nail collector open where the connector teeth are located and as a result the connector teeth of the bottom handle no longer make contact with the top handle. As a result the connector teeth do not provide any stability to the forensic nail collector when nails are cut.
- The 3D printed top handle with only the fulcrum slit provides similar play between the top and bottom handle of the forensic nail collector as the original 3D printed top handle with all three stability elements. The fulcrum slit alone provides enough stability to the assembled forensic nail collector to function correctly. The handle aligner and connector teeth are unnecessary for the stability, make the handle design more complex and thus increase manufacturing costs so could be removed.
- The 3D printed top handle with only the handle aligner provides similar play between the top and bottom handle of the forensic nail collector as the original 3D printed top handle with all three stability elements. The handle aligner provides enough stability to the assembled forensic nail collector to function correctly. The connector slit and connector teeth are unnecessary for the stability and increase manufacturing costs by making the handles more complex. According to DEMO the handle aligner stability element is most difficult and costly to manufacture.

Conclusively, the fulcrum slit alone provides the required stability to the assembled forensic nail collector handles and is an easier to manufacture stability element than the handle aligner. The fulcrum is kept the same on the new forensic nail collector handles. The connector teeth and handle aligner are removed from the forensic nail collector handles as they are redundant.

### 1.8.3. Changes to the design of the handles

Multiple simplifications made to the top handle of the forensic nail collector are visible in Figure 1.19. All simplifications to the top handle of the forensic nail collector are further explained below:

1. **Simplified connector teeth:** The connector teeth of the top handle of the latest forensic nail collector seen left in Figure 1.18 are made by two milling operations with a support in the middle. This support is removed from the top handle. The new top handle of the forensic nail collector has one larger indentation across the full width of the top handle. This larger indentation can now be produced with the wire-cut EDM method that is used to cut the general outline of the forensic nail collector handles, so extra milling operations are no longer necessary. The matching connector teeth of the current bottom handle are not changed as these are already produced without extra milling operations after the wire-cut EDM manufacturing process. The handles of the forensic

nail collector would still function and be even simpler to manufacture with the connector teeth fully removed as shown in Figure 1.20. However, the simplification shown in Figure 1.20 was not made to reduce prototyping costs as a new bottom handle would be necessary.

2. **handle aligner removed:** The handle aligner is fully removed from the top handle of the current forensic nail collector handle seen left in Figure 1.18 as it is the most difficult to manufacture stability element of the current top handle [27]. As a result of the removed handle aligner from the top handle of the forensic nail collector, the handle aligner slot in the bottom handle can be removed as well.
3. **Displaced handle kink:** The small kink in the top handle seen in Figure 1.2 was displaced. The displaced handle kink allows the lower jaw axle slot to be simplified.
4. **Simplified lower jaw axle slot:** The lower jaw axle slot in the top handle seen left in Figure 1.18 exists of a 2.5 mm width slot and a 5 mm width slot. The 3D printed top handles showed that only the 2.5 mm slot is necessary to hold the inner shaft of the forensic nail collector firmly. The 5 mm lower jaw axle slot is removed from the top handle of the forensic nail collector, further reducing the milling operations necessary to manufacture the top handle.

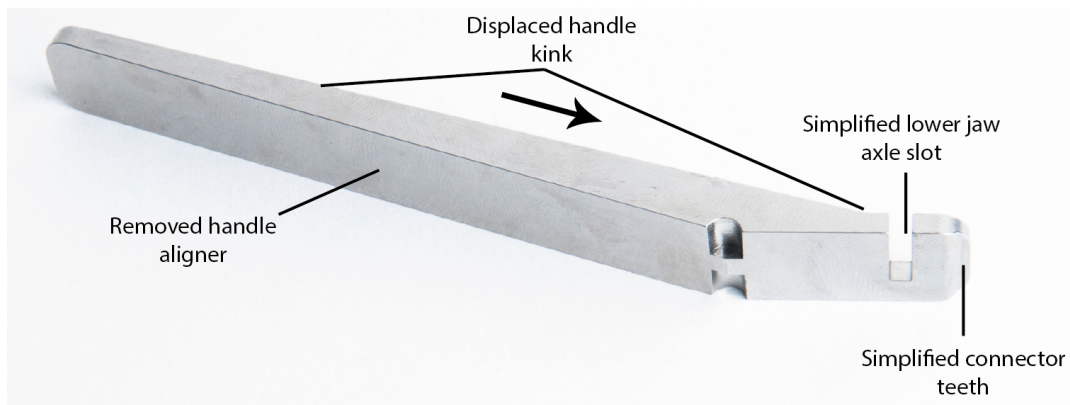

Figure 1.19: All changes and simplifications made to the top handle of the forensic nail collector are named.

The top handle of the forensic nail collector seen in Figure 1.19 was designed to be manufactured by first cutting the general outline of the handle with the wire-cut EDM method and then use milling operations to create the fulcrum, lower jaw axle slot and rounded edges. However, DEMO manufactured the top handle of the forensic nail collector seen in Figure 1.19 completely by milling the part.

## 1.9. Renewed forensic nail collector design

The renewed forensic nail collector is shown in Figure 1.21. In Chapter 2, the results are shown of a usability experiment with the renewed forensic nail collector shown in Figure 1.21. The technical drawings for all the parts of the forensic nail collector shown in Figure 1.21 are provided in Appendix B. A prototype of the cutting jaw shown in Figure 1.16 is currently being produced.

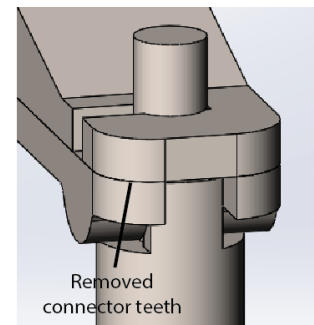

Figure 1.20: Connector teeth are fully removed from both the top and bottom handle.

## 1.10. Further recommendations

There are a few recommendations to further improve the renewed forensic nail collector shown in Figure 1.21:

1. **Prevent nails from falling out of the opening between the cutting teeth:** A solution that fully prevents nail samples from falling out of the box retainer was not found during this project. Reducing the height between the cutting teeth is not a solution as cutting large nails becomes more difficult or even impossible when the height between the cutting teeth becomes to small. A short experiment (see Appendix D) showed that the reduced height between the cutting teeth



Figure 1.21: Renewed forensic nail collector design. Changes made compared to the forensic nail collector shown in Figure 1.2 are named.

also does not fully prevent the nails from falling out of the box.

2. **Better leverage:** Multiple participants of the usability experiment (see Chapter 2) indicated that the hand force required to cut nails was high. The cutting force at the cutting teeth of a nail clipper was measured by a previous TU Delft project group between 22 and 38 N/mm of nail [18]. The cutting teeth of the forensic nail collector prototype are not very sharp and could be made from a harder type of stainless steel as the cutting teeth lose their sharpness quickly. Handles with better leverage can reduce the hand force needed to cut nails with the forensic nail collector even further.
3. **Remove coil spring:** Various concepts were worked out during this project with the aim to remove the coil spring from the forensic nail collector. During this project the goal of obtaining a working simplification that incorporates the spring with an already necessary part of the forensic nail collector was unfortunately not achieved. Concepts incorporating leaf springs with the box retainer or cutting teeth were either not manufacturable (Figure 1.15) or difficult to clean and sterilize (Concept 6 from Figure 1.6). Although not found during this project it may still be possible to incorporate a spring mechanism in another part of the forensic nail collector.
4. **Clear instructions:** There currently is a clear instruction video explaining how to (dis)assemble the forensic nail collector. The instructions can be further expanded with cutting and cleaning instructions.



# 2

## Research Paper: Testing the usability of a novel tool for forensic nail cutting

## Testing the usability of a novel tool for forensic nail collecting

Olaf Dessing and supervisor dr. ir. Arjo Loeve

**Abstract**— In forensic cases DNA and other trace evidence underneath the nails of victims can be crucial for finding and convicting the perpetrator. The victim’s nails are cut at the crime scene and sent to the lab for forensic analysis. Delft University of Technology has developed a forensic nail collector, to allow forensic experts to cut nails more easily, store cut nail clippings and prevent contamination of the cut nail samples. The first goal of the experiment was to find out if participants were able to (dis)assemble the forensic nail collector with no or limited experience. The second goal of the experiment was to find out if participants were able to cut nails faster and more easily from a hand clenching an object compared to a hand placed flat on the table. During the first part of the experiment the ease of (dis)assembly of the latest forensic nail collector prototype was tested, as (dis)assembling the forensic nail collector is potentially an unintuitive task to perform with no or little experience. 19 Participants disassembled and then reassembled the forensic nail collector ten times. All participants were asked how difficult it was to (dis)assemble the forensic nail collector through a questionnaire. Nine of the participants watched a (dis)assembly instruction video before the (dis)assembly experiment. During the second part of the experiment participants cut each others fingernails. One of the hands being cut was placed with the palm of the hand flat on the table and the other hand clenched a piece of pipe. A modified experiment was done with a forensic expert. A traditional forensic nail cutting method using scissors and tweezers was compared to nail cutting with the forensic nail collector. Participants that received instruction (dis)assembled the forensic nail collector faster and more consistent during the first tries. During later tries both the ‘instruction’ and ‘no instruction’ group were almost equally fast. At the end of the experiment all participants rated (dis)assembling the forensic nail collector relatively easy. With the forensic nail collector participants were faster and found it easier to cut the nails from the hand clenching a piece of pipe. The forensic expert was about 16% faster using the traditional forensic cutting method using scissors and tweezers. However, the forensic expert used the forensic nail collector for the first time. All participants and the forensic expert were asked to provide feedback to further improve the forensic nail collector. The high hand force necessary to cut nails with the forensic nail collector was the most heard feedback. Important feedback from the forensic expert was that it was difficult to cut deep under the fingernail. Feedback from the participants and forensic expert was used to redesign improved cutting teeth for the forensic nail collector.

### I. INTRODUCTION

#### A. Background

After crimes, important evidence may be left under the nails of a victim or suspect. Such evidence can consist of DNA, traces of paint or gunshot residues and may be crucial in finding or prosecuting a perpetrator [1]. Additionally nail clippings can be used for toxicologic analysis [2], [3], [4]. In order to collect as much of any traces under the nails as possible, the nails are swabbed [4] or scraped and then

clipped [5], [6], [7]. The nail scrapings and clippings are sent to a lab for forensic analysis [8], [5].

Nails are cut with simple nail scissors or nail clippers, see Figure 1. The nail sample is secured by tweezers when cut with nail scissors or caught on a piece of paper or caught in a glove when cut with nail clippers [5], [4]. These current methods for collecting nail samples are prone to errors as nails can easily fall on the ground contaminating potential evidence [6], [8].



Fig. 1. A simple nail clipper (left) and nail scissor (right) currently used as forensic nail cutting tools [9].

#### B. Introduction to the improved forensic nail collecting tool

The latest forensic nail collector prototype developed by Delft University of Technology is shown in Figure 2. The forensic nail collector is designed to safely cuts nails, stores clipped nail samples, is easy-to-use and prevents contamination of evidence [10]. At a crime scene fingernails of different fingers, hands or victim’s must be able to be cut with a clean cutting head to reduce the risk of contamination. The forensic nail collector is disassembled in the cutting head and both handles and then reassembled with a new clean cutting head between each fingernail, hand or victim. The (dis)assembly process must be easy and intuitive to do at a crime scene to speed-up the time between fingernails being cut. With some experience, (dis)assembling the forensic nail collector is easy and quickly to do within 2-5 seconds. However, (dis)assembling the forensic nail collector may be an unintuitive task to perform with no or little experience. The first goal of this experiment was to find out if participants were able to (dis)assemble the forensic nail collector with and without any instructions and if participants were able to become progressively faster over multiple (dis)assembly tries.

Due to rigor mortis deceased bodies turn stiff and may be found at a crime scene with clenched fists or hands clenching an object like a piece of pipe, gun or knife [11], [12]. Cutting

a clenched hand with traditional cutting methods using a nail scissor or nail clipper as seen in Figure 1 is often a task performed by two forensic operators. One forensic operator opens the finger, while the other forensic operator cuts and secures the fingernail sample. The forensic nail collector is designed to make the task of cutting nails from a clenched fist or a hand clenching an object easier. The second goal of this experiment was to test if participants were able to easily cut nails from a hand clenching an object. The third goal was to test if a forensic expert was able to cut nails faster and more easily with the forensic nail collector prototype than with traditional forensic cutting methods using a nail scissor and tweezers.

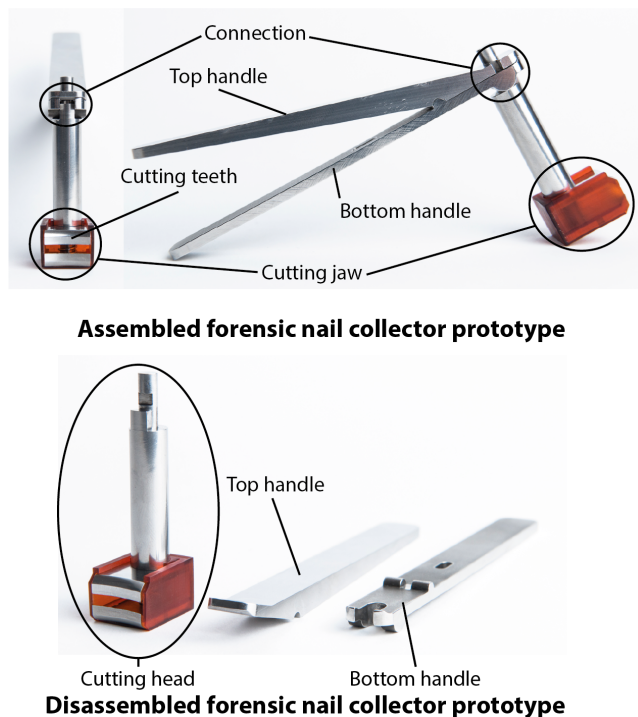

Fig. 2. **Top:** Assembled forensic nail collector. **Bottom:** The three pieces the forensic nail collector is disassembled in during the experiments.

## II. METHODS & MATERIALS

During the experiments, participants disassemble the forensic nail collector ten times in the top handle, bottom handle and cutting head (see in Figure 2) and then reassemble the forensic nail collector again. As a second part of the experiment participants cut the fingernails from another participants hands. The participants right hand was placed with the palm flat on the table, the left hand clenched a piece of pipe.

### A. Experiment setup and materials

The experimental setup used during the (dis)assembly and cutting experiment is shown in Figure 3. Two participants were placed at opposite sides of the table. The screen was used so participants were not able to watch the other participant (dis)assemble the forensic nail collector prototype or

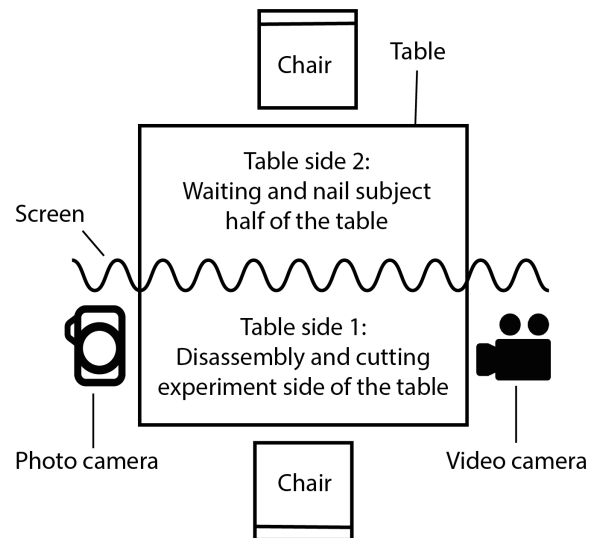

Fig. 3. Experiment setup used during both the (dis)assembly and cutting experiment. The table is split in two sides by a screen (black curtain). Camera's are used to photograph participants hands and film the (dis)assembly and cutting experiment.

their own hands during the cutting experiment. All materials used during the experiments are shown in Table I.

### B. Participant selection

In total 18 students and employees from Delft University of Technology and one forensic expert from the Netherlands Forensic Institute (NFI) were recruited for the experiments through verbal and poster advertisement. The research conducted was approved by the Human Research Ethics Committee of Delft University of Technology (approval number 446). All participants gave written informed consent. At the beginning of the experiment, participants were asked their gender, age and dominant hand, see Table II. All data was anonymously stored offline.

### C. Experiment protocol

The following steps below were taken in chronological order during the experiment:

1. Participants entered the experiment room in duos.
2. Participants were briefed about the experiment and were asked to sign the informed consent form.
3. Each participant was anonymously numbered during the experiment as X.Y, With X the number of the duo from 1 (first group) till 9 (last group) and Y the participant number within that duo, randomly assigned (1 or 2). Participant number was written down at question 1 of the Questionnaire Forensic Nail Collector form. A sign was made for each participant with his/her participant number. The sign was visible in all pictures and videos taken during the experiment with that participant.
4. Participants answered questions 2-4 of the Questionnaire Forensic Nail Collector form.
5. Hand size (length from wrist to longest fingertip) was measured with a ruler and free edge length of the

Material	Brand & type	Manufacturer location	Description	Amount
Forensic nail collector	-	-	-	1
Table	-	-	Circa 1x1.5 m	1
Chairs	-	-	-	2
Screen	-	-	Black Curtain	1
Tripod screen	FalconEyes Light Stand L5200H	Falcon Eyes Limited, Hong Kong	Span black curtain	2
Video camera	Panasonic HC-V25	Panasonic Corporation, Osaka, Japan	Filming at 720p	1
Photo camera	Nikon D610	Nikon Corporation, Tokyo, Japan	-	1
Photo camera lens	Nikon ASF Nikkor 42-70mm	Nikon Corporation, Tokyo, Japan	-	1
Tripod camera	Manfrotto 290	Lino Manfrotto + co. Spa, Cassola, Italy	For video and photo camera	2
Stopwatch	Genutec Electronics L0 CG-501	CatigaElectronics CO LTD, Hong Kong	-	1
TV screen	Sony KDL37W5500	Sony Corporation, Tokyo, Japan	Showing instruction video	1
PVC pipe	-	-	32 mm diameter, circa 25 cm long	1
Ruler	-	-	-	1
Caliper	-	-	Analog	1

TABLE I

MATERIALS USED DURING THE (DIS)ASSEMBLY AND CUTTING EXPERIMENT EXPERIMENTS

middle fingernail was measured with a caliper and photographed [13]. Measurements and file number of the photo were written down at question 5-7 of the Questionnaire Forensic Nail Collector form.

6. All even group numbers (X) watched an instruction video. Uneven group numbers did only receive general instructions about the experiment, seen in Appendix A.
7. Participant X.1 took place at Table side 1 (see Figure 3) and was asked to dis- and reassemble the forensic nail collector 10 times. Each try the dis- and reassemble times were measured with a stopwatch. When the investigators said START the time was started. The time was stopped when the participant finished disassembling the forensic nail collector prototype and said STOP. The investigator said START to start the time again. The time was stopped when the participant finished assembling the forensic nail collector prototype and said STOP. The hands of the participant were filmed during the (dis)assembly experiment. The video file number was written down together with the (dis)assemble times on the Questionnaire Forensic Nail Collector form at question 9 and 10. Participant X.2 sat behind the screen at table side 2 (see Figure 3) and was thus not able to see the (dis)assembly techniques of participant X.1.
8. Participant X.1 and X.2 swapped places and roles and step 7 was repeated.
9. Participant X.2 sat at table side 2 (see Figure 3) and held his/her right hand with the palm flat on the table behind a screen on table side 1 so the participant could not see his/her own hands and held the PVC pipe firmly with a clenched fist in the left hand with the back of the hand on the table behind the screen on table side 1. Participant X.2 was instructed to keep the fingers firmly clenched around the pipe even if participant X.1 tried to open them as the forensic nail collector is designed to cut nails from a clenched fist. Participant X.1 first cut the nails from the hand flat on the table and then cut the nails from the hand holding the object. When the investigator said START the time was started. The time was stopped when the participant cut all five nails from the hand lying flat on the table and said STOP. Similarly

the time for cutting the nails from the hand holding an object with a clenched fist was measured. The cutting of the nails from the hands by participant X.1 was filmed. Participants were asked to cut the nails as secure as possible to prevent participants from cutting each other. The measured times and video file numbers were written down at question 10 and 11 of the Questionnaire Forensic Nail Collector form.

10. Participants X.1 and X.2 swapped places and roles and step 9 was repeated.
11. Participants answered the remainder of the Questionnaire Forensic Nail Collector form at question 12-18.
12. Participants verbally received the debriefing information and were offered a printed (de)briefing form.
13. Experiment was finished and both participants were asked to leave the experiment room.

#### D. NFI expert experiment

The experiment with the forensic expert from the NFI was performed differently. The NFI expert watched the (dis)assembly instruction video and performed the (dis)assembly experiment as described in Step 7 of Section II-C. The resulting (dis)assembly times were analyzed together with the data from the other four duos that received (dis)assembly instructions.

The cutting experiment was performed differently with the NFI expert, to be able to compare the cutting of fingernails with the forensic nail collector prototype and traditional forensic cutting methods using scissors and tweezers. The nails from two nail subjects were cut, with a similar protocol as step 9 from Section II-C. The first nail donor sat at table side 2 and placed both hands with the palm flat on the table behind the screen at table side 1. The forensic investigator first cut the right hand of the nail subject with the traditional forensic cutting method. The forensic investigator was asked to cut all the nails as secure as is done at a crime scene. The nail clippings were photographed on a black background. The nail clippings were stored in a plastic bag marked 'FE1 traditional'. The left hand of the first nail subject was cut using the forensic nail collector prototype. The nail clippings were photographed again and stored in a plastic bag marked

'FE1 prototype'. Now the second nail donor took place at table side 2 with both hands behind the screen at table side 1 clenching the piece of pipe like described in step 9 from Section II-C. The right hand of the second nail donor was cut first by the forensic investigator using the forensic nail collector prototype. The nail clippings were photographed and stored in a plastic bag marked 'FE2 prototype'. The right hand of the second nail donor was cut using traditional forensic cutting methods using scissors and tweezers. The nail clippings were photographed and stored in a plastic bag marked 'FE2 traditional'.

After the cutting experiment with the forensic investigator, advantages and disadvantages of the forensic nail collector prototype compared to traditional forensic cutting methods using scissors and tweezers were discussed. Potential improvements to the forensic nail collector prototype were discussed as well. The number of nail clipping pieces from all four plastic bags was counted, as a measure of nail clipping quality.

#### E. Data analysis

Data acquired during the experiments is stored in three .csv data files. These three data files were imported and further analyzed in Python 3.7 using the Scipy, Numpy, Pandas and Seaborn toolboxes [14].

1) *(Dis)assembly and cutting experiment*: Data from the (dis)assembly experiment was divided in the 'instruction' and 'no instruction' groups. The mean (dis)assembly time was calculated for all 10 tries for both groups. The mean questionnaire score for the first and last (dis)assembly try was calculated for both the 'instruction' and 'no instruction' groups. The mean of the 'flat hand' and 'hand clenching an object' timed- and questionnaire results.

The sample sizes were relatively small ( $n=9&10$ , see Table II) and the timed results of the (Dis)assembly and cutting experiment were not normally distributed. A 95% confidence interval was calculated for all means with 1000 bootstrap iterations.

2) *Questionnaire feedback and experiment video's*: Videos of the participants (dis)assembling the forensic nail collector and participants cutting each others nails with the forensic nail collector were analyzed. Different (dis)assembly and cutting techniques were categorized depending on the assembly order of the forensic nail collector parts.

At the end of the experiment participants were asked to give further recommendations to improve the forensic nail collector prototype. All recommendations from the participants for improvement of the prototype were grouped and ranked by occurrence from most common to least common.

3) *NFI expert experiment*: The NFI experts (dis)assembly results were analyzed together with the (dis)assembly results of the other participant duos. Cutting times of the NFI expert, comparing traditional forensic cutting methods using scissors and tweezers and cutting fingernails with the forensic nail collector prototype are shown in a results table. Potential improvements to improve the forensic nail collector design, discussed with the NFI expert are listed in the results.

### III. RESULTS

#### UNTRAINED PARTICIPANT EXPERIMENT

##### A. Participant characteristics

No participants were excluded from the experiment. Characteristics of the participant group are shown in Table II.

	No instruction	Instruction	Total
Number of participants	10	9	19
Gender [M/F]	8/2	6/3	14/5
Mean age [Year]	24.7	24.9	24.8
Dominant hand [L/R]	1/9	3/6	4/15
Mean hand size, wrist to longest fingertip [mm]	18.6	18.4	18.5
Mean nail Free edge length [mm]	1.5	1.2	1.3

TABLE II  
GENERAL PARTICIPANT DATA LIKE GENDER, AGE, DOMINANT HAND WERE OBTAINED FROM ALL PARTICIPANTS THROUGH A QUESTIONNAIRE. HAND SIZE FROM WRIST TO LONGEST FINGERTIP AND NAIL FREE EDGE LENGTH OF A MIDDLE FINGER WERE MEASURED BY THE INVESTIGATOR.

##### B. (Dis)assembly experiment

The (dis)assembly times are shown in Figure 4 for both the 'instruction' and 'no instruction' participant groups. Progression is visible in Figure 4 during the first three to five tries for both instruction groups resulting in faster and more consistent (smaller spread) (dis)assembly times. In Figure 5 the mean (dis)assembly times of only the first and last (tenth) try are compared. The difficulty score for the first and last (dis)assembly try rated by the participants during the experiment through a questionnaire is also shown in Figure 5.

##### C. Cutting experiment results

The cutting times and questionnaire scores of participants cutting the nails from a hand placed flat on the table and a hand clenching an object (PVC pipe) are shown in Figure 6.

##### D. Data analysis

In Table III is shown if the 95% confidence intervals in Figure 5 and 6 are overlapping.

##### E. Potential improvements to the forensic nail collector prototype mentioned by the participants

The following recommendations were given by the participants, listed from most to least common below:

- High hand force needed to cut nails. Better handle leverage or sharper cutting teeth were opted as solutions. **(Answer frequency = 6)**
- Nails fell out of the container as the opening between the cutting teeth of the forensic nail collector was pointed downwards when cutting the hand holding the object. **(Answer frequency = 5)**
- Smaller radius on cutting teeth so nails should be easier to cut in one large piece. **(Answer frequency = 2)**
- Steel is slippery with sweaty hands. **(Answer frequency = 1)**
- Numbers on both handles representing the assembly order. **(Answer frequency = 1)**

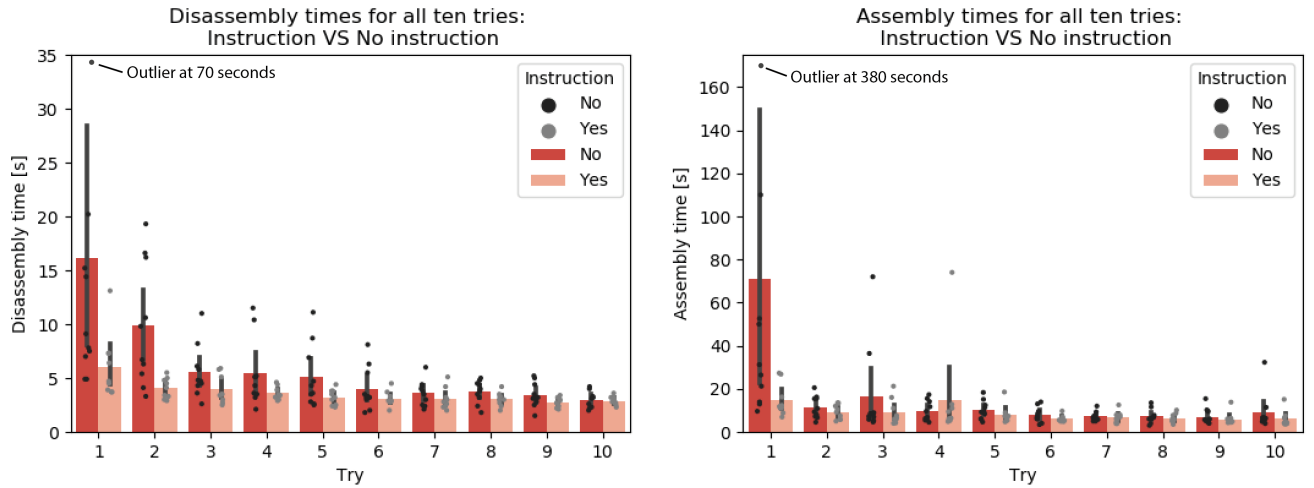

Fig. 4. (Dis)assembly times are compared between participants that received instruction and participants that did not receive instruction. The bars show the mean (dis)assembly time. The line show the 95% confidence interval around each mean. The dots overlaying the barplot show the (dis)assembly times measured during the experiment for each participant for each try. Overlapping dots are randomly spread horizontally to ensure all dots are visible. Left plot show the disassembly times and the right plot shows the assembly times.

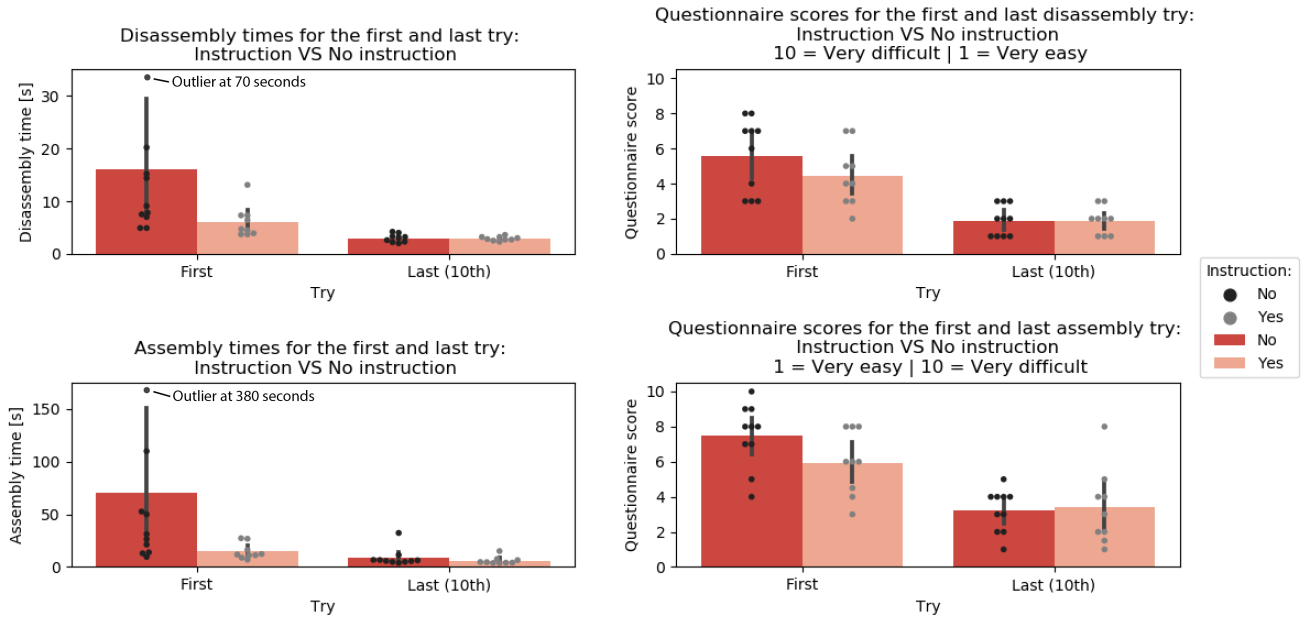

Fig. 5. **Top:** The left plot shows the disassembly time and the right plot the disassembly questionnaire score for the first and last try for both the 'instruction' and 'no instruction' groups. the bars represent the mean disassembly time and questionnaire score. The lines represent the 95% confidence interval around the mean. The dots represent the measured times during the experiment and questionnaire scores of all participants. Overlapping dots are randomly spread horizontally to ensure all dots are visible. **Bottom:** Same as the top graphs, but with the assembly times and assembly questionnaire scores instead.

## IV. RESULTS

### NFI EXPERT EXPERIMENT

#### A. Cutting experiment

The timed cutting results for the NFI expert are shown in Table IV. In Table IV is shown that the NFI expert was faster with the traditional forensic cutting methods compared to cutting with the forensic nail collector prototype. The NFI expert also cut all nails in one or two large pieces with the

traditional forensic cutting methods compared to the multiple small pieces cut with the forensic nail collector prototype.

#### B. Potential improvements discussed with the NFI expert

- Rounder cutting teeth should make cutting the nails in larger pieces easier
- It is difficult to cut the nails deep under the nail
- The nail collector should have a larger handle or sharper teeth so less cutting force is necessary to cut the

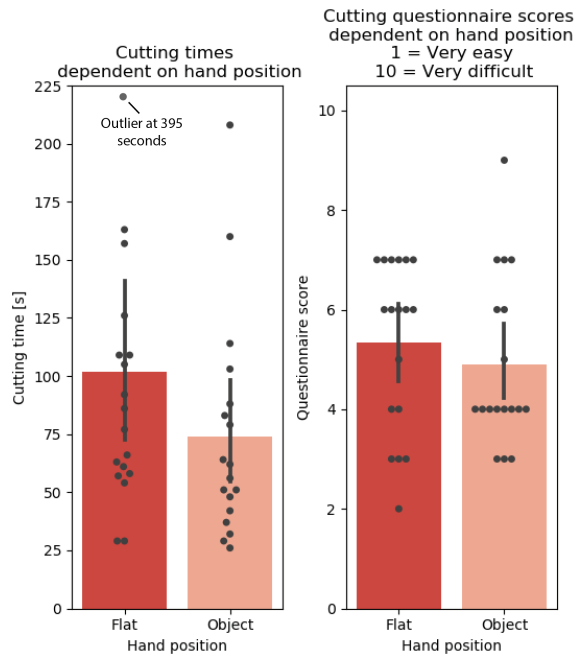

Fig. 6. **Left:** The cutting times measured during the experiment for the participants cutting nails from a hand placed flat on the table and a hand clenching a piece of pipe. The bars represent the mean cutting times. The lines represent the 95% confidence interval around the means. The dots represent the measured cutting times during the experiment of all participants. Overlapping dots are randomly spread horizontally to ensure all dots are visible. **Right:** Same as the left graph, but with questionnaire scores representing the perceived difficulty of the participants cutting nails from a hand laying flat on the table and a hand clenching a piece of pipe.

fingernails.

- The contamination risks with the forensic nail collector prototype were lower. Multiple nails 'jumped' of the nail scissor and fell on the ground. During forensic cases this would have resulted in loss of evidence.
- Nail scissors and tweezers are cleaned with alcohol between each nail. Assembling a new pre-cleaned cutting jaw is faster and cleaner than cleaning the scissor and tweezers with alcohol in the field (they could also use new pre-cleaned scissors and tweezers for each nail but this is not standard procedure yet).

## V. DISCUSSION

The goal of the experiments was to find out how difficult it is to (dis)assemble the forensic nail collector prototype with little experience and to test if participants become faster at (dis)assembling the forensic nail collector over multiple tries. Participants (dis)assembled the nail collector ten times with or without seeing an instruction video to test this.

The 'non instruction' group was slower and had a much larger spread between participants within the group during the first few (dis)assembly tries, see Figure 4. During the last tries (5-10), mean (dis)assembly times were similar between both groups. However, the timed results within the 'no instruction' group were still slightly more spread out than the 'instruction' group.

Between group tests			
	Try	Group	Overlapping 95% CI in Fig. 5
Assembly time	First	'Instruction' VS	No
	Last	'no Instruction'	Yes
Assembly score	First	'Instruction' VS	Yes
	Last	'no Instruction'	Yes
Disassembly time	First	'Instruction' VS	Yes
	last	'no Instruction'	Yes
Disassembly score	First	'Instruction' VS	Yes
	last	'no Instruction'	Yes
Within group tests			
	Try	Group	Overlapping 95% CI in Fig. 5 or 6
Assembly time	First VS last	Instruction	No
	First VS last	No instruction	Yes
Assembly score	First VS last	Instruction	Yes
	First VS last	No instruction	No
Disassembly time	First VS last	Instruction	No
	First VS last	No instruction	No
Disassembly score	First VS last	Instruction	No
	First VS last	No instruction	No
Cutting time	hand VS object		Yes
Cutting score	hand VS object		Yes

TABLE III

DATA ANALYSIS OF THE (DIS)ASSEMBLY AND CUTTING EXPERIMENT. THE TABLE SHOWS IF THE 95% CONFIDENCE INTERVALS FROM FIGURE 5 AND 6 ARE OVERLAPPING.

		Cutting time [s]	Number of nail pieces
Flat hand	Traditional (right hand)	133	6
	Prototype (left hand)	159	13
Object	Traditional (left hand)	89	5
	Prototype (right hand)	104	14

TABLE IV

CUTTING TIMES FROM THE NFI EXPERT CUTTING NAILS FROM A FLAT HAND AND A HAND CLENCHING AN OBJECT WITH BOTH TRADITIONAL FORENSIC CUTTING METHODS USING NAILS SCISSORS AND TWEEZERS AS WELL AS WITH THE FORENSIC NAIL COLLECTOR PROTOTYPE.

It is positive to note that all participants of the 'no instruction' group were able to figure out how to (dis)assemble the forensic nail collector on their own (although one participant needed more than 5 minutes for the first assembly try). The (dis)assembly experiment showed that it is relatively easy to dis(assemble) the forensic nail collector with no or limited experience. During the last five tries almost all participants from both groups were able to disassemble the forensic nail collector between 2 and 5 seconds, and assemble the forensic nail collector between 5 and 15 seconds (see Figure 4). All participants rated the disassembly of the forensic nail collector as (very) easy with questionnaire scores between 1 and 3 (1 = Very easy and 10 = Very difficult). All participant except for one rated the assembly difficulty on the easy side of the scale as well with scores between 1 and 5 (see Figure 5).

There was a noticeable difference in (dis)assembly techniques used between participants from the 'no instruction' group and 'instruction' group. Participants from the 'instruction' group all used the same (dis)assembly technique explained in the instruction video for all ten tries. In the instruction video the top handle is assembled first to the cut-

ting head of the forensic nail collector followed by assembly of the bottom handle. Half of the participants of the 'no instruction' group assembled the bottom handle first to the cutting head of the forensic nail collector and assembled the top handle last. Only one participant of the 'no instruction' group switched techniques (to the technique explained in the instruction video) half way through the experiment.

Participants cut the nails from the hand clenching an object faster than the nails from a hand placed flat on the table, which was not expected. Participants mentioned it was easier to cut the nail from the hand clenching an object due to the nail subjects hand position providing better view on the fingernails and cutting teeth of the forensic nail collector. It is difficult to judge the cutting results seen in Figure 6 as many participants had short nails so, little could be cut. Many participants were also scared to cut each others skin.

The untrained participants and the NFI expert both mentioned that the hand force required to cut fingernails was high. The cutting force at the cutting teeth of a nail clipper was measured by a previous TU Delft project group between 22 and 38 N/mm of nail [15]. The cutting teeth of the forensic nail collector prototype are not made from hardened steel, neither were they sharpened. Sharper and harder cutting teeth should reduce the hand force needed to cut fingernails compared to the hand force required with the current prototype. Handles with more leverage are another possible solution, if further reduction in hand force is required to cut fingernails.

The NFI expert did cut nails slightly faster with the traditional forensic cutting method using scissors and tweezers, see Table IV. This is not a surprise as the NFI expert has cut hundreds or thousands of nails using the traditional forensic cutting methods, but used the forensic nail collector prototype for the very first time. With the traditional forensic cutting methods two out of the 10 nails cut 'jumped' of the scissor and fell on the ground. Nails falling on the ground would be lost evidence on a crime scene. With the forensic nail collector prototype nails were caught in the box. However, the untrained participants and the NFI expert mentioned that nails are able to fall out of the box when the nail collector is held upside down. The NFI expert also mentioned that this problem is easy to circumvent.

With traditional forensic cutting methods using scissors and tweezers the NFI expert was able to cut most of the nails in a single large piece, see Table IV. With the forensic nail collector prototype, the NFI expert cut each nail in multiple smaller pieces. A solution could be sought to ease cutting nails in a single piece with the forensic nail collector. It is also difficult to cut deep enough under the fingernail with the current cutting teeth of the forensic nail collector prototype due to the cutting teeth height and shape. The cutting teeth have been redesigned to follow the rounding of a nail better and to make it easier to cut deep under the fingernails (see Chapter 1).

Lastly, positive feedback from the NFI expert was that with the forensic nail collector prototype it was much easier to cut nails by a single forensic expert than with traditional forensic cutting methods using scissors and tweezers. With

traditional forensic cutting methods often two forensic experts are required to cut fingernails at a crime scene.

## VI. LIMITATIONS

During the (dis)assembly experiments two boxes on the forensic nail collector broke due to forces exerted on the box when (dis)assembling. The disposable boxes are not designed to withstand hundreds of (dis)assembly cycles. However, due to the breaking boxes it was necessary to 3D print extra boxes half way through the experiment. The original boxes were semi-transparent (see Figure 2) and have a wall thickness of 1 mm on all sidewalls and a 0.5 mm bottom wall thickness. The extra 3D printed boxes had a wall thickness of 1.5 mm on all walls for extra strength and were non-transparent black. The extra black boxes used by half of the participant groups may have provided less visibility on the nails and forensic nail collector teeth during the cutting experiment. The cutting jaw was also slightly larger in size due to the larger wall thickness of the extra 3D printed black boxes. The larger cutting jaw may have influenced the maneuverability of the forensic nail collector when cutting fingernails. The influence of the slightly larger non-transparent boxes on the experiment results is expected to have been negligible.

Instructions during the experiment could have been more consistent. Instead of the investigator saying just "START" when starting the stopwatch it would have been more consistent to say "1, 2, START". Some participants started with the forensic nail collector on the table, other participants already held the nail collector in hand when the (dis)assembly timer was started. Similarly, some participants said "STOP" when they had the (dis)assembled forensic nail collector (pieces) in their hand, while other participants said "STOP" when the (dis)assembled forensic nail collector (pieces) were placed on the table. It would have been more consistent when all participants started with the forensic nail collector on the table before the "START" signal and said "STOP" when the forensic nail collector (pieces) were placed (dis)assembled on the table.

Lastly, (dis)assembling the forensic nail collector is a task that may benefit from a high technical insight. The participants participating during the experiment were all students or employees from a technical university, except the NFI expert. The participant group of technical students and employees could have better technical insight than the targeted users (forensic experts and police officers) of the forensic nail collector. However, the NFI expert participating in the experiment had no trouble (dis)assembling the forensic nail collector after watching the short instruction video.

## VII. CONCLUSIONS

A forensic nail collector was further developed and tested. It is very positive that all participant including those not receiving instructions were able to (dis)assemble the forensic nail collector. During the second half of the (dis)assembly experiment all participants (dis)assembled the forensic nail collector fast (within 15 seconds) and participants rated the (dis)assembly difficulty for the last try as easy. There is no

longer any cause of concern that the forensic nail collector would be too difficult to (dis)assemble.

Often heard feedback from the untrained participants and the NFI expert was the high hand force required to cut some nails, difficulties to cut nails in a single large piece and that it is difficult to cut deep under the nail. The cutting teeth of the forensic nail collector have been redesigned to address these feedback points.

The Forensic expert was slightly faster using traditional forensic cutting methods using scissors and tweezers than cutting nails for the first time with the forensic nail collector prototype. However, according to the NFI expert it was much easier and more reliable (less nails falling) to cut nails with the forensic nail collector by a single forensic expert than with the traditional forensic cutting methods using scissors and tweezers.

#### REFERENCES

- [1] M. Matte, L. Williams, R. Frappier, and J. Newman, "Prevalence and persistence of foreign DNA beneath fingernails," *Forensic Science International: Genetics*, vol. 6, pp. 236–243, mar 2012.
- [2] D. A. Engelhart, E. S. Lavins, and C. A. Sutheimer, "Detection of Drugs of Abuse in Nails," *Journal of Analytical Toxicology*, vol. 22, 1998.
- [3] D. Lewis, I. Shu, J. Jones, M. Jones, and A. Negrusz, "Detection of Drugs in Nails: Three Year Experience," *Journal of Analytical Toxicology*, vol. 39, no. 8, pp. 624–628, 2015.
- [4] Dr. Margaret Stark and the Forensic Science Subcommittee, "Recommendations for the collection of forensic specimens from complainants and suspects," *The Faculty of Forensic & Legal Medicine*, January 2019.
- [5] Nederlands Forensisch Instituut, "FT-norm 250.10: Zedendelicten," 2002.
- [6] WHO Department of Gender, Women and Health; WHO Department of Violence and Injury Prevention and Disability, *Guidelines for medico-legal care for victims of sexual violence*. World Health Organization Geneva, January 2003. ISBN 92 4 154628 X.
- [7] K. Little, *A National Protocol for Sexual Assault Medical Forensic Examinations*. U.S. Department of Justice. Office on Violence Against Women, second ed., April 2013.
- [8] L. M. Hebda, A. E. Doran, and D. R. Foran, "Collecting and Analyzing DNA Evidence from Fingernails: A Comparative Study," *Journal of Forensic Sciences*, vol. 59, pp. 1343–1350, sep 2014.
- [9] Amazon.com, Inc, Seattle, United States, "Amazon.com: Online Shopping." <https://www.amazon.com/>, Visited in 2019.
- [10] M. Adriaanse, M. Brouwer, and J. Fajardo, "Medical device prototyping, forensiclip 2.0," 2016. Confidential.
- [11] A. E. Rattenbury, "Chapter 2 - forensic taphonomy," in *Forensic Ecogenomics* (T. Ralebitso-Senior, ed.), pp. 37 – 59, Academic Press, 2018.
- [12] M. Tsokos and R. Byard, "Postmortem changes: Overview," in *Encyclopedia of Forensic and Legal Medicine (Second Edition)* (J. Payne-James and R. W. Byard, eds.), Elsevier, 2016.
- [13] D. de Berker, "Nail anatomy," *Clinics in Dermatology*, vol. 31, no. 5, pp. 509 – 515, 2013.
- [14] Python Software Foundation, "Python version 3.7." <https://www.python.org/>.
- [15] C. Lit, Y. Teeuwen, R. Swart, and J. van der Steenhoven, "Instruments for forensics: Nagelknipper," bachelor thesis project, Delft University of Technology, 2013,2014.



# Bibliography

- [1] Michiel Adriaanse, Max Brouwer, and Jon Fajardo. Medical device prototyping, forensclip 2.0, 2016. Confidential.
- [2] Amatec, Alphen aan den Rijn, Netherlands. Compression springs, 2019. URL <https://www.amatec.nl/en/webshop/compression-springs/D21500>.
- [3] Amazon.com, Inc, Seattle, United States. Amazon.com: Online Shopping. <https://www.amazon.com/>, Visited in 2019.
- [4] Anglevue. Anglevue best nail clipper -doctor design- bend less and see more!, Visited in 2017. URL <https://anglevue.com/>.
- [5] ANSYS, Inc. Ansys AIM 19.0, 2019. URL <https://www.ansys.com/>.
- [6] A van Boeijen, Jaap Daalhuizen, Jelle Zijlstra, and RVD Schoor. Delft design guide. *Delft, Netherlands: Faculteit Industrieel Ontwerpen*, 2010.
- [7] Cynthia M. Cale. Forensic DNA evidence is not infallible. *Nature*, 526(7575):611–611, oct 2015. ISSN 0028-0836. doi: 10.1038/526611a. URL <http://www.nature.com/doifinder/10.1038/526611a>.
- [8] S.R. Choi. Nail clippers, December 31 2014. URL <https://www.google.com/patents/WO2014209066A1?cl=en>. WO Patent App. PCT/KR2014/005,758.
- [9] CustomPartNet. Injection molding process, defects, plastic, Visited in 2019. URL <https://www.custompartnet.com/wu/InjectionMolding>.
- [10] Dassault Systèmes. Solidworks 2018 SP3.0 Education edition, 2019. URL <https://www.solidworks.com/>.
- [11] Discovery Channel, How It's Made. How it's made nail clippers, 2015. URL <https://www.youtube.com/watch?v=1lge7CDMCCs>.
- [12] Dr. Margaret Stark and the Forensic Science Subcommittee. Recommendations for the collection of forensic specimens from complainants and suspects. *The Faculty of Forensic & Legal Medicine*, January 2019. URL <https://fflm.ac.uk/>.
- [13] David A Engelhart, Eric S Lavins, and Craig A Sutheimer. Detection of Drugs of Abuse in Nails. *Journal of Analytical Toxicology*, 22, 1998.
- [14] J. Han and G. Kim. Nail clipper and nail cutter, lever and supporting shaft for the same, June 17 2004. URL <https://www.google.ch/patents/US20040111893>. US Patent App. 10/730,910.
- [15] Lisa M. Hebda, Ashley E. Doran, and David R. Foran. Collecting and Analyzing DNA Evidence from Fingernails: A Comparative Study. *Journal of Forensic Sciences*, 59(5):1343–1350, sep 2014. doi: 10.1111/1556-4029.12465. URL <http://doi.wiley.com/10.1111/1556-4029.12465>.
- [16] kai corporation. and kai industries co. Manufacturing process (nail clippers), Visited in 2018. URL <https://www.kai-group.com/global/en/kai-factory/process/nail-clippers/>.
- [17] Douglas Lewis, Irene Shu, Joseph Jones, Mary Jones, and Adam Negrusz. Detection of Drugs in Nails: Three Year Experience. *Journal of Analytical Toxicology*, 39(8):624–628, 2015. doi: <https://doi.org/10.1093/jat/bkv067>.

- [18] C.J. Lit, Y.A.P. Teeuwen, R.M. Swart, and J.G. van der Steenhoven. Instruments for forensics: Nagelknipper. Bachelor thesis project, Delft University of Technology, 2013,2014.
- [19] Kristin Little. *A National Protocol for Sexual Assault Medical Forensic Examinations*. U.S. Department of Justice. Office on Violence Against Women, second edition, April 2013.
- [20] Junjie Lu. Safety nail clipper, June 24 2015. URL [https://worldwide.espacenet.com/publicationDetails/biblio?II=0&ND=3&adjacent=true&locale=en\\_EP&FT=D&date=20150624&CC=CN&NR=104720264A&KC=A](https://worldwide.espacenet.com/publicationDetails/biblio?II=0&ND=3&adjacent=true&locale=en_EP&FT=D&date=20150624&CC=CN&NR=104720264A&KC=A). CN Patent CN104720264A.
- [21] Melinda Matte, Linda Williams, Roger Frappier, and Jonathan Newman. Prevalence and persistence of foreign DNA beneath fingernails. *Forensic Science International: Genetics*, 6(2): 236–243, mar 2012. ISSN 18724973. doi: 10.1016/j.fsigen.2011.05.008. URL <http://linkinghub.elsevier.com/retrieve/pii/S1872497311001190>.
- [22] Nederlands Forensisch Instituut. FT-norm 250.10: Zedendelicten, 2002.
- [23] A. Preuße-Prange, R. Renneberg, T. Schwark, M. Poetsch, E. Simeoni, and N. von Wurmb-Schwark. The problem of DNA contamination in forensic case work—How to get rid of unwanted DNA? *Forensic Science International: Genetics Supplement Series*, 2(1):185–186, dec 2009. doi: 10.1016/j.fsigs.2009.08.164.
- [24] Protolabs, Inc. Protolabs: Automated design analysis, Visited in 2018. URL <https://www.protolabs.com/automated-design-analysis/>.
- [25] Protolabs, Inc. Protolabs: 6 ways to achieve undercut success in molded parts, Visited in 2019. URL <https://www.protolabs.com/resources/design-tips/6-ways-to-achieve-undercut-success-in-molded-parts/>.
- [26] Amy E. Rattenbury. Chapter 2 - forensic taphonomy. In T.Komang Ralebitso-Senior, editor, *Forensic Ecogenomics*, pages 37 – 59. Academic Press, 2018. ISBN 978-0-12-809360-3. doi: <https://doi.org/10.1016/B978-0-12-809360-3.00002-3>.
- [27] S. van Herk and T.B. Phillips. DEMO interview, September 2018.
- [28] Jaycon Systems. Plastics 101: Selecting the right material for injection molding, 2017. URL <https://medium.com/jaycon-systems/plastics-101-selecting-the-right-material-for-injection-molding-10edb3a8baba>. Visited in 2019.
- [29] TMISHION. Professional stainless steel small nail clipper cuticle cutter nipper with rotate head nail trimmer manicure pedicure tools, 2018. URL <https://www.aliexpress.com/item/1PCs-Professional-Stainless-Steel-Small-Nail-Clipper-Cuticle-Cutter-Nipper-With-32857242424.html?spm=a2g0s.9042311.0.0.27424c4dgbP6uH>.
- [30] M. Tsokos and R.W. Byard. Postmortem changes: Overview. In Jason Payne-James and Roger W. Byard, editors, *Encyclopedia of Forensic and Legal Medicine (Second Edition)*. Elsevier, 2016. ISBN 978-0-12-800055-7. doi: <https://doi.org/10.1016/B978-0-12-800034-2.00312-8>.
- [31] Brenda van Geel. Internship report the forensic nail clippers. Technical report, Delft University of Technology and Nederlands Forensisch Instituut, November 2014. Confidential.
- [32] WHO Department of Gender, Women and Health; WHO Department of Violence and Injury Prevention and Disability. *Guidelines for medico-legal care for victims of sexual violence*. World Health Organization Geneva, January 2003. ISBN 92 4 154628 X.
- [33] Hsin-Chieh Wu, Min-Chi Chiu, and Cheng-Heng Hou. Nail clipper ergonomic evaluation and re-design for the elderly. *International Journal of Industrial Ergonomics*, 45:64–70, feb 2015. ISSN 01698141. doi: 10.1016/j.ergon.2014.12.002. URL <http://linkinghub.elsevier.com/retrieve/pii/S0169814114001693>.
- [34] [www.werktuigbouw.nl](http://www.werktuigbouw.nl). Calculator for round wire helical springs, Visited in 2019. URL <http://werktuigbouw.nl/sub17.htm>.

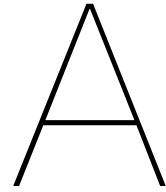

# Usability experiment documents

## **A.1. Usability experiment forms**

## BRIEFING & DEBRIEFING INFORMATION

### FORENSIC NAIL COLLECTOR TESTS

#### Background

After violent crimes, important evidence may be left under the nails of a victim or suspect. Such evidence can consist of DNA, traces of paint or gunshot residues and may be crucial in finding or prosecuting a perpetrator. In order to collect as much of any traces under the nails as possible, the nails are clipped and sent to a lab for forensic analysis.

The Delft University of Technology is developing a novel tool that enables crime scene investigators to safely, easily and reliably collect finger nail samples in all kinds of situations. Today, we ask you to help us discover if and how the current Nail Collector prototype could be improved even further.

#### About the experiment (max. 45 minutes in total)

- 1) You will be given information about this experiment, asked to sign an informed consent form, and will be asked some brief questions about your dominant hand, hand size, age etc..
- 2) You will be given the disassembled prototype and asked to assemble it as fast as possible. We will randomly choose whether you will receive assembly instructions or not prior to starting. You can start assembling when we say; "START", which is when we will start a timer. As soon as you finished assembling the prototype, please put it on the table and say; "STOP", which is when we stop the timer and record your assembly time. You'll do so ten times.
- 3) You have been paired randomly with another participant. You will do this experiment together. One of you will act as "the subject" and the other as "the investigator". The investigator will carefully clip the nails of the subject, while the subject sits behind a screen, having one hand firmly clenched around an object and having the other hand lying flat on the table. The investigator will first clip the nails of the flat hand and then of the clenched hand.
- 4) After all ten nails of the subject have been clipped, the subject and the investigator switch roles and Step 2 is repeated. Both in this step and the previous, we will record the time needed to clip all ten nails.
- 5) Finally, we would like you to fill in a short questionnaire about the assembly and disassembly process, and the use of the prototype.

#### Risks and benefits

Although we instruct all investigators to carefully clip the nails of the subject, there is a minor risk that during clipping someone scratches or slightly cuts the skin of a fingertip. These risks and their consequences are not expected to be any higher than for your own nail clipping habits. By contributing to this experiment you will help us make society safer and our criminal justice system more reliable.

#### What data we collect & what we will do with it

We will record in writing the answers you give in Steps 1 & 5 and any comments you give about the prototype during Steps 2 to 4. We will also record the time it takes to fulfill Steps 2 to 4 and film your hands during these steps. We will **not** record any personal information that could lead back to you, we will **not** collect your nails (these will be disposed of right away, in your presence).

The collected data, entirely anonymized, will be used to analyze the performance of the prototype and to figure out if and how anything should be improved. The results of these studies may be published in scientific journals, media outings, and in reports sent to communicate with our cooperating institutes: the Netherlands Forensic Institute, the Dutch Police and the Dutch Ministry of Justice and Safety.

#### Further information

Please know that you can always withdraw from the tests at any time, for any reason and without giving us a reason. Just say you want to stop and we will immediately abort the test. Also, if you do not want to stop, but would like to take a break or ask something, always feel free to let us know.

If after the experiment there's anything else you would like to know or if you would like to have insight in the data, please contact dr.ir. Arjo Loeve by e-mail ([a.j.loeve@tudelft.nl](mailto:a.j.loeve@tudelft.nl)) or phone (015-2782977).

## Consent Form for Forensic Nail Collector tests

*Please tick the appropriate boxes*

Yes No

### Taking part in the study

I have read and understood the study information dated 14 MAY 2018, or it has been read to me. I have been able to ask questions about the study and my questions have been answered to my satisfaction.

Yes  No

I consent voluntarily to be a participant in this study and understand that I can refuse to answer questions and I can withdraw from the study at any time, without having to give a reason.

Yes  No

I understand that taking part in the study involves having my hands filmed during the experiments, having my nails clipped by another participant, clipping the nails of another participant, filling in a questionnaire and having my comments about the use of the prototype during the experiments written down by the researchers to aid in the improvement of the prototype.

Yes  No

### Risks associated with participating in the study

I understand that taking part in the study involves the following risks: 1) I might accidentally scratch or lightly cut the skin of the fingertips of my fellow participant while clipping their nails. 2) My fellow participant might accidentally scratch or lightly cut the skin of my fingertip while clipping my nails.

Yes  No

### Use of the information in the study

I understand that information I provide will be used for improvement of the design of the forensic nail collector, reports about the forensic nail collector to be published in international journals, patent applications, media outings about the project and internal reports at the Delft University of Technology, Netherlands Forensic Institute, Dutch Police and the ministries involved.

Yes  No

I understand that personal information collected about me that can identify me, such as [e.g. my name or where I live], will **not** be shared beyond the study team.

Yes  No

I agree that my comments on the device, either spoken out during the experiments or written down by me in the questionnaire can be quoted **anonymously** in research outputs

Yes  No

### Signatures

\_\_\_\_\_  
Name of participant [printed]

\_\_\_\_\_  
Signature

\_\_\_\_\_  
Date

I have accurately read out the information sheet to the potential participant and, to the best of my ability, ensured that the participant understands to what they are freely consenting.

\_\_\_\_\_  
Researcher name [printed]

\_\_\_\_\_  
Signature

\_\_\_\_\_  
Date

Study contact details for further info: dr.ir. Arjo Loeve, a.j.loeve@tudelft.nl, 015-2782977

# Questionnaire Forensic Nail Cutter

This questionnaire is part of an experiment where a forensic nail cutter prototype is tested. The collected data collected from this questionnaire, entirely anonymized, will be used to analyze the performance of the nail cutter prototype and to figure out if and how the forensic nail cutter could be improved. The results of these studies may be published in scientific journals, media outlets, and in reports sent to communicate with our cooperating institutes: the Netherlands Forensic Institute, the Dutch Police and the Dutch Ministry of Justice and Safety.

**The following questions are filled in before the experiment by one of the investigators:**

1. Participant number: \_\_\_\_\_
2. Participant age: \_\_\_\_\_
3. Participant gender M/F: \_\_\_\_\_
4. Dominant hand L/R: \_\_\_\_\_
5. Hand size from wrist to longest fingertip in cm: \_\_\_\_\_
6. Nails free edge length in mm: \_\_\_\_\_
7. Filename picture hands: \_\_\_\_\_

**The following questions are filled in during the experiment by one of the investigators:**

8. Instruction video Y/N: \_\_\_\_\_

9. Dis-assemble and assembly time of all 10 tries in seconds:

	1	2	3	4	5	6	7	8	9	10
Disassembly										
Assembly										

10. Filename video (dis)assembly experiment: \_\_\_\_\_
11. Nail cutting experiment times in seconds: \_\_\_\_\_
  - a. 5 fingers flat on table: \_\_\_\_\_
  - b. 5 fingers holding an object: \_\_\_\_\_

The following questions are filled in after the experiment by the participant:

12. <b>Disassembling</b> the nail cutter during the <b>first</b> try was:									
1	2	3	4	5	6	7	8	9	10
Very easy									Very difficult

13. <b>Disassembling</b> the nail cutter during the <b>last</b> try was:									
1	2	3	4	5	6	7	8	9	10
Very easy									Very difficult

14. <b>Assembling</b> the nail cutter during the <b>first</b> try was:									
1	2	3	4	5	6	7	8	9	10
Very easy									Very difficult

15. <b>Assembling</b> the nail cutter during the <b>last</b> try was:									
1	2	3	4	5	6	7	8	9	10
Very easy									Very difficult

16. Cutting fingernails from a hand on a <b>flat table</b> was:									
1	2	3	4	5	6	7	8	9	10
Very easy									Very difficult

17. Cutting fingernail from a hand <b>clenching a piece of pipe</b> was:									
1	2	3	4	5	6	7	8	9	10
Very easy									Very difficult

18. Do you have any further recommendations or ideas for improving the forensic nail cutter design?

---



---



---

## General Instructions

- (Dis)assemble the nail cutter 10 times in the 3 parts seen in the left picture below
- NEVER touch the bottom half of the cutting head! See right picture below
- Do not use excessive force, Do not break the parts
- Cut others nails safely

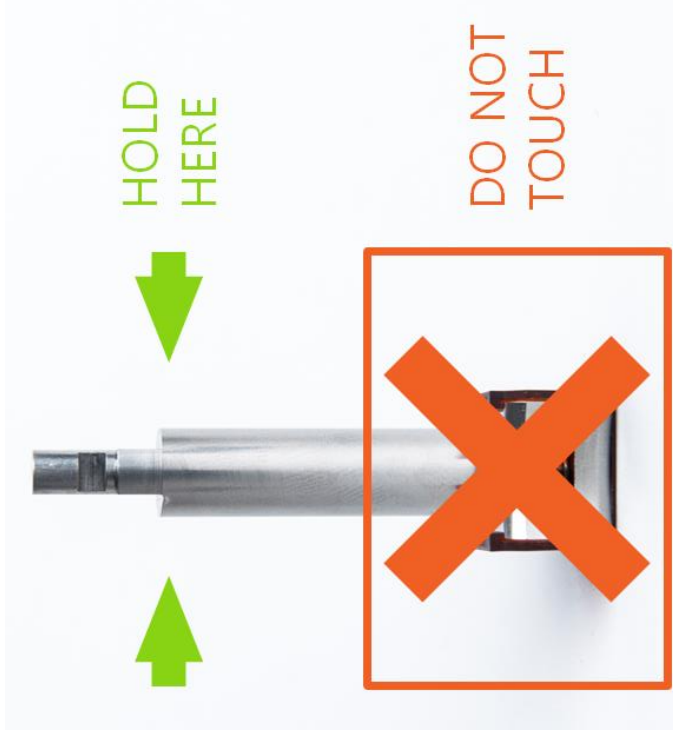

3 nail cutter parts

Do not touch the bottom half of the cutting head

## A.2. Instruction video screenshots

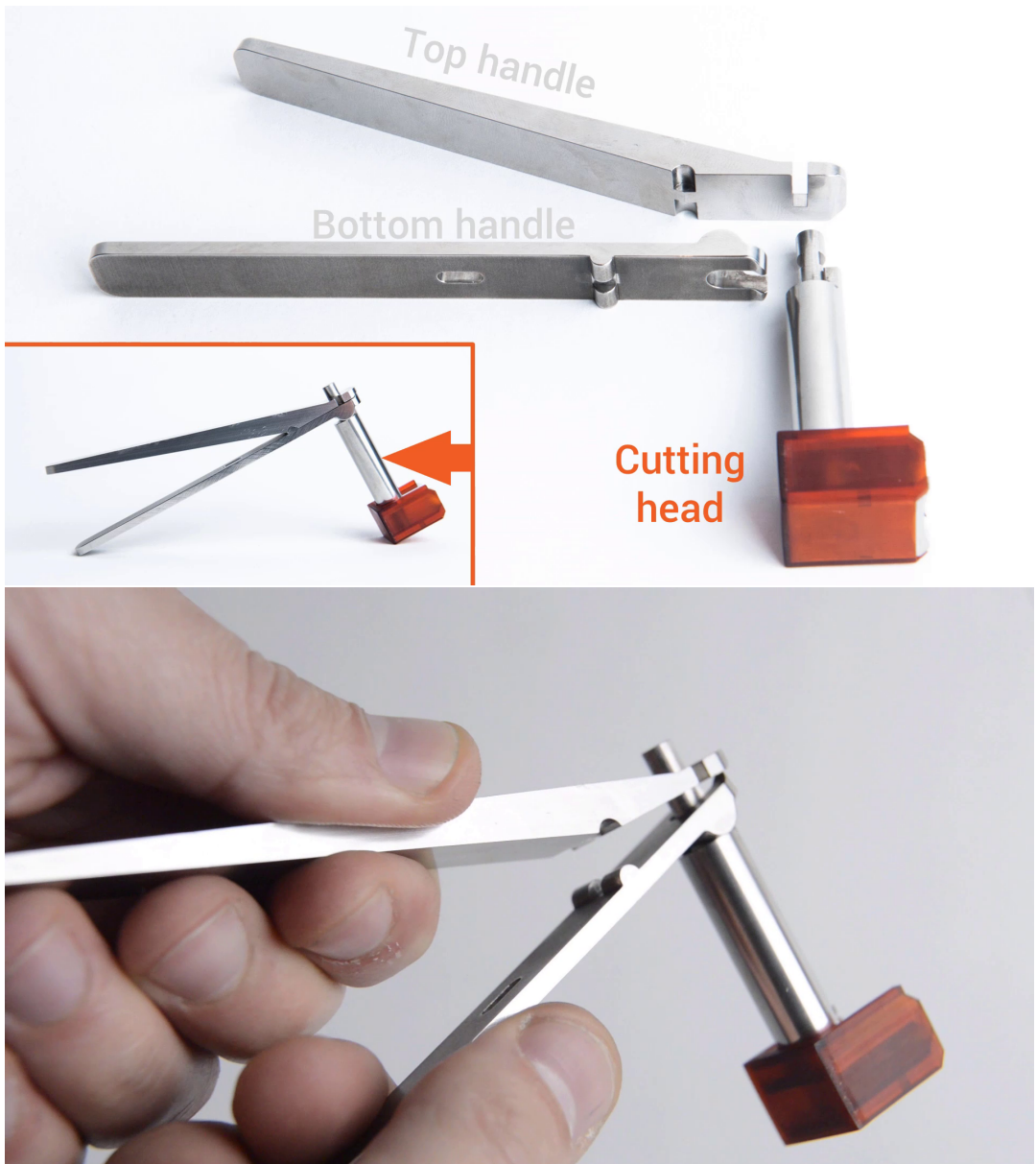

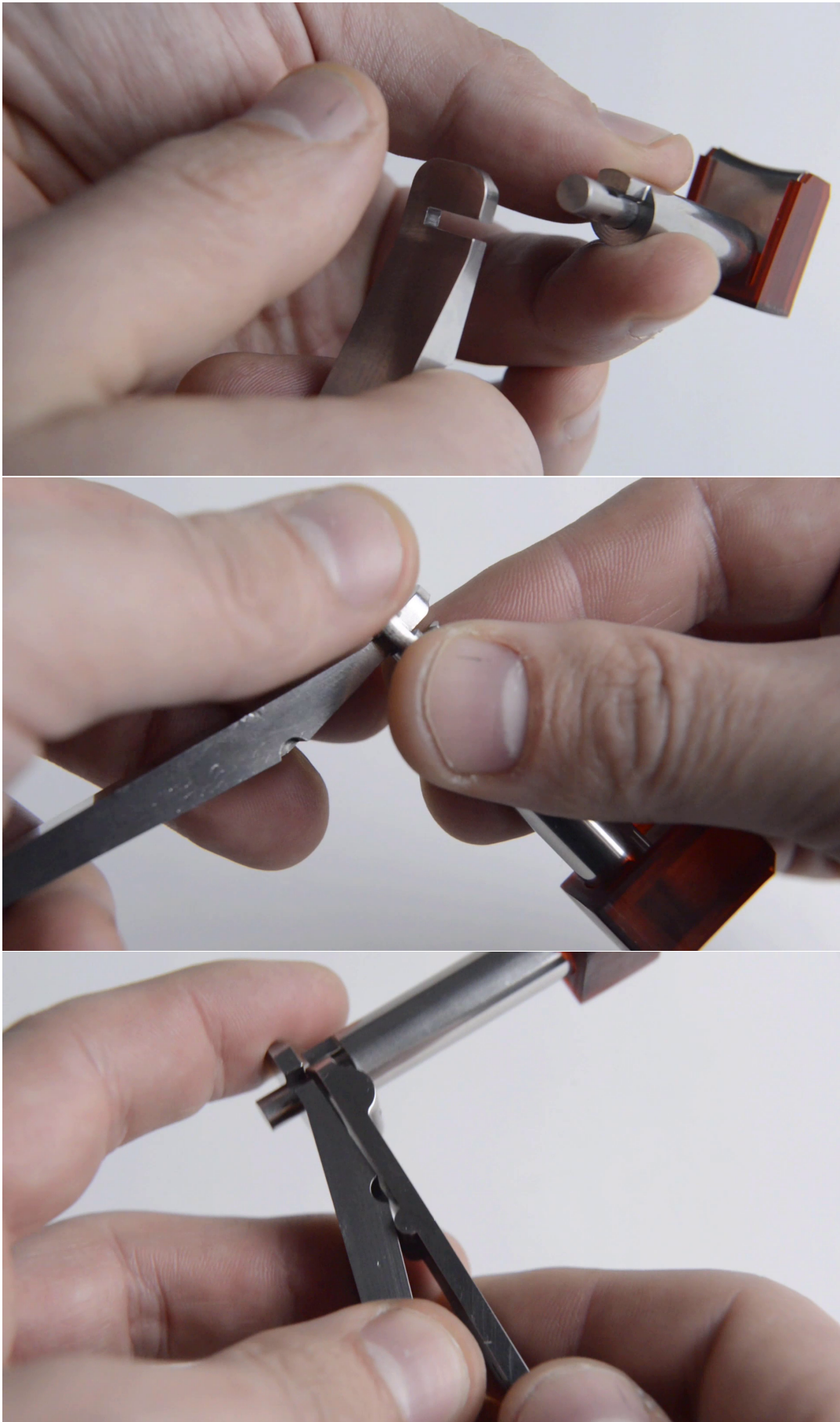

B

Technical drawings: Renewed forensic  
nail cutter

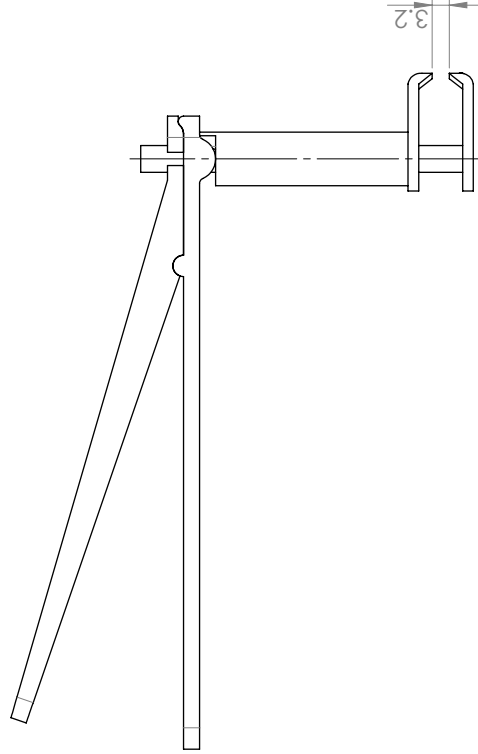
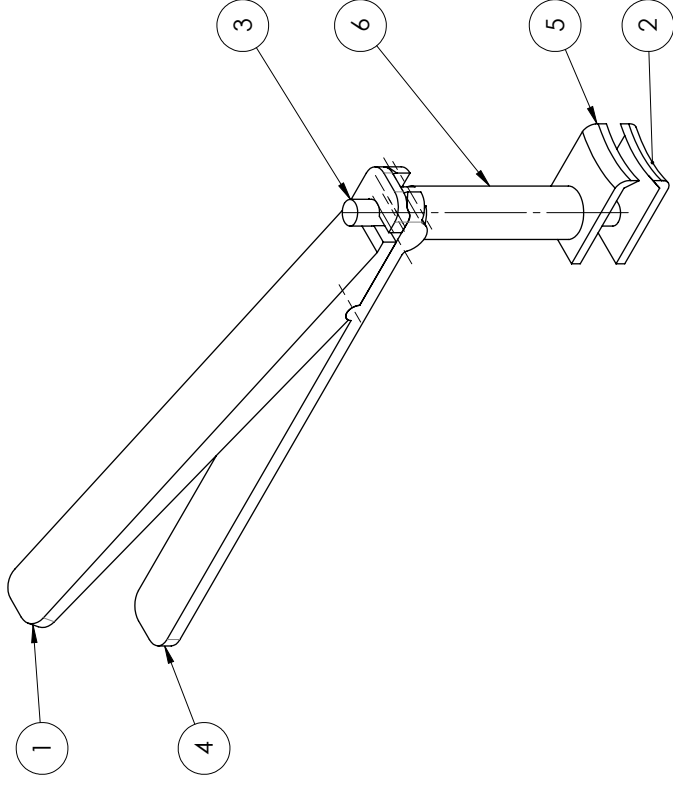

ITEM NO.	PART Name	Drawin NO
1	upper_handle	1B
2	lower_jaw22	4
3	Lower_rod_32	3
4	Lower_handle_new	2
5	top_jaw22	6
6	top_rod_32	5

units	mm	scale	2:1	quantity	1	date	22-Oct-18	remark	Total assembly of the forensic nail cutter
Tolerance: ISO 2768 -mk		author		group		RVS 316 <<group>>			

name **Full\_assembly**

F:\Final Concept\

**TU Delft**  
Delft University of Technology

format **A3** drawing no. **Assem\_full**

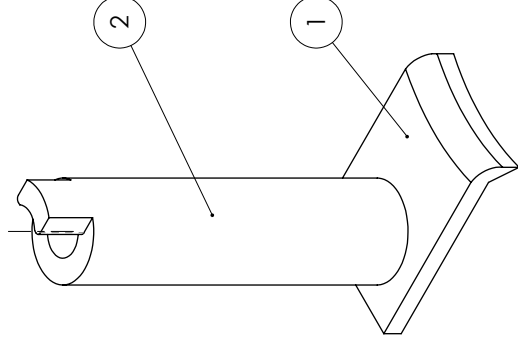
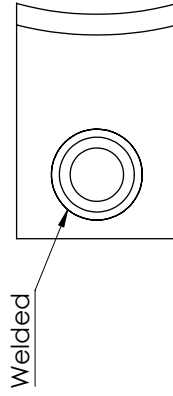
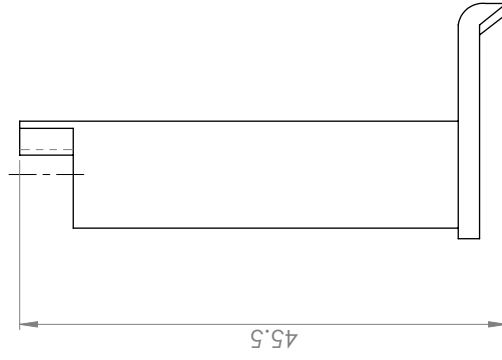
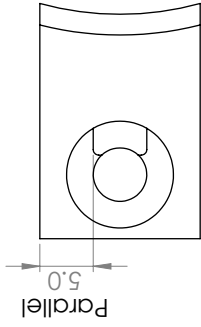

Item NO	Part name	Drawing NO
1	top_jaw22	6
2	top_rod_32	5

	units mm	scale 2:1	quantity 1	date 22-Oct-18	remark Assembly of the top jaw. Item 1 and 2 are welded together.
Tolerance: ISO 2768 -mk		RVS 316		group <<group>>	
author Olaf Dessing (411745)					

name  
**top\_jaw\_assembly**

F:\Final Concept\

**TU Delft**  
Delft University of Technology

format **A3** drawing no. **Assem\_top**

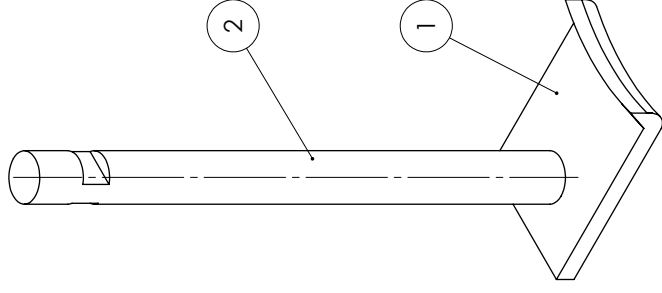
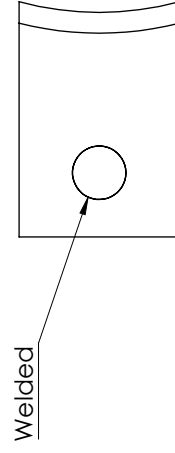
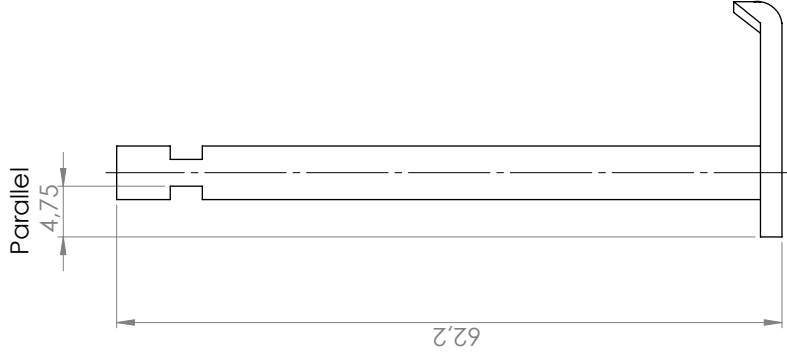

Item NO	Part name	Drawing NO
1	Lower_jaw22	4
2	Lower_rod_32	3

	units	scale	quantity	date	remark
RVS 316	mm	2:1	1	9-10-2018	Assembly of the lower jaw. Item 1 and 2 are welded together
author	Olat Dessing (411745)		mass	gr	
			group	<<group>>	

name **Lower\_jaw\_assembly**

O:\Final Concept\

	format	drawing no.
TU Delft Delft University of Technology	A3	Assem_low

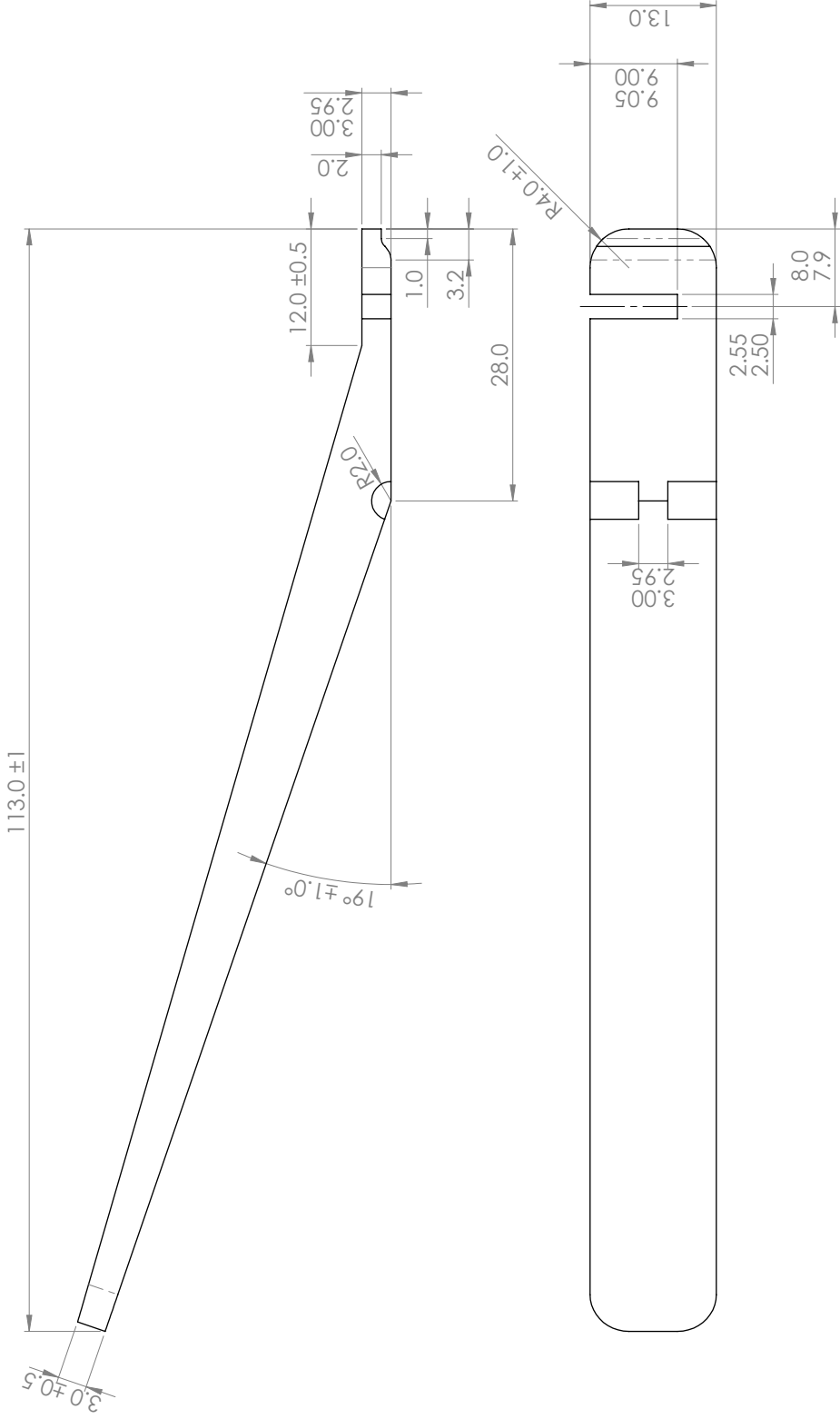

	units	scale	quantity	date	remark
Tolerance: ISO 2768 - mk	mm	2:1	1	16-Oct-18	This part should fit on the existing lower handle. Existing lower jaw should fit in the 2.5 mm slot.
author	Olaf Dassing (4111745)		RVS 316	group	
			<<group>>		

name  
**upper\_handle**

**TU Delft**  
Delft University of Technology

format **A3** drawing no. **1B**

119,5  
117,5

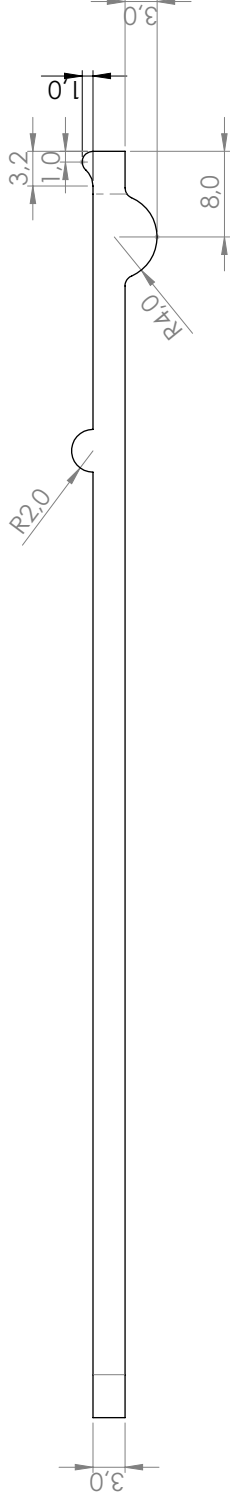
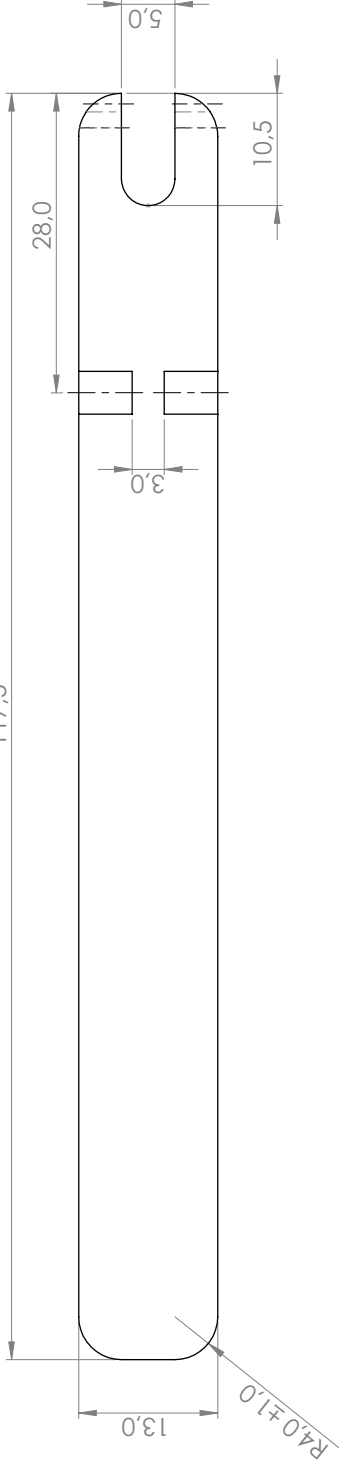

	units	mm	scale	2:1	quantity	1	date	9-10-2018	remark	Should fit with the upper handles (Drawing 1A/B) and top_rod_32
RVS 316	author	Olaf Dassing (411745)			mass	gr	group	<<group>>		

name **Lower\_handle\_new**

O:\Final Concept\



format drawing no.

**A3** 2

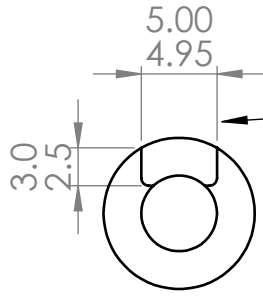

Should fit within the existing lower handle

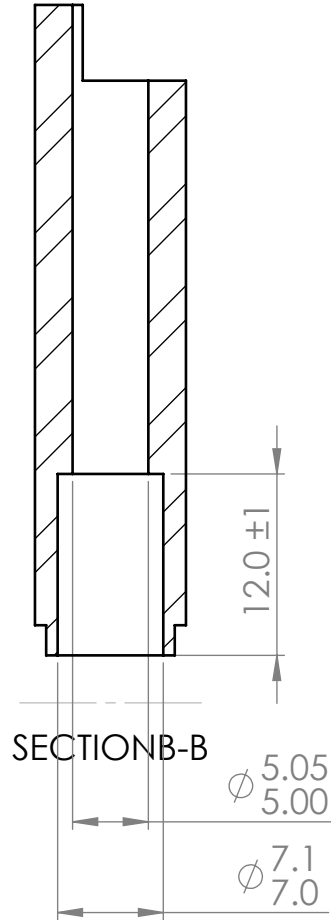
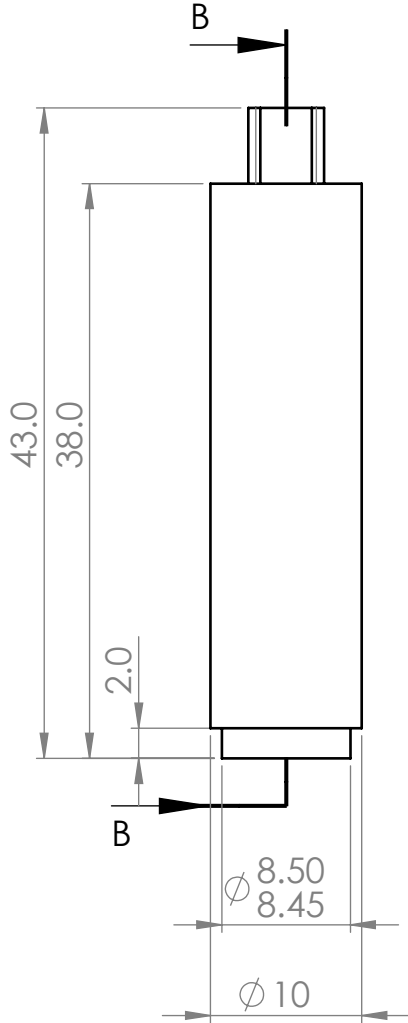

	units mm	scale 2:1	quantity 1	date 16-Oct-18	remark Welded to top_jaw22
Tolerance: ISO 2768 - mk				RVS316	 Delft University of Technology
author Olaf Dessing (4111745)			group <<group>>		
name <b>top_rod_32</b>					format <b>A3</b>
F:\Final Concept\					drawing no. <b>5</b>

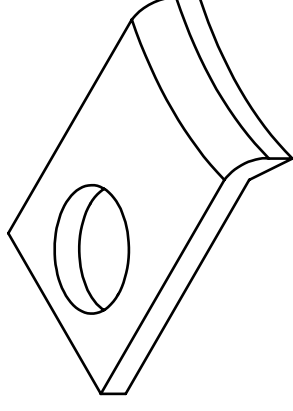
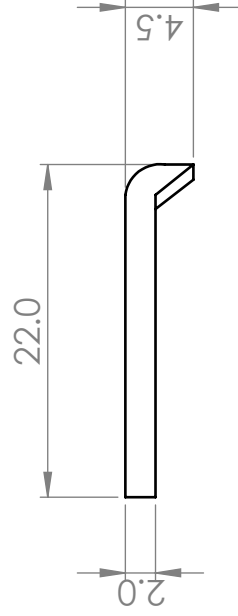
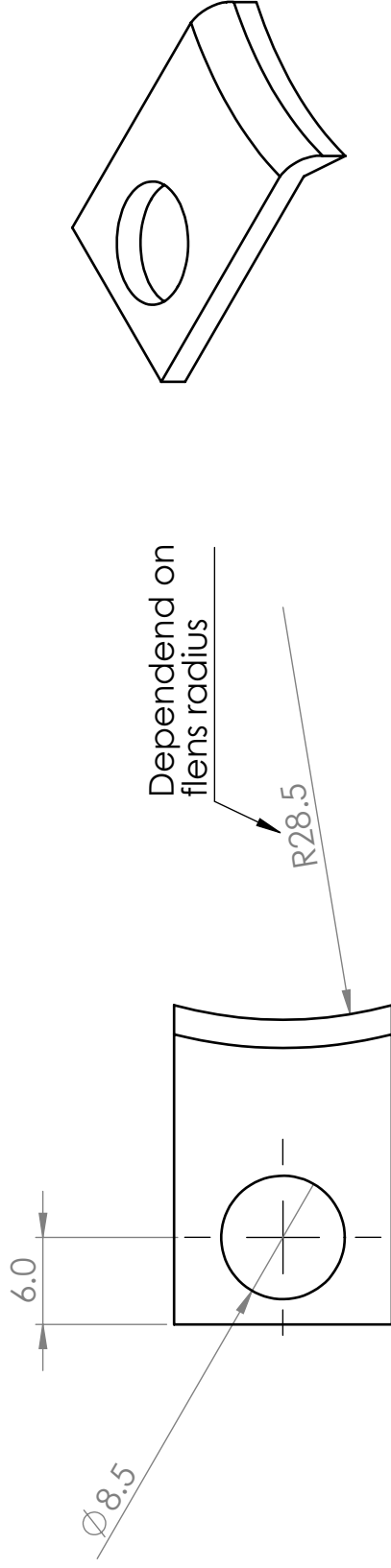

F:\Final Concept\

name



top\_jaw22



Tolerance: ISO 2768 - mk

author Olaf Dessing (4111745)

units mm

scale 2:1

quantity 1

date 16-Oct-18

format A4

remark Welded to top\_rod\_32

group <<group>>

drawing no. 6

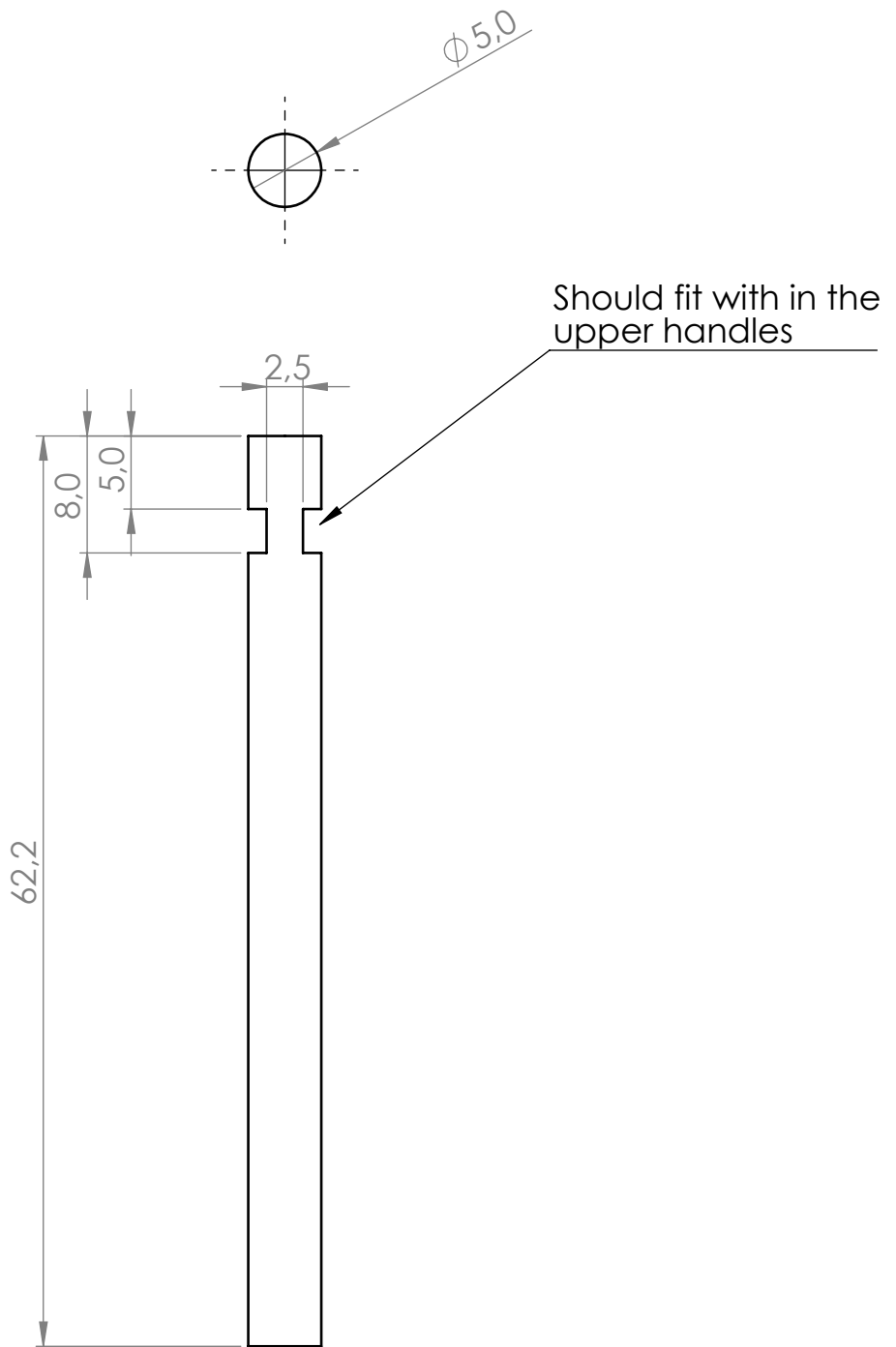

	units mm	scale 2:1	quantity 1	date 9-10-2018	remark Should fit with the upper handles. Welded to lower_jaw22.
RVS 316			mass gr	 Delft University of Technology	
author Olaf Dessing (4111745)			group <<group>>		
name <b>Lower_rod_32</b>				format <b>A3</b>	drawing no. <b>3</b>
O:\Final Concept\					

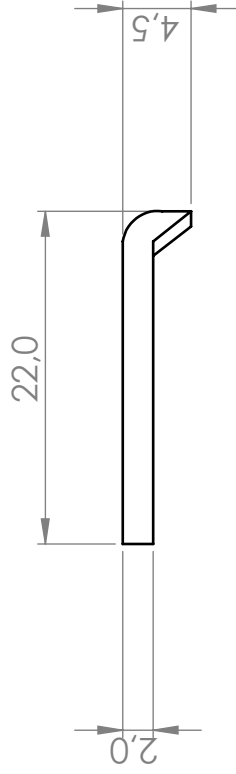
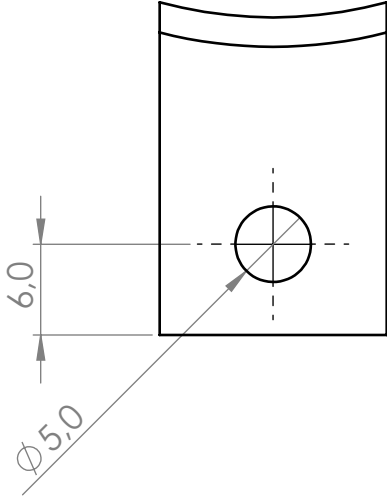
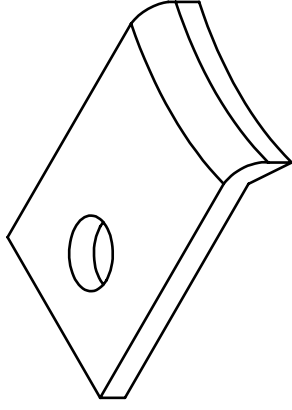

O:\Final Concept\

name



lower\_jaw22



RVS 316

units  
mm

scale  
2:1

quantity  
1

date  
9-10-2018

remark  
Welded to Lower\_rod\_32

author  
Olaf Dessing (4111745)

group  
<<group>>

format  
A4

drawing no.  
4

# C

## Leaf spring retainer

### C.1. Protolabs: automated design analysis of the spring retainers

Upload Date: 11/10/2018

Part Name: prototype1

[ProtoQuote link](#)

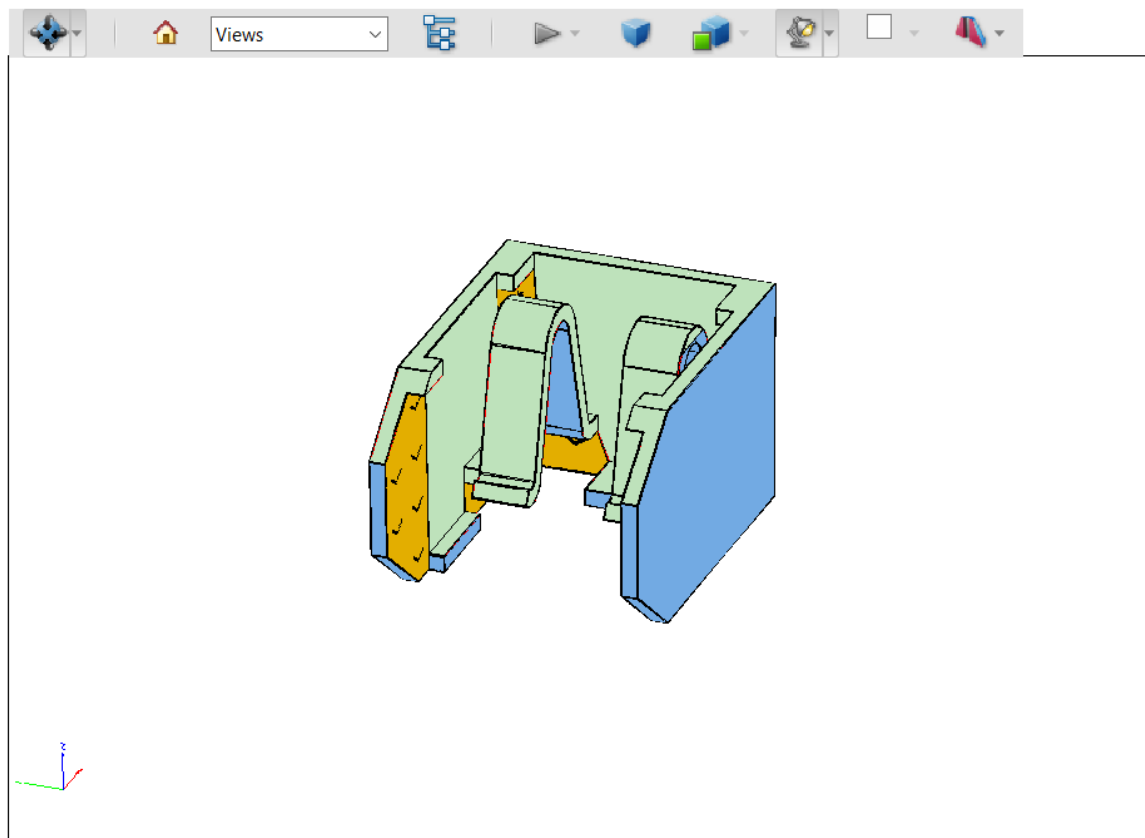

0.5° minimum draft is required on faces with arrows. When adding draft to these features, please maintain the minimum thickness indicated by the colour below:

■ minimum thickness = 0.90 mm

Figure C.1: Screenshot of a Protolabs injection mold design analysis of a similar retainer as shown in Point 2 of Figure 1.15. The draft on the yellow inside walls with the downward pointing arrows was missing.

Upload Date: 23/11/2018 Part Name: overmould\_assembly\_prt

[ProtoQuote link](#)

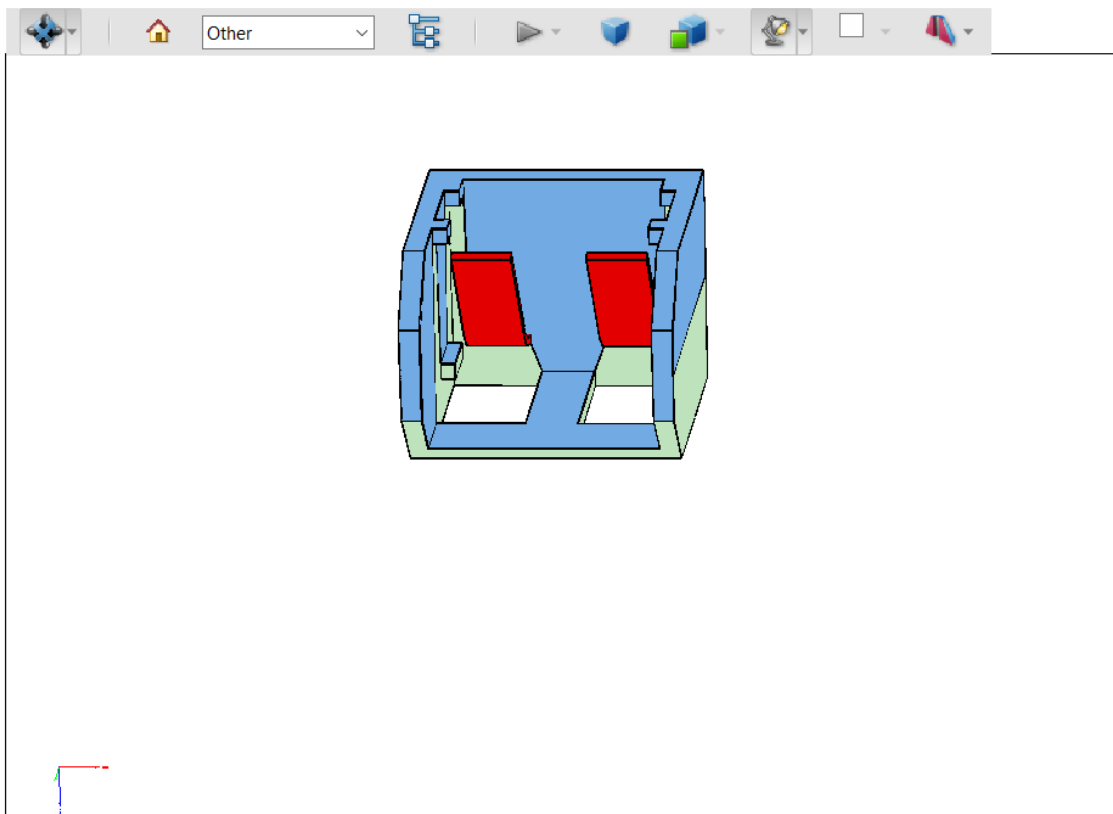

We are unable to mould the insert highlighted due to;  
1- Insufficient location.  
2-Insert is very thin and fragile for our process.

Figure C.2: Screenshot of a Protolabs insert mold design analysis of the forensic nail collector retainer shown in Point 5 of Figure 1.15. The small metal leaf spring was too small and fragile according to the analysis.

## C.2. Spring stiffness analysis with Ansys AIM 19.0

**Spring height = 11.65 mm, Spring angle = 20 degrees, Spring thickness = 1.5mm, Radius = 2.5 mm**

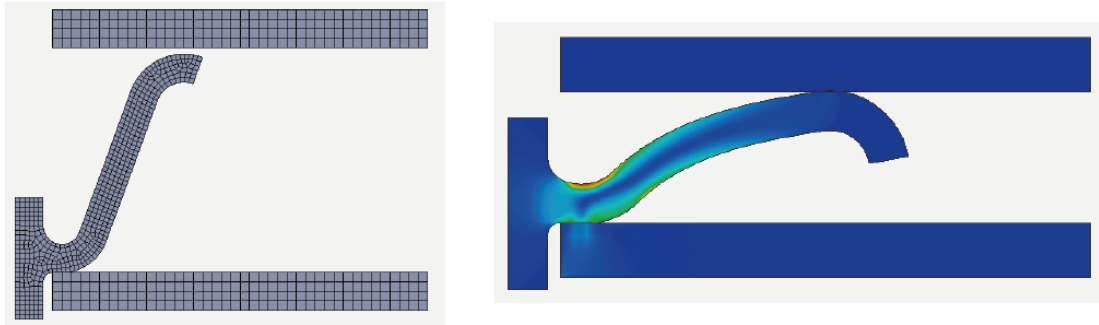

**Spring height = 12 mm, Spring angle = 20 degrees, Spring thickness = 1.5mm, Radius = 4 mm**

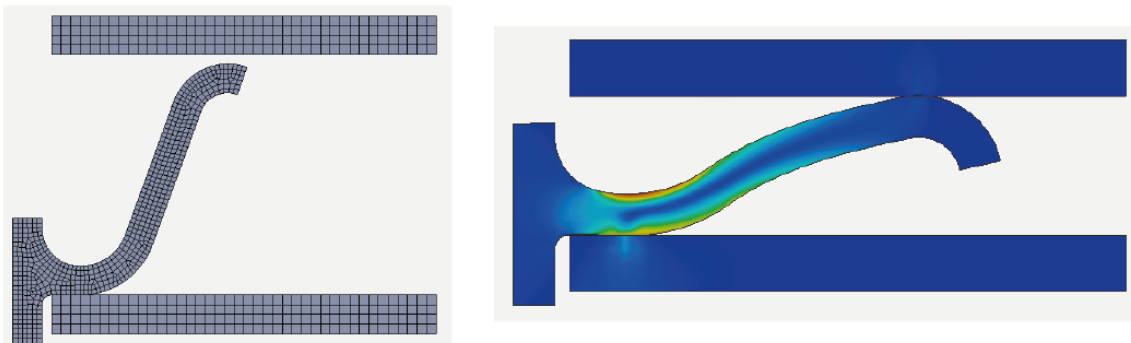

**Spring height = 9.5 mm, Spring angle = 50 degrees, Spring thickness = 1.5mm, Radius = 8 mm**

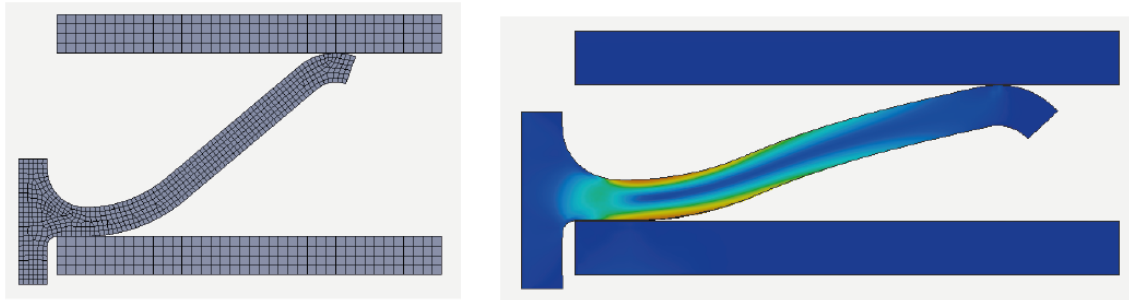

**Spring height = 10 mm, Spring angle = 20 degrees, Spring thickness = 1 mm, Radius = 8 mm**

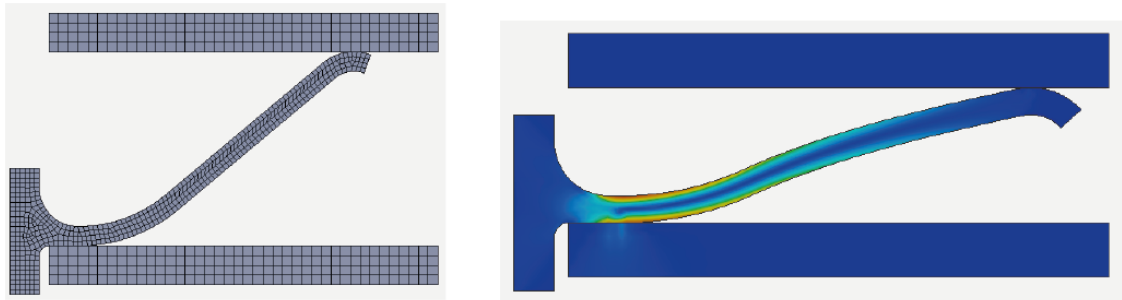
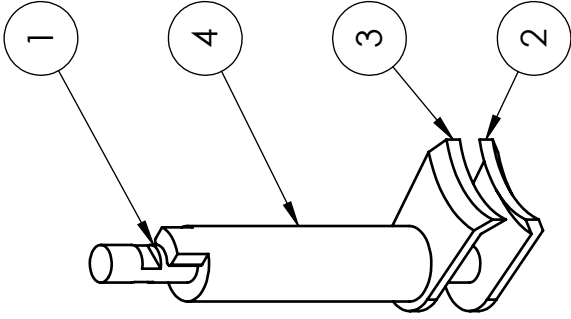

Figure C.3: Five of the springs simulated with Ansys AIM 19.0 are shown in an uncompressed state on the left including their mesh. On the right each simulated leaf spring is shown when compressed to a spring height of 5 mm.

## C.3. Technical drawings: Improved cutting jaw



F:\Final Concept\spring\_box\_v2\

name

**CNC\_assembly**



ITEM NO.	PART NUMBER	DESCRIPTION	QTY.
1	CNC_Lower_rod_32		1
2	CNC_tandje_bottom		1
3	CNC_tandje_top		1
4	CNC_top_rod_32		1

 units mm scale 1:1 Tolerance: ISO 2768 - mk	quantity 1	date 21-Jan-19	remark
	group <<group>>		format A4
author Olaf Dessing (4111745)		drawing no. Assembly	

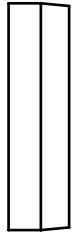
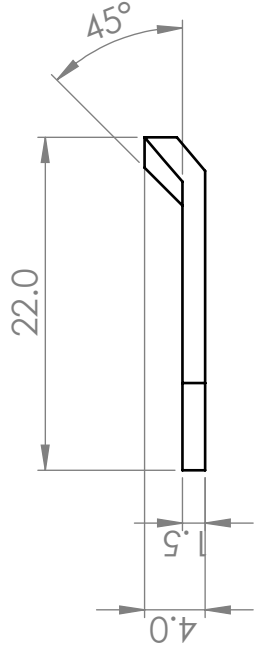
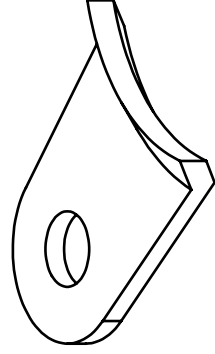
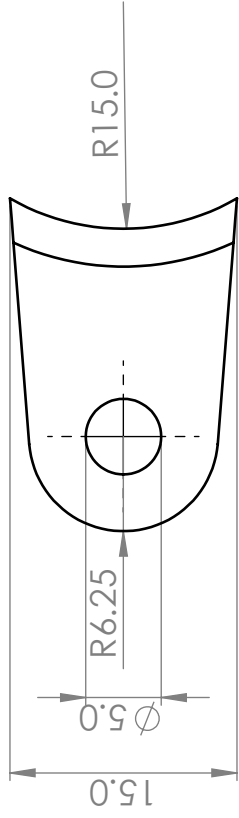

F:\Final Concept\spring\_box\_v2\

**TU Delft**  
Delft University of Technology

**CNC\_tandje\_bottom**

name



Tolerance: ISO 2768 - mk

author Olaf Dessing (4111745)

units mm

scale 2:1

quantity 1

date 21-Jan-19

remark

group <<group>>

format

**A4**

drawing no.

**2**

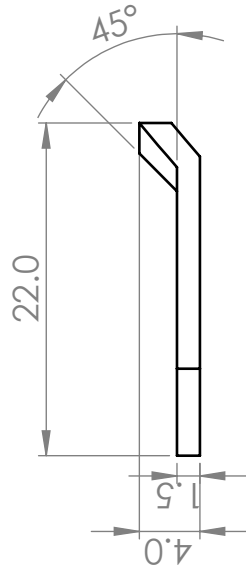
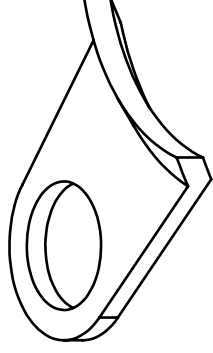
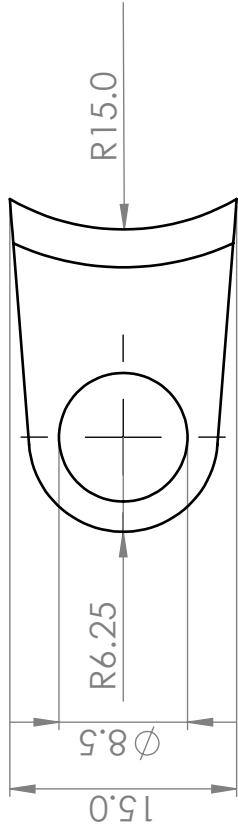

F:\Final Concept\spring\_box\_v2\

name

**CNC\_tandje\_top**



Tolerance: ISO 2768 - mk

author Olaf Dessing (4111745)

units mm

scale 2:1

quantity 1

date 21-Jan-19

remark

group <<group>>

format

**A4**

drawing no.

**3**

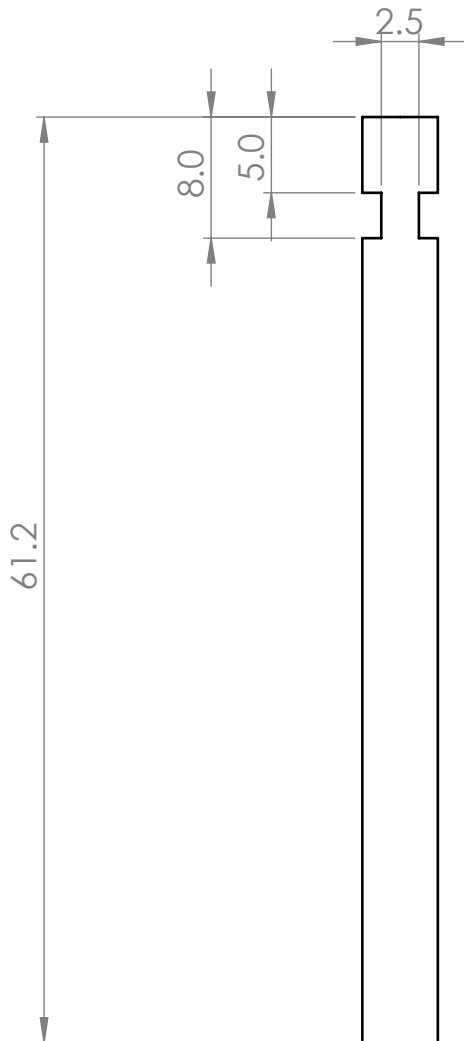
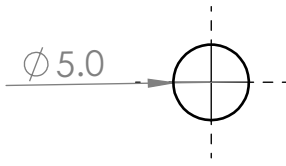

	units mm	scale 2:1	quantity 1	date 21-Jan-19	remark
Tolerance: ISO 2768 - mk				RVS 316	 Delft University of Technology
author Olaf Dessing (4111745)			group <<group>>		
name <b>CNC_lower_rod_32</b>				format <b>A3</b>	drawing no. <b>4</b>
F:\Final Concept\spring_box_v2\					

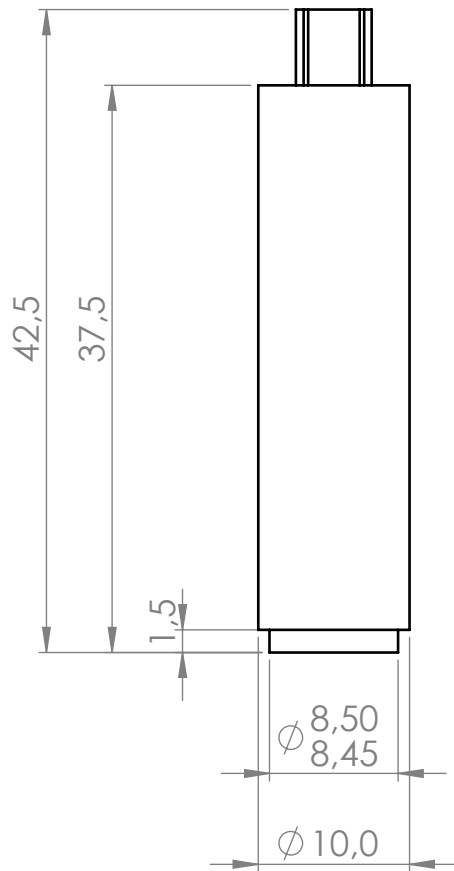
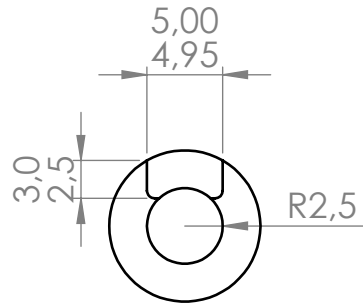

	units mm	scale 2:1	quantity 1	date 31-1-2019	remark	
Tolerance: ISO 2768 - mk				RVS 316	 Delft University of Technology	
author Olaf Dessing (4111745)			group <<group>>			
name <b>CNC_top_rod_32</b>					format <b>A3</b>	drawing no. <b>4</b>
O:\Final Concept\spring_box_v2\						

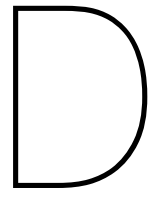

Drop experiment

# Forensic nail collector retainer test: The risk of nail samples dropping out of the retainer?

Olaf Dessing and supervisor dr. ir. Arjo Loeve

**Abstract**—Nail clippings are stored in the box retainer around the forensic nail collector cutting jaw. The only opening of the cutting jaw retainer is the opening between the two cutting teeth. The nail clippings are not allowed to fall out of the cutting jaw retainer, as the nail clippings falling would contaminate potential evidence present on the nail clippings. It is unknown how easy the nail clippings fall out of the cutting jaw retainer. Two cutting jaw retainers with an opening of  $46.2\text{mm}^2$  and  $14.5\text{mm}^2$  were filled with one, five or ten fingernails and shook in three different orientations and shake directions. A smaller opening between the cutting teeth resulted in a slightly lower chance of nail samples falling out of the cutting jaw retainer. Most nail clippings fell out of the retainer when the cutting jaw was rotated to a downward facing orientation. This is concerning as rotation of the cutting jaw to a downward facing orientation can accidentally happen at a crime scene with ease.

## I. INTRODUCTION

The current forensic nail collector prototype consists of a cutting jaw with a plastic box retainer around the cutting jaw. Between the cutting teeth there is a small opening. This opening is needed to cut the fingernail by placing the fingernail in between both cutting teeth. However, this opening also allows nail samples in the retainer to fall out through this opening between the cutting teeth. The cut nail samples should not fall out of the retainer as contact with for example the ground can potentially contaminate the nail sample. The goal of this experiment was to find out how much a smaller opening between the cutting teeth reduces the risk of nail clippings falling out of the retainer.

## II. MATERIALS & METHODS

Two different cutting jaws from the latest (cutting jaw A) and second latest (cutting jaw B) forensic nail collector prototypes were used, see Figure 1. Cutting jaw A has an opening height of 3.1 mm and a width of 14.9 mm, resulting in an opening area of  $46.2\text{mm}^2$ . Cutting jaw B has an opening height of 1.0 mm and a width of 14.5 mm, resulting in an opening area of  $14.5\text{mm}^2$ . The authors 10 fingernails were used. The largest fingernail had a length of 2.65 mm and a width of 14.80 mm. The smallest fingernail had a length of 1.65 mm and a width of 8.50 mm.

Both cutting jaw A and B shown in Figure 1 were tested by shaking the cutting jaw in an upward, forward and downward facing orientation shown in Figure 2. Each orientation was tested with four different retainer contents: One small pink fingernail, one large thumb fingernail, five fingernails from one hand and all ten fingernails from both hands. The cutting jaw is shaken for each orientation in a upward direction, forward direction and sideways direction, shown in Figure 2.

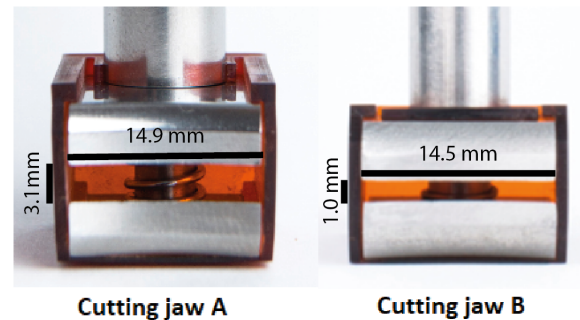

Fig. 1. Cutting jaw A and B used during the experiments.

each combination of cutting jaw, orientation, shake direction and retainer contents was tested five times. The number of nails that fell out of the retainer during the five repetitions was counted. First all tests with only the same pink nail were performed with both cutting jaw A and B, followed by all tests with only a large thumb nail to ensure that the same two nails were used during all experiments. All tests with 5 nails from one hand were done next to ensure the same 5 nails were used during all experiments. All tests with all 10 nails from both hands were performed last.

There is one extra shaking option for the downward facing orientation named 'No shaking'. The cutting jaw retainer was filled in the upward facing orientation and then slowly rotated to the downward facing orientation. The number of nails falling out of the cutting jaw when rotating the cutting jaw to the downward facing orientation were counted.

## III. RESULTS

Table I shows the number of nail clippings that fell out of each retainer. When none of the nail clippings fell out of the retainer during any of the five repetitions a green box is shown in Table I. When during all five repetitions at least one nail clipping fell out of the retainer while shaking, a red box is shown in Table I. An orange box is used in Table I when nail clipping(s) fell out of the retainer during some (but not all) five repetitions. The minimum and maximum amount of nail clippings that fell out of the box during all five repetitions is also listed in table I.

## IV. DISCUSSION & LIMITATIONS

The goal of this experiment was to find out how much a smaller opening between the cutting teeth reduces the risk of nail clippings falling out of the retainer. Table I shows that more nail clippings fell out of cutting jaw A compared to

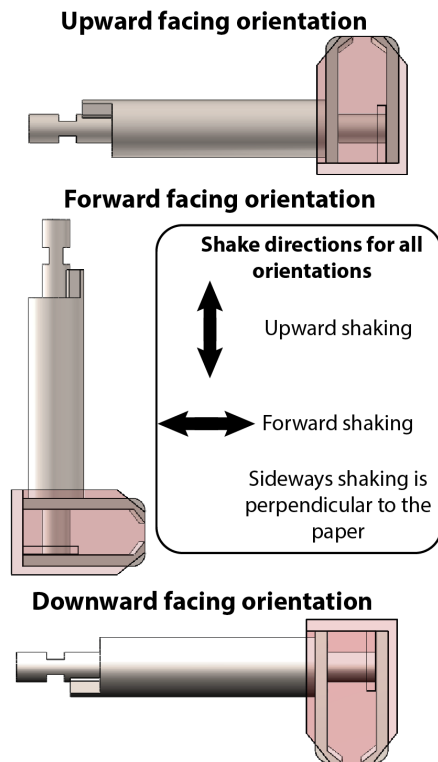

Fig. 2. The cutting jaw of the forensic nail collector is shown in a 2D plane for all three orientations. The shake direction is the same for all cutting jaw orientations.

cutting jaw B while shaking the cutting jaws in the directions and orientations shown in Figure 2. The smaller cutting jaw opening of cutting jaw B seems to have a relatively limited effect in reducing the number of nail clippings that fell out of the cutting jaw. The larger opening of cutting jaw A is also necessary to ease cutting with the forensic nail collector as the opening height of 1 mm of cutting jaw B is already too small to cut the authors thumbnail. Table I shows that nail clippings fell the easiest out of the cutting jaw retainer held in a downward facing orientation and the least nail clippings fell out of the cutting jaw retainer held in an upward facing orientation. Nail clippings were most likely to fall out of the retainer when the shake direction and opening orientation were aligned.

It is concerning that the nail clippings often fall out of the retainer when rotating the cutting jaw to a downward facing orientation. A scenario like this can easily happen during a forensic investigation where the forensic investigator accidentally rotates the filled cutting jaw retainer to a downward facing orientation.

The shaking performed during these tests are not likely to happen at a crime scene, except for a forensic investigator accidentally rotating the nail cutting jaw to a downward position. In general nail clippings fell out of the box retainers with relative ease. Solutions that prevent nail clippings from falling out of the retainer can further improve the design of

*Cutting Jaw A: opening area 46.2 mm<sup>2</sup>*

Orientation	1 pink nail	1 thumb nail	5 nails	10 nails
Upward Orientation	1 pink nail	1 thumb nail	5 nails	10 nails
Sideways shaking	0	0	0	0
Forward shaking	0	0	0	0
Upward shaking	1	1	5	1-8
Forward Orientation	1 pink nail	1 thumb nail	5 nails	10 nails
Sideways shaking	1	1	5	1-9
Forward shaking	1	1	5	1-9
Upward shaking	0-1	0-1	2-4	0-1
Downward Orientation	1 pink nail	1 thumb nail	5 nails	10 nails
No shaking	1	1	4-5	0-4
Sideways shaking	1	1	5	10
Forward shaking	1	1	5	10
Upward shaking	1	1	5	10

*Cutting Jaw B: opening area 14.5 mm<sup>2</sup>*

Orientation	1 pink nail	1 thumb nail	5 nails	10 nails
Upward Orientation	1 pink nail	1 thumb nail	5 nails	10 nails
Sideways shaking	0	0	0	0
Forward shaking	0	0	0	0
Upward shaking	1	0-1	1-5	1-3
Forward Orientation	1 pink nail	1 thumb nail	5 nails	10 nails
Sideways shaking	1	1	1-5	1-4
Forward shaking	1	1	1-4	1-5
Upward shaking	0-1	0-1	0-2	0-2
Downward Orientation	1 pink nail	1 thumb nail	5 nails	10 nails
No shaking	1	0-1	0-3	0-2
Sideways shaking	1	1	4-5	2-8
Forward shaking	1	1	4-5	1-5
Upward shaking	1	1	5	10

TABLE I

NUMBER OF NAIL CLIPPINGS THAT FELL OUT OF THE BOX WHEN SHAKING CUTTING JAW A AND B.

the forensic nail collector.

Cutting jaw A and B were used as they both have different sized openings between the cutting teeth. However, these cutting jaws do not have the exact same geometry. The differences in cutting jaw geometry between cutting jaw A and B may have influenced the results. The shaking intensity was not 100% consistent and the shaking direction was not 100% sideways, forward or upwards as it was performed by hand.

## V. CONCLUSIONS

Two different cutting jaw retainers with an opening of 46.2 mm<sup>2</sup> and 14.5 mm<sup>2</sup> were tested during this experiment. The cutting jaw with the larger opening allowed more nail clipping to fall out of the cutting jaw retainer than the cutting jaw with the smaller opening. Most nail samples will easily fall out of the forensic nail collector retainer, when the nail collector is slowly rotated with the opening to a downward facing orientation. The forensic nail collector rotated with the opening to a downward facing orientation could happen accidentally at a crime scene.