

Effect of Steering Model Fidelity on Subjective Evaluation of Truck Steering Feel

Barys Shyrokau¹, Jan Loof², Olaf Stroosma¹, Meng Wang¹, Riender Happee¹

(1) Delft University of Technology, Mekelweg 2, 2628 CD Delft, The Netherlands,
e-mail: {B.Shyrokau, O.Stroosma, M.Wang, R.Happee}@tudelft.nl

(2) Eindhoven University of Technology, Den Dolech 2, 5600 MB Eindhoven, The Netherlands,
e-mail: J.Loof@tue.nl

Abstract – *The steering behaviour in a driving simulator has a significant influence on a driving realism. This study investigates the influence of the complexity of a steering-system model on the subjective assessment of truck steering feel in on-centre handling. Ten subjects drove a highway task with and without lateral wind disturbance with 4 steering-system model variants. The results show that detailed modelling of the steering system plays a significant role in the subjective assessment of truck steering feel, and has a corresponding effect on objective steering performance.*

Keywords: *truck steering feel, steering model, subjective assessment, on-centre handling, driving simulator.*

Introduction

The steering behaviour in a driving simulator is one of the key elements to achieve a realistic driving environment. To reach realistic behaviour, all components like vehicle modelling, proper visualization, motion cueing and others play a significant role. Within the investigation of on-centre vehicle handling the recreation of steering feel becomes the most important issue and one of the most critical contributions to a steering realism is related to a precise steering-system model.

Meanwhile, the steering realism in a driving simulator is limited by the realism of the applied model of the vehicle and the steering system, by the hardware of the steering actuator and the requirements of real-time computation. The trade-off between the complexity of the steering model, technical characteristics of the steering actuator and real-time performance define steering behaviour in a driving simulator.

On-centre handling is of critical importance in truck-trailer combinations where lane keeping precision is of vital importance, and several truck accident scenarios are related to steering.

Advanced truck simulators have been developed, with vehicle models being validated in terms of kinematics, but only limited validation is reported of the steering feel of truck driving simulators [Saa03, Haa06].

Aim of this study

Based on the hypothesis that a driver as a human being might not feel any difference in steering realism after a certain level of the complexity of a steering model, this paper investigates the influence of the complexity of a steering model on subjective steering feel for truck on-centre handling.

Method

Participants

The test group consisted of 10 male drivers with an average age of 28.3 years (SD=4.4). They were recruited from the student and employee community at TU Delft. On average participants had their driving license for 8 years (SD=6.2) and graded their own driving skills with a mean of 5.2 (SD=0.64), on a scale between 1 and 7, where 1 being incompetent and 7 being an expert driver. The test group of the drivers included persons with and without an experience in commercial vehicle driving.

Apparatus

Driving Simulator

To investigate the research question, a fixed-based driving simulator was used. It consists of a steering wheel, throttle and brake pedals and single seat. A feedback force to steering wheel is generated by the steering actuator FCS CLU 97001. It includes a brush type DC electric motor, a position transducer (encoder – relative type), a tachometer, a torque

transducer, a harmonic drive gearbox with a gearing ratio of 50:1 and an amplifier unit for electric motor and transducers. The continuous torque of the actuator is 24 Nm and peak torque is 56 Nm. The detailed technical specification are given in [Pos03].

The driving simulator is shown in Figure 1. It is operated by in-house developed middleware software DUECA [Paa00] and has a multi-node PC configuration including (Figure 2):

- a multi-body model of a commercial vehicle (truck with semitrailer) up to 50 DOF [Eve09] was adopted and enhanced. The tire model is based on Pacejka’s non-linear tire model with relaxation behaviour. Simulink Coder was used to generate C code from SimMechanics diagrams;
- four steering-system model variants as described below.
- an IO interface related to steering actuator and pedals;
- data logging and scenario interface;
- visualisation environment via PreScan software.

The horizontal field of view of 180° is generated by three projectors (BenQ W1080ST) or via Oculus Rift. The resolution is 1,920 x 1,080 pixels at a refresh rate of 60 fps, which together with a sufficiently high frame rate guarantees a smooth visual projection throughout the experiment.

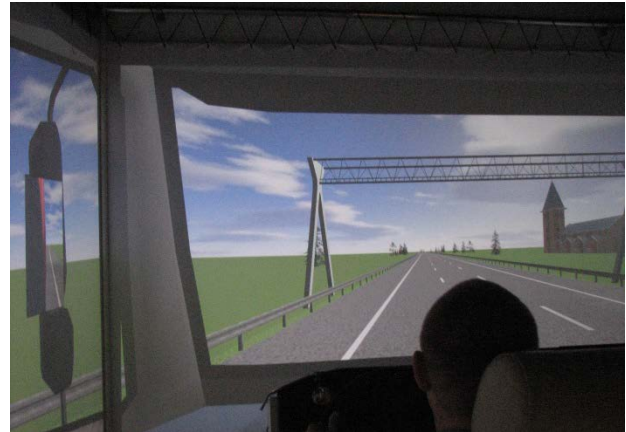

Figure 1. Photograph of the truck driving simulator

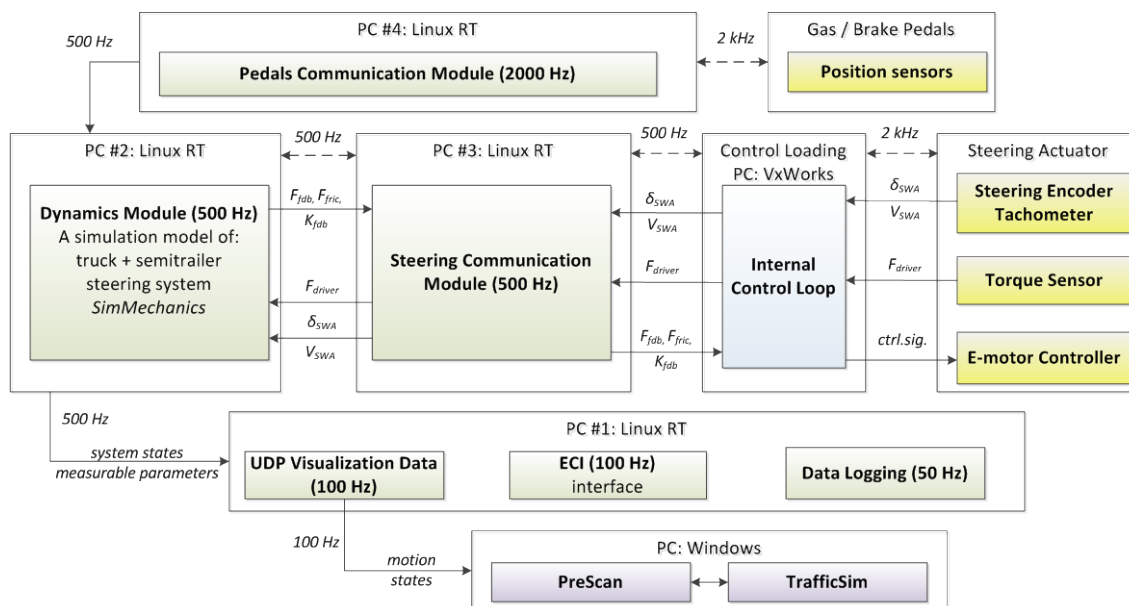

Figure 2. Principal scheme of a truck driving simulator

Steering models

Four steering models are considered (Figure 3):

A) A full non-linear multi-body model where friction on the input $T_{fric,sw}$, the hydraulic cylinder $T_{fric,HA}$ and the king-pin $T_{fric,KP}$ is considered. Furthermore, a reduced on-center stiffness k_{center} is used which represents a lower stiffness within a range of 1 deg of steering angle. The hydraulic assistance T_{PS} is generated as a result of the deflection of the torsion bar k_{tb} . The model includes kinematics of the pitman-arm and drag-link as well [Loo15]. The

validation of the steering model with a laboratory test setup is shown in Figure 4.

B) A simplified nonlinear model. The reduced on-centre stiffness k_{center} is omitted. The sector shaft has a rigid connection to pitman arm. The friction model is described by hyperbolic tangent function instead of the reset integrator friction model in model “A”;

C) A linear stiffness-damper model with a fixed ratio between steering wheel angle and king-pin angle;

D) Model “A” without power-steering assistance.

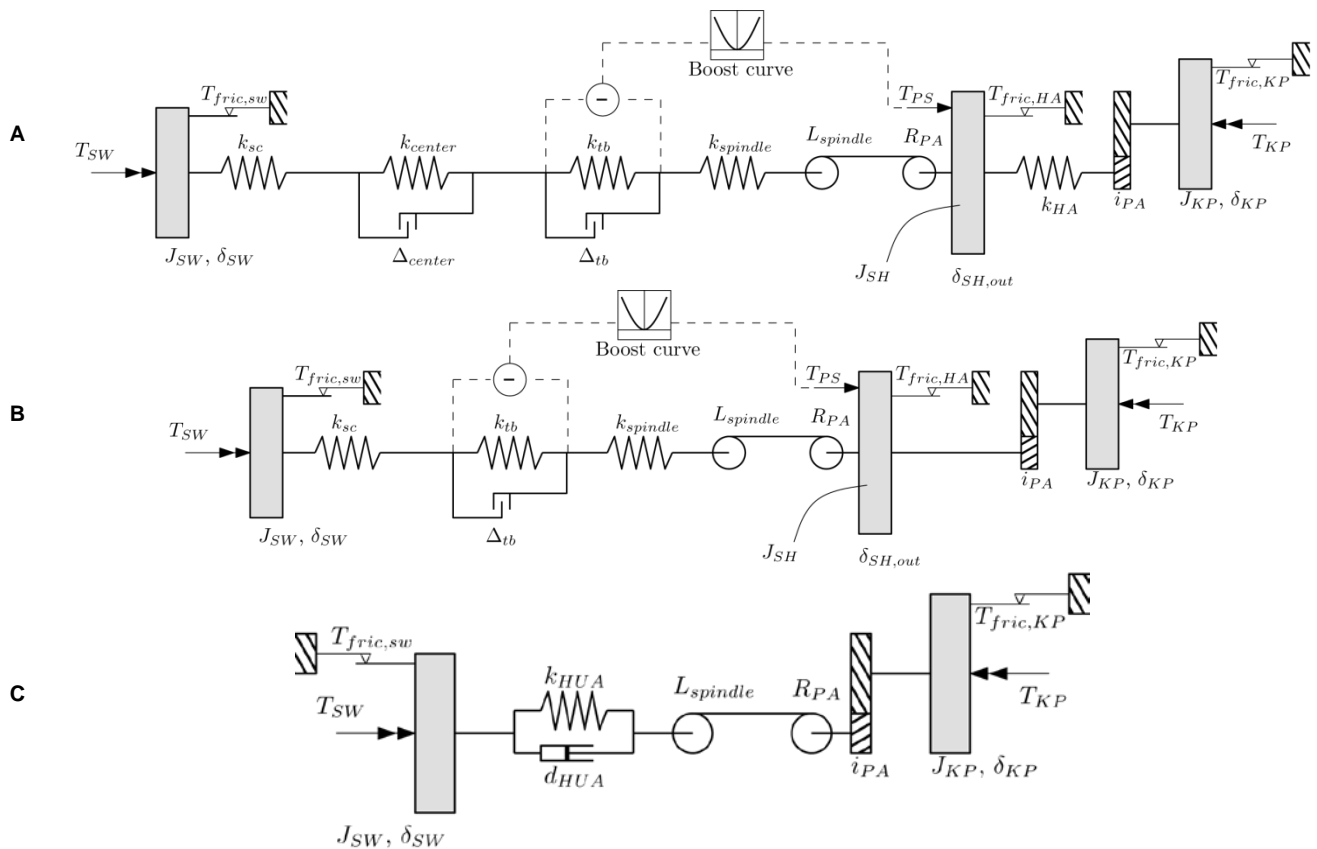

Figure 3. Steering models

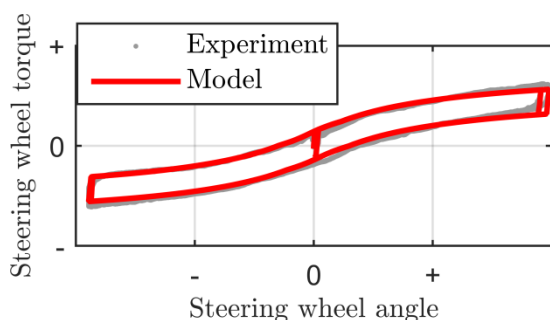

Figure 4. Validation of the steering model [Loo15] (No axis-labels due to confidentiality)

Test procedure

The test procedure includes pre-driving instructions and an intake questionnaire, a training session and 5-min driving of the simulator for each above-mentioned variant of steering model with and without disturbance. In total, 8 sessions were carried out by each participant in a randomised order. After each session, the drivers had a 5-min break and were asked to complete an evaluation form.

Training session

In order to get accustomed with the simulator, participants had to keep the vehicle within the lane and to change lane during a 3-min training session. The training session accustomed the drivers with the slower dynamics of commercial vehicles compared to passenger cars. The steering-system

model which the training session, was selected as the model for the last session in the driving task. The participants drove a scenario without any disturbance during the training session.

Driving task

The driving route was 7 km of highway road (A4) between Den Haag and Leiden. The road geometry was imported from the OpenStreetMap website to PreScan environment. The lane on this highway road has a width of 3.5 m, where truck width is 2.5 m.

The vehicle speed was 80 km/h and it is maintained during the session at this level using cruise control mode to concentrate a driver attention only on steering task.

The drivers task was to keep the vehicle within the third (right) lane during each driving session. The selected steering-system model was unknown for the participant. Each participant had a unique random sequence of the investigated steering-system models with and without disturbance.

A motion disturbance was generated as a stepwise cross wind with a wind speed of 90 km/h. To calculate the aerodynamic side force, the side areas were calculated from tractor and trailer geometry. Flow coefficients and aerodynamic drag centres were selected to achieve a similar lateral displacement under a stepwise wind disturbance according to [Wei04]. The cross wind can generate a lateral acceleration up to 1 m/s², which

corresponds to on-centre vehicle handling. An example of the applied stepwise wind disturbance is shown in Figure 5 including steering corrections

exerted by the driver. As can be observed, this driver has improved his performance after several repetitions.

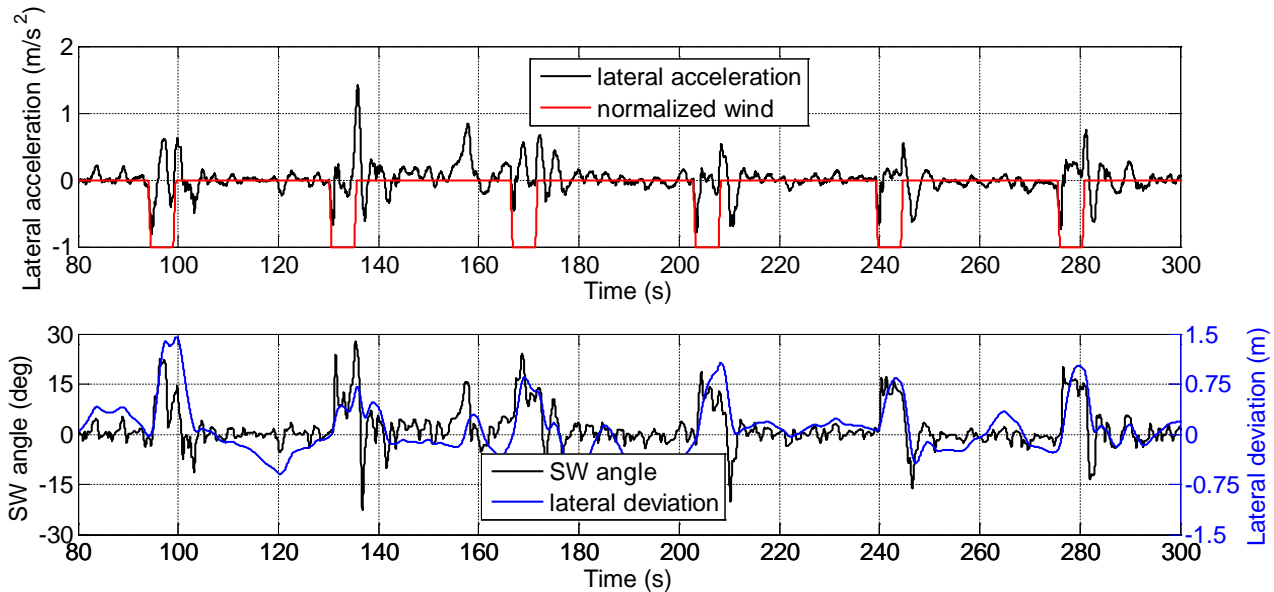

Figure 5. Example of participant's driving with wind disturbance

Data processing

Motion states and data from the steering actuator were collected and sampled at 50 Hz from the start of each session to the end of the driving route.

Objective indicators

In order to evaluate the driving performance, the following objective indicators are used:

- *SDSA*: standard deviation of steering wheel angle (deg) as an indicator of steering effort;
- *rmsST*: root-mean-square of steering torque (Nm) as an indicator of steering effort;
- *SDLP*: standard deviation of the lateral position (m) corresponding to truck as a lane keeping performance indicator;
- *SE*: steering entropy [Nak99] to assess driver workload based on SAE J2944, Appendix G;
- *SRR*: steering reversal rate (per minute) to assess driver workload based on SAE J2944, Appendix F;
- *SWS*: steering wheel steadiness (% of time) [Lee11] as an indicator of steering effort.

Subjective indicators

The subjective evaluation covers an assessment of steering feel and driver workload. The evaluation form is shown in Appendix A.

To assess the steering feel, the first part of the evaluation form includes a set of questions related to overall grade, steering effort, sense of solidity, smoothness, vehicle response and resistance. The form has been developed based on the investigations from [Pla85, Koi88, Rot13] for on-centre handling. The assessment is carried out via a 7-grade scale. The questions related to return ability are omitted, because the participants were instructed to always hold steering wheel (hands-on) during the driving task.

To assess driver workload, NASA TLX questionnaire [Har88] is used in the second part of the evaluation form. It covers 6 dimensions: mental demand, physical demand, temporal demand, performance, effort and frustration.

Results

Statistical significance of the results was assessed using an analysis of variance (ANOVA) comparing the three most relevant steering models A, B and C, and comparing model A to model D. Results were declared significant when p value is lower than 0.05. The subjective indicators were rank transformed before performing the analysis [Con81]. Objective indicators were computed for the driving route from 500 m until 6,5 km for each session.

No disturbance

The mean values of subjective and objective indicators, and their statistically significance (marked in bold) are in Table 1 and Table 2

correspondingly. The objective and subjective indicators are plotted using boxplots in Figure 6.

Table 1. Means, F and p values for subjective indicators without disturbance

Indicator	Type of steering model				Significance (A-B-C)	
	A	B	C	D	F	p
overall	4,6	5,4	6,0	2,4	3,43	0,047
effort	3,9	2,4	2,2	6,1	8,07	0,002
solidity	2,7	4,2	4,1	5,3	6,21	0,006
smoothness	4,2	2,7	2,3	5,2	7,57	0,002
response	3,8	2,9	3,1	5,2	1,53	0,235
resistance	4,1	3,1	3,0	5,4	1,79	0,186
workload	38,9	24,4	18,4	60,5	4,55	0,020

Table 2. Means, F and p values for objective indicators without disturbance

Indicator	Type of steering model				Significance (A-B-C)	
	A	B	C	D	F	p
SDSA	5,85	2,79	1,90	10,4	23,7	0,000
rmsST	2,17	0,85	0,80	9,36	49,5	0,000
SDLP	0,51	0,42	0,39	0,83	0,78	0,467
SE	0,62	0,60	0,59	0,64	4,14	0,027
SRR	19,4	17,4	13,5	17,7	1,44	0,255
SWS	22,8	43,7	50,9	10,5	7,36	0,003

The participants declared that the variant “D” without power assistance has the highest grade of effort and the lowest overall grade. The RMS steering torque is up to 76% higher compared to the cases with power assistance. Therefore, driver workload (NASA TLX) and steering entropy have the highest values as well. Regarding driving performance, SD of lateral position is up to 38,6% higher compared to with power assistance.

The difference between the models with power assistance is observed for all subjective and objective indicators and it is statistically significant except vehicle response and resistance. Statistical insignificance of these indicators can be explained by the participants having a low experience related to the dynamics of tractor with semitrailer.

The participants have graded the linear steering model as the best one and achieved the highest driving performance (SDLP of 0.39 m). Their effort was lower up to 67,5% of SD of steering angle and up to 63,1% of the RMS steering torque compared to a realistic steering behaviour.

The participants declared a difference between nonlinear and simplified steering models “A” and “B” from the point of effort, solidity, smoothness and overall grade. In the same time, the difference in driving performance (SD of lateral position) between these models was statistically insignificant.

Average grades of subjective indicators for simplified and linear steering models “B” and “C” are close to each other; and their difference is statistically insignificant after performing additional paired t-tests. Meanwhile, objective indicators, such as SD of steering angle and the RMS steering torque, have a statistically significant difference up

to 31,9% and 5,9% for models “B” and “C” correspondingly.

Stepwise cross wind disturbance

The results of the drivers’ questionnaire and the objective assessment are shown in Figure 7 via boxplots. The statistically significant results are (marked in bold) in Table 3 and Table 4.

Table 3. Means, F and p values for subjective indicators with disturbance

Indicator	Type of steering model				Significance (A-B-C)	
	A	B	C	D	F	p
overall	3,5	5,3	5,2	2,1	8,58	0,001
effort	4,0	2,9	2,9	6,4	2,88	0,033
solidity	3,4	4,0	4,1	5,6	1,32	0,284
smoothness	4,1	3,4	2,8	5,2	3,47	0,045
response	3,8	3,4	3,7	4,9	0,24	0,786
resistance	3,9	3,5	2,7	6,1	2,12	0,139
workload	46,1	32,4	32,0	66,5	3,06	0,043

Table 4. Means, F and p values for objective indicators with disturbance

Indicator	Type of steering model				Significance (A-B-C)	
	A	B	C	D	F	p
SDSA	9,16	6,56	5,04	13,6	40,1	0,000
rmsST	2,64	1,73	1,40	10,94	75,9	0,000
SDLP	0,61	0,52	0,52	1,02	0,64	0,535
SE	0,63	0,60	0,61	0,64	4,10	0,028
SRR	20,5	21,1	20,9	19,6	0,02	0,983
SWS	15,4	31,0	35,0	9,2	8,93	0,001

As can be expected, the driving without and with a stepwise cross wind disturbance has an effect on drivers’ grade and objective indicators. As an example for the variant “D”, SD of lateral position was increased up to 18,6% to 1,02 m and the driving required more steering corrections (SD of steering angle was increased up to 23,4%).

The participants declared the highest effort and workload to steer a tractor with semitrailer without power assistance “D”.

The difference between the models with power assistance is statistically significant for subjective indicators: overall grade, effort, smoothness and workload. The participants declared that steering with a nonlinear model “A” is more difficult compared to the other models with power assistance. The driving performance (SD of lateral position) between nonlinear model “A” and linear model “C” has a difference up to 14,8% and performed as statistically significant with p-value of 0.015 using additional paired t-test.

Similar to the motion without any disturbance, participants’ subjective grades for the simplified and linear steering models “B” and “C” are close to each other and statistically insignificant. In the same time, SD of steering angle and the RMS steering torque characterising steering effort, have a difference of 23,2% and 19,1% correspondingly.

Discussion

This study explored the effect of the complexity of a truck steering-system model on driver steering feel. We expected that the participants would be able to assess truck steering feel only up to a certain level of the complexity of steering model.

All participants declared a model without power assistance as the worst steering model due to high effort and workload. In the same time, they were able to finish a driving scenario and SD of lateral position was 1,02 m with a cross wind disturbance.

The statistically significant difference between the realistic nonlinear model "A" and other models ("B" and "C") was detected for subjective indicators as overall grade, effort, smoothness and workload. The difference between models "A" and "B" demonstrates that parameters such as reduced on-centre stiffness and stiffness of hydraulically actuated part play a significant role in the subjective assessment of truck steering feel.

The participants declared that driving with a simplified or linear steering model was more convenient compared to the realistic nonlinear model and they had a better driving performance. At the same time, there is no statistically significant difference between simplified and linear models for the motion without and with wind disturbance.

The main finding is that the level of the representation of steering model has a strong effect on the subjective assessment of truck steering feel after a certain level of steering model complexity.

The main limitation of the proposed study is the usage of a fixed-based simulator; therefore, the effect of cabin motion is only visualized. Meanwhile, steering torque feedback is perceived much sooner than physical motion, especially, for on-centre handling; therefore realistic steering feedback might partially compensate the lack of motion cues [All94].

Conclusion

The results of this investigation show that the detailed modelling of steering system plays a significant role in the subjective assessment of truck steering feel. These results can be used to select the complexity of steering model for subjective evaluation of steering feel. Future research will be oriented to investigate truck steering feel using a moving-based simulator and in lateral (merging) manoeuvres.

Acknowledgments

We would like to thank TASS International for their support and PreScan software. The research was supported by the Stichting voor de Technische Wetenschappen (Dutch Technology Foundation) STW.

References

- Allen R., Rosenthal T., **Meeting Important Cuing Requirements with Modest, Real-Time, Interactive Driving Simulations**, 1994, *SAE Technical Paper*, 940228
- Conover W., Iman R., **Rank transformations as a bridge between parametric and nonparametric statistics**, 1981, *American Statistician*, 35(3), pp. 124-129.
- Evers W., Besselink I., Nijmeijer H., **Development and validation of a modular simulation model for commercial vehicles**, *Int. J. of Heavy Vehicle Systems*, 2009, 16(1), pp. 132-153
- Haas S., **Ranking Tires for Heavy Truck Steering Feel Performance Using a Simulation Model**, 2006, *Tire Science and Technology*, 34(1), pp. 64-82.
- Hart S., Staveland L., **Development of NASA-TLX (Task Load Index): Results of empirical and theoretical research**, 1988, *Human Mental Workload*, pp. 139-183
- Koide M., Kawakami S., **Analysis of 'Steering Feel' Evaluation in Vehicles with Power Steering**, 1988, *JSAE Review*, 9(3), pp. 36-42
- Loof J., Besselink I., Nijmeijer H., **Component based modeling and validation of a steering system for a commercial vehicle**, *Int. Symposium on Dynamics of Vehicles on Road and Tracks*, 2015, (submitted)
- Nakayama O., Futami T., Nakamura T., Boer E., **Development of a steering entropy method for evaluating driver workload**, 1999, *SAE technical paper*, 1999-01-0892
- Plantan R., Rau J., Owens E., **Optimization of Power Steering Road Feel for Highway Tractors**, 1985, *SAE technical paper*, SAE852360
- Post T., **System Description & Specification ECoL 8000 Electric Control Loading System**, 2003
- Rothhämel M., Ijkema J., Drugge L., **On a method for generating a word pool for the description of steering feel**, 2010, *Proc. of the 10th Int. Symposium on Advanced Vehicle Control*.
- SAE J2944, **Operational Definitions of Driving Performance Measures and Statistics**, SAE International, Proposed Draft dated February 12, 2013
- Salaani M., Grygier P., Heydinger G., **Evaluation of heavy tractor-trailer model used in the National Advanced Driving Simulator**. 2003, *SAE technical paper*, 2003-01-1324.
- van Leeuwen P., de Groot S., Happee R., de Winter J. **Effects of concurrent continuous visual feedback on learning the lane keeping task**, 2011, *Proc. of the Sixth Int. Driving Symposium on Human Factors in Driver Assessment, Training and Vehicle Design*, pp. 482-488.
- van Paassen M., Stroosma O., Delatour J., **DUECA – data-driven activation in distributed real-time computation**, 2000, *AIAA Modeling and Simulation Technologies Conference*.
- Weinfurter H., **Controller Design by SIMPACK/SIMAT/ MATLAB: Disturbance Compensation by a Steer-by-Wire System in a MAN Truck**, 2004, SIMPACK User Meeting

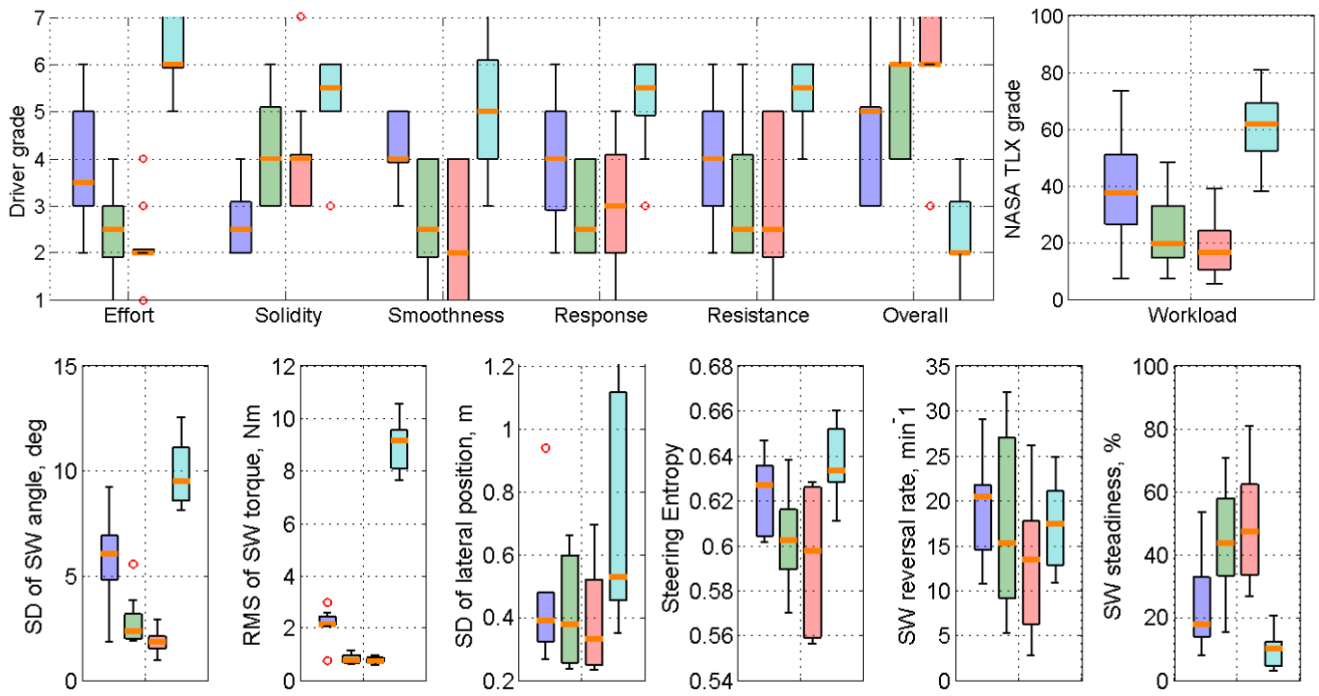

Figure 6. Objective and subjective indicators without any disturbance

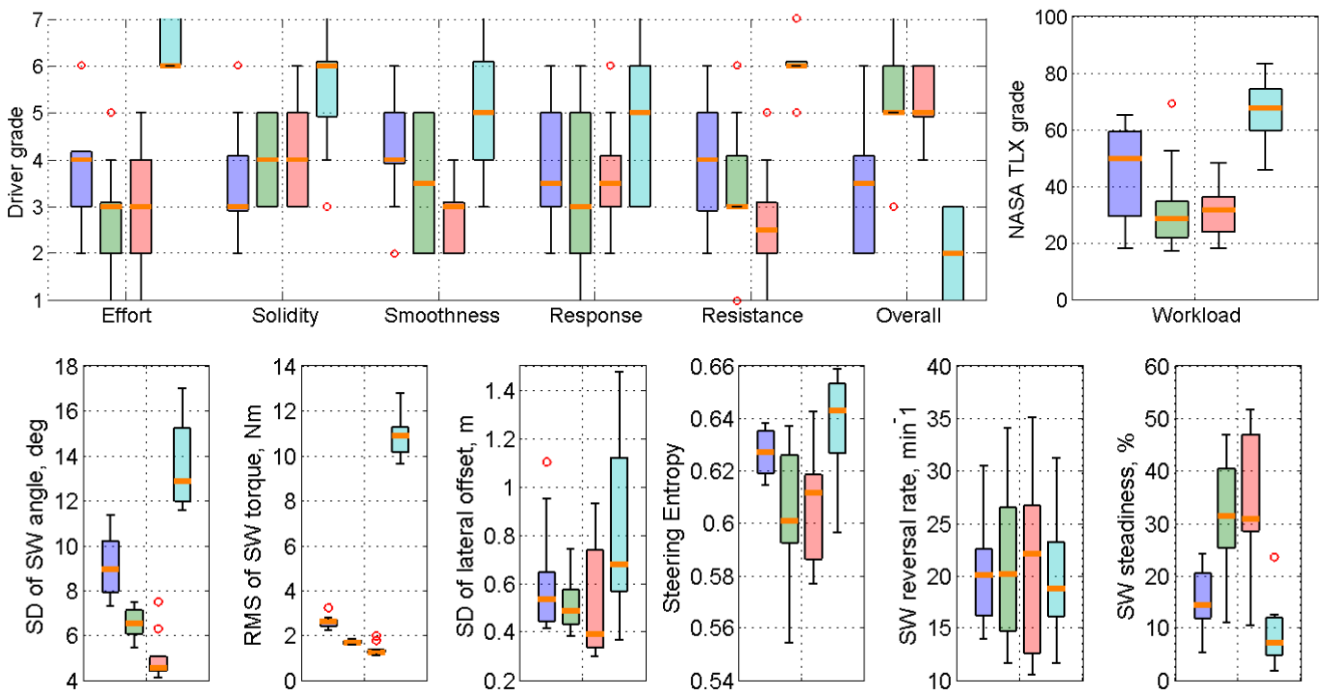

Figure 7. Objective and subjective indicators with cross wind disturbance



Append A – Driver Evaluation Form

Driver Name: _____ Male | Female Age: _____
 Driving experience _____ Truck driving experience _____
 How would you like to grade your driving skills: Incompetent 1| 2| 3| 4| 5| 6| 7 Expert

The questions below are about your experience in the run that you just performed. Put a cross on the line, not between them¹.

Evaluation of steering feel (returnability is omitted)

Extremely Very Slightly Normal Slightly Very Extremely

Grade scale

Overall Steering Feel Evaluation How was your overall feeling of the steering system?
 Poor _____ Excellent

Steering Effort How much effort was to steer a vehicle?
 Light _____ Heavy

Sense of solidity How solid was steering behaviour?
 Slack _____ Rigid

Smoothness How did proportionally steering torque change according to steering angle?
 Smooth _____ Sharp

Vehicle response How did vehicle reaction after steering input?
 Fast _____ Slow

Resistance How much resistance (friction) did you feel during a task?
 No Friction _____ Too Much Friction

Evaluation of driving task (NASA TLX)

Mental Demand How mentally demanding was the task?
 Very Low _____ Very High

Physical Demand How physically demanding was the task?
 Very Low _____ Very High

Temporal Demand How hurried or rushed was the pace of the task?
 Very Low _____ Very High

Performance How successful were you in accomplishing what you were asked to do?
 Perfect _____ Failure

Effort How hard did you have to work to accomplish your level of performance?
 Very Low _____ Very High

Frustration How insecure, discouraged, irritated, stressed, and annoyed were you?
 Very Low _____ Very High

¹ In the case that a participant puts the cross between the lines, the score of the line on the right-hand side should be taken.