

Bionic design methodology for wear reduction of bulk solids handling equipment

Chen, Guangming; Schott, Dingena L.; Lodewijks, G.

DOI

[10.1080/02726351.2016.1144666](https://doi.org/10.1080/02726351.2016.1144666)

Publication date

2016

Document Version

Final published version

Published in

Particulate Science and Technology: an international journal

Citation (APA)

Chen, G., Schott, D. L., & Lodewijks, G. (2016). Bionic design methodology for wear reduction of bulk solids handling equipment. *Particulate Science and Technology: an international journal*, 35 (2017)(5), 525-532. <https://doi.org/10.1080/02726351.2016.1144666>

Important note

To cite this publication, please use the final published version (if applicable). Please check the document version above.

Copyright

Other than for strictly personal use, it is not permitted to download, forward or distribute the text or part of it, without the consent of the author(s) and/or copyright holder(s), unless the work is under an open content license such as Creative Commons.

Takedown policy

Please contact us and provide details if you believe this document breaches copyrights. We will remove access to the work immediately and investigate your claim.

Bionic design methodology for wear reduction of bulk solids handling equipment

Guangming Chen, Dingena L. Schott, and Gabriel Lodewijks

Section Transport Engineering and Logistics, Delft University of Technology, Delft, The Netherlands

ABSTRACT

Large-scale handling of particulate solids can cause severe wear on bulk solids handling equipment surfaces. Wear reduces equipment life span and increases maintenance cost. Examples of traditional methods to reduce wear of bulk solids handling equipment include optimizing transport operations and utilizing resistant materials. To our knowledge, the so-called bionic design has not been utilized. Bionic design is the application of biological models, systems, or elements to modern engineering. Bionic design has promoted significant progress on the development of engineering products and systems. In order to use bionic design for wear reduction of bulk solids handling equipment surfaces, this paper introduces bionic design to bulk solids handling on the basis of analogies between biology and bulk solids handling. In addition, a bionic design methodology for the wear reduction of bulk solids handling equipment surfaces is formulated. Based on the bionic design methodology, two bionic models used for abrasive and erosive wear reduction of bulk solids handling equipment surfaces are proposed.

KEYWORDS

Bio-inspiration; biology to engineering; wear-resistant morphologies; worn by particles

1. Introduction

A bulk solids handling system is used to transport, transfer, transship, and store particulate solids such as iron ore and coal (Roberts 2006; Schulze 2008). Figure 1 shows two transfer points between belt conveyors of a belt conveying system. Due to the large-scale handling of particulate solids, the bulk solids handling equipment surfaces can suffer from severe wear. For instances, as shown in Figure 1(a), the loading chute surface suffers from abrasive wear, whereas in Figure 1(b), the discharging chute surface suffers from erosive wear (Roberts and Wiche 1993; Roberts 2003; Hilgraf 2007). Wear reduces the life cycle of equipment and causes extra maintenance cost. The wear of bulk solids handling equipment surfaces needs to be minimized to enable a sustainable expansion of bulk solids handling industry (Roberts and Wiche 1993; Roberts 2003; Hilgraf 2007).

The traditional methods to reduce wear of bulk solids handling equipment rely upon five aspects: (1) optimize transport operations using theoretical wear models (Roberts and Wiche 1993; Roberts 2003); (2) utilize wear-resistant materials with coating technologies (Hilgraf 2007); (3) supply a repulsive force to diminish the contact force between particulate solids and equipment (Schulze 2008); (4) add assistant components to utilize a self-wear mechanism by the transported bulk solids (Hilgraf 2007); (5) fabricate a surface geometry pattern based on empirical evidence (Schulze 2008; Hilgraf 2007). To our knowledge, bionic design has not been introduced to bulk solids handling.



Bionic design is an innovative methodology which utilizes biological characteristics to improve the abilities of modern engineering products or systems (Ball 1999; Vincent et al. 2006; Dai, Tong, and Ren 2006; Arvind 2008; Ren 2009). For example, by using the biological wear-resistant morphologies

from dung beetles, the wear-resistant ability of agricultural (Chirende and Li 2009) and drilling instruments (Gao et al. 2009) can be enhanced. Bulk solids handling (Roberts and Wiche 1993; Roberts 2003; Roberts 2006; Hilgraf 2007; Schulze 2008) has common properties with agricultural (Chirende and Li 2009) and drilling engineering (Ke et al. 2009). In order to use bionic design for the wear reduction of bulk solids handling equipment surfaces, the applicability of bionic design to bulk solids handling must be investigated.

In this paper bionic design is introduced to bulk solids handling and a bionic design methodology is formulated for the potential application of the wear reduction of bulk solids handling equipment surfaces. This paper is organized in the following way. Section 2 summarizes biological wear-resistant morphologies and wear-resistant mechanisms. Section 3 describes the bionic design models that utilize biological wear-resistant morphologies. A bionic design methodology to reduce the wear of bulk solids handling equipment surfaces is formulated in Section 4. Examples of using bionic design to reduce wear of bulk solids handling equipment are provided in Section 5, and conclusions are listed in Section 6.

2. Biological wear-resistant surfaces and wear-resistant mechanisms

As a result of evolution, biological organisms possess distinctive attributes for adapting to their natural environments (Ball 1999; Crofts and Summers 2011). These provide the sources of bio-inspirations for engineers to improve engineering designs (Altschuller 1999; Malshe et al. 2013; Niu et al. 2015). To utilize the biological wear-resistant abilities for the wear reduction of bulk solids handling equipment surface, this section summarizes the biological wear-resistant surfaces and

CONTACT Guangming Chen  G.Chen-1@tudelft.nl  Section Transport Engineering and Logistics, Delft University of Technology, The Netherlands. Color versions of one or more of the figures in the article can be found online at www.tandfonline.com/upst.

Published with license by Taylor & Francis, LLC © 2017 Guangming Chen, Dingena L. Schott, and Gabriel Lodewijks

This is an Open Access article distributed under the terms of the Creative Commons Attribution-NonCommercial-NoDerivatives License (<http://creativecommons.org/licenses/by-nc-nd/4.0/>), which permits non-commercial re-use, distribution, and reproduction in any medium, provided the original work is properly cited, and is not altered, transformed, or built upon in any way.

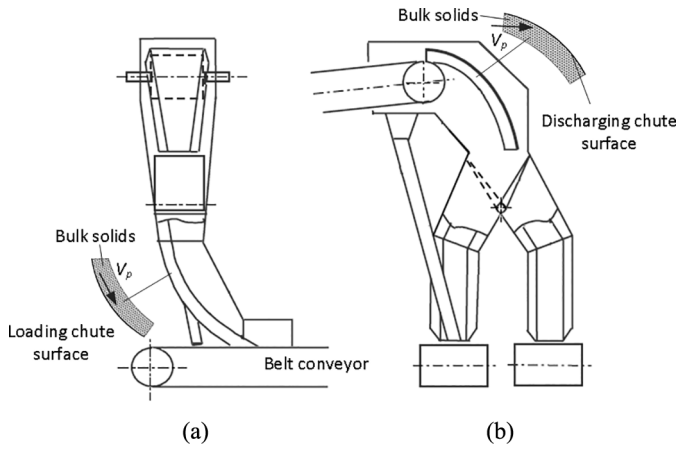

Figure 1. Wear of transfer points: (a) abrasive wear on loading chute surface, and (b) erosive wear on discharging chute surface (Roberts 2003).

their corresponding wear-resistant mechanisms from available literature (Ren et al. 1995; Tong et al. 2000; Ren et al. 2002; Baumgartner et al. 2007; Tong et al. 2007; Gao et al. 2008; Liu et al. 2008; Rong 2008; Rechenberg 2009; Tian et al. 2010; Zhang, Lu, and Li 2010; Han et al. 2012; Huang, Zhang, and Ren 2012; Zhang et al. 2013; Liu et al. 2015).

2.1 Biological wear-resistant surfaces

Biological wear-resistant surfaces are discovered from the living creatures that inhabit soil (Ren et al. 1995; Tong et al. 2000; Ren et al. 2002; Tong et al. 2007; Gao et al. 2008; Liu et al. 2008; Rong 2008; Zhang, Lu, and Li 2010) and sand environments (Baumgartner et al. 2007; Rechenberg 2009; Han et al. 2012; Huang, Zhang, and Ren 2012; Zhang et al. 2013). Figure 2 (a)–(f) shows six wear-resistant surfaces from five soil- or sand-living creatures. Figure 2(a)–(c) shows the head of dung beetle (Ren et al. 1995; Ren et al. 2002; Ren 2009), the back of ground beetle (Ren 2009), and a pangolin scale (Tong et al. 2000). These three surfaces have convex domes, concave pits, and corrugated ribs, respectively (Ren et al. 1995; Tong et al. 2000; Ren et al. 2002; Baumgartner et al. 2007; Tong et al. 2007; Gao et al. 2008; Liu et al. 2008; Rong 2008; Zhang, Lu, and Li 2010). Figure 2(d)–(e) shows two surface

morphologies of a Sahara sandfish (Rechenberg 2009). Figure 2(d) shows the morphology of the scales in the parallelogram on the dorsal body (Baumgartner et al. 2007). Figure 2(e) shows the morphology of the micro-ridges with nano-spikes in between. Figure 2(f) shows the back body surface of a desert scorpion, which has the morphology of intermediate grooves.

Unlike engineering product surfaces that interact with the particulate solids, these biological wear-resistant surfaces have non-smooth morphologies with a variety of discrete elements (Dai, Tong, and Ren 2006; Arvind 2008; Ren 2009). These non-smooth surface morphologies form various biological structures which have an important impact on their wear-resistant abilities (Vincent et al. 2006; Tian et al. 2010; Zhang, Lu, and Li 2010). The biological morphologies operate using sizes ranging from nanometers to millimeters, as seen in Figure 2. The considered size ranges are much bigger in engineering domains. In order to incorporate the wear-resistant morphologies to engineering applications, the underlying wear-resistant mechanisms corresponding to the non-smooth biological morphologies must be understood (Ball 1999; Hardie 2011).

2.2 Wear-resistant mechanisms

Based on the wear characteristics of biological surfaces, the particulate soil or sand solids, and the wear conditions, the wear-resistant mechanisms are revealed in relation to the non-smooth biological morphologies. This occurs in respect of abrasive wear reduction and erosive wear reduction (Rechenberg 2009; Han et al. 2012; Huang, Zhang, and Ren 2012; Zhang et al. 2013). Table 1 summarizes the abrasive wear and erosive wear-resistant mechanisms in accordance with the biological surfaces and their biological morphologies.

3. Analysis of bionic models for wear reduction

A bionic model can be designed by mimicking an existing natural object. One can also use the natural model as bio-inspiration to create a desired model. The basis of biological wear-resistant morphologies and the wear-resistant mechanisms is summarized in Table 1. Bionic models for abrasive wear reduction (Ren et al. 1995; Ren et al. 2002; Gao et al. 2008; Rong 2008) and erosive wear reduction (Rechenberg

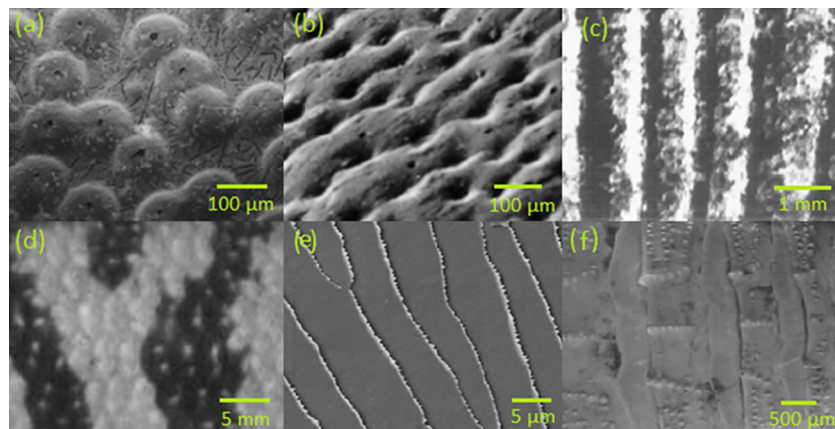

Figure 2. Biological wear-resistant surface morphologies: (a) convex domes from a dung beetle (Luquan Ren 2009); (b) concave pits from a ground beetle (Luquan Ren 2009); (c) corrugated ribs from a pangolin scale (Tong et al. 2007); (d) sandfish scales in parallelogram (Baumgartner et al. 2007) (e) micro-ridges from a sandfish scale (Baumgartner et al. 2007); and (f) intermediate grooves from a desert scorpion (Zhang et al. 2013).

Table 1. Characterization of biological surfaces, biological morphologies, and wear-resistant mechanisms.

	Biological surfaces	Biological morphologies	Wear-resistant mechanisms
Abrasive wear reduction	Head of dung beetle	Convex domes	Reduce soil resistance (Ren et al. 1995, 2002)
	Back of ground beetle	Concave pits	Prevent stress propagation (Ball 1999; Gao et al. 2008)
	Pangolin scale	Corrugated ribs	Generate guiding and rolling effects (Tong et al. 2007)
	Dorsal scales of sandfish	Scales in parallelogram	Provide friction anisotropy (Baumgartner et al. 2007)
Erosive wear reduction	Dorsal scale of sandfish	Ridges	Decompose particle flow (Rechenberg 2009)
	Dorsal scale of sandfish	Spikes	Reduce contact friction (Rechenberg 2009)
	Back of desert scorpion	Grooves	Reduce oblique impact pressure (Han et al. 2012)

2009; Han et al. 2012; Zhang et al. 2013) have been proposed and were tested under certain experimental conditions. To review the bionic models, the following three aspects are analyzed: bionic surface, particulate solids, and wear conditions.

3.1 Abrasive wear reduction

Two examples of bionic models using biological morphologies for abrasive wear reduction are bionic bulldozing plates and the bionic rib model, which are designed respectively based on the convex domes morphology (Ren et al. 1995; Ren et al. 2002) and the corrugated rib morphology (Tong et al. 2000; Tong et al. 2007; Rong 2008). These two morphologies are summarized in Table 1.

A bionic bulldozing model is shown in Figure 3. To demonstrate the soil resistance reduction of bionic bulldozing plates, experimental tests were carried out with 22 bionic bulldozing plates based on an optimal design method of D-optimum theory (Ren et al. 1995). For comparisons of the measured soil resistance, a conventional (smooth) plate was prepared. The experiments showed that on an average the soil resistance acting on bionic bulldozing plates was reduced by 13.02%. Furthermore, it was calculated that a bionic plate of a parallelogram arrangement can reduce soil resistance up to 18.09%. The convex domes for the most optimal plate are 7 mm in height and 25 mm in base diameter. The reason for soil resistance reduction is that the convex domes break the continuous forces between soil material and the surface of bulldozing plates, reducing abrasive wear. In the experimental tests, the following bionic surface, particulate solids, and wear conditions were used:

- Bionic surface: Two kinds of rectangle and parallelogram arrangements for using convex domes were designed, which are shown in Figure 3(a). Based on the ratio of the area occupied by convex domes to the total area of 45%,

the height and the base diameter of convex dome are respectively 2–8 and 16–32 mm. The number of convex domes is in the range of 20–50. The sizes of the matrix of all bulldozing plates are 400 mm in length and 200 mm in width. All bulldozing plates are made of plain carbon steel.

- Particulate solids: A clay soil with an average moisture content of 27.8% (dry basis) was used. The particle size distribution of the used soil is shown in Table 2.
- Wear conditions: The soil-engaging tests were proceeded in an indoor soil bin as shown in Figure 3(b). The soil resistance was measured using an SR-30C data recorder (Ren et al. 1995). During the 22 groups of experimental tests, the wear parameters of the cut angle, cut depth, forward speed, and soil particle size distribution remained constant.

A bionic rib model is shown in Figure 4 (Rong 2008). An experimental study of an abrasive wear test of the bionic rib models was performed. The results showed that in general bionic models with rib distances (L) less than 30 mm promote a lower wear rate in comparison with the conventional smooth surface. Using the D-optimum design theory (Rong 2008), the minimal wear rate is obtained at the conditions of using abrasive material sizes of 0.104–0.214 mm, sliding velocity of 1.68 m/s, and rib distance of 15.71 mm. The reason for the abrasive wear reduction is that the movements of particles are guided when the particle sliding direction is parallel with the corrugated ribs, while the rolling motions of particles are enhanced when the particle sliding directions are perpendicular to the ribs. Furthermore, it was found that the wear rate corresponding to the parallel case is lower than that of the perpendicular case (Tong et al. 2000; Tong et al. 2007). In these experiments, the bionic surface, particulate solids, and wear conditions were:

- Bionic surface: Three bionic rib surfaces were designed as shown in Figure 4(b) based on the geometrical model of corrugated ribs, as shown in Figure 4(a). The material used

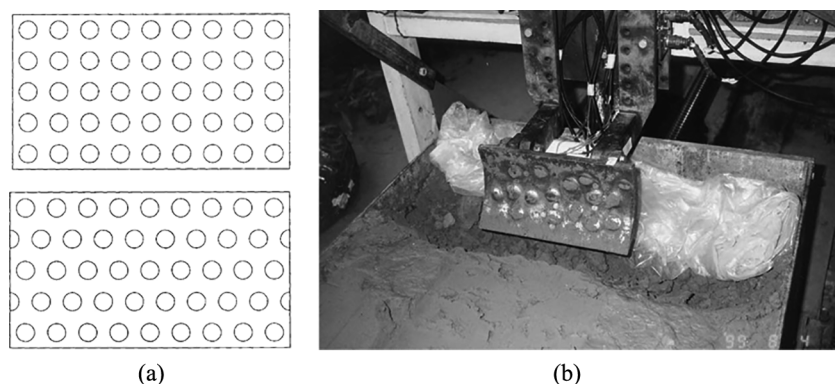

Figure 3. Application of convex domes on a bulldozing plate: (a) geometrical model (Ren et al. 1995) and (b) bionic model (Ren et al. 2002).

Table 2. Particle size distribution of the used soil (Ren et al. 1995).

Size (mm)	>0.05	0.05–0.01	0.01–0.005	<0.001
% wt	20.94	18.18	7.91	37.16

for manufacturing worn samples was plain carbon steel. The rib intervals of the three samples were 15.71, 12.56, and 9.42 mm, respectively.

- **Particulate solids:** The abrasive material contained 96.5 wt% quartz sand and 3.5 wt% bentonite. The average size of bentonite was approximately 0.075 mm. The water content was between 3 and 5 wt%. Three levels of abrasive material size were used: 0.104–0.214, 0.214–0.420, and 0.420–0.840 mm. These materials are shown in Figure 5(a)–(c).
- **Wear conditions:** The tests were carried out on an abrasive wear tester shown in Figure 6. In the experiments, bionic models were fixed on the holders and a full sliding distance of 820 m was used. After half of the sliding distance, 50% of the abrasive material was replaced with fresh abrasive material. The submerging depth of the specimen was 70 mm. The impingement angle of the abrasive materials against specimen varied between 33° and 37°. Three relative sliding velocities were tested: 1.68, 2.35, and 3.02 m/s.

The above two bionic models demonstrate that non-smooth biological morphologies can be used to reduce abrasive wear. However, the biological morphologies can be worn off during the work process. In order to sustain the non-smooth morphologies, the “self-healing” characteristic of biological surface (Gao et al. 2008) was introduced. Based on this characteristic, the bionic drill bit was invented (Altshuller 1999; Gao et al. 2008).

3.2 Erosive wear reduction

The bionic models that utilize biological morphologies for erosive wear reduction are the bionic ridge surface and the bionic groove surface, which are designed respectively based on the ridge morphology (Baumgartner et al. 2007;

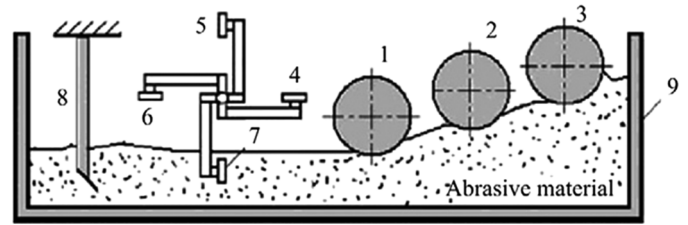
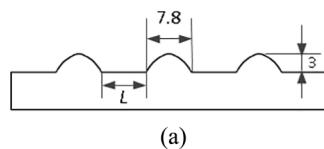

Figure 6. Schematic illustration of abrasive wear tester (1–3: compacting wheels; 4–7: bionic models; 8: assistant mixer; 9: rotary container) (Rong 2008).

Rechenberg 2009) and the intermediate groove morphology (Han et al. 2012; Zhang et al. 2013). These two morphologies are also summarized in Table 1.

A bionic ridge model is shown in Figure 7(a). To verify the erosive wear characteristics of the bionic ridge surface, an area of conventional flat surface was prepared for comparison. The experimental results showed that the eroding material of sand grains maintained continuous flow motion on the bionic ridge surface area. However, the sand grains suspended on the conventional flat surface, which indicates that the ridge surface enables the continuous flow of particulate solids. Therefore, ridges can decompose the cutting force of the flow of eroding particles, resulting in less erosive wear on the bionic ridge surface than the flat surface (Rechenberg 2009). In their experiment, the bionic surface, particulate solids, and wear conditions were:

- **Bionic surface:** Figure 7(a) shows the scanning electron microscopy (SEM) image of the bionic micro-ridge surface. Epoxy polyoxymethylene was used to fabricate an area of 10 mm × 10 mm with the uniform morphology of inverse “V” ridges. Figure 7(b) presents particle flow characteristics with respect to the bionic ridge surface and the conventional flat surface.
- **Particulate solids:** The abrasive material used to erode the bionic specimen was sand grains as shown in Figure 7(b).



(a)



(b)

Figure 4. Application of bionic design for wear reduction: (a) geometrical model and (b) bionic model (Rong 2008).

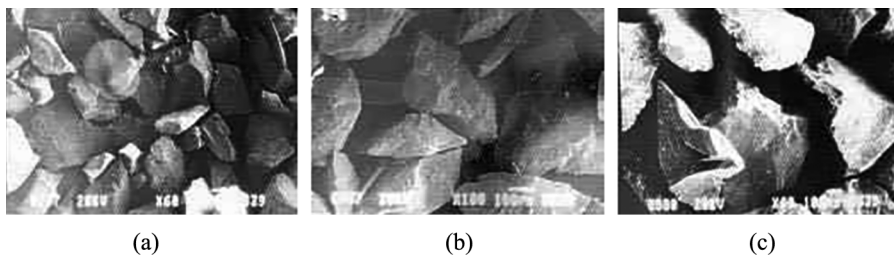

(a)

(b)

(c)

Figure 5. Abrasive material sizes used in the abrasive tests: (a) 0.104–0.214 mm; (b) 0.214–0.420 mm; and (c) 0.420–0.840 mm (Rong 2008).

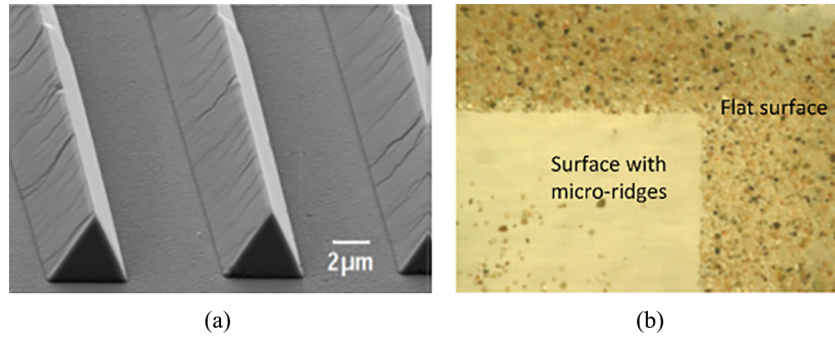

Figure 7. Application of ridge morphology: (a) bionic model and (b) comparison between bionic ridge surface and a flat surface (Rechenberg 2009).

These sand grains have an average particle size of 0.25 mm and were collected from the Sahara desert.

- **Wear condition:** A sandblasting cannula was used to continuously supply sand grains. The sand grains fell onto the inclined tested surface and flew over both the fabricated bionic ridge surface and the non-treated flat surface. The sliding characteristics of the sand grains on the bionic surface were closely observed by a digital microscope (Rechenberg 2009).

A bionic groove model is shown in Figure 8 (Han et al. 2012). To verify its erosive wear reduction ability, simulations that were based on computational fluid dynamics (CFD) were performed, and it was demonstrated that the contact pressure for low particle impinging angles was significantly reduced due to the disturbances from grooves (Han et al. 2012; Zhang et al. 2013). Experimental scheme based on D-optimum theory was designed to investigate the significance of geometrical parameters (groove height (H), groove distance (D), and groove width (W)) on wear rate and to obtain the optimal bionic model (Han et al. 2012). These experiments were conducted at an impact angle of 30° and using the eroding material of silica sand of $150\ \mu\text{m}$ particle size. The experimental results showed that the significance of the geometrical parameters

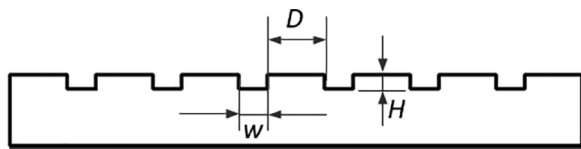

Figure 8. Geometrical model of a bionic groove surface (Han et al. 2012).

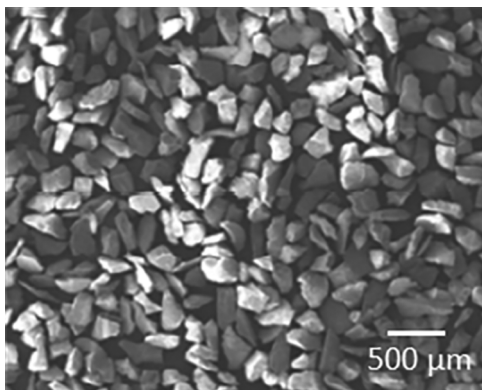

Figure 9. Eroding material of silica sands (Zhang et al. 2013).

was as follows: groove distance (D), groove width (W), and groove height (H). The lowest erosion rate was found at the combination of groove distance $D=2\ \text{mm}$, groove width $W=5\ \text{mm}$, and groove height $H=4\ \text{mm}$. The bionic surface, particulate solids, and wear conditions were:

- **Bionic surface:** The dimensions of the rectangular matrix of the bionic surfaces (Figure 8) were $50\ \text{mm} \times 50\ \text{mm} \times 5\ \text{mm}$. The groove height (H) and the groove distance (D) were both in the range of 2–4 mm, and the groove width (W) was in the range of 3–4 mm. The bionic specimen was made of mild steel.
- **Particulate solids:** the eroding material of dry silica sands is shown in Figure 9, which had an average particle diameter equal to $150\ \mu\text{m}$ (Han et al. 2012).
- **Wear conditions:** The used erosion test rig is schematically illustrated in Figure 10. Preliminary experiments indicated the weight loss of bionic samples stabilized after 10–15 min. Therefore, the sample was initially eroded for 15 min for each test, after which wear loss was measured for 5-min test period at an accuracy of $\pm 0.01\ \text{mg}$ using an electronic balance. The pressure of the air compressor was 0.5 MPa. Through all tests, the eroding material of silica sand and the eroding material injection angle remained constant.

The above two bionic models illustrate that non-smooth biological morphologies are also applicable for erosive wear reduction. For enhancing the erosive wear-resistant ability of the bionic models, the surface materials can be modified based on the surface material information of desert creatures (Altschuler 1999). The bionic models that adopt the biological material information for erosive wear reduction can be found in Han et al. (2012), Huang, Zhang, and Ren (2012), and Zhang et al. (2013).

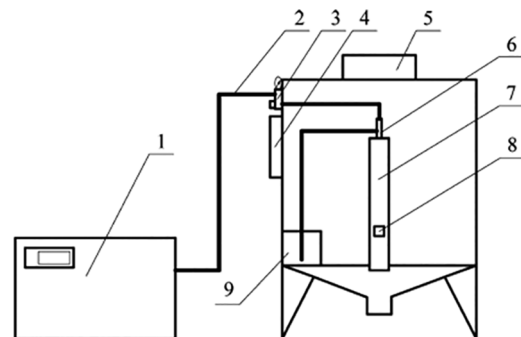

Figure 10. Schematic illustration of erosion test rig: 1, air compressor; 2, air pipe; 3, pressure control valve; 4, control box; 5, dust collector; 6, blast gun; 7, nozzle; 8, sample holder; 9, particle container (Han et al. 2012).

4. Bionic design for wear reduction in bulk solids handling

This section presents the three aspects of the worn surface, the particulate solids, and the wear condition for biology, agricultural engineering, drilling engineering, and bulk solids handling to transfer the biological abilities from biology to bulk solids handling. Moreover, this section formulates a bionic design methodology to be used in bulk solids handling.

4.1 Wear aspects in bulk solids handling

Identifying the analogies of the three wear aspects of worn surface, particulate solids, and wear condition in biology and engineering is a prerequisite for formulating a bionic design methodology (Dai, Tong, and Ren 2006; Arvind 2008; Ren 2009). On the basis of general cases, Table 3 compares the three wear aspects from biology to agricultural engineering, drilling engineering, and bulk solids handling.

Table 3 shows that both biology and bulk solids handling deal with dry and moist particulate solids under similar wear conditions of high speed and high pressure. Through the combination of the similarities from agricultural engineering and drilling engineering to bulk solids handling, and the fact that some agricultural and drilling engineering applications already adopt bionic design, a potential applicability of bionic design for wear reduction of bulk solids handling equipment surfaces is demonstrated.

4.2 Bionic design methodology in bulk solids handling

Nine systematic bionic design methodologies were found in Vincent et al. (2006), Torben (2009), Nagel et al. (2010), Versos (2011), and Kore, Sakri, and Karadi (2014), all of which have either explicitly or implicitly incorporated the bionic design principle of biological function analysis. However, only the bionic design methodology in Kore, Sakri, and Karadi (2014) is based on structural bionics. This study shows the direct relation for the application of mechanical products. Hence, these methodologies must be more specific in order to use biological morphologies for the wear reduction of bulk solids handling equipment surfaces. Therefore, on the basis of the bionic design methodology in Kore, Sakri, and Karadi (2014), we incorporate the bionic design principles such as biological scale analysis from Nagel et al. (2010) and implementation of TRIZ from Vincent et al. (2006), as well



Figure 11. Bionic design methodology for wear reduction in bulk solids handling.

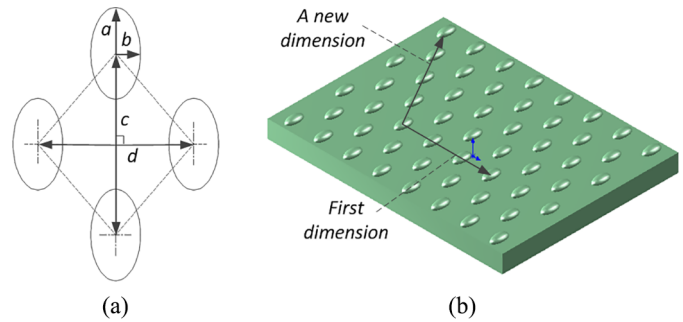

Figure 12. Bionic design for abrasive wear reduction: (a) geometrical model and (b) bionic model.

as an optimal design method of D-optimum theory (Ren et al. 1995; Ren et al. 2002). A bionic design methodology for wear reduction of bulk solids handling equipment surface is formulated, consisting of five steps:

- Step (1) Search for bio-inspirations in biology where biological systems are confronted with similar or opposite situations. One can also refer to the available textbook for biological functions (Torben 2009; Nagel et al. 2010).
- Step (2) Analyze biological function mechanisms from the biological scale to the engineering scale (Yu and Wang 2012; Hsu et al. 2014).
- Step (3) Design bionic models based on biological function mechanisms (Ren and Liang 2010) and/or using the inventive principles of TRIZ (Altshuller 1999; Ju et al. 2002; Vincent et al. 2005; Bonser and Vincent 2007).
- Step (4) Evaluate the bionic models to discover the optimal one which has the best wear-resistant ability (Hu 2009; Chandel, Singh, and Seshadri 2012). For experimental scheme design, D-optimum theory is suggested (Ren et al. 1995; Ren et al. 2002).
- Step (5) Apply the optimized bionic model that fits for the engineering conditions to bulk solids handling equipment surfaces.

This bionic design methodology is briefly illustrated in Figure 11.

Table 3. Wear comparisons between biology and three engineering environments.

	Worn surface	Particulate solids	Wear condition
Biology	Non-smooth: e.g., convex domes and concaves (Ren 2009); sizes of nanometers to millimeters (Dai, Tong, and Ren 2006; Arvind 2008; Ren 2009)	Dry and moist solids; fines and lumps: e.g., soil (Ren 2009) and rock (Hardie 2011)	Biological organisms actively (Ren 2009) interact with solids; can also passively (Han et al. 2012); low and high speeds (Han et al. 2012) and low pressure
Agricultural engineering	Mostly smooth or flat metals (Ren 2009); size scale in meters	Moist or semi-viscous soil (Ren 2009; Chirende and Li 2009)	Instruments actively interact with solids; low speed and low pressure (Chirende and Li 2009)
Drilling engineering	Mostly smooth or flat metal (Gao et al. 2009); size scale in meters	Hard rock particles or strata (Gao et al. 2009)	Instruments actively interact with solids; high speed and high pressure (Gao et al. 2009)
Bulk solids handling	Mostly smooth or flat metal (Roberts and Wiche 1993; Roberts 2006; Schulze 2008); size scale in meters	Dense dry or moist solids; fines and lumps: e.g., iron ore (Miszewski et al. 2012)	Equipment actively interact with solids; can also passively; high speed; low and high pressure (Schulze 2008)

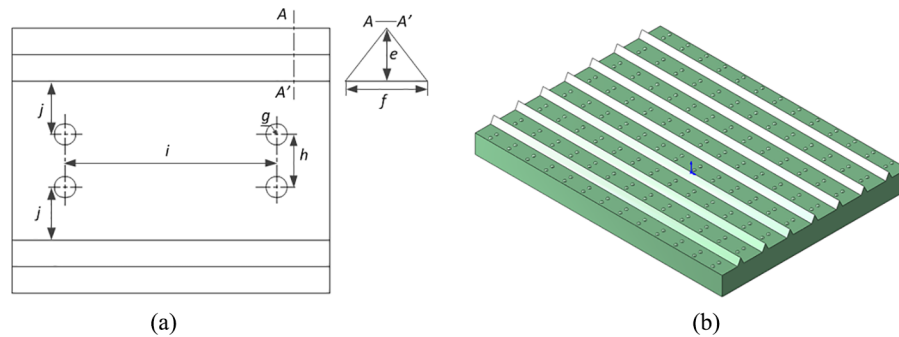

Figure 13. Bionic design for erosive wear reduction: (a) geometrical model and (b) bionic model.

5. Wear reduction of bulk solids handling equipment

Two wear scenarios of a loading chute and a discharging chute are shown in Figure 1(a)–(b). Following the bionic design methodology in Section 4.2, a bionic design for both abrasive and erosive wear reduction is conducted in the following ways:

Step (1) Preliminarily sources of bio-inspirations can be obtained from the biological abrasive and the erosive wear-resistant phenomena summarized in Table 1.

Step (2) The biological function mechanisms corresponding to the biological wear-resistant phenomena are also presented in Table 1. These biological functions are applicable at engineering scales based on the applications of bionic models in Section 3.

Step (3) To design a bionic model for abrasive wear reduction, the guiding effect for particle motions from the corrugated ribs (summarized in Table 1) can be enhanced by creating a new dimension based on the principle of “Transition into a new dimension” of TRIZ (Altshuller 1999). Hence the geometrical design of half ellipsoids (similar to corrugated ribs) in parallelogram arrangement is proposed as the bionic model for abrasive wear reduction, shown in Figure 12(a)–(b), where a , b , c , and d are geometrical parameters.

For achieving erosive wear reduction, the function mechanisms discovered from the microstructure of the dorsal scale on sandfish (in Table 1) are used, where the spikes can reduce contact friction and the inverse “V” ridges disperse cutting force to prevent the contact force on spikes from reaching failure criteria (Rechenberg 2009). Therefore, the bionic model of domes (similar to spikes) distributed between inverse “V” ridges is proposed for erosive wear reduction, shown in Figure 13(a)–(b), where e , f , g , h , i , and j are geometrical parameters.

Step (4) To evaluate the bionic models with respect to wear reduction, experimental tests which quantify wear rate can be carried out. Since the wear parameters for geometrical model, particulate solids, and wear conditions must be accounted for (Roberts and Wiche 1993), D-optimum theory is applied to reduce the number of experimental tests while still finding the optimal model. On the other hand, the numerical simulations based on discrete element method (DEM) can be used to predict wear (Mezhericher, Brosh, and Levy 2011; Powell et al. 2011).

Step (5) The bionic model which has lowest wear rate under practical handling conditions found in the previous step

can be applied to the bulk solids handling equipment surface.

6. Conclusions

This paper introduces bionic design to bulk solids handling equipment for the potential application of wear reduction of bulk solids handling equipment. The following conclusions were drawn:

- The biological morphologies from biological wear-resistant surfaces have an important effect on wear reduction. The biological morphologies are categorized as abrasive wear-resistant morphologies and erosive wear-resistant morphologies based on wear characteristics.
- The available bionic models were analyzed with respect to bionic surface, particulate solids, and wear conditions, which showed that the bionic design of using biological wear-resistant morphologies is applicable for the wear reduction of the engineering product surfaces.
- The analogies of wear aspects between biology and bulk materials handling indicate significant potential for using bionic design for the wear reduction of bulk solids handling equipment surfaces. Moreover, a bionic design methodology for the wear reduction of bulk material handling equipment is formulated.
- Using the proposed bionic design methodology, the procedures for wear reduction of bulk solids handling equipment surfaces are illustrated, and two possible bionic models respectively for abrasive and erosive wear reduction are proposed.

This paper focuses on abrasive wear and erosive wear reduction respectively for the loading chute and discharging chute of a belt conveying system, as shown in Figure 1; currently DEM simulations to predict wear loss of the proposed two bionic models are being carried out.

Funding

The authors are grateful for the funding from the China Scholarship Council (No. 201206170158).

References

- Altshuller, G. S. 1999. The innovation algorithm: TRIZ, systematic innovation and technical creativity. In L. Shulyak and S. Rodman. Worcester, MA: Technical Innovation Center, INC.

- Arvind, R. 2008. Biomimetics in tribology: recent developments. *Journal of the Korean Physical Society* 52 (3):656–68. doi:10.3938/jkps.52.656.
- Ball, P. 1999. Shark skin and other solutions. *Nature: Engineering* 400 (6744):507–508.
- Baumgartner, W., F. Saxe, A. Weth, D. Hajas, D. Sigumonrong, J. Emmerlich, M. Singheiser, W. Bohme, and J. M. Schneider. 2007. The Sandfish's skin: Morphology, chemistry and reconstruction. *Journal of Bionic Engineering* 4:1–9. doi:10.1016/s1672-6529(07)60006-7.
- Bonsler, R. H. C., and J. F. V. Vincent. 2007. Technology trajectories, innovation, and the growth of biomimetics. *Proceedings of the Institution of Mechanical Engineers, Part C: Journal of Mechanical Engineering Science* 221 (10):1177–80. doi:10.1243/09544062jmms522.
- Chandel, S., S. N. Singh, and V. Seshadri. 2012. Experimental study of erosion wear in a centrifugal slurry pump using coriolis wear test rig. *Particulate Science and Technology* 30 (2):179–95. doi:10.1080/02726351.2010.523926.
- Chirende, B., and J. Li. 2009. Review on application of biomimetics in the design of agricultural implements. *Biotechnology and Molecular Biology Reviews* 4 (2):042–048.
- Coelho, D. A., and C. A. M. Versos. 2011. A comparative analysis of six bionic design methods. *International Journal of Design Engineering* 4(2):114–31. doi:10.1504/ijde.2011.045131.
- Crofts, S. B., and A. P. Summers. 2011. Swimming in the Sahara. *Nature: Biomechanics* 472:177–78. doi:10.1038/472177a.
- Dai, Z., J. Tong, and L. Ren. 2006. Researches and developments of biomimetics in tribology. *Chinese Science Bulletin* 51 (22):2681–89. doi:10.1007/s11434-006-2184-z.
- Gao, K., Y. Sun, R. Gao, L. Xu, C. Wang, and Y. Li. 2009. Application and prospect of bionic non-smooth theory in drilling engineering. *Petroleum Exploration and Development* 36 (4). Research Institute of Petroleum Exploration & Development, PetroChina:519–22, 541.
- Gao, K., Y. Sun, L. Ren, P. Cao, W. Li, and H. Fan. 2008. Design and analysis of ternary coupling bionic bits. *Journal of Bionic Engineering* 5:53–59. doi:10.1016/s1672-6529(08)60072-4.
- Han, Z., J. Zhang, C. Ge, W. Li, and L. Ren. 2012. Erosion resistance of bionic functional surfaces inspired from desert scorpions. *Langmuir: The ACS Journal of Surfaces and Colloids* 28 (5):2914–21. doi:10.1021/la203942r.
- Hilgraf, P. 2007. Wear in bulk materials handling. *Bulk Solids Handling* 27 (7):464–77.
- Hsu, S. M., Y. Jing, D. Hua, and H. Zhang. 2014. Friction reduction using discrete surface textures: Principle and design. *Journal of Physics D: Applied Physics* 47 (33):335307. doi:10.1088/0022-3727/47/33/335307.
- Hu, Y. 2009. Tribology research in China: A personal view. *Proceedings of the Institution of Mechanical Engineers, Part J: Journal of Engineering Tribology* 223 (1):1–15. doi:10.1243/13506501jet469.
- Huang, H., Y. Zhang, and L. Ren. 2012. Particle erosion resistance of bionic samples inspired from skin structure of desert lizard, *Laudakin Stoliczka*. *Journal of Bionic Engineering* 9 (4):465–69. doi:10.1016/s1672-6529(11)60141-8.
- Kore, S. G., M. I. Sakri, and L. N. Karadi. 2014. Design and analysis of machine learning experiments. *International Journal of Mechanical Engineering and Robotics Research* 3 (3):731–37.
- Liu, G., J. Li, X. Tian, M. Zou, and Y. Li. 2008. Experiment on reduction of soil adhesion force and sliding resistance of earthworm non-smooth surface. *Nongye Jixie Xuebao/Transactions of the Chinese Society of Agricultural Machinery* 39 (9):138–43.
- Liu, Z., W. Yin, D. Tao, and Y. Tian. 2015. A glimpse of superb tribological designs in nature. *Biotribology* 1–2:11–23. doi:10.1016/j.biotri.2015.02.002.
- Malshe, A., K. Rajurkar, A. Samant, H. N. Hansen, S. Bapat, and W. Jiang. 2013. Bio-inspired functional surfaces for advanced applications. *CIRP Annals - Manufacturing Technology* 62 (2): CIRP:607–28. doi:10.1016/j.cirp.2013.05.008.
- Mezricher, M., T. Brosh, and A. Levy. 2011. Modeling of particle pneumatic conveying using DEM and DPM methods. *Particulate Science and Technology* 29:197–208. doi:10.1080/02726351003792914.
- Nagel, J. K. S., R. L. Nagel, R. B. Stone, and D. A. Mcadams. 2010. Function-based, biologically inspired concept generation. *Artificial Intelligence for Engineering Design, Analysis and Manufacturing* 24 (04):521–35. doi:10.1017/s0890060410000375.
- Niu, S., B. Li, Z. Mu, M. Yang, J. Zhang, Z. Han, and L. Ren. 2015. Excellent structure-based multifunction of morpho butterfly wings: A review. *Journal of Bionic Engineering* 12 (2):170–89. doi:10.1016/s1672-6529(14)60111-6.
- Powell, M. S., N. S. Weerasekara, S. Cole, R. D. LaRoche, and J. Favier. 2011. DEM modelling of liner evolution and its influence on grinding rate in ball mills. *Minerals Engineering* 24 (3–4):341–51. doi:10.1016/j.mineng.2010.12.012.
- Rechenberg, I. 2009. Tribologie im düsensand. *Schlussbericht BMBF-Förderkennzeichen 0311967A*.
- Ren, L. 2009. Progress in the bionic study on anti-adhesion and resistance reduction of terrain machines. *Science in China, Series E: Technological Sciences* 52 (2):273–84. doi:10.1007/s11431-009-0042-3.
- Ren, L., Z. Han, J. Li, and J. Tong. 2002. Effects of non-smooth characteristics on bionic bulldozer blades in resistance reduction against soil. *Journal of Terramechanics* 39 (4):221–30. doi:10.1016/s0022-4898(03)00012-0.
- Ren, L., and Y. Liang. 2010. Biological couplings: Function, characteristics and implementation mode. *Science China Technological Sciences* 53 (2):379–87. doi:10.1007/s11431-010-0043-2.
- Ren, L., J. Tong, S. Zhang, and B. Chen. 1995. Reducing sliding resistance of soil against bulldozing plates by unsmoothed bionics surfaces. *Journal of Terramechanics* 32 (6):303–309. doi:10.1016/0022-4898(96)00001-8.
- Roberts, A. W. 2003. Chute performance and design for rapid flow conditions. *Chemical Engineering & Technology* 26 (2):163–70. doi:10.1002/ceat.200390024.
- Roberts, A. W. 2006. Bulk solids handling: A historical overview and current developments. *Bulk Solids Handling* 26 (6):392–419.
- Roberts, A. W., and S. J. Wiche. 1993. Prediction of lining wear life of bins and chutes in bulk solids handling operations. *Tribology International* 26 (5):345–51. doi:10.1016/0301-679x(93)90071-8.
- Rong, B. 2008. Geometrical structure surfaces with anti-abrasion function and their abrasive wear against soil. PhD thesis, Jilin University.
- Schott, D. L., S. W. Lommen, R. van Gils, J. de Lange, M. M. Kerklaan, O. M. Dessing, W. Vreugdenhil, and G. Lodewijks. 2015. Scaling of particles and equipment by experiments of an excavation motion. *Powder Technology* 278:26–34.
- Schulze, D. 2008. *Powders and bulk solids – behavior, characterization, storage and flow*. Berlin: Heidelberg, NY: Tokyo Springer.
- Tian, X., Z. Han, X. Li, Z. Pu, and L. Ren. 2010. Biological coupling anti-wear properties of three typical molluscan shells: *Scapharca subcrenata*, *Rapana venosa* and *Acanthochiton rubrolineatus*. *Science China Technological Sciences* 53 (11):2905–913. doi:10.1007/s11431-010-4131-0.
- Tong, J., Y. Ma, L. Ren, and J. Li. 2000. Tribological characteristics of pangolin scales in dry sliding. *Journal of Materials Science Letters* 19 (7):569–72.
- Tong, J., T. Lü, Y. Ma, H. Wang, L. Ren, and R. D. Arnell. 2007. Two-body abrasive wear of the surfaces of pangolin scales. *Journal of Bionic Engineering* 4 (2):77–84. doi:10.1016/s1672-6529(07)60017-1.
- Vincent, J. F. V., O. A. Bogatyreva, N. R. Bogatyrev, A. Bowyer, and A. Pahl. 2006. Biomimetics: Its practice and theory. *Journal of the Royal Society*, 3 (9):471–82. doi:10.1098/rsif.2006.0127.
- Vincent, J. F. V., O. Bogatyreva, A. Pahl, N. Bogatyrev, and A. Bowyer. 2005. Putting biology into TRIZ: A database of biological effects. *Creativity and Innovation Management* 14 (1):66–73. doi:10.1111/j.1476-8691.2005.00326.x.
- Vincent, J. F. V., and D. L. Mann. 2002. Systematic technology transfer from biology to engineering. *Philosophical Transactions of the Royal Society of London A* 360 (1791):159–73. doi:10.1098/rsta.2001.0923.
- Yu, C., and Q. Wang. 2012. Friction anisotropy with respect to topographic orientation. *Scientific Reports* 2:988. doi:10.1038/srep00988.
- Zhang, J., Z. Han, R. Ma, W. Yin, Y. Lü, and L. Ren. 2013. Scorpion back inspiring sand-resistant surfaces. *Journal of Central South University* 20 (4):877–88. doi:10.1007/s11771-013-1561-4.
- Zhang, R., Z. Lu, and J. Li. 2010. Abrasive wear of geometrical surface structures of *Scapharca subcrenata* and Burnt-End Ark against soil. *Advances in Natural Science* 3 (2):213–17.