

Building Technology mentor: Pierre Jennen

Architecture mentor: Roel van de Pas

Research mentor: Luc Willekens

Delegate of the Board of Examinors: Daan Vitner

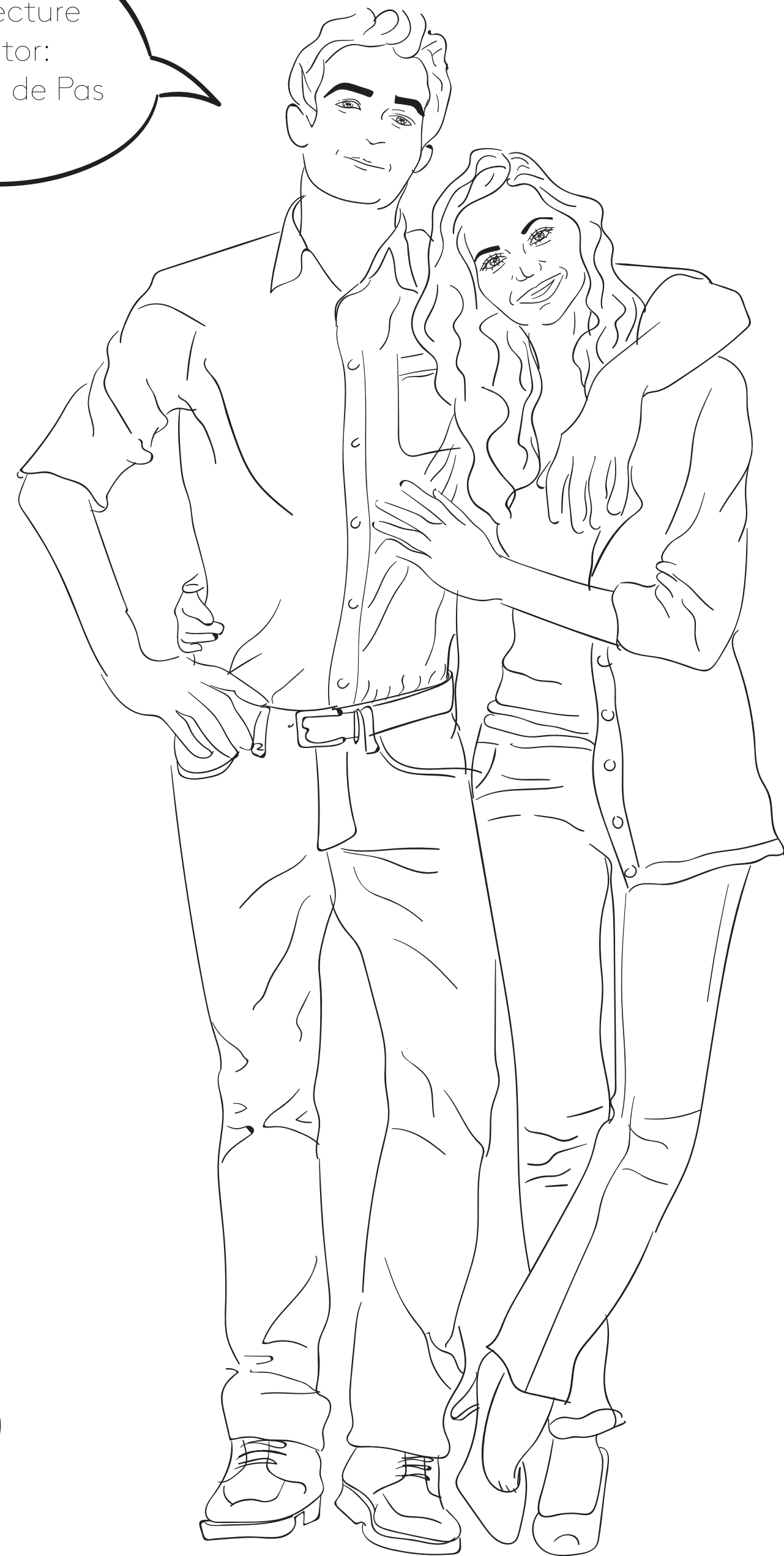
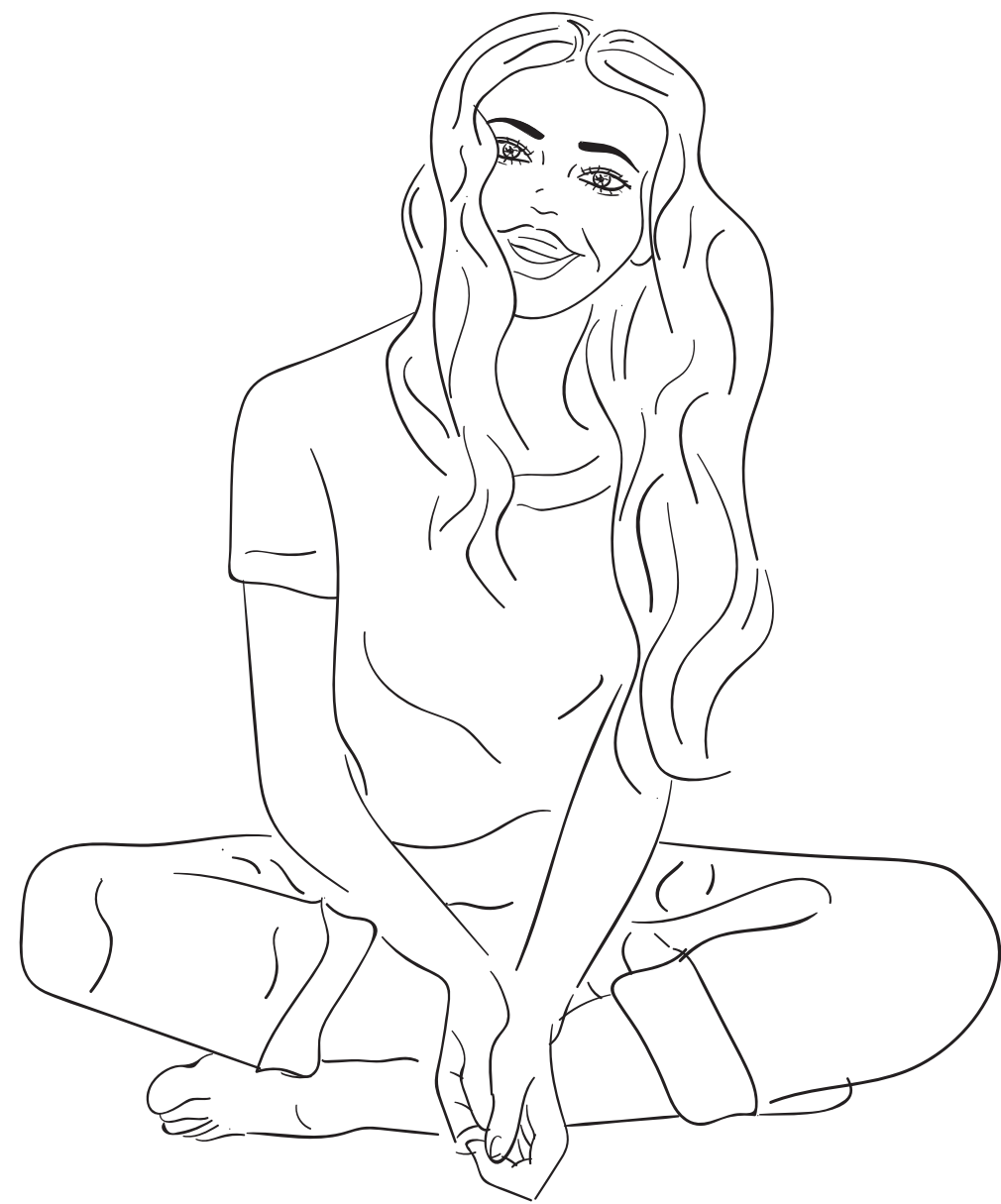

# a perfect fit

creating supportive housing for the autistic

faculty of Architecture and the Built Environment

Laura Francisca van Beek  
4246462



P5 graduation  
Explore Lab studio  
25-01-2019



fascination  
theoretic frame  
problem statement  
research  
results  
location  
design  
questions



Laura van Beek  
the older sister

Anne van Beek  
8 minutes younger  
has Autism Spectrum  
Disorder

# fascination

what does autism mean for Anne?



very sensitive to noise

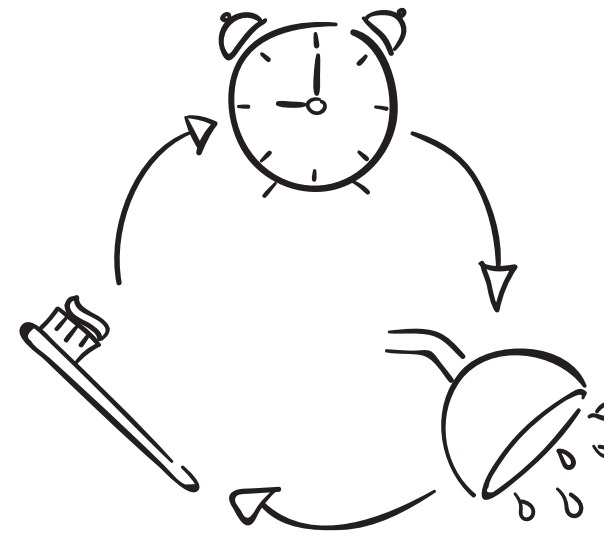

loves order and routine



is very social



shuts down when being overwhelmed or over demanded

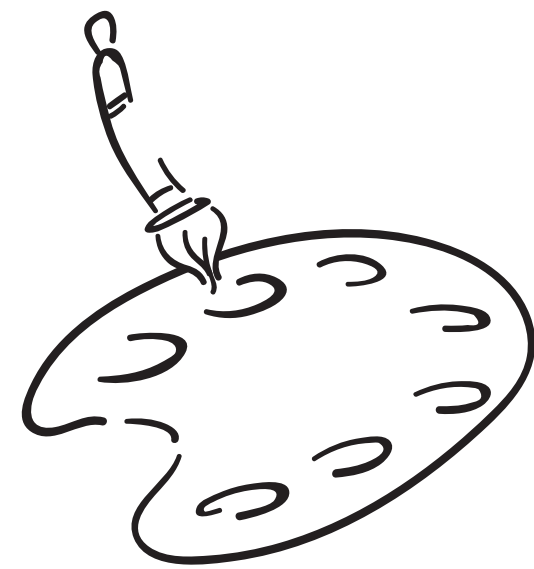

extremely creative



gets uncomfortable in (very) large crowds



*theoretic frame*

autism prevalence

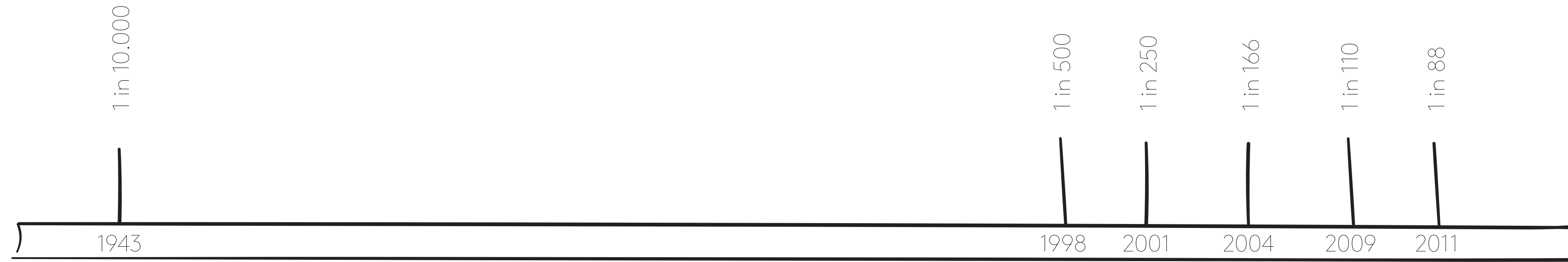

Leo Kanner diagnoses first case of autism

Lancet article links autism to vaccines, later retracted

78% increase

why is this increasing?

> society has increasingly become more demanding and complex

> diagnostics now include also:

- x PDD-NOS  
(Pervasive Developmental Disorder - Not Otherwise Specified)
- x Asperger's Syndrome

# the autism spectrum

common perception

a "little" autistic

"very" autistic

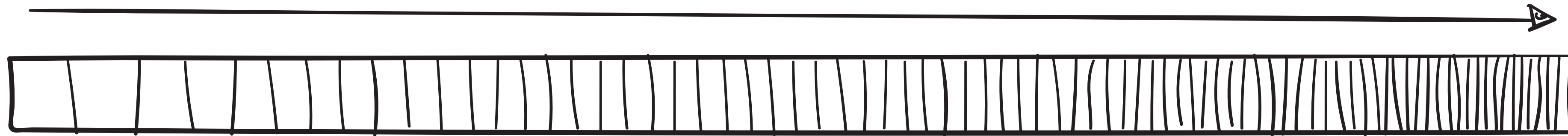

where would Anne fit?

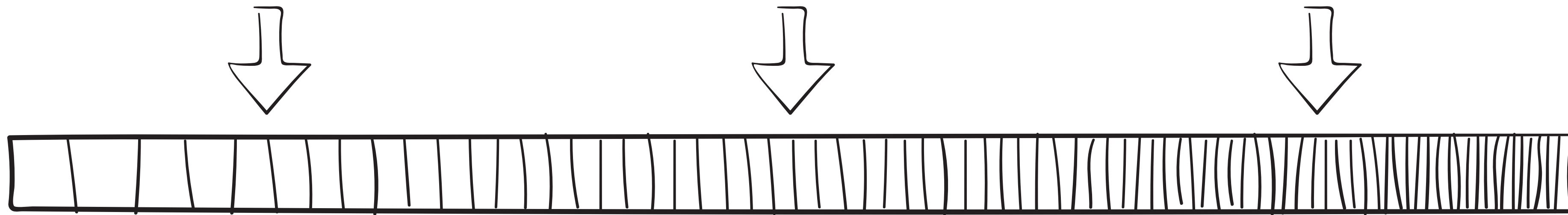

she is quite socially skilled, so she can't be THAT autistic

hmm, but she doesn't like unexpected events

She is very creative and good at telling about WW2 and remembering details

and she is very sensitive to noise, she is very SCARED of fireworks



new model proposal: the 'spiderweb'

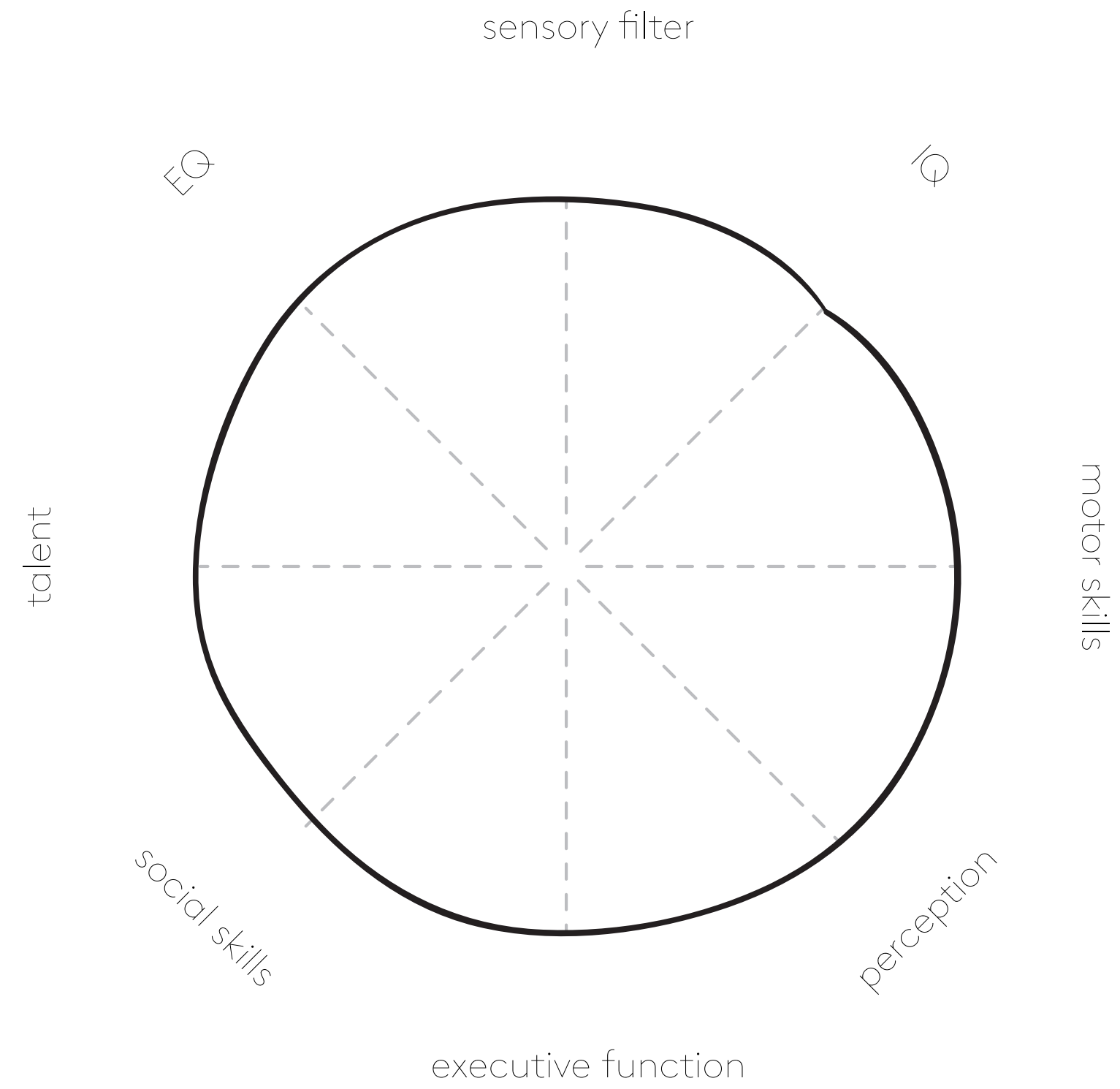

new model proposal: the 'spiderweb'

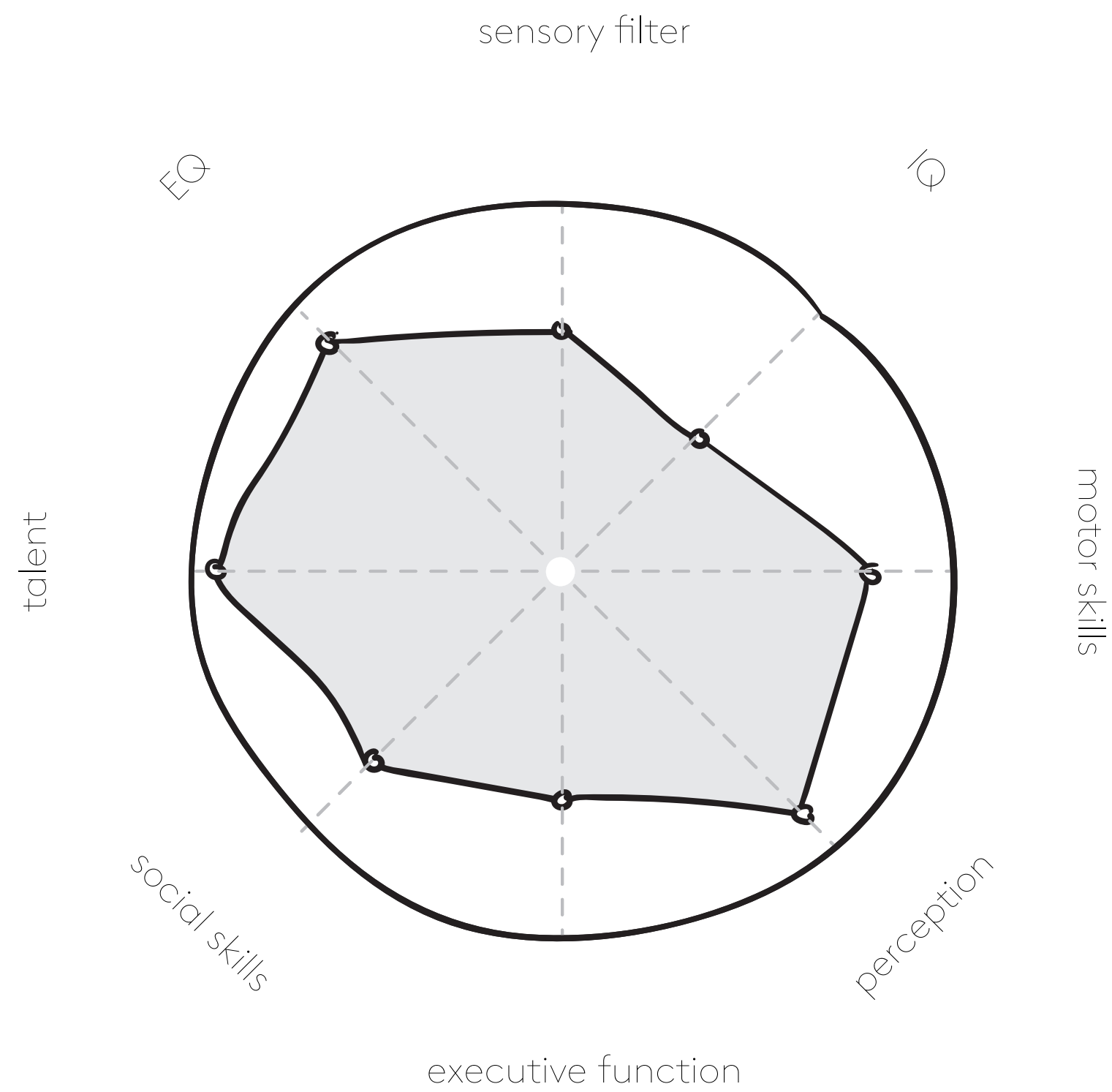

# the autism spectrum

a big variety of individuals

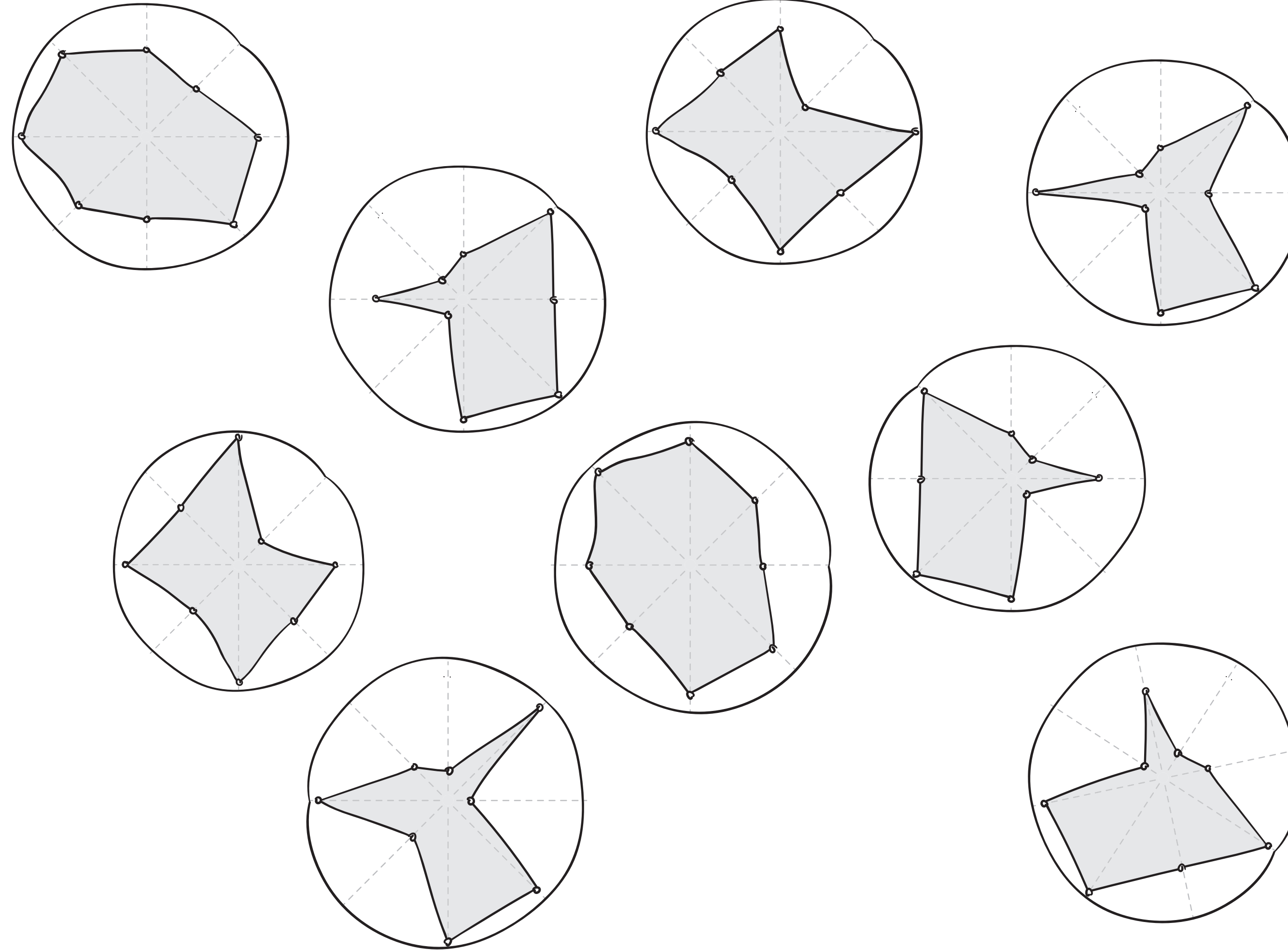

# how to create housing for such a wide range of individuals

my own position/perspective

focus on individuals who are balancing on the verge of independence:

- > not independent enough to buy/rent a "normal" house
- > too independent for full tutoring

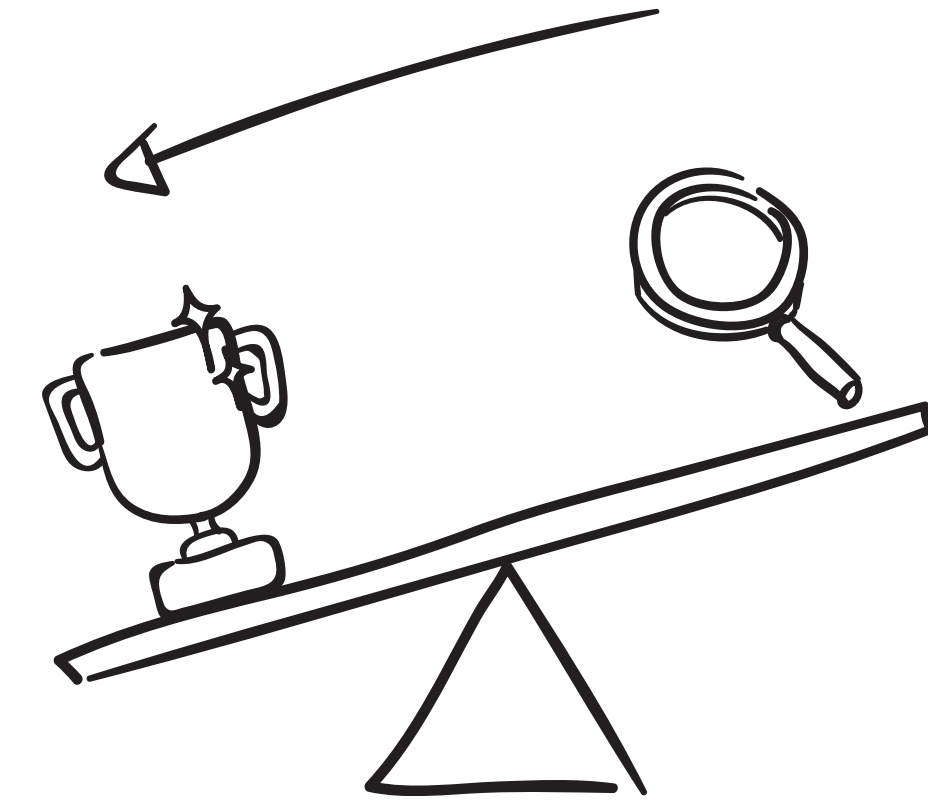

up to 95% of the people with autism have "any unusual sensory experiences"

Ahrentzen, Steele & Dorgan, 2013

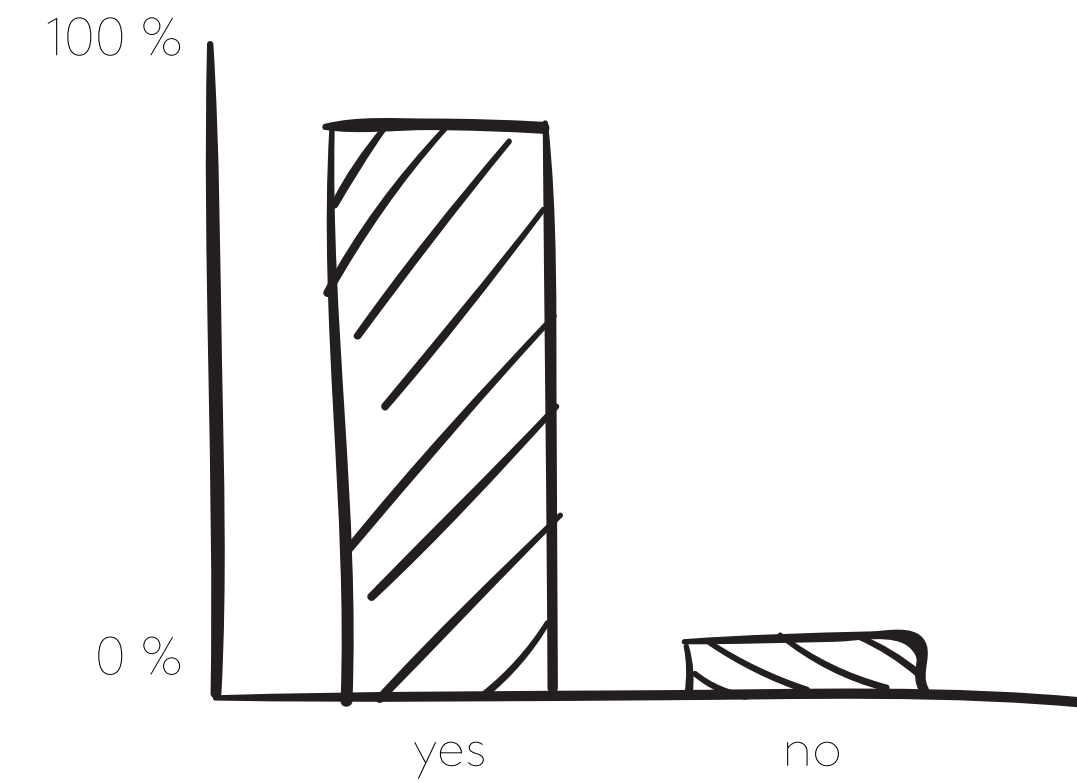

*problem statement*

wishes for housing situations

“do you wish for another housing situation?”

adults > 18	
yes	41%
maybe	29%
no	24%
unknown	6%
total	100% n = 830

Nederlande Vereniging voor Autisme, questionnaire report, 2013

“what kind of housing situation are you searching for?”

adults > 18	
independent with very little tutoring	43%
independent without care or support	22%
other	35%
total	100% n = 864

Nederlande Vereniging voor Autisme, questionnaire report, 2013

# problem statement

special schools are well equipped



[www.therapyinsider.com](http://www.therapyinsider.com)



[www.inhabitat.com](http://www.inhabitat.com)



[www.afternic.com](http://www.afternic.com)



[www.tritecre.com](http://www.tritecre.com)

# problem statement

but housing seems to stay behind



practical linoleum flooring



still an institutional-like feeling, instead of home-like



how it should be

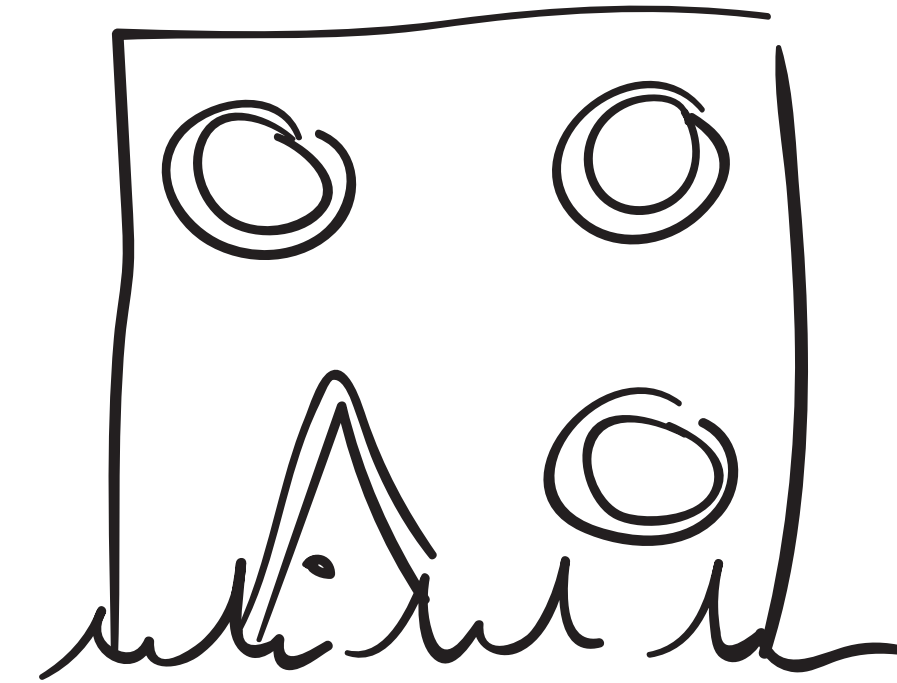
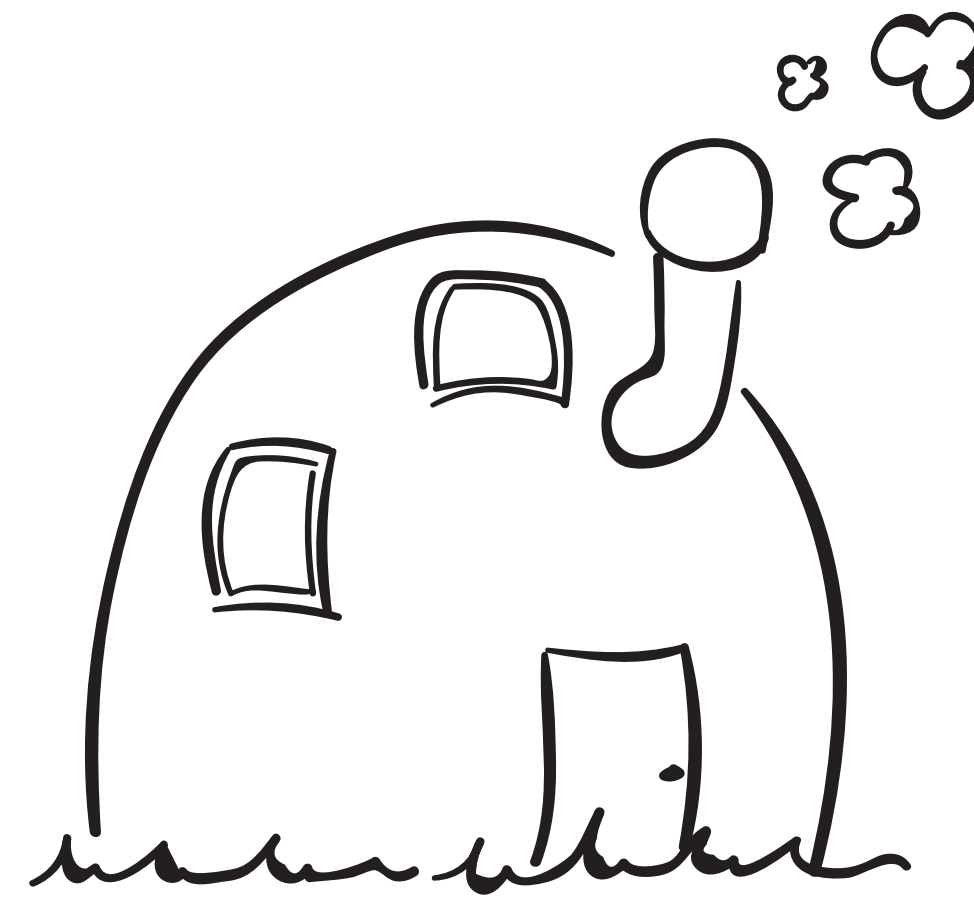

recognisable

cosy and home-like ("gezellig")

supportive

# problem statement

why should it be like that?

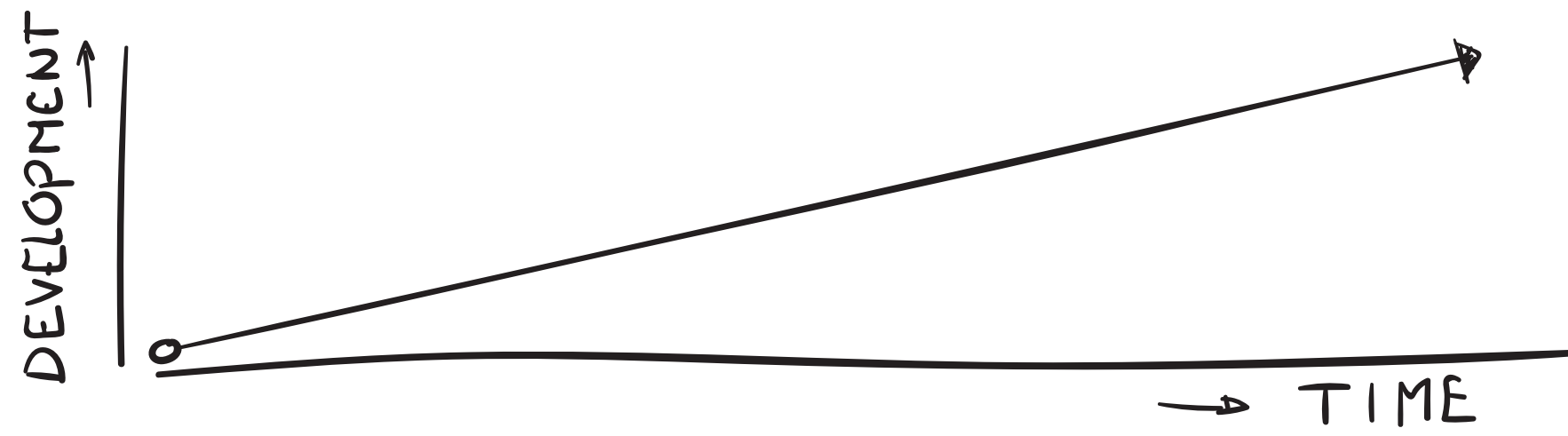
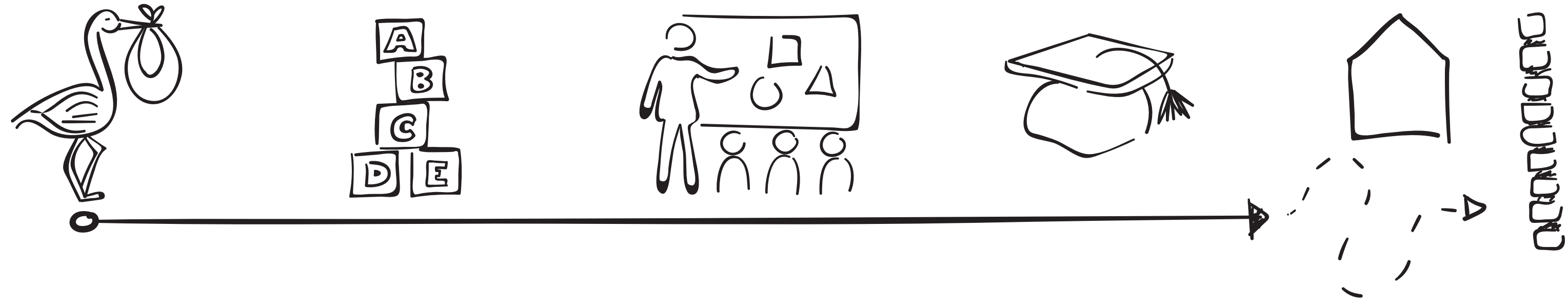

neurotypical person



autistic person

research

research questions

Which architectural elements can increase the well-being of people with autism within their home environment?

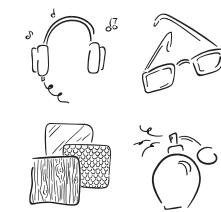

In what manner can sensory architecture come into play?



Which measures considering privacy have to be taken?



In which way should social interaction be supported?



How should the balance be found between generalism and personalisation?

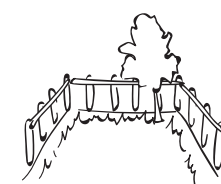

How can the connecting outdoor space make a contribution?

goal

Goal

to set up guidelines for architects who are designing houses for people with autism

Scope

- x location: Leiden
- x target group: focus on individuals who are balancing on the verge of independence
- x housing type: individual apartments with a communal support point

research method

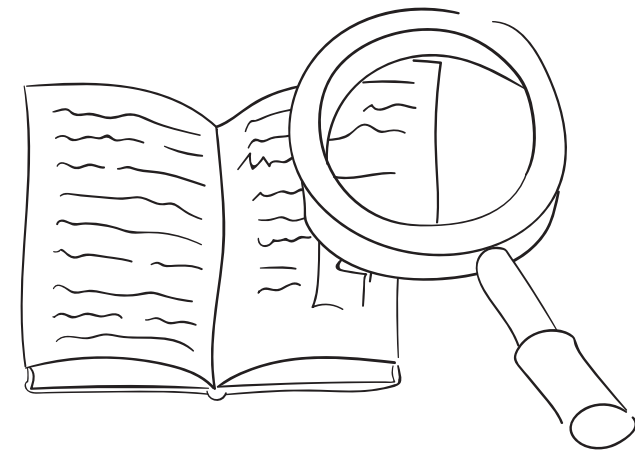

literature study

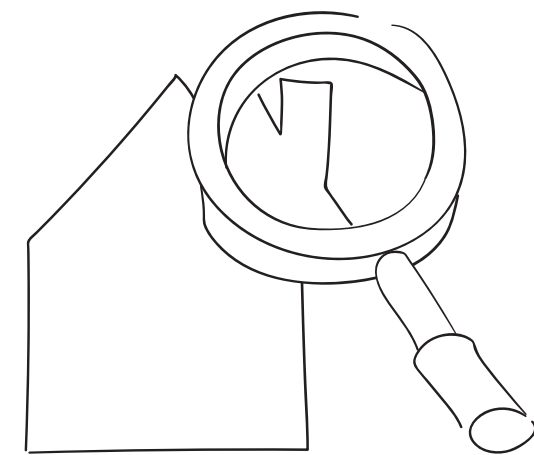

typological study



questionnaire & interviews

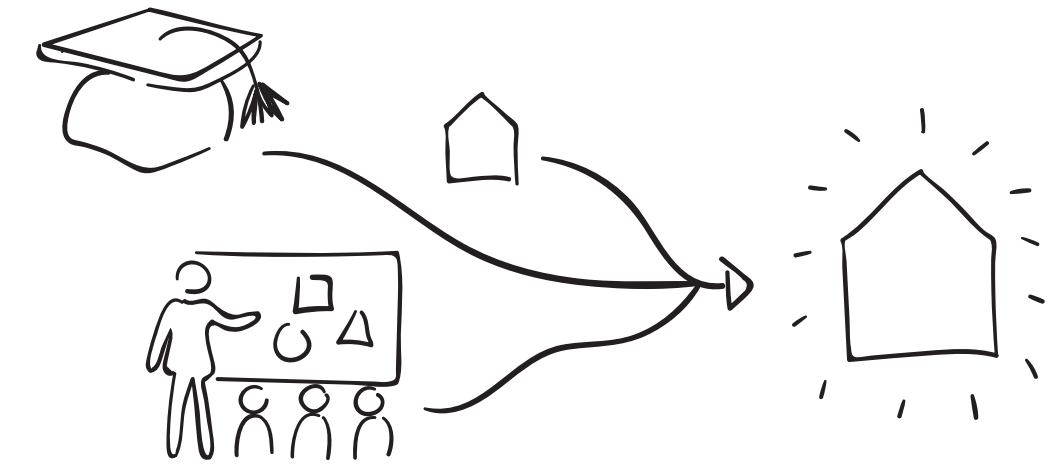

questionnaire

6 residents

- x currently living in either group housing (waiting for independent housing) or already in a studio apartment.

interviews

2 tutors

- x tutors in group housing, will move with the residents to the new apartment building

1 resident

- x moving to an individual apartment with partial tutoring.

results

problems - categories and themes

spatial

layout

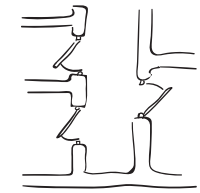

wayfinding

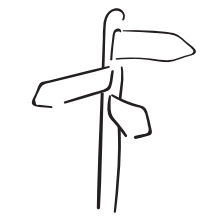

furnishings



personalisation

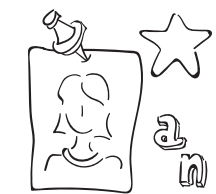

sensory

sound



sight



touch

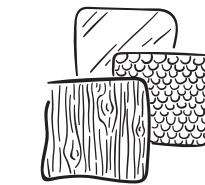

smell



garden

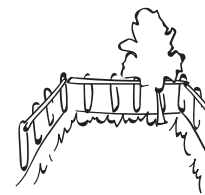

social

privacy



interaction





problems

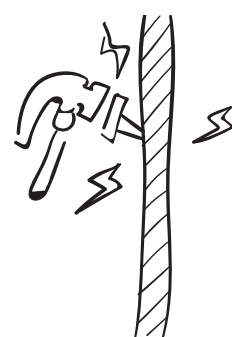

contact noise

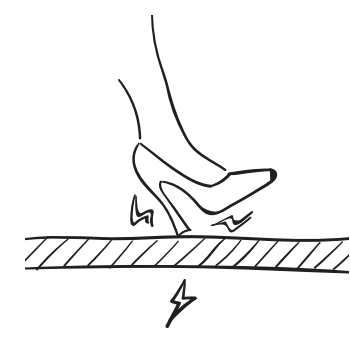

impact noise

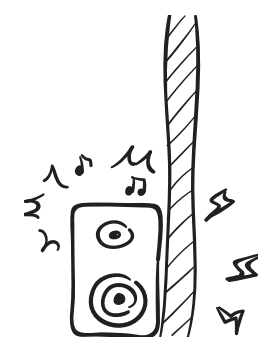

loud music



electrical appliances

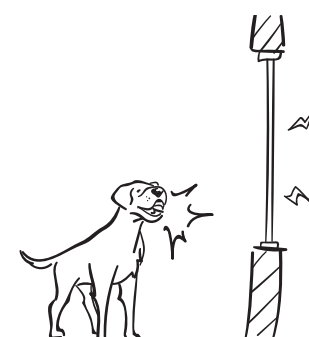

barking dogs

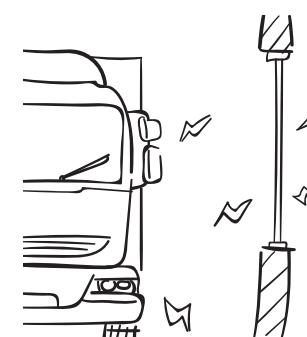

noisy traffic

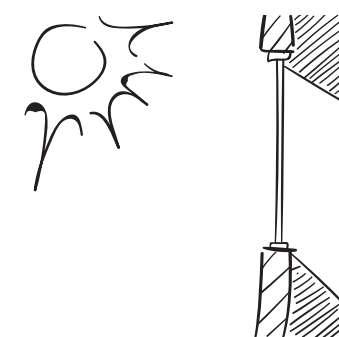

bright sunlight

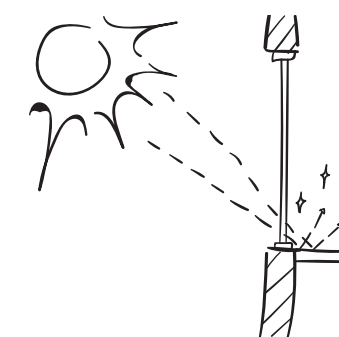

glare and reflection

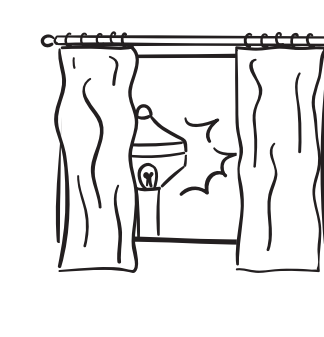

street lantern light



emergency exit light

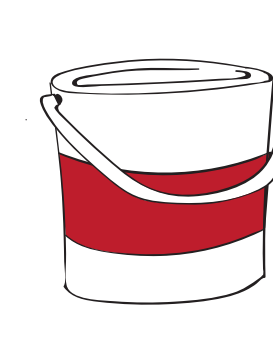

red increases stress



blue enlarges a space

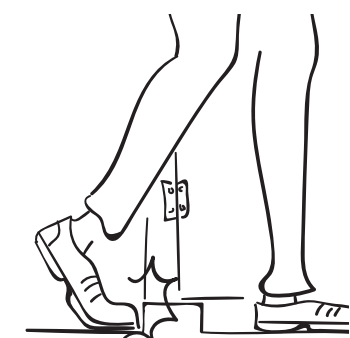

high thresholds

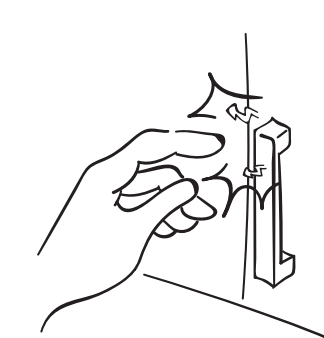

shock by metal objects

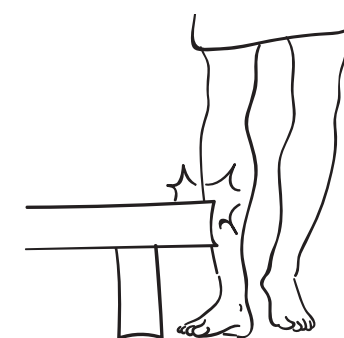

sharp edges



temperature sensitive

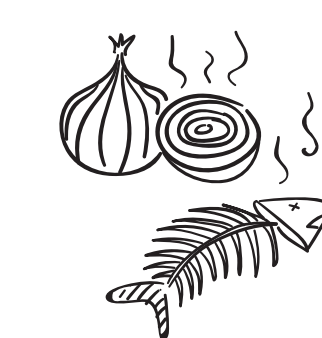

kitchen smells

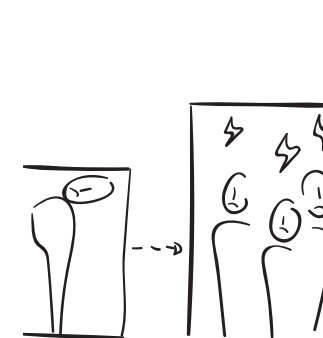

too little private space

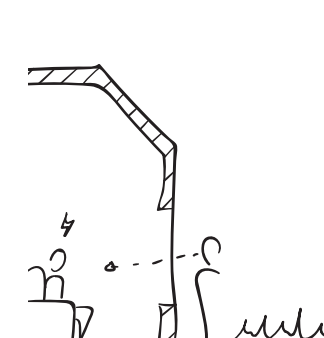

passersby looking in



feelings of unsafety

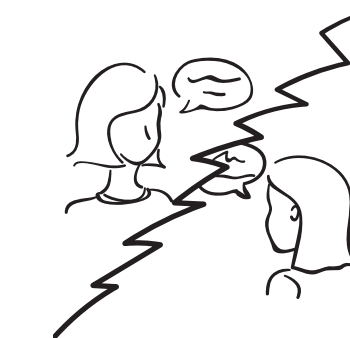

unable to converse



misinterpreting things

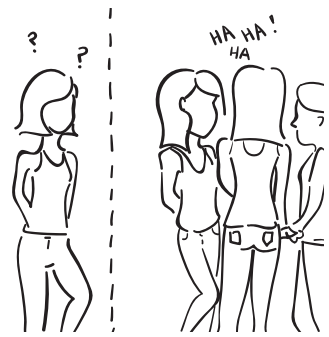

social exclusion

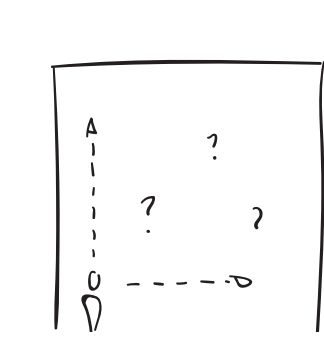

space seems larger



current room too small

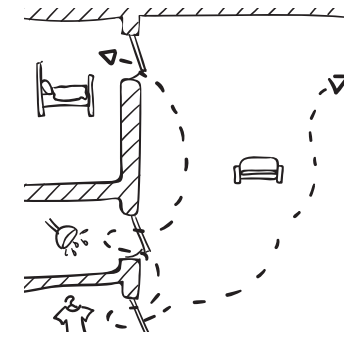

unlogical routine space

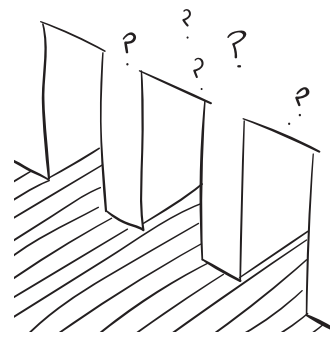

too many hallways

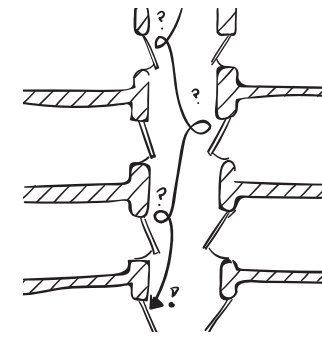

too many doors

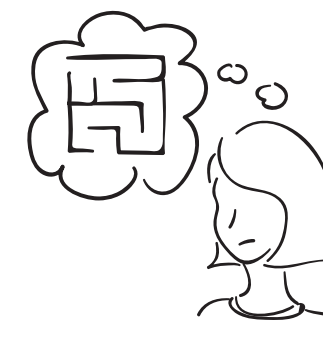

layout not memorable

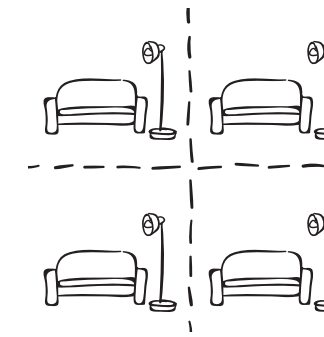

generic furnishings

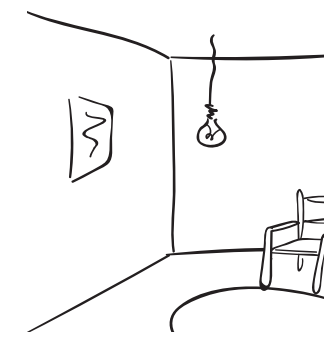

bare furnishings

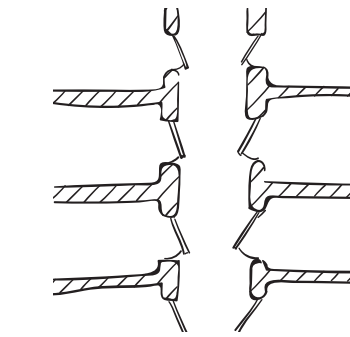

institution-like feeling



obliged regulations

problems

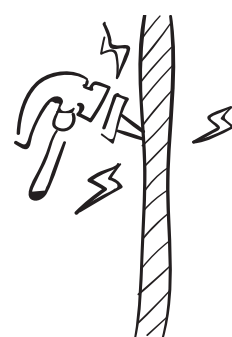

contact noise

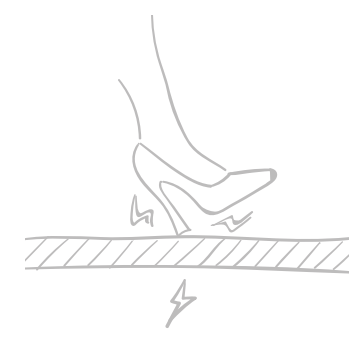

impact noise



loud music



electrical appliances



barking dogs



noisy traffic

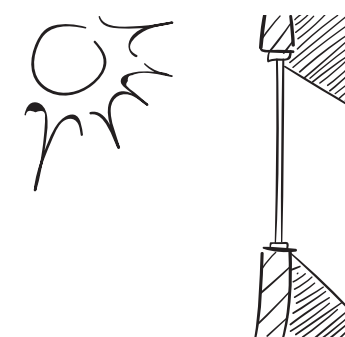

bright sunlight

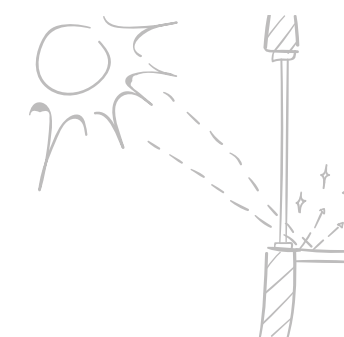

glare and reflection



street lantern light



emergency exit light

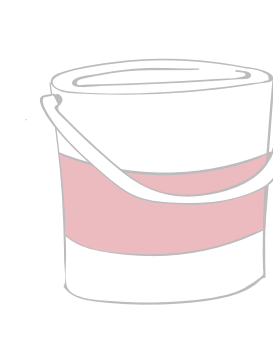

red increases stress



blue enlarges a space



high thresholds

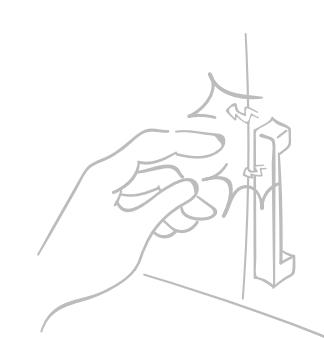

shock by metal objects

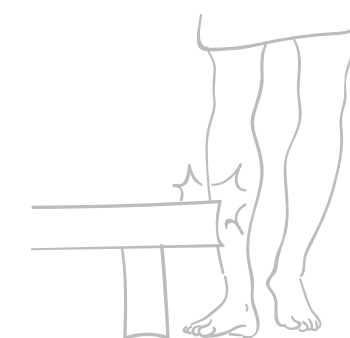

sharp edges



temperature sensitive



kitchen smells

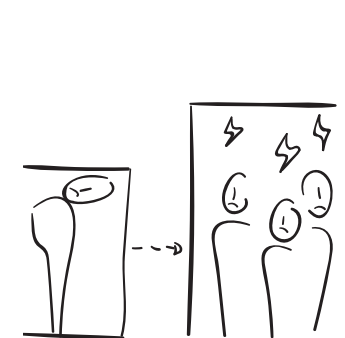

too little private space

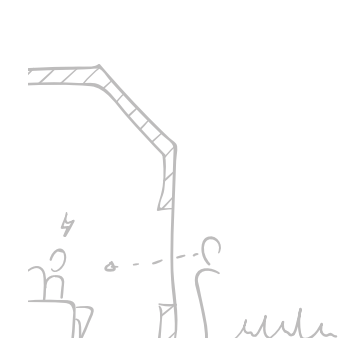

passersby looking in



feelings of unsafety



unable to converse



misinterpreting things

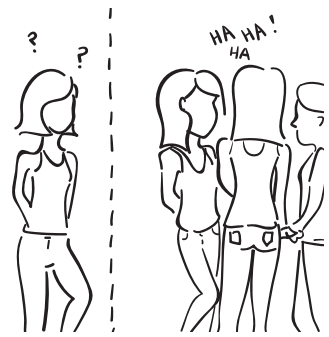

social exclusion

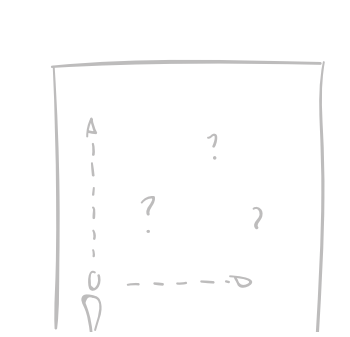

space seems larger



current room too small

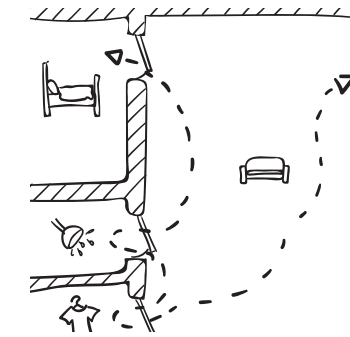

unlogical routine space

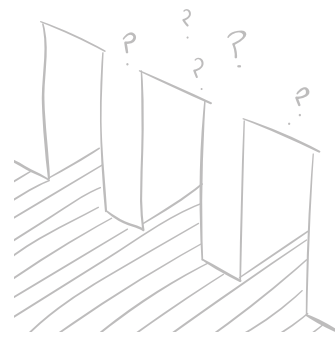

too many hallways

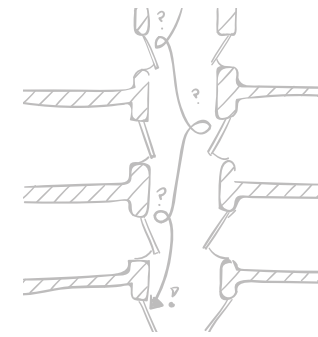

too many doors



layout not memorable

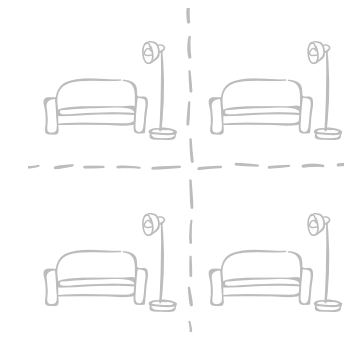

generic furnishings

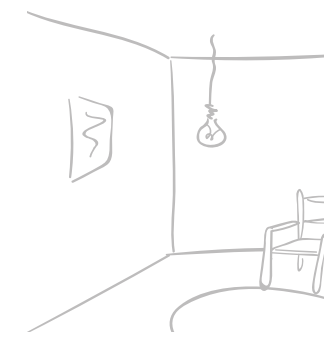

bare furnishings

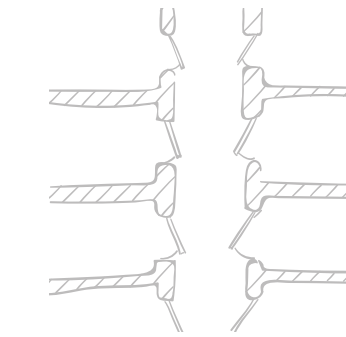

institution-like feeling



obliged regulations

solutions - categories and themes

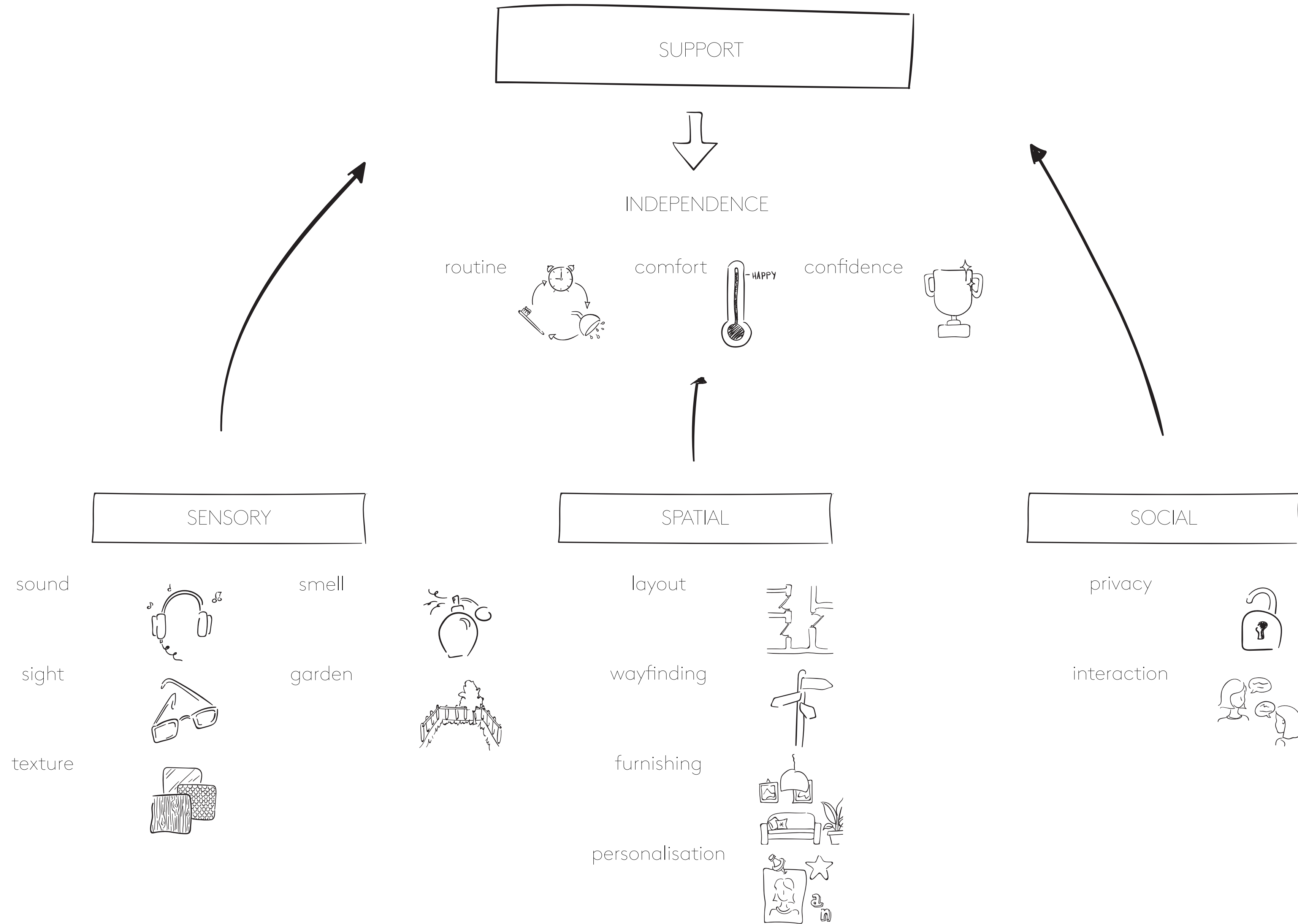

solutions

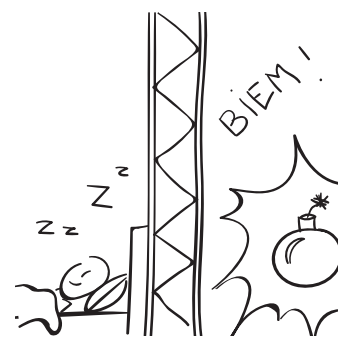

outstanding insulation

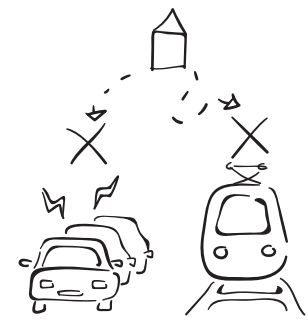

location consideration

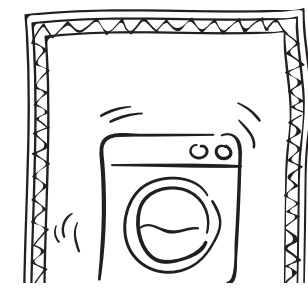

insulated cabins

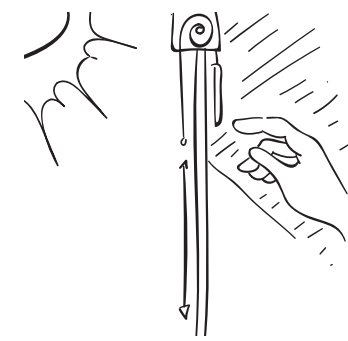

sunshading

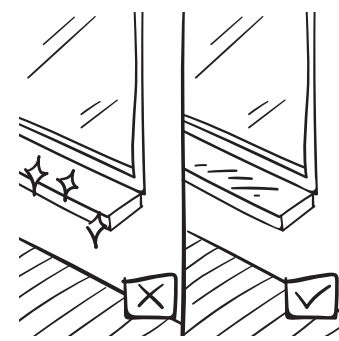

matte finishes

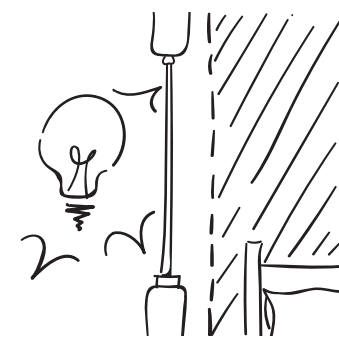

darkness

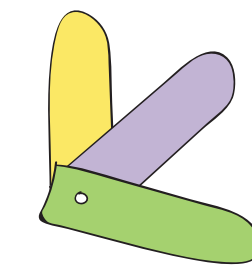

use of soft pastels

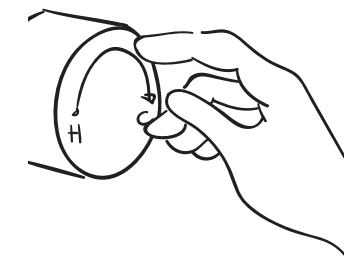

temperature control

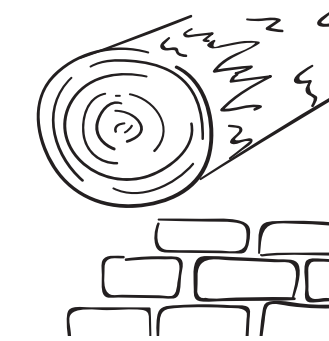

non-metal materials

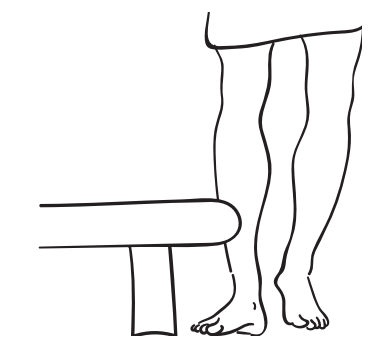

round corners

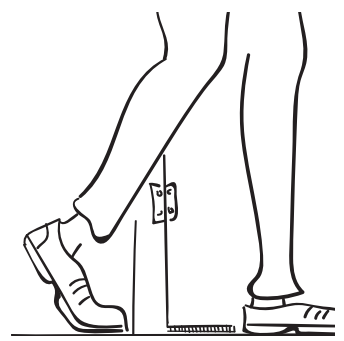

no thresholds

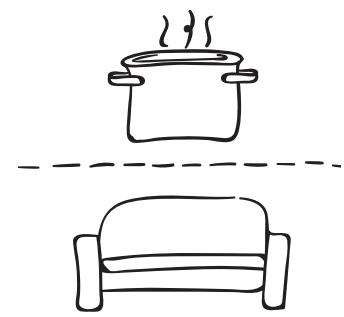

kitchen separate

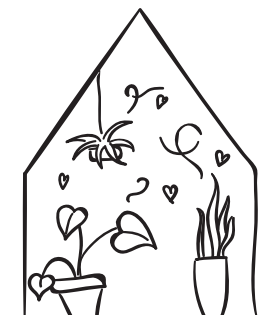

air-purifying plants

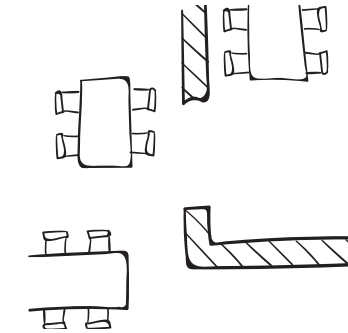

several privacy levels

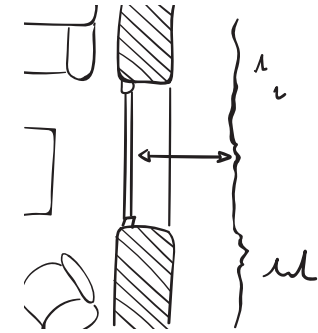

deep niches of windows

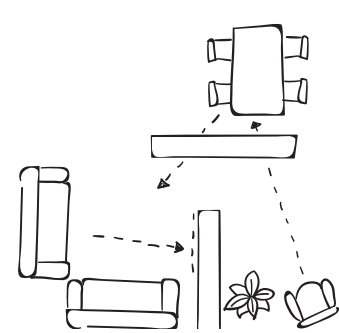

space dividers

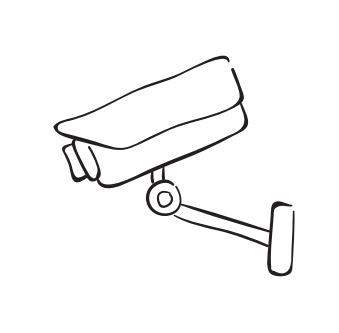

offer safety measures

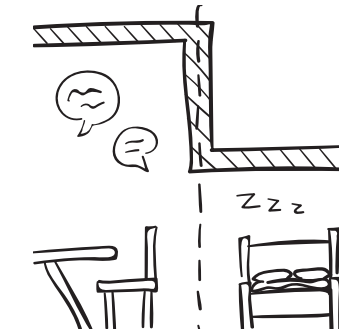

ceiling height influence

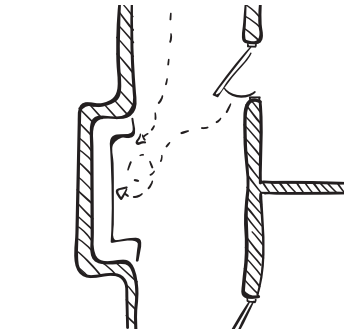

informal seating



previewing 1

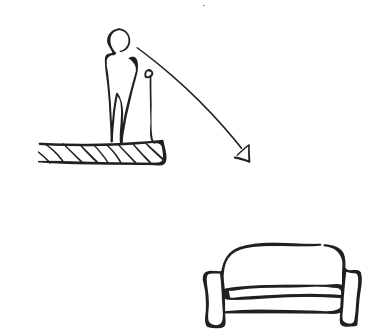

previewing 2

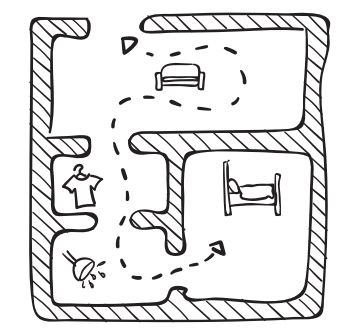

routine expectations

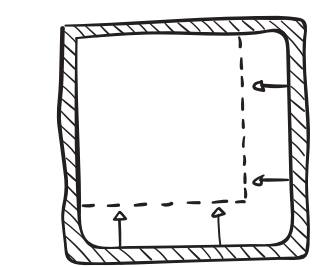

avoid too large spaces

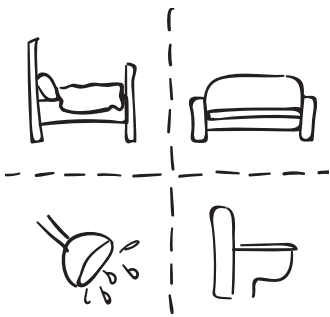

different functions

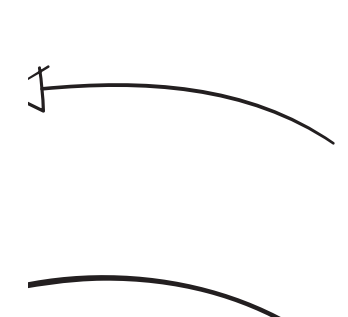

curvilinear walls

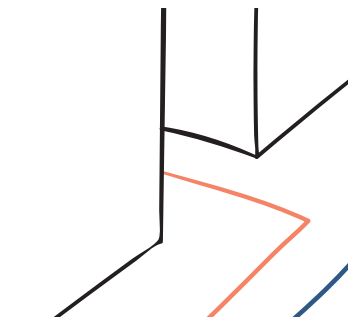

coloured flooring

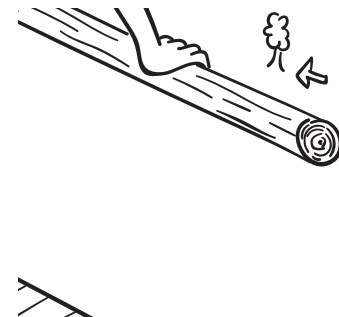

textured railings

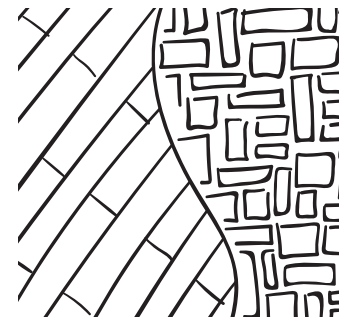

functions vs. textures

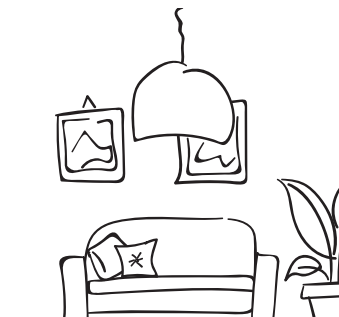

homey furnishings

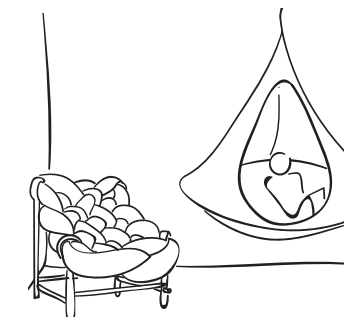

comforting furniture



front door decoration

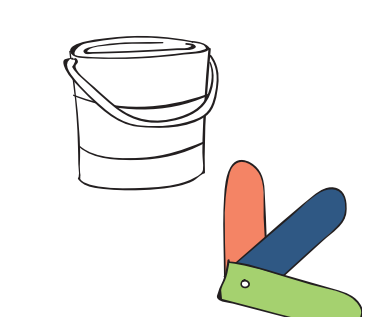

colour picking

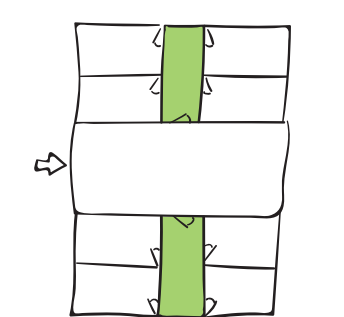

shorter hallways

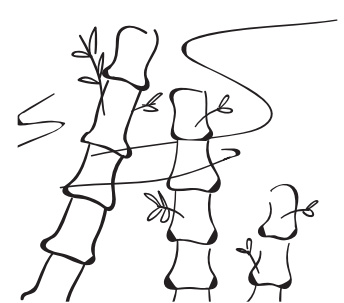

bamboo knocks softly

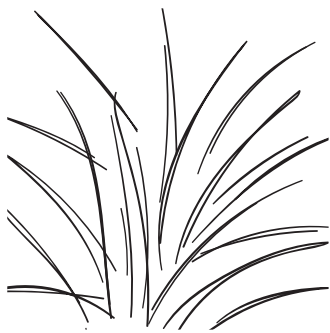

long grasses rustle



weeping or cascading



cool colours give peace



warm colours activate



soft lamb's ear

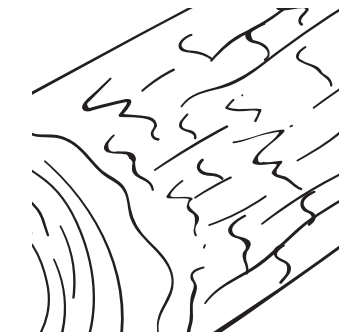

rough bark



fragrant plants



fragrant herbs



edible plants

solutions

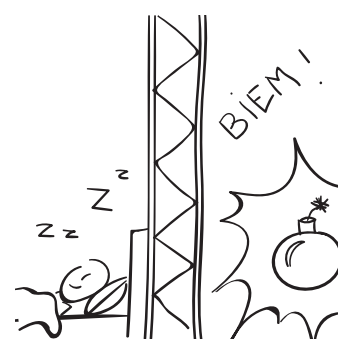

outstanding insulation

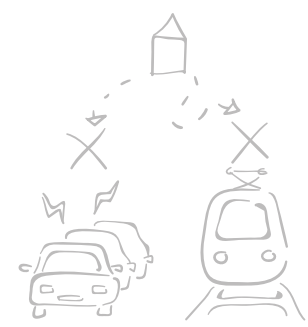

location consideration

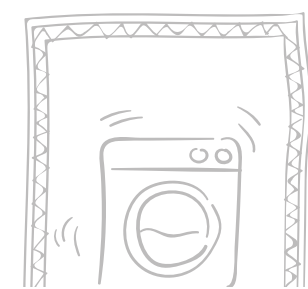

insulated cabins

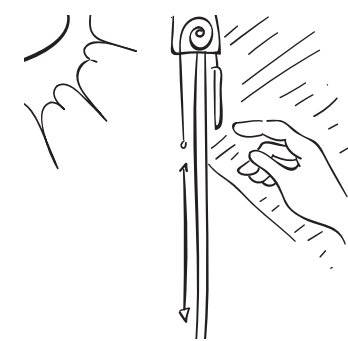

sunshading

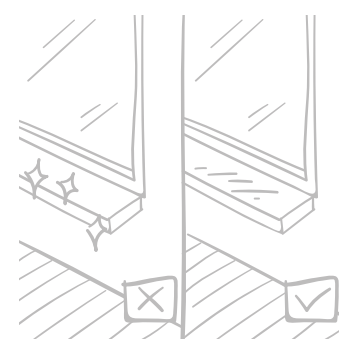

matte finishes

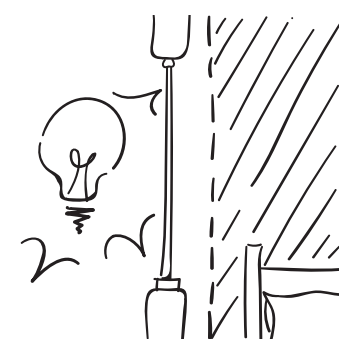

darkness

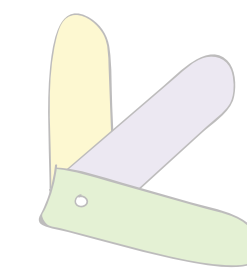

use of soft pastels

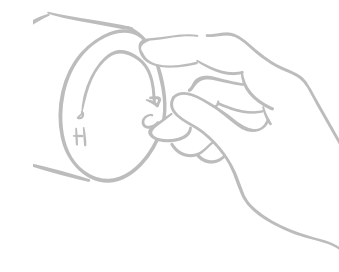

temperature control



non-metal materials

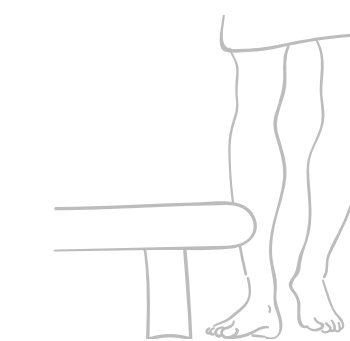

round corners



no thresholds

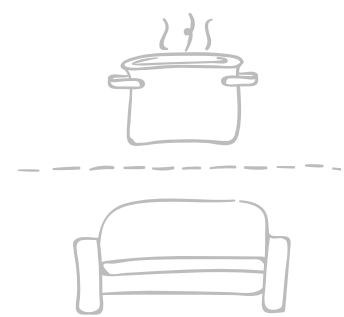

kitchen separate



air-purifying plants

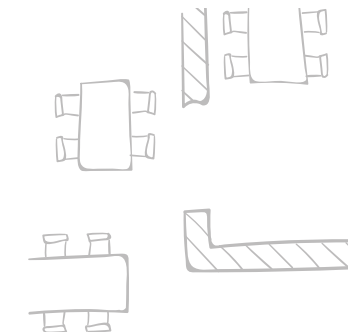

several privacy levels

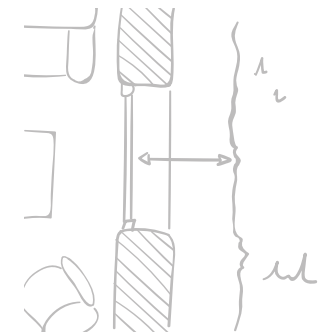

deep niches of windows

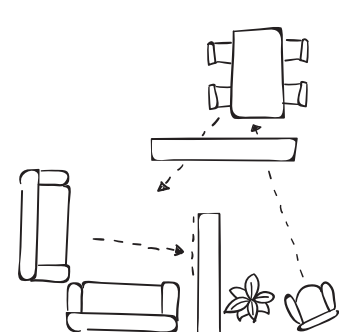

space dividers

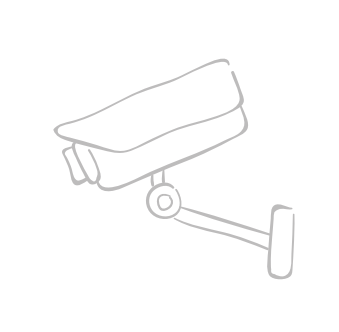

offer safety measures



ceiling height influence

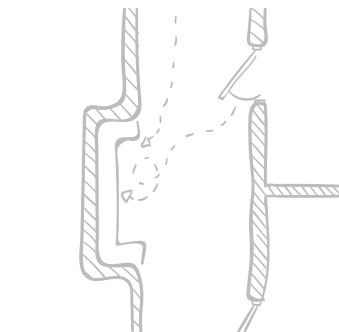

informal seating

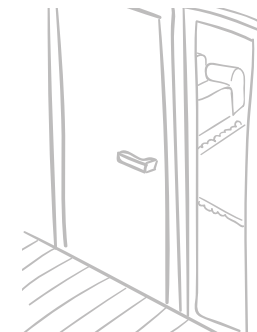

previewing 1

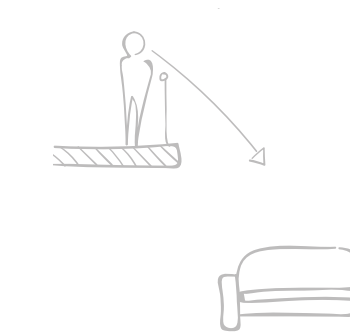

previewing 2

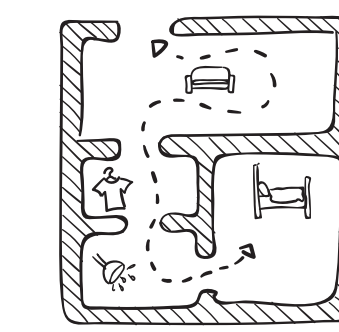

routine expectations

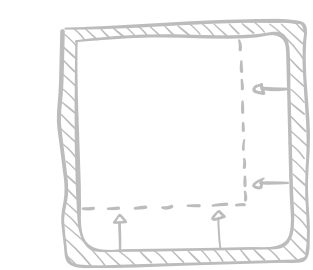

avoid too large spaces

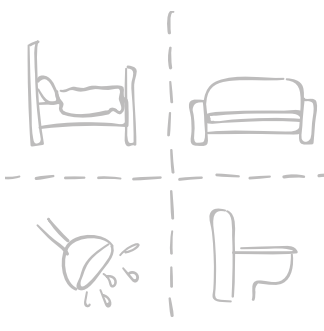

different functions

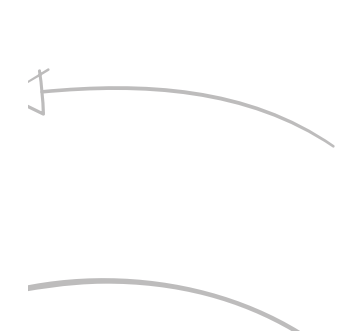

curvilinear walls

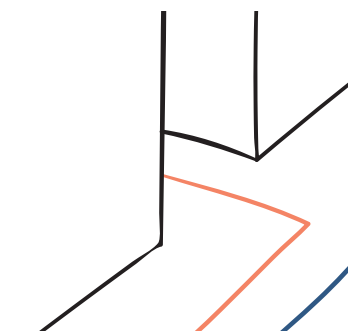

coloured flooring

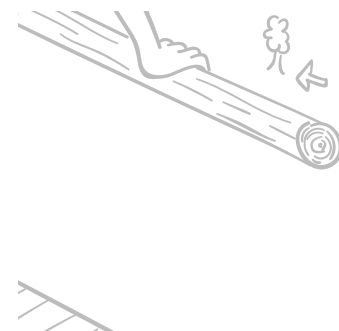

textured railings



functions vs. textures



homey furnishings



comforting furniture

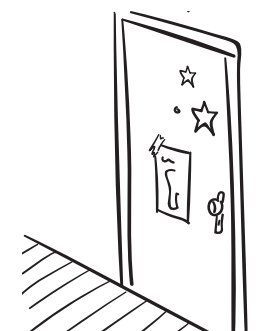

front door decoration

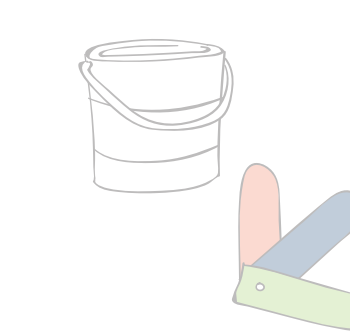

colour picking

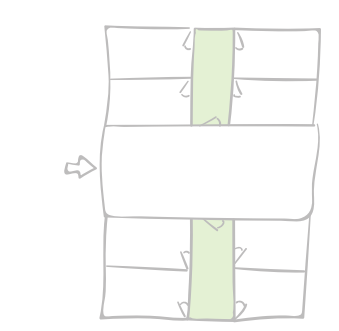

shorter hallways



bamboo knocks softly

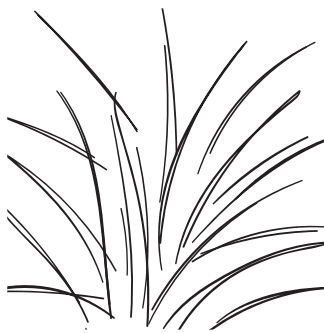

long grasses rustle



weeping or cascading



cool colours give peace



warm colours activate



soft lamb's ear

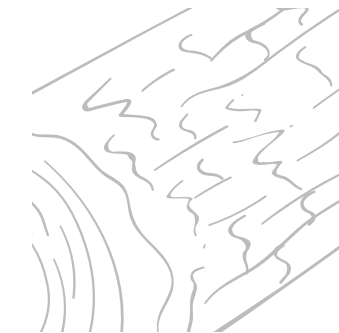

rough bark



fragrant plants



fragrant herbs



edible plants

- x decrease sensory load concerning sound, sight, touch and smell ;
- x develop a spatial layout which creates expectations for action ;
- x maximise familiarity and clarity ;
- x create "islands" of privacy throughout building, apartment, and outdoor area ;
- x allow opportunities for social interaction - both accidental and planned ;  
> include a way of previewing for mental preparation
- x ensure accessibility and inclusion in the surrounding neighbourhood ;
- x allow for a high level of personalisation to enhance identity ;
- x provide control of services like heating and sunshading ;
- x be always alert on the balance between their world and the outdoor world ;

*location*

# location choice

method of analysis



positive factors combined

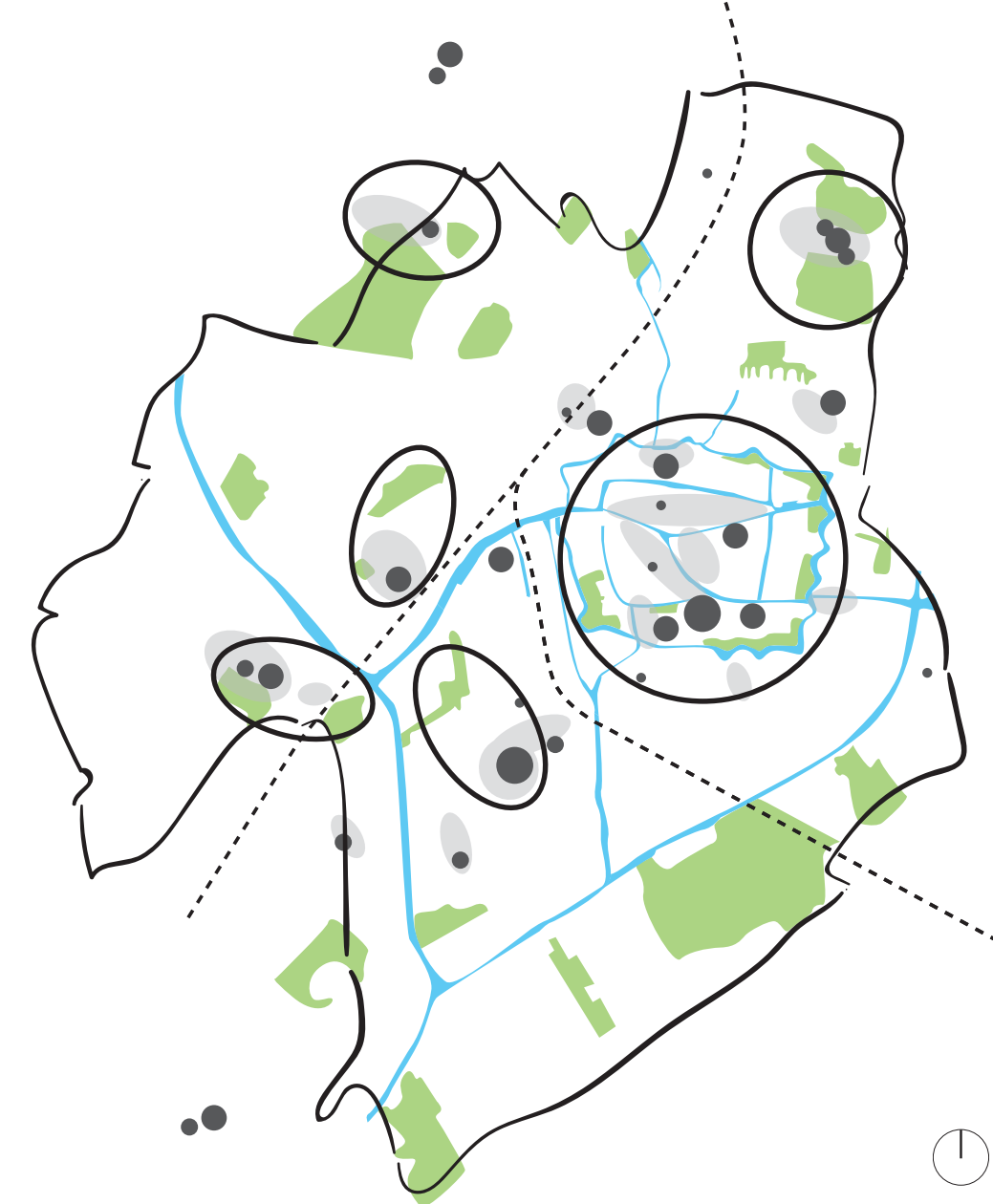

negative factors combined

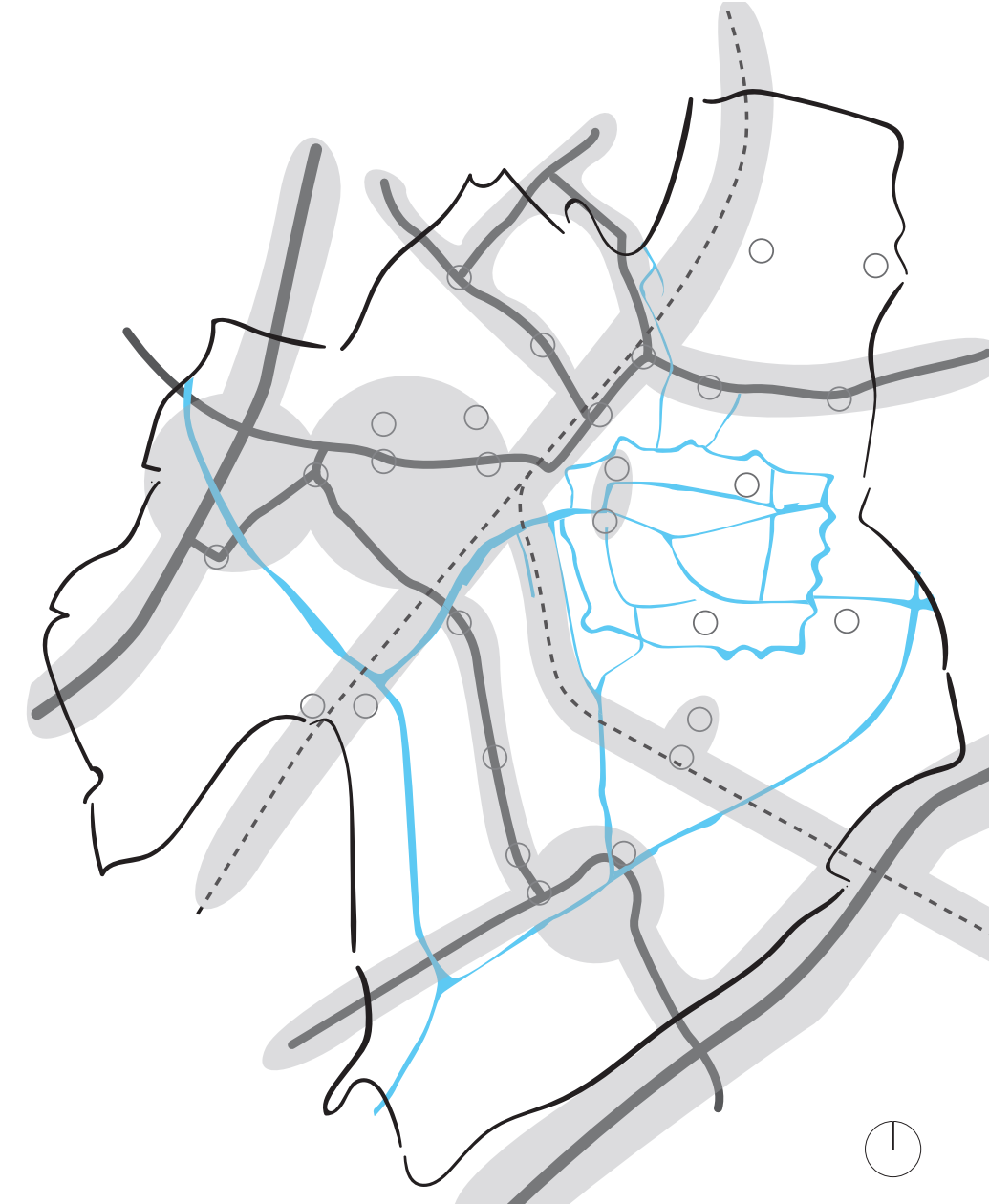

remaining area's

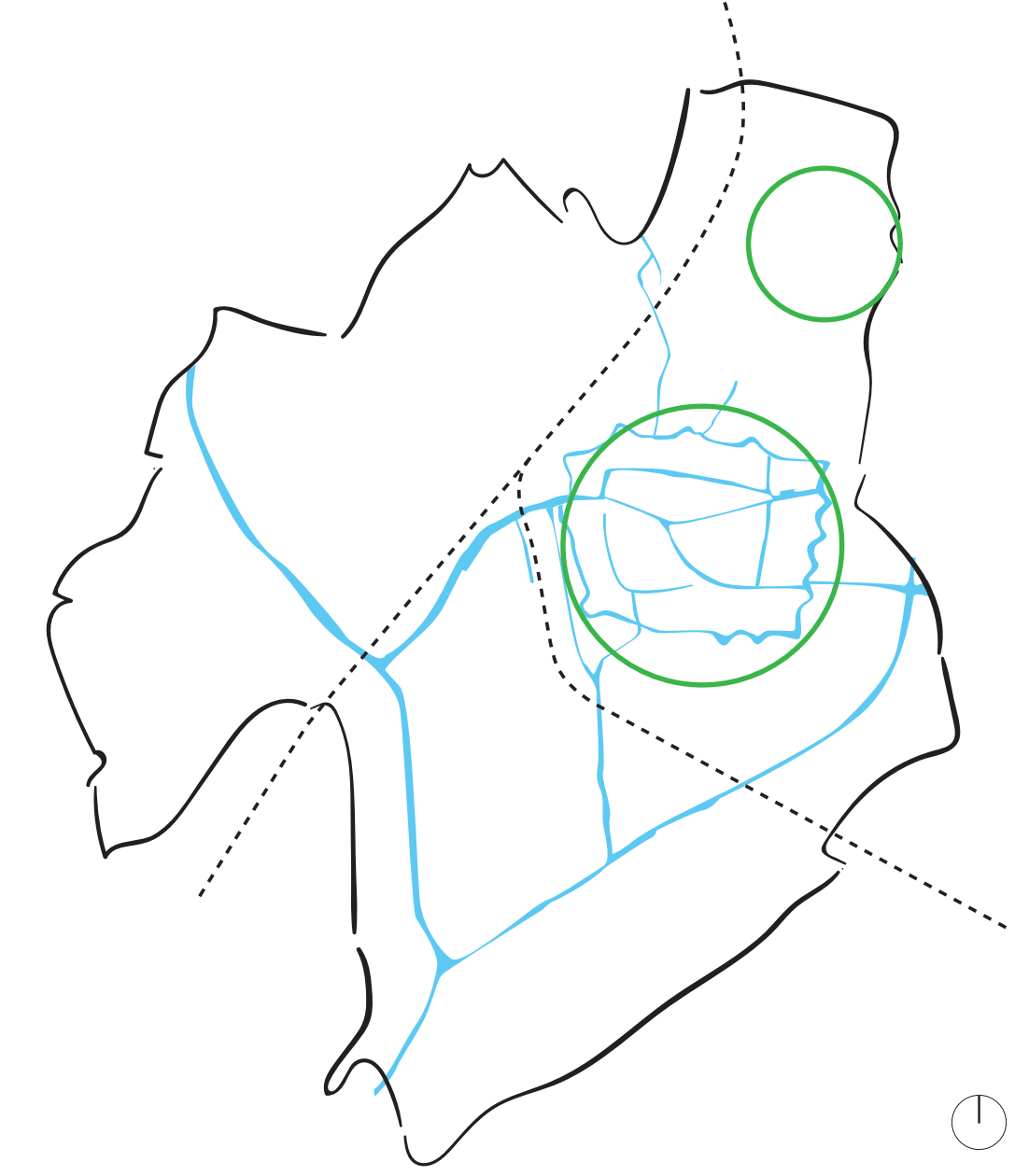

sound



light



colour

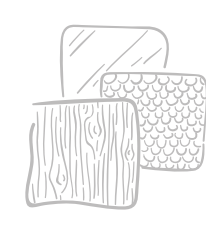

texture



smell



privacy

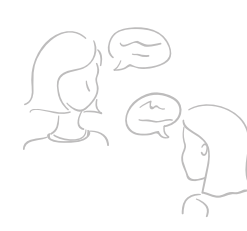

interaction

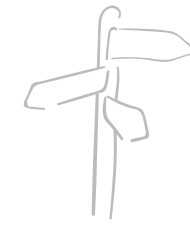

wayfinding

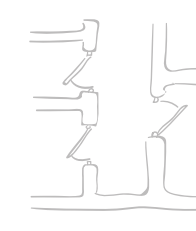

layout



personalisation



nature



comfort



routine



confidence



# location choice

Kaasmarkt, Leiden

Walk 17 min  
 Bicycle 5 min  
 Car 6 min  
 Public Transport 11 min

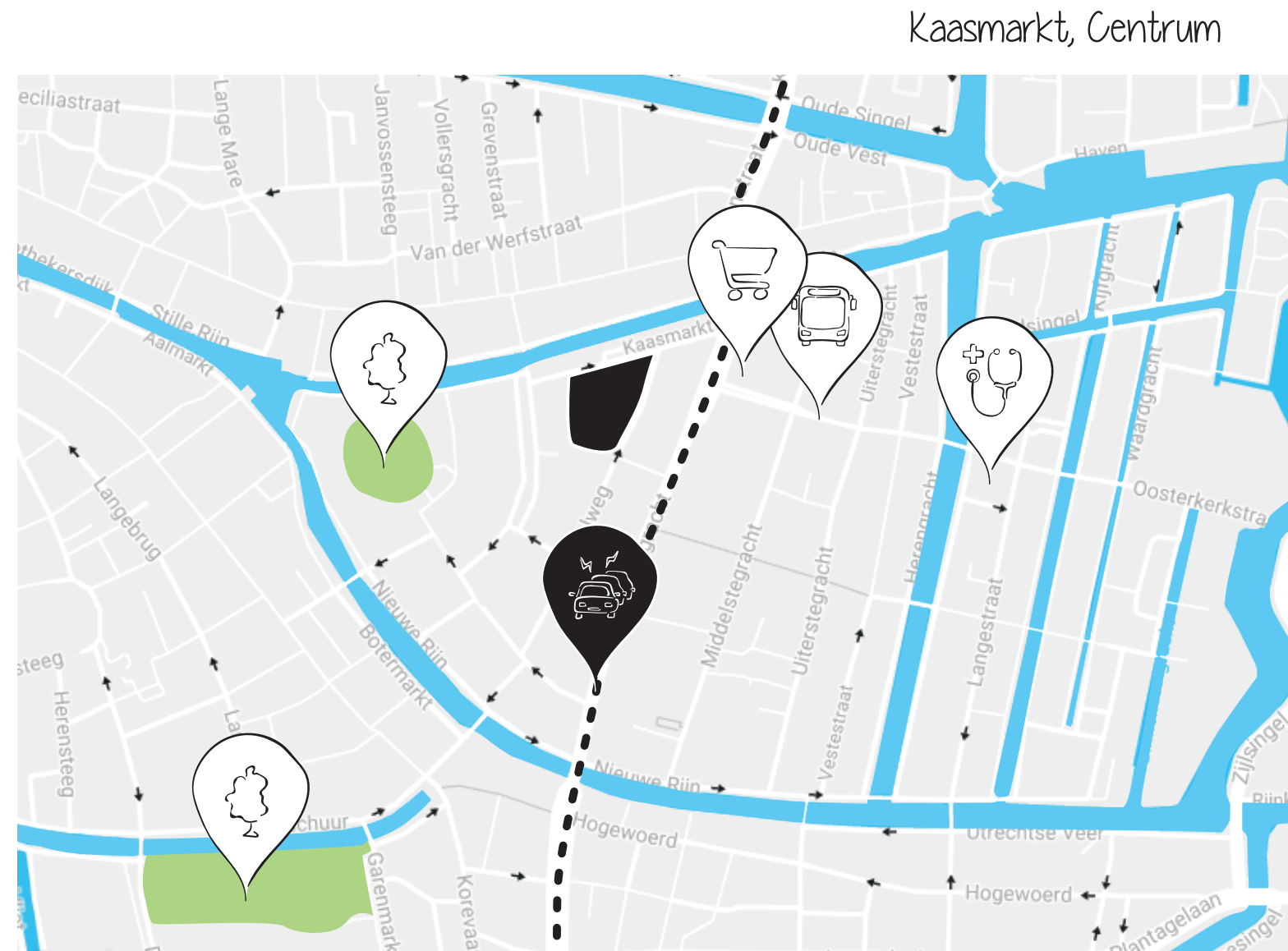
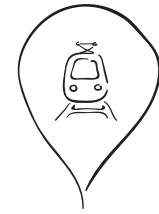

- + Located within city centre
  - + Supermarket is nearby
  - + Bus stop down the street
  - + Train station quite closeby
  - + Not directly next to noisy roads
  - + General practitioner closeby
- City centre can be crowded with people



sound



light



colour

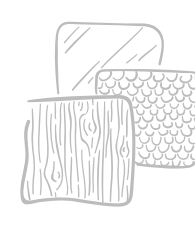

texture



smell



privacy

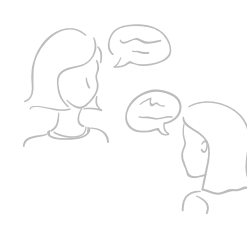

interaction

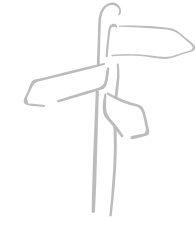

wayfinding

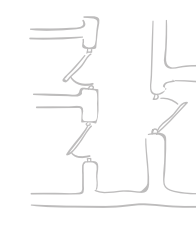

layout



personalisation



nature



comfort



routine

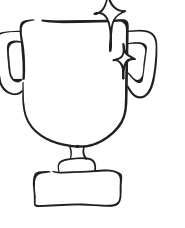

confidence

current state



sound



light



colour

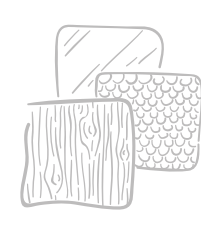

texture



smell



privacy

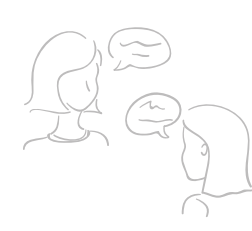

interaction



wayfinding

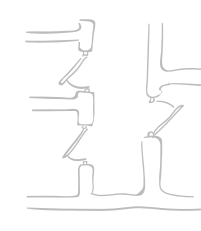

layout

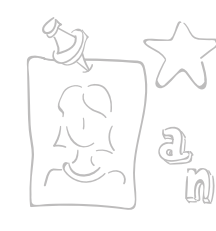

personalisation



nature



comfort



routine



confidence

# *design*

To create a housing building which will ensure a living environment that increases the well-being and independency of people with autism.

Good afternoon,  
my name is Nick.

... and I am Lily, hi!

Hello. I am Lucas,  
nice to meet you.

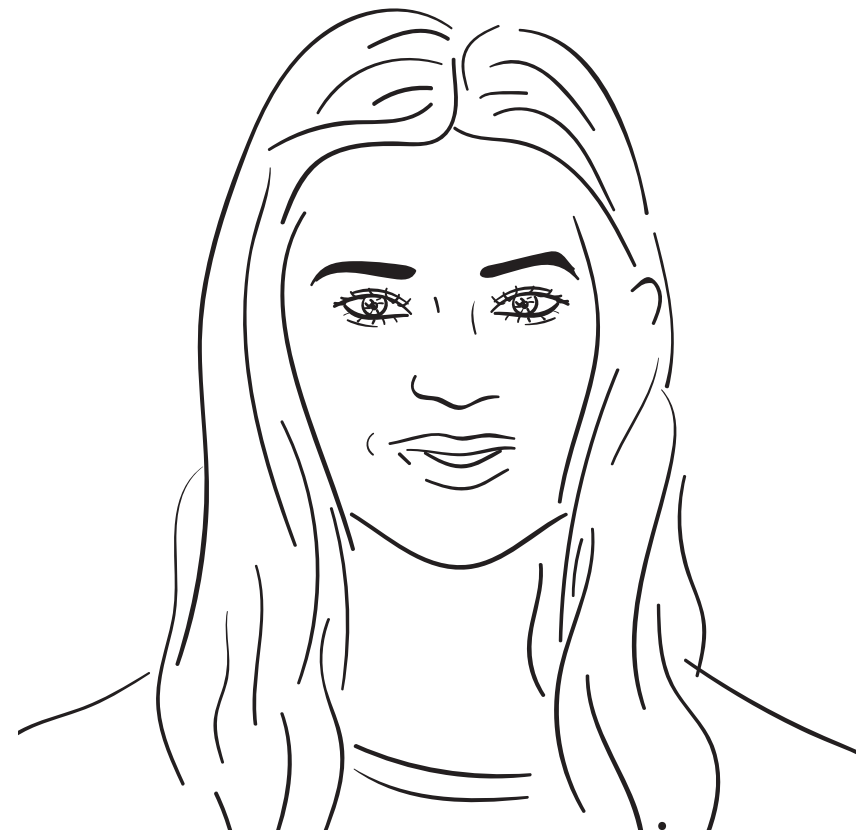

Hi! My name is  
Julia.

Hey! I am Emma,  
fun to see you  
here!

# meet the residents

corresponding profiles - the spiderweb returns

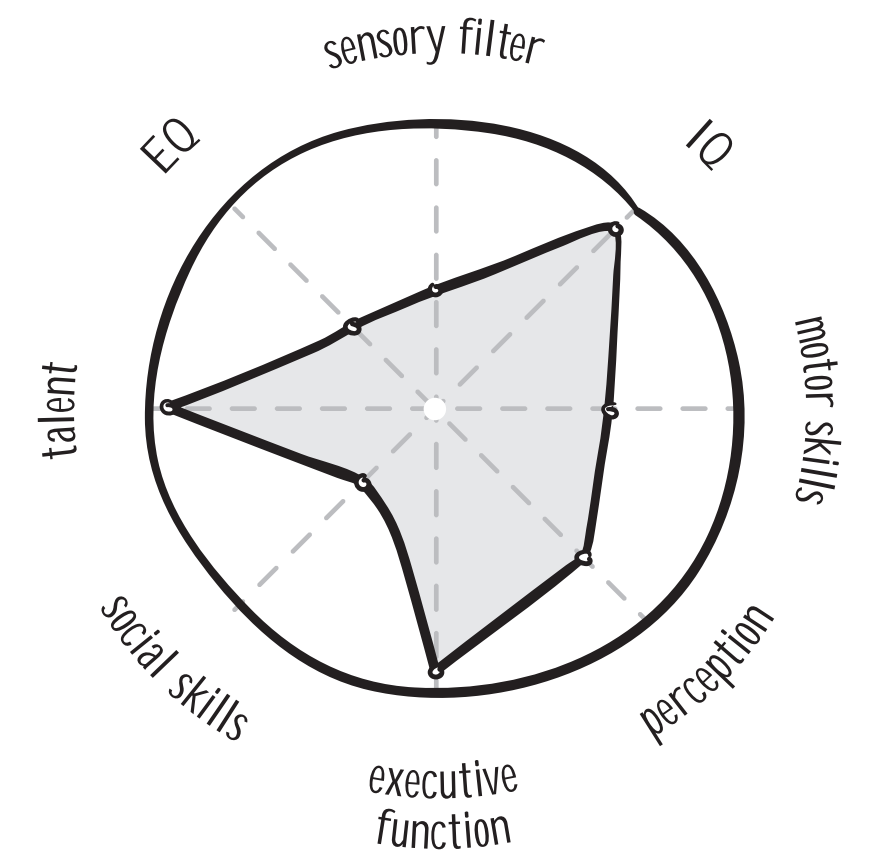
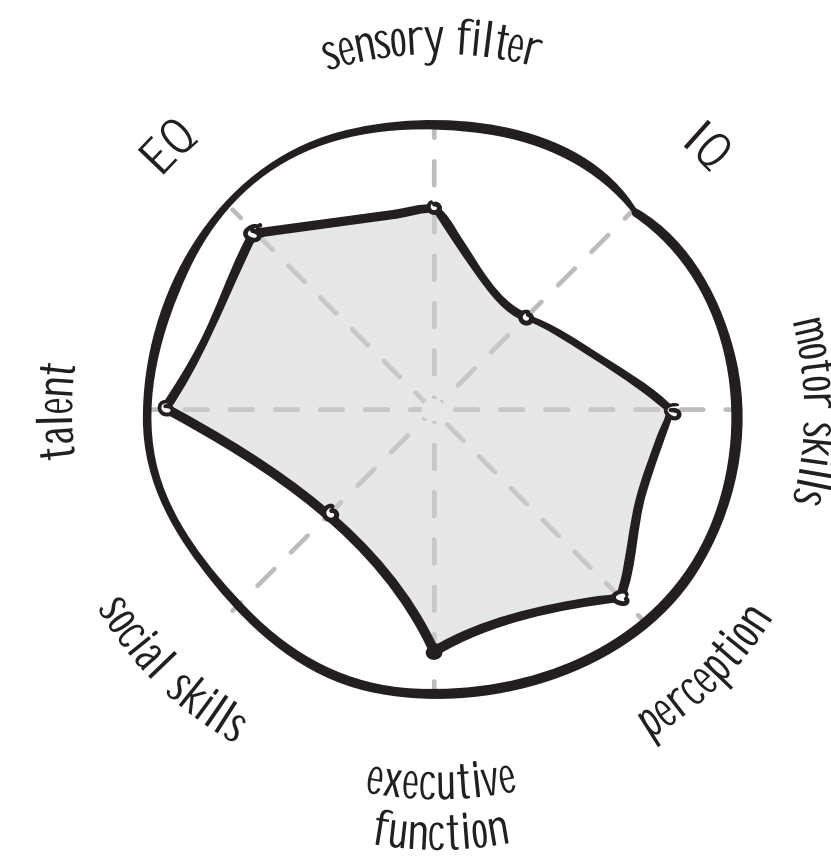
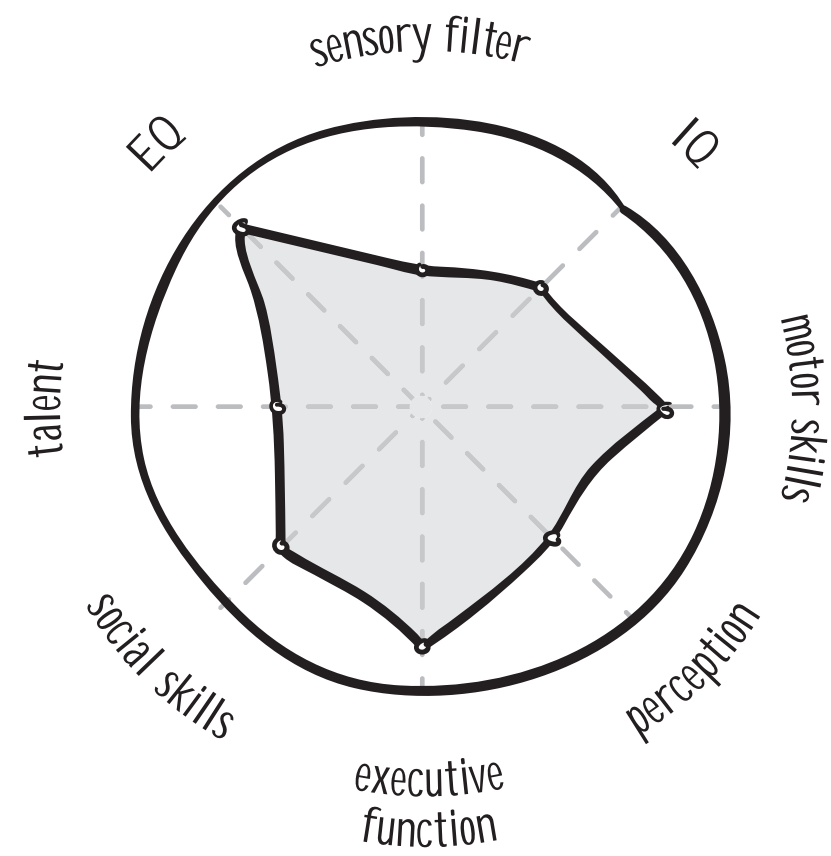
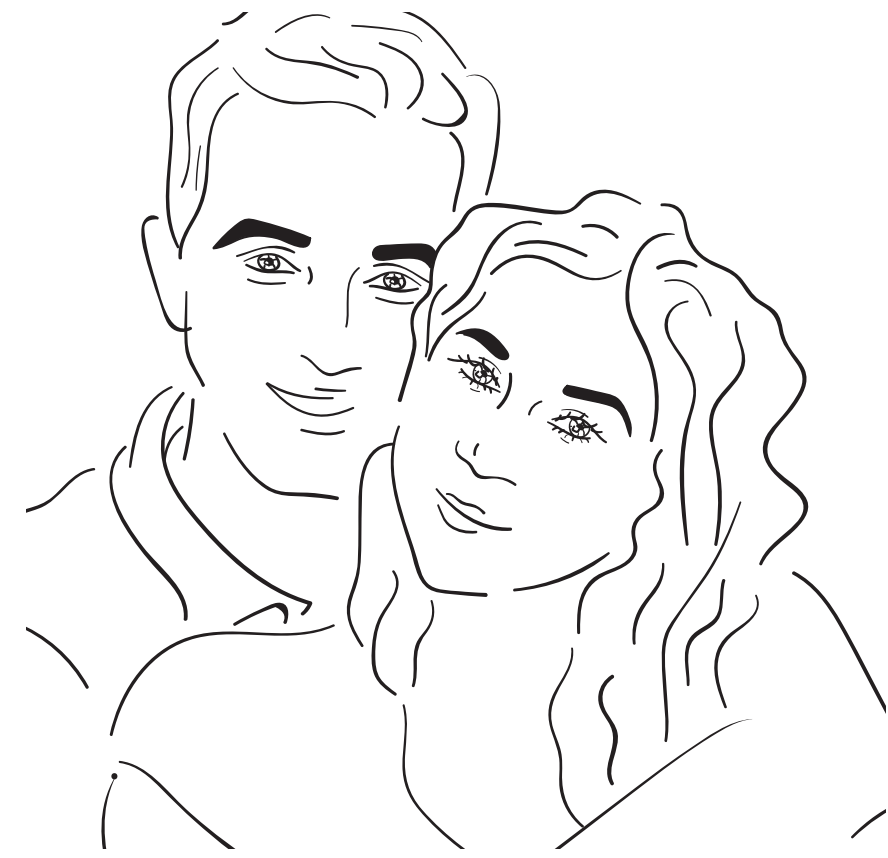
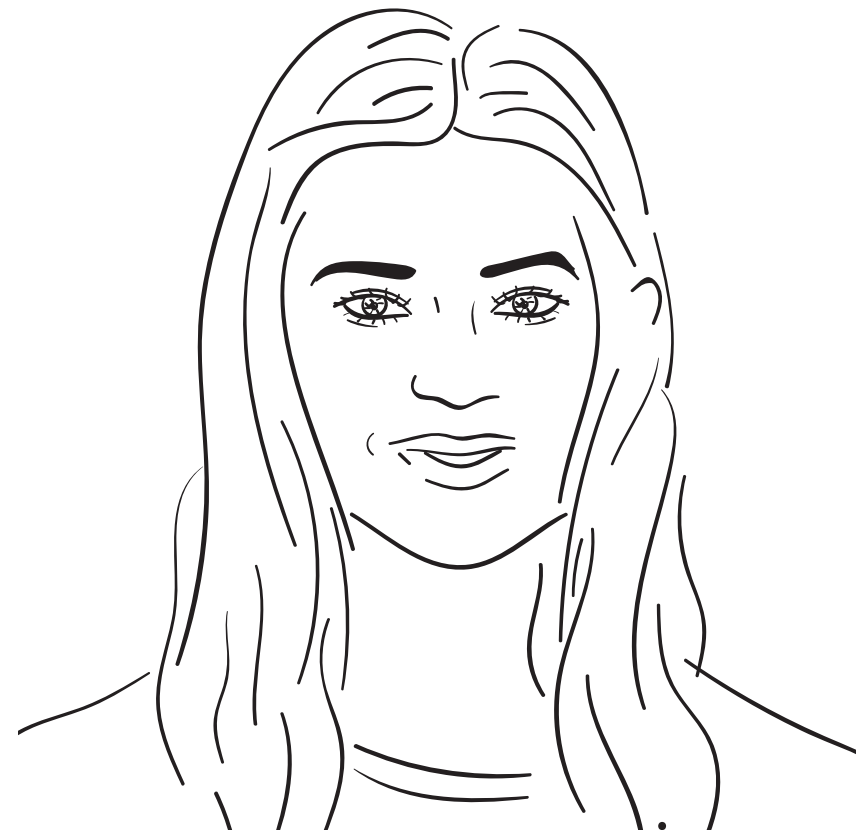

- x decrease sensory load;
- x develop a spatial layout which creates expectations for action ;
- x maximise familiarity and clarity ;
- x create "islands" of privacy throughout building, apartment, and outdoor area ;
- x allow opportunities for social interaction
- x ensure accessibility and inclusion in the surrounding neighbourhood ;
- x allow for a high level of personalisation to enhance identity ;
- x provide control of services like sunshading ;



sound



light

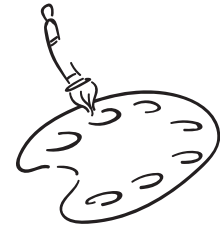

colour

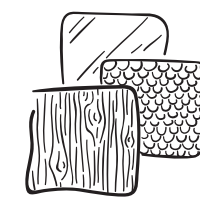

texture



smell



privacy



interaction

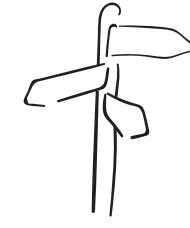

wayfinding

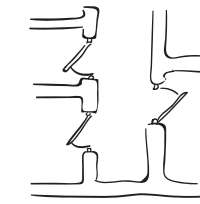

layout



personalisation

nature

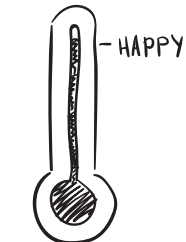

comfort

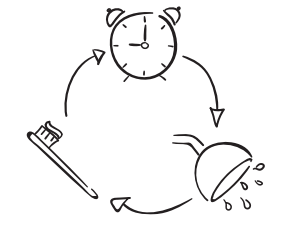

routine



confidence

- x decrease sensory load;
- x develop a spatial layout which creates expectations for action ;
- x maximise familiarity and clarity ;
- x create "islands" of privacy throughout building, apartment, and outdoor area ;
- x allow opportunities for social interaction
- x ensure accessibility and inclusion in the surrounding neighbourhood ;
- x allow for a high level of personalisation to enhance identity ;
- x provide control of services like sunshading ;
- x architecture should work with nature.



sound



light



colour

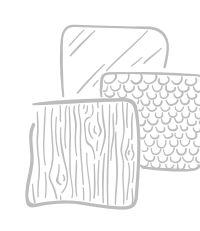

texture



smell



privacy

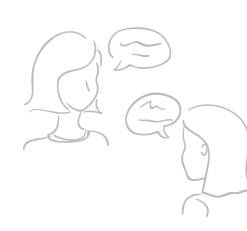

interaction

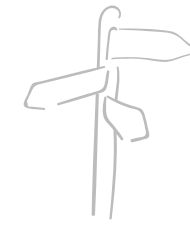

wayfinding

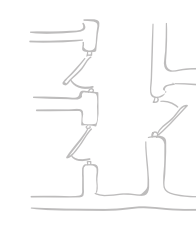

layout



personalisation



nature

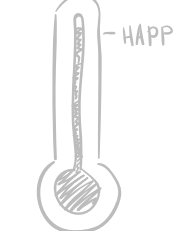

comfort

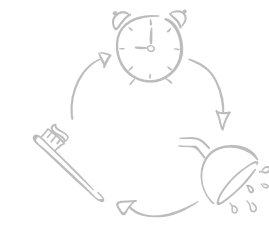

routine



confidence

# program of requirements

as stated during research

- x 15 - 20 apartment units of different sizes, for different needs
- x  $\pm$  60 - 100 m<sup>2</sup> per apartment
- x centrally located common room for meeting and eating
  
- x create a sensory private garden
- x create a surrounding green area of which the neighbourhood can benefit as well
- x provide flexible choice in apartment layout
- x to add a public function like a lunch room or coffee bar which will be run by (some of the) residents



sound



light

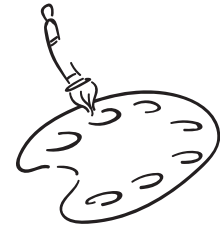

colour

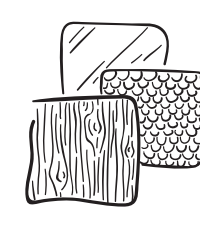

texture



smell



privacy

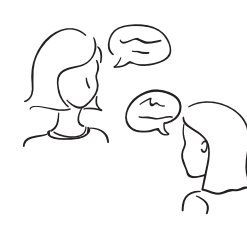

interaction

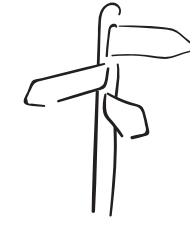

wayfinding

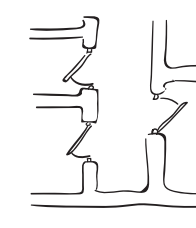

layout



personalisation



nature

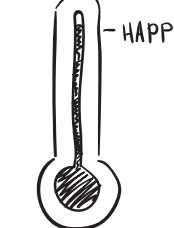

comfort

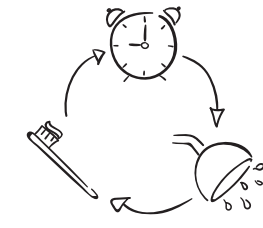

routine



confidence



# the Dutch little courtyard - 'het hofje'



- x tranquil places located centrally in the city
- x not only the buildings are important, emphasis also lies on the (green) courtyard
- x creates a feeling of privacy in a busy city
- x increases feeling of collectivity and "togetherness"



sound



light



colour

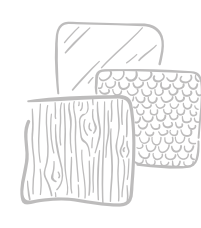

texture



smell



privacy

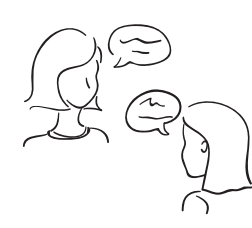

interaction

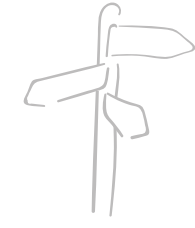

wayfinding

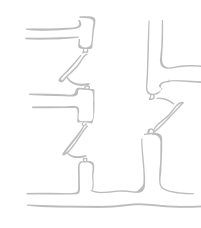

layout



personalisation



nature



comfort



routine



confidence

Julia

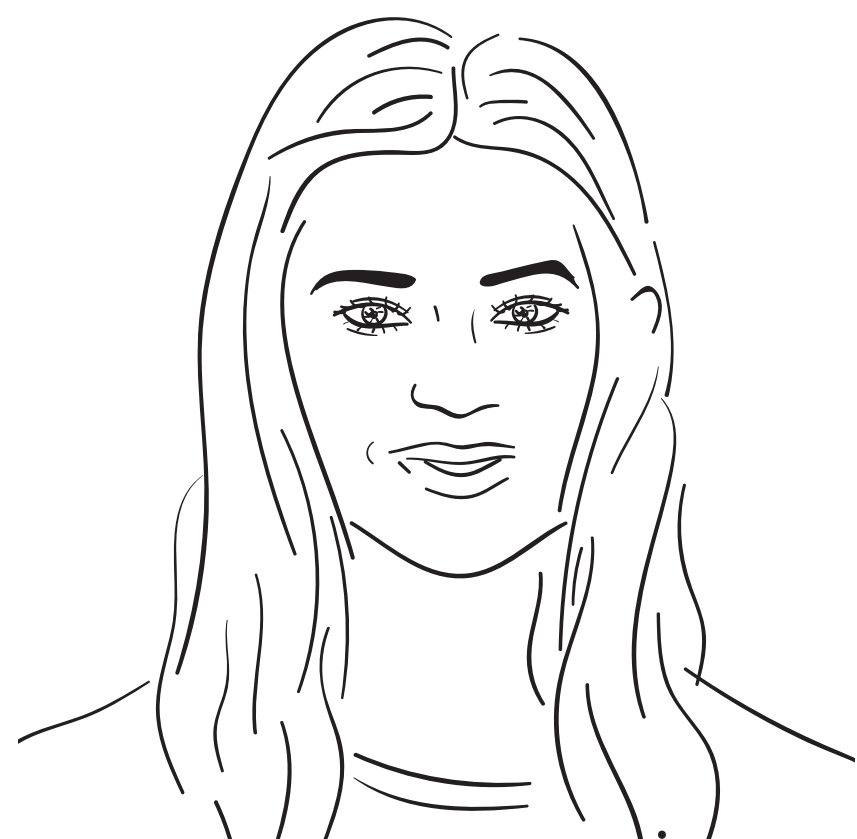

Nick and Lily

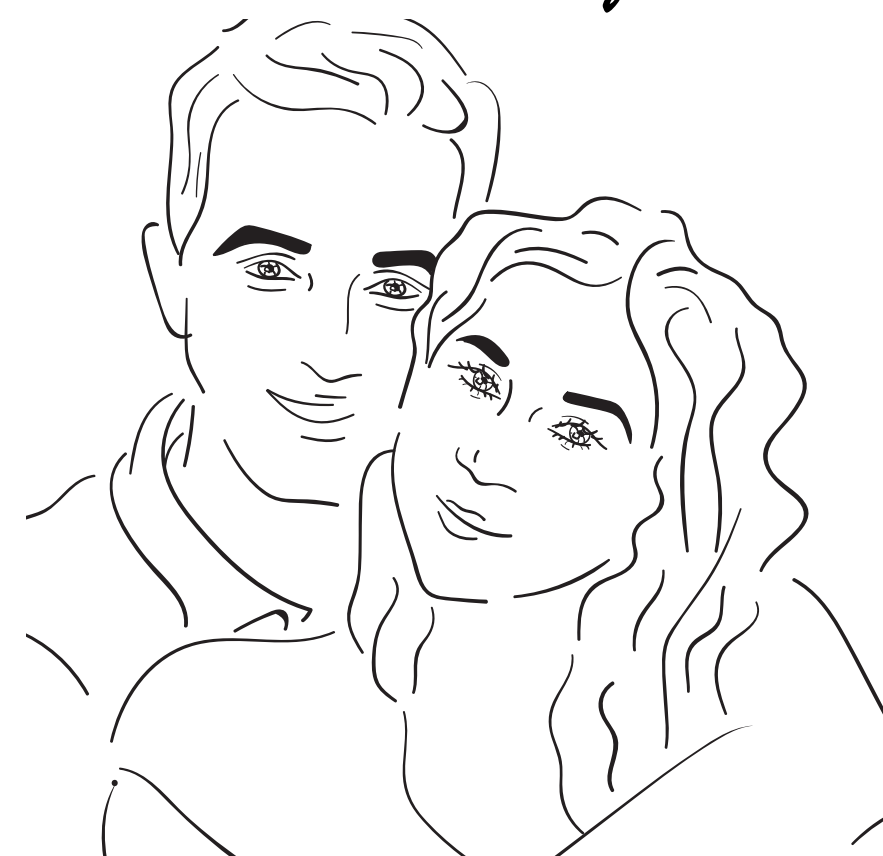

Emma



Lucas



sound



light



colour

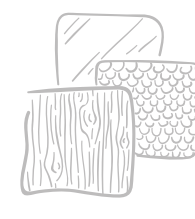

texture



smell



privacy



interaction

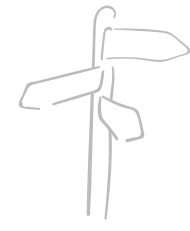

wayfinding



layout



personalisation



nature

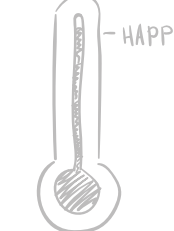

comfort

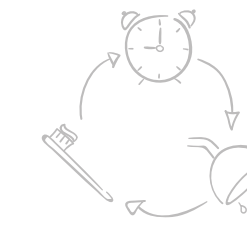

routine



confidence

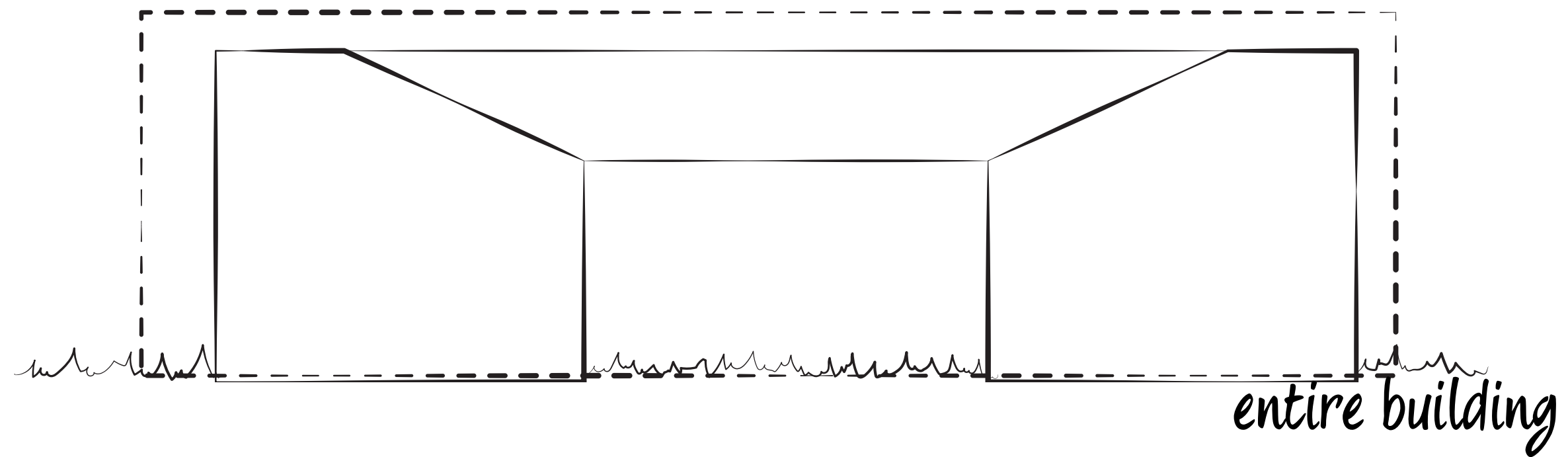

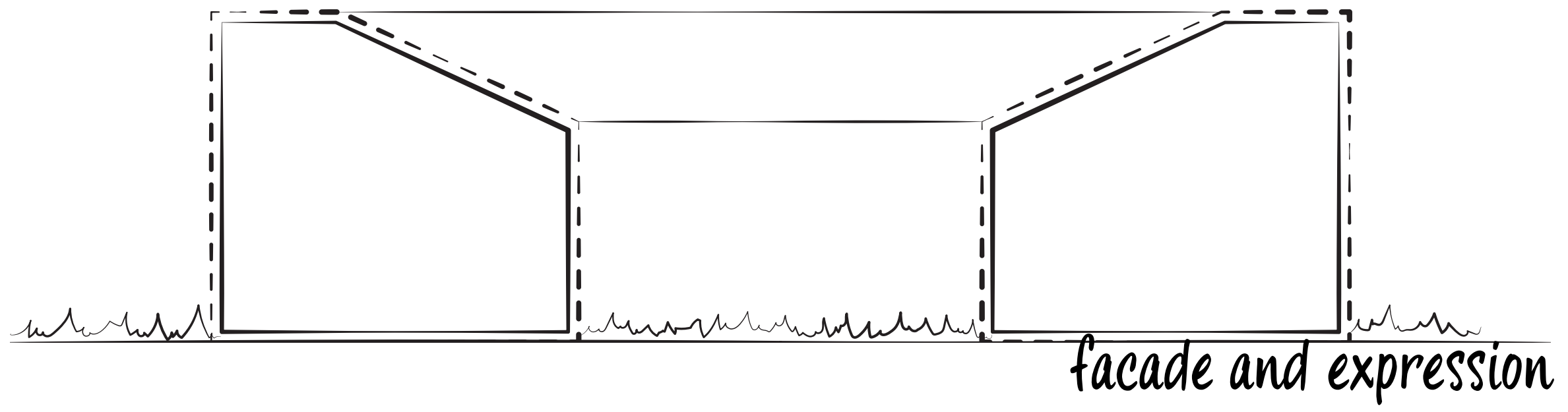
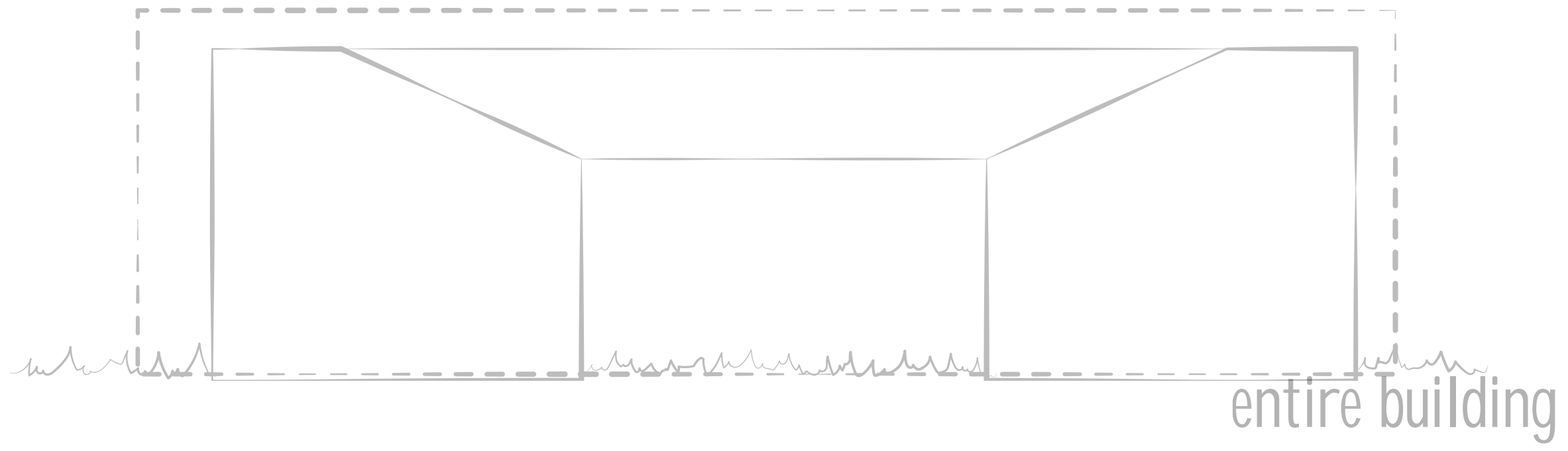

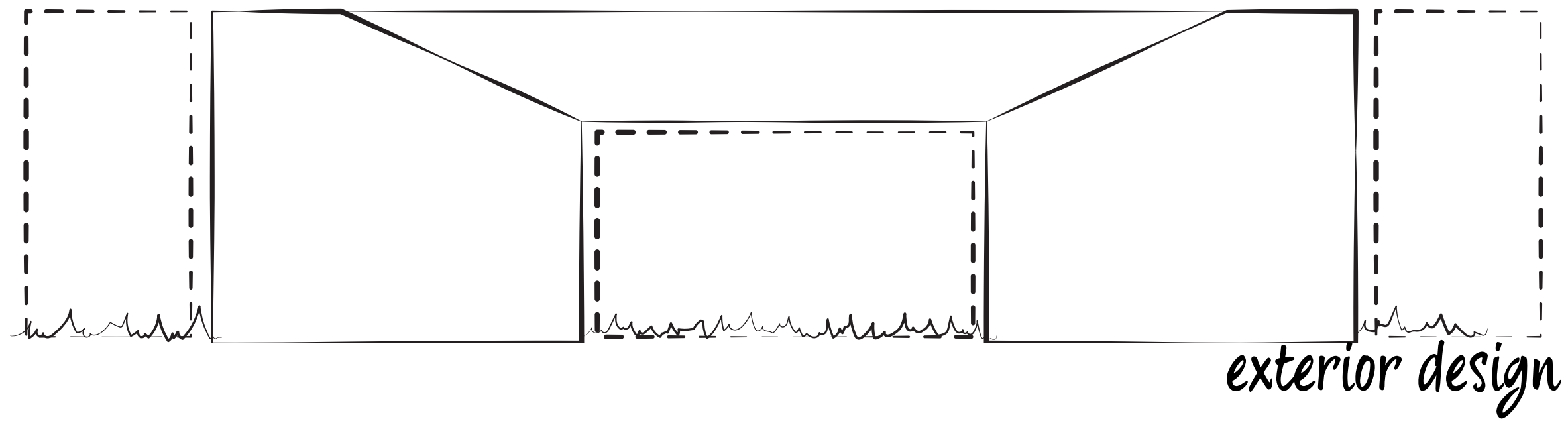
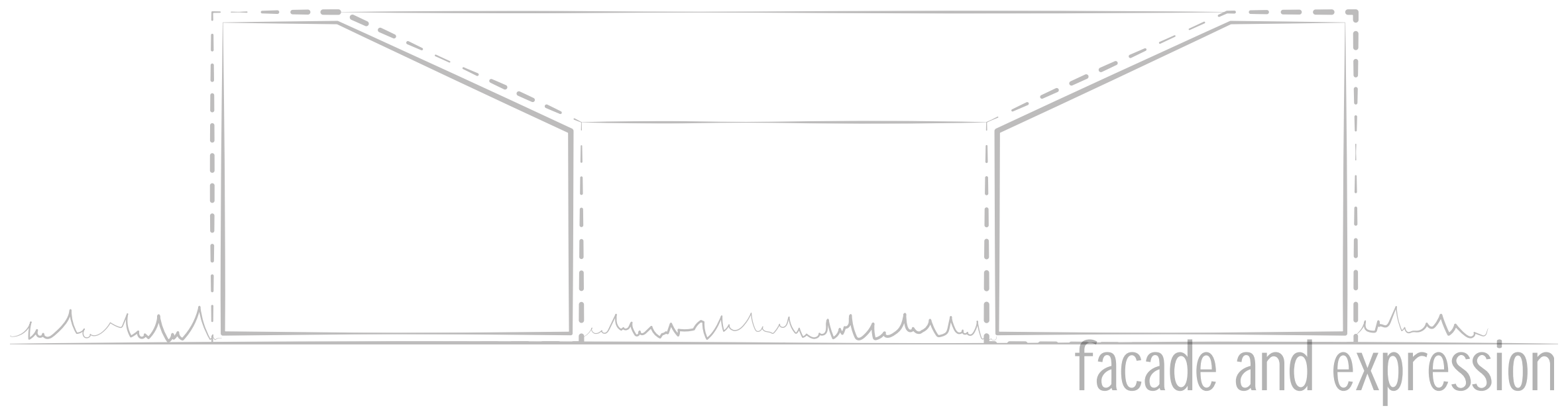
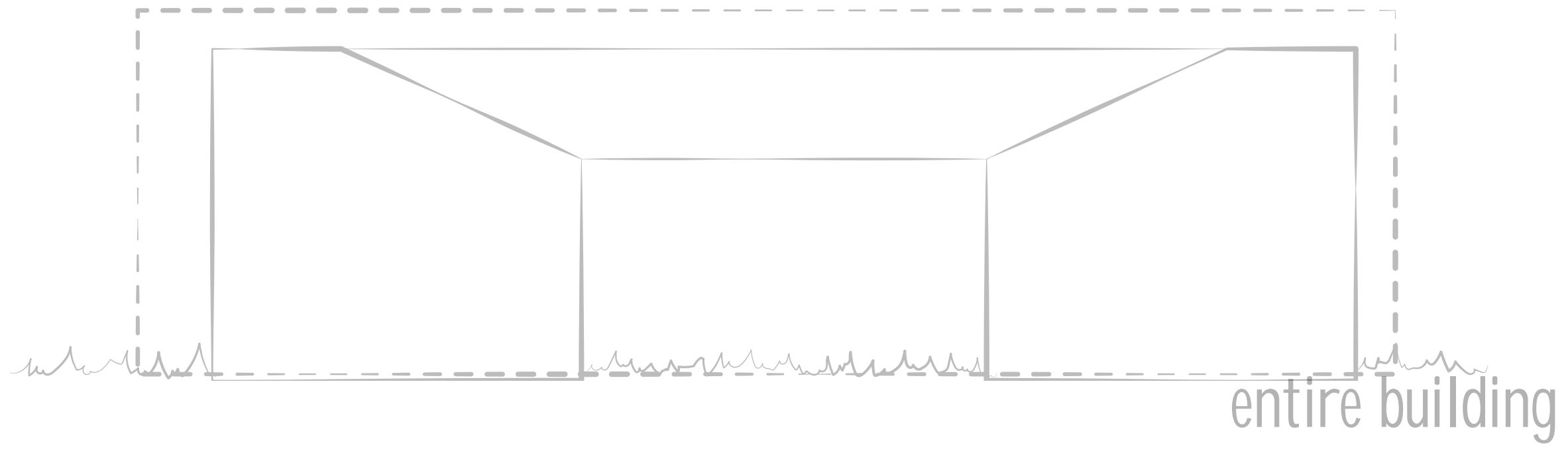

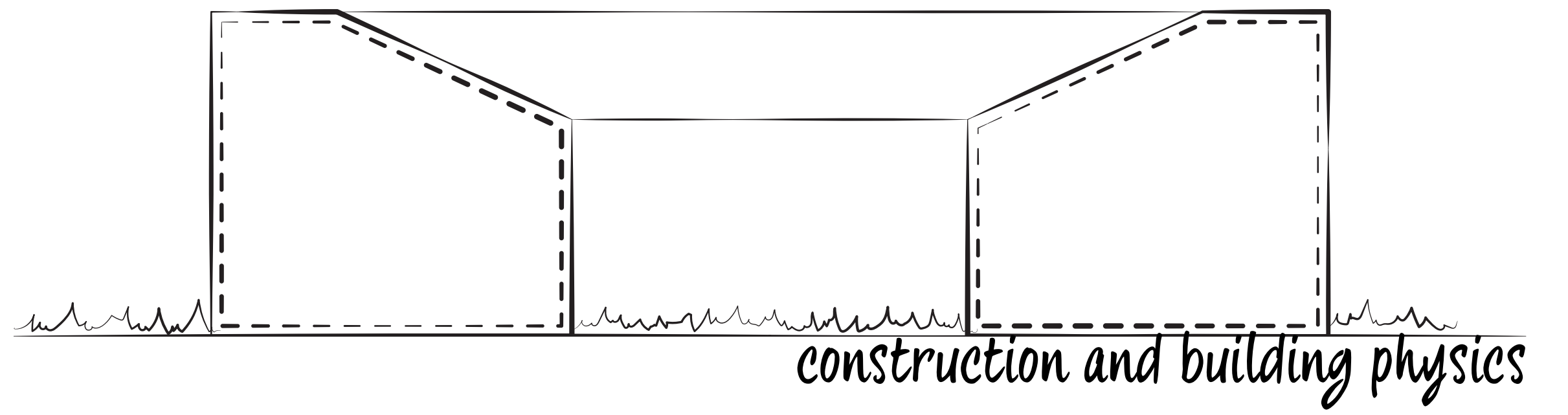
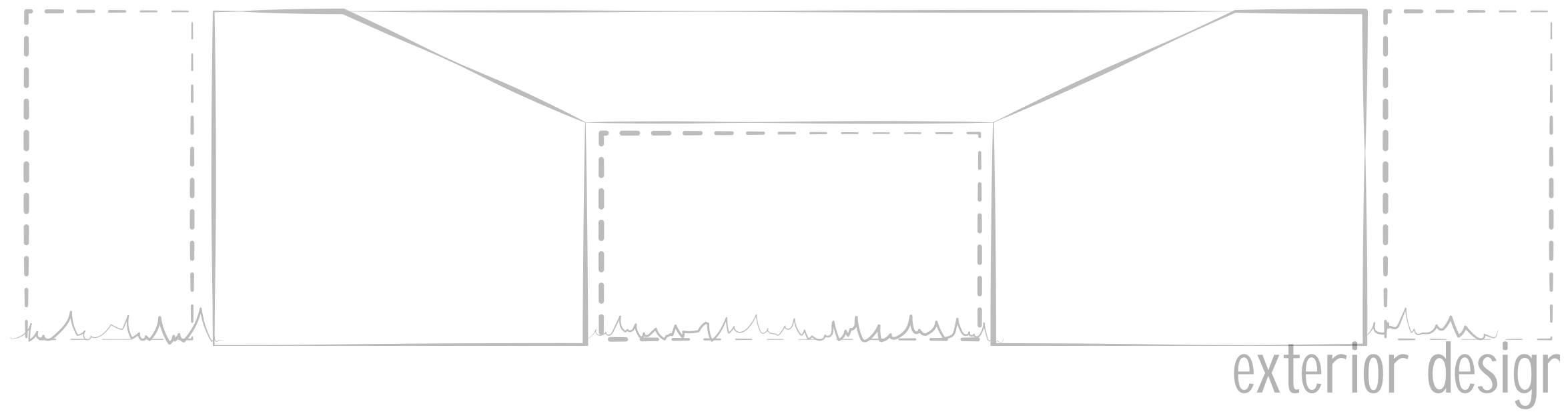
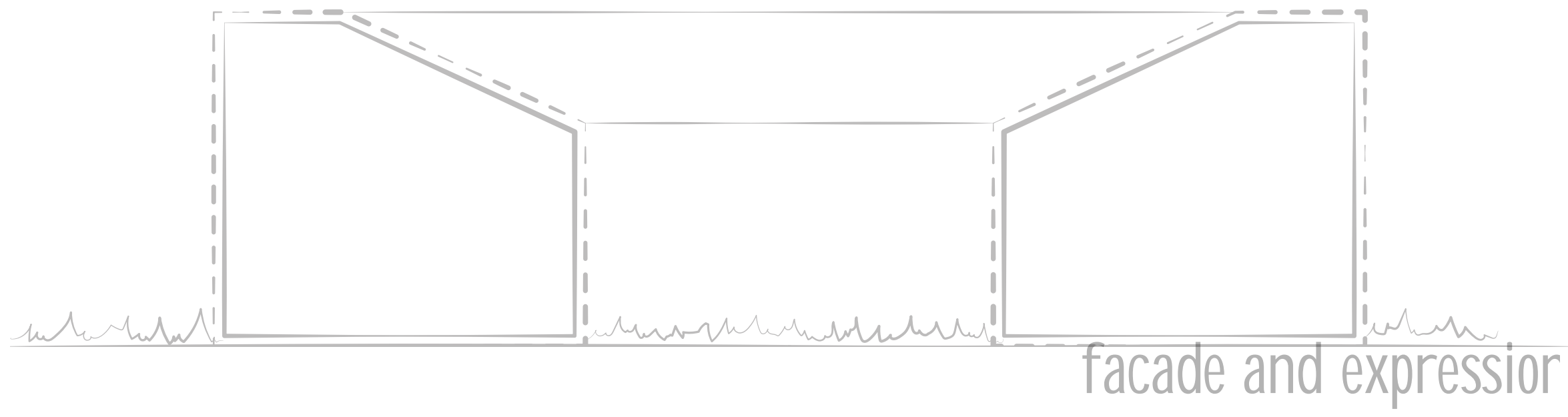
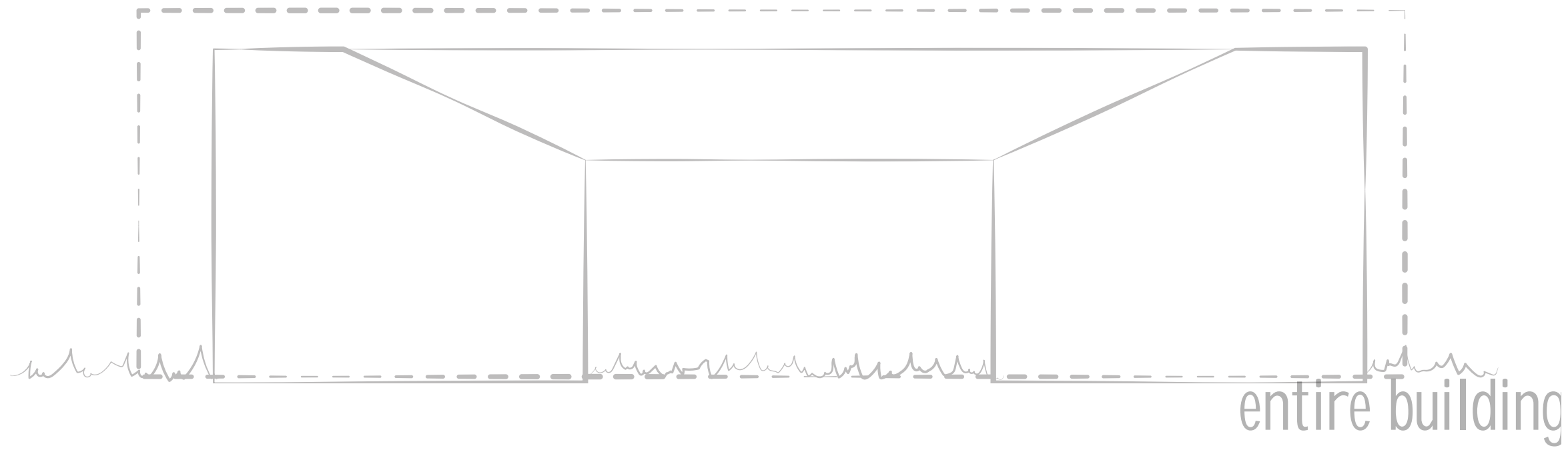

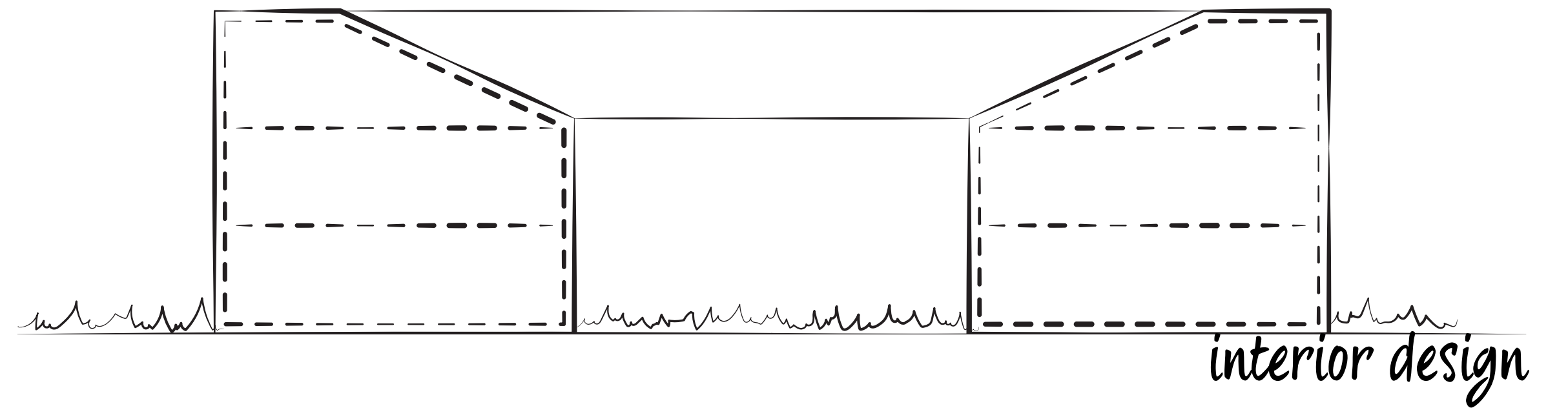
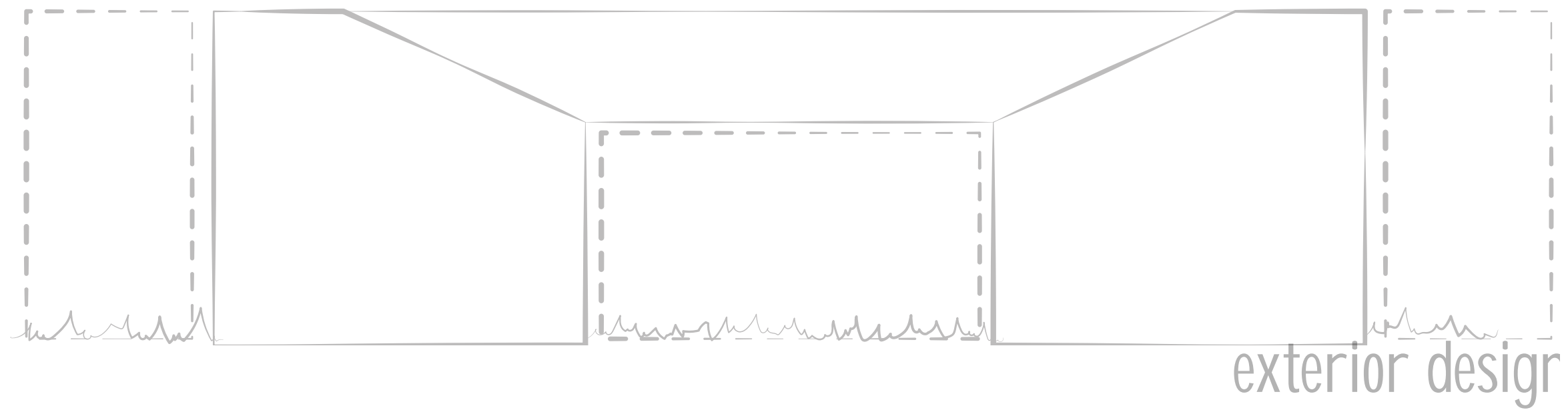
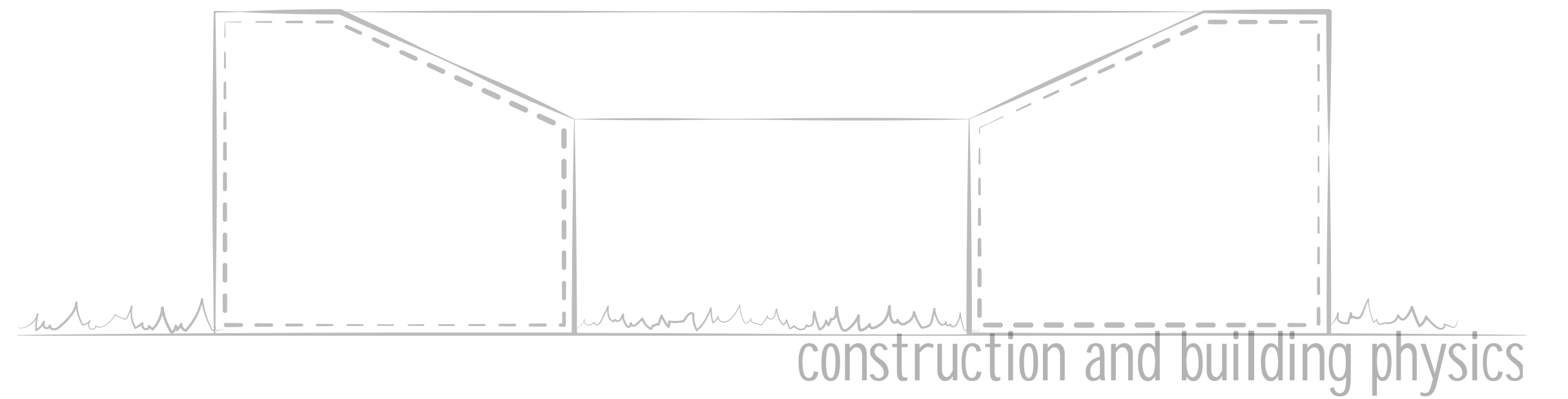
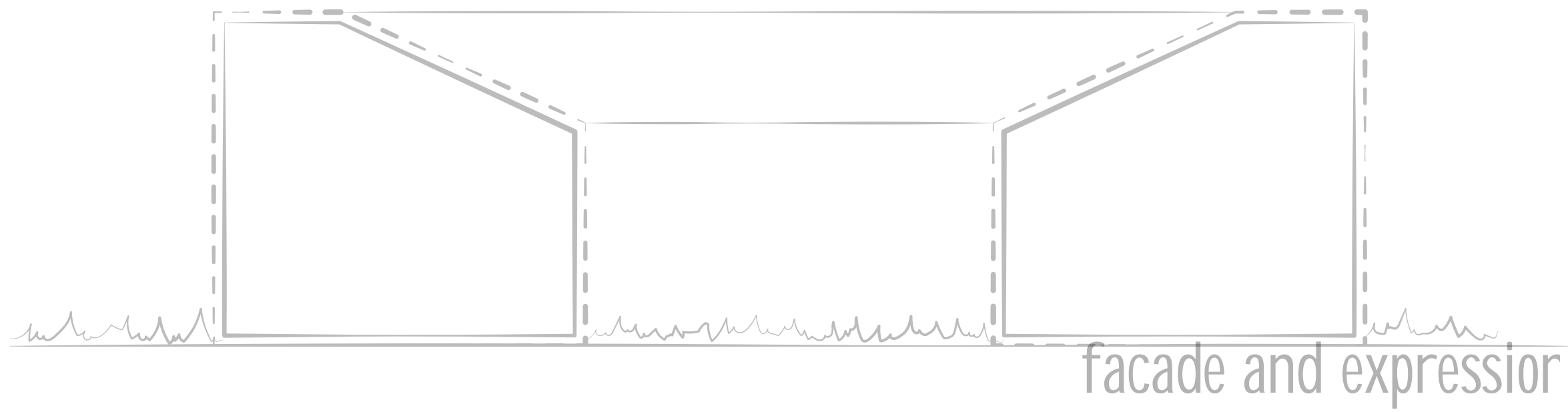
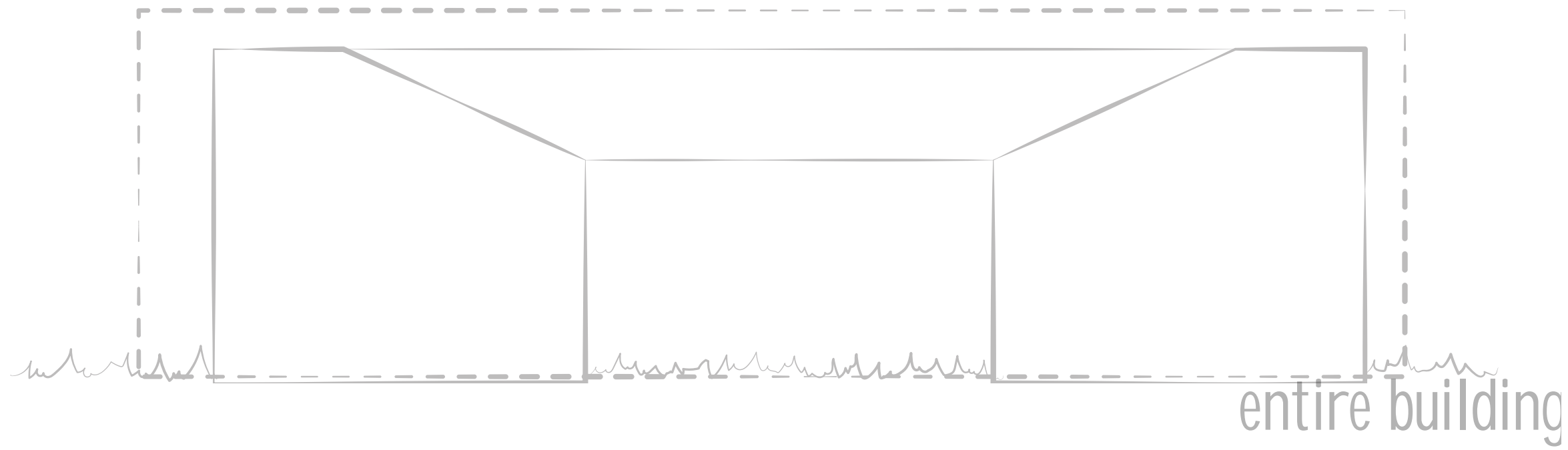

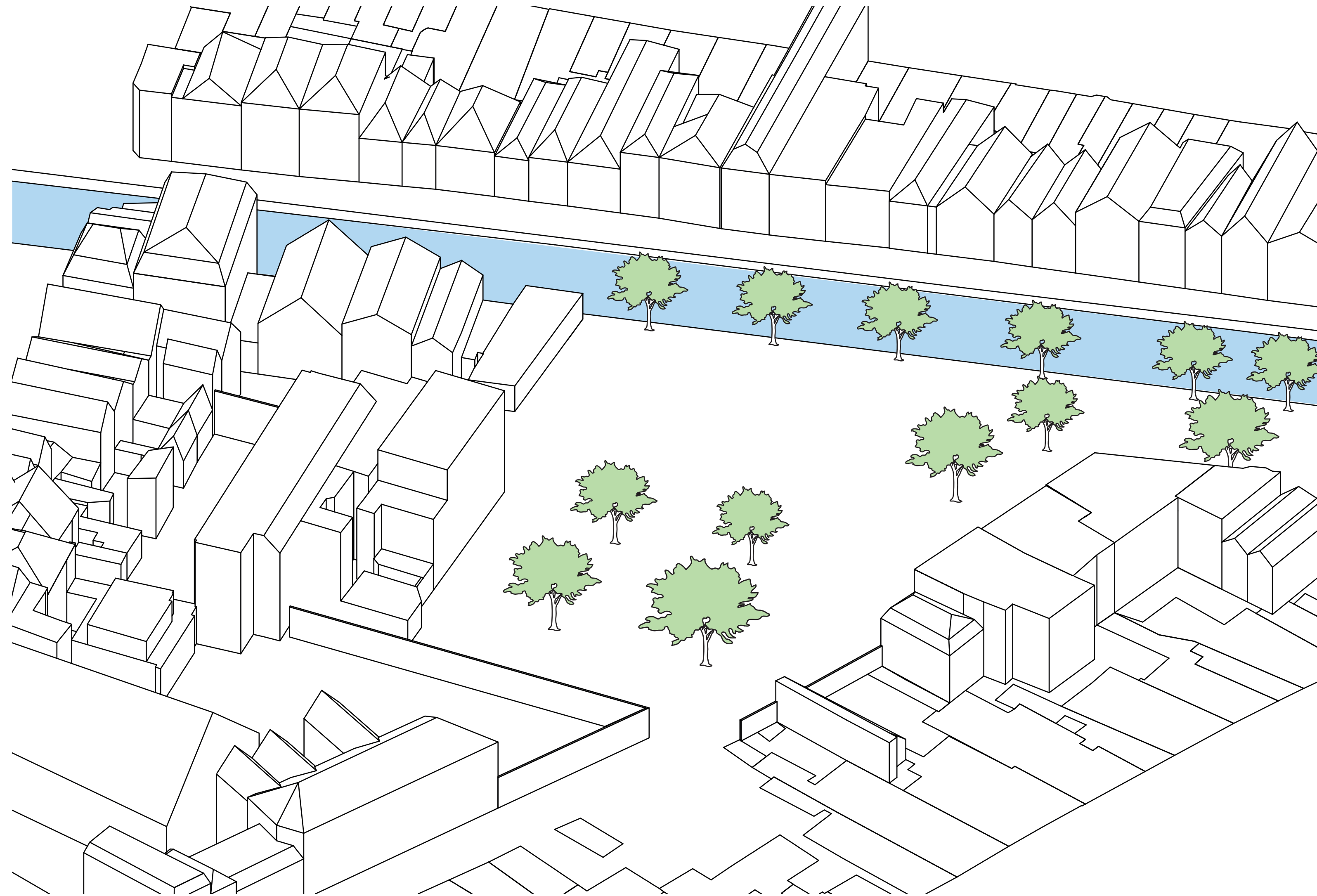

this is the plot,  
with contains  
multiple sycamore  
trees.



sound



light



colour

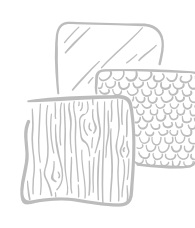

texture



smell



privacy



interaction

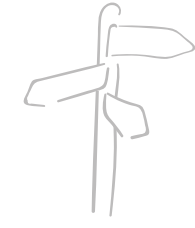

wayfinding

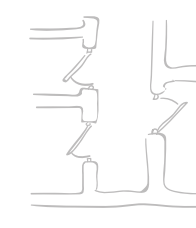

layout



personalisation



nature

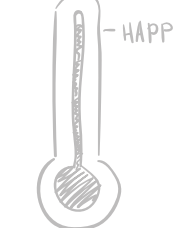

comfort



routine

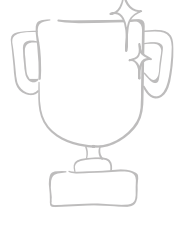

confidence



those trees were very important ...

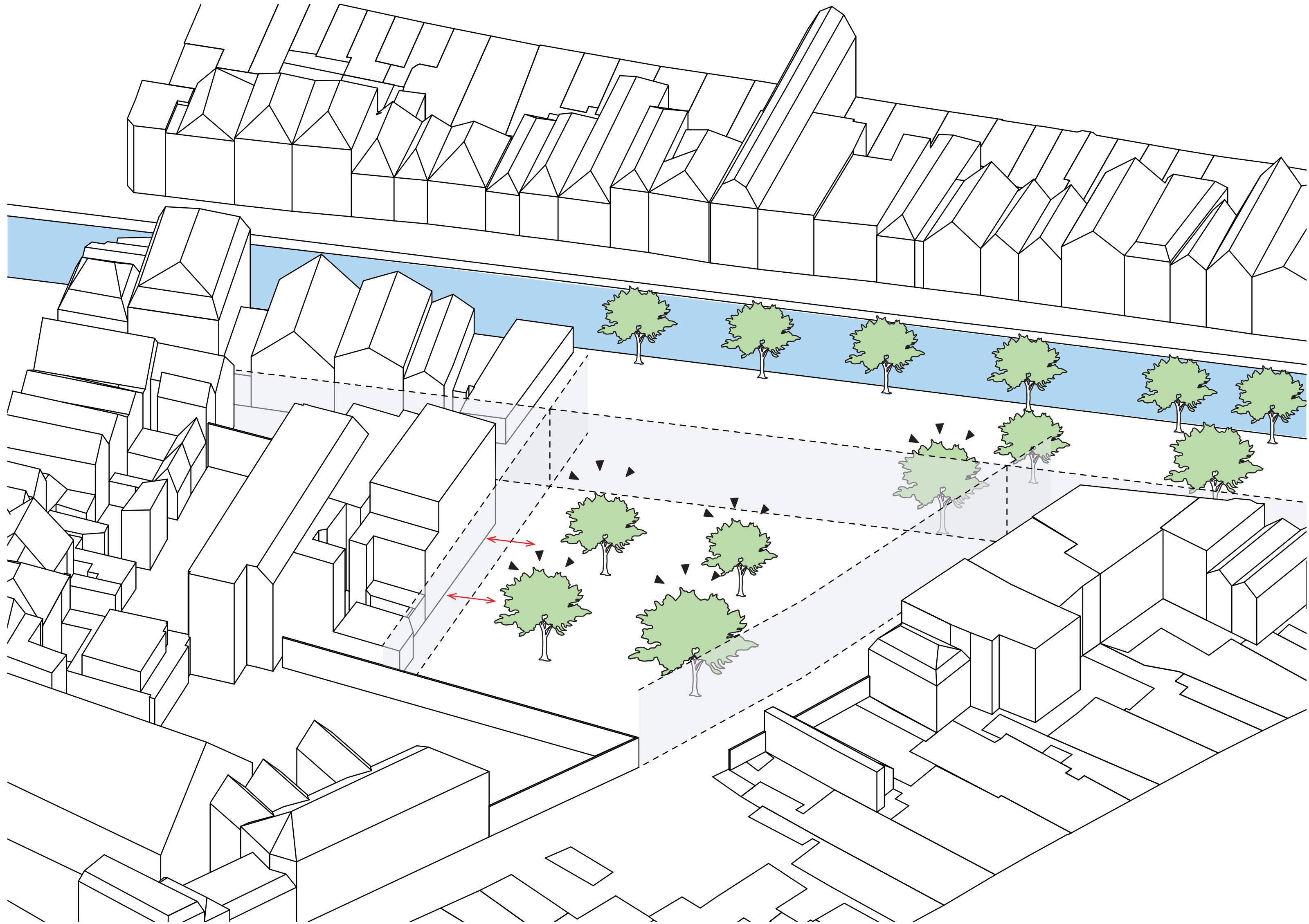

... as well as finishing existing lines ...

... and don't forget the connection with the school building!

- sound
- light
- colour
- texture
- smell
- privacy
- interaction
- wayfinding
- layout
- personalisation
- nature
- comfort
- routine
- confidence

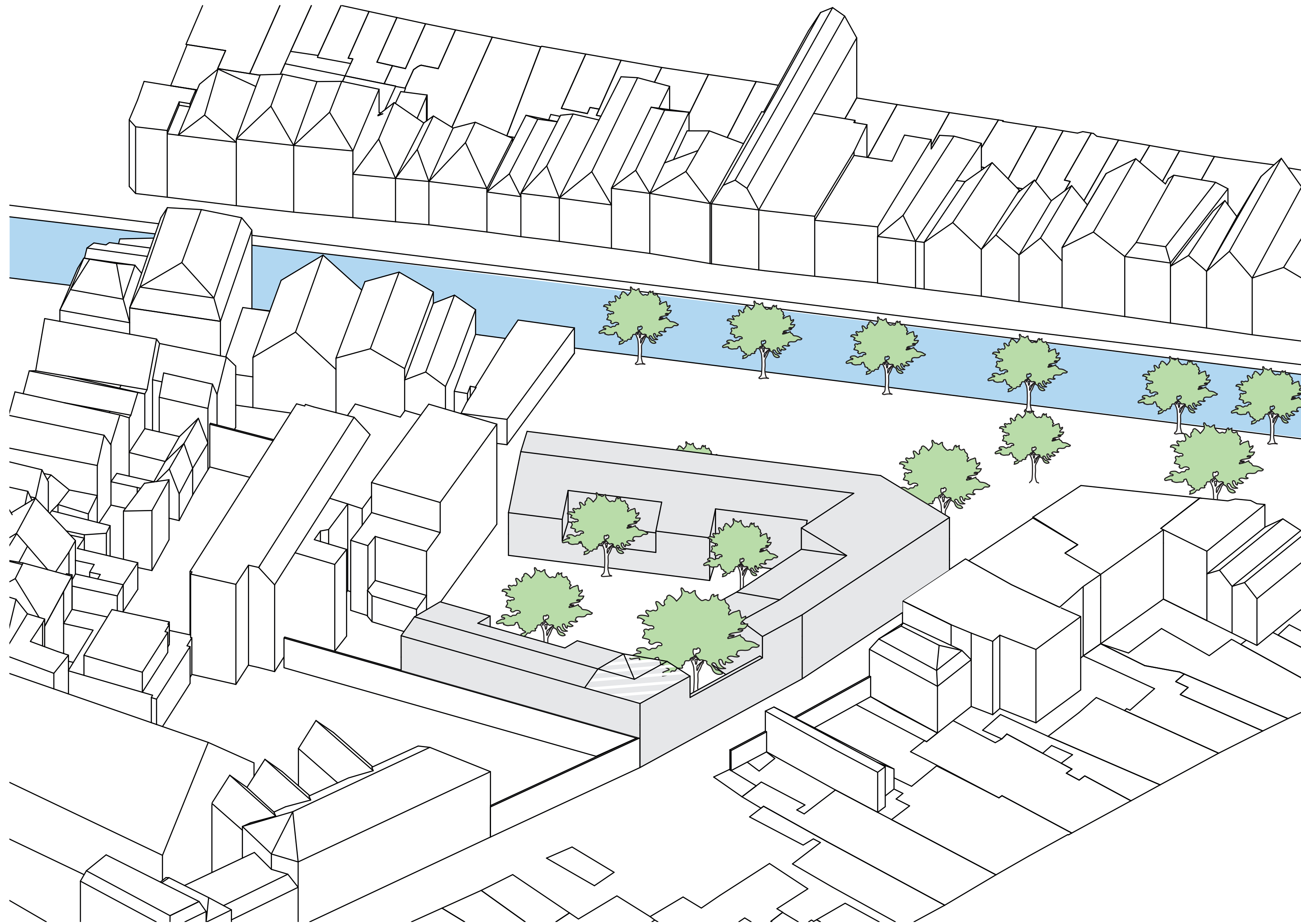

and this is the result!

The building consists of three building layers on the city side, while the courtyard side has only two, so it doesn't seem as intimidating



sound



light



colour

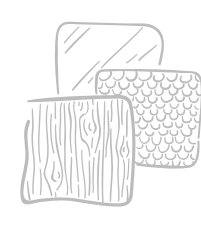

texture



smell



privacy

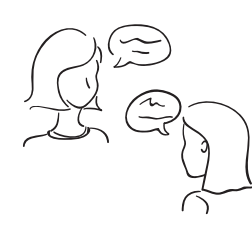

interaction

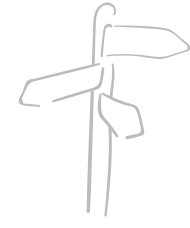

wayfinding

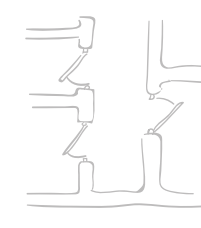

layout



personalisation



nature



comfort



routine



confidence

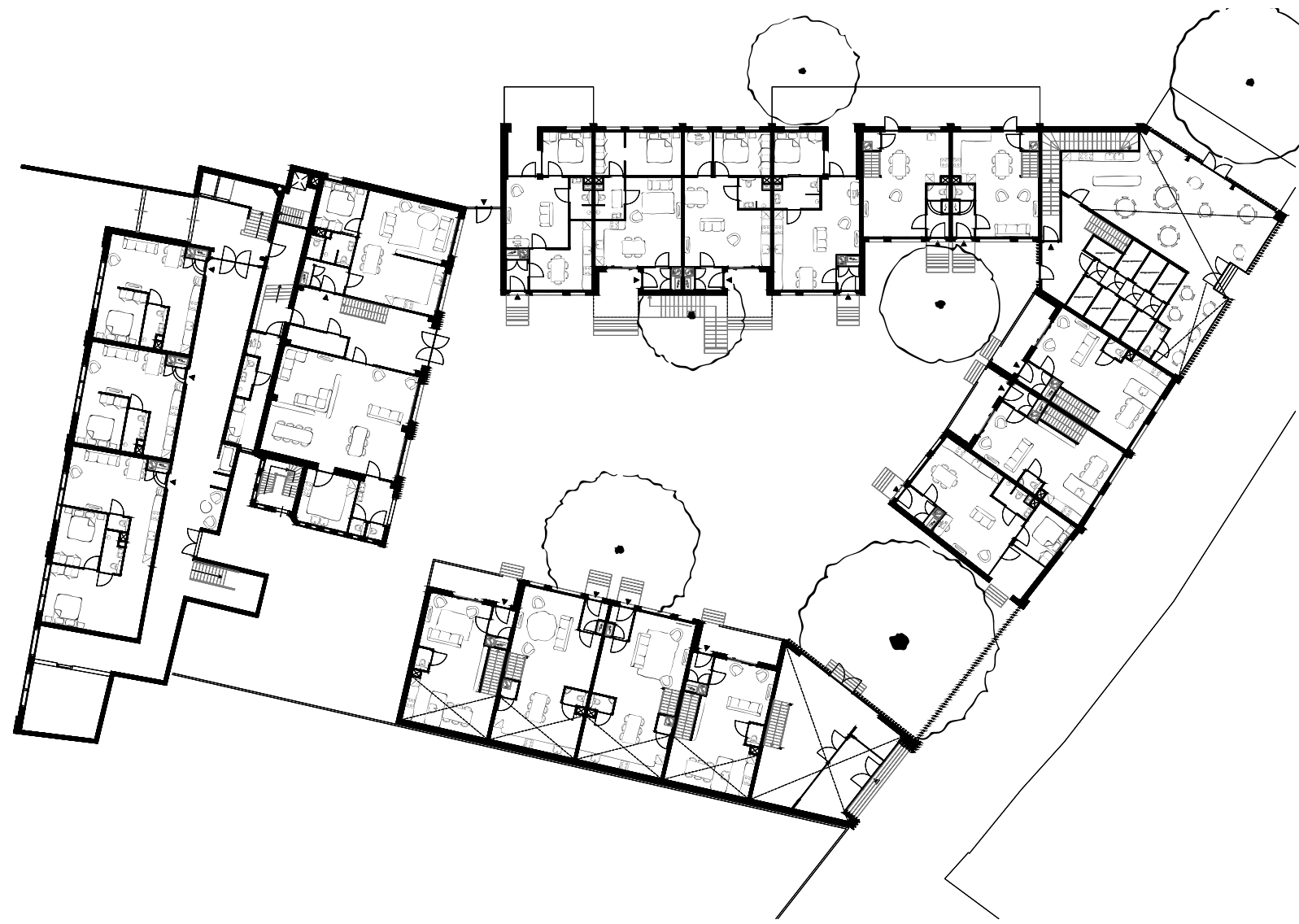

ground floor

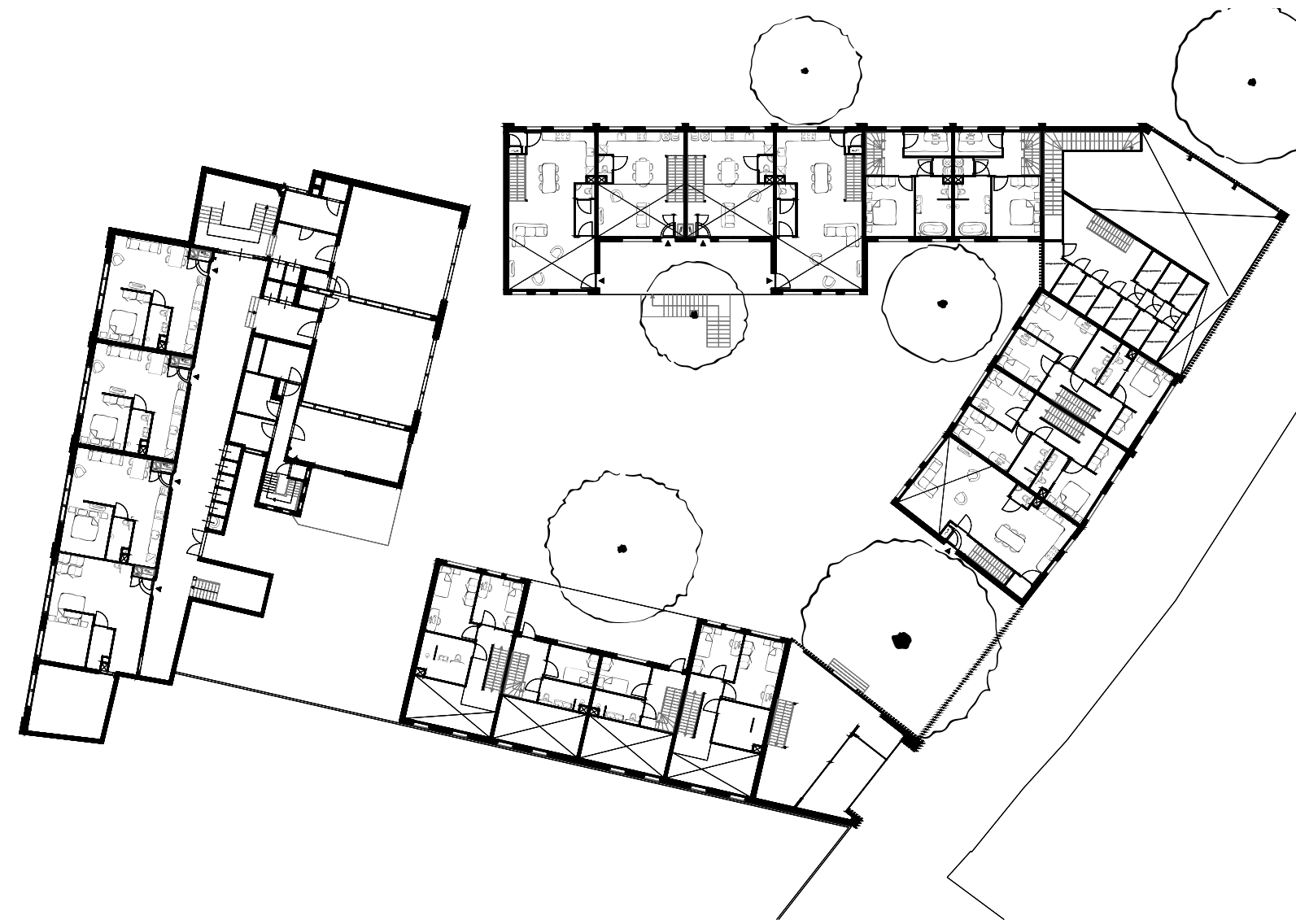

first floor

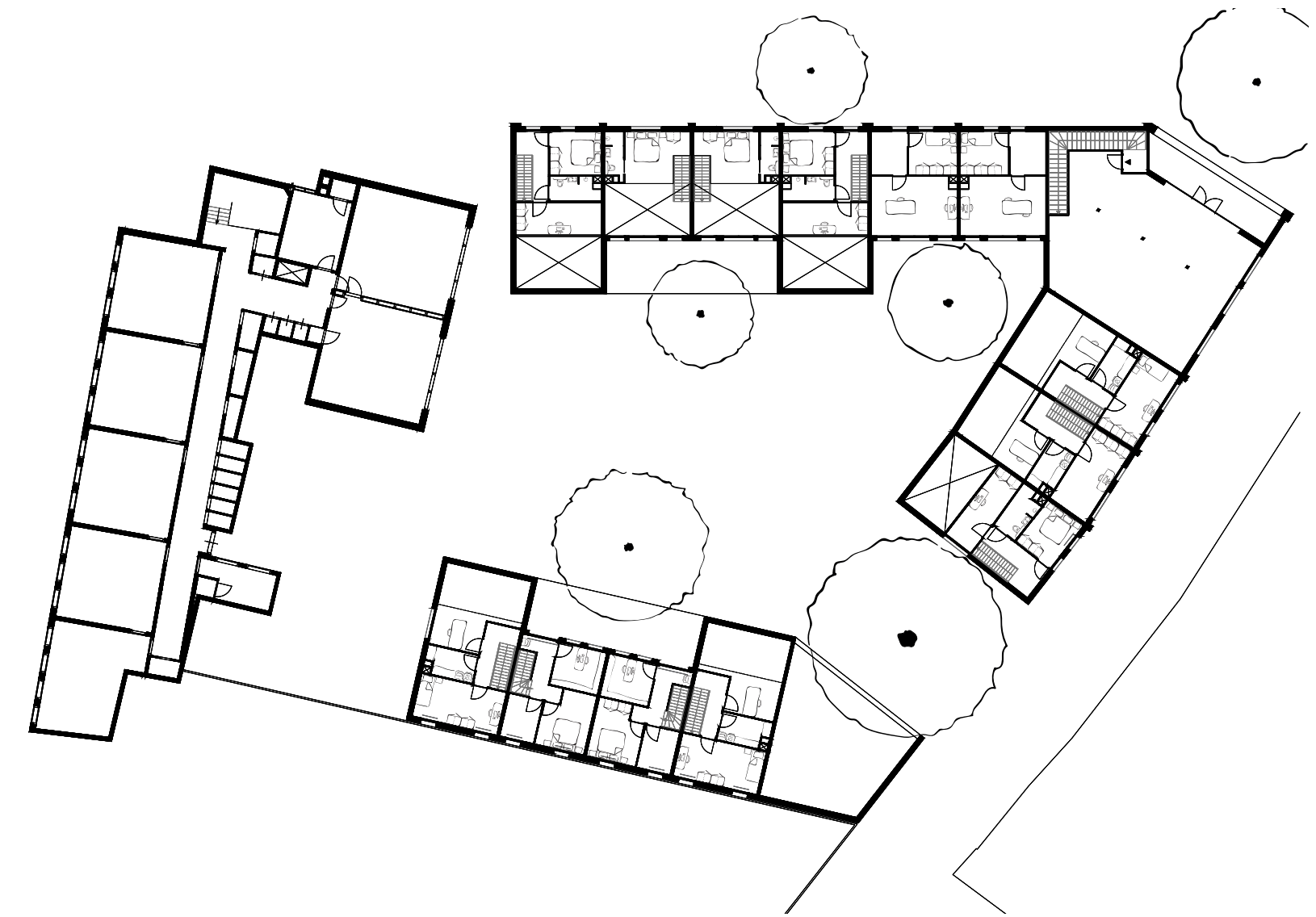

second floor



sound



light



colour



texture



smell



privacy



interaction



wayfinding

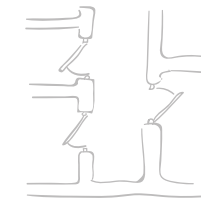

layout



personalisation



nature



comfort



routine



confidence



ground floor



first floor

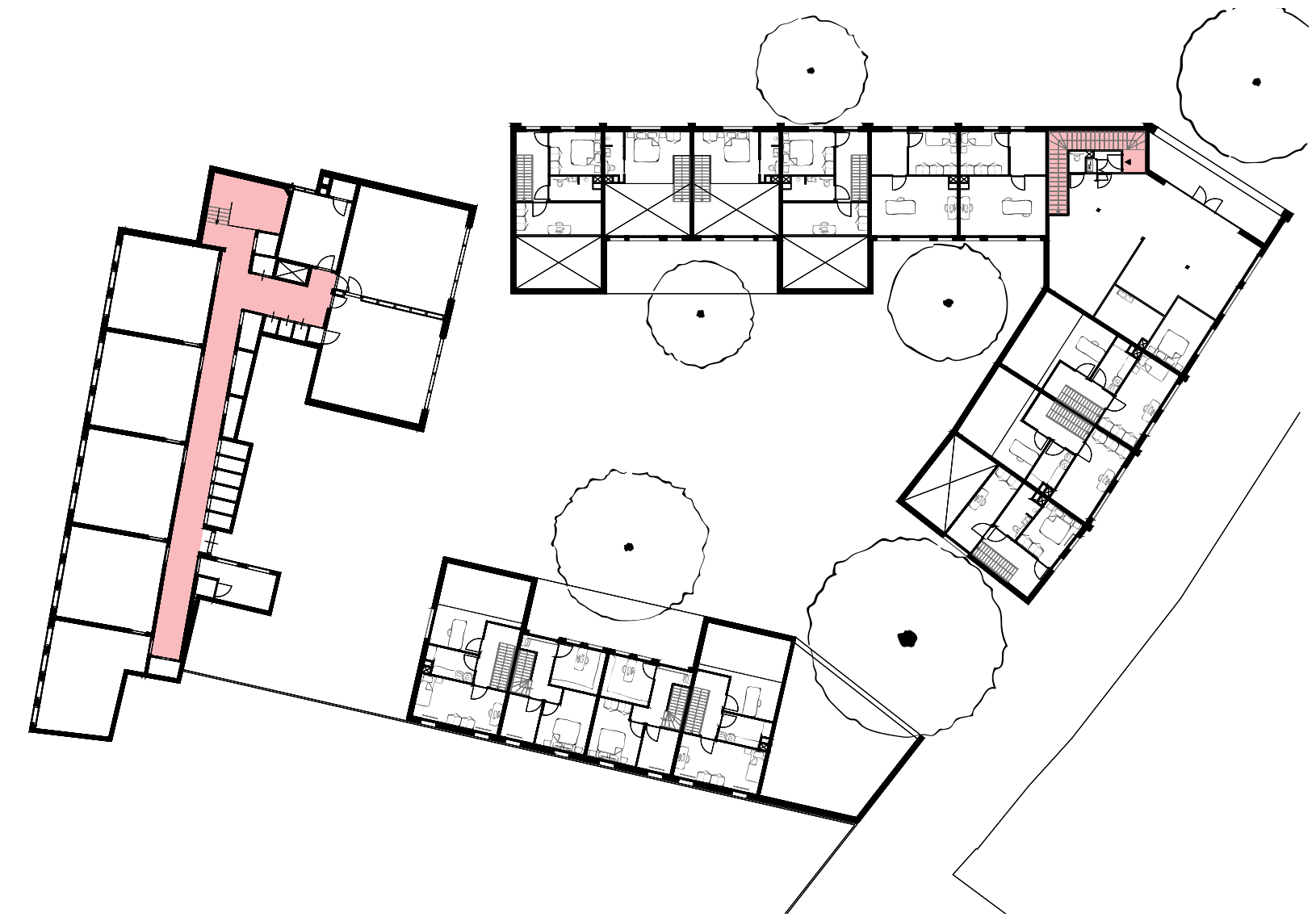

second floor



sound



light



colour

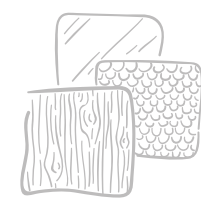

texture



smell



privacy



interaction

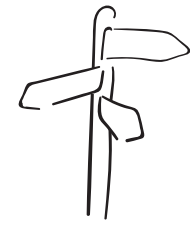

wayfinding

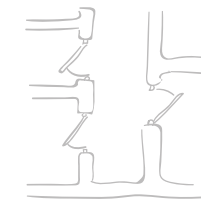

layout

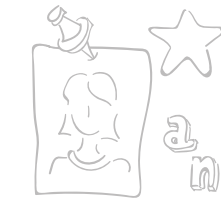

personalisation



nature



comfort



routine



confidence

and purple indicates the common areas!

yellow = 1 bedroom apartments  
orange = 2+ bedroom apartments



ground floor



first floor

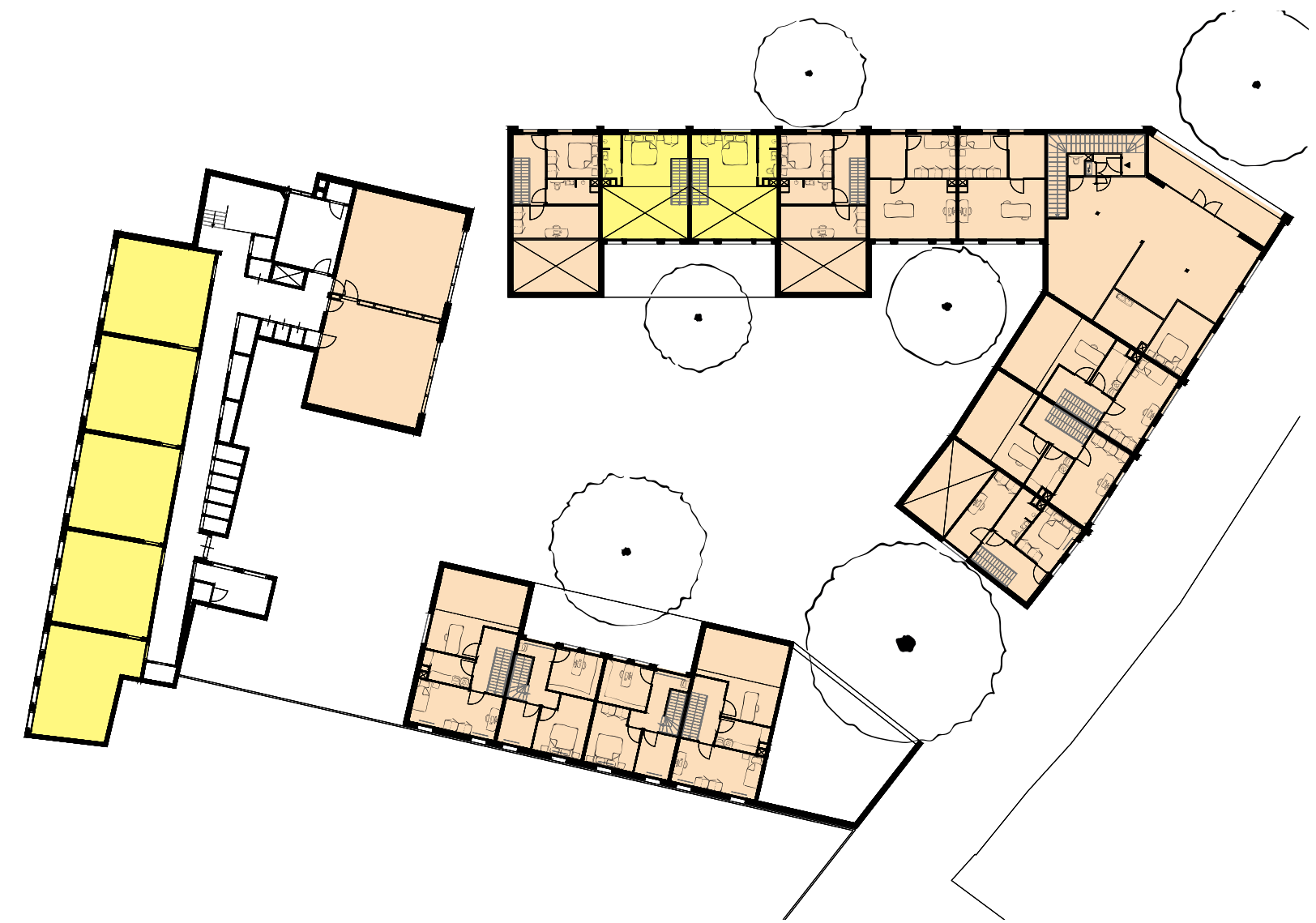

second floor



sound



light



colour

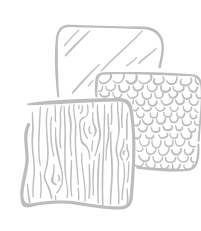

texture



smell



privacy

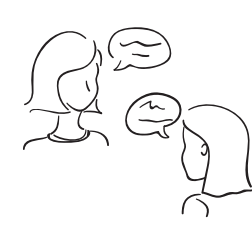

interaction

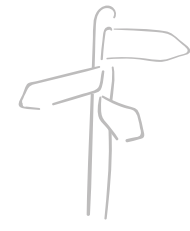

wayfinding

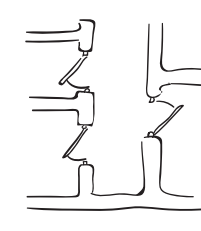

layout

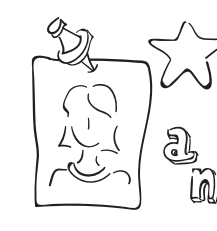

personalisation



nature



comfort



routine



confidence

we can really personalise our floorplans!

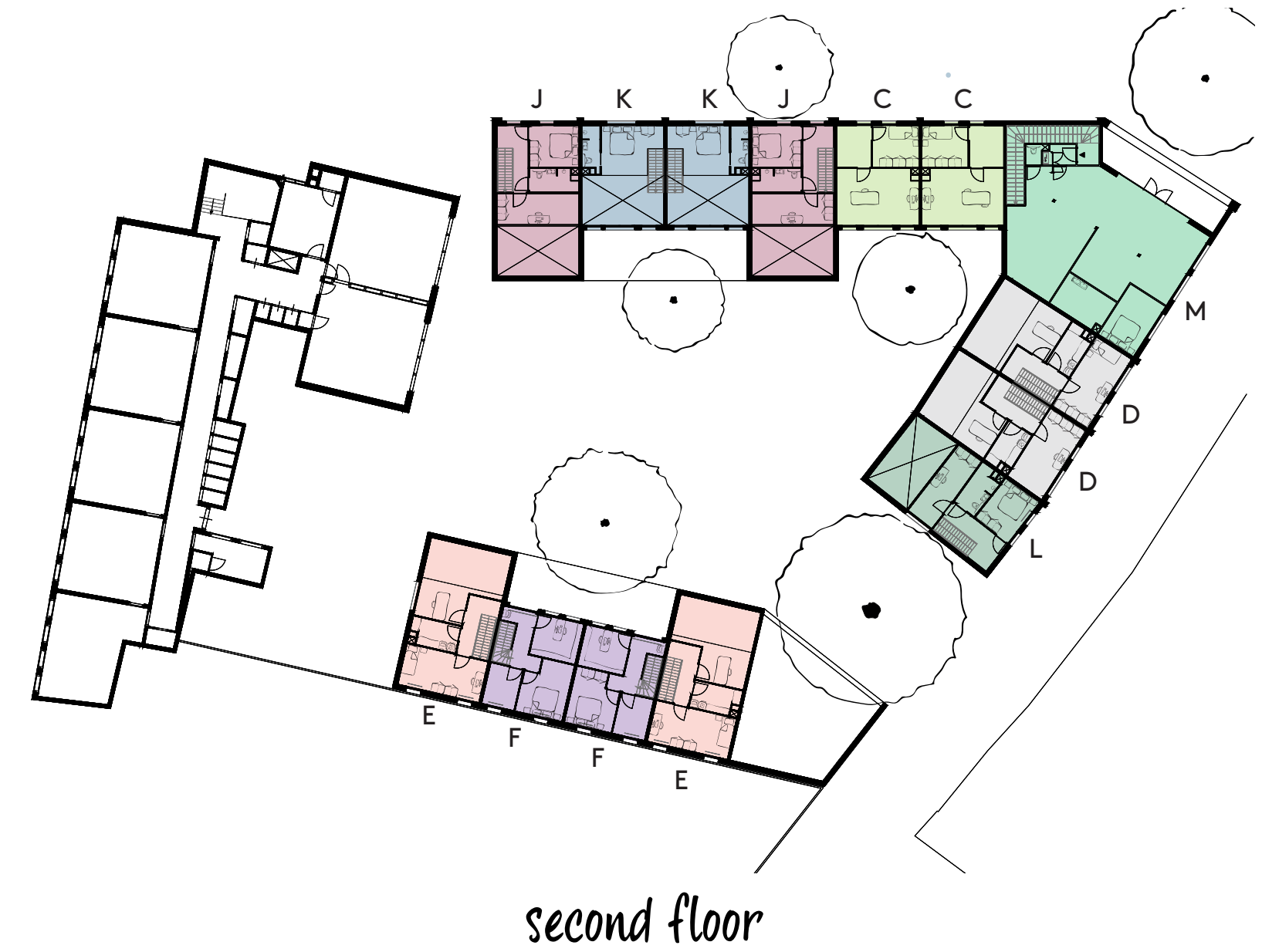

sound



light



colour

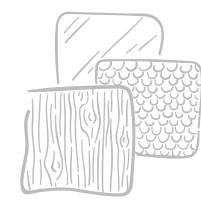

texture



smell



privacy



interaction

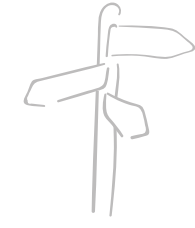

wayfinding

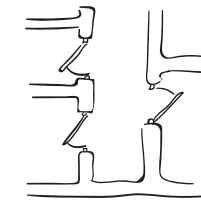

layout

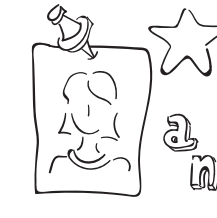

personalisation



nature



comfort

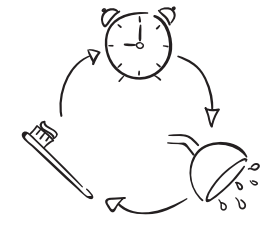

routine



confidence

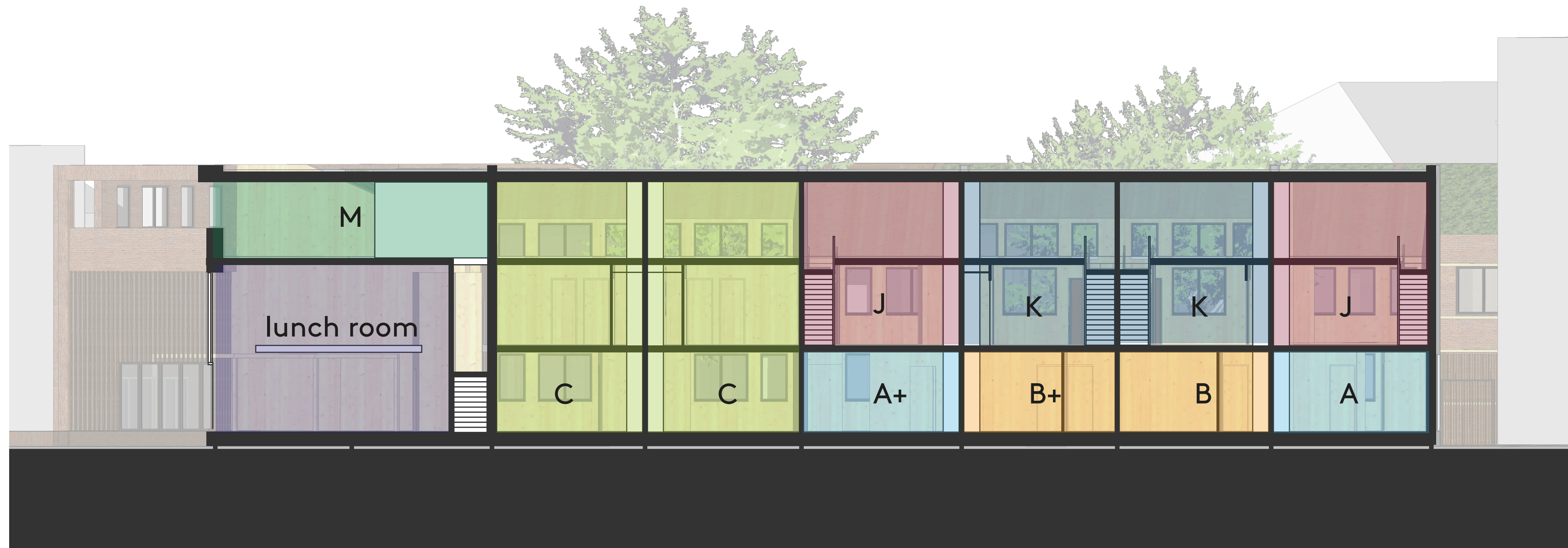

sound



light



colour

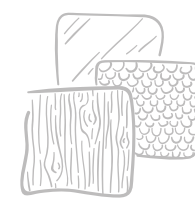

texture



smell



privacy



interaction

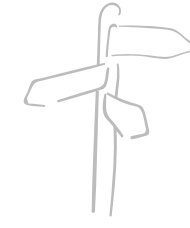

wayfinding



layout



personalisation



nature



comfort



routine



confidence

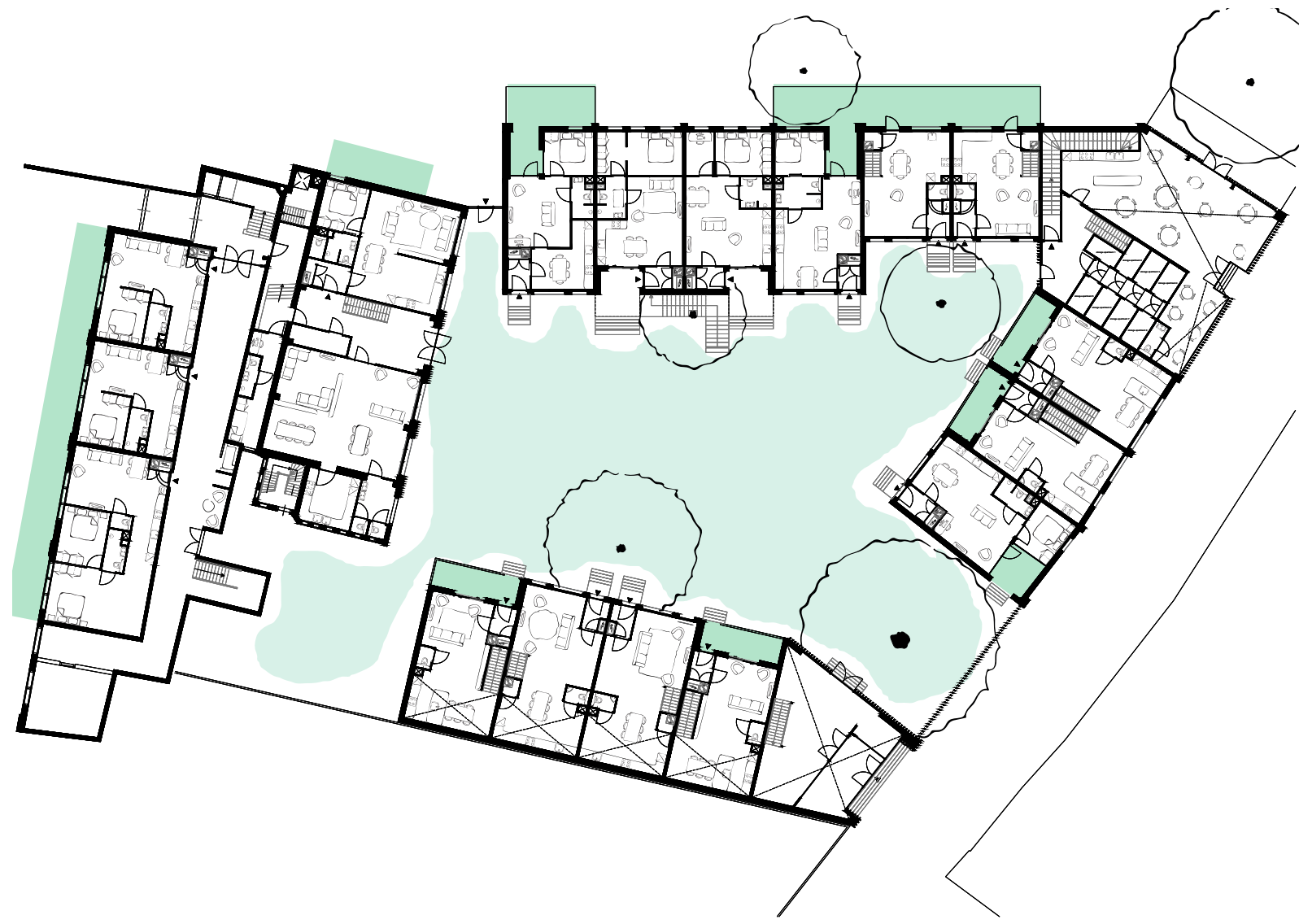

ground floor



first floor

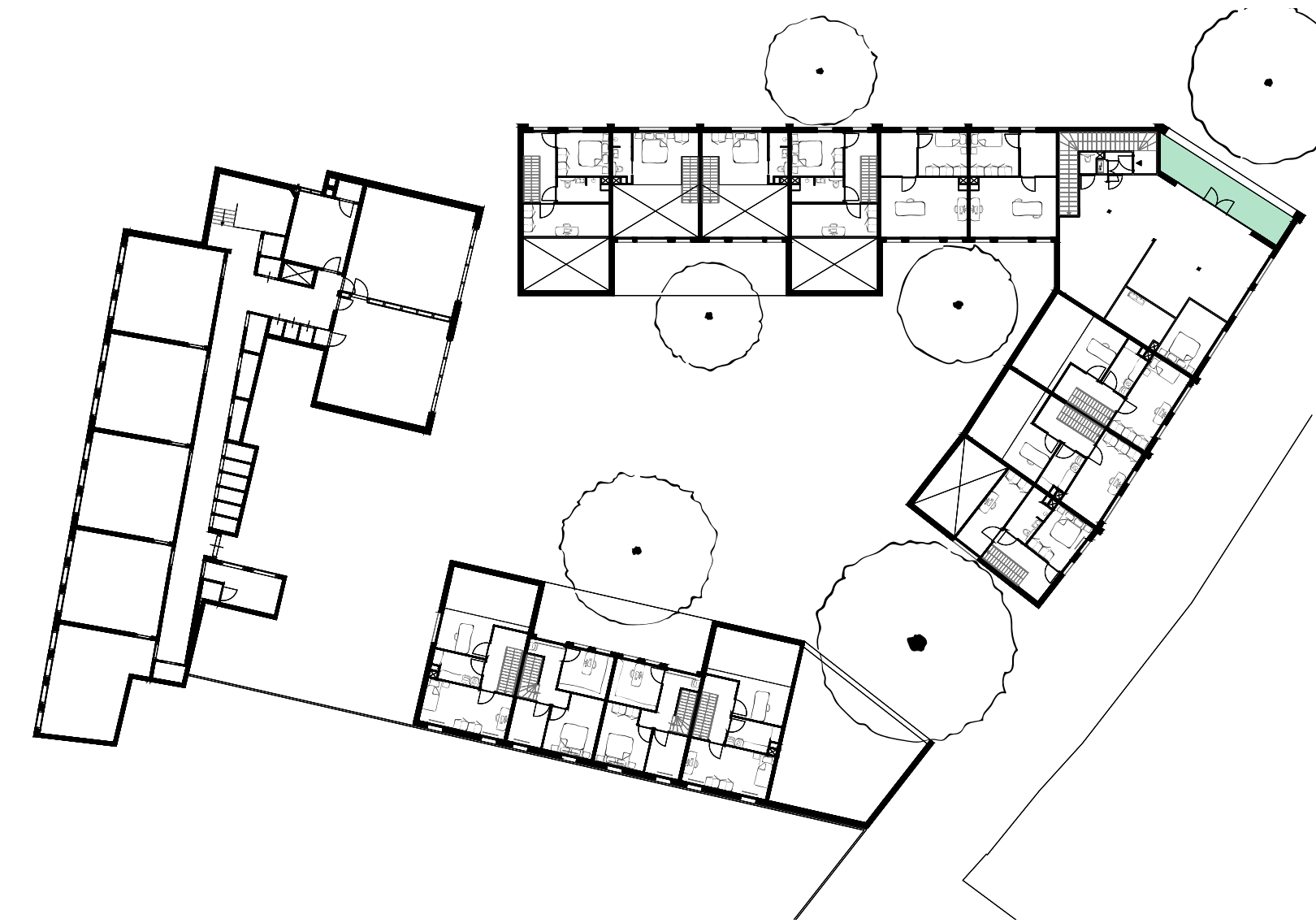

second floor



sound



light



colour

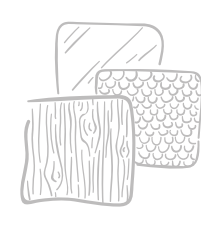

texture



smell



privacy

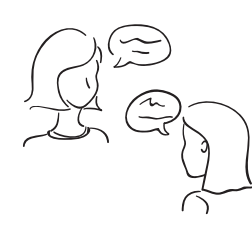

interaction

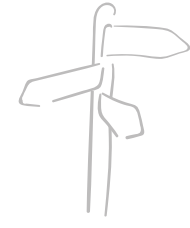

wayfinding

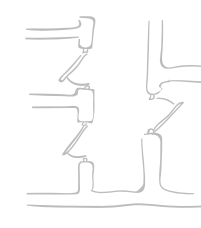

layout

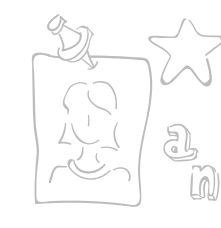

personalisation



nature



comfort



routine

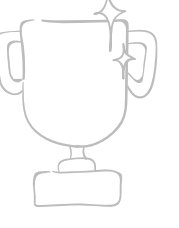

confidence





I'm going to  
tell some more  
about the facade  
and building's  
expression



sound



light



colour

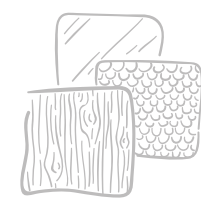

texture



smell



privacy



interaction

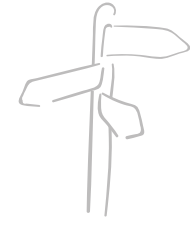

wayfinding

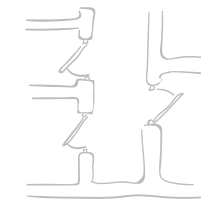

layout

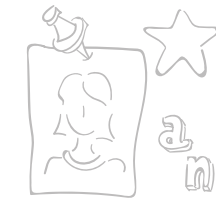

personalisation



nature



comfort



routine



confidence



the building has facades facing the city, as well as facing the courtyard

each of these facades have their own expression

- sound
- light
- colour
- texture
- smell
- privacy
- interaction
- wayfinding
- layout
- personalisation
- nature
- comfort
- routine
- confidence



this is one of the facades facing the city

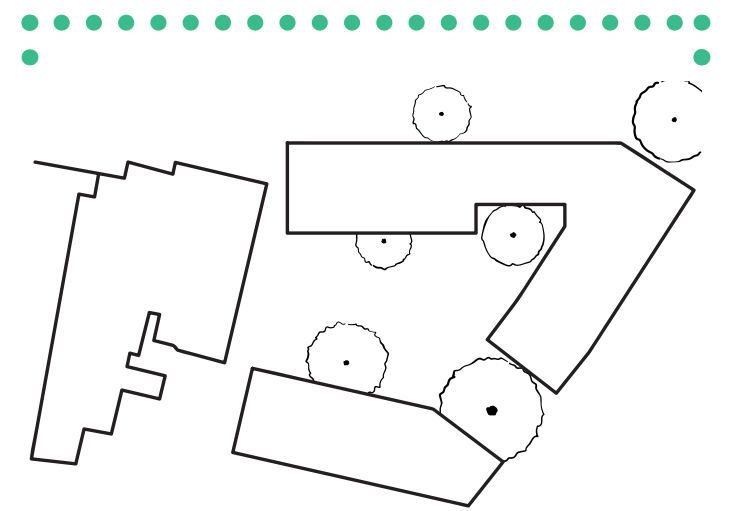

sound



light



colour

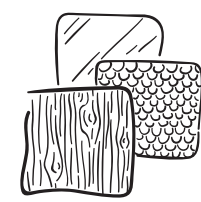

texture



smell



privacy



interaction

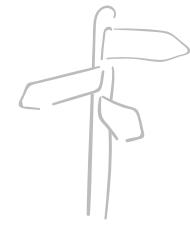

wayfinding

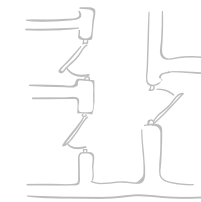

layout



personalisation



nature



comfort



routine



confidence



sound



light



colour

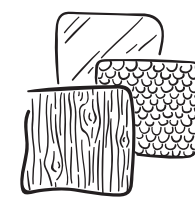

texture



smell



privacy



interaction

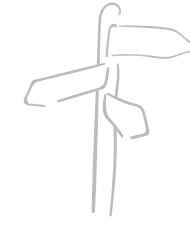

wayfinding

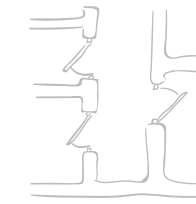

layout



personalisation



nature



comfort



routine



confidence



### Duurzame sloop oude laboratoria in beeld



Duurzaam universiteitsgebouwen slopen



sound



light



colour

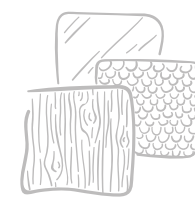

texture



smell



privacy



interaction

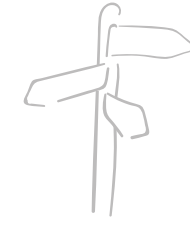

wayfinding



layout



personalisation



nature



comfort



routine



confidence



Duurzame sloop oude laboratoria in beeld



Duurzaam universiteitsgebouwen slopen

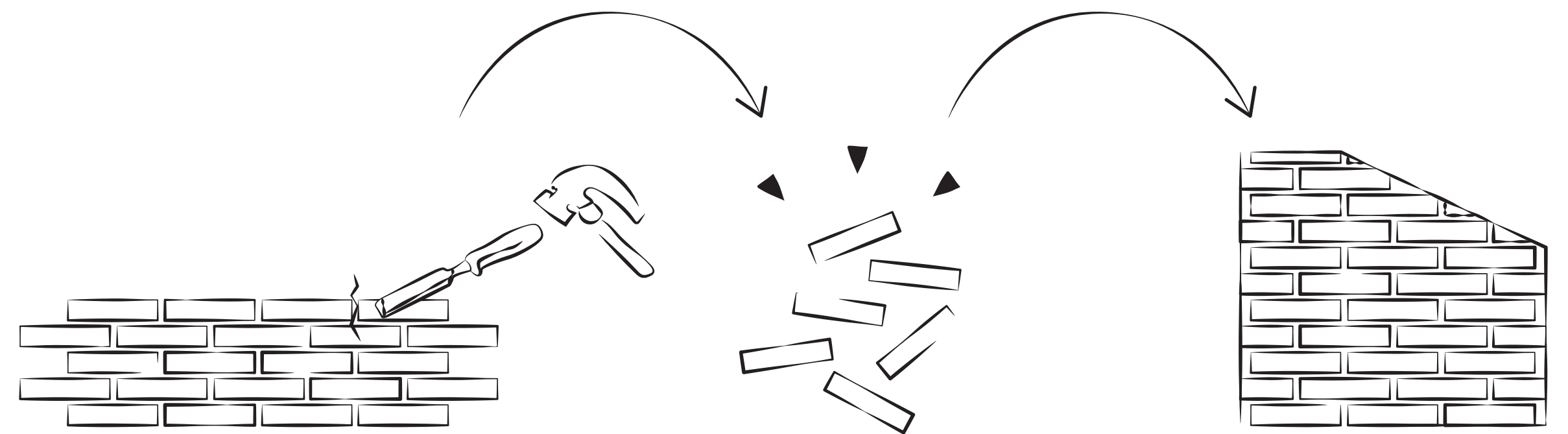

sound



light



colour

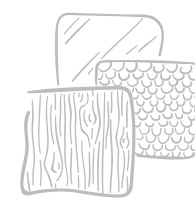

texture



smell



privacy



interaction

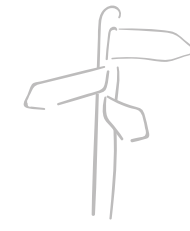

wayfinding



layout



personalisation



nature



comfort



routine



confidence

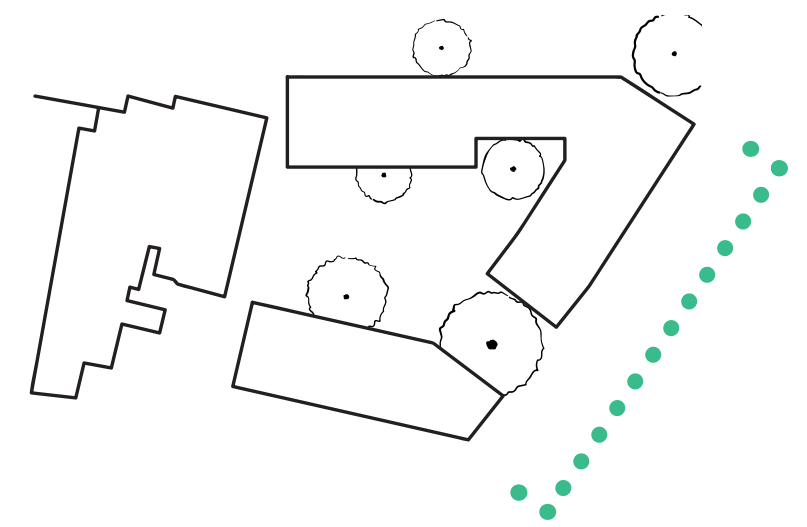

sound



light

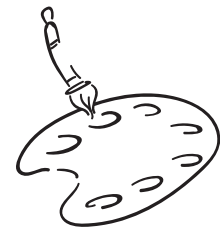

colour

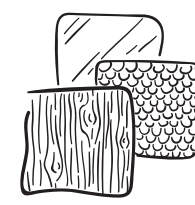

texture



smell



privacy



interaction

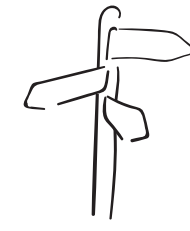

wayfinding

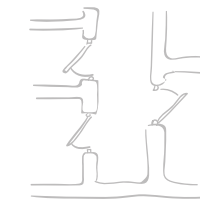

layout



personalisation



nature



comfort



routine



confidence



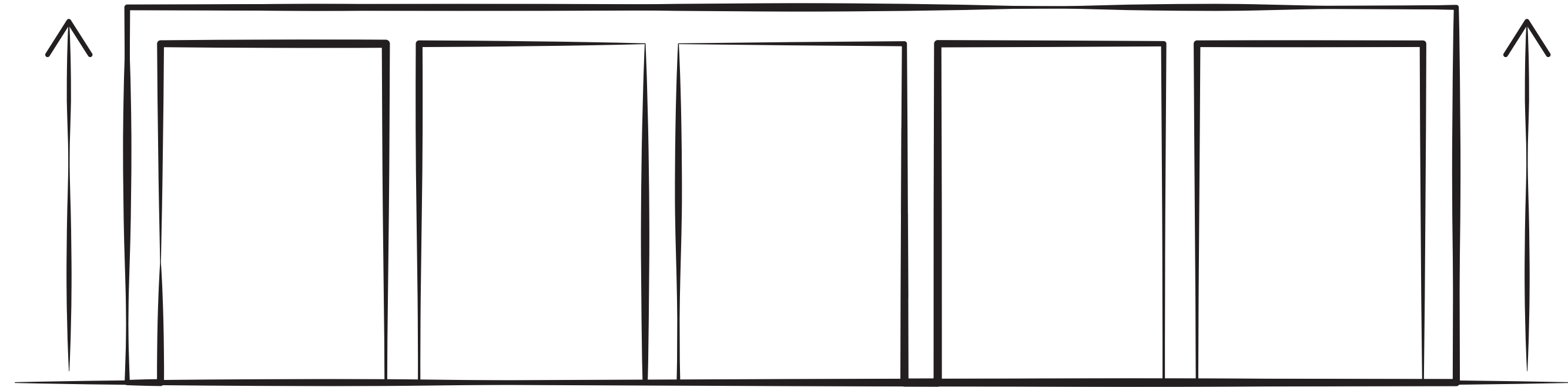

sound



light



colour

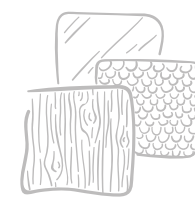

texture



smell



privacy



interaction

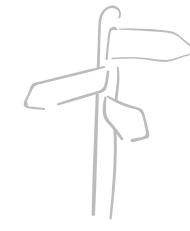

wayfinding



layout



personalisation



nature



comfort



routine



confidence

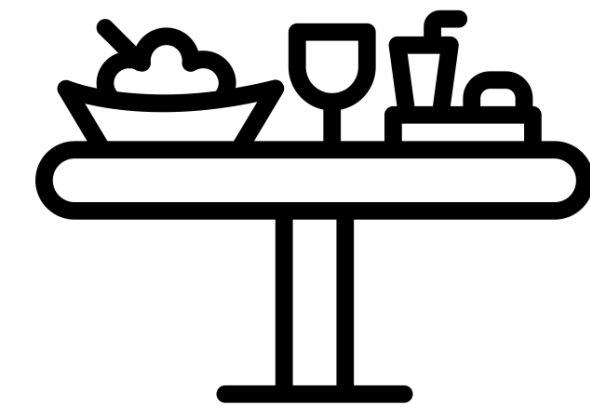
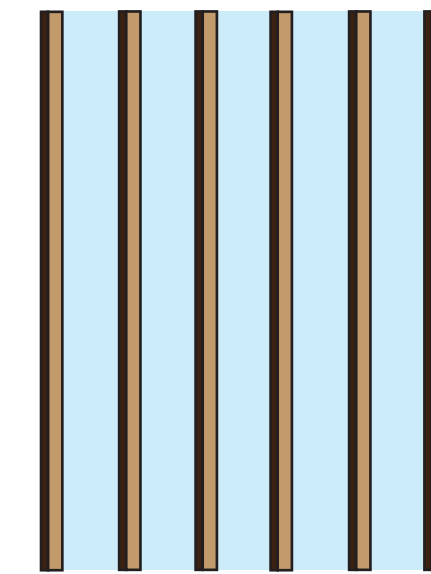
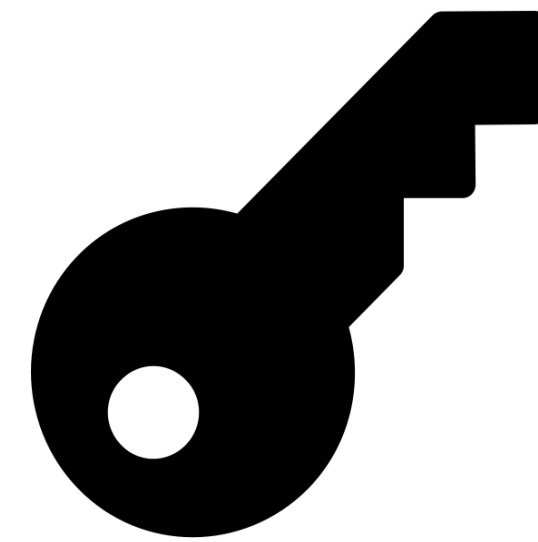
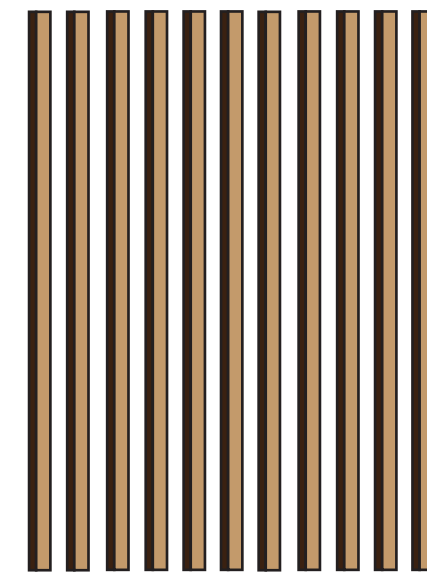
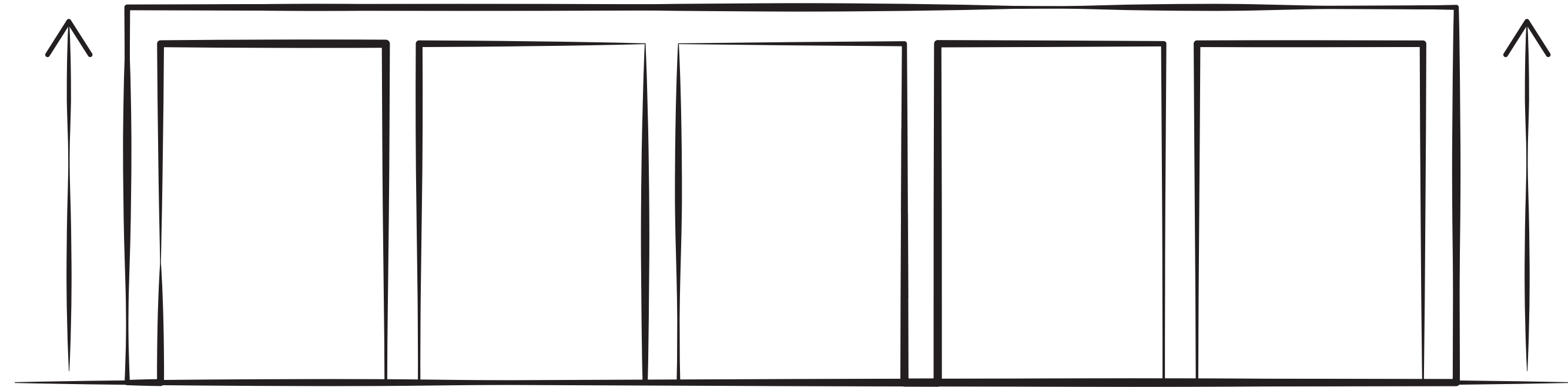

sound



light



colour

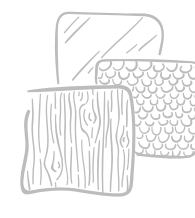

texture



smell



privacy

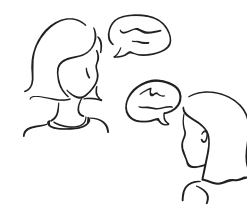

interaction

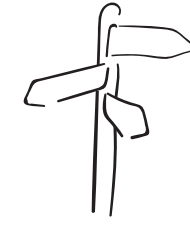

wayfinding



layout



personalisation



nature



comfort



routine



confidence

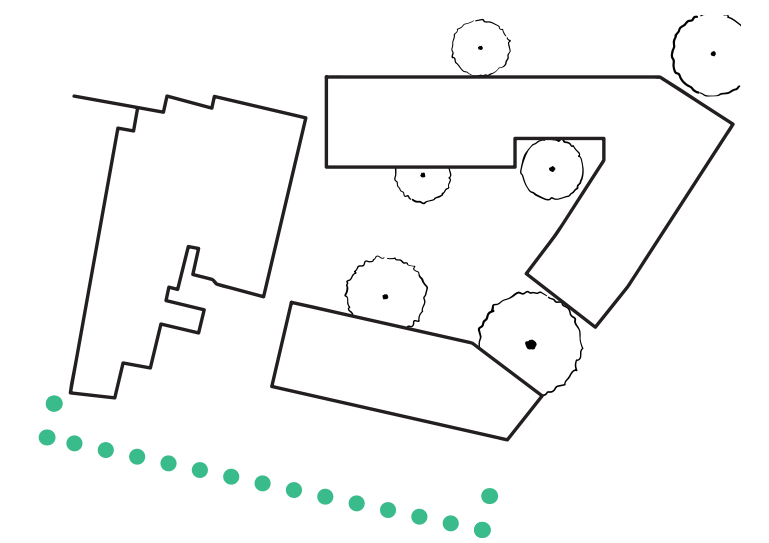

sound



light



colour

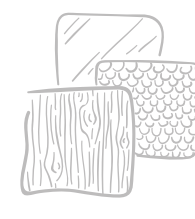

texture



smell



privacy



interaction

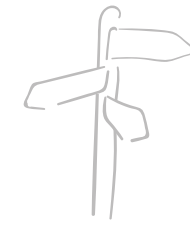

wayfinding



layout



personalisation



nature



comfort



routine



confidence

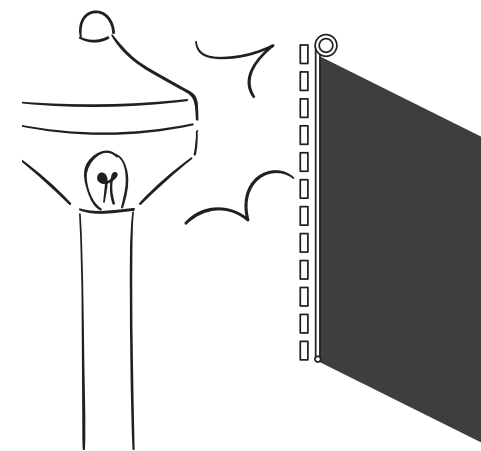
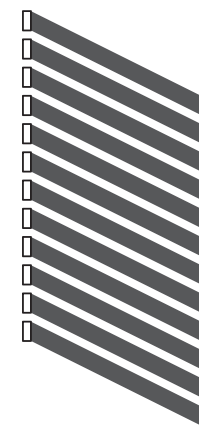
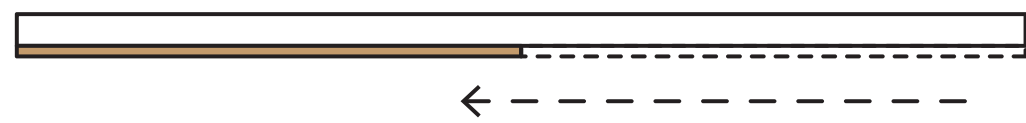
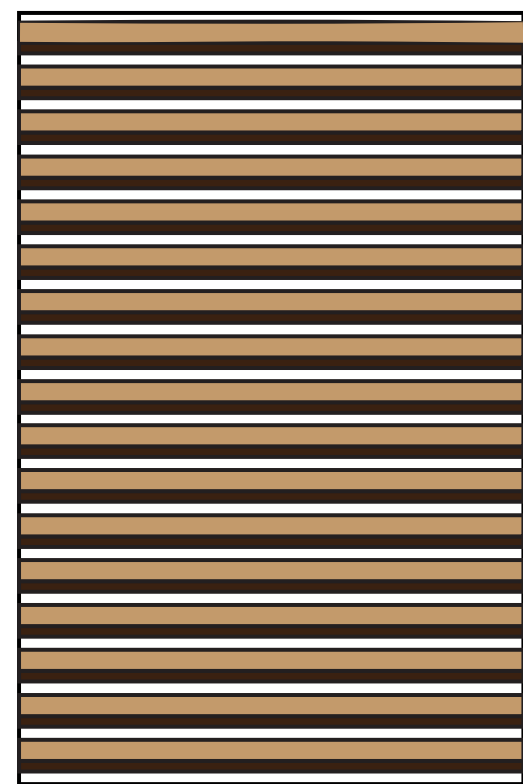
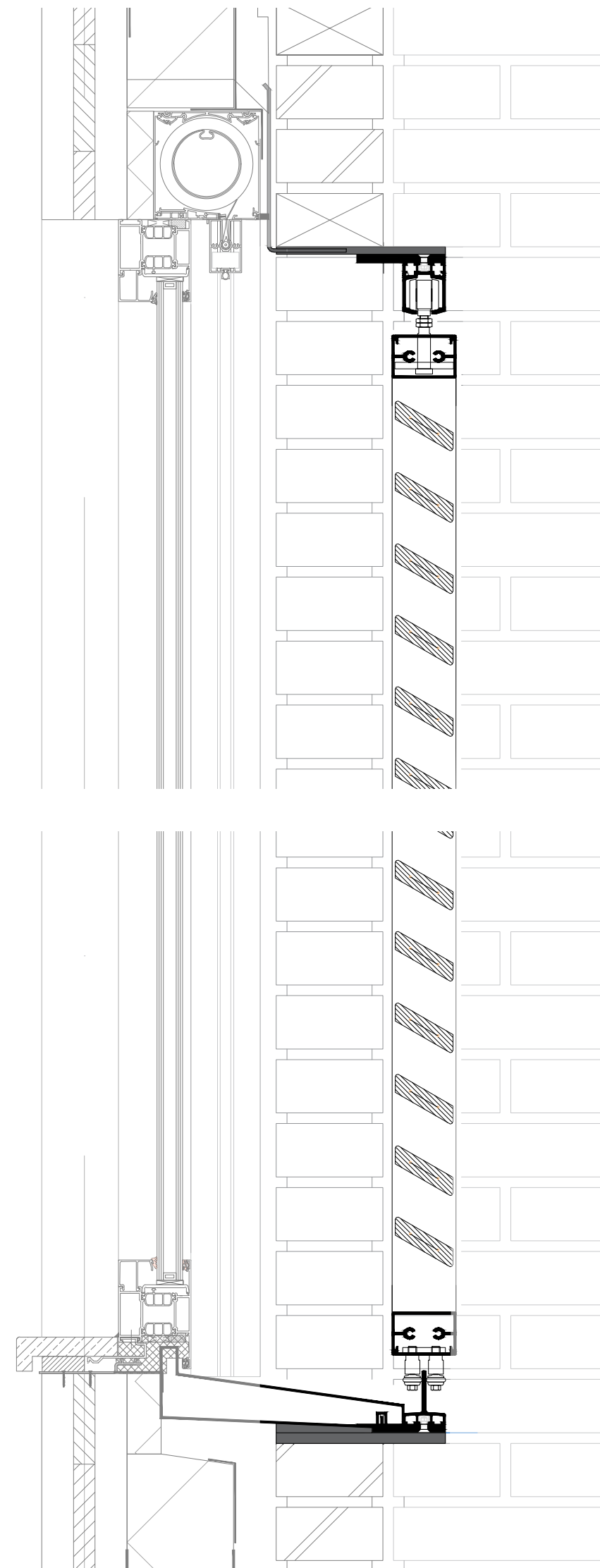

These shutters are adjustable!



sound



light



colour

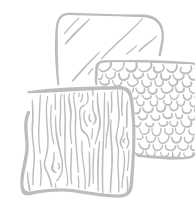

texture



smell



privacy



interaction



wayfinding

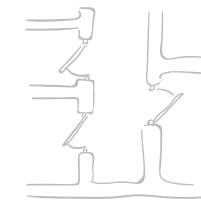

layout

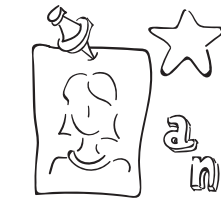

personalisation



nature



comfort



routine



confidence

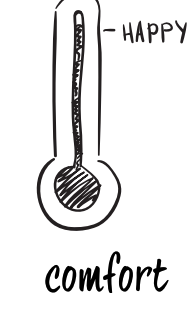
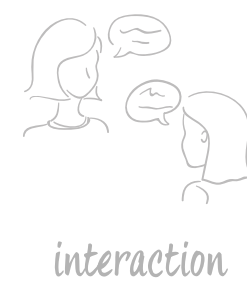
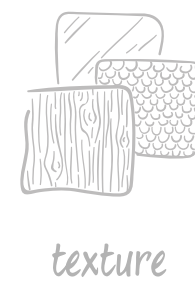
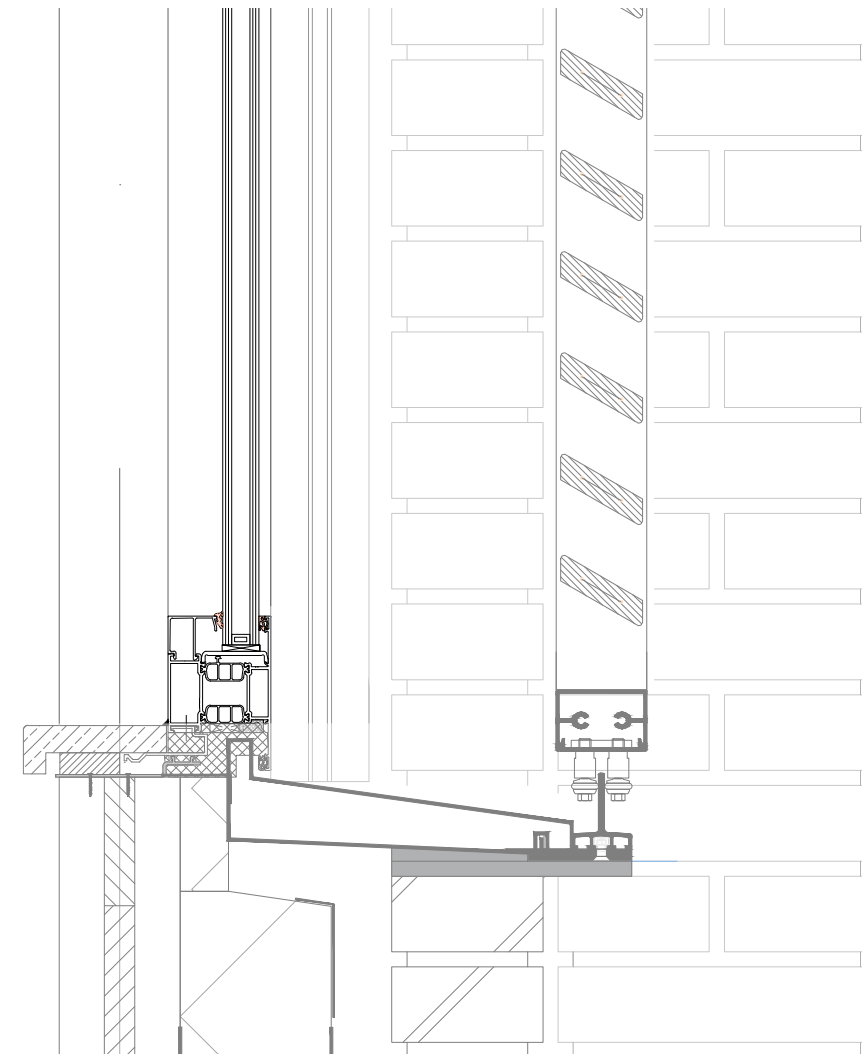
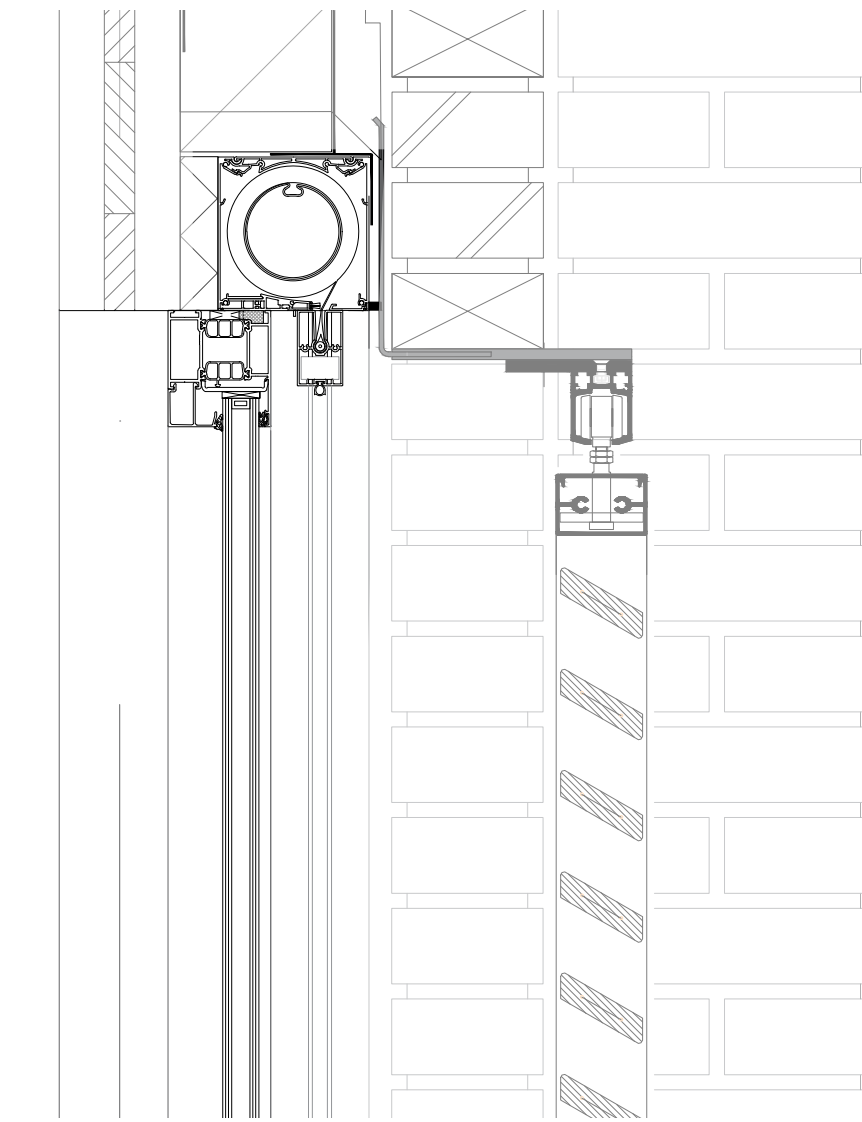
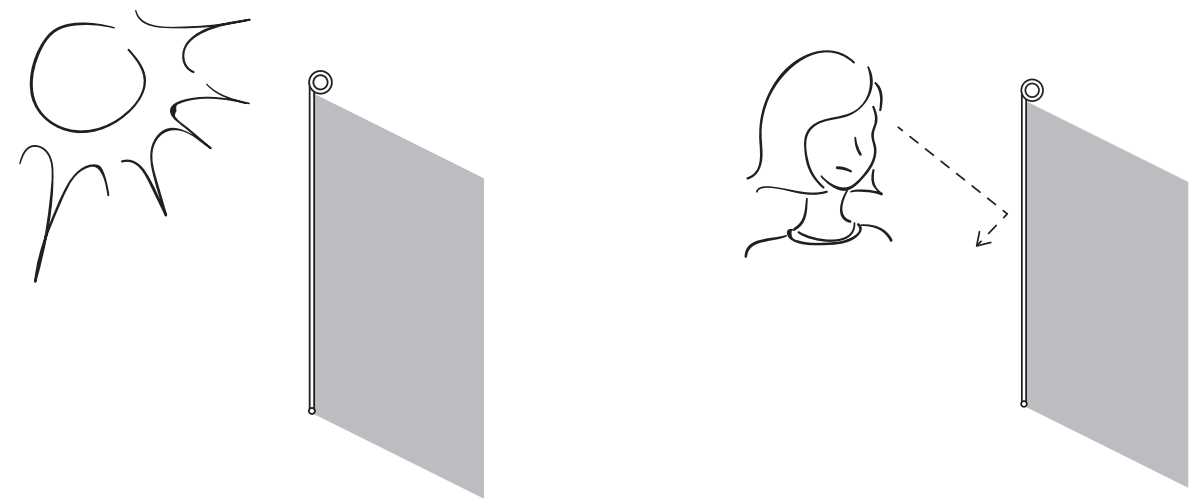
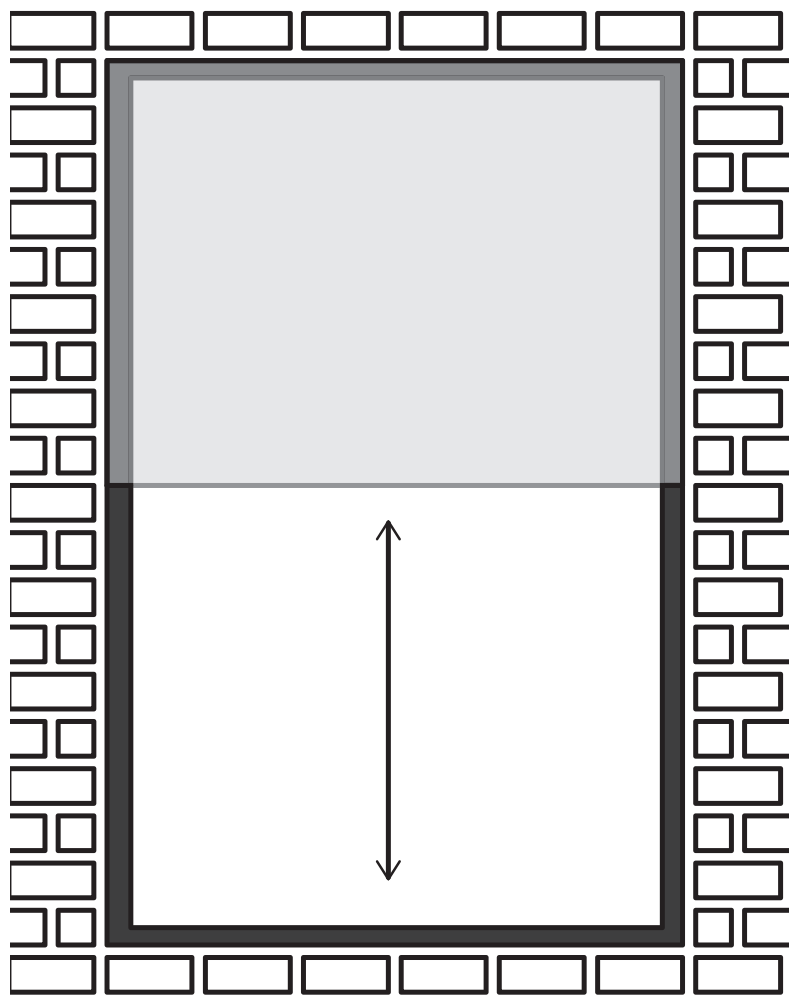

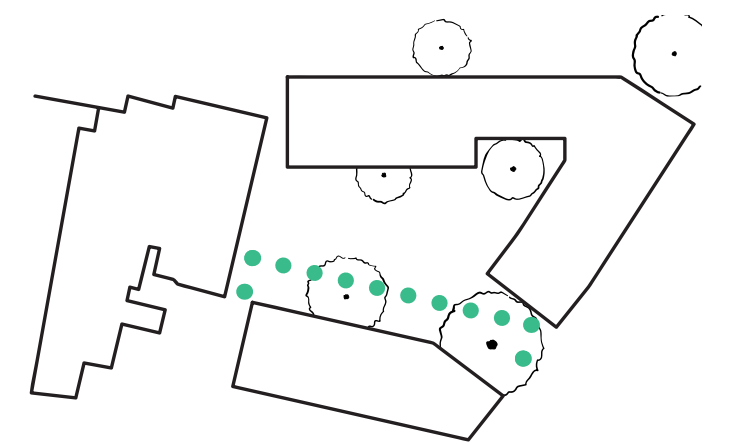

sound



light



colour

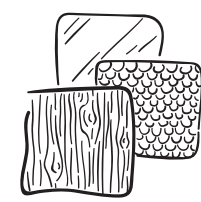

texture



smell



privacy

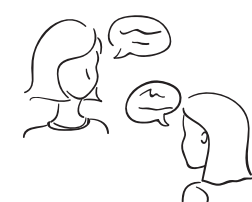

interaction



wayfinding

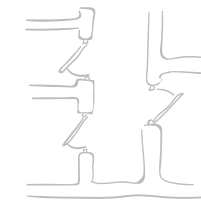

layout

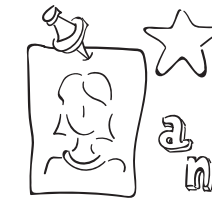

personalisation



nature



comfort



routine



confidence

# north facade courtyard



the building mimics the horizontal bands that show in the school's facade

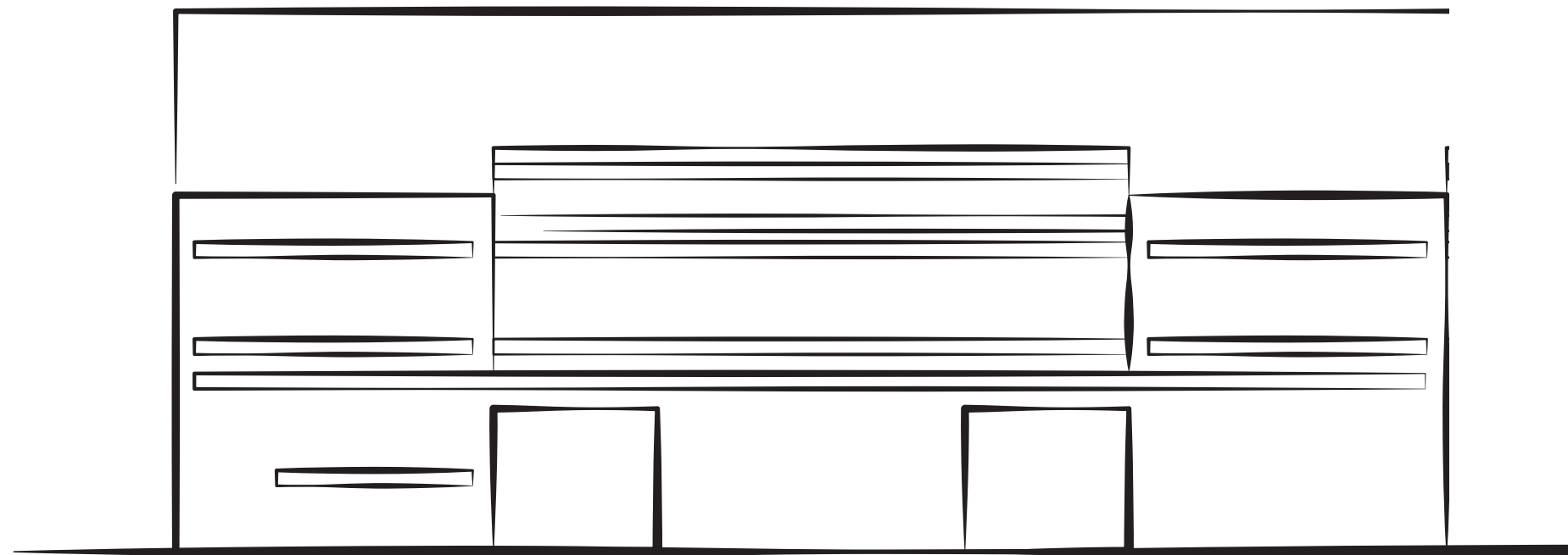

sound



light

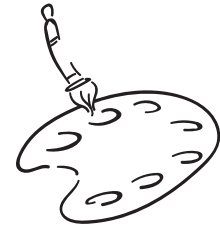

colour

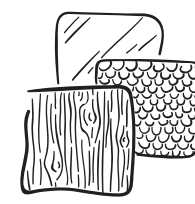

texture



smell



privacy



interaction

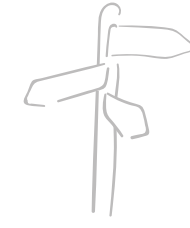

wayfinding

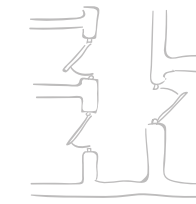

layout



personalisation



nature



comfort

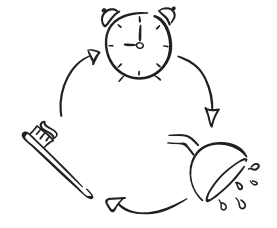

routine



confidence

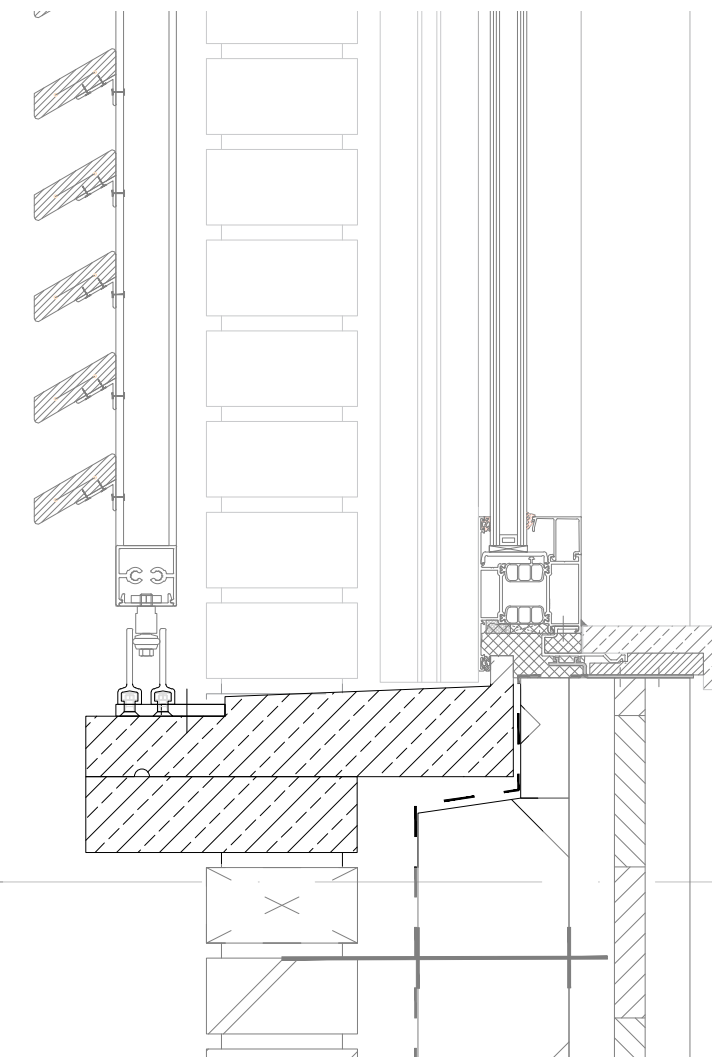
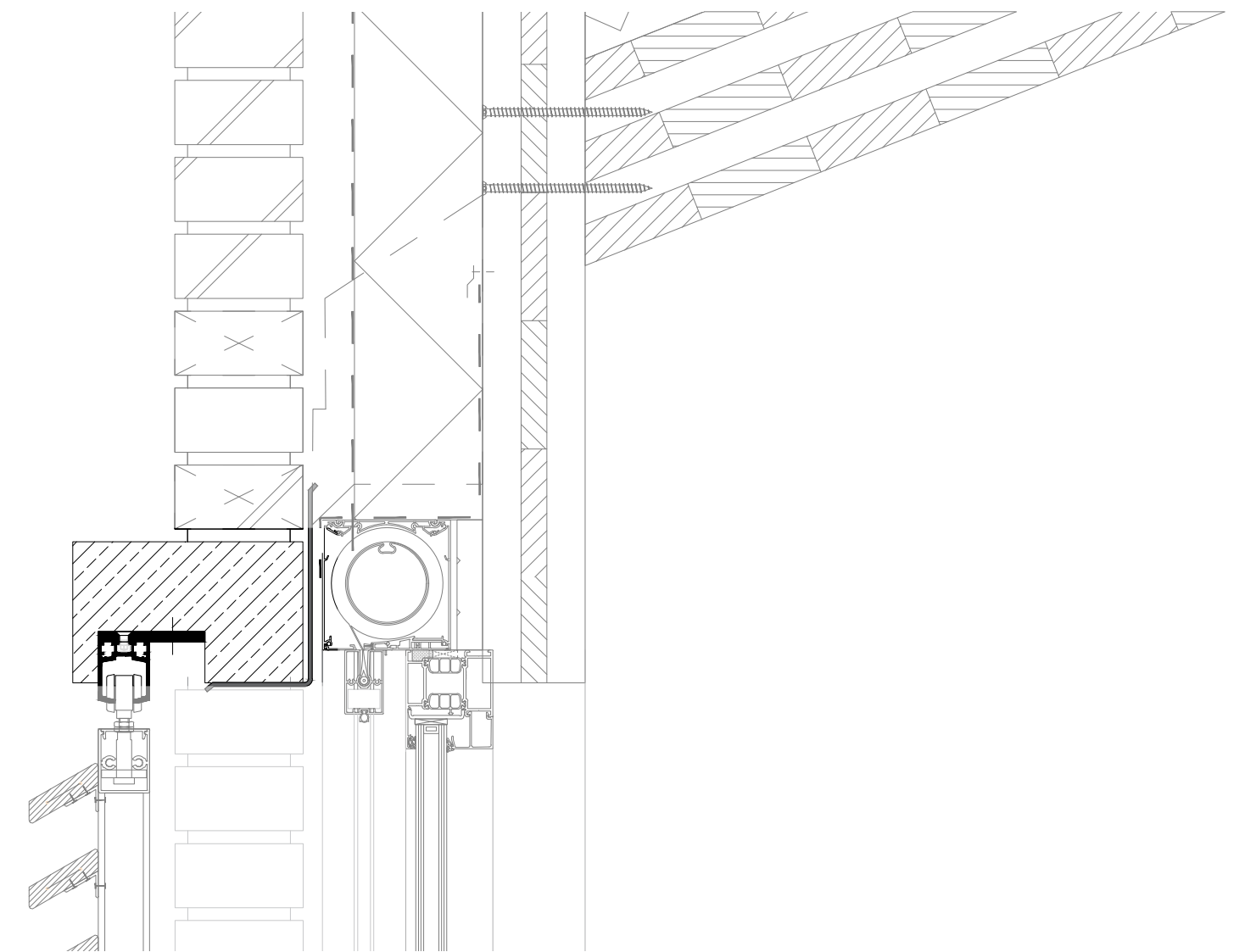
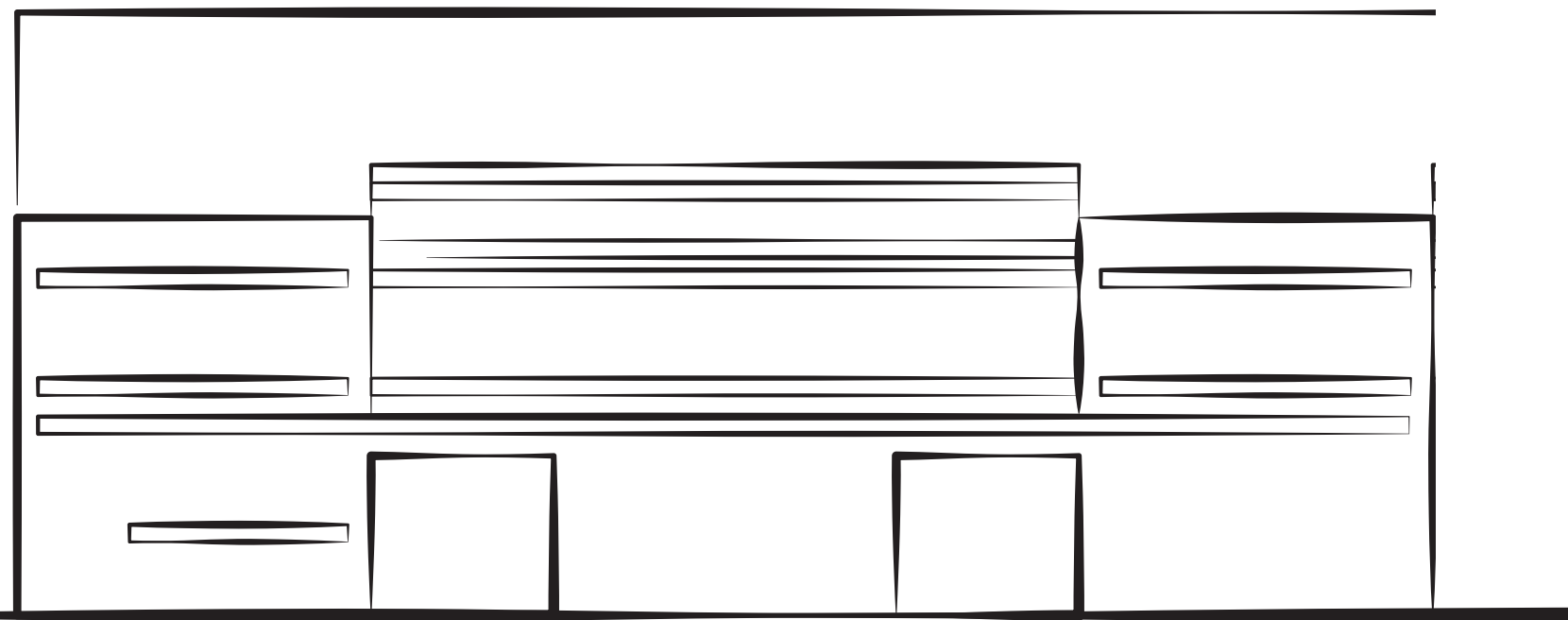

sound



light

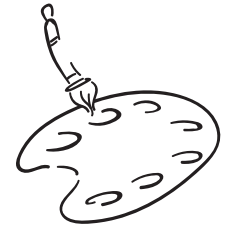

colour

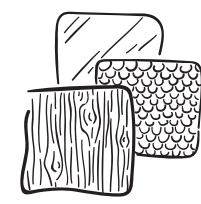

texture



smell



privacy

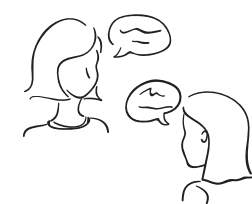

interaction



wayfinding

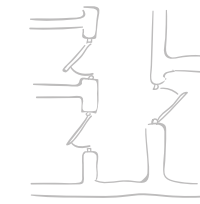

layout



personalisation



nature



comfort

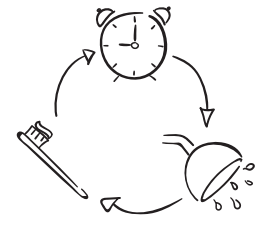

routine



confidence



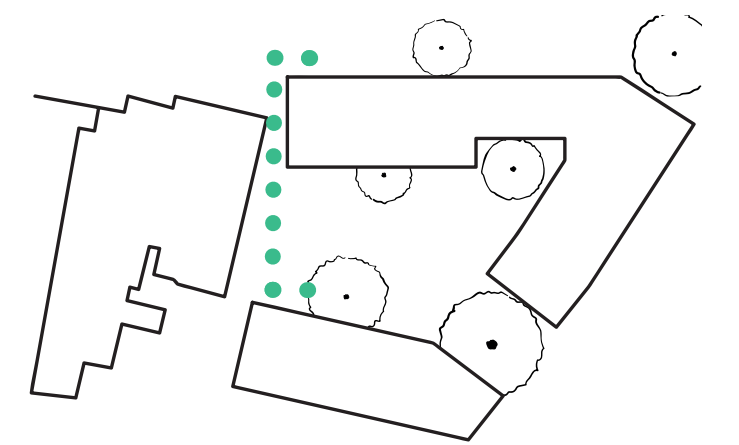

sound



light

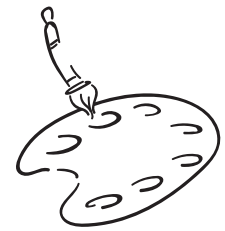

colour

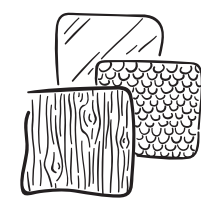

texture



smell



privacy



interaction

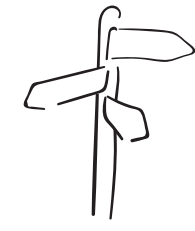

wayfinding

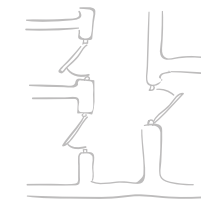

layout

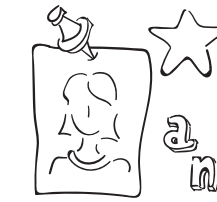

personalisation



nature



comfort



routine



confidence

# south-west facade courtyard



special bricks for some happy little birds, bees, and butterflies

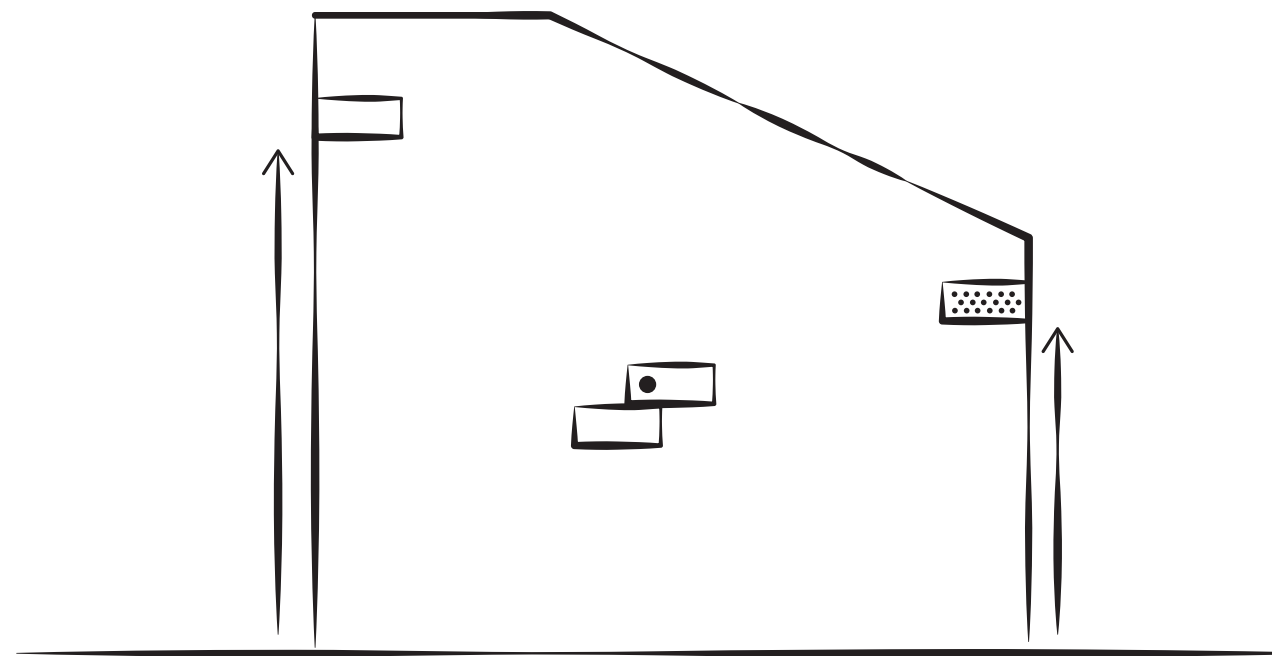
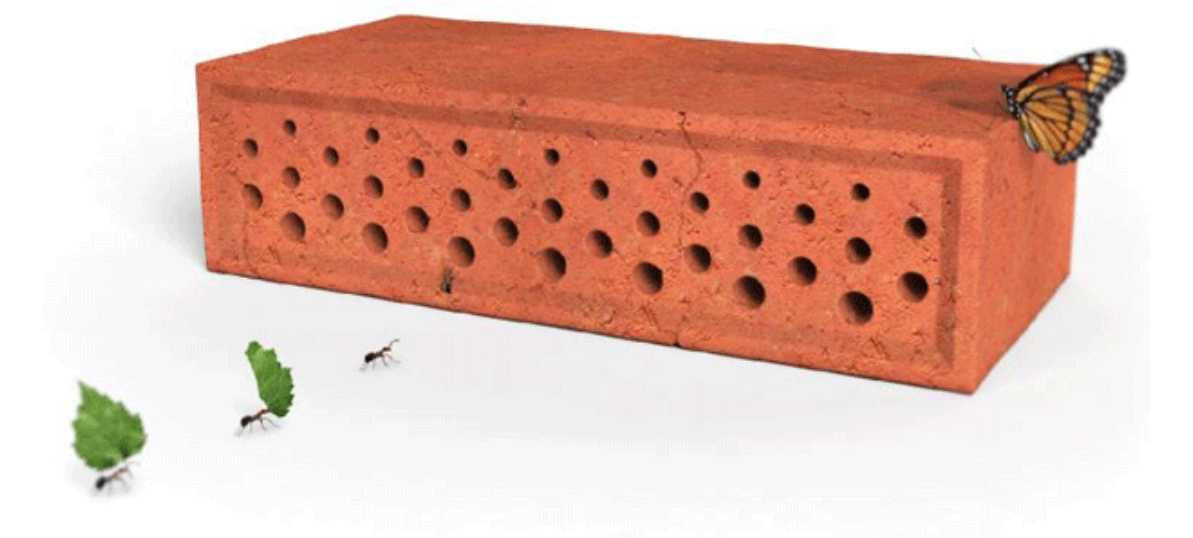

sound



light



colour

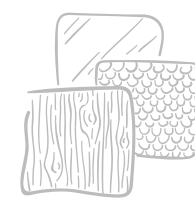

texture



smell



privacy



interaction

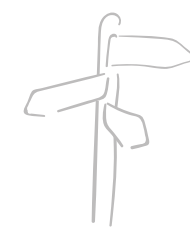

wayfinding



layout



personalisation



nature



comfort



routine



confidence

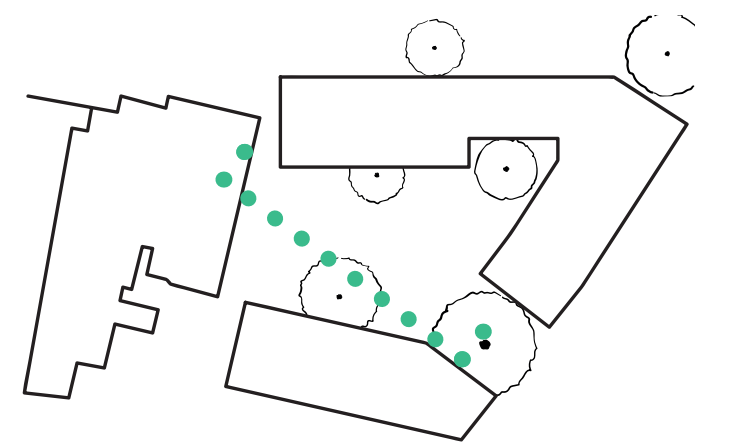

sound



light



colour

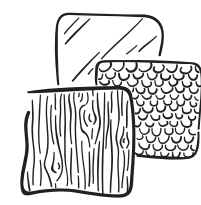

texture



smell



privacy

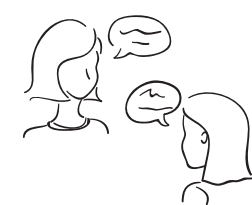

interaction

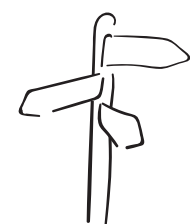

wayfinding

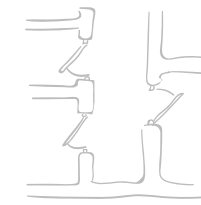

layout

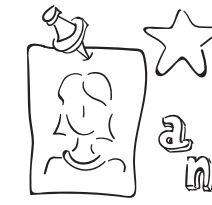

personalisation



nature



comfort



routine



confidence

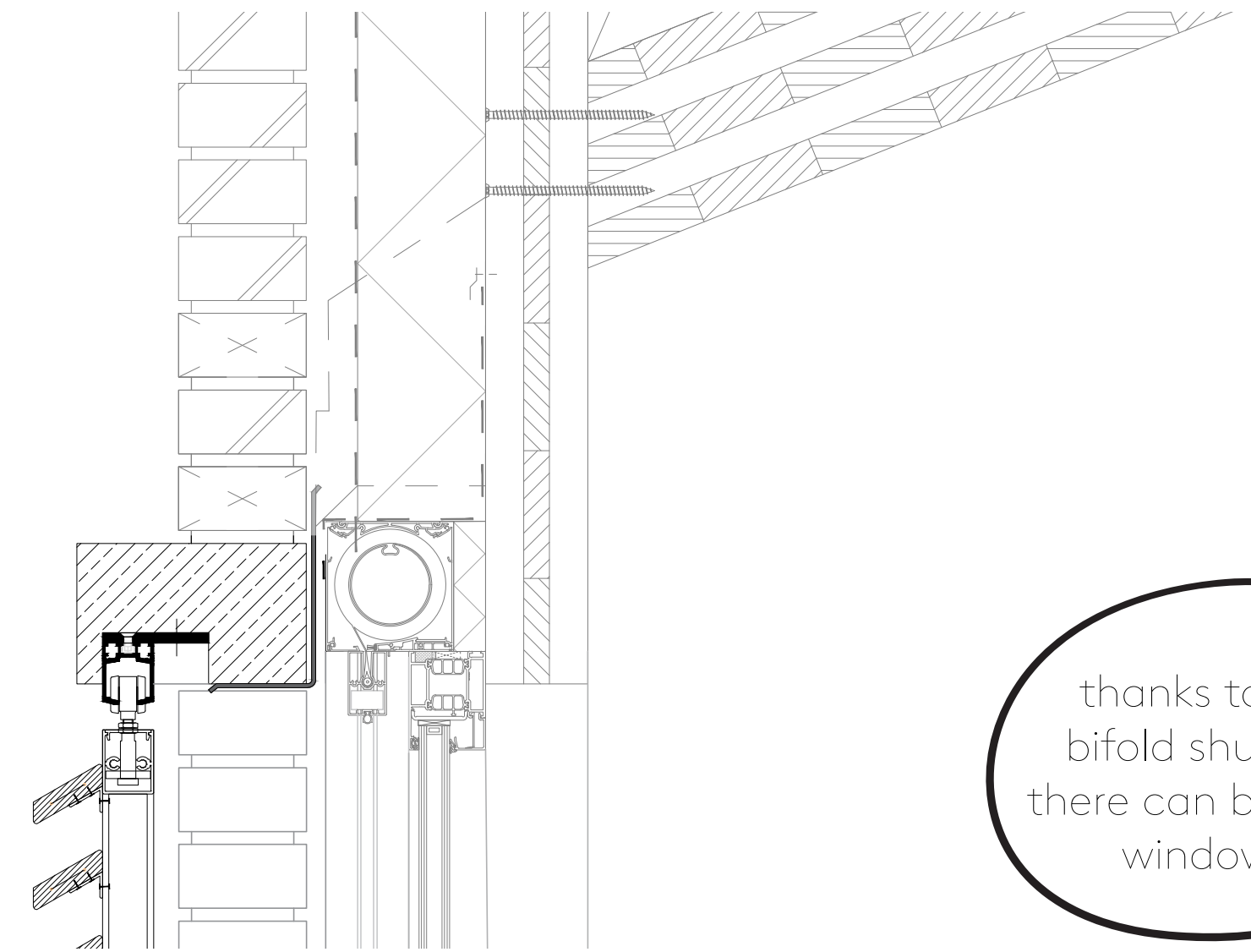

thanks to the bifold shutters, there can be more windows!

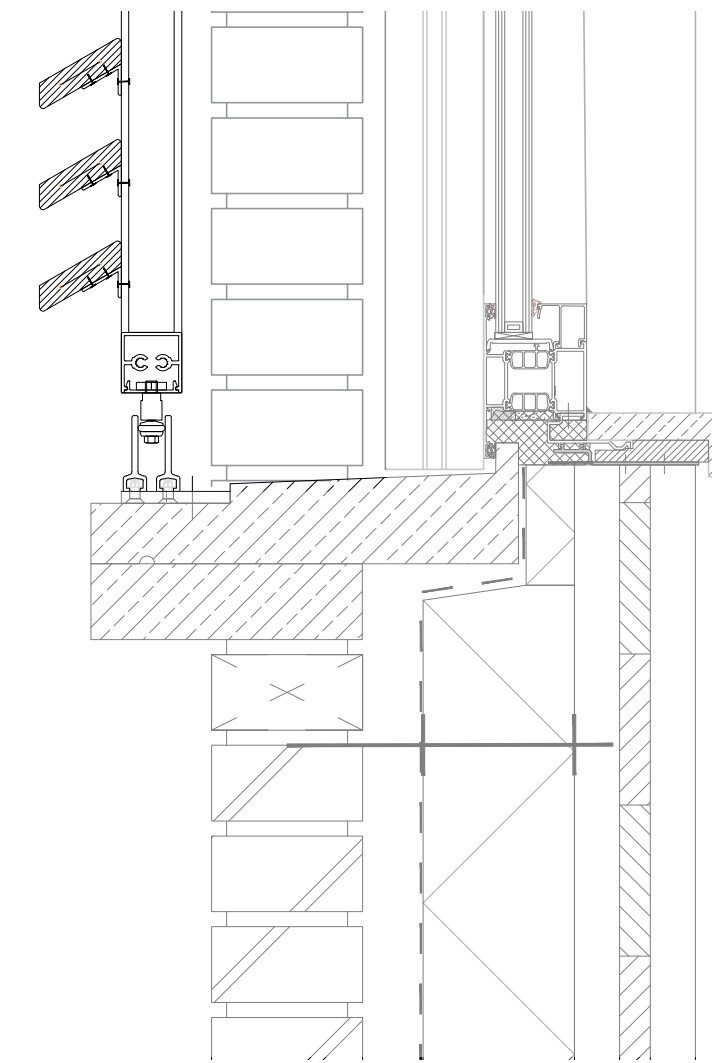
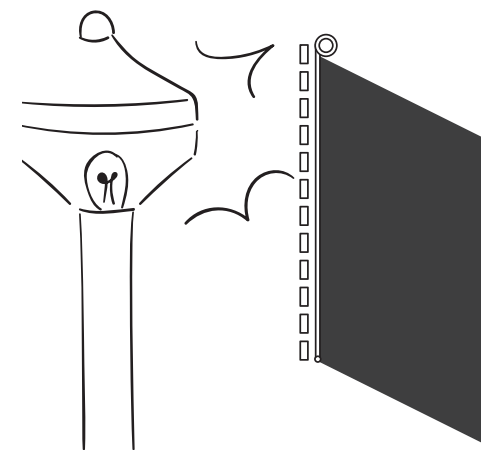
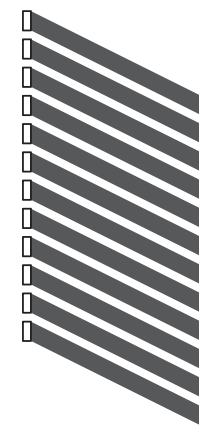
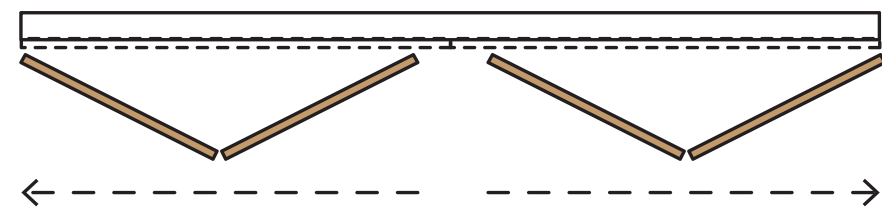
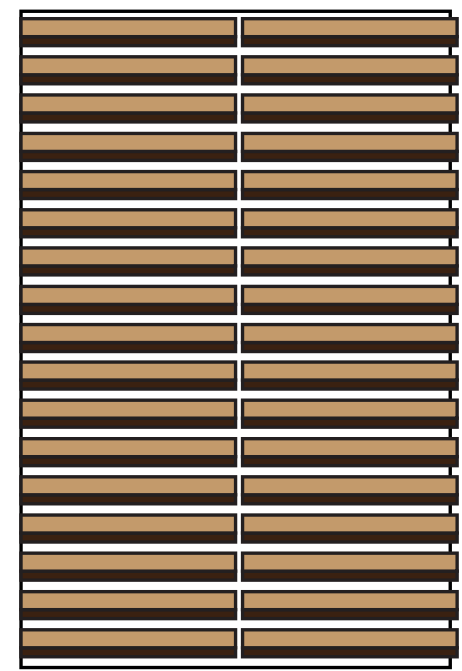

sound



light



colour

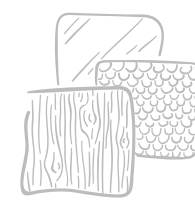

texture



smell



privacy



interaction

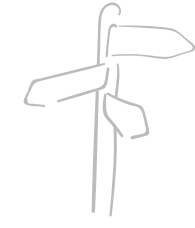

wayfinding



layout

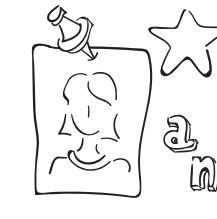

personalisation



nature



comfort



routine



confidence

# north facade courtyard



if the sun is too bright, we can just roll the screen down!

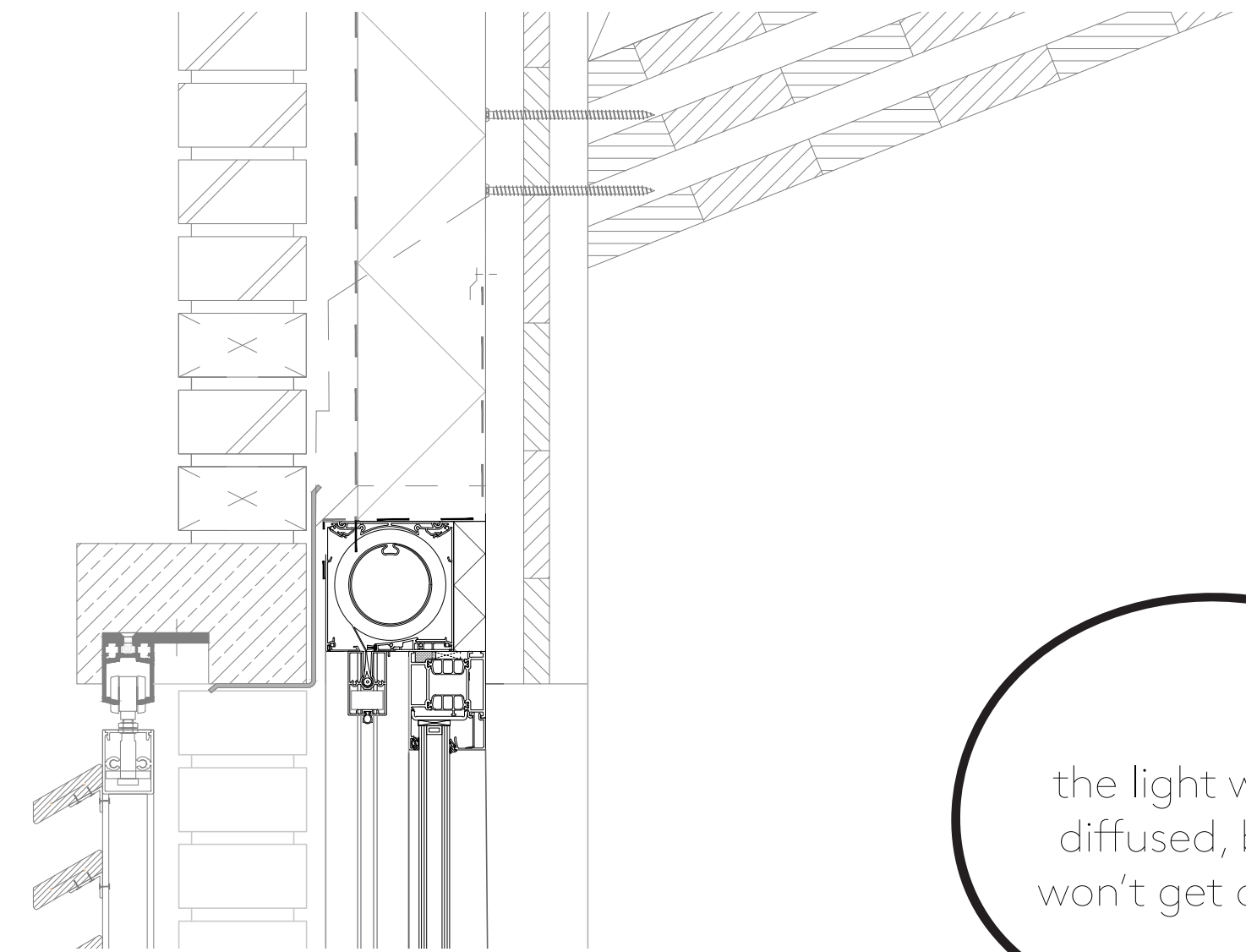

the light will be diffused, but it won't get darker.

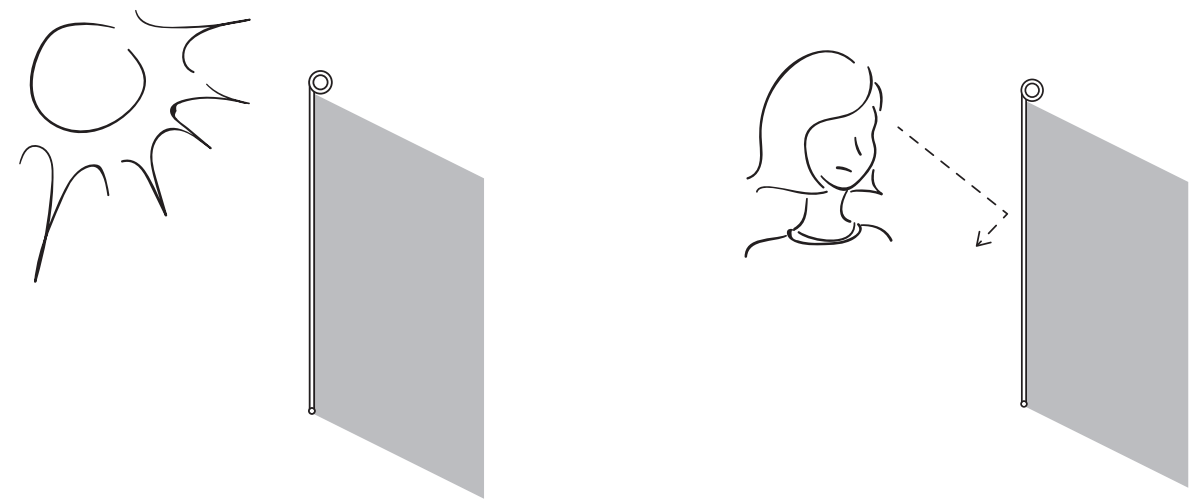
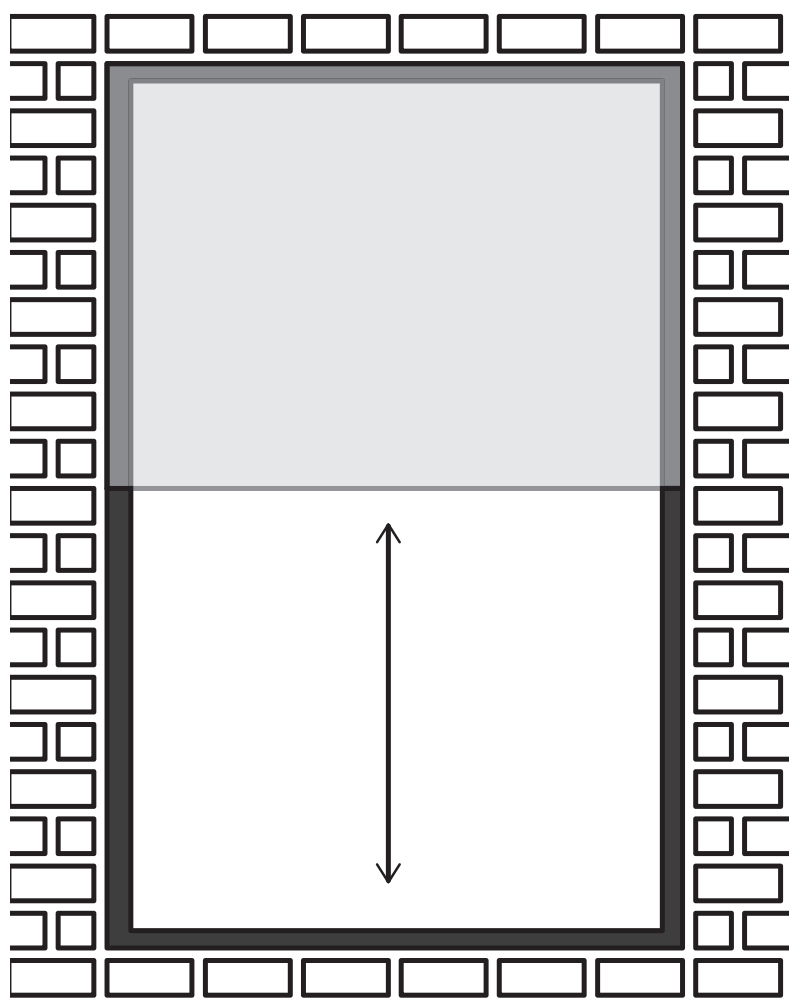
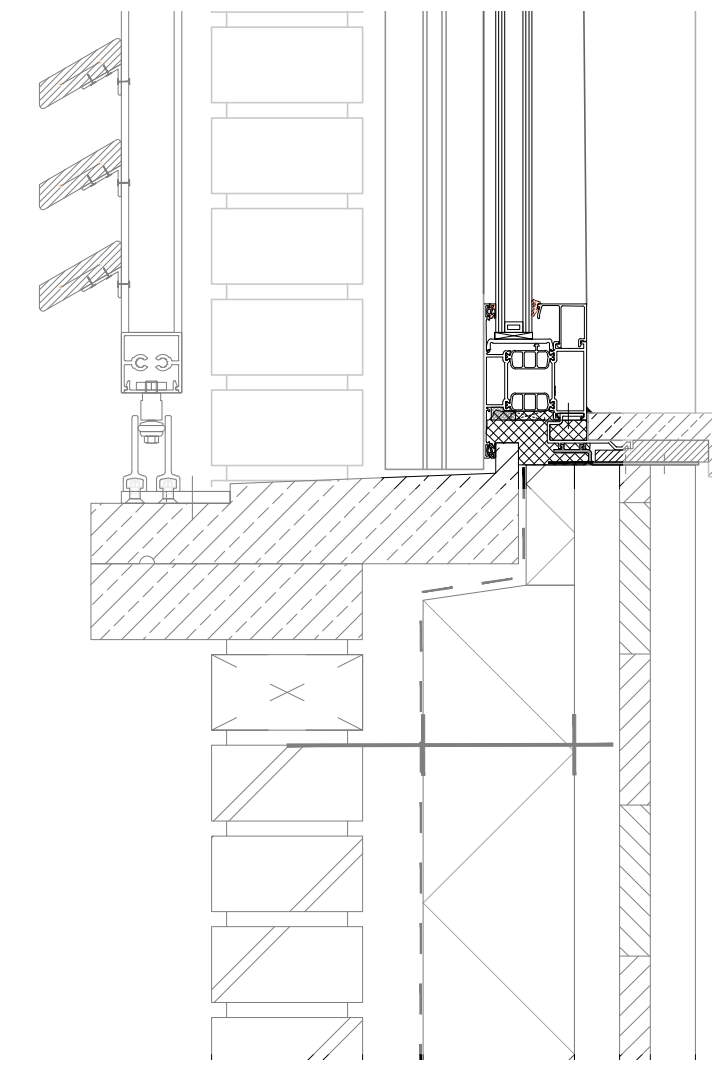

sound



light



colour

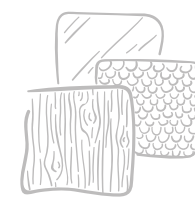

texture



smell



privacy



interaction

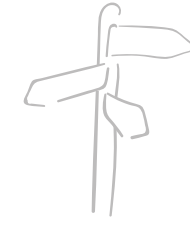

wayfinding



layout



personalisation



nature



comfort



routine



confidence

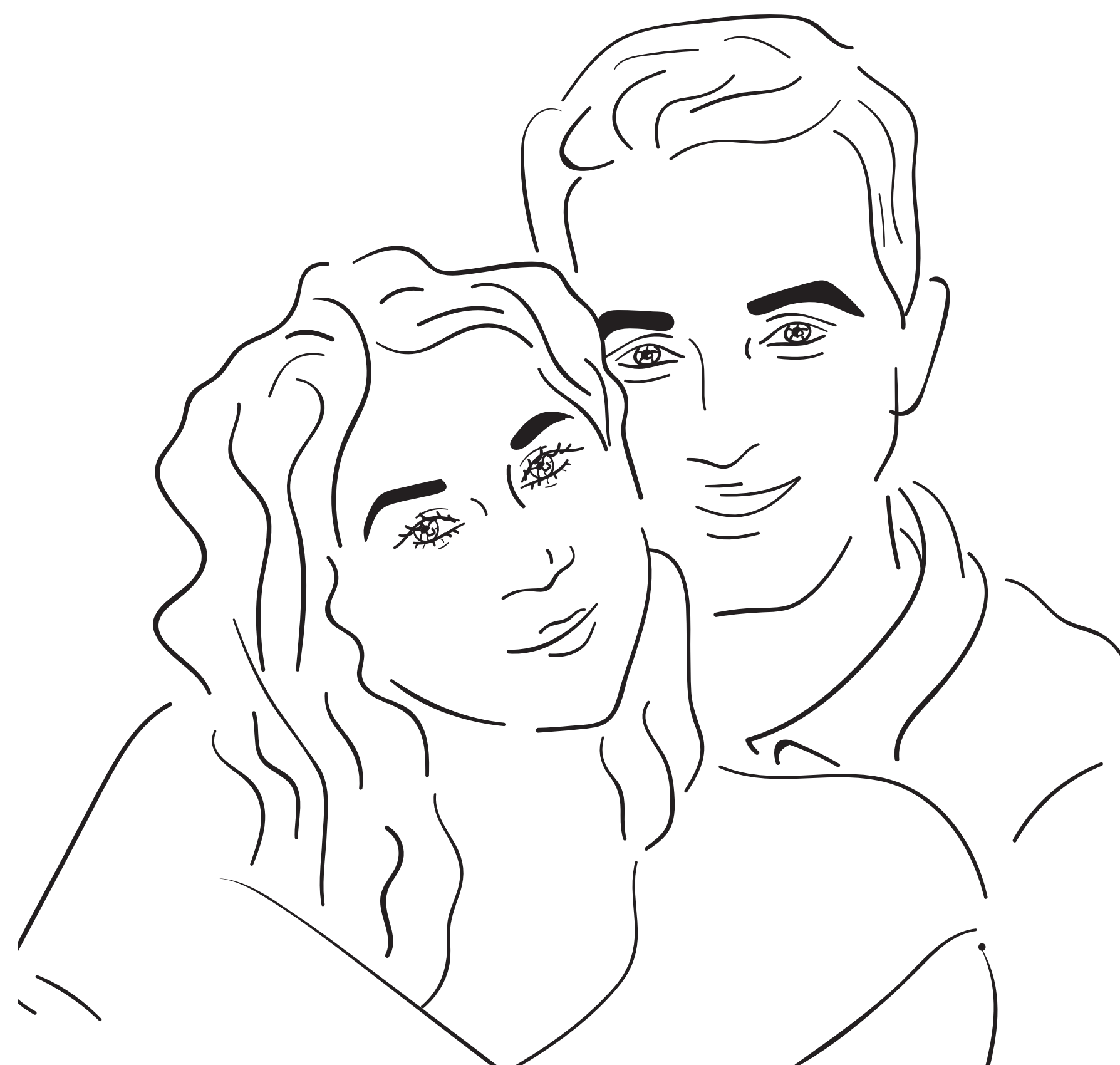

We would like to tell you about the exterior design!

Laura has added a small park at the riverfront ...



... and a sensory garden in the courtyard!



sound



light

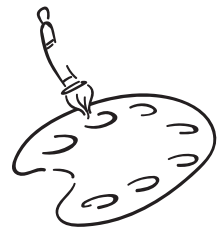

colour

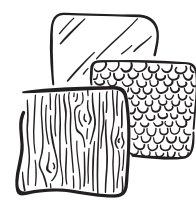

texture



smell



privacy



interaction

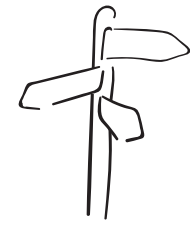

wayfinding

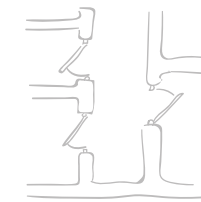

layout



personalisation



nature



comfort



routine



confidence



Let's tell you more about these sections.



sound



light

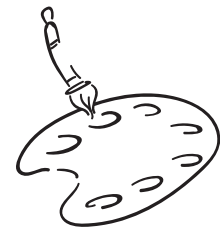

colour

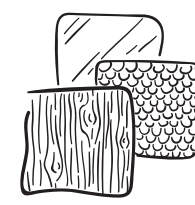

texture



smell



privacy



interaction

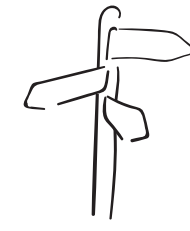

wayfinding

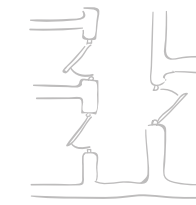

layout



personalisation



nature



comfort



routine

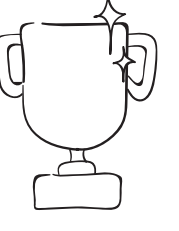

confidence



There are several places to sit and chat ...

... and passersby can enjoy it as well, since the courtyard is open during the daytime!

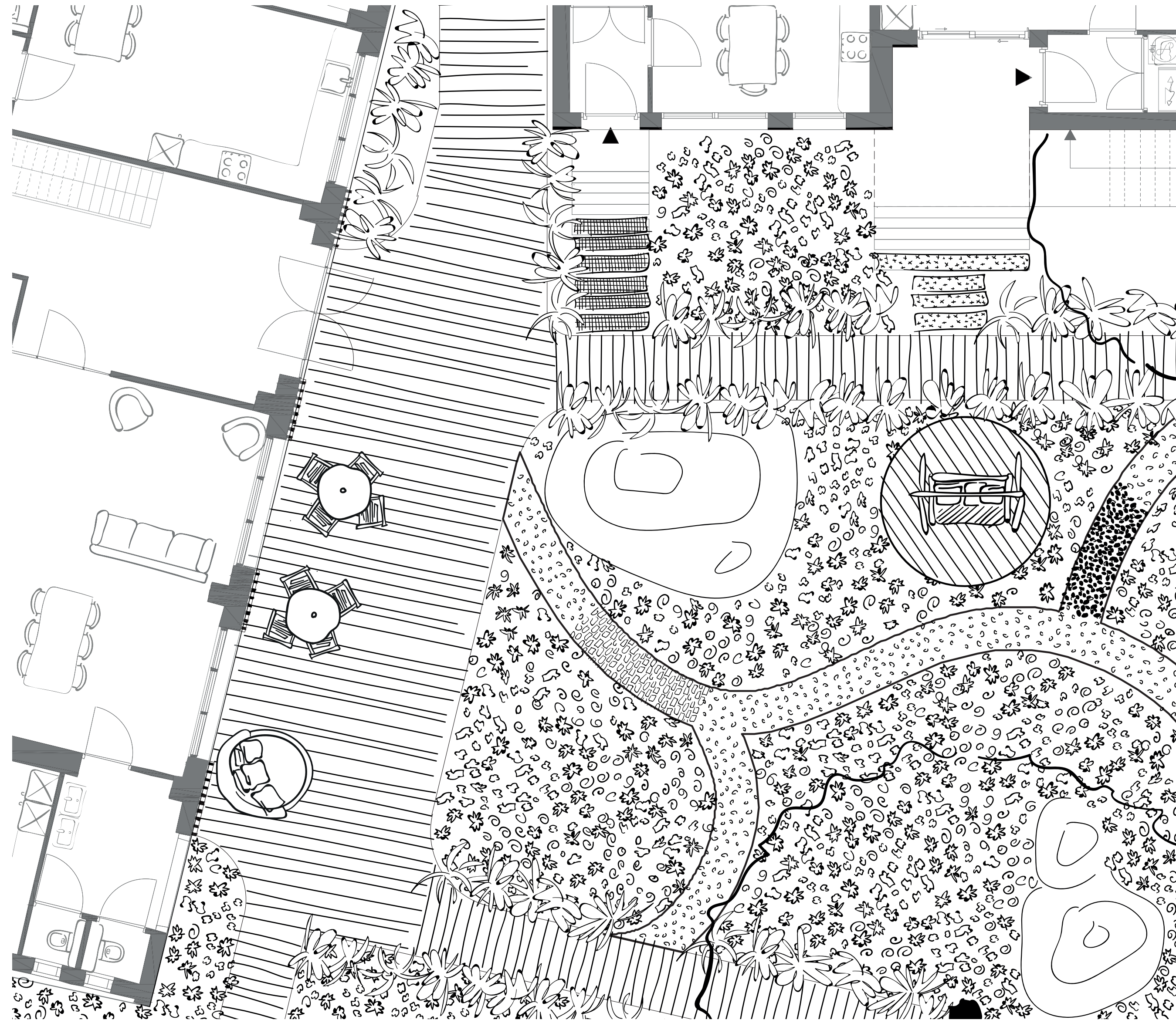

sound



light

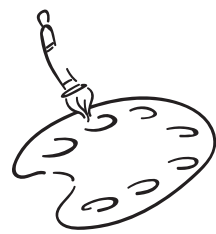

colour

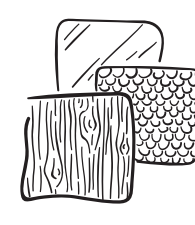

texture



smell



privacy

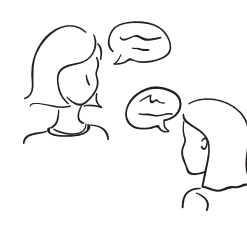

interaction

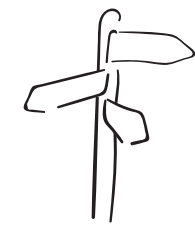

wayfinding

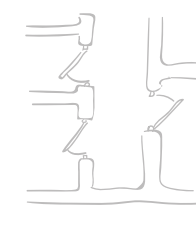

layout



personalisation



nature



comfort



routine



confidence

# exterior design

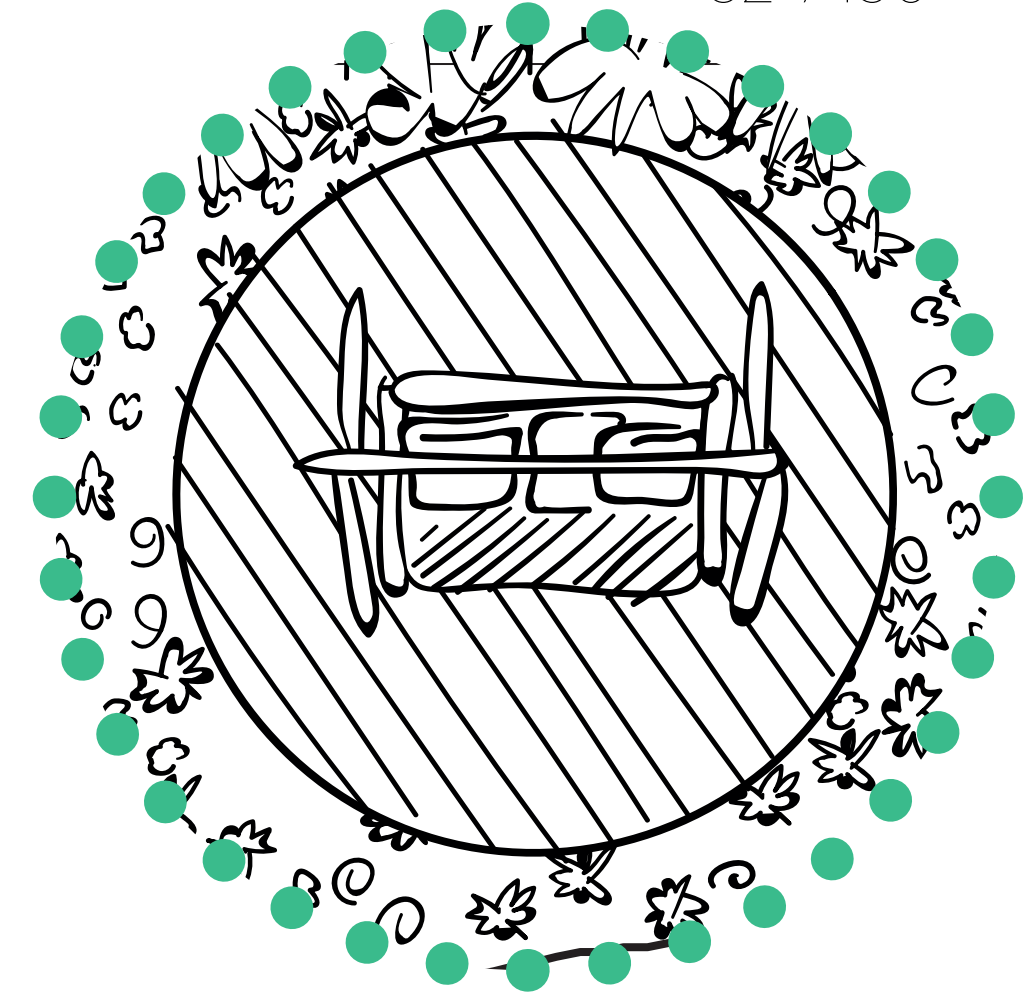
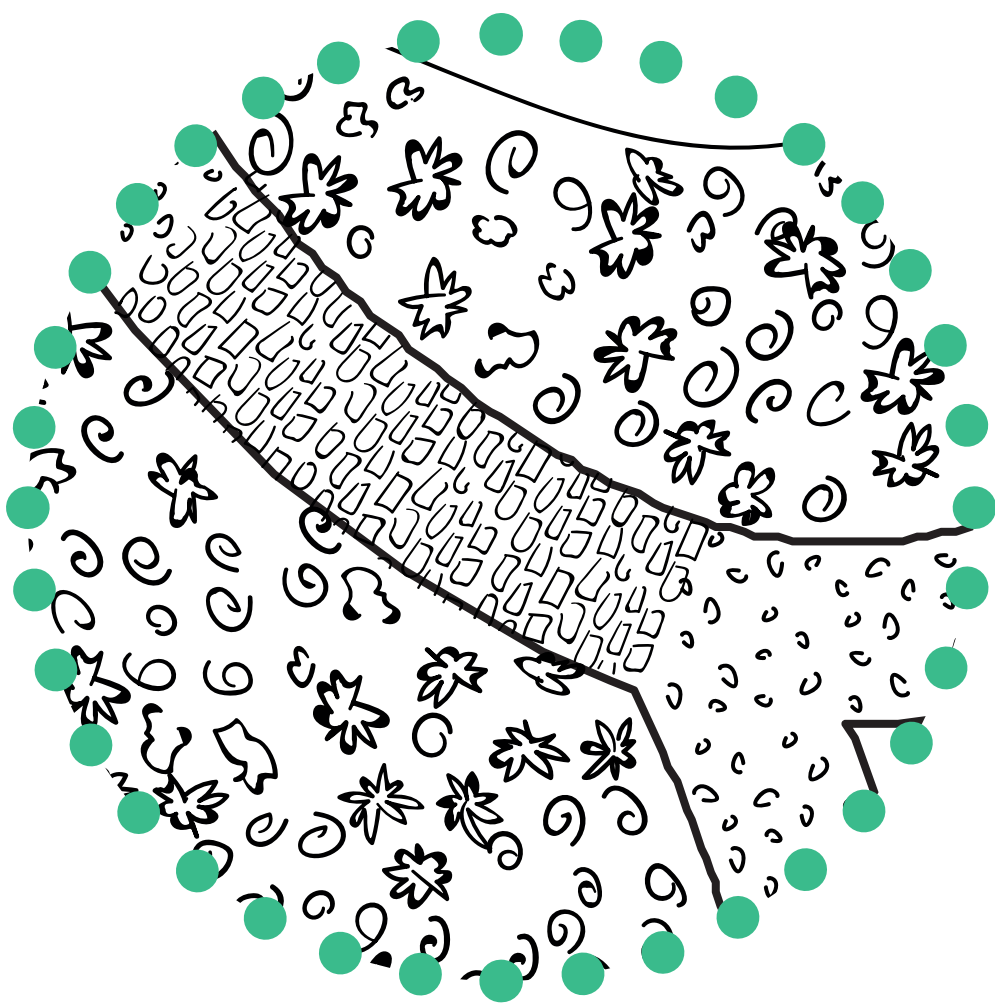
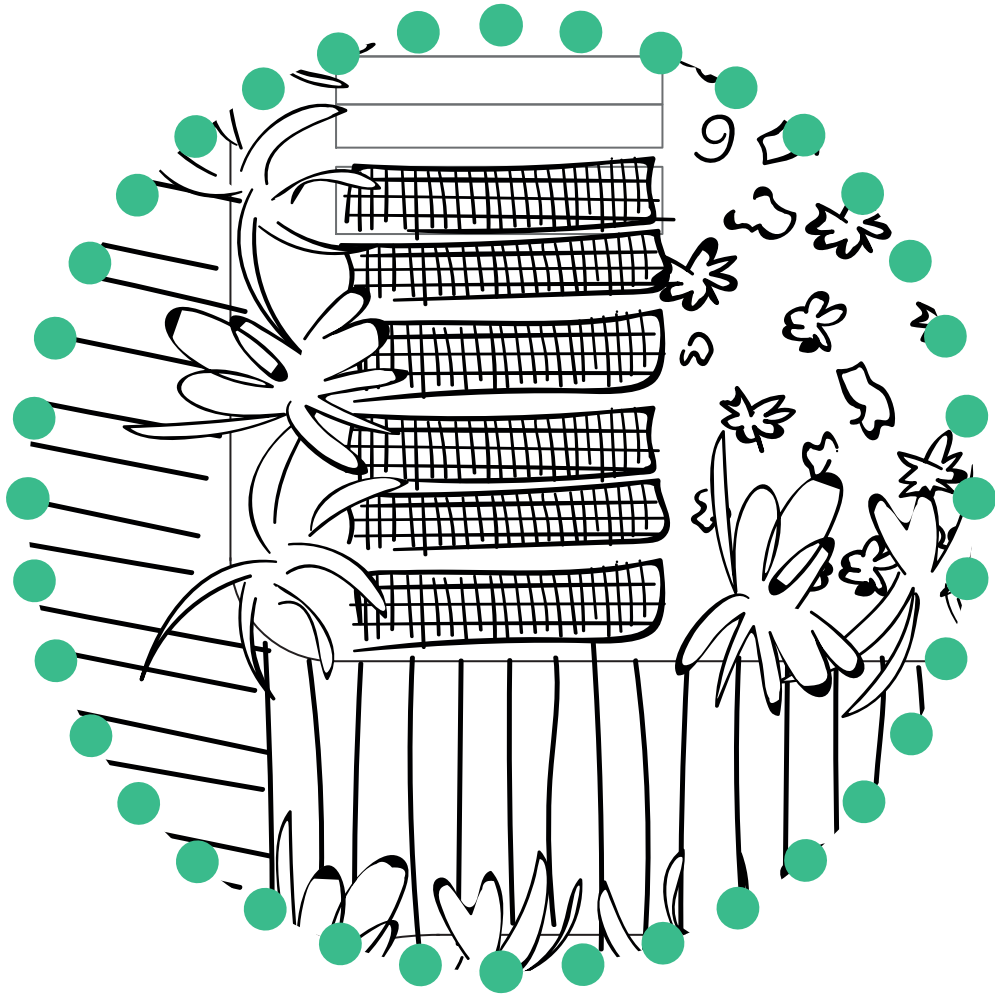

and the textural paths are really nice to walk on! Plus the planted herbs inbetween give off their scent.

personalised stepping stones enhance the personality of our dwellings!



sound



light



colour

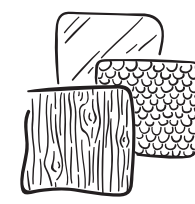

texture



smell



privacy



interaction

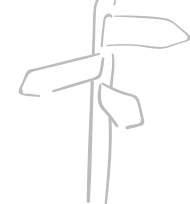

wayfinding

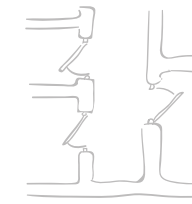

layout



personalisation



nature



comfort



routine



confidence

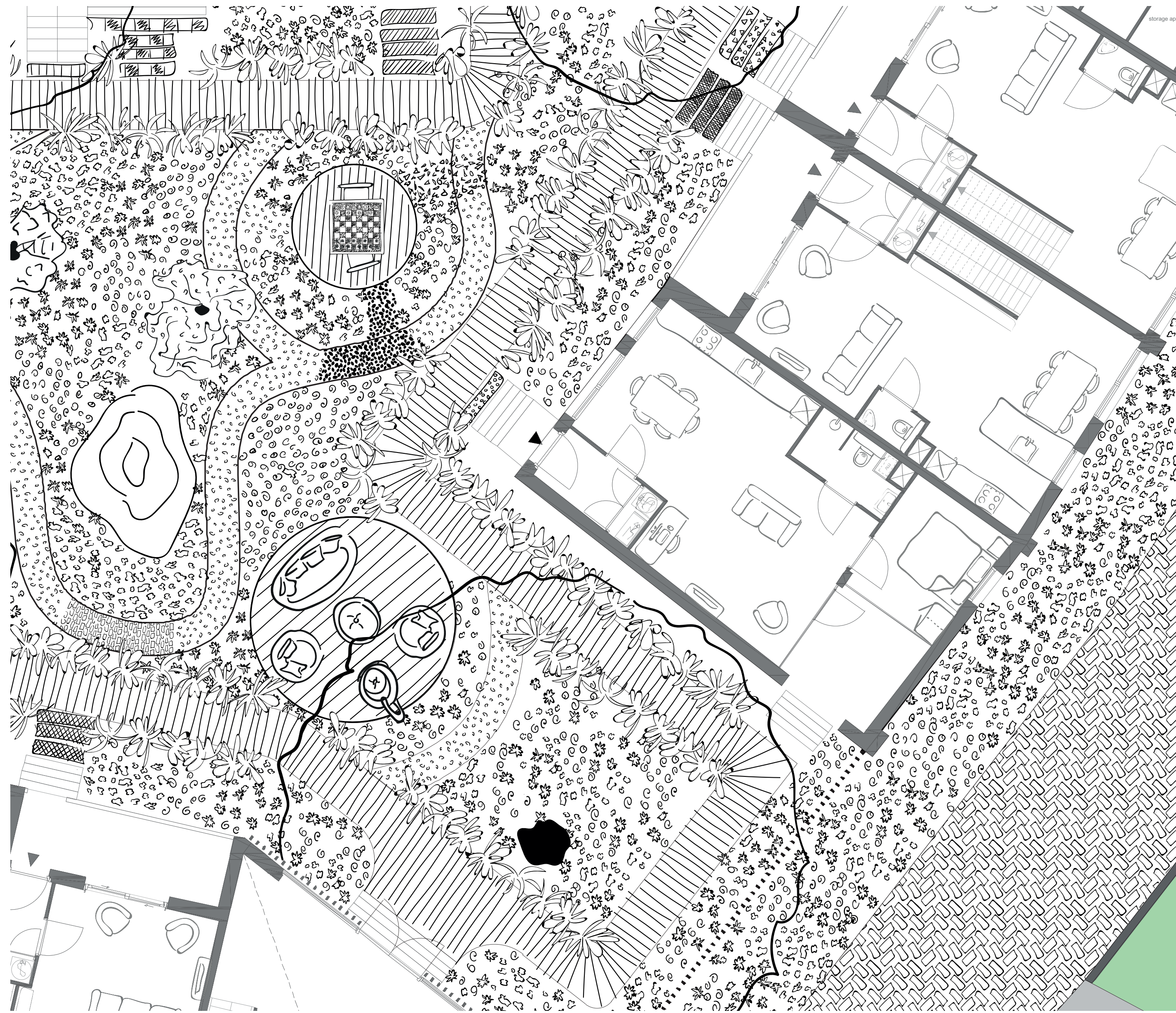

sound



light



colour

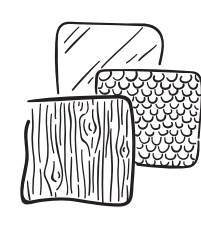

texture



smell



privacy

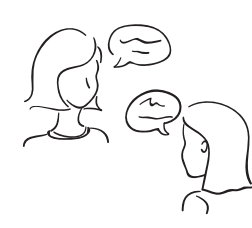

interaction

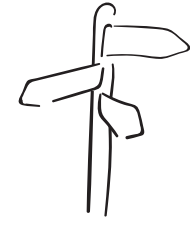

wayfinding

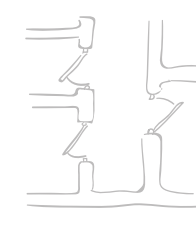

layout



personalisation



nature



comfort



routine



confidence

# exterior design

small hills with overhanging trees add to private places

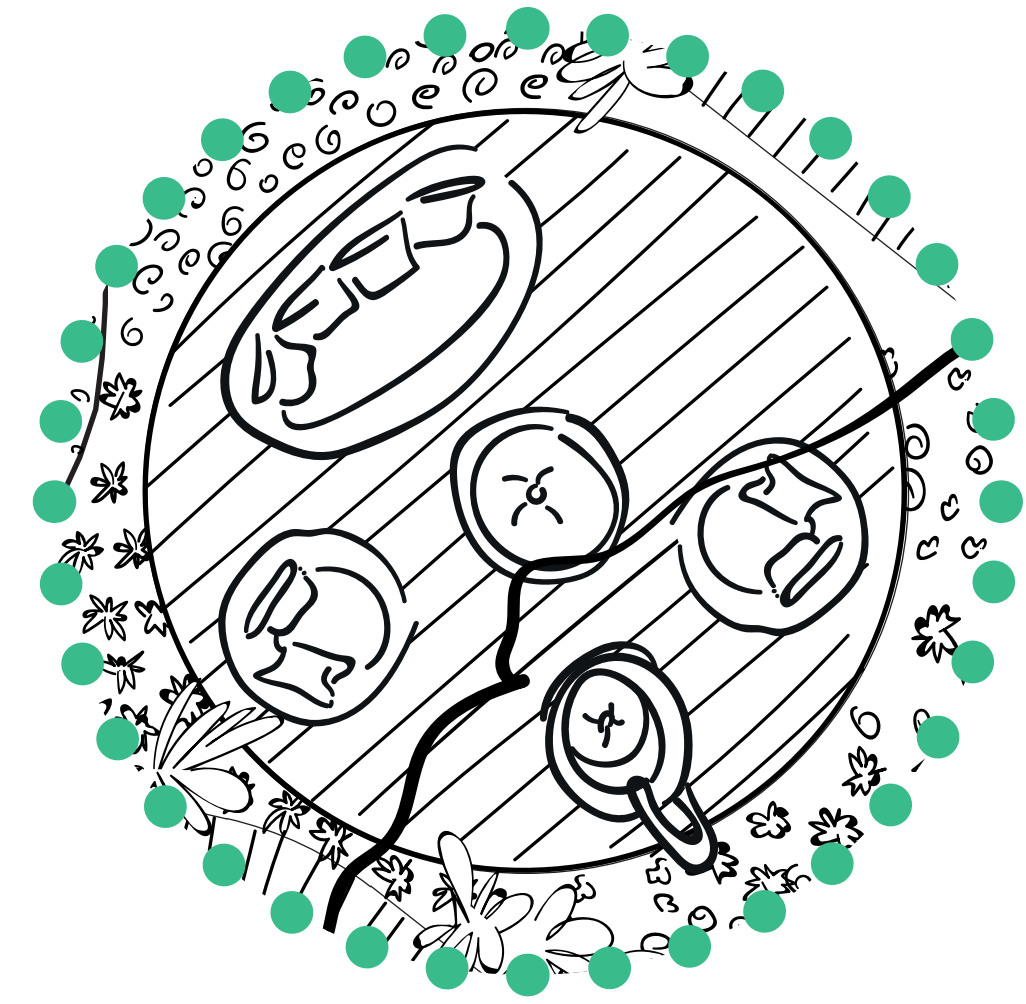
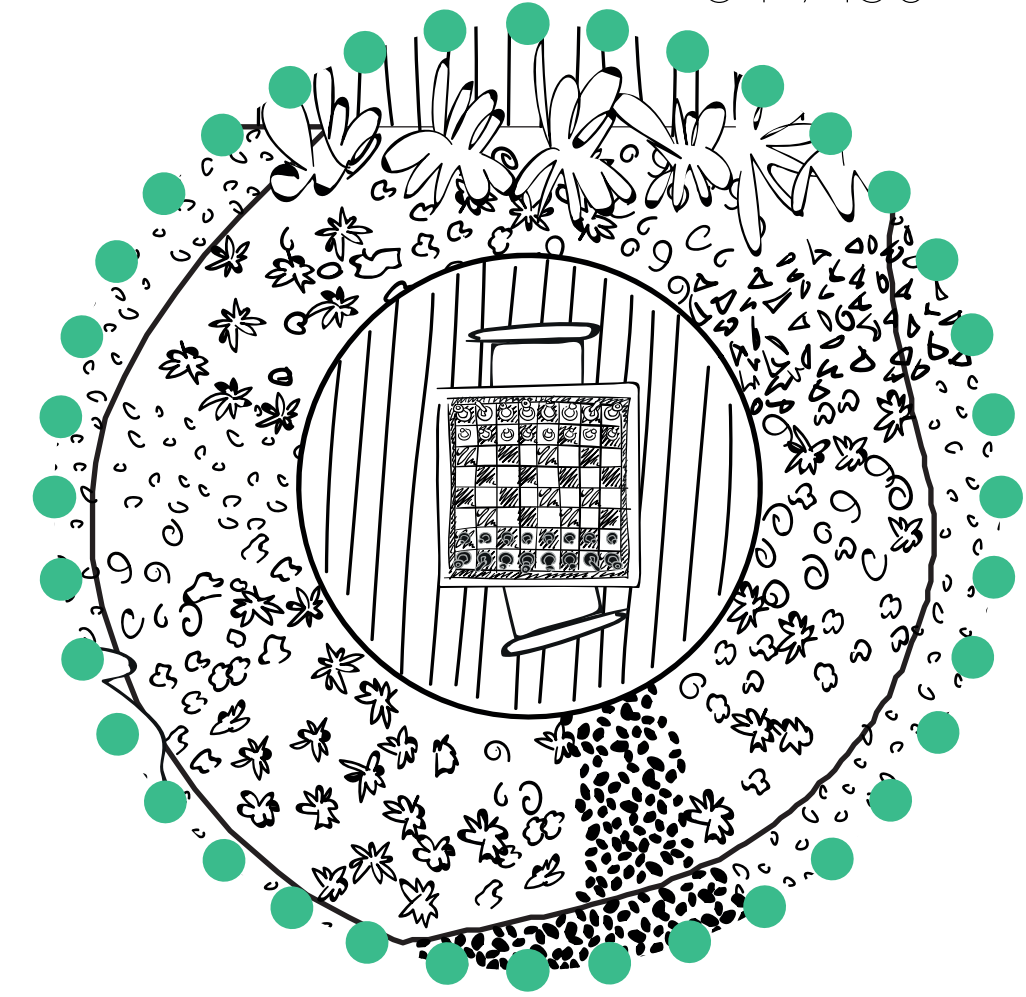
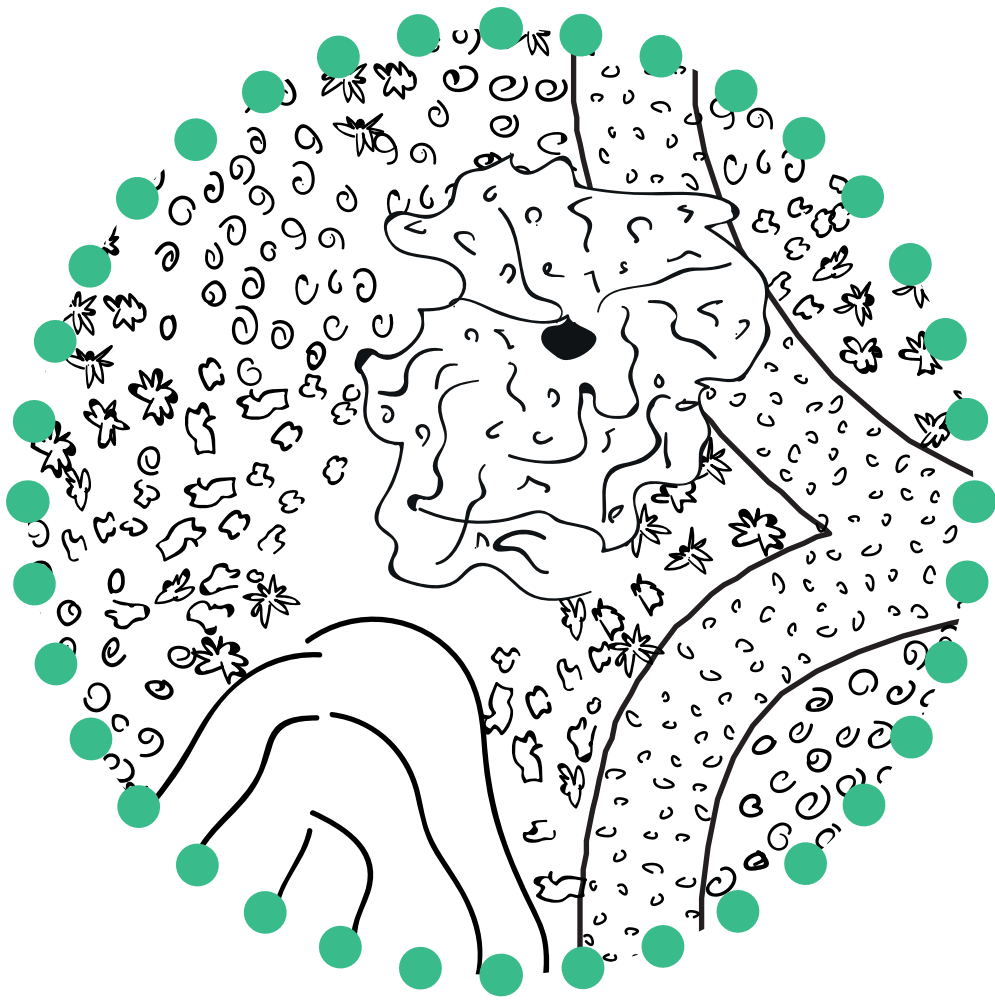

sound



light



colour

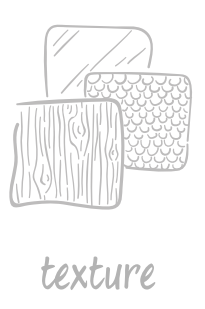

texture



smell



privacy

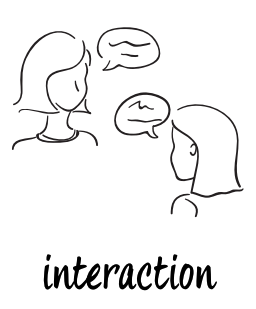

interaction



wayfinding



layout



personalisation

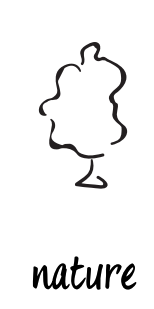

nature

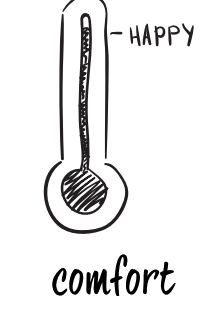

comfort



routine

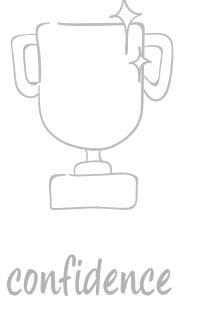

confidence



sound



light

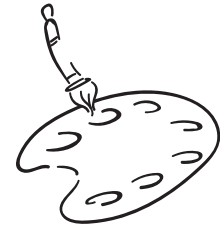

colour

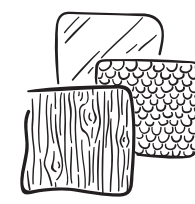

texture



smell



privacy



interaction

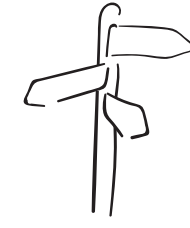

wayfinding

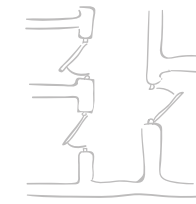

layout



personalisation



nature



comfort



routine



confidence



Fragrant plants like lilies and freesia's give off their scents.

and the herb garden can be used for the common room

- sound
- light
- colour
- texture
- smell
- privacy
- interaction
- wayfinding
- layout
- personalisation
- nature
- comfort
- routine
- confidence



sound



light

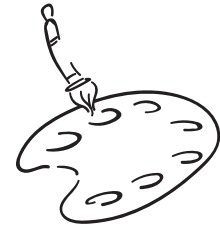

colour

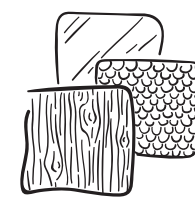

texture



smell



privacy



interaction

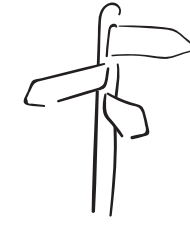

wayfinding

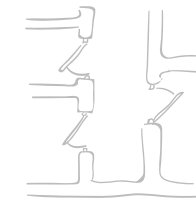

layout



personalisation



nature

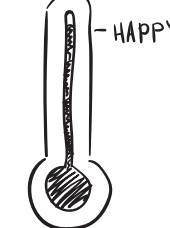

comfort



routine



confidence

# exterior design



a wisteria tree is very colourful, fragrant and has cascading petals

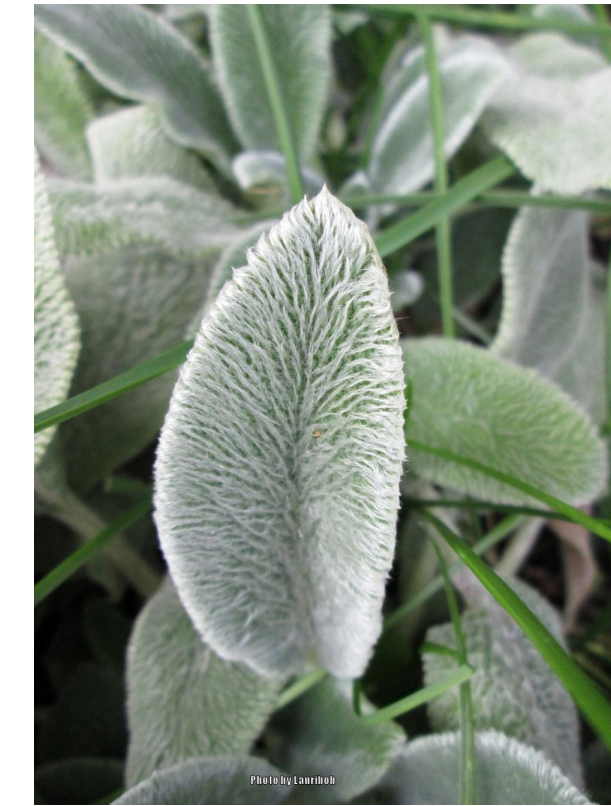

the leaves of lambs ear are very soft ...

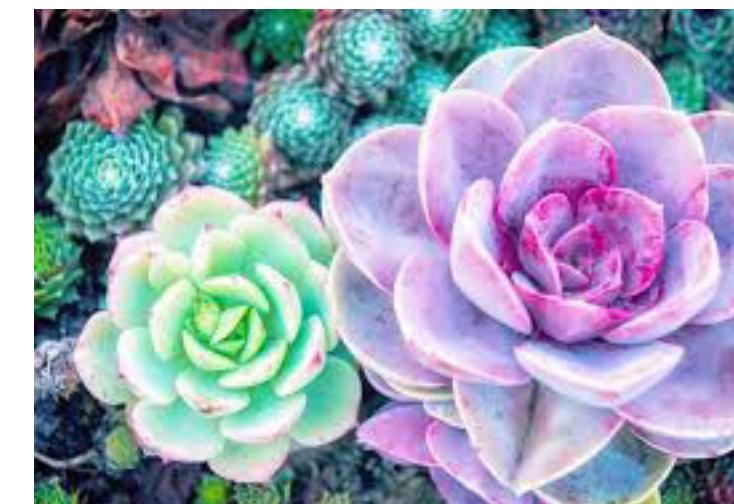

... while succulents are smooth to the touch.



sound



light

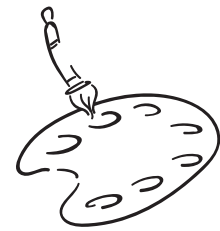

colour

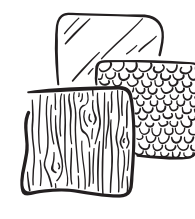

texture



smell



privacy



interaction

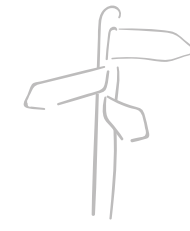

wayfinding



layout



personalisation



nature

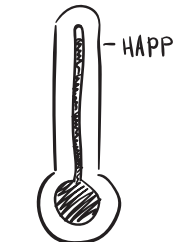

comfort



routine



confidence





sound



light

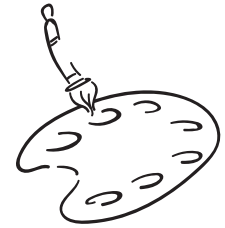

colour

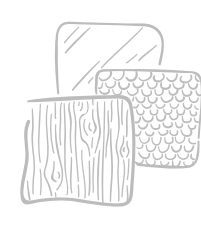

texture



smell



privacy

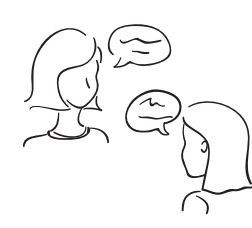

interaction

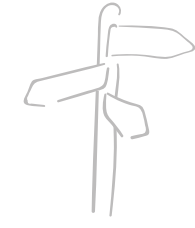

wayfinding

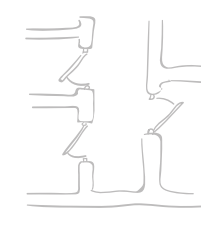

layout



personalisation



nature



comfort



routine



confidence



a playground will be added ...

... as well as urban seating to enjoy the weather and each other!



sound



light



colour

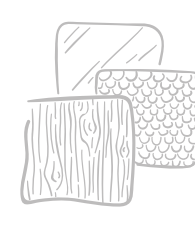

texture



smell



privacy

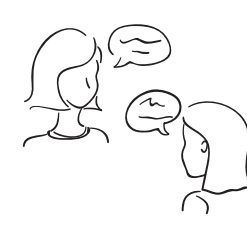

interaction

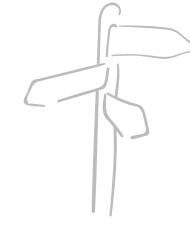

wayfinding

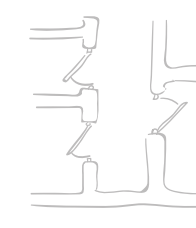

layout



personalisation



nature



comfort



routine



confidence

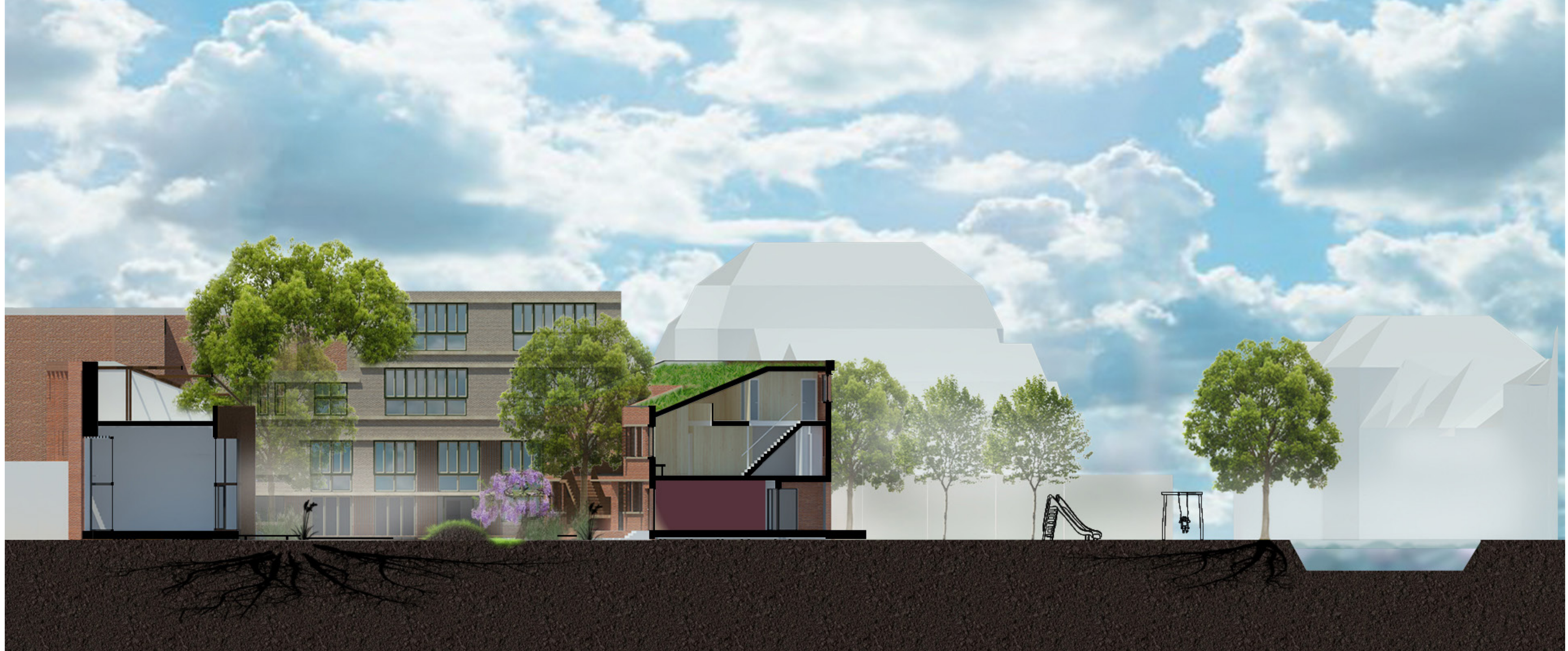

sound



light

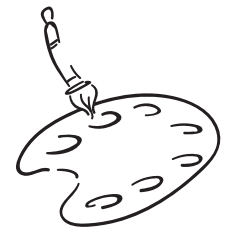

colour

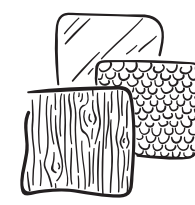

texture



smell



privacy



interaction



wayfinding

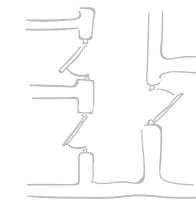

layout



personalisation



nature

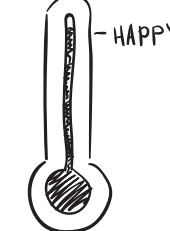

comfort



routine

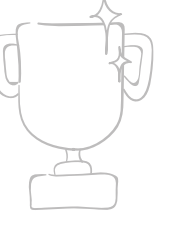

confidence

Let's have a closer look at the building's construction!



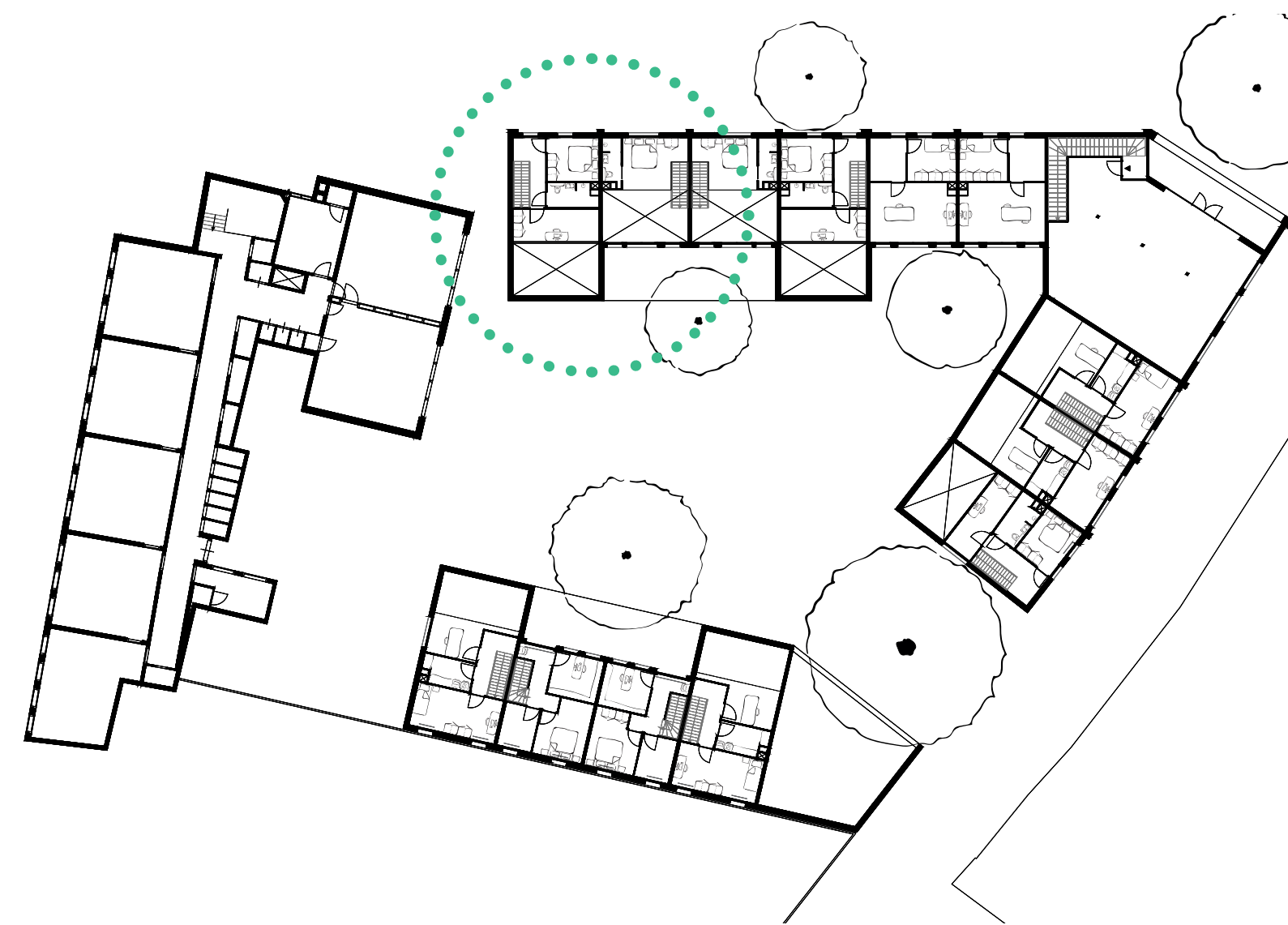
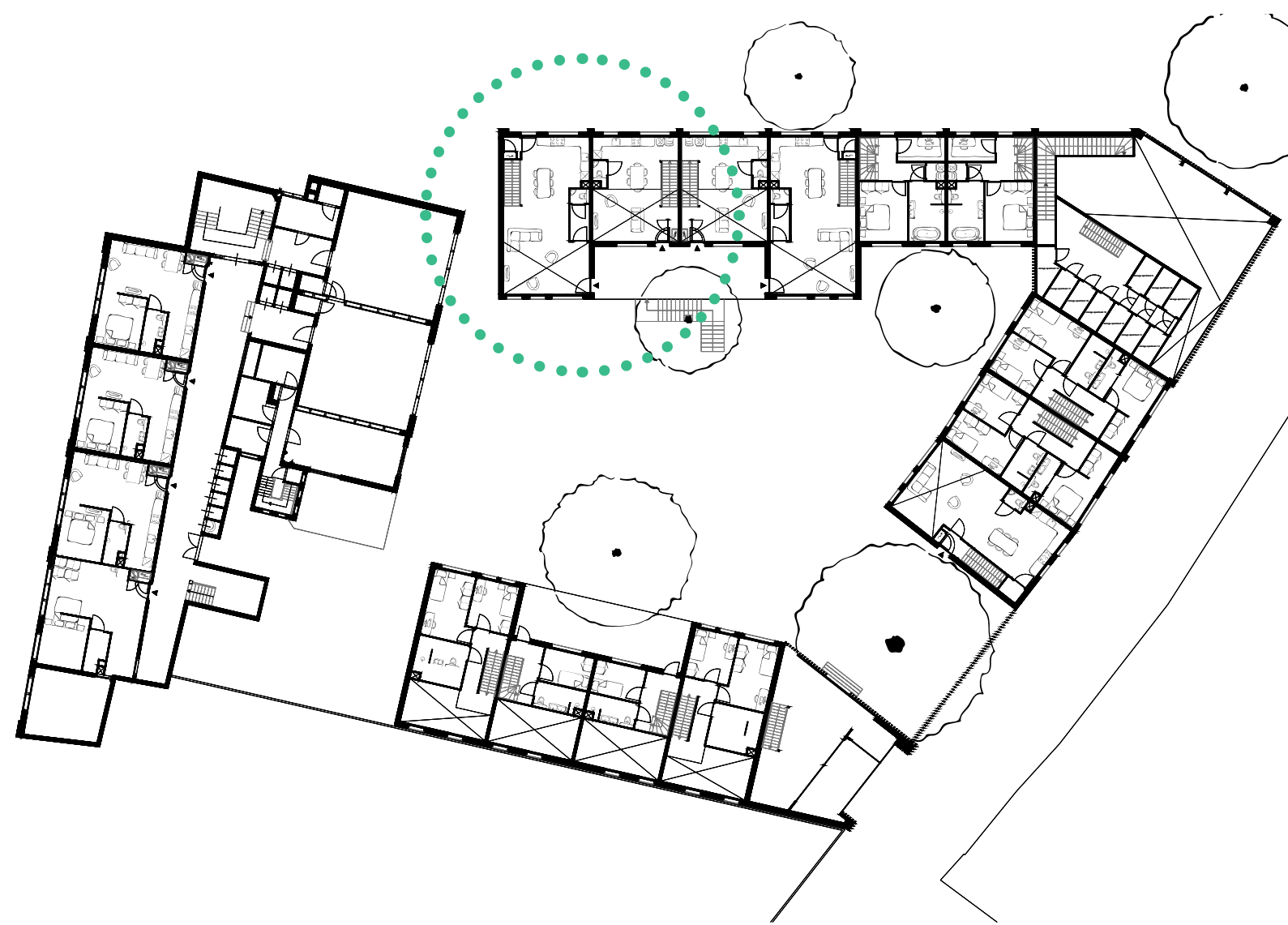

sound



light



colour

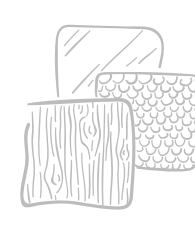

texture



smell



privacy

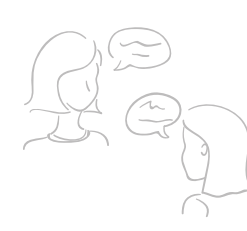

interaction



wayfinding

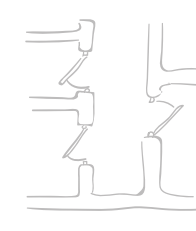

layout



personalisation



nature



comfort

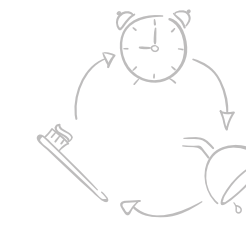

routine



confidence

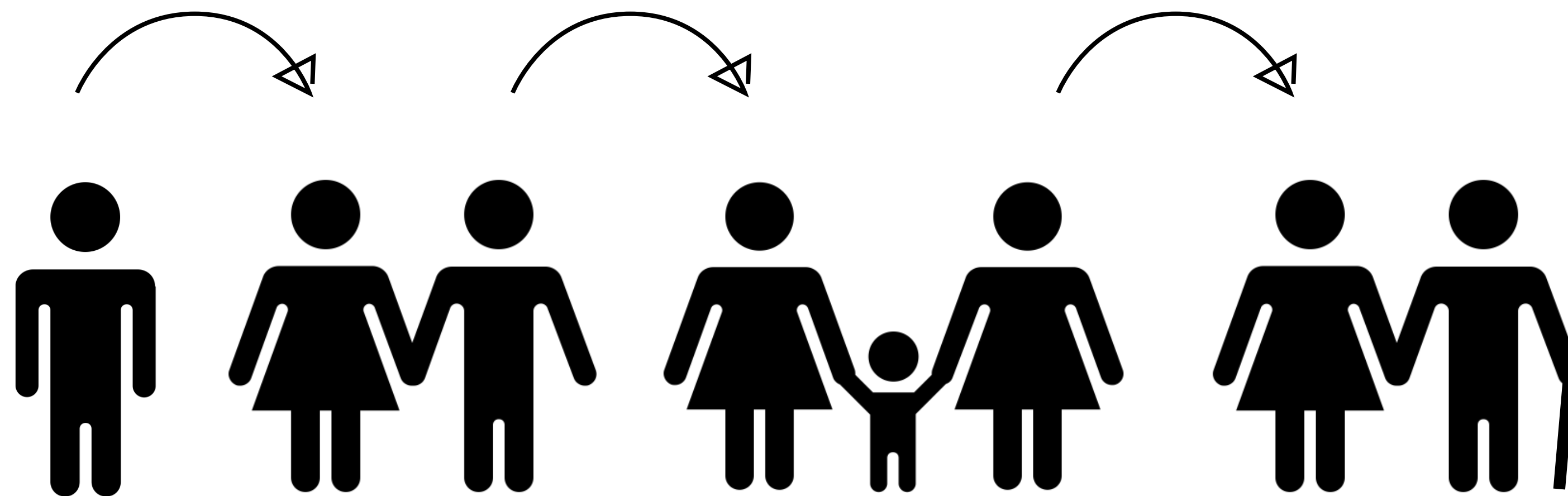

sound



light



colour

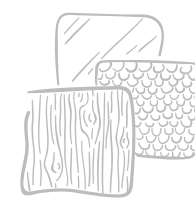

texture



smell



privacy



interaction

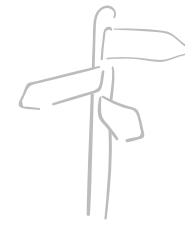

wayfinding

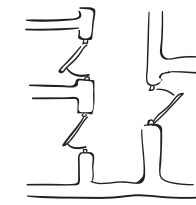

layout



personalisation



nature

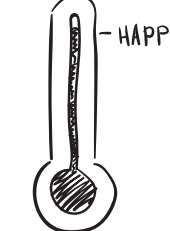

comfort

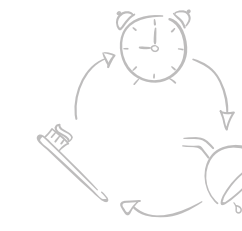

routine



confidence

helical screw piles  
disturb the ground  
as little as possible

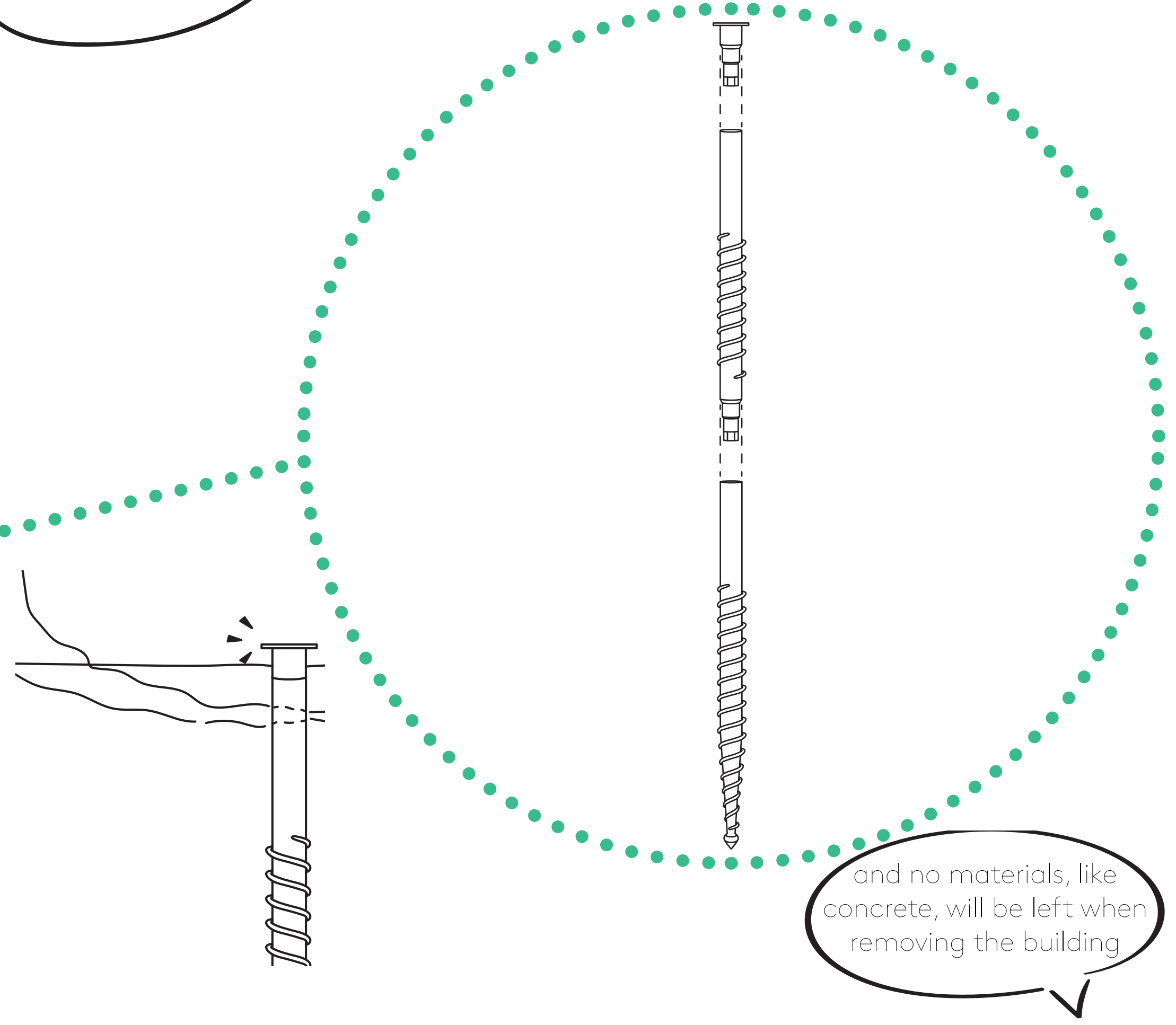
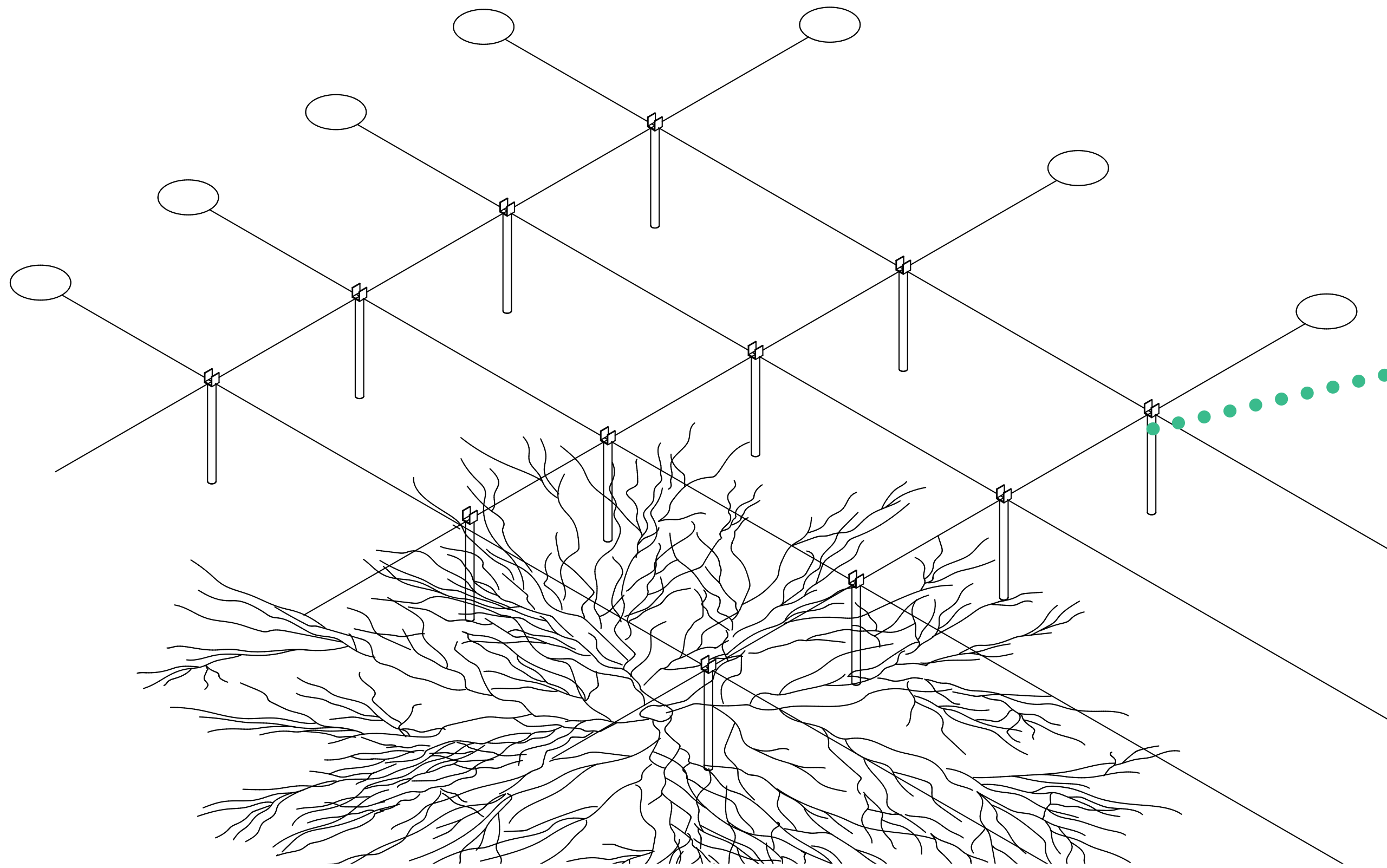

sound



light



colour

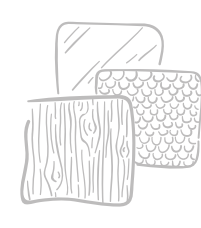

texture



smell



privacy



interaction

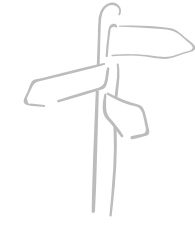

wayfinding

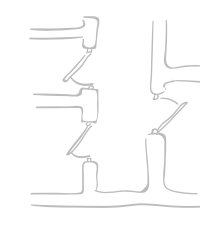

layout



personalisation



nature



comfort



routine



confidence

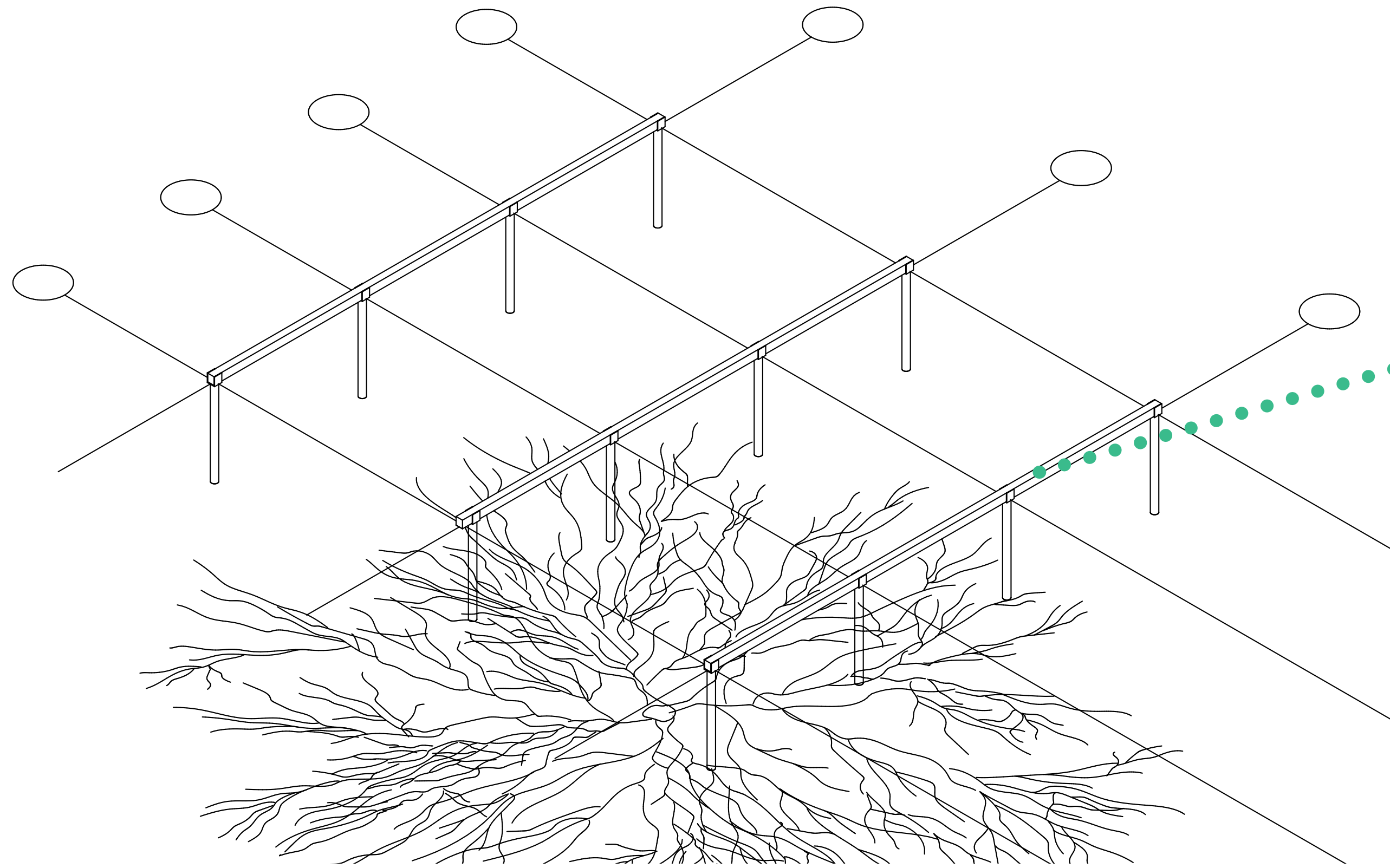

sound



light



colour

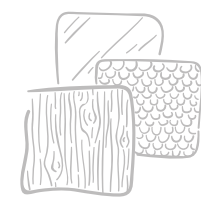

texture



smell



privacy



interaction

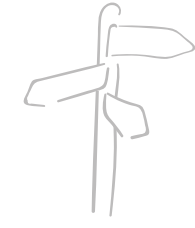

wayfinding



layout

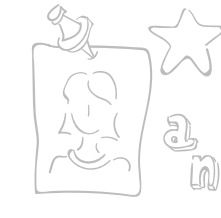

personalisation



nature



comfort



routine



confidence



CLT is an easy, quick, and lightweight building method.

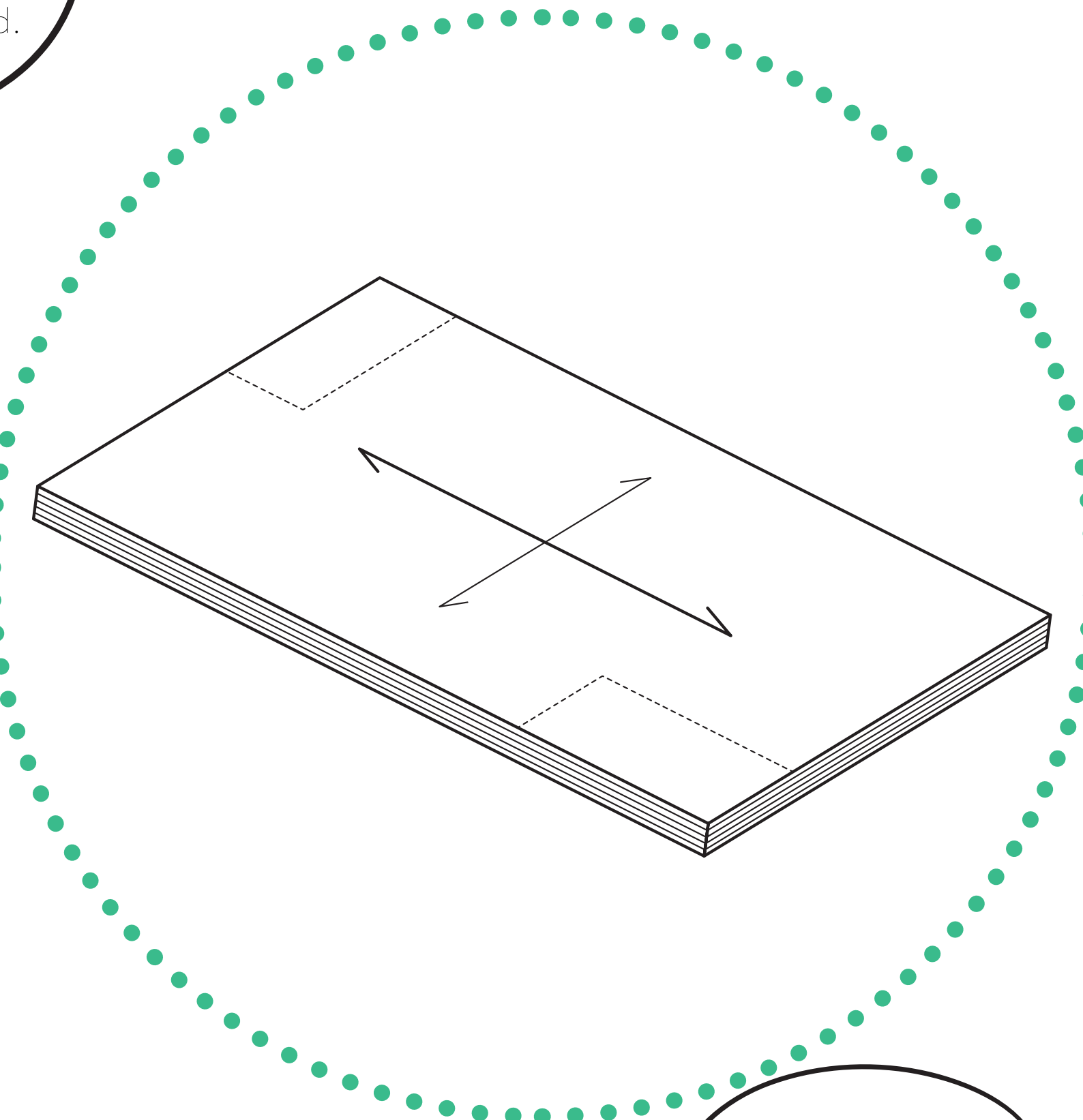
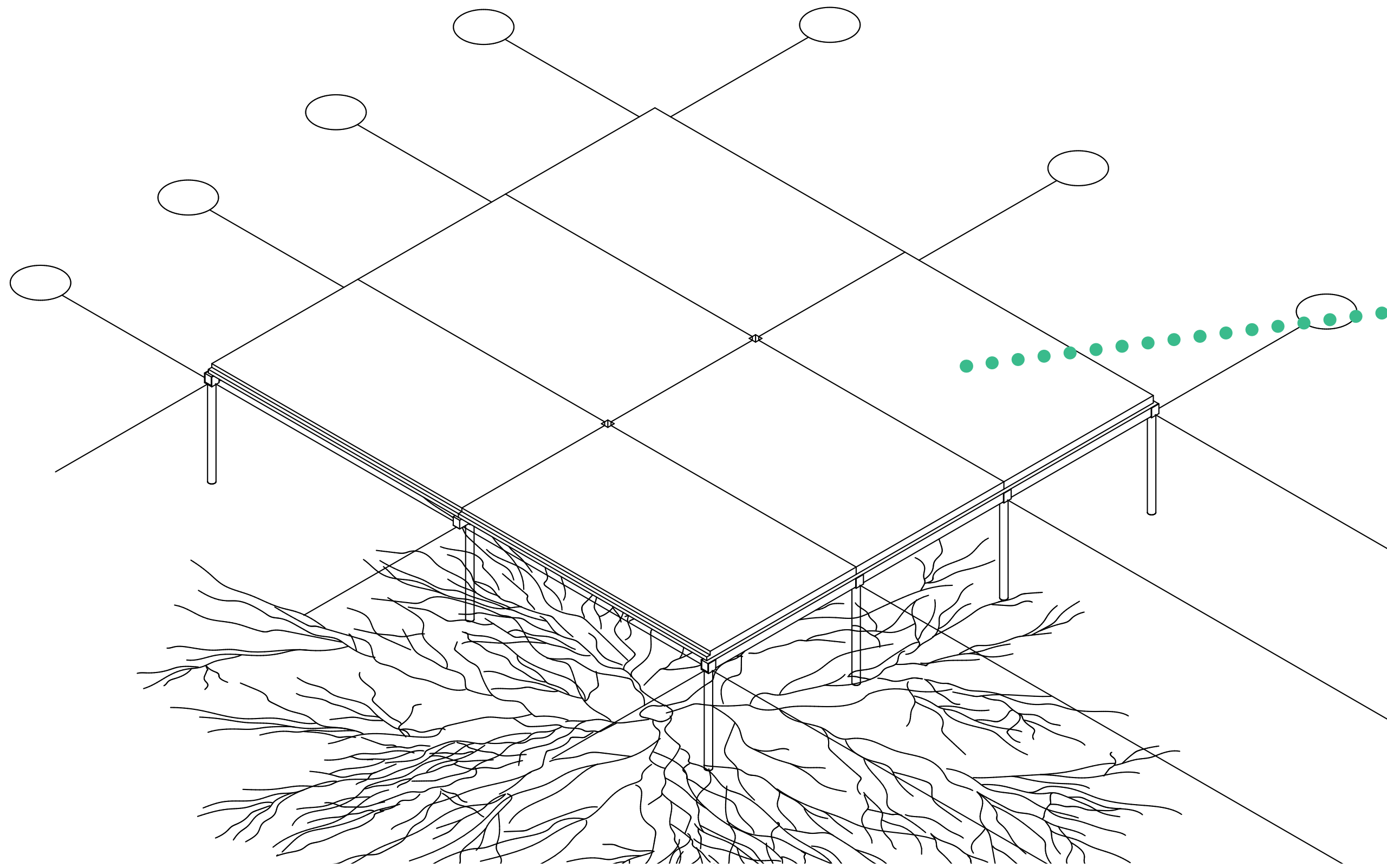

it provides a high amount of flexibility



sound



light



colour

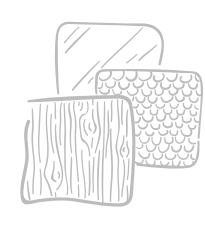

texture



smell



privacy



interaction

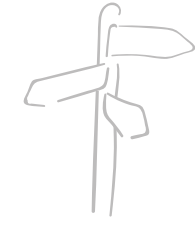

wayfinding

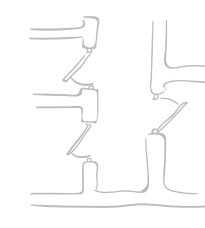

layout



personalisation



nature



comfort



routine



confidence

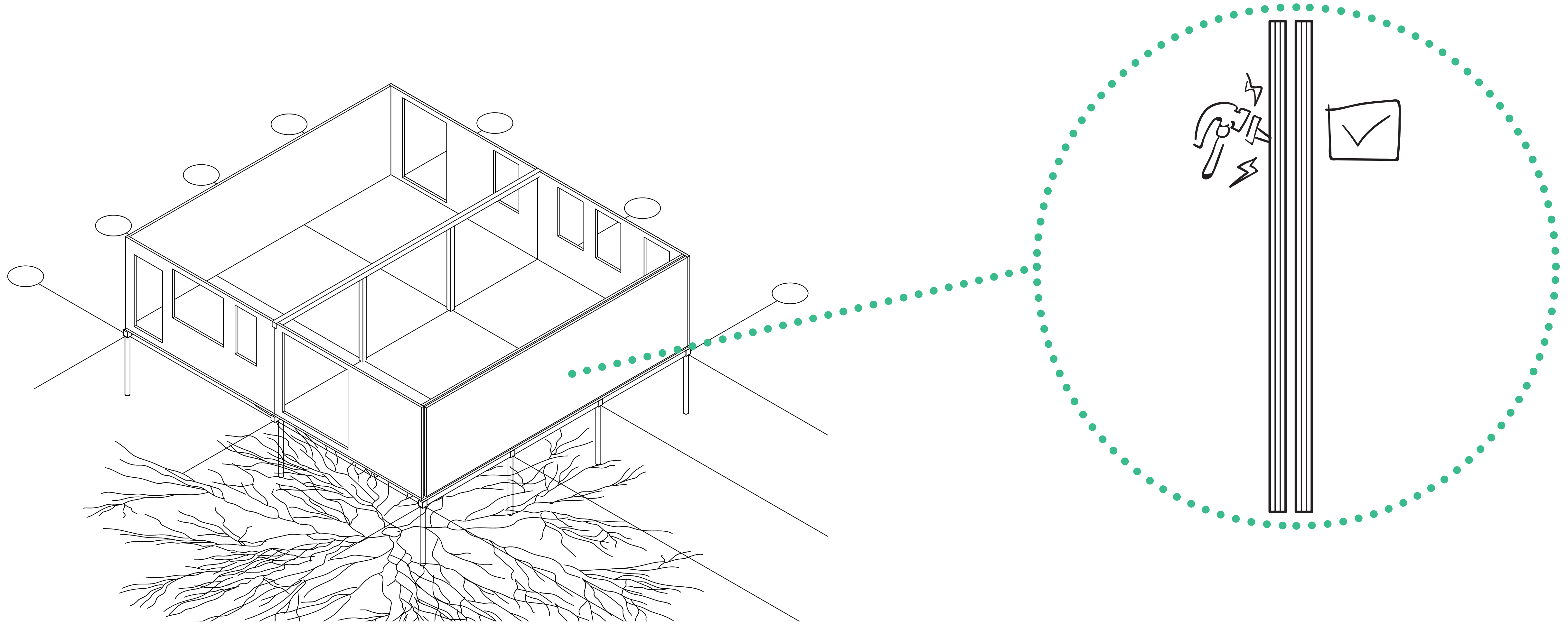

sound



light



colour



texture



smell



privacy



interaction

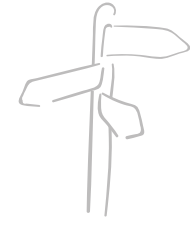

wayfinding



layout



personalisation



nature



comfort



routine



confidence

here, columns  
make up for the  
dividing wall...

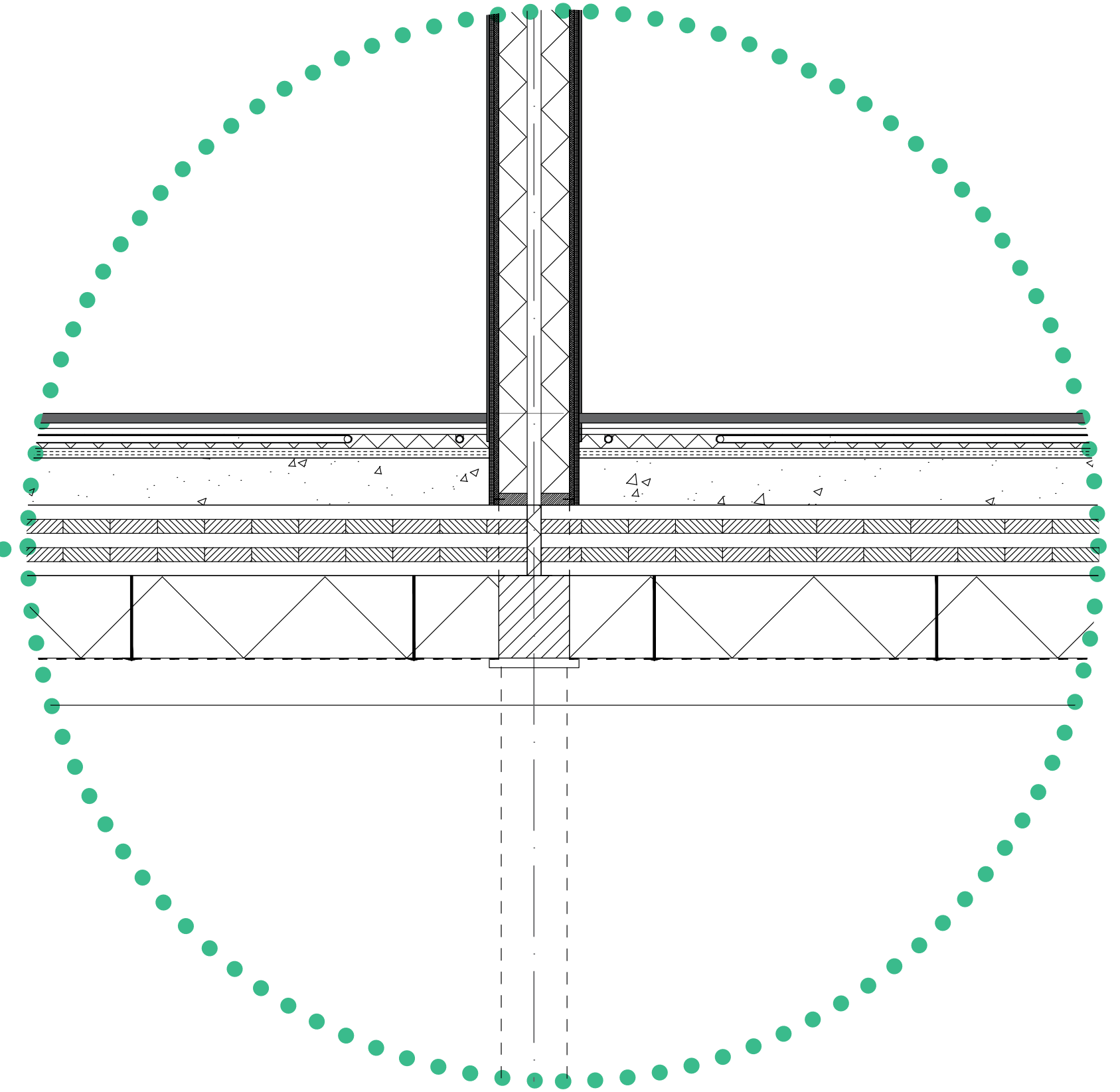
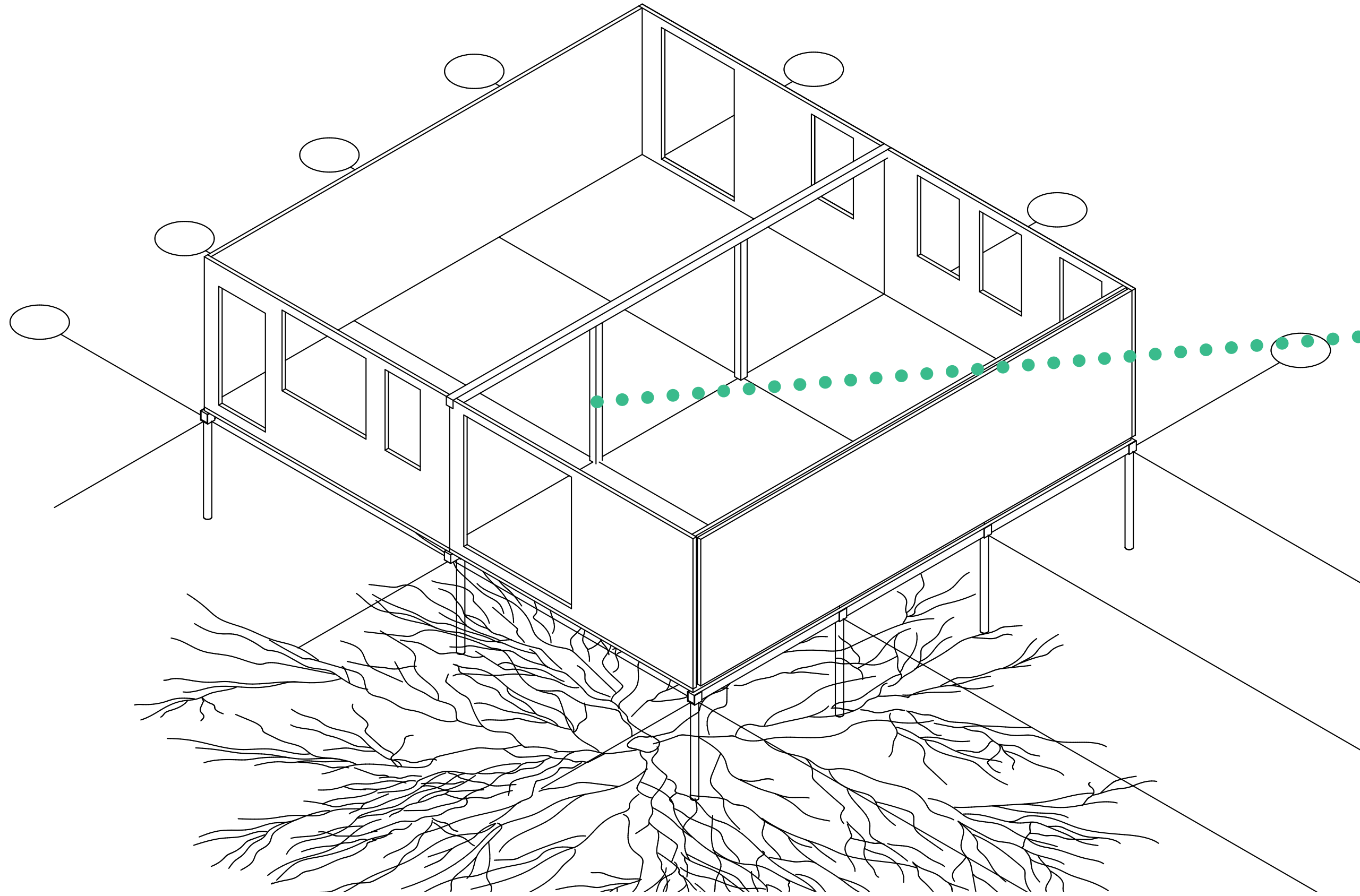

sound



light



colour

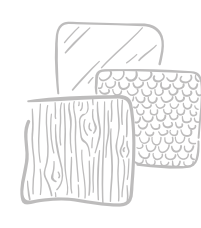

texture



smell



privacy



interaction

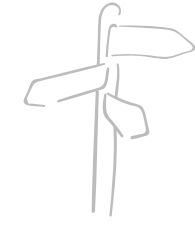

wayfinding

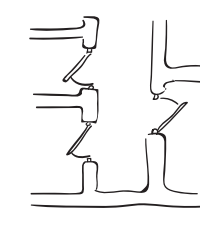

layout

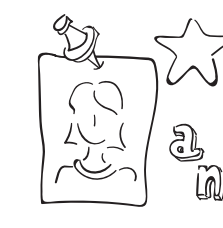

personalisation



nature



comfort



routine



confidence

which provides the option to expand the dwellings...

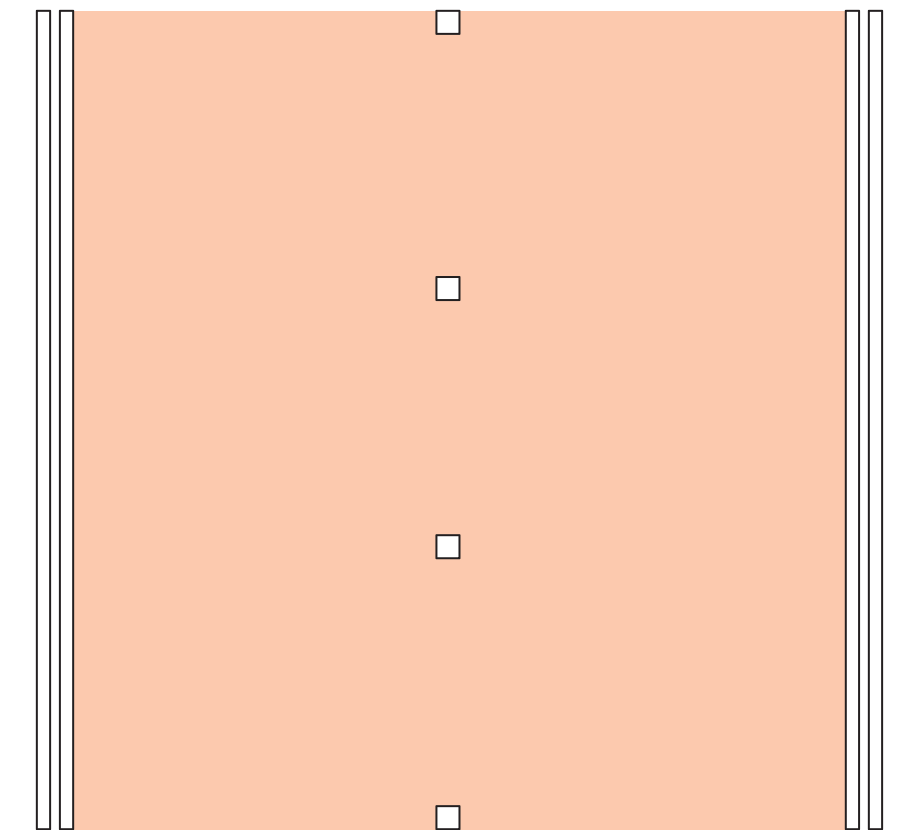
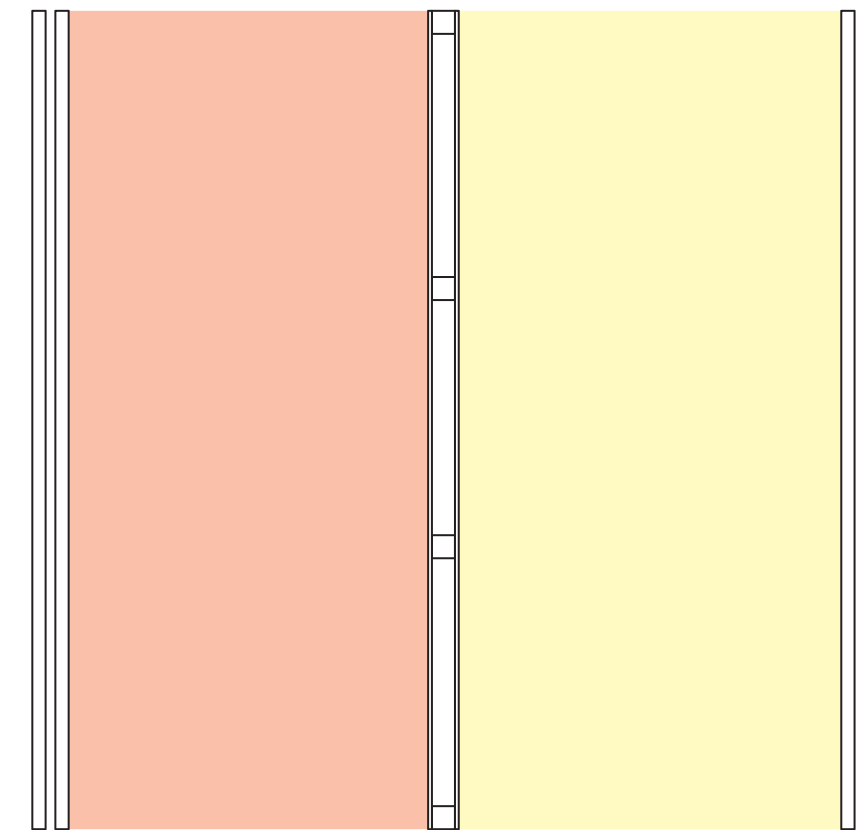
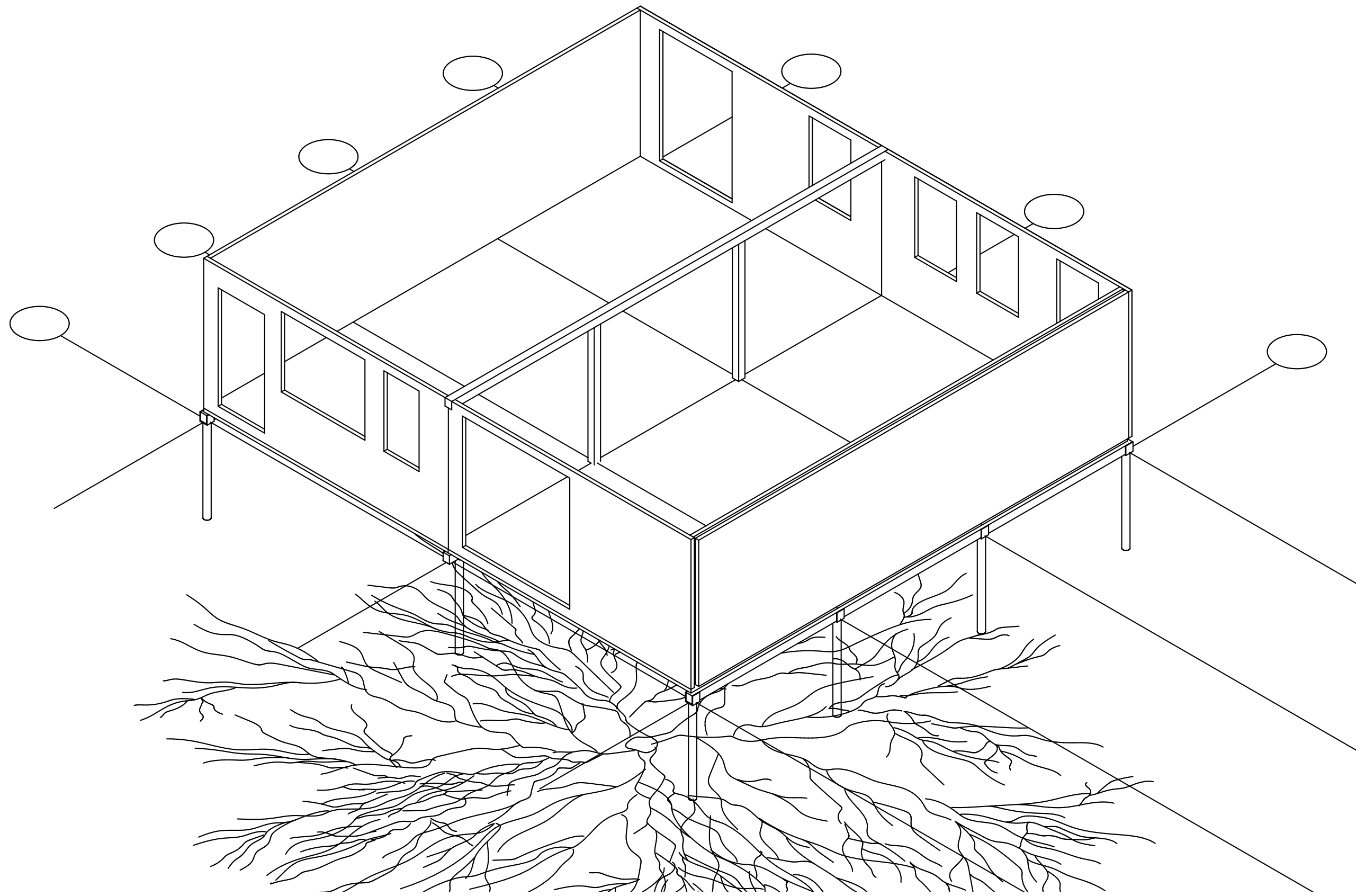

... in the case of changing needs! Maybe it can develop to a group home.



sound



light



colour

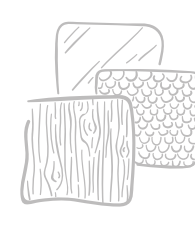

texture



smell



privacy

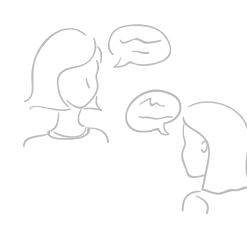

interaction

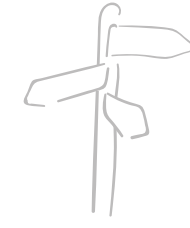

wayfinding



layout



personalisation



nature



comfort



routine



confidence

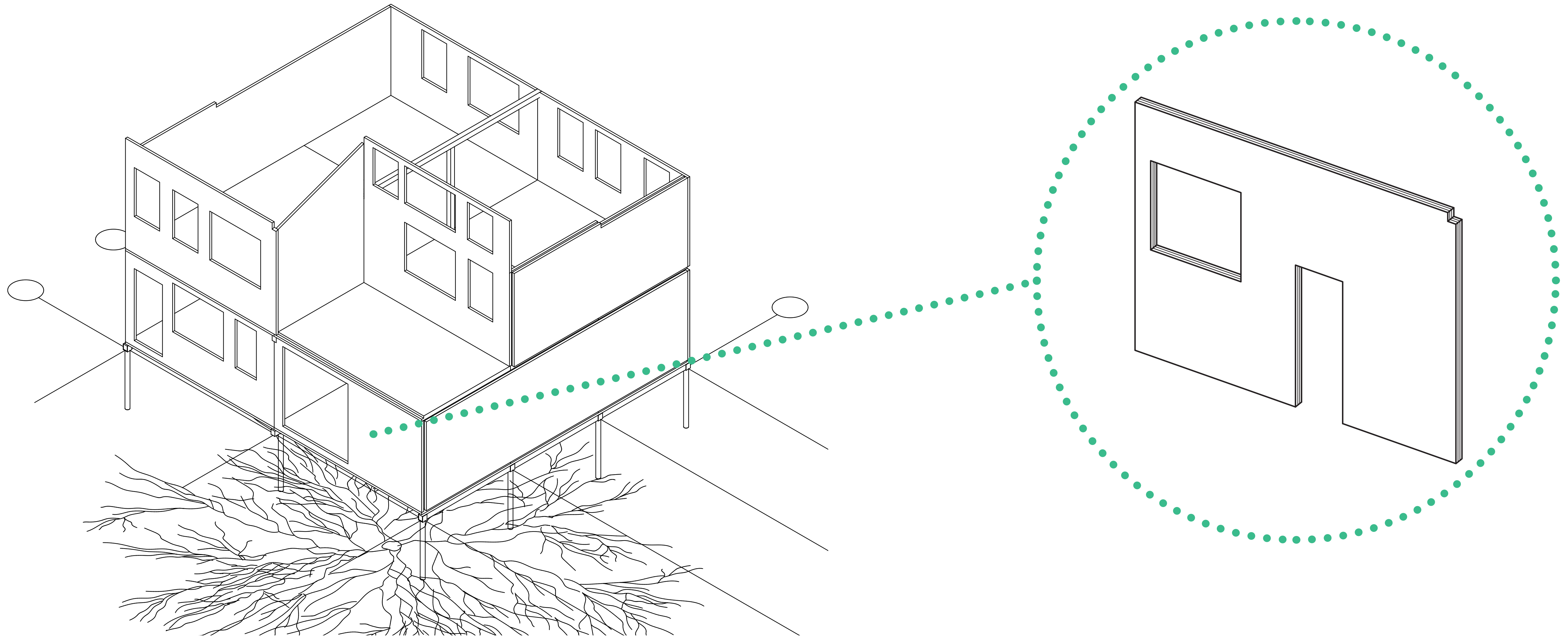

sound



light



colour

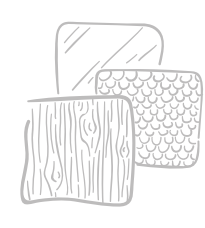

texture



smell



privacy



interaction

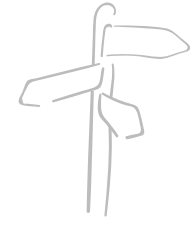

wayfinding



layout

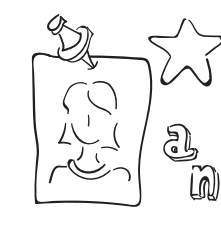

personalisation



nature



comfort



routine



confidence

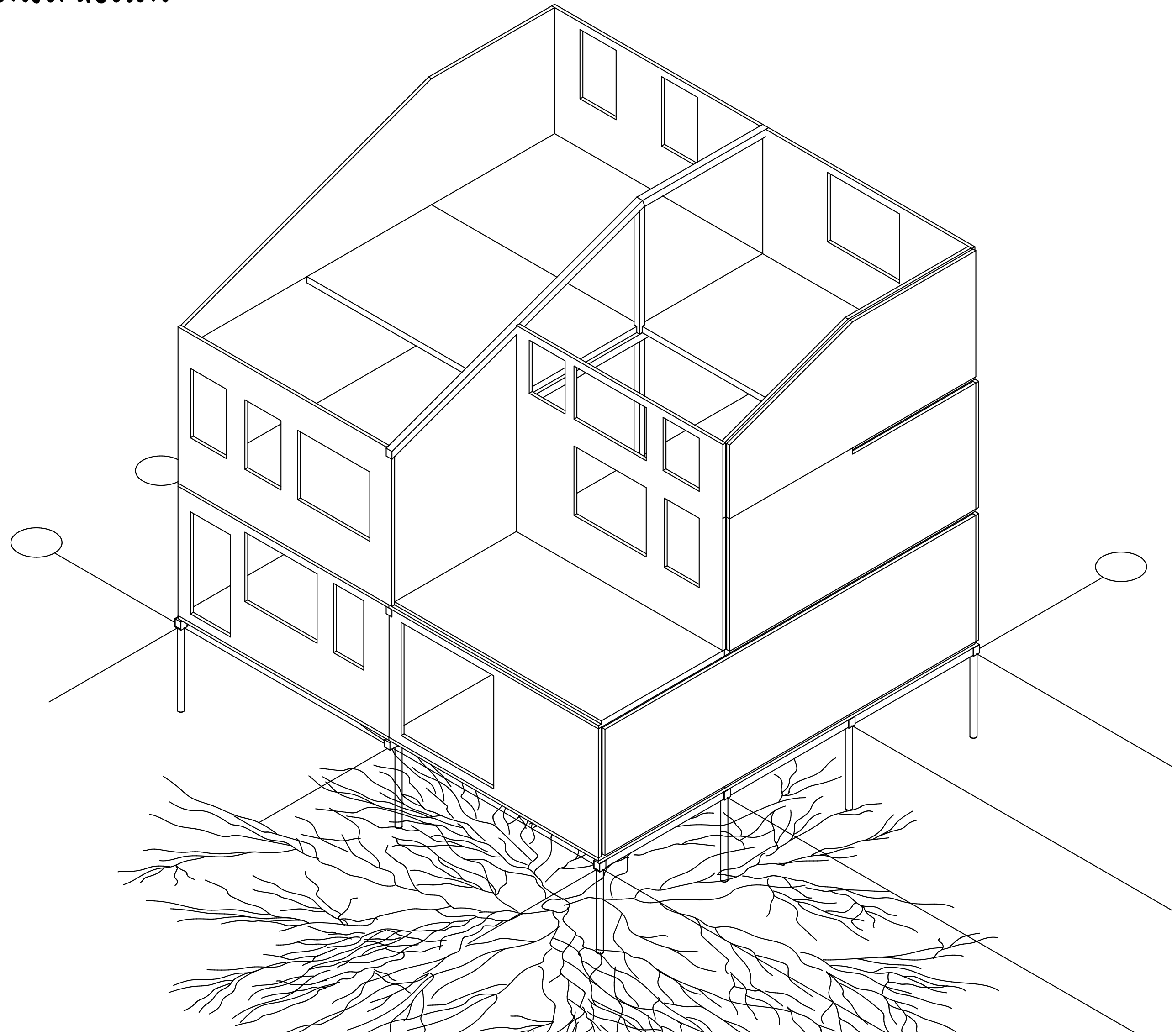

CLT provides also an esthetic aspect, since it can be applied unfinished.



CLT type A (sight)  
small knots with a max. size of 40 mm



sound



light



colour

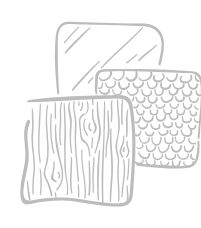

texture



smell



privacy



interaction

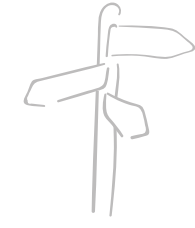

wayfinding

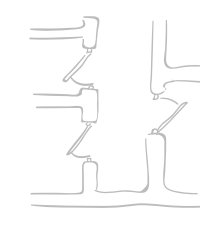

layout



personalisation



nature



comfort



routine



confidence

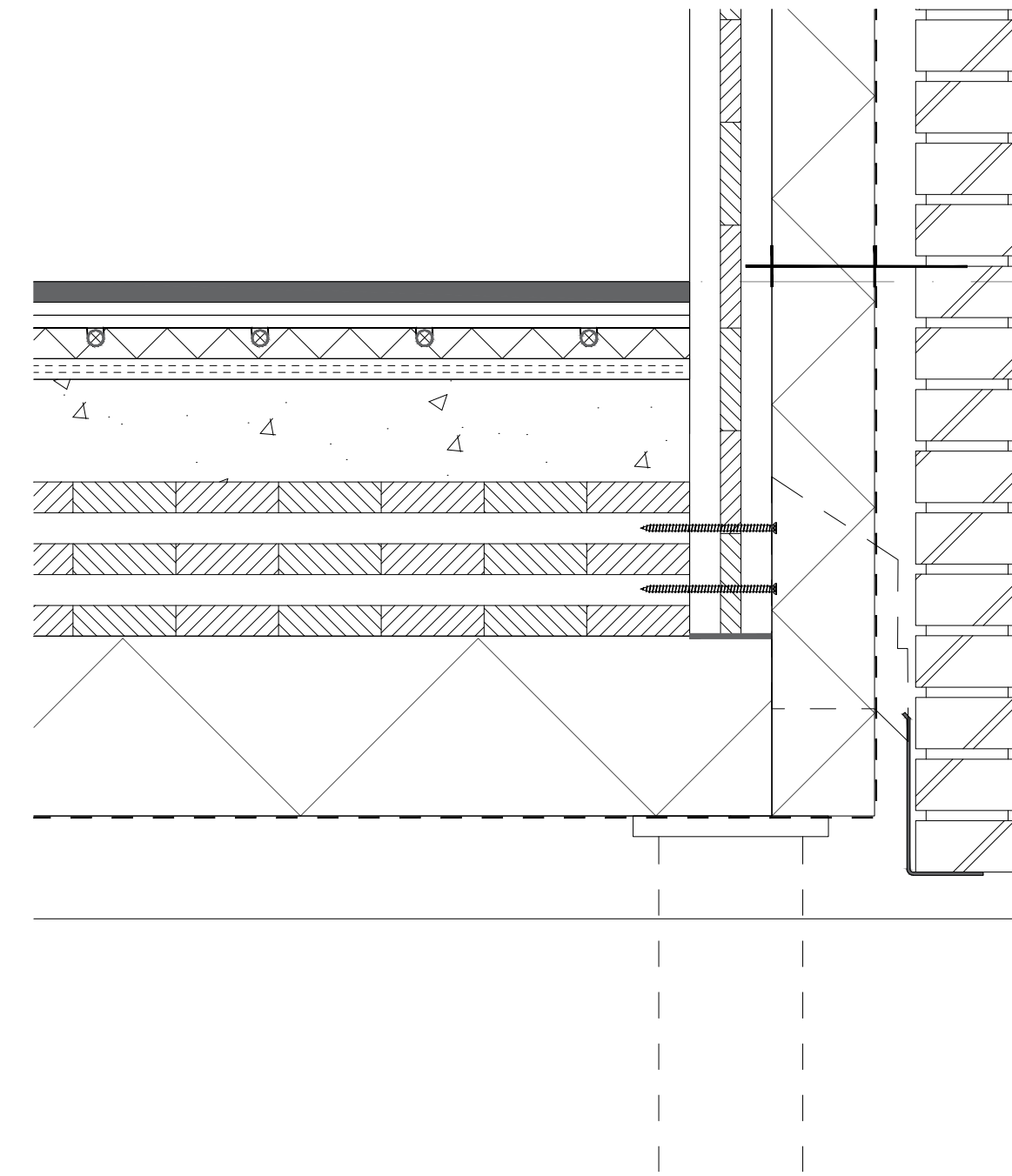
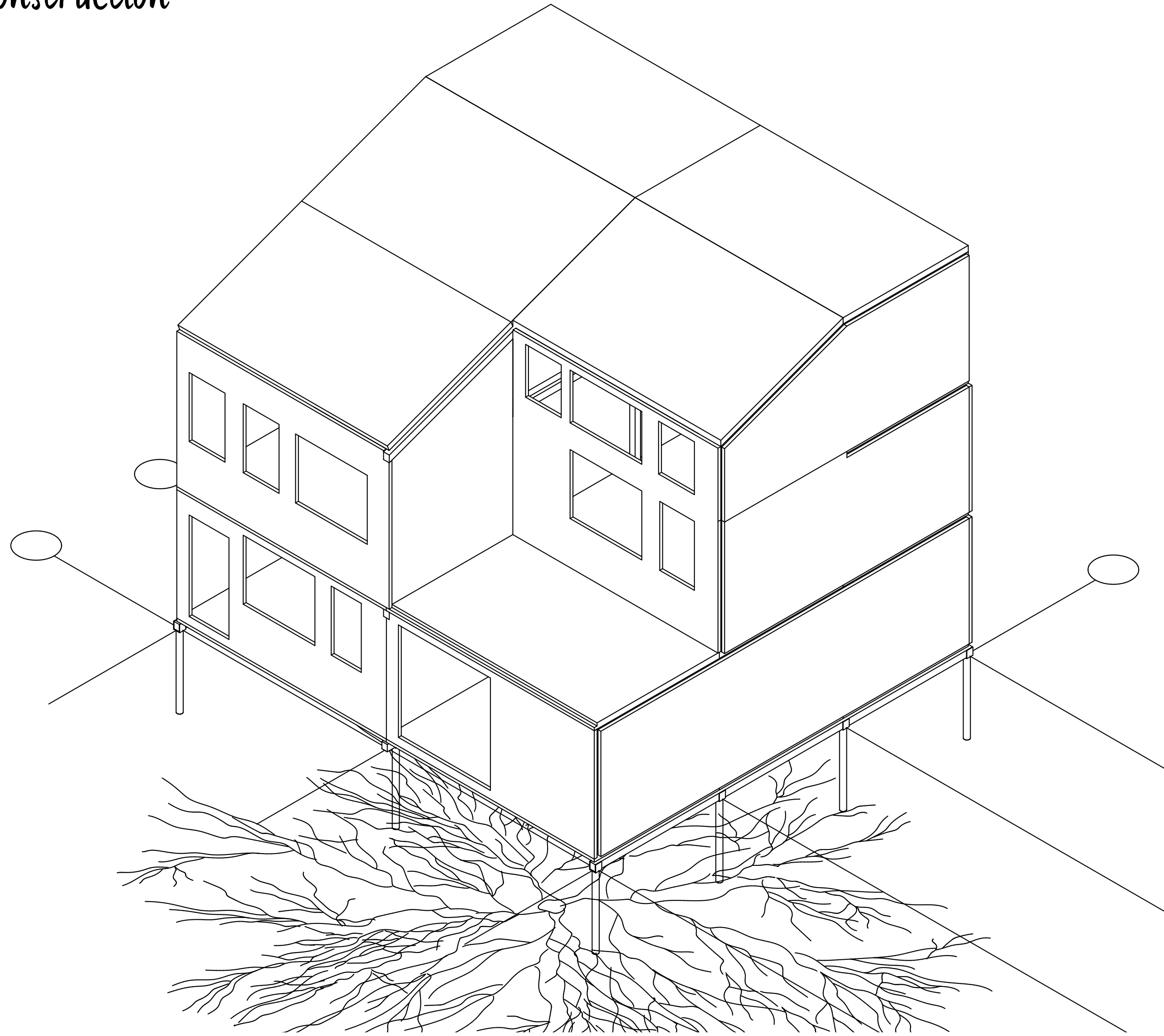

Look, the building actually kind of 'floats' above the ground!

the soil is disturbed as minimal as possible...!



sound



light



colour

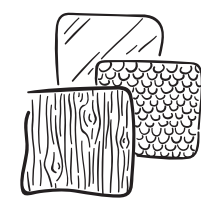

texture



smell



privacy



interaction

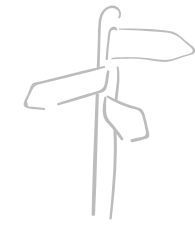

wayfinding

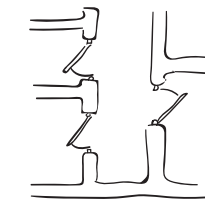

layout



personalisation



nature



comfort



routine



confidence

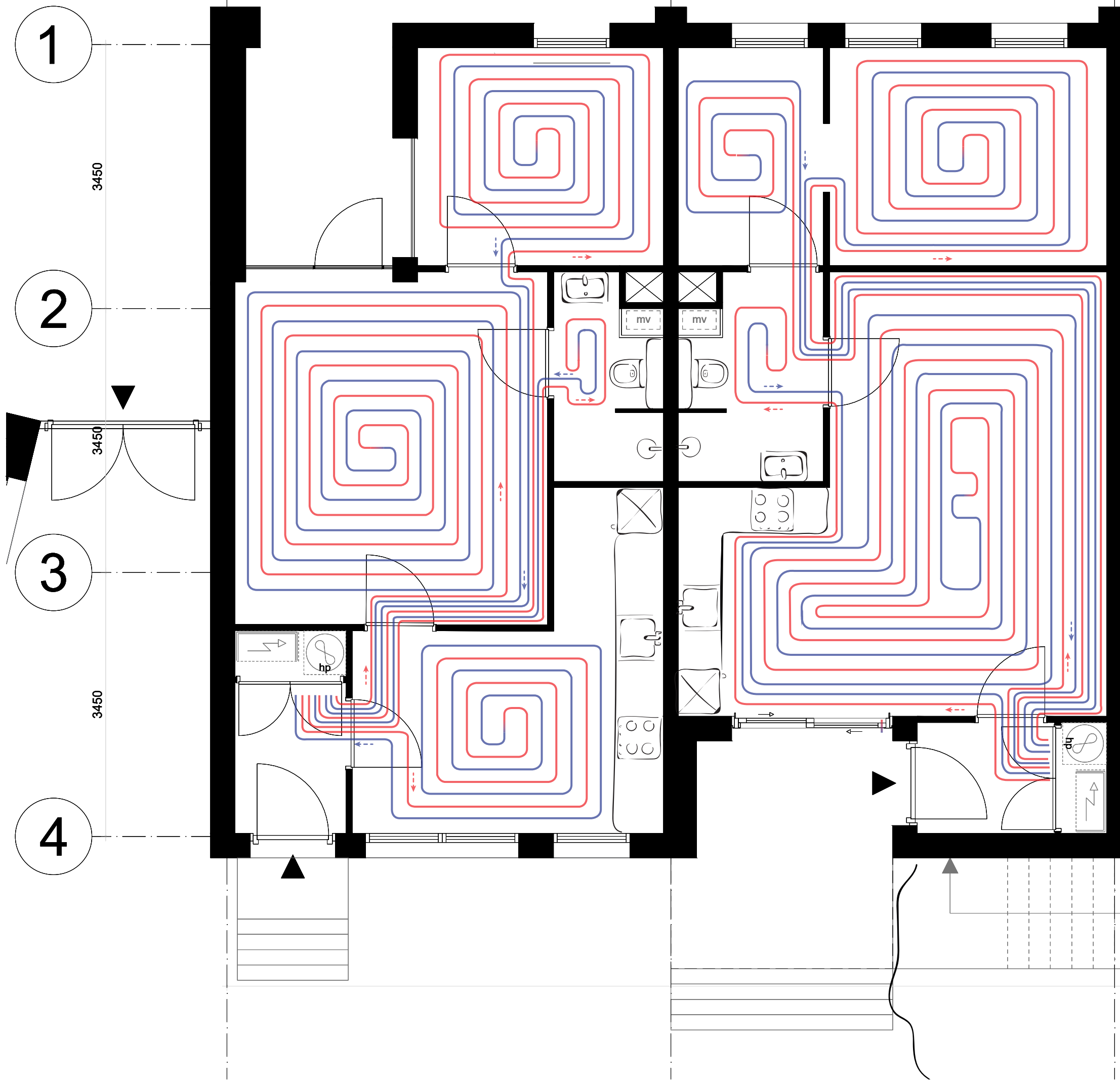





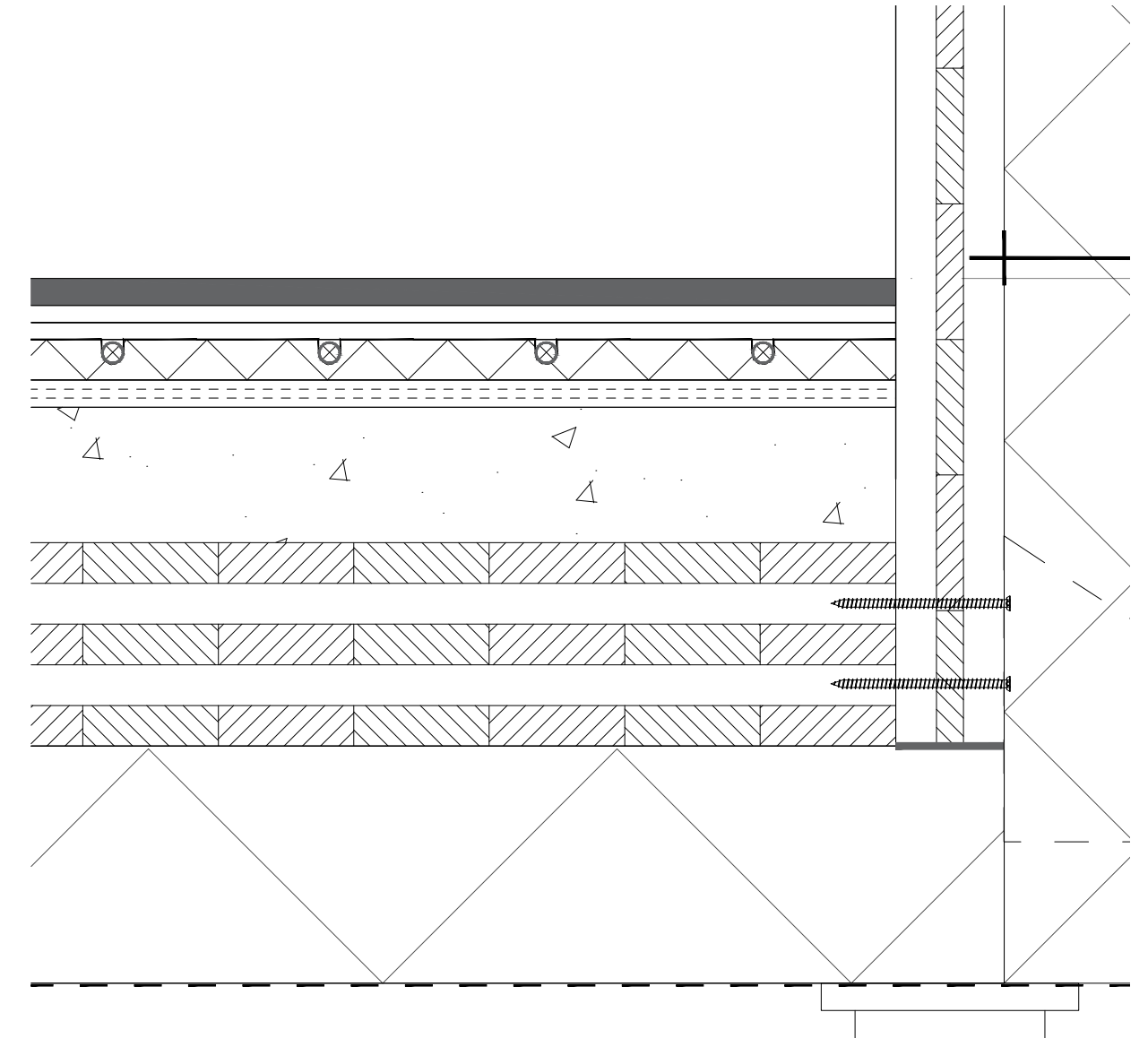
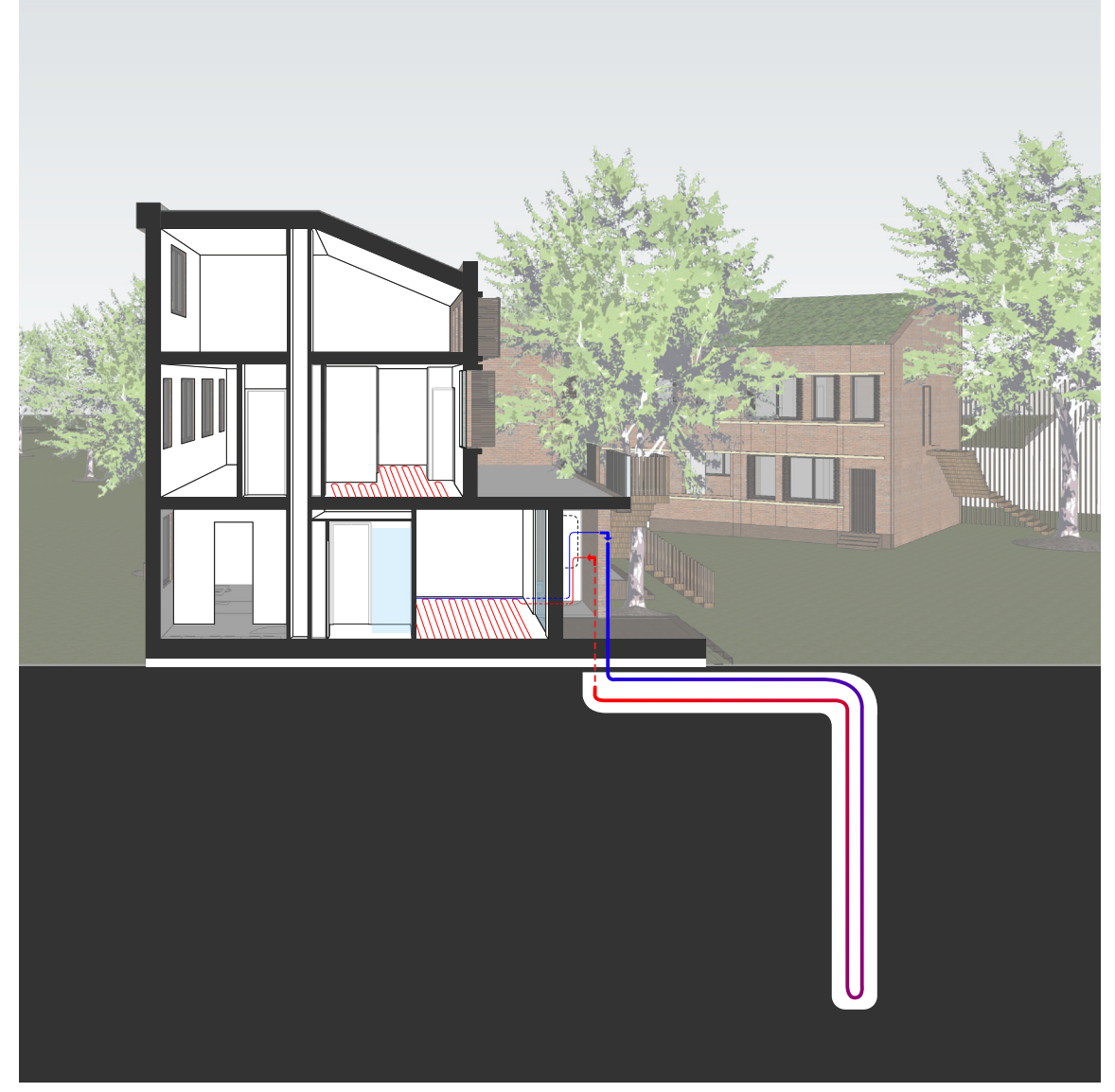





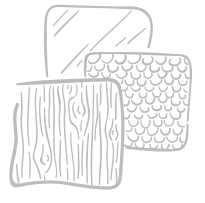

low-temperature underfloor heating is applied...

in combination with a heat-pump and a vertical collector

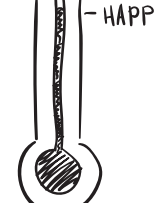

the snailhouse configuration provides an even distribution of heating and cooling

-  sound
-  light
-  colour
-  texture
-  smell
-  privacy
-  interaction
-  wayfinding
-  layout
-  personalisation
-  nature
-  comfort
-  routine
-  confidence



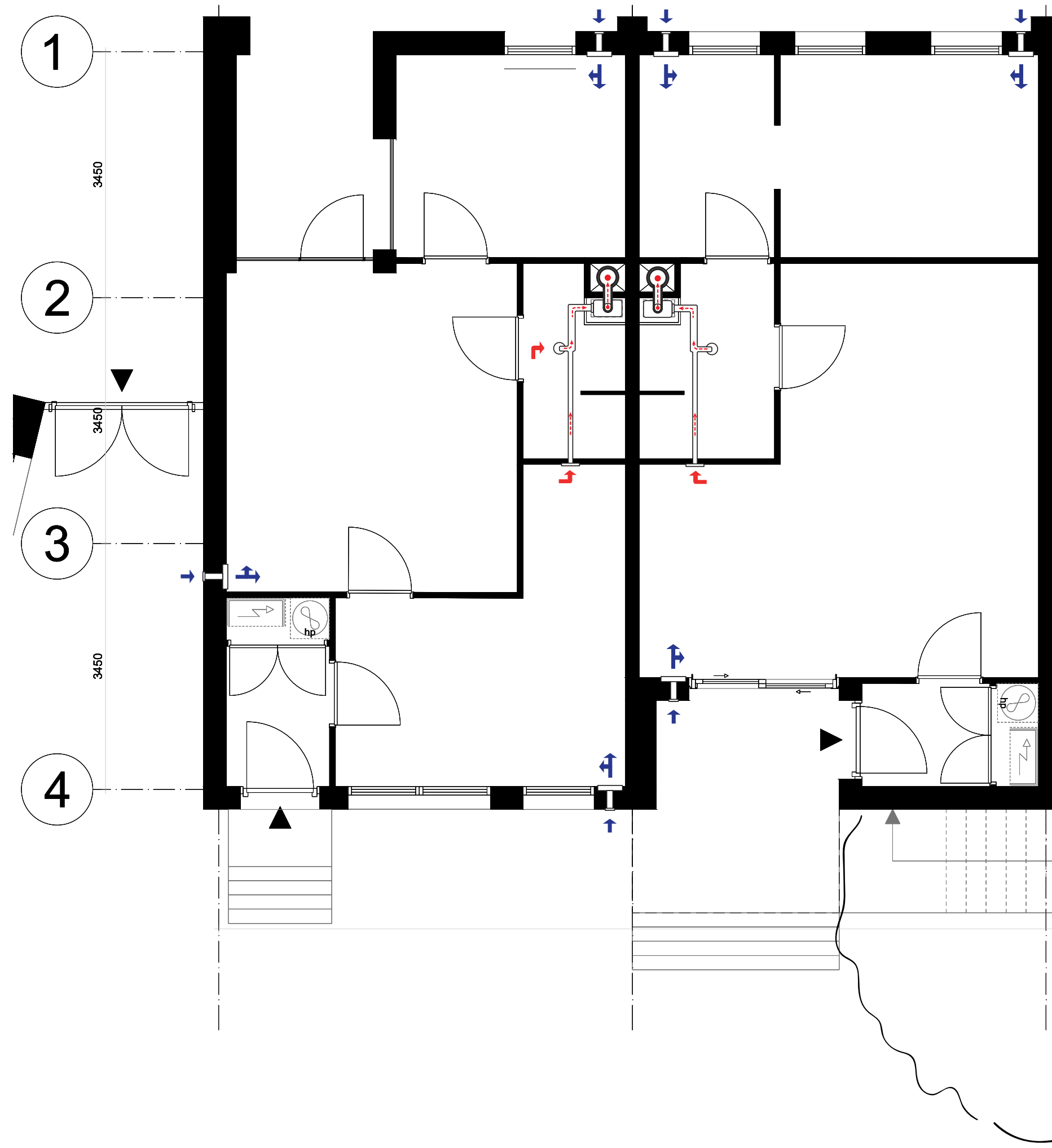

fresh-r systems are applied in every room...

these provide fresh air while also warming it up a bit to prevent heat-loss



Mechanical ventilation is applied in the wet areas and near the kitchen for the output.

and we don't have problems with incoming noise like when there would be a vent.



sound



light



colour

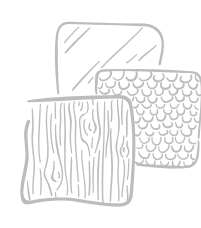

texture



smell



privacy



interaction

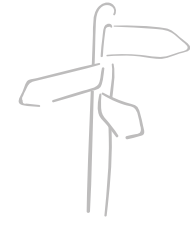

wayfinding

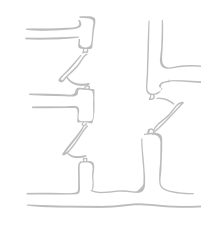

layout

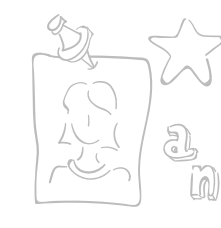

personalisation



nature



comfort



routine



confidence



rainwater is collected and used for irrigation of the courtyard

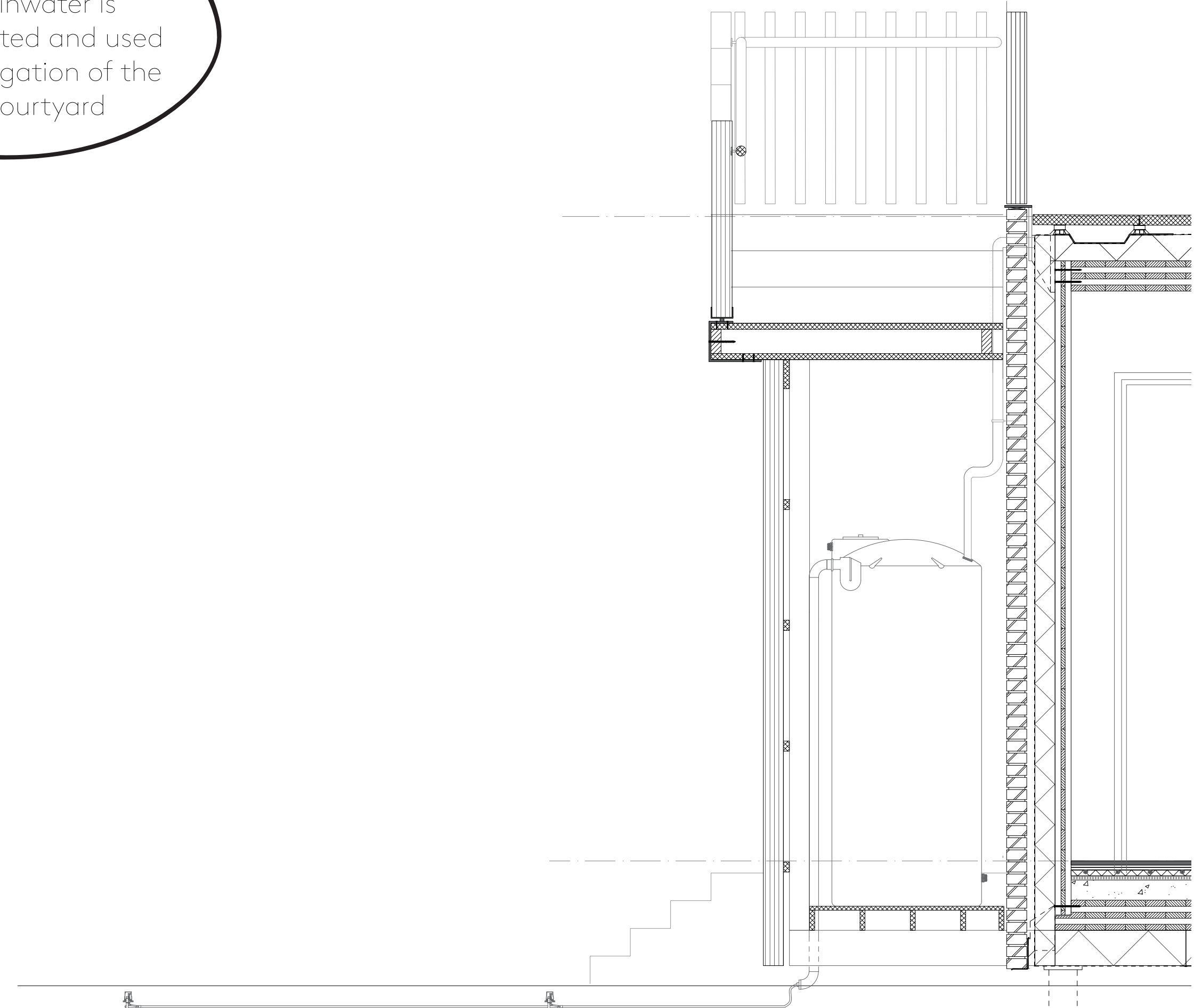

sound



light



colour

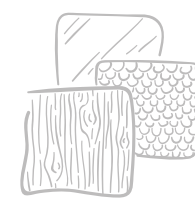

texture



smell



privacy



interaction

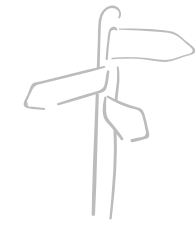

wayfinding



layout



personalisation



nature



comfort



routine



confidence

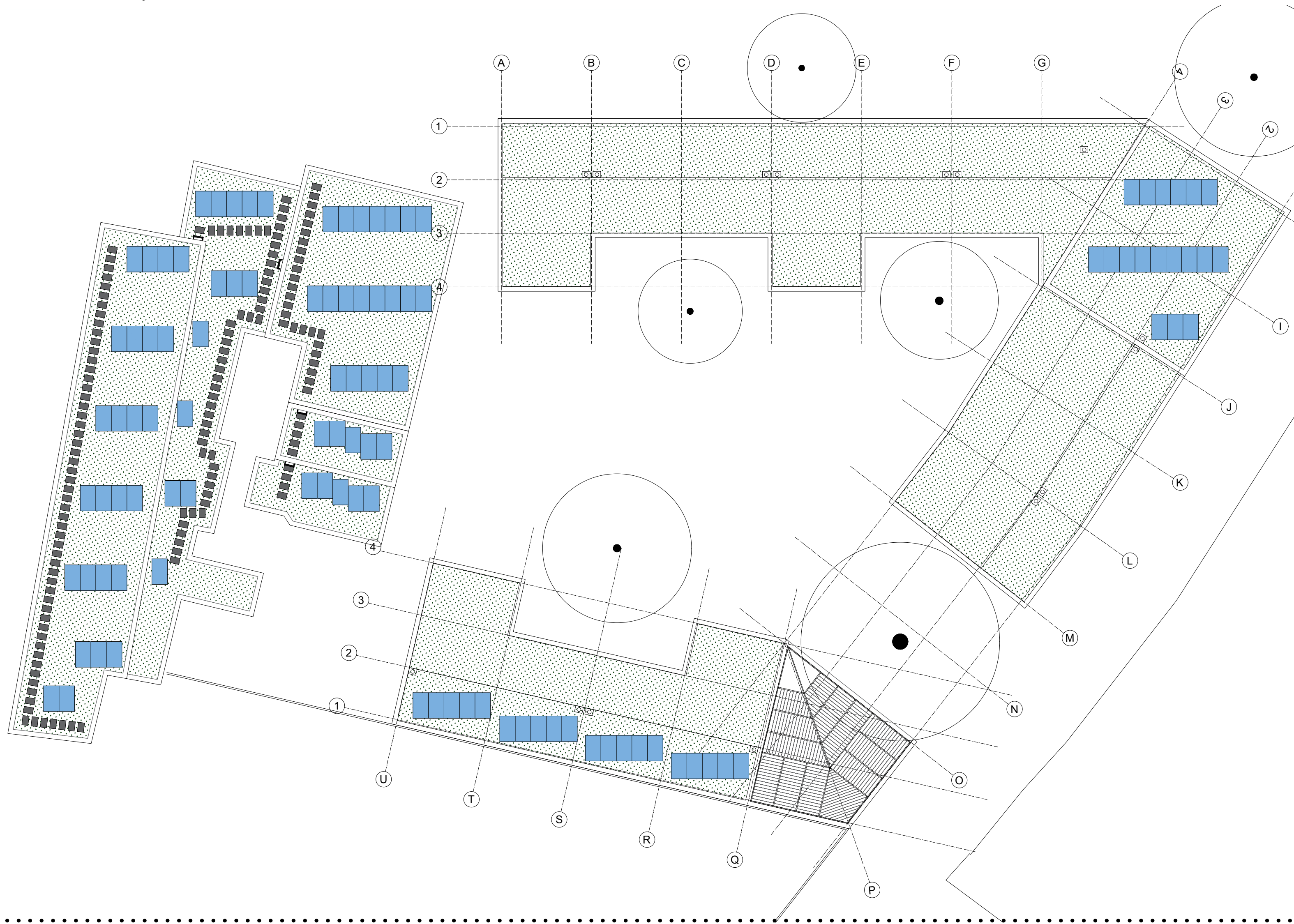

sound



light



colour

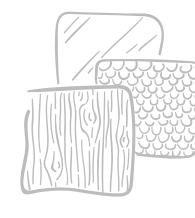

texture



smell



privacy



interaction

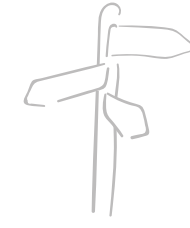

wayfinding



layout



personalisation



nature



comfort



routine



confidence

And now it's time  
to talk about the  
interior!



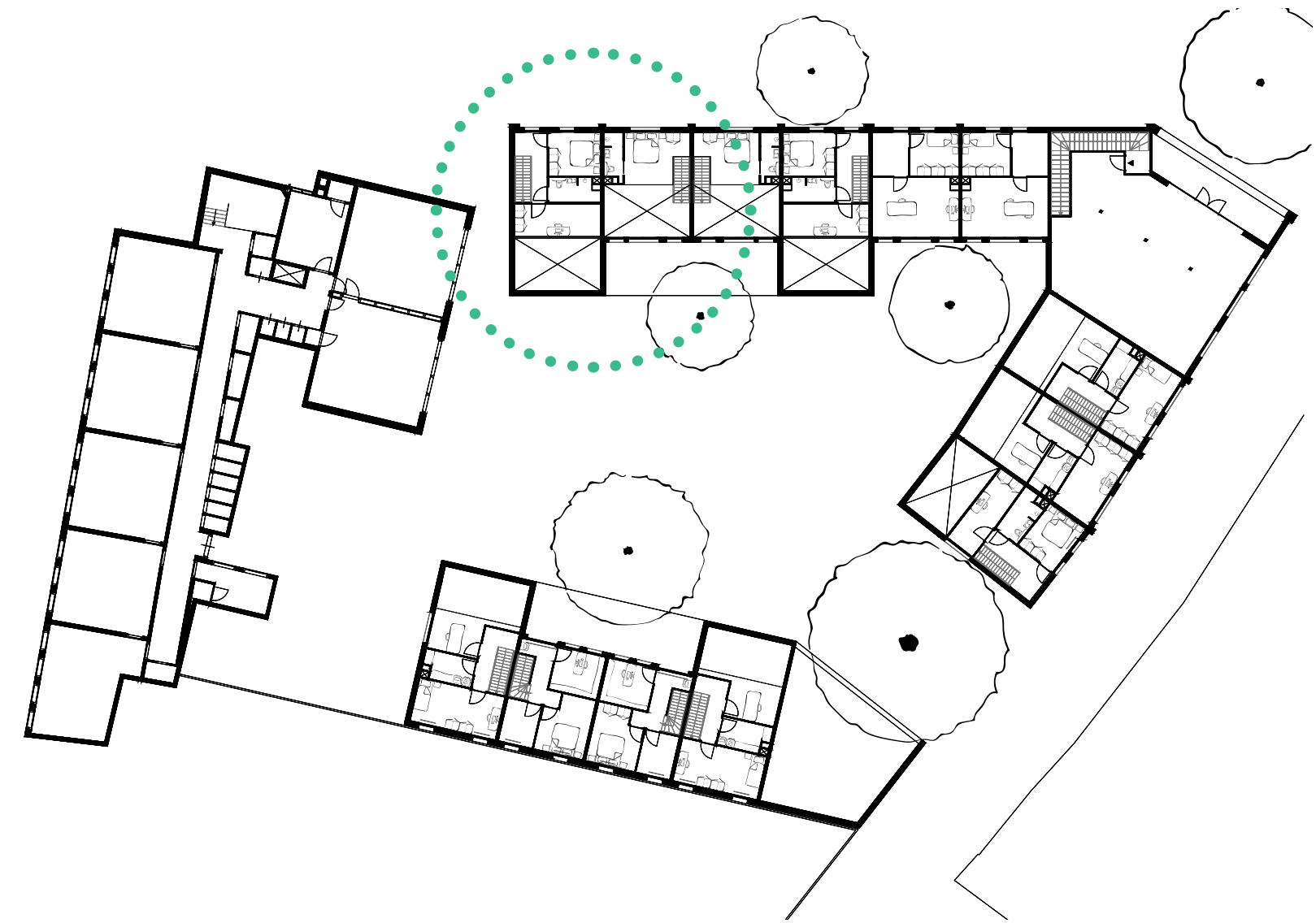
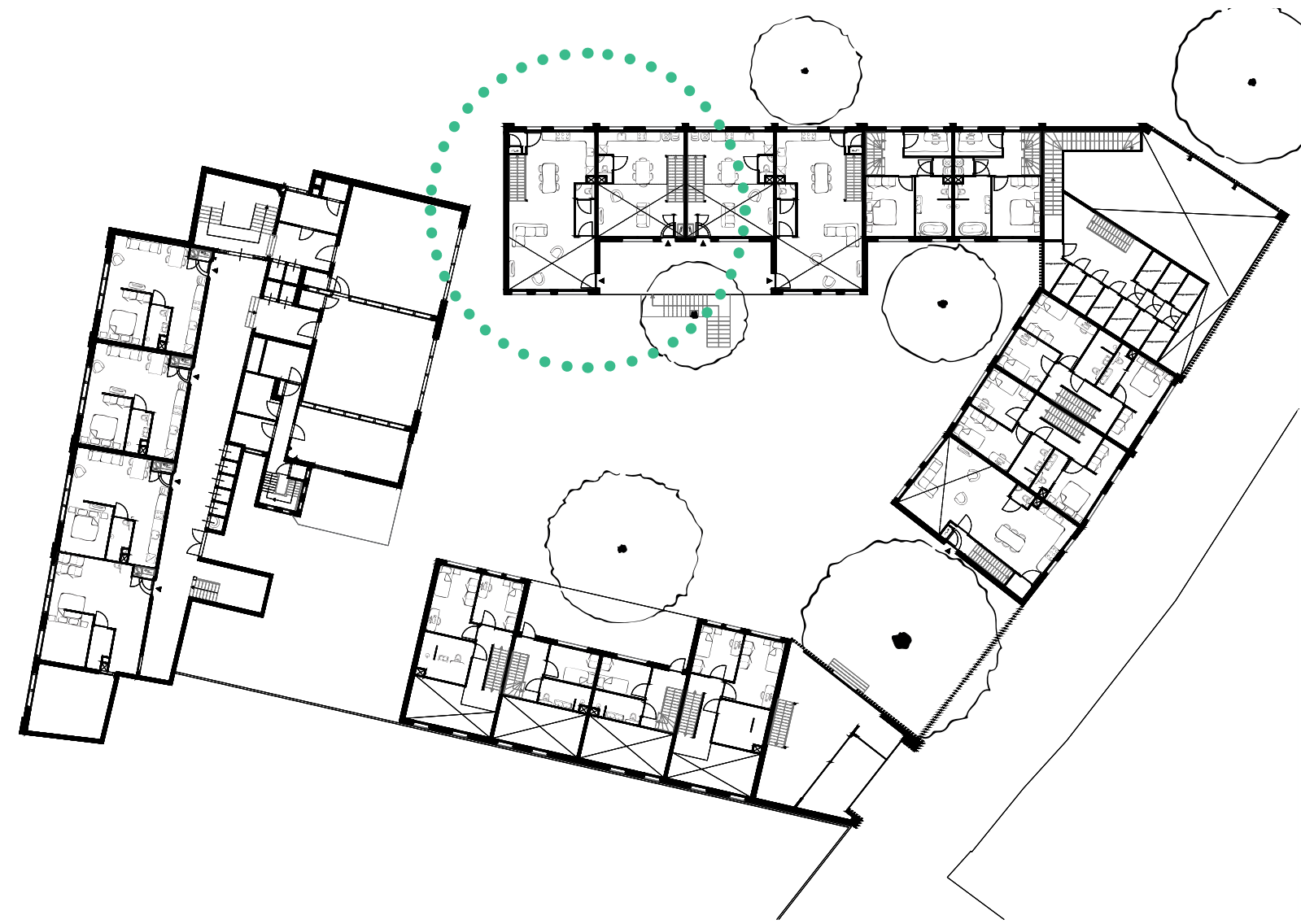
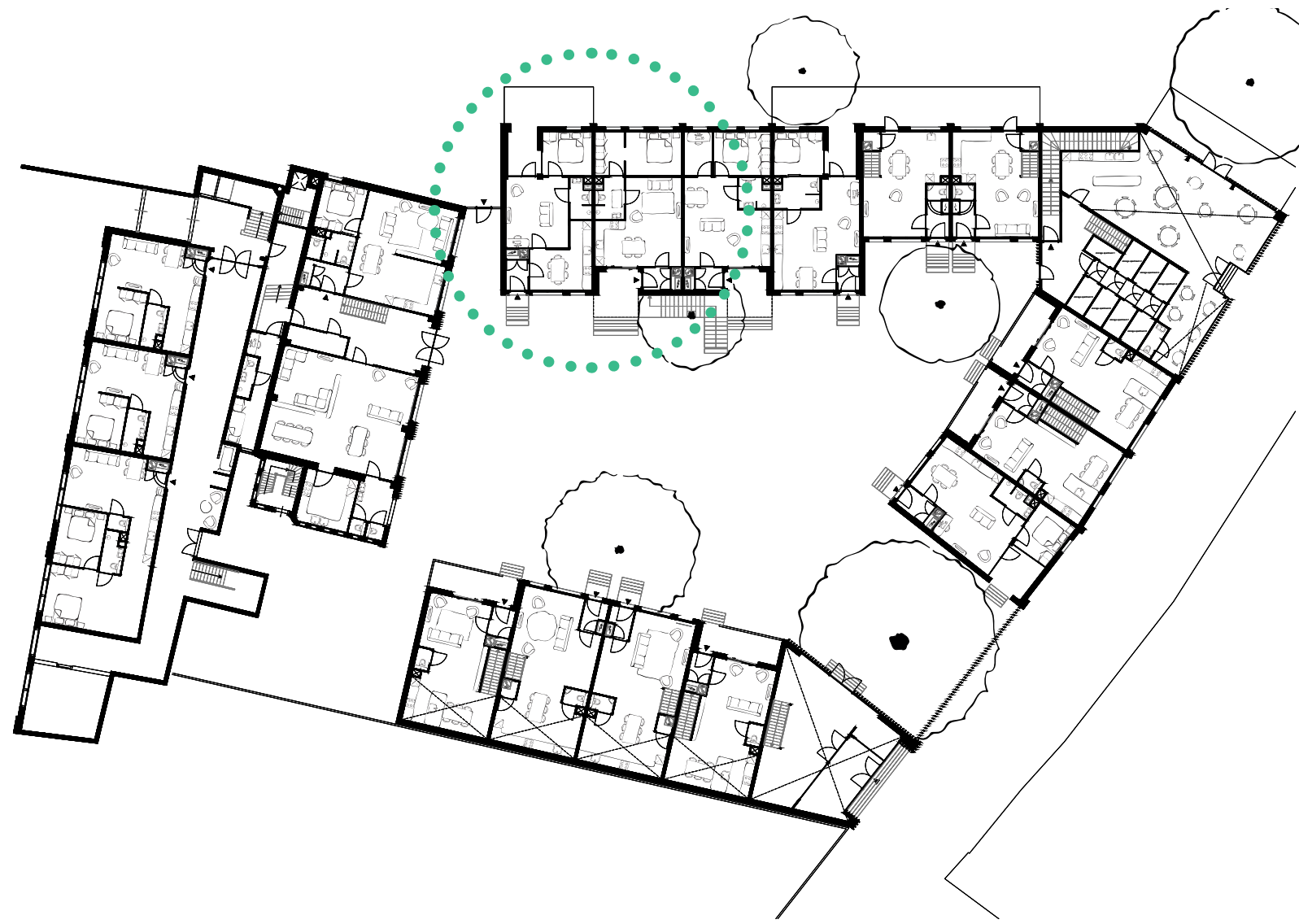

Lucas



I dislike clutter, so I want every room to be seperated.

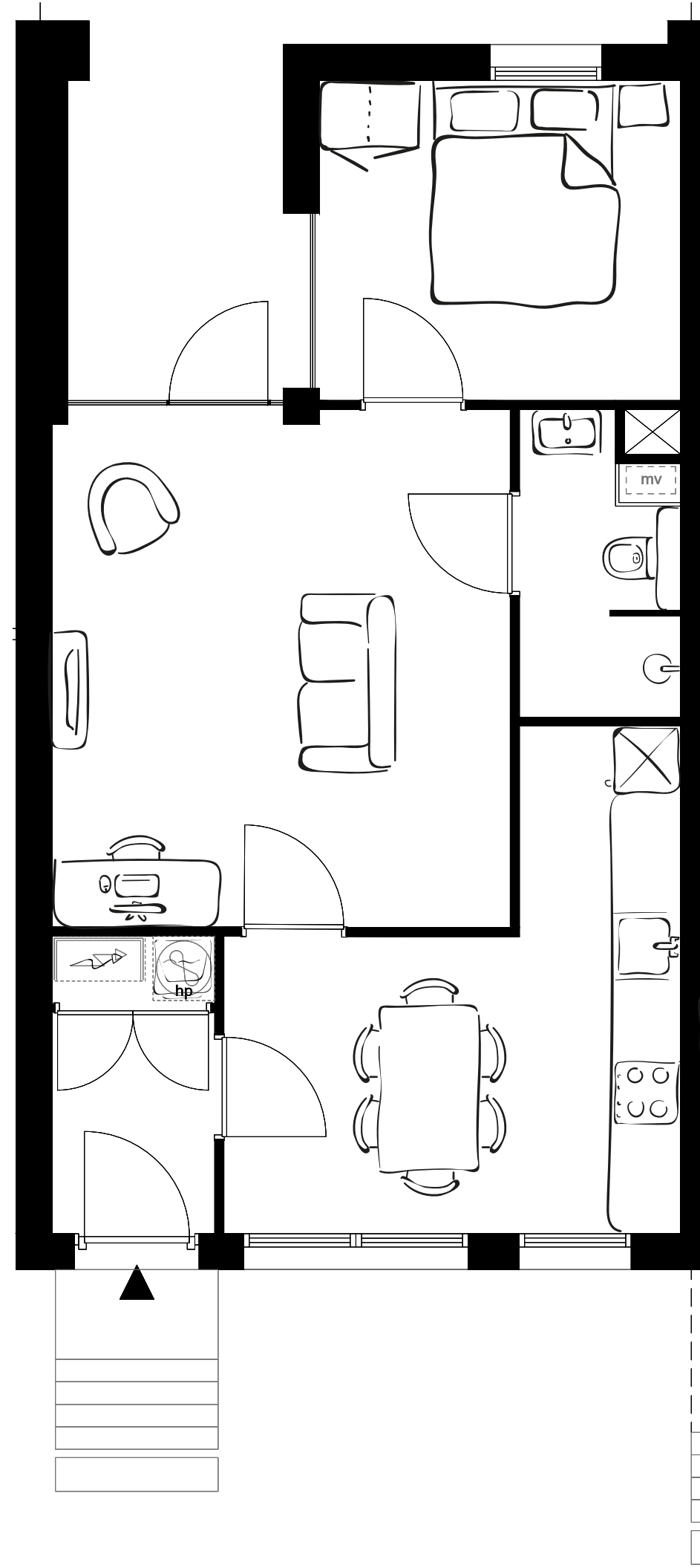

sound



light



colour

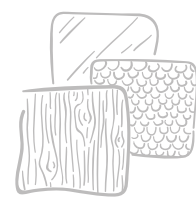

texture



smell



privacy



interaction

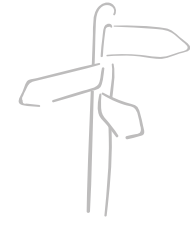

wayfinding

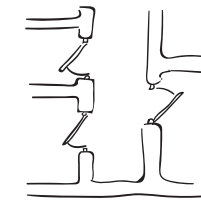

layout

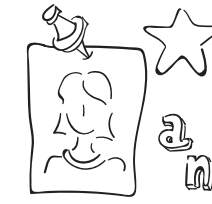

personalisation



nature



comfort

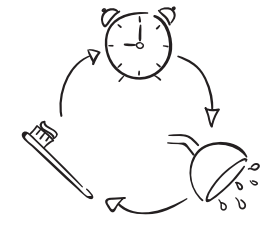

routine



confidence

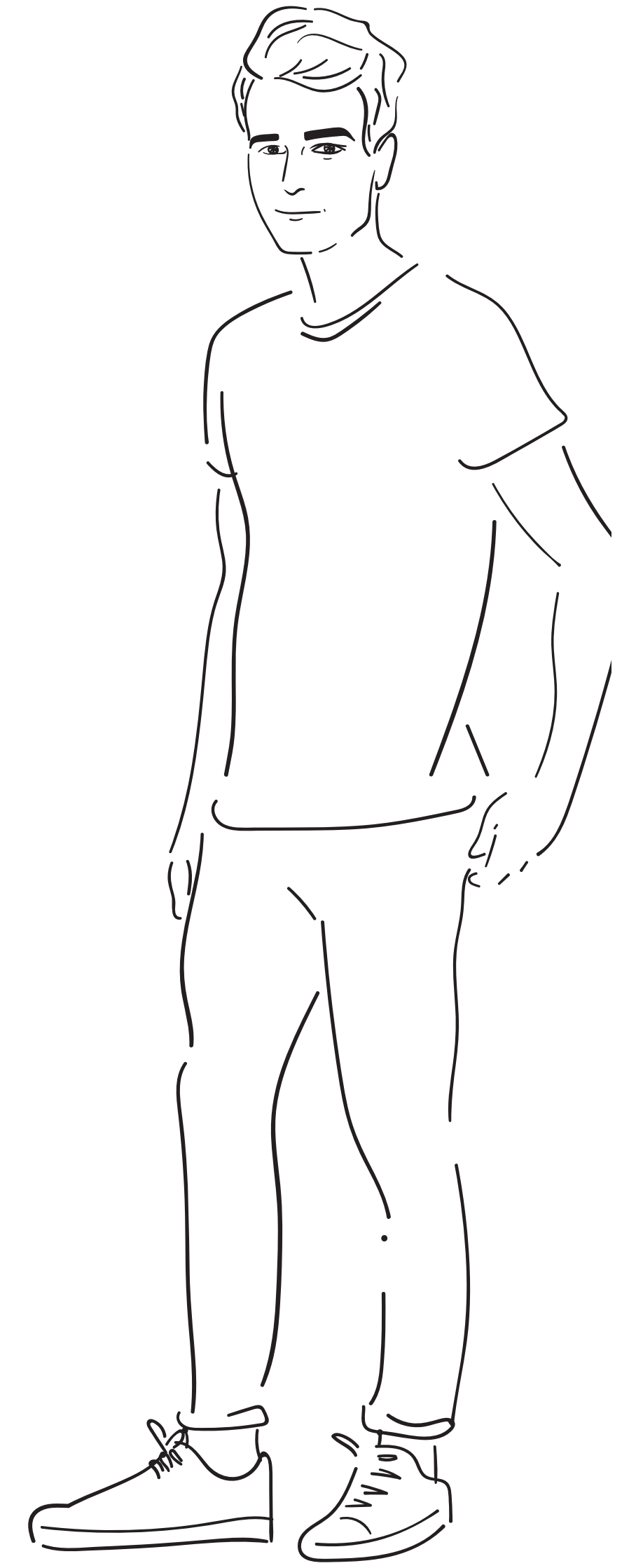

sound



light

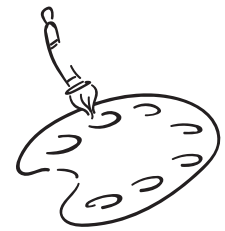

colour

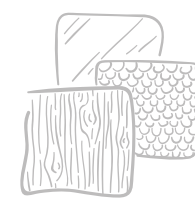

texture



smell



privacy



interaction

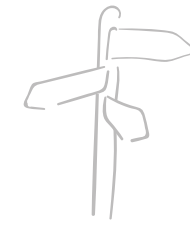

wayfinding

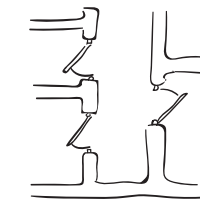

layout



personalisation



nature



comfort

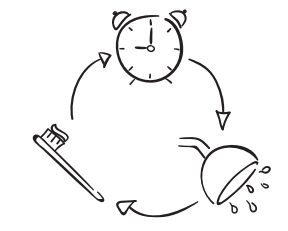

routine

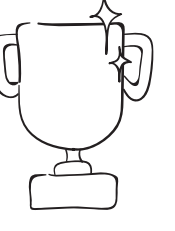

confidence



sound



light

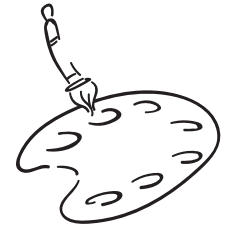

colour

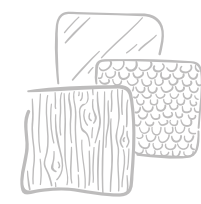

texture



smell



privacy



interaction

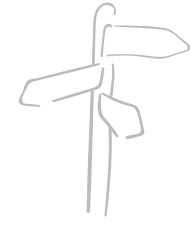

wayfinding

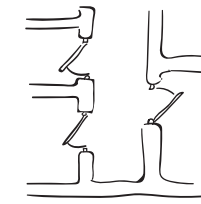

layout

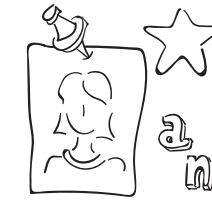

personalisation



nature



comfort

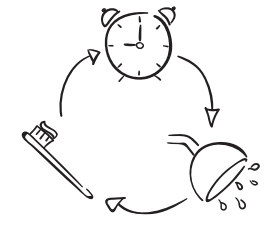

routine



confidence





sound



light

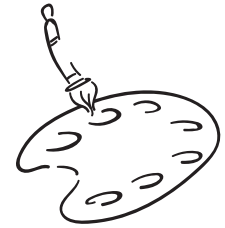

colour

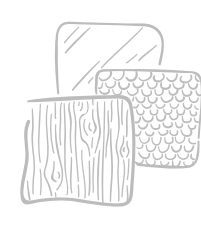

texture



smell



privacy



interaction

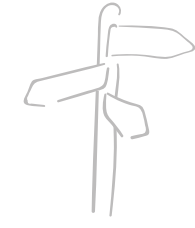

wayfinding

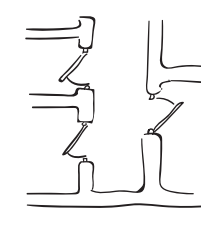

layout



personalisation



nature



comfort

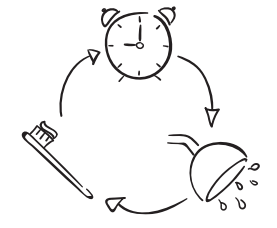

routine

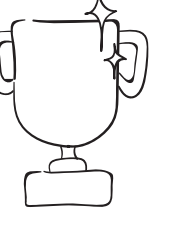

confidence

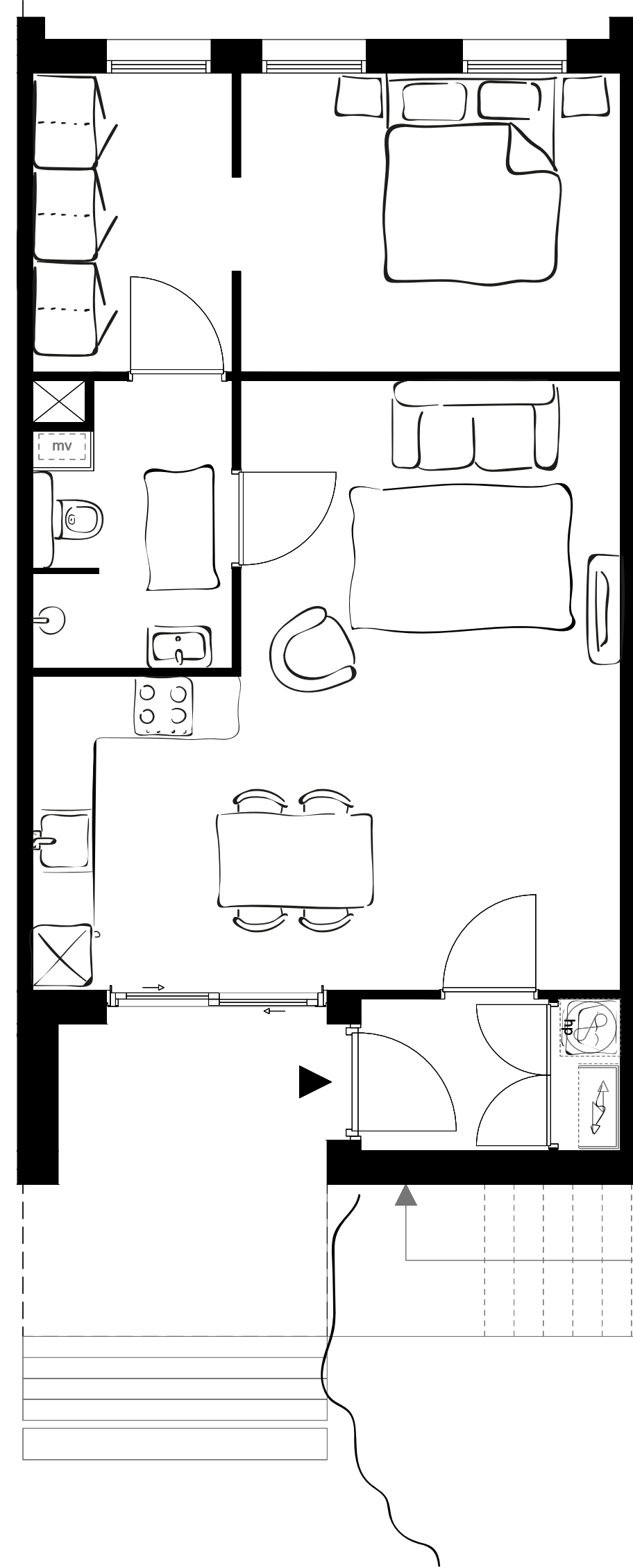

Julia

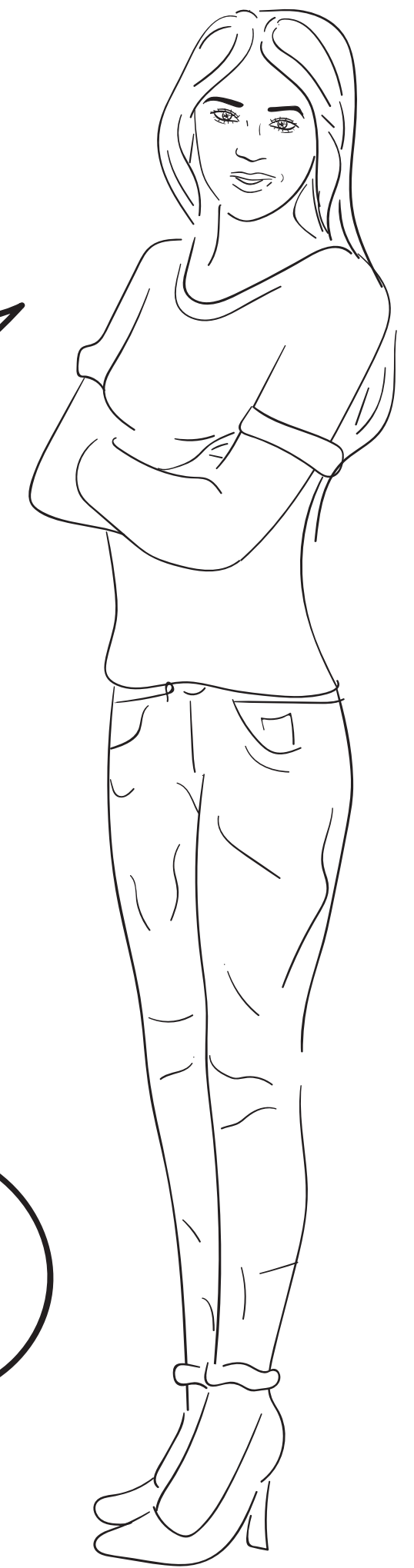

I find it difficult to follow routine, so I need a bit help with that!

I need to go through the bathroom to get to the bedroom...

... so that reminds me of showering and brushing my teeth!



sound



light



colour

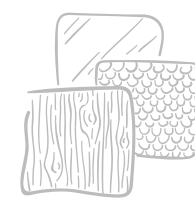

texture



smell



privacy



interaction

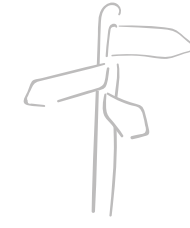

wayfinding

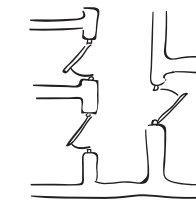

layout



personalisation



nature

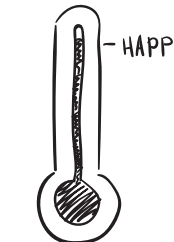

comfort

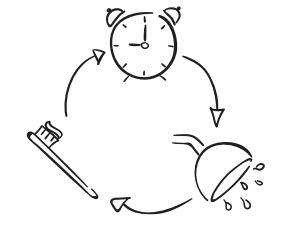

routine



confidence



I also like to walk around barefoot, so I can feel all the different textures



sound



light

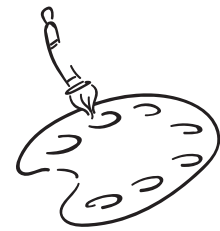

colour

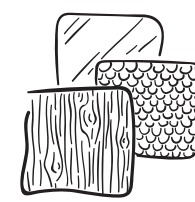

texture



smell



privacy



interaction

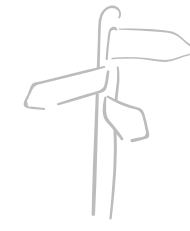

wayfinding

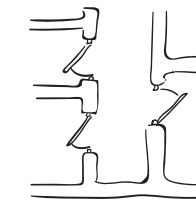

layout



personalisation



nature

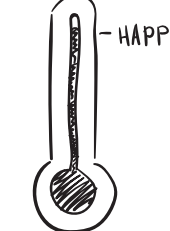

comfort

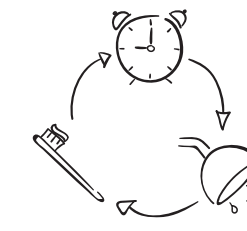

routine

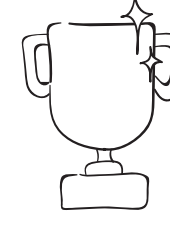

confidence



sound



light

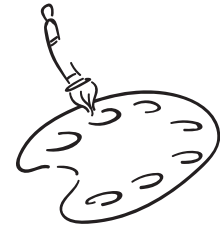

colour

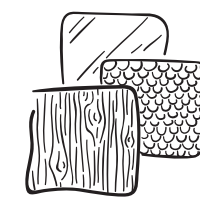

texture



smell



privacy



interaction

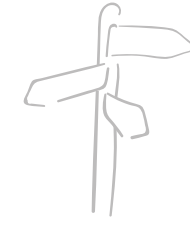

wayfinding

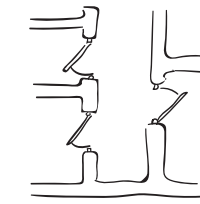

layout



personalisation



nature



comfort

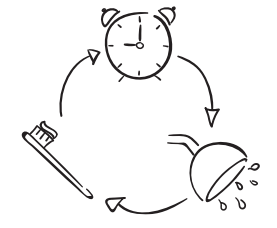

routine



confidence



sound



light

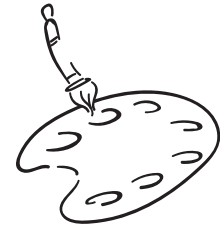

colour

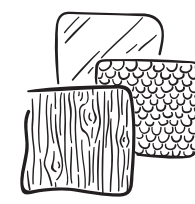

texture



smell



privacy



interaction

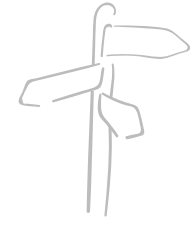

wayfinding

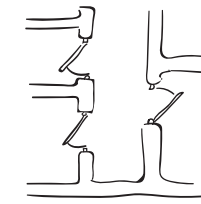

layout

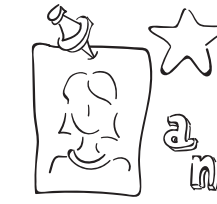

personalisation



nature



comfort

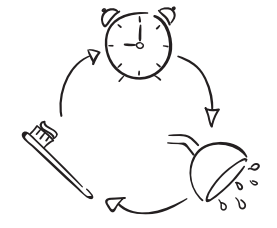

routine



confidence

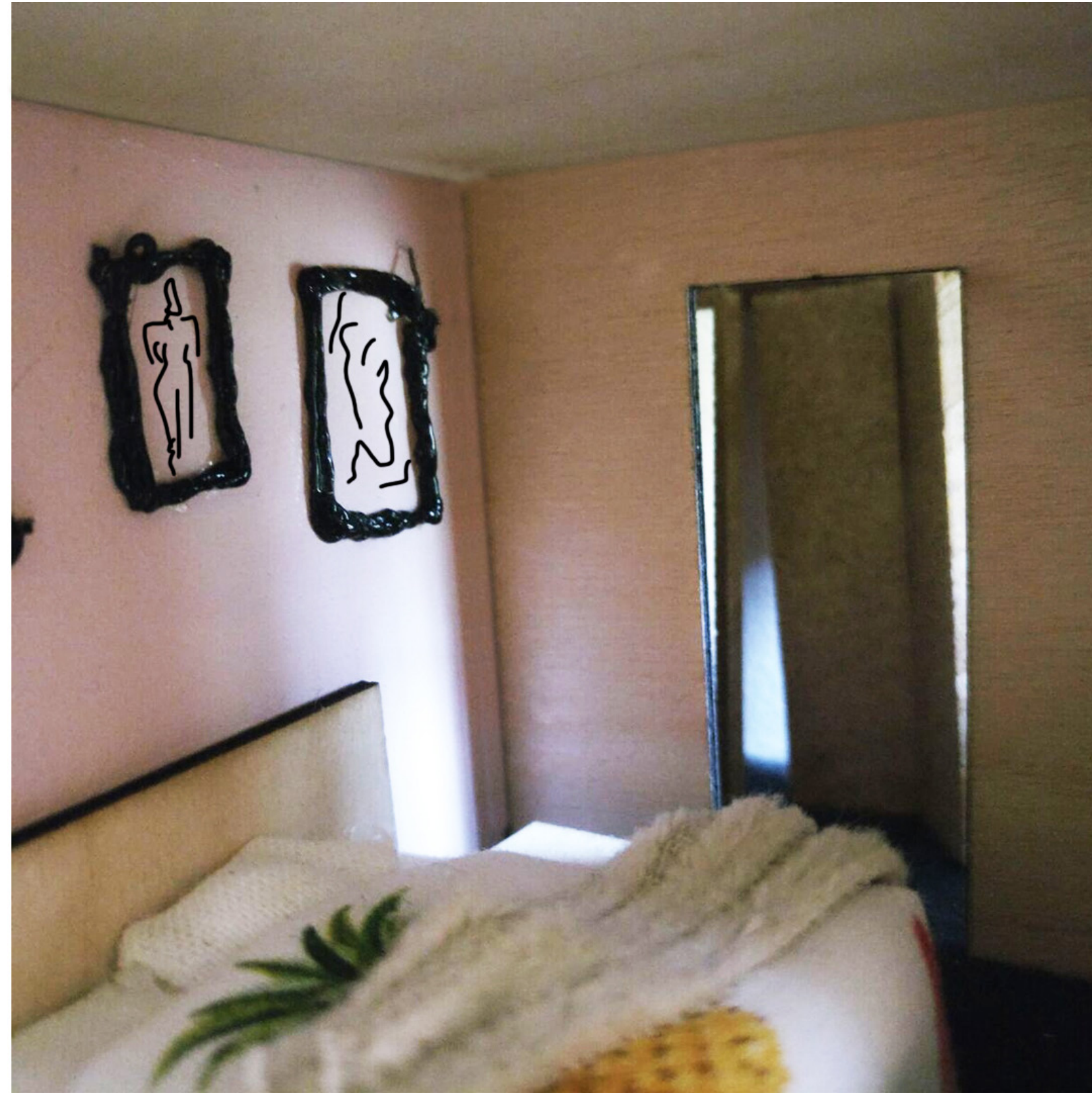

sound



light

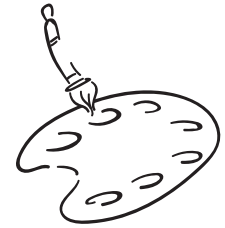

colour

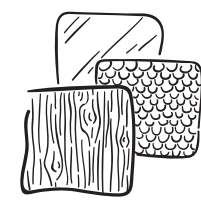

texture



smell



privacy



interaction

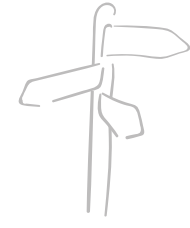

wayfinding

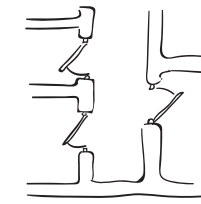

layout



personalisation



nature



comfort

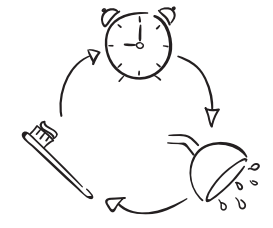

routine



confidence

interior design  
Nick and Lily

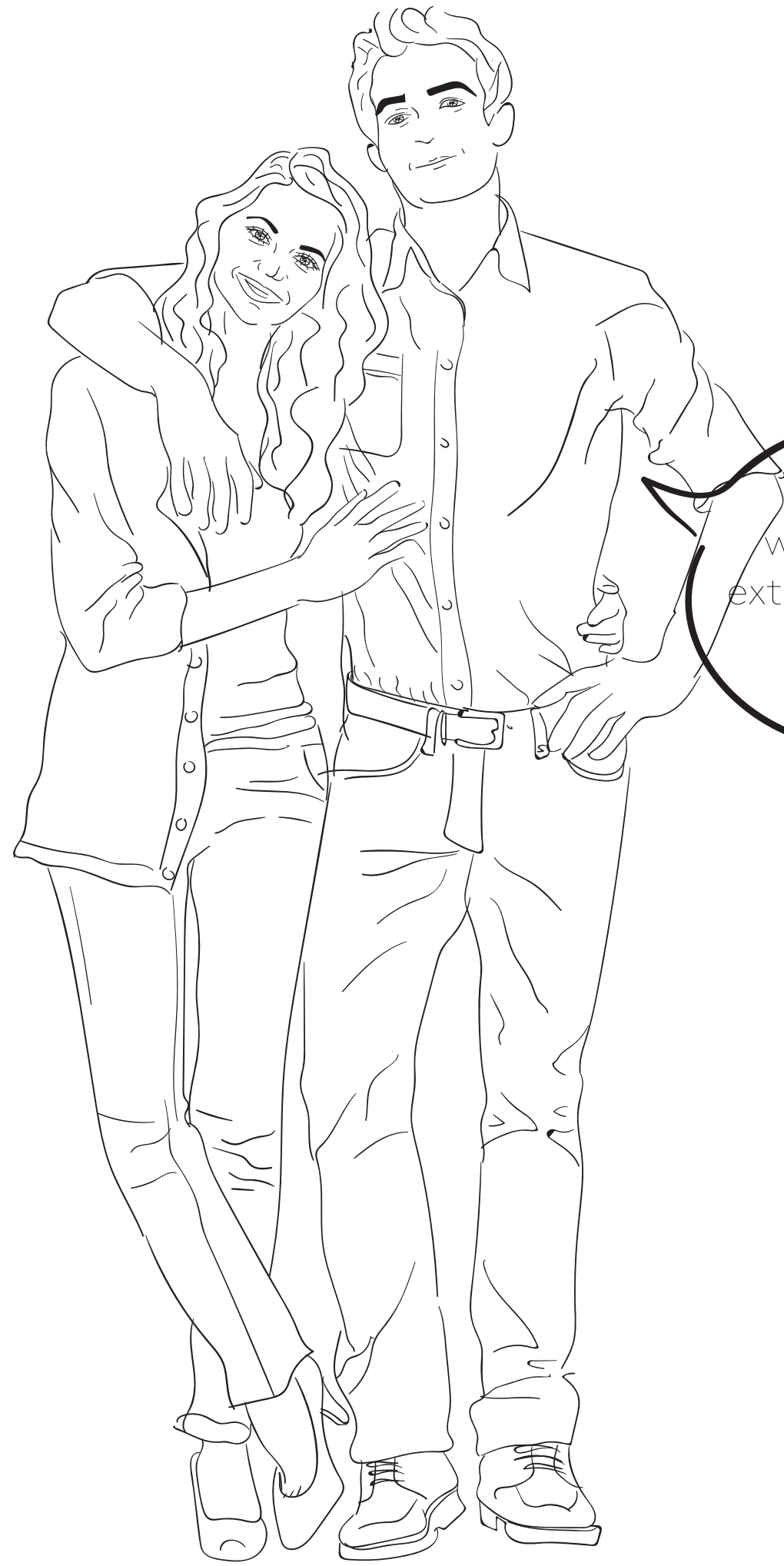

we like to have  
extra space for the  
future

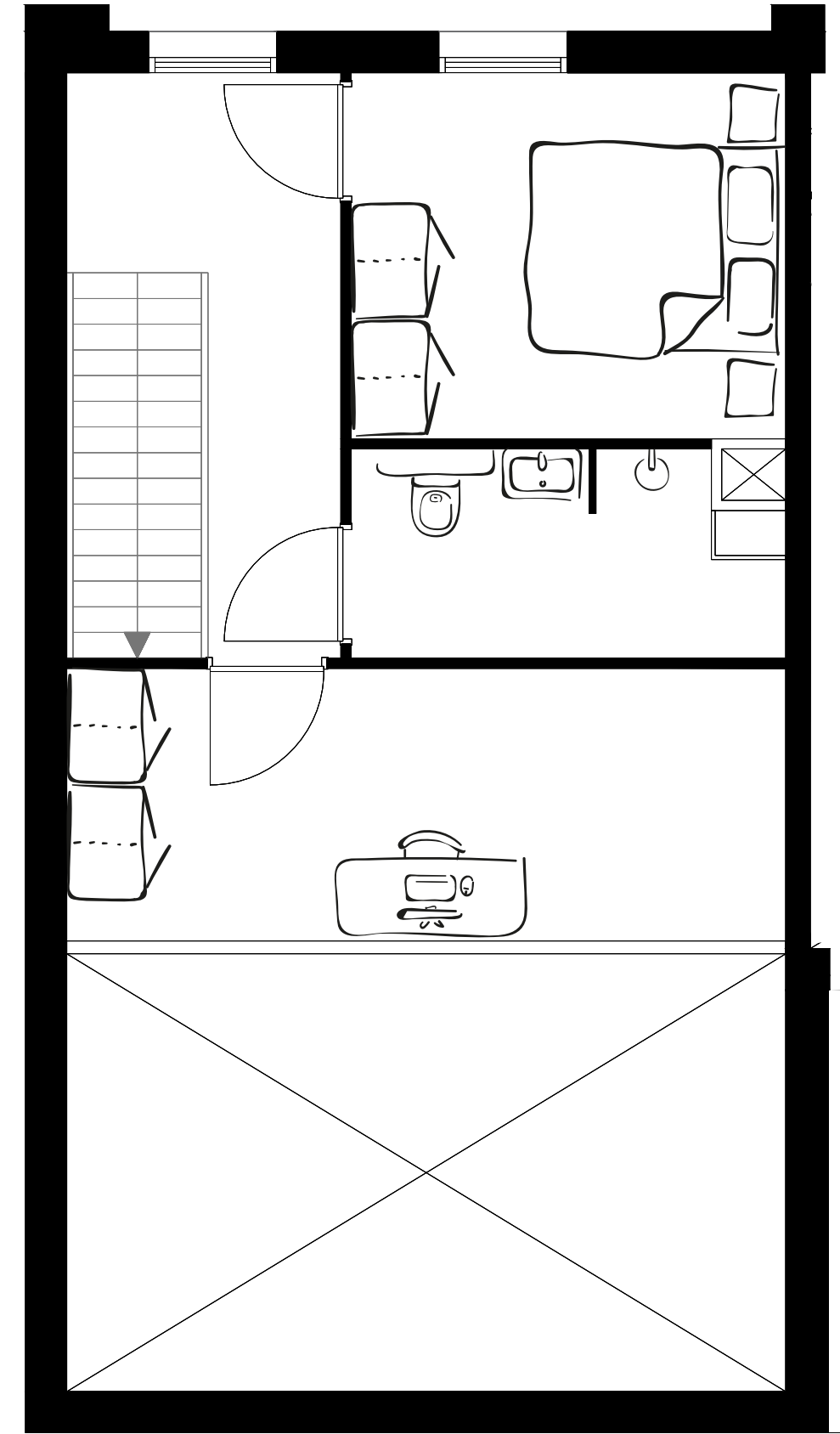
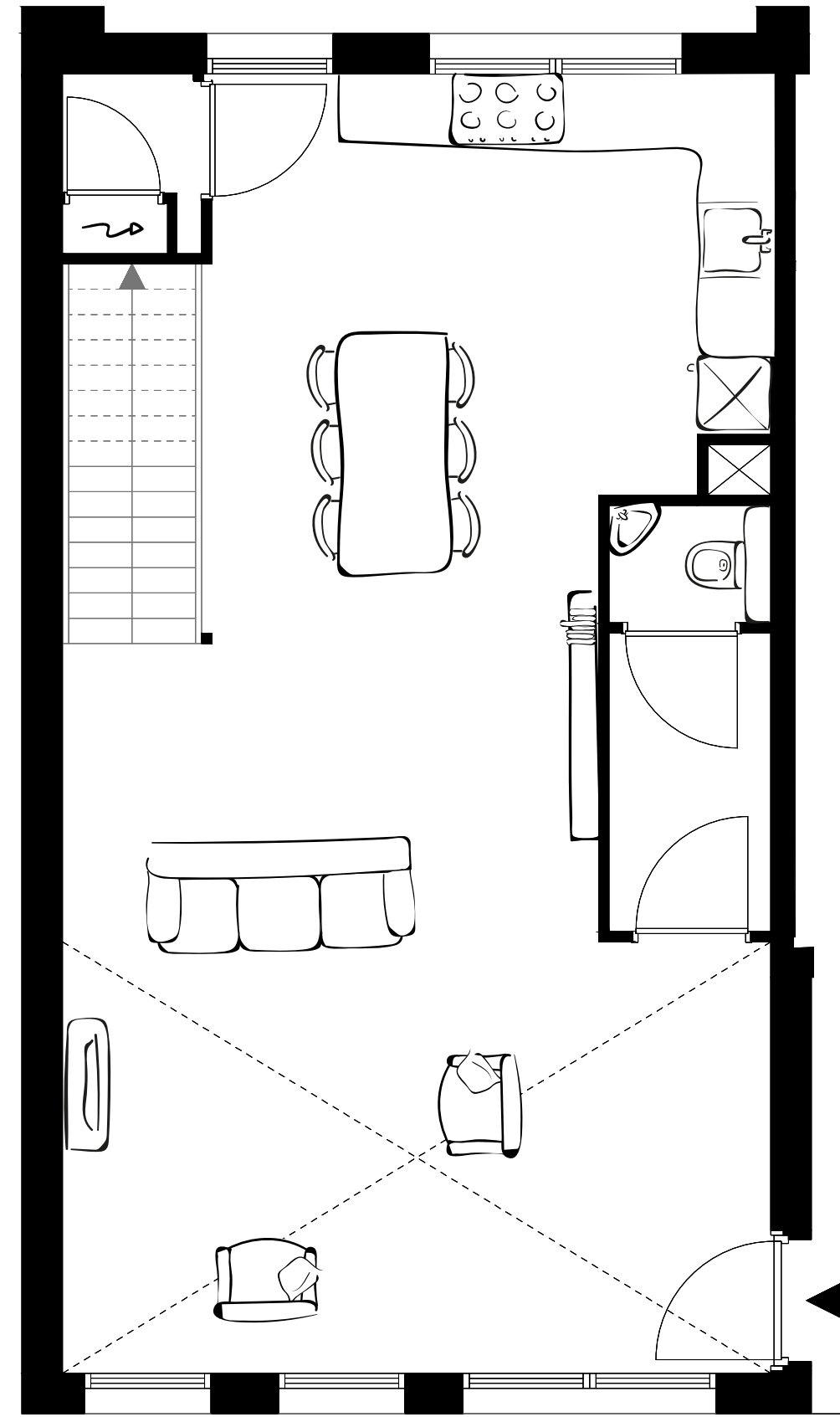

sound



light



colour

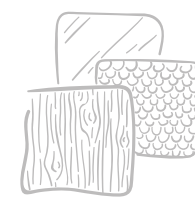

texture



smell



privacy



interaction

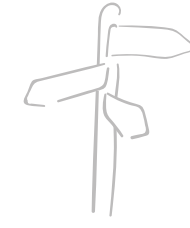

wayfinding

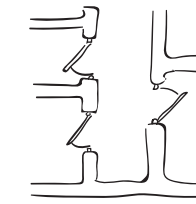

layout



personalisation



nature



comfort



routine



confidence

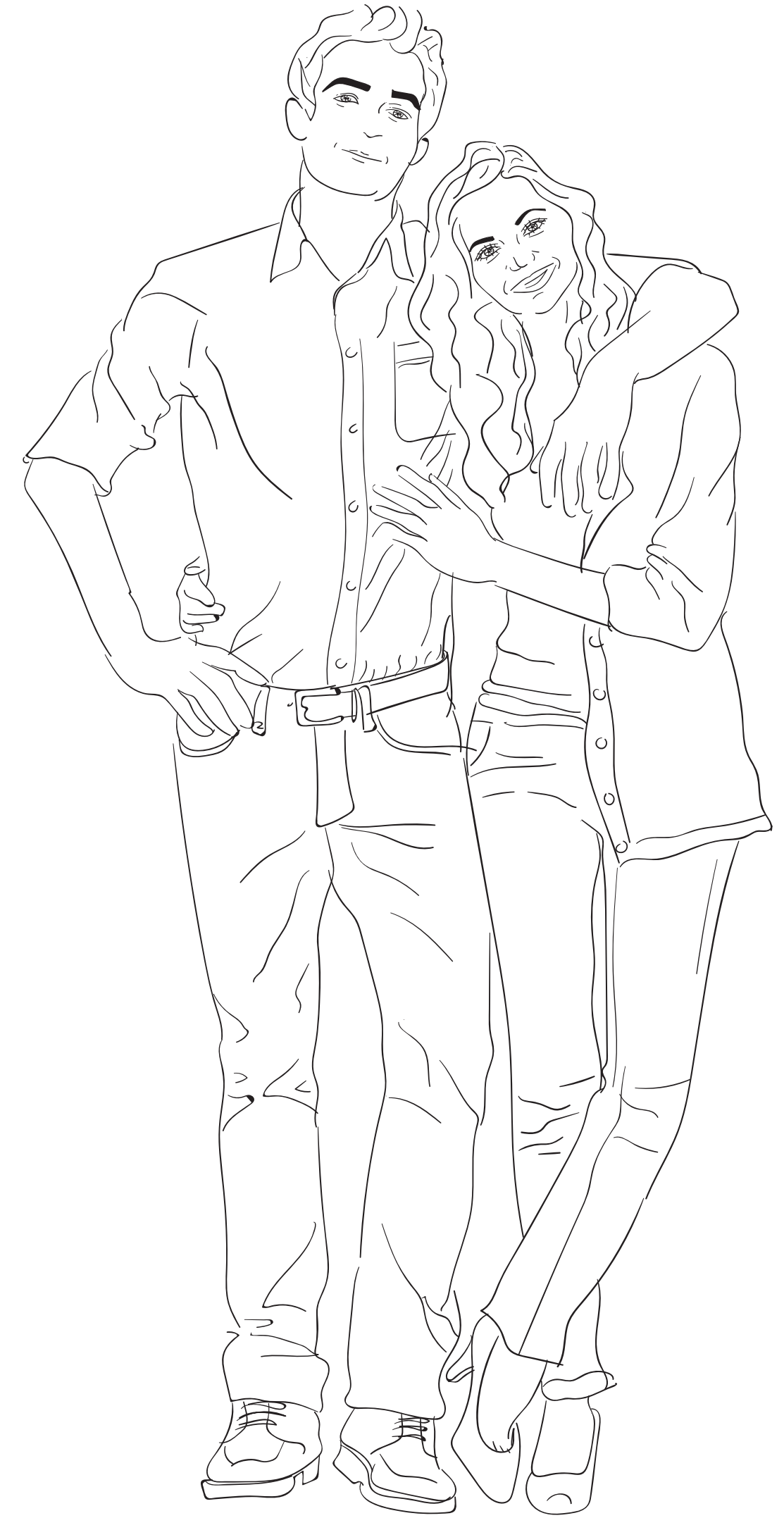
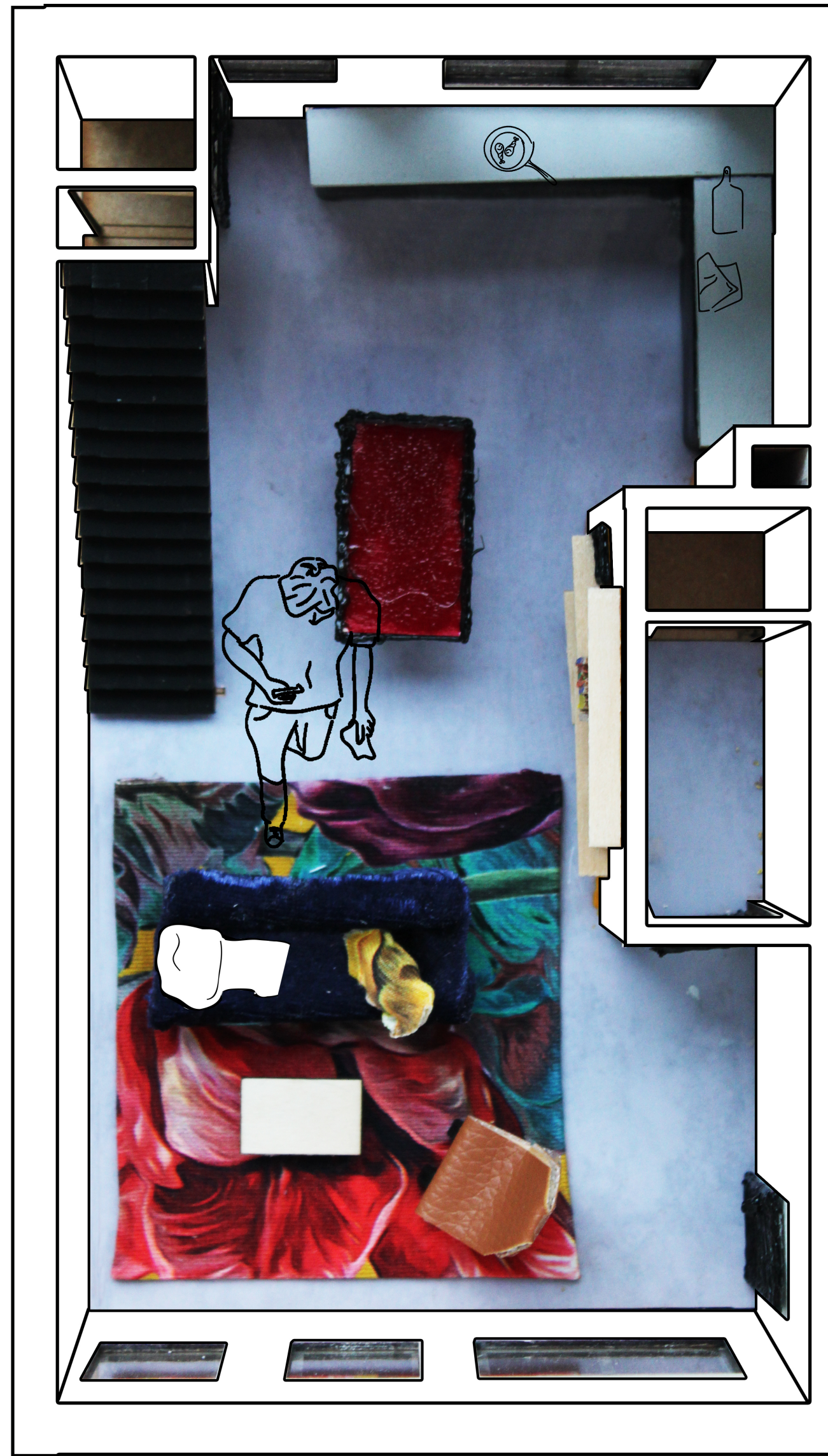

sound



light

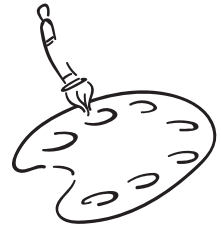

colour

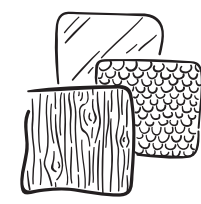

texture



smell



privacy



interaction

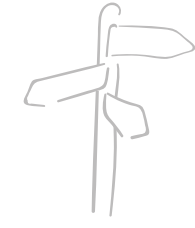

wayfinding

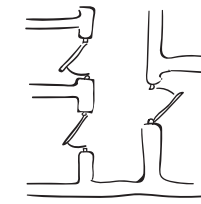

layout



personalisation



nature



comfort



routine



confidence





sound



light



colour

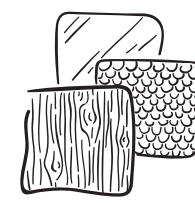

texture



smell



privacy



interaction

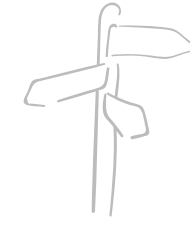

wayfinding

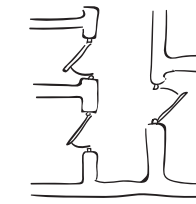

layout



personalisation



nature



comfort



routine



confidence

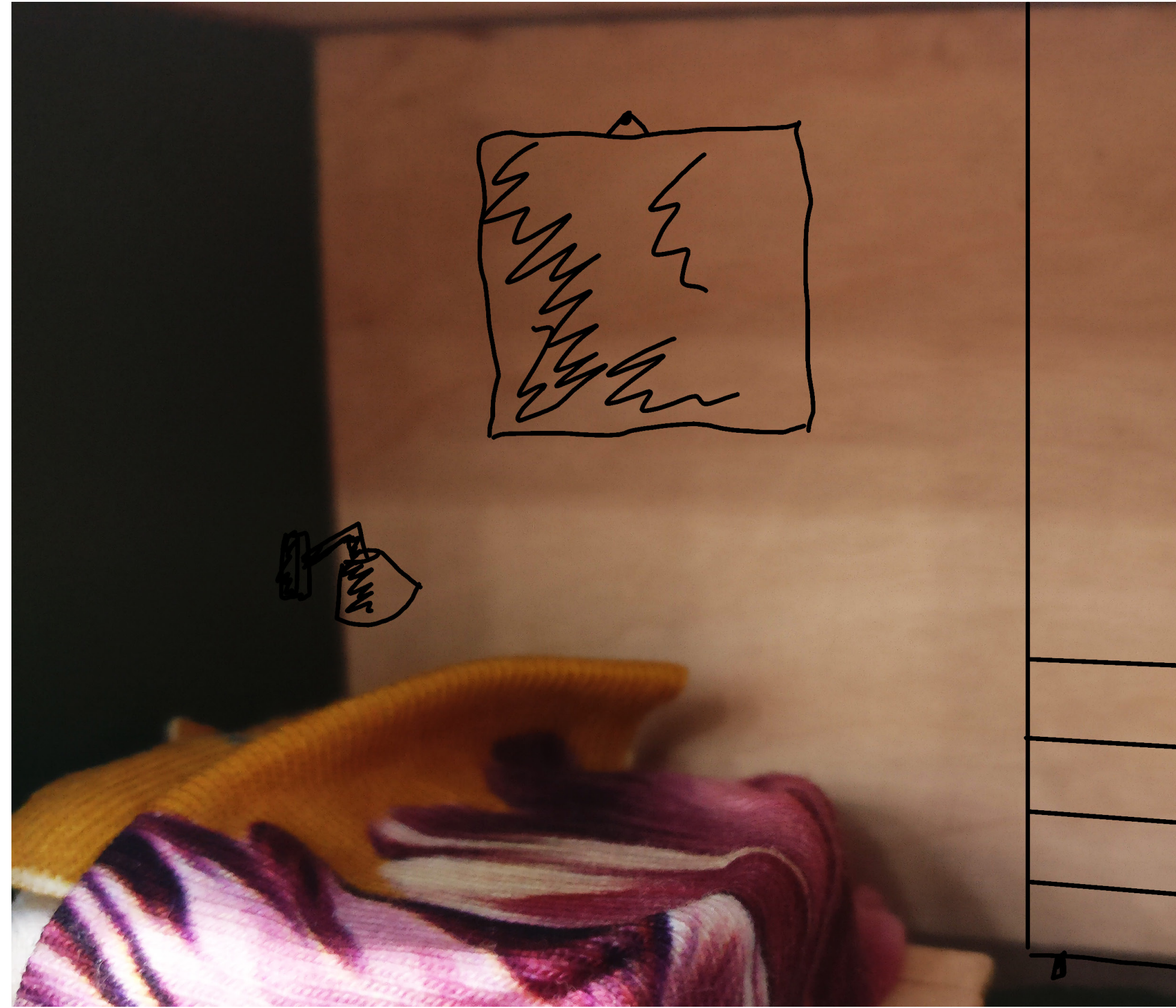

sound



light

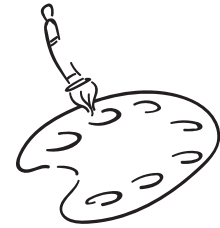

colour

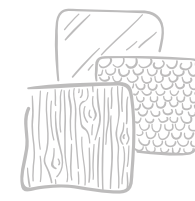

texture



smell



privacy



interaction



wayfinding

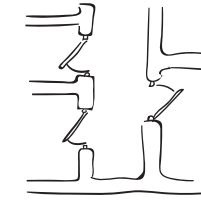

layout



personalisation



nature



comfort



routine



confidence



sound



light



colour

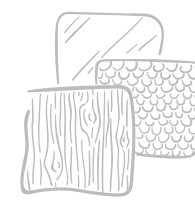

texture



smell



privacy



interaction

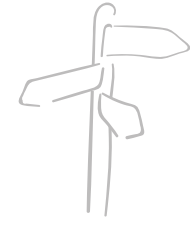

wayfinding

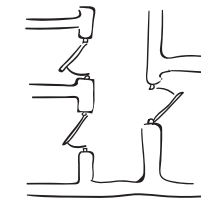

layout



personalisation



nature



comfort



routine



confidence

Emma

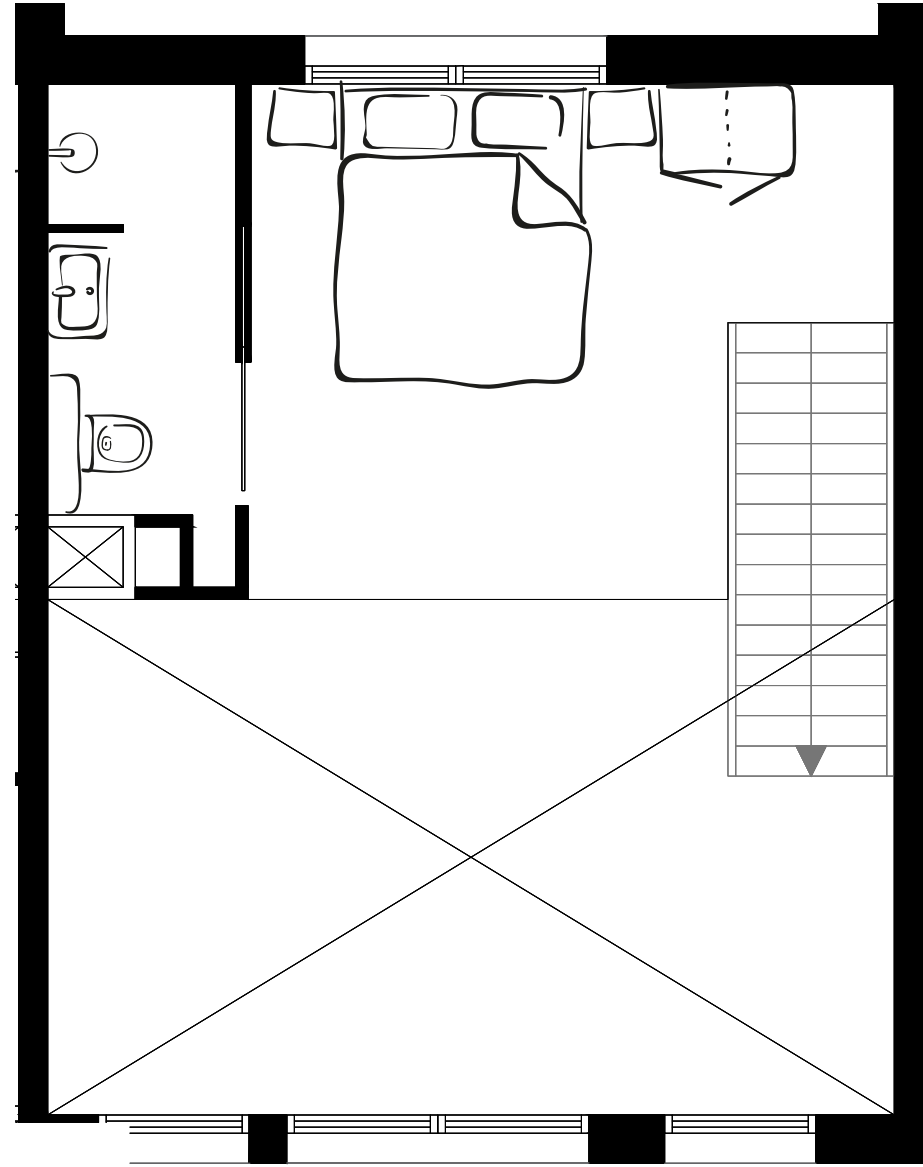
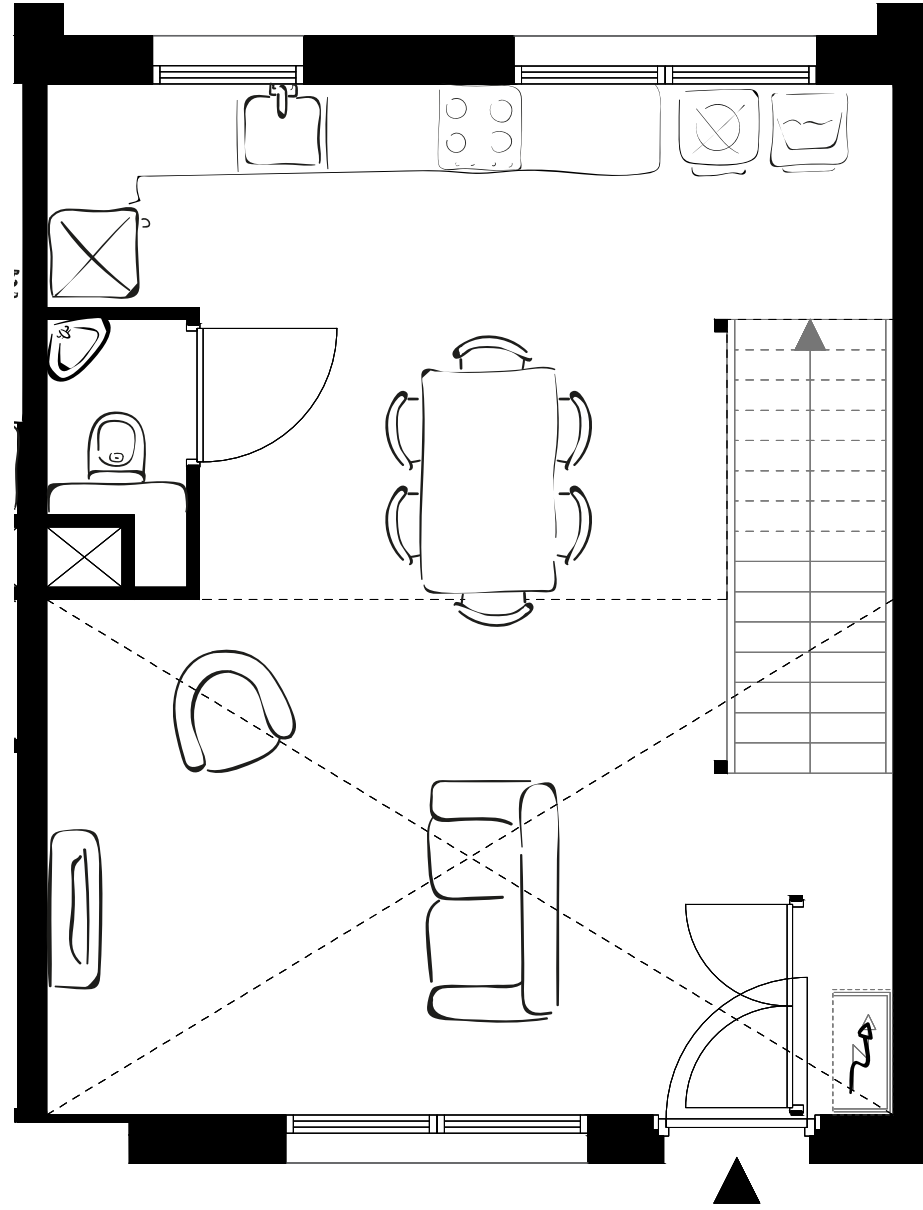

I like nice views  
and nature a lot!

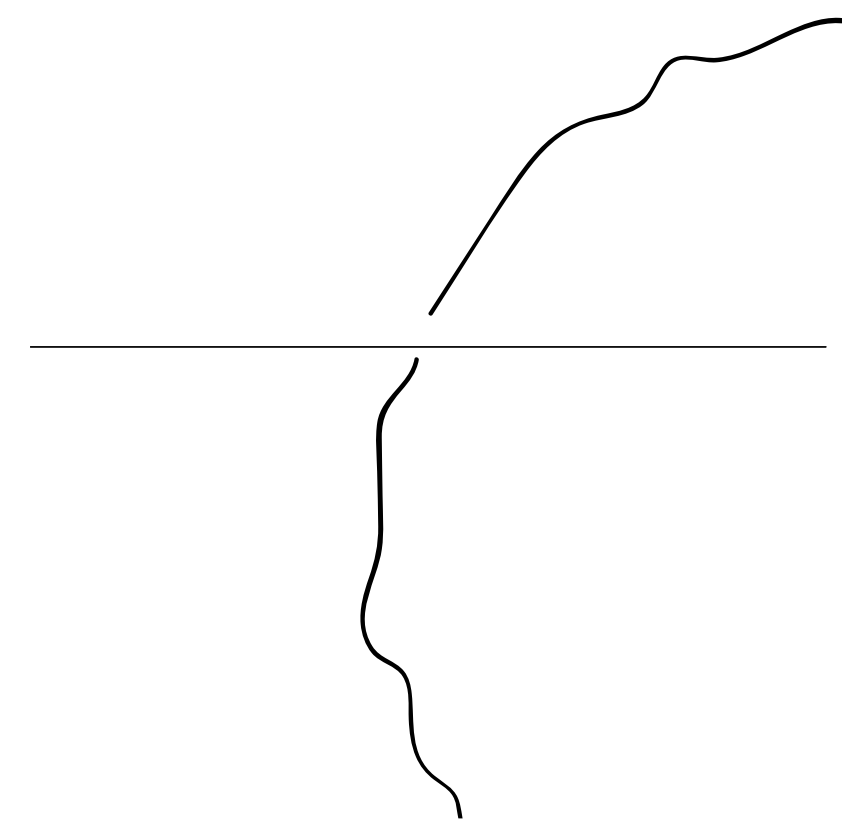
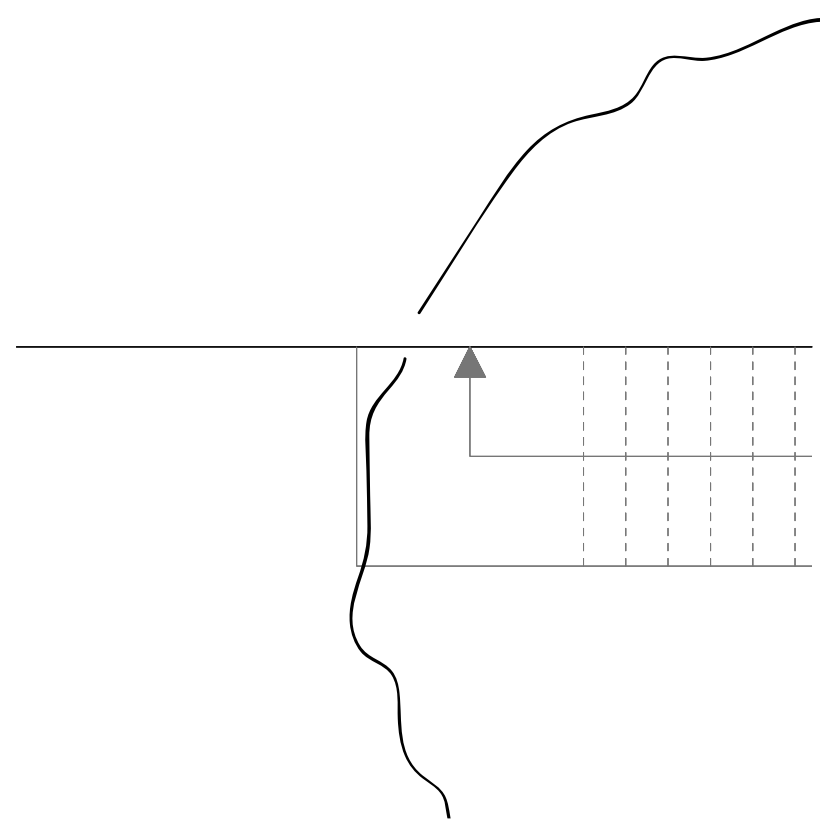

-   
sound
-   
light
-   
colour
-   
texture
-   
smell
-   
privacy
-   
interaction
-   
wayfinding
-   
layout
-   
personalisation
-   
nature
-   
comfort
-   
routine
-   
confidence

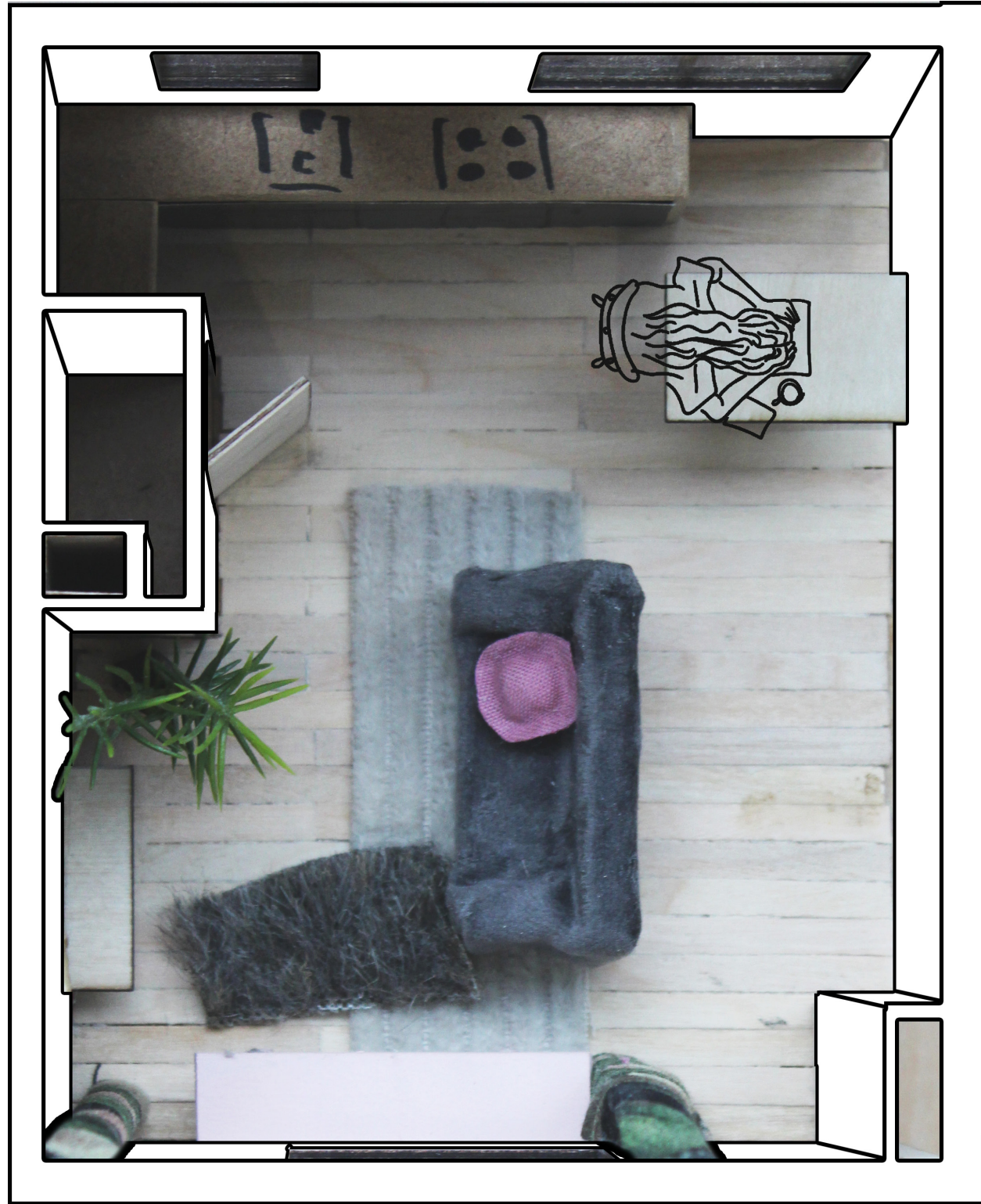

I really want nature around me as much as possible!



sound



light

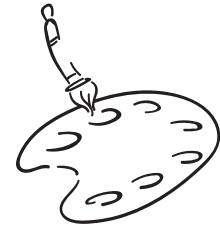

colour

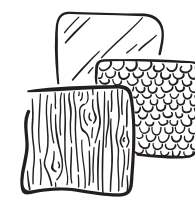

texture



smell



privacy



interaction

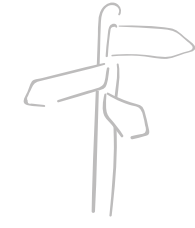

wayfinding

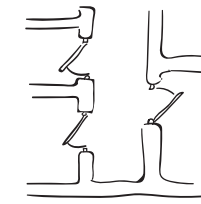

layout



personalisation



nature



comfort



routine



confidence



sound



light



colour

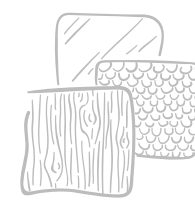

texture



smell



privacy



interaction

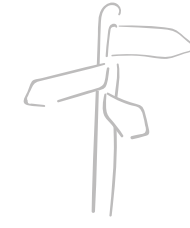

wayfinding

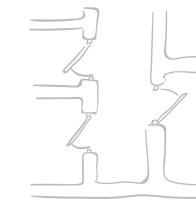

layout



personalisation



nature



comfort



routine



confidence



sound



light



colour

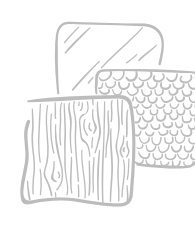

texture



smell



privacy

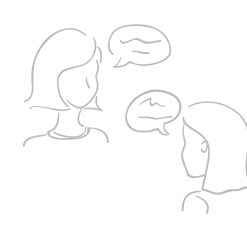

interaction

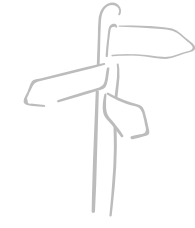

wayfinding

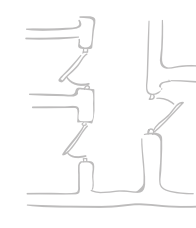

layout



personalisation



nature



comfort



routine



confidence



sound



light



colour

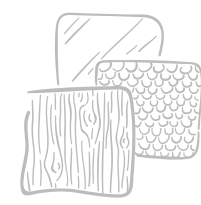

texture



smell



privacy



interaction

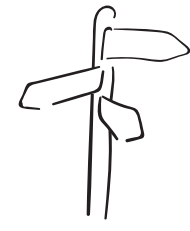

wayfinding

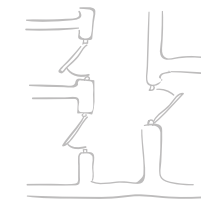

layout



personalisation



nature



comfort



routine



confidence



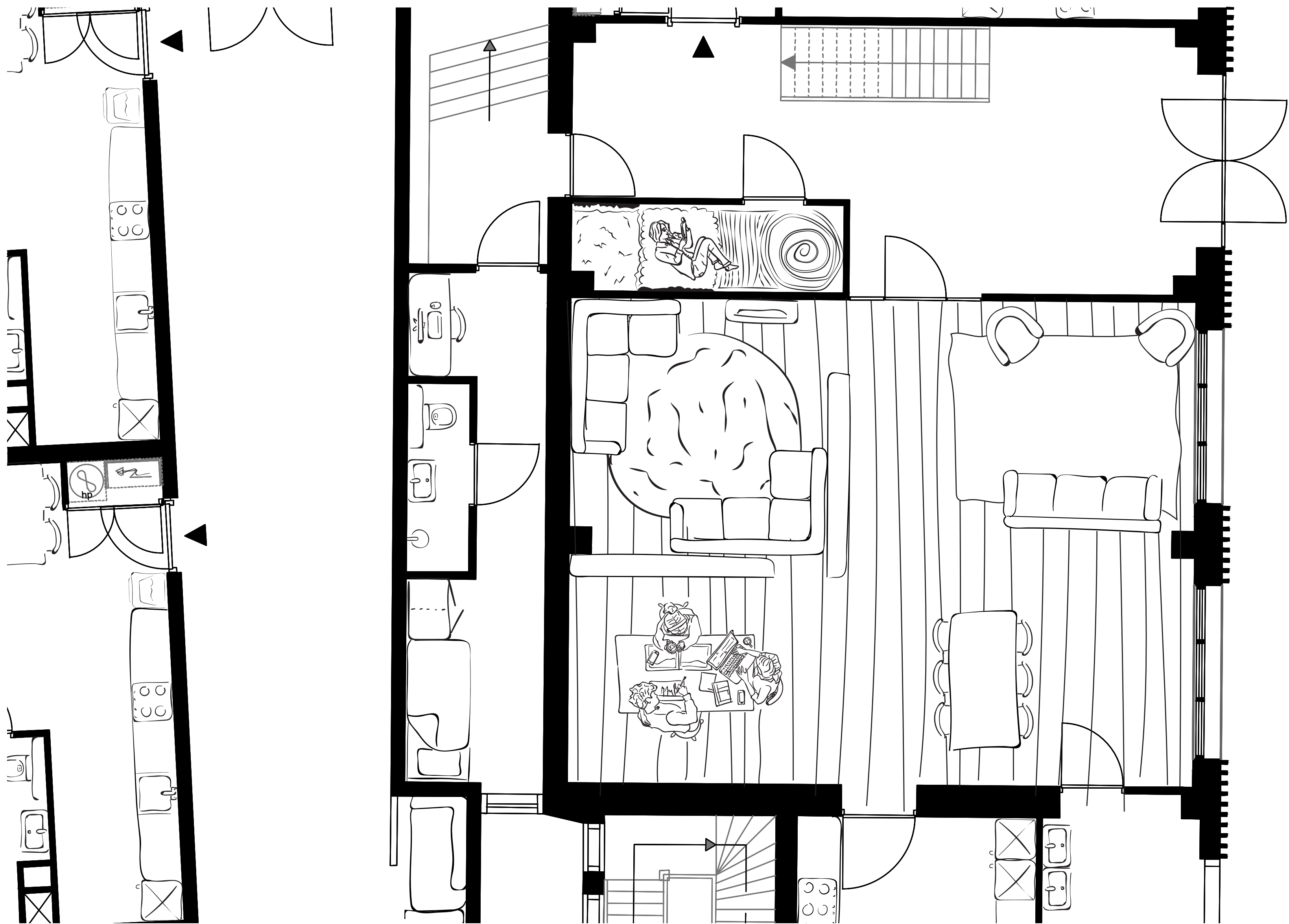

a texture room enables us to relax a little bit!

and the common room provides different levels of interaction and privacy!



sound



light



colour

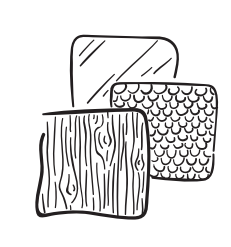

texture



smell



privacy

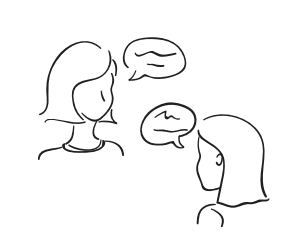

interaction



wayfinding

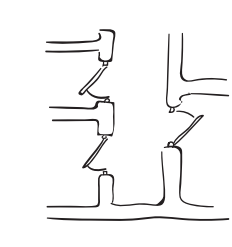

layout

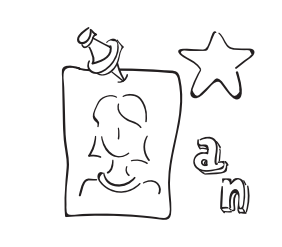

personalisation

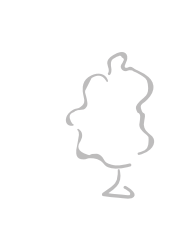

nature



comfort



routine



confidence

