

A Design Manual

towards

Sustainable & Lightweight

Temporary Structures

Technical Research Paper

Graduation Studio aE Intecture
January 2017

Design Mentor: Anne Snijders
Research Mentor: Martijn Stellingwerff

Manuella de M. M. Borges 4521463
M.deMeloMoraisBorges-1@student.tudelft.nl

Contents

Abstract	05
Introduction	06
Design Manual Methodology	07

PART 1: Materials Selection Tool

1. Materials Pre-selection	09
1.1 Problem Statement	
1.2 The Importance of Choosing the Right Materials	
1.3 Pre-selection Boundary Conditions	
1.4 Material pre-selection choice	
2. Evaluation Criteria	13
2.1 Criteria I: Material Performance	
2.2 Criteria II: Material Health	
2.3 Criteria III: Cost	
3. Data Collection	14
4. Comparative Analysis	16
4.1 Criteria I: Material Performance	
4.2 Criteria II: Material Health	
4.3 Criteria III: Cost	
5. Point System	17
5.1 Criteria I: Material Performance	
5.2 Criteria II: Material Health	
5.3 Criteria III: Cost	
6. Results Part 1	18
6.1 Results per Parameter - Bar Chart	
6.2 Results per Material - Linear Chart	
6.3 Final Results per Material	
7. Evaluation	21
7.1 Results Overall Observation	
7.2 Results Analytical Observation	

PART 2: Materials Design Tool

1. Tool Description	25
2. Sizes	26
2.1 Transportation as Boundary Conditions	
2.2 Handling on Site	
2.3 Beam Sizes and Sectional Profiles - up to 6 m span	
2.4 Beam Sizes and Sectional Profiles - up to 12 m span	
2.5 Beam Sizes and Sectional Profiles Calculations	
2.5.1 Calculations Methodology	
2.5.2 Calculations Table	

3. Connections	36
3.1 Connections using the same material as structure	
3.2 Connections using different material from structure	

PART 3: Case Studies

1. FRP (Fiber Reinforced Polymer) BIG Serpentine Pavillion	39
2. Bamboo & Laminated Bamboo German-Chinese House at Expo Shanghai	40
3. Cardboard & Laminated Wood Japanese Pavilion at EXPO Hanover	41

PART 4: Qualitative Analysis of a Selected Material

1. Material Selection Parameters	43
2. Sustainability	43
2.1 Why acetylated wood?	
2.2 Manufacturing	
2.3 Products & by-products	
3. Enhanced Quality	45
3.1 Knot-free timber	
3.2 Aesthetics	
3.3 Dimensional Stability	
4. Enhanced Performance	46
4.1 Durability	
4.2 Structural Performance Enhancement	
5. Lessons Learned	47
Conclusion	49
Bibliography	50
Appendix	53

Abstract

Temporary architecture permeates temporarily the cities we live in, whether it be as a response of a natural disaster, a showcase of technological innovation, a reaction to an environmentally sensitive site or simply built for a short lifespan. In a contradictory way, temporary architecture seems to be here to stay given that it is to some extent capable addressing the ever-changing needs of our societies, and their aspiration for flexibility and portability.

Despite the fact that temporary architecture is evolving, there is much room for improvement. While the focus is in the function it serves, it very commonly lacks in the aesthetic aspect, being perceived by many as cheap, fast and disposable. However, in the technical aspect, temporary architecture can be the grounds for experimentation of new materials and construction techniques, opening up a whole new realm of possibilities when it comes to designing lightweight structures. More so, it can spark the change into adapting materials that are more sustainable and with less environmental impact than steel and aluminum, for example.

Introduction

The objective of this design manual is to explore sustainable and lightweight materials and construction techniques that will enable to create temporary, flexible and demountable structures that can be used and re-used in different project scales.

Why Temporary?

Temporariness in architecture is still frowned upon by many architects as inferior and insignificant. Traditionally, architecture has carried the notion that in order to be considered good architecture it has to last. Longevity has been long aspired for as a synonym of robustness and successful implementation of good materials and techniques, ones that could withstand the passing of time. However, even though pop-up architecture can be often neglected, their innocent and ephemeral character hides an invisible, yet transformative power that can serve as catalysts for change.

While permanent, traditional architecture has to serve a purpose, a program, a group of stakeholders and users, pop-up architecture can focus on the experience of the space by being irreverent, playful and experimental. They carry with them the “dream of an escape, a removal from everyday routine” (Watson, 2015), pulling us away from the concrete, stone and glass buildings that we are so used to.

Why Sustainable?

Given the fact that the building stock “represents the largest financial, physical and cultural capital of the industrialized societies” (König, 2010, p.9), the construction industry gains special attention when it comes to sustainable development. In Europe, it is estimated that construction and demolition waste (CDW) accounts for nearly 25% to 30% of all waste that is produced (European Commission, 2016). As the projections in the construction industry only grow with new construction, renovation and demolition taking place on a fast pace, it is also expected that the amount of natural resource exploitation and waste production will grow with it, if a different method is not implemented.

In light of all this, the construction industry, including temporary buildings, needs to go through a transformation in the methods of thinking, managing resources and creating buildings with materials that have less embodied energy and construction techniques that will enable disassembly and re-use. This way, it will be possible to reduce the extraction of new material resources, demolition waste, construction time and transportation costs, while ensuring that these structures have a new purpose beyond its planned lifespan.

Why Lightweight?

In order to ensure that temporary building structures can be properly assembled, disassembled, transported to a new location and re-used, it is important that it is lightweight. The lighter it is, the easier it will make the whole process, reducing manpower, lifting equipment and transportation costs. Efficiency is the key; therefore, lightness will be sought for from the very core of each material that is analyzed, as well as easy assembly methods.

Overall design question

How can temporary architecture for large scale international events be designed to be easily assembled and disassembled in order to adapt to different programmatic needs and project scales, or re-used in a different setting when its temporary need has ceased to exist?

Thematic Research Question

Which technologies and techniques will allow for the creation of eco-friendly temporary and flexible architecture?

- What **material(s)** will be most suitable for the creation of lightweight and demountable structures that have low environmental impact?
- What would be the optimal **sizes** for ease of handling and transportation?
- What assembly/disassembly methods and **connections** will be most suitable?

Design Manual Methodology

This design manual aims to explore different lightweight materials that can be used as alternatives to the most common materials currently used in temporary structures: steel and aluminum. In order to facilitate navigation, it has been divided into 4 parts:

PART 1: Materials Selection Tool

The utilized method will serve as a tool to compare the alternative materials to the structural performance of steel and aluminum, while showcasing more sustainable options and gauging the associated cost with each one of them. A final evaluation will be done to highlight the strengths and weaknesses of each material helping the designer to make a safe and sound choice.

PART 2: Materials Design Tool

In order to design sustainable and lightweight temporary structures two main criteria will be investigated: lightness and demountability. Each material will be illustrated with possible sizes and connections, along with an estimation of weight and cost.

PART 3: Case Studies

A few case studies will show the possible applications of the materials analyzed.

PART 4: Qualitative Analysis of a Selected Material

In order to investigate its full potential for designing a sustainable and lightweight temporary structure, one material will be studied further based on the possible scenarios created on PART 1 and further comparison on PART 2. Furthermore, a qualitative analysis will be done including sustainability considerations and aesthetics.

PART 1: Materials Selection Tool

1. Materials Pre-selection

1.1 Problem Statement

In the world of temporary architecture, especially in commercial uses, steel and aluminum have been largely used in structures that can be easily assembled and disassembled, such as in tents, canopies, halls and construction scaffolding. While their structural efficiency is not questioned, their environmental footprint leaves room for much debate.

When looking at material streams at the Building Sector, a study entitled "Resource Efficiency in the Building Sector" done by Ecorys indicates that concrete, aggregate materials and bricks make up 90% of the total amount of materials used in the construction industry in Europe, while wood only accounts for 2% or less. In terms of embodied energy, steels and aluminum together represents 51% of the total embodied energy in building materials with an additional 17% for concrete (Ecorys, 2014). Therefore, these facts left me with two alarming conclusions: a) That the most common materials used in the building construction sector produce the most amount of waste; b) That the most common materials used in the building construction sector have the highest embodied energy values.

1.2 The Importance of Choosing the Right Materials

While attending a lecture at the New World Campus in The Hague, the speaker Gert-Jan Vroege from SGS Search emphasized that in the future more attention will need to be paid to the embodied energy of the materials, rather than in the operational energy needed to run buildings. His preoccupation is shared with other scientists and consultant firms, such as Simons Group and Dcarb8. They believe that in the future, buildings will become more energy efficient given the strict regulations and technological advancements. However, the embodied energy of building materials will make-up a much greater percentage of the building's total lifetime carbon footprint if the figures stay the same (Lane, 2007).

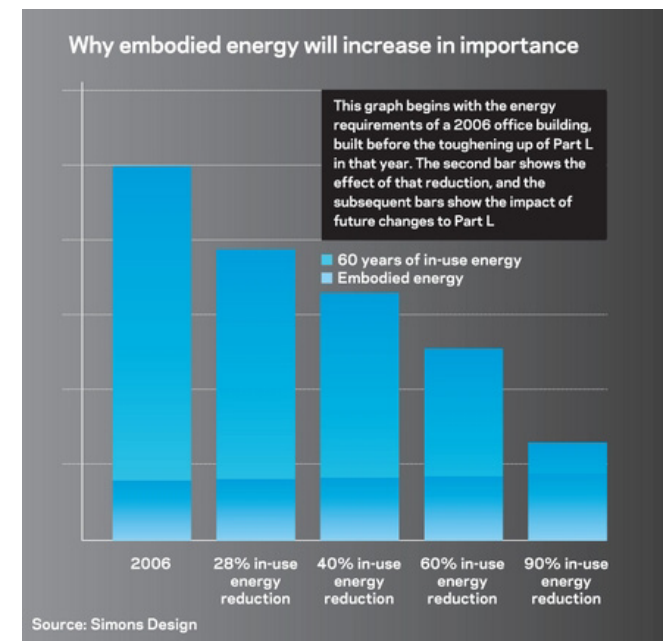

Figure 01 - Embodied Energy Analysis.
Source: <http://www.bdonline.co.uk/>

This graph exemplifies how operational energy use are reducing, while embodied energy of materials remains the same. In this example, the ratio of operational to embodied energy changed from being 80:20 to being 40:60 (Lane, 2007). Therefore, this graph showcases the importance of considering embodied energy of materials, its manufacture, transportation and installation as key factors in order to build sustainable buildings.

For Gert-Jan Vroege from SGS Search, the matter is no longer about operational energy in the building sector, but about materials and their embodied energy (Vroege, 2016). Therefore, designers should evaluate the material health and investigate what qualities the chosen material has that will enable it to last longer. In order to achieve a longer lifespan, materials have to be easily maintained and most importantly keep its quality so it can be re-used before it is recycled, downcycled or biodegraded. In fact, the Ellen MacArthur Foundation (Ellen MacArthur Foundation, 2013) describes the four principles for a circular economy and how they can save value:

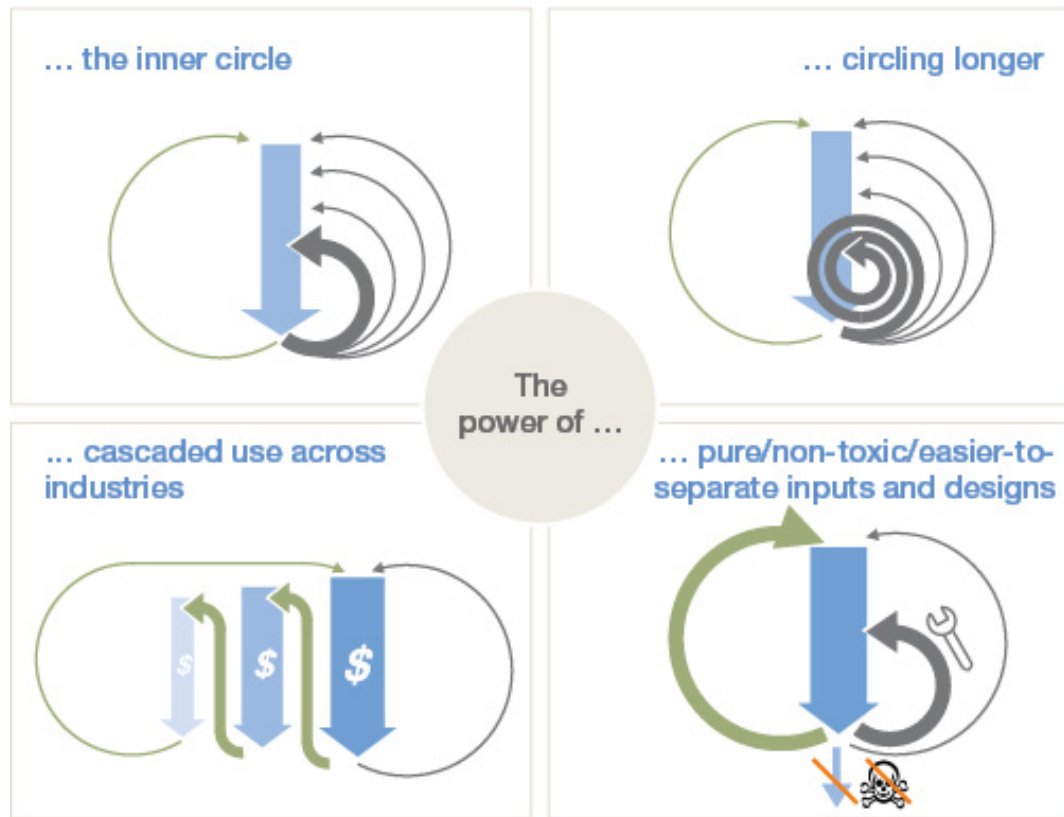

Figure 02 - Four Principles for Circular Economy
Source: Ellen MacArthur Foundation

From all the four circles, the Pure Circle is the one that is the most difficult to achieve and it consists of re-using materials that have kept its quality. This circle is, however, the most difficult to achieve for a few reasons: it is hard to predict future uses; and it needs to be implemented in designs that can be disassembled.

Therefore, the importance of choosing the right materials is the very foundation towards achieving a circular design. As defined by the Ellen MacArthur Foundation "Circular design, i.e., improvements in material selection and product design (standardisation/modularisation of components, purer material flows, and design for easier disassembly) are at the heart of a circular economy" (Ellen MacArthur Foundation, 2013).

While Circular Design might be harder to achieve for permanent structures that have long lifespans, it is important to consider it in the design of temporary structures that have shorter lifespans and offer more room for experimentation and innovation.

1.3 Pre-selection Boundary Conditions

Since the challenge to build sustainable and temporary architecture demands lightweight and strong structures with lower environmental footprint, a few boundary conditions were initially established for the pre-selection of materials:

- Lighter than aluminum and steel: Density below 2000kg/m³
- Strength (Flexural) as close as possible to aluminum and steel (which range from 50MPa and 2200 MPa)
- Less embodied energy than aluminum and steel: below 30MJ/kg

Figure 03 shows the materials universe in CES Edupack before any selection criteria is established. The plotted graph shows Density x Flexural Strength (MoR). Similarly, Figure 04 shows the same parameters, but this time a few materials that can be used in lightweight structures were selected in order to compare its strength-to-weight ratio. Lastly, Figure 05 shows the embodied energy parameter plotted against density. Here, it is possible to see that natural materials have the least embodied energy (and density), while composite materials have similar embodied energy to metal and alloys.

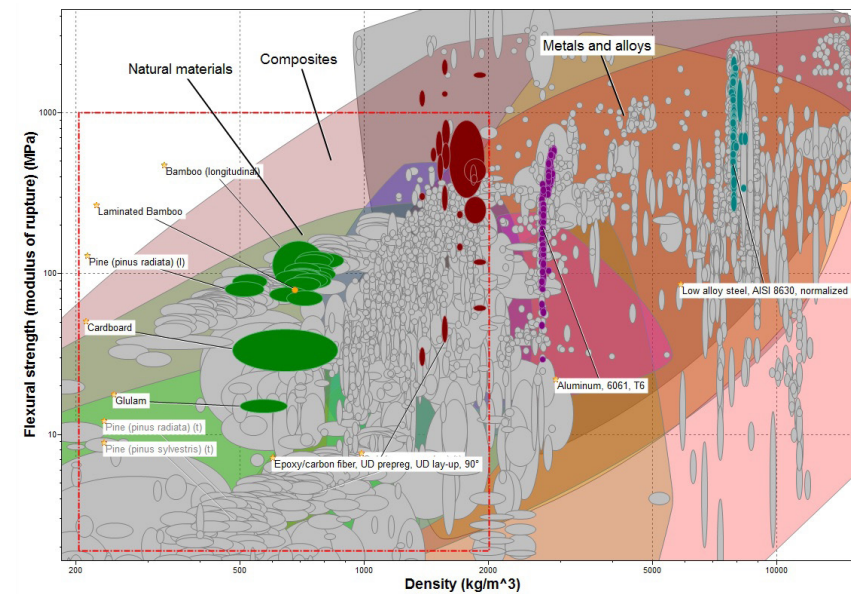

Figure 03 -Material Universe before boundary conditions | Source: CES Edupack (author's analysis)

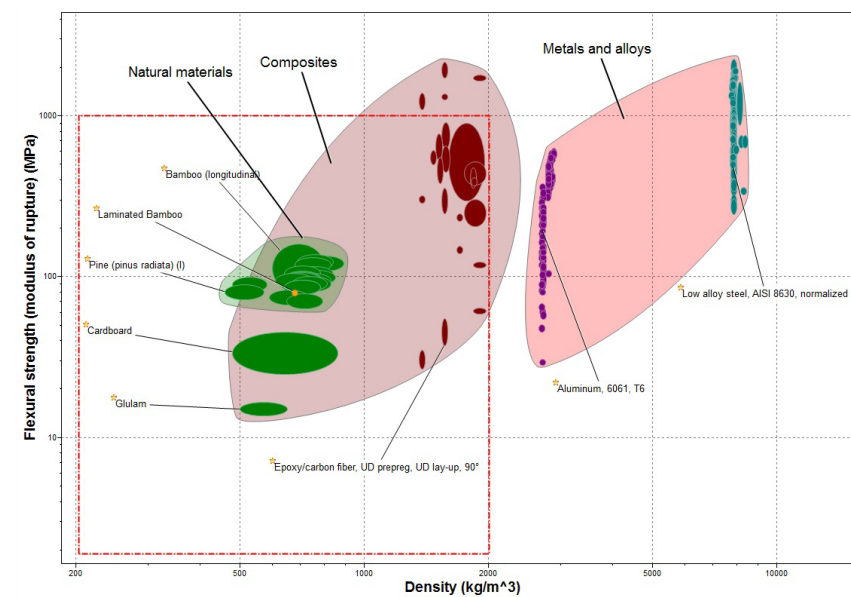

Figure 04 - Density x Flexural Strength boundary conditions | Source: CES Edupack (author's analysis)

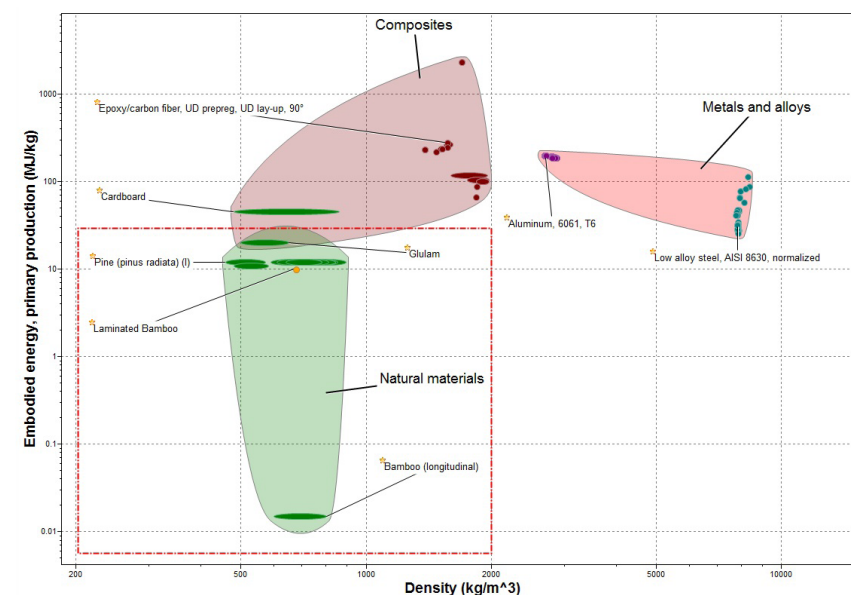

Figure 05 -Density x Embodied energy boundary conditions | Source: CES Edupack (author's analysis)

1.4 Material Pre-selection Choice

In the world of temporary architecture, especially in commercial uses, steel and aluminum have been largely 1.4 Material Pre-selection Choice

In the previous chapters, we have learned that the most commonly used materials in the building sector have the highest embodied energy. However, concrete, aggregate materials and bricks are not part of this study given that they are not appropriate for lightweight temporary structures. Hence, steel and aluminum become the focal point from which comparisons are drawn in order to find alternative materials for lightweight and sustainable temporary structures.

In order to find alternative materials that can perform well and offset the use of traditionally used materials in lightweight temporary architecture, different categories were investigated, where two distinct materials (that are typically used for construction purposes) were selected to represent each category:

Most Used Materials	Alternative Materials
1) Metals & Alloys - Steel (AISI 8630) - Aluminum (Al 6061)	2) Composites - Fiber Reinforced Composite (EP-CF70) - Cardboard (CES Edupack standard)
	3) Natural Materials - Wood (Radiata Pine) - Bamboo (CES Edupack standard)
	4) Engineered Materials - Laminated Wood (acetylated Radiata Pine) - Laminated Bamboo (Moso)

by author

2. Evaluation Criteria

The previous graphs were generated from the software CES Edupack. Since using this software demands a higher knowledge for the common user and designer, requiring numeric inputs, multiple phases of filtering and comparing data in order to get to a desired result, a user-friendly and more visual method was developed in this Design Manual, which aims to aid designers in the selection of a material, its sizes and connections. In order to develop the material selection tool, a multi-criteria analyses was created to help visualize the important factors in a better way. Therefore, three main criteria were considered: material performance, material health and cost.

Each criterion encompassed multiple parameters that together would inform the performance, quality or range desired in each one. In order to determine what and how many parameters would be chosen in each category, the following steps were considered:

- 1) An analysis was conducted in CES Edupack using graphs and comparing data;
- 2) Data was collected into an excel spreadsheet and information was added based on multiple researches in addition to CES Edupack;
- 3) Data was compared in the excel spreadsheet;
- 4) A point system was established in order to equally rank several different parameters with different unit values;
- 5) The point system was tested and results were analyzed to verify its validity;
- 6) The point system ranking was transformed into a performance ranking;
- 7) The performance ranking of the three established criteria would together inform possible what-if scenarios. For example, a material that has good structural performance might also be expensive, etc.

The three criteria considered were:

2.1 Criteria I: Material Performance

Evaluates the mechanical and thermal performance of the material, where lightness, strength and thermal conductivity (which informs the R-Value of the material depending on its thickness) were considered. The 7 parameters were:

Material Performance
Density (kg/m ³)
Flexural Strength - MoR (Mpa)
Strength-to-weight ratio (MoR/density)
Young's Modulus - MoE (GPa)
Compressive Strength (Mpa)
Tensile Strength (Mpa)
Thermal Conductivity (W/m.oC)

by author

2.2 Criteria II: Material Health

Evaluates the material health and sustainability in regards to embodied energy, CO2 footprint, recyclability, renewability and end-of-life uses (combustible, biodegradable or landfill).

Material Health
Embodied Energy (MJ/kg)
CO2 footprint (kg/kg)
Water Usage (l/kg)
Recycle fraction current supply (%)
Combust for Energy Recovery (yes/no)
Biodegradable (yes/no)
Renewable Content (%)

by author

2.3 Criteria III: Cost

Evaluates the cost in euros per unit mass of material (EUR/kg).

3. Data Collection

Data was collected using multiples sources: CES Edupack software, suppliers, research papers and calculations.

After gathering data, they were transformed into one single numeric value that was obtained by finding the midrange number between the highest and the lowest values assigned to each specific material. Other parameters utilized a "yes" or "no" answer. Then, a master list was created in order to be able to easily assess and compare them.

Note: Since most data was obtained from the CES Edupack software, the remaining data, especially for laminated bamboo and laminated wood (which used acetylation technique), was collected from several researches and supplier's data and then compared to similar materials in CES Edupack software in order to validate them. This comparison resulted in some minor adjustments, given that the numeric values in CES Edupack were much higher for all the materials than other researches proposed.

Properties	Units	min	max	midrange	min	max	midrange	min	max	midrange	min	max	midrange	min	max	midrange	min	max	midrange	min	max	midrange	min	max	midrange	
CRITERIA 1 - Material Performance																										
Reference Material		Steel AISI 8630	Steel AISI 8630	Steel AISI 8630	Aluminum Al 6061	Aluminum Al 6061	Aluminum Al 6061	FRP EP-CF70	FRP EP-CF70	FRP EP-CF70	Cardboard CES database	Cardboard CES database	Cardboard CES database	Wood Pinus Radiata	Wood Pinus Radiata	Wood Pinus Radiata	Laminated Wood Accoya + CES	Laminated Wood Accoya + CES	Laminated Wood Accoya + CES	Bamboo (longitudinal) CES database	Bamboo (longitudinal) CES database	Bamboo (longitudinal) CES database	Laminated Bamboo Moso Bamboo	Laminated Bamboo Moso Bamboo	Laminated Bamboo Moso Bamboo	
Density	kg/m3	7800	7900	7850	2670	2730	2700	1550	1580	1565	480	860	670	460	570	515	460	570	515							686 *
Flexural Strength (MoR)	Mpa	620	760	690	193	290	241,5	37,7	55,1	46,4	25	45	35	72,6	88,7	80,65	72,6	88,7	80,65	80	160	666	120	77	83	80 *
Strength-to-weight ratio	MoR/density			0,088			0,089			0,030			0,052		0,157			0,157				0,180				0,117
Young's Modulus (MoE)	Gpa	201	212	206,5	68	74	71	8,5	8,5	8,5	3	8,9	5,95	10,1	12,3	11,2			12,11	15	20	17,5	11	13	12 **	
Compressive Strength	Mpa	620	760	690	207	290	248,5	213	252	232,5	41	55	48	37,7	46,1	41,9			47,89	600	100	350			77 *	
Tensile Strength	Mpa	690	855	772,5	241	320	280,5	46,8	56,7	51,75	23	51	37	67,5	82,5	75			102,86	160	320	240			90 *	
Thermal Conductivity	W/m.oC	37	47	42	152	169	160,5	0,75	1,13	0,94	0,06	0,17	0,115	0,23	0,28	0,255	0,23	0,28	0,255	0,16	0,18	0,17			0,14 **	
CRITERIA 2 - Material Health																										
Reference Material		Steel AISI 8630	Steel AISI 8630	Steel AISI 8630	Aluminum Al 6061	Aluminum Al 6061	Aluminum Al 6061	FRP EP-CF70	FRP EP-CF70	FRP EP-CF70	Cardboard CES database	Cardboard CES database	Cardboard CES database	Wood Pinus Radiata	Wood Pinus Radiata	Wood Pinus Radiata	Laminated Wood Accoya + CES	Laminated Wood Accoya + CES	Laminated Wood Accoya + CES	Bamboo (longitudinal) CES database	Bamboo (longitudinal) CES database	Bamboo (longitudinal) CES database	Laminated Bamboo Moso Bamboo	Laminated Bamboo Moso Bamboo	Laminated Bamboo Moso Bamboo	
Embodied Energy	MJ/kg	30,8	33,9	32,35	190	210	200	283	290	286,5	43,9	48,4	46,15	11,6	12,8	12,2	11,6	12,8	12,2	0,0143	0,0158	0,01505				6,11505
CO2 footprint	kg/kg	2,26	2,49	2,375	12,5	13,8	13,15	17,9	19,7	37,6	0,961	1,06	1,0105	0,574	0,633	0,6035	0,574	0,633	0,6035	0,00194	0,00214	0,00204				0,7
Water Usage	l/kg	47,4	52,3	49,85	1130	1250	1190	1343	1480	1411,5	88,9	98,3	93,6	665	735	700	665	735	700	665	735	700	665	735	700	700
Recycle fraction in current supply	%	39,9	44	41,95	40,5	40,5	44,7			0,1	68,4	75,6	72	8,55	9,45	9	8,55	9,45	9	1,34	1,48	1,41				0
Combust for Energy Recovery	yes/no			no			no			yes			yes			yes			yes			yes				yes
Biodegradable	yes/no			no			no			no			yes			yes			yes			yes				yes
Renewable Content	%			0			0			10			85			100			100			100				100
CRITERIA 3 - Cost																										
Reference Material		Steel AISI 8630	Steel AISI 8630	Steel AISI 8630	Aluminum Al 6061	Aluminum Al 6061	Aluminum Al 6061	FRP EP-CF70	FRP EP-CF70	FRP EP-CF70	Cardboard CES database	Cardboard CES database	Cardboard CES database	Wood Pinus Radiata	Wood Pinus Radiata	Wood Pinus Radiata	Laminated Wood Accoya + CES	Laminated Wood Accoya + CES	Laminated Wood Accoya + CES	Bamboo (longitudinal) CES database	Bamboo (longitudinal) CES database	Bamboo (longitudinal) CES database	Laminated Bamboo Moso Bamboo	Laminated Bamboo Moso Bamboo	Laminated Bamboo Moso Bamboo	
Cost	EUR/kg	0,651	0,697	0,674	2	2,35	2,175	34,3	38,1	36,2	0,6	1,37	0,985	1,23	1,84	1,535				3,1			2,48			10,05

by author

* Sharma et al., 2015

** Sullivan, 2016

4. Comparative Analysis

In order to compare all the numeric values for each criterion, graphs were created and a logarithmic scale was used since values ranged from 0,001 to 10000.

4.1 Criteria I: Material Performance

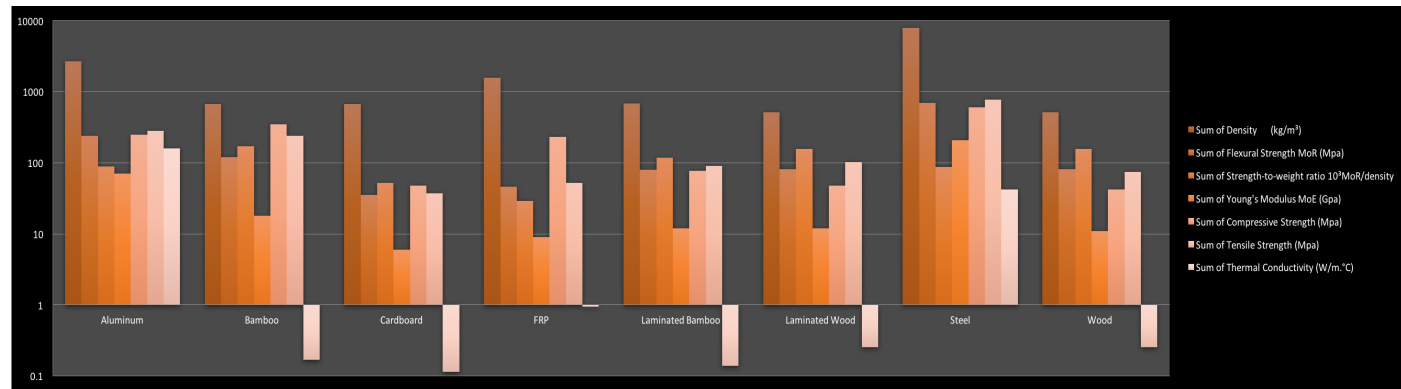

by author

4.2 Criteria II: Material Health

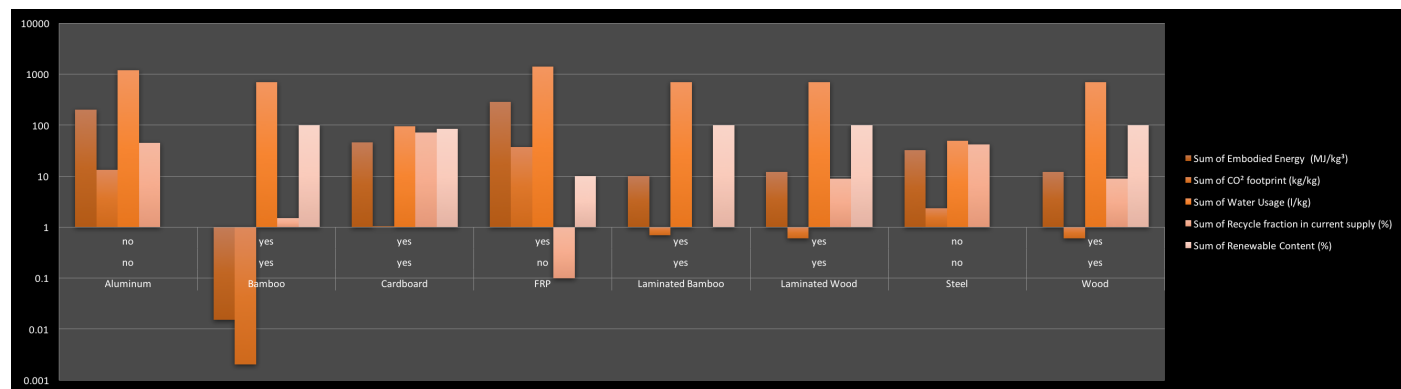

by author

4.3 Criteria III: Cost

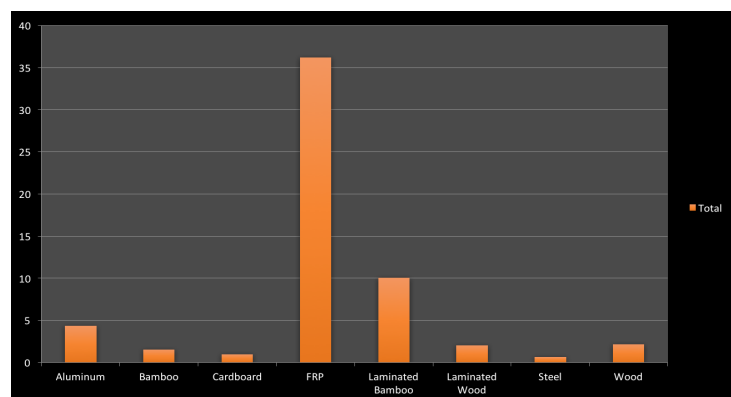

by author

5. Point System

The numeric values previously analyzed were transformed into point values in order to easily compare various parameters with distinct units and range. The scoring system worked as such:

a) Numeric values were transformed into comparative rating, where best performing material scores the highest points.

b) Points were assigned from 1 to 8 (eight materials selected, therefore the best performing material scores eight, whereas the worst performing material scores one)

c) Points were added for all parameters in each material and sum translated into performance rating (excellent, good, poor)

d) Combination of performance rating transformed into possible what-if scenarios

5.1 Criteria I: Material Performance

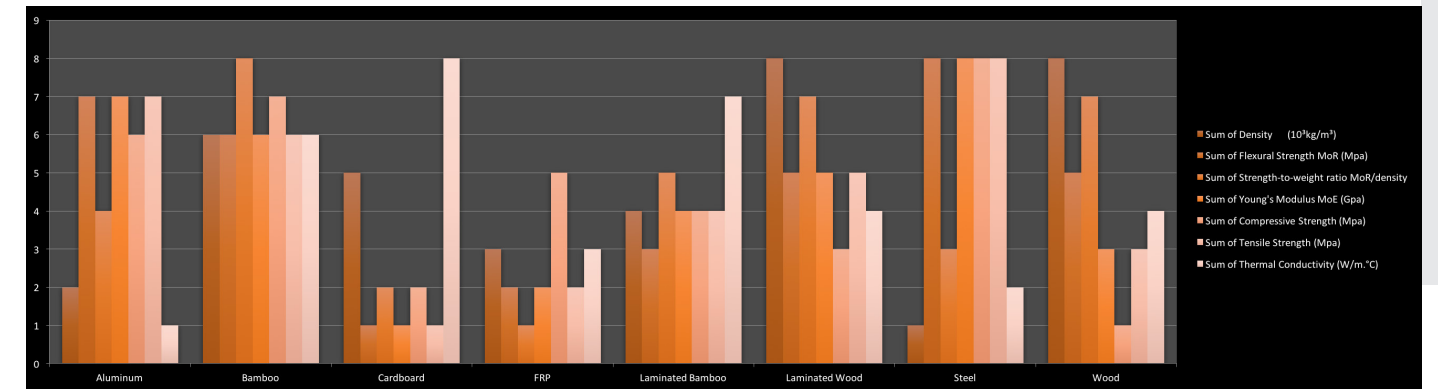

by author

5.2 Criteria II: Material Health

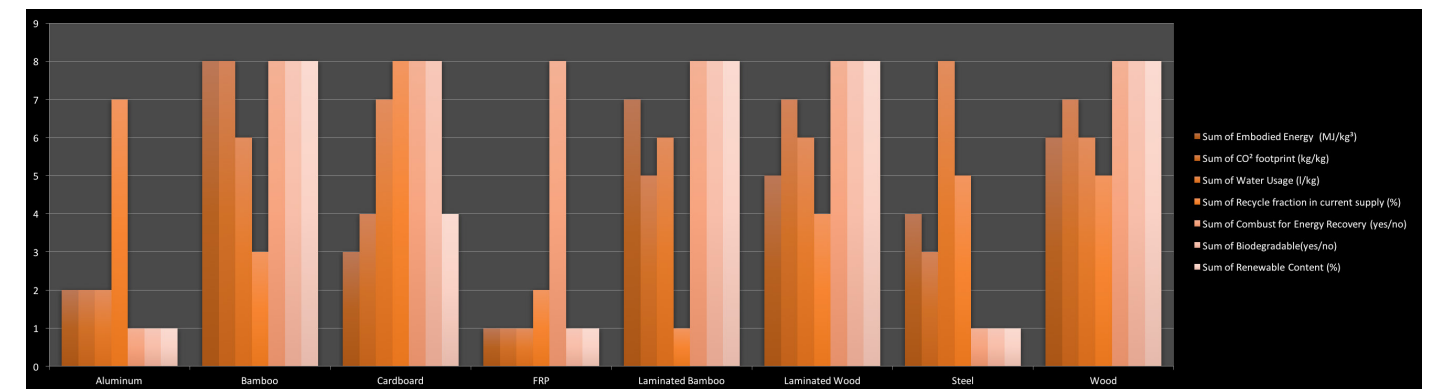

by author

5.3 Criteria III: Cost

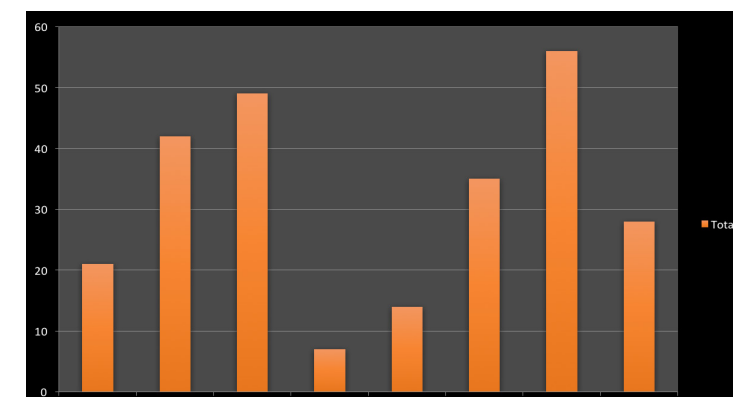

by author

6. Results Part 1

The following graphs are a summary of the points that each material obtained in all the parameters of the three analysed criteria.

6.1 Results per Parameter - Bar Chart

Criteria I: Material Performance

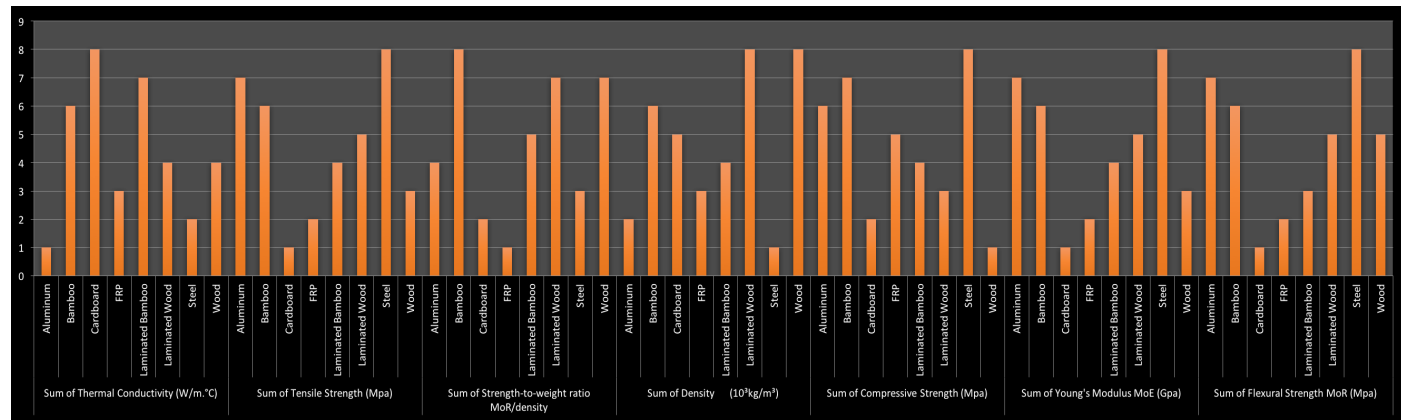

by author

6.2 Results per Material - Linear Chart

Criteria I: Material Performance

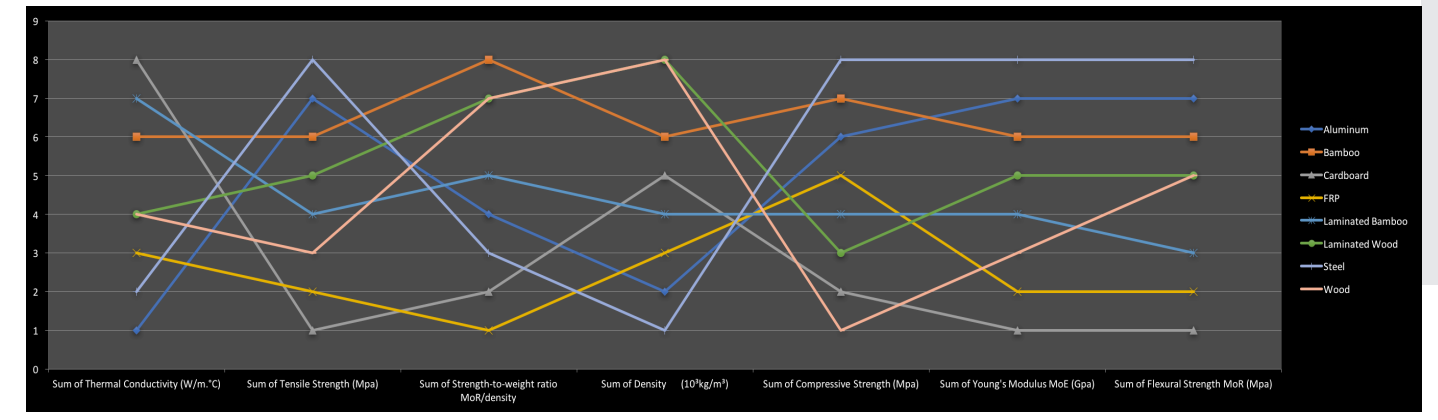

by author

Criteria II: Material Health

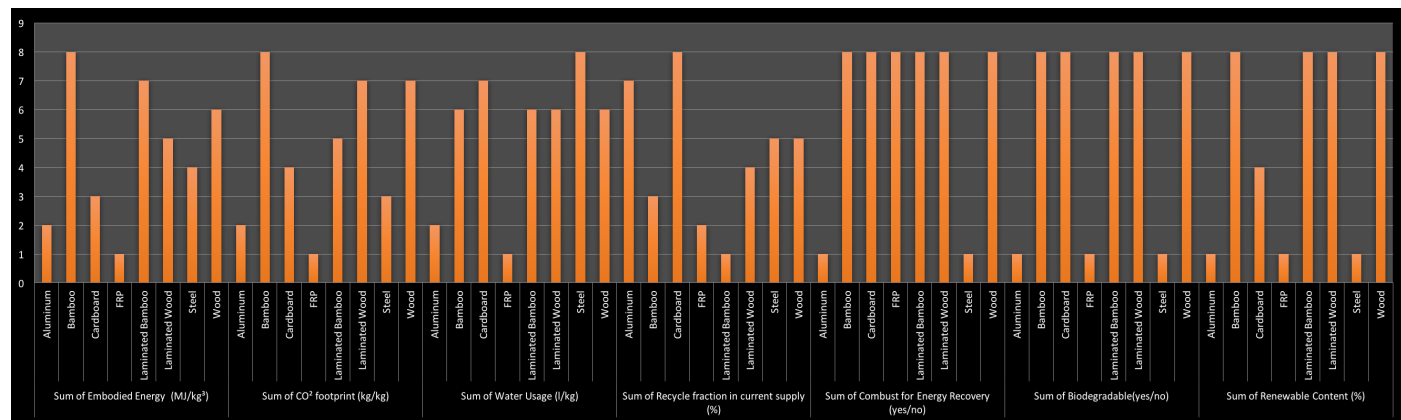

by author

Criteria II: Material Health

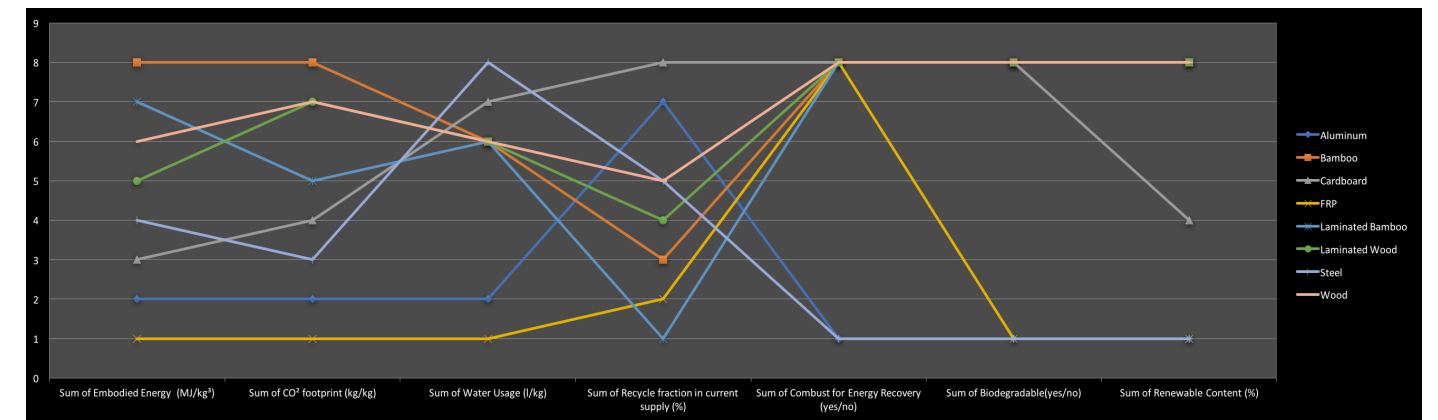

by author

Criteria III: Cost (numeric value & point system)

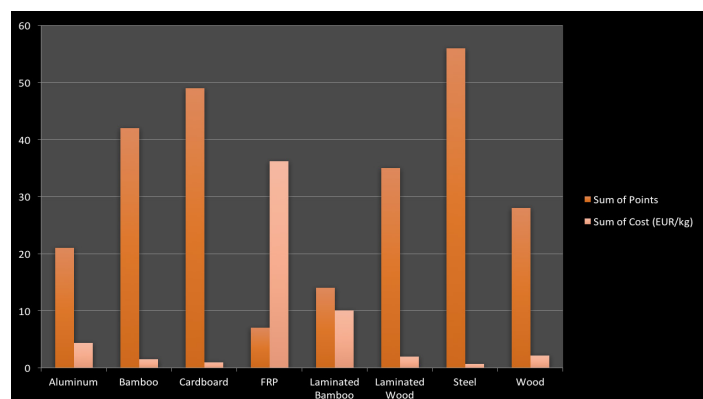

by author

Criteria III: Cost

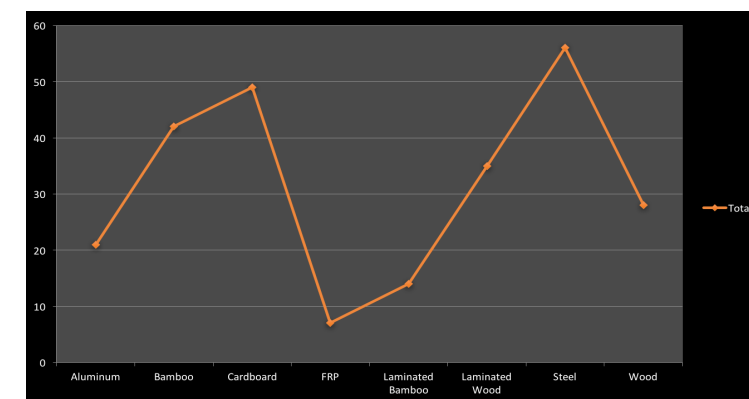

by author

6.3 Final Results per Material

Sum of Points - Linear Chart

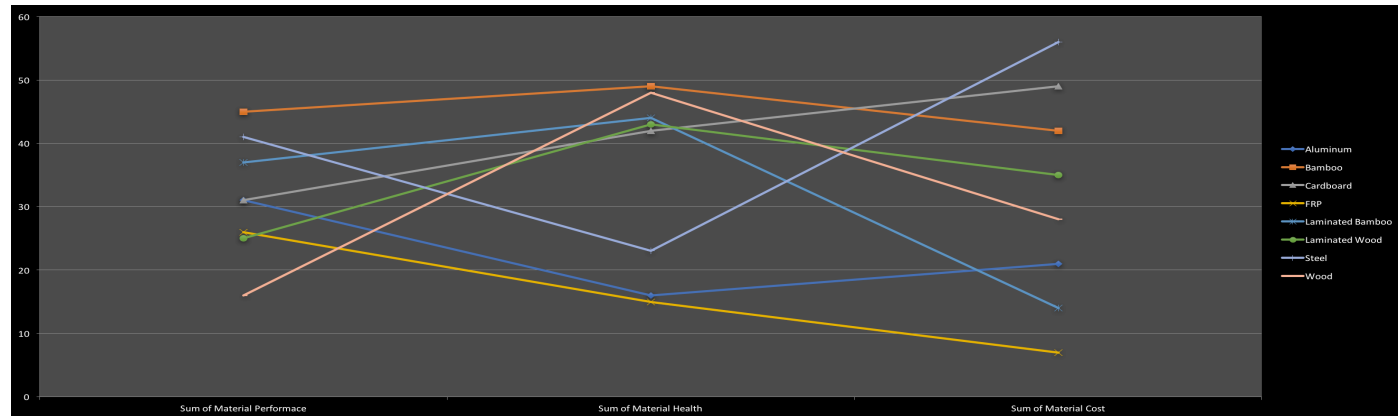

by author

The sum of points was translated as such:

Criteria I: Material Performance	Criteria II: Material Health	Criteria III: Cost
Poor: 1 – 18 points	Poor: 1 – 18 points	Expensive: 1 – 18 points
Good: 19 – 36 points	Good: 19 – 36 points	Reasonable: 19–36 points
Excellent: 37 – 56 points	Excellent: 37 – 56 points	Cheap: 37 – 56 points

by author

Final results per material & possible scenarios:

Sum of Points			
Material	Performance	Health	Cost
Aluminum	31	16	21
Bamboo	45	49	42
Cardboard	31	42	49
FRP	26	15	7
Laminated Bamboo	37	44	14
Laminated Wood	25	43	35
Steel	41	23	56
Wood	16	48	28

Results = Possible Scenarios			
Material	Performance	Health	Cost
Aluminum	Good	Poor	Reasonable
Bamboo	Excellent	Excellent	Reasonable
Cardboard	Good	Excellent	Cheap
FRP	Good	Poor	Expensive
Laminated Bamboo	Good	Excellent	Expensive
Laminated Wood	Excellent	Excellent	Reasonable
Steel	Excellent	Good	Cheap
Wood	Good	Excellent	Cheap

by author

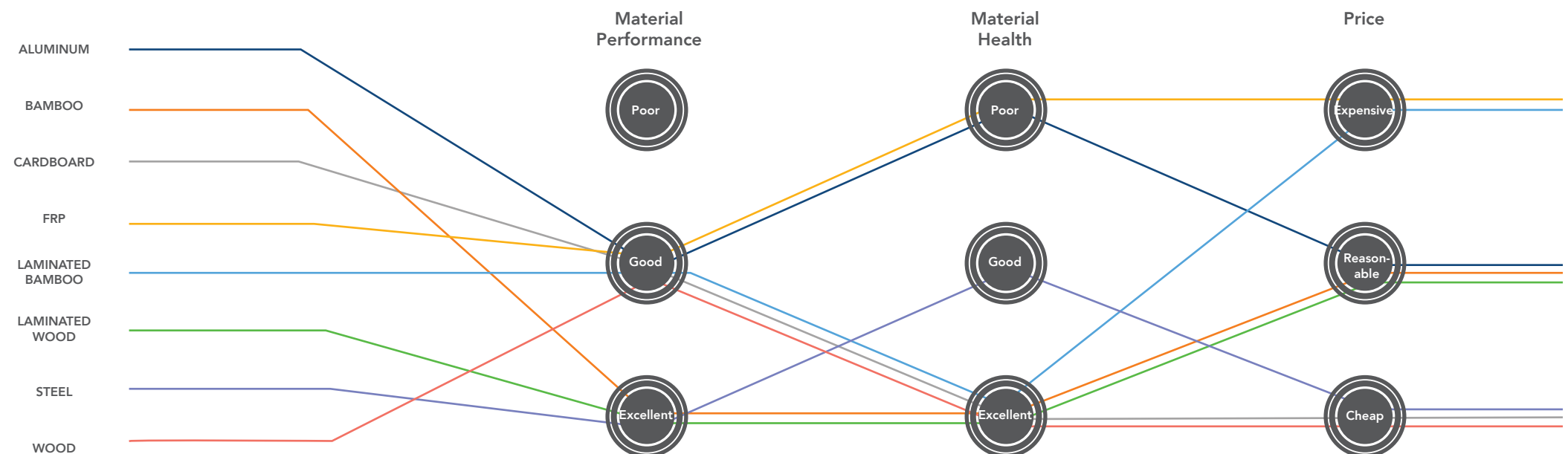

by author

7. Evaluation

After running the comparative analysis and streamlining the results, the material selection tool proved to be an invaluable method that can quickly aid the designer to visualize the results in order to select one material for a specific design. The goal was to create different possible what-if scenarios since each design will demand different performances in each of the selected criteria. This way, it is safe to assume that there is not one single material that outperformed all the others and that the ideal best material will depend on its application, availability, and budgetary constraints.

7.1 Results overall observations:

a) The chosen materials influenced the results. Since materials of the same category (metals & alloys, composite, natural and engineered) can perform differently, it was important to choose materials that are currently used in the construction industry or have great potential for expansion in the market. For example, some natural materials can be stronger than certain metals and alloys; fiber reinforced composites changed performance based on the ratio of fiber and resin, as well as the type of fiber (carbon, glass or natural fiber) and the orientation of the fibers; natural materials such as bamboo and wood changed performance based on the species; etc.

b) The type of parameters selected in each criterion influenced the results, given that materials may perform better in some categories while not in others. Therefore, it was important to choose the right types of categories that together would successfully generate meaningful results for the criteria in question. For example, a material could be much stronger than others but also have a much higher density. In that case, a weight-to-strength ratio was created as a separate parameter in order to analyze the two aspects at once.

c) The number of parameters in each criterion influenced the results. The more categories, the more detailed the results.

d) The point system influenced the results. Since materials were ranked based on best and worst performance, and not in real numeric values, the point system worked as a comparative analysis in a small sample of possible materials.

7.2 Results analytical observations:

Category 1: Metals & Alloys

a) **Steel**: had excellent structural performance the cheapest material since cost is per kilo of product. However, its good material health was a surprising result. The reason being so is that steel can be recycled and consumes less water to produce per kilo than a tree would need in order to grow in its lifetime, for example. However, its CO2 footprint and high embodied energy makes it a less sustainable option.

b) **Aluminum**: had good structural performance, poor material health and higher price than steel. This shows that most of the alternative materials that were analyzed would be a good replacement for the use of aluminum in structural applications.

Category 2: Composites

c) **FRP (Fiber Reinforced Composite)**: had good structural performance, poor material health and the most expensive of the analyzed materials. This shows that FRP is not the most viable option for temporary structures. While the material has great compressive strength, it also has a high density and a high cost, which justifies its use in other industries such as aerospace engineering, for example.

d) **Cardboard**: had good structural performance, excellent material health and cheap price. This shows that cardboard can be a good alternative for materials used in temporary structures. Other considerations need to be taken into account when using cardboard, such as durability and flammability.

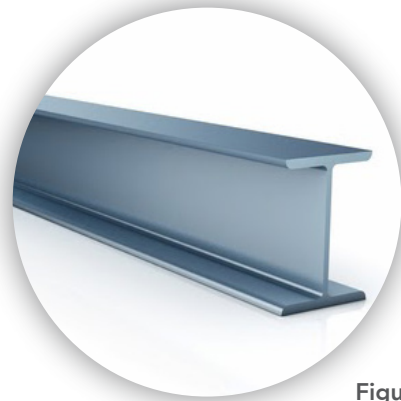

Figure 06

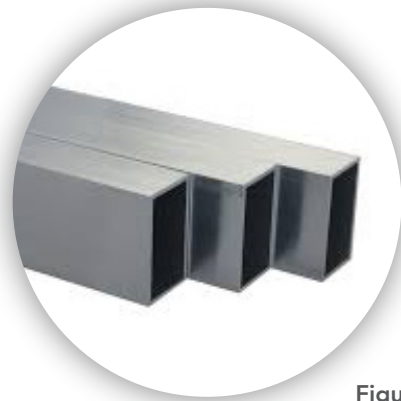

Figure 07

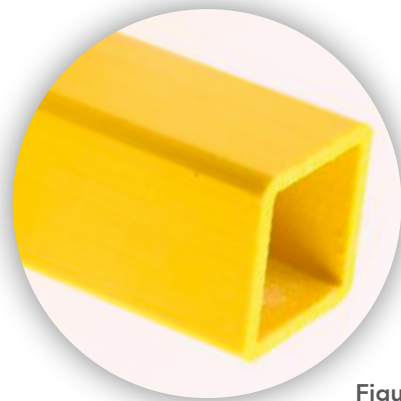

Figure 08



Figure 09



Figure 10



Figure 11



Figure 12



Figure 13

Category 3: Natural Materials

e) **Wood**: had good structural performance, excellent material health and cheap price. Surprisingly, the results for wood were similar to cardboard. However, by being a natural material, wood can offer a different range in performance depending on the species, as well as a variety of textures and appearance.

f) **Bamboo**: had excellent structural performance, excellent material health and reasonable price. This puts bamboo at the top ranking of alternative solutions for temporary structures. However, other factors need to be taken into account such as availability (usually bamboo is imported from Asia or South America) and maintenance.

Category 4: Engineered Materials

g) **Laminated Wood**: had excellent structural performance, excellent material health and reasonable price. Similar to the ranking of bamboo, laminated wood sits at the top ranking of alternative solutions for temporary structures. The type of species, wood treatment and lamination process can influence the performance of laminated wood. However, by being an engineered product, its quality is controlled before the material is used in construction. Also, maintenance is decreased while durability increases.

h) **Laminated Bamboo**: had good structural performance, excellent material health and expensive price. Laminated bamboo is a relatively new product that is very sustainable, but that it is still expensive in the market. But similar to laminated wood, it is an engineered product and, as such, its quality is controlled before the material is used in construction. Also, maintenance is decreased while durability increases.

PART 2: Materials Design Tool

1. Tool Description

Following the material selection tool in [Part 1](#), [Part 2](#) shows a few parameters that can be considered as guidelines for building sustainable & temporary structures that can be easily assembled and disassembled. In addition to choosing lightweight materials that have good structural performance and low environmental impact, designing for disassembly will require that the material is shaped in optimal dimensions for ease of handling and transportation. Additionally, connection methods will be key factor into making the whole disassembly process effective and efficient, minimizing time and cost.

In order to aid the designer to choose material sizes and connections that are appropriate for different designs, [Part 2](#) will:

- Give a brief overview of the different transportation methods and their sizes;
- Show weight limitations of handling material on site by manpower or lightweight machinery;
- Based on the limitations established above in terms of transportation efficiency and material handling, the 8 materials that were analysed in [Part 1](#) will be compared in [Part 2](#) in terms of span, deflection, weight and cost. For each material, a sectional profile was chosen from a given supplier in order to hypothetically illustrate a beam that can span up to 6m in the first case, or up to 12m in the second case. These sizes were obtained by the maximum material length for the different classes of transportation, as it will be established in the next section.
- Show different connections by categorizing them into different methods. In order to allow for easy assembly and disassembly, it is important to avoid adhesives, glue and nails as much as possible. The connections that will be illustrated will show pieces that can click, fit into each other or be easily attached (including bolted connections).

2. Sizes

2.1 Transportation as Boundary Condition

According to the European Modular System (Larson, 2009) there are three different classes of ground transportation:

- **Road Class I:** Vehicles of 7.82m in length that can carry up to 26ton;
- **Road Class II:** Vehicles of 13.6m in length in a single large module or two combined smaller modules of 7.82m in length. These vehicles can carry up to 40ton;
- **Road Class III:** Vehicles with one large (13.6m) and one small (7.82) module. These vehicles can carry up to 60ton.

This system allows for a combination of existing loading units – the modules – into longer and sometimes heavier vehicle combinations improving road freight transport efficiency and reducing environmental impact. Therefore, this system was chosen to illustrate the different sizes and load capacity of ground transportation vehicles.

As for transportation done by sea using shipping containers, the most typical sizes are 20ft (6.1m) and 40ft (12.2m) containers with slight difference in sizes depending on the manufacturer.

Typically, the smaller the unit, the smaller the transportation cost will be. Therefore, the transportation method was used as boundary conditions in order to determine the maximum sizes that can fit in each category. Whether the cargo is transported by sea or ground, it is easy to draw the connection between the sizes that would be optimal for the different classes:

- For **materials sizes up to 6m**, it can be transported (optimal) by: vehicle Road Class I or 20ft container
- For **materials sizes up to 12m**, it can be transported by: vehicle Road Class II or Class III or 40ft container

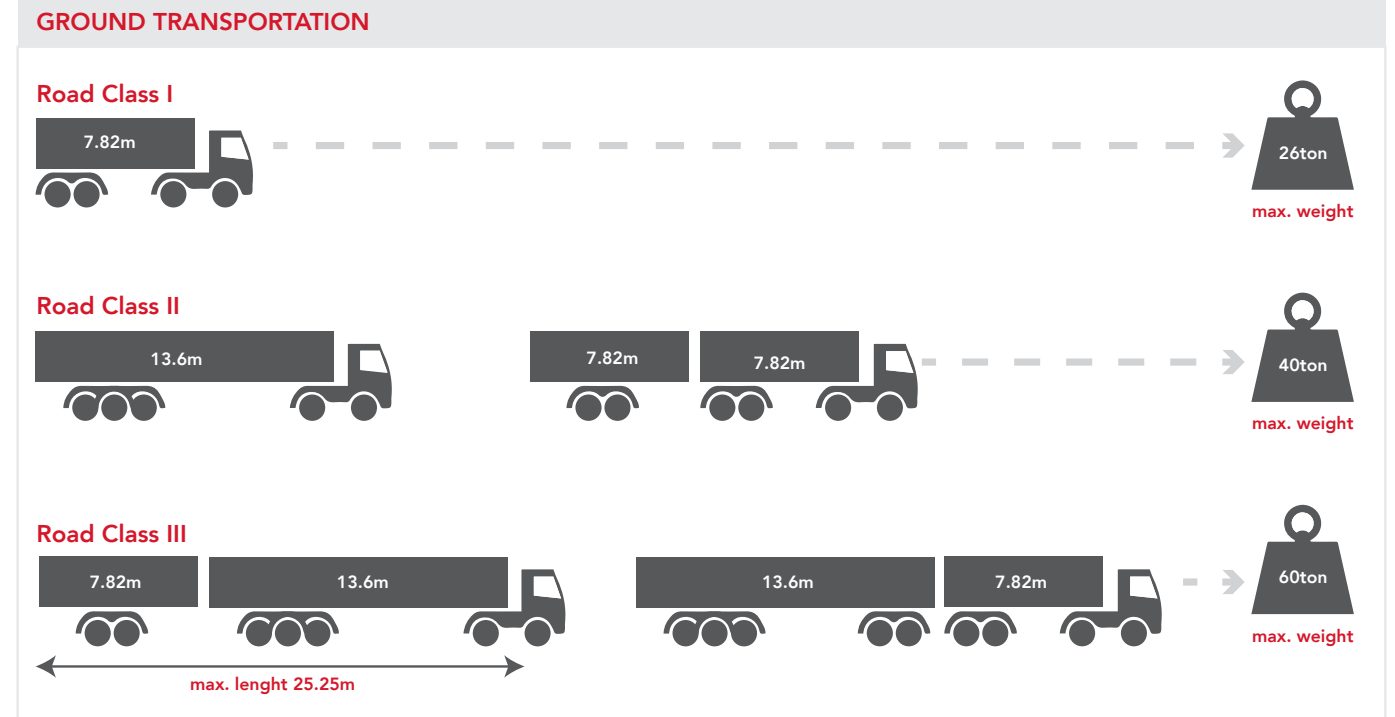

Source: Information based on the EMS (European Modular System) by ACEA. Diagrams by author

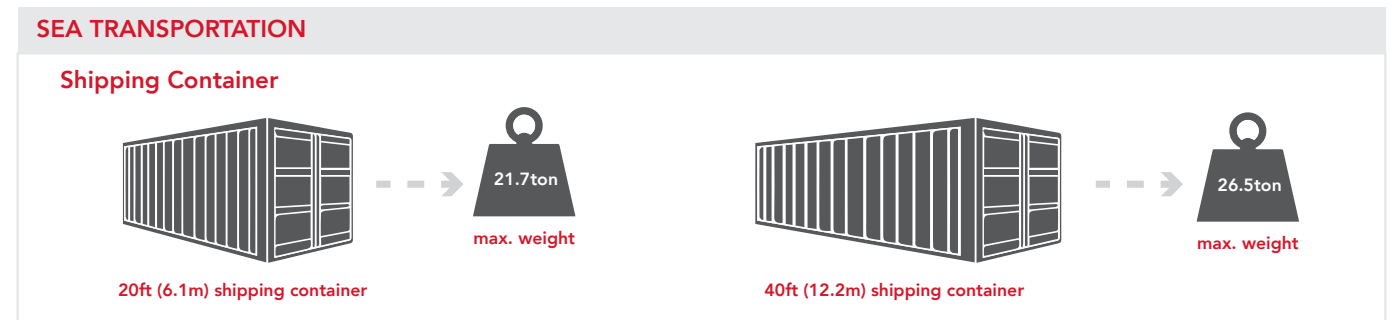

Source: Mainfreight, Global Supply Chain Logistics. Diagrams by author

by author

2.2 Handling on Site

After the material arrives on site and is unloaded, then the handling on site starts. In order to facilitate the assembly of the structure, it is important to know whether the material can be handled by manpower only, needs lightweight machinery, such as material lifts, or requires the assistance of motorized lifts such as forklifts and telehandlers.

For the assembly of lightweight structures, the simplest method would be to be able to lift and assemble all the material using manpower only. However, it is very common in practice to use manual material lifts to aid the builder or motorized lifts to accelerate the process and carry more load at once. Therefore, a brief overview is given below showing the uses and limitations of the three types of handling on site that is appropriate for lightweight structures: manpower, manual lift, motorized lift. The use of small or large cranes were not considered in this overview since it is more appropriate for heavier structures and is also very costly.

According to the Working Conditions Act mentioned in a publication by the Health Council of the Netherlands (2012), in order to prevent

health damage (to the back), the weight an employee can safely lift manually is between 5 kg and 23 kg, with 23 kg being applicable under the most optimal circumstances. Based on this information, a piece of up to 46kg can be safely carried by two construction workers with no compromise to their health.

For materials exceeding 46kg, a manual material lift proves to be an efficient method given that it can be easily transported to the site, can go through doors, have good maneuverability and can reach up to 7.9m in height and 363kg in weight.

For projects that require lifting of heavier pieces than a manual lift can handle or lifting multiple pieces at once, then a motorised lift such as forklift or telehandler is advisable. Most of these lifts, though, can only be used outdoors because of fuel combustion and needs ample space to maneuver.

On the right, the manual material lift and the telehandler information was obtained from Genie, which is a worldwide supplier and can be easily found in many countries.

HANDLING ON SITE

Category A



Category B

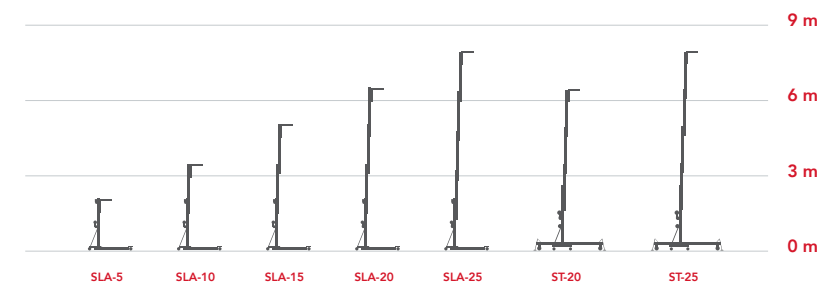

Source: Material Lifts by Genie

Category C

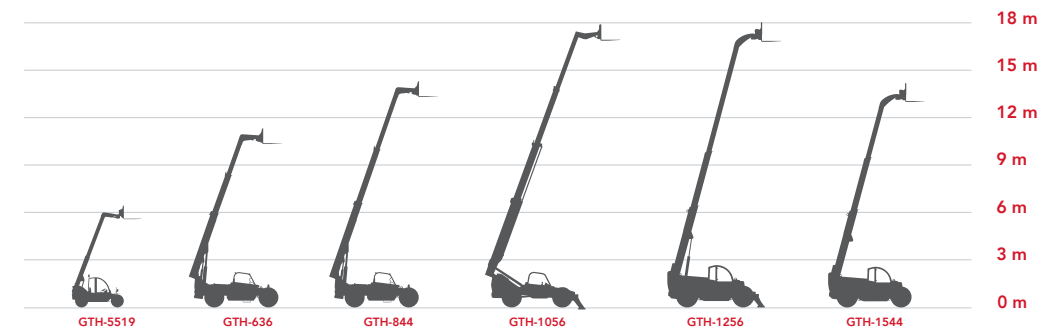

Source: Telehandlers by Genie

by author



Category A













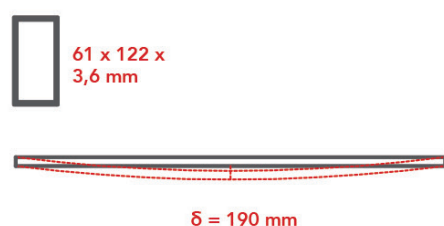

Category B

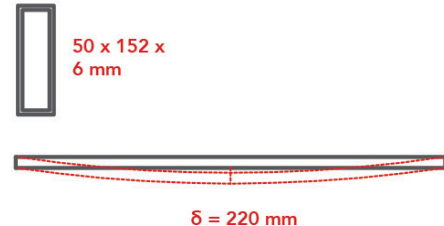



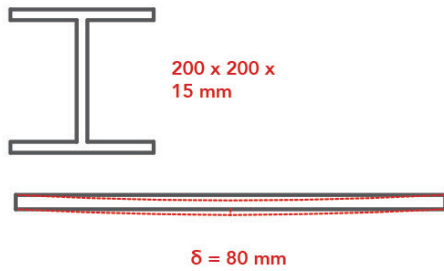
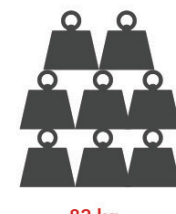

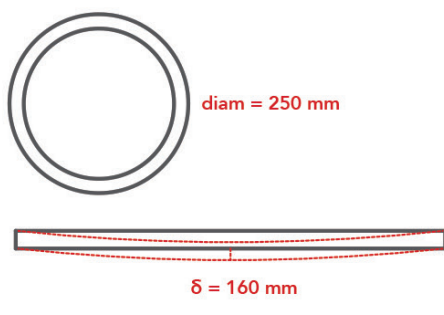





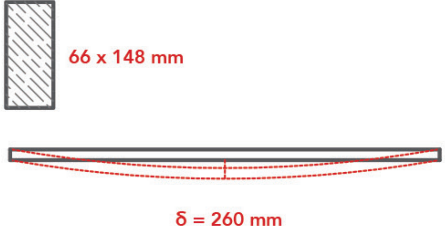

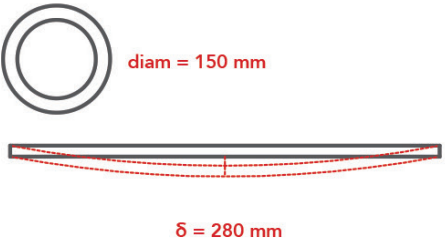

Category C

by author

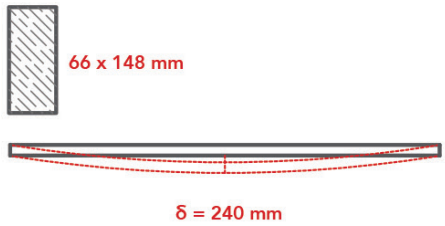
2.3 Beam Sizes and Sectional Profiles - up to 6m span



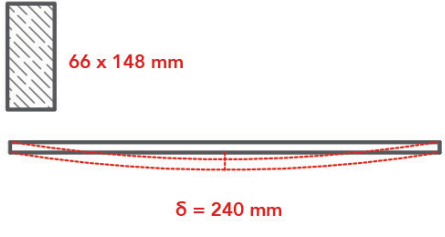







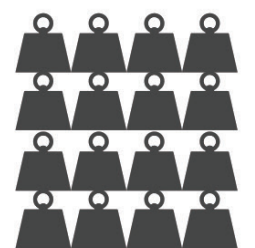

	Profile	Deflection	Weight	Cost
CATEGORY 1: METALS & ALLOYS	 <p>Steel</p>	 <p>61 x 122 x 3,6 mm $\delta = 190 \text{ mm}$</p>	 <p>30 kg</p>	 <p>20 €</p>
	 <p>Aluminum</p>	 <p>50 x 152 x 6 mm $\delta = 220 \text{ mm}$</p>	 <p>28 kg</p>	 <p>62 €</p>
	 <p>FRP</p>	 <p>200 x 200 x 15 mm $\delta = 80 \text{ mm}$</p>	 <p>82 kg</p>	 <p>2975 € x8,5</p>
	 <p>Cardboard</p>	 <p>diam = 250 mm $\delta = 160 \text{ mm}$</p>	 <p>30 kg</p>	 <p>29 €</p>

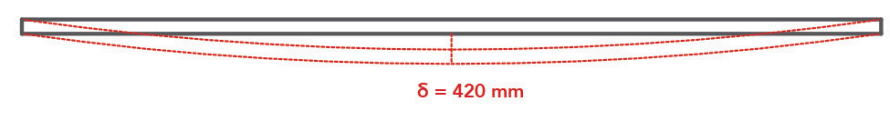
NOTE: Beam scale is 1/10 of sectional profile size
by author

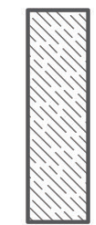
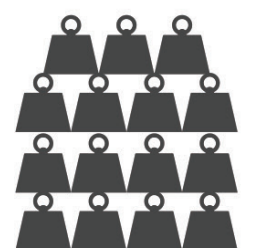
	Profile	Deflection	Weight	Cost
CATEGORY 3: NATURAL MATERIALS	 <p>Wood</p>	 <p>66 x 148 mm $\delta = 260 \text{ mm}$</p>	 <p>30 kg</p>	 <p>46 €</p>
	 <p>Bamboo</p>	 <p>diam = 150 mm $\delta = 280 \text{ mm}$</p>	 <p>17 kg</p>	 <p>43 €</p>
	 <p>Laminated Wood</p>	 <p>66 x 148 mm $\delta = 240 \text{ mm}$</p>	 <p>30 kg</p>	 <p>93 €</p>
	 <p>Laminated Bamboo</p>	 <p>66 x 148 mm $\delta = 240 \text{ mm}$</p>	 <p>40 kg</p>	 <p>404 €</p>

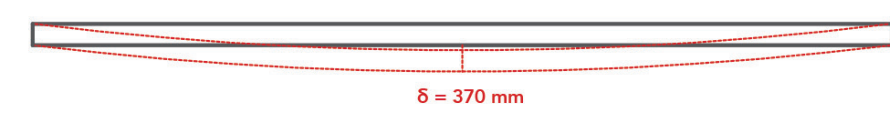
NOTE: Beam scale is 1/10 of sectional profile size
by author

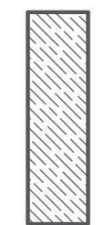
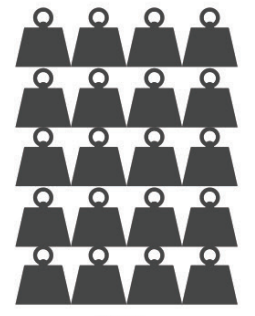
2.4 Beam Sizes and Sectional Profiles - up to 12m span

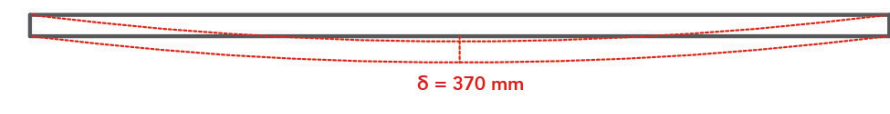
	Profile	Deflection	Weight	Cost
CATEGORY 1: METALS & ALLOYS	 <p>Steel</p>	 <p>100 x 200 x 6 mm</p>	 <p>166 kg</p>	 <p>111 €</p>
	 <p>$\delta = 420 \text{ mm}$</p>			
CATEGORY 4: ENGINEERED MATERIALS	 <p>Laminated Wood</p>	 <p>84 x 296 mm</p>	 <p>153 kg</p>	 <p>473 €</p>
	 <p>$\delta = 370 \text{ mm}$</p>			
	 <p>Laminated Bamboo</p>	 <p>84 x 296 mm</p>	 <p>204 kg</p>	 <p>2057 € x4,3</p>
 <p>$\delta = 370 \text{ mm}$</p>				
<p>NOTE: Beam scale is 1/10 of sectional profile size</p>				

by author

2.5 Beam Sizes and Sectional Profiles - Calculations

2.5.1 Calculations Methodology:

Based on the study done on section 2.1, which considered transportation sizes as boundary conditions, it was established that structural members up to 6m in length can be transported by vehicle Road Class I or 20ft container, while members bigger than 6m and up to 12m can be transported by vehicle Road Class II or Class III or 40ft container. Therefore the calculations took into consideration the maximum sizes that can be transported into each category (6m and 12m, respectively).

For each span, a load of 3KN/m was considered in accordance to EUROCODE 1 (Formichi, 2008) Class C5, which takes into account areas where people may congregate. The goal was to find the lightest and safest choice for the specified load in each material.

In order to find the optimal cross sectional profile for each material, several profiles were tested to verify if they passed the required section modulus: $S_x \text{ required} = M_{\text{max}}/\text{MoR}$ (10^{-3} m^3). The beams were designed for maximum moment: $M_{\text{max}} = W \cdot L^2/8$ (KN.m).

Suppliers were consulted in order to find the typical cross section profiles sizes in each material and 3 main categories were used for simplification:

a) Hollow rectangular profiles: aluminum and steel (FRP profiles had no suitable rectangular sections that could span 6m, therefore an H-beam was used instead;

b) Hollow round tubes: bamboo (natural shape) and cardboard;

c) Rectangular beams: laminated bamboo, laminated wood and wood

After determining the cross-sectional profiles that passed the required section modulus, the calculations allowed for find the deflection of each member and determine if it was below the maximum deflection allowed (used $L/200$), which was 0.30m for a 6m span and 0.6m for a 12m span.

For the sake of simplification, the calculations only took into account single members spanning the whole length. In reality, more complex designs can combine smaller members to reach large spans, such as trusses, etc.

For the second part of the calculations, when considering a 12m span, only a few materials could pass the required section modulus. Natural materials did not pass since they have a size limit that is proper of the material. Composite materials, such as FRP and cardboard also did not pass. Aluminum would pass if hollow rectangular profiles were bigger than 100 x 200 x 6mm, but such sizes were not found in any of the suppliers researched. Therefore, the only materials that could span in a single member more than 6m and up to 12m were: steel, laminated wood and laminated bamboo (custom order).

GOAL: find lightest and safest choice for a 3KN/m load for a determined span

$W = 3\text{KN/m}$ for Class C5 (areas where people may congregate). Source: Formichi, P. (2008). *EUROCODE 1, Actions on Building Structures*

FORMULAS:

1) Beam designed for maximum moment:

$$M_{\text{max}} = W \cdot L^2/8 \text{ (KN.m)}$$

2) Required Section Modulus

$$S_x \text{ required} = M_{\text{max}}/\text{MoR} \text{ (} 10^{-3} \text{ m}^3\text{)}$$

3) MoR is the Modulus of Rupture or bending strength and it depends on the material

4) Compute Section Modulus to check if member passes or fails the required Section Modulus

$$\text{Square/Rectangular beams: } S_x = b \cdot d^2/6 \text{ (} 10^{-3} \text{ m}^3\text{)}$$

$$\text{Other shapes: } S_x = I_{xx}/y \text{ (} 10^{-3} \text{ m}^3\text{)}$$

$$I_{xx} = \text{Moment of Inertia (} 10^{-3} \text{ m}^4\text{)}$$

$$y = \text{distance to neutral axis (m)}$$

5) Compare allowed deflections with the deflections of each member

$$\text{Deflection}_{\text{max}} = 5W \cdot L^4/384 \cdot E \cdot I_{xx} \quad E = \text{Young's Modulus (Gpa)}$$

$$I_{xx} = b \cdot h^3/12 \text{ (} 10^{-3} \text{ m}^4\text{)}$$

$$\text{Allowed deflection} = L/200 \text{ for roof beams} = 0.30\text{m (for span up to 6m)}$$

$$= 0.60\text{m (for span up to 12m)}$$

Source: BSI Standards Publication

6) Find the weight in kg of each member

$$\text{Mass} = \text{area profile} \cdot \text{lenght} \cdot \text{density}$$

7) Find the final price in Euros

$$\text{Final price} = \text{price/kg} \cdot \text{mass}$$

Units Reference:

$$\text{GPa} = 10^9 \text{ N/m}^2$$

$$\text{MPa} = 10^6 \text{ N/m}^2$$

$$\text{MPa} = 10^3 \text{ KN/m}^2$$

$$\text{KPa} = 10^3 \text{ N/m}^2$$

$$\text{Pa} = \text{N/m}^2$$

by author

2.5.2 Calculations Table

Table showing calculations based on 6m span:

Profile Type	Material2	Manufacture	sectional profile	Span (m)	W (KN/m)	Mmax = $W \times L^2 / 8$ (KN.m)	MoR (10^3 KN/m ²)	Sx required = M_{max} / MoR (10^3 m ³)	Beam b or diam. (m)	Beam d (m)	thickness (mm)	lxx (10^{-3} m ⁴)	Sx Beam 1 = $b \times d^2 / 6$ (10^{-3} m ³)	pass/fail	Area (10^{-3} m ²)	Volume m ³	Density (kg/m ³)	Mass (kg)	Price EUR/kg	Final Price EUR	Young's Modulus MoE (Gpa)	Deflection (m)
1	Aluminum	Extrusion	hollow retan. (Boal)	6	3	13,5	241	0,0560	0,05	0,152	6	0,00322	0,0644	Pass	1,764	0,010584	2700	28,58	2,17	62,01	71	0,22
1	FRP	Pultrusion	H-beam (Fibrolux).	6	3	13,5	46,4	0,2909	0,2	0,2	15	0,068	0,3400	Pass	8,75	0,0525	1565	82,16	36,2	2974,28	9	0,08 *
1	Steel	welded	hollow retan. (TATA Steel)	6	3	13,5	690	0,0196	0,061	0,122	3,6	0,00129	0,0211	Pass	0,645	0,00387	7850	30,38	0,67	20,35	207	0,19
2	Bamboo	natural	hollow tubes (Guadua Bamboo)	6	3	13,5	120	0,1125	0,15		20	0,01	0,1333	Pass	4,398	0,026388	666	17,57	2,48	43,50	18	0,28 **
2	Cardboard	laminated	hollow tubes	6	3	13,5	35	0,3857	0,25		20	0,0543	0,4344	Pass	7,539	0,045234	670	30,31	0,985	29,85	6	0,16
3	Bamboo	laminated	retangular beams (Moso)	6	3	13,5	80	0,1688	0,066	0,148		0,018	0,2409	Pass	9,768	0,058608	686	40,21	10,05	404,06	12	0,24
3	Wood	laminated	retangular beams (Accoya)	6	3	13,5	81	0,1667	0,066	0,148		0,018	0,2409	Pass	9,768	0,058608	515	30,18	3,1	93,57	12	0,24
3	Wood	natural	retangular beams (Radiata Pine)	6	3	13,5	81	0,1667	0,066	0,148		0,018	0,2409	Pass	9,768	0,058608	515	30,18	1,53	46,18	11	0,26 ***

* smaller rectangular profile 200x100x8mm from Fibrolux did not pass and largest rectangular profile 500x200x10mm was too big.

** used Guadua Bamboo price from Bamboo Import Europe.

*** profile 50x150mm causes a 0.33m deflection, which is bigger than the allowed deflection (0.30m).

by author

Table showing calculations based on 12m span:

Profile Type	Material2	Manufacture	sectional profile	Span (m)	W (KN/m)	Mmax = $W \times L^2 / 8$ (KN.m)	MoR (10^3 KN/m ²)	Sx required = M_{max} / MoR (10^3 m ³)	Beam b or diam. (m)	Beam d (m)	thickness (mm)	lxx (10^{-3} m ⁴)	Sx Beam 1 = $b \times d^2 / 6$ (10^{-3} m ³)	pass/fail	Area (10^{-3} m ²)	Volume m ³	Density (kg/m ³)	Mass (kg)	Price EUR/kg	Final Price EUR	Young's Modulus MoE (Gpa)	Deflection (m)
1	Aluminum	extrusion	hollow retan. (Boal)	12	3	54	241	0,2241	0,05	0,152	6	0,00322	0,0644	Fail	1,764	0,021168	2700	57,15	2,17	124,02	71	3,54 *
1	Steel	welded	hollow retan. (TATA Steel)	12	3	54	690	0,0783	0,1	0,2	6	0,0094	0,0940	Pass	1,764	0,021168	7850	166,17	0,67	111,33	207	0,42
3	Bamboo	laminated	retangular beams (Moso)	12	3	54	80	0,6750	0,084	0,296		0,182	1,2266	Pass	24,864	0,298368	686	204,68	10,05	2057,04	12	0,37
3	Wood	laminated	retangular beams (Accoya)	12	3	54	81	0,6667	0,084	0,296		0,182	1,2266	Pass	24,864	0,298368	515	153,66	3,1	476,34	12	0,37

* manufacturers that were researched did not produce hollow rectangular aluminum profiles bigger than 152x50x6mm

by author

NOTE: Values in red were obtained from Part 1 of this design manual

3. Connections

The following list is a simplification of possible connections that can be used to facilitate assembly and disassembly of lightweight temporary structures. The classification below is not a scientific one, but simply a method that tries to showcase the different possibilities in a categorized way. As a rule of thumb, the fewer the number of connections and elements to join, the faster the assembly time will be.

3.1 CONNECTIONS USING THE SAME MATERIAL AS STRUCTURE

Clamped Connections

Connections that use a clamp or ring as a means to attach multiple elements.



Slotted Connections

Connections that allow elements to fit into each other by means of a slot or tenon.



Fitting Connections

Connections that allow elements to fit into each other by means of laps that are similar in size and shape.

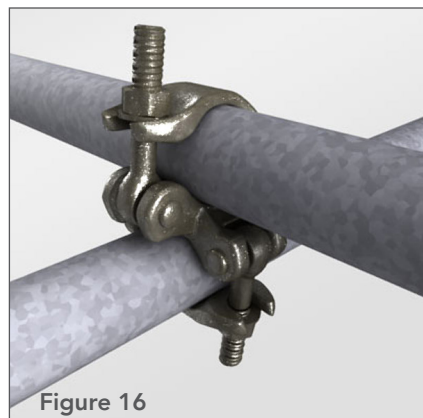
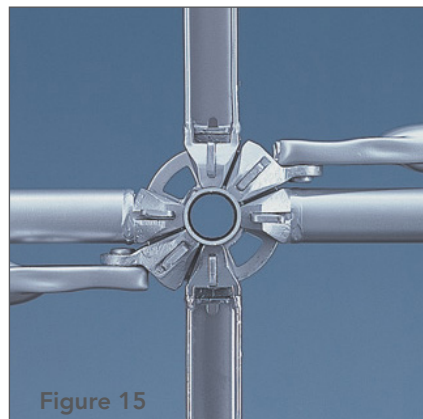

3.2 CONNECTIONS USING DIFFERENT MATERIAL FROM STRUCTURE

Fastened Connections

Connections that allow different elements to be fastened to each other by the use of fittings, ties or rope.

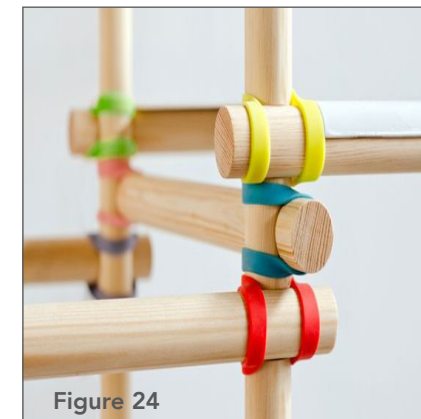

Inserted Connections

Connections that link different elements by inserting them into it.

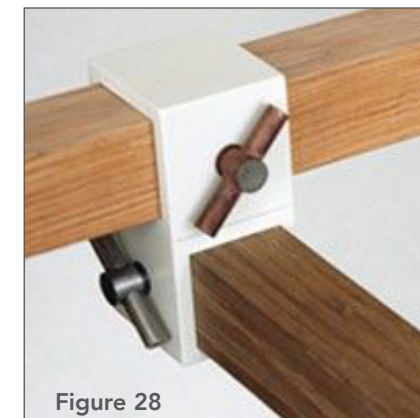

Bolted Connections

Connections that have different elements such as steel plates that are bolted to the members.

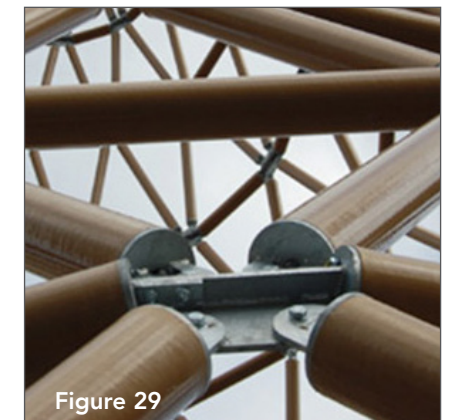

PART 3: Case Studies

1. FRP (Fiber Reinforced Polymer)

BIG Serpentine Pavillion

The Serpentine Pavillion 2016 was created by Bjarke Ingels Group (BIG) and featured two walls made of white "bricks" in fiber reinforced composite. According to a statement released by the architects, they attempted to design a structure that was free-form yet made of modular pieces, which were identical boxes that were shifted in order to create the fluid looking structure.

The project has been described as the "unzipped wall", which forms a space where the two walls come apart housing the program.

The translucency of the fiberglass boxes creates a play of light and shadow in the interior. The boxes were created using pultruded profiles.





Figure 35

2. Bamboo & Laminated Bamboo

German-Chinese House at Expo Shanghai

The “German-Chinese House” at the Shanghai World Expo 2010 was designed by Markus Heinsdorff, who is a designer and installation artist famous for building with natural and high-tech materials. The structure of the building was constructed using giant bamboo poles of 8m in height and was treated for fire resistance. In the interior, glue laminated bamboo elements were used instead of raw bamboo. The glue laminated beams span 6m and create a self-supporting room on the upper floor.

The connecting joints were made of steel to hold together the bamboo supporting frame structure. The roof membrane was a special PVC, while the façade used translucent ETFE films. The building was designed to be disassembled and its parts fully reused or recycled. It is a hall of 25 x 10m housing exhibition, game and conference areas. Similar to the connections, the furniture was also custom-made and designed using bamboo which intended to demonstrate the versatility of the renewable raw material.

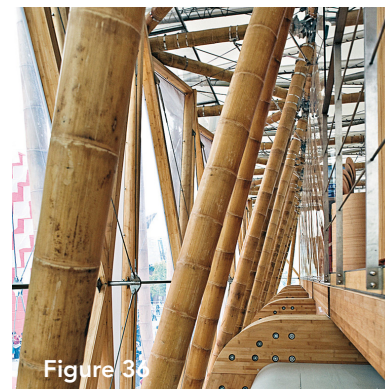

Figure 36



Figure 37

3. Cardboard & Laminated Wood

Japanese Pavilion at EXPO Hanover

The Japanese Pavillion for Expo 2000 in Hannover, Germany was designed by Shigeru Ban architects in collaboration with Frei Otto and Buro Happold engineers. Since the theme of the expo was sustainability, the team decided to create a pavilion using recycled materials that could be dismantled and used again. The structure was a cable-tensioned cardboard construction in honeycomb shape. The envelope of the pavilion consisted of a waterproof paper membrane. However, due to fire safety issues it was replaced with a PVC membrane.

The pavilion was 72m long, 35m wide and 15m high and took three weeks to assemble and three years to design. One of the goals of the design was to use low-tech methods. Therefore, the joints were called simple cloth or metal tape. At the intersection of two paper tubes, a three-dimensional network was created by staggering the tubes forming a honeycomb structure that was supported with tape. The structure was very challenging and had many troubles to obtain permits with the German authorities, needing wood structural reinforcement for approval. Nonetheless it brought paper architecture to a status never achieved until then.

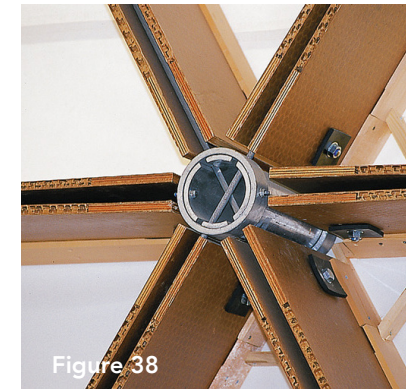

Figure 38



Figure 39



Figure 40

PART 4: Qualitative Analysis of a selected material

1. Material Selection Parameters

During **Part 1** of this Design Manual, a material selection tool helped to visualize how different materials perform in relation to three main criteria: material performance, material health and cost. The results pointed out to different possible what-if scenarios. In the case of designing a sustainable and lightweight temporary structure, a few materials stood out: laminated wood and natural bamboo, which both achieved excellent structural performance, excellent material health and reasonable price.

During **Part 2** of this Design Manual, different sectional profiles were tested in order to achieve spans of different sizes. For each option, the weight and the price of the members were calculated. During this analysis, only 3 materials proved feasible to be used as a single member that could achieve spans larger than 6 meters, namely: steel, laminated wood and laminated bamboo.

Therefore, while comparing the results of **Part 1** and **Part 2**, I chose to do a qualitative analysis of the material that have proven to be both viable in terms of overall performance and flexible in terms of sizes: laminated wood. More so, laminated wood offers different types of lamination techniques that can be tailored to a specific performance. Additionally, I chose to further study an innovative type of wood treatment technique, called acetylation, and how it can further enhance the quality of the wood that can be used for structural purposes.

2. Sustainability

2.1 Why acetylated wood?

Despite all the environmental problems and vast generation of waste, the focus of the construction industry still seems to be on the use of non-renewable resources such as plastics, concrete and metals, as well as of endangered materials such as tropical hardwoods.

While there are initiatives to close the loop in the technical cycle of the above-mentioned materials by recycling them, more energy is needed in the process. Moreover, these initiatives are far more scarce than the actual production of these materials and the waste that they generate.

In the construction industry in Europe, the use of wood only accounts for 1.6% of material use according to a study conducted by Ecorys (2014). While natural and untreated wood can pose some challenges that hinders its use in construction, such as inconsistent quality, poor durability and instability; new engineered wood techniques are coming to the surface in order to enhance its quality and performance.

During one of my interviews I had the opportunity to visit the manufacturing plant and world distribution center of Accoya wood, located in Arnhem in The Netherlands. In the visit, I imagined I was going to learn about wood lamination processes and product types, but I learned much more than that. For my surprise, Accoya does not produce the end product such as lumber, decking, plywood and furniture; instead, it treats the wood in a process that it naturally enables it to become more durable, impermeable, not as susceptible to rot and termites in a process is called acetylation.

2.2 Manufacturing

The acetylation process consists of impregnating the wood in vinegar in order to replace the free -OH (hydroxyl) groups within the cell with acetyl groups, which are hydrophobic preventing water bondage and consequent swelling of the wood. This process changes the wood not on the surface, like most treatments used today, but it modifies it in its core enhancing the wood's structural performance and durability while also creating by-products that can be used for different purposes.

Since the acetylation process is non-toxic and only enhances the amount of acetyl in the wood, it enables the treated wood to be disposed of in exactly the same way as untreated wood. Also, given that it does not decay as much as most of the wood, the treated wood can be re-used in other projects as the material has the enhanced quality that enables a longer lifespan.

2.3 Products & by-products

Also, it was very interesting to learn that the whole process takes into account different material streams that create not only quality products, but also by-products. While the vinegar utilized in the process is cleaned and sold in the food sector, the Accoya wood that has defects are not put to waste. Instead, it is transformed into chips, sent to Ireland and then transformed into particle boards known as Tricoya (Veerlan K., interview, December 2nd, 2016).

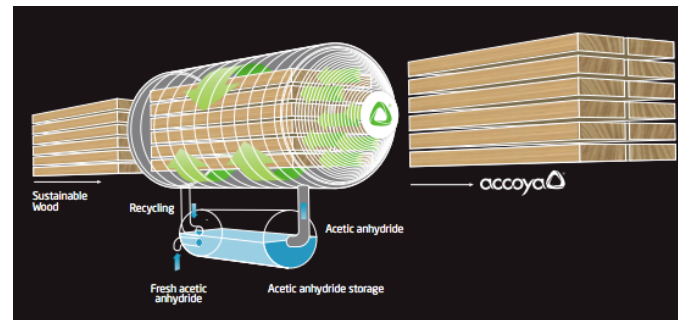
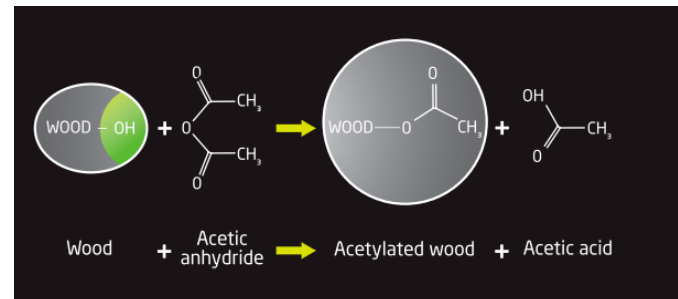
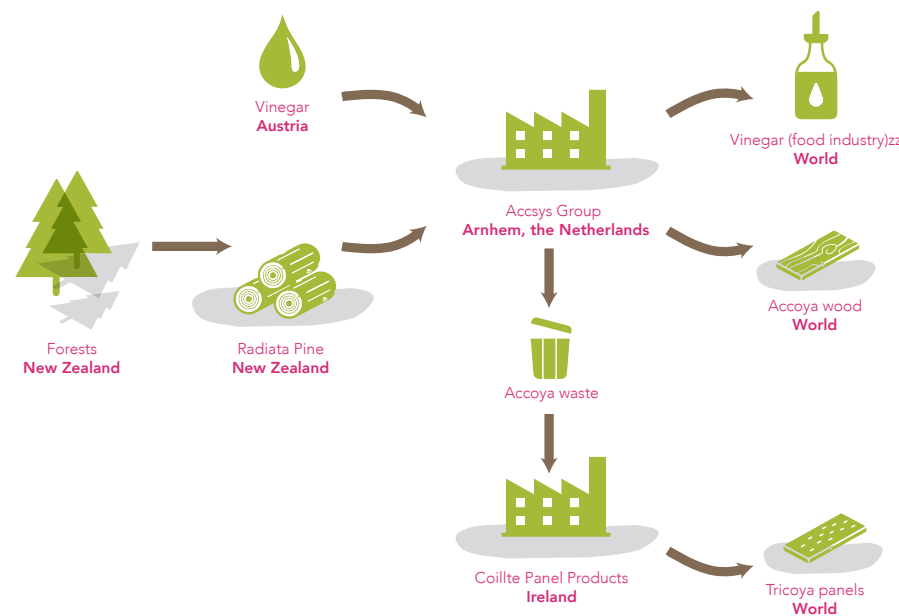

Figure 41, 42 & 43 - Acetylation Process
Source: All images by Accoya



At the end-of-life phase Accoya wood and Tricoya panels can be fully reusable and recyclable. Reuse is recommended but they may be safely incinerated for bioenergy or composted to close the loop of the carbon cycle.

Diagram showing products and by-products of the acetylation process.
Source: by author based on interview

3. Enhanced Quality

3.1 Knot-free timber

The acetylation process used by Accoya uses the wood species Radiata Pine, which is a softwood that is native to the central coast of California but is widely planted in Australia and New Zealand. The wood is easy to work and it readily accepts preservatives. Other wood species are in phase of testing using Beech (Fagus). The forests that exports Radiata Pine to the Netherlands are located in New Zealand. A rigorous forestry program is in place to ensure that these forests are managed sustainably. Also, due to high quality control the young trees are pruned one to three times and the lower branches are removed when they are young to produce knot-free timber. For architectural applications, the designer can choose the textures and percentage of knots in the timber.

3.2 Aesthetics

In its natural form, Accoya wood is cream/light straw color. However, the wood can receive different coatings and finishes, and those will last at least twice as long as on unmodified woods. Also, acetylated wood resists better to UV degradation, termites, and decay, which will keep the natural beauty of the wood for longer.

3.3 Dimensional Stability

The acetylation process changes the moisture content of the timber to less than 8%. Also, by modifying its core the timber becomes hydrophobic, reducing swelling and shrinkage by 70 to 80%. This enhances dimensional stability of the wood to a better performance than tropical hardwoods (Accoya, 2016b).



Figure 44 - Accoya wood. Source: Accoya

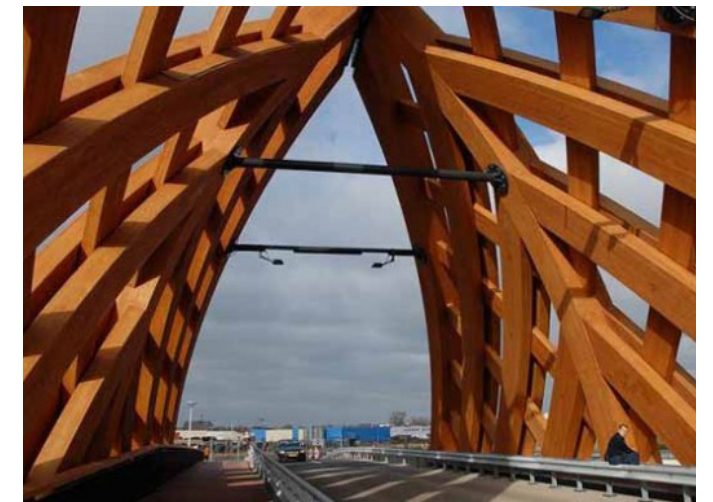

Figure 45 - Sneek Bridge in The Netherlands.
Source: inhabitat.com

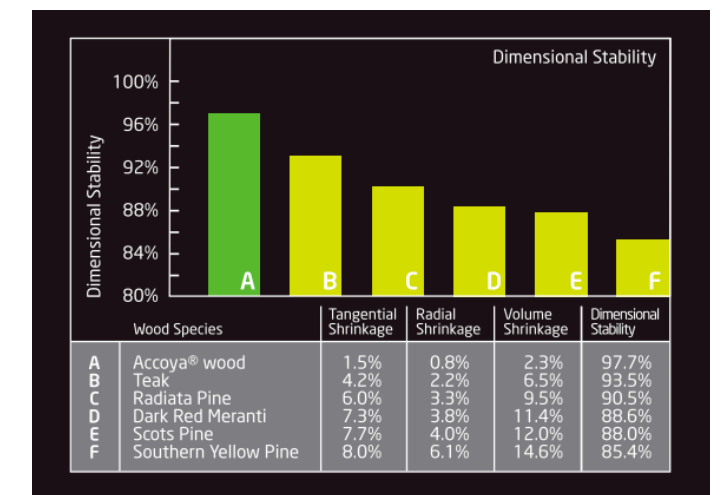

Figure 46 - Dimensional Stability. Source: Graph by Accoya

4. Enhanced Performance

4.1 Durability

The acetylation process, which is a “natural” but induced transformation, changes the wood durability from Class 4 to Class 1 (BS EN 350-2 classification), which is the highest performance rating for timber and indicates that it can achieve a 60-year service life in ground contact or 25 years in contact with fresh water. This way, the acetylated wood has a durability comparable to the most durable wood species. According to tests conducted by the SHR institute in the Netherlands (Accoya, 2016c), acetylated wood showed minimal signs of rot, decay and fungal damage after 20 years of exposure to water. Hence, it is widely used in projects that have close contact with water. Also, acetylated wood is indigestible to a wide range of insects, which creates an effective barrier to their attack. All these factors increase the durability of the wood and it minimizes its need for maintenance.

4.2 Structural Performance Enhancement

In addition to enhancing the performance of the wood by naturally modifying it through the acetylation process, laminating it will make the wood even stronger for structural applications. Below, a comparison is made between untreated wood, acetylated wood and laminated acetylated wood.

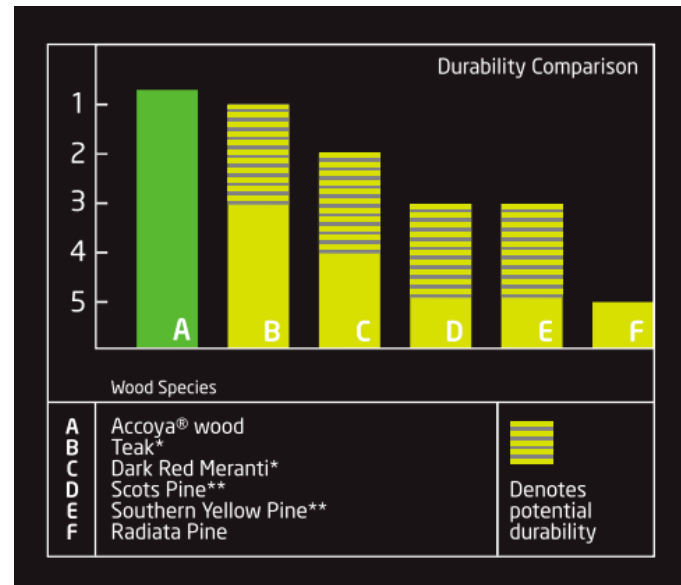

Figure 47 - Durability Graph. Source: Graph



1) 15 year canal lining test 2) 10 year external coating test

Figure 48 & 49. Durability Tests. Source: Images by Accoya



Figure 50 - Moses Bridge in The Netherlands
Source: feel-planet.com

Structural Performance Enhancement

Performance	untreated wood	acetylated wood	acetylated & laminated wood
Durability	Class 4	Class 1	Class 1 *
Quality	variable	consistent	consistent
Density	100%	110%	110% **
Flexural Strength (MoR)	100%	120%	120% ***
Strength-to-weight ratio	100%	108%	108%
Young's Modulus (MoE)	100%	90%	105% ****
Compressive Strength	100%	100%	114% *****
Tensile Strength	100%	100%	137% *****

by author

* Classification presented in BS-EN 350-2
Class 1 - very durable
Class 2 - durable
Class 3 - moderately durable
Class 4 - slightly durable
Class 5 - not durable

** some sources say that density increases during acetylation process due to vinegar, while others consider density increase irrelevant.

*** 20% increase between untreated wood and acetylated wood based on Accoya performance report. Source: Accoya, 2016c
Laminated Accoya wood is stronger in bending than solid Accoya wood but structural report shows same numbers. Source: Accoya, 2016b

**** 10% decrease between untreated wood and acetylated wood based on Accoya performance report. Source: Accoya, 2016c

***** Information based on Accoya structural report. Source: Accoya, 2016b

5. Lessons Learned

Even though this Design Manual focus on acetylated wood, acetylation, however, is not the only process by which wood can be naturally enhanced. A Norwegian company called Kebony has recently developed a process called kebonization, which impregnates the wood with ‘biowastes’ in order to also modify the wood from its core. The result is similar to Accoya with enhanced quality and durability but, instead, the process uses furfuryl alcohol, which is produced from agricultural crop waste from corn and sugarcane, for example. Similar to the acetylation process, it strengthens the internal cell structure of the timber, augmenting its mechanical properties. However, kebonization deepens the color of the wood resulting in darker brown and grey tones.

This learning experience was very eye-opening to me since I could understand that wood can be transformed into high quality and durable product by a process that is ‘natural’. More so, it brings it to a level that it can replace other more commonly used construction materials such as aggregates and steel. Also, this process will hopefully enable to reduce the number of imports of tropical timber, which is considered high quality wood, enabling the importing nations, such as the Netherlands, to become less dependent on the imports and more self-reliant and self-sufficient on what it can produce in-house.

Conclusion

In the construction industry, the materials that are most commonly used such as steel, aluminum, concrete and aggregates produce the most amount of demolition waste, accounting for nearly 30% of the total waste generated in Europe. Likewise, the same materials are responsible for the majority of the embodied energy in building materials (Ecorys, 2014). Therefore, it is imperative that the building sector seeks new materials and techniques to build with in order to offset the use of these materials and minimize the waste produced at the end of the chain. So, it becomes the role of the designer to understand the impact of the materials that they are using and to look out for alternative solutions that will consider sustainability from the beginning of the chain, sourcing innovative or low-impact materials that can offset demolition waste and have lower embodied energy.

Since this guide was focused on sustainable and lightweight temporary structures, it compared the performance of various alternative materials to those of steel and aluminum, which are largely used in temporary architecture. The criteria utilized to draw comparison were: lightness, structural performance, material health and cost.

Additionally, material member sizes and weight were computed for a hypothetical span in order to aid designers make a safe choice depending on the application. Also, possible connections were showcased in order to facilitate easy assemble and disassemble.

In short, the goals of this manual were:

- a) Bring awareness to the importance of choosing the right materials and knowing their impact;
- b) Aid designers to draw quick comparisons between the different materials;
- c) Help them choose possible sizes and connections for their design.
- d) Understand how new techniques can implement an ordinary material in order to extend its lifespan and possibility for re-use.

This Design Manual, however, only scratched the surface of such a vast realm of material possibilities, sizes and connections. Further research would help to expand on different uses and construction techniques. Then, maybe in the future, this knowledge can be transferred to the construction industry as a whole and not solely used for the creation of temporary architecture.

Literature

- Accoya (2016a). *Sustainability Guide*. Retrieved from https://www.accoya.com/wp-content/uploads/2016/07/SB_EN_lowres.pdf
- Accoya (2016b). *Structural Design Guide to Eurocode 5*. Retrieved from https://www.trada.co.uk/jail/downloads/dir/memberBrochures/57E7D971-9DD7-4784-92FA-95DE9D49D63C/DG_lowres.pdf
- Accoya(2016c). *Performance Test Summary*. Retrieved from https://www.accoya.com/wp-content/uploads/2016/09/Accoya_Performance_EN.pdf
- Barton, G. (2013). *Post Pop-Up Architecture: Do All Buildings Have Lifespans?* Retrieved from <http://architizer.com/blog/unbuildings/>
- Brownell, B. (2012). *Material strategies : Innovative applications in architecture (Architecture briefs)*. New York: Princeton Architectural Press.
- BSI Standards Publication (2005). *UK National Annex to Eurocode 3: Design of Steel Structures*. Retrieved from <https://law.resource.org/pub/uk/ibr/bs.na.en.1993.1.1.2005.pdf>
- Cobb, F. (2015). *Structural engineer's pocket book : Eurocodes (Third edition.)*. Boca Raton: CRC Press. http://public.eblib.com/choice/publicfullrecord.aspx?p=1619942_0
- Ecorys (2014). *Resource efficiency in the building sector*. Retrieved from <http://ec.europa.eu/environment/>
- Ellen Macarthur Foundation (2013). *Towards the circular economy*. Retrieved from <https://www.ellenmacarthurfoundation.org/assets/downloads/publications/Ellen-MacArthur-Foundation-Towards-the-Circular-Economy-vol.1.pdf>
- European Commission. (2016). *Construction and Demolition Waste*. Retrieved from: http://ec.europa.eu/environment/waste/construction_demolition.htm
- Formichi, P. (2008). *Eurocode 1 Actions on Building Structures*. Retrieved from http://eurocodes.jrc.ec.europa.eu/doc/Moscow08/Moscow08_9_Formichi.pdf
- Genie (2016a). *Material Lifts*. Retrieved from: <http://www.genielift.com/en/products/material-lifts/>
- Genie (2016b). *Material Lifts*. Retrieved from: <http://www.genielift.com/en/products/telehandlers/>
- Health Council of the Netherlands (2012). *Manual lifting during work*. Retrieved from https://www.gezondheidsraad.nl/sites/default/files/2136E_Manual_Lifting_during_work.pdf
- Illston, J. M., & Domone, P. L. J. (2001). *Construction materials : Their nature and behaviour* (3rd ed.). London: Spon. <http://www.crcnetbase.com/isbn/9780419258506>
- König, H. K. N. L. T. (2010). *A life cycle approach to buildings*. Retrieved from <http://www.ebrary.com>
- Kronenburg, R. (2013). *Architecture in Motion*. Taylor and Francis. Retrieved from <http://www.ebrary.com>
- Lane, T. (2007). *Our dark materials*. *Building Design*, 45. Retrieved from <http://www.bdonline.co.uk/our-dark-materials/3099435.article>
- Larsson, S. (2009). *Weight and dimensions of heavy commercial vehicles as established by Directive 96/53/EC and the European Modular System (EMS)*. Retrieved from <http://www.acea.be>
- Sharma, B., Gattoo, A., Bock, M., & Ramage, M. (2015). Engineered bamboo for structural applications. *Construction and Building Materials*, 81, 66–73. Retrieved from <http://dx.doi.org/10.1016/j.conbuildmat.2015.01.077>
- Sullivan, C. (2016). *Sustainable Envelopes with Structural Engineered Bamboo*. Retrieved from <https://continuingeducation.bnppmedia.com/coursePrint.php?L=517&C=1548>
- Teara. *Life cycle of a managed radiata pine*. Retrieved from <http://www.teara.govt.nz/en/diagram/16836/life-cycle-of-a-managed-radiata-pine>
- Veerlan, K., interview, December 2nd, 2016 (see appendix)
- Vroege, G-J. (2016). *Circular Economy basics* (Lecture on November 30, 2016). The Hague: SGS Search
- Watson, F. V. S. L. W. (2015). *Pavilions, Pop Ups and Parasols*. Retrieved from <http://www.ebrary.com>
- Wood Solutions. *Pinus radiata*. Retrieved from <http://www.woodsolutions.com.au/Wood-Species/Radiata-Pine>
- World Economic Forum. *From linear to circular – accelerating a proven concept*. Retrieved from <http://reports.weforum.org/toward-the-circular-economy-accelerating-the-scale-up-across-global-supply-chains/from-linear-to-circular-accelerating-a-proven-concept/>
- Suppliers (Part 2 Calculations):
- Fibrolux GmbH (2016). *Reinforced Plastics*. Retrieved from <http://fibrolux.com/>
- Bamboo Import Europe. *Guadua Bamboo Poles*. Retrieved from <https://www.bambooimport.com/en/guadua-bamboo-pole-o-14-15-x-300-cm>
- Kebody (2016). *What is Kebody?*. Retrieved from <http://kebody.com/en>
- Industrial Metal Supply Co. *Aluminum Rectangle Tube*. Retrieved from <https://www.industrialmetalsupply.com/-aluminum-rectangle-tube>
- Tata Steel. *RectangularHollowSections*. Retrieved from <http://www.hitechoverseas.com/images/distributors-dealers-india/Tata-Steel-Rectangular-Hollow-Sections-big.jpg>
- Boal Aluminium. *Rectangular Profiles*. Retrieved from <http://www.boal.nl/uploads/files/Rechthoekig%20profiel.pdf>
- Calculation tools:
- <https://skyciv.com/moment-of-inertia/>
- <http://www.amesweb.info/SectionalPropertiesTabs/SectionalPropertiesIbeam.aspx>

Appendix

Appendix 1 - List of Figures

PART 1 - INTRODUCTION

Figure 01 - Embodied Energy Analysis.
Source: <http://www.bdonline.co.uk/>

Figure 02 - Four Principles for Circular Economy
Source: Ellen MacArthur Foundation

Figure 03 -Material Universe before boundary conditions
Source: CES Edupack (author's analysis)

Figure 04 - Density x Flexural Strength boundary conditions
Source: CES Edupack (author's analysis)

Figure 05 - Density x Embodied energy boundary conditions
Source: CES Edupack (author's analysis)

PART 1 - MATERIALS

Figure 06 - Steel I-Beam
Source: www.steel-beam-calculations.co.uk

Figure 07 - Rectangular Piping
Source: <http://www.migoldline.com/>

Figure 08 - Composite profile
Source: bpress.cn

Figure 09 - Cardboard Tube
Source: crafthubs.com

Figure 10 - Wood Beam

Figure 11 - Guadua Bamboo Pole
Source: Bamboo Import Europe

Figure 12 - Glue laminated beam
Source: archiexpo.com

Figure 13 - Laminated Bamboo
Source: bamboo.ie/lumber

PART 2 - CONNECTIONS

Figure 14 - ring lock scaffolding
Source: <http://dss.net/ring-lock-scaffold/>

Figure 15 - ring lock scaffolding
Source: <http://dss.net/ring-lock-scaffold/>

Figure 16 - Scaffolding swivel clamp

Figure 17 - The Ban Table by Shigeru Ban
Source: <http://gizmodo.com/>

Figure 18 - mortise and tenon
Source: <http://www.lukaspeet.com/Village-Side-Table-2012>

Figure 19 - mortise and tenon joint
Source: <http://redwoodjournal.blogspot.nl/2013/09/dovetail-joints-and-other-things-that.html>

Figure 20 - Dovetail joint
Source: <http://dovetailworkshop.com/>

Figure 21 - Timber joinery
Source: <http://fabcab.com/>

Figure 22 - timber frame scarf joint
Source: <http://www.timberframe.ch/holzbaue>

Figure 23 - Frame + Panel design
Source: <http://mocosubmit.com/f>

Figure 24 - Simple Shelf Design
Source: <http://imwm.org/simple-commodity-shelf-design/>

Figure 25 - Bamboo Connection Detail
Source: <http://www.archdaily.com.br/>

Figure 26 - Pine Wood Stool
Source: <http://www.wisdesign.se/>

Figure 27 - Alex Building System
Source: <http://www.betterlivingthroughdesign.com/category/furnishings/storage/shelves/page/2/>

Figure 28 - Alex Building System
Source: <http://www.betterlivingthroughdesign.com/category/furnishings/storage/shelves/page/2/>

Figure 29 - Shigeru Ban paper in architecture
Source: www.world-architects.com/pages/insight/materials-shigeru-ban

Figure 30 - Bamboo construction detail
Source: <https://affordabledream.wordpress.com/tag/construction-details/>

Figure 31 - Engineered bamboo

Source: www.lamboos.us

PART 3 - CASE STUDIES

Figure 32, 33 & 34 - BIG Serpentine Pavillion
Source: <http://compositesandarchitecture.com/?p=4383>

Figure 35, 36 & 37 - German-Chinese House at Expo Shanghai
Source: <http://www.detail.de/inspiration/bambuspavillon-expo-schanghai-100371.html>

Figure 38, 39 & 40 - Japanese Pavilion at EXPO Hanover
Source: <http://www.detail-online.com/inspiration/japanese-pavilion-at-the-expo-in-hanover-106867.html>

PART 4 - ACETYLATED WOOD

Figure 41, 42 & 43 - Acetylation Process
Source: All images by Accoya

Figure 44 - Accoya wood. Source: Accoya

Figure 45 - Sneek Bridge in The Netherlands.
Source: inhabitat.com

Figure 46 - Dimensional Stability. Source: Graph by Accoya

Figure 47 - Durability Graph. Source: Graph by Accoya

Figure 48 & 49. Durability Tests. Source: Images by Accoya

Figure 50 - Moses Bridge in The Netherlands
Source: feel-planet.com

Appendix 2 - Interviews

Interview with Accsys Group (Accoya Wood)

Company: Accsys Group (Accoya Wood)

Interviwee: Kees Verlaan

Interviewer: Manuella Borges

Date: December 2nd, 2016

Topics Discussed: Wood treatment, imports, manufacture, distributions, advantages, sustainability, circularity

Interview:

1. How does Accoya implement circularity in the whole process of treating wood?

My specialty in Accoya is the technical support of architects and joinery contractors, and not circularity specifically. As far circularity is involved Accoya can be used in a second life. We have a Cradle to Cradle gold, which is one of the highest certificates.

2. So, what makes Accoya products Cradle to Cradle gold certified?

Some aspects of Accoya wood are Cradle to Cradle platinum, but all of them have to be platinum in order to be considered platinum certified. Since one aspect (durability) is gold, then Accoya wood is also Gold certified, which is also a big statue.

What makes it gold is not the type of wood, but the process: how we deal with energy, water supply, etc.

When you compare to other wood species, it is durable in the forests already. That's where it begins.

3. So, the wood itself is called Accoya?

No, Accoya is the process. The wood species is Radiata Pine. It comes from New Zealand.

4. Why New Zealand? Why not Finland or Germany?

Because there are a lot of forests in New Zealand already. New Zealand and Australia are using Radiata Pine. The trees in Scandinavia use furen. But we cannot use furen in our process, because it is too closed and we need an open cell structure. That's important because our process uses vinegar and it must be into the core of the wood and we cannot succeed in that with furen.

5. In what shape do you import this wood?

We do not import the logs, but the wood already cut in several dimensions. It is already dried, put in a container and shipped to Arnhem. We are the only the only factory in the world.

6. So, Accoya manufactures everything in Arnhem and then export again?

Yes, sometimes to New Zealand.

7. Does Radiata Pine take very long to grow?

No, it is a fast-growing wood species. Here it is a sample of laminated wood and here you can see how fast it grows. This is a growth size you never see in other wood species. The tree is around 30m high and 60cm wide after 30 years.

8. What is Tricoya? Is it some kind of processed wood or made of waste?

Tricoya is made of the fibers of Accoya. When you put it in water, nothing happens to it. When Accoya is coming out of the process and some boards are cracked, we cannot sell them and then they go to Ireland, they are crushed and made into fibers. These fibers are compressed and then transformed into Tricoya. It is a water-resistant product, which is really important in a wet climate, such as in The Netherlands and it has a competitive advantage over other products that is not as water-proof.

9. What then makes it so water-proof?

When you put Accoya products in water nothing happens. Different from untreated wood, Accoya wood barely shrinks and swells.

10. So far we haven't found any significant links to circularity in wood since it is mostly used as biofuel at the end of its life. Some studies suggest that by 2030 there will be more demand for biofuel from wood demanding more extraction of wood directly from the source. I wanted to hear if Accoya has any plans for circularity or if it is just import, transform and selling it?

That's a short way to put it. Our sustainability manager gives very regular presentations to architects and local authorities about sustainability and circularity.

11. Who is typically your client?

It begins mostly with the architects. Nowadays, a lot of architects who are looking for circularity and sustainability contact us. They products can be anything from cladding, to windows, doors and structural applications.

12. Is the price of Accoya wood higher than non-treated wood?

If we compare it to mahogany, for example, it is 1300 to 1400 euros/m³ and Accoya will be 1600 euros/m³. So, it is a bit more expensive than normal wood species but its maintenance of Accoya is much less, so the clients save money on maintenance.

13. Your business is dependent on one type of wood species, is that why Accoya is looking for alternatives?

I think so. We can do a lot of things with Radiata Pine and Accoya. But we are testing other species, such as Beech, which is harder than Accoya and that's how it came in. The Beech species is very good in the acetylation process.

14. Does Accoya have visibility on how the forests (in New Zealand) are managed in terms of sustainability?

We have a good relationship with the forest owners and sawmills. They have to comply with the required certificate. It is part of the cradle to cradle system. It begins in the forest and it end with Accoya and everything in between.

Summary of presentation:

Accsys modifies wood on a molecular level. We change the building process in the cell walls of the wood. The building stones of the cell wall are hydroxyl and acetyl. There is more hydroxyl than acetyl, and what we do in the factory by adding acetate is that we change the hydroxyl and the acetyl parts. Hydroxyl goes down and acetyl goes up. Acetyl is the good piece of the wood and hydroxyl is the bad part of the cell wall. When water comes in contact with wood, then it naturally swells and cracks. But the acetylation process changes that. We do not add anything else in the wood such as chemicals, but only acetate (naturally from vinegar).

The acetylation process enhances the wood resistance to water and avoids swelling of the

wood, doors and windows. This is something that other species such as mahogany cannot provide. Therefore, we give a 50-year warranty on the wood with paint or without paint. Because Accoya doesn't swell or shrink then it is a very interesting product because it requires less maintenance, making the wood more stable.

The acetylation process goes right into the core of the wood. It is not simply an impregnation process such as the ones done with salt. But what we do is to go inside the center, the whole wood is modified and not only its surface.

Projects that have close proximity to the water such as bridges and pool decks can benefit from the water-resistant quality of Accoya.

Accoya wood can have an A1 quality with no knots, if required, since the branches are cut-off when the tree is growing. The branches are then burned. Architects can choose the grading (amount of knots) in the wood. The A2 quality has some knots in it.

Currently we are making some development using Beech wood species. We have made a bridge in curacao and we will monitor this project in order to see how it performs. Beech is not typically used outside, but mostly for furniture, floors, etc. If the wood proves successful after three years then we can commercialize it.

The common dimensions that Radiata Pine arrives in our warehouse has 25x100mm as the smallest piece and 75x150mm as the biggest one. The typical lengths are 240cm, 300cm, 360cm, 420cm and 480cm. For the finger jointed it is from 420cm to 600cm. In order to produce bigger pieces, the wood will need to be laminated.

The machining of the wood is the same as in normal wood, using the same types of tools and joineries.

We explain to customers that there is a bit of vinegar left in the wood and it smells as such. The clients need to pay attention to the coating, gluing and hardware. For example, they cannot use normal galvanized ironwork, it needs some coating on it because of the vinegar.

When used outside, Accoya has a light brown color because of the vinegar. During the process, we put vinegar under pressure and then vacuum it. All the connections and wood design is done by a third party. We only advise architects on how to do it best. We sell Accoya in 40 countries and our distributors take care of the final stage of the production.

Appendix 2 - Interviews

Interview with Limburghout

Company: Limburghout
Interviwee: Mark Jacobs
Interviewer: Manuella Borges
Date: November 27th, 2016

Topics Discussed: Wood species, imports, small business, challenges, wood in construction, sustainability

Interview:

1. Do you plant your own trees?
No, we get the tree logs from another party

2. Do these trees grow locally in the province of Limburg in the Netherlands?
No, local Dutch forests are not well cultivated and it is not a profitable business around here since forests don't give enough trees. Also, the soil minerals in the region do not produce as good of a tree as in Belgium, for example. Our tree logs come from Limburg in Belgium.

3. What are the most common tree species that you use?
We use mostly larch and oak. These trees come from certified sources. I also believe that they are very sustainable given that their sap cause the tree to become more self-preserving and self-resistant, decreasing rot.

4. In order to build a flexible system using wood, is it preferable to use smaller members combined together or larger members?
Bigger members are preferable since they will have less pieces and connections. Nowadays in construction sites, it is best to have bigger members that can be lifted and hoisted into place in as few parts as possible.

5. Forests in the Netherlands are mostly for recreation or preservation and not many forests are for the production and extraction of wood. What area in the Netherlands are known to have forests for this purpose?

The region near Utrecht and Arnhem has better soil and produce better quality wood. Also, the very south tip of the country has good soil. But here the soil is sandy and most wood species are softwood and pine trees, which were planted 60 to 70 years ago for the creation of poles and supports for the excavation of the mining industry. But slowly these forests are changing to low trees.

6. For structural purposes, what species you prefer?
Larch, oak and also Douglas, which is very popular because it is extremely straight and very easy to work with. But I like the character of larch more, its look and colour.

7. Do you do any kind of wood lamination here?
No, just solid wood. The laminating process requires a high investment for a small business such as mine.

8. When you get a client, then you saw the wood logs according to the needs?
Yes, absolutely. I make AutoCAD drawings from which I extract a saw list that goes into the saw mill. After the wood is sawn, we lay it to rest for a week or two, then we ship to the customer or bring to the workshop to further process it. This is the strong point and success of our company. We deliver to the client and either put it together ourselves or the client can also do it depending on the project.

9. Do you design your own connections?
Yes, I will show you in the workshop.

10. Do you think there is an increasing demand for wood products in the Netherlands?
Yes, I think so. People are looking for more natural products. Also, people are becoming more aware of environmental issues.

11. I was reading that in the Netherlands, there is a negative perception of using wood since people associate it with the fact that trees are killed. What do you think about this?

I personally never heard people saying that cutting tree is a bad thing. As in every country, I believe that there is a difference between the city people and the local people.

12. And what is that difference?
I think people in the city treasure forests much more than people in the rural areas because they have grown up with it seeing how trees grow and are cut, in what they understand to be a cycle. But if you are looking globally, I think your statement about the negative perception of using wood in the Netherlands is absolutely true. The reason why is that most wood in the country is not locally grown, but imported from abroad, including wood from rainforests. If you really have a heart for tropical forests, you have to quit your business and do not do it anymore. The whole FSC certification is mainly controlled by big businesses and I personally do not trust it a lot.

13. If a client wants to make lightweight structures using wood and if flexibility in size is a priority, what are the largest span you can produce in house?

The logs outside are approximately 22m in length. They could become one beam provided that you have a saw machine that can go all the way. I have a unique selling point: I can saw up to 12m, which is very unique here in the region. But if you say lightweight wood structures, you have to go to laminated wood. Also, a large span will demand a large depth that can only be obtained by lamination. If you look at laminated beams, from a structural point of view, there is not much difference in steel to wood. Although the breaking point and resistance are different, but from the calculation parameters on then they are very similar. So, why not make these beautiful ideas we have in steel using wood instead?



Pictures during site visit and interview. By author

Appendix 3 - Research Methodology Scheme

