



P5 presentation Bram Hulshof

Revitalising Heritage

Hembrug terrain, Zaandam
Ensemble: "Green Cape of the Head South"

30-01-2020

Content of presentation

2

- Research

*Hembrug
Ensemble
Buildings*

→ Conclusion/valuation

- Design

*Programme
Starting points
Master plan
Design (building scale)*

- Reflection

Hembrug - former function



Source: www.biedboek.nl



Source: www.zaansmuseum.nl

Hembrug - location



Map made by Sinan Aydin

Hembrug - emergence of the site

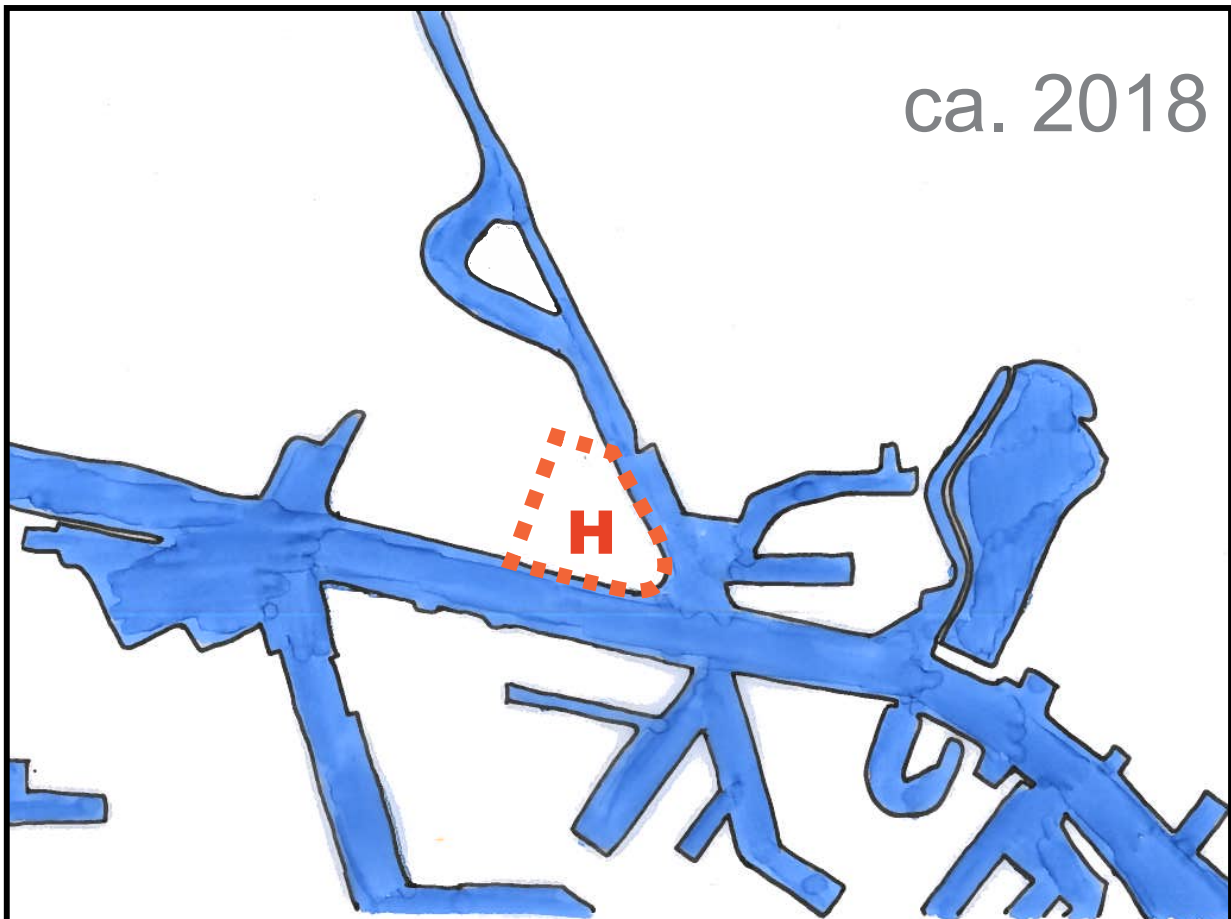
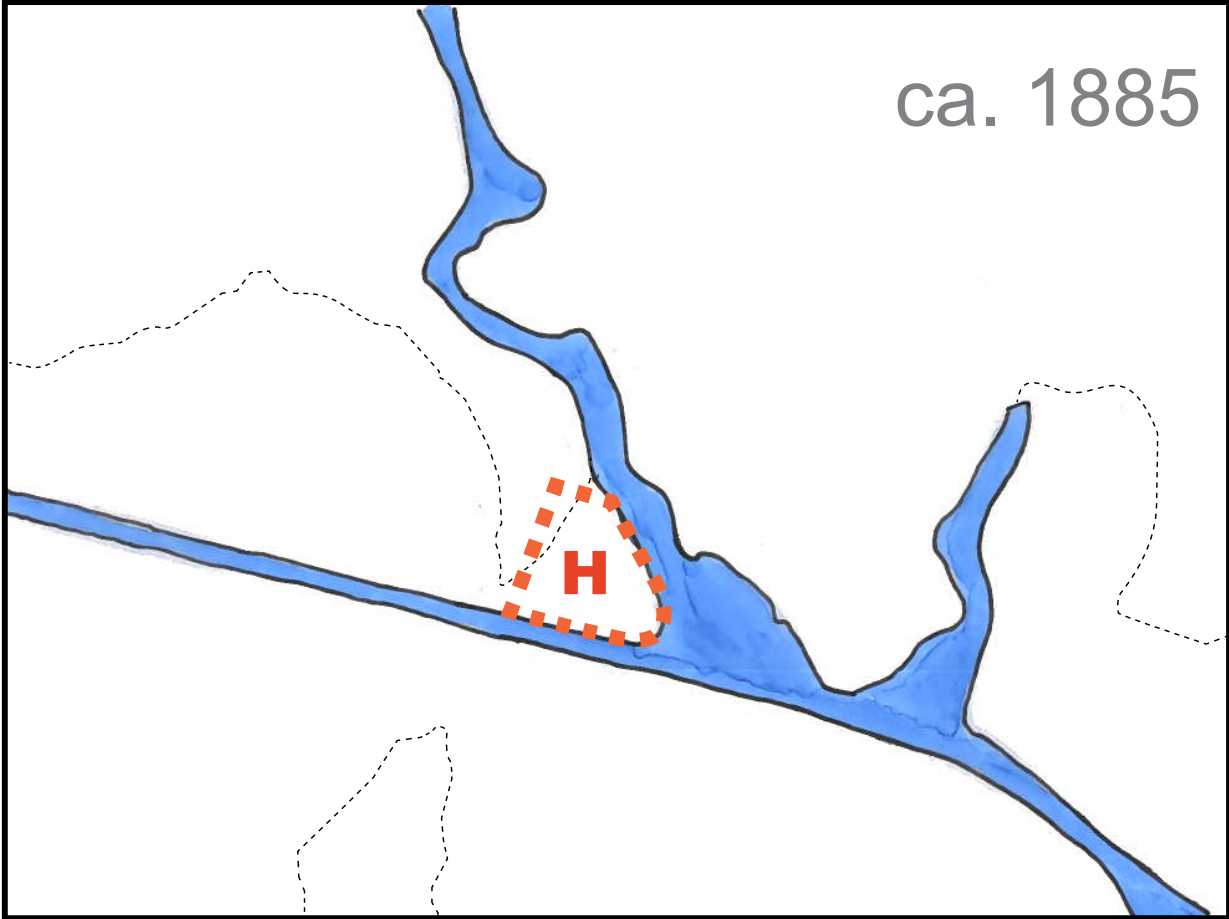
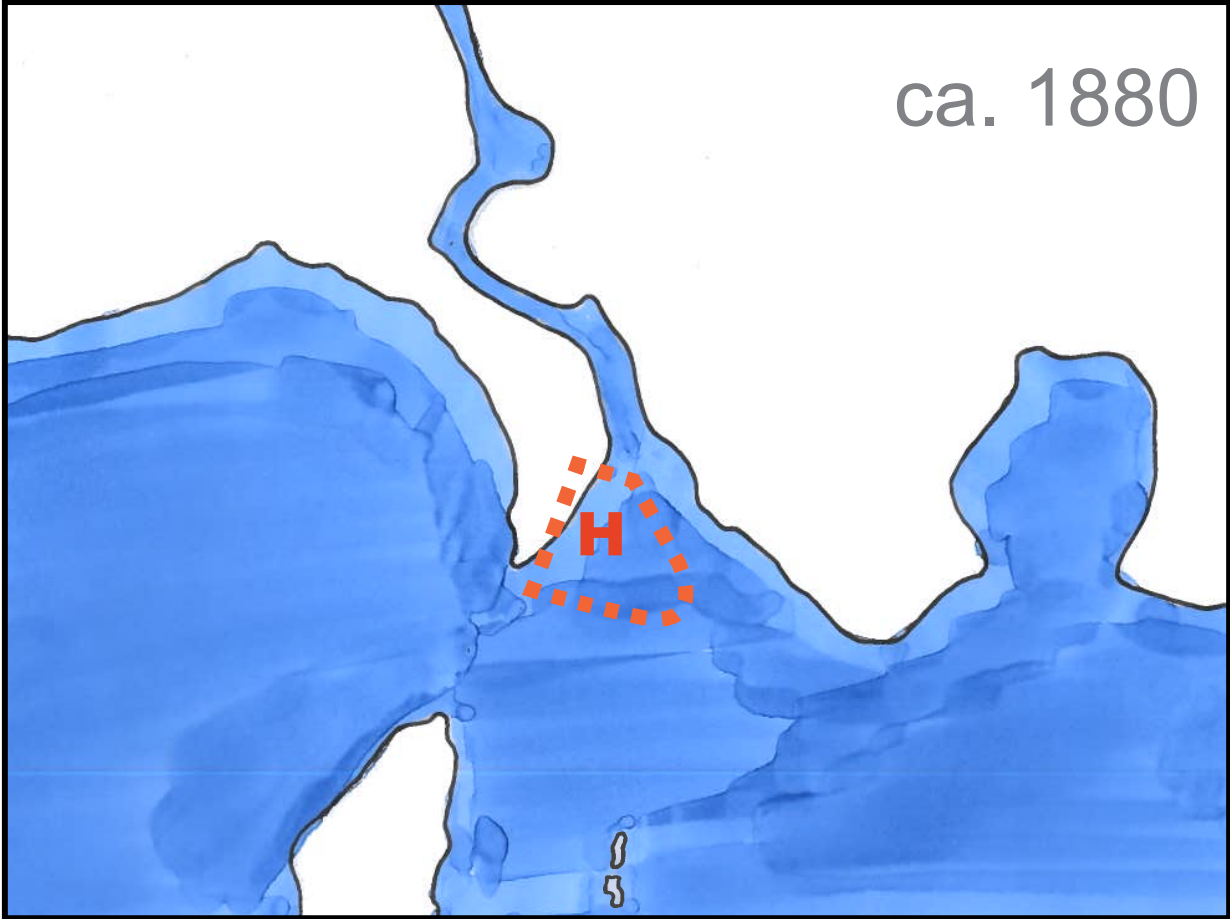

Hembrug - emergence of the site

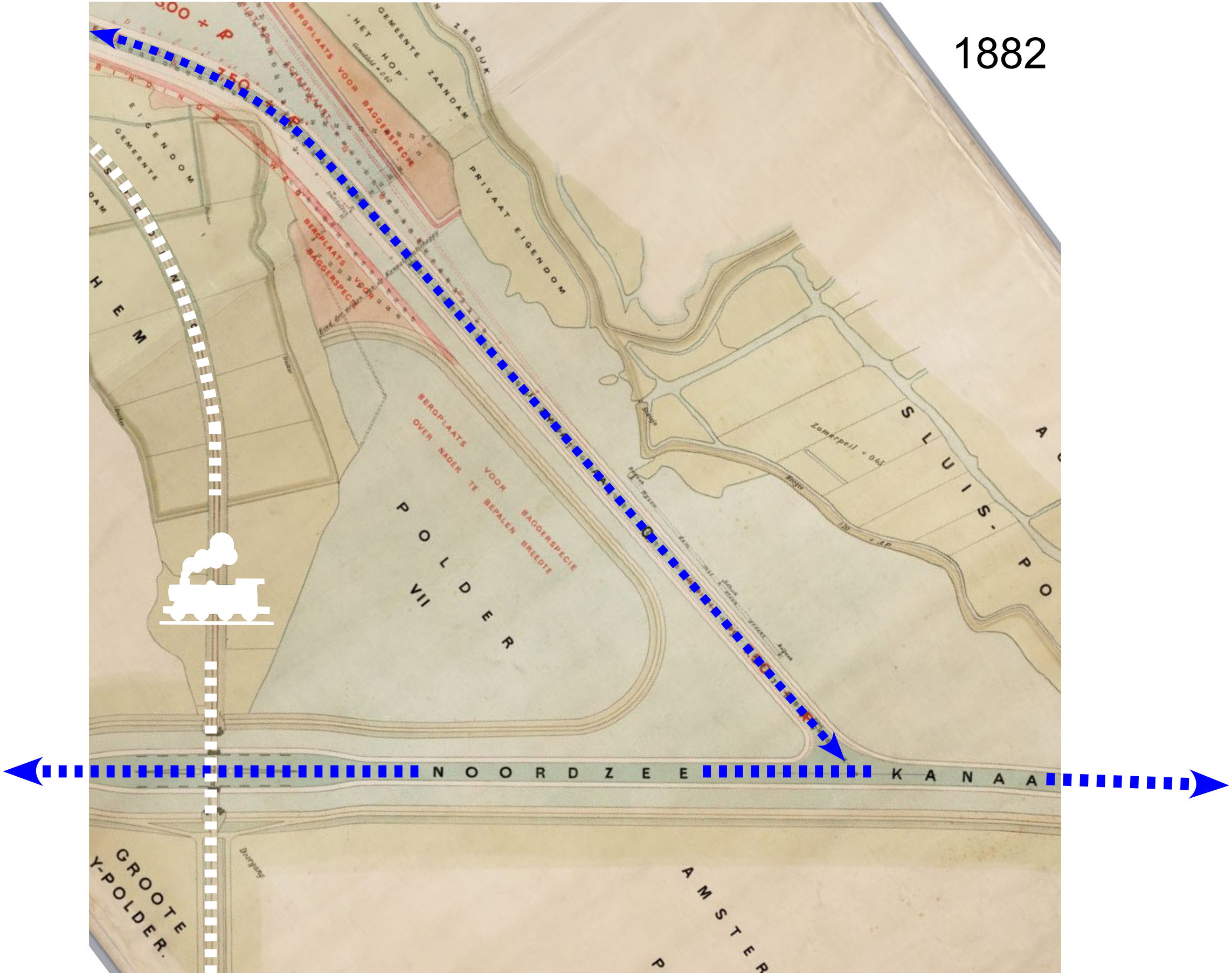

Source: Gemeentearchief Zaanstads, via www.zaans-industrieel-erfgoed.nl

Hembrug - functional layout 1924

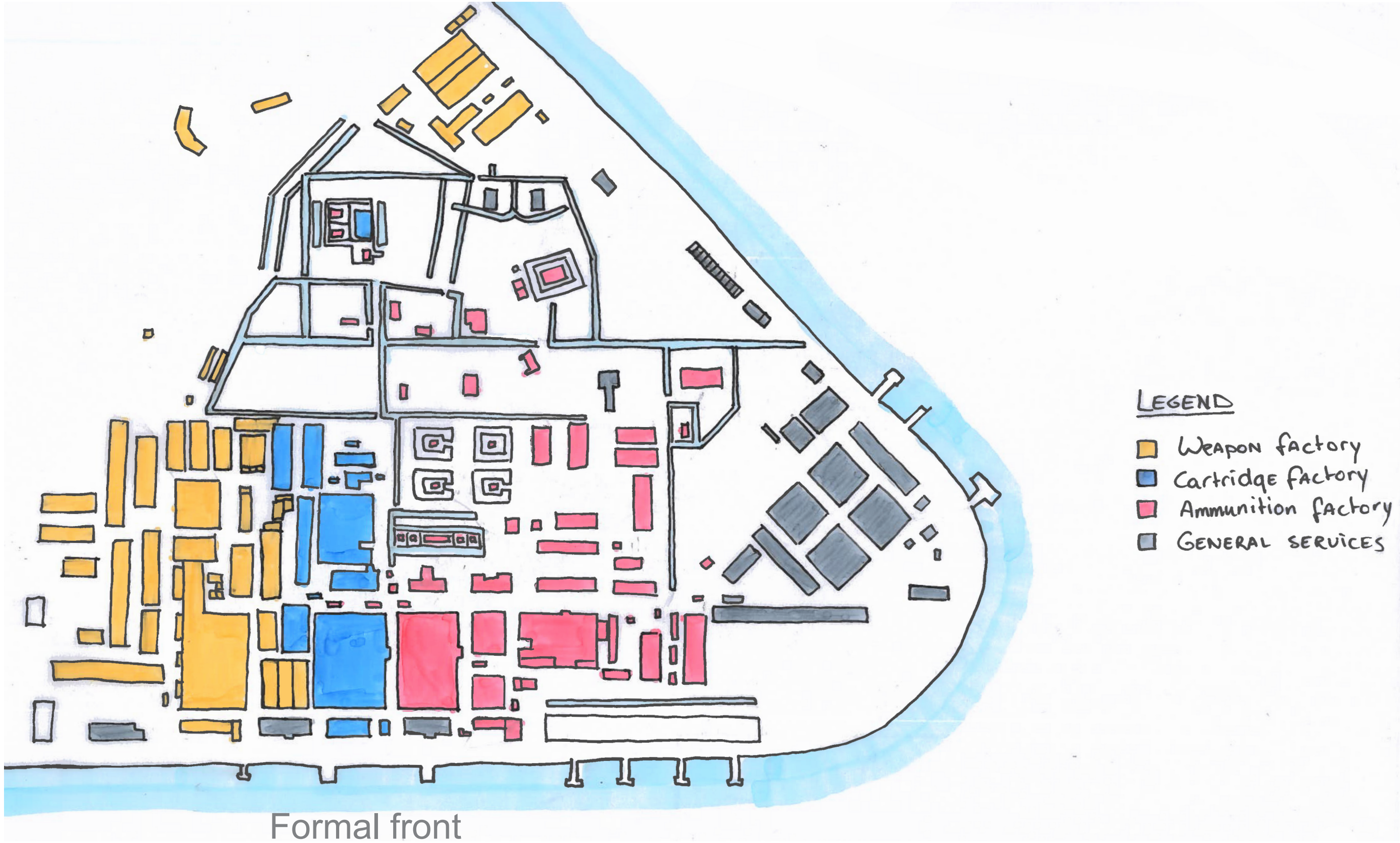

Hembrug - functional layout 1924

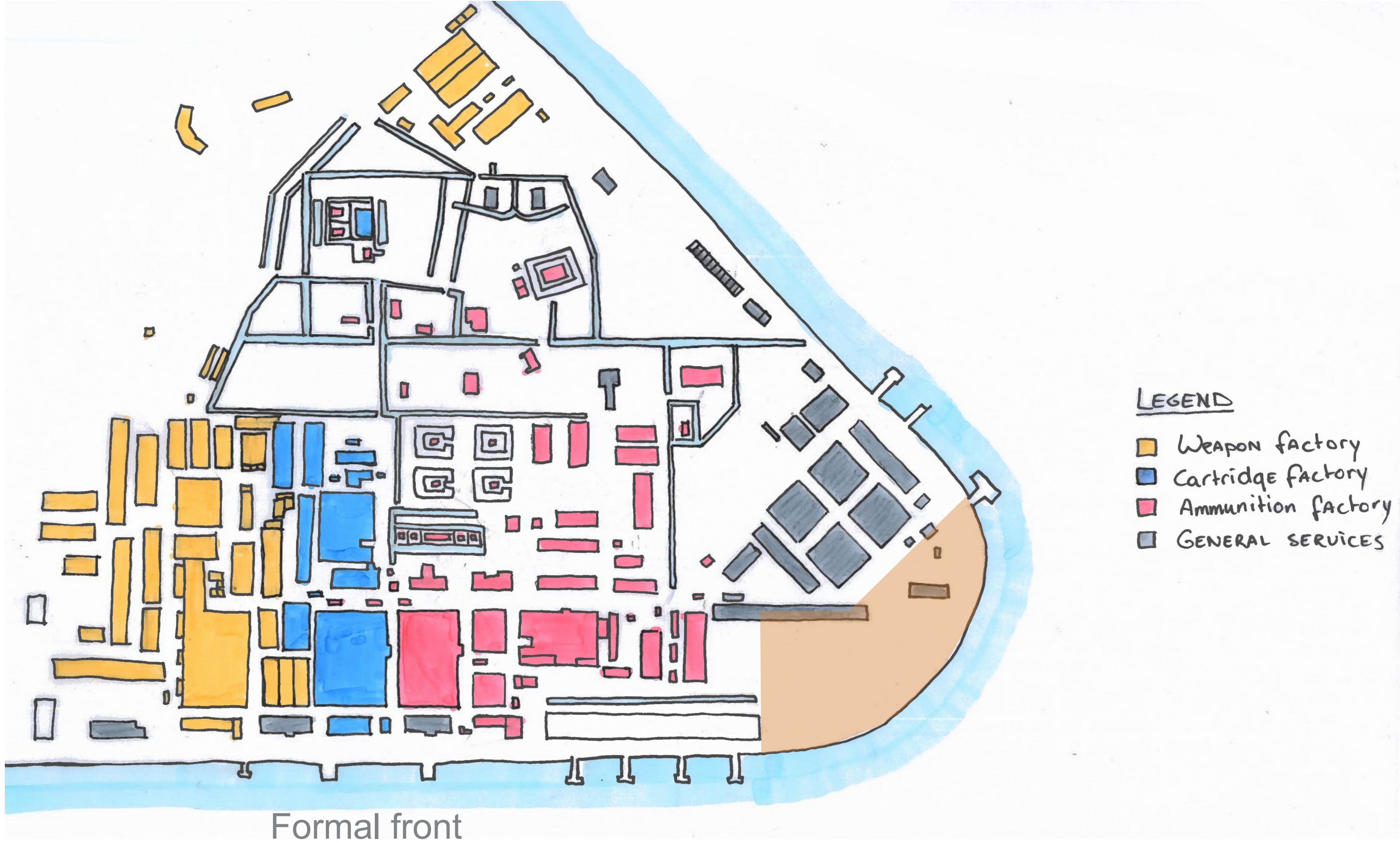

Ensemble - historical development

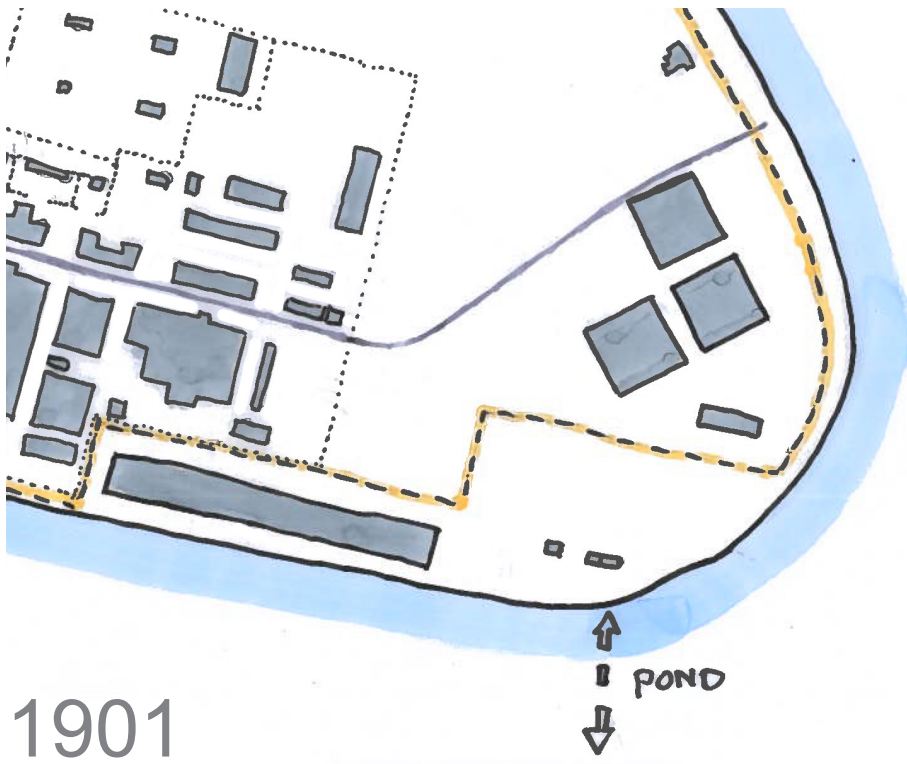

1901
Excluded

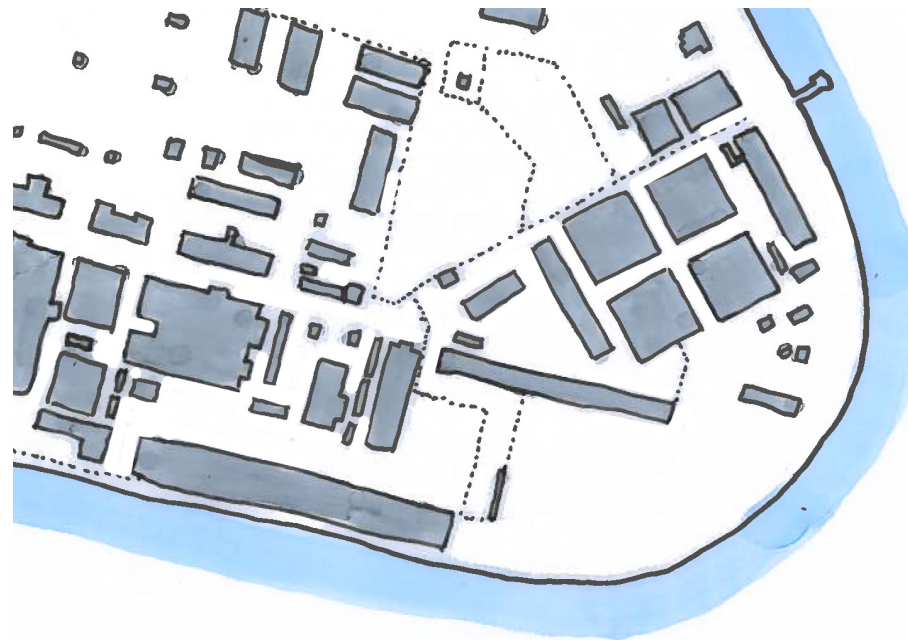

1924
Avoided

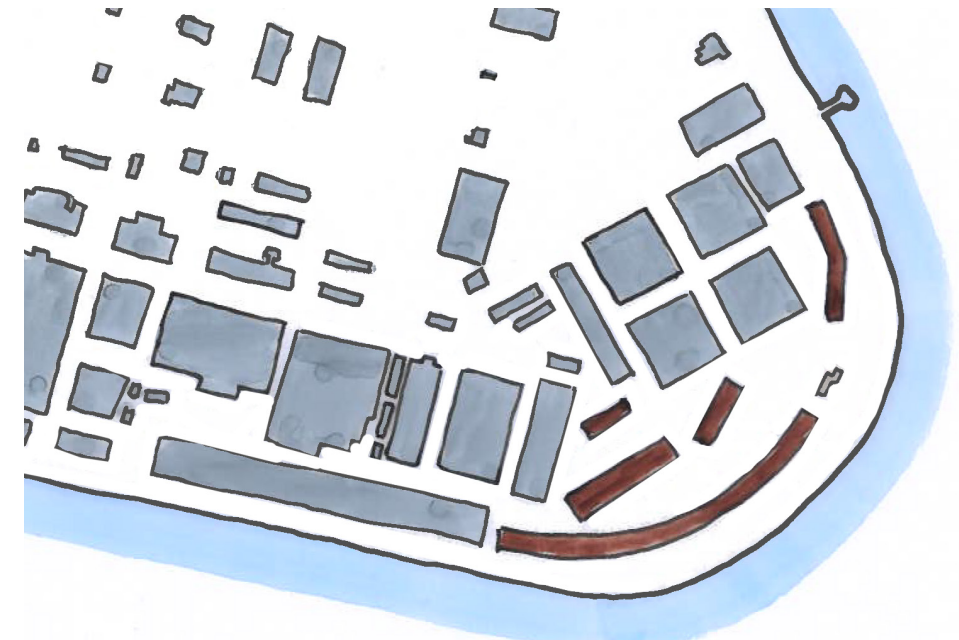

1941
Exploited

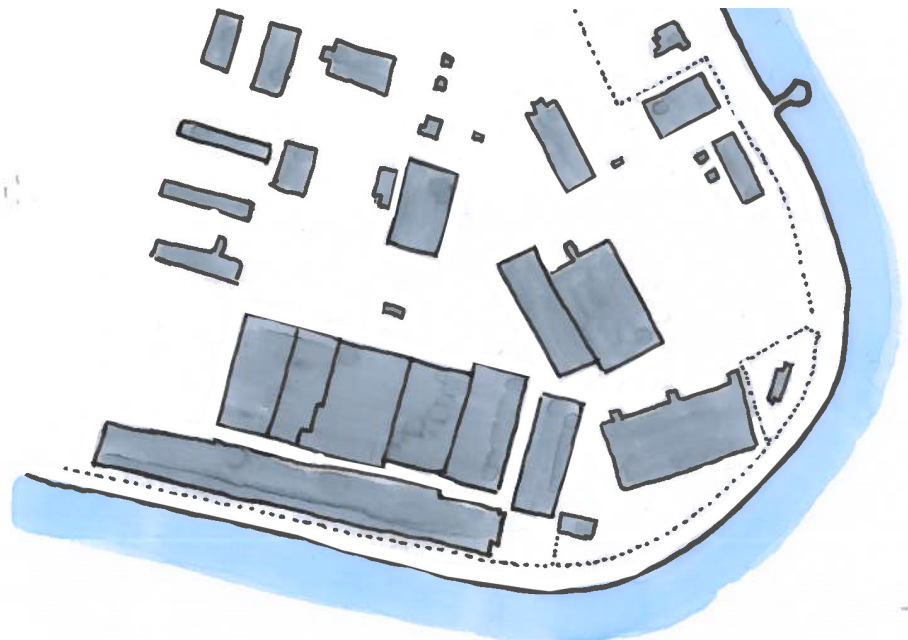

Current situation

Ensemble - overview

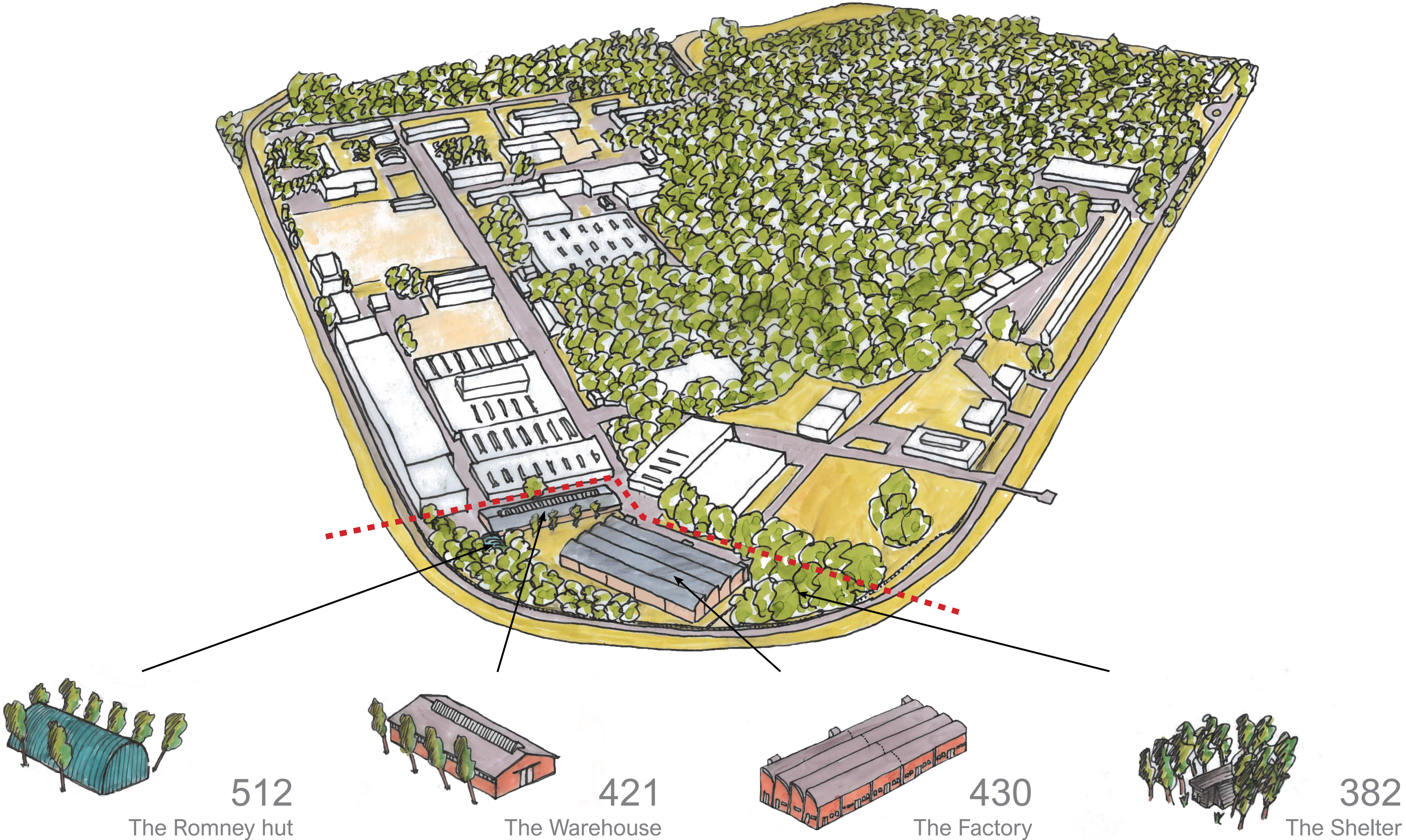

Ensemble - overview

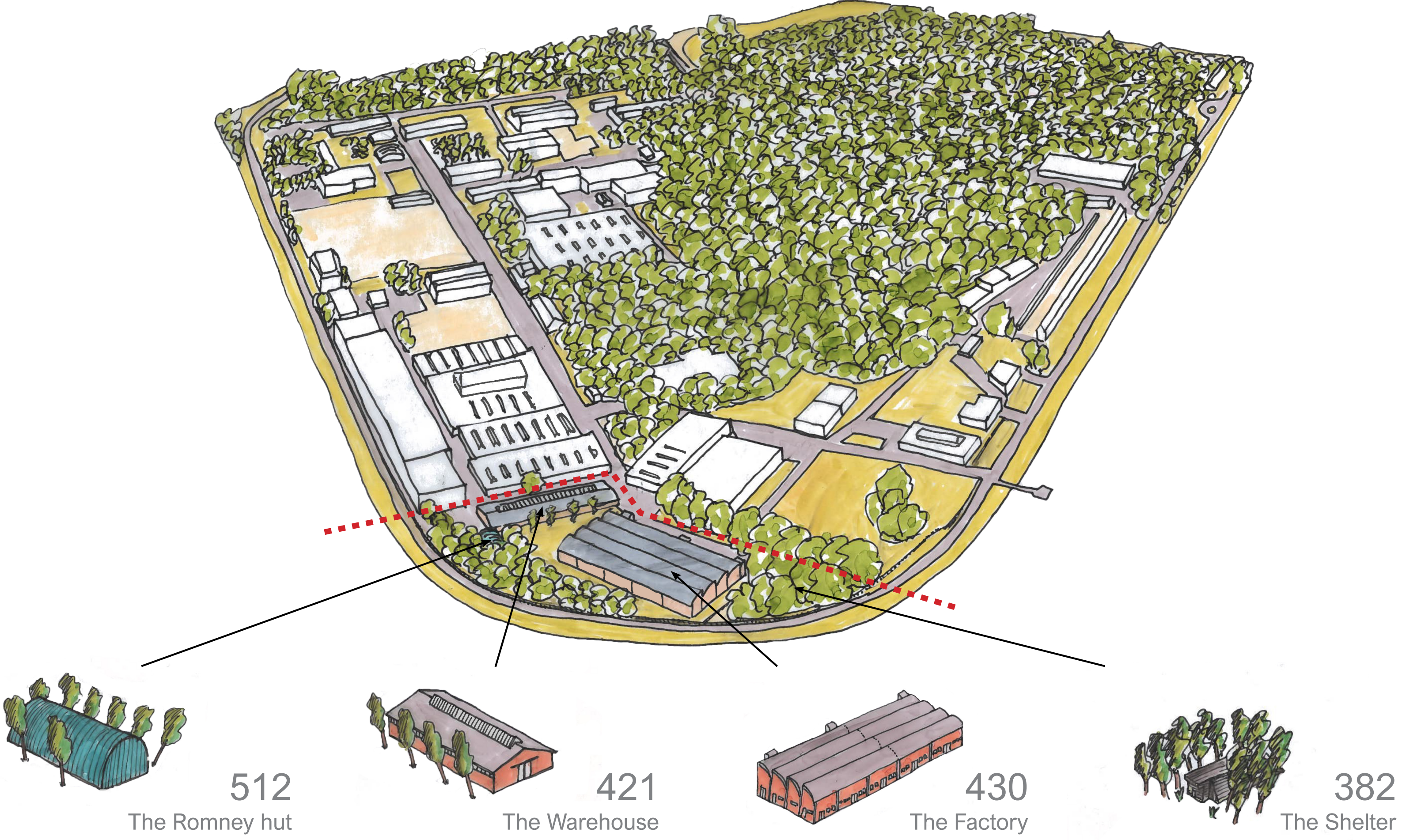

Romney Hut

Built: 1980

Function: Storage

Building number: 512

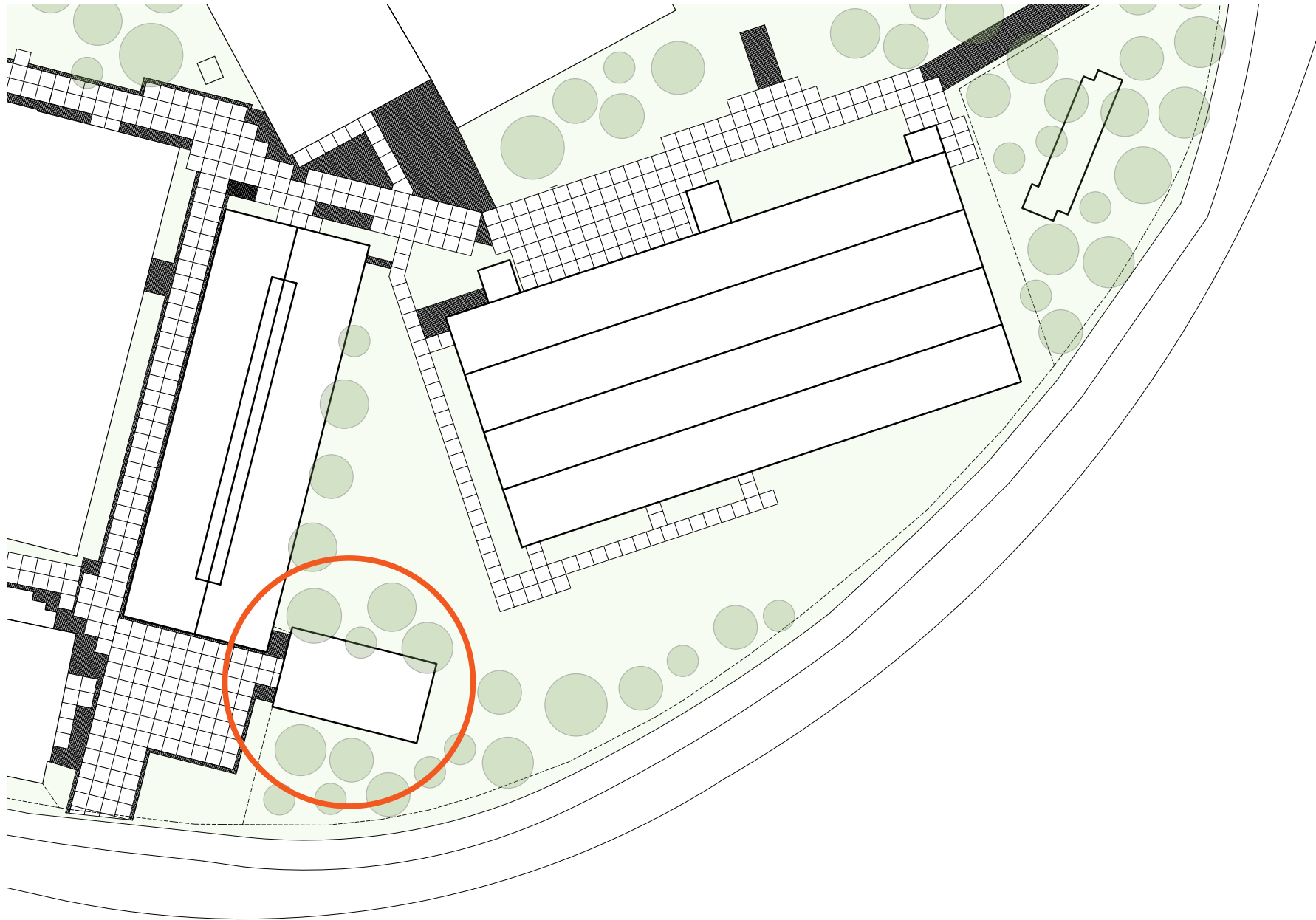
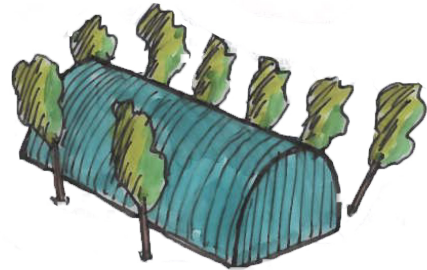

Romney Hut - essence

A green space divider

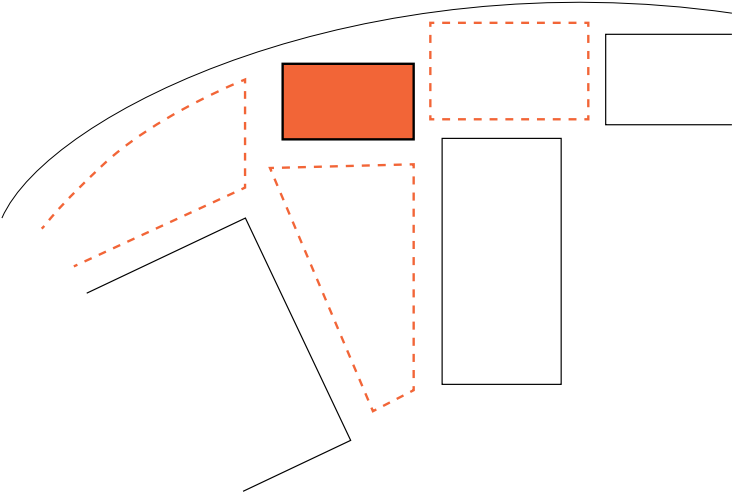
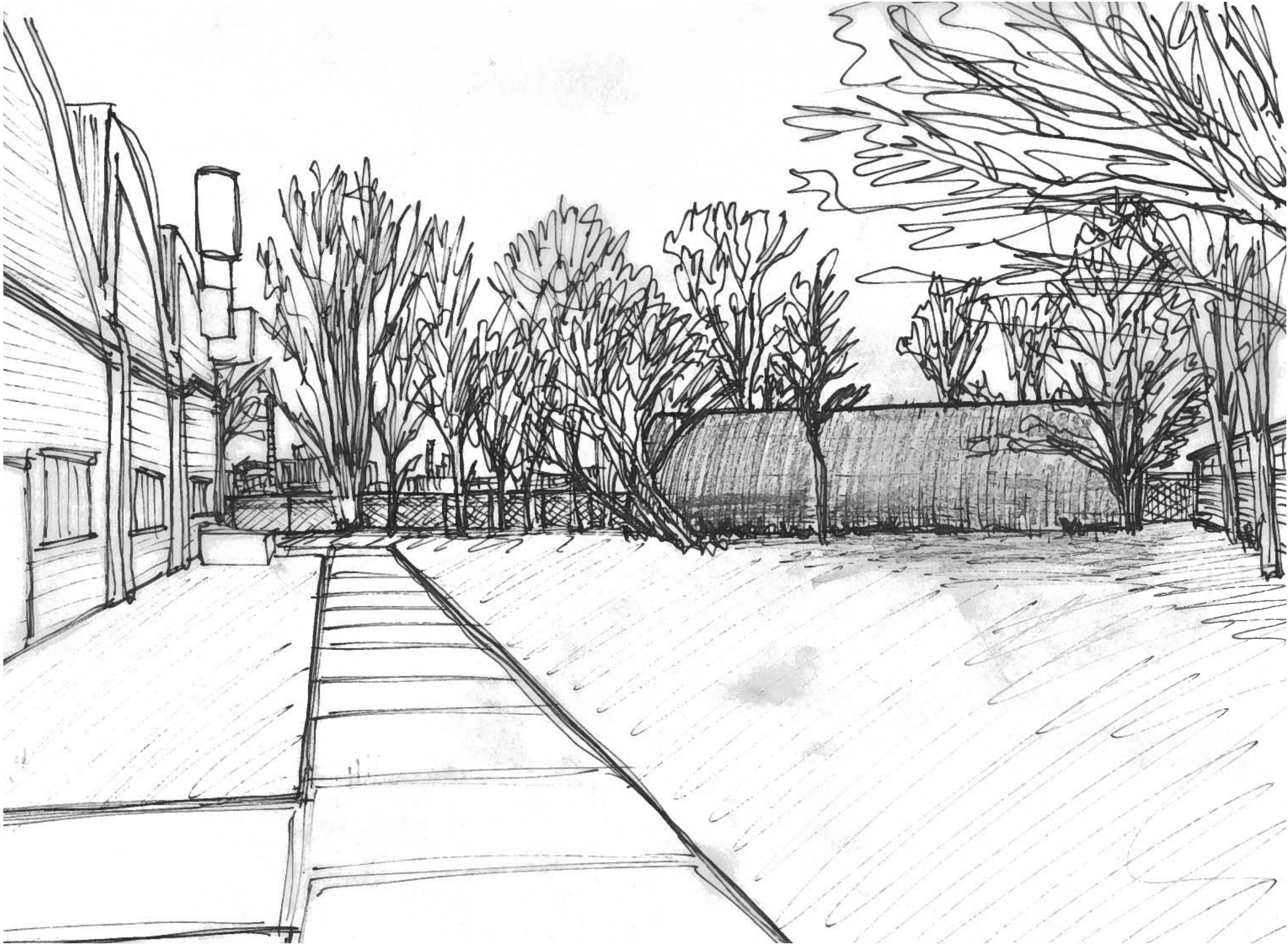

Defining public space

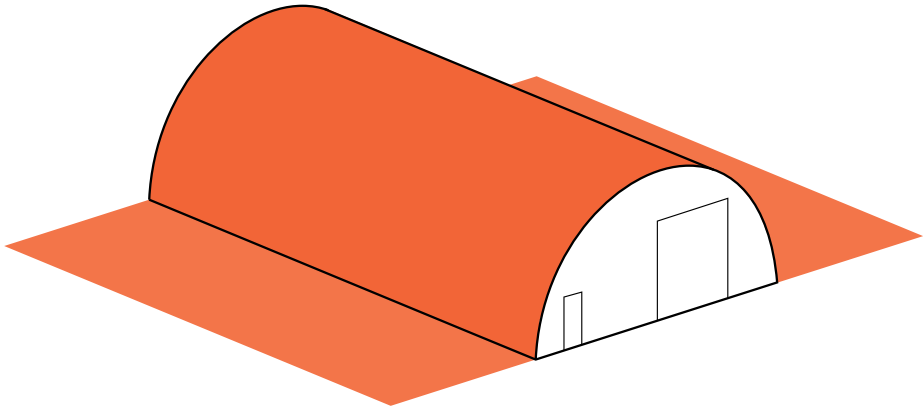

Simple geometrical shape

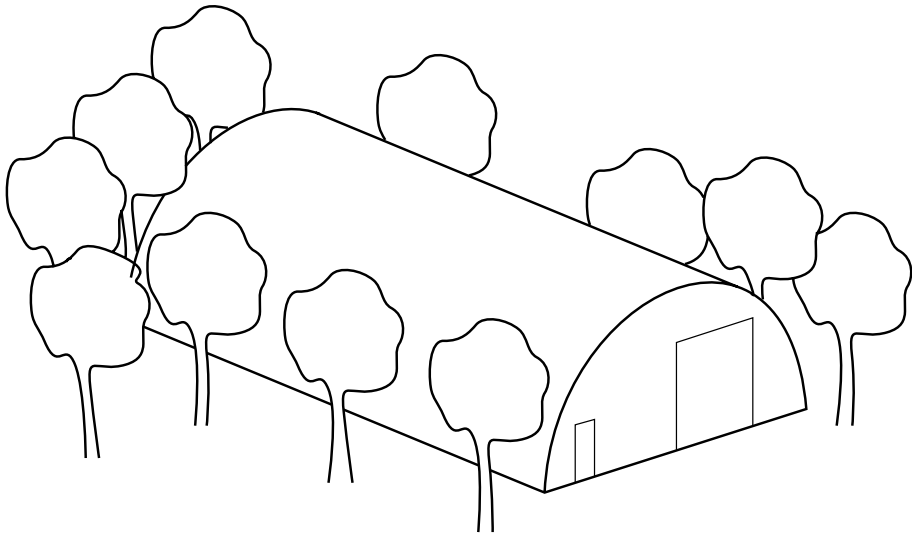

Enclosed by/overgrown with greenery

Ensemble - overview

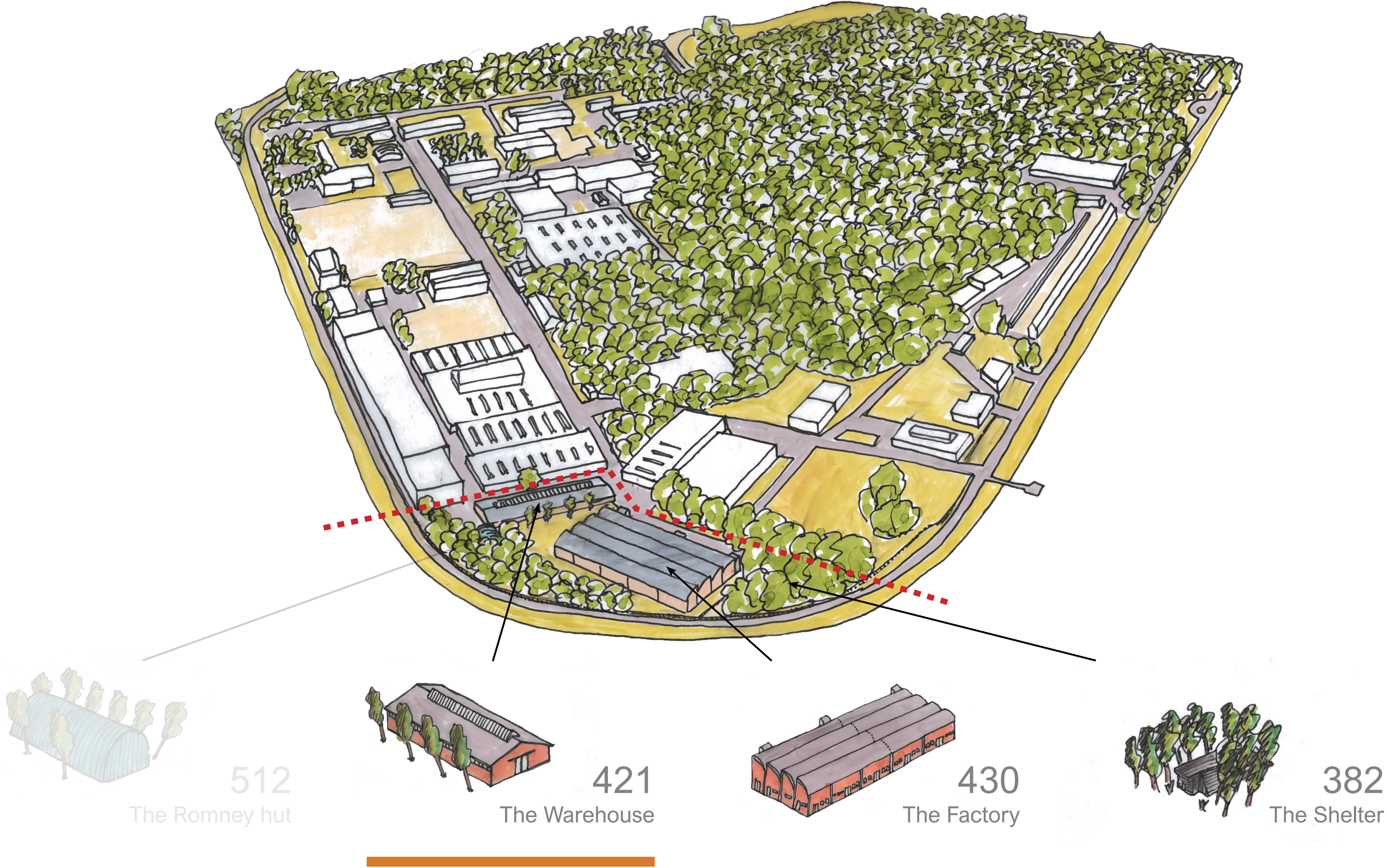

Warehouse

Built: 1952

Function: Storage/garage/wash house

Building number: 421

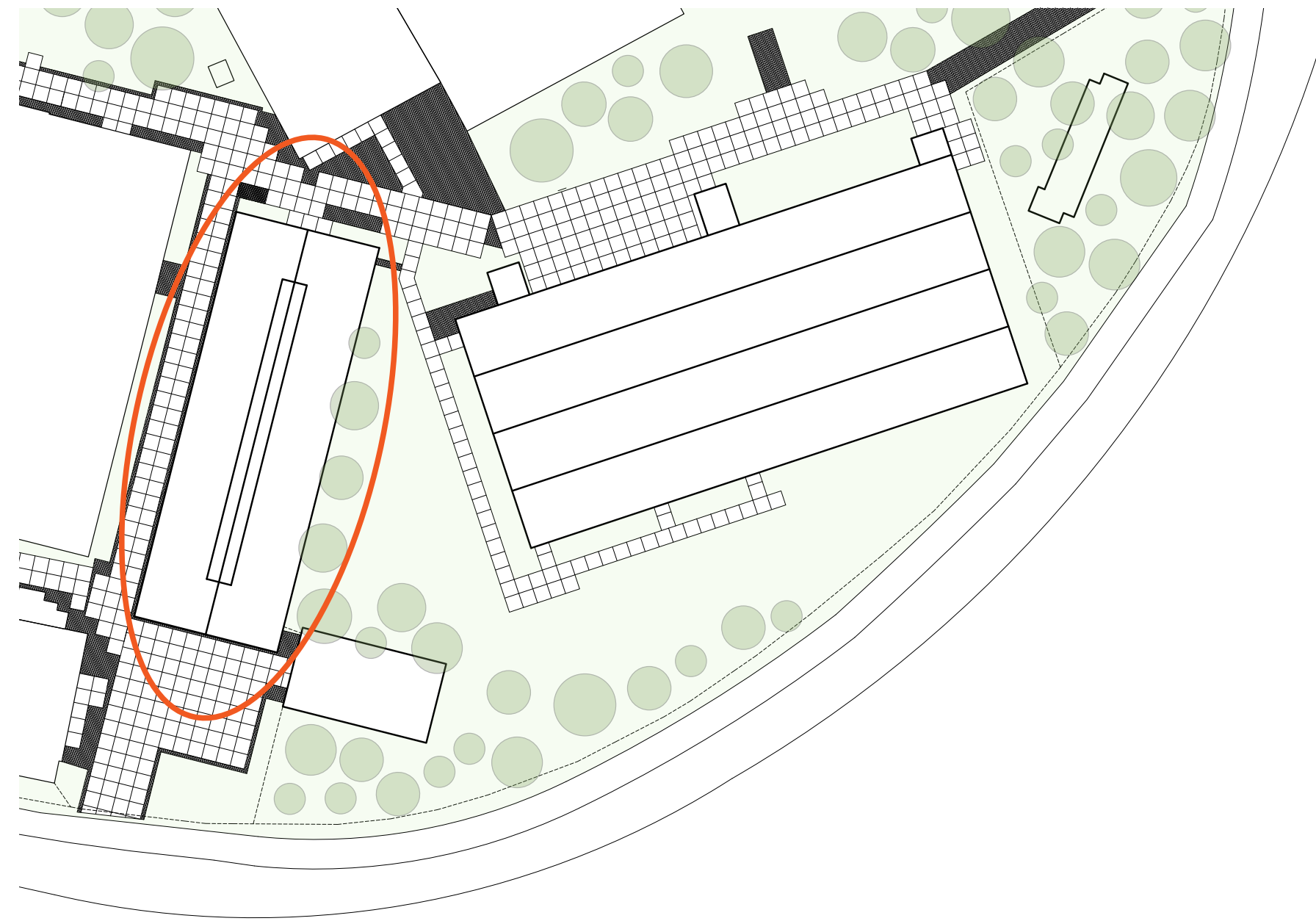
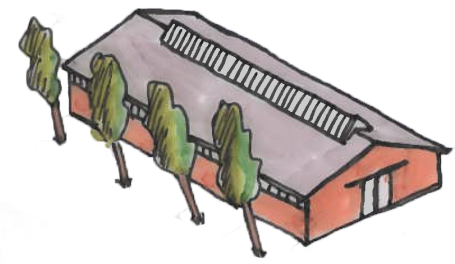

Warehouse - essence

A long servant

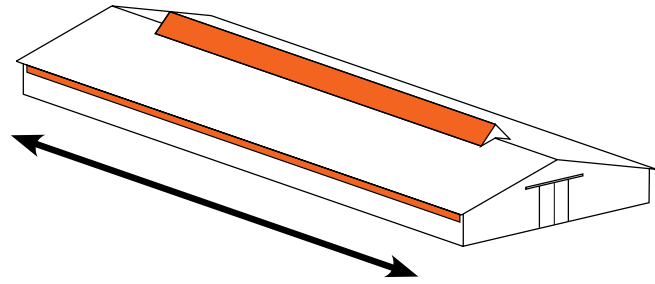
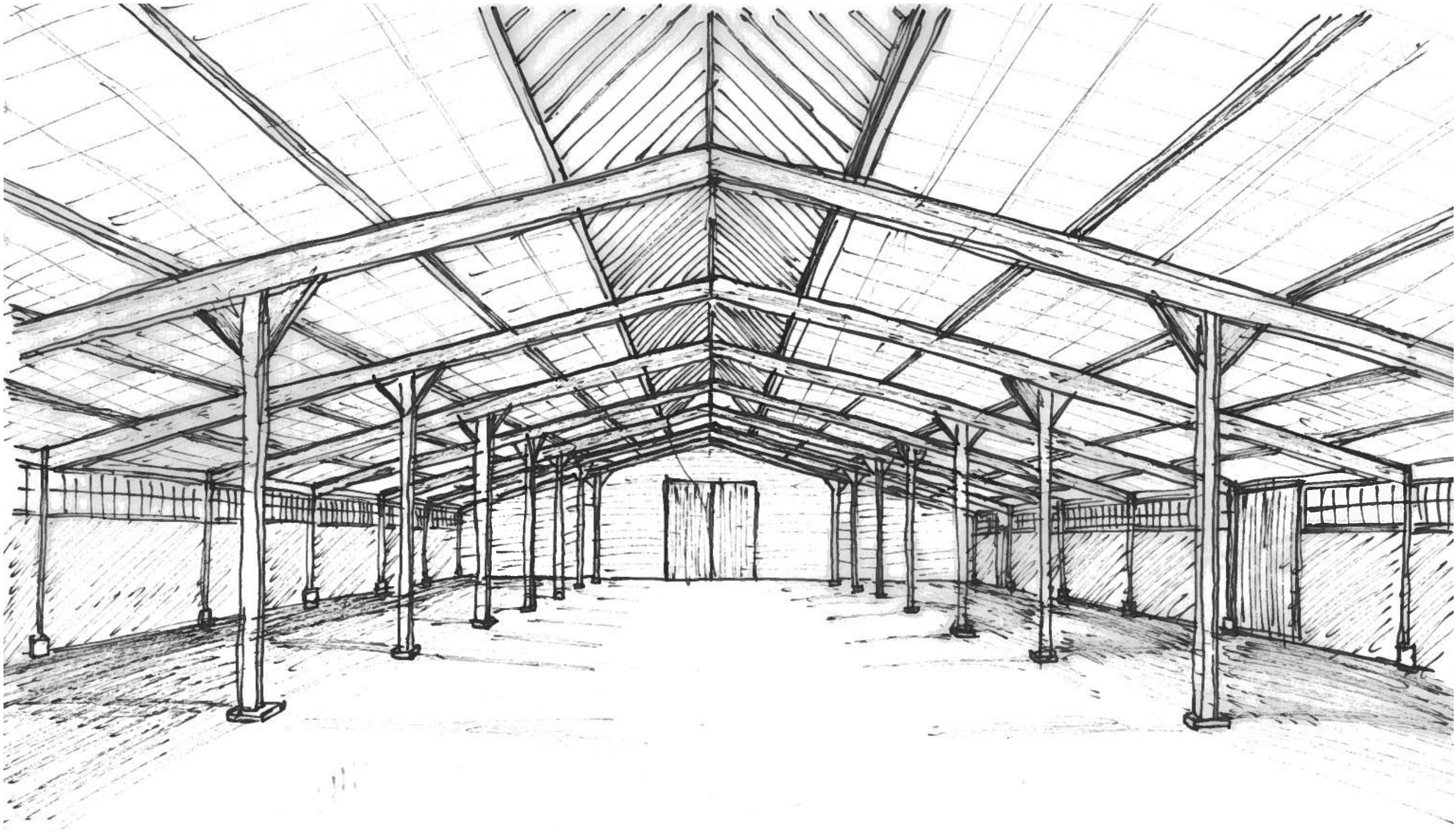

Length and horizontality

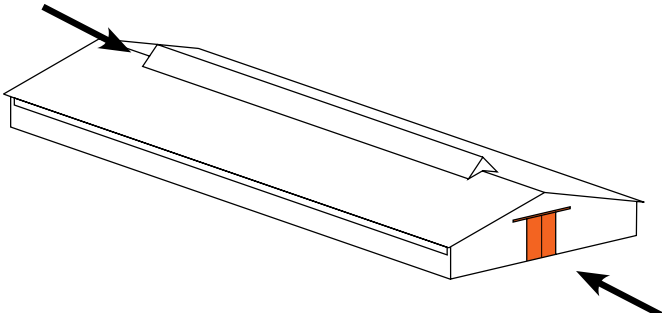

Main entrances

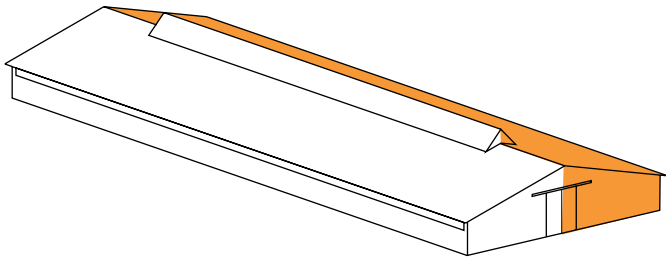

Symmetry

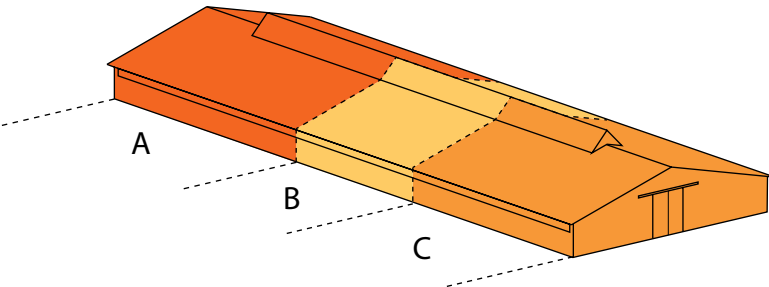

Serving character

Ensemble - overview

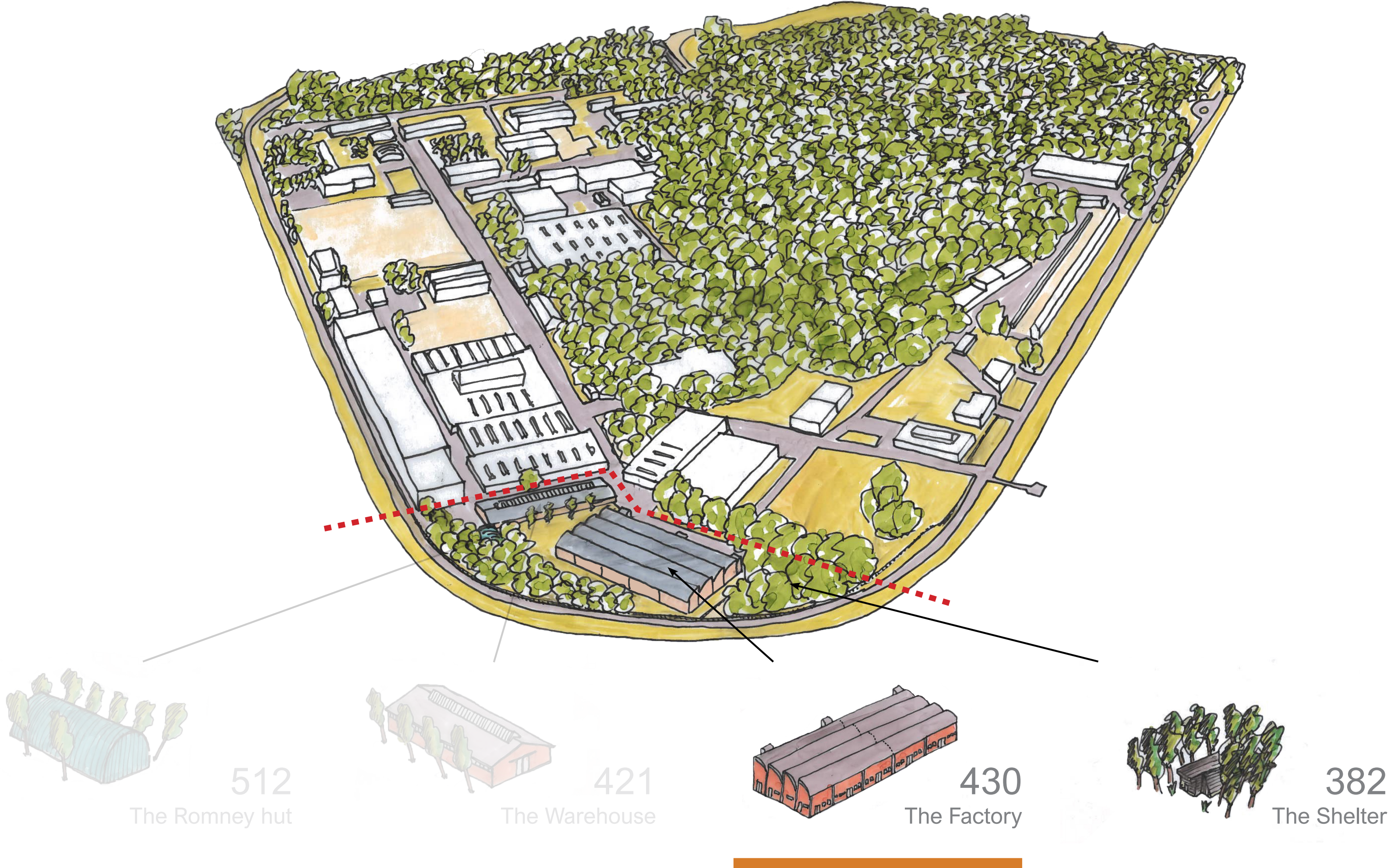

Factory - essence

Built: 1952-1958

Function: Assembling ammunition

Building number: 430a/b

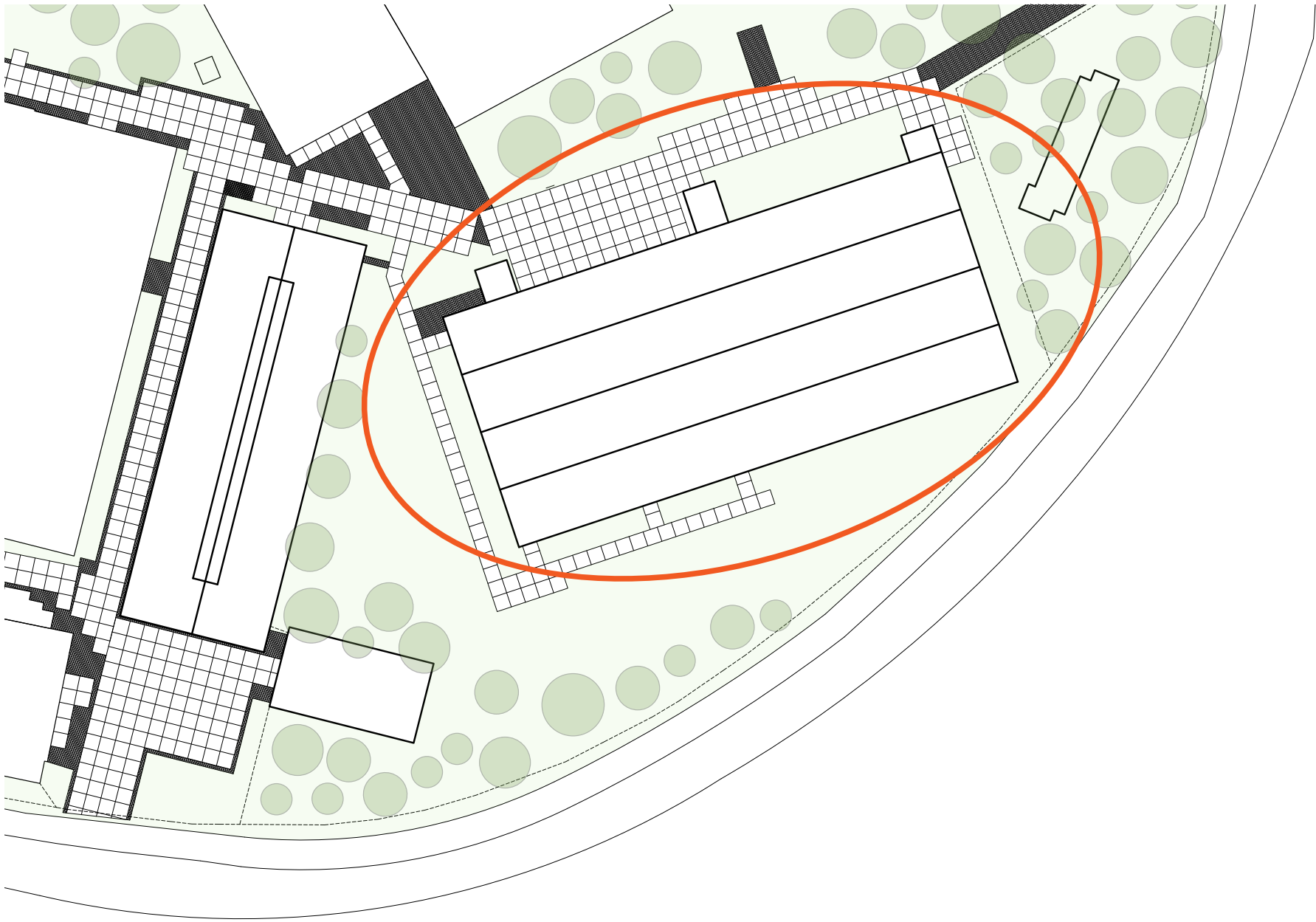
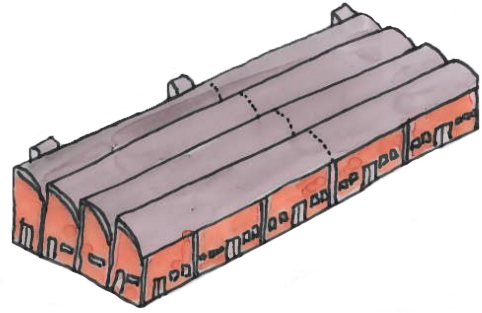

Factory - essence

A dominating individual

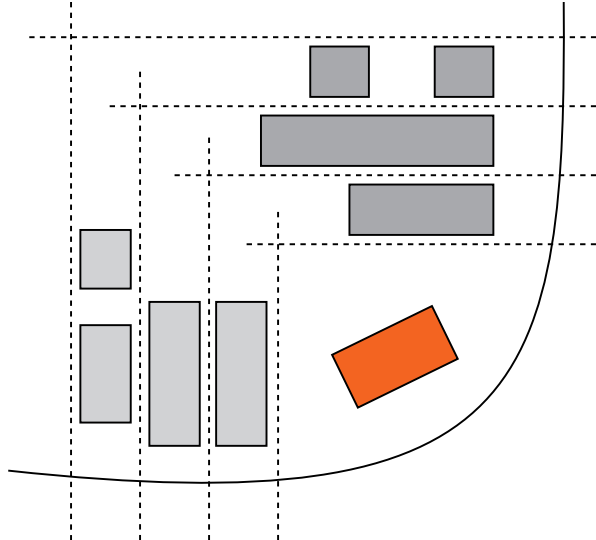

Setting itself apart

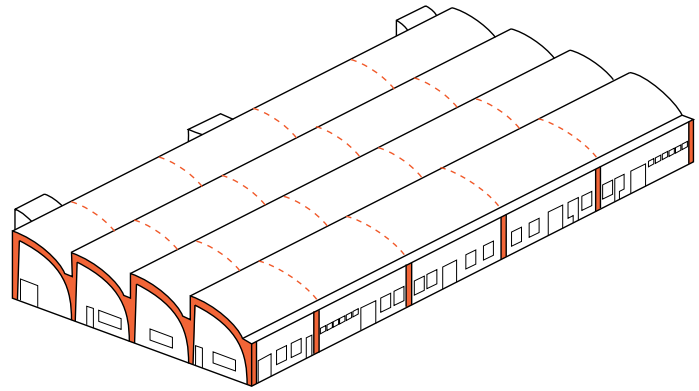

'Honest' visible structure versus infill

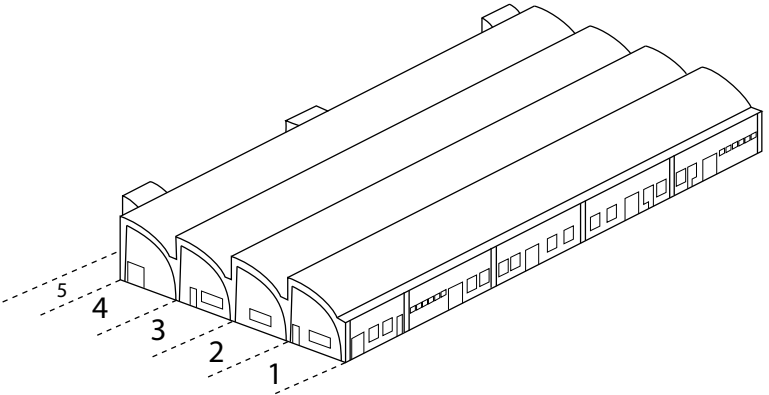

Sequence of segments

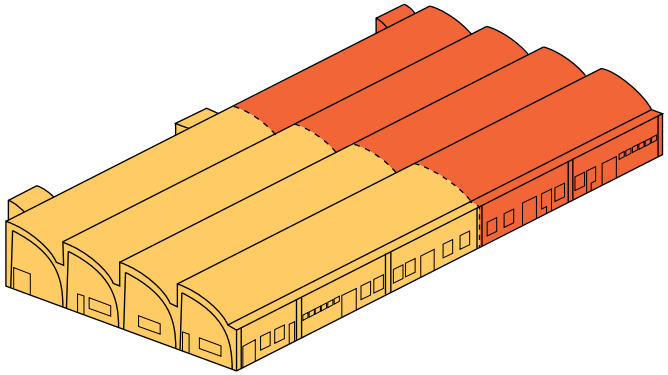

Two building phases

Ensemble - overview

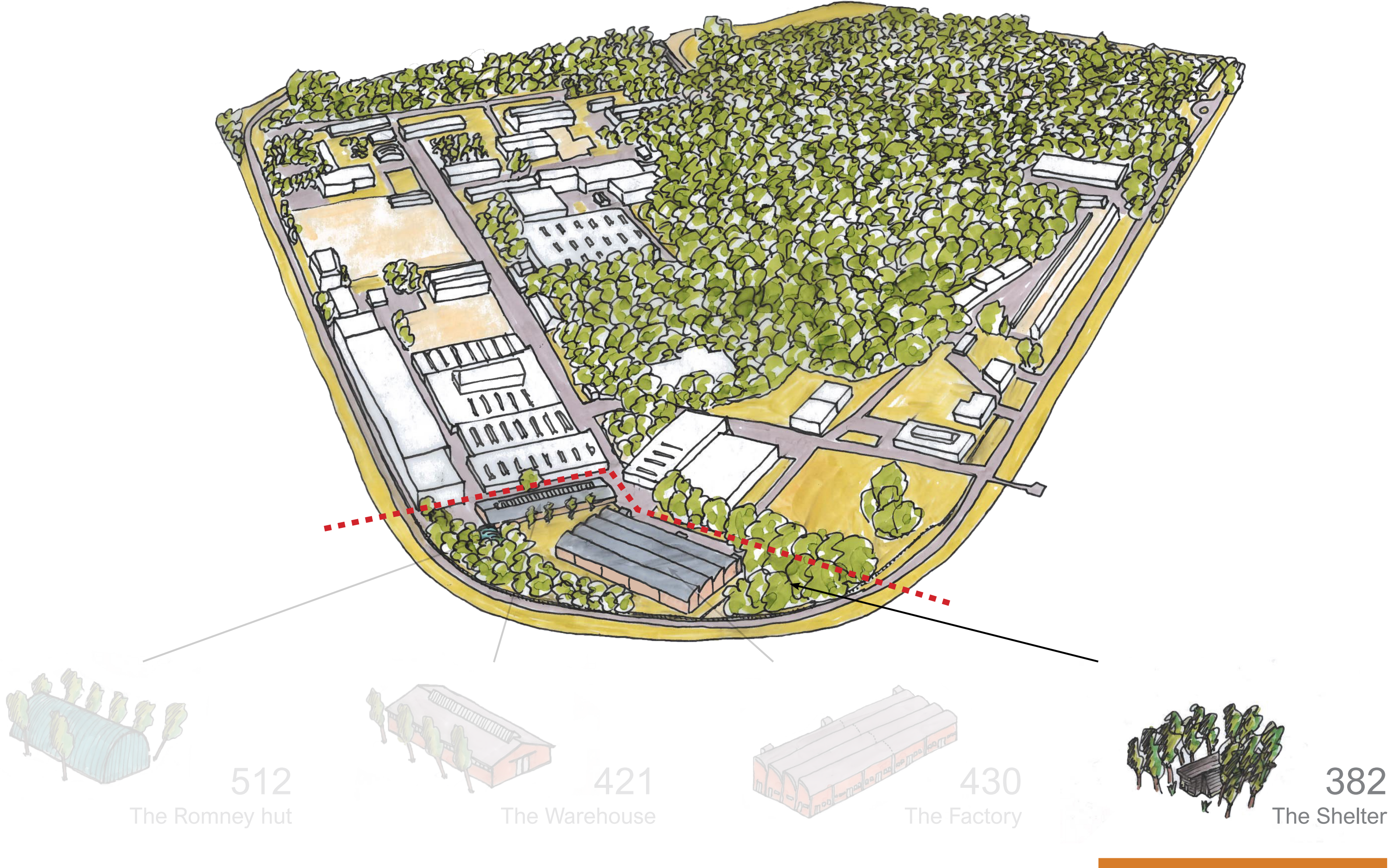

Shelter

Built: 1939

Function: Bomb shelter/command post

Building number: 382

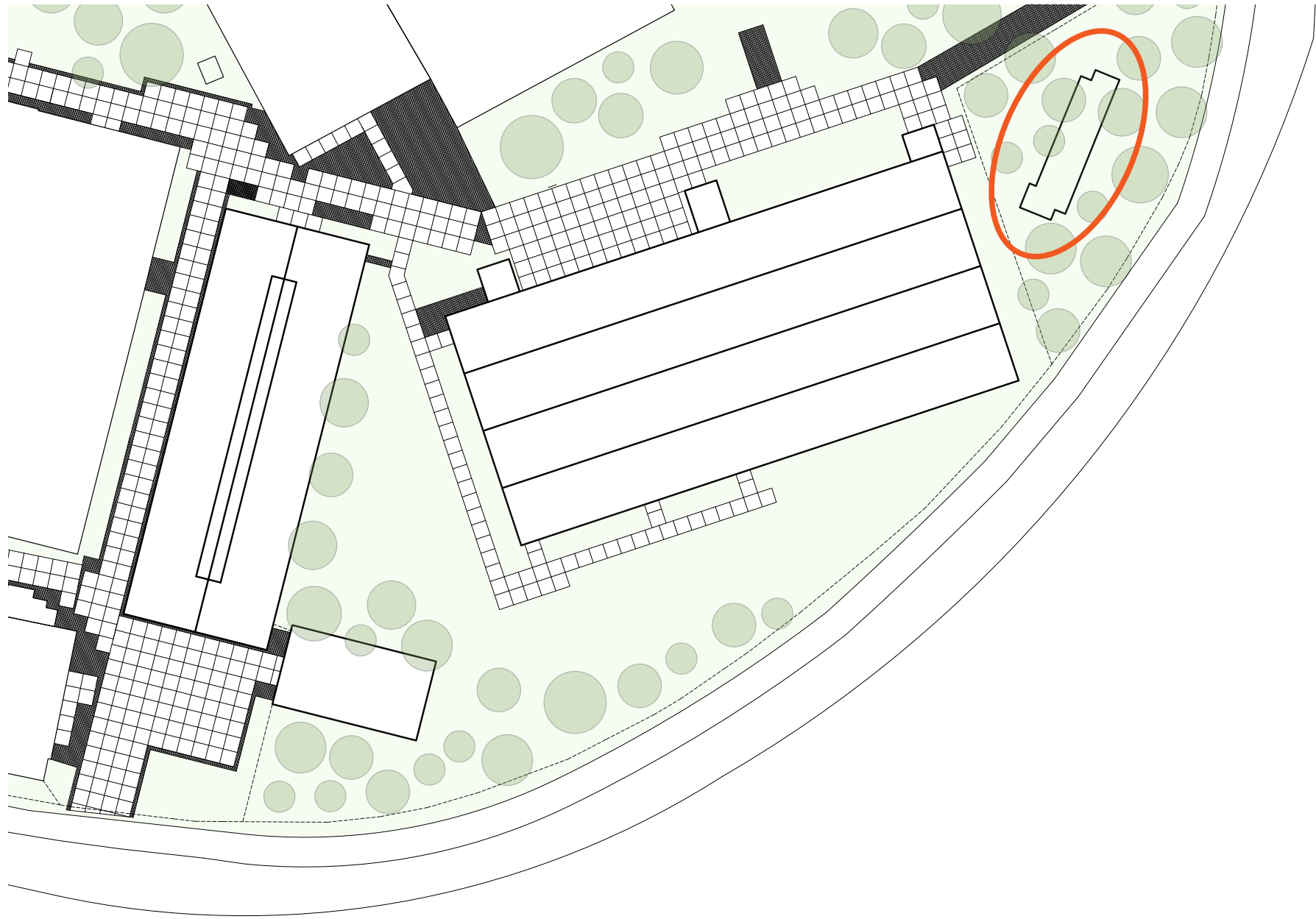

Shelter - essence

A hidden relict from the past

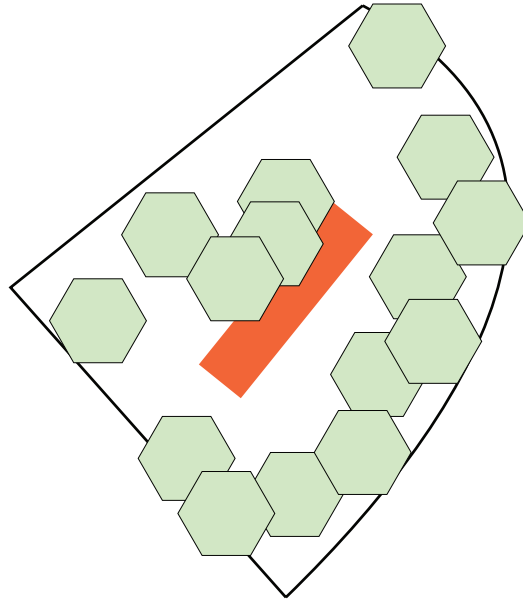

Hidden/isolated

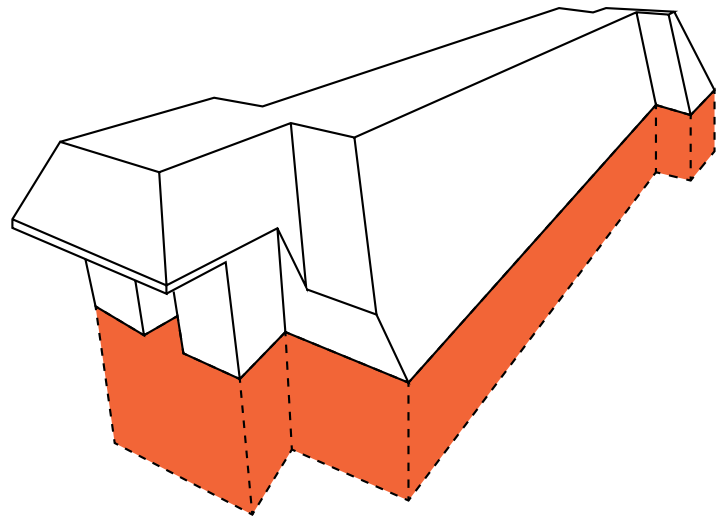

Partly underground

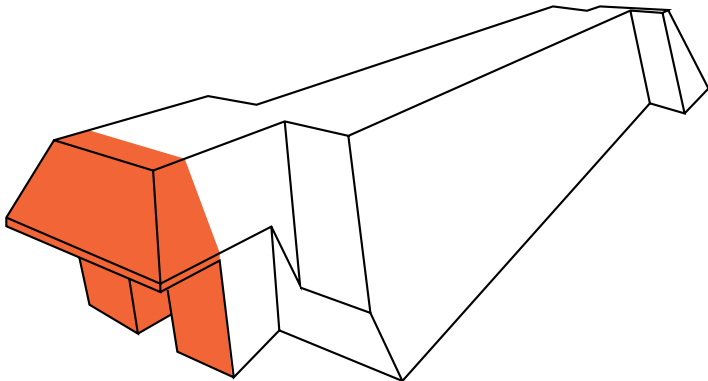

Emphasized entrance

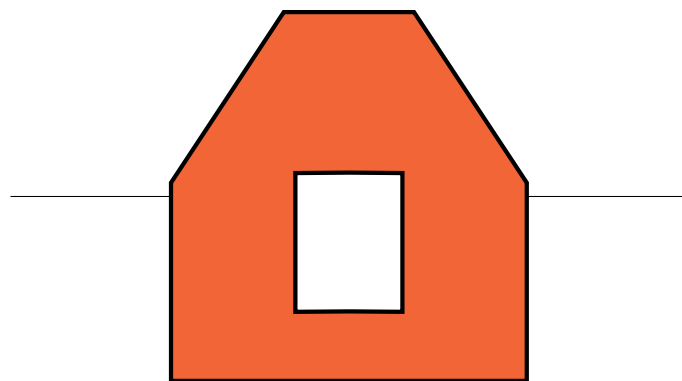

Closed monolithic mass

Ensemble - overview

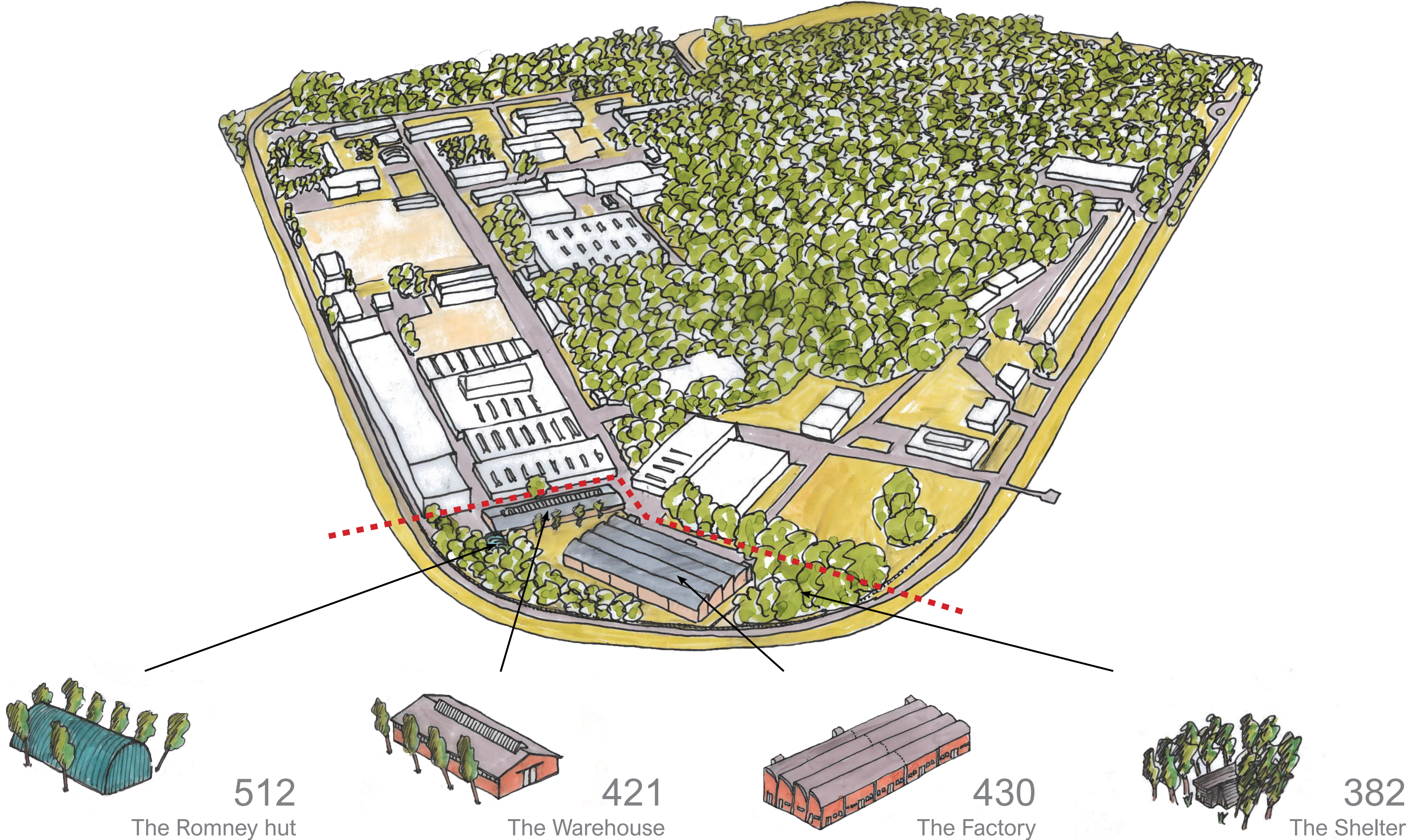

Ensemble - views

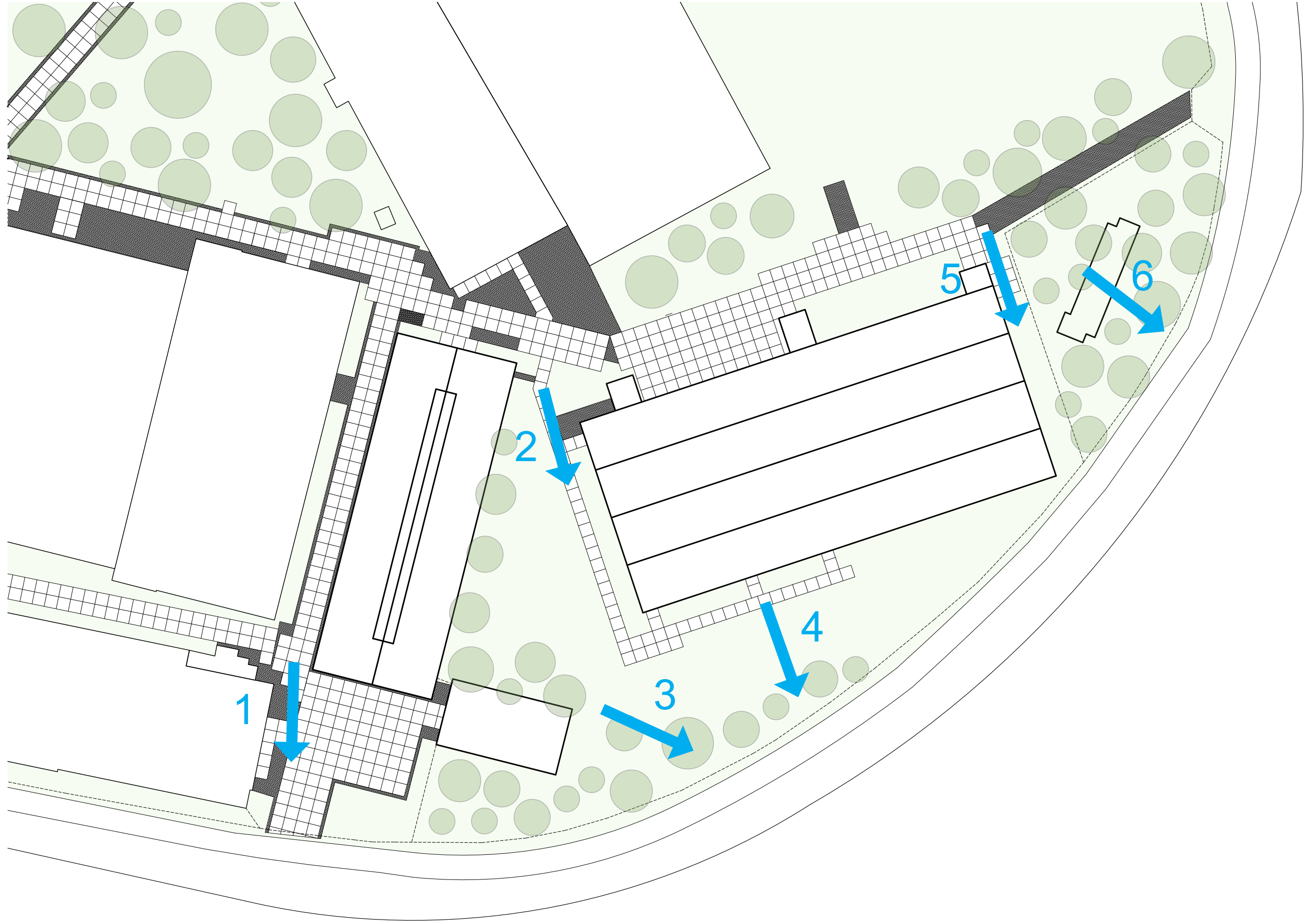

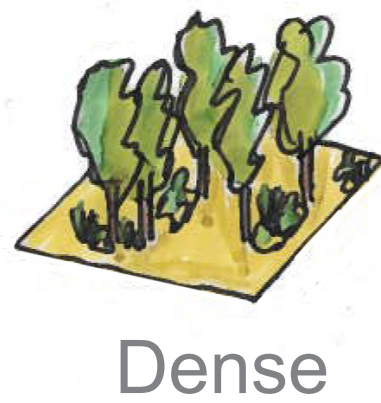
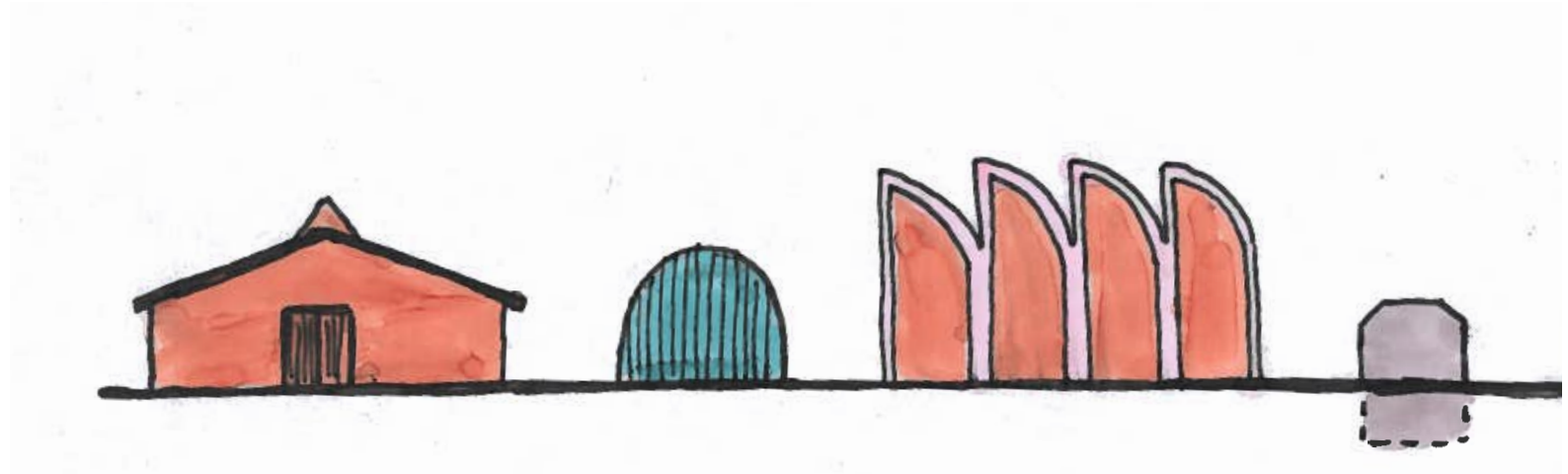
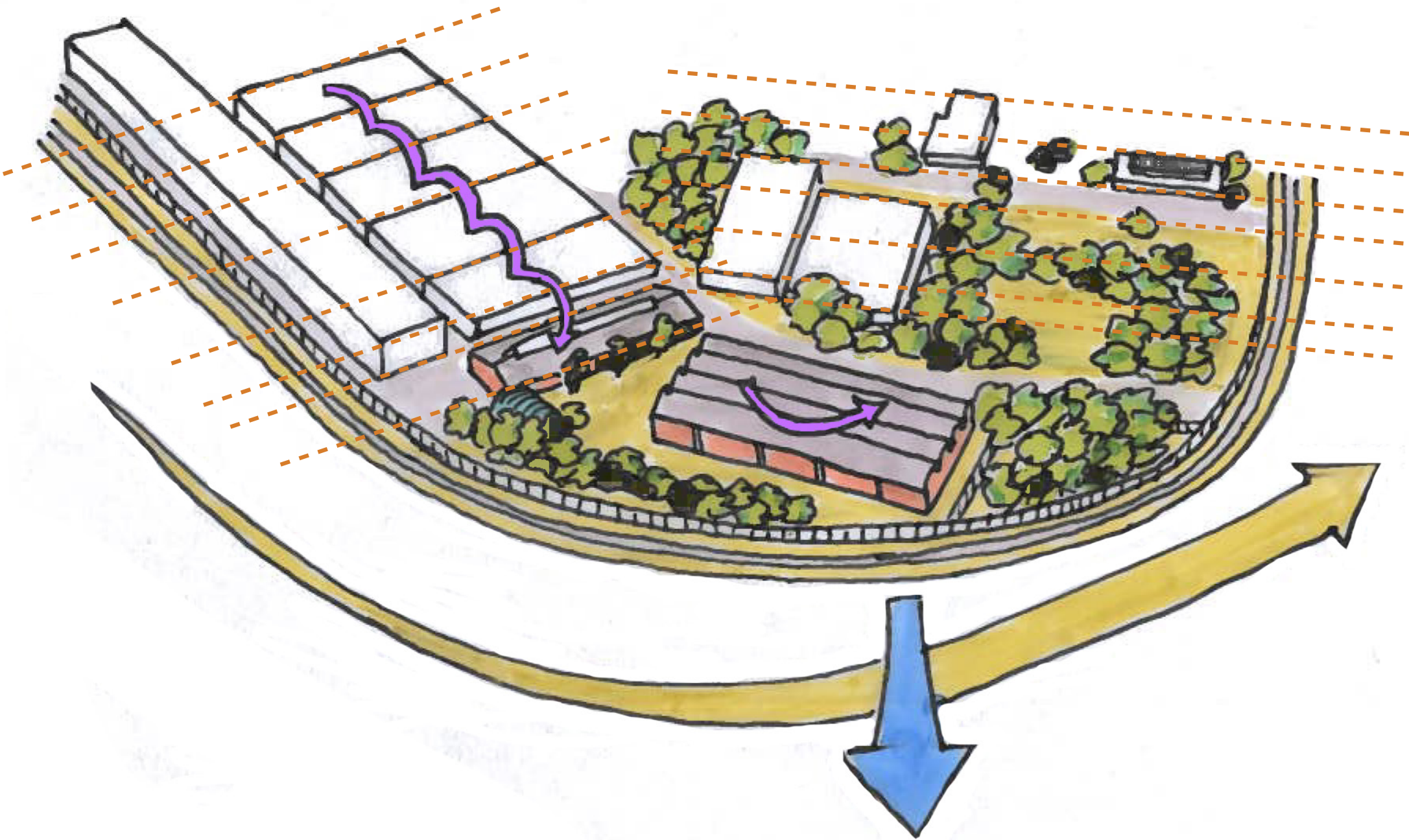

vs



Dense

Open



vs

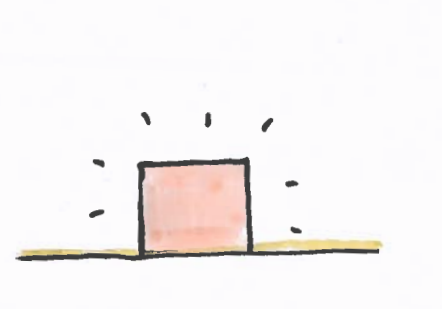

Hidden

Exposed

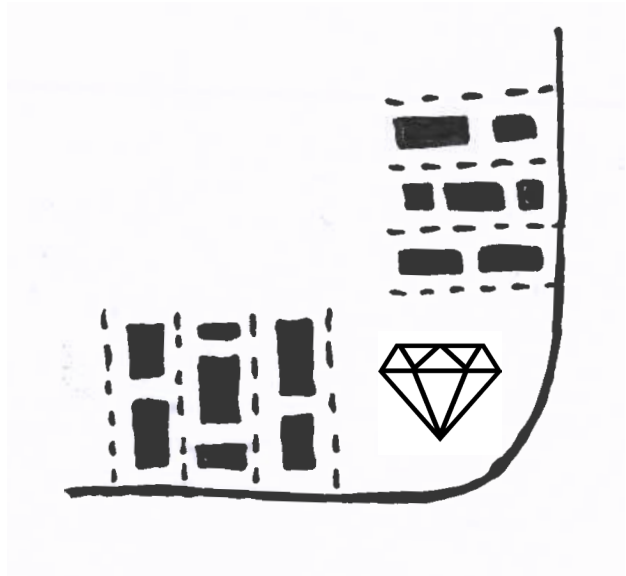
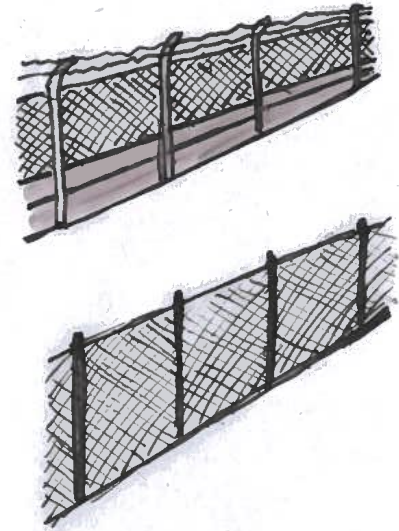
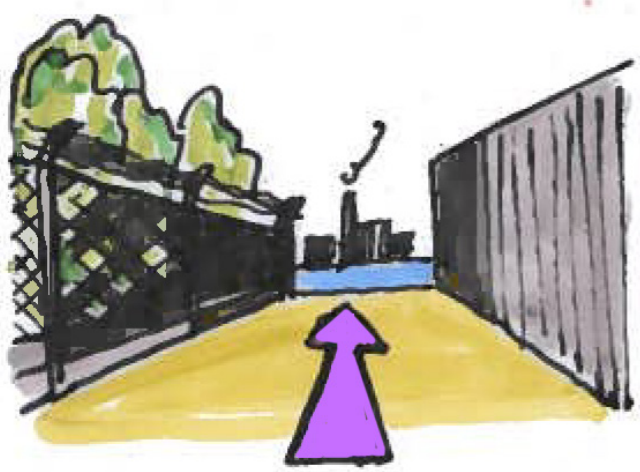



A ~~military~~ production estate

Problem



Example: in NL 10.4 million kilos of electrical devices and textiles are thrown away weekly!

Source: www.sire.nl

Fascination



LEEWARDER COURANT 4 wk

Nieuwe ambachtsschool wil Noorden veroveren

29 november 2012 • 15 mei 2015 • Archief



Nieuwe ambachtsschool wil Noorden veroveren

Nieuws: "Ambachtsschool terug? Eindelijk een verstandig plan!"



Nieuwe opleiding voor ambachten op Zwitsalterrein

Door [Natalie Polman](#) - 13 november 2017

Sinds kort is het Ambachtsplein, een opleiding voor ambachten gevestigd in de voormalige werkplaats van het Zwitsalterrein.

Vanaf dag één in een bedrijf

Het Ambachtsplein is in het klein in Nijmegen ontstaan als het 'Leermeester - Gezel concept'. De opzet was om jongeren vanaf dag één in een bedrijf te laten starten. Inmiddels is het Ambachtsplein actief op verschillende locaties, waaronder dus in Apeldoorn.

Drie opleidingen

De organisatie biedt jongeren de kans om zich in eigen tempo te ontwikkelen in een vak. In Apeldoorn zijn drie verschillende opleidingen: Horeca, Bouwen en wonen (houtbewerking) en Mobiliteit (fietstechniek). Naast het leren van een vak leren jongeren ook 'werkemerskwaliteiten', zoals op tijd

Ambachtsschool helpt jonge mensen een mooi vak te leren

dinsdag 28 januari 2019 • 172 • 0



De Ambachtsschool, gevestigd op de Museumwerf in Vreeswijk, werkt aan de herbouw van een middeleeuwse Stads kraan, die eeuwenlang op het Wed bij de Ganzenmarkt in Utrecht heeft gestaan. Over een paar jaar staat de nagebouwde kraan op de Bernsma Weerd. Het doel is om vooral jonge mensen, door een combinatie van werken en school, een mooi vak te leren. In het reguliere onderwijs is hier niet altijd gelegenheid voor.

Vaardigheden

Liesbeth Bouwhuis en Dimitri Marangou zijn beiden al zo'n twintig jaar bezig met dit soort projecten. Liesbeth: Tijdens de bouw van de kraan kunnen we twintig mensen opleiden. We gaan ook andere projecten oppakken, waardoor er plek is voor meer mensen. Binnen anderhalf jaar (kan ook korter zijn) bekwamen de leerlingen zich in bijvoorbeeld hout- of metaalbewerking. Het aanleren van werknemersvaardigheden is ook belangrijk voor het vinden van een baan na dit traject.

Ook voor volwassenen

Oversig is de Ambachtsschool, waarin de gemeente participeert, er niet alleen voor jonge mensen. Ook mensen boven de 27 zijn zeer welkom. De Museumwerf is een hele mooie locatie met veel mogelijkheden om met een mooi project te werken. Het geeft werkervaring en iedereen leert er veel van. We zijn erin verweven van de werkplaats en de eerste houtbewerkingen.

Direct dit a

Het Metzeld Friesland, O

De ambacht de 16 en 28 schilder en theoretisch

Centraal in dependance



Het plan van opleidingsdirecteur Frank Knotter, om de ambachtsschool op één reactie na, is eigenlijk iedereen enthousiast. "Vakmanschap begint met een goede leeromgeving. De ambachtsschool heeft hiervoor eenvoudige deze week zijn spraakmakende plannen: de oude ambachtsschool wordt omgebouwd tot een leeromgeving voor jongeren. Met als gevolg dat tal van potentiële bouwtaalenten nooit voor de deur van de ambachtsschool komen. Met als gevolg dat tal van potentiële bouwtaalenten nooit voor de deur van de ambachtsschool komen. Met als gevolg dat tal van potentiële bouwtaalenten nooit voor de deur van de ambachtsschool komen.

...entvouwde deze week zijn spraakmakende plannen: de oude ambachtsschool wordt omgebouwd tot een leeromgeving voor jongeren. Met als gevolg dat tal van potentiële bouwtaalenten nooit voor de deur van de ambachtsschool komen.

...eog. Met als gevolg dat tal van potentiële bouwtaalenten nooit voor de deur van de ambachtsschool komen. Met als gevolg dat tal van potentiële bouwtaalenten nooit voor de deur van de ambachtsschool komen.

...ij een ouderwetse vakopleiding", reageert Evert van der Wilt op de Facet van de ambachtsschool. Hij ziet de terugkeer van de ambachtsschool wel zitten. "Goed dat de ambachtsschool terugkomt. Het is een goede zaak. Het is een goede zaak. Het is een goede zaak.

...v directeur Frank lees je op de Cobouw website. Klik [hier!](#)

**WAARDEER HET
REPEREER HET**
SRE

**WAARDEER HET
REPEREER HET**
SRE

**WAARDEER HET
REPEREER HET**
SRE

**WAARDEER HET
REPEREER HET**
SRE

Source: www.sire.nl



ron

Hij is vier dagen per week aan het werk bij de Ambachtsschool. "Ik wil interieurbouwer worden en hoop dat ik daarvoor nodig heb. Ik ben nu bezig met een gereedschapskist. In januari start ik één dag in de leerzame en oriënterende op de mogelijkheden die dit project hem bieden. "Ik wil een vak leren. Maar daar kom ik hier vast wel achter."

men

we mensen met goede begeleiding en opleiding allerlei vaardigheden aanleren zodat ze na deze opleiding werk kunnen vinden. Dat is prachtig en dankbaar werk. Je bouwt met z'n allen aan een heel concreet en meetbaar resultaat. Vooral jongeren die willen ontdekken waar hun talenten liggen en een vak willen leren, komen nemen op de werf. Dit is altijd goed voor de werf.

...? Mail naar info@stadskraan.nl of kom langs (maandag tot en met donderdag) op de Museumwerf.

Source: www.oestgeestercourant.nl

'Crafting for knowledge'

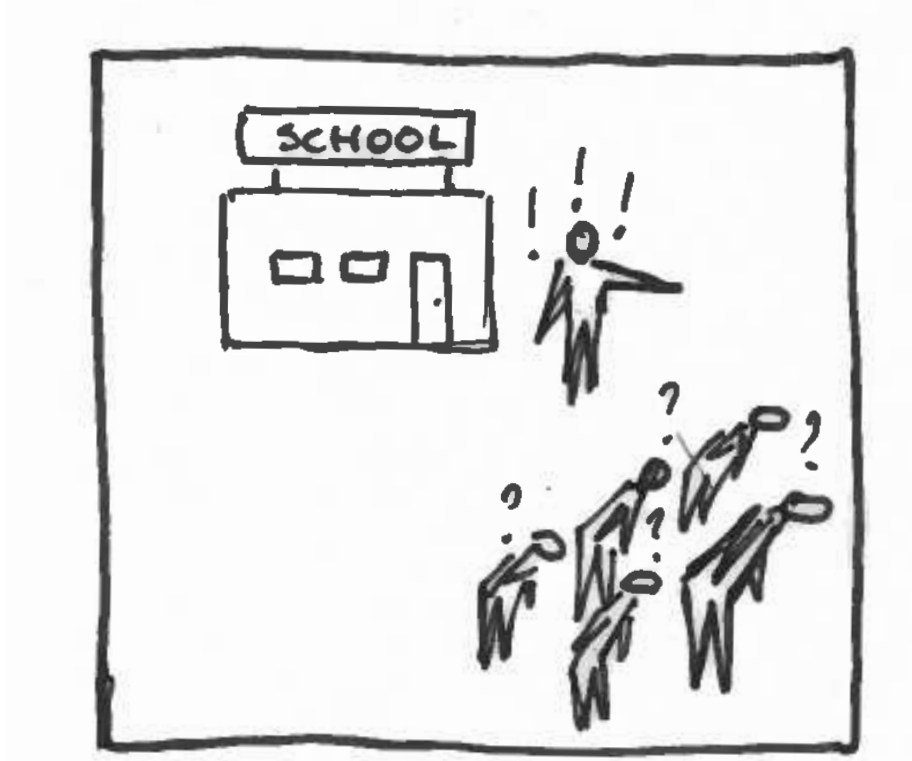

Underprivileged children

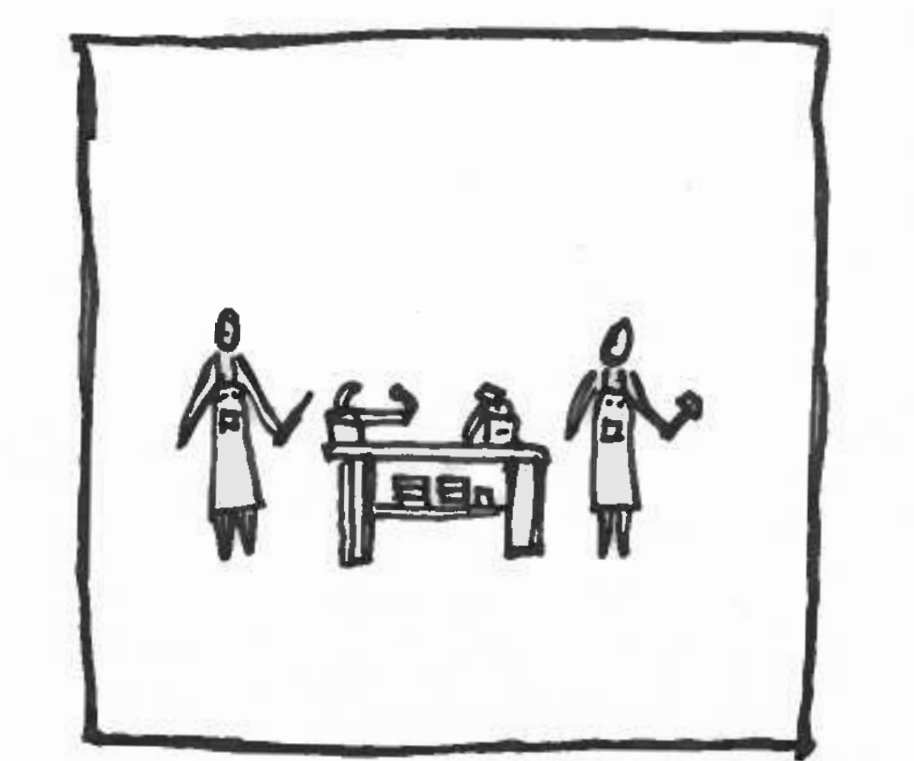

Professional craftsmen

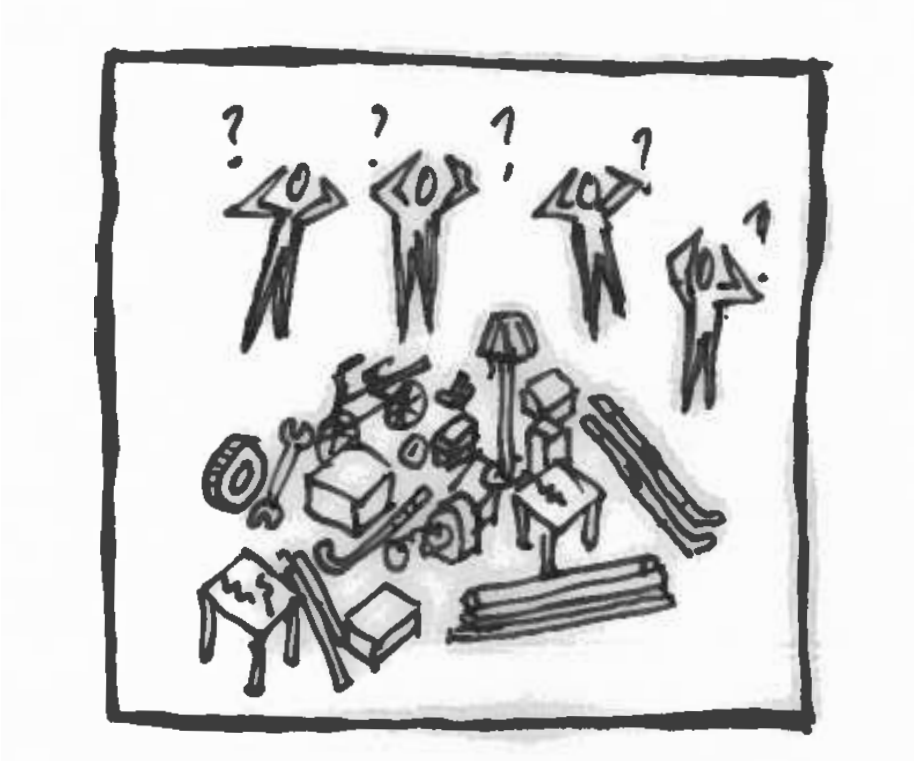

Public

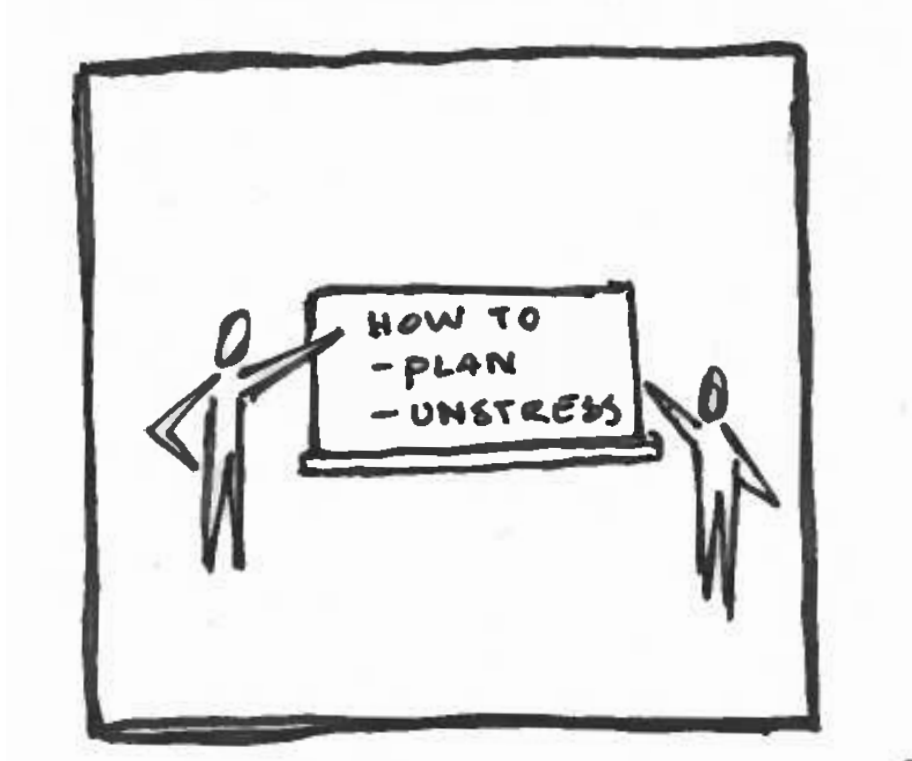

Educative/personal tutors

'Crafting for knowledge' - scenarios

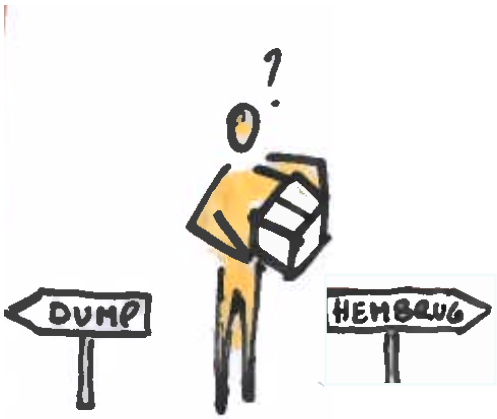

1



2

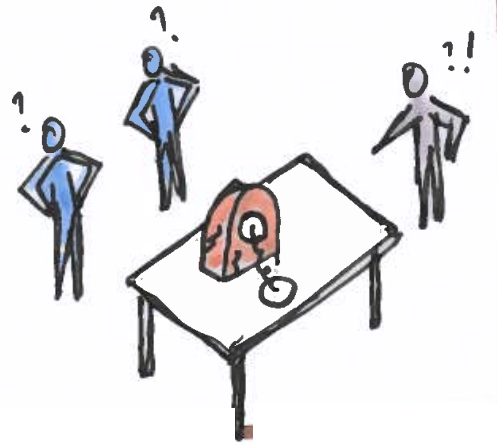

3

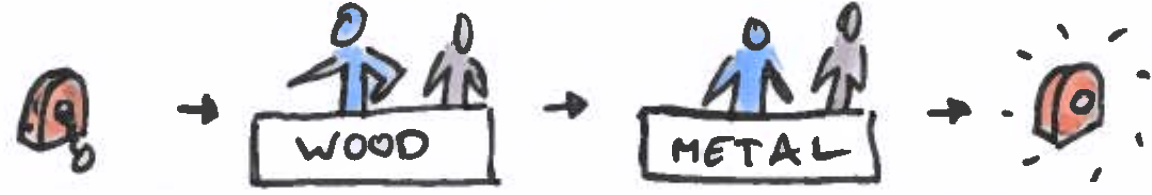

4



5



1



2



3



4



5

'Crafting for knowledge' - programme of requirements

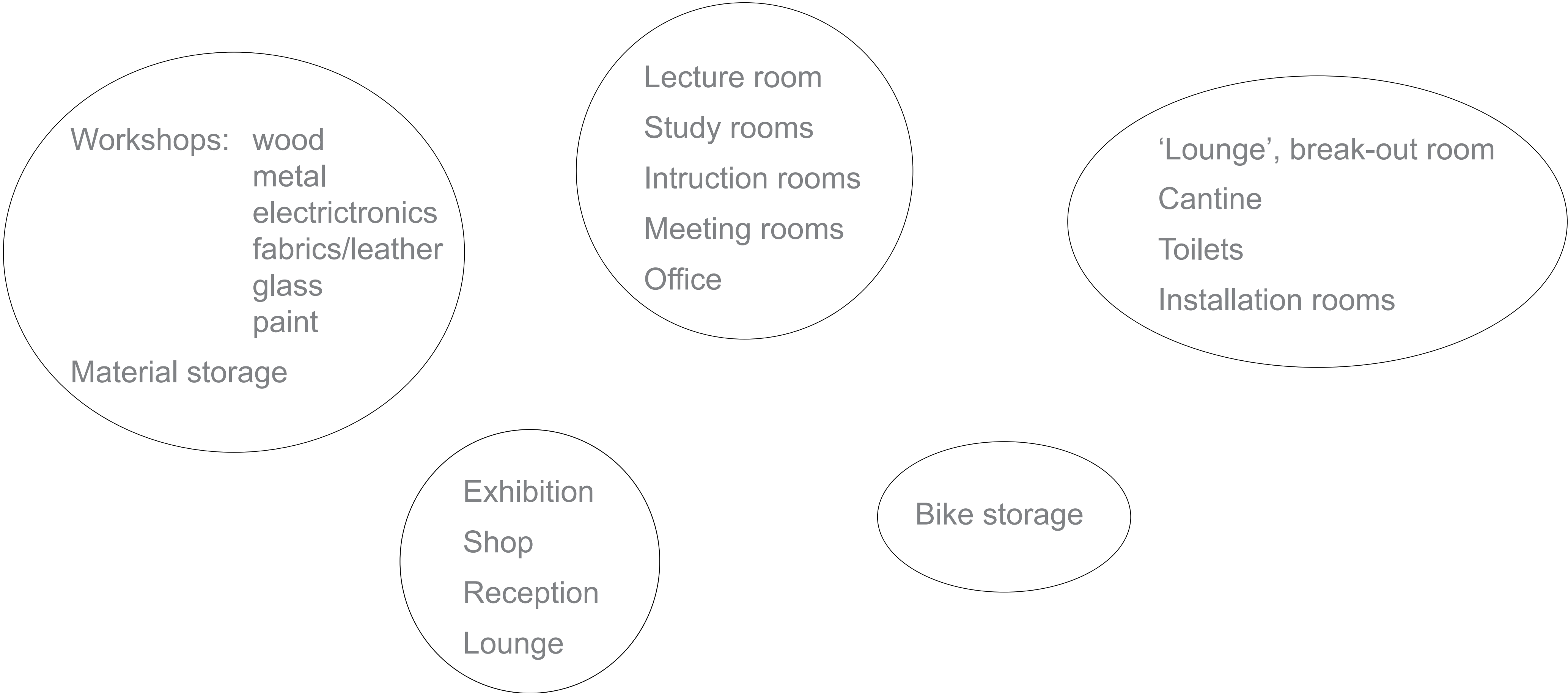

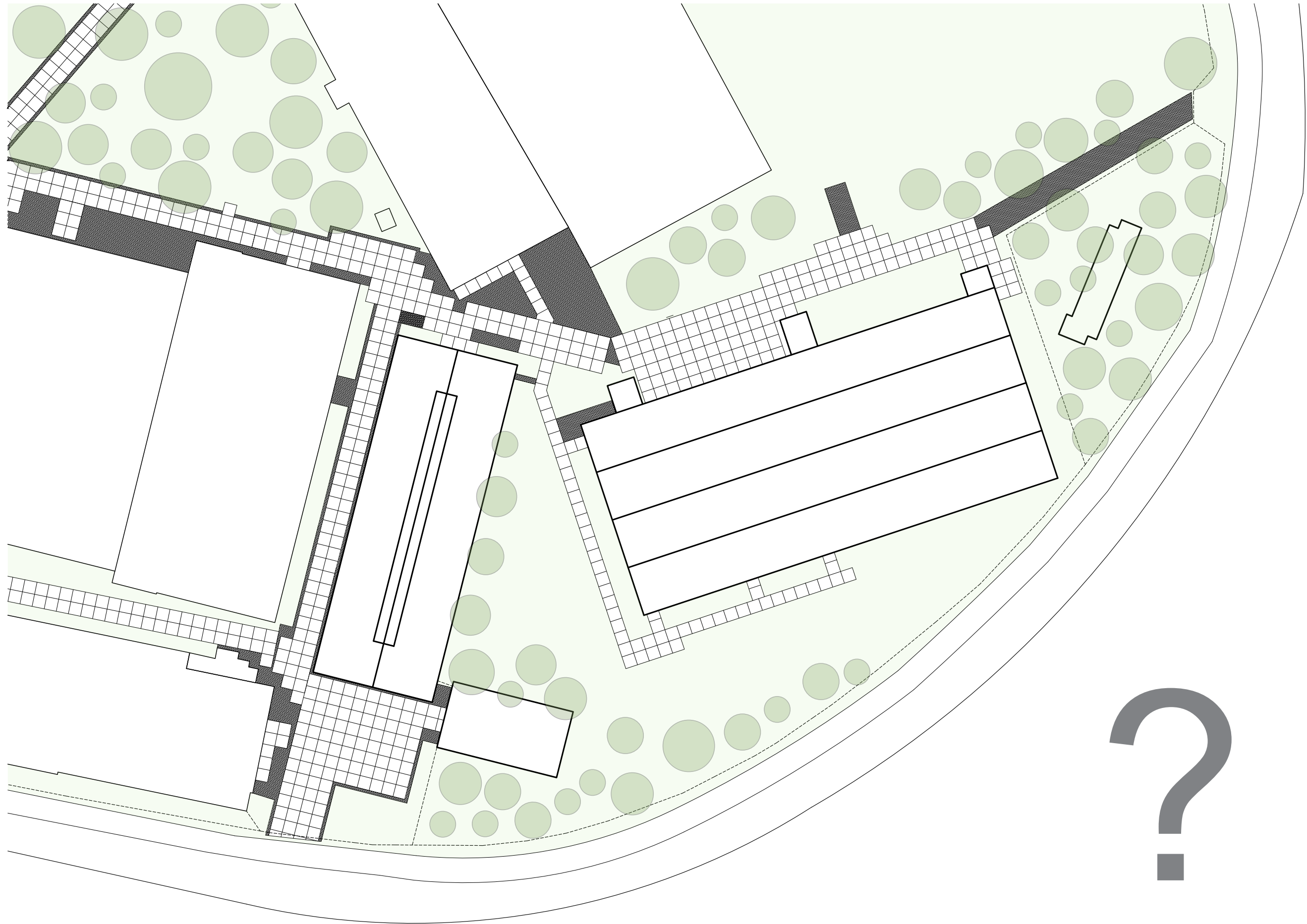

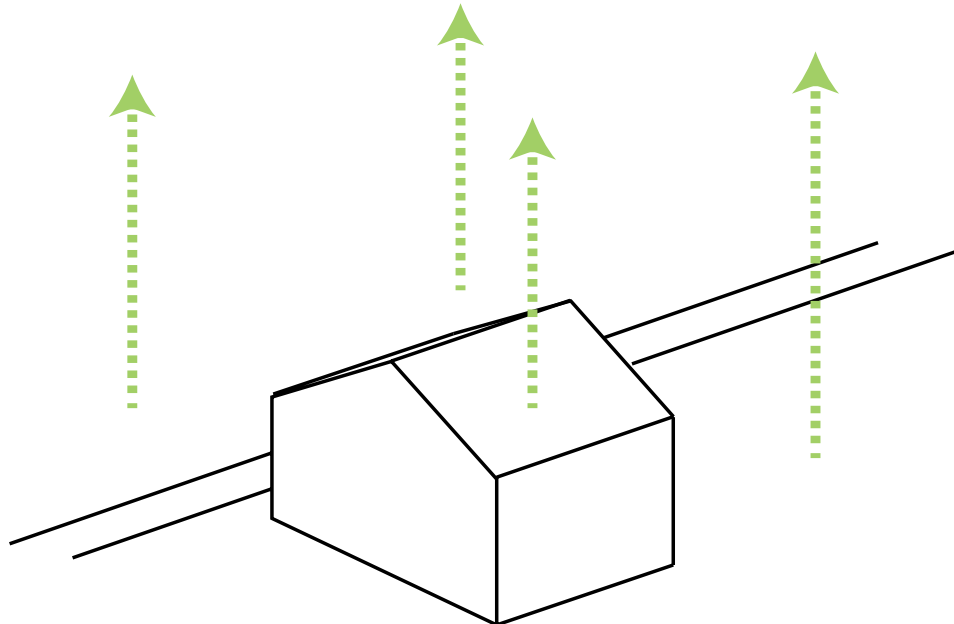

Use what's there

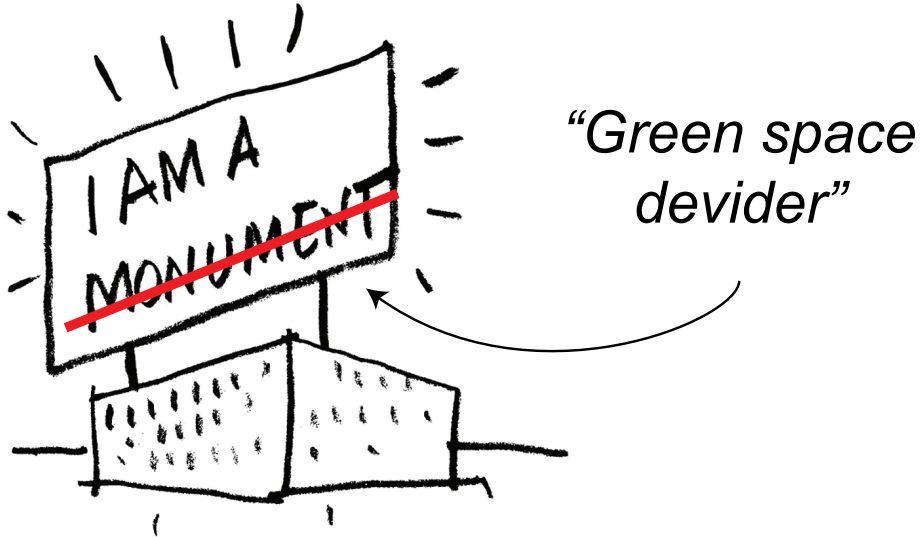

Essence

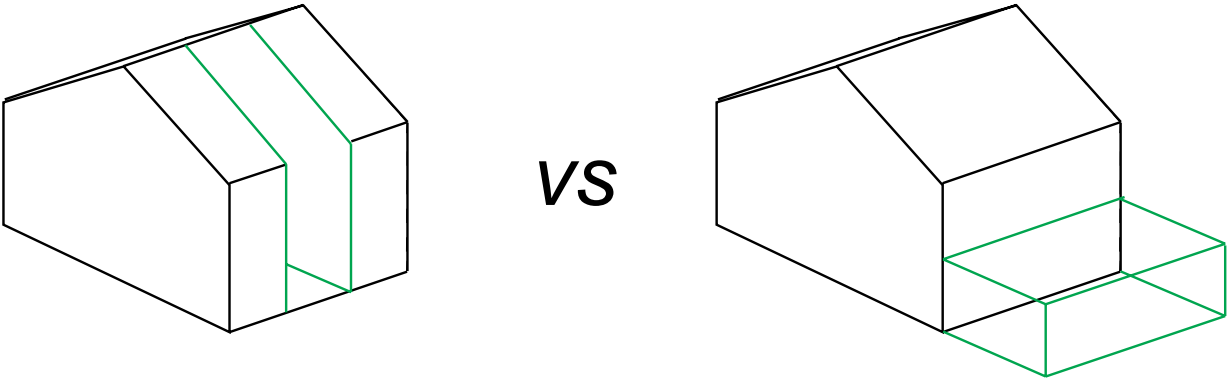

Types of interventions

Starting points

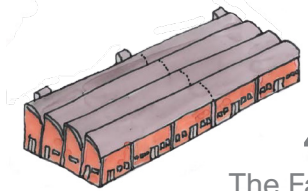

430
The Factory

Dominating individual

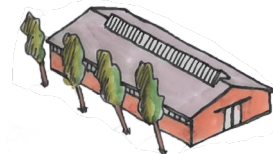

421
The Warehouse

Long storage building

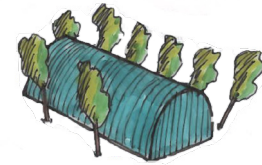

512
The Romney hut

Green space divider



382
The Shelter

Hidden relict from the past

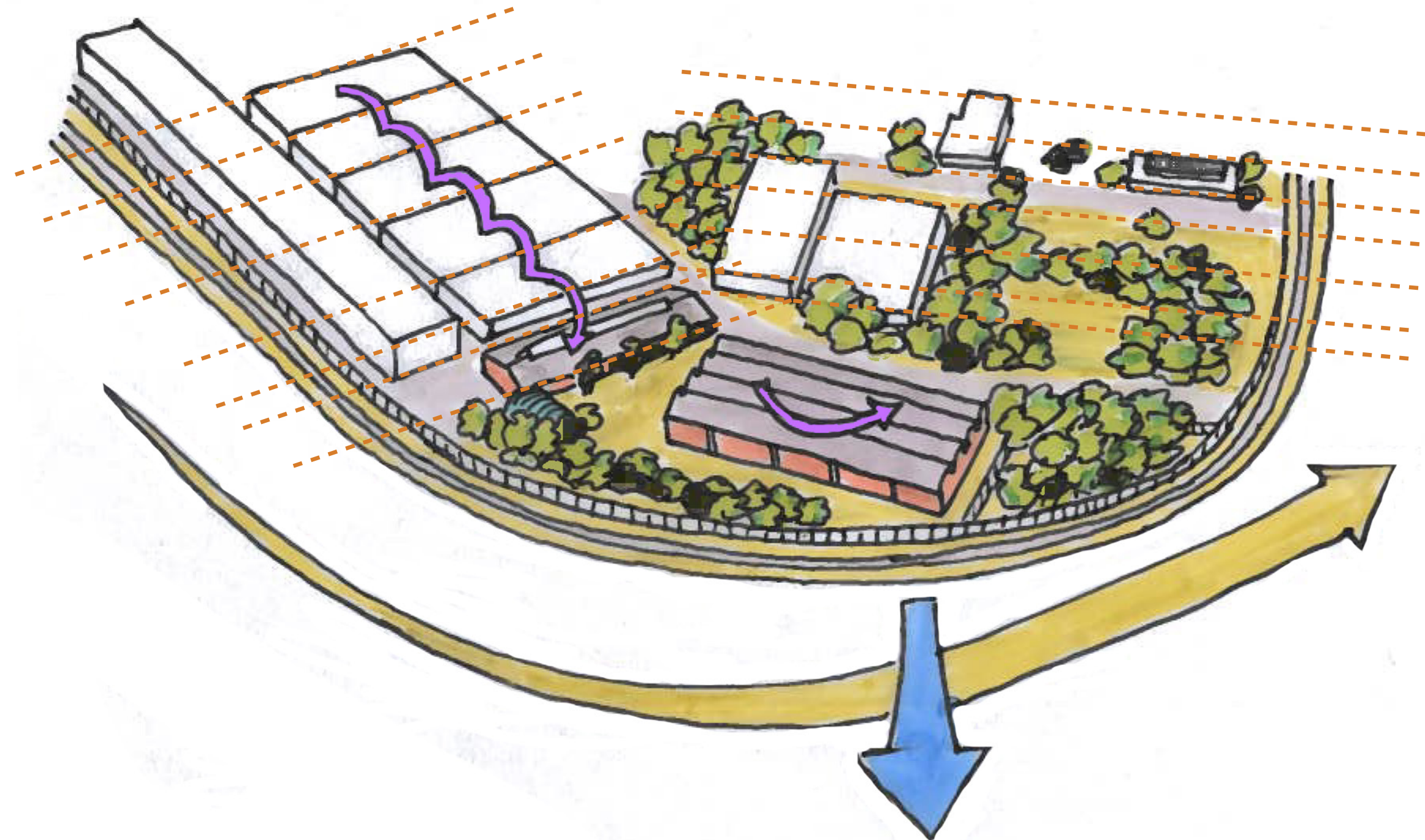

Starting points

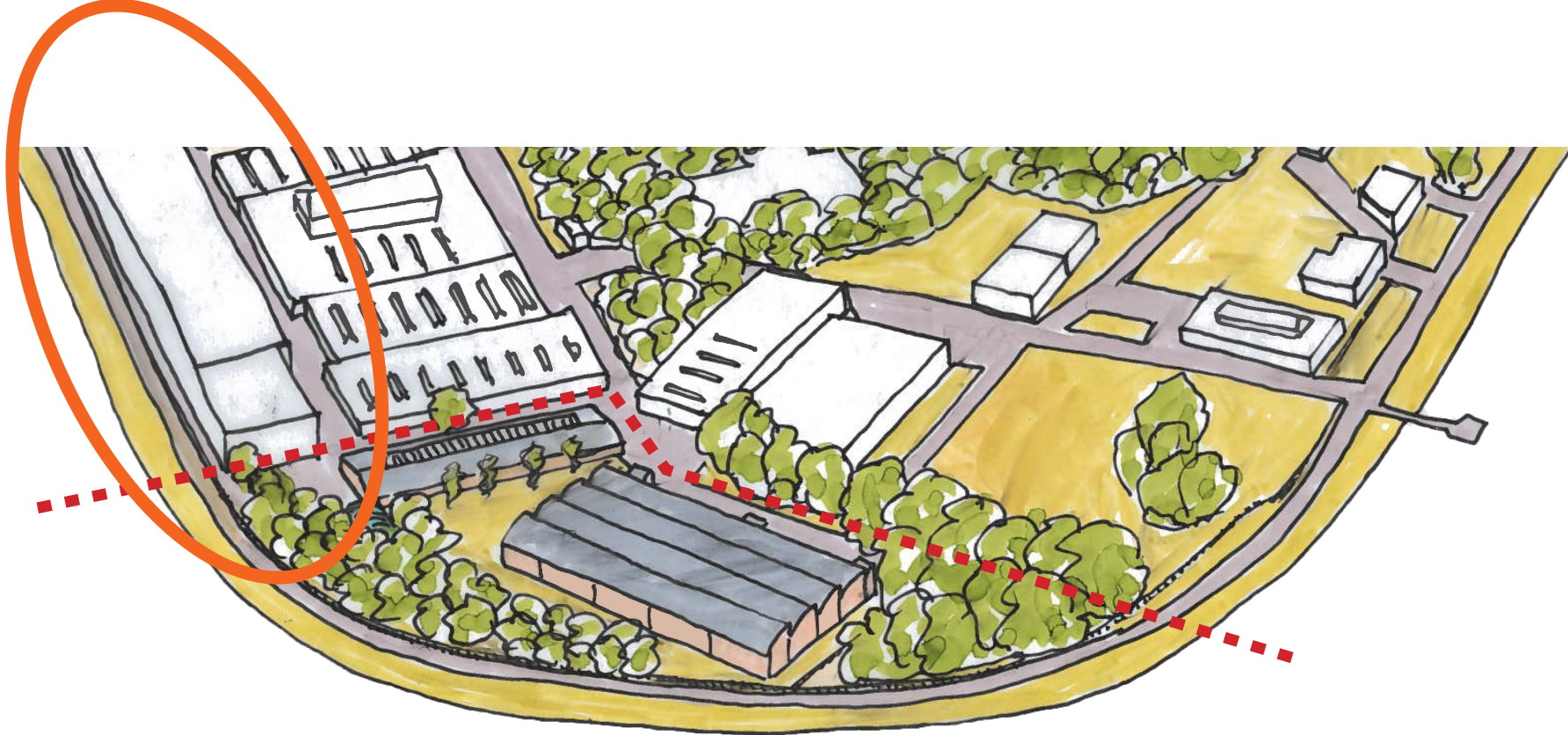

Source: www.zaanstad.nieuws.nl

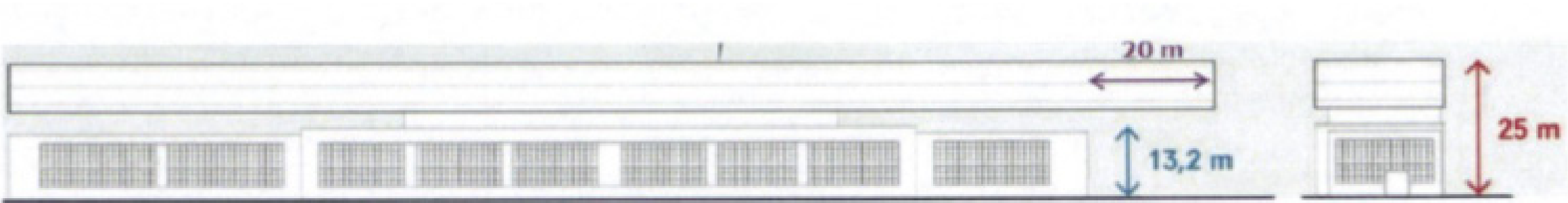

Source: www.deorkaan.nl

Ensemble - masterplan

Parking

Workshops (existing)

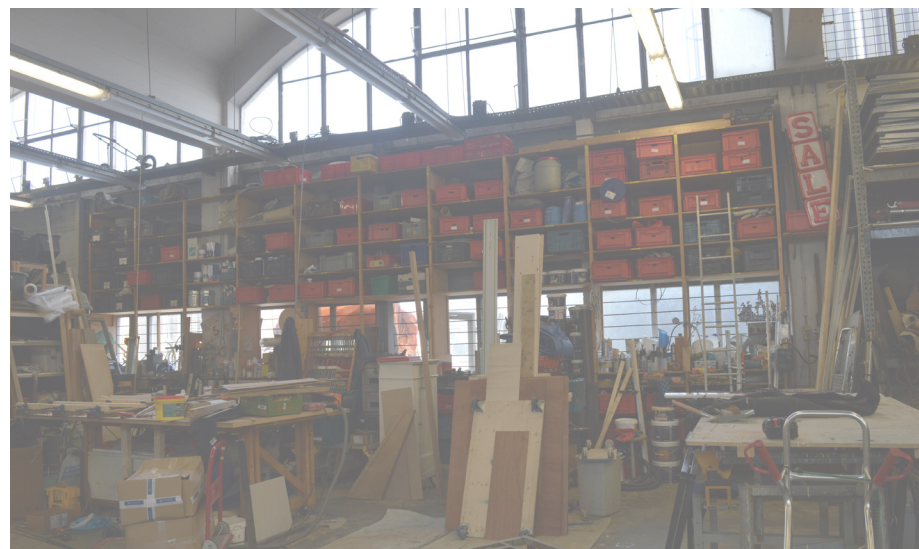

Events and horeca

Bike parking

OMA cultural centre



Permanent art installation

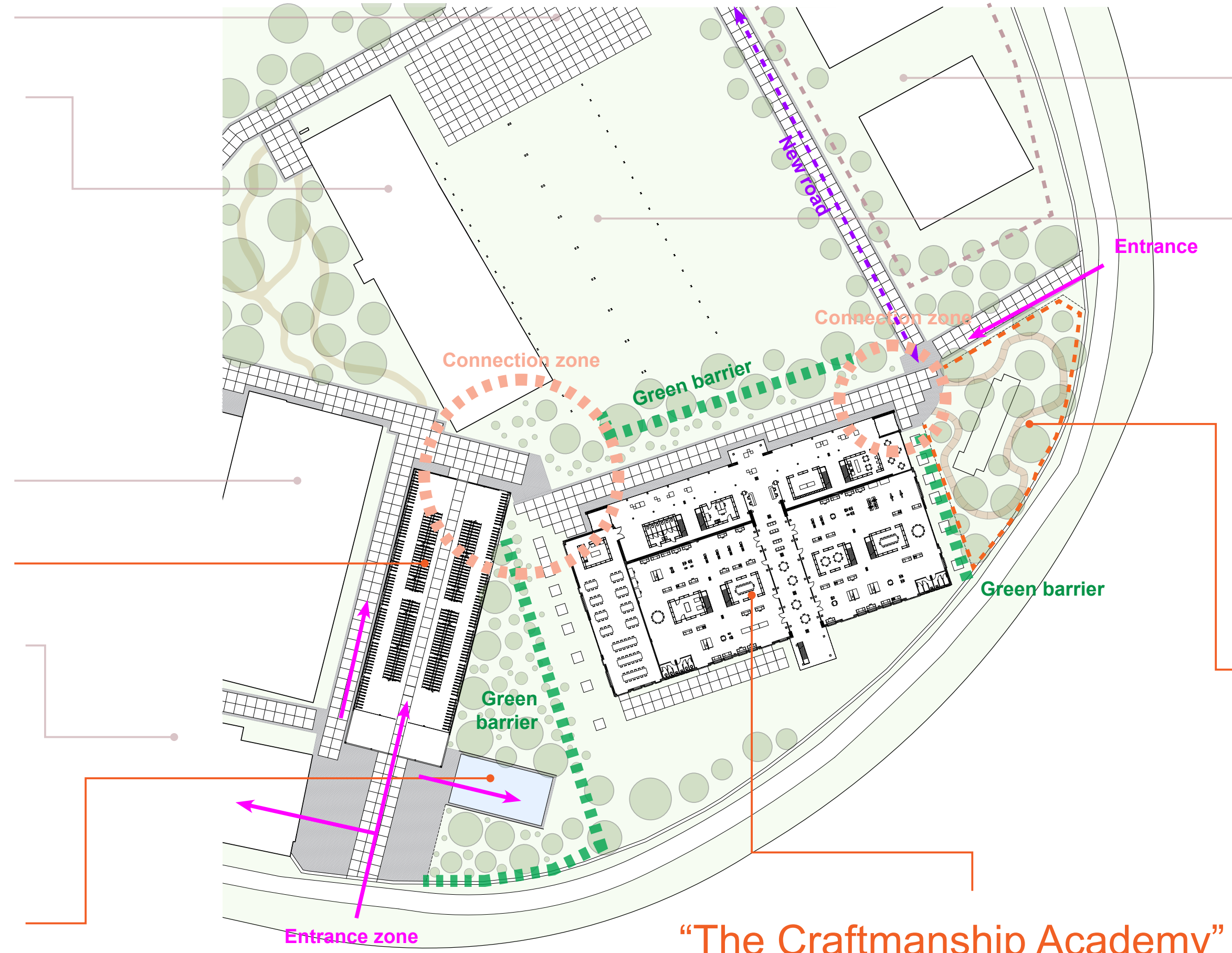

Residential

Outdoor event space



A calm walk with a view



“The Craftmanship Academy”

Ensemble - overview

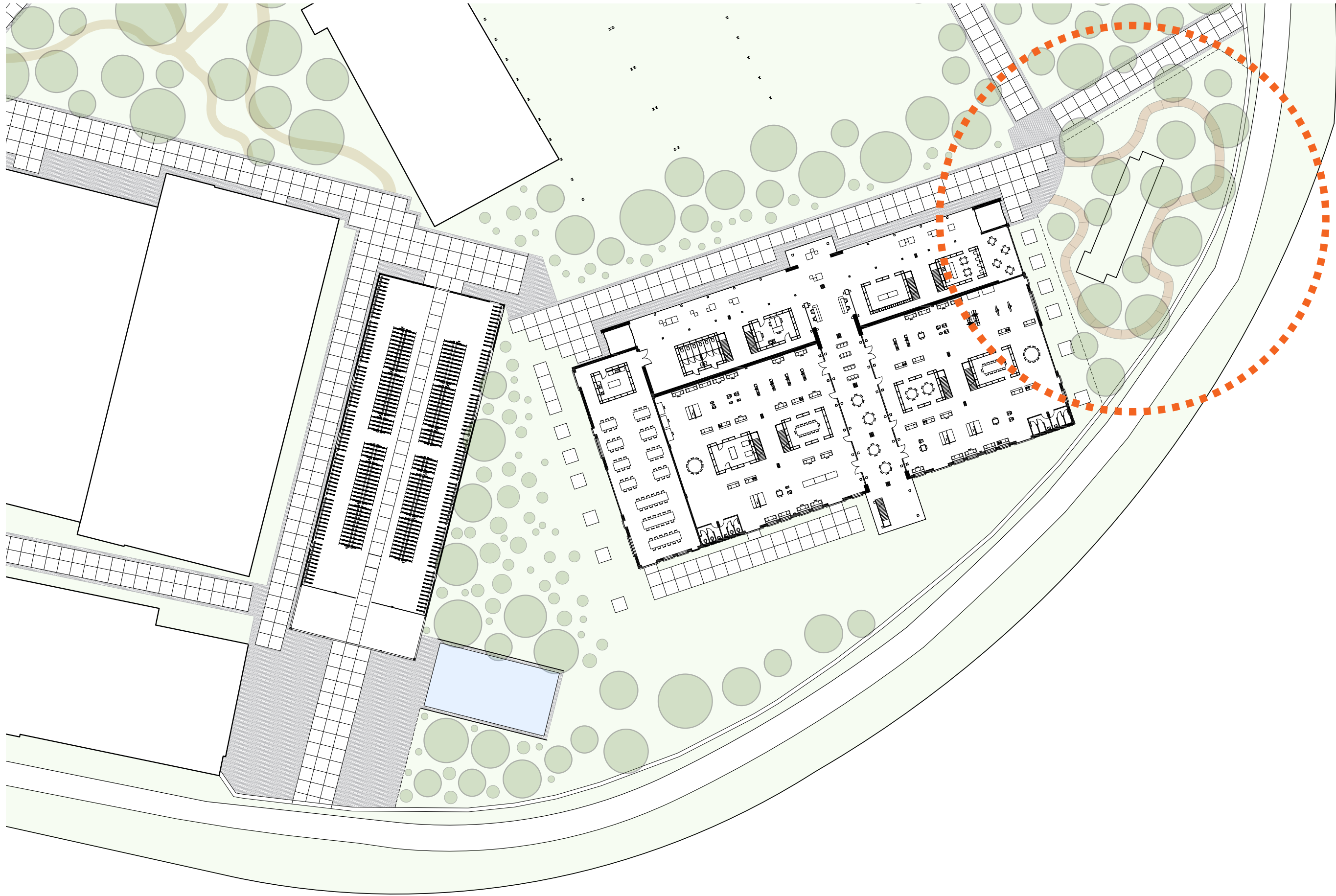

Shelter - starting points



Minimal disruption of green



Keep shelter untouched

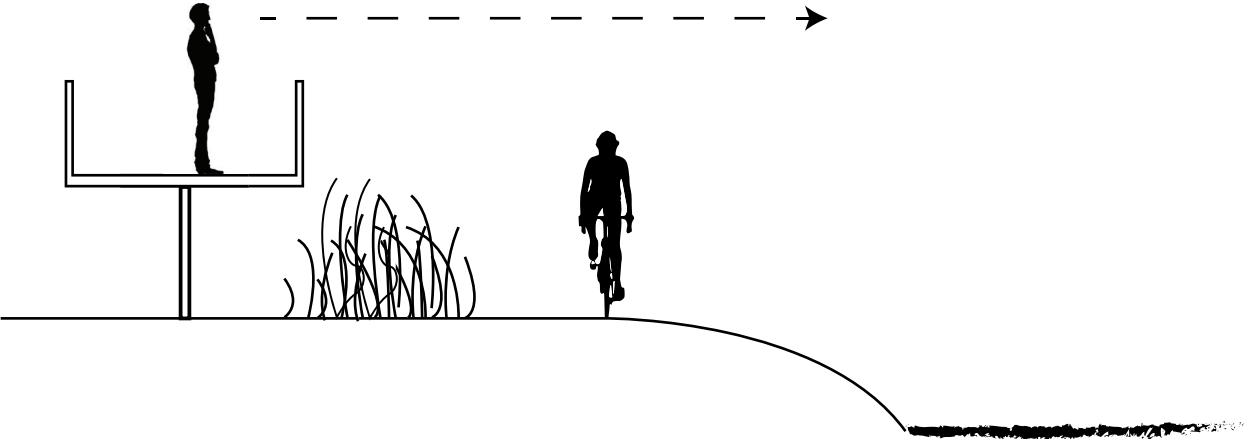

Unblocked views to the water

Shelter - context

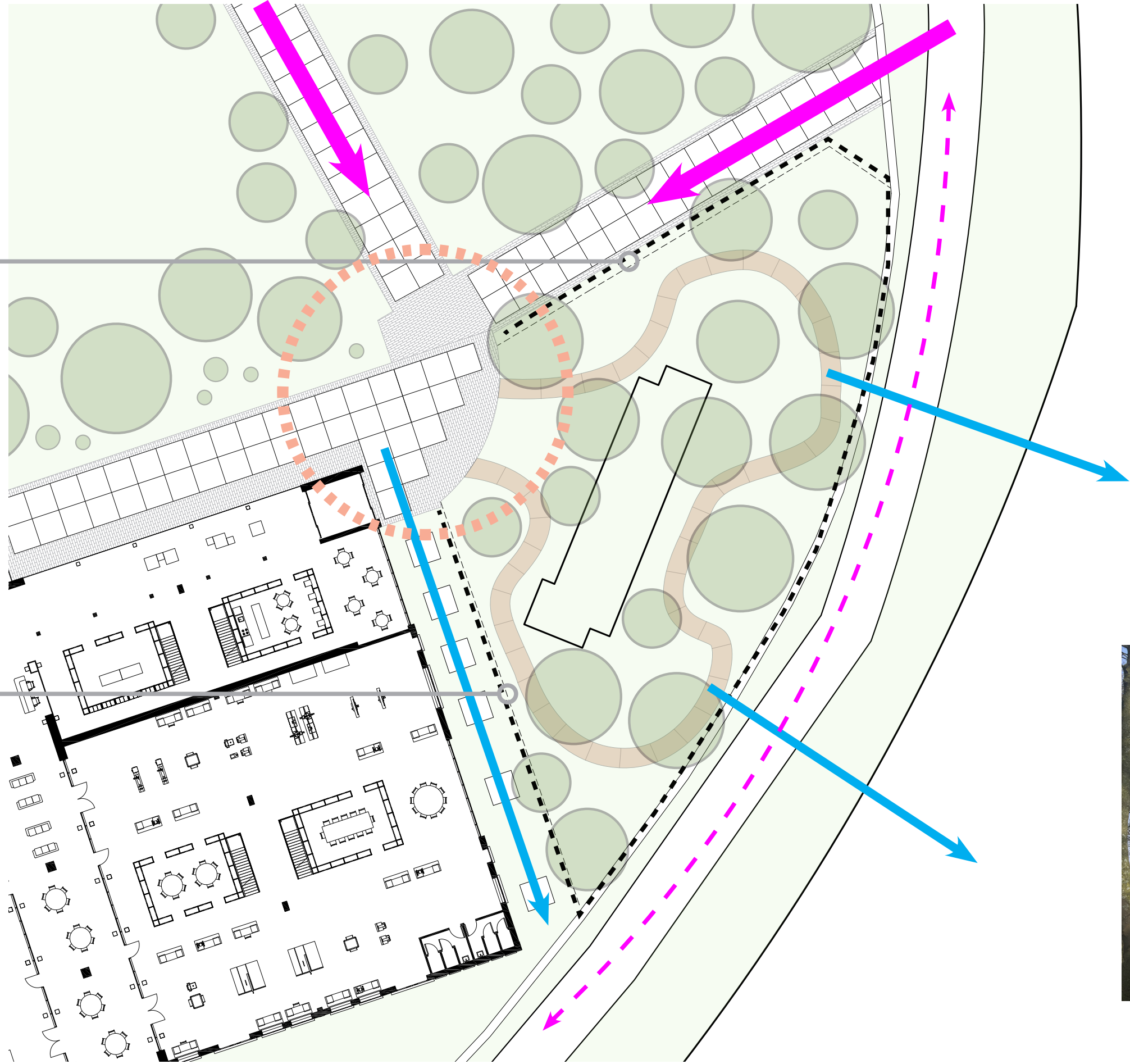

Shelter - section

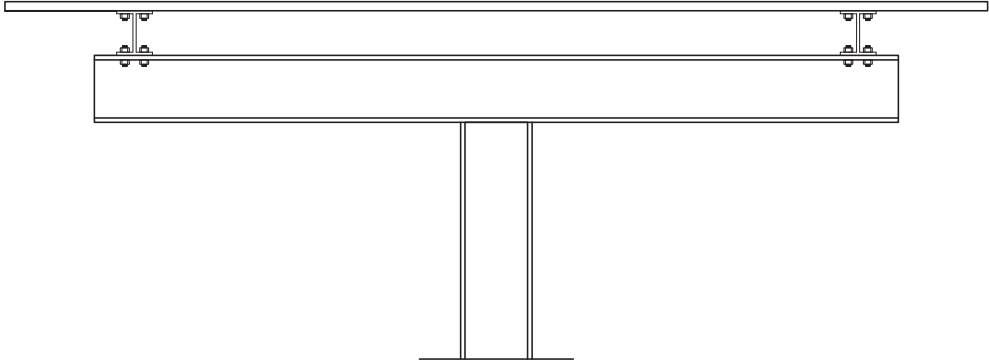
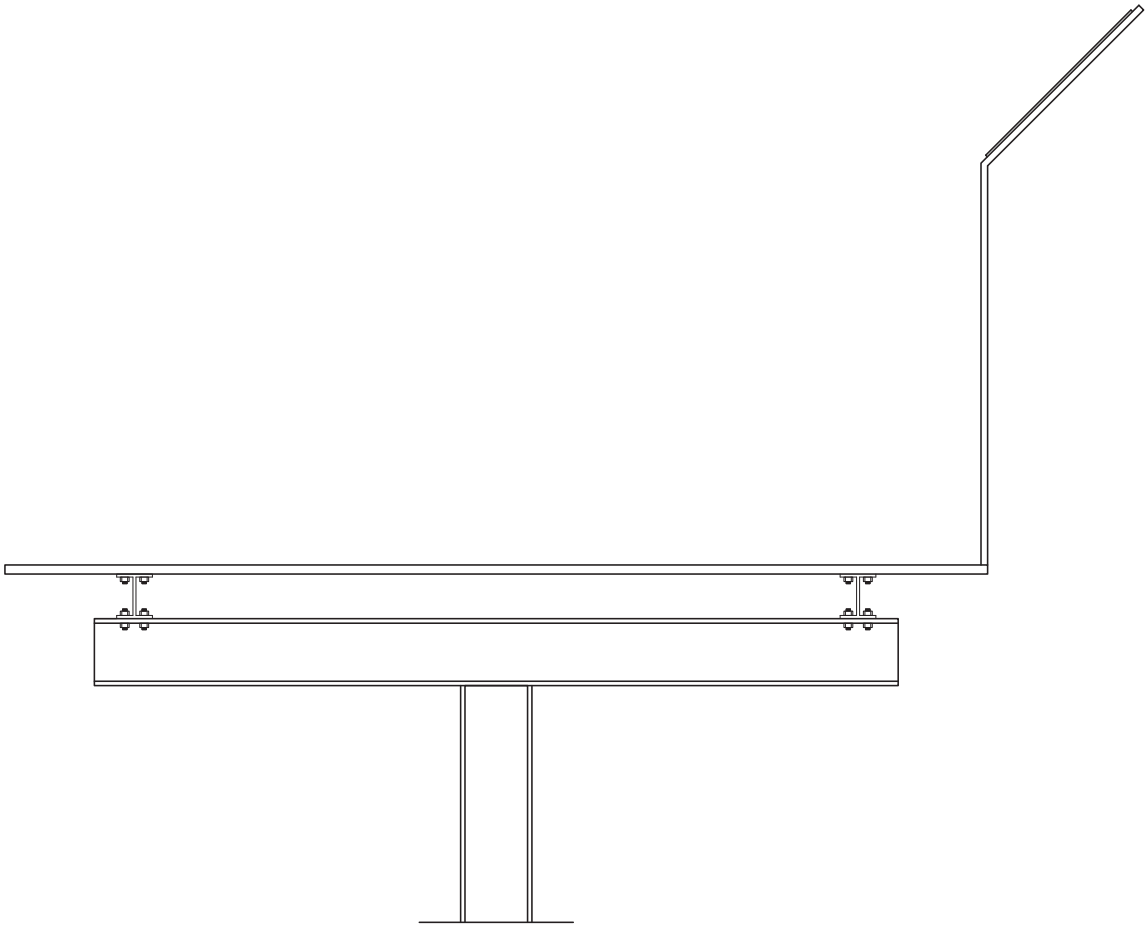
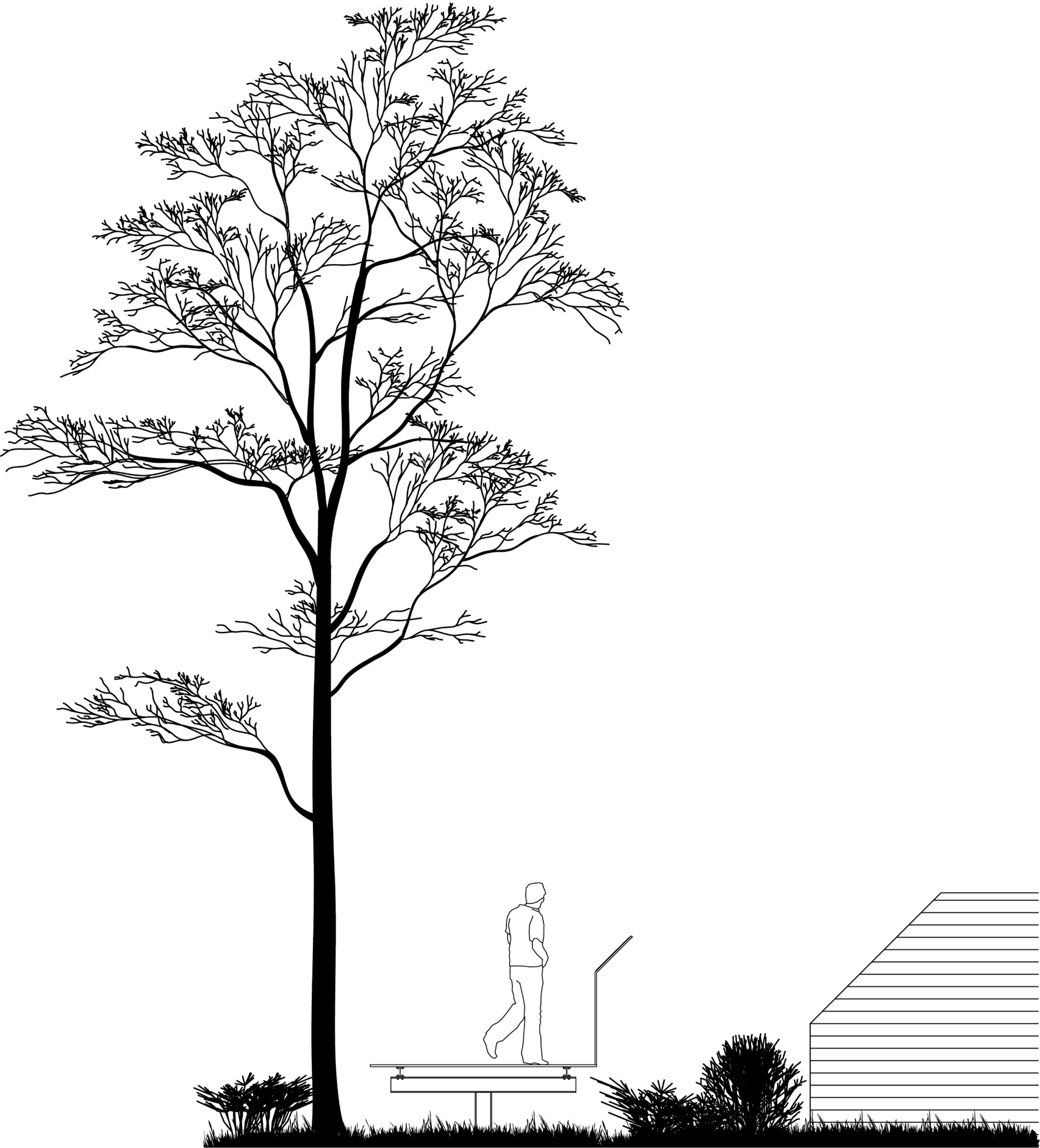

Shelter - impression



Ensemble - overview

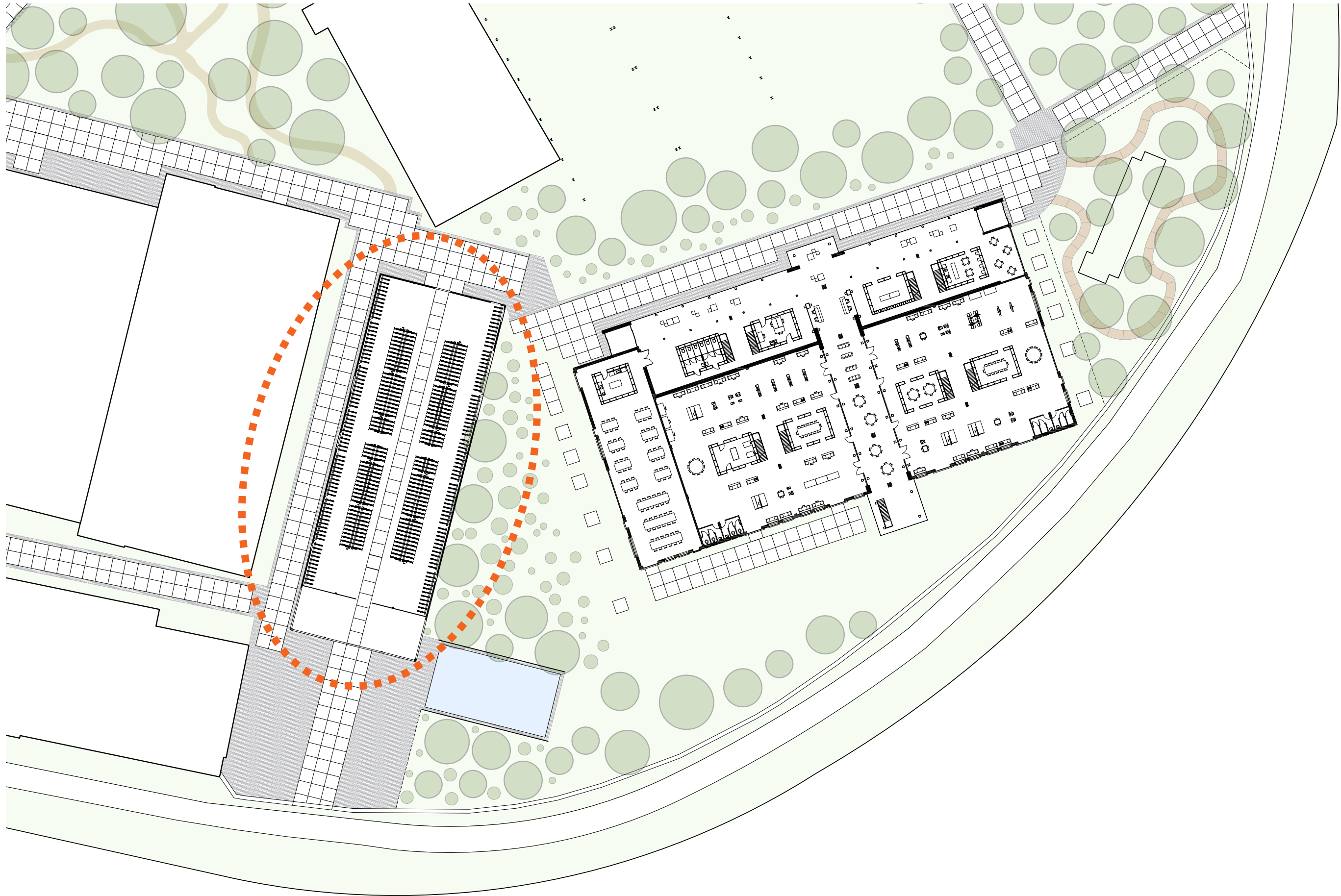

Bike Storage - starting points

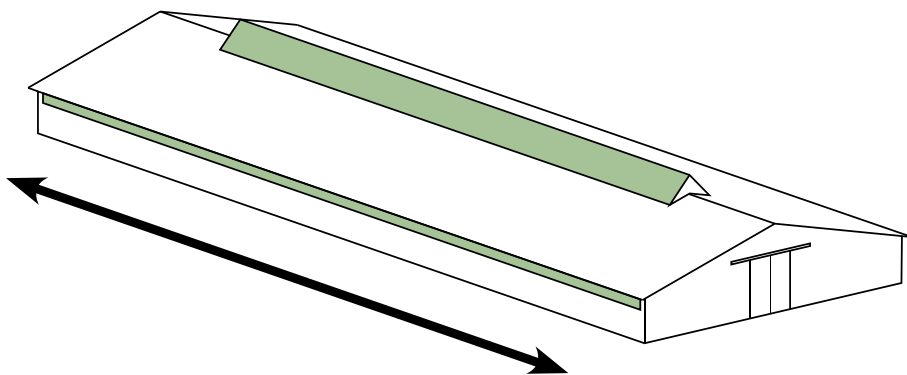

Length and horizontality

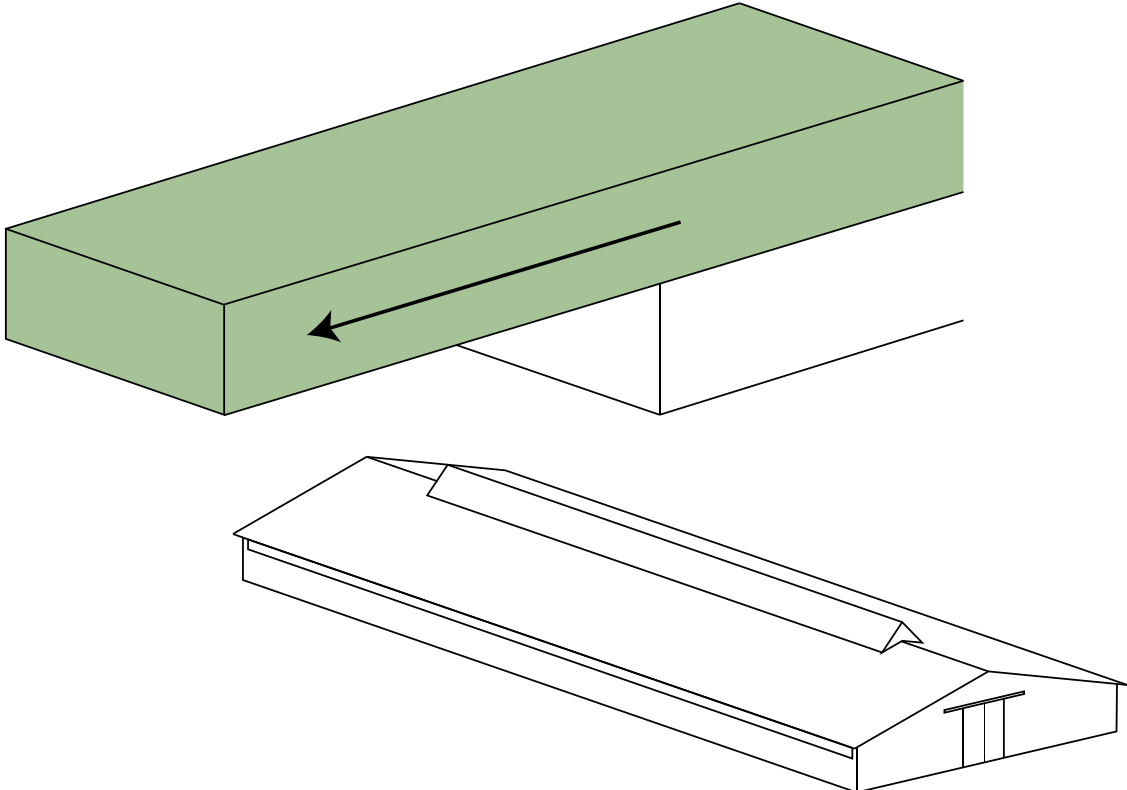

React to OMA

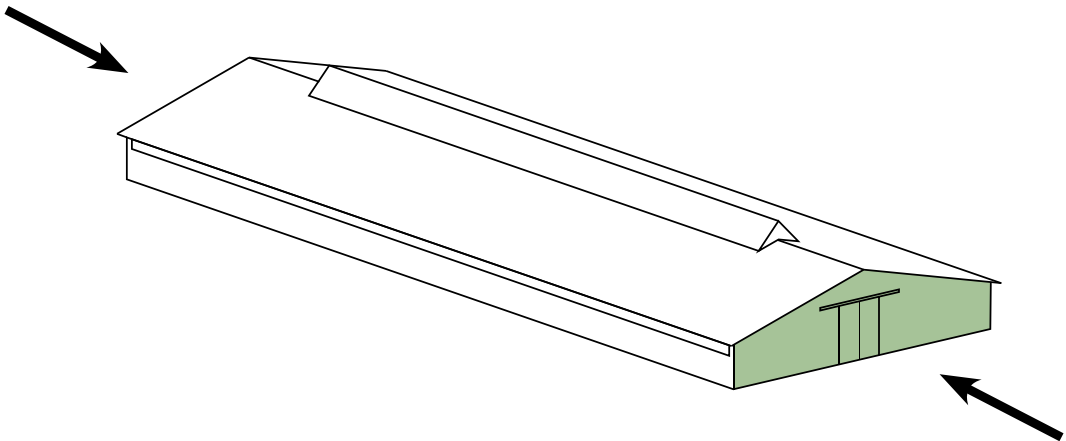

Emphasize main facades

Bike Storage - context

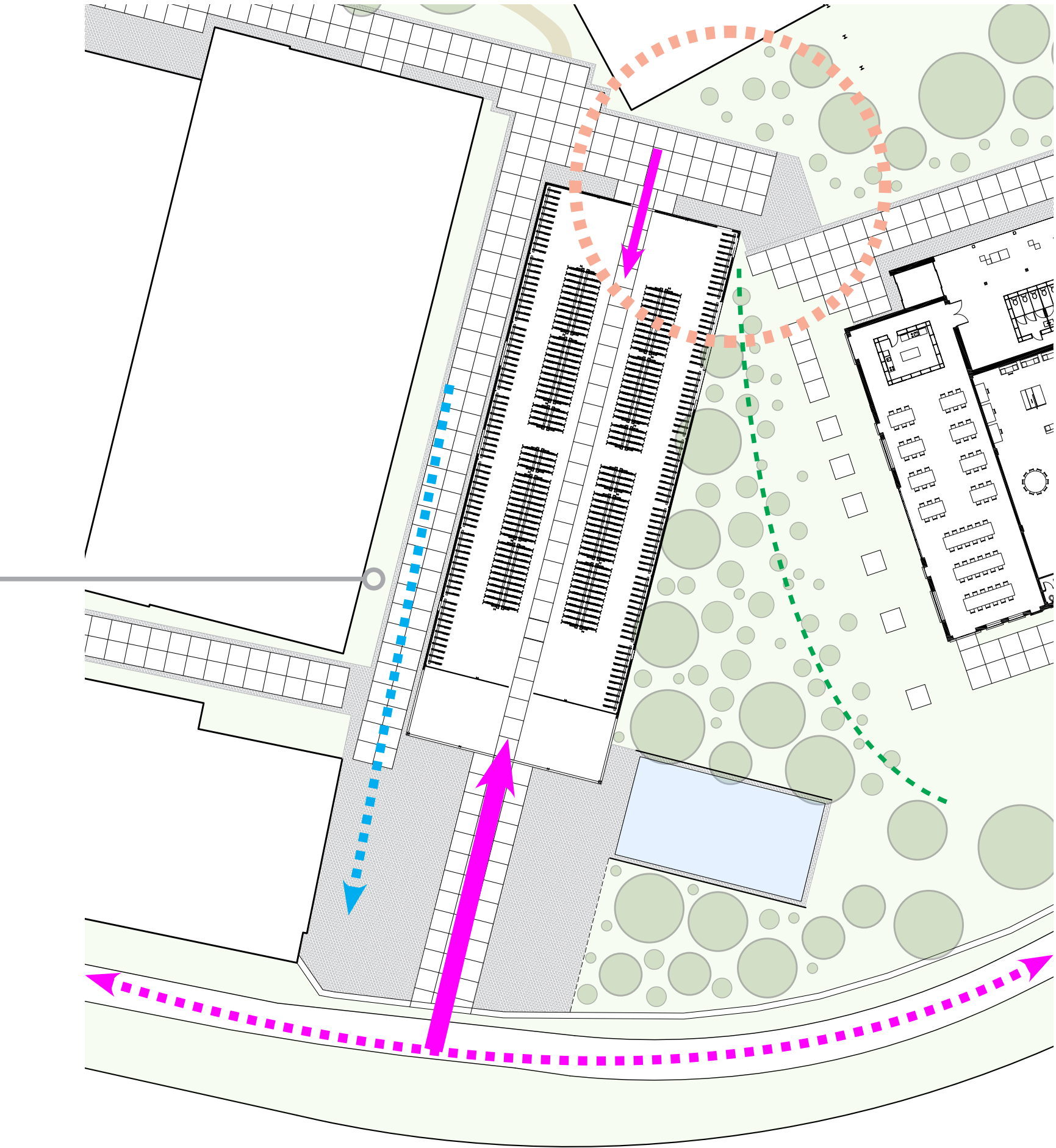

Bike Storage - main interventions

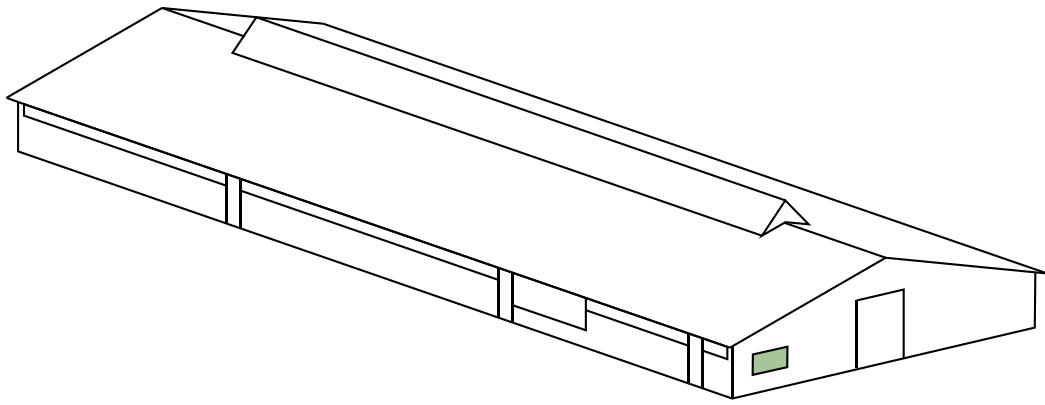
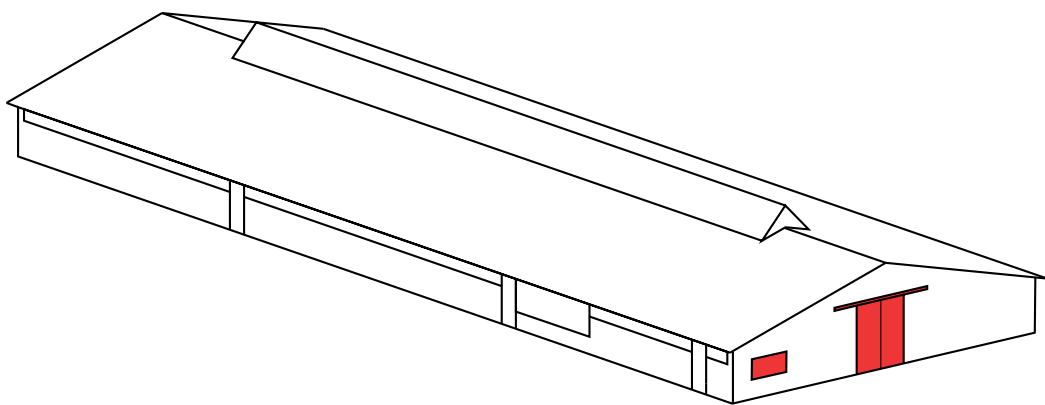

north

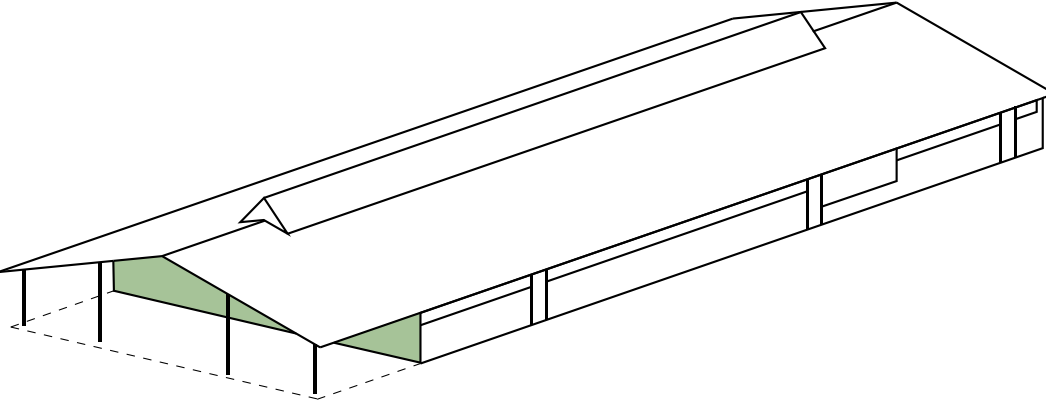
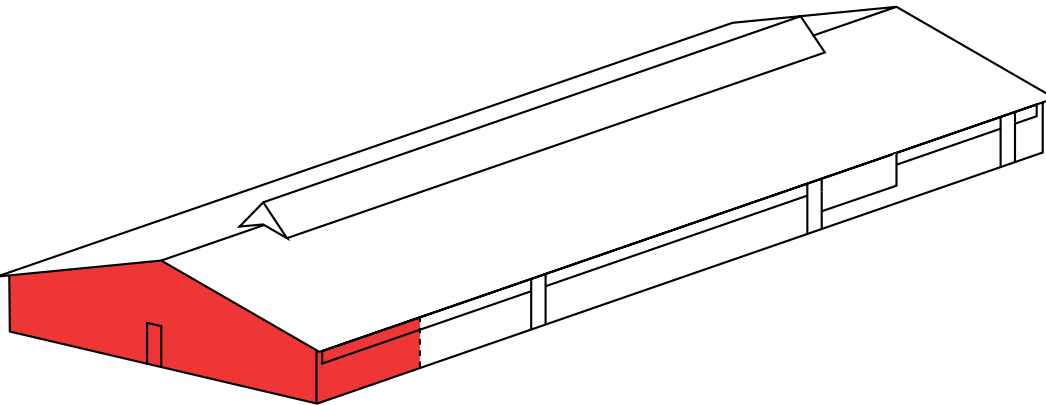

south

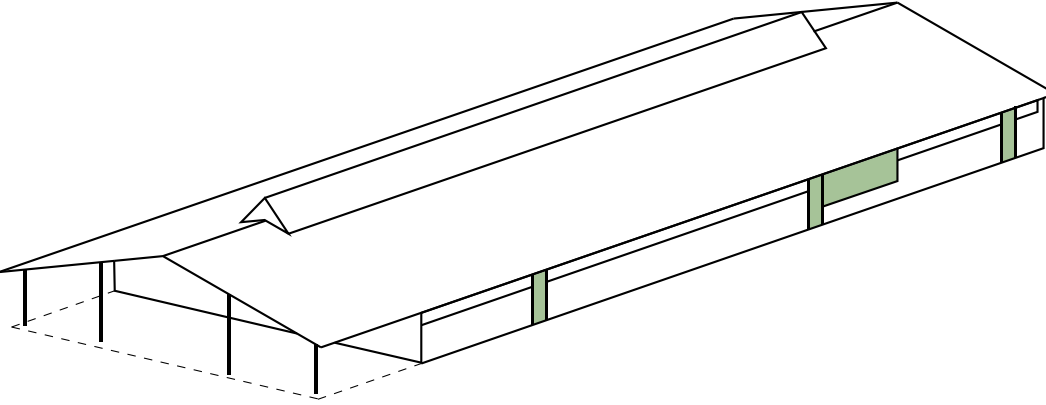
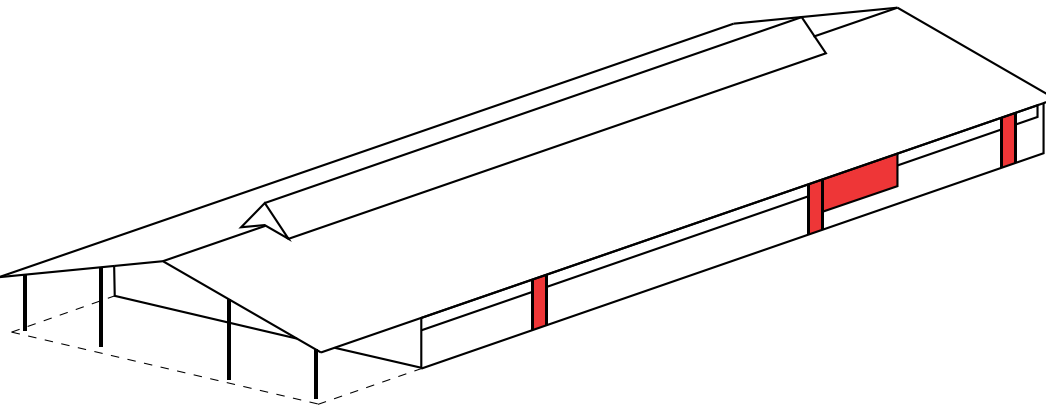

east & west

Bike Storage - impression south entrance



Bike Storage - impression north entrance



Bike Storage - plan

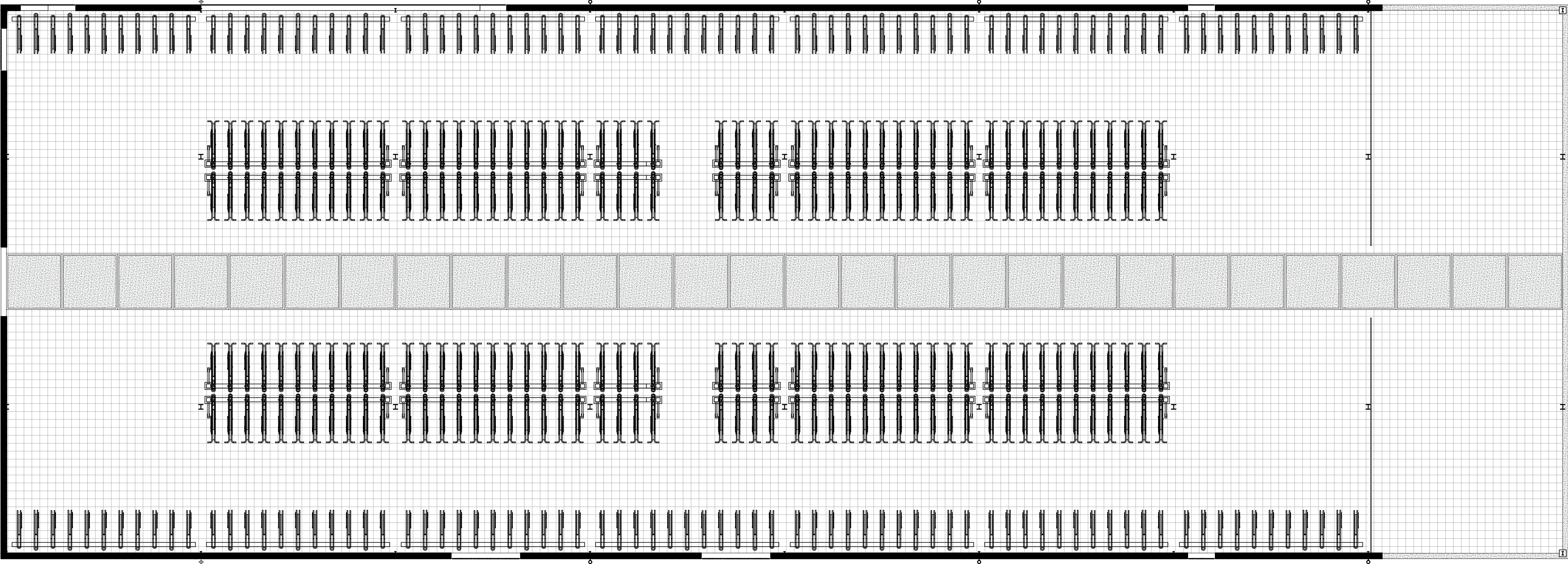

Bike Storage - plan

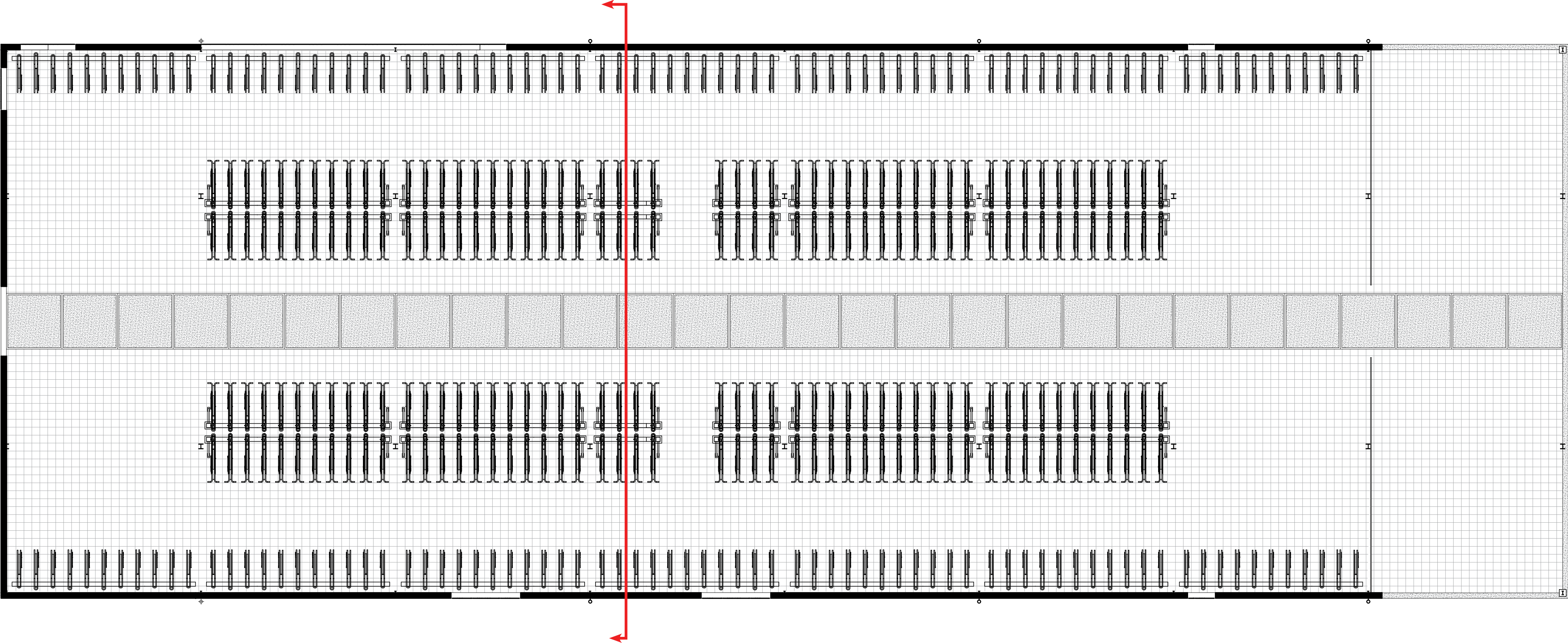

Bike Storage - section

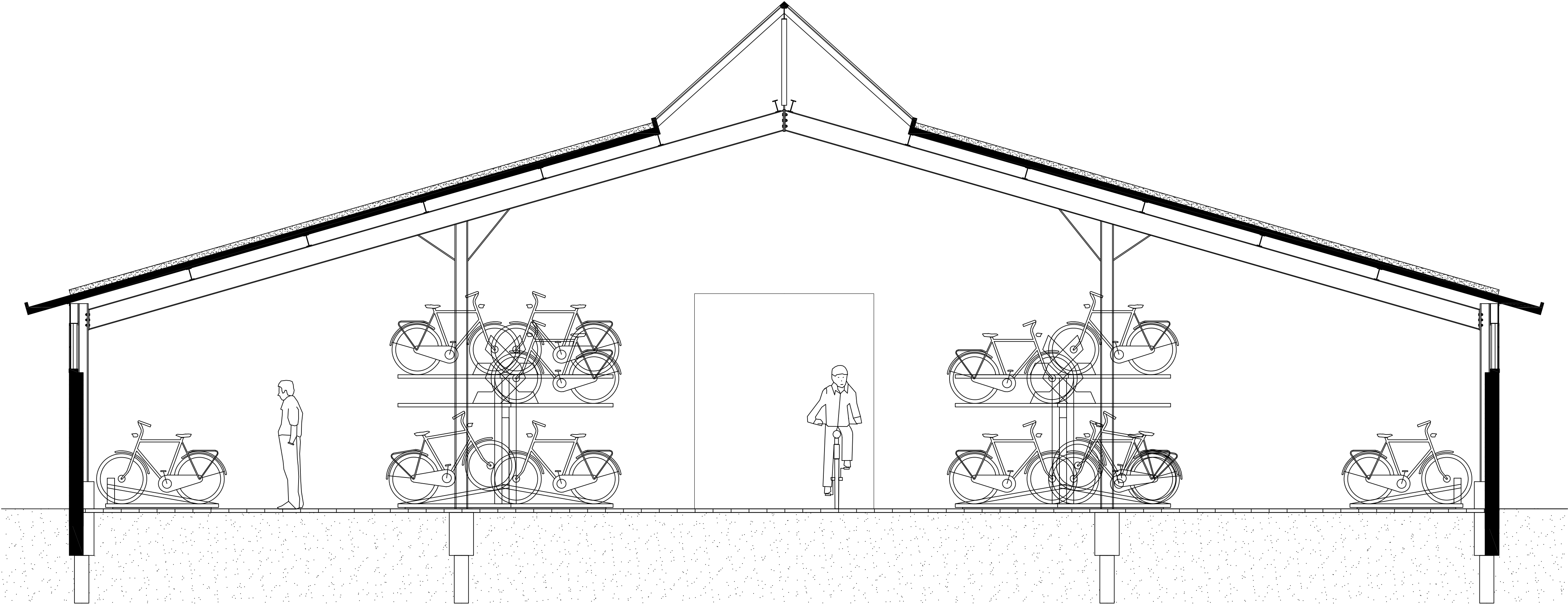

Bike Storage - impression interior



Bike Storage - impression interior



Ensemble - overview

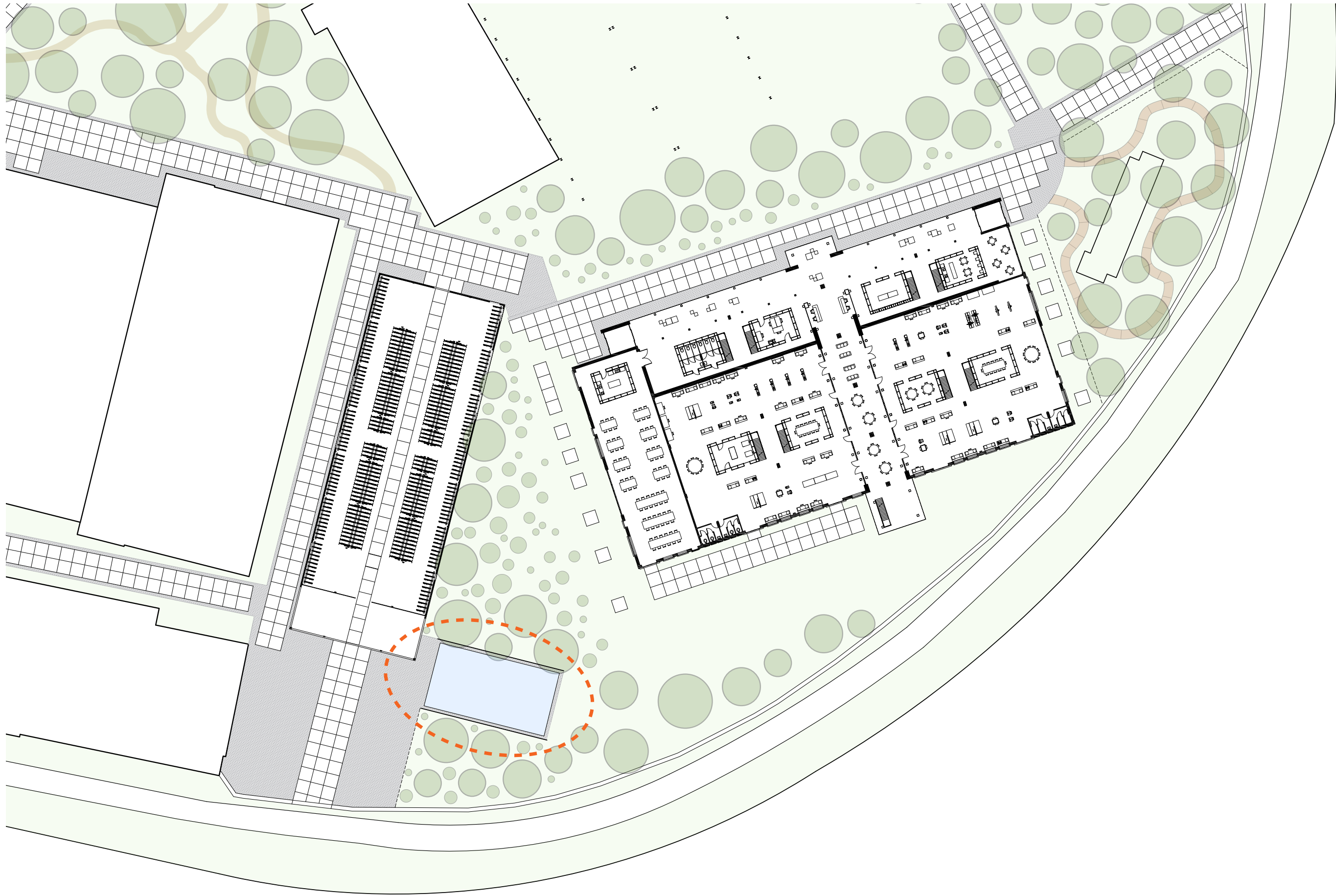

Romney Hut - starting points

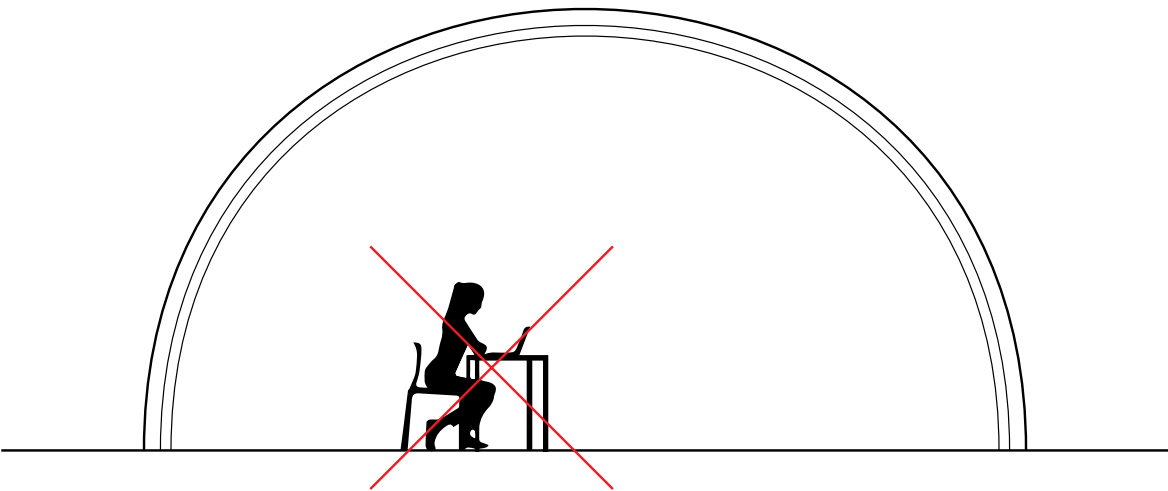

No permanent stay

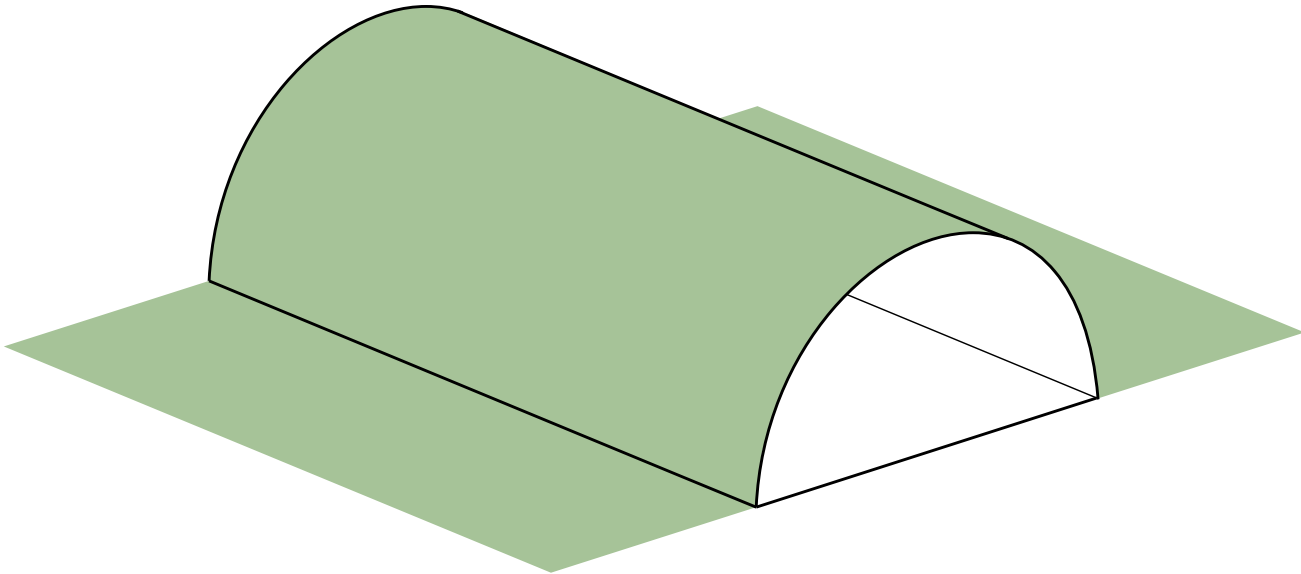

Keep curved facade

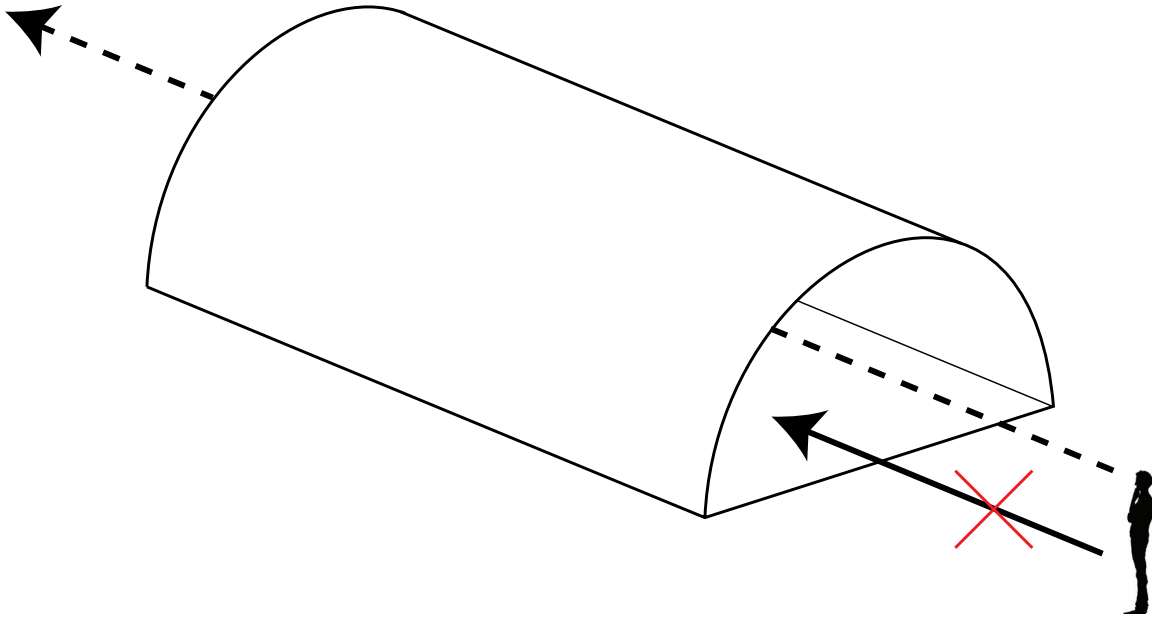

Create a visual tunnel

Romney Hut - main interventions & context

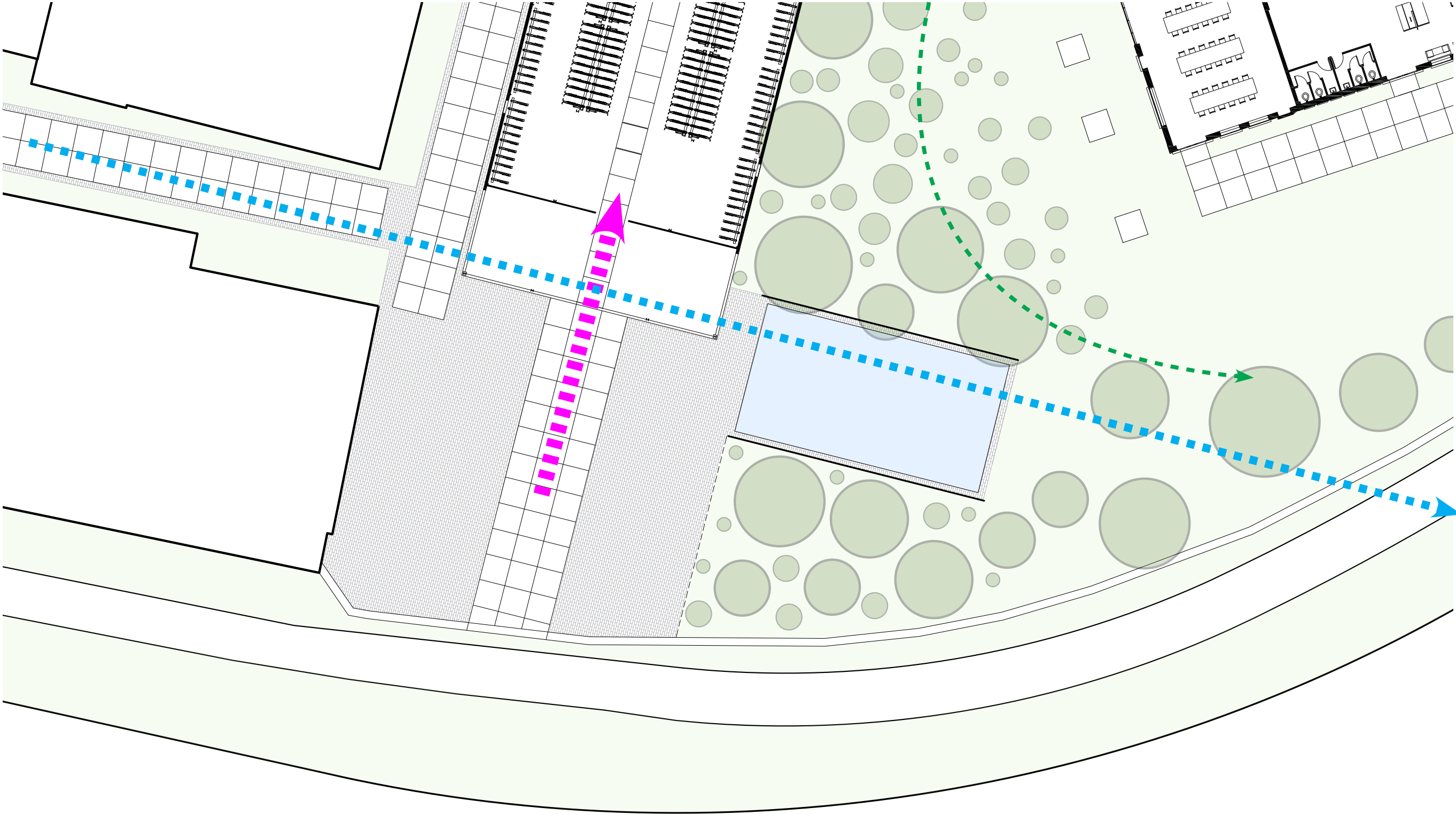
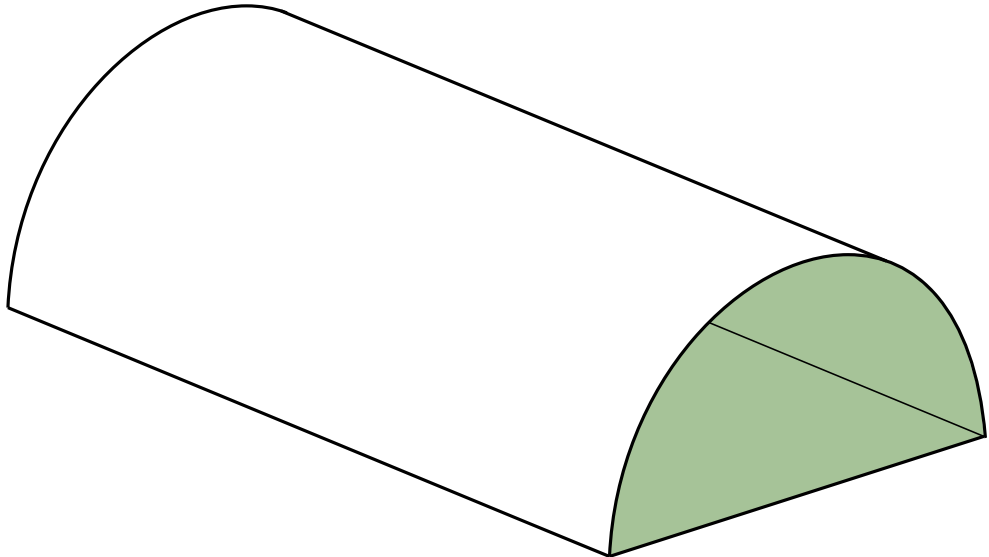
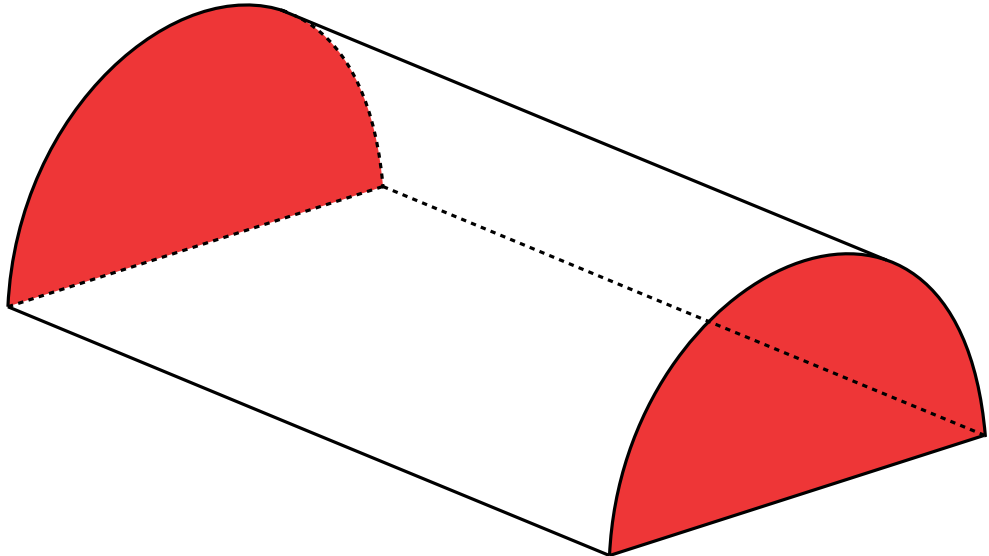

Romney Hut - impression

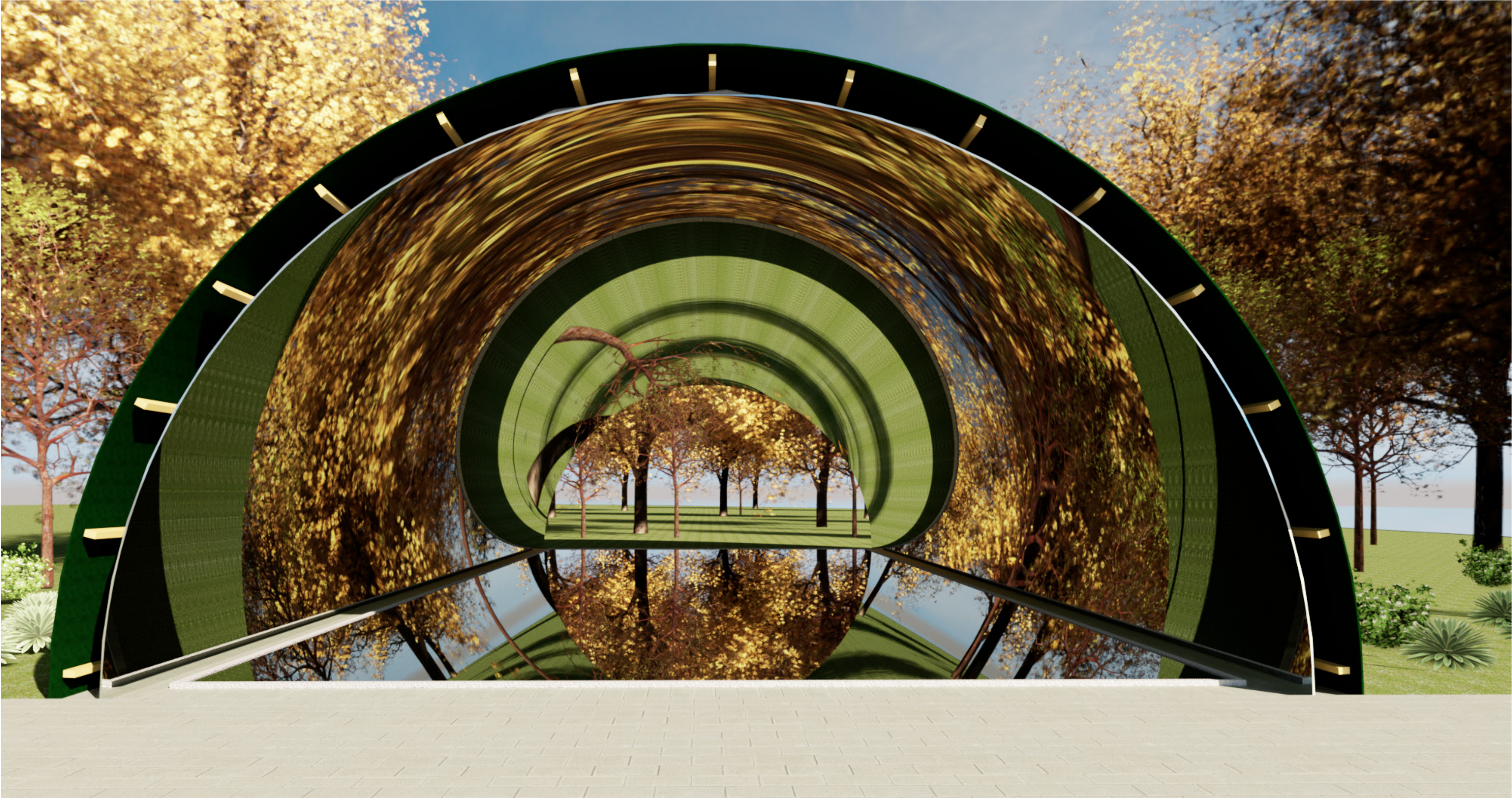

Ensemble - overview

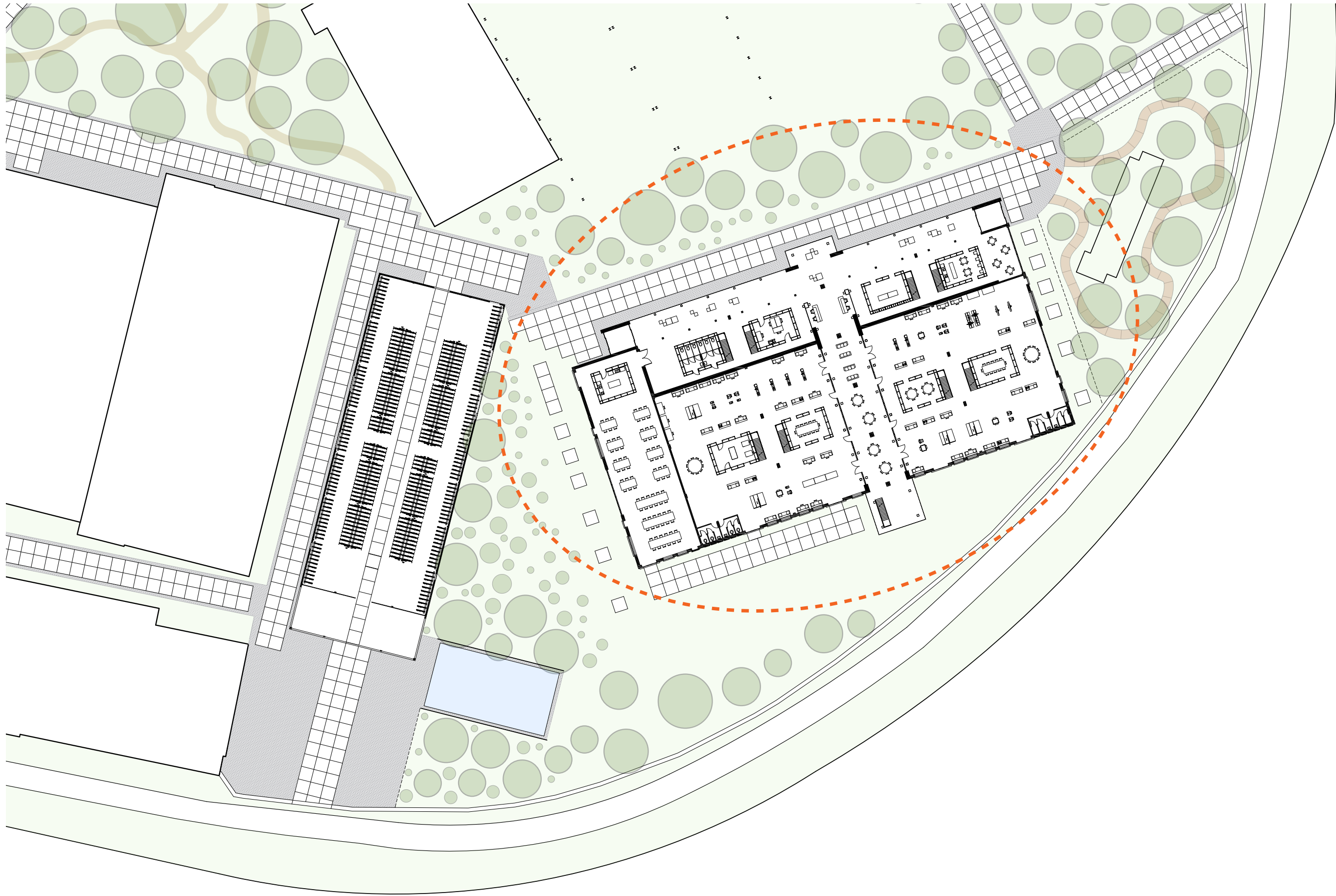

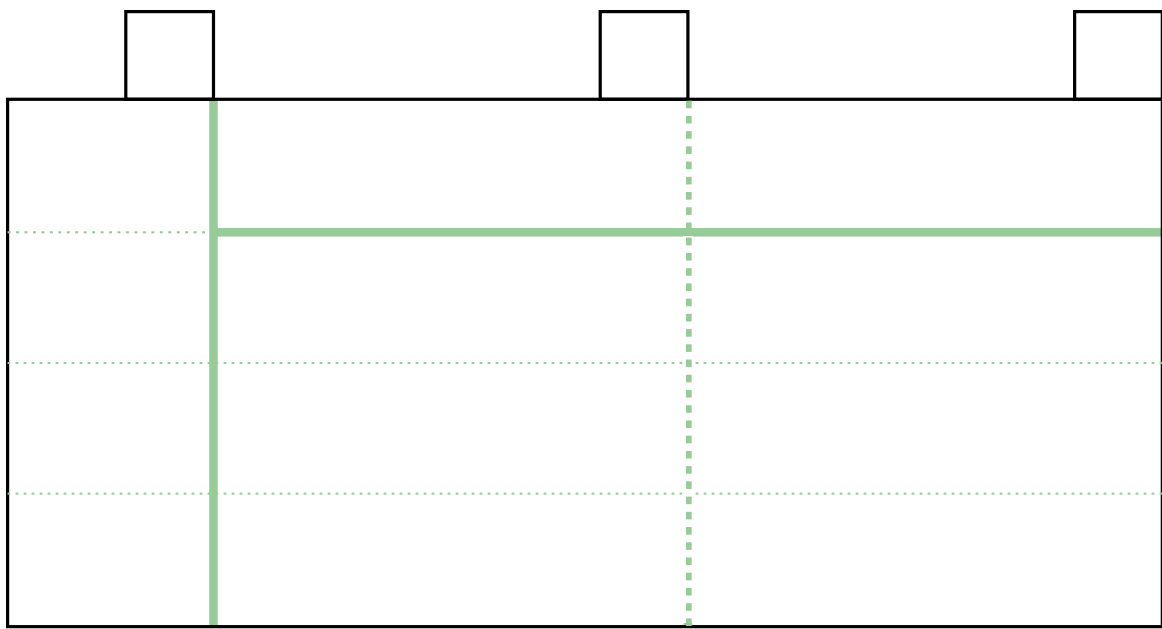

Use existing division

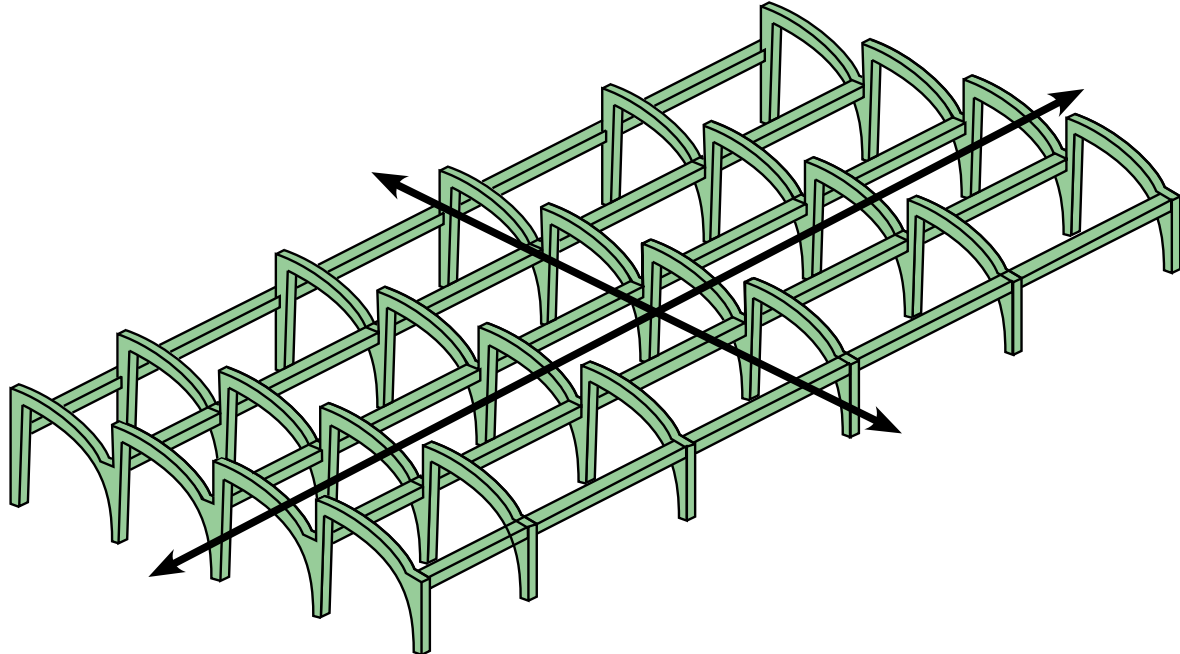

Keep visibility of continuous columns & beams

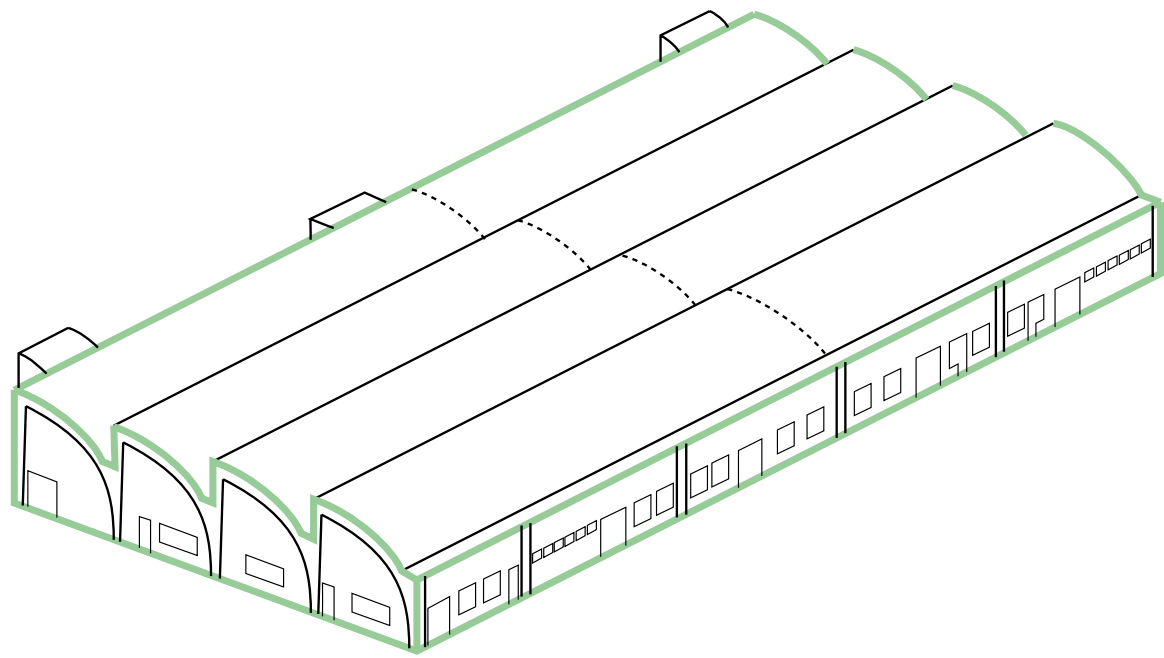

Visibility of contours

The Craftmanship Academy - main interventions

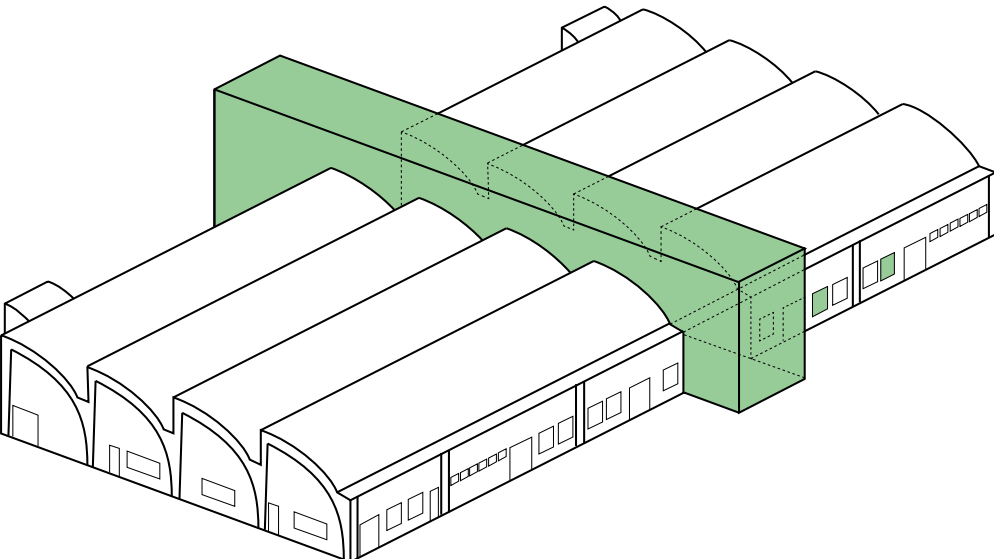
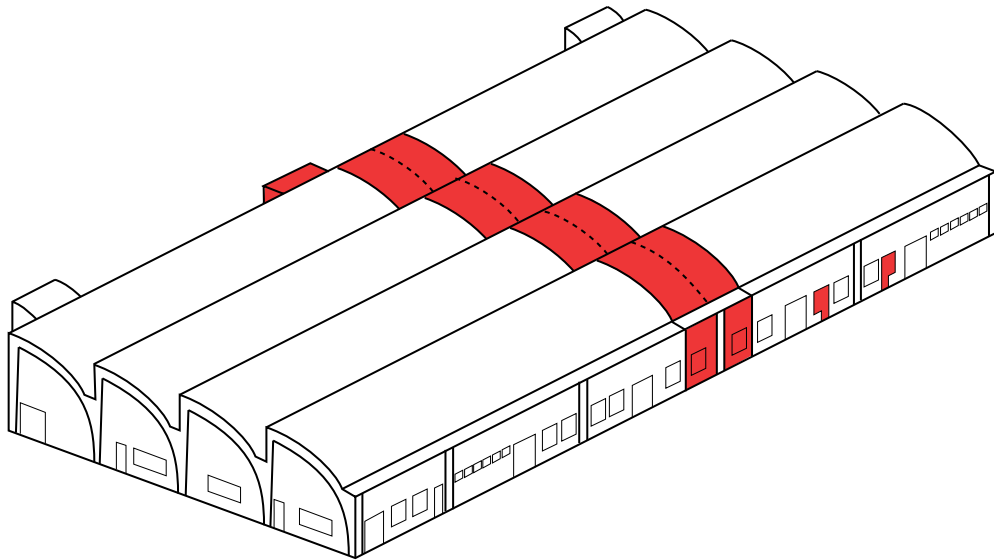

Marking the building

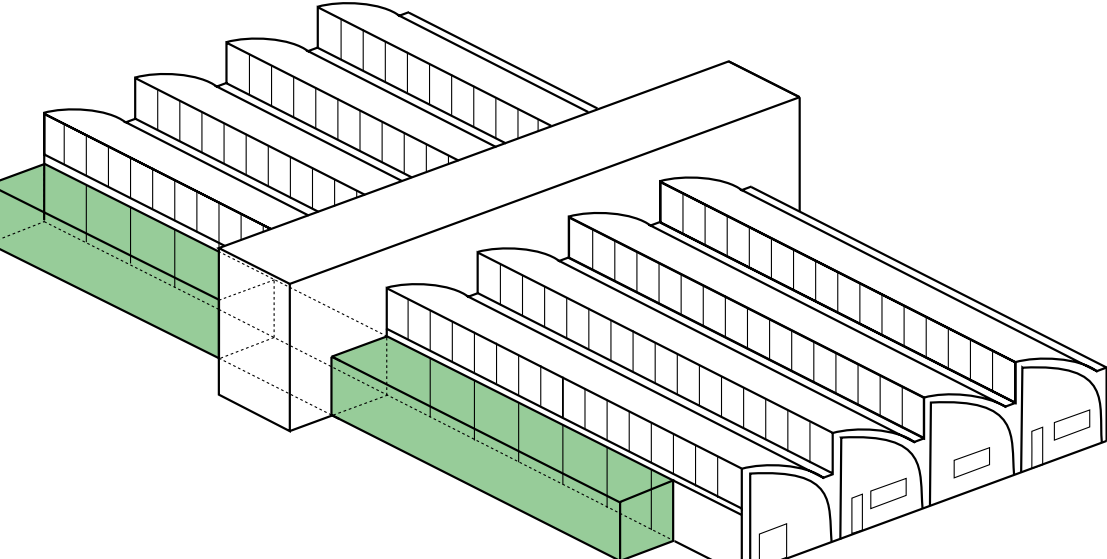
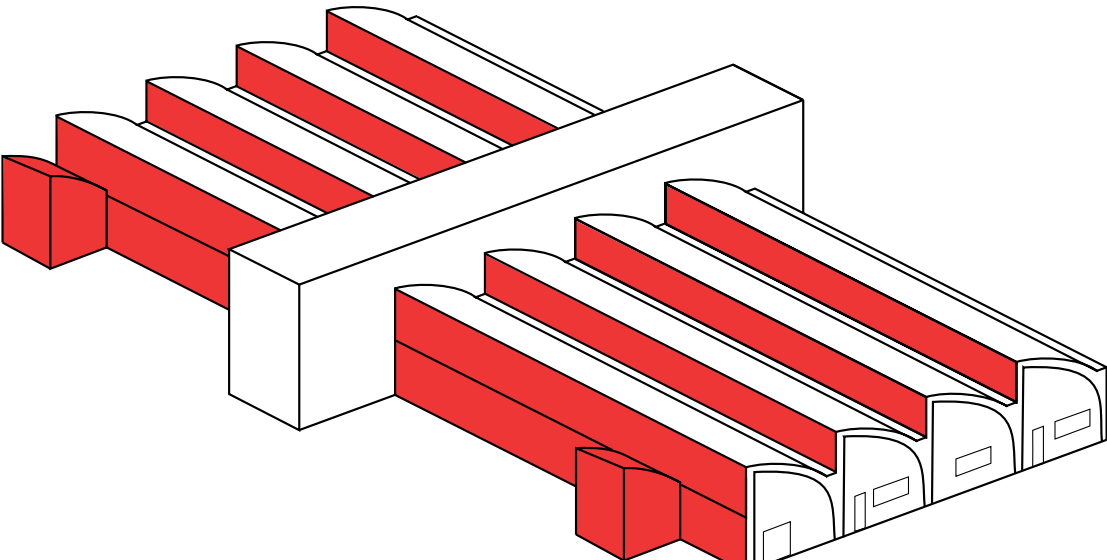

Adding a public/transition zone

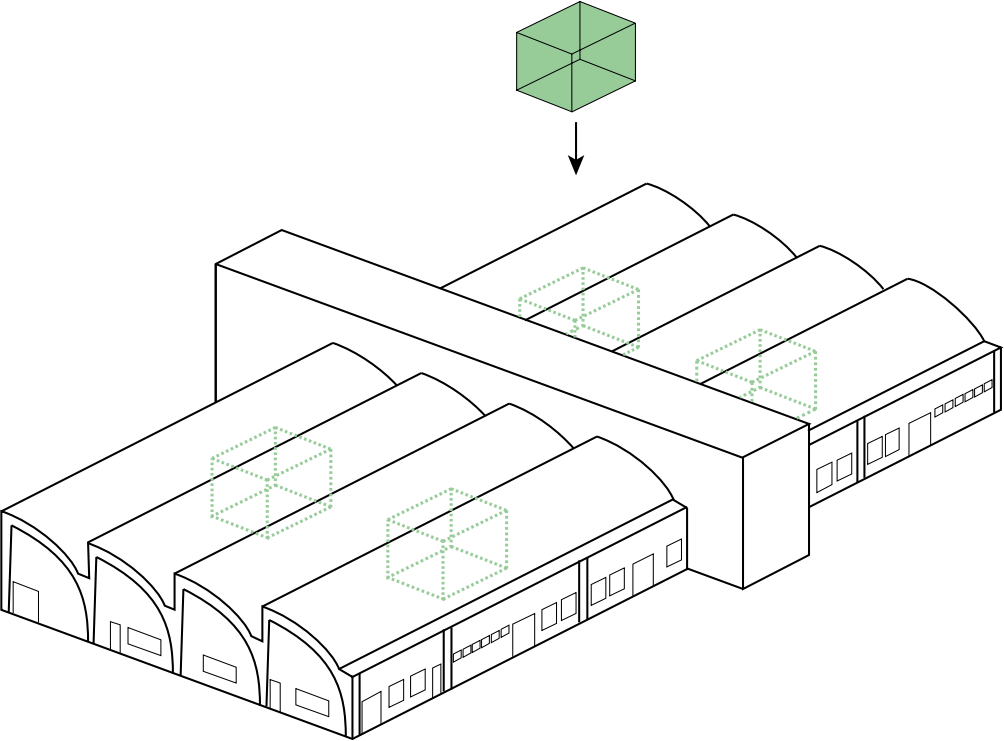

Adding interior frames

The Craftmanship Academy - main interventions

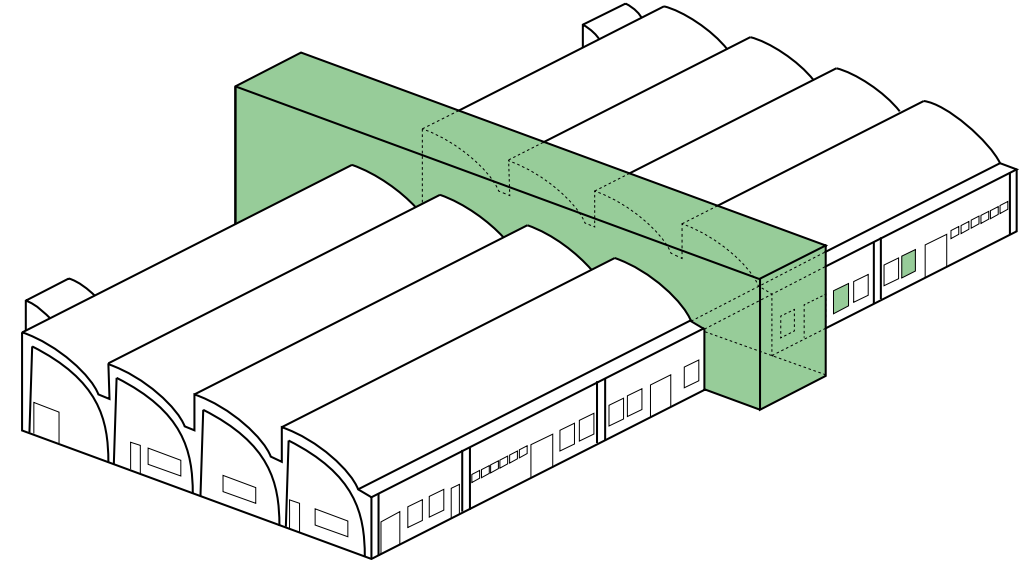
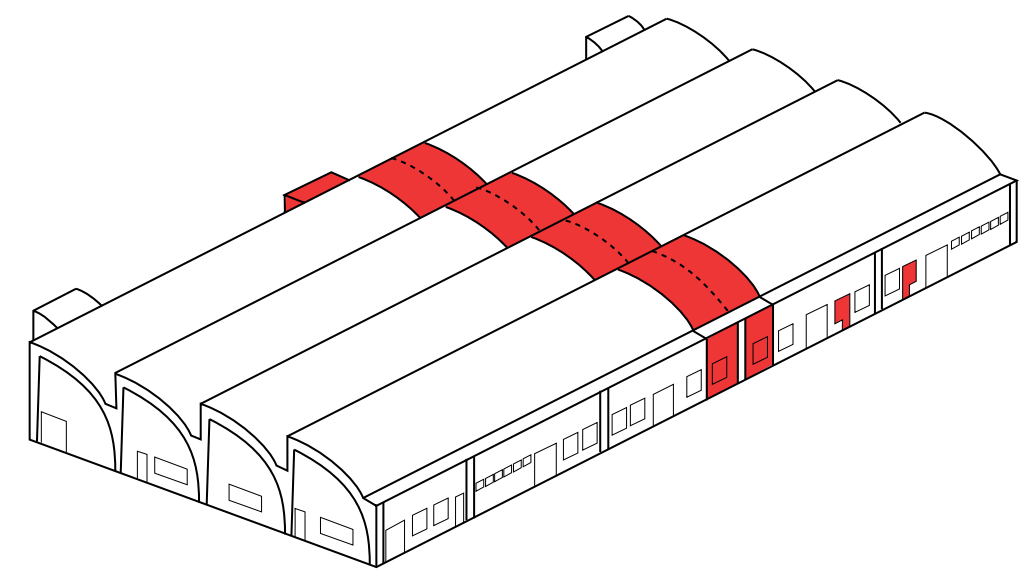

Marking the building

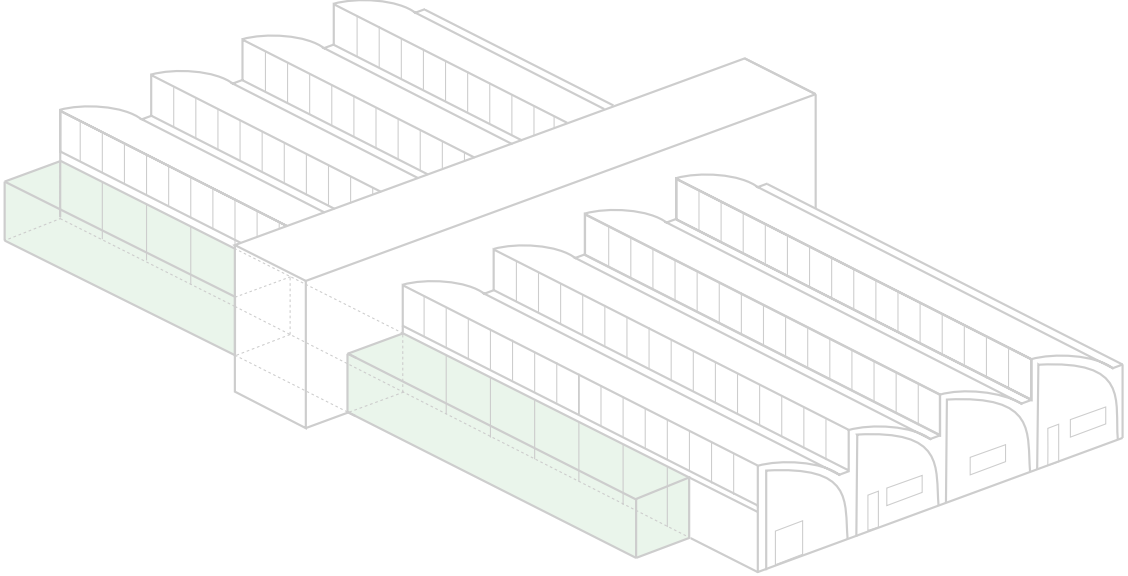
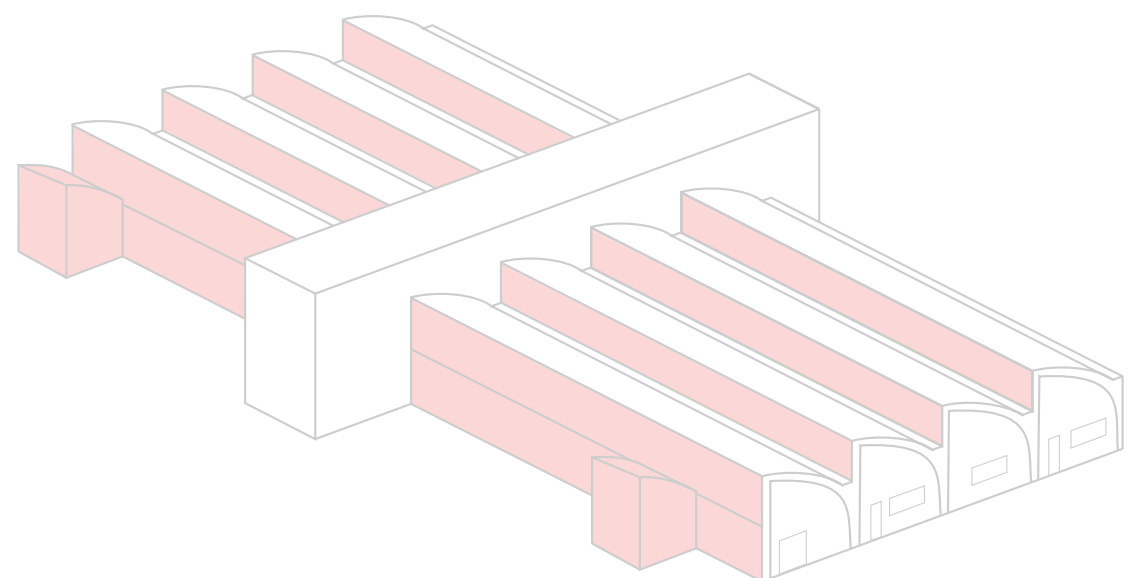

Adding a public/transition zone

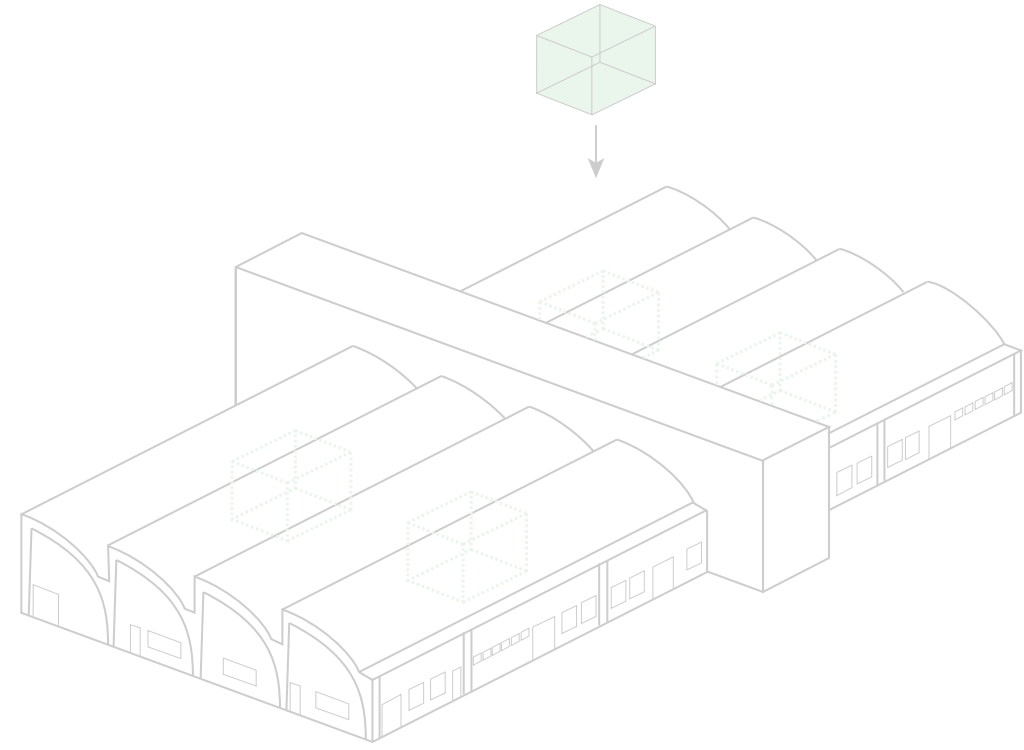

Adding interior frames

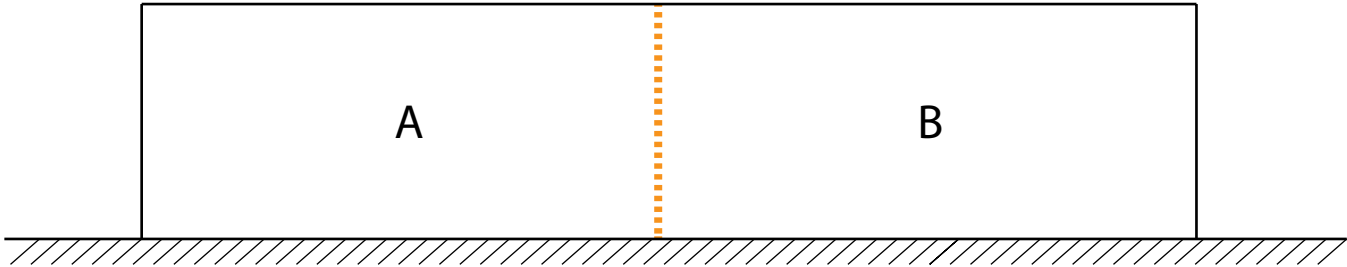

Splitting the building

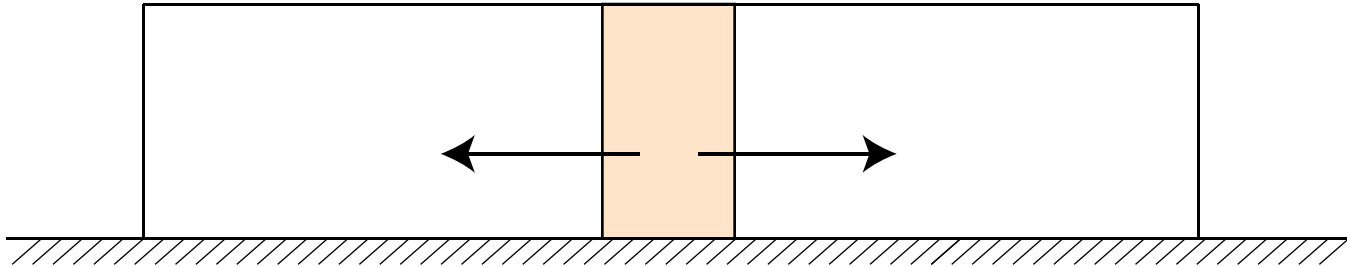

Creating routing

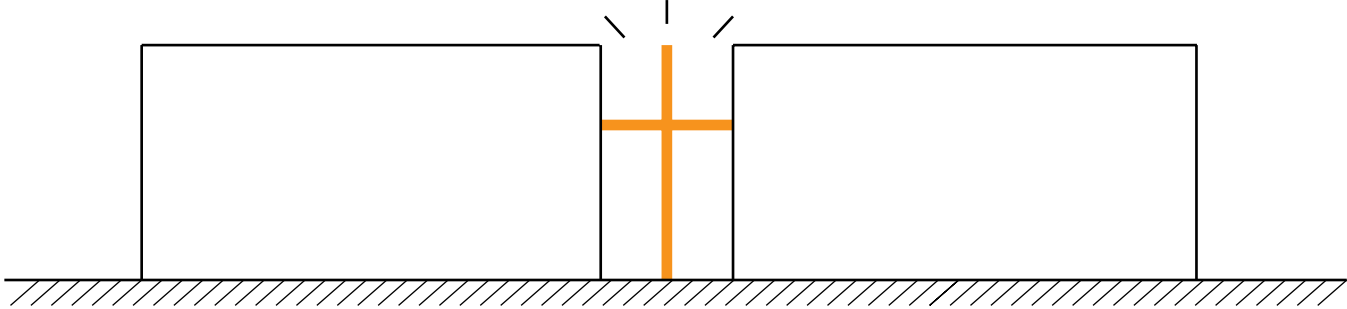

Expose structure

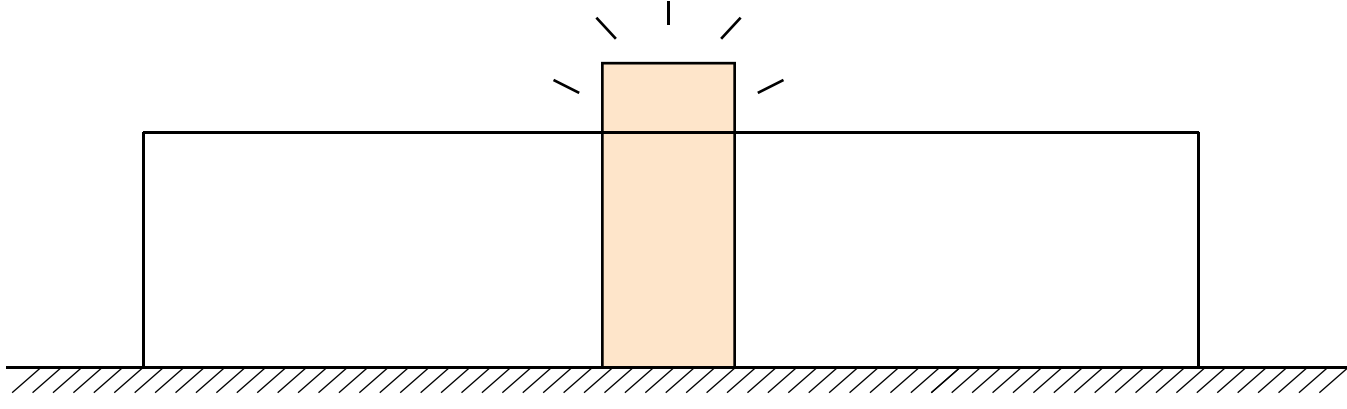

Mark the building

The Craftmanship Academy - main interventions

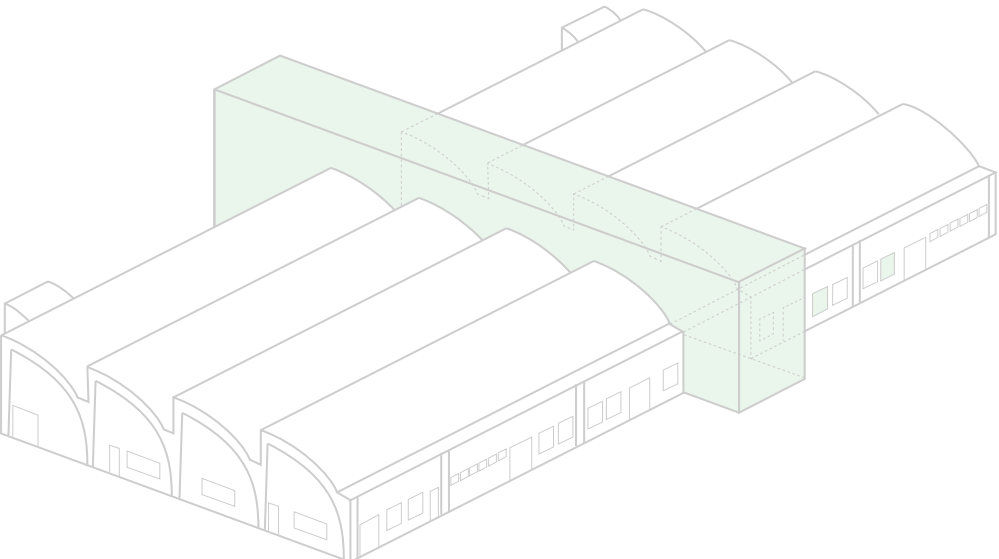
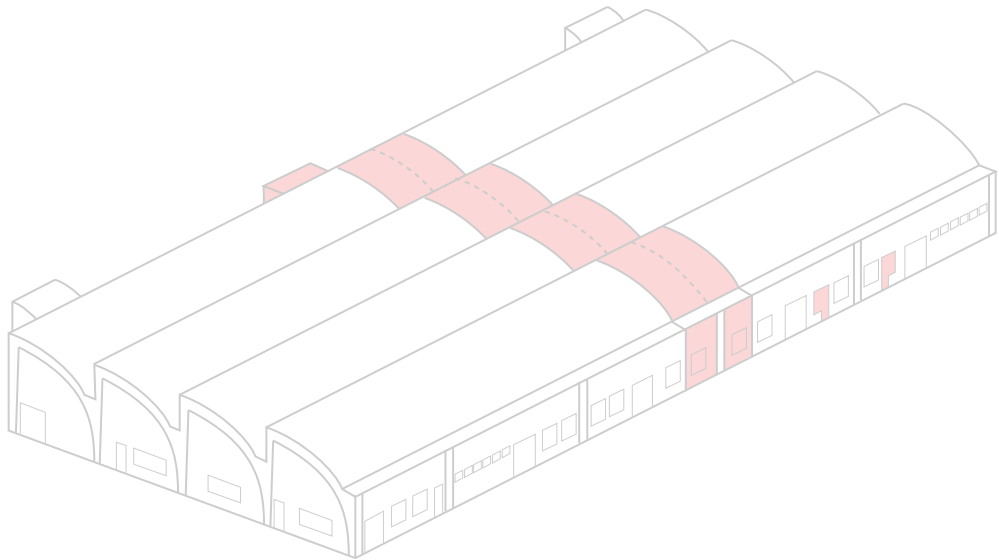

Marking the building

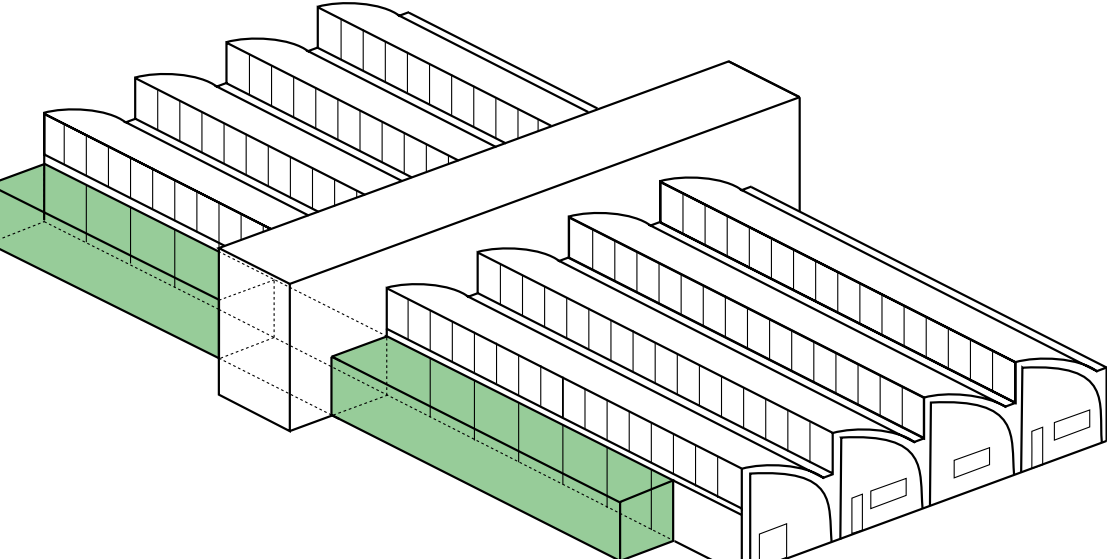
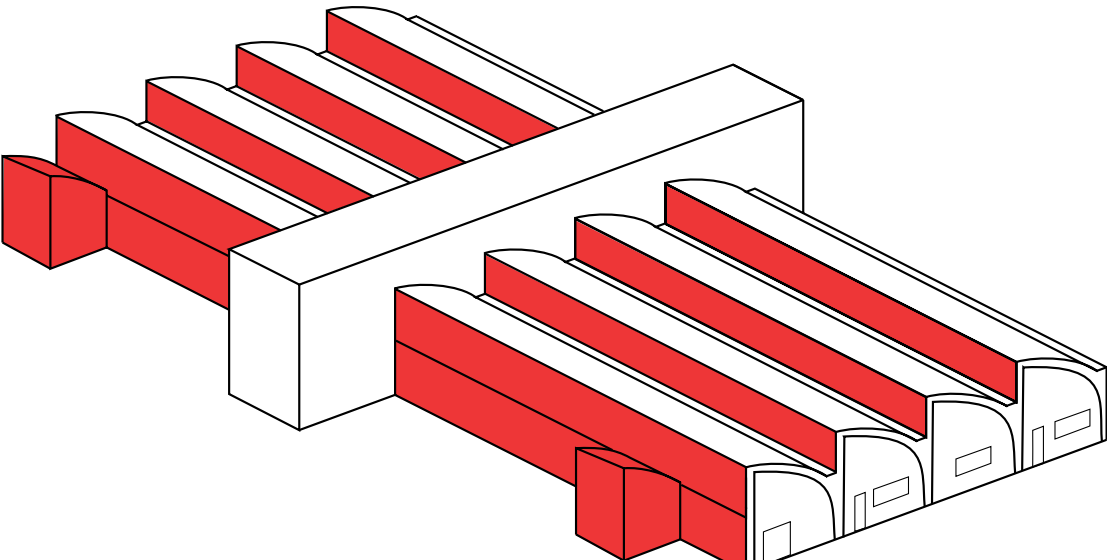

Adding a public/transition zone

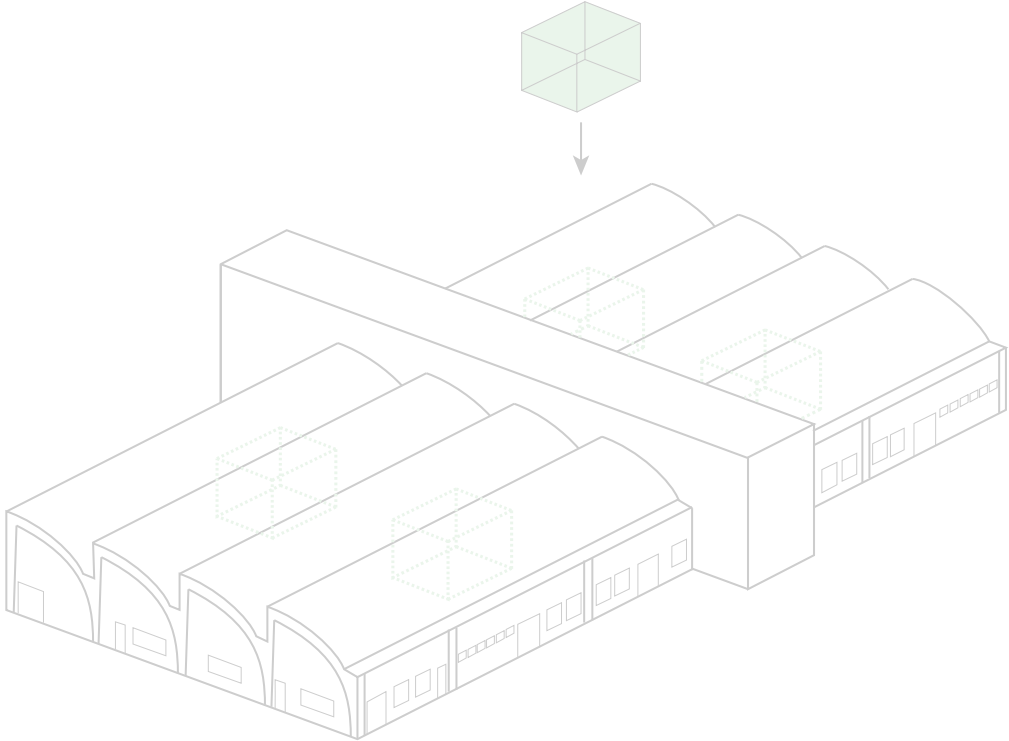

Adding interior frames

The Craftmanship Academy - main interventions

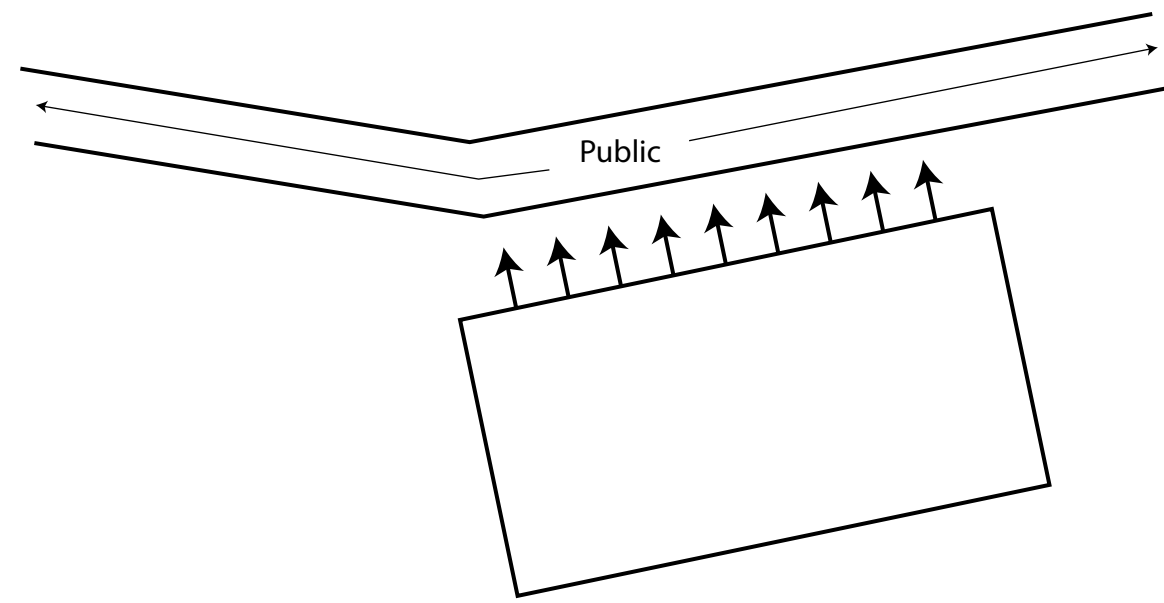

Connection to public

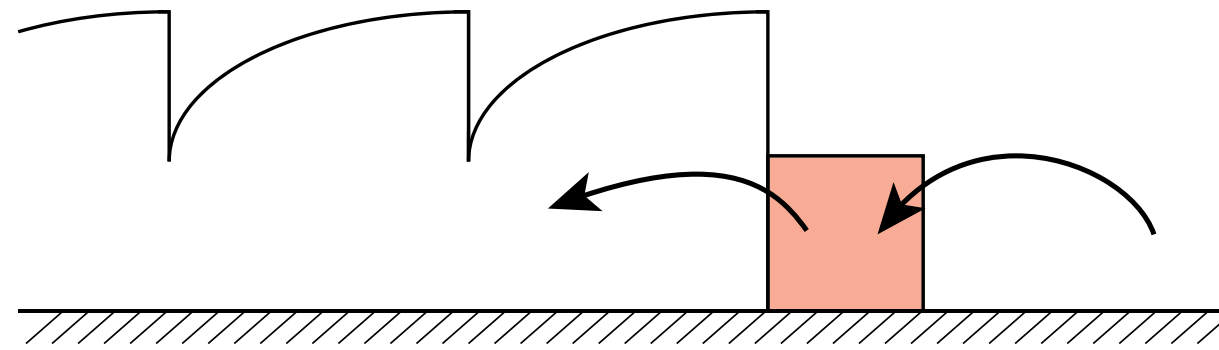

Entrance/transition zone

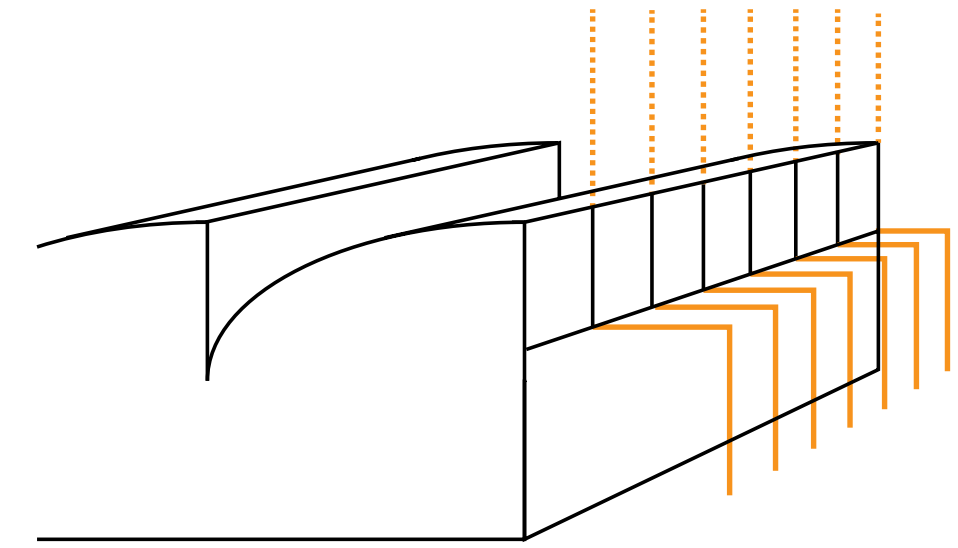

Express articulation of facade

The Craftmanship Academy - main interventions

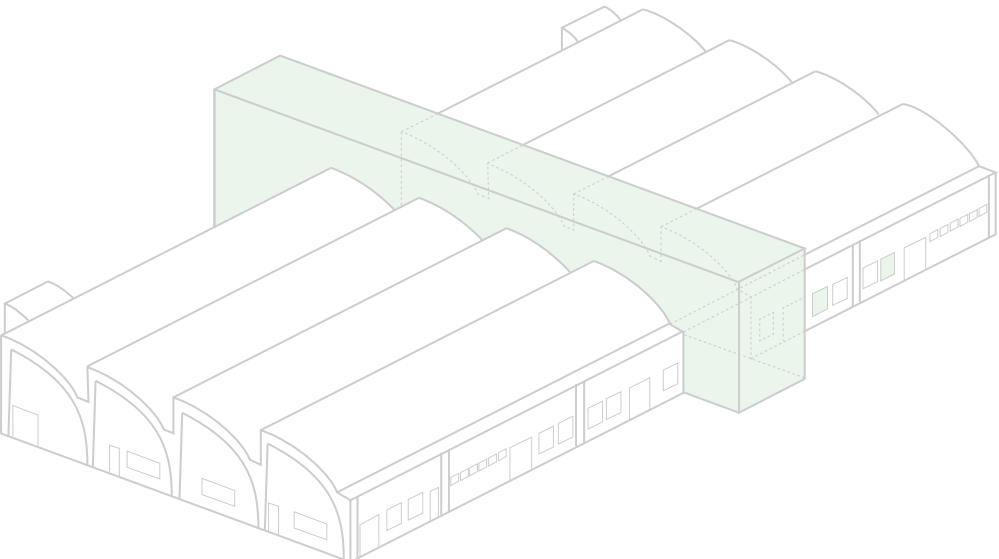
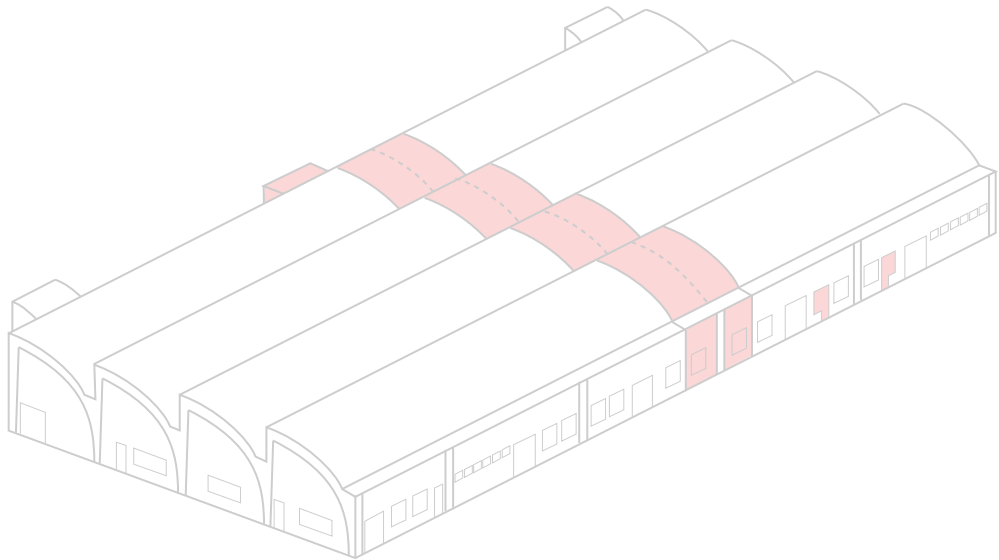

Marking the building

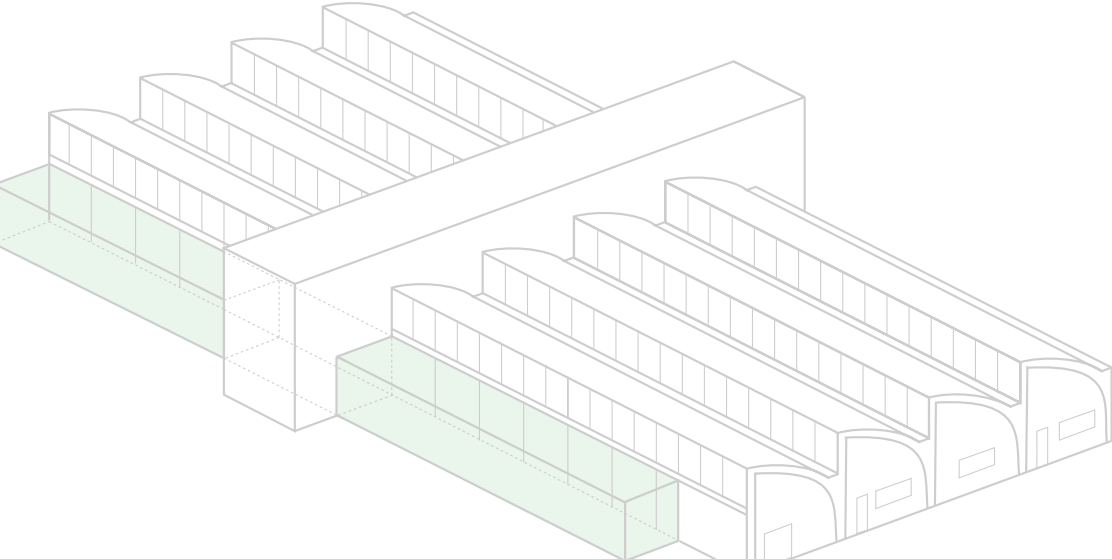
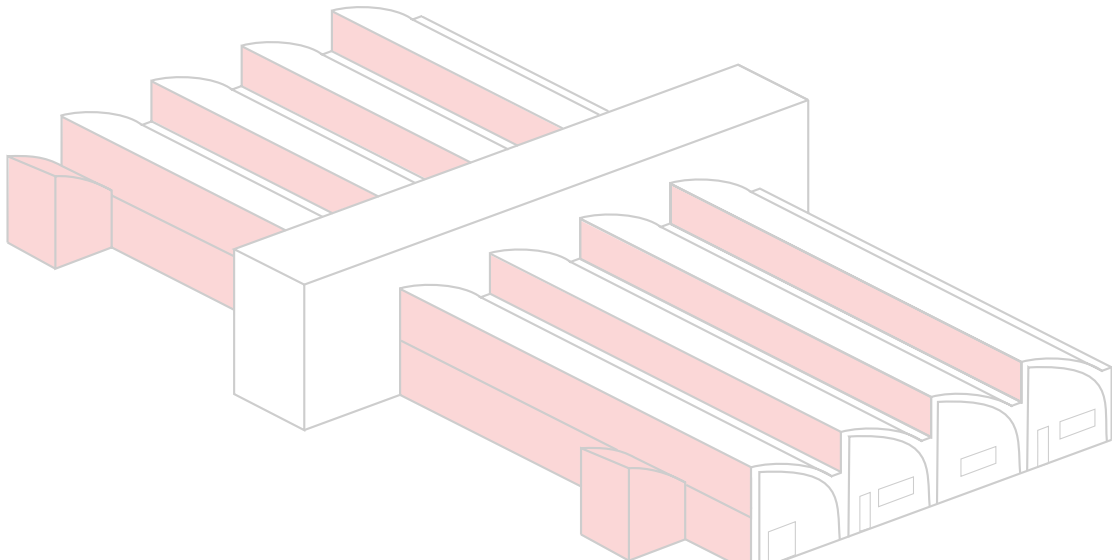

Adding a public/transition zone

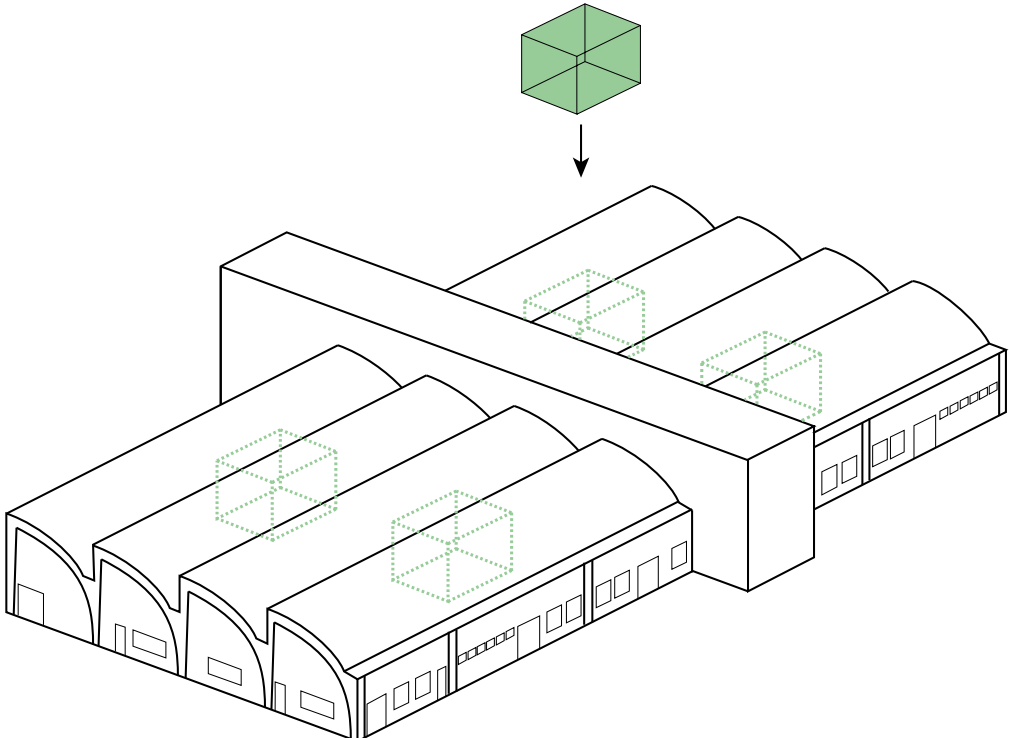

Adding interior frames

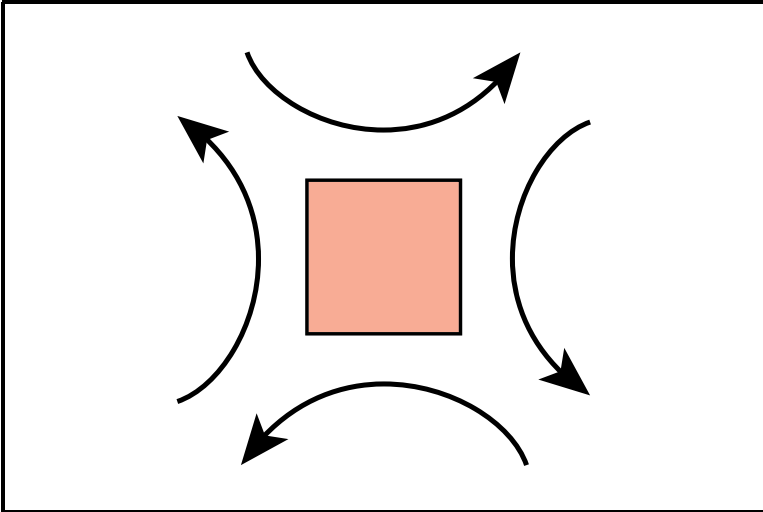

Deviding space

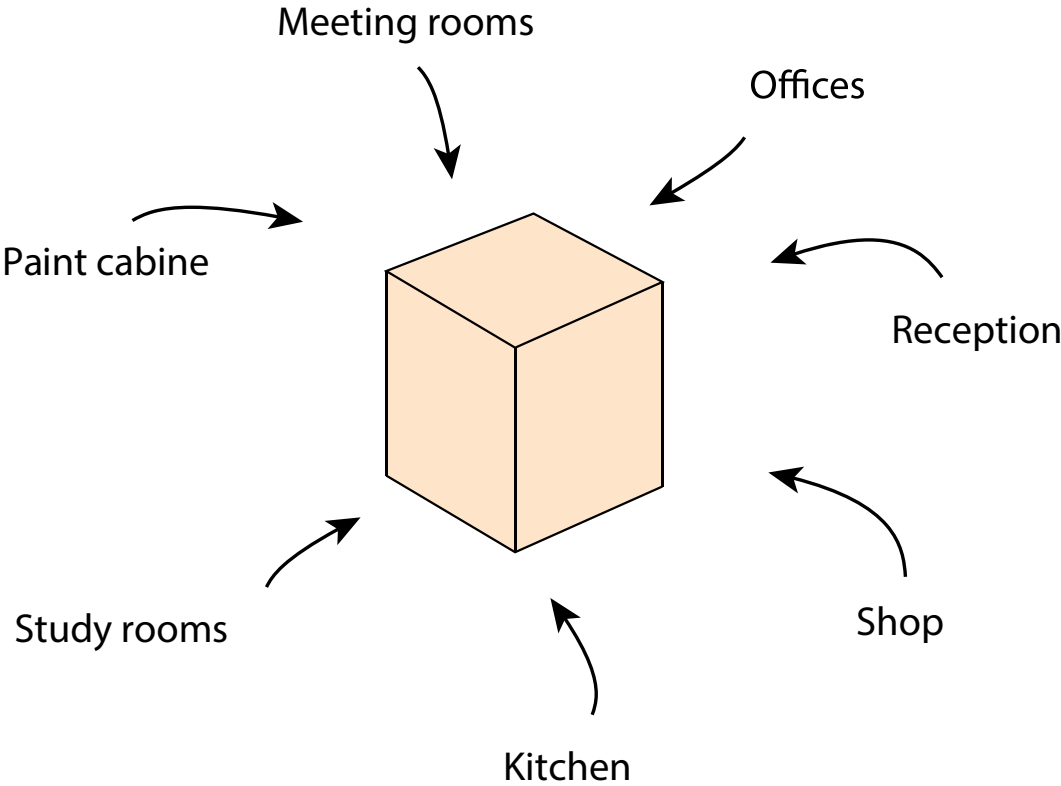

Multifunctional/adaptable

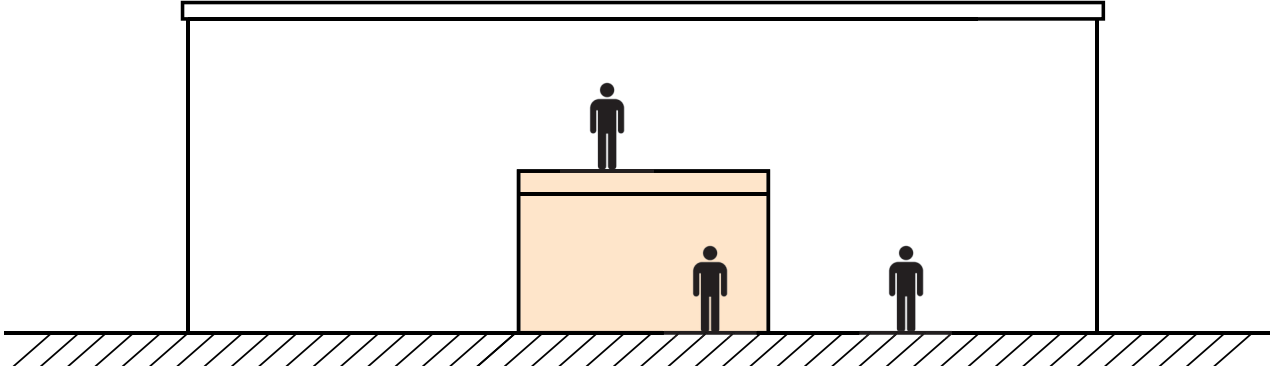

Better usage of volume

The Craftmanship Academy - main interventions

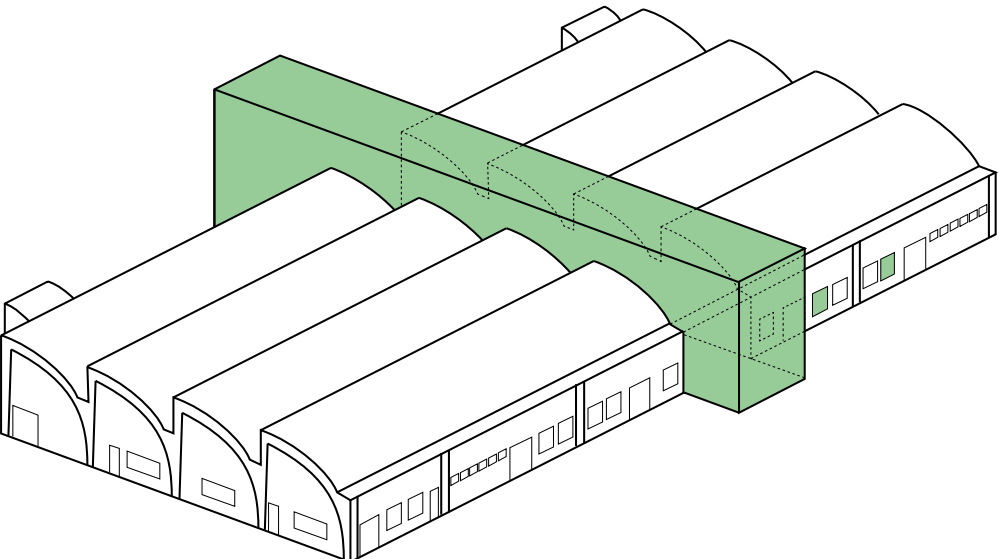
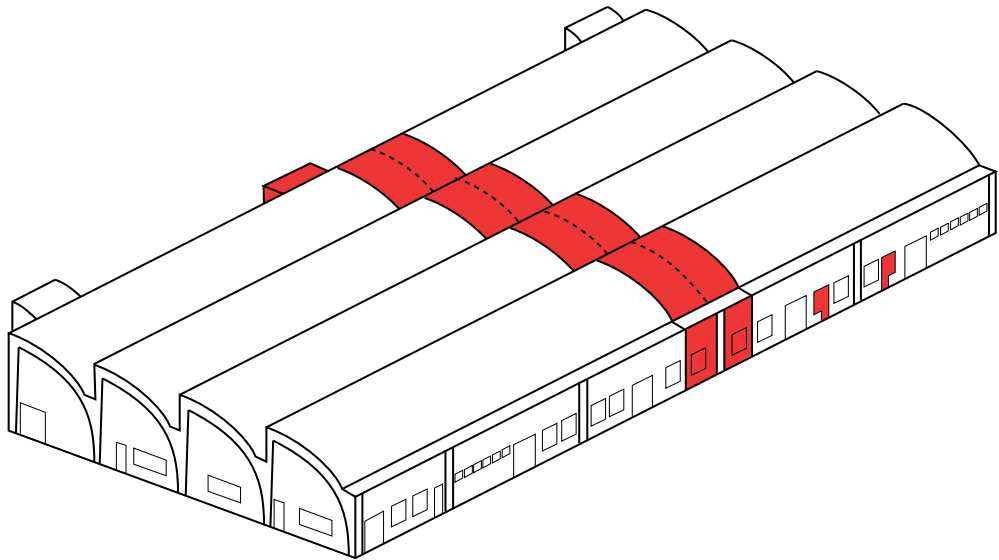

Marking the building

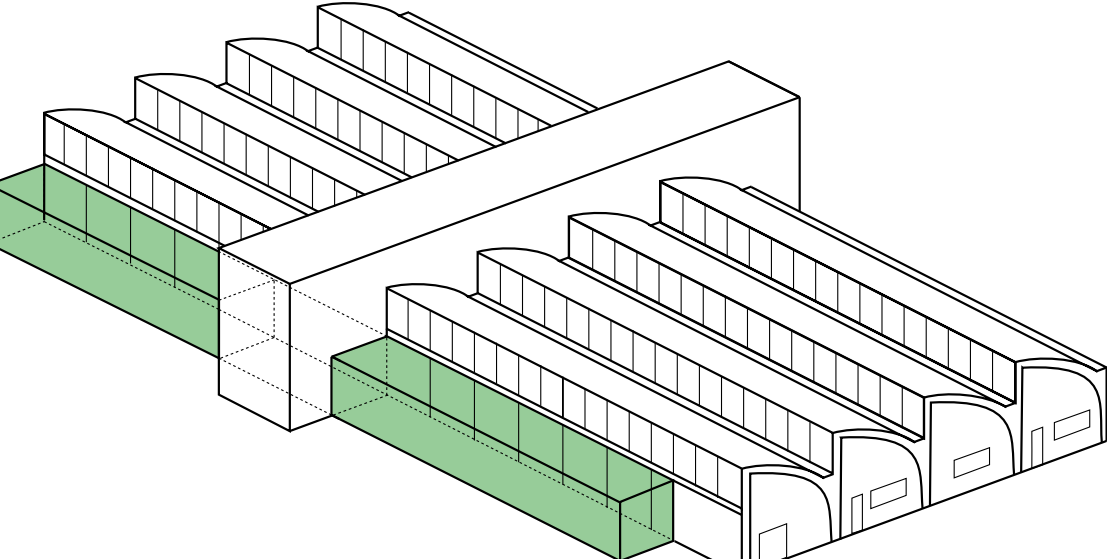
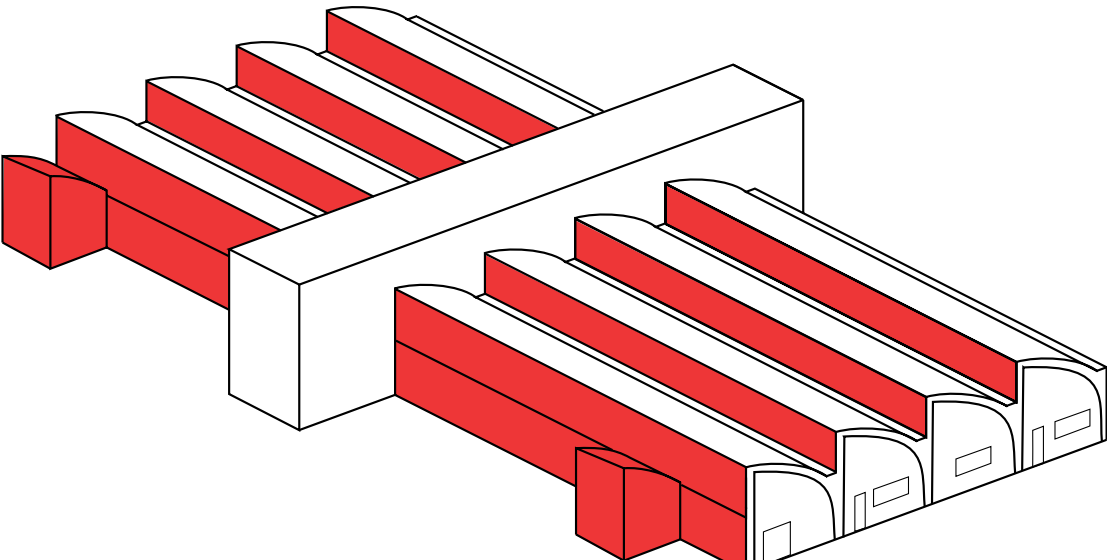

Adding a public/transition zone

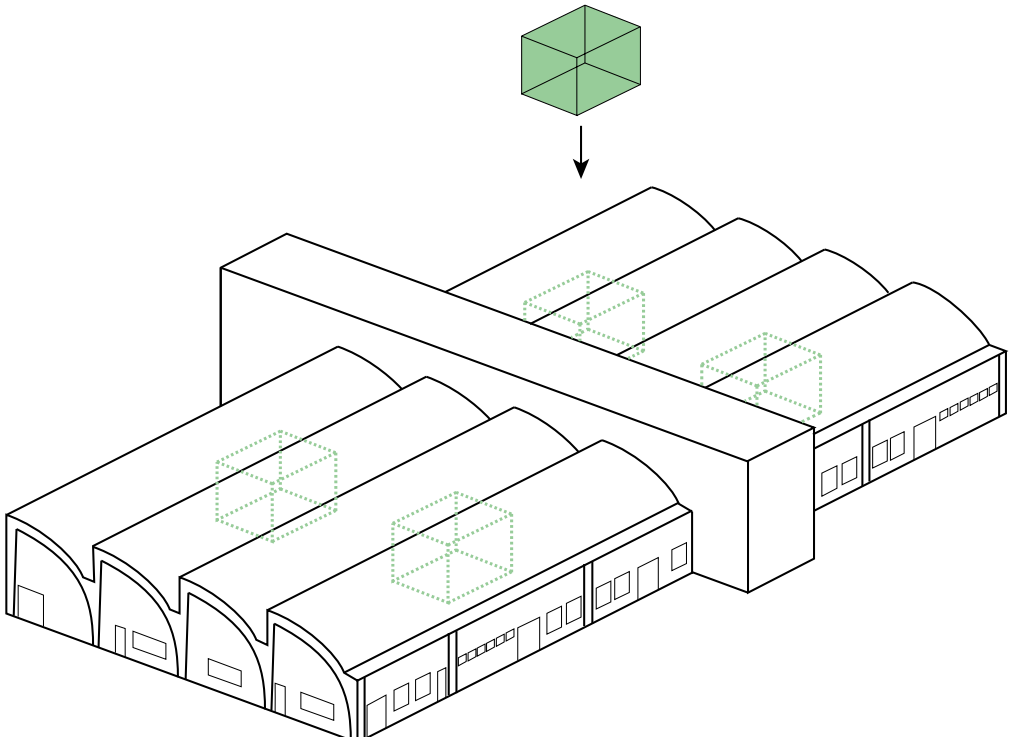

Adding interior frames

The Craftmanship Academy - ground floor



The Craftmanship Academy - ground floor



The Craftmanship Academy - ground floor



The Craftmanship Academy - ground floor



The Craftmanship Academy - section

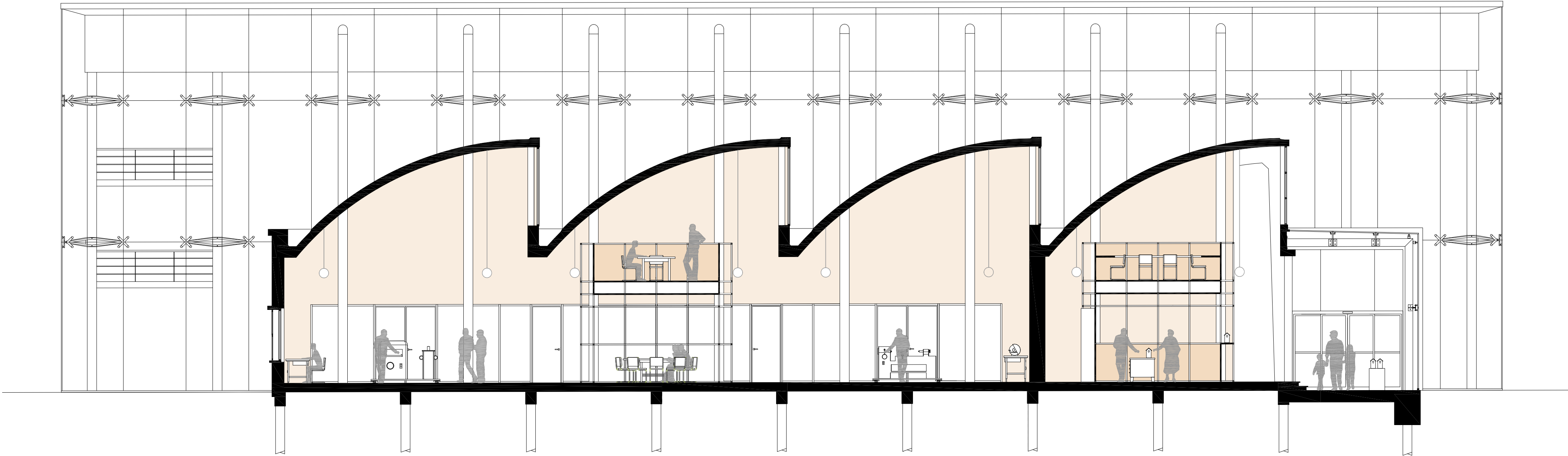

The Craftmanship Academy - ground floor



The Craftmanship Academy - context

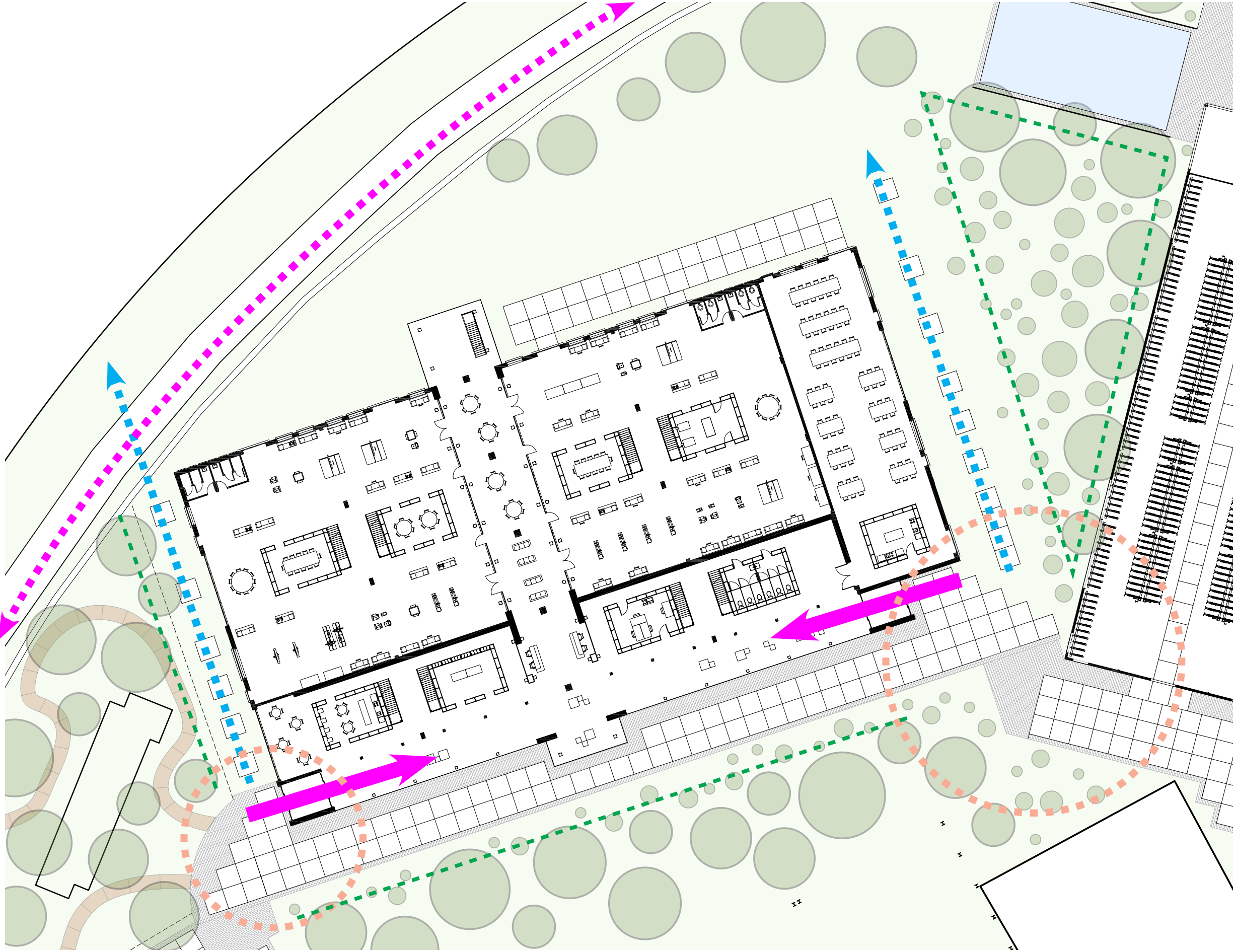

The Craftmanship Academy - impression public hall



The Craftmanship Academy - ground floor



The Craftmanship Academy - ground floor

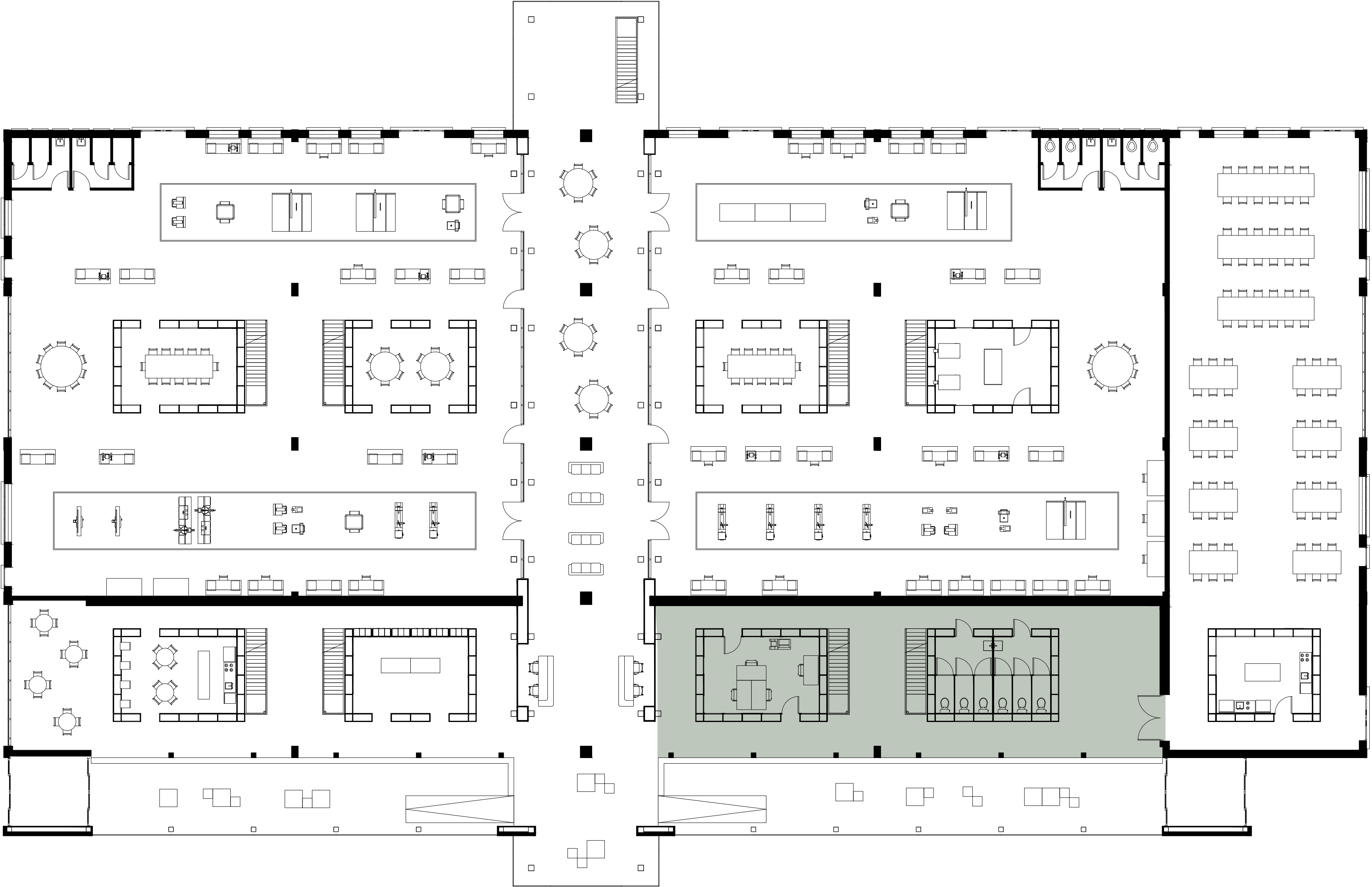

The Craftmanship Academy - ground floor



The Craftmanship Academy - ground floor

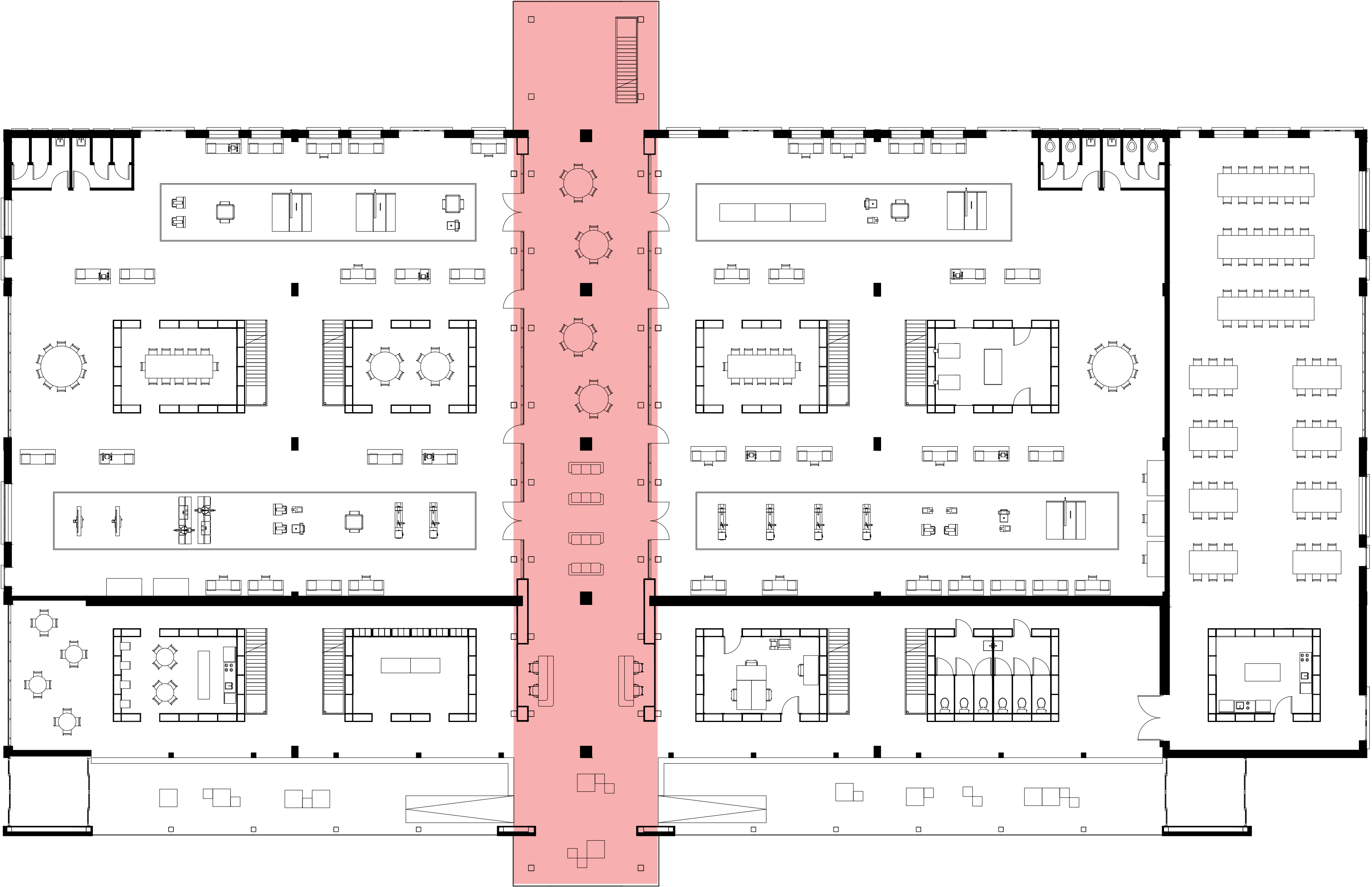

The Craftmanship Academy - section

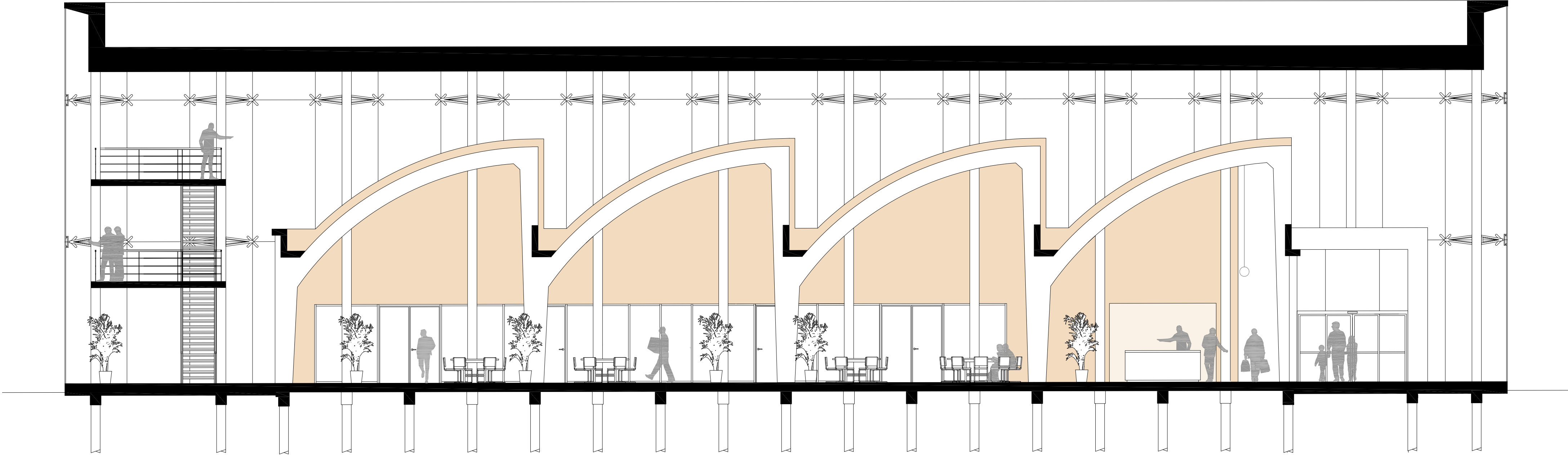

The Craftmanship Academy - impression central hall



The Craftmanship Academy - impression central hall

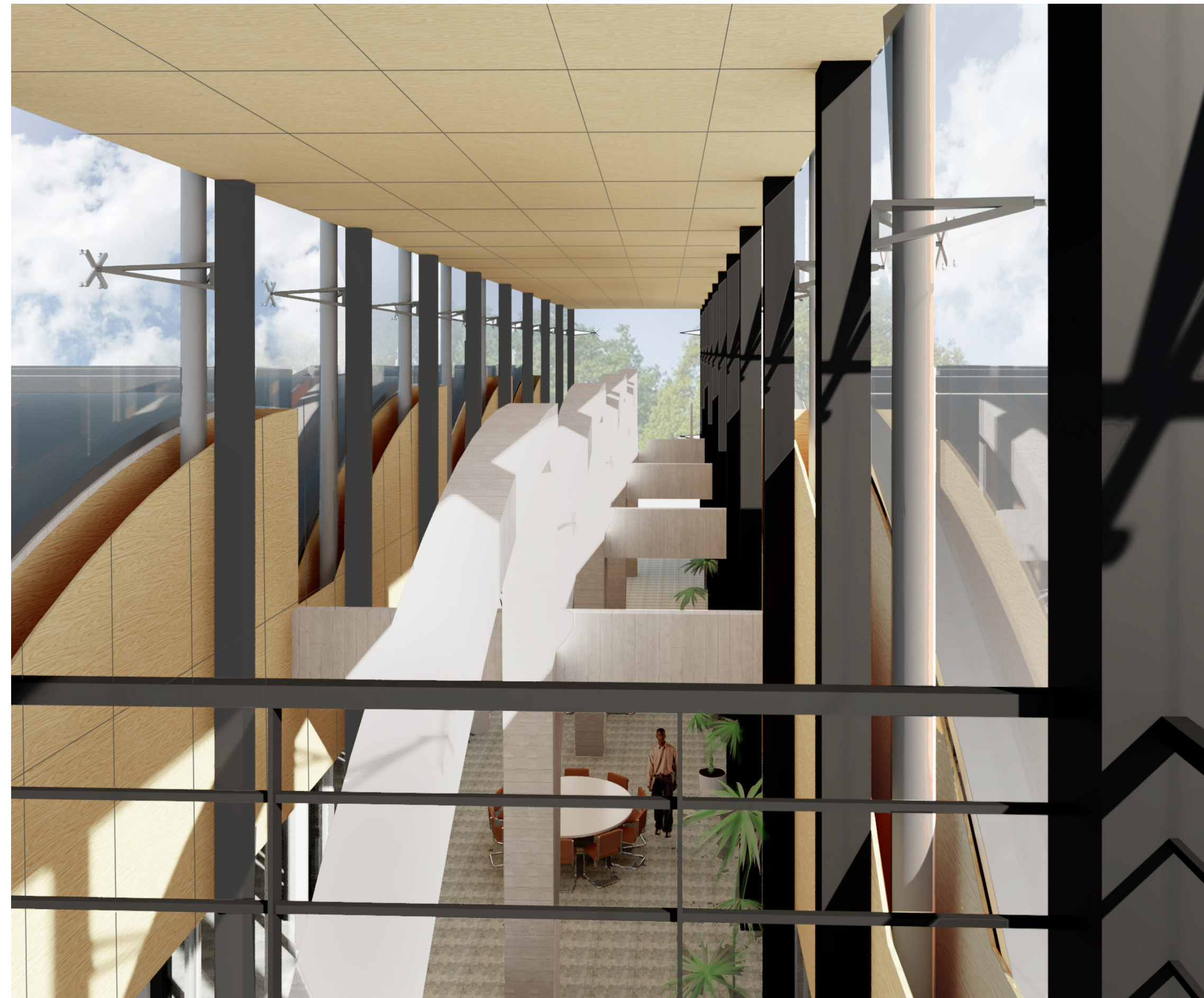

The Craftmanship Academy - impression view



The Craftmanship Academy - intervention structure

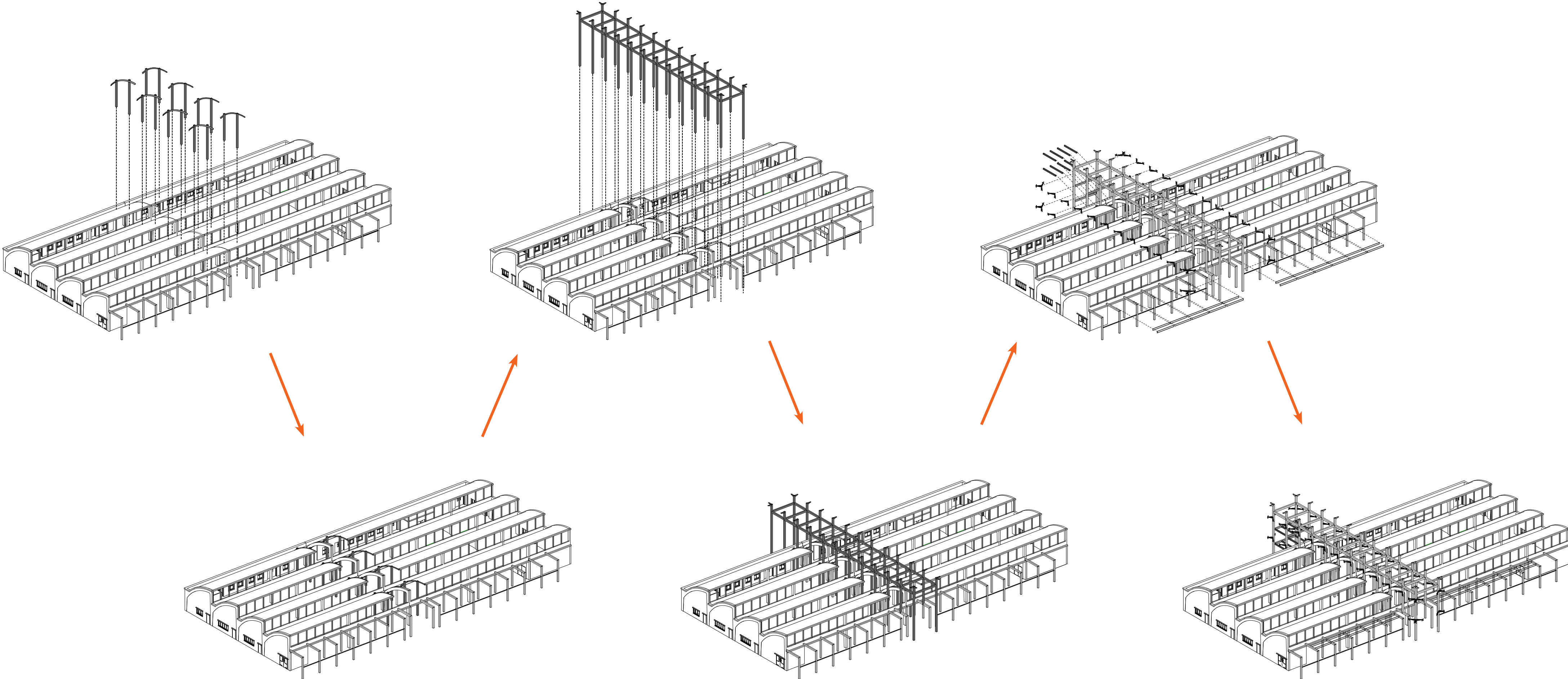

The Craftmanship Academy - intervention detail

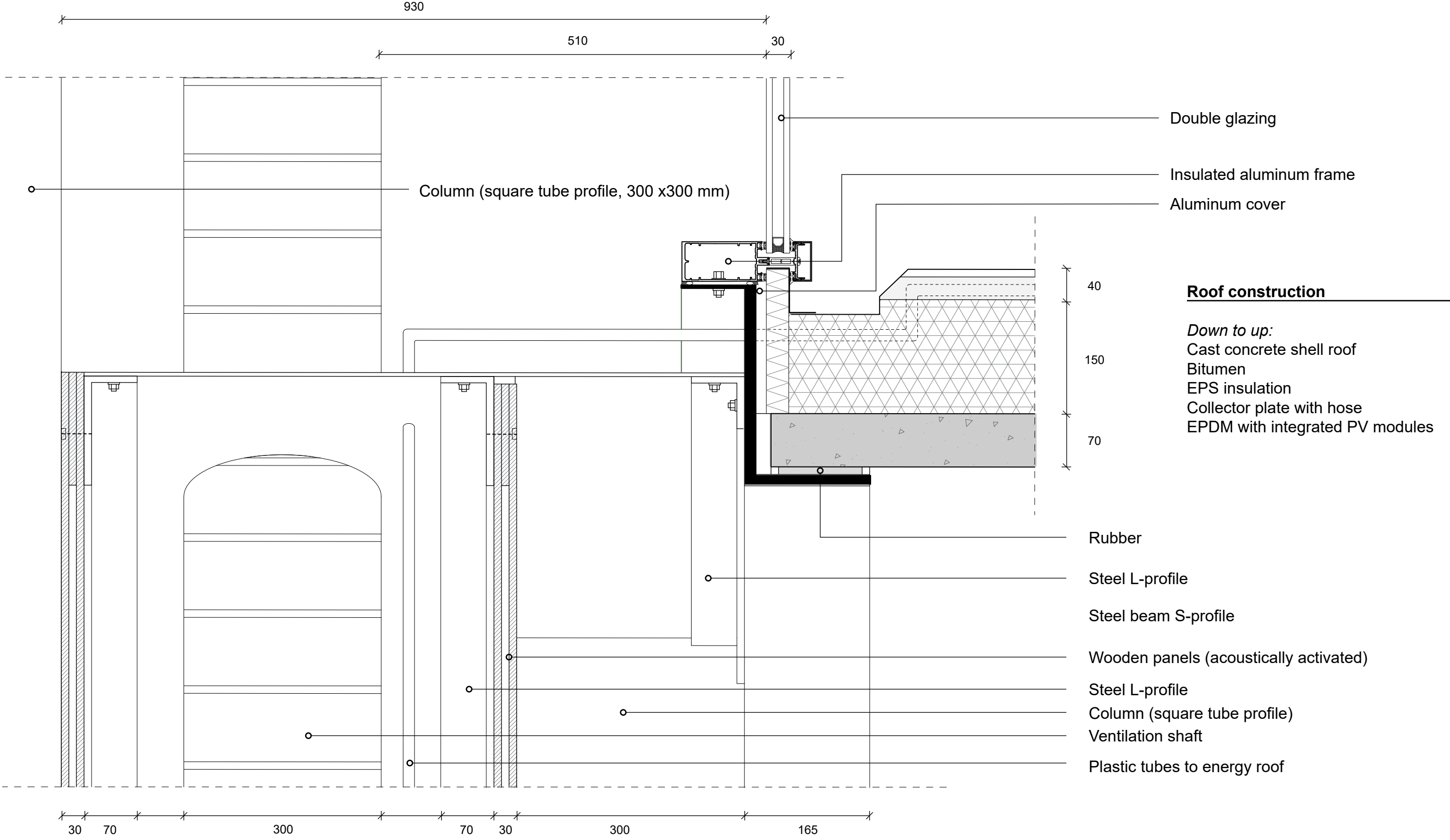
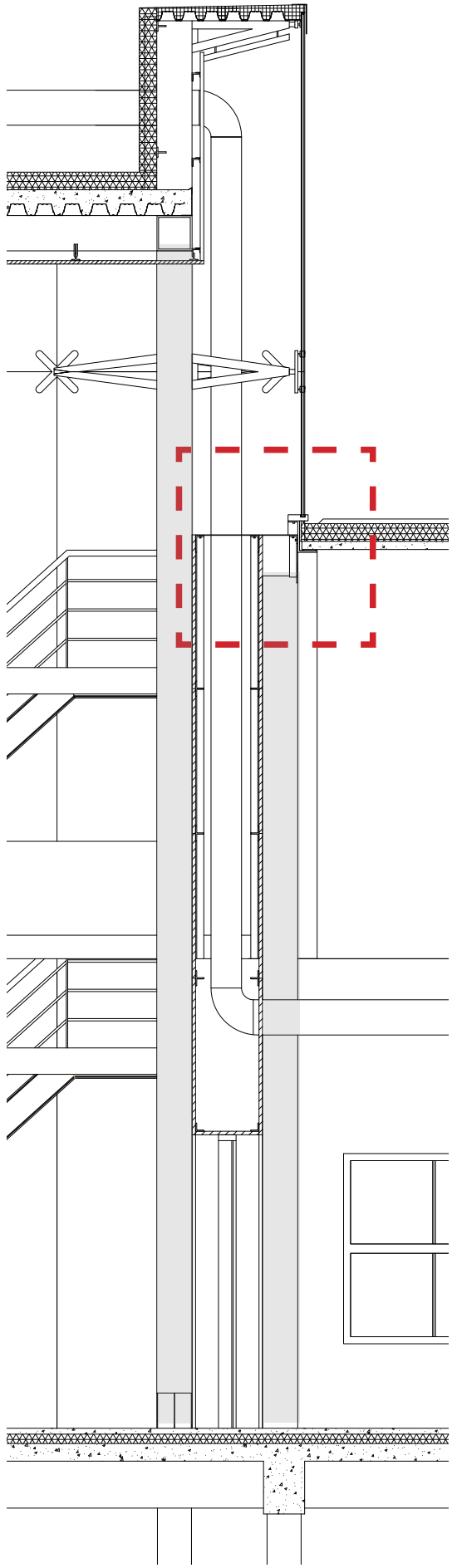

The Craftmanship Academy - ground floor



The Craftmanship Academy - impression workshops



The Craftmanship Academy - impression workshops



The Craftmanship Academy - frames

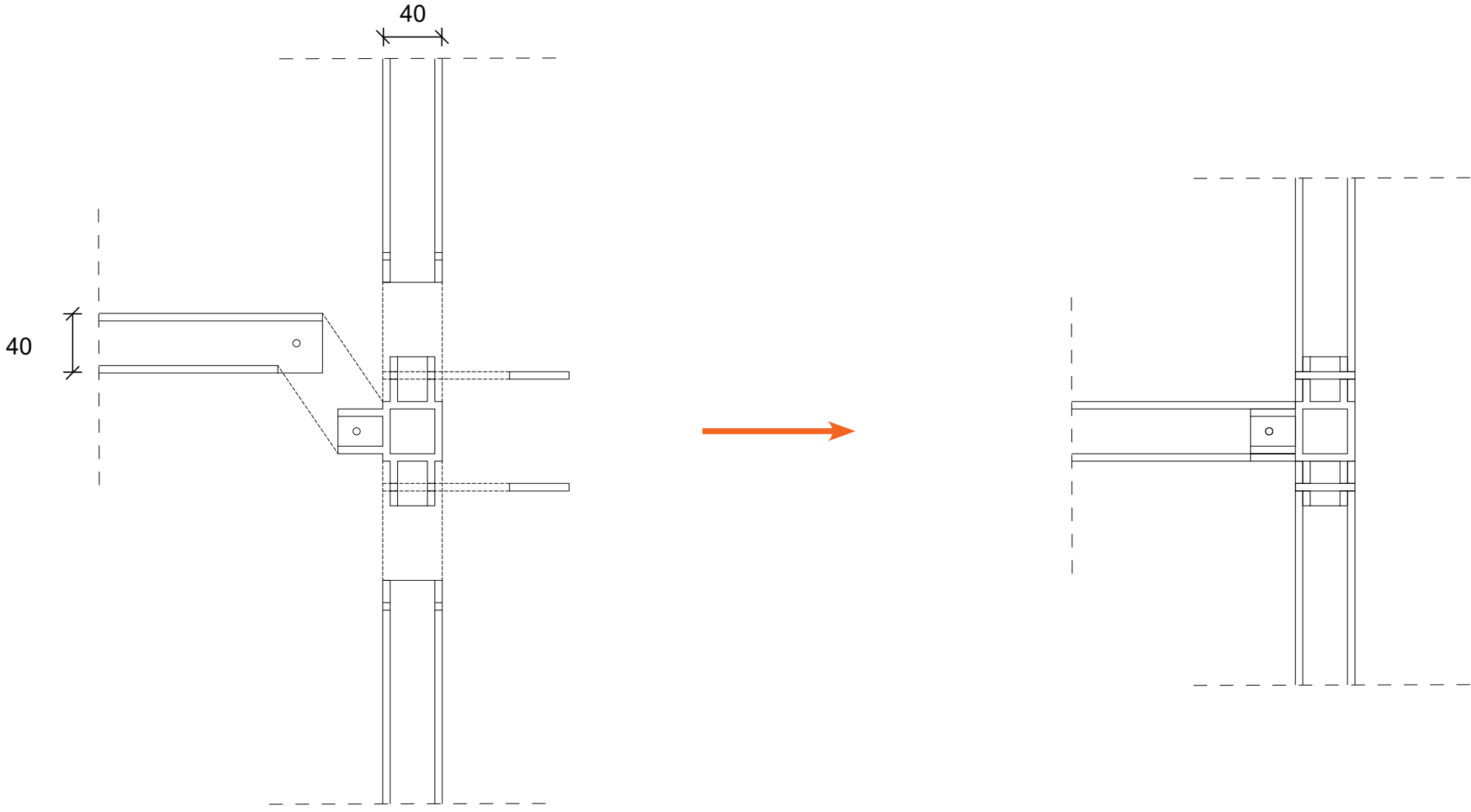
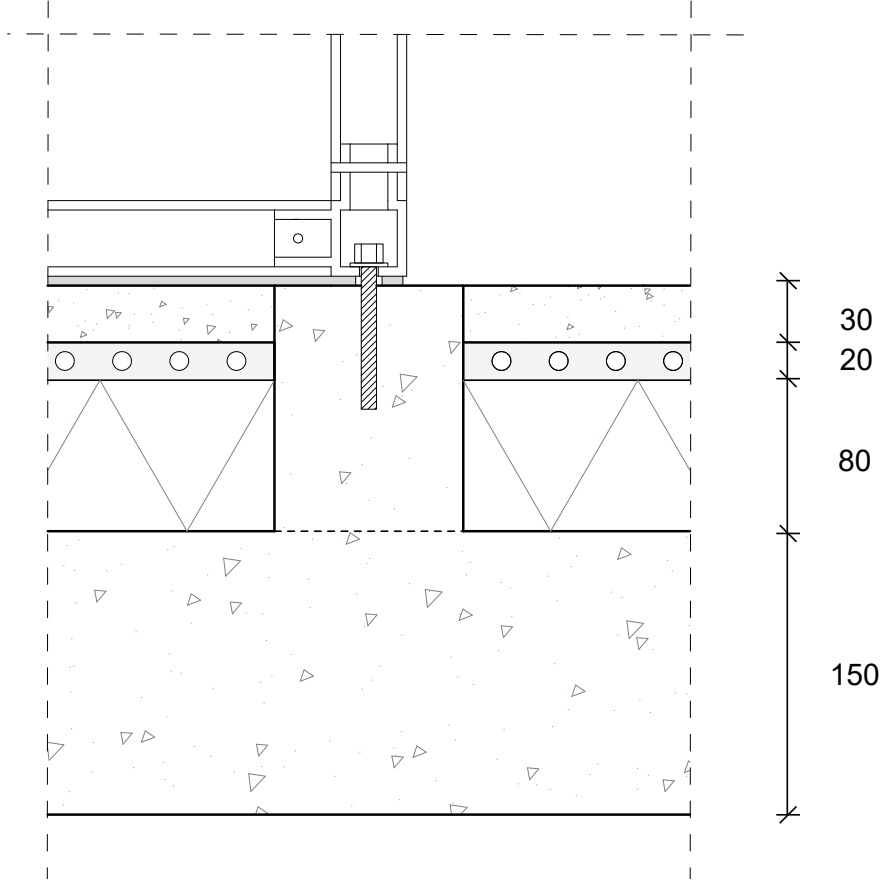
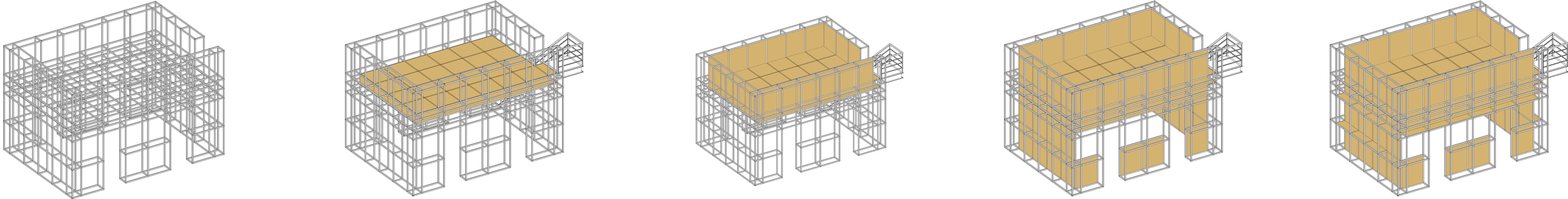

The Craftmanship Academy - frames

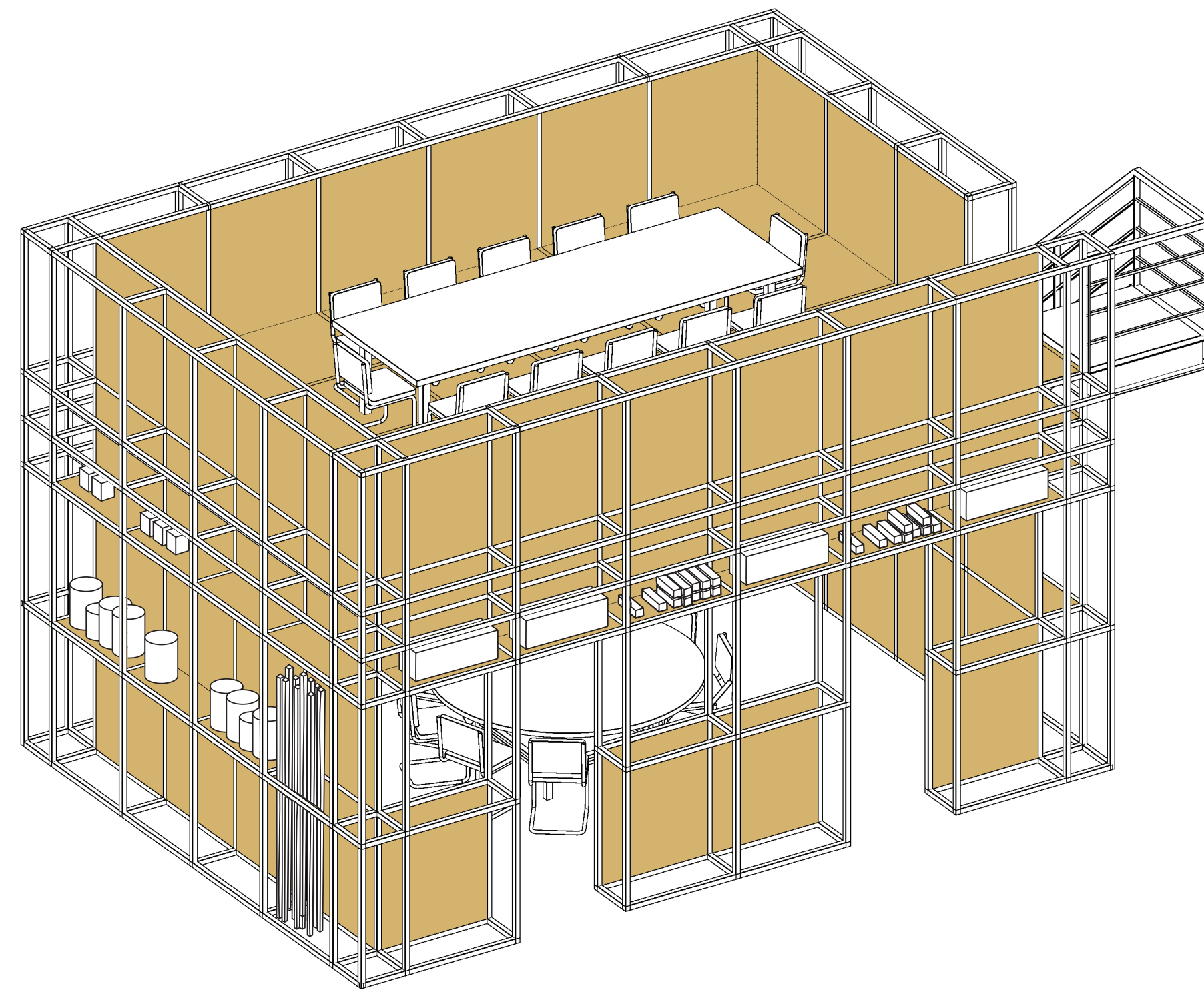

The Craftmanship Academy - section

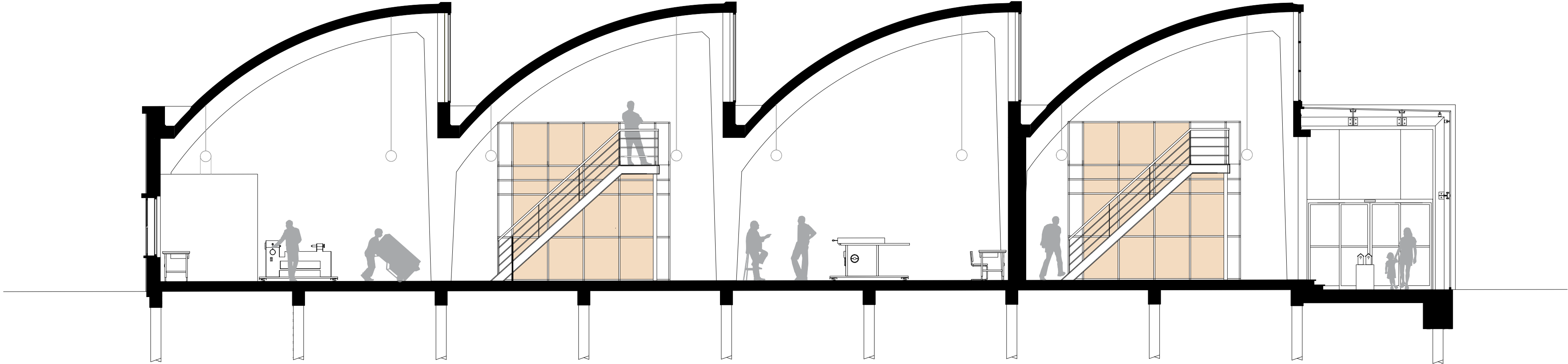

The Craftmanship Academy - impression frames

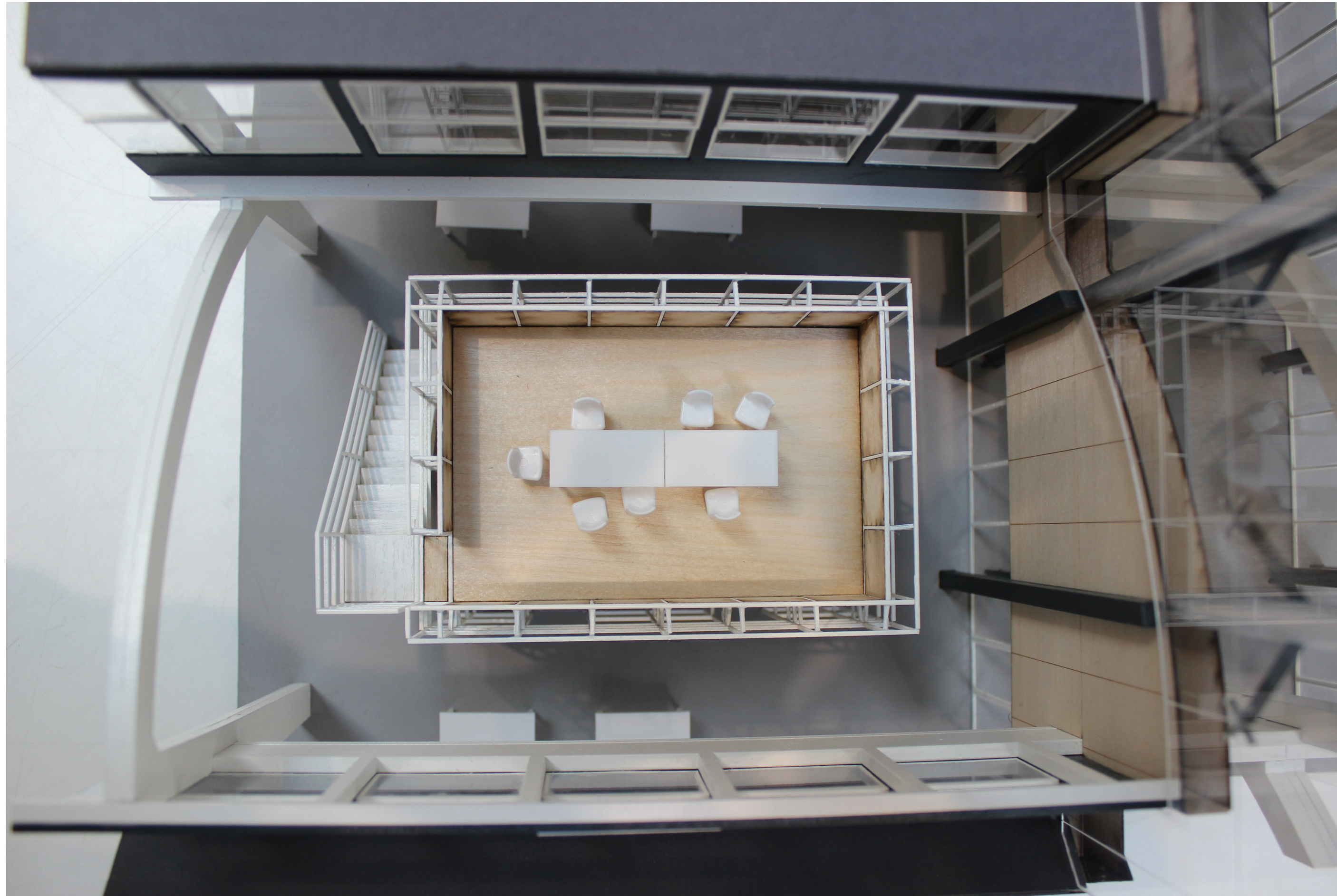

The Craftmanship Academy - section



The Craftmanship Academy - section

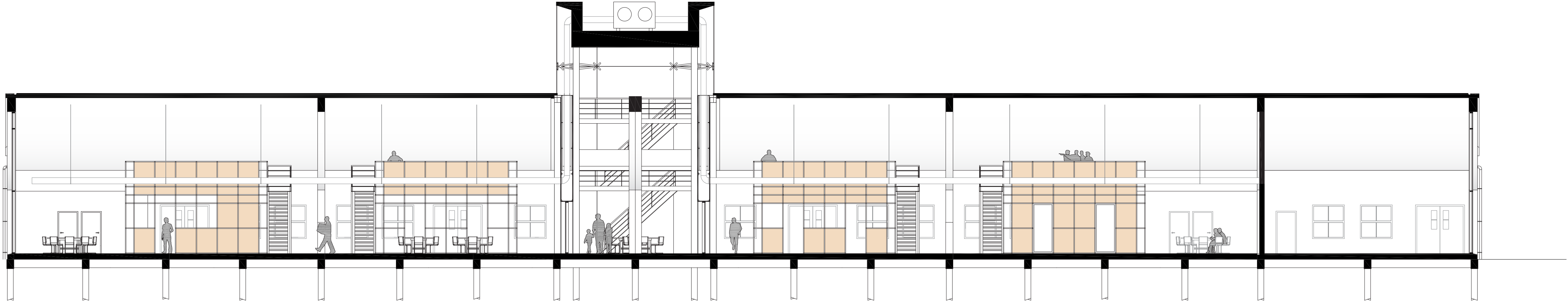

The Craftmanship Academy - ventilation

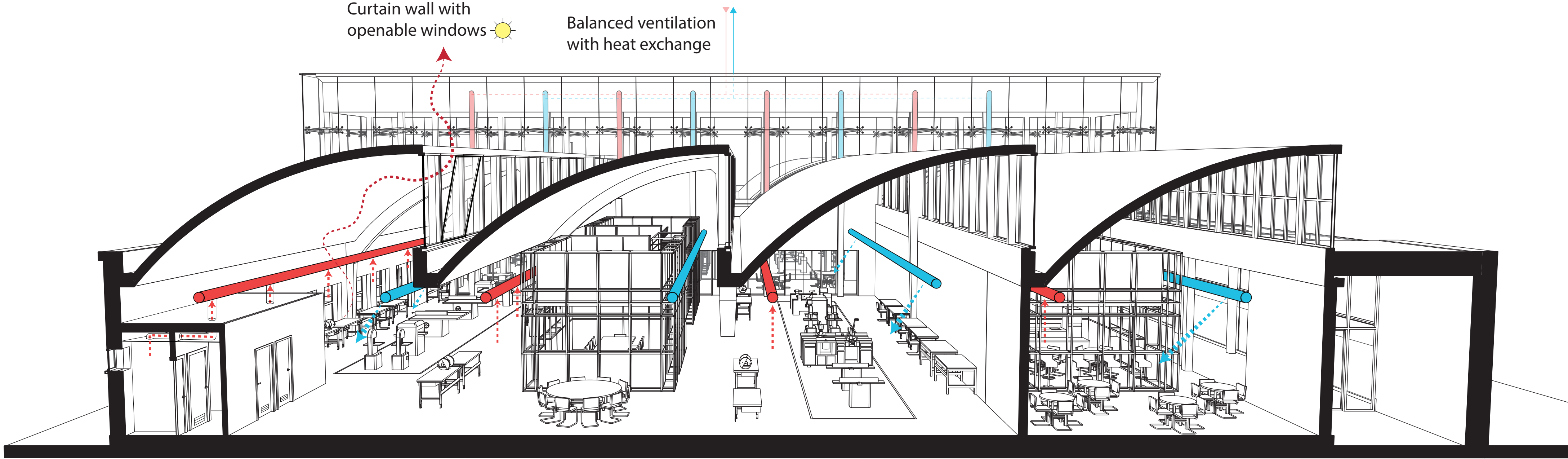

The Craftmanship Academy - insulation

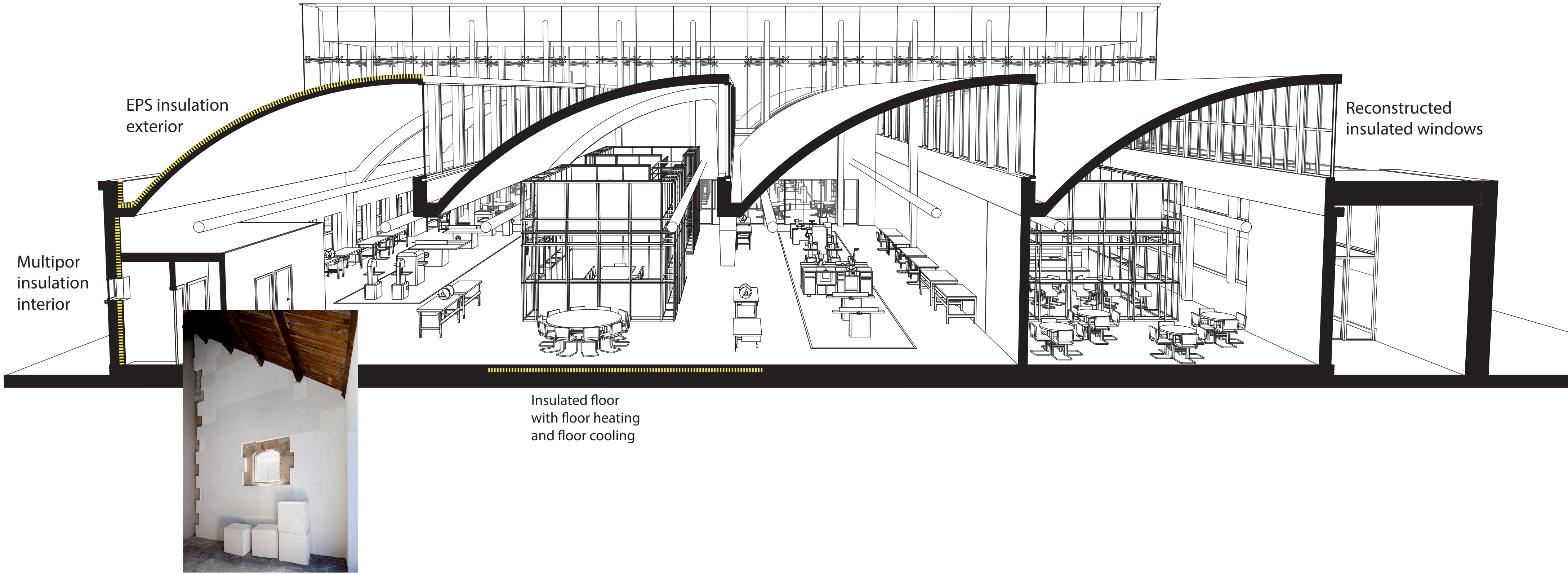

The Craftmanship Academy - heating

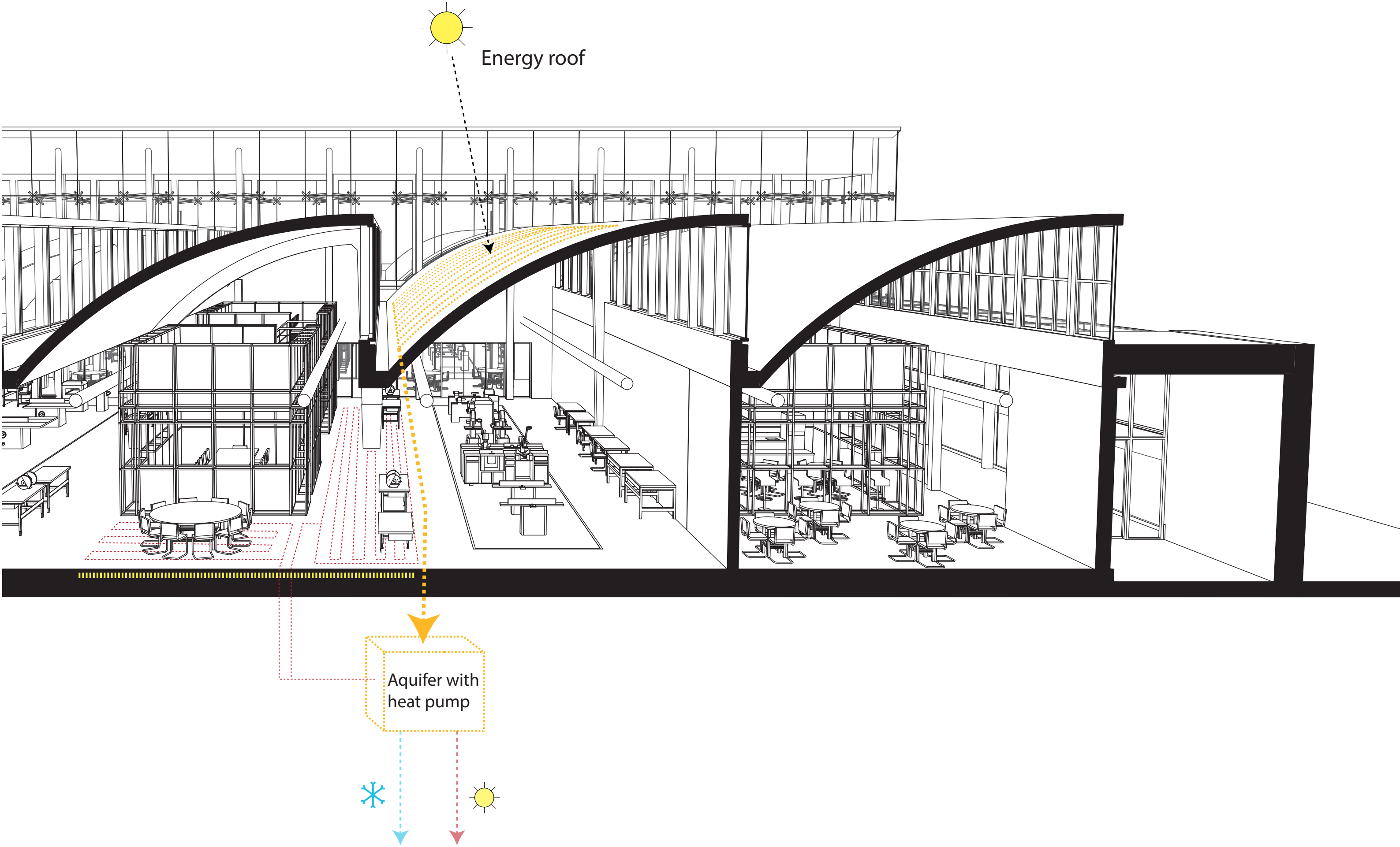
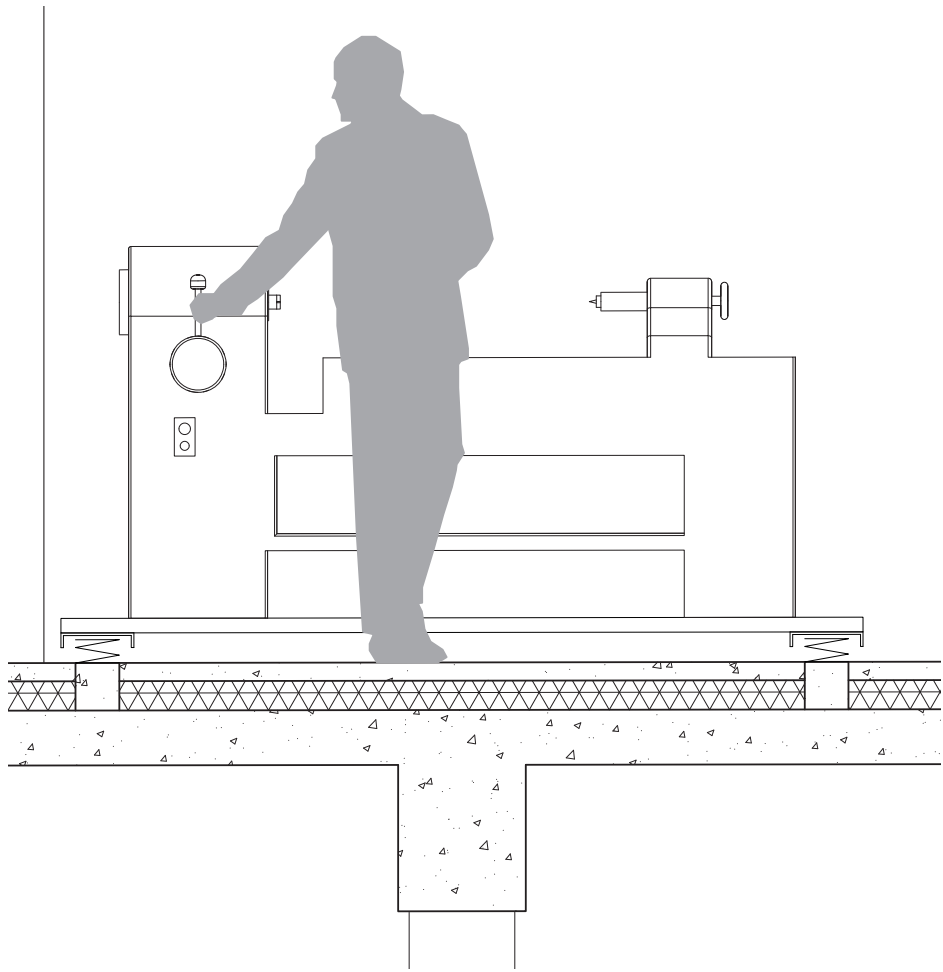
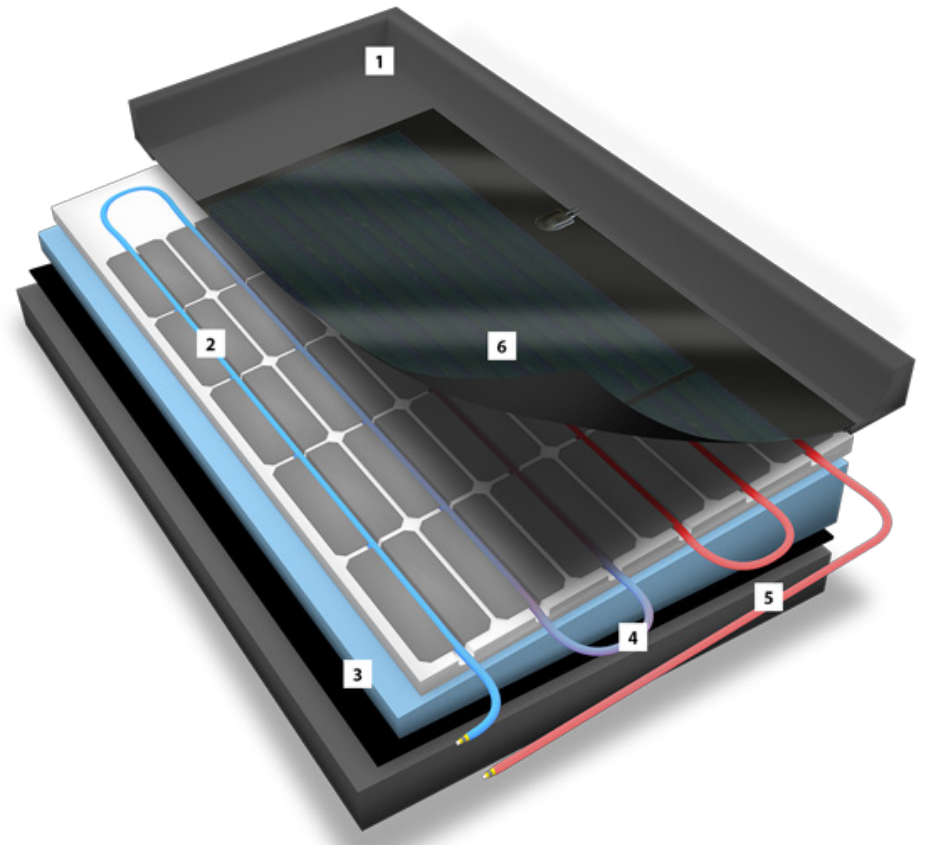

The Craftmanship Academy - water

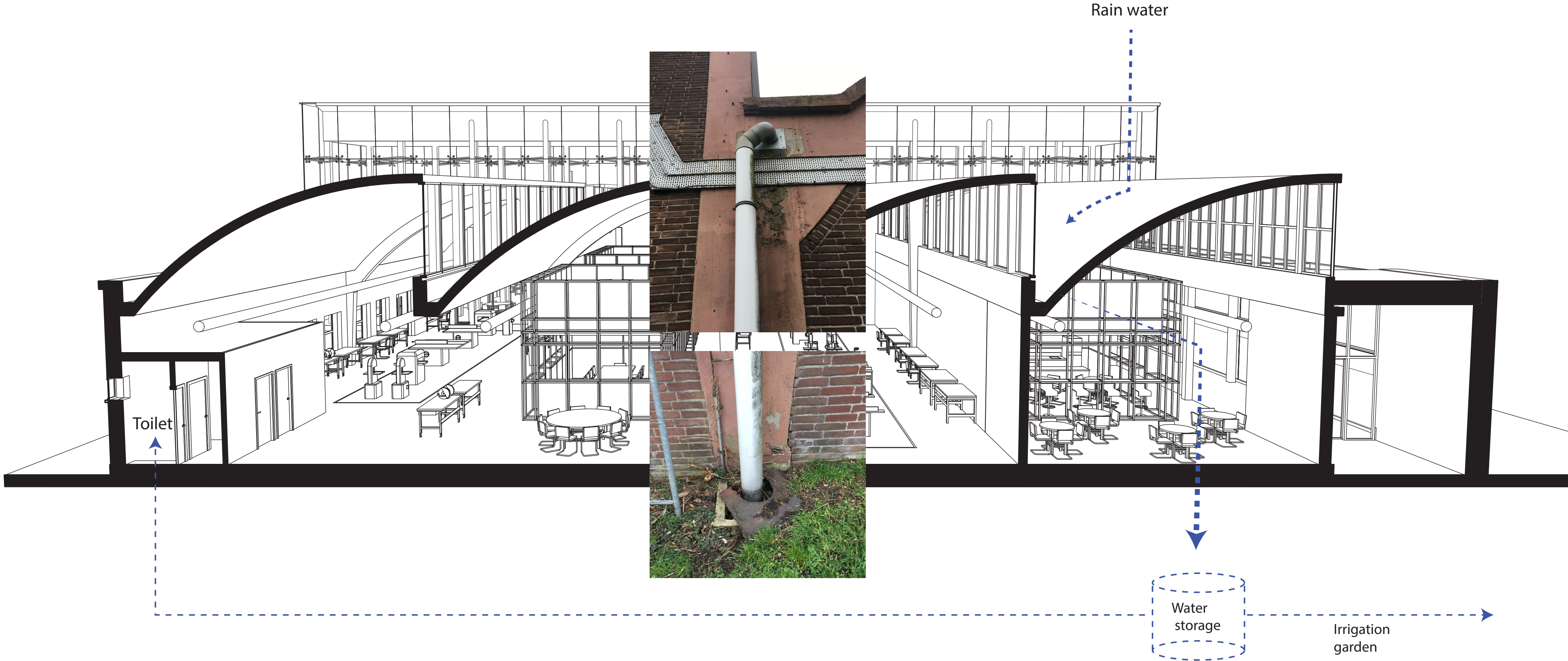

The Craftmanship Academy - climate design overview

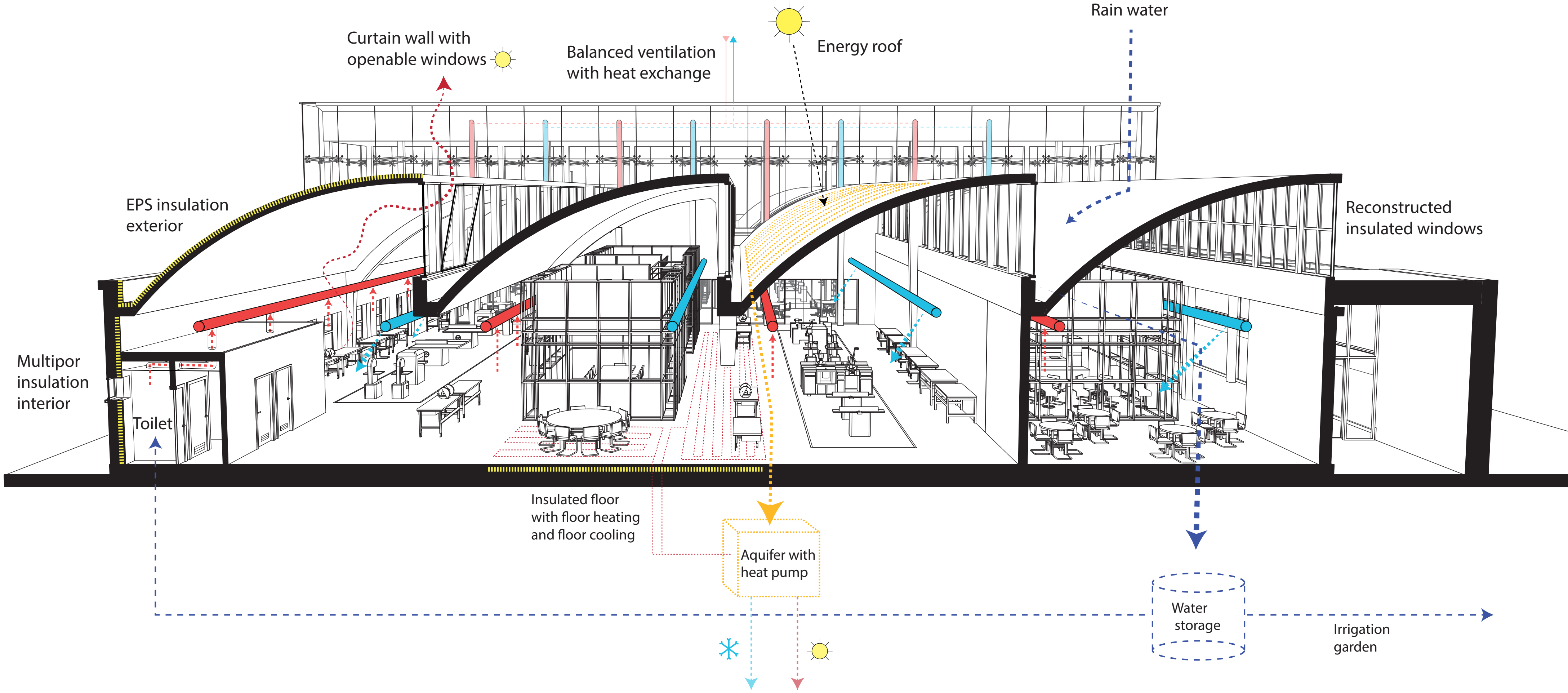

Reflection

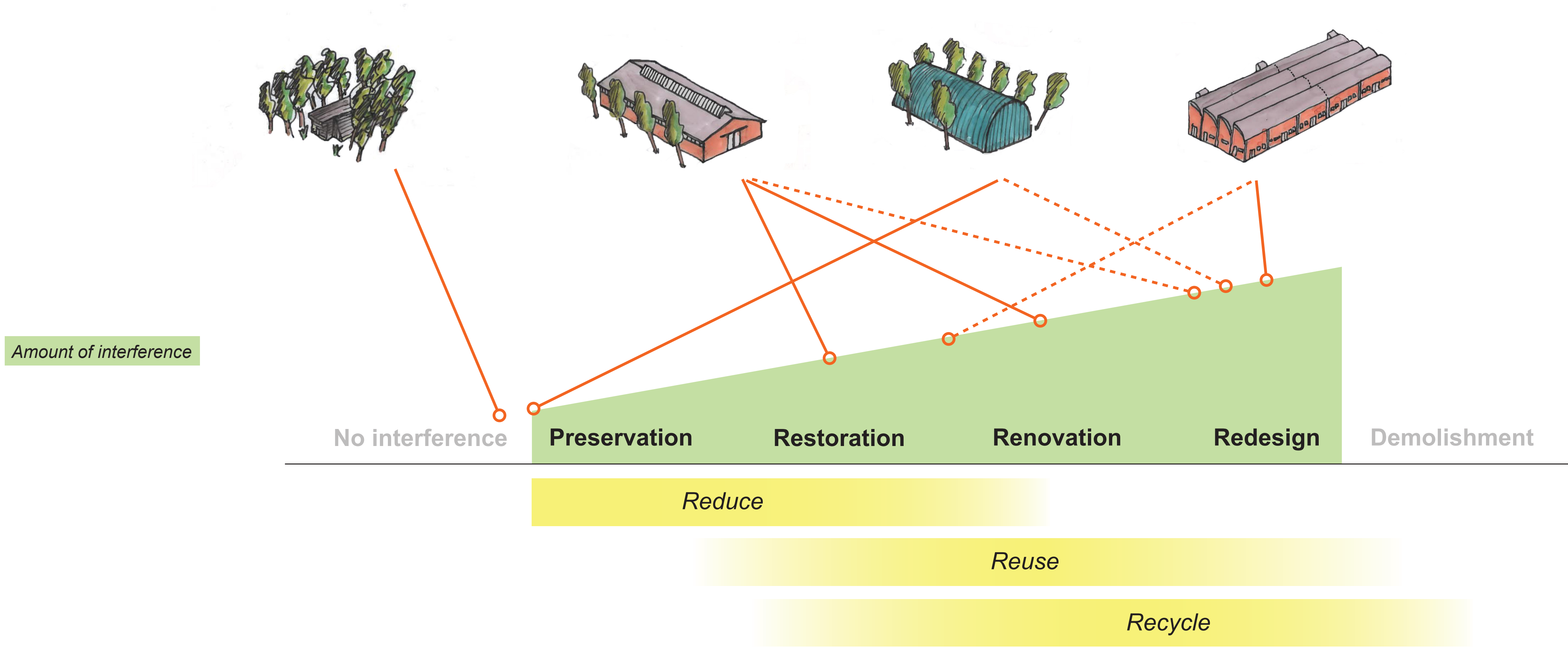



Questions