

Wireless sensor node with hybrid energy harvesting for air-flow rate sensing

Hu, Yushen; Yang, Jingchi ; Huang, Ziyu; Sokolovskij, Robert; Wang, Fei

DOI

[10.1109/ICSENS.2017.8234161](https://doi.org/10.1109/ICSENS.2017.8234161)

Publication date

2017

Document Version

Final published version

Published in

Proceedings of IEEE Sensors Conference 2017

Citation (APA)

Hu, Y., Yang, J., Huang, Z., Sokolovskij, R., & Wang, F. (2017). Wireless sensor node with hybrid energy harvesting for air-flow rate sensing. In *Proceedings of IEEE Sensors Conference 2017* (pp. 1-3). IEEE. <https://doi.org/10.1109/ICSENS.2017.8234161>

Important note

To cite this publication, please use the final published version (if applicable). Please check the document version above.

Copyright

Other than for strictly personal use, it is not permitted to download, forward or distribute the text or part of it, without the consent of the author(s) and/or copyright holder(s), unless the work is under an open content license such as Creative Commons.

Takedown policy

Please contact us and provide details if you believe this document breaches copyrights. We will remove access to the work immediately and investigate your claim.

Wireless sensor node with hybrid energy harvesting for air-flow rate sensing

Yushen Hu¹, Jingchi Yang¹, Ziyu Huang¹, Robert Sokolovskij² and Fei Wang^{1,3}

¹Department of Electrical and Electronic Engineering, Southern University of Science and Technology, Shenzhen, China

²Department of Microelectronics, Delft University of Technology, Delft, Netherlands

³State Key Lab of Transducer Technology, Shanghai Institute of Microsystem and Information Technology, Chinese Academy of Sciences, Shanghai, China

Email: wangf@sustc.edu.cn

Abstract—This paper presents a hybrid-powered wireless sensor node using enhanced triboelectric nanogenerator (TENG) as both energy harvester and air-flow sensor and two 11 cm² solar panels as extra power supply. A low budget commercial RF microcontroller is included for data conversion, signal processing and wireless transmission. The method of flow-rate detection depends on the vibration frequency of the film inside the triboelectric generator. Experiment results show that this flow sensor is capable of detecting flow rate from 7.6 m/s to 17.1 m/s, with a standard deviation of 3.4, 3s setup time and 30s charge time. With a Raspberry Pi, the wireless signal can be received and delivered to Internet and therefore, can be monitored easily from any portable terminal with internet-access.

Keywords—flow sensor, hybrid-powered, energy harvester, WSN

I. INTRODUCTION

Wireless sensor networks have a variety of application in environment surveillance and monitoring. However, most sensor node relies solely on batteries as power supply. This requires periodical replacement of battery which is neither economic efficient nor practical in cases where sensor is difficult to reach/track/locate. If it is impossible to replenish energy levels in the sensor nodes, the initial energy levels in the sensor nodes and ongoing energy consumption rates directly affect the operational lifetime and the data transmission capacity of the sensor network [1]. This fundamental limitation drives the research of energy autonomous wireless sensor node.

Recently, more and more researchers are looking for energy harvesting technologies to replace or provide supplementary power to the traditional batteries. Piezoelectric [2-4], electromagnetic [5-6] and electrostatic methods [7-10] were developed to harvest energy from vibration sources. In this paper, we provide a wireless sensor node powered by hybrid energy sources from both triboelectric nanogenerator and solar cell. Studies of how TENG harvests energy have been conducted in [11-14]. As shown in Fig.1, a soft film driven by wind periodically contacts the top/bottom layer. These layers and the soft film are fabricated with special material so that when they contact, the surface potential

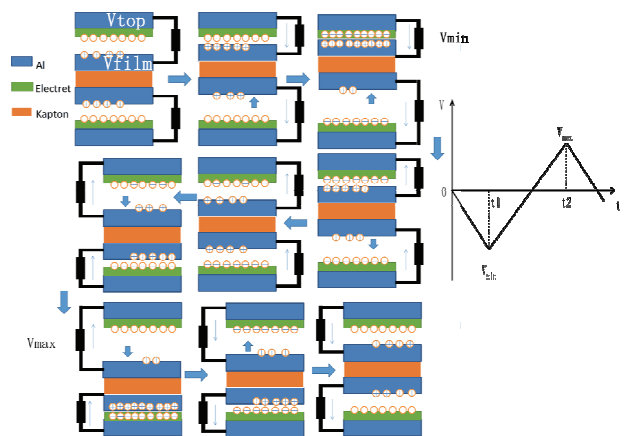

Fig. 1 Principle of TENG devices.

changes due to triboelectric effect. As a result, the voltage across the top/bottom layer and film serves as a voltage source.

Figure 1 illustrates the voltage V between the top layer and film. $V = V_{top} - V_{film}$. V_{min} corresponding to the moment (t_1) when film reaches the top layer. Similarly, V reaches maximum (V_{max}) when film contacts the bottom layer. Therefore, the vibration period of this film can be measured from the time period between two voltage peaks. Furthermore, vibration of film is due to vortex shedding effect. The relationship between film vibration frequency and flow-rate is well explained and examined in [11]. As a result, this device successfully bridges the connection between air-flow rate and measurable electrical signal.

II. METHOD

A. General structure

The circuit of the sensor node is shown in Fig. 2a, which is similar to our previous work shown in [15]. It can be divided into three parts: TENG and solar panels, power management circuit and micro controller. TENG is used as a power supply as well as a flow sensor to convert the air-flow rate to an electric sensing signal. Two 33×33 mm² solar panels are added as extra energy supply. Both TENG and solar panels are

This work is supported by National Natural Science Foundation of China (Project No.: 51505209), Shenzhen Science and Technology Innovation Committee (Projects No.: JCYJ20170412154426330 and KQTD2015071710313656), and Guangdong Natural Science Funds for Distinguished Young Scholar (Project No.: 2016A030306042).

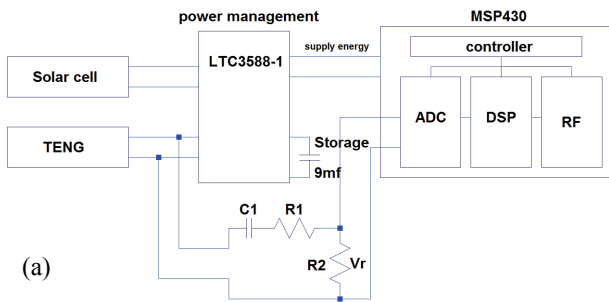

(a)

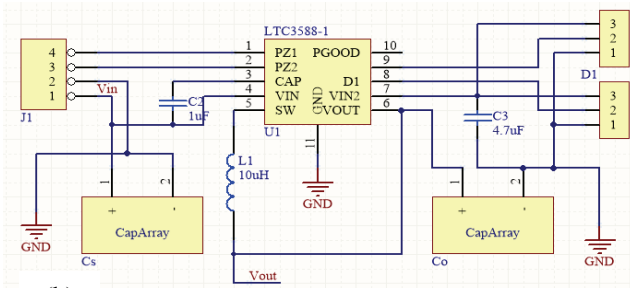

(b)

Fig. 2 a) wireless sensor node circuit. b) power management circuit.

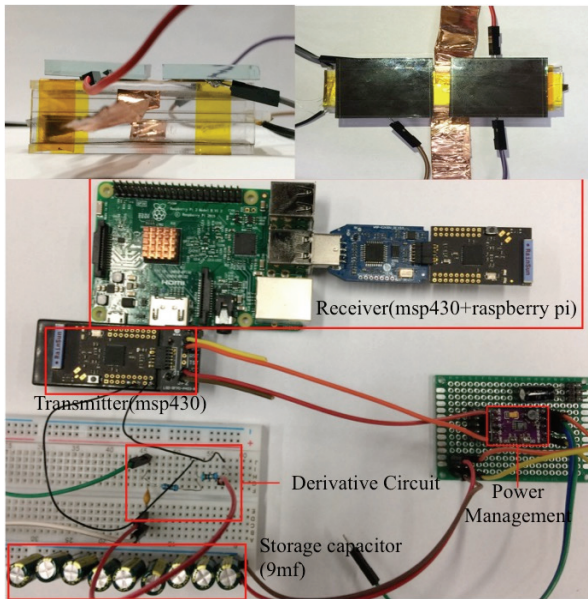

Fig. 3 (a) TENG with two solar panels with side view on the left and top view on the right. (b) Derivative circuit, MSP430, power management circuit and raspberry pi.

connected to the power management circuit and charge a capacitor (9mF) for energy storage. As shown in Fig. 2b, the power management circuit contains an energy harvesting controller LTC3588-1 and two capacitors C_s and C_o . C_s is the capacitor to store energy, C_o is connected to the ground and used for stabilizing the output voltage. Temperature data is directly delivered to RF module after data conversion while vibration signal requires more work.

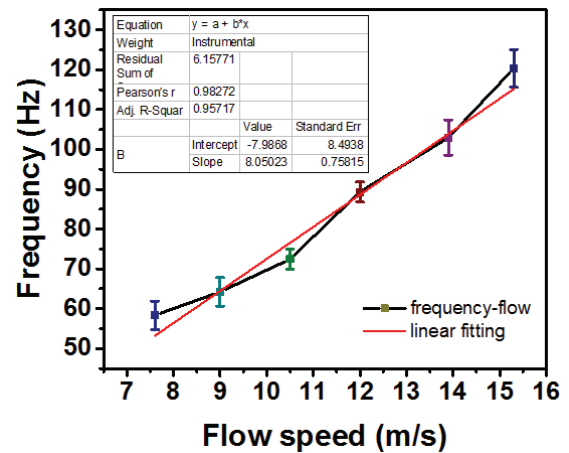

Fig. 4 Flow rate vs frequency.

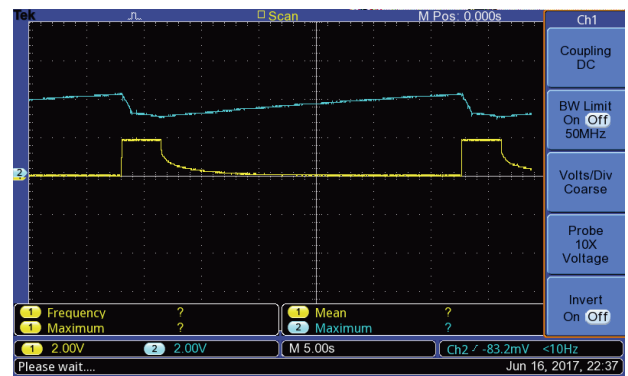

Fig. 5 Setup time and charge time. The blue line correspond to the energy storage capacitor voltage, the yellow line is the MCU input power supply voltage.

B. Vibration Frequency Analysis

To better reveal the vibration frequency, a derivative circuit with capacitor and resistor connected in series is added. A capacitor and two resistors are connected in series. The voltage across resistors corresponds to the derivative of the open circuit voltage. Resistor R_2 serves as a voltage divider, which constrains the voltage range to meet the requirement of data conversion. Fast Fourier Transform (FFT) and a linear sorting algorithm is implemented to generate the frequency spectrum of the film vibration and return the frequency with the maximum amplitude to the RF module, which is then transmitted to the receiver and upload to Internet by Raspberry Pi.

III. EXPERIMENT RESULT

In the practical experiments, two solar panels are packaged with the TENG, as shown in Fig.3a, are placed on a linear guide rail which can control the flow speed by moving the slider from a blowing machine.

A. Flow rate

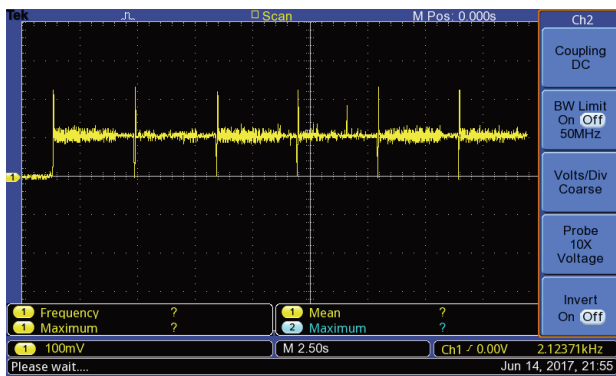

Fig. 6 Power consumption measurement. A 10-ohm resistor is connected in series with the sensor node in order to calculate the current.

Figure 4 presents the result of the frequency analysis method. The vibration frequency increases linearly with the flow rate with standard deviation of 3.4. Due to the memory size of CC430, the sampling size is chosen to be 256, and the sampling frequency is also set to be 256 Hz. This in return limits the maximum detectable frequency to 128 Hz.

B. Setup Time and Charge time

Due to the fact that frequency-analysis approach takes significantly long time (1s) for data sampling and Fourier Transform (2s), a large capacitor is required in order to meet the setup time requirement, which again further increase the amount of time for charging. As demonstrated in Fig. 5, once the voltage of the energy storage capacitor reaches the threshold (4.3V) (blue line), the power management chip will release energy to the MCU (yellow line). The MSP430 reads the data of the chip's internal temperature sensor and the voltage signal across the flow sensor. It takes 30 seconds for the hybrid energy harvester to charge the storage capacitor from indoor light. Better illumination condition will significantly reduce the charge time.

C. Energy Consumption

It is not easy to directly measure the input current. So we connect a 10-ohm resistor in series with the sensor node, and measure its voltage instead. We replace the solar panel and TENG with a DC power supply. The voltage across the resistor is shown in Fig.6 in order to calculate the current. The minimum working condition is 10 mA at 1.9 V, each operation consumes 60 mJ.

IV. CONCLUSION

Wireless sensor node has been widely used in various domain. In order to catchup with the increase demand in long lifetime working device, we propose an hybrid energy harvesting based flow-rate and temperature sensor. Combined with two 11 cm² solar panels and wind energy, the flow-rate and temperature detection can be self-powered during daytime. For low illumination use case, such as during the night or at the rainy weather condition, it can still maintain the temperature

monitoring function exclusively powered by wind.

In this paper we 1) establish quantitative relationship between air-flow rate and vibration frequency, 2) implement vibration frequency analysis approach for wind speed detection using a flow-driven triboelectric nanogenerator, 3) quantify the power consumption, setup time and precision, and 4) demonstrate a daily use case of this wireless sensor node for flow-rate monitoring. This frequency analysis approach consumes 60 mJ for each operation, requires 3 seconds to setup and can operate twice per minutes.

REFERENCES

- [1] Hu, Zhihua, and Baochun Li. "Fundamental performance limits of wireless sensor networks." *Ad Hoc and Sensor Networks* (2004): 81-101.
- [2] Lei A, Xu R, Thyssen A, Stoot AC, Christiansen TL, Hansen K, et al., editors. MEMS-based thick film PZT vibrational energy harvester. Micro electro mechanical systems (MEMS), 2011 IEEE 24th international conference on; 2011: IEEE. p. 125-8.
- [3] S. Li, et.al, "Bi-resonant structure with piezoelectric PVDF films for energy harvesting from random vibration sources at low frequency," *Sensors and Actuators A: Physical*, 247, 547-554, 2016.
- [4] S. Li, Z. Peng, A. Zhang, and F. Wang, "Dual resonant structure for energy harvesting from random vibration sources at low frequency," *AIP Advances* 6, 015019 (2016).
- [5] Tao K, Ding G, Wang P, Yang Z, Wang Y, editors. Fully integrated micro electromagnetic vibration energy harvesters with micro-patterning of bonded magnets. Micro Electro Mechanical Systems (MEMS), 2012 IEEE 25th International Conference on; 2012: IEEE. p. 1237-40.
- [6] Zhang Q, Kim ES. Vibration energy harvesting based on magnet and coil arrays for watt-level handheld power source. *Proceedings of the IEEE*. 2014;102(11):1747-61.
- [7] Suzuki Y. Recent progress in MEMS electret generator for energy harvesting. *IEEJ Transactions on Electrical and Electronic Engineering*. 2011;6(2):101-11.
- [8] Wang F, Hansen O. Electrostatic energy harvesting device with out-of-the-plane gap closing scheme. *Sensors and Actuators A: Physical*. 2014;211:131-7.
- [9] Y. Zhang, et.al, "Electrostatic energy harvesting device with dual resonant structure for wideband random vibration sources at low frequency," *Review of Scientific Instruments*, 87, 125001 (2016).
- [10] A. Crovetto, F. Wang, and O. Hansen, "Modeling and optimization of an electrostatic energy harvesting device," *IEEE/ASME Journal of Microelectromechanical Systems*, Vol. 23, No. 5, pp. 1141-1155, 2014.
- [11] Wang, Shuhua, et al. "Flow - Driven Triboelectric Generator for Directly Powering a Wireless Sensor Node." *Advanced Materials* 27.2 (2015): 240-248.
- [12] Wang, Shuhua, et al. "Elasto-aerodynamics-driven triboelectric nanogenerator for scavenging air-flow energy." *ACS nano* 9.10 (2015): 9554-9563.
- [13] Su, Yuanjie, et al. "Wind energy harvesting and self-powered flow rate sensor enabled by contact electrification." *Journal of Physics D: Applied Physics* 49.21 (2016): 215601.
- [14] Y. Wu, Z. Huang, Y. Hu, Z. Peng, X. Li and F. Wang, "Electret materials for enhanced performance of triboelectric energy scavenging from wind flow," in the *19th IEEE Conference on Solid-State Sensors, Actuators and Microsystems (Transducers 2017)*, 2017.
- [15] Y. Hu, Z. Peng, Z. Huang, Y. Wu, and F. Wang, "Event-Driven Wireless Temperature Sensor Networks Powered by Air-Flow Based Nanogenerator," in the *12th Annual IEEE International Conference on Nano/Micro Engineered and Molecular Systems (IEEE NEMS 2017)*, 2017.