

Keep It Cool: Reducing Energy Peaks of Reefers at Terminals

van Duin, JHR; Geerlings, H; Oey, MA; Verbraeck, A

Publication date

2017

Document Version

Accepted author manuscript

Published in

Transportation Research Board 96th Annual Meeting

Citation (APA)

van Duin, JHR., Geerlings, H., Oey, MA., & Verbraeck, A. (2017). Keep It Cool: Reducing Energy Peaks of Reefers at Terminals. In *Transportation Research Board 96th Annual Meeting* Article 17-00483 Transportation Research Board (TRB).

Important note

To cite this publication, please use the final published version (if applicable). Please check the document version above.

Copyright

Other than for strictly personal use, it is not permitted to download, forward or distribute the text or part of it, without the consent of the author(s) and/or copyright holder(s), unless the work is under an open content license such as Creative Commons.

Takedown policy

Please contact us and provide details if you believe this document breaches copyrights. We will remove access to the work immediately and investigate your claim.

1
2
3
4
5
6
7
8
9
10
11
12
13
14
15
16
17
18
19
20
21
22
23
24
25
26
27
28
29
30
31
32
33
34
35
36
37
38
39
40
41
42
43
44
45
46
47
48
49
50
51
52
53
54
55
56

Keep it cool: Reducing energy peaks of reefers at terminals

J.H.R. van Duin
Delft University of Technology/ Rotterdam University of Applied Sciences
Faculty of Technology, Policy and Management / Research Centre Sustainable Port Cities
Department of Engineering Systems and Services / Moving @ Rotterdam
P.O. Box 5015/ P.O. Box 25035
2600 GA Delft/ 3001 HA Rotterdam
The Netherlands
Telephone: +31-152781142/+31-624227649
E-mail: j.h.rvanduin@tudelft.nl/j.h.r.vanduin@hr.nl

H. Geerlings
Erasmus University Rotterdam
Department of Public Administration
Erasmus Smart Port
The Netherlands
Telephone: +31-104081886
Email: H.Geerlings@fsw.eur.nl

M.A. Oey
Delft University of Technology
Faculty of Technology, Policy and Management
Department of Multi-Actor Systems
P.O. Box 5015
2600 GA Delft
The Netherlands
Telephone: +31-1527864412
Email: M.A.Oey@tudelft.nl

A.Verbraeck
Delft University of Technology
Faculty of Technology, Policy and Management
Department of Multi-Actor Systems
P.O. Box 5015
2600 GA Delft
The Netherlands
Telephone: +31-152783805
Email: A.Verbraeck@tudelft.nl

Submitted on: November_11, 2016

Word count: Abstract (256) + Text (5989) + Figures/Tables (5*250) = 7495

1
2
3
4
5
6
7
8
9
10
11
12
13
14
15
16
17
18
19
20

ABSTRACT

The increase in population, high standards of living and rapid urbanization has led to an increasing demand for food across the globe. The global trade has made it possible to meet this demand by enabling transport of different food products from one part of the world to another. In this trade, refrigerated containers (reefers) play an important role, due to their ability to maintain the quality of product throughout the journey. However, the transportation and operation of reefers requires a constant supply of energy throughout the supply chain. This results in a significant energy consumption by reefers. When large numbers of reefers are involved, this results in high amount of energy consumption at terminals as well. From a terminal perspective, the monthly throughput of reefers shows a lot of variation due to the seasonality of food products. As a result, the growth of reefer trade, the seasonality of food trade and the special requirements of reefers has led to an increase in the peak power demand at terminals. Because utility companies apply extra charges for the highest observed peak demand, it is beneficial for terminals to keep this demand as low as possible to reduce energy costs.

To investigate the opportunities for container terminals to reduce their peak demand, an energy consumption simulation model is developed. With the model two energy reduction strategies are tested to analyze their impact on peak demand: intermitted distribution of power among reefer racks and restriction of peak power consumption among operating reefers. Both strategies show significant opportunities for cost reductions.

1. INTRODUCTION AND MOTIVATION

Transport plays a crucial role in modern societies. Much of the world's welfare today has been produced or at least facilitated by ports and its related activities: ports are the locations where trade, logistics and production converge. A well-functioning maritime transportation system facilitates the process of globalization and ongoing economic growth. This growth is especially reflected in the increase of container transport over the last decades. When we have a closer look at the process of containerization we observe some important developments. Firstly there is an increasing demand for 'conditioned transport' with a temperature that varies between -30 °C until 14 °C. The proportion of reefer market share in seaborne shipping transport increased from 47% in 1990 to 75% in 2014 and it is expected that for the coming 5-10 years the global growth will be around 8% per year [1]. This is partly due to the fact that the trade flow is no longer just the traditional trade flows from the Far East, but 'fresh' logistics chains are based more and more on production in Africa and Middle and South America. The reefers contain a wide range of products including perishable goods, such as flowers, fruits and vegetables, but also medicines and musical instruments. New conservation developments in conditioned transportation (as observed in the flower industry) makes a modal shift possible from fast air transport toward deep sea transport.

The growth in conditioned transport across the globe has led to a tremendous increase in the number of reefer fleets. This fleet increased from 294,000 TEUs in 1990 to 1,215,000 TEUs in 2005, signifying a growth of 313% over this period. By January 2012, this figure had reached 2,1 million TEUs. This rapid growth of reefers increased the market share of reefers in the total container fleet from 7% in 2012 to 11% in 2012 [2]. The seasonality of food products further affects the movement of these fleets. Many of these products have different temperature requirements leading to variation in power requirements of reefers. Furthermore, they are also highly sensitive to temperature variations leaving little bandwidth time to switch them off. The combination of the above has led to large amounts of energy consumption on terminals. In general, reefers are responsible for about 30-35 % of the energy consumption at terminals [3].

On these terminals, electricity is the primary source of energy used for reefer operations. This electricity is provided by an energy utility company. Due to seasonality of reefers, their energy demand over terminals is very volatile. This volatility in the energy demand pattern by reefers leads to a peak power demand. Peak power in energy demand management is a period in which electrical power is expected to be provided for a sustained period at a significantly higher than average supply level. Peak power fluctuations may occur on daily, monthly, seasonal and yearly cycles. This leads to excessive energy costs due to additional peak charges applied by utility companies. Despite, these peak power and excessive energy costs, energy efficiency measures and strategies are rarely present in ports and terminals [4]. The stringent norms on product quality and the bounded rationality faced by terminal operators further add to the complexity of efficient energy management of reefers. Thus, efforts are needed to reduce the energy costs by lowering the peak power consumption of reefers while ensuring the stringent temperature requirement of products inside reefers. This leads to the following research objective:

'To investigate the possibilities for peak shaving the electricity demand at reefer stack by applying new rules of operation for modus operandi of reefers, while monitoring its impact on the reefer temperature'

Based on the research methodology by Sargent [5], this paper is structured in 5 sections. Section 1 provides information on the research topic followed by the research objective. Section 2 provides a literature review on current energy saving models followed by the knowledge gap. In Section 3, following the description of reefer operations, the conceptual model for energy consumption of reefers is developed. Specification, verification and validation of the model are also included. In Section 4, peak shaving opportunities will be discussed followed by their analysis and implications. Conclusions are given in Section 5.

2. A LITERATURE REVIEW ON METHODS FOR ENERGY CONTROL OF REEFERS

A reefer unit consists of hardware components such as thermal insulation and gratings, and software component such as technology used for the control of refrigeration. Consequently, the two developments concerned with improving the energy efficiency of reefer units are: hardware improvements and software solutions.

Zsembinszki et al. [6] carried out a numerical model evaluation of the reefer which uses phase change material as a cooling component in the compressor. The major input variable considered in addition to container size is the thermal conductivity of the material of the container. Further research involves the proposition to use carbon nanotubes as insulation for reefers. However, hardware solutions have reached their potential limit, unless a major breakthrough occurs in material science.

A majority of the energy saving models in reefers deal with optimization of the software that runs the refrigeration unit. Sorenson [7] has investigated the potential for reduction in energy consumption on a sample Star Cool reefer by the introduction of modern control methods, without compromising the quality of the transported goods. He developed a non-linear dynamic simulation with the implementation of controller unit, which combines

1 the thermal inertia of cargo and ventilation rate to determine the actual demand for potential reduction in energy
 2 consumption of reefers. Another successful energy saving model for reefers is 'QUEST' (QUALITY and ENERGY
 3 efficiency in STORAGE and TRANSPORT of agro materials), which is a software solution to improve the control of
 4 refrigerated marine container (reefer) units, with the objective of maximizing the energy efficiency in chilled mode
 5 operation by optimizing evaporator fan speed with the load, without impairing produce quality [8,9]. The two
 6 models mentioned [7,8,9] are based on the individual working of reefers. However, they do not take into account a
 7 system of reefers operating at terminals. For this, a system named Reefer Monitoring and Control System
 8 (REFCON) has been developed. It is the automated control system that remotely monitors the conditions of reefer
 9 containers – during transportation onboard the containership and during storage at the container terminal. A reefer
 10 with a modem communicates its status to controller which sends the signal to the screen via transmission cable [10].
 11 The information displayed on the screen are the temperature indicators, especially the return air temperature and set
 12 point temperature. When a large deviation of return air temperature from set point is observed, the reefer handler
 13 will inspect it. This system enables safe transportation of cargo and transparency in shipping operations. A two-way
 14 communication takes place between the operator and every single reefer [10].

15 'Peak Shaving' is the technique to reduce electrical power consumption during periods of maximum
 16 demand on the power utility. Some of the techniques available to reduce peak demand are as follows:

- 17 • Load Shedding involves turning off non-critical loads during peak hours or operating non-critical loads
 18 only during non-peak hours;
- 19 • Peak Sharing uses a generator to power a portion of the facility electrical load. A generator can also be
 20 used to power non-critical loads during peak hours;
- 21 • Power Sharing involves intermitted supply of power for the cooling operations of reefers.
 22

23 It is common for a facility utilizing peak shaving techniques to have net energy savings of 10% to 30% of
 24 their electricity bill [11].

25 Modeling is being used to support the design and optimization of refrigeration systems. Over the years,
 26 many models have been developed to understand the working of a reefer and thereby develop energy saving
 27 solutions. The fundamental concept of these models is the basis energy balance equation. Using this as foundation,
 28 several approaches such as spatial temperature difference models and heat flux models have been developed to gain
 29 an in depth understanding of the reefer system [12]. Though there are several techniques available for determining
 30 energy consumption, the methodology adopted in this research is simulation modeling.

31 In simulation modeling, Computational Fluid dynamics (CFD) has been the most widely used technique
 32 for modeling energy consumption of reefer [12]. Jedermann et al. [13] however, follow a different approach. They
 33 developed linear dynamic differential equations in Matlab software to study the energy consumption of reefers.
 34 Sorenson [7] has used simulation environment such as TRNSYS, Matlab and Simulink to model the complex
 35 refrigeration system of reefers. These models, however, fail to determine the impact of energy consumption. Several
 36 simulation models have been developed to understand the complex terminals operation. Lutjen et al. [14] has used
 37 network model to study the interactions between different agents of logistics such as vendors, distributors and ware
 38 houses. The model consists of nodes and transport relations among these agents. Hartmann [15] has used discrete-
 39 event based simulation to understand the container logistics for the entire terminal. The model is built in the
 40 emPlant simulation software. The model captures the dynamics of logistics of the containers between different
 41 physical resources. These simulation models include the frequency and transport related parameters along with the
 42 container parameters. Operations research (OR) models are used to determine the optimal fleet size and optimal
 43 operation schedules. However, the focus of these models is on the logistics side and they ignore the energy
 44 consumption of reefers.

45 Simulation models have also been developed to study the energy consumption at terminals. Saanen et al.
 46 [16] have used heat mapping technique to simulate the CO₂ emissions RTG terminal. This is especially helpful in
 47 understanding the energy and environmental impacts of different terminal operation in much detail. However, this
 48 model though extremely useful, deals with only large objects and focusses more on the CO₂ emission. Abadi et al.
 49 [17] use an object-oriented simulation system developed in C# programming language to develop a macroscopic
 50 model of terminal. It consists of objects such as the terminal itself, trucks, trains and ships. Other minor objects such
 51 as various yards, different types of cranes are contained within the terminal object. However, this model does not
 52 track the movement of the reefers at the terminals.

53 Based on the literature review we have identified knowledge gaps dealing with the dynamic visualization
 54 of energy consumption by a system of reefers operating at terminals and appropriate peak shaving techniques to
 55 save energy bill. Earlier studies emphasize the energy saving models for a single reefer and a reefer temperature
 56 control system at the terminal. It also provides a list of different peak shaving techniques. However, it lacks the
 57 following elements that form the basis of the knowledge gap:

- 58 • Most of the models deal with energy consumption of reefers on an individual basis. Reefer Monitoring
 59 and Control Systems provide mainly information about the temperature of system of reefers. Hence, a
 60 detailed study is lacking about the energy consumption of a system of reefers connected at terminals.
 61 This includes the interconnection between the terminal operations and the temperature increase of

reefers. For this, the research deals with the terminal logistics, its impact on reefer temperature and thereby the energy consumption at terminals;

- Existing models do not take into account the sensitivity of various factors on the energy consumption of reefers. Hence, in our model a sensitivity analysis for a single reefer and for a system of reefers are performed. This will give insight into the key decision variables for determining the energy consumption of a reefer;
- Many studies confirm the occurrence of power peaks at terminals due to reefer operations. Several peak shaving techniques are also available to reduce peak power demand. However, there is a lack of study of how to incorporate these peak shaving solutions for peak power demand by reefer terminals. Hence, this research will provide details of the peak power consumption by reefers followed by the opportunities to reduce these peaks;
- Grid operators calculate the electricity price for container terminals partly based on the peak energy consumption of terminals. The greater the observed peak, the higher the energy costs. The challenge for container terminals is therefore to smoothen their peak demand over time to prevent high peaks leading to savings in energy bill. However, the financial savings due to peak reduction are unknown. This research, thereby, presents the savings by a terminal due to peak power reduction.

3. TOWARDS THE CONCEPTUALISATION, SPECIFICATION AND CONSTRUCTION OF THE REEFER ENERGY CONSUMPTION MODEL

In order to determine the relationships between the terminal logistics and reefer containers, it is important to identify all the terminal processes, which are divided into three phases: Incoming, Dwell Time and Outgoing. In the incoming phase, the ship carrying reefer containers arrives on the quay side. The reefers are, then, unplugged on ships and transported on the terminals by means of quay cranes. During the dwell time phase the containers are stacked in reefer racks, plugged into electrical sockets and checked for their temperature settings according to the bill of lading information supplied by the shipping line [18] with the usage of the terminal equipment. They are stored in special reefer blocks. Continuous supply of electricity is ensured by them plugging them into electrical sockets for their respective dwell time. Finally, in the last phase, they are plugged out of sockets, loaded onto trucks, trains or barges and transported to hinterland. The related IDEF0-schemes [19] can be found in Nafde [20]. In theory the process could also be the other way around as well, but the model can be easily adapted to differences in sequences.

3.1. Conceptualization of reefer model during its unplugged time

The IDEF0-schemes have identified all terminal processes, concerning the handling of reefer containers. It is important to study the impact of these processes on the reefer temperature. This will help determine the temperature fluctuations in reefers. These fluctuations have great impact on the initial power requirement of the reefers. Figure 1 gives a sample temperature profile for the transport of fishes from Iceland to France. As seen, as the ship arrives on the terminal and the reefers are plugged out, there is a rapid increase in their temperature. This is because there is a certain time period where a reefer is without power supply (Unplugged time) which affects its temperature. In this case, the temperature of the reefer increased from 0.5 °C to 6 °C for a period of eight hours without electric supply.

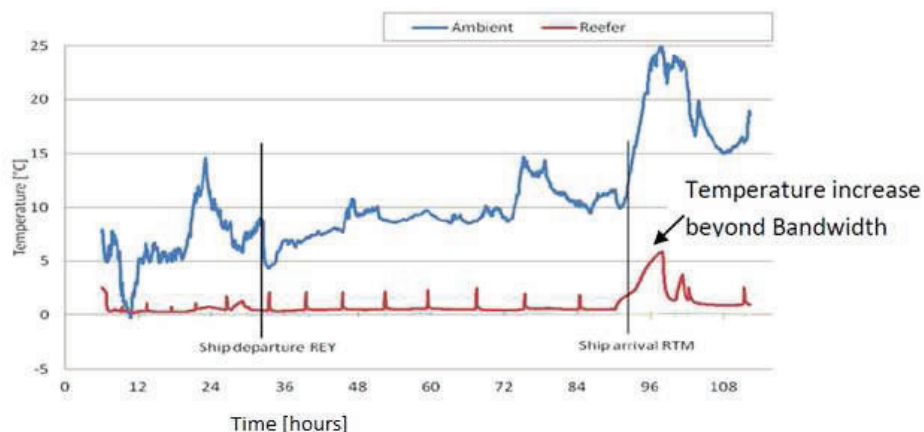

FIGURE 1 TEMPERATURE PROFILE OF A REEFER [21]

1 Based on the literature study, the most comprehensive equation to model the temperature increase is
2 defined as follows

$$\Delta T(t) = \Delta T - \Delta T * \exp(-(A*k*t*(1+S))/(m*C_p)) \quad (1)$$

3
4
5 Temperature increase of reefer [22]
6

7 Where

8 $\Delta T(t)$ = Temperature Effect in Time ($^{\circ}C$)
9 ΔT = Ambient Temperature - Return Air Temperature ($^{\circ}C$)
10 A = Surface Area of Reefer (m^2)
11 K = Thermal Insulation of Reefer ($W/m^2.^{\circ}C$)
12 t = Time before plugging in at reefer stack (Seconds)
13 S = Exposed sun intensity (no dimension)
14 M = Mass of Cargo (kg)
15 C_p = Specific heat of cargo ($kJ/kg.^{\circ}C$)
16

17 As seen, the equation covers different types of variables affecting the energy consumption of reefers.
18 Hence, this equation is in line with variables affecting the cooling power of reefers (see Formula 2). Formula (1)
19 gives the temperature rise of reefers during its unplugged time. Once, the reefer arrives in stack, it is plugged it and
20 the temperature settings are checked. The reefer starts consuming energy from this moment.
21

22 3.2. Conceptualization of reefer model during its plugged-in time

23 With Formula (1) the temperature fluctuation of a reefer is calculated before its plugged-in. The return air
24 temperature of reefer rises correspondingly during this period. Once a reefer arrives in stack and it is plugged it, the
25 return air temperature may show deviation from the recommended set point temperature. First it is checked whether,
26 due to temperature fluctuation, the return air temperature is outside the allowed bandwidth. This point is shown in
27 Figure 1. Based on this three conditions are possible:
28

- 29 • *Return air temperature is beyond the upper limit of the allowed bandwidth*

30 In this case, there is great risk of damage to cargo due to overheating [23]. Thus, there is urgency to bring
31 the reefer back to its set point temperature. Hence, rapid cooling occurs to bring the reefer to this
32 temperature. During this process, in addition to usual auxiliary power, maximum amount of cooling power is
33 applied. The applied cooling power [22] is given as follows:
34

$$Q = M*CP*\Delta T/T \quad (2)$$

35
36

37 Where

38 Q = Cooling/Heating Power (kW)
39 M = Mass of cargo (kg)
40 C_p = Specific heat of cargo ($kJ/kg.^{\circ}C$)
41 ΔT = Temperature Difference ($^{\circ}C$)
42 T = Cooling time (Seconds)
43

44 The combined use of auxiliary and cooling power causes an initial power pulse. This pulse is applied till
45 the temperature has reached the set point. After this, the reefer operates in its usual on/off mode. Therefore,
46 in this case, there is an initial power pulse of auxiliary plus cooling power to bring down the temperature.
47

- 48 • *Return air temperature is beyond the lower limit of the allowed bandwidth*

49 In this scenario, there is a high risk of formation of crystal especially in the meat products [24]. Hence,
50 there is an urgency to bring back the temperature to its set point. Hence, heating occurs in reefers till the set
51 point is reached. Like previous scenario, there is an initial power pulse till the set point temperature is
52 reached. Then the reefer operates in its usual on/off mode.
53

- 54 • *Return air temperature is within the allowed the bandwidth*

55 In this case, the return air temperature at the time of plug in is within its allowed bandwidth. Hence, the
56 reefer operates in usual on/off mode. Auxiliary power is used till the temperature has reached the upper
57 limit/lower limit in case temperature rise/fall. After this, cooling/heating power is additional used to bring
58 down(up) the reefer to its set point. The bandwidths of different products groups can be found in [25].
59

60

1 **3.3. Specification of the reefer energy consumption model**

2 After discussing the conceptual model, the data requirements for the simulation model are presented in this
3 section. The main data that is required, is divided into the following categories:

4
5 Data is needed about the arrival and departure schemes of the number of reefers at a terminal. ABB has
6 provides this *reefer data* for a terminal in the Rotterdam port for the period from January 1, 2014 to January 29,
7 2015. This data sheet also includes individual reefer related information such as the type of cargo in the reefer, mass
8 of cargo, the set point temperature and the number of reefer plugs. The energy consumption is modeled for 61,321
9 reefers arriving and departing at the terminal over the same period. These reefers arrive in different periods of the
10 year, have their distinguishable characteristic data and carry various types of cargoes. These cargoes have different
11 weights and have varying amounts of dwell time.

12
13 The *run length of the simulation period* is one year and one month, which is 9,480 hours. The longest
14 cycle time within the simulation model is the reefer with the highest dwell time. This value from data analysis is 12
15 days including the loading/unloading time. A rule of thumb is that the runtime of the model should be at least three
16 times the longest cycle time [26]. This precondition is satisfied in the simulation model, since the run time is 33
17 times the longest cycle time. A time step of 1 minute is used to simulate the temperature increase/decrease function.
18 For peak power calculations, a 15 minute time step is used. No warm-up period is used.

19
20 Important data required is also the *delay time before a reefer is plugged-in* because it affects the
21 temperature fluctuations of the reefers. The delay time depends on whether a reefer is for import or export. For
22 import, the layout of reefers on the ship is an important factor determining their delay time. A quay crane and a
23 stacking crane take 10 minutes to bring the reefer from ship to reefer rack. On average a container ship has 800
24 reefer plugs. Hence, in this case, it takes 2 hours for the last reefer to arrive in a reefer rack. Once a reefer arrives in
25 a rack, a job is sent to a reefer operator at the terminal to plug-it in within one hour. However, in some extreme
26 circumstances, a reefer might be unplugged for more than 6 hours. For an export reefer, the delay time is less due to
27 the arrival of a small quantity of reefers.

28
29 Furthermore, data is needed to determine the temperature increase of reefer in the unplugged and auxiliary
30 power state (see Formula (1)). Based on the literature, the lower the value of *thermal insulation* of a reefer, the
31 better its resistance to temperature increase [27]. This value mainly depends on the age of a reefer. The average
32 lifetime expectancy for a reefer is 12 years [7]. Thus, as the reefer becomes older, its thermal insulation value
33 increases. In the model four thermal values of 0.5, 0.6, 0.7, and 0.8 are divided equally among all the reefers.

34
35 The *electric power of a reefer* consists of auxiliary and cooling power. Based on literature, 2.5 kW of
36 power is required by a reefer to run its basic components such as fans [22]. The cooling power depends on the set
37 point temperature. The cooling capacity slightly varies according to the manufactures and ambient temperature.

38
39 *Electrical contracts* between the utility company and a terminal is confidential information. Hence, general
40 electricity tariffs for industries in The Netherlands are used for calculating energy costs. Within these tariffs, only
41 day, night and peak prices are used. Other costs such as installation costs and maintenance costs are not considered.
42 Thus, the final result will provide additional costs due to peak power demand, day and night time energy costs and
43 total energy costs. In the model, the time step to calculate power peak is 15 minutes. This is usually determined in
44 the contract between the utility company and the terminal operator and varies as per terminal.

45
46 **3.4. Specification of the reefer energy consumption model**

47 Based on the conceptual model, model specifications and the above assumptions, the simulation model is
48 developed (in Simio).

49 When a containership carrying reefers arrives, each reefer is plugged out from its power source. It is then
50 lifted by quay cranes and stacked into the reefer racks. Here, it is again plugged-in a power source. In between this
51 time, the reefer is without power supply. Hence, depending on the conditions, its temperature may rise/fall to
52 varying degrees. Once the reefer is plugged-in, it is operated in its usual on/off mode. Reefers with different set
53 point temperature arrive at the terminal. The above model is replicated for different temperature classes of reefers
54 available from the data sheet. These temperature classes consists of several individual entities. For all these entities,
55 the only common attribute are surface area and their auxiliary power. Rest of the data from the model specification
56 varies for each entity. Hence, every entity (Reefer) is unique in its own way.

57 After assigning these attributes to each of the 61,321 entities, the working algorithm of the reefer is
58 developed. This algorithm is shown in Figure 2. Its working is based on the conceptual model discussed in Section
59 3.2 and is applicable for all the entities.

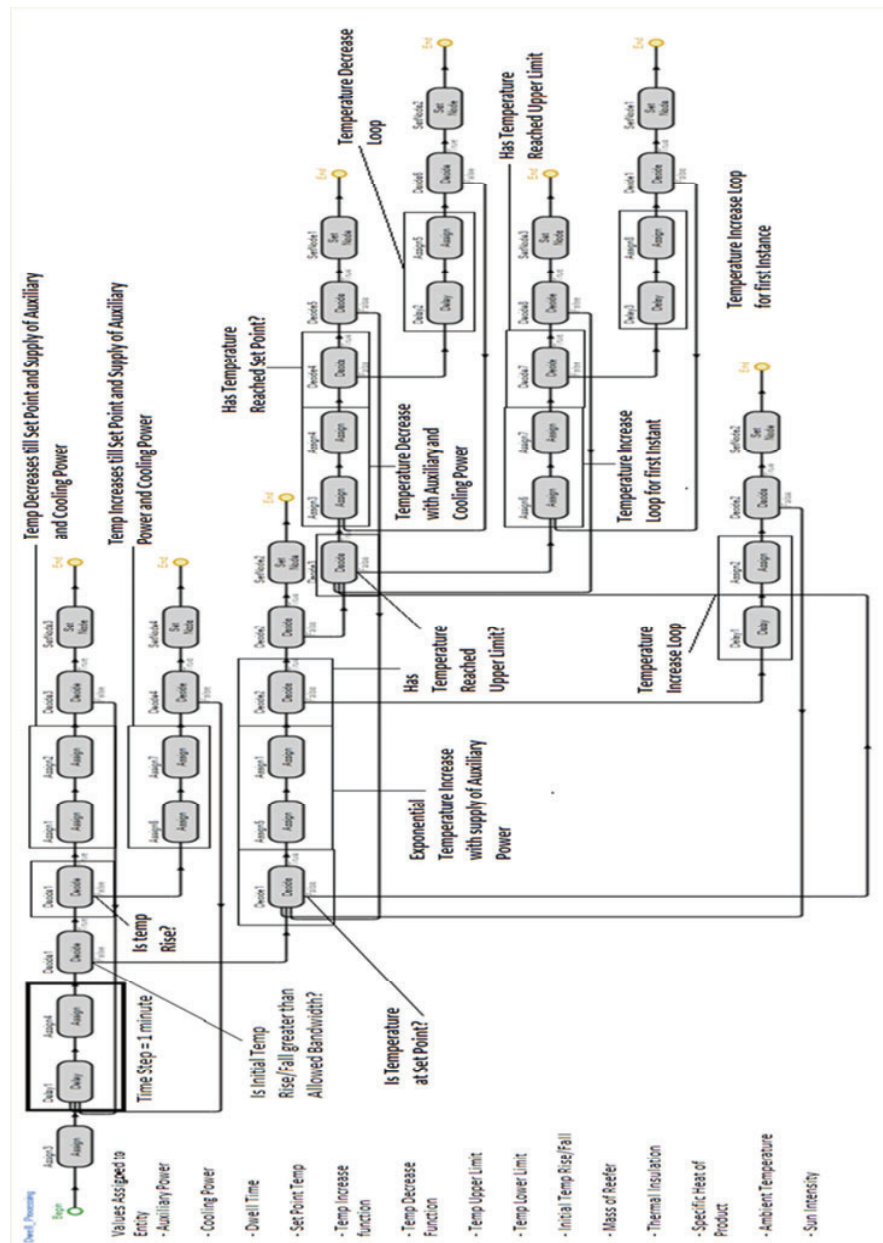

Figure 2 OPERATING ALGORITHM [20]

3.5. Validation of the reefer energy consumption model

Verification and validation are mentioned here briefly. For more details we refer to the thesis of Nafde [20]. Based on the sensitivity analysis [20] the following conclusions can be made:

The mass of the cargo in reefer is the most important factor affecting the temperature fluctuation of a reefer. However, it is difficult for the terminal operator to have control over this factor. The next important variables affecting the reefer temperature are the thermal insulation of a reefer. The temperature of an aged reefer rises more rapidly than compared to new manufactured reefer. Sun intensity also plays an important role in the temperature increase of a reefer. In conclusion, efforts should be made to minimize the impact of sensitive variables on reefer temperature.

Validation of the model is concerned with its accurate representation of the real system. It is mainly concerned with building the right model. A variety of methods are used to validate simulation models. In our research we have applied the following validation methods:

1 *A comparison to a sample working model by Sorensen [7] who is one of the leading researchers in the*
 2 *modeling of refrigeration unit of reefer. A sample working model from his research was compared to our model*
 3 *with a set point of the sample reefer of -20 °C. Temperature fluctuations and cooling power pulses showed identical*
 4 *patterns. Also Face Validation was done with experts in ABB and the Reefer Care Manager at a terminal.*

6 4. MODELING EXPERIMENTS

7 This section shows the results of the Base case (current situation) and the results of two peak shaving
 8 alternatives.

9 4.1 Base case

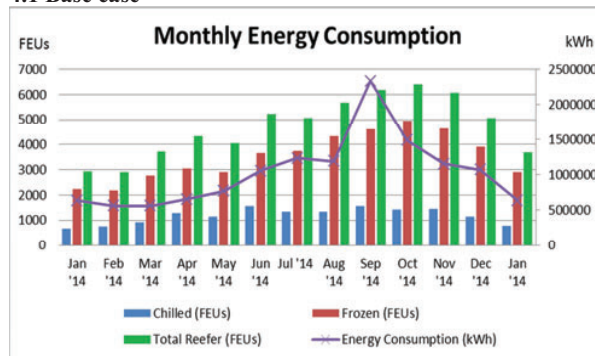

10 **Figure 3A REEFER ARRIVAL AND MONTHLY ENERGY CONSUMPTION – BASE CASE [20]**

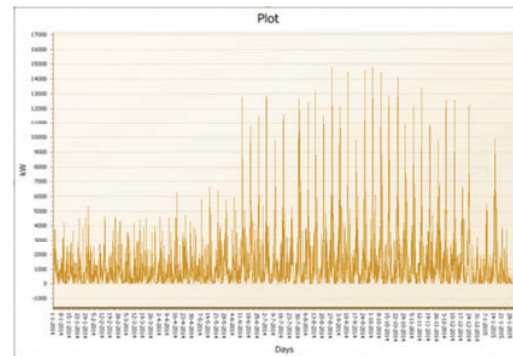

Figure 3B ENERGY CONSUMPTION –BASE CASE [20]

11 The Figures 3A/4B give the number of reefers simultaneously connected to reefer plugs at the terminal for
 12 the entire simulation period (= 9480 hours = 1 year+ 1 month). The throughput of the number of reefers during this
 13 period is 61,321 out of which 45,923 carried frozen products while the rest carried chilled products. In the first
 14 quarter of 2014, the less chilled and frozen reefers arrived at the terminal. This is due to the seasonality of reefer
 15 trade towards Western European Countries. Hence, a small number of reefers is simultaneously connected to reefer
 16 plugs leading to diminutive heights of the spikes.

17 In the month of April, large quantities of chilled products arrive at the terminal. This can be attributed to
 18 the seasonal arrival pattern of deciduous fruits from South Africa. However, the quantity of frozen reefers arriving
 19 in the same period is still small due to the lack of sufficient cargo trade between South America and Western
 20 Europe. Thus, although the arrival of a large number of chilled reefers increases the height of the spike, it is still
 21 small due to the lack of sufficient numbers of frozen reefers.

22 The largest consignment of chilled and frozen products arrive in the period from June to November. For
 23 chilled products, this is due to seasonal export patterns of citrus fruits from South Africa. For frozen products, it is
 24 the seasonality of meat trade between South America and Western Europe. Their combined effect leads to large
 25 number of reefers being simultaneously connected. This causes a large number of very high spikes as shown, i.e. in
 26 a three months period starting in August the limit of 14,000kW is crossed six times (see Figure 3B).

27 4.2 PEAK SHAVING EXPERIMENTS

28 The solutions deal with changes in operational procedures to reduce the peak power demand. Two rules of
 29 operation are tested to analyze their effects on peak demands and the temperature deviations accordingly:

- 30 • *Intermittent distribution of power among the reefer racks*

31 The reefers on terminals are stored in separate reefer racks. Each rack consists of 4 rows and each row further
 32 has multiple slots to store the reefer containers. Each of these slots is provided with an electrical socket for the
 33 operational functioning of reefers. A large number of reefers cooling simultaneously leads to a huge demand of
 34 power from the electrical network. This is the primary reason for the threshold of allowed peak power being
 35 crossed. Thus, if the power supply to these reefer racks is divided into appropriate timeslots, the simultaneously
 36 overlapping of cooling power can be avoided. Therefore, intermittent power supply is suggested for each pair of
 37 container racks with different timeslots of 5 and 15 minutes.

- 38 • *Restriction of peak power consumption among operating reefers*

39 In this case the power supply is restricted to a threshold-value. This has consequences for the individual reefers.
 40 Each reefer will utilize its entire bandwidth of allowed temperature. This implies that after reaching its upper
 41 temperature limit, cooling power is applied until the lower limit of the allowed temperature is reached. As a
 42
 43
 44
 45

1 result, in such a case the cooling power is applied for a longer duration. For a system of reefers operating
 2 simultaneously, this operation affects the probability of overlapping of cooling power. The result is more
 3 impactful for reefers with a narrow bandwidth of allowed temperatures. Thus, by changing the behavior of
 4 power pulses, the simultaneously overlapping of cooling power can be modified.

5
 6 **TABLE 1 SUMMARY OF THE MODELING RESULTS (ANNUAL)**
 7

	Energy Power Consumption			Energy Costs			Quality	
	Peak Power (kW)	Average Power Demand (kW)	Total Energy Demand (kW)	Peak Energy Costs (€)	Total Energy Costs (€)	Total Energy Savings (€)	Impact of Reefer Temperature Difference °C	Product Damage
Base Case	14,831	1,275 +/- 0.17	12.1 Million	250,000 - 300,000	1.09 Million	NA	NA	NA
Intermitted Power Supply 15 minutes Slots	8266 +/- 201.5	544 +/- 0.5	6 Million	0	40,000 - 500,000	600,000 - 700,000	Frozen: Max 0.5 Chilled: Max 0.12 Max -0,18	Extreme ambient T, high risk
Intermitted Power Supply 5 minutes Slots	2,763 +/- 80.3	186 +/- 0.2	2 Million	0	100,000 - 150,000	1 Million	Frozen: Max 0.18	Less product risk
Max threshold 14000KW	13,760 +/- 18.5	1340 +/- 0.3	12.7 Million	0	850,000 - 900,000	200,000 - 250,000	No effect	No risk

8
 9 It has to be noted that reefers are responsible for approximately 45% of the total energy consumption on
 10 terminals [28,29]. Two cases of timeslots are considered. In the first case, the power is supplied in timeslots of 15
 11 minutes. This reduces the peak demand to 8,266 kW. In the second case, the power is supplied in 5 minutes
 12 timeslots. This leads to even further reduction in peak power demand to 2,763 kW. In both cases, the total energy
 13 consumption and thereby the energy cost are also reduced. Thus, this solution results in annual savings of up to €1
 14 Million. However, its downside is that it leads to an increase in the reefer temperature during the power off mode.
 15 This temperature increase is smaller if shorter timeslots are used. Hence, appropriate timeslots can reduce the risk of
 16 product damage in the reefers. However, in order to avoid product damage, proper precautions are required during
 17 implementation of this solution.

18 The third case with a maximum power limit of 14,000 kW reduces the peak power demand to 13,760 kW.
 19 This results in annual savings of more than a quarter Million Euros (based on a peak demand charge per kW (=27
 20 €/kW). Furthermore, it has minimal impact on the temperature inside the reefer. Hence, this solution, though less
 21 impactful, is highly reliable.

22 23 5 CONCLUSIONS

24
 25 This paper describes the development of an energy consumption simulation model to research the
 26 opportunities for container terminals to reduce their peak demands. With this model, two peak-shaving alternatives
 27 could be evaluated with the real reefer data (of 1 year and 1 month) in terms of energy savings, peak savings and the
 28 internal reefer temperatures. In conclusion, despite energy savings with intermittent distribution of power among the
 29 reefer racks, precautions have to be taken against the temperature increase and thereby the quality of products in
 30 reefers. This can lead to additional insurance costs and more importantly affect the reputation of the terminal. In
 31 general, the shorter the division of timeslots, the lower the risk of product damage in reefers. Hence, it is important
 32 to choose an appropriate timeslot to have minimal temperature increases/decreases in reefers and thereby avoiding
 33 damage to products. A more robust solution forms a restriction of the peak power, which leads to smaller energy
 34 savings, but shows no consequences for the internal temperatures.

35 From the sensitivity analysis, it is evident that key variables affecting the temperature changes in reefers
 36 are mass and thermal conductivity. Hence, it is recommended to have regulations to check the cargo mass in reefer
 37 and the quality of reefers operating on terminals. Our next research step is that we will make the reefers more
 38 intelligent (smart) by allowing internal communication between the reefers about their required energy demand.
 39
 40

1 **ACKNOWLEDGEMENT**

2 We thank Tushar Nafde who has worked out our ideas on energy reefer modeling in his master thesis [20].
 3 We also thank ABB, i.e. Patrick Vloemans, who was extremely helpful in providing realistic data of reefer logistics
 4 for a sample terminal.

5
 6 **REFERENCES**

- 7 [1] Rodrigue, J.-P., Notteboom, T., (2014) *Reefers in North American Cold Chain Logistics: Evidence from*
 8 *Western Canadian Supply Chains*, The Van Horne Institute, University of Calgary.
- 9 [2] WORLD SHIPPING COUNCIL (2011). *Container Supply Review*
- 10 [3] Green Cranes, Report on Port Container Terminals Energy Profile, Version 14, 14/02/2013,
 11 GREENCRANES Consortium and TEN: Brussels, 2013
- 12 [4] Wilmsmeier, G., & Zotz, A. K. (2014). Emerging reefer challenges in Latin America. *Environment and*
 13 *Sustainability* 63, 146-150.
- 14 [5] Sargent, R. G., (2013). Verification and validation of simulation models. *Journal of simulation* 7.1: 12-24.
- 15 [6] Zsembinszki, G., Moreno, P., Sole, C., Castell, A., & Cabeza, L. F. (2014). Numerical model evaluation of
 16 a PCM cold storage tank and uncertainty analysis of the parameters. *Applied Thermal Engineering*, 67(1-
 17 2), 16-23.
- 18 [7] Sorensen, K. K. (2013). *Model based control of reefer container systems*. PhD, Aalborg University,
 19 Danmark.
- 20 [8] de Kramer Cuppen, J. E. D. (2015). Quest: 50% power savings for reefer containers. In Wageningen
 21 University (Ed.). Wageningen: Agrotechnology & Food Sciences Group.
- 22 [9] Lukasse, L. J. S., Baerentz, M. B., & Kramer-Cuppen, J. E. D. (2011). Quest II - Reduction of CO2
 23 emissions of reefer containers (pp. 8). Wageningen, The Netherlands: Wageningen University.
- 24 [10] Emerson Climate Technologies. (2014). Reefer Monitoring System. Retrieved July 21, 2015, from
 25 [http://www.emersonclimate.com/en-](http://www.emersonclimate.com/en-us/Products/container_monitoring/Documents/Product_Leaflets/REFCON6_WEB.pdf)
 26 [us/Products/container_monitoring/Documents/Product_Leaflets/REFCON6_WEB.pdf](http://www.emersonclimate.com/en-us/Products/container_monitoring/Documents/Product_Leaflets/REFCON6_WEB.pdf)
- 27 [11] Baldor Electric Company (2005). Energy Management Best Practices. Retrieved July 21, 2015, from
 28 <http://www.sustainableplant.com/assets/WP00010.pdf>.
- 29 [12] James, S.J., James, C., Evans, J.A. (2006). Modelling of Food Transportation Systems- A review.
 30 *International Journal of Refrigeration* 29, 947-957.
- 31 [13] Jedermann, R., Geyer, M., Praeger, U., Lang, W. (2013). Sea transport of bananas in containers - Parameter
 32 identification for a temperature model. *Journal of Food Engineering*, 115(3), 330-338
- 33 [14] Lutjen, M., Dittmer, P., Veigt, M. (2012). Quality driven distribution of intelligent containers in cold chain
 34 logistics networks. *German Academic Society for Production Engineering*, 7(2-3), 291-297.
- 35 [15] Hartmann, S. (2013). Scheduling reefer mechanics at container terminal. *Transportation Research Part E*,
 36 51, 17-27.
- 37 [16] Saanen, Y., Johnson, D., de Waal, A. (2015). How simulation modeling can support environmental
 38 initiatives at container terminals. *Port Technology International*. The Netherlands, TBA: 66-69.
- 39 [17] Abadi, A., Baphana, M., and Ioannou. P. (2009). Simulation Models for Evaluation of Terminal
 40 Operations and Traffic Flow on Adjacent Road Network. Symposium on Transportation Systems. Redondo
 41 Beach, California, IFAC: 129-134.
- 42 [18] Radu, G., & Kruse, B. (2009). Reefer claims loss prevention (pp. 1-3). London: Thomas Miller Insurance
 43 Services.
- 44 [19] Sage, A. P., & Armstrong, J. E. (2000). *Introduction to Systems Engineering [electronic version]*. New
 45 York: John Wiley and Sons Inc.
- 46 [20] Nafde, T., (2015). Smart reefer system Modeling Energy Peaks of Reefers connected at terminals and
 47 suggesting peak shaving solutions to reduce cost. Master thesis, Delft University of Technology, Delft
- 48 [21] Eliasson, S., Margeirsson, B., & Arason, S. (2013, January). Improved reefer container for fresh fish
 49 [electronic version] (pp. 27). Reykjavik. Iceland: University of Iceland.
- 50 [22] Tran, T. K. (2012). *Study of electrical usage and demand at the container terminal*. PhD, Deakin
 51 University, Deakin, Victoria.
- 52 [23] Miller, T. (2012). *Reefer Matters: A focus on some of the issues surrounding the carriage of refrigerated*
 53 *cargoes* (pp. 32). London: UK P&I CLUB.
- 54 [24] Frozen Food Handling and Merchandising Alliance (Producer). (2009). Frozen Food Handling and
 55 Merchandising [electronic article]. Retrieved from [http://www.affi.org/assets/resources/public/frozen-food-](http://www.affi.org/assets/resources/public/frozen-food-handling-and-merchandising-2009-f.pdf)
 56 [handling-and-merchandising-2009-f.pdf](http://www.affi.org/assets/resources/public/frozen-food-handling-and-merchandising-2009-f.pdf)
- 57 [25] Rodrigue, J.P. (2014). Reefers in North American Cold Chain Logistics: Evidence from Western Canadian
 58 Supply Chains. The Van Horne Institute
- 59 [26] Kelton, W. (2000). *Simulation, modeling and analysis*. New York: McGraw-Hill.
- 60 [27] Geysen, D., & Verbeeck, J. (2011). Application of Smart Energy Networks. Retrieved July 21, 2015, from
 61 [http://eharbours.eu/wp-content/uploads/WP-3.5-Application-of-Smart-Energy-Networks-Potential-](http://eharbours.eu/wp-content/uploads/WP-3.5-Application-of-Smart-Energy-Networks-Potential-flexibility-of-reefers.pdf)
 62 [flexibility-of-reefers.pdf](http://eharbours.eu/wp-content/uploads/WP-3.5-Application-of-Smart-Energy-Networks-Potential-flexibility-of-reefers.pdf).

- 1 [28] GreenCranes, (2013). *Green technologies and eco-efficient alternatives for cranes and operations at port*
2 *container terminals*. GreenCranes Consortium and TEN-TEA.
3 [29] van Duin, J.H.R. & Geerlings, H., (2012). Estimating CO₂ footprints of container terminal port-operations.
4 *International Journal of Sustainable Development and Planning*, 6(4), 459–473.
5