

Towards a Resilient Port-Cityscape:

Identifying waterfront transformation potential in industrial inland port cities in transition in the hinterland of Port of Rotterdam

Author: Yaying Hao

Student Number: 5496950

Cluster: Data-Informed Strategies for Sustainable Urban Futures

Mentor: Claudiu Forgaci, Daniele Cannatella

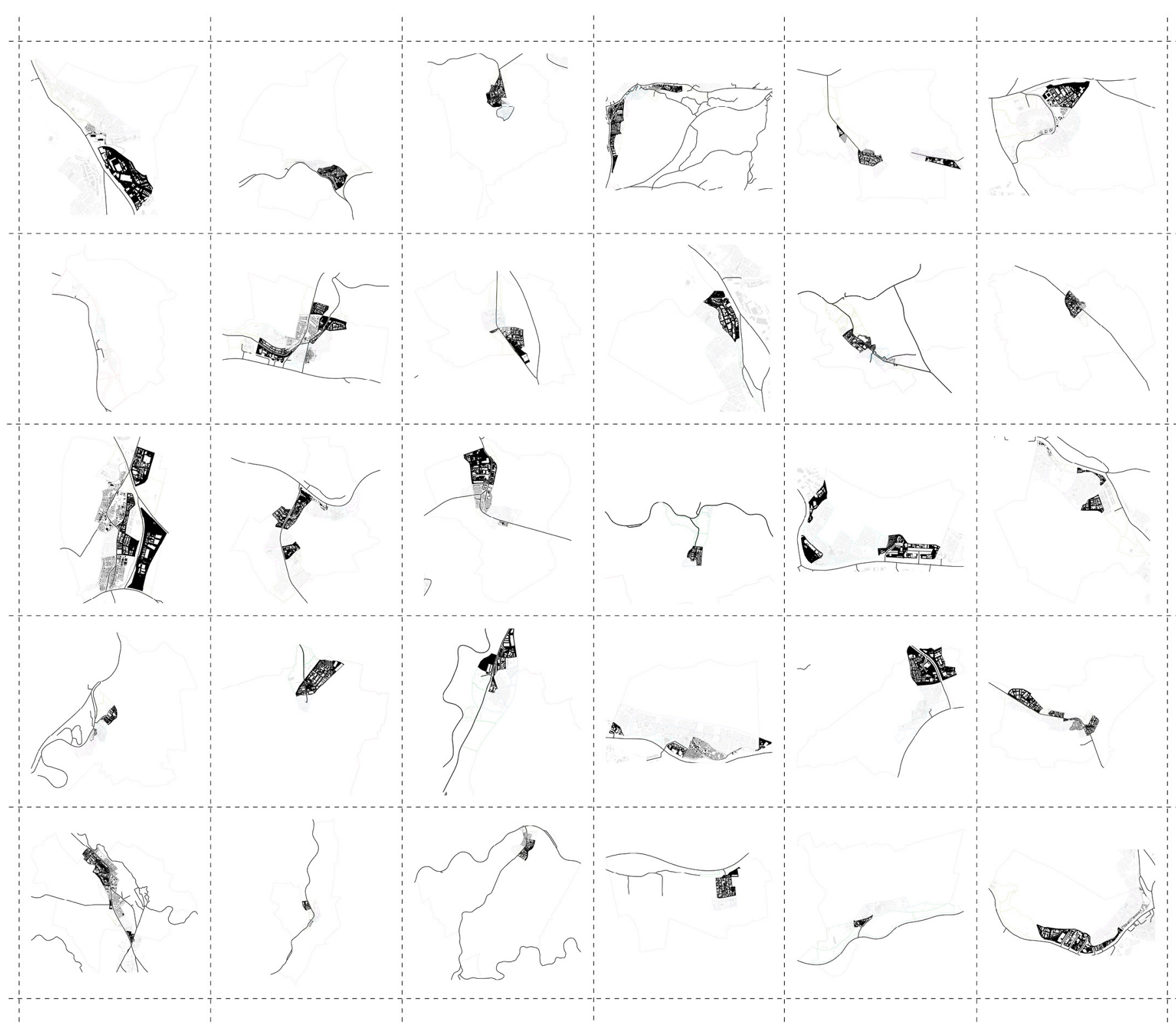

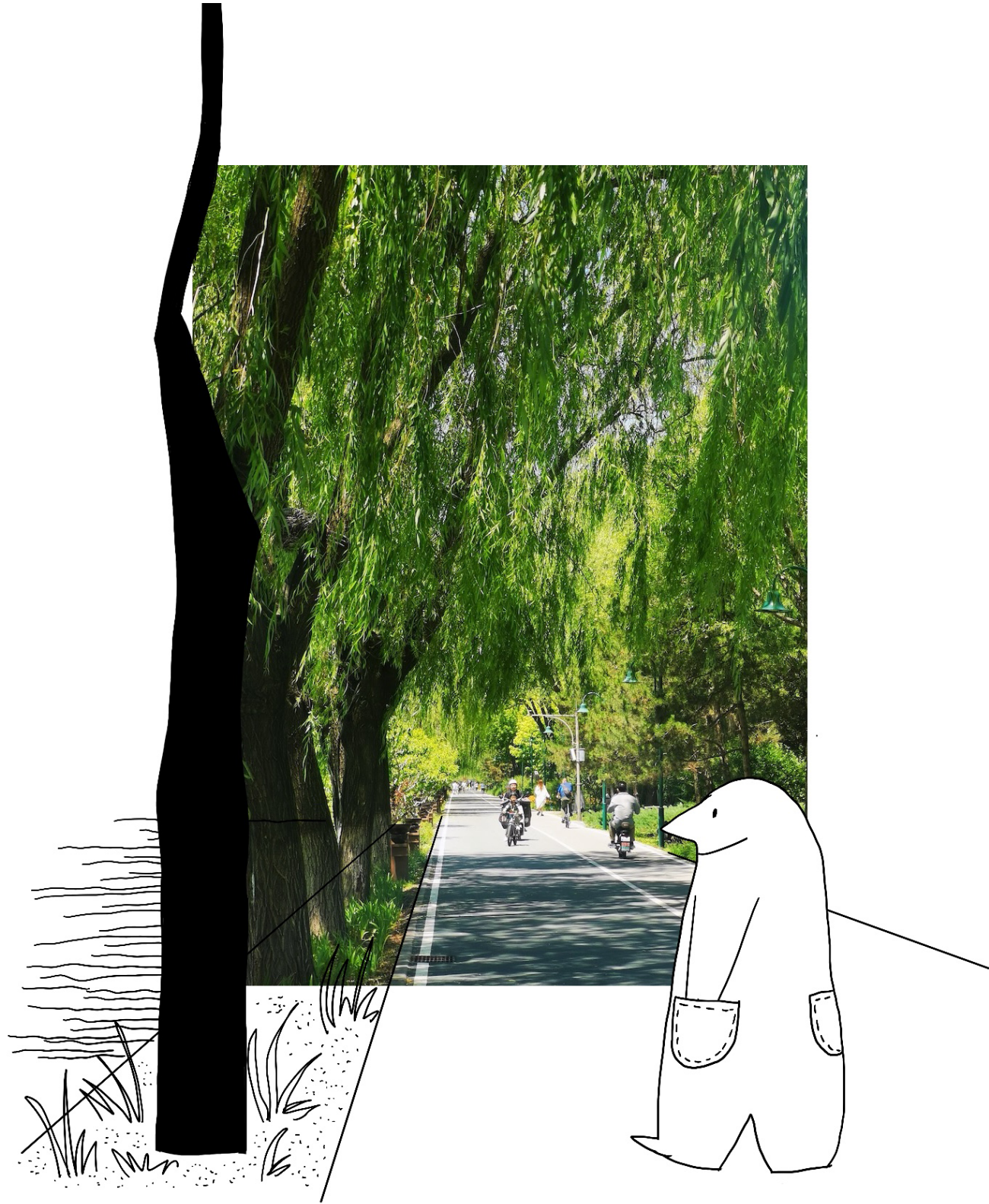



When it's sunny this will be a nice place for a drink.

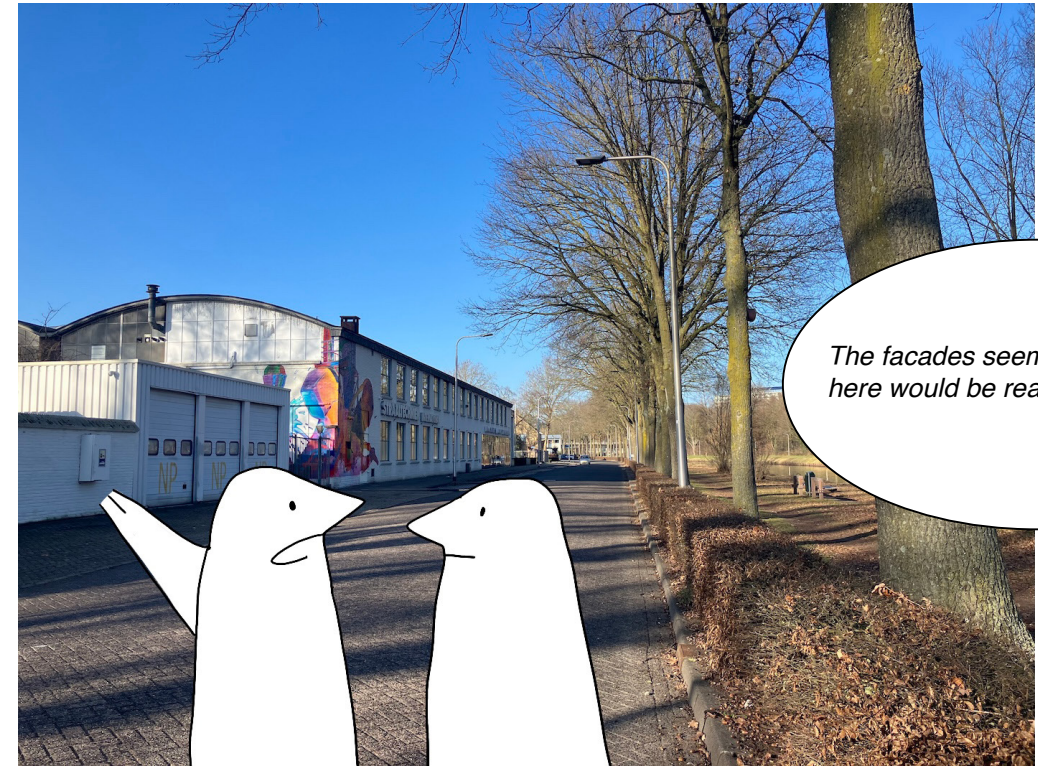

The facades seem dead. A cafe here would be really nice.

This is really a nice pedestrian path along the canal.

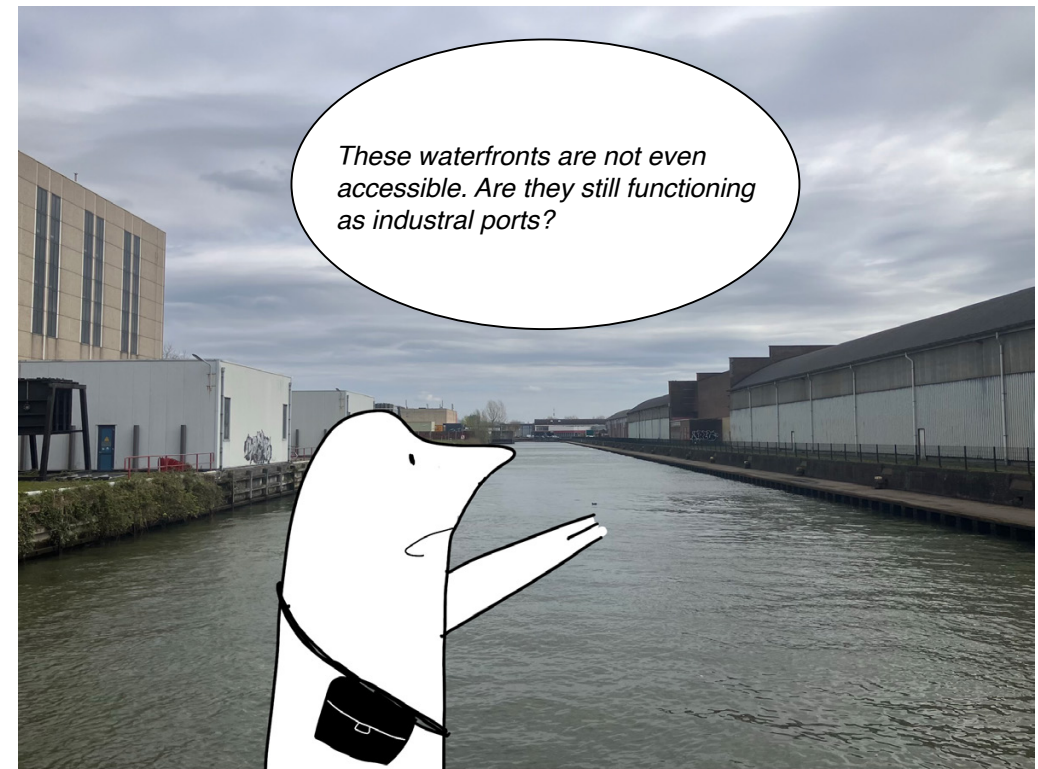

These waterfronts are not even accessible. Are they still functioning as industrial ports?

Rapid Synchronized Expansion of Industry and Housing in IIPCs in the Hinterland of Port of Rotterdam



Source: Topotijdreis

Rapid Synchronized Expansion of Industry and Housing in IIPCs in the Hinterland of Port of Rotterdam

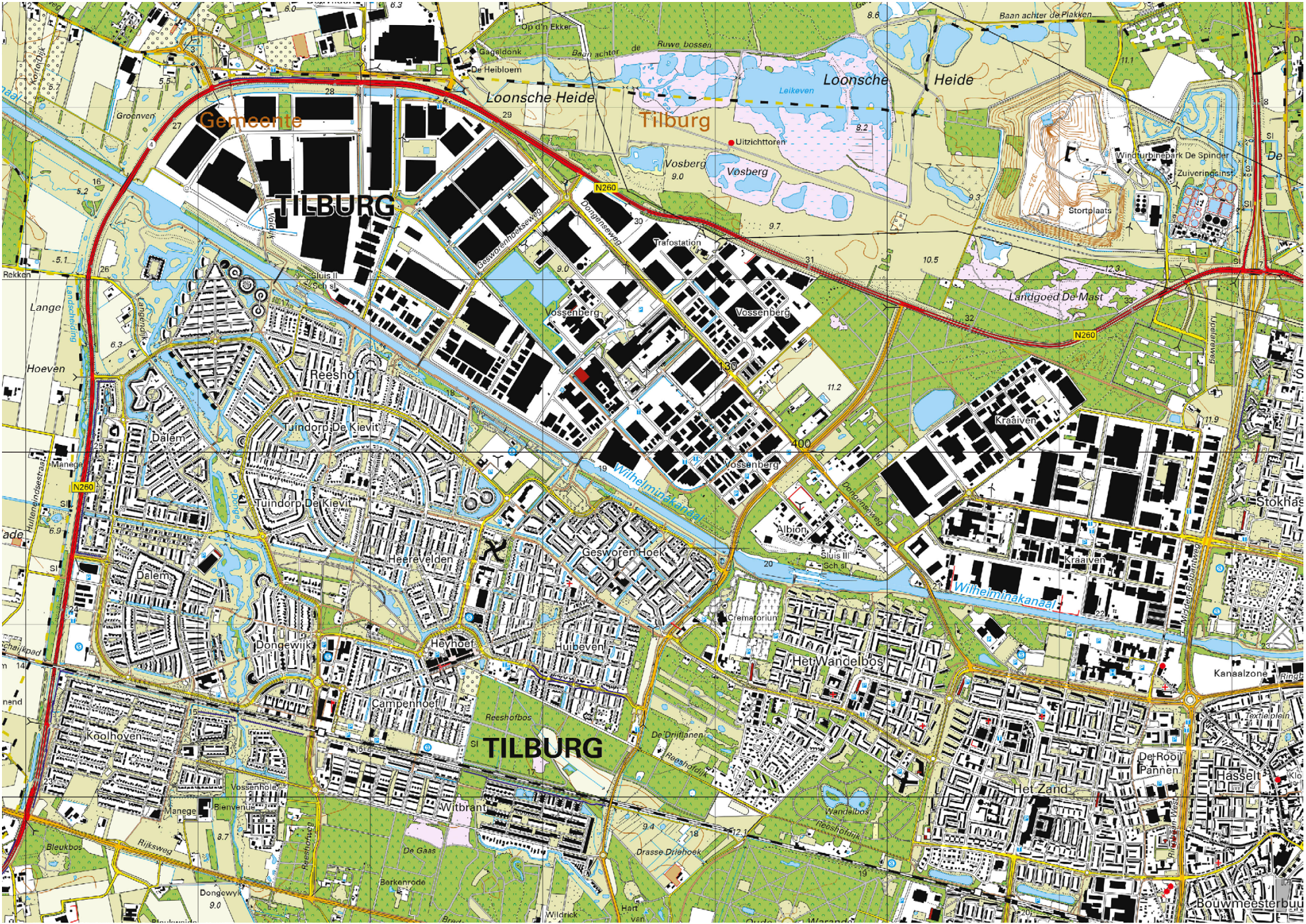

Source: Topotijdreis

Rapid Synchronized Expansion of Industry and Housing in IIPCs in the Hinterland of Port of Rotterdam



Source: Topotijdreis

Rapid Synchronized Expansion of Industry and Housing in IIPCs in the Hinterland of Port of Rotterdam

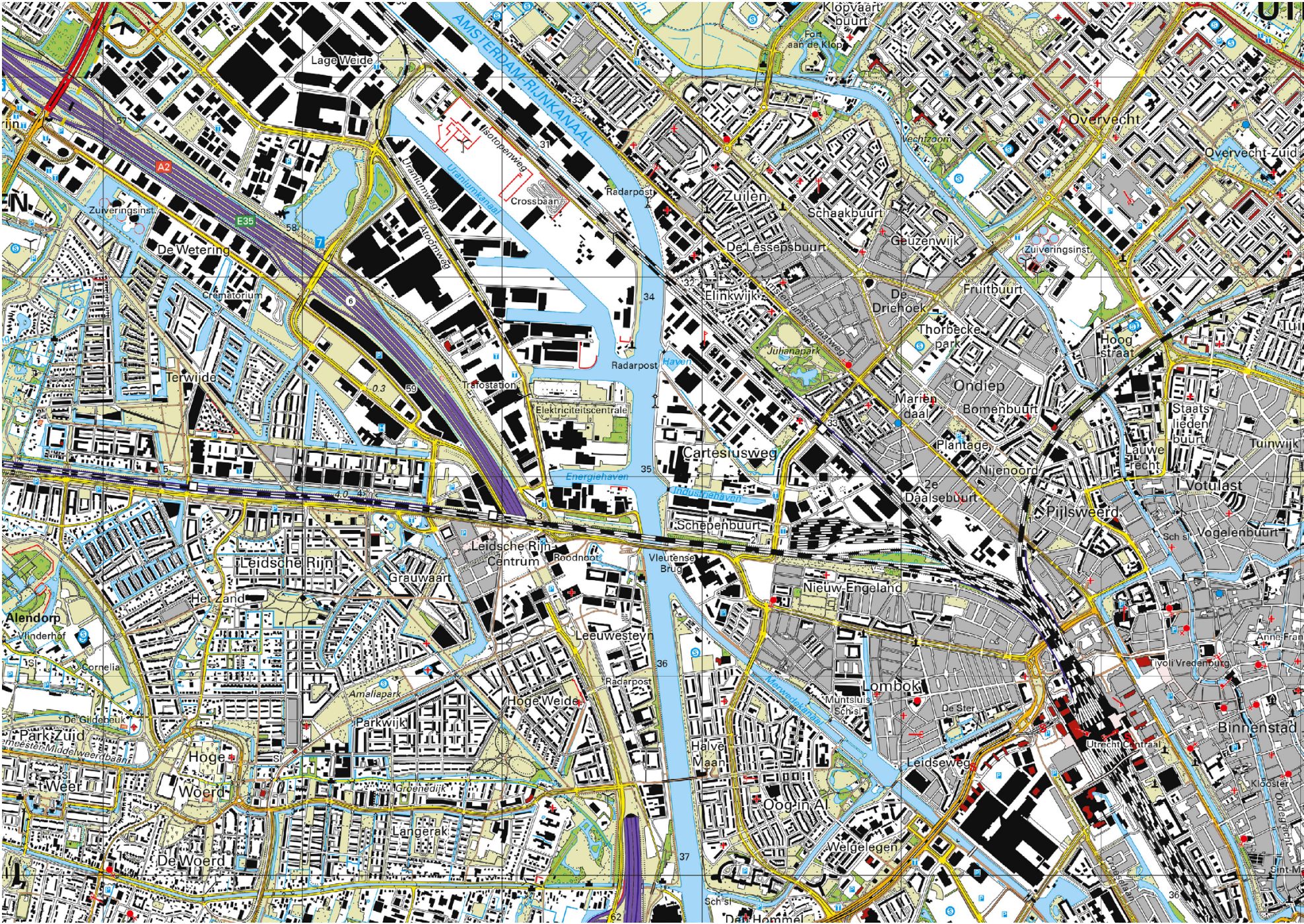

Source: Topotijdreis

Rapid Synchronized Expansion of Industry and Housing in IIPCs in the Hinterland of Port of Rotterdam



Source: Topotijdreis

Rapid Synchronized Expansion of Industry and Housing in IIPCs in the Hinterland of Port of Rotterdam

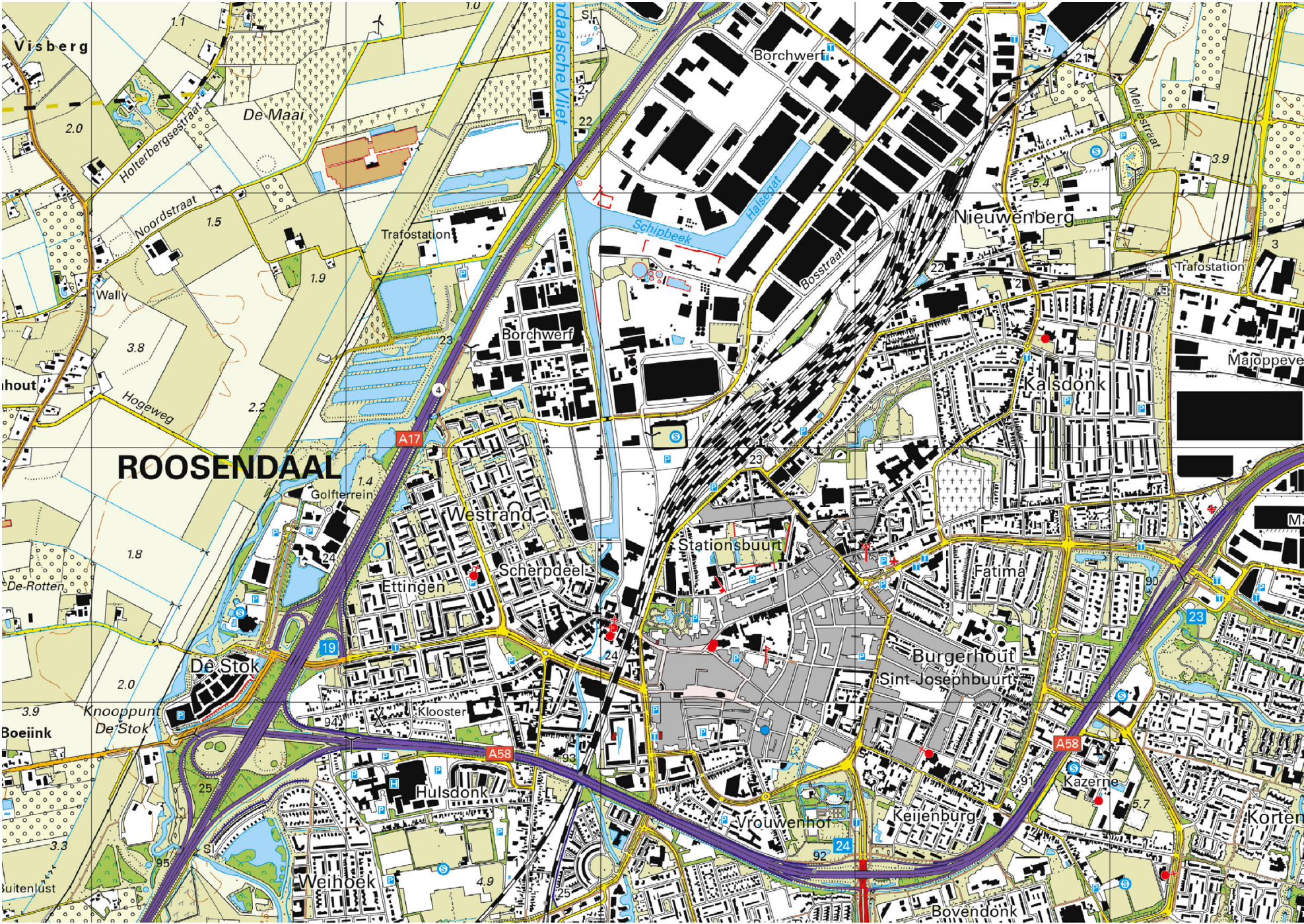

Source: Topotijdreis

What is the question that this thesis aims to address?

*How can **waterfront transformation potential** in industrial inland port cities be identified through a **multi-scalar framework** to cultivate a more **adaptive and resilient port-cityscape**?*

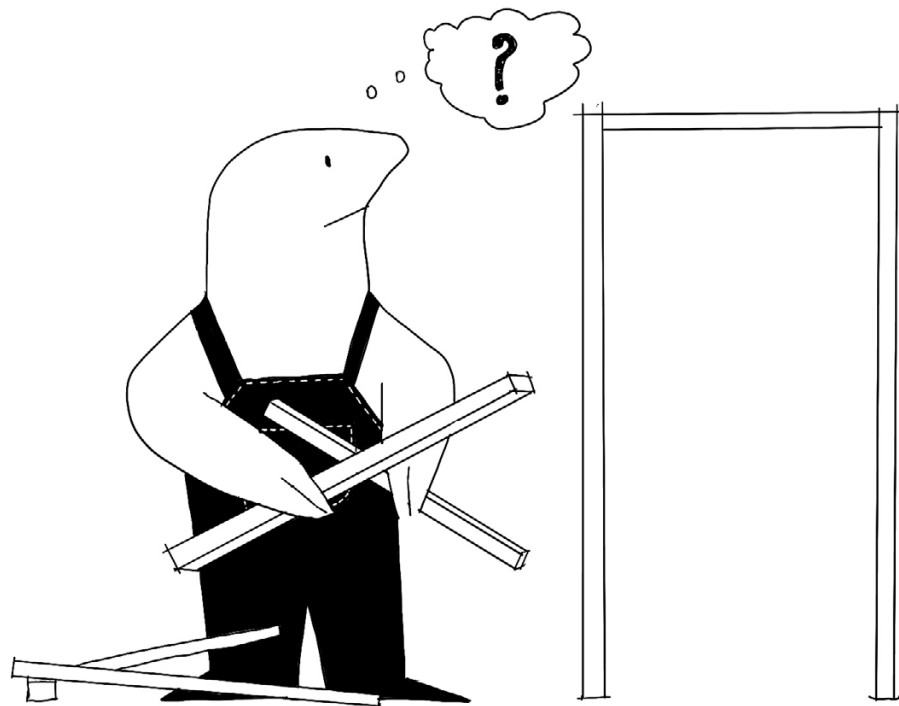

**Macro Level
Social-Economic Perspective:**

Transformation Potential Identified from IIPC Development Model



Should we transform here?

**Micro Level
Urban Morphological Perspective:**

Transformation Potential Identified from Urban Morphological Imbalances



What must we fix here?

Transformation Potential Identified from IIPC Development Model

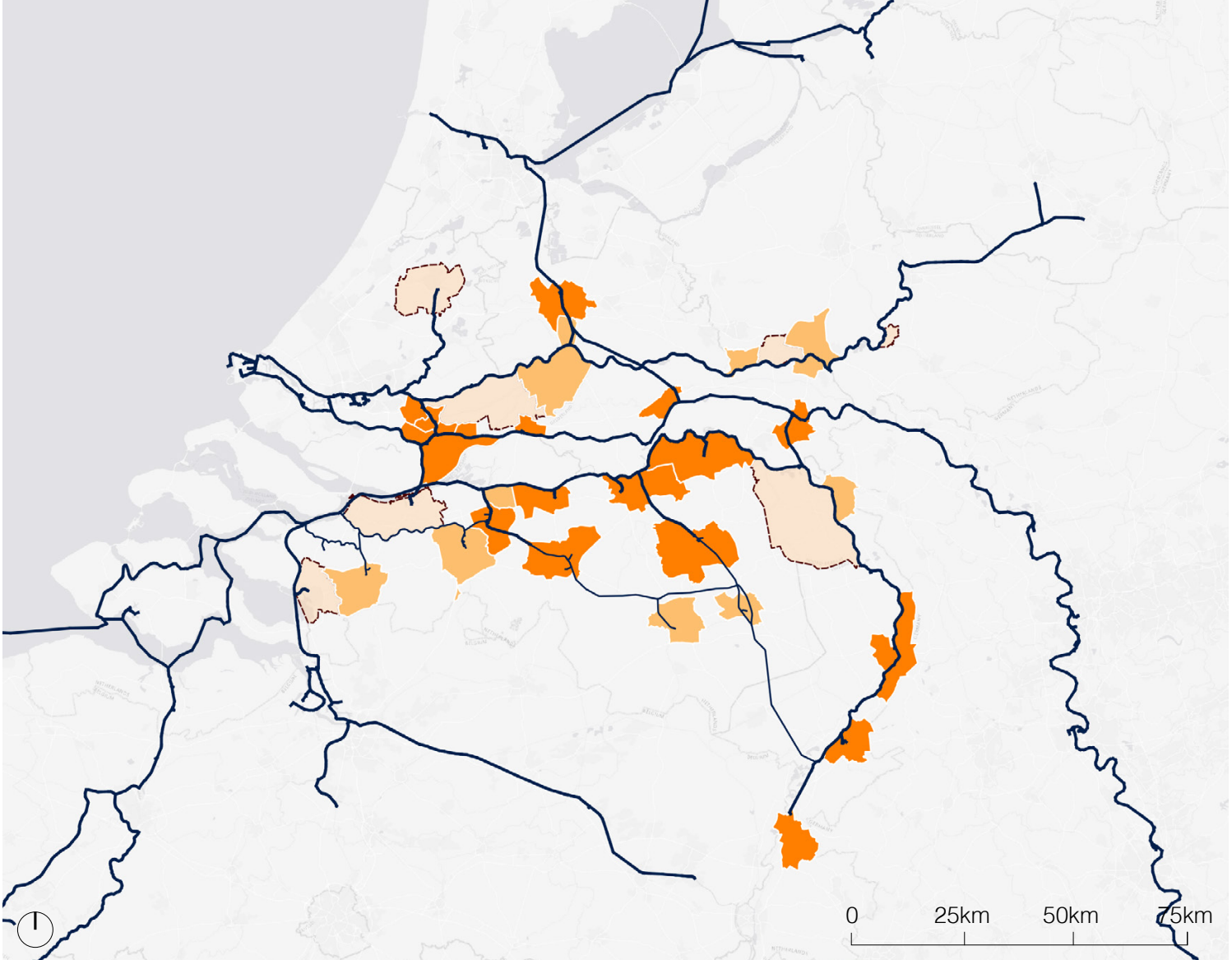

Legend

- selected IIPCs with direct barge route connection with Port of Rotterdam
- IIPCs selected with other inclusion rules

Source: Port of Rotterdam Authority

- IIPCs excluded based on exclusion rules
- barge route connection with Port of Rotterdam
- secondary transportation waterway

Transformation Potential Identified from IIPC Development Model

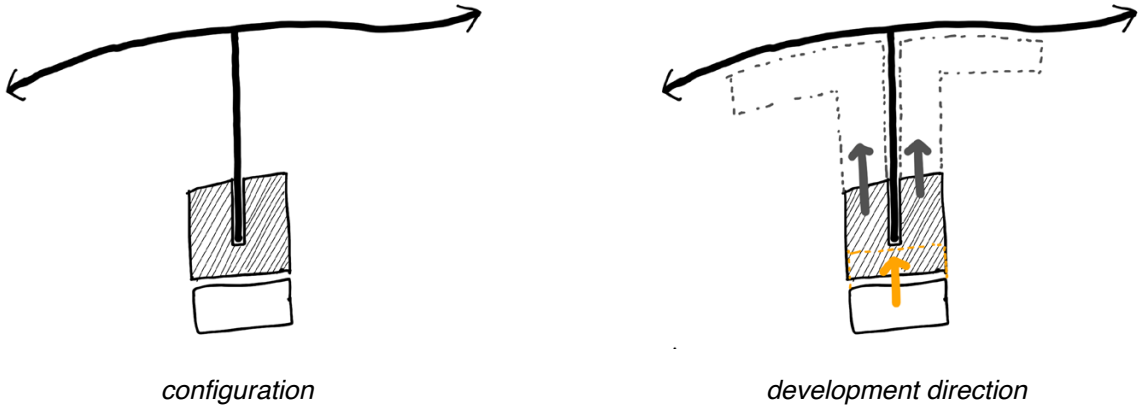

Pattern: Next-to

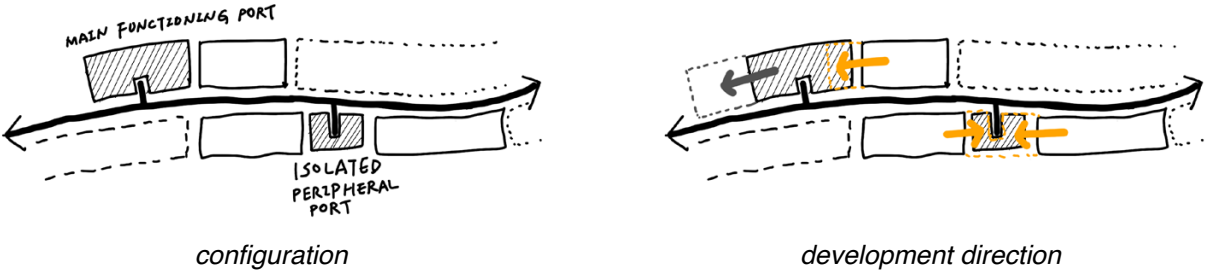
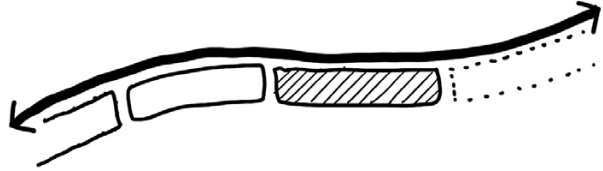

Pattern: In-between

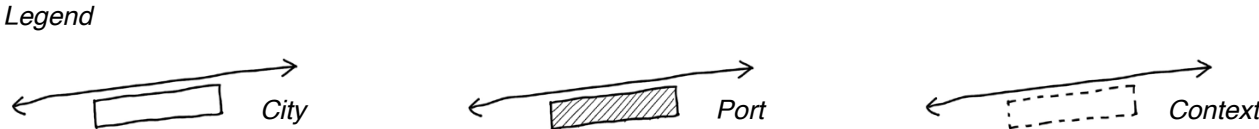
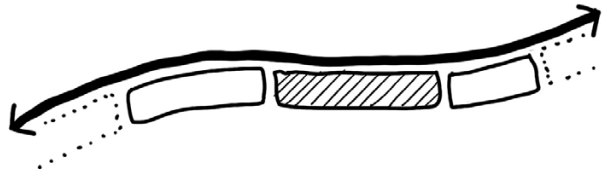

Pattern: Blocking



Transformation Potential Identified from IIPC Development Model

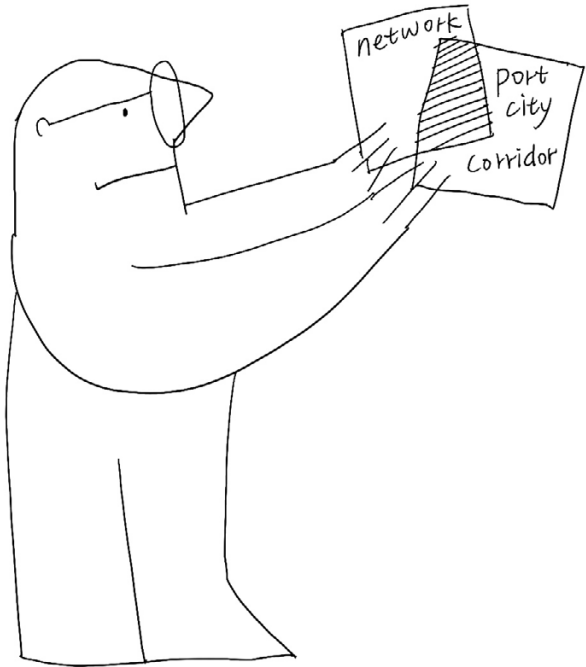

Extension

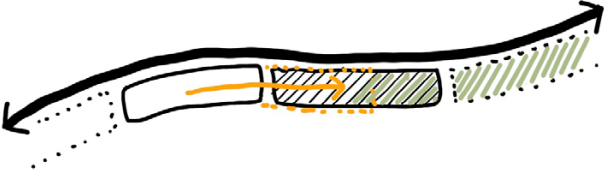

Corridor

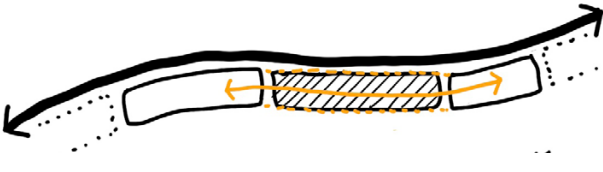

Penetration

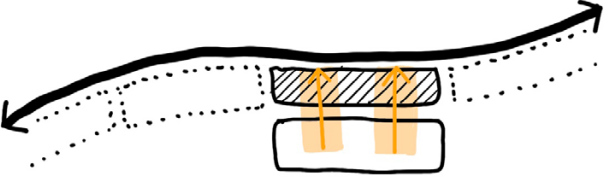

Buffer Zone

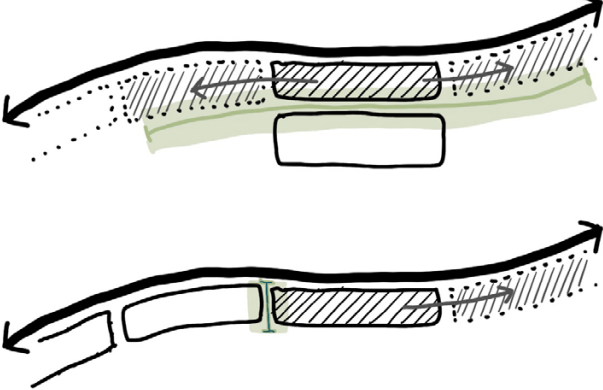

Transformation Potential Identified from Urban Morphological Imbalances

Optimization Gap

One Step away from a Nice Piece of Waterfront



The facades seem dead. A cafe here would be really nice.

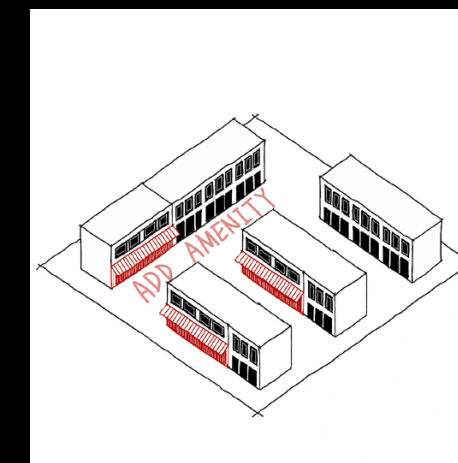
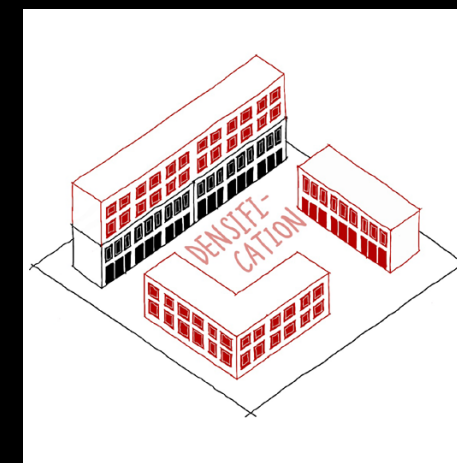
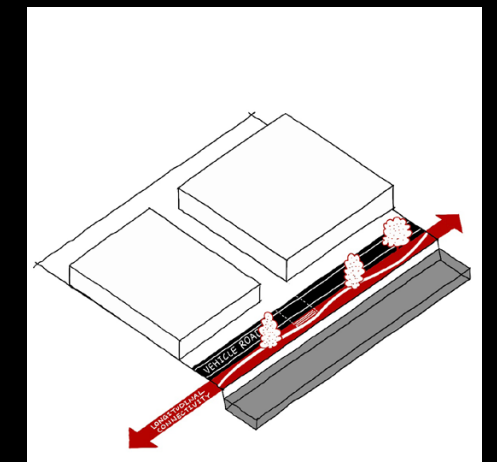
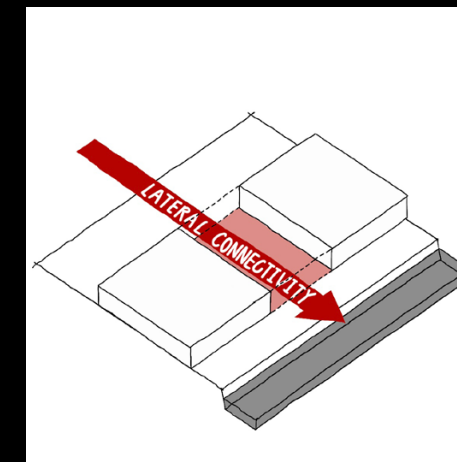
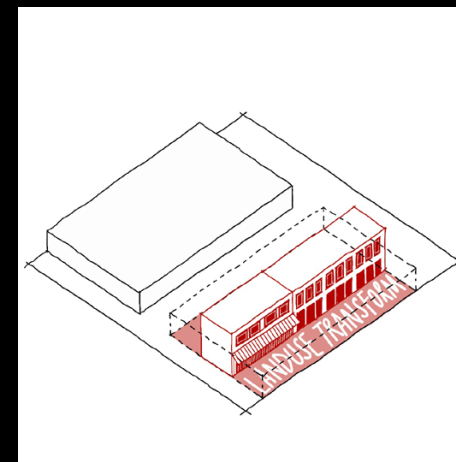

Transformation Potential Identified from Urban Morphological Imbalances

Environmental Quality Deficit

Urgency to Improve Living Experience in Residential Area

It's amazing that someone actually lives here. Everthing seems to be built for cars and trucks here.

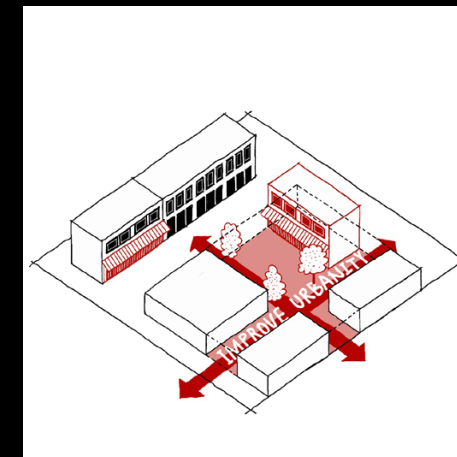

Transformation Potential Identified from Urban Morphological Imbalances



Urgency and Low-hanging Fruit



Starting Point for Waterfront Transformation



Triggering Future Development

.....

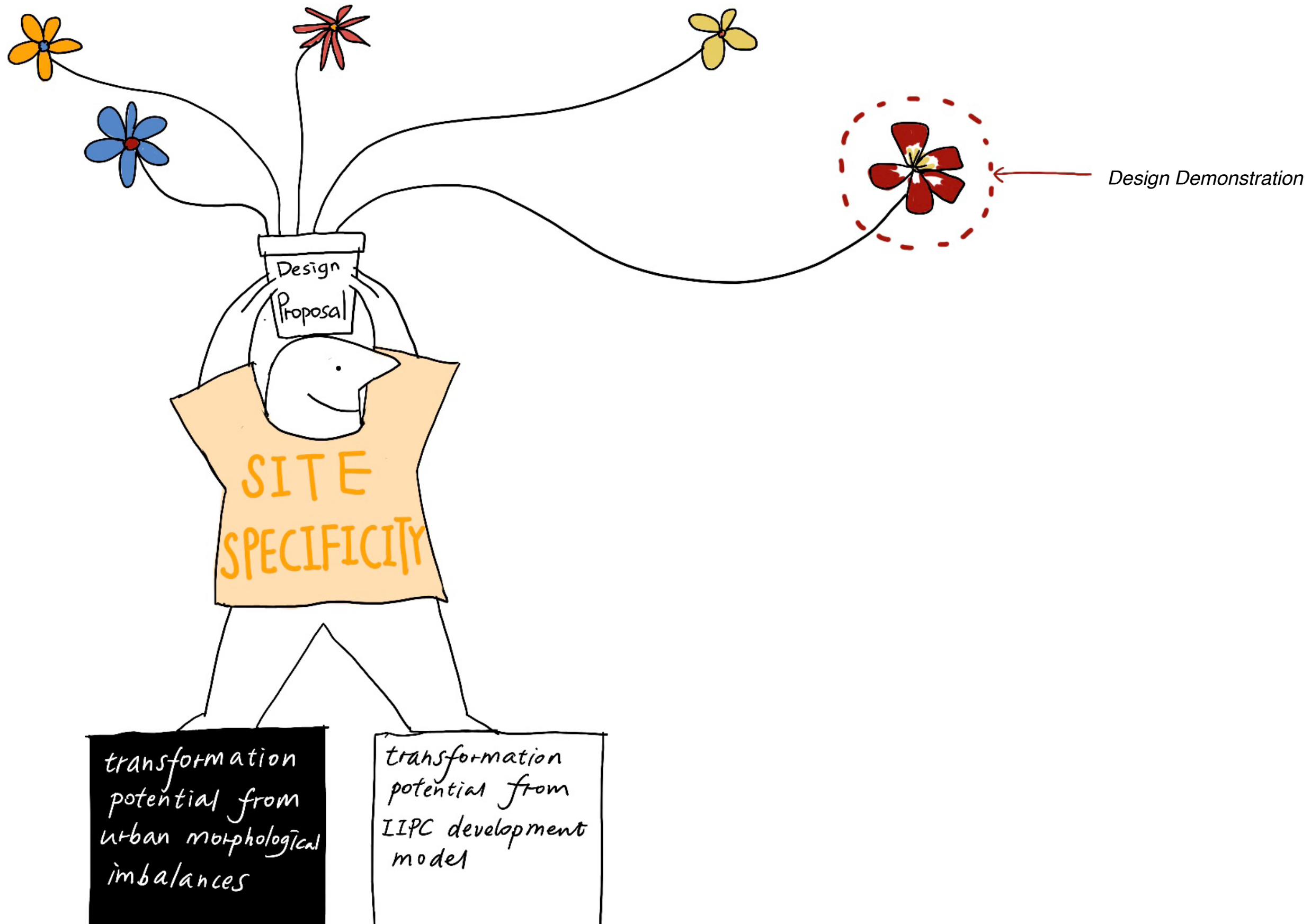

Macro Level Social-Economic Perspective:

Transformation Potential Identified from IIPC Development Model



*In-between pattern
Isolated port in consolidation city*

Micro Level Urban Morphological Perspective:

Transformation Potential Identified from Urban Morphological Imbalances

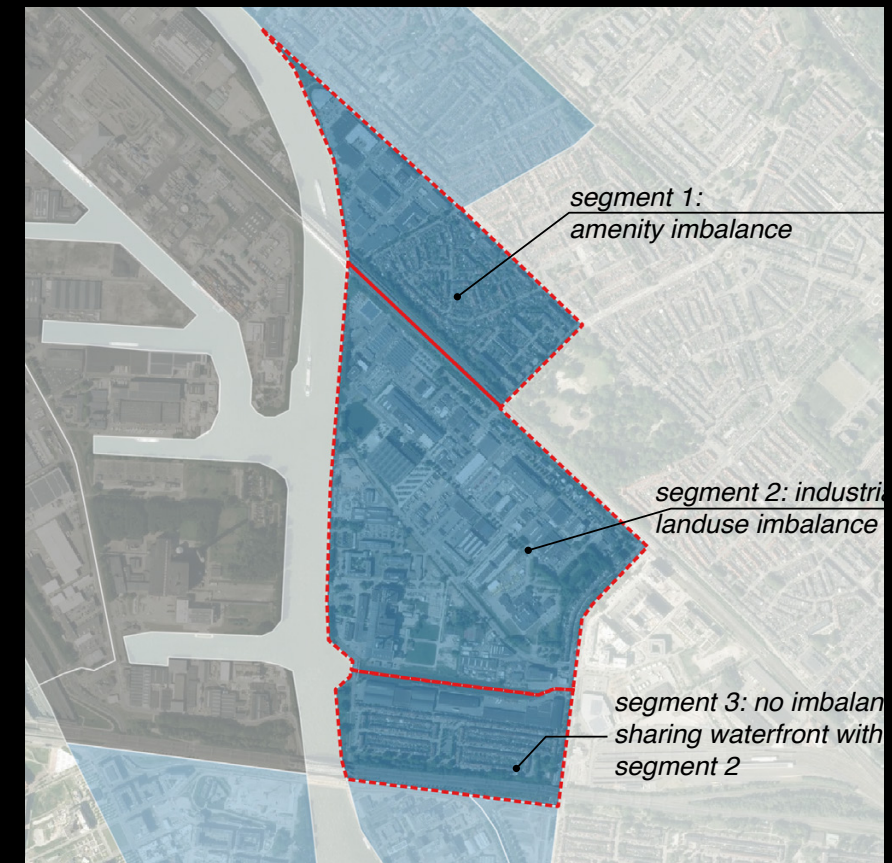

*Identified urban morphological
imbalances*

Macro Level Social-Economic Perspective:

Transformation Potential Identified from IIPC Development Model

connectivity strategy: corridor

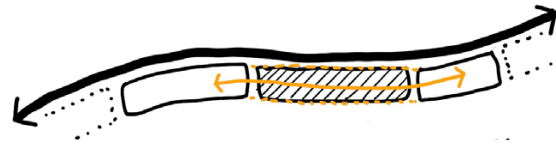

intensity strategy: co-existence



Micro Level Urban Morphological Perspective:

Transformation Potential Identified from Urban Morphological Imbalances

*intensity strategy:
add amenity*

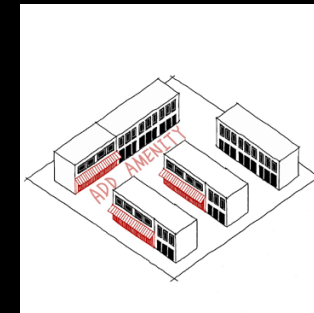

*intensity strategy:
landuse transformation*

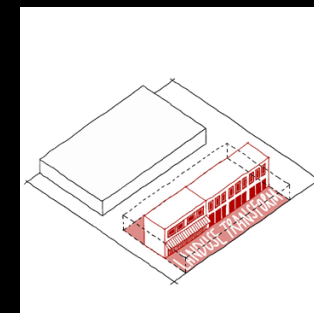

Site Specificity: Where to Locate the Strategies?

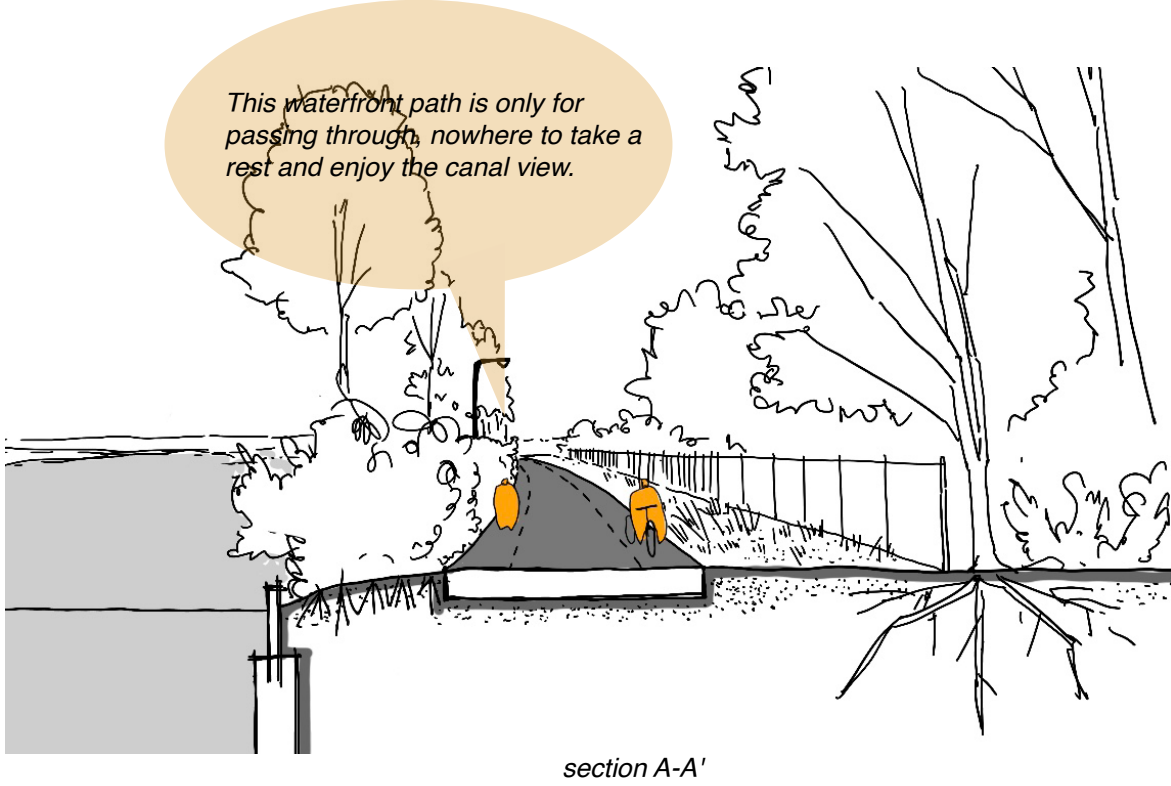
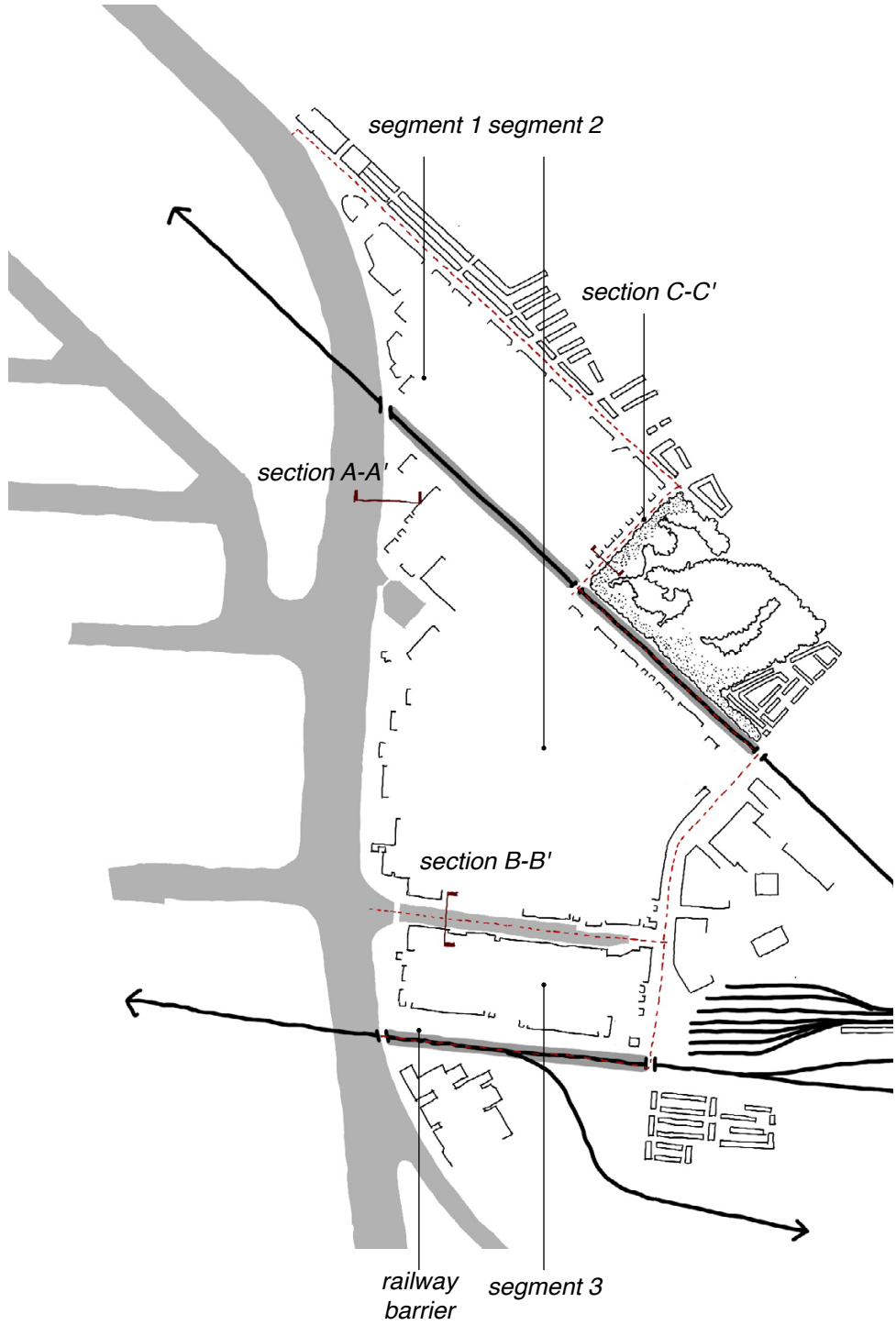

Site Specificity: Where to Locate the Strategies?

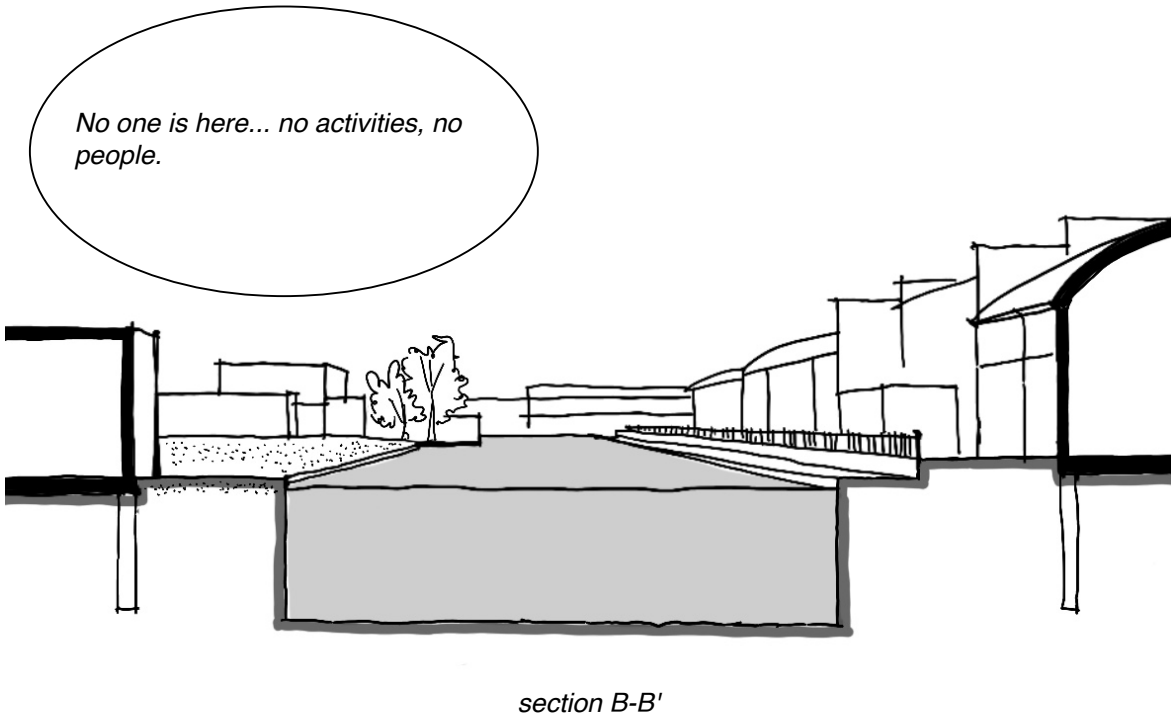
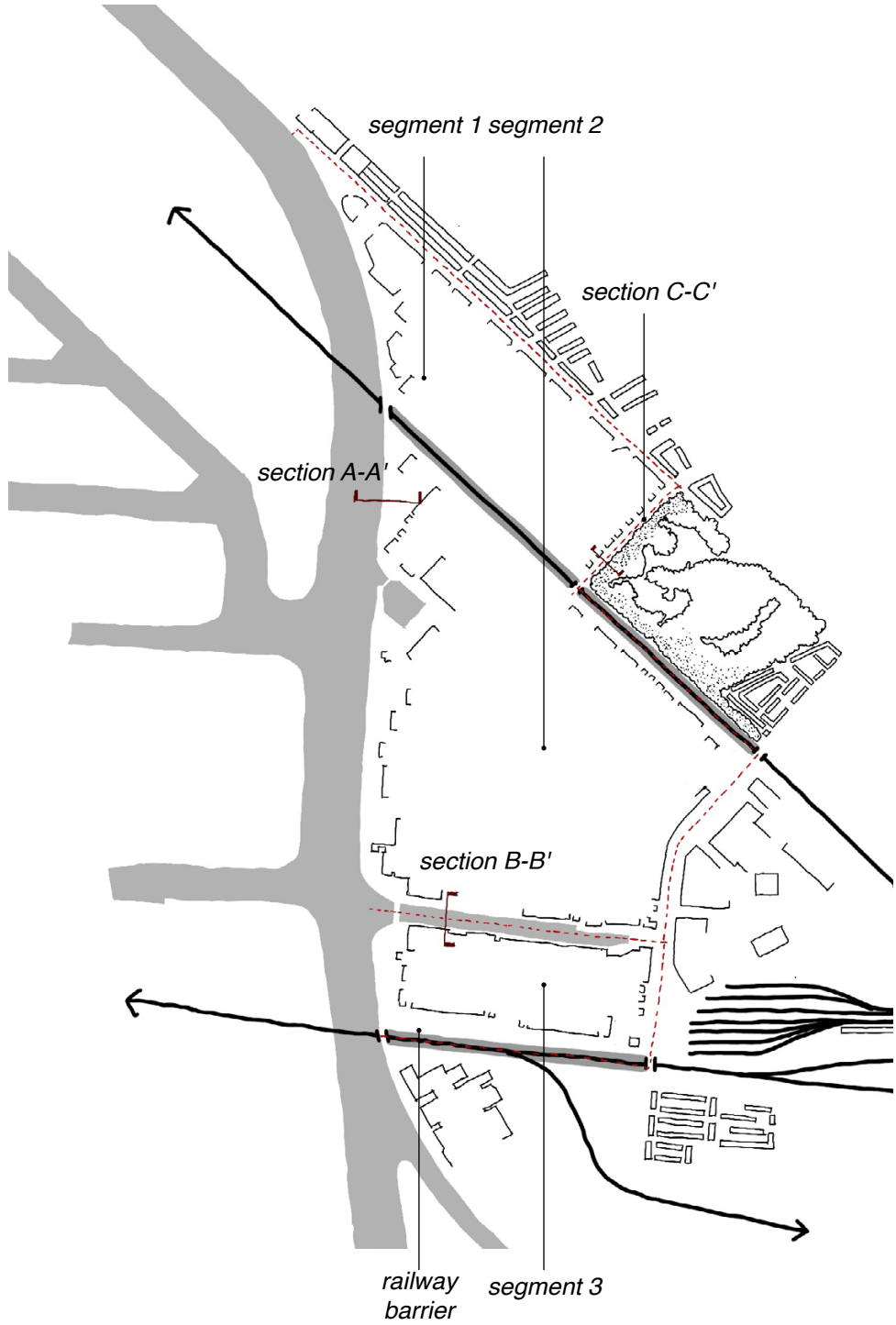

section B-B'

Site Specificity: Where to Locate the Strategies?

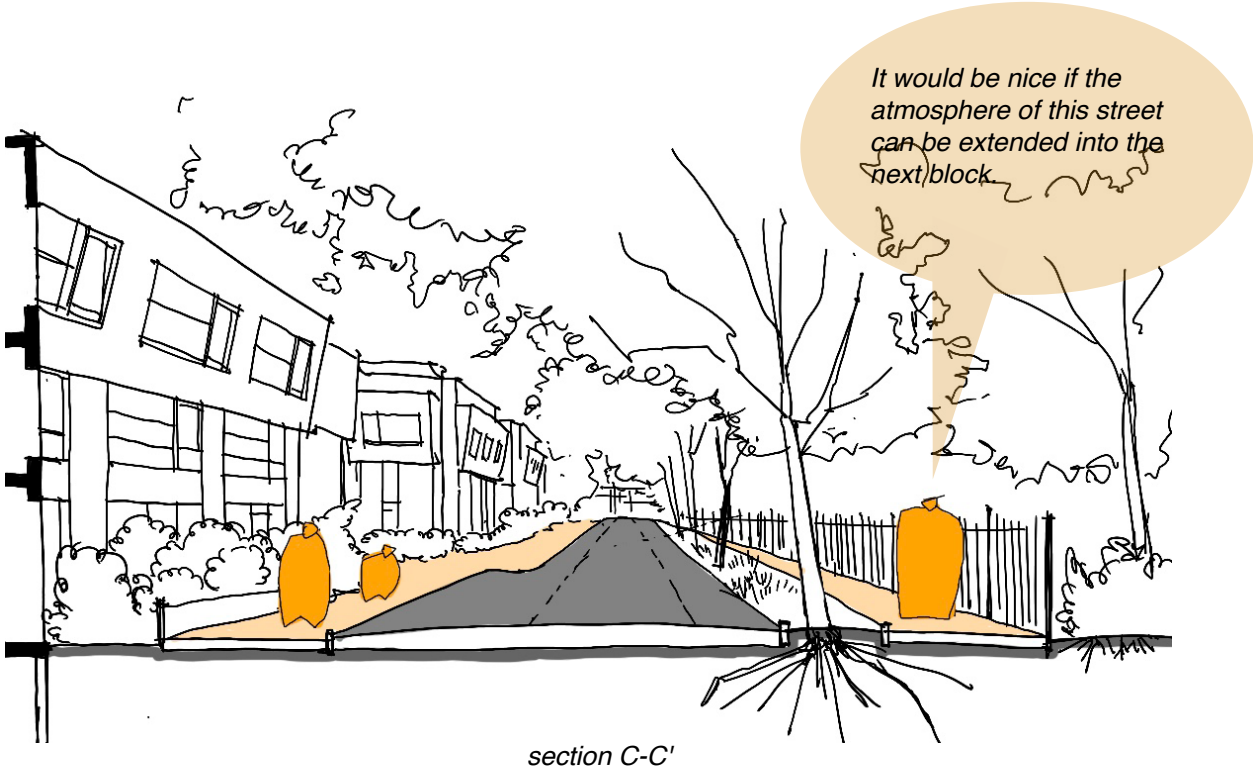
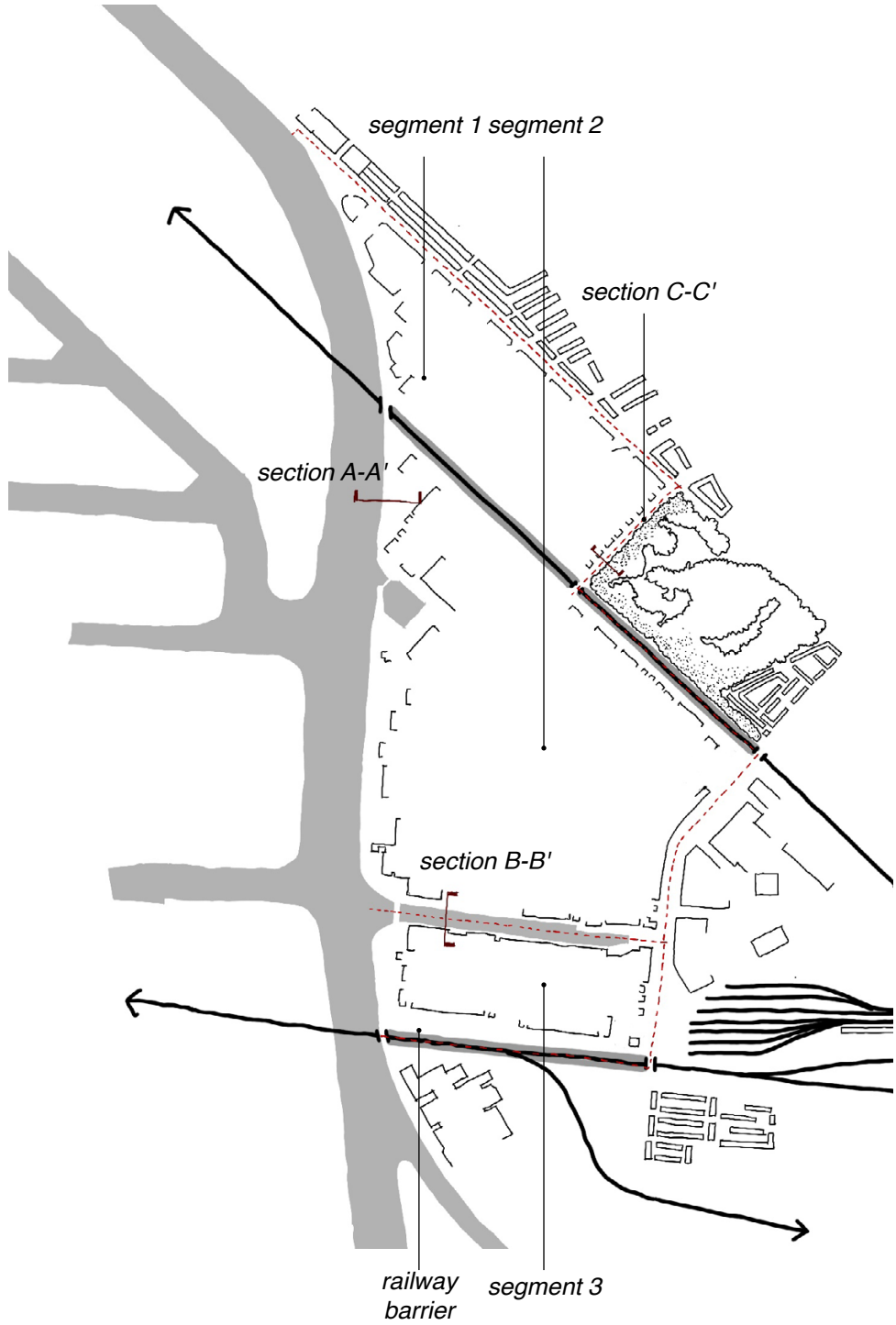

Connectivity and Intensity: Applying the Design Strategies

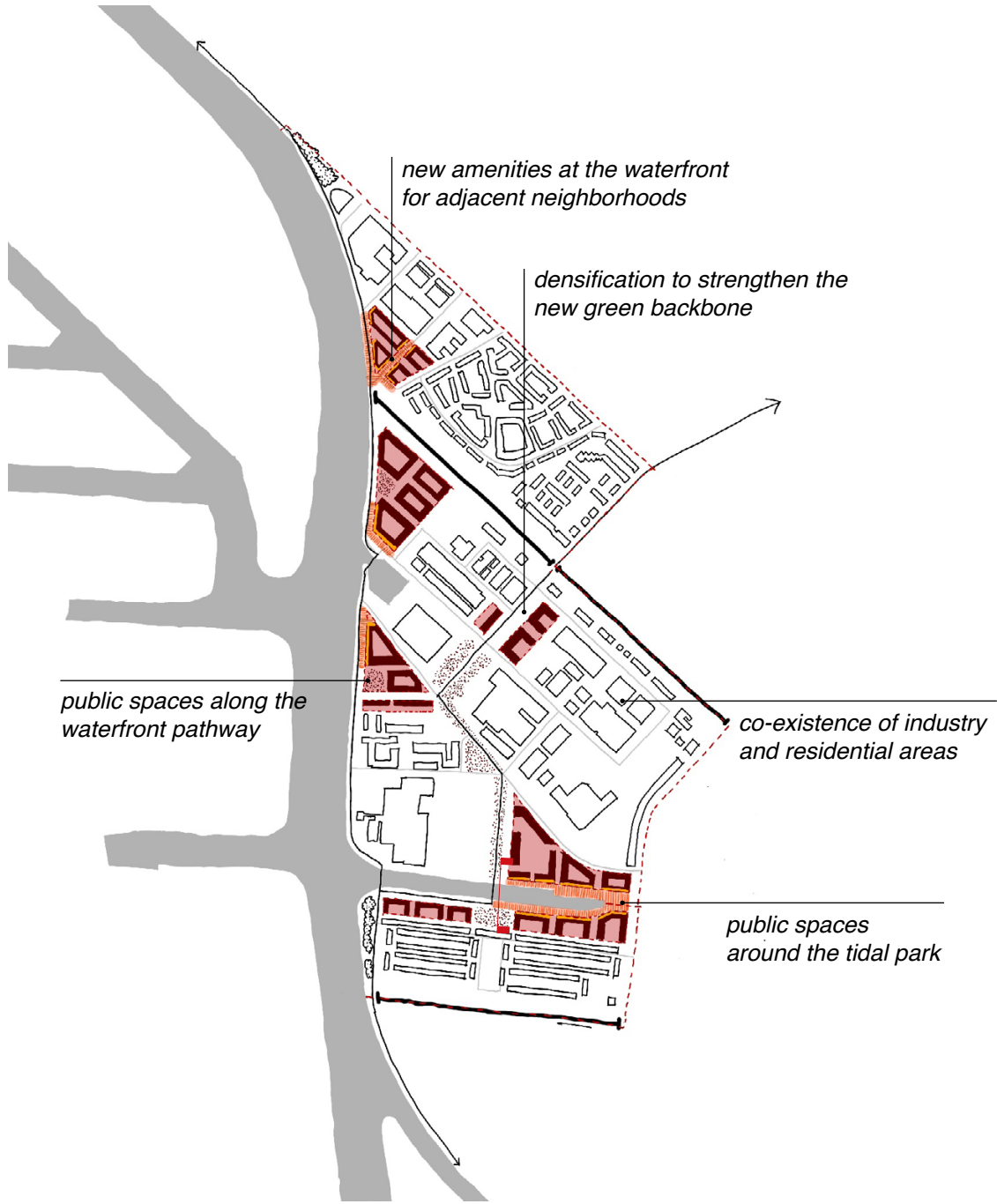
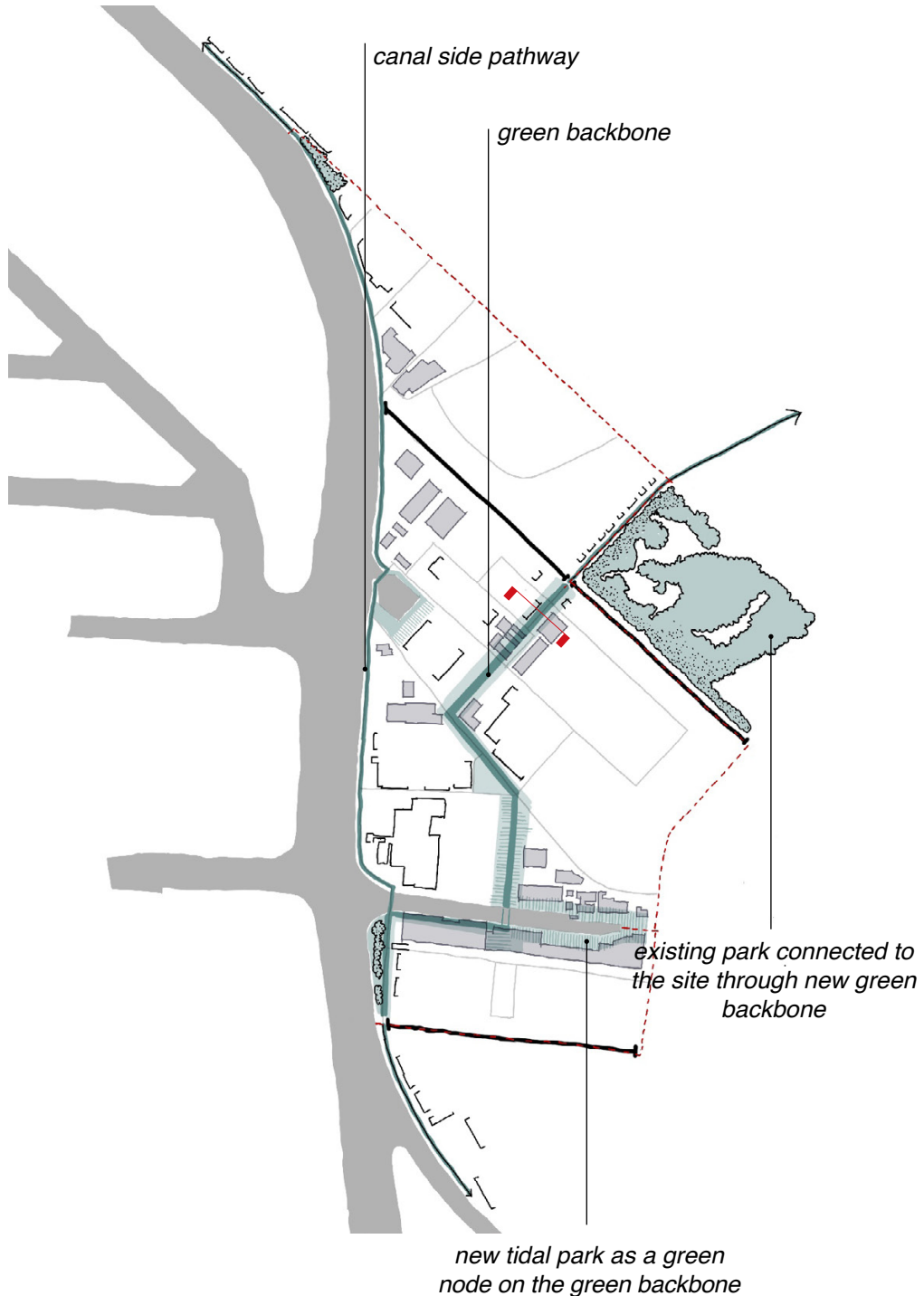

Green Corridor: Before and After

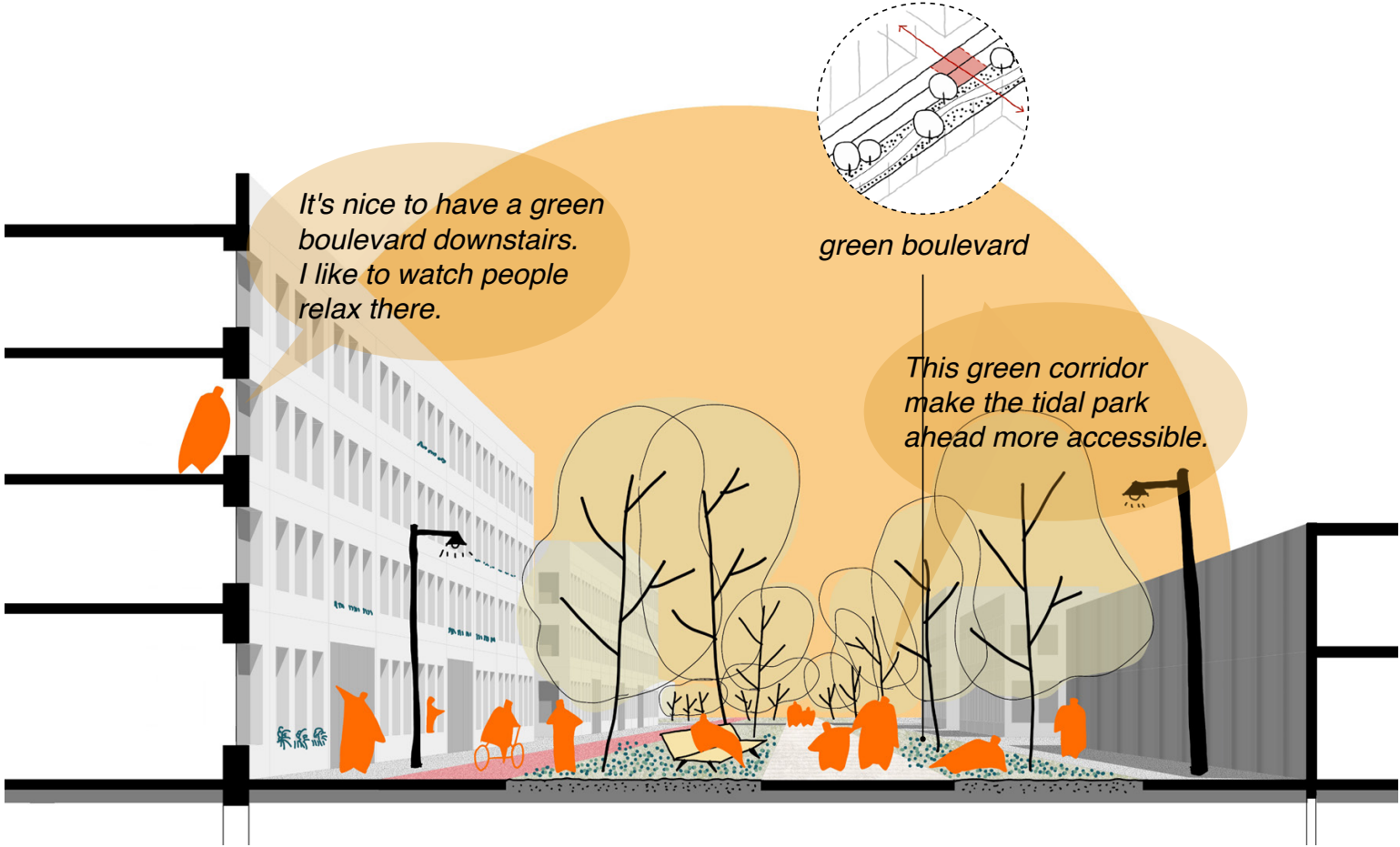
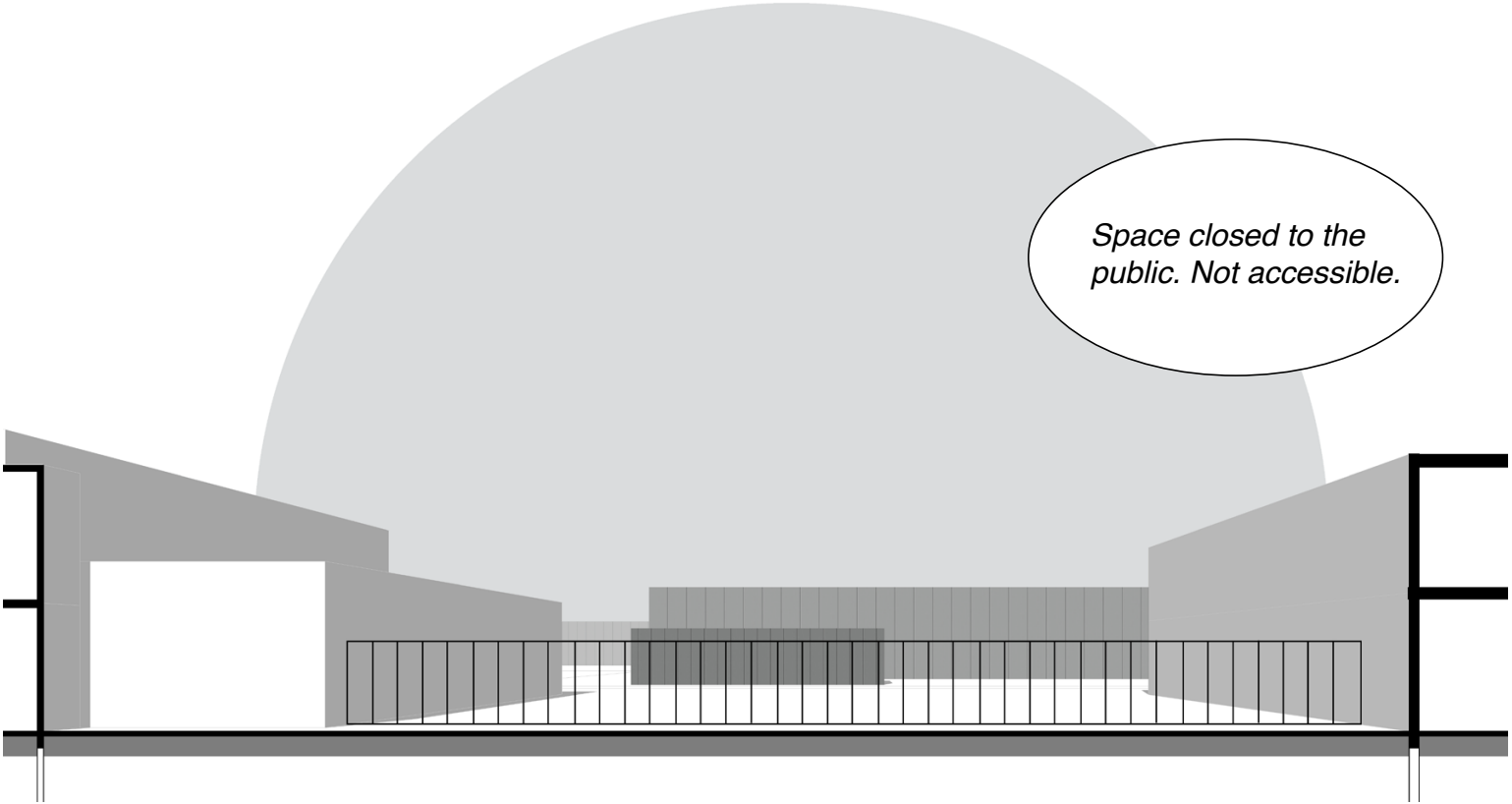

Urban Waterfront: Before and After

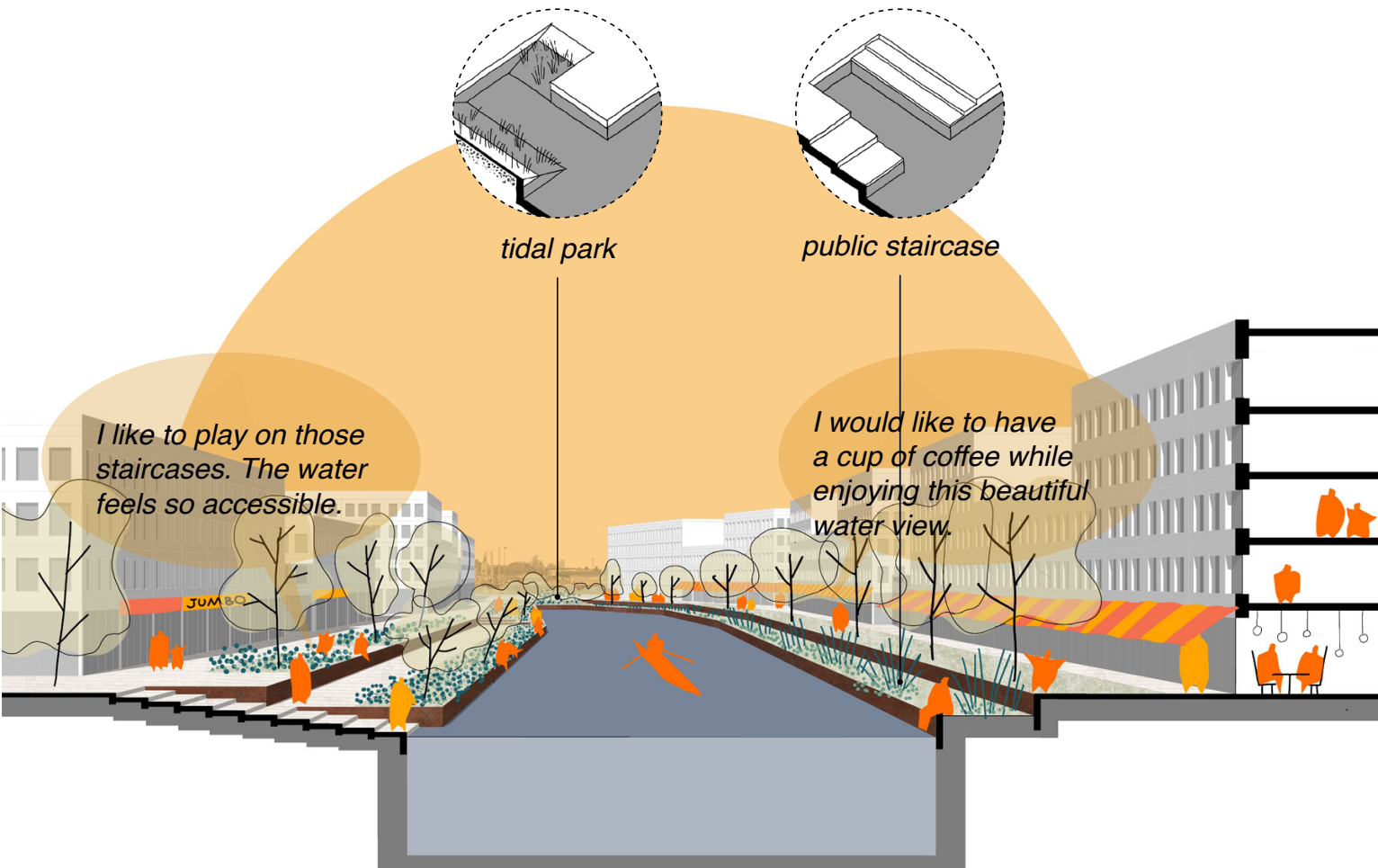
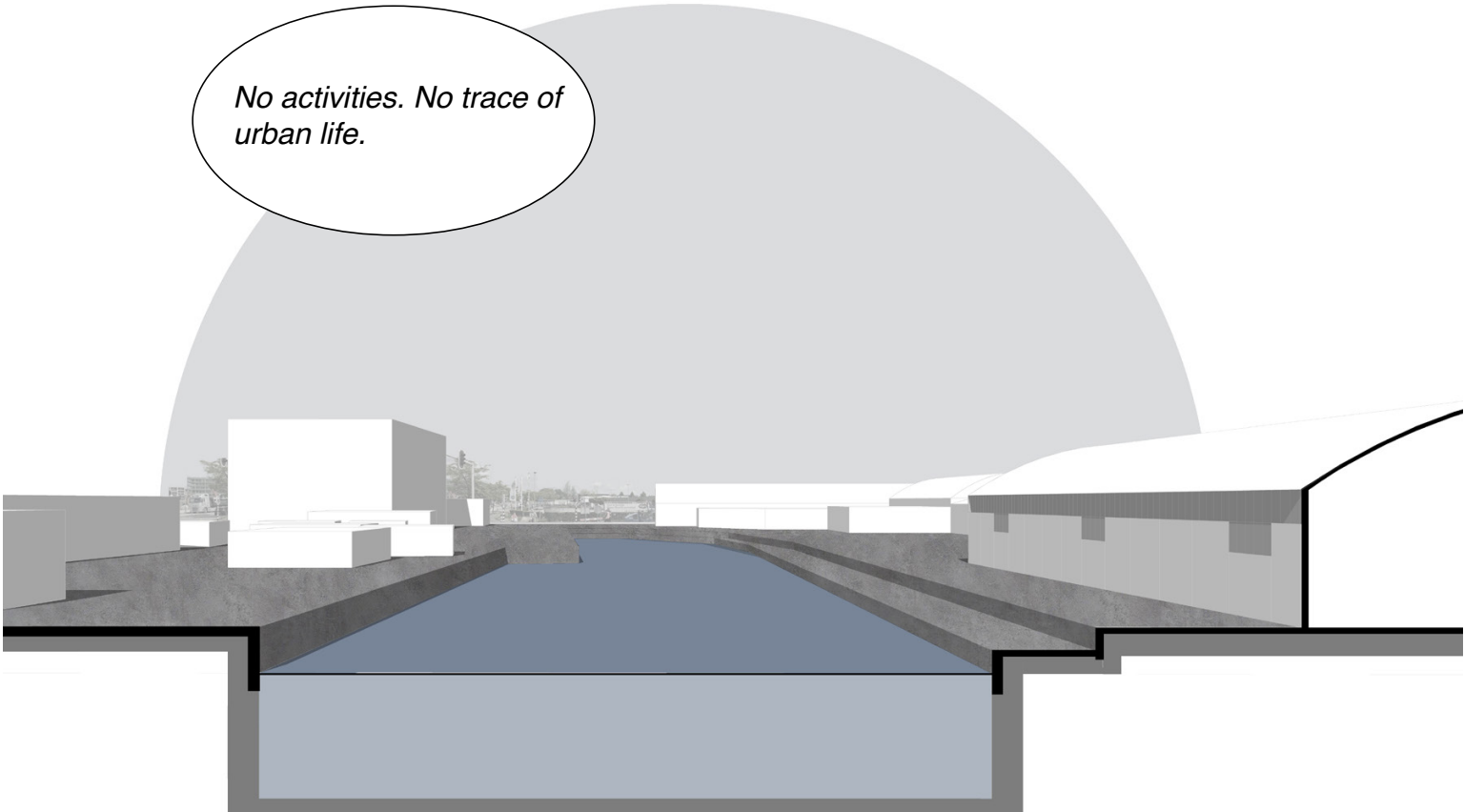

Integrated Design Proposal

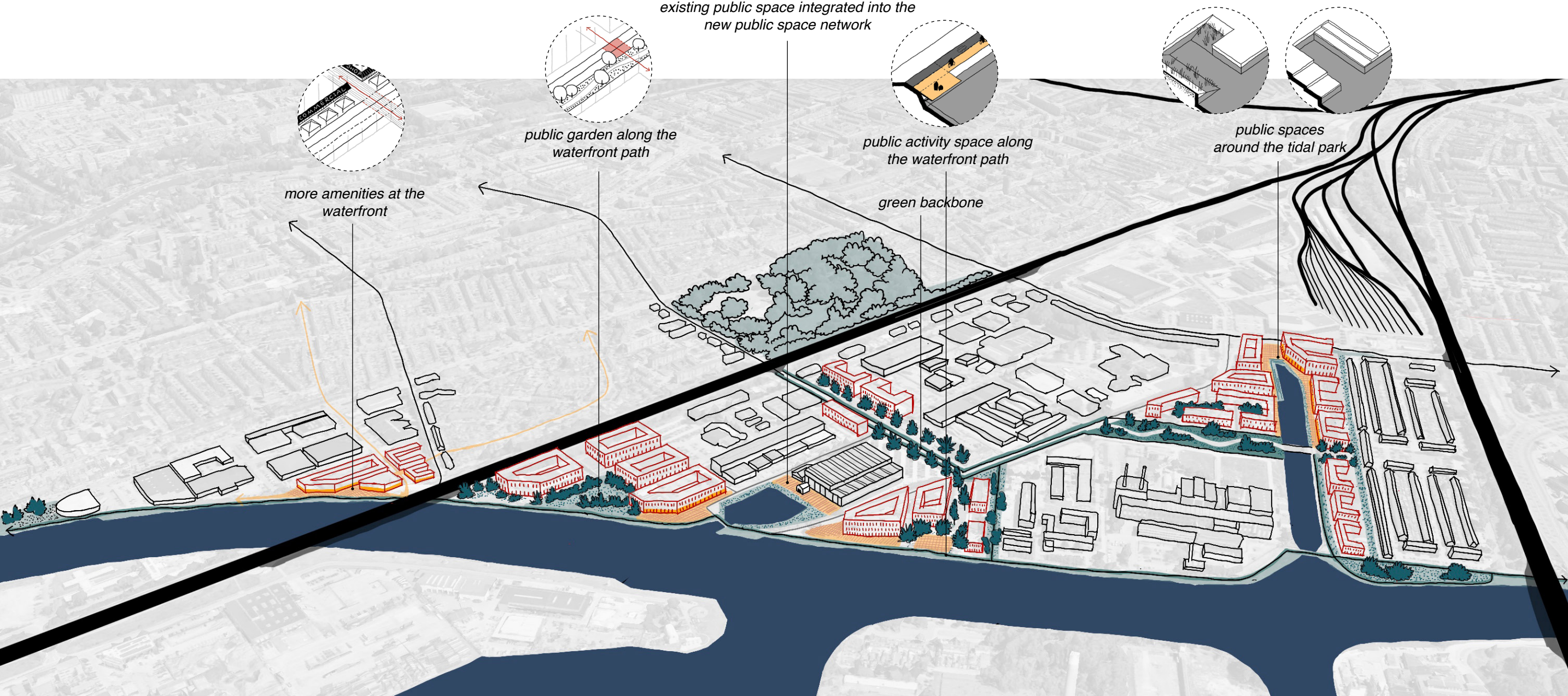

Detailed Design for Canal Side Pathway

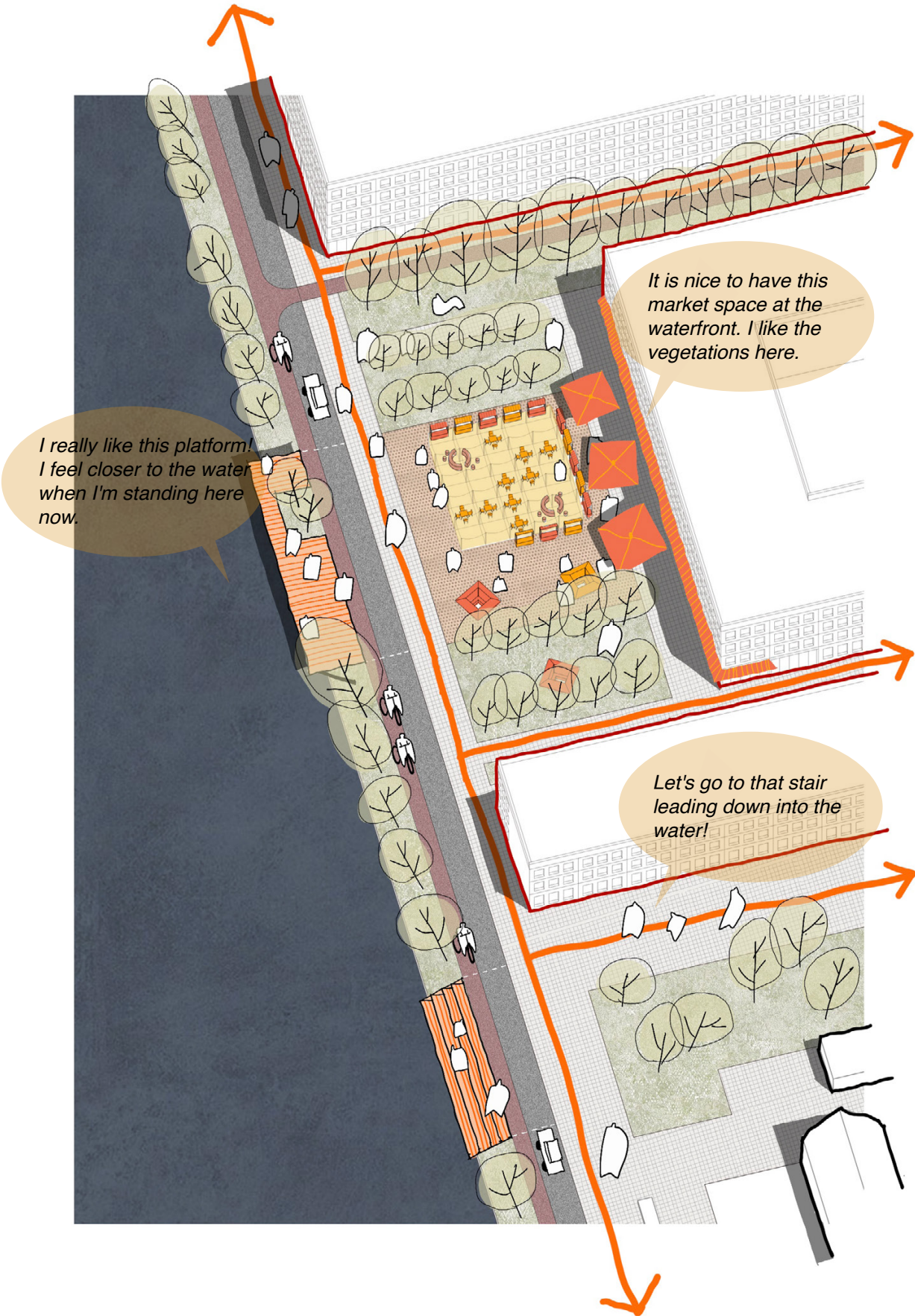

Detailed Design for Green Corridor

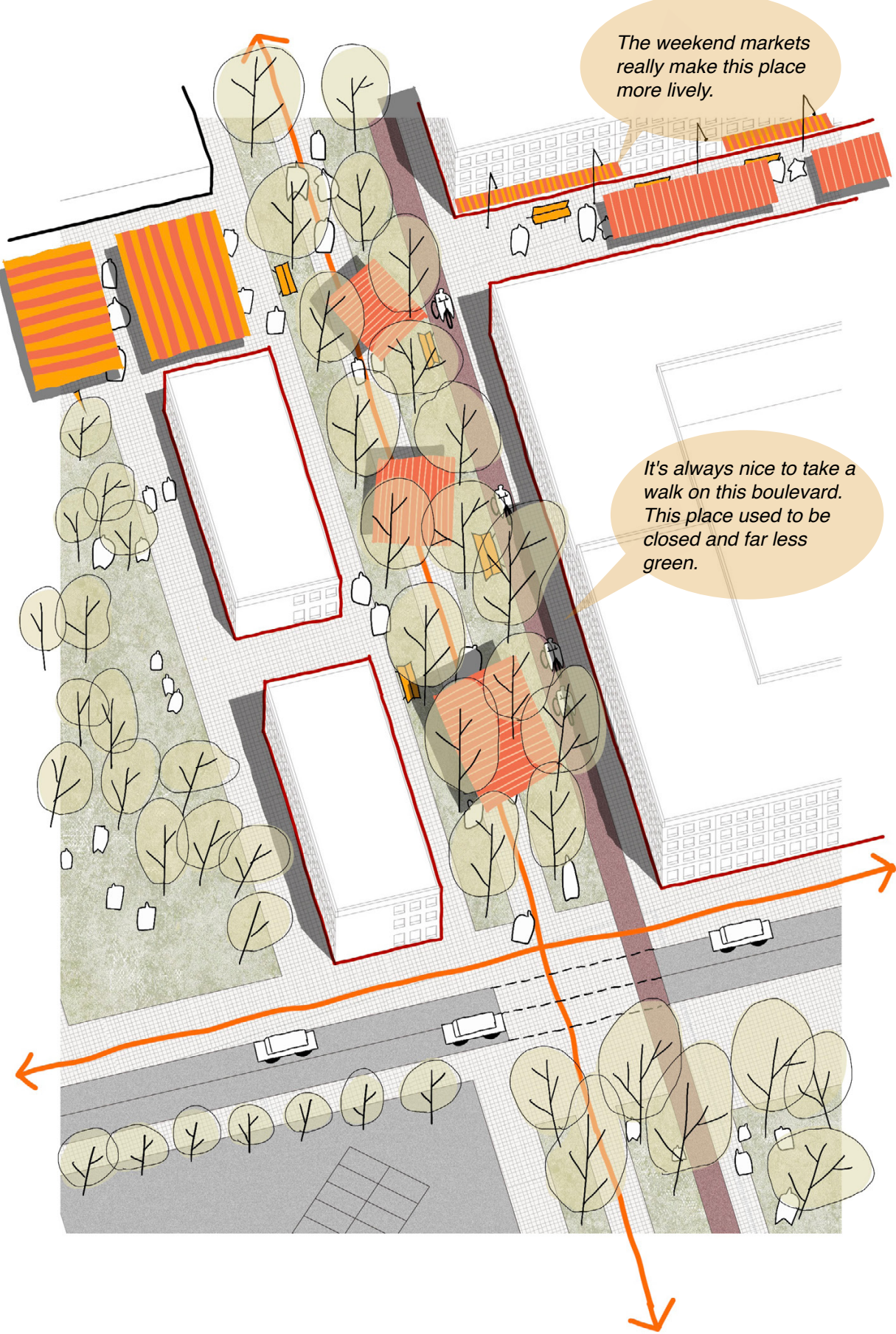

Assessment after Intervention

Segment 1 Amenity density imbalance

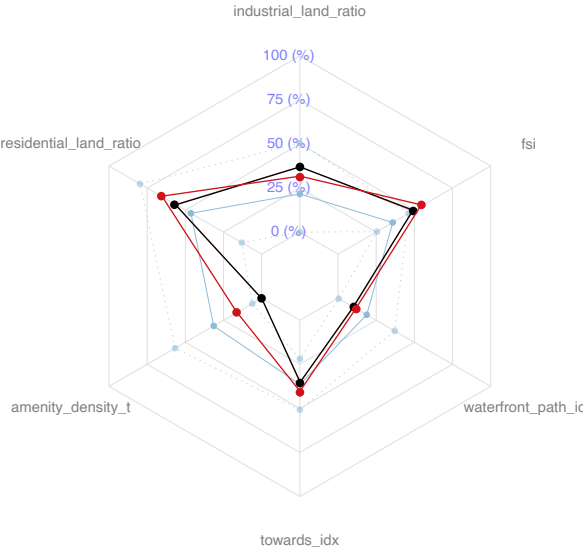

Segment 2 industrial landuse imbalance

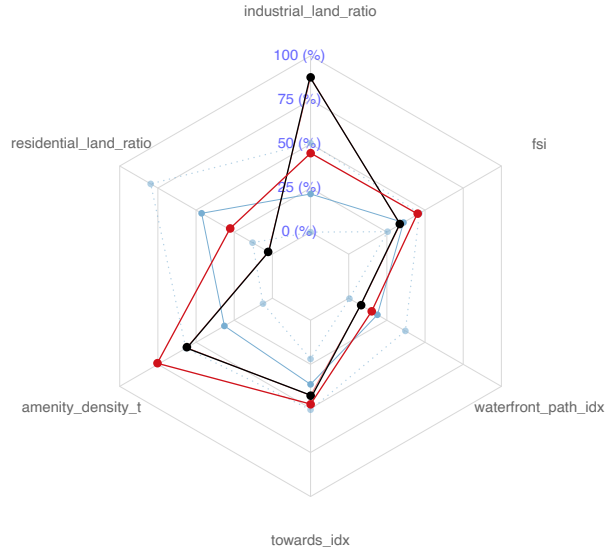

— before intervention — after intervention

Integrated Design Proposal in Roosendaal

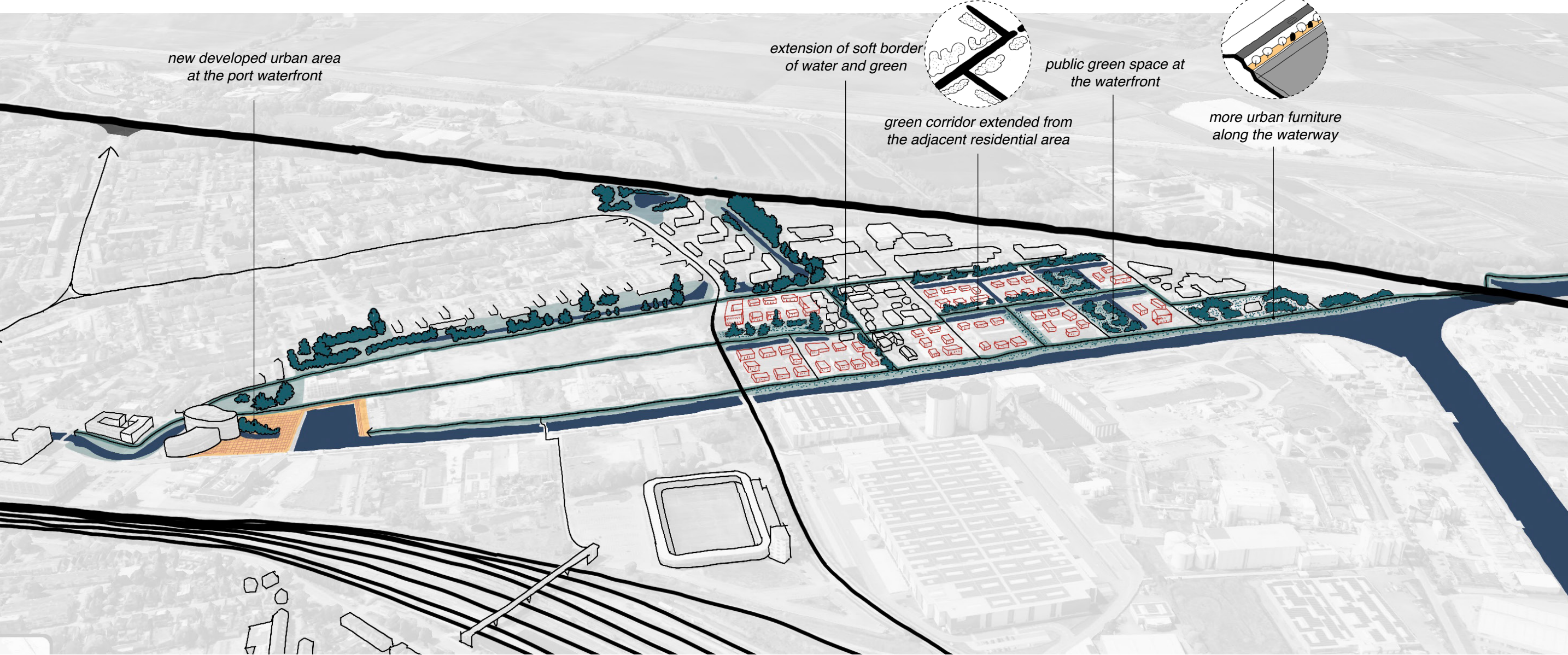

Integrated Design Proposal in Tilburg

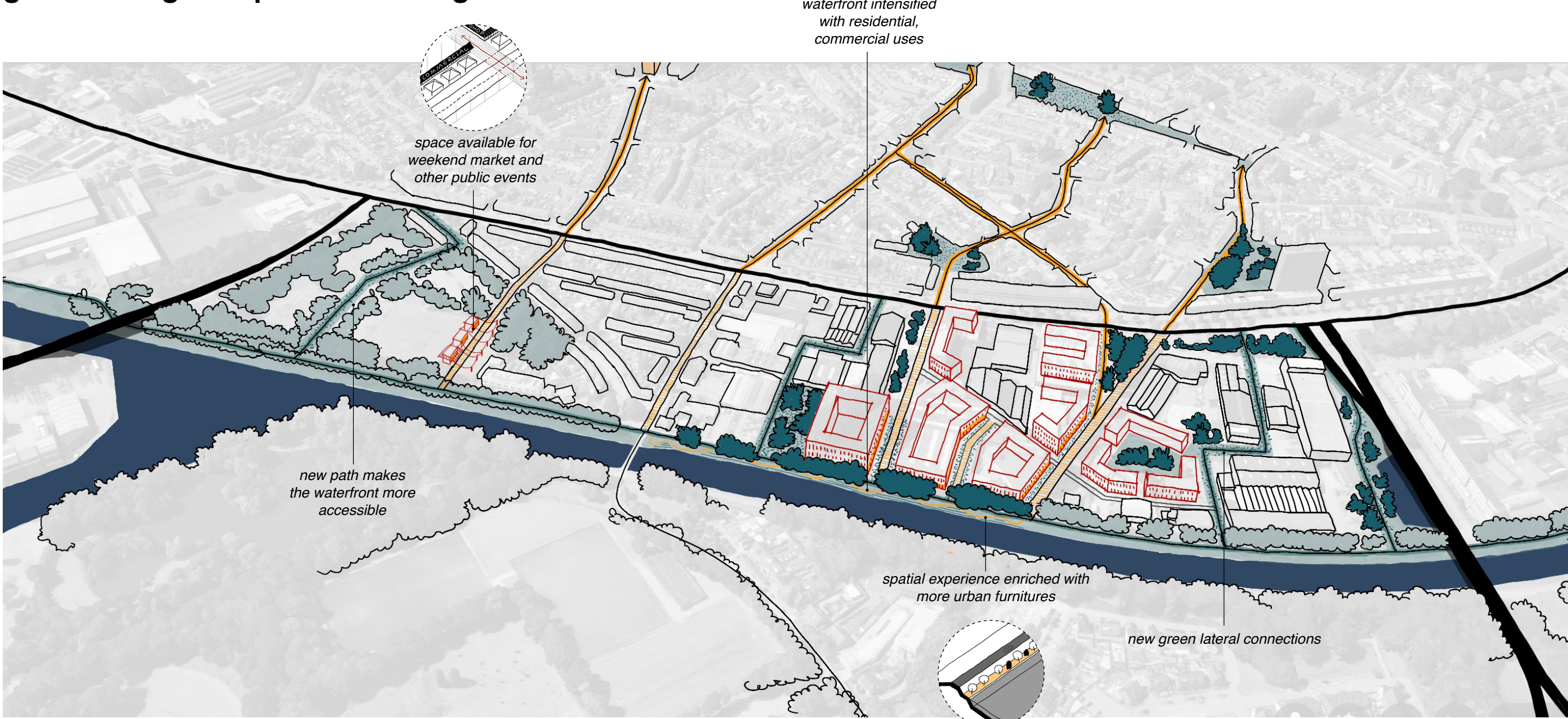

Conclusion

Multi-Scalar Framework

How can **waterfront transformation potential** in industrial inland port cities be identified through a **multi-scalar framework** to cultivate a more **adaptive and resilient port-cityscape**?

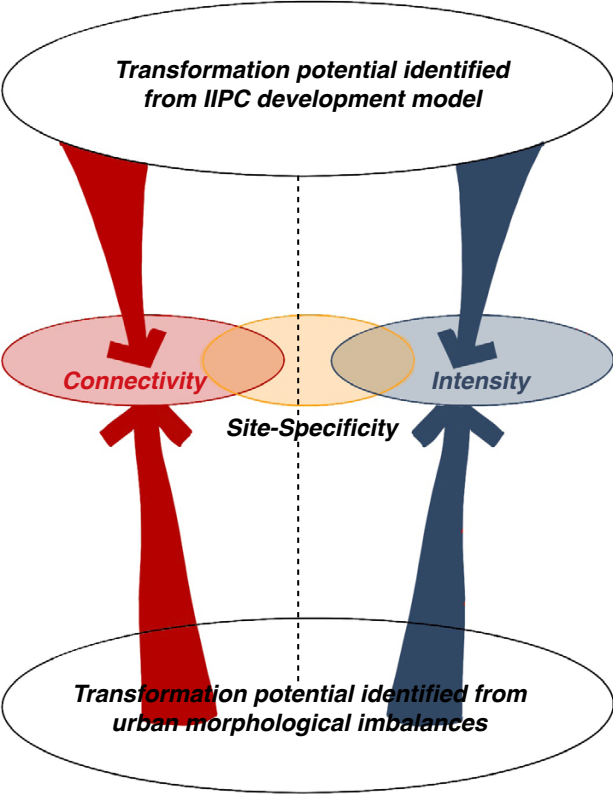
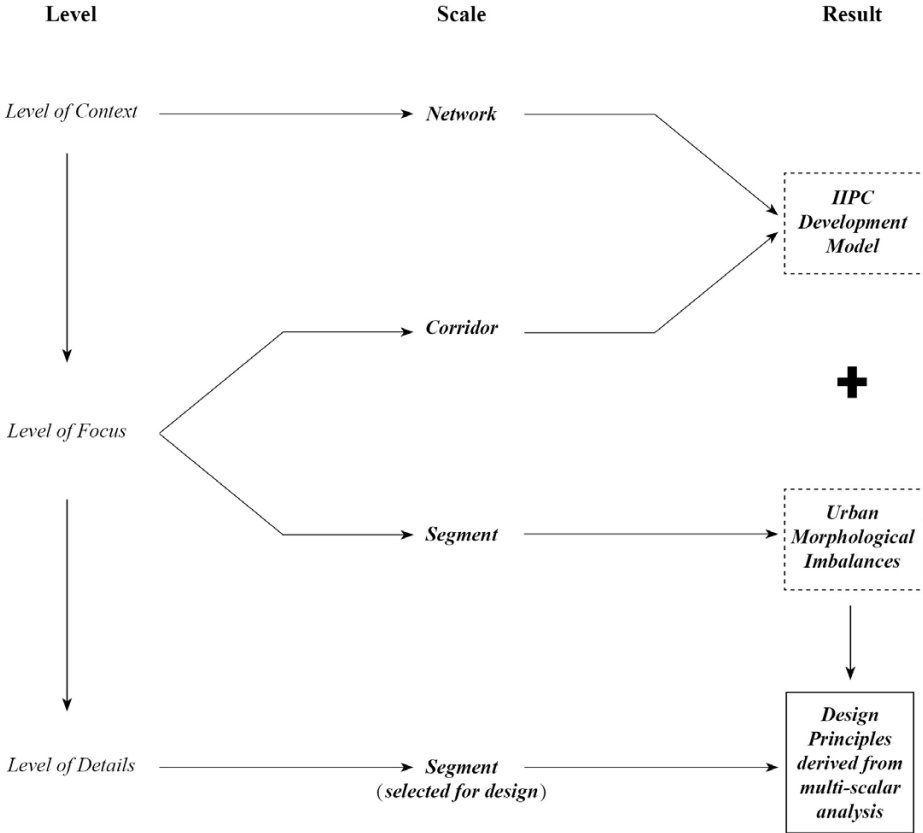

Conclusion

Breaking Down Waterfront Transformation Potential

How can **waterfront transformation potential** in industrial inland port cities be identified through a **multi-scalar framework** to cultivate a more **adaptive and resilient port-cityscape**?

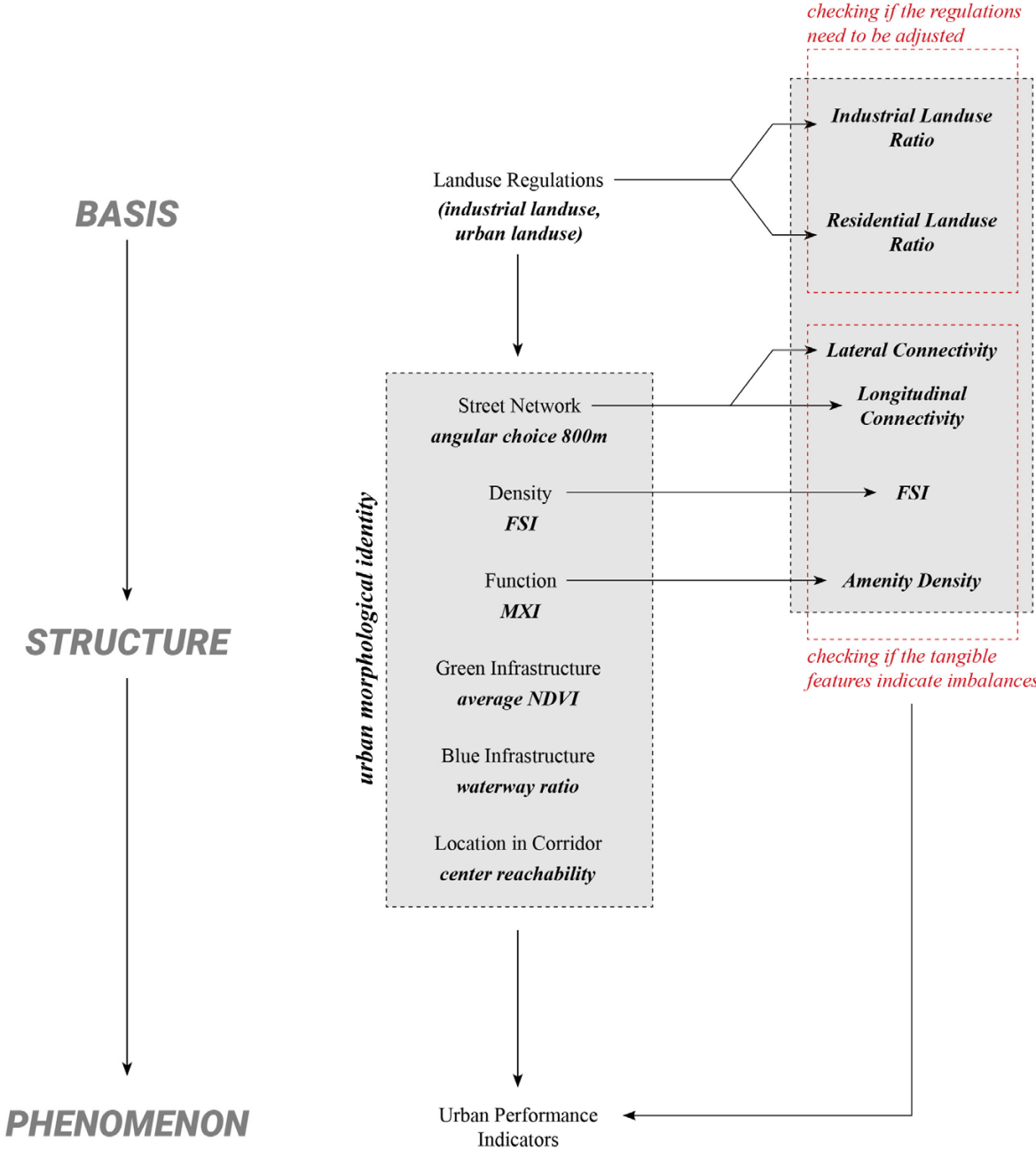

Conclusion

Assessment after Intervention

How can **waterfront transformation potential** in industrial inland port cities be identified through a **multi-scalar framework** to cultivate a more **adaptive and resilient port-cityscape**?

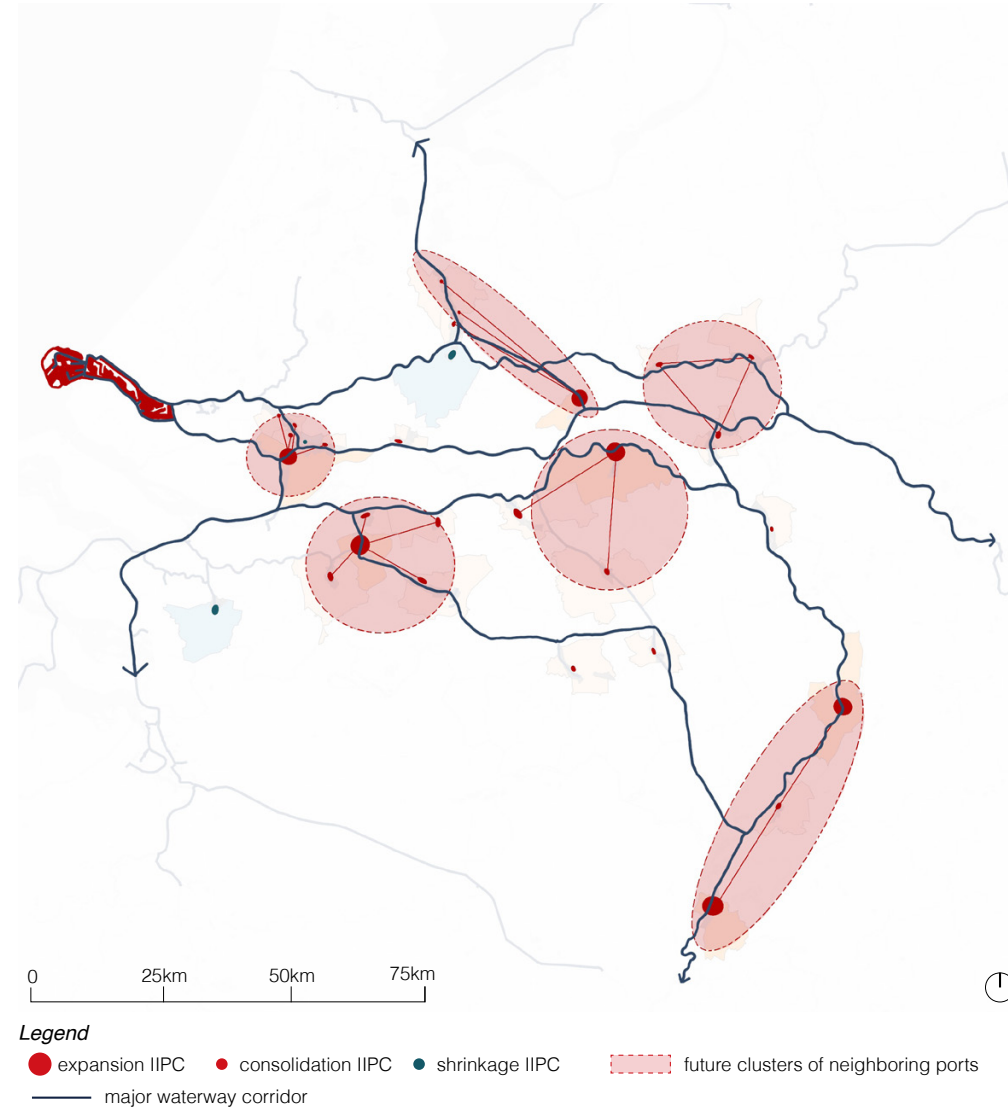

Segment 1 Amenity density imbalance

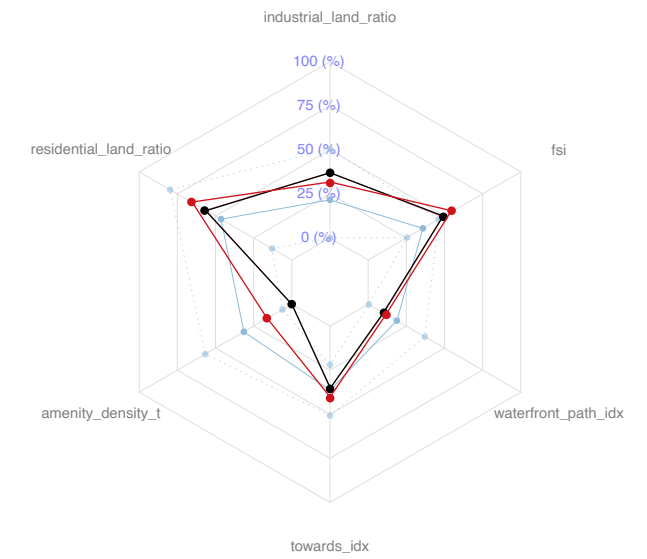

Segment 2 industrial landuse imbalance

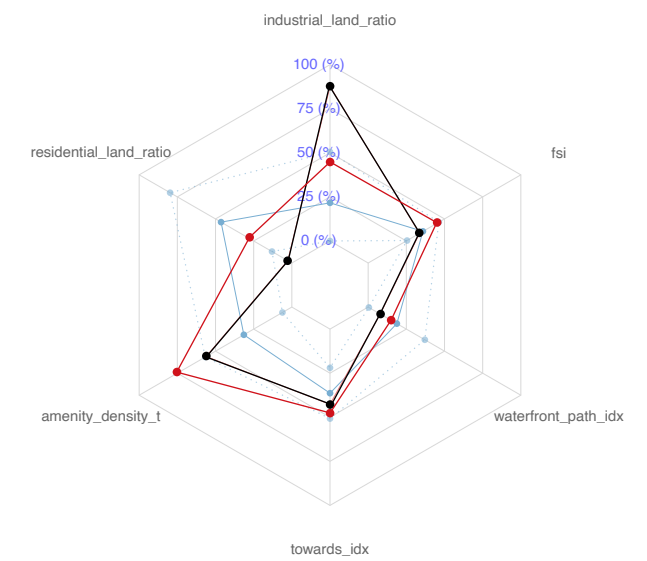

Thanks for listening!

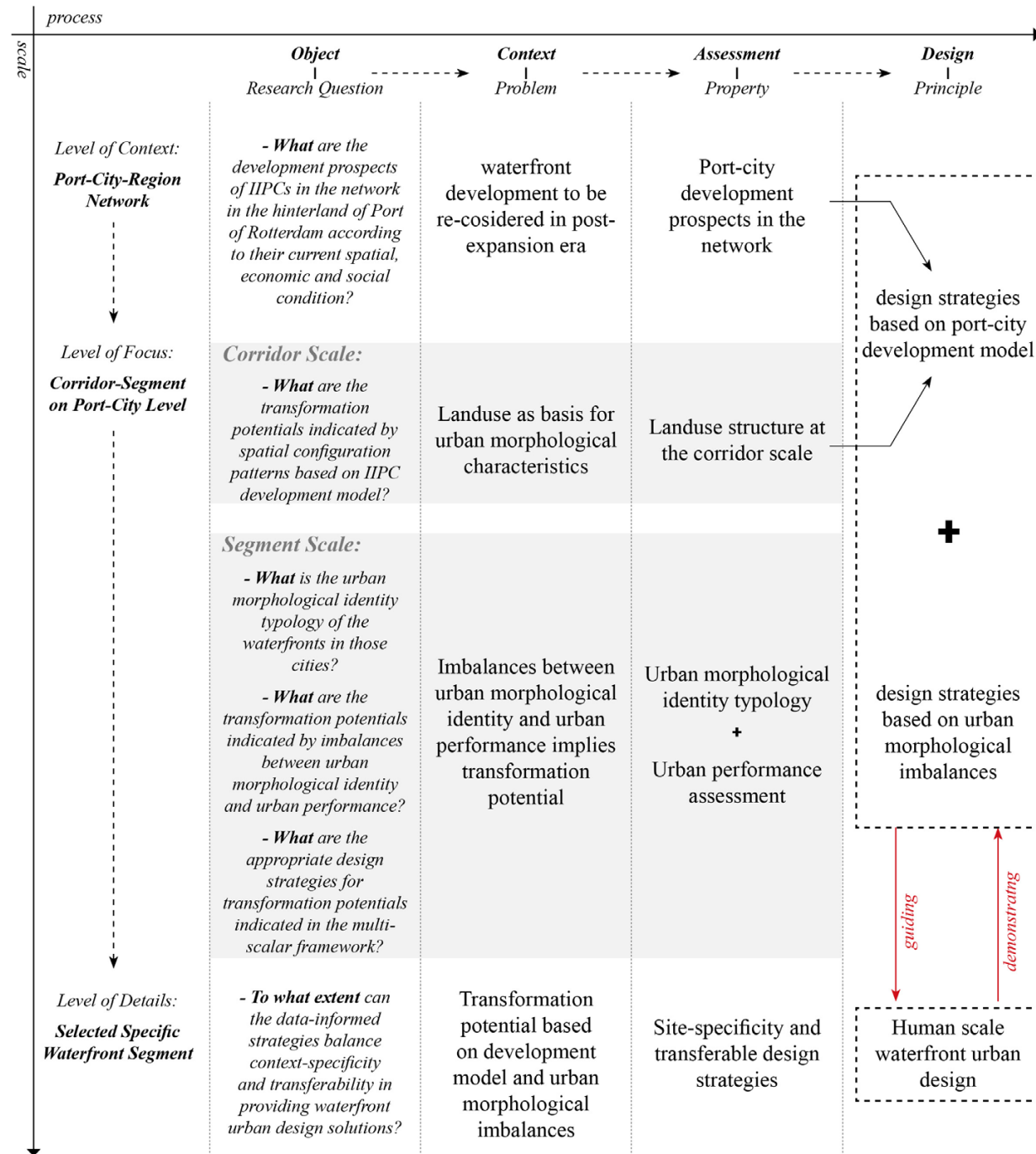

Fig. 5, Methodological framework

Included port-cities	
a. Ports with direct barge link with the Port of Rotterdam (Port of Rotterdam Authority, n.d.), and their associated municipality (Kadaster, 2024)	Ridderkerk, Alblasterdam, Dordrecht, Moerdijk, Berg op Zoom, Alphen aan de Rijn, Utrecht, Doesburg, Gorinchem, Tilburg, Oss, Sittard-Geleen, Roermond, Nijmegen, 's-Hertogenbosch, Tiel, Venlo, Wanssum, Meierijstad, Oosterhout, Waalwijk, Cuijk, Hendrik-Ido-Ambacht, Zwijndrecht, Papendrecht, Sliedrecht
b. Ports along the three major waterways (Lek-Nederrijn, Waal, Maas) which are not in a, and their associated municipality (Kadaster, 2024)	Arnhem, Molenlanden, Vijfheerenlanden, Nieuwegein, Wageningen, Renkum, Geertruidenberg, Genep
c. Ports with both canal link and major highway connection to port-cities in a and b (OSM, n.d.)	Eindhoven, Breda, Helmond, Roosendaal
Excluded port-cities	
d. Seaports (OSM, n.d.)	Berg op Zoom
e. Ports not relevant with the connection from the Port and Rotterdam to upstream industrial hinterland	Alphen aan de Rijn, Doesburg
f. Ports and urban areas isolated by considerable distance	Wanssum
g. Municipalities with urbanization area size not sufficient for this study	Wanssum, Moerdijk, Molenlanden, Cuijk, Renkum

Table 1, Rules of inclusion and exclusion of IIPCs

Table 2. The definition of various categories in the final combination of space syntax, spacematrix and MXI

Types of urban areas	The values of Space Syntax, Spacematrix and MXI belonging to each type	Degree of Balance
1) Suburban	L/L/L, M/L/L, L/L/M, L/M/L	Balanced with low-values
2) Low-urban	L/M/M, M/L/M, M/M/L	
3) In-between (low)	H/L/L, L/H/L, L/L/H	
4) In-between (medium)	H/M/L, M/H/L, L/M/H, H/L/M, L/H/M, M/L/H	Unbalanced with mixed-values
5) In-between (high)	H/H/L, H/L/H, L/H/H	
6) Medium-urban	M/M/H, M/H/M, H/M/M, M/M/M	Balanced with high-values
7) Highly-urban	H/H/H, H/M/H, M/H/H, H/H/M	

L = Low value, M = Medium value, H = High value

Fig. 10, Urban Morphological imbalances identified in the study of Ye and van Nes

1. <i>What are the development prospects of IIPCs in the network in the hinterland of Port of Rotterdam according to their current spatial, economic and social condition?</i>	Objective 1.1	Identify perspectives of port and urban area development
	Objective 1.2	Categorize IIPCs according to development prospects
	Objective 1.3	Analyze development dynamics in the network

Table 2, Research question and objectives at the level of context

Aspects	Criteria	Unit
Social criteria	Population growth dynamics	Municipality
Economical criteria	Port type GDP trend	Port
	Multimodal connection availability	Port
	Functional diversity of port	Port
	Scale of the port	Port
	Sector GDP trend of the port	Port
Spatial criteria	Port expansion dynamic	Port

Table 3, Variables for clustering at the level of context

Categories of IIPC	Description	Strategic Implications
Expansion	Future urban expansion hotspot in the logistics network: occupy strategic positions, enjoy priority in infrastructure investment; in turn stimulating the expansion of surrounding residential areas and intensifying competition for waterfront spaces	An expansion direction of industrial ports should be planned along the waterfront; The social and environmental performance should be enhanced in the rest of the waterfront space
Consolidation	Ports located close to the city, with constrained expansion possibility, can be transformed into urban circularity hubs; waterfront spaces with non-core industrial uses offer potential for mixed-use redevelopment	The waterfront space in-between the current port-in operation and the urban core can accommodate mixed-use development to enhance the system performance
Shrinkage	small, mono-functional ports may face functional transformation and redevelopment	The industrial waterfront can be transformed into other use

Table 4, Categories of IIPCs at the level of context

Sub-question 1	<i>What are the development prospects of IIPCs in the network in the hinterland of Port of Rotterdam according to their current spatial, economic and social condition?</i>		
Objective 1.1	Identify perspectives of port and urban area development	Method	Policy analysis
Objective 1.2	Categorize IIPCs according to development prospects	Method	Data collection, k-prototype clustering
Objective 1.3	Analyze development dynamics in the network	Method	Mapping

Table 5, Objectives and methods at the level of context

2. <i>What are the transformation potentials indicated by spatial configuration patterns based on IIPC development model?</i>	Objective 2.1	Delineate corridor and segment of IIPCs
	Objective 2.2	Map the landuse structure and identify potential spatial configuration patterns
	Objective 2.3	Propose strategies for potential based on IIPC development model
3. <i>What is the urban morphological identity of the waterfronts in those cities?</i>	Objective 3.1	Collect data for selected variables and cluster to construct urban morphological identity typology
	Objective 3.2	Analyze cluster result and identify the clusters with potential
4. <i>What are the transformation potentials indicated by imbalances between urban morphological identity and urban performance?</i>	Objective 4.1	Diagnose the clusters with potential with urban performance assessment framework
	Objective 4.2	Identify imbalances
5. <i>What are the appropriate design strategies for transformation potentials indicated in the multi-scalar framework?</i>	Objective 5.1	Propose design strategies by overlapping the multi-scalar transformation potentials

Table 6, Research question and objectives at the level of focus

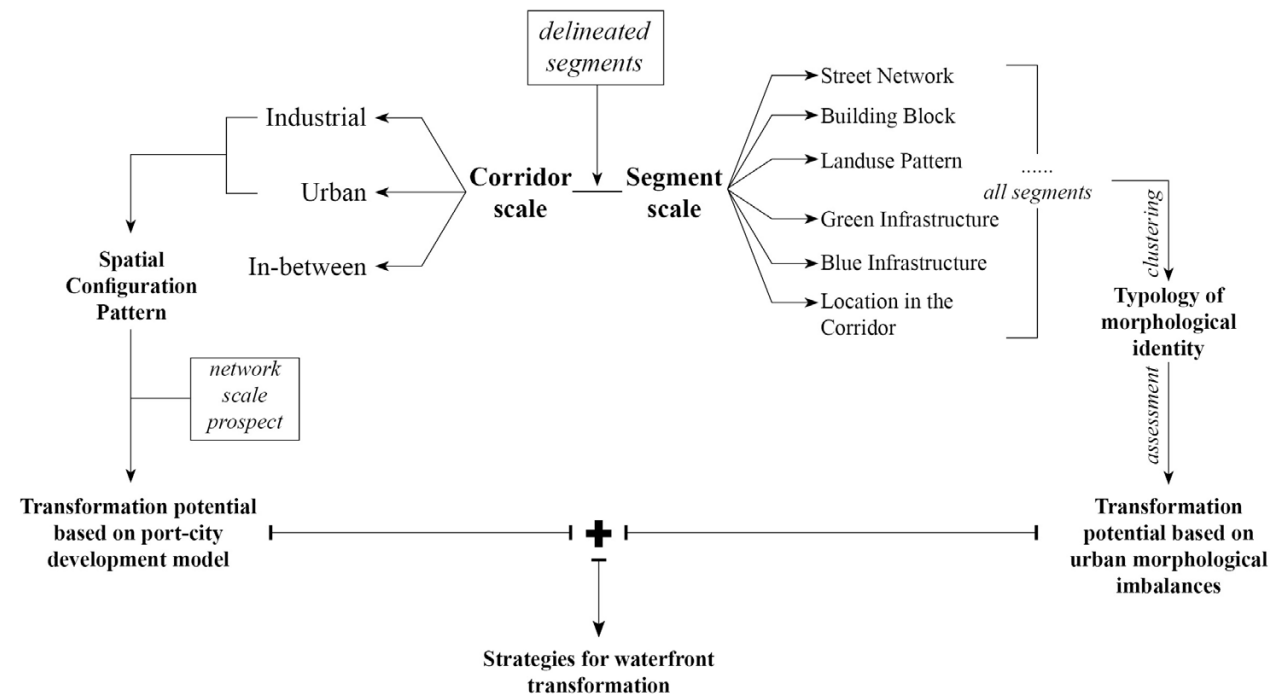

Fig. 13, Methods at the level of focus

Variables for clustering	Description	Aspect
Accessibility of each segment	Using space syntax to calculate the weighted sum of angular choice result (800m) of each segment	Street network
FSI	Using the data from Rudifun dataset from the dutch government, indicating the built density of the segments	Density
Mixed-use index	Using the data from Rudifun dataset from the dutch government, indicating how mix-used are the segments	Function
Average NDVI	Using satellite image to calculate the average NDVI of the area, indicating the health and density of vegetation	Green infrastructure
Waterway ratio	Using waterway data from PDOK to calculate the ratio of waterway length and perimeter of each segment, indicating the amount of accessible waterfront	Blue infrastructure
Center reachability	Using QNEAT to calculate how much area of each segment is within 15min walkable distance from the urban center	Location in the corridor

Table 7, Variables for clustering at the scale of segment

Dimensions of assessment	Description	Aspect
Industrial landuse ratio	For segments already having an identity of higher waterfront transformation potential, the landuse regulation could be adjusted if industrial ratio is too high	Landuse regulation
Residential landuse ratio	For segments with higher residential land ratio but categorized into lower urbanity cluster, an integrated intervention is required	Landuse regulation
Amenity density	Segments with higher waterfront transformation potential but with lower amenity density may need more multi-function development	Function performance
Built density	Segments with higher waterfront transformation potential but with lower built density could be densified	Density performance
Lateral connectivity	Segments with higher waterfront transformation potential but with lower lateral connectivity may need intervention on street network	Connectivity performance
Waterfront path density	Segments with higher waterfront transformation potential but with lower waterfront path density may need more waterfront pedestrians	Connectivity performance

Table 8, Dimensions of assessment framework at the scale of segment

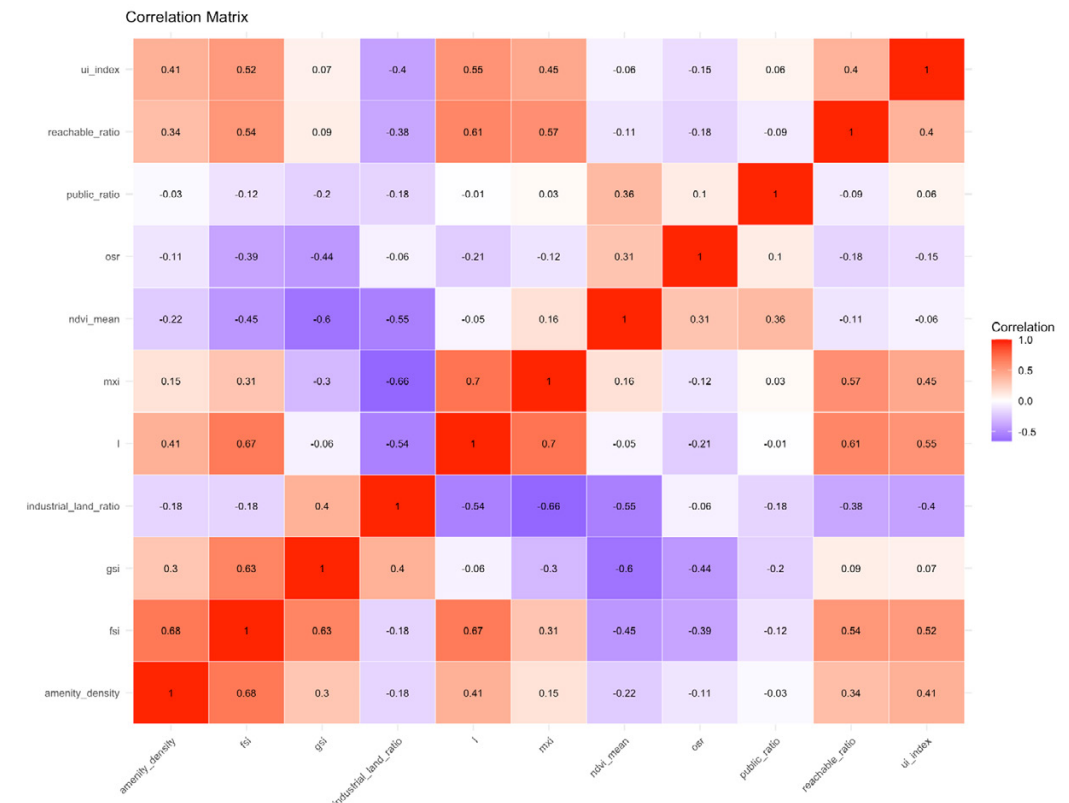

Sub-question 2 <i>What are the transformation potentials indicated by spatial configuration patterns based on port-city development model?</i>			
Objective 2.1	Delineate corridor and segment of IIPCs	Method	Rcrisp
Objective 2.2	Map the landuse structure and identify potential spatial configuration patterns	Method	mapping
Objective 2.3	Propose strategies for potential based on port-city development model	Method	Design
Sub-question 3 <i>What is the urban morphological identity typology of the waterfronts in those cities?</i>			
Objective 3.1	Collect data for selected variables and cluster to construct urban morphological identity typology	Method	DBSCAN, satellite image processing, urban data analysis, k-means clustering
Objective 3.2	Analyze cluster result and identify the clusters with potential	Method	Statistical analysis, box-plot, PCA analysis
Sub-question 4 <i>What are the transformation potentials indicated by imbalances between urban morphological identity and urban performance?</i>			
Objective 4.1	Diagnose the clusters with potential with urban performance assessment framework	Method	Urban data analysis, Statistical analysis, radar chart plotting
Objective 4.2	Identify imbalances	Method	Statistical analysis
Sub-question 5 <i>What are the appropriate design strategies for transformation potentials indicated in the multi-scalar framework?</i>			
Objective 5.1	Propose design strategies by overlapping the multi-scalar transformation potentials	Method	Analysis and design

Table 9, Objectives and methods at the level of focus

6. <i>To what extent can the data-informed strategies balance context-specificity and transferability in providing waterfront urban design solutions?</i>	Objective 5.1	Analyze site-specificity for each design case
	Objective 5.2	Propose human scale urban design for selected segments

Table 10, Research question and objectives at the level of details

Sub-question 6 <i>To what extent can the waterfront typology balance context-specificity and transferability in informing waterfront urban design solutions?</i>			
Objective 5.1	Analyze site-specificity for each design case	Method	Mapping and spatial analysis
Objective 5.2	Propose human scale urban design for selected segments	Method	Design

Table 11, Objectives and methods at the level of details

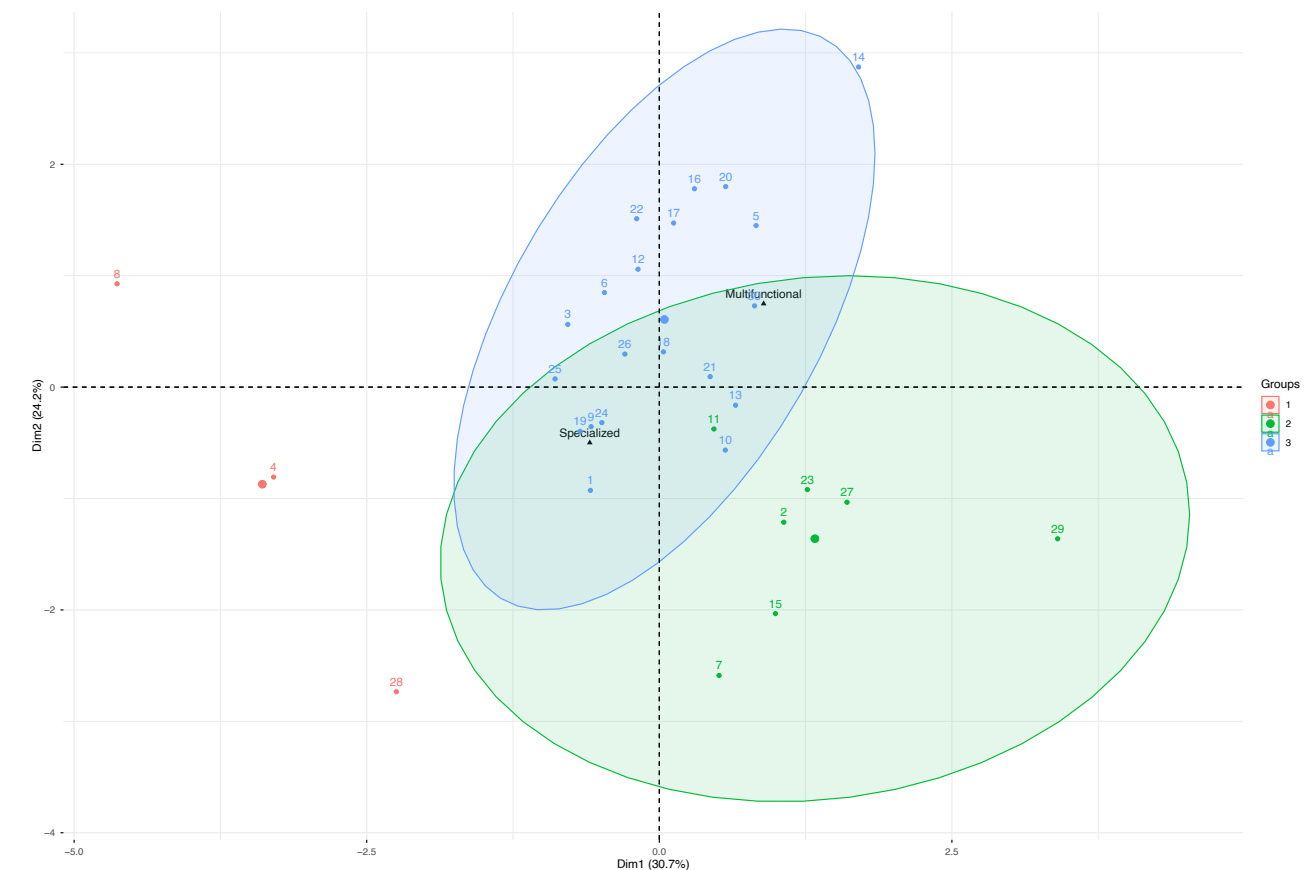

Fig. 15, K-Prototype clustering result of development prospects of the selected port-cities

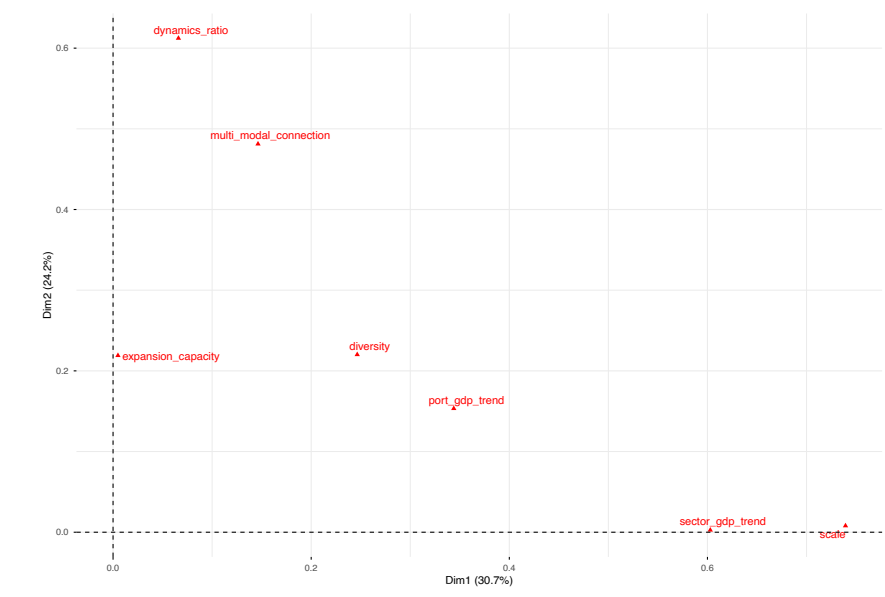
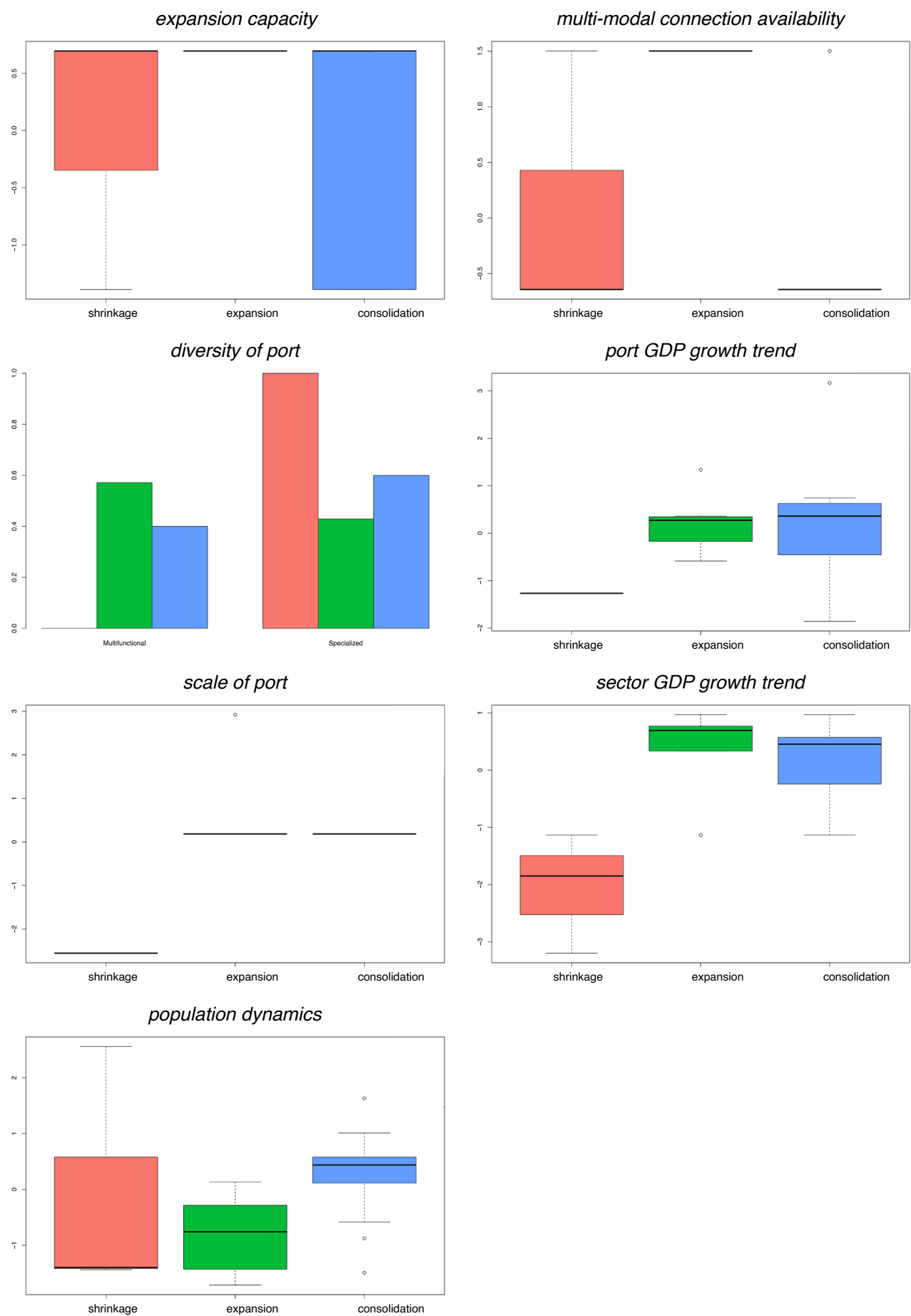

Fig. 17, Correlation between the two principal axes and each of the selected variables

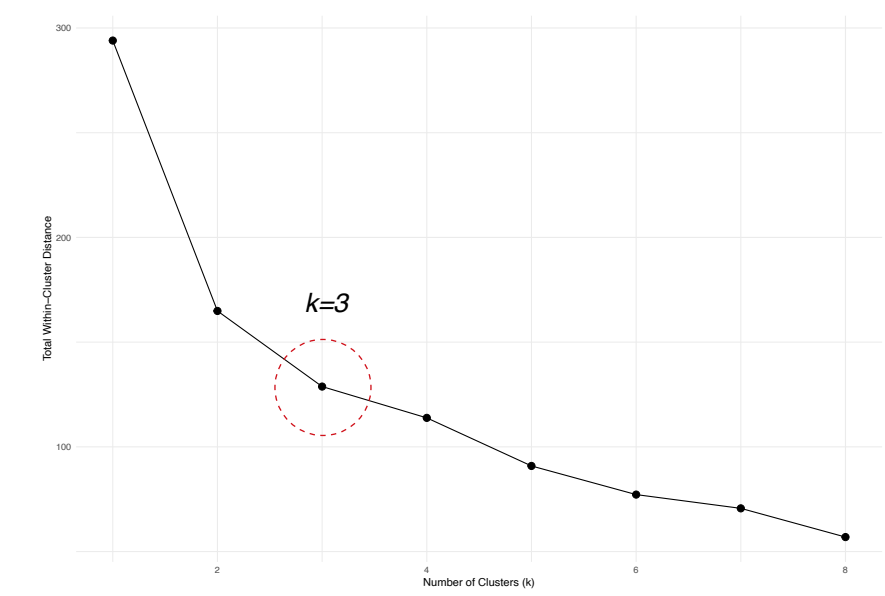

Fig. 18, Total within-cluster distance of different number of clusters

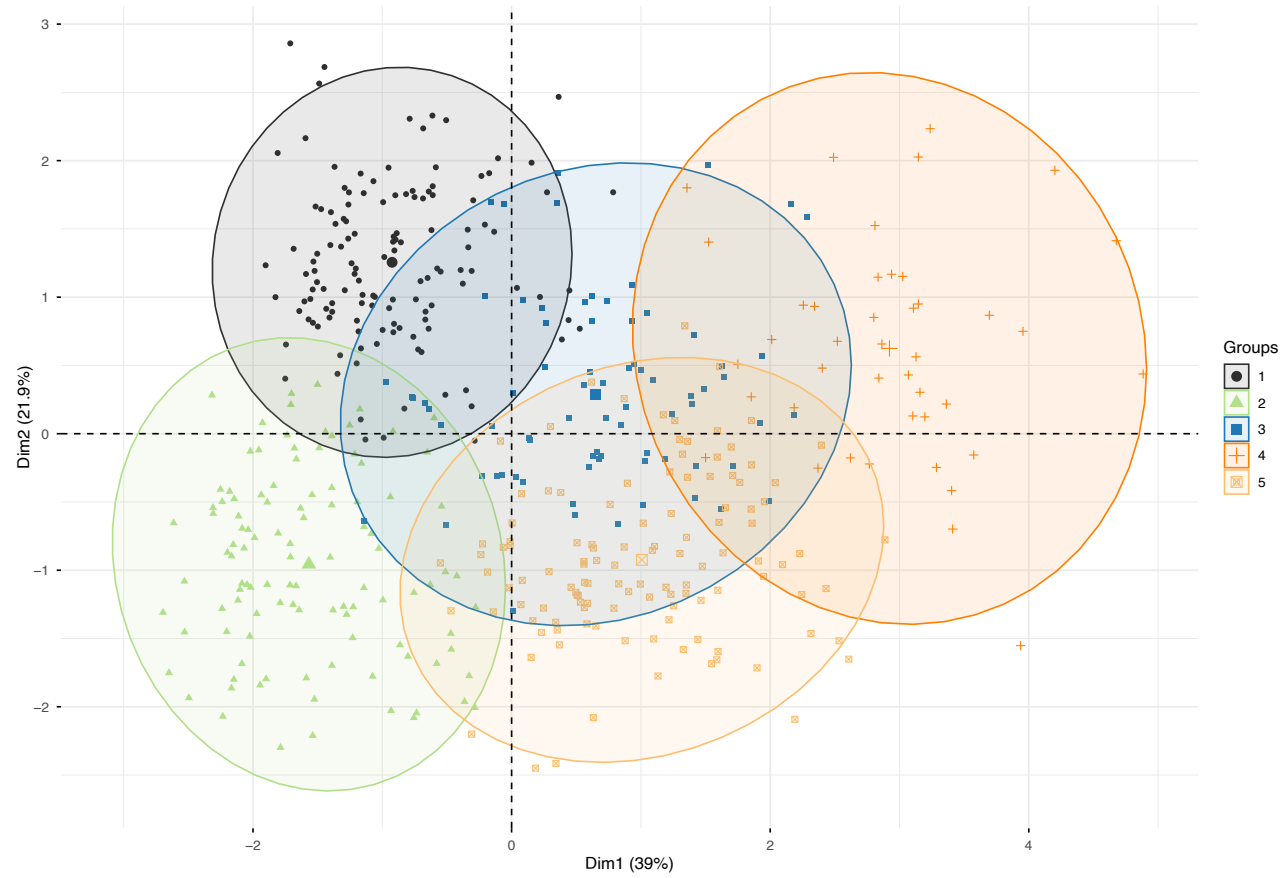

Fig. 27, K-means clustering result of urban morphological identity

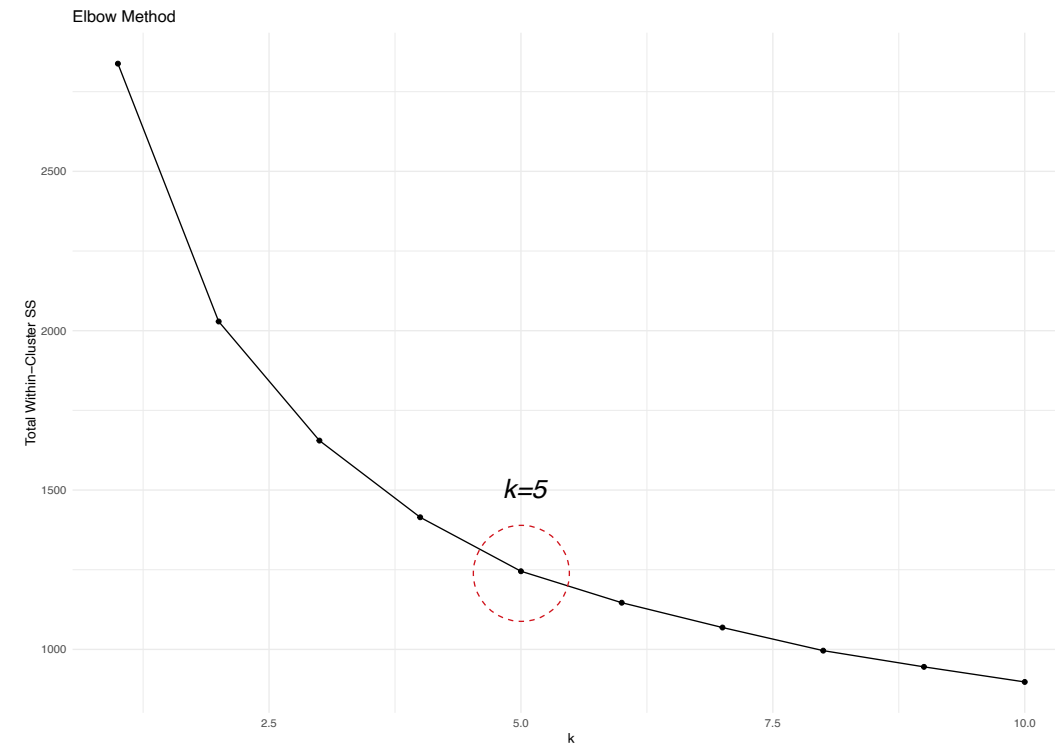

Fig. 28, Total within-cluster distance for different number of clusters

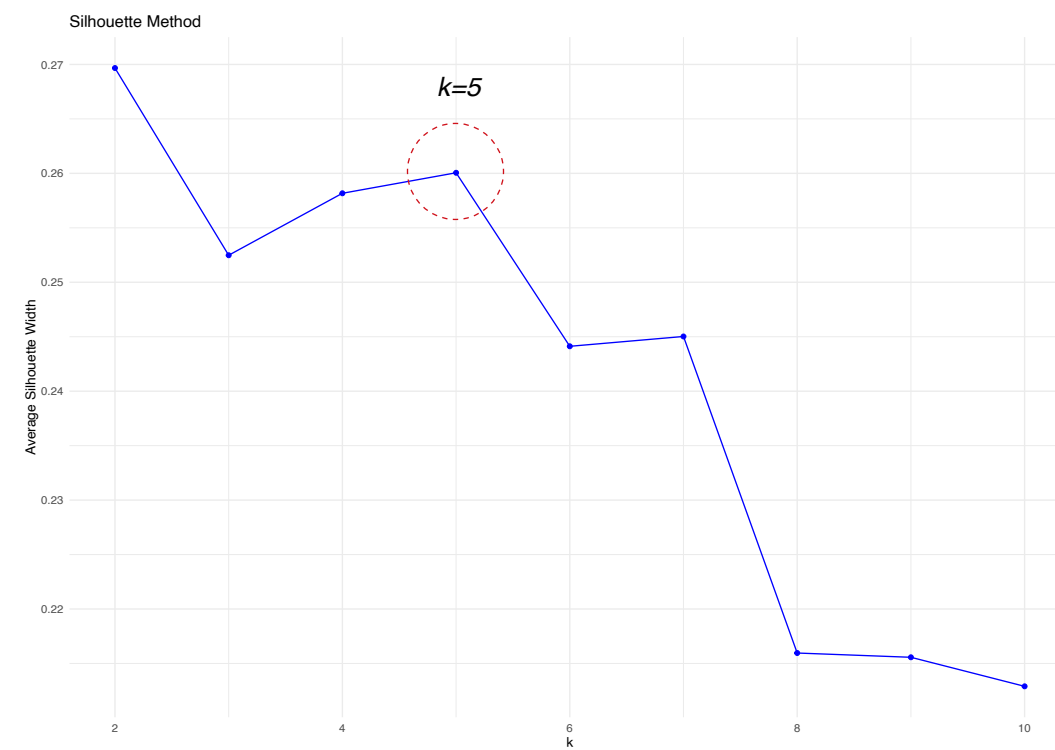

Fig. 29, Average silhouette width for different number of clusters

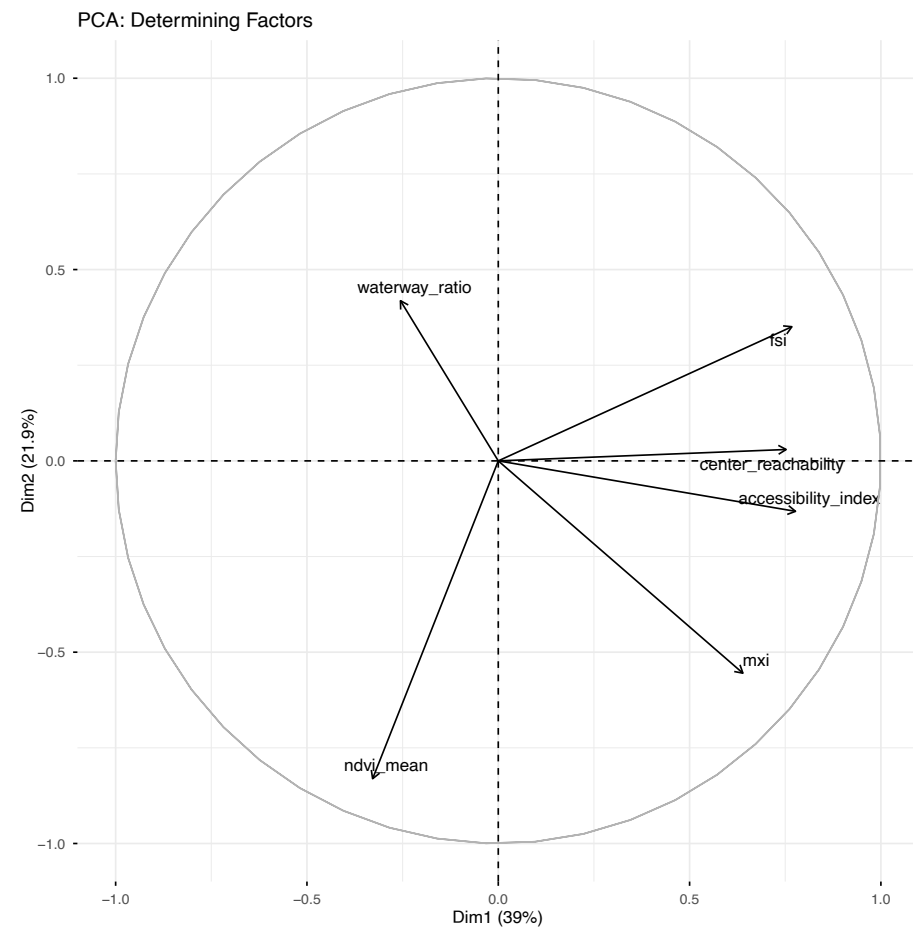

Fig. 30, Principle component analysis: determining factors

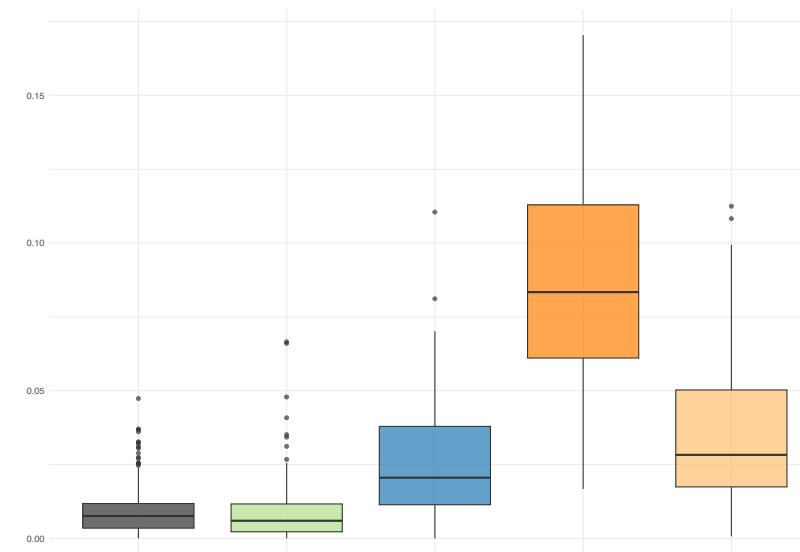

Fig. 31a, Accessibility index distribution

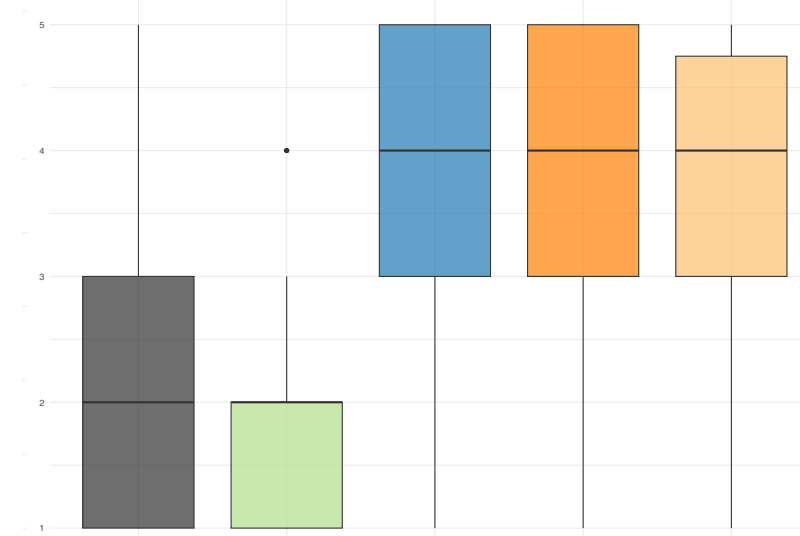

Fig. 31b, Center reachability distribution

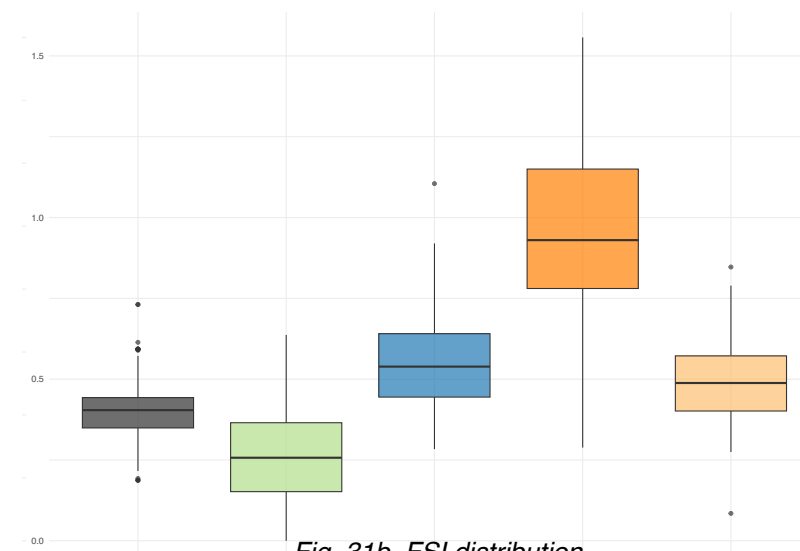

Fig. 31b, FSI distribution

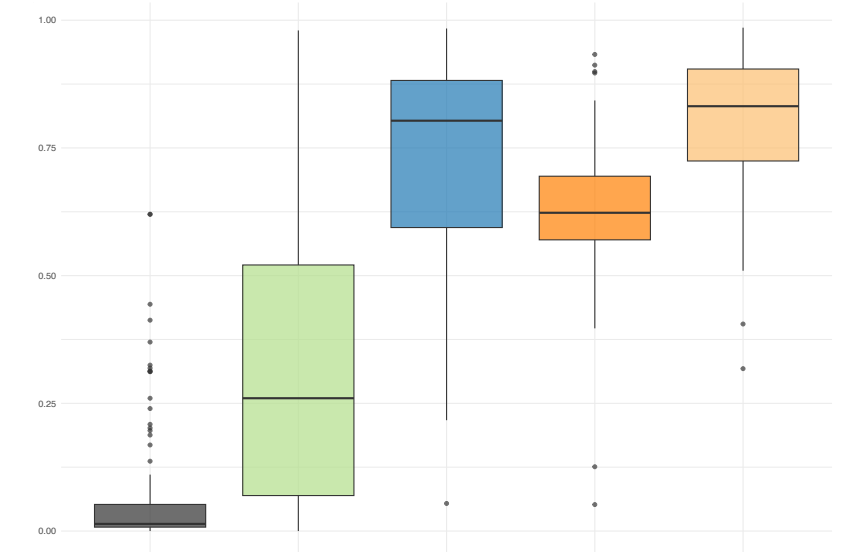

Fig. 31d, MXI distribution

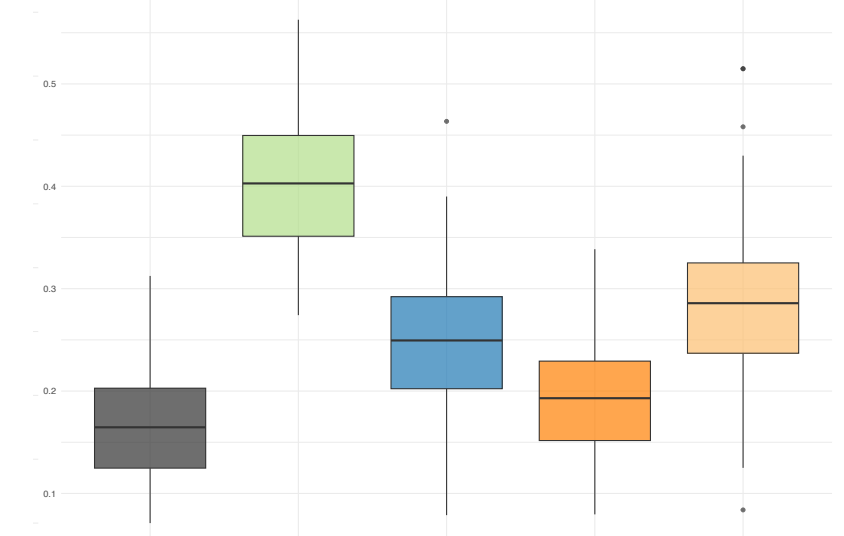

Fig. 31e, Average NDVI distribution

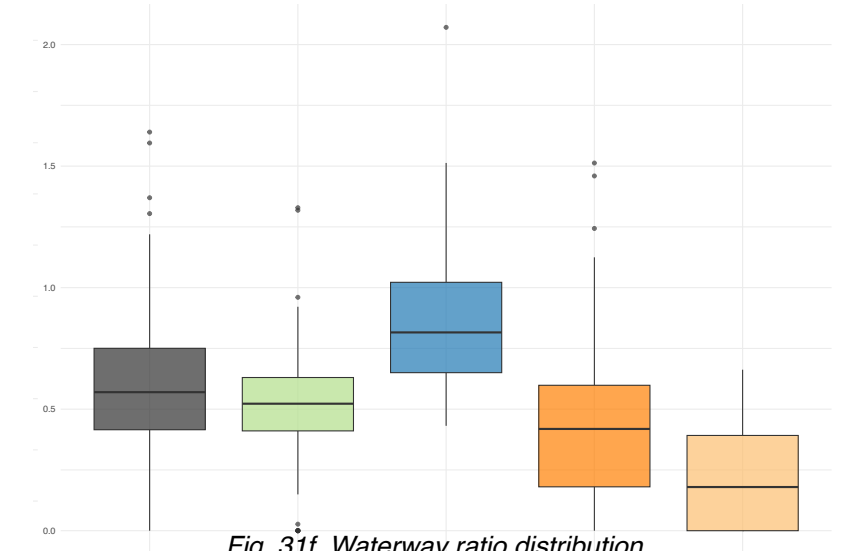

Fig. 31f, Waterway ratio distribution



Alblasterdam



Arnhem

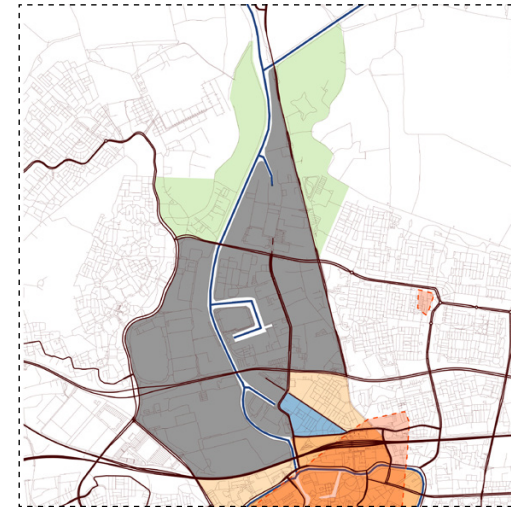

Breda



Dordrecht

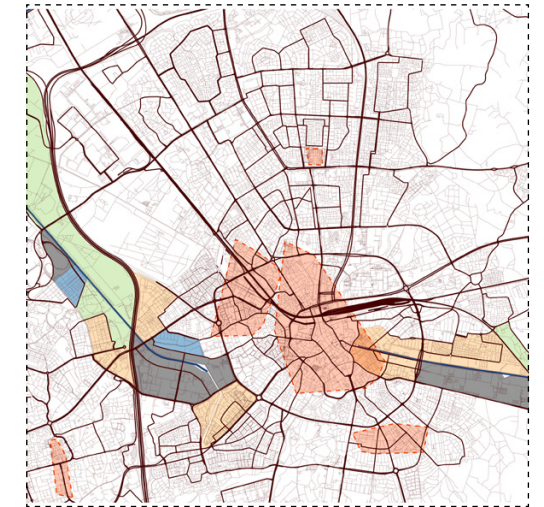

Eindhoven

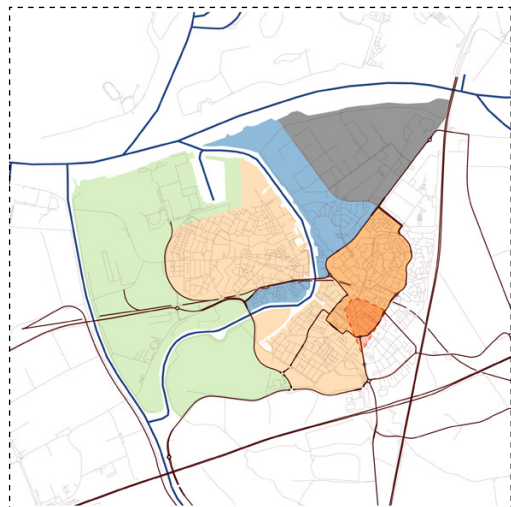

Geertruidenberg



Gennepe

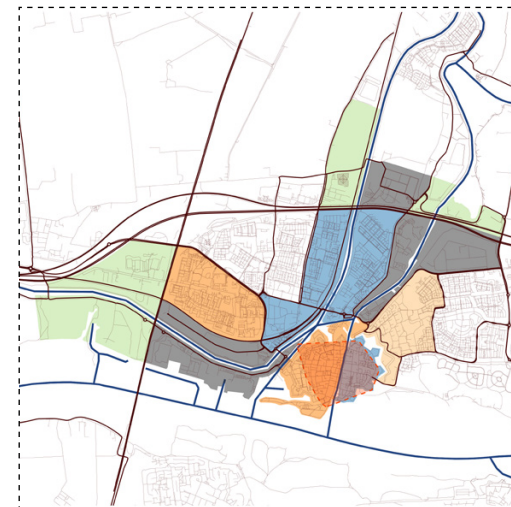

Gorinchem



Helmond



Hendrik-Ido-Ambacht

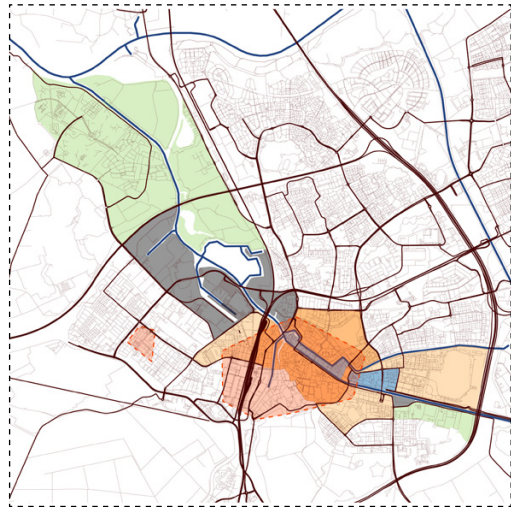

's-Hertogenbosch

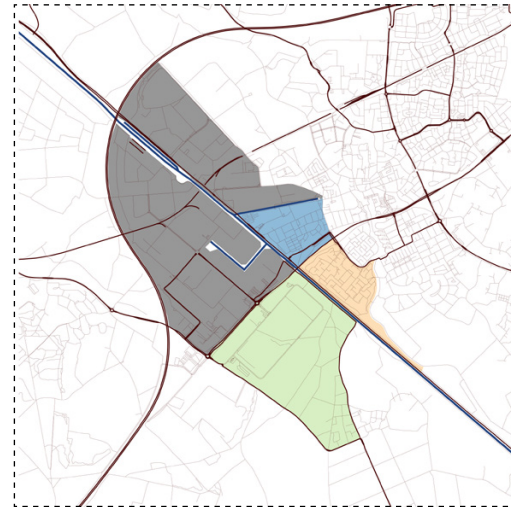

Meierijstad



Nieuwegein

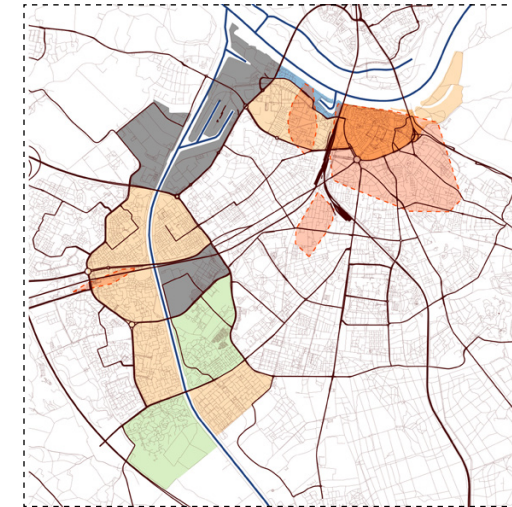

Nijmegen

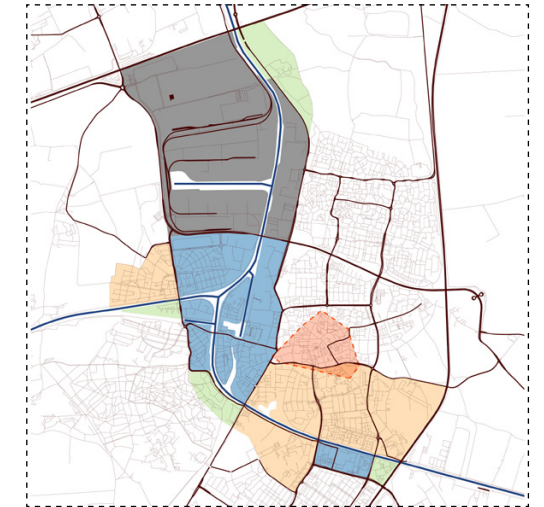

Oosterhout

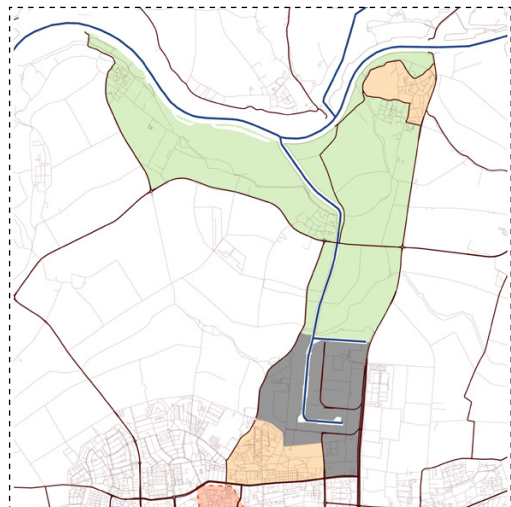

Oss



Papendrecht

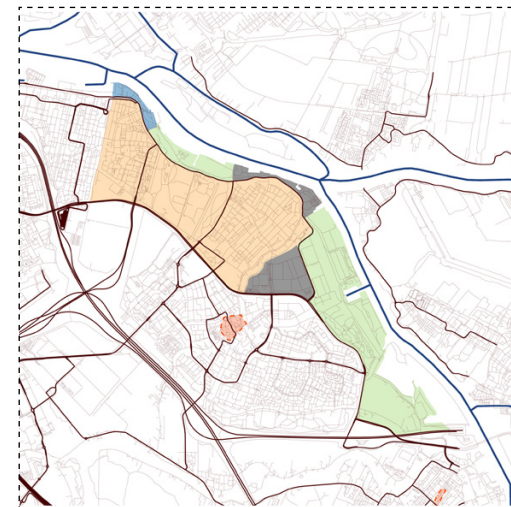

Ridderkerk

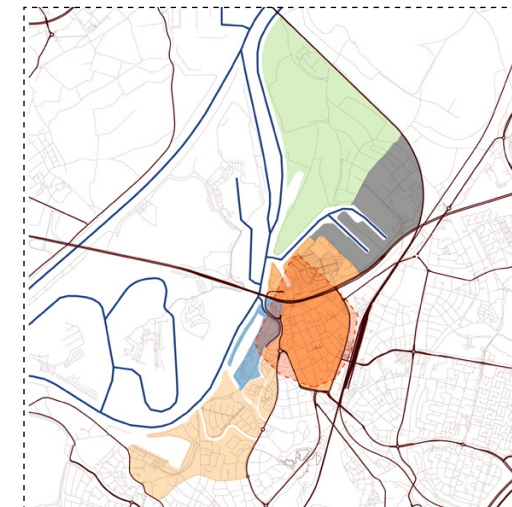

Roermond

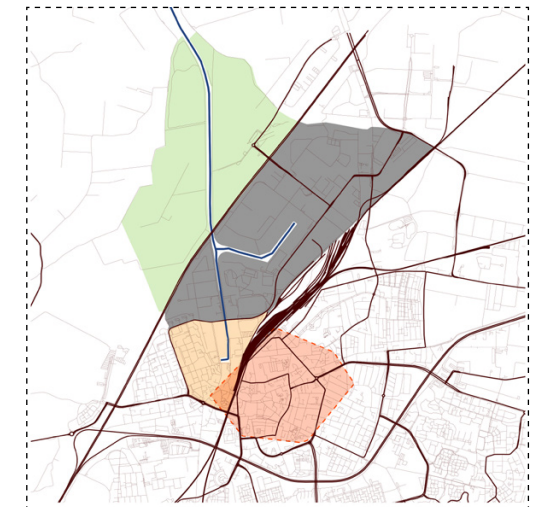

Roosendaal

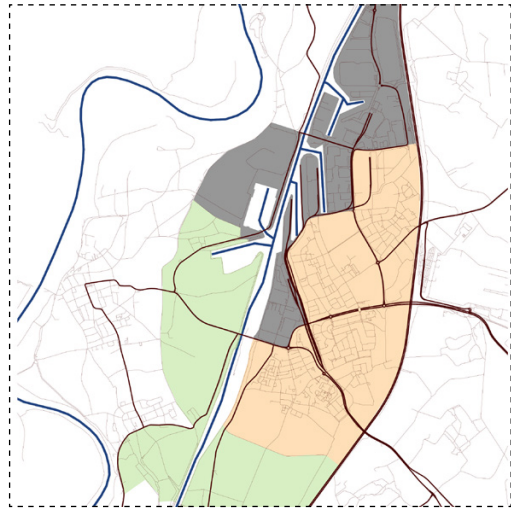

Sittard-Geleen

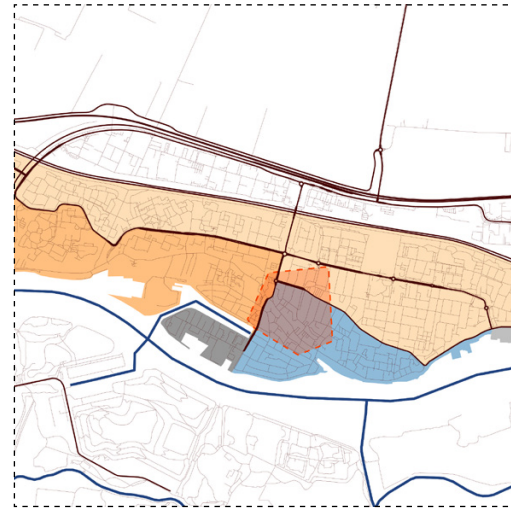

Sliedrecht

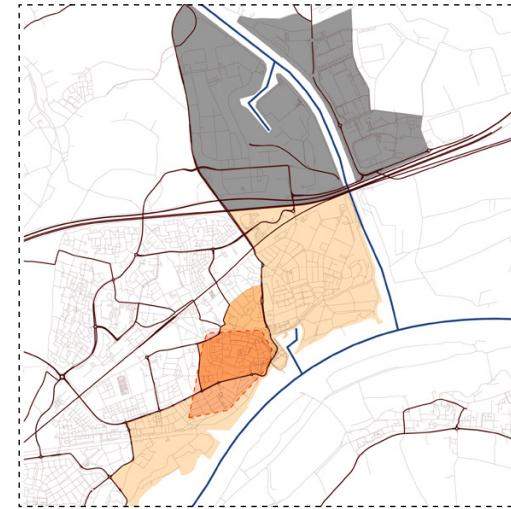

Tiel

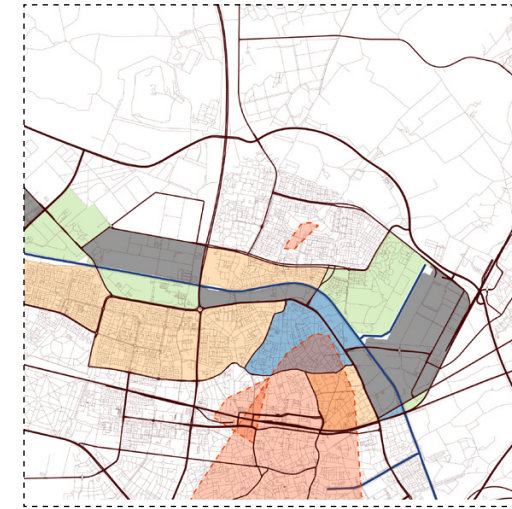

Tilburg

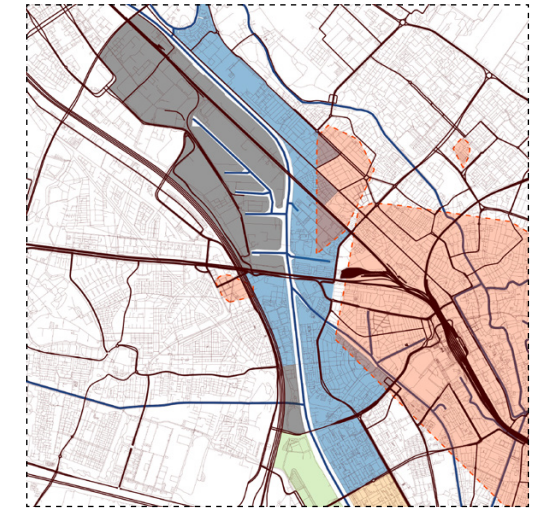

Utrecht



Venlo

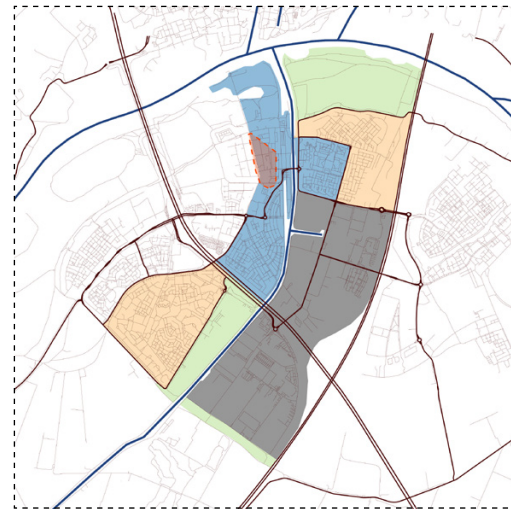

Vijfheerenlanden



Waalwijk

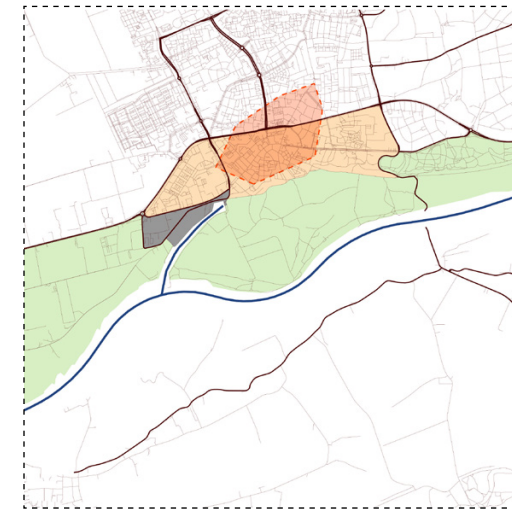

Wageningen



Zwijndrecht

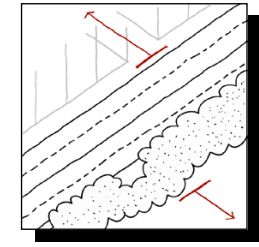
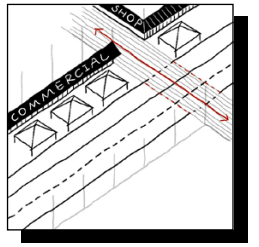
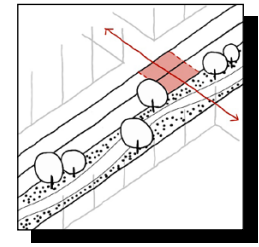
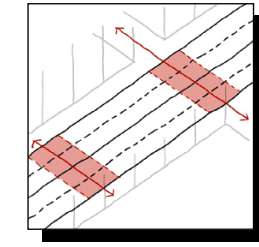
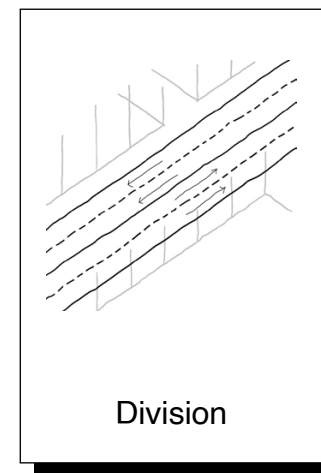
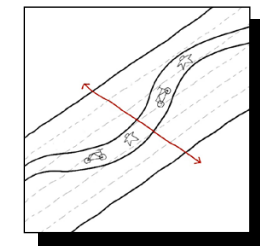
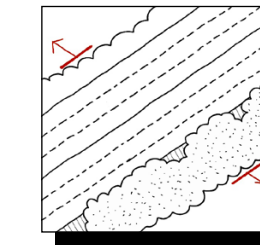
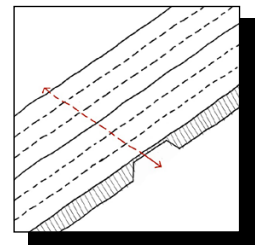
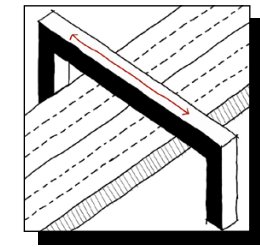
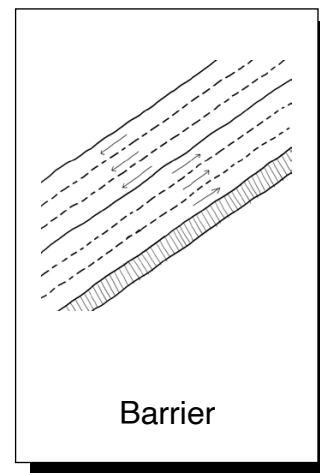
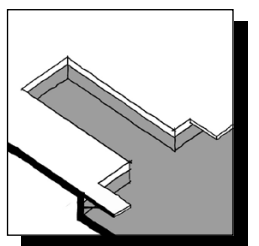
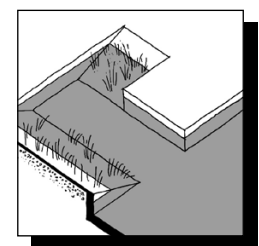
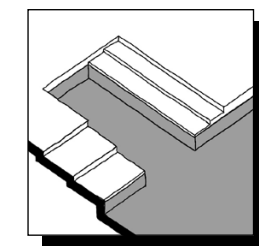
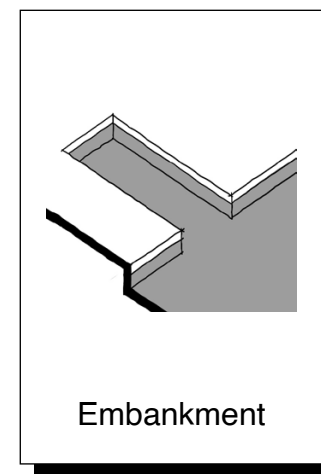
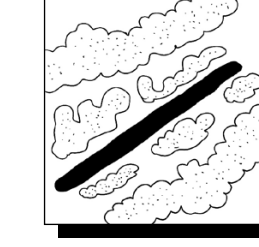
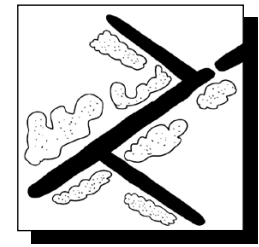
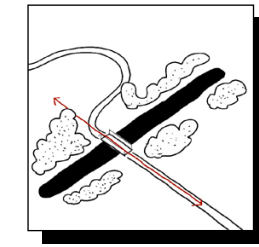
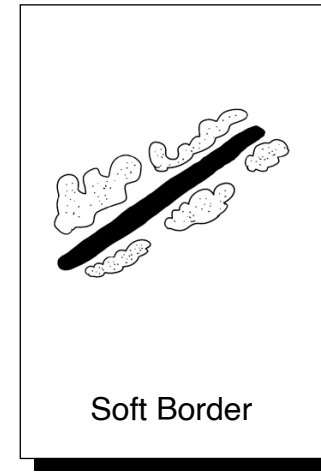

Transformation Potential from IIPC Development Model



Fig. 52, Conclusions from IIPC development model for the case in Tilburg

Transformation Potential from Urban Morphological Imbalances

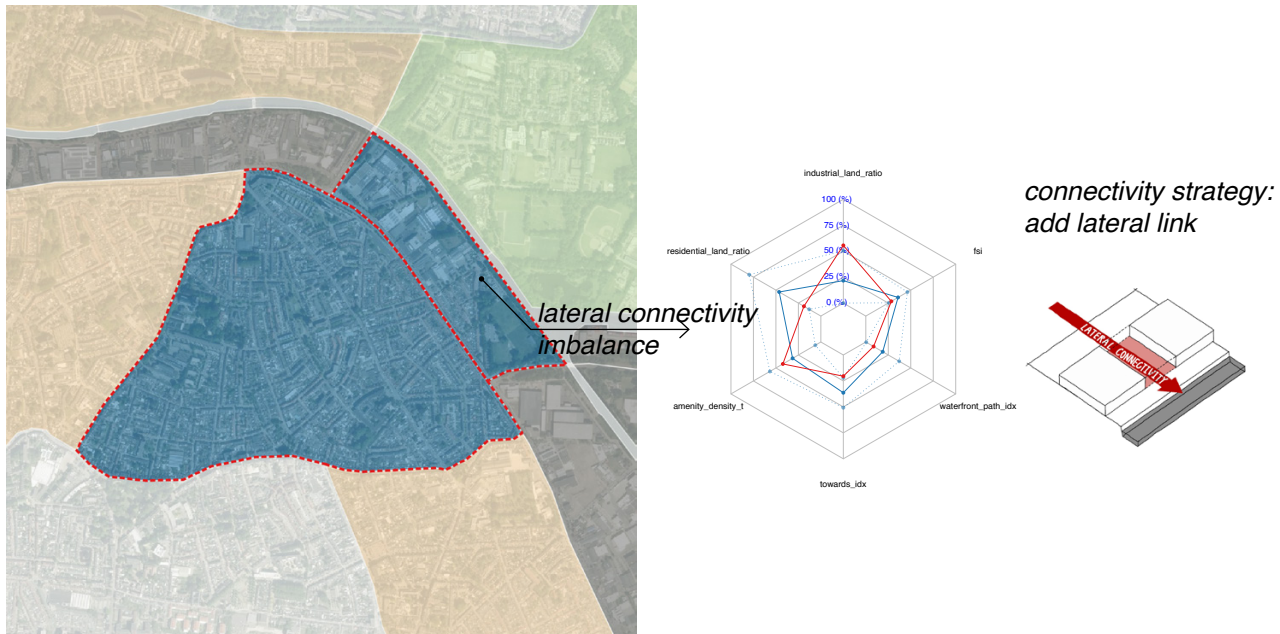
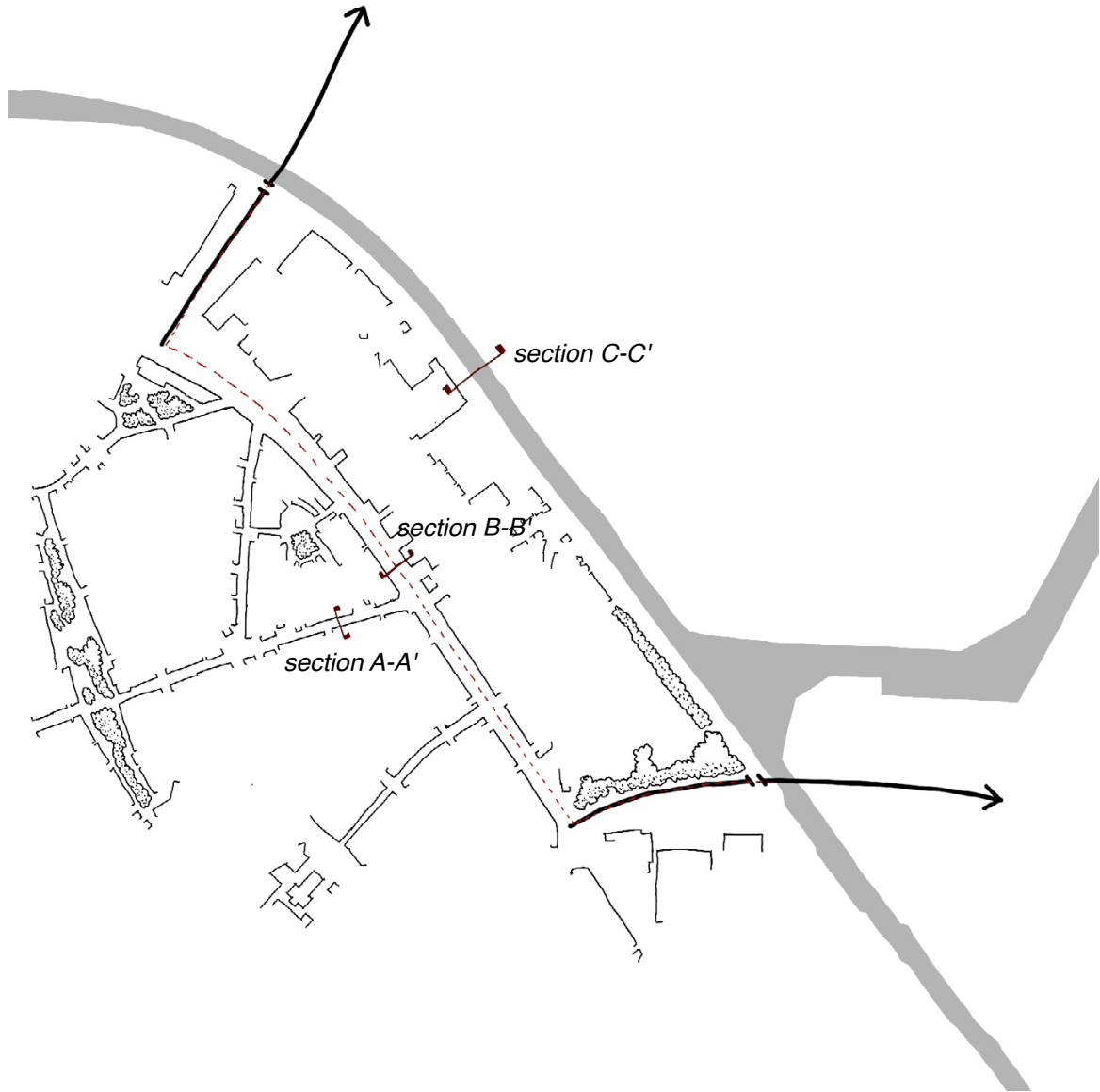

Fig. 53, Conclusions from urban morphological imbalances for the case in Tilburg





section A-A'



section B-B'



section C-C'

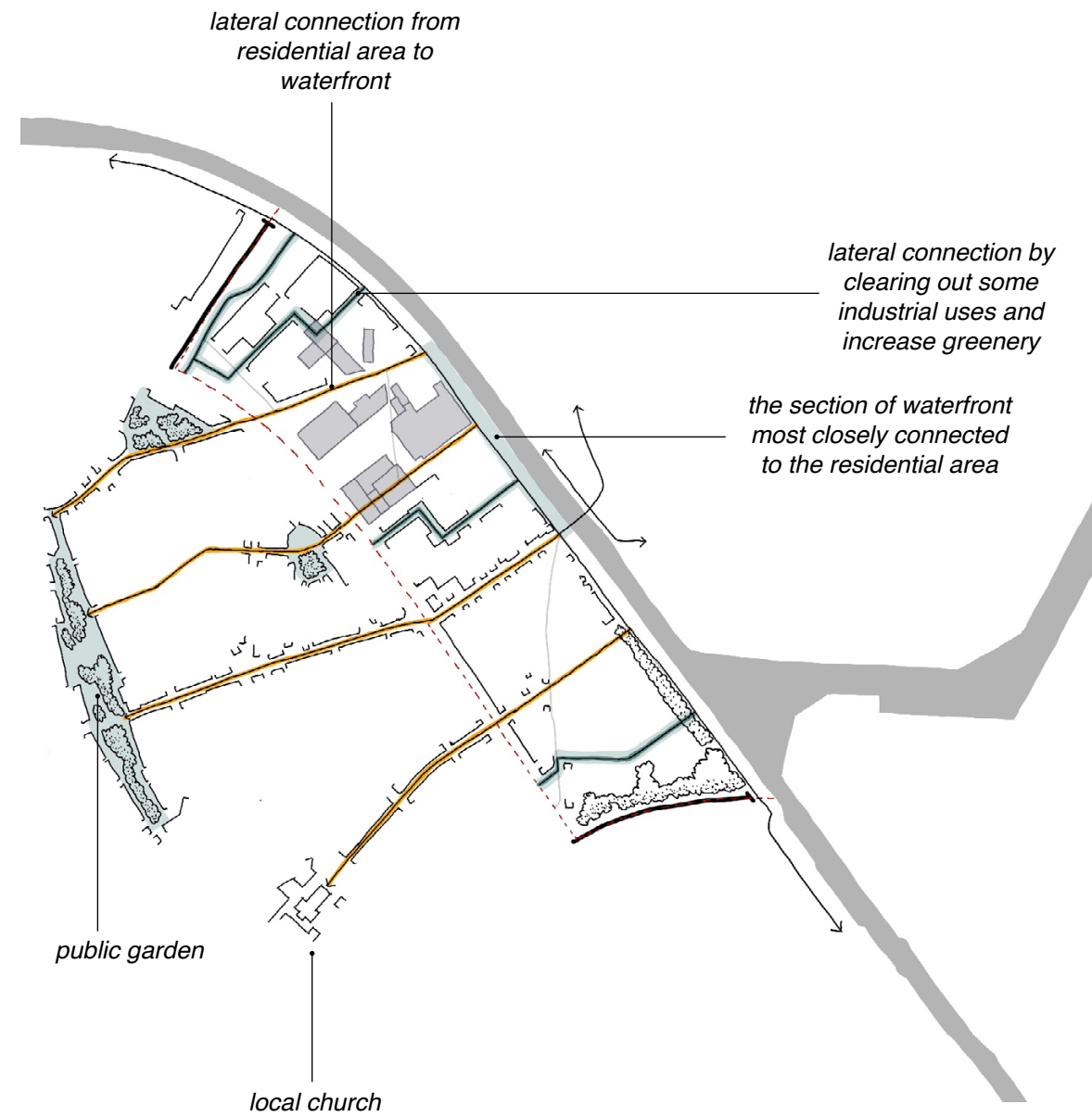

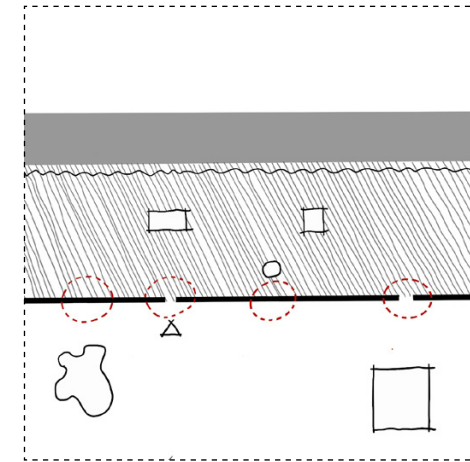
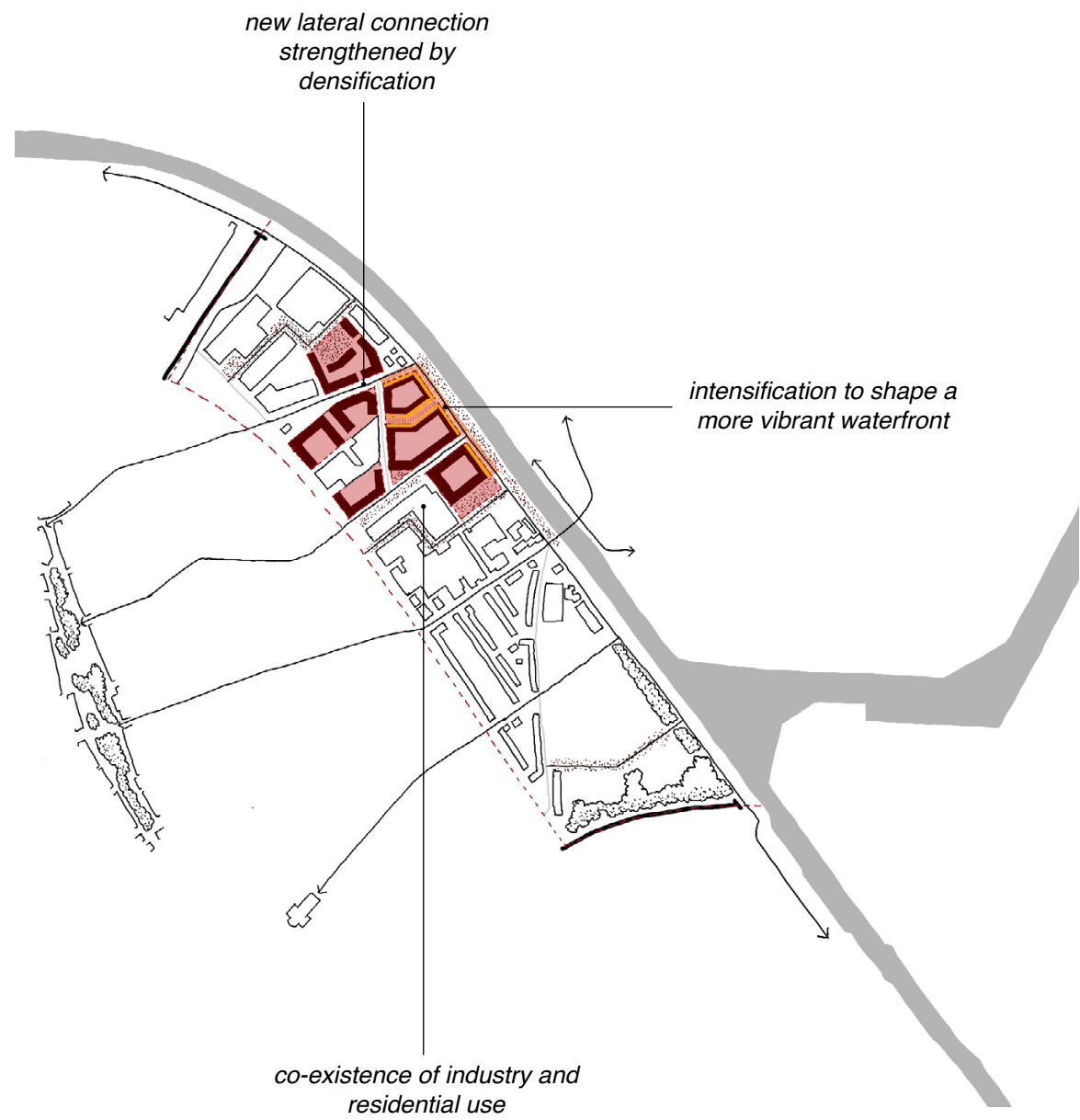

Identify the possible nodes for connection and the urban resources that can be linked to the new connection

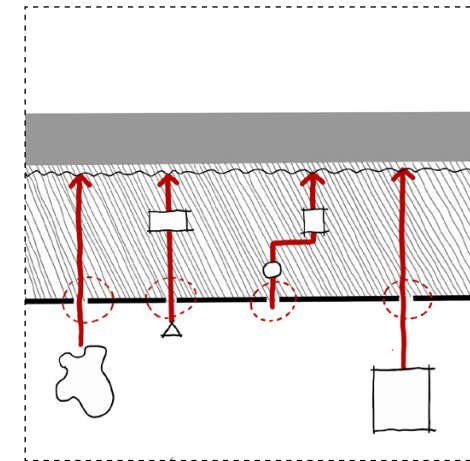

Make the connection and link the identified urban resources

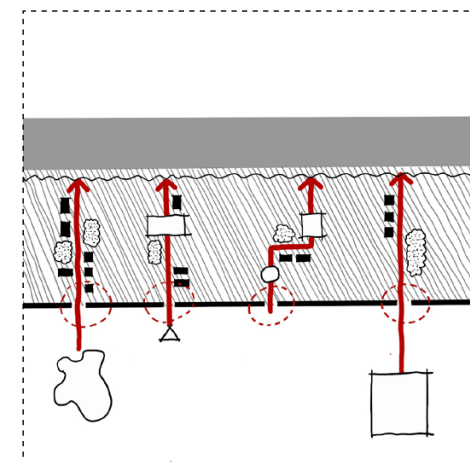

Strengthen the connection by adding more public spaces or densifying to boost vibrant urban activities



Alblasterdam

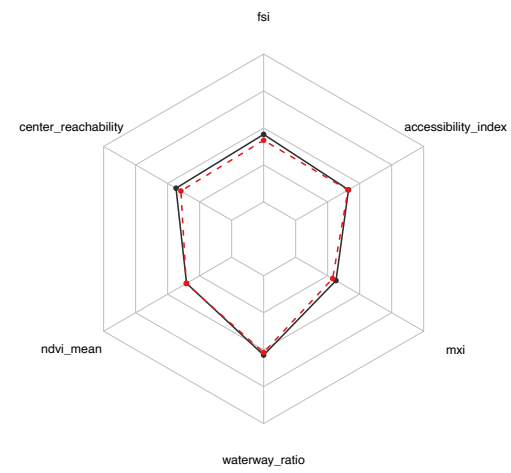

Venlo

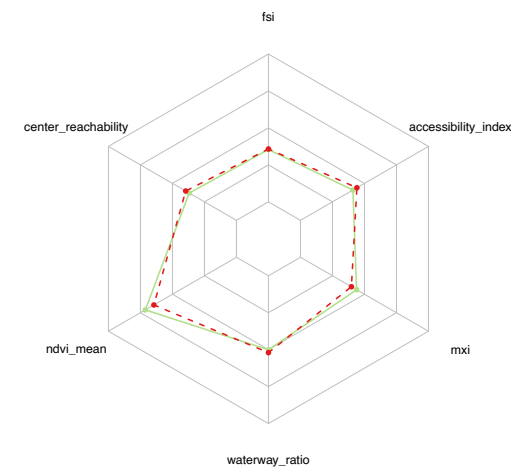

Vijfheerenlanden

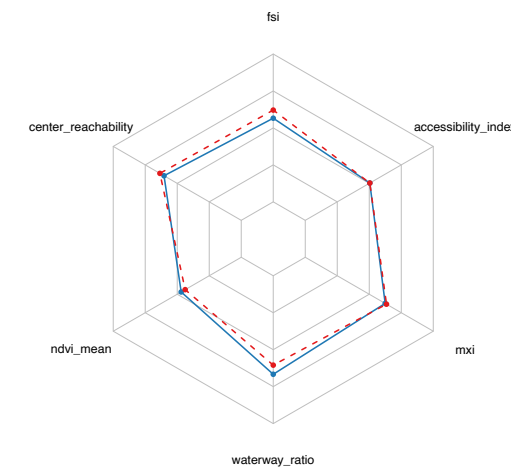

Breda

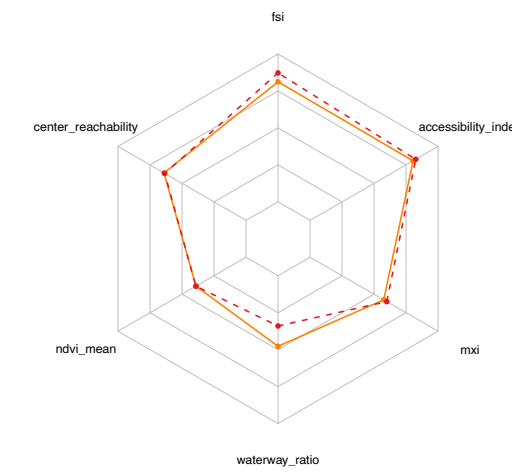

Ridderkerk

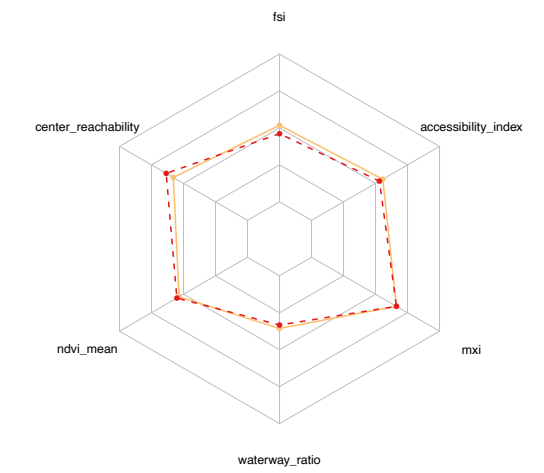

Transformation Potential from IIPC Development Model

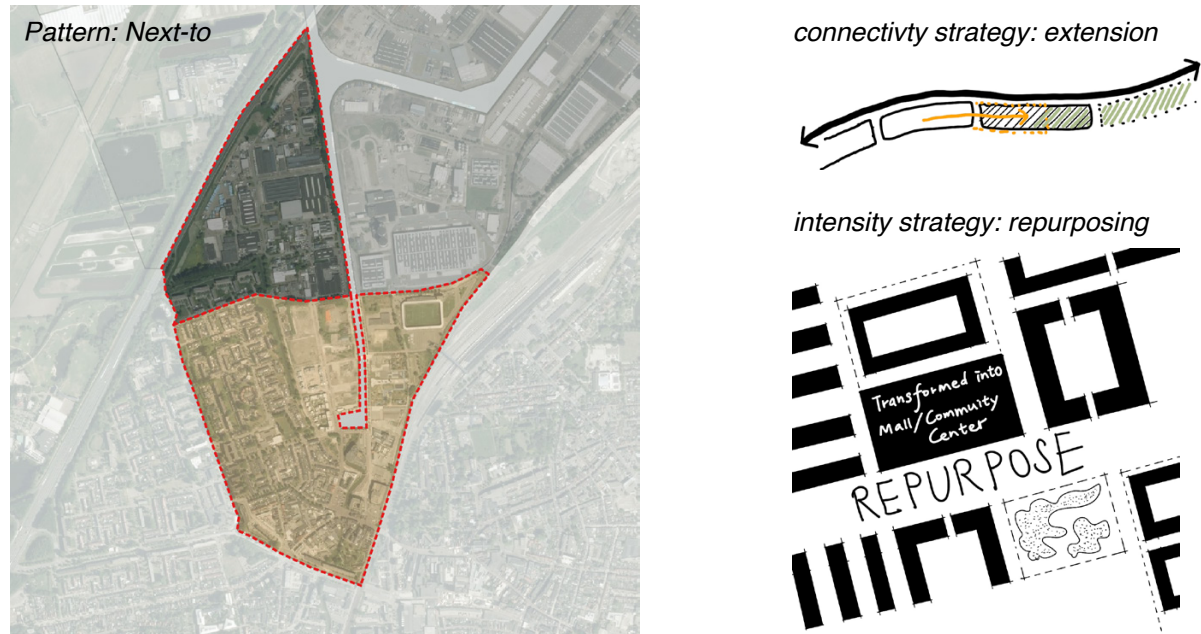
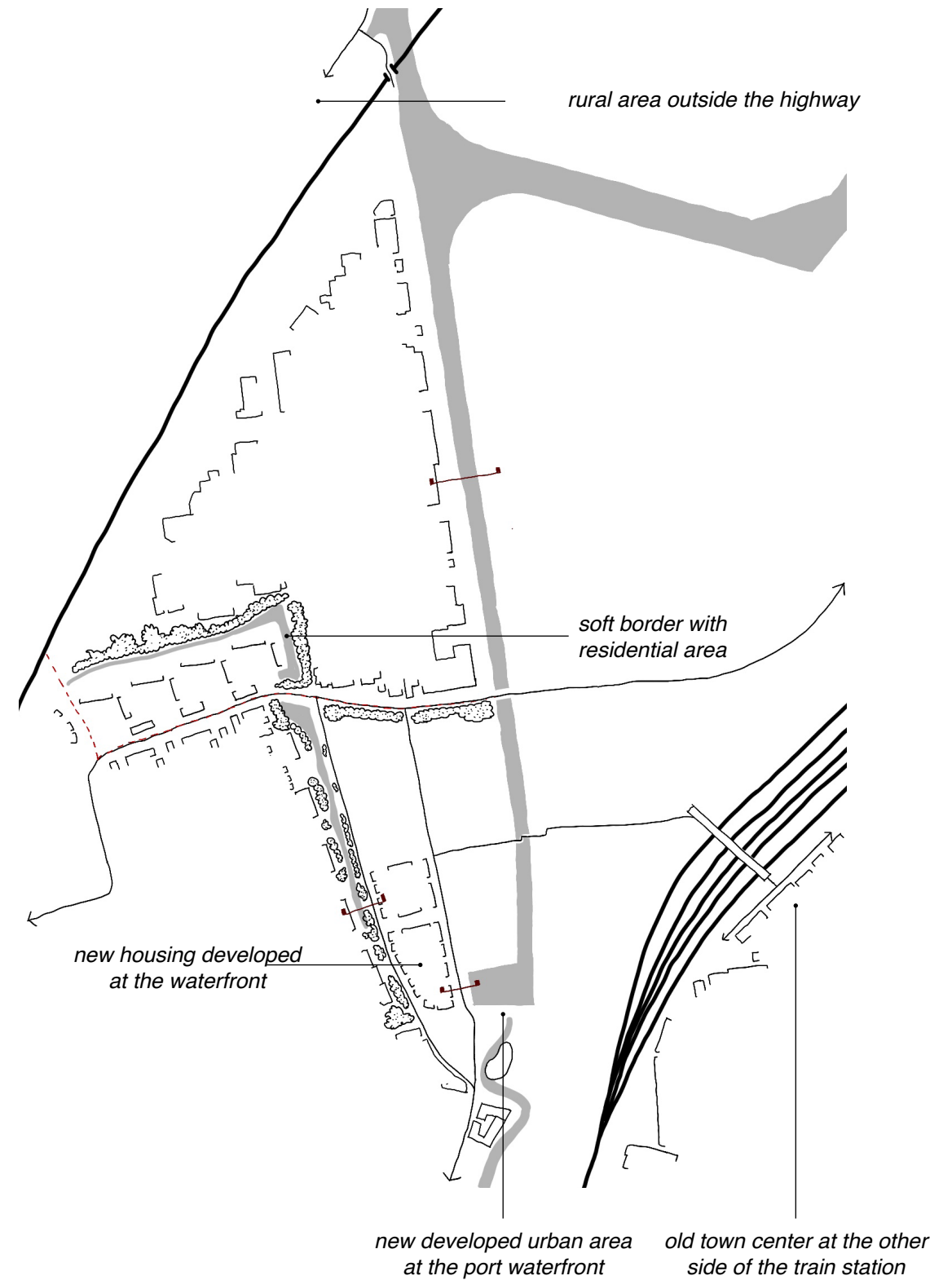
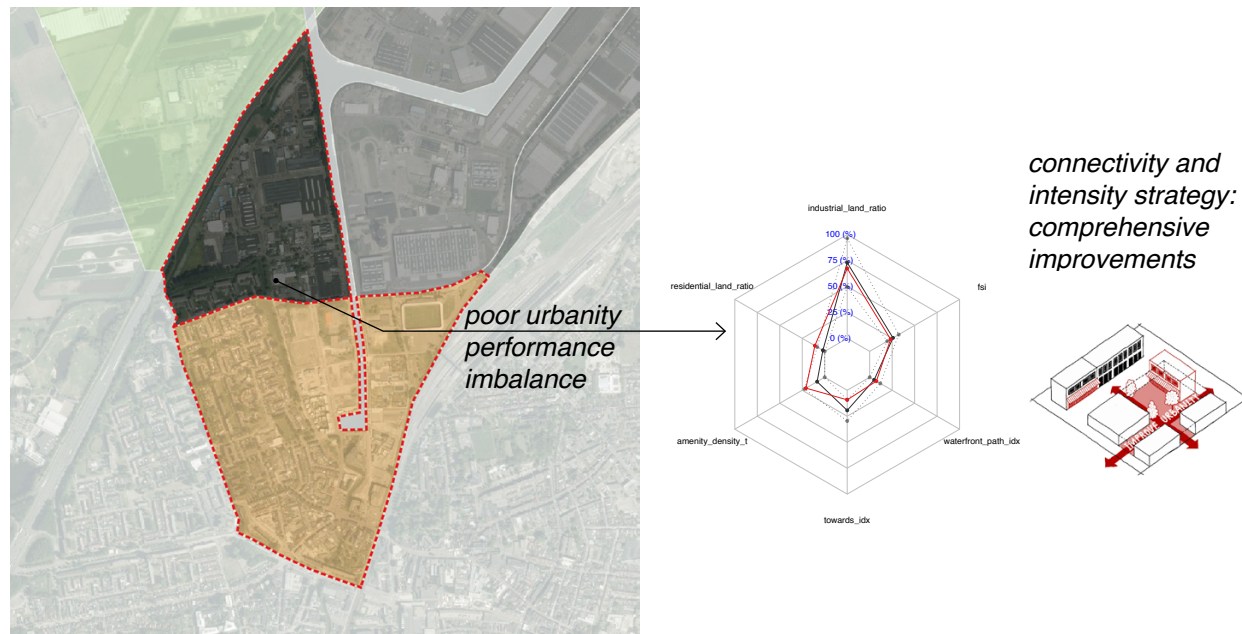
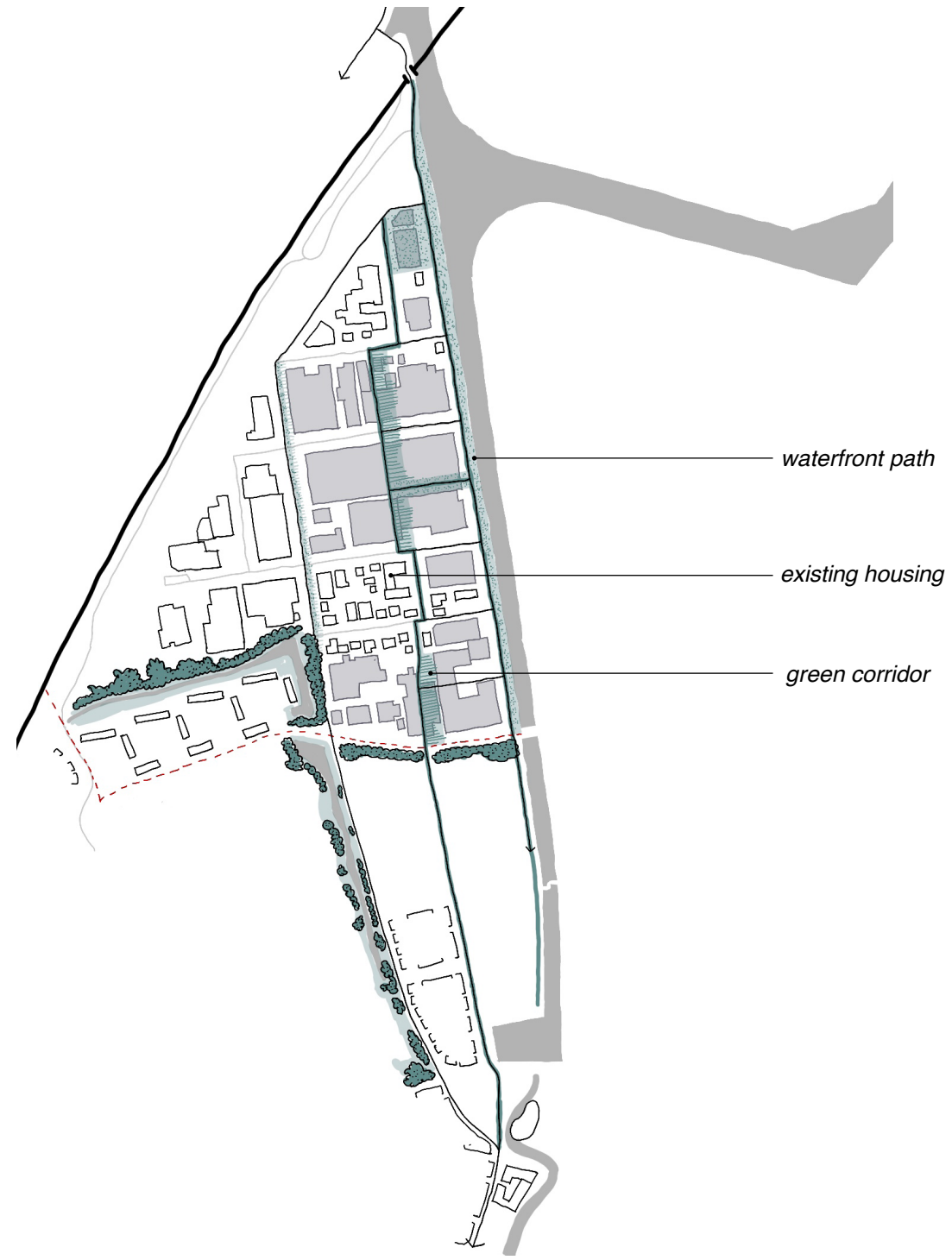
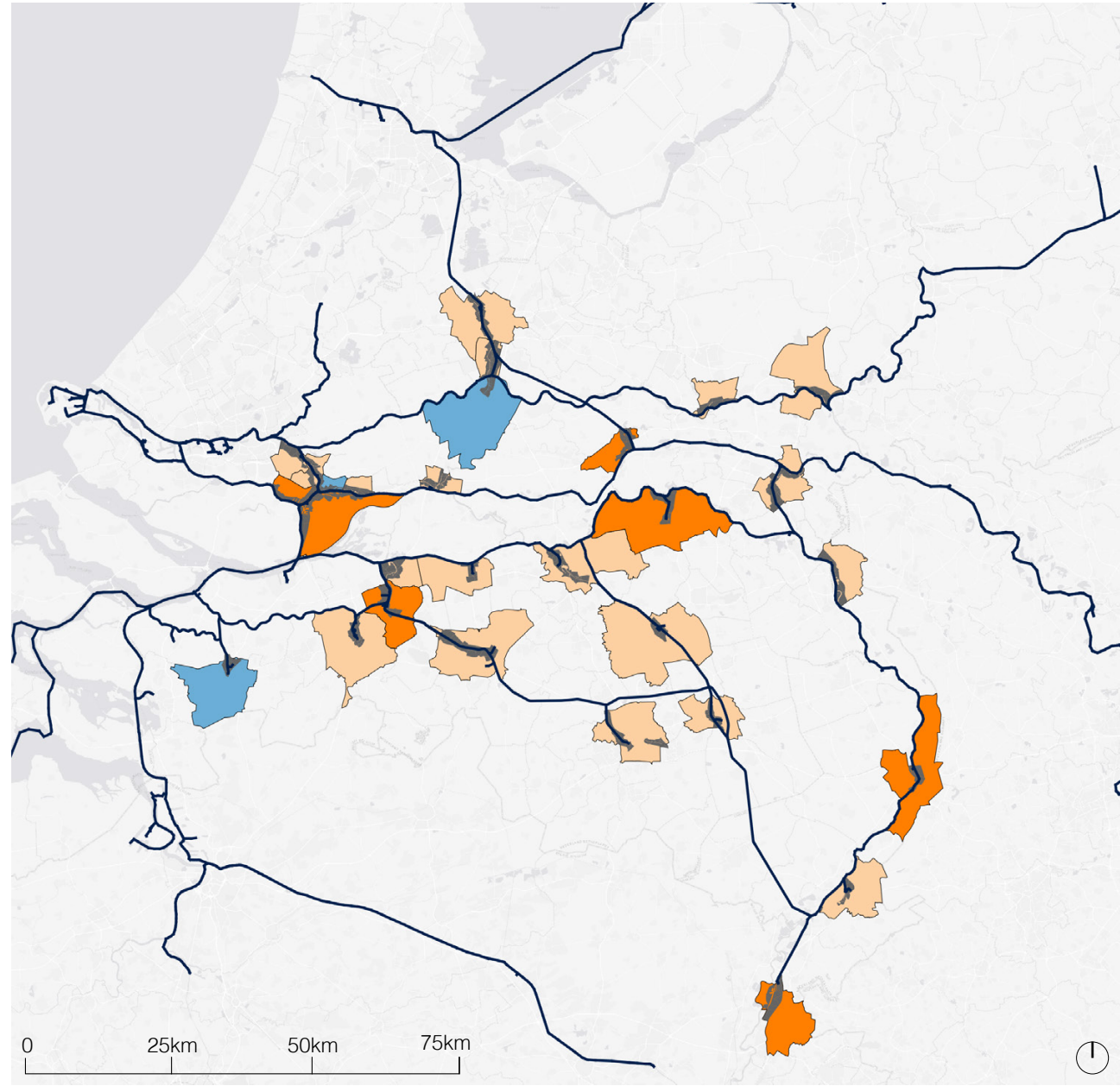

Fig. 60, Conclusions from IIPC development model for the case in Roosendaal

Transformation Potential from Urban Morphological Imbalances







Legend
■ expansion ■ consolidaton ■ shrinkage ■ corridor — waterway

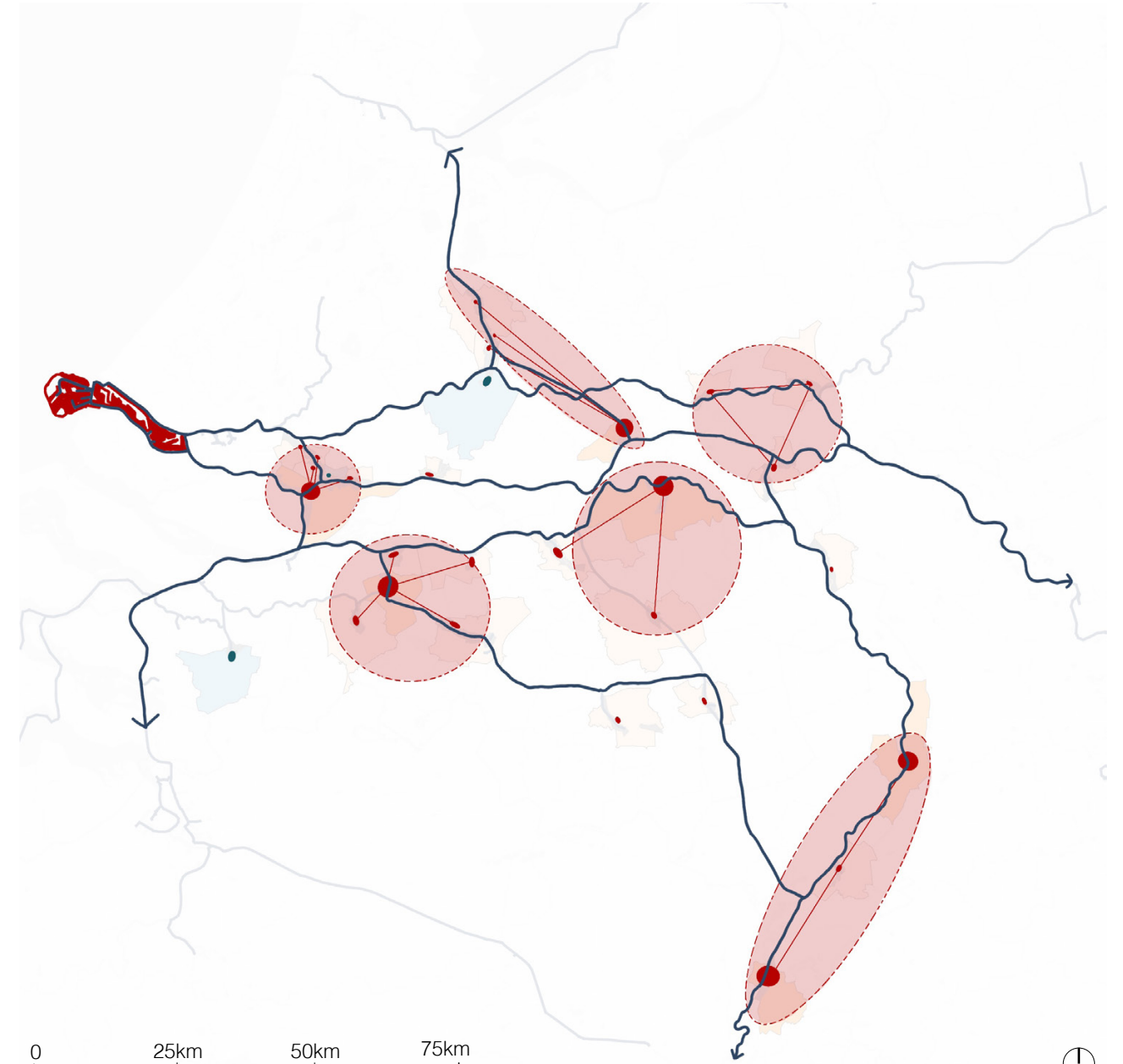

Legend
● expansion IIPC ● consolidation IIPC ● shrinkage IIPC future clusters of neighboring ports
— major waterway corridor

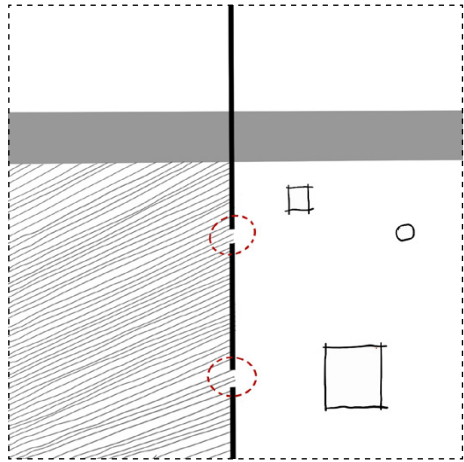

Identify the possible nodes for connection and the urban resources that can be linked to the new connection

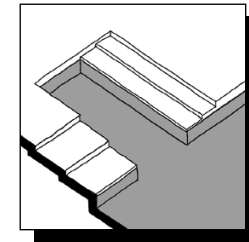
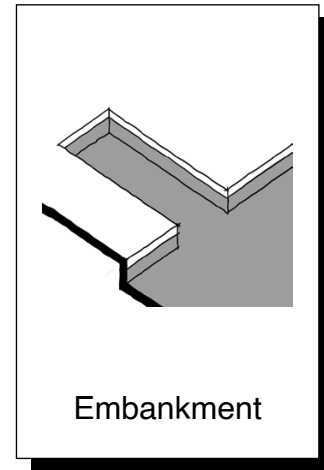

public staircase

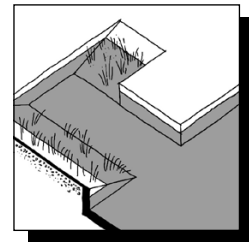

tidal park

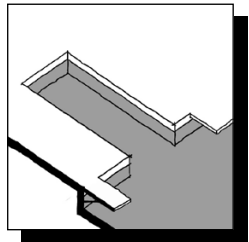

deck

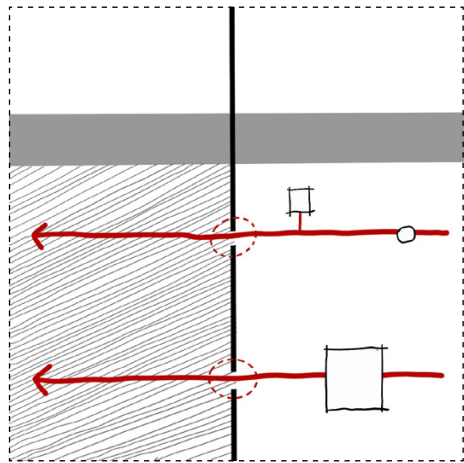

Make the connection and link the identified urban resources

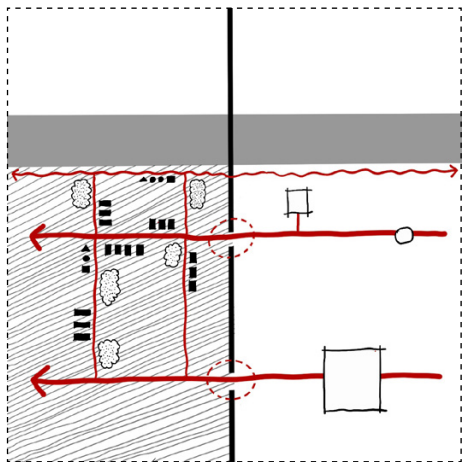
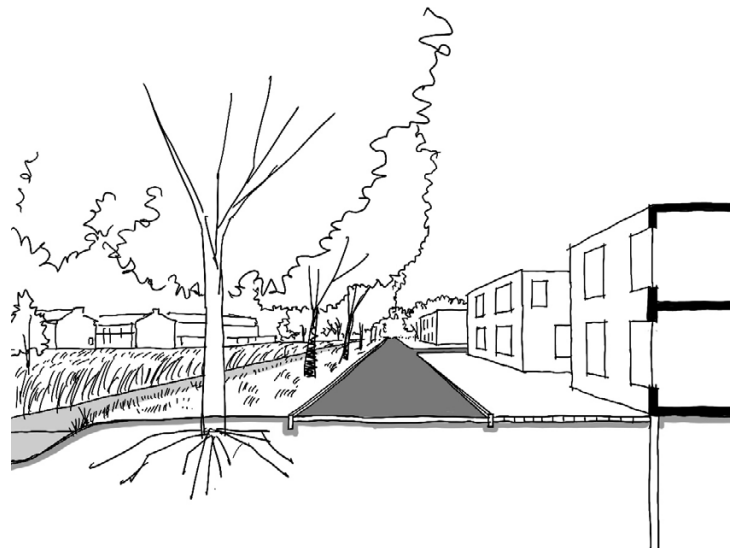

Strengthen the connection by adding more public spaces or densifying to boost vibrant urban activities



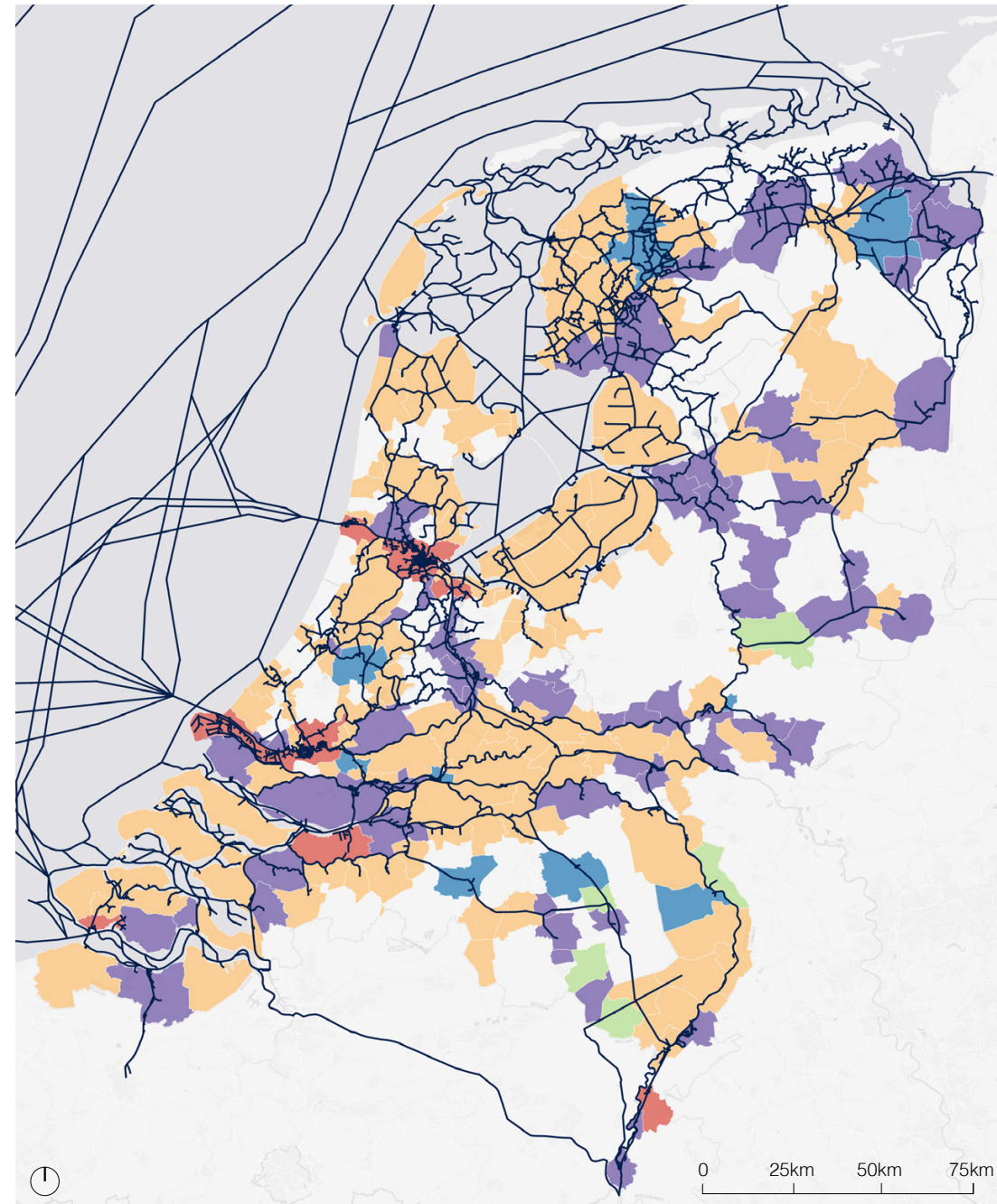

Legend

- chemical industry port
- container port
- large multifunctional port
- sand/gravel port
- agriculture port
- transportation waterway

Source: CBS

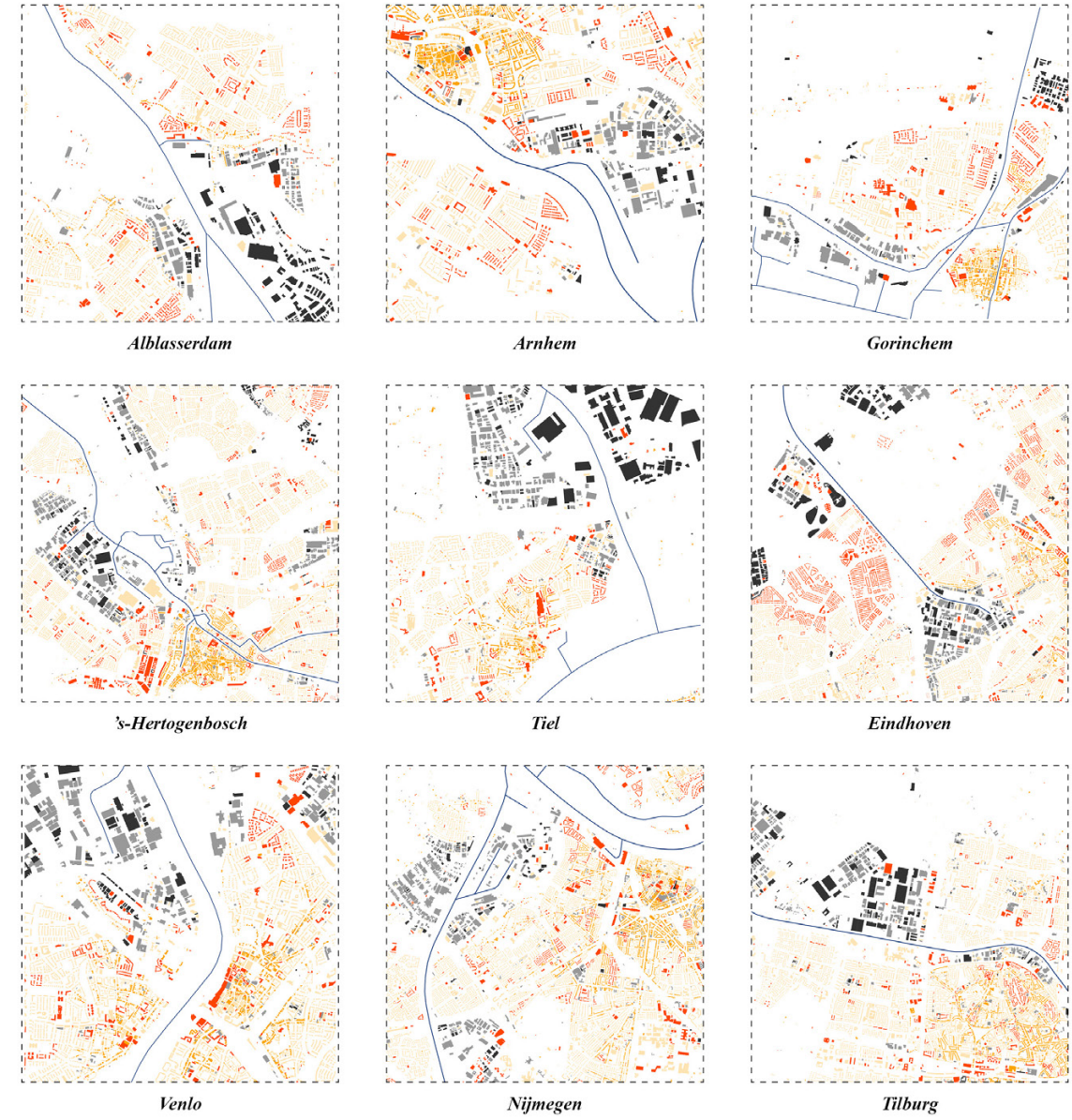

Legend

- waterway
- residential before 1930
- residential 1930-2000
- industry before 2000
- industry after 2000
- residential after 2000

Data source: PDOK



Legend

- border of municipality
- 500m buffer zone around waterway
- corridor delineation

- segment delineation
- waterway
- major infrastructure

Separation

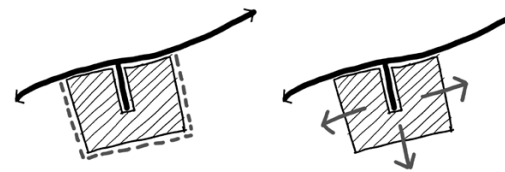
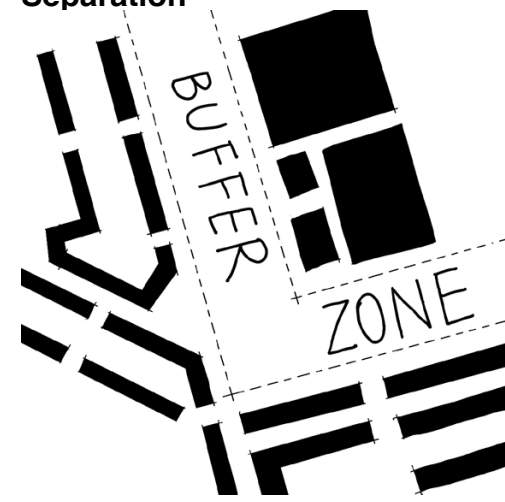

Co-existence

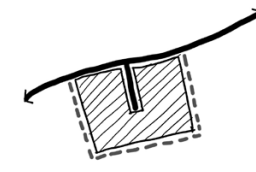

Repurposing

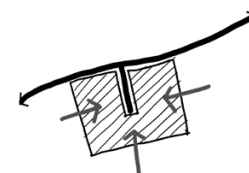

Analysis Results

Identifying Transformation Potential from Urban Morphological Imbalances — — Urban Performance Imbalances Assessment

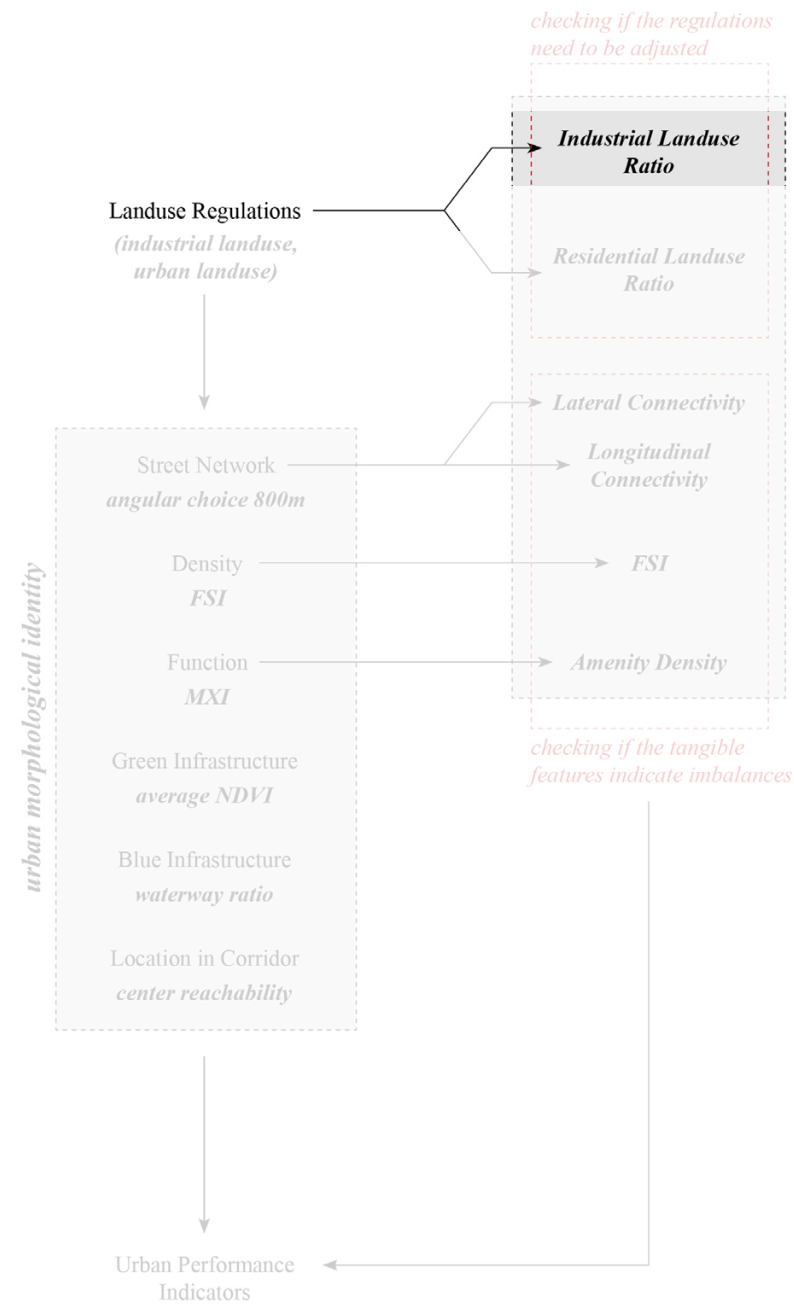

Industrial Landuse Imbalance

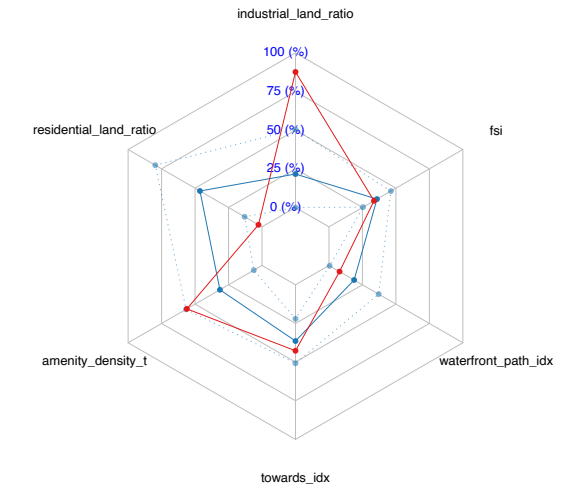

Analysis Results

Identifying Transformation Potential from Urban Morphological Imbalances — — Urban Performance Imbalances Assessment

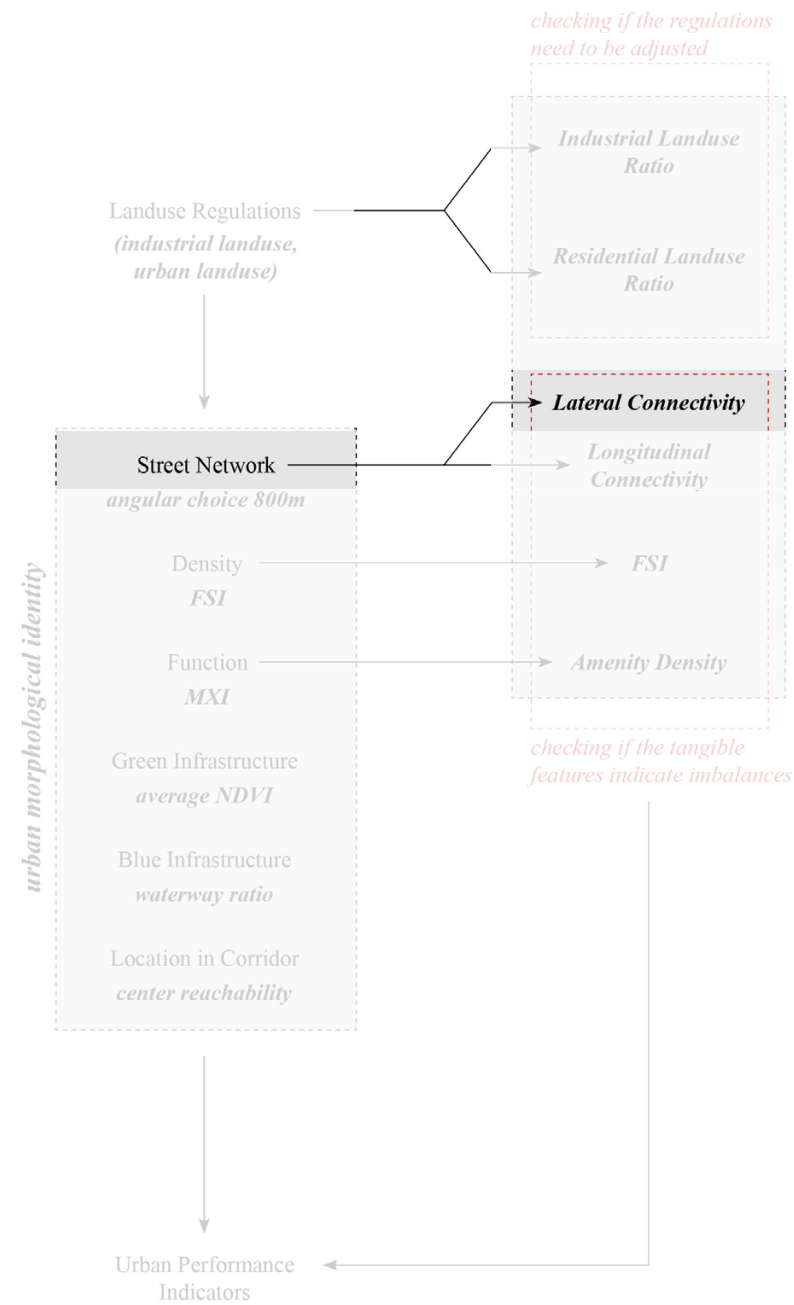

Lateral Connectivity Imbalance

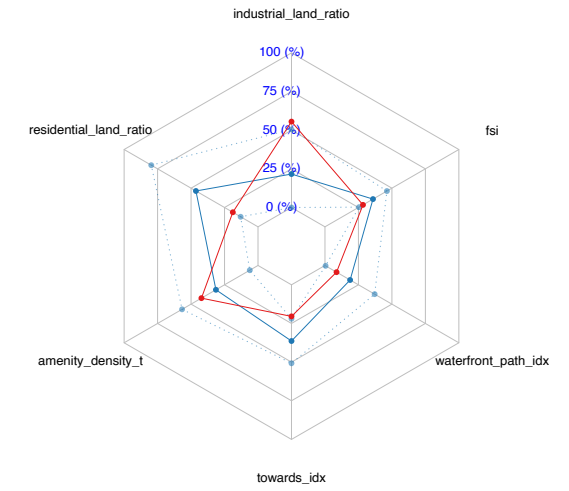

Analysis Results

Identifying Transformation Potential from Urban Morphological Imbalances — — Urban Performance Imbalances Assessment

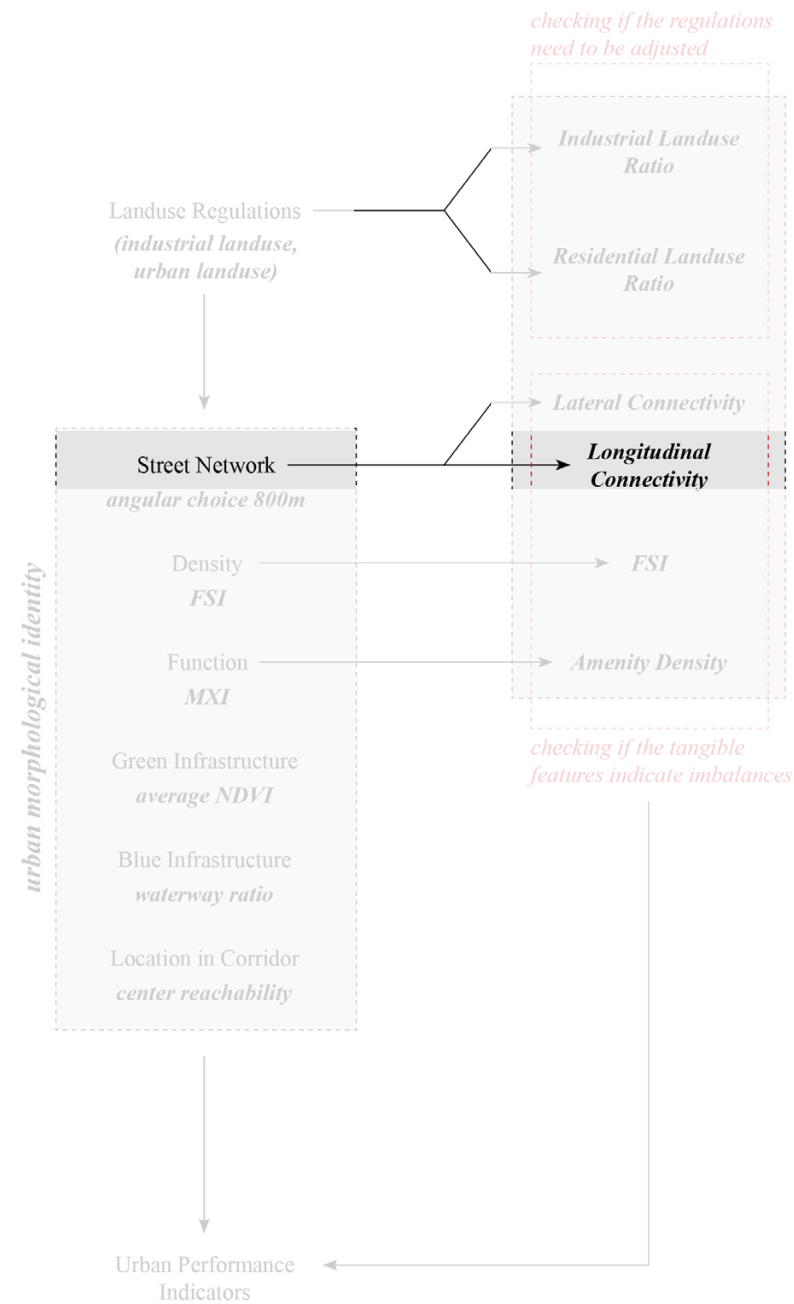

Longitudinal Connectivity Imbalance

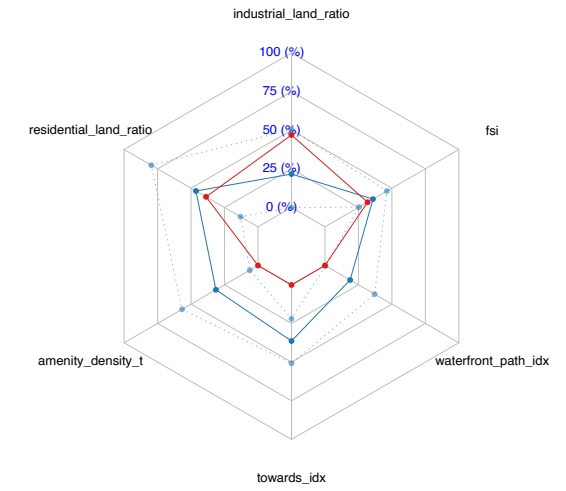

Analysis Results

Identifying Transformation Potential from Urban Morphological Imbalances — — Urban Performance Imbalances Assessment

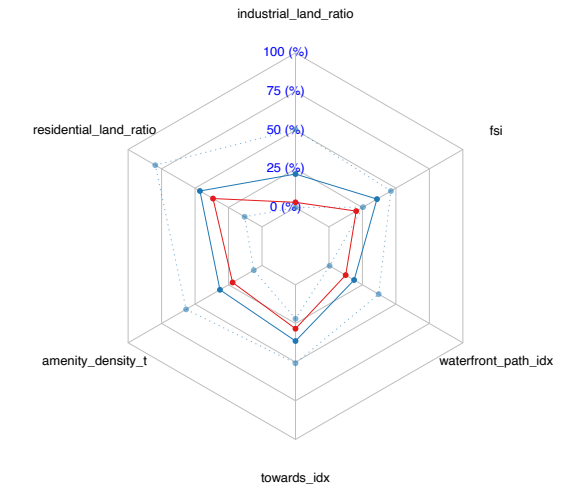
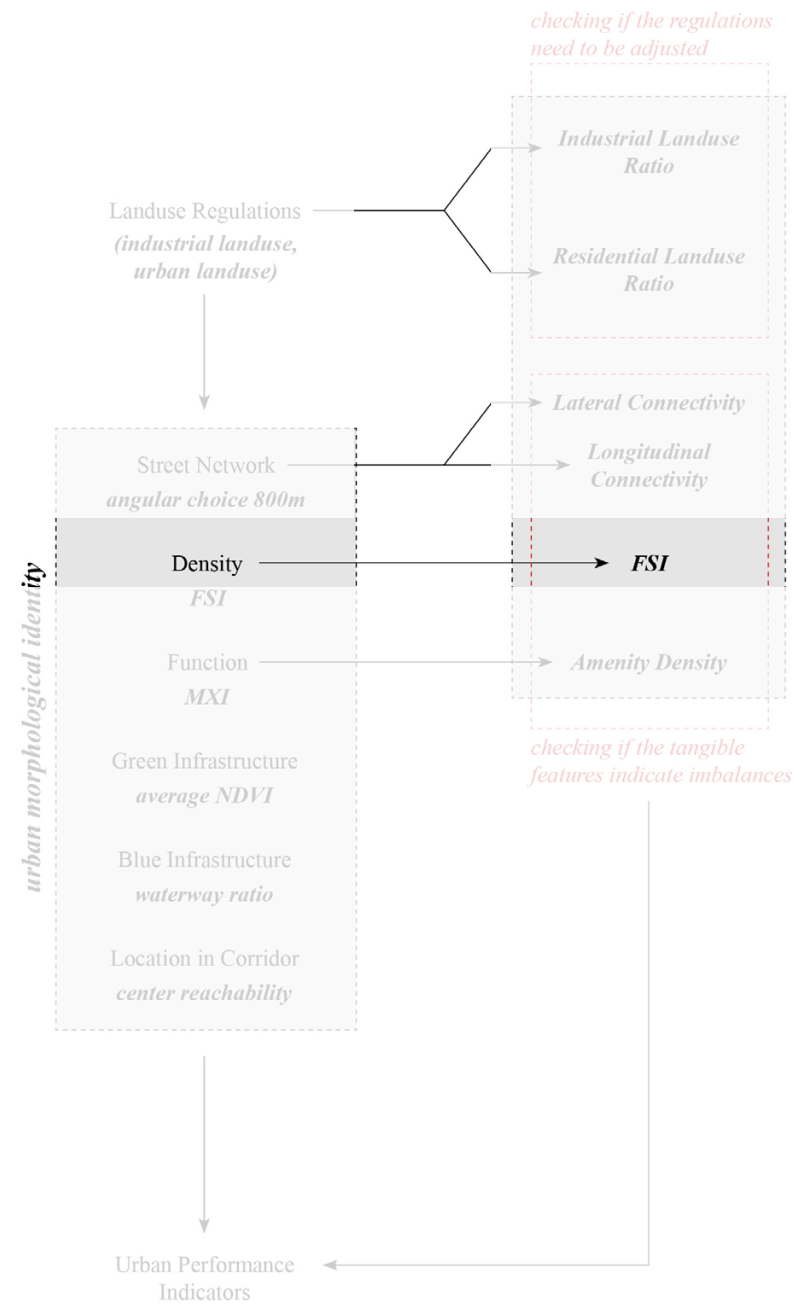

Analysis Results

Identifying Transformation Potential from Urban Morphological Imbalances — — Urban Performance Imbalances Assessment

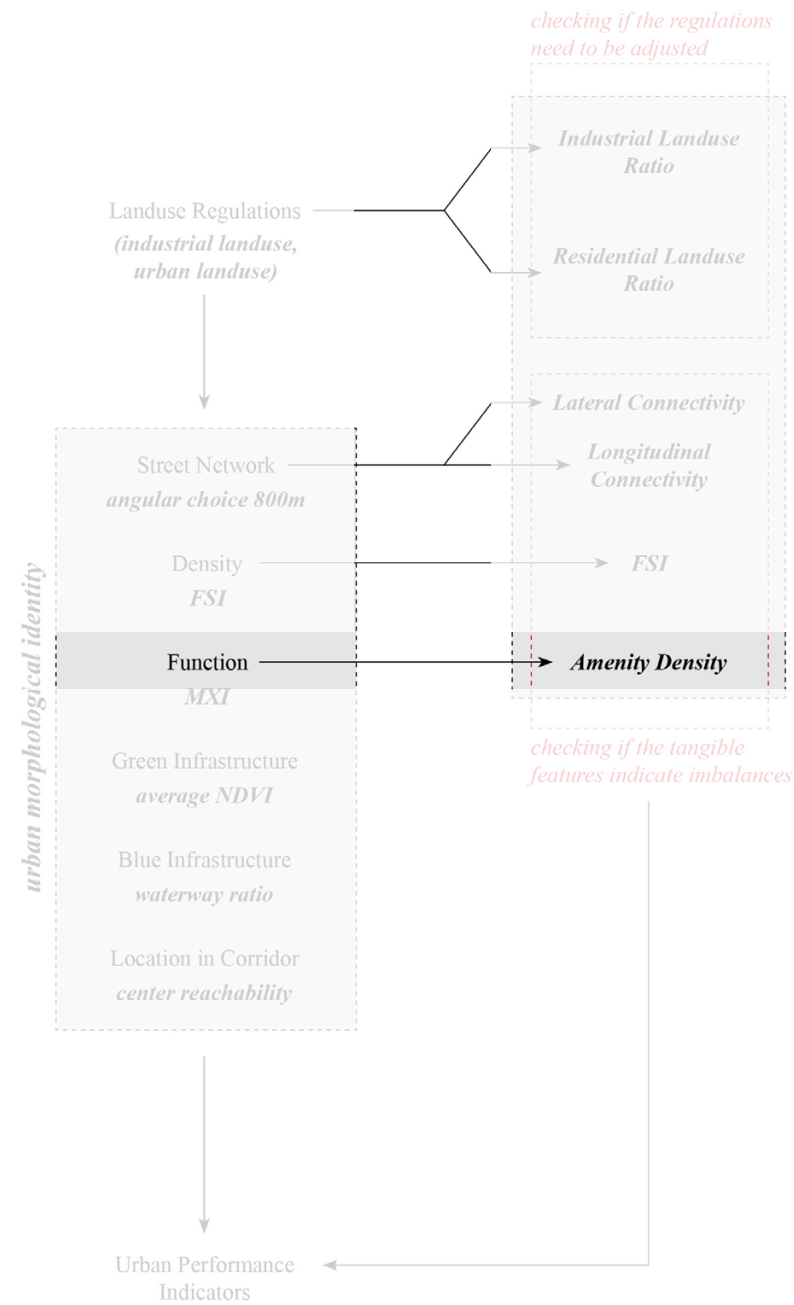

Amenity Density Imbalance

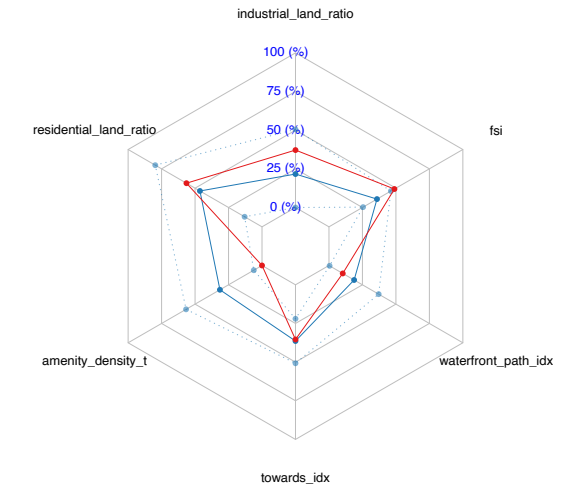

Analysis Results

Identifying Transformation Potential from Urban Morphological Imbalances — — Urban Performance Imbalances Assessment

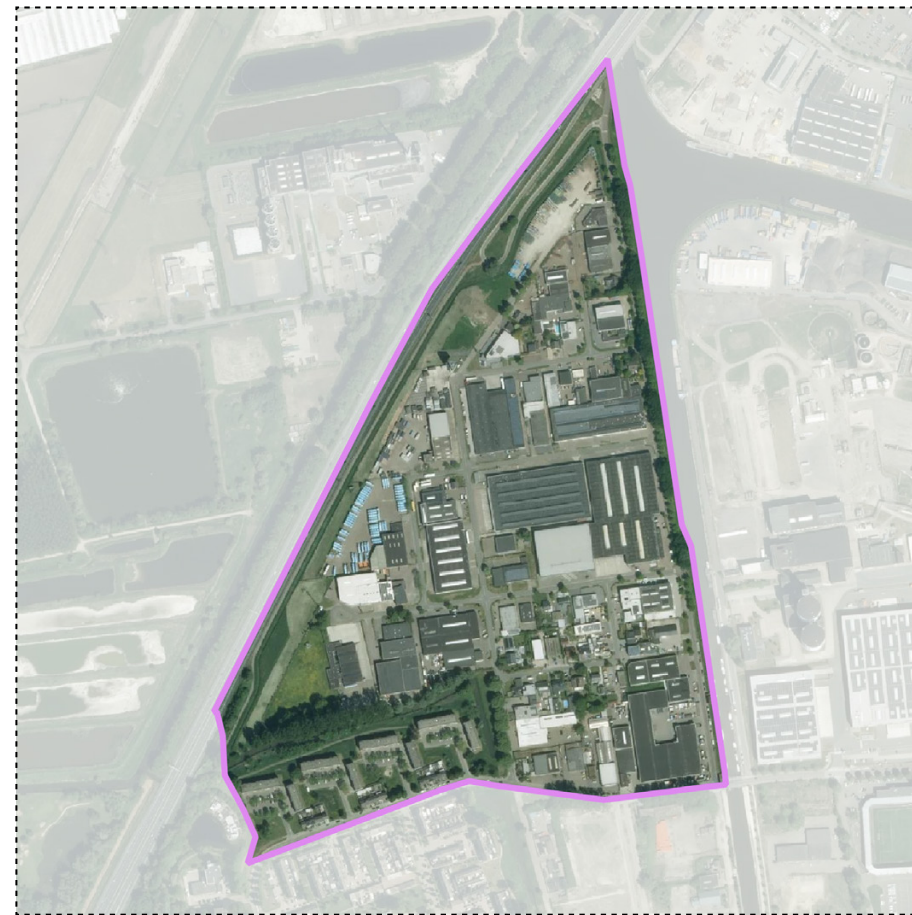
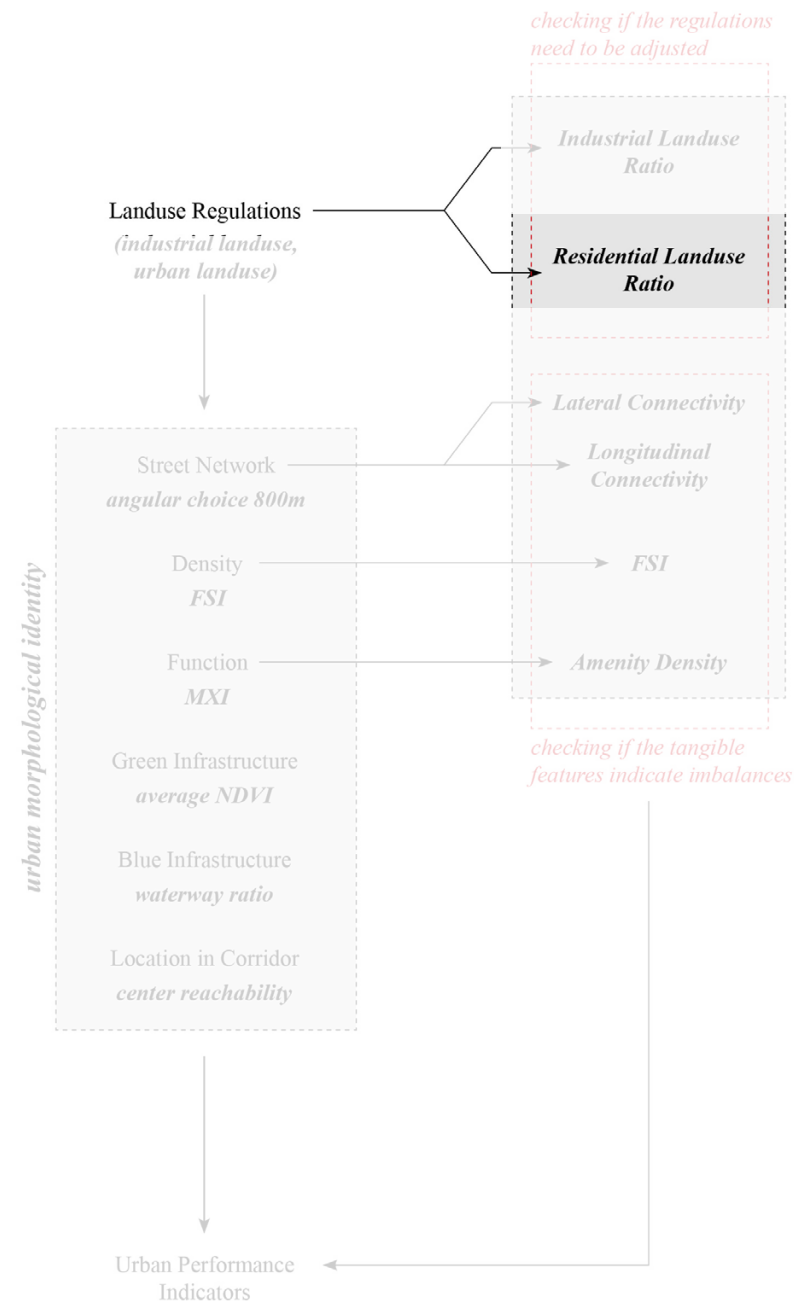

Poor Urban Performance for Residential Area

