

DWELLING WITHIN THE NEW HISTORY

MSC 3 GRADUATION STUDIO 'AT HOME IN THE CITY' | RESEARCH THEME | DUMMY 2012

G. VAN DER HARG	#1502727
V. PETRAK	#1340220
M. VAN VOSKUIJLEN	#4109589

OVERVIEW

Preface	5
Introduction	6
Research question	9
Method	13
Typologies	19
Tools	33
Case studies	35
Courtyard buildings	37
Warehouses	83
Cylindrical buildings	127
Offices	163
Conclusion	187
Reference list	190

***“We attain to dwelling, so it seems,
only by means of building. ... To build
is in itself already to dwell.”***

- Martin Heidegger -
(Heidegger, 1971, pp. 143, 144)

Our graduation studio is about designing dwellings. Since the word dwelling can have different meanings, this research report will start with our definition of this word.

Dwelling is a word with dual expressions. According to Hawkins the verb ‘dwelling’ in the present tense, reveals that there is a history. The dweller has explored, discovered and now has settled. It means a continuation of a life time experience. A dwelling gives also constancy. *“A person who truly dwells is a person who has found peace. Thus dwelling becomes a deeply internalized sense of purpose and meaning, a way of life. To dwell is to abide, to reside, to remain”* (Hawkins, 2010, p. 4).

Even the noun ‘dwelling’ has awareness of time, *“simultaneously represents the legacies of former residents, the routines of its current inhabitants, and the dreams and aspirations of future dwellers”* (Hawkins, 2010, p. 4).

Our definition of dwelling contains a history, a present and a future part. Our research will therefore focus on historical buildings with a current function as dwelling in order to apply characteristics of these dwellings in new buildings in the future.

Goedkoop huis in verramsjt kantoor

Groot nieuws: kantoorruimte wordt voor ramsjprizen van de hand gedaan! Daardoor wordt het mogelijk voor starters op de woningmarkt goedkoop veel ruimte te kopen en zelf te verbouwen.

MICHIEL MULDER

Deze week kwamen er enkele opvallende berichten uit de vastgoedsector, die verstrekende gevolgen hebben voor de stedelijke ontwikkeling in Amsterdam. Een aantal vastgoedfondsen kan niet meer aan zijn verplichtingen voldoen en een groot deel van de investeerders ziet zijn geld niet terug. Hierdoor komen kantoren tegen bodemprijzen op de markt.

Dit biedt kansen voor ombouw naar woningen, hotels, voorzieningen. Jaren gebeurde dit niet of mondjesmaat, omdat beleggers wachtten op de gouden huurder en het pand liever tegen hoge boekwaardes – vaak meer dan 1500 euro per vierkante meter – op de balans leeg lieten staan, zodat men zijn verlies niet hoefde te nemen.

In heel Nederland is de leegstand van kantoren sinds de eeuwwisseling verviervoudigd en in Amsterdam staat 1,3 miljoen vierkante meter kantoorruimte leeg. Vastgoedfondsen zijn de grootste partij in het bedrijfsvastgoed, met veel leegstand. In Amsterdam gaat het om gebieden rond Sloterdijk en Amstel III in Zuidoost.

Wat is er nu gebeurd? De vastgoedportefeuille van Uni-Invest, met 1,2 miljoen vierkante meter kantoor- en bedrijfspanden, is voor 360 miljoen euro verkocht aan Britse en Amerikaanse durfkapitalisten (Patron Capital en TPG). Omgerekend is dit 300 euro per vierkante meter, niet veel meer dan de oudbetonprijs. De investeerders hebben plannen gepresenteerd om

een deel van hun leegstaand vastgoed tegen zeer lage huren aan te bieden en een ander deel te transformeren naar hotels en studentenwoningen. Zij hebben hiermee ervaring in het buitenland. Een vijfde deel van het bezit willen zij verkopen 'tegen grondwaarde'. Hier wordt dus volledig afgeschreven op het vastgoed.

Spraken diverse vastgoeddeskundigen na deze deal nog van een uitzonderlijke situatie waar taxateurs weinig mee kunnen, na deze week is dat niet meer vol te houden. 112.000 vierkante meter Nederlandse kantoren en bedrijfsgebouwen uit de portefeuille van EPI Orange, dat onder beheer staat

Met 100 m² voor maar 50.000 euro kun je nog flink verbouwen

van een Franse bank, werd voor 50 miljoen euro verkocht aan een onbekende durfkapitalist, werd deze week bekend. Dit is een afwaardering van 33 procent ten opzichte van de taxatiewaarde van nog geen jaar geleden: de verkoopprijs komt nu neer op 450 euro per vierkante meter.

Reken eens mee wat een boekwaarde van minder dan 500 euro per vierkante meter voor mogelijkheden biedt. Amsterdammers op zoek naar woonruimte kunnen dan 100 vierkante meter kopen voor 50.000 euro. Met een modaal inkomen kun je



Een kantoor bij Sloterdijk kan straks een mooie woning worden. FOTO KLAAS FOPMA

door de hypotheekrestricties van banken en het kabinet nauwelijks meer dan 150.000 euro lenen, maar dan heb je nog altijd een ton te besteden om de ruimte te verbouwen en bewoonbaar te maken.

Kunstenaars kunnen al dan niet in collectieven ruimtes in gebruik nemen om te wonen en te werken. Jongeren kan de mogelijkheid geboden worden zelf aan hun woning te klus-

vraag de ouders mee te investeren of garant te staan.

De gemeenteraad van Amsterdam heeft in 2011 ruim baan gegeven om dit type transformatie mogelijk te maken door met de motie-Mulder alle regels te schrappen die wij als gemeente kunnen schrappen. Wet- houder Van Poelgeest zet zijn schouders eronder en de eerste transformaties zijn reeds een feit. Met het dalen van de boekwaardes vervallen ook de financiële hobbels, zodat een aanmerkelijke versnelling mogelijk wordt.

En deze twee vastgoedtransacties zijn nog maar het begin. Er zijn zes vastgoedfondsen met bezit in Amsterdam die op dezelfde wijze gefinancierd zijn als Uni-Invest en EPI Orange. Als zij of andere fondsen tegen dezelfde betalingsproblemen aanlopen, moeten zij ook tegen ramsjprizen verkopen.

Daarnaast zijn er liquiditeitsproblemen bij Duitse vastgoedfondsen, die in totaal voor 6 miljard euro in Nederlands vastgoed hebben geïnvesteerd. SEB ImmoInvest heeft al aangegeven dat liquidatie onvermijdelijk is en meer zullen volgen. Omdat zij moeten verkopen, zullen de hoge waardes waarvoor het vastgoed in de boeken staat niet vol te houden zijn.

Amsterdammers kunnen eindelijk iets positiefs merken van de financiële crisis en de bijbehorende dynamiek op de vastgoedmarkt.

De auteur is woordvoerder ruimtelijke ordening in de gemeenteraad voor de PvdA

Fig. 1 Article about dwelling units in vacant office buildings for bottom prices (Mulder, 2012)

INTRODUCTION

RESEARCH THEME

At this moment, there is in the Netherlands a record on vacant office spaces, which are for sale or for rent, according to ANP. The supply of vacant office space has been increased with 7% during the last one and a half year. The total amount of vacant office spaces in the Netherlands, at this moment is 7.62 million square meter, which is 15,4% of the whole supply of office spaces in the Netherlands (ANP, 2012a).

From real estate brokers' point of view, the only solution for the vacant office spaces is to do nothing. The real estate brokers advise homeowners to decrease the sale prices and rent prices of their property, but homeowners do not want to decrease their prices. This wait-and-see attitude of homeowners leads to a lack of investments in those properties. Only 18% of the long-term vacant offices can be used for renovation, whereas 15% of the vacant offices can be adjusted to accommodate new function(s) and for another 15% of the vacant offices it is better to demolish the buildings (ANP, 2012b).

The article on the left page shows the current situation of re-using vacant office buildings in Amsterdam. Michiel Mulder claims in this article that already two property funds cannot meet their payment expectations and therefore the properties of these funds will be sold for bottom prices. This is a great opportunity for starters, students and artist, because they can buy these units for bottom prices and have enough money left for the renovation of these units (Mulder, 2012).

“Old ideas can sometimes use new buildings. New ideas must use old buildings.”

- Jane Jacobs -
(Jacobs, 1992, p. 188)

As the article has already explained; vacancy is an actual problem. In the future the vacancy will only become worse. This is because of the economic crisis and the resulting uncertain situation on the real estate market. This will lead to the fact that more offices and other vacant buildings will be re-used for housing purposes.

Our definition of dwelling revealed that the word ‘dwelling’ contains a history. We have interpreted this history not only as the prior dwelling experience for the dweller but also as the past for a dwelling. The history of a dwelling situated in a certain building envelope contains not only its own history but also the history of the previous function of the building. According to Jane Jacobs, old ideas can sometimes use new buildings and that new ideas must use old buildings (Jacobs, 1992, p. 188). We would like to turn this around and start with new ideas which are realized within old building and use these old ideas in the design for new buildings.

The way how to re-use existing buildings for dwelling programs will be the main subject of our research. For our graduation studio ‘At Home In The City Amsterdam’ we have defined our research theme as ‘Dwelling within the new history’. To clarify our research theme we will first explain why we have chosen for these exact words.

We have chosen for the word ‘dwelling’ and not for ‘living’ because dwelling is linked to the dwelling itself, whereas ‘living’ is much wider and does not have to be linked with the dwelling itself. The word ‘within’ is used to specify that it is within a certain building envelope.

We have chosen for the word ‘the’ and not for ‘a’, because ‘the’ defines that this research is about specific case studies and the outcome is also specific in the form of a matrix and toolbox.

The words ‘new history’ has two meanings: on the one hand it means new dwellings in historical buildings and on the other hand it means new dwellings with a new history.

RESEARCH QUESTION

How can we learn from building ensembles transformed into different dwelling programs to enrich the new building stock?

The endresult of our research on 'dwelling within the new history' will lead to four manuals and a toolbox for enriching new residential buildings. To maintain that this new residential building will last for a long time, we have defined our research question, to help us achieving this.

Our research question is: How can we learn from building ensembles transformed into different dwelling programs to enrich the new building stock? This research question will not be interpreted by everybody in the same way. Therefore we have defined our interpretation of some words of our research question. In this way we make sure that everybody will interpret the research question in the same way as we do.

In this research the words 'building ensemble' are used for one building block. The form does not matter, neither the number of building parts, as long as the different building parts are connected to make it one building ensemble.

This research sees 'transformed' as a way of adjusting the existing building to adapt to new dwelling typologies within the building. For this research it does not matter whether the building structure has been changed, the facade has been changed, or elements have been added to the building. The only condition for this transformation is that the original building must still be recognizable after this transformation.

In this research 'dwelling programs' can be defined as different dwelling typologies within one building ensemble combined with other functions.

RESEARCH QUESTION

The manuals, which will be part of the end result of this research, define the already realized combinations of different typologies in re-used building. A toolbox, which will be another part of the end result of this research, defines the different elements that can be used to allow transformations during time. For this research we use both these manuals and the toolbox to 'enrich the new building stock'. Building stock is defined as the whole range of realized building. In the conclusions of our research we will discuss if the manuals and toolbox elements are also to define as opportunities for new build buildings, to enrich the existing building stock.

RESEARCH QUESTION

Sub questions:

1. What makes a building transformable into a dwelling program?
2. How can different dwelling programs be realized?
3. What is the difference between a dwelling in a re-used building and a dwelling in a new building? What can we learn from it?

Everybody will now interpret this research question in the same way. The research question in itself is difficult to answer, that is why we have defined three sub-questions, which are shown on the left part of this page.

The first sub-question is used to define all the elements in the transformed buildings, which made the transformation possible. Examples of these elements are the grid size, the dimensions, the structure, the materials and the assembly. All these elements together will form the toolbox, which will be the actual answer on this sub-question. This toolbox can be used in the future for enriching the existing building stock.

In order to be able to answer sub-question two, we have defined 6 more detailed questions, which are based on 6 defined research categories. Every category contains 4-6 typologies. These will lead to the manuals.

1. *How can a mix of functions combined with a dwelling program ensure meetings between different users, to enrich the building?*
2. *How can the outside space be used to enrich the building?*
3. *How can the circulation in the building ensure meetings between different users, to enrich the building?*
4. *How can different dwelling typologies be combined in one building?*
5. *How can the outside space be used to enrich a dwelling?*
6. *How can the combination of living and working lead to the enrichment of a building?*

The answers on these questions will give the guidelines for making a matrix and in this matrix you can see the how different typologies can be combined to realize different dwelling programs, which will be the actual answer on this sub-question.

RESEARCH QUESTION

For subquestion three we will check if the manual elements and the toolbox are applied to the new building stock. When manual elements or elements from the toolbox are not already realized within a new building, then this will be an opportunity for enriching the existing building stock. The answer on this subquestion contains all these opportunities for enriching the existing building stock. These opportunities can be used in designing a new kind of residential building.

“A case study is an empirical inquiry that investigates a contemporary phenomenon within its real-life context...”

- Robert Yin -
(Yin, 1994, p. 13)

These sub-questions will be answered by using the research method: case study research (Wang, 2002, p. 94). In this research method case studies will be analysed and these analyses combined with theoretical information about that subject, which will lead to the answers of the sub-questions.

According to Robert Yin, a case study consists of five main points: "1. a focus on either single or multiple cases, studied in their real life contexts; 2. the capacity to explain causal links; 3. the importance of theory development in the research design phase; 4. a reliance on multiple sources of evidence, with data needing to converge in a triangulating fashion; 5. the power to generalize to theory" (Groat, 2002, p. 346). This research will use these five points in order to make a set of tools for the enrichment of new residential buildings.

In order to make these five points more clear, we have defined our own interpretation of these five points.

The case study strategy contains much more than a simple study of what there physically is. It also involves studying the relationship of a case to the more layered context of it. These layers are involved with a physical world, but also with the history of the case and its current economic, political, social and cultural context. That is in our opinion what Yin has meant for point 1.

Between these different contextual layers there are often casual links. For point 2 it is important to mention those causal links, because they can influence the way how the building has been transformed or how the building now is being used.

The reason why and how these links have been caused, are based

upon assumptions. It is important to verify these assumptions to see if they are true. These assumptions are part of point 3.

For point 4 it is necessary to use literature references on the causal links. In this way, these literature references can help in verifying point 3. These references link the hypothetical casual links and the literature based theory together. This makes the hypothetical links more facts based.

In order to be able to generalize the founded information into a theory (point 5), it is important to find more case studies in which the causal links exists. Besides that it is also important to find these causal links also in literature references. And when this is the case, then it is possible to generalize the founded information into a theory.

“Every case should serve a specific purpose within the overall scope of inquiry.”

- Robert Yin -
(Yin, 1994, p. 46)

For the chosen research method of using case studies for answering the subquestions it is now important to define some criteria for selecting the case studies for our research.

We have defined the following criteria for choosing case studies:

- The case study should be an existing building.
- The case study needs to be one building block. The form of the building does not matter, as long as the building parts are connected to make it one building.
- The new use of the case study needs to be predominantly dwelling.
- At least 5 dwellings should be realized within the transformation of the building.
- The case study should contain different dwelling typologies combined with other functions.
- The case study should contain at least one typology of every category; in total we have defined 6 categories. So the building needs to contain 6 different typologies from the following categories: public functions, outside space building, access to dwelling, dwelling, outside space dwelling and work/live.

With the criteria for choosing the case studies, we can now select the case studies for our research. In our research we will need criteria for analyzing and comparing the different case studies.

The case studies will be analysed according to the following points:

- The dimensions of the building.
- The structure of the building.
- The private, collective & public spaces in the building.
- The public functions in the building.
- The circulation in the building. For the circulation we will look at the entrance, corridors, lifts and staircases.
- The private outside space, collective outside space & public outside space.
- The different dwelling typologies in the building.
- The private, collective and public outside space of the dwellings.
- The areas in the building used for work, live-work, work-live & live.
- The daylight access in the dwelling.
- The assembly of materials in the interior of the dwellings.

$$.. = .. + .. + .. + .. + .. + ..$$

In this research we will focus on the analysis of transformed buildings with a new dwelling program. Within this focus on transformed buildings we will now describe the process for the creation of the manuals and a toolbox.

MANUAL

For the creation of the manuals, it is necessary to define first six categories with each 4-6 typologies. The categories with their typologies are:

- public functions: in the base, on top of, next to and through;
- outside space building: stairs, street in the air, roof, courtyard and atrium;
- access to dwelling: street, deck, gallery and corridor;
- dwelling: flat/apartment, loft, maisonette and split-level apartment;
- outside space dwelling: terrace, serre, loggia and balcony;
- work-live: home occupation, live-work with, live-work near, work-live near, live-work nearby and work-live nearby.

These different typologies will be defined more clearly in the next chapter.

The first step in the process is to analyse the case studies on these typologies. The second step is to create the manuals in the form of a mathematical sum. In order to give a good overview of the realized typologies combinations, the sum will exist out of the diagrams of the realized typologies for that case study.

LOCATION	CHARACTER	FACADE
ENVELOPE	COMPOSITION	STRUCTURE
PROGRAM	DWELLINGS	DAYLIGHT

TOOLBOX

The first step in the process of the creation of the manuals is to analyse the case studies on the scale of the building and on the scale of the program. All the case studies will be analysed on the following points: the grid size, the dimensions, the structure, the materials and the assembly. The second step in the process is to simplify the analytical drawings of the case studies into diagrams. This is necessary for making the information of the case studies more generic. The third step in the process is to make a toolbox in the form of a table. The boxes of the table will be filled with the diagrams of the location, the character, the facade, the envelope, the composition, the structure, the program, the dwellings and the daylight of which characterize buildings which are good applicable for transformation to a dwelling program. In this way the created toolbox gives a good overview of all the tools which are used in the case studies.

Toolbox (own illustration)

PUBLIC FUNCTIONS

After the description of the research method and the criteria for selecting and analysing the case studies, it is now important to define the different topics on which we will analyse the case studies. For each topic we have defined some typologies. These typologies are interpreted by everyone in a different way, that is why we will define our interpretation of these typologies.

For our research we have defined typologies on six topics. Three topics are on the scale of the building. Three topics are on the scale of the dwelling.

We will start by explaining the topics on the scale of the building. On the scale of the building we have formulated the topics of public functions, outside space and access to the dwelling.

There are four typologies formulated for PUBLIC FUNCTIONS in the building. Public functions are functions which are (also) meant for people who live outside the building. Examples of public functions are a supermarket, a theatre, a restaurant, stores, etc. The typologies for public functions will be discussed first.

IN THE BASE

Most buildings are clearly defined in two parts. Those buildings have a clear upper part and a clear bottom part. When the bottom part houses public functions, and the upper part houses dwellings, we type these buildings as buildings with public functions IN THE BASE.

ON TOP OF

When the bottom part of a building houses dwellings, and the upper part houses public functions, we type these buildings as buildings with public functions ON TOP OF it.



in the base



next to



on top of

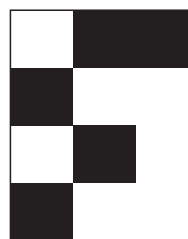

through

Typologies public functions (own illustration)

PUBLIC FUNCTIONS

NEXT TO

Some buildings have public functions on all levels of the building. Still there can be a clear distinction in two parts. This happens when the two parts are next to each other. When one part houses dwellings and one part houses public functions, we type these buildings as buildings with public functions NEXT TO dwellings.

THROUGH

In some rare occasions public functions are spread throughout the whole building. Here, public functions take place on different levels of the building and on different sides of the building. When this occurs we type these buildings as buildings with public functions THROUGH it.

OUTSIDE SPACE

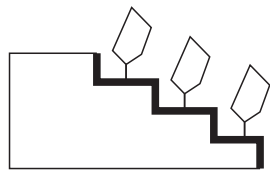

stairs

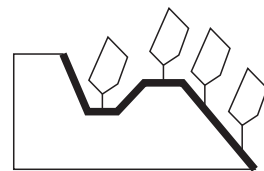

street in the air

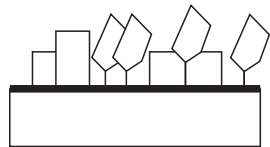

roof

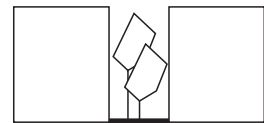

courtyard

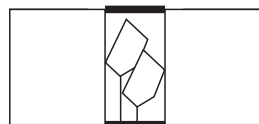

atrium

Typologies outside space (own illustration)

Another topic we have analysed is the outside space. For our research we have defined outside spaces on the scale of the building and on the scale of the dwelling. The outside spaces on the scale of the building are for collective use. This means that the outside space can be used by both inhabitants and non-inhabitants. The outside spaces on the scale of the dwelling are for private use. This means that the outside space is used by the dweller(s) of the adjacent dwelling. On the scale of the building we are using five different typologies of OUTSIDE SPACE. These will be discussed first.

STAIRS

The most economical way to have outside space combined with a building is when the outside space is on top of the building. This is possible in three ways. The way in which the outside space becomes most private, when every level has its own collective space, is when the outside space is placed stepped along the façade. Most of the times this results in the STAIRS, which is oriented to the sun.

STREET IN THE AIR

The way in which the outside space becomes most public, when it is freely accessible for everyone, is when the outside space is placed on a spiral/ramp which evolves into the air. To address to its free accessibility the spiral/ramp is accompanied by a street. For this reason we call this typology of outside space on the building scale the STREET IN THE AIR.

ROOF

The clearest example of outside space on top of a building, is when the outside space is situated on the ROOF. When this occurs the outside space becomes one big collective space; other than the

OUTSIDE SPACE

stairs. Other than the street in the air, the roof is not accessible for everyone. Concluded this typology is exactly in between the stairs and street in the air.

COURTYARD

A less economical way to have outside space combined with a building is when the outside space is within the building parameter. This is possible in two ways. In the one way, the outside space lays within the building block and is open to the sky. This typology is known as the COURTYARD.

ATRIUM

In the other way, the outside space lays within the building block and is not open to the sky. To call it an outside space the roof of this inner space needs to be glazed. In this way the building houses a greenhouse inside. This typology is known as the ATRIUM.

ACCESS TO DWELLING

The last topic we have analysed on the scale of the building is the ACCESS TO the DWELLING. This topic also has a collective character, when it is only used by dwellers. On the access to the dwelling we are using four different typologies.

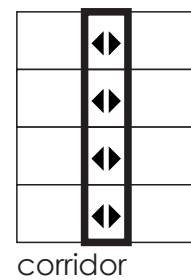
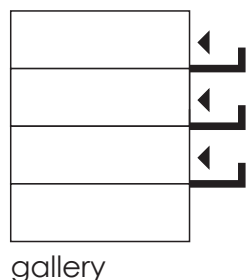
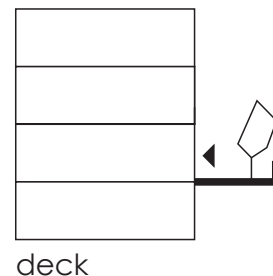
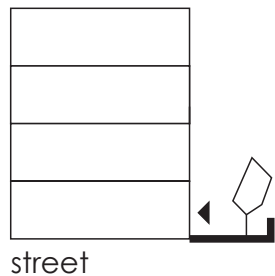

STREET

In Holland people address great value to the idea of 'a front door at the street', according to Jürgehake et al. This typology gives the possibility to a front garden. Another positive point of this typology can be that you don't have to walk any stairs or use an elevator to access your front door. Consequently further vertical transport takes place within the dwelling itself. The Dutch row house is a clear example. The street can also give access to secondary vertical access points. A clear example of this is the portico.¹

DECK

In the book 'Het ontwerpen van woningen' is a deck defined as a street in the air. This typology also gives the possibility for a front garden. In this case further vertical transport takes place within the dwelling. The wideness of the deck also gives possibilities for secondary vertical access points.²

GALLERY

The term gallery is defined by Jürgehake et al. as a slim deck. There is no possibility for front gardens. The gallery gives only access to adjacent dwellings. The gallery can be open to the outside or be closed off. Either way the gallery is accessed by natural daylight. The gallery can be within the façade or 'hanging' on it. The gallery can be directly connected to the dwellings or connected with them through bridges.³

Typologies access to dwelling (own illustration)

ACCESS TO DWELLING

CORRIDOR

According to Jürgehake et al. the corridor is a hallway within the building. Other than the other access typologies, the corridor is most of the time dark. This is seen mostly as the biggest disadvantage of the corridor. A real positive point of the corridor is that the facades are free of circulation systems which block the direct natural daylight.⁴

Now we will address to the topics on the scale of the dwelling. These topics address to the private realm. On the scale of the dwelling we have formulated the topics of the dwelling itself, its outside space and the topic of work/live. There are four typologies formulated for DWELLINGS. These typologies will be discussed first.



flat/apartment

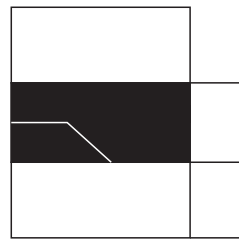

loft



maisonette

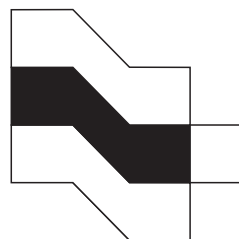

split-level
apartment

FLAT/APARTMENT

Jürgenhake et al. states that an apartment on one floor in a dwelling ensemble is called a flat. You could claim that a tower of flats is a stacking of bungalows. The different rooms within a flat are separated by walls.⁵

LOFT

According to Jürgenhake et al. they started in America using old offices and factories for dwelling purposes. The resulting lofts are more spacious than the standard dwelling typologies. In this way they inspire the dwellers and designers to multiple variations of organising the floor plan. This typology is mostly situated within old buildings, in which the old visible structure determines the division between spaces. Separating walls are only used for service blocks, which house wet cells and sometimes kitchen blocks. When the floor heights in old buildings are higher than with standard dwellings, there are possibilities for additional floors. These additional floors have the character of a mezzanine.⁶

MAISONETTE

When an apartment in a dwelling ensemble has multiple floor levels it is called a maisonette, as this is defined in the book 'Het ontwerpen van woningen'. When this typology has multiple levels, by an amount of square meters equal to a flat, it has a smaller footprint. In this way you can have more maisonettes on one corridor or gallery

Dwelling typologies (own illustration)

DWELLING

than flats. There are also no corridors or galleries needed on every floor. Within the dwelling itself there is always vertical circulation. A maisonette can be loft like; without any separation walls, but it can also be with separation walls.⁷

SPLIT-LEVEL APARTMENT

In the book 'Het ontwerpen van woningen' is explained that when a maisonette reduces the amount of galleries or corridors by half or even more, the split-level typology reduces the amount of galleries or corridors by one third. A split-level consists of one third of the dwelling on access level, and the rest of the dwelling is a half storey below or above this access level. A split-level apartment can be loft like; without any separation walls, but can be also with separation walls.⁸

OUTSIDE SPACE DWELLING

Another topic addressed before are the outside spaces. For our research we have defined outside spaces on the scale of the building and on the scale of the dwelling. The outside spaces on the scale of the building are for collective use. This means that the outside space is to use by multiple persons. The outside spaces on the scale of the dwelling are for private use. This means that the outside space is to use by the dweller(s) of the adjacent dwelling. On the scale of the dwelling we are using four different typologies of OUTSIDE SPACE. These will be discussed here.

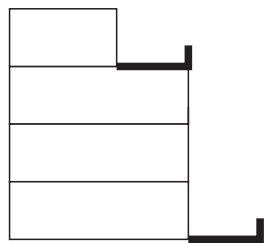

terrace

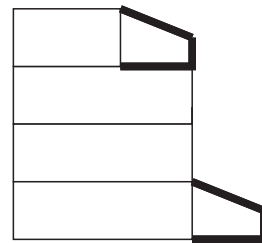

serre

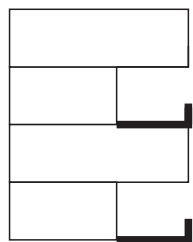

loggia

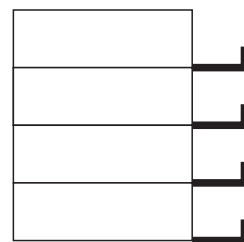

balcony

TERRACE

A free standing house with a garden around it is the ideal situation for many people in our country. Within a dwelling ensemble this garden becomes a terrace, which can be situated on ground level or have the character of a roof terrace. Characteristic for the terrace is its roof, which is formed by the sky and in this way the sun can be directly on top of it and illuminate it during the whole day.⁹

CONSERVATORY

The conservatory is also orientated to the sky, but is physical closed off by glass, according to Jürgehake et al. It is evolved out of a glasshouse. When it is made out of glass and cannot be totally opened it is mostly used as a transition space between terrace and dwelling. When the facade can totally be opened it can be used as some kind of loggia.¹⁰

LOGGIA

Jürgehake et al. defines a loggia as an outside space within the facade. In the older days a covered gallery along a palace was also called a loggia. Also in the Italian renaissance they often used loggias. A loggia can be situated on ground level; becoming a

OUTSIDE SPACE DWELLING

veranda. It can also be on higher levels within a building. A loggia is in some way a room; with a ceiling. On the other hand, the facade has no glass, so you are totally in the outside climate.¹¹

BALCONY

A balcony is placed outside the façade; 'hanging' on it.¹² A balcony can be on ground floor, but is most of the time situated on the higher levels. Like a loggia, most of the time it has a ceiling due to existence of the balcony of the neighbours above.

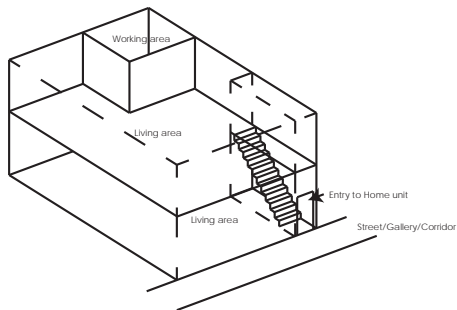

home occupation

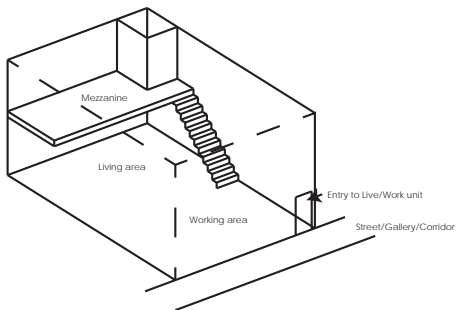

live-work with

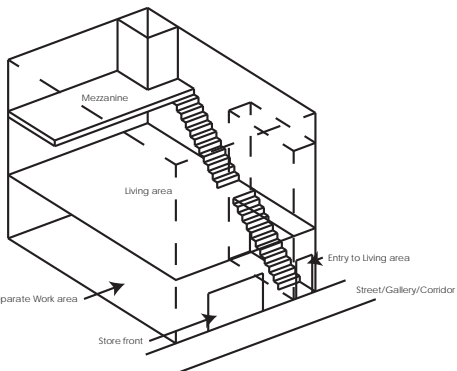

live-work near

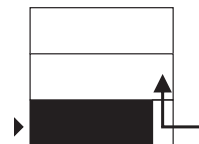

For our research we are using six different typologies for work/live units. The combination of working and living in one building can be splitted up in three main categories: home occupation, live-work and work-live. According to Thomas Dolan, home occupation is used when the work occurs in the dwelling itself. The category live-work is used to define that working and living takes place within the same building, but dwelling is the dominant function of the building. The term work-live is used for buildings where working and living also take place within the same building, but where working is the most important function of the building.¹³ The six different typologies for work/live will be discussed here.

HOME OCCUPATION

Home occupations is defined by Dolan as small work activities that will take place within the dwelling itself. These work activities can take place in a separated work room (like a studio, office or workshop room) in the dwelling or living space itself.¹⁴

LIVE-WORK WITH

The term live-work with is used for a dwelling typology that consists of one big room where work and living activities take place.¹⁵ These activities are not separated from each other and an example of this type is the loft.

LIVE-WORK NEAR

Dolan explains the 'live-work near' as one unit where work activities and living takes place within the same unit but where these functions are separated by a wall, ceiling or floor.¹⁶ These functions have both their own entrance and can function separately.

Typologies work/live (own illustration, based on (Dolan, 2012, pp. 17-18))

WORK-LIVE NEAR

Work-live near is almost the same as live-work near, because both working and living activities are within the same unit and are separated by a wall, ceiling or floor. These functions have both their own entrance and can function separately. The only difference is that in this type the working space is much bigger than the living space, because working is the dominant function in the category work-live.¹⁷

LIVE-WORK NEARBY

According to Dolan is the live-work nearby term used to identify that living and working activities take place within the same building, but not within the same unit. Both units are situated separately within the building. The functions are separated within the building and they have both their own entrance.¹⁸

WORK-LIVE NEARBY

In the book 'Live-work planning and design' is the term work-live nearby used to identify that working and living activities are within the same building, but are not physically connected with each other. Both functions can be used separately and have therefore their own entrance. In work-live typologies is the working space much more important than the living area, therefore is the working area in this type the working area much bigger than the living area.¹⁹

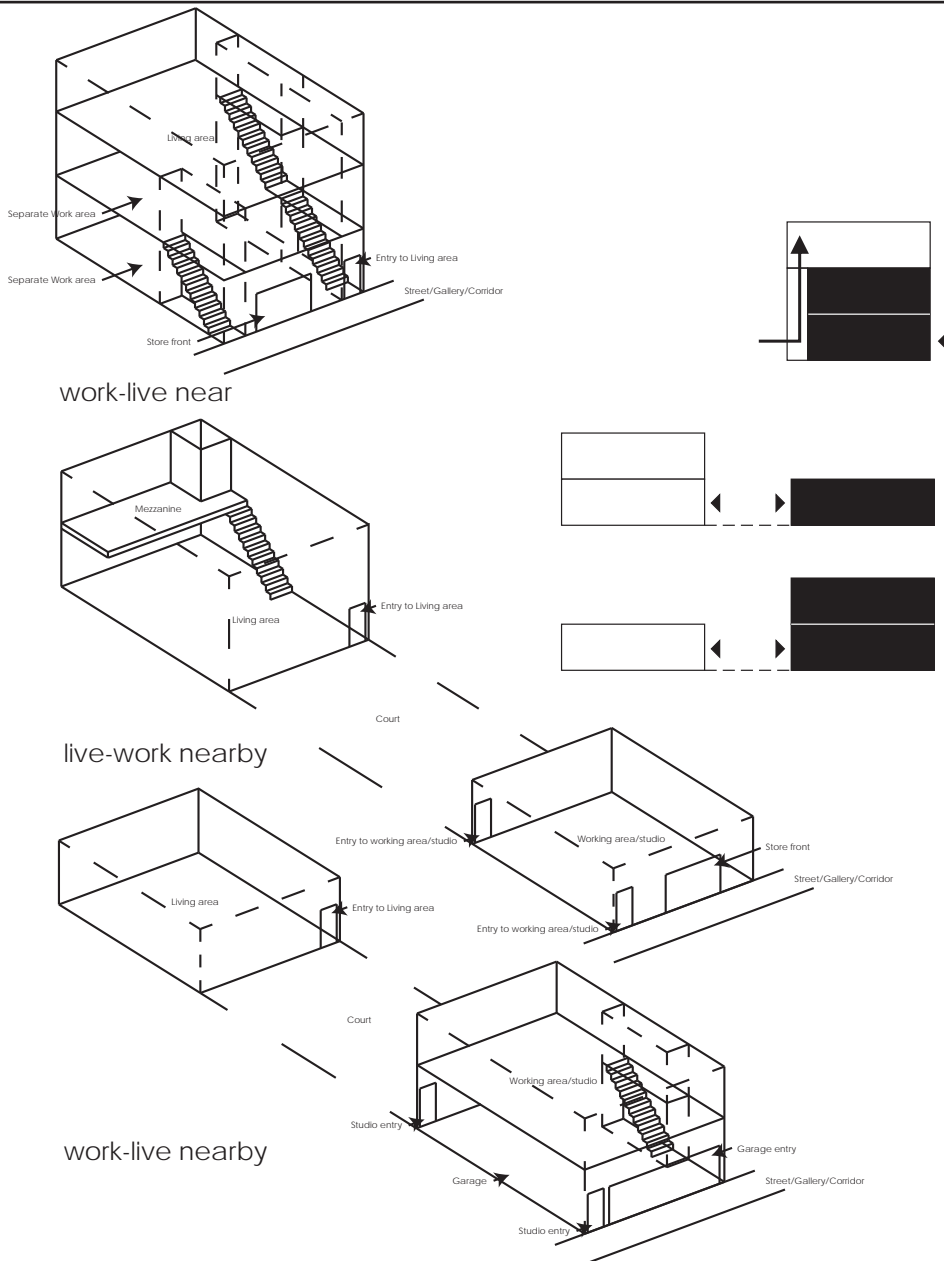

Typologies work/live (own illustration, based on (Dolan, 2012, pp. 14-18))

TYPOLOGIES

PUBLIC FUNCTIONS



in the base



on top of

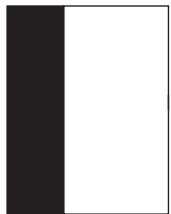

next to

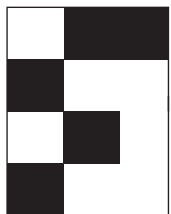

through

OUTSIDE SPACE BUILDING

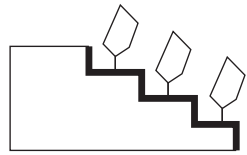

stairs

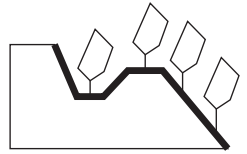

street in the air

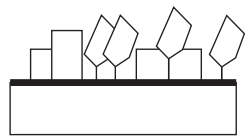

roof

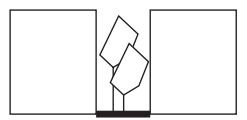

courtyard

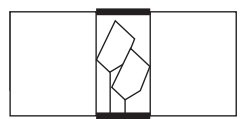

atrium

ACCESS TO DWELLING

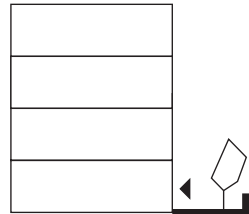

street

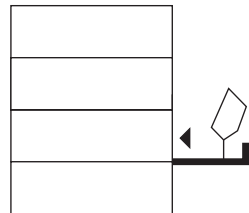

deck

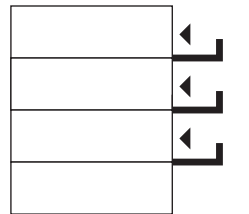

gallery

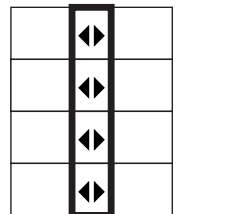

corridor

DWELLING



flat/apartment

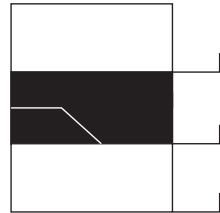

loft



maisonette

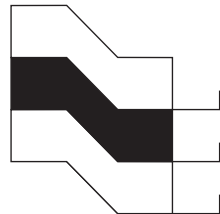

split-level apartment

OUTSIDE SPACE DWELLING

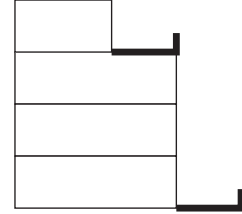

terrace

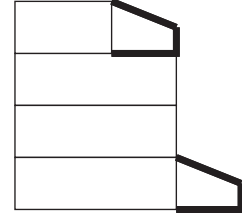

conservatory

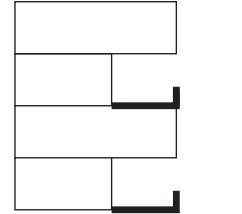

loggia

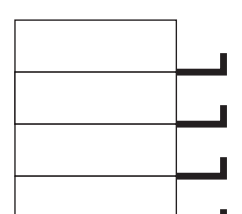

balcony

WORK-LIVE



home occupation



live-work with

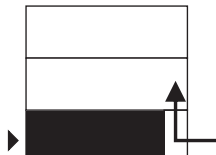

live-work near

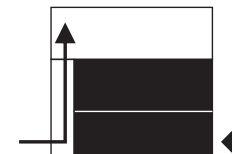

work-live near

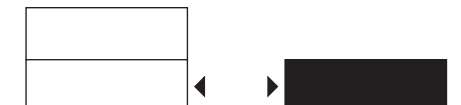

live-work nearby



work-live nearby

The six main categories with each four till six typologies (own illustration)

FOOTNOTES

1. JÜRGENHAKE, et al, J. 2005. *Het ontwerpen van woningen*, Delft, Publicatiebureau Bouwkunde, (p. 86).
2. Ibidem (p. 89).
3. Ibidem (p. 86).
4. Ibidem (p. 88).
5. Ibidem (pp. 80-81).
6. Ibidem (p. 85).
7. Ibidem (p. 82).
8. Ibidem (p. 83).
9. Ibidem (p. 182-183).
10. Ibidem (p. 181).
11. Ibidem (pp. 177-180).
12. Ibidem (p. 179).
13. DOLAN, T. 2012. *Live-work planning and design. Zero commute housing*, New York, John Wiley & Sons, (pp. 11-14).
14. Ibidem (p. 11).
15. Ibidem (p. 17).
16. Ibidem (pp. 17-18).
17. Ibidem (pp. 14-16).
18. Ibidem (p. 18).
19. Ibidem (pp. 14-16).

For each topic we have also defined some tools. These tools are interpreted by everyone in a different way, that is why we will define our interpretation of these tools.

For our research we have defined tools on nine topics. One tool is on the scale of the context. Six tools are on the scale of the building. Two tools are on the scale of the dwelling.

We will start, by explaining the tool on the scale of the context. On the scale of the building, we have formulated the tool of the location. The location explains what location will make a building most attractive to dwellers and thereby most durable.

Now we will address to the tools on the scale of the building. On the scale of the building we have formulated the topics of the character, the facade, the envelope, the composition, the structure and the program. The character will explain the what kind of appearance, what kind of materials and what kind of structural elements makes a building appealing. The facade will explain how the building volume is enclosed. The envelope will discuss the height, width and length of a building, to make it best suitable for transformation. The composition will explain which building forms are best for transformation and best suitable for a dwelling program. The structure will summarize what kind of structural elements are best suitable for transformation and best suitable for a dwelling program and how it is done. The program will tell what the best place will be for additional public or collective functions in a building.

Now we will address to the tools on the scale of the dwelling. These topics address to the private realm. On the scale of the dwelling we have formulated the tools of the dwelling itself, and of the day-

light penetration in the dwellings. The dwellings will explain what kind of dwelling type is most suitable for transforming buildings to a dwelling program. It also explains what dwelling type could have a new interesting form for application in new to build dwelling, and why. The daylight penetration will discuss the differences of light within old transformed dwellings and new dwellings.

CASE STUDIES

Het Paleis, Groningen, DAAD Architects

Warehouse 'Het Entrepotgebouw De vijf werelden', Rotterdam, Cepezed

Gasometer, Wenen, Jean Nouvel, Coop Himmelbau, Manfred Wehdom and Wilhelm Holzbauer

De Grote Enk, Arnhem, Bureau of Harmonic Architecture

A certain part of all re-used buildings contains one or more dwellings. We have selected four case studies of re-used buildings for this research.

The case studies, which are selected for our research, are shown on the left part of this page.

The case studies, which we have selected and analyzed, are all different kind of building typologies. The typologies are: courtyard buildings, warehouses, cylindrical buildings and offices. These typologies are defined, because in our research it became clear that some transformed buildings show more similarities to other transformed buildings than others. We have categorized them by scale, form, structure and former program. Before we will discuss the selected casestudies, the building typology they are categorized in will be explained more thoroughly; to give the case studies a broader context.

The selected case studies do contain at least one typology for public functions, outside space building, access to dwelling, dwelling, outside space dwelling and work-live.

Every case study will first describe general information of the project, the original function of the building, the transformation of the building and the realized program. The next pages of every case study will contain analytical drawing on the scale of the building, on the scale of the dwelling and on the scale of the interior of the dwelling. The analytical drawings on the scale of the building will start with the dimensions and this will be followed by the structure of the building, the private/collective/public spaces in the building, the public functions, the circulation and the outside space on

CASE STUDIES

the scale of the building. On the scale of the dwelling this will be followed by analytical drawings of the realized dwelling typologies, the outside spaces on the scale of the dwelling and the work-live typologies. The analytical drawings of the interior of the dwelling will show the daylight access in the dwelling and the assembly of materials.

COURTYARD BUILDINGS



Kruissherenklooster in Ter Apel (Hendriks, 2008, p. 12)



Abdi van Middelburg (Hendriks, 2008, p. 14)

HISTORY

Monasteries, barracks and schools can all be defined as courtyard buildings. That is why these building types will be discussed in this chapter.

The first monasteries in Western Europe were built at the end of the sixth century. The oldest monastery in the Netherlands was the St. Willibrord, which was founded in 714 in Susteren and has now been demolished. More monasteries were built in the tenth century in Thorn, Egmond, Tiel, Amersfoort and Elten, but from the original form of these monasteries is nothing left. From the twelfth century, a lot of monasteries were built due to the reforms of the monasteries.¹ The Netherlands had an important position in Europe with their five hundred religious communities in 1500. But due to the Reformation, immediately after the 'Tachtigjarige oorlog', a lot of monasteries were banned and immediately closed. This resulted in a lot of vacant medieval monasteries. Most of them were in the end demolished. Therefore there are only a few medieval monasteries left nowadays in the Netherlands. Examples of medieval monasteries, which have now lost their original function are: the '**kruissherenkloosters**' in Maastricht and **Ter Apel**, the '**Catharijneconvent**' in Utrecht, the '**Abdi van Middelburg**', the '**franciscanenklooster**' near Weert.²

Originally, monasteries have a great variety of functions. They house a monastic community and besides the worship and many different activities, they have also room for missions, like education, nursing and elderly care, science, culture, spirituality, hospitality, peace and reflection.³

In 1970, there were still 40,000 religious buildings in the Netherlands. Nowadays, there are only 700 monastic buildings left of which only 160 still have a religious function. In the coming years, it is expected

COURTYARD BUILDINGS



Kruisherenklooster in Maastricht (Camille Oostwegel, 2009)



Montfortanenklooster in Oirschot (Gemeente Oirschot, 2009)

that every month 1 of every 5 building will lose their religious function. The reason for this is the aging and the decreasing number of religious people which leads to a decline in church visits and monastic vocations.⁴

When monasteries are re-used for other functions, it is important to keep in mind the cultural and historical value of the building.⁵

With the adaptation of new functions to monasteries, it is possible to maintain the original shape, as it is the case for the '**Kruisherenklooster**' in Maastricht. This monastery has been transformed into a hotel-restaurant. But it can also be a problem to maintain the original shape, as it is the case for the '**Montfortanenklooster**' in Oirschot.⁶

The re-use of (medieval) monasteries is of all times, because a medieval monastery in Doesburg was already in 1661 transformed, after the Reformation, into an arsenal for the army. A new reason for reuse, which was in the past hardly a motive, is to prevent a building for demolition for cultural reasons.⁷

From the seventies and eighties, the community was involved in the reuse of religious buildings, due to the increasing number of conferences and symposia, brochures and literature. It was also important for the reuse of religious buildings, that 2008 has been declared as Year of the Religious Heritage. But still the decision to demolition of monasteries or other religious buildings is easy to take, without taking any cultural, functional or economic interests into consideration.⁸

In general, monasteries lend themselves easier for reuse than churches, because of the combination of simple private rooms, shared rooms, courtyards and a chapel. With this layout of different rooms it is usually no problem to transform the building into a hotel restaurant, a convention center, an apartment or a nursing home.⁹

COURTYARD BUILDINGS



In general, monasteries can be reused for other religious functions, for example a meditation center or funeral home. But it is also possible to reuse these buildings for public functions, like a museum, a library, an archive room, a concert hall, a theater and a convention center. It is even possible to reuse these building for non-public functions, like a nursing home, a sanatorium, a residential complex, an office complex, a community center or to continue traditional activities of that building such as a brewery, a binding or a farm.¹⁰

Other courtyard buildings are barracks, which can be splitted up in barracks for military purposes and fire stations. The '**Oranje Nassau Kazerne**' is the oldest military barrack built in the French time. This building, which has a rectangular floor plan with a length of 278 meters, is transformed into social housing combined with commercial spaces.¹¹

Fire stations and firehouses, buildings with a residential functions and which are used by a professional fire department, are only built in the big cities in the Netherlands. In the smaller towns, the fire departments consist of volunteers and these departments are housed in the spray house.¹²

In the period before the great urban expansion in Amsterdam, there were 9 fire stations in the city. In the nineties, there were 14 fire stations for the professional fire departments. Only 12 of them are still left. The oldest firehouse '**Kazerne Dirk**', which is still in use, is built in 1897 in Honthorstraat in the Netherlands.¹³

The oldest firehouses had stable spaces for horses on the ground floor. These stables were converted into garages for spraying cars in the twentieth century. Almost all fire stations have a hose tower, where fire hoses could be dried, and a climbing house, where climbing exercises were held. It is often not possible to give those towers a new function. An exception is the climbing house of the



Oranje Nassau Kazerne in Amsterdam (Kalk, 2010, pp. 60, 65)

COURTYARD BUILDINGS



Kazerne Dirk (Kalk, 2010, p. 62)

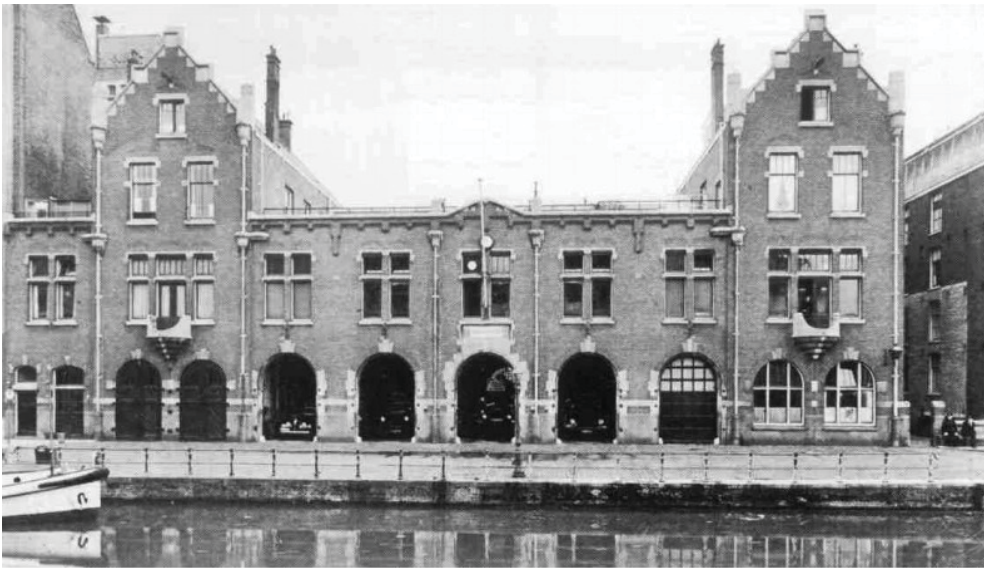

Kazerne W (Van Merwijk, 2007, p. 14)

restored fire station at the Ruyterkade, where the climbing house is used as a climbing hall for sports.¹⁴

In the depot of a fire station, heavy vehicles have always been stalled, which means that these areas are polluted with oil and petrol fumes. An obvious transformation of fire stations is to convert it into a garage or car-rental company. The soil is usually heavily polluted which requires rehabilitation before housing is permitted.¹⁵

In the eighties a number of former fire stations have been turned into houses, usually after they were first been squatted. The squatters transformed former fire stations into creative living-work spaces for artists. Vacant fire stations were also used by squatters, due to the presence of dormitories, canteens and shower rooms, for hosting large groups of sympathizers. A familiar example of this is the former 'Kazerne H' on the Prinsengracht, which was abandoned in 1979. The building was then be squatted for years under the name 'De Brandtweer'. Nowadays, the building consists of workshops for artists on the ground floor and dwellings on the floor above. Another example is the '**Kazerne W**' on the 'Nieuwe Achtergracht', where the soil was quite dirty and needed to be rehabilitated before living was permitted there. The building has now been converted into an apartment building.¹⁶

For many years, the police have a shortage of space and the fire stations have spaces left. Therefore in the seventies, a number of police stations have joined partly vacant fire stations. In the nineties, more fire stations became vacant and have been converted into police stations. Recent examples of the conversion of fire stations into completely police stations are the 'Kazerne Flierbosdreef' in the Bijlmer and the '**Kazerne Van Leijenberghlaan**' in Buitenveldert.¹⁷

COURTYARD BUILDINGS



Kazerne Van Leijenberghlaan in Amsterdam (Brandweer Amsterdam-Amstelland, S.D.)

The last category of courtyard buildings is the school buildings. Most of the old schools in Amsterdam are from the last decades of the nineteenth century and the first 3 decades of the twentieth century. That has to do with several decisions at national level. In 1880, a new building code was adopted with regard to the quality of school buildings. In 1901, the 'leerplichtwet' was introduced, which required that all children aged 6-12 years to attend school.¹⁸ Around 1900 and the sixties, there are also changes in secondary education system. The separation of education by type also implies that there are other requirements for school buildings. This educational reform and the decisions at national level have led to the construction of many new schools. Many existing buildings became therefore vacant and were squatted.¹⁹ In the nineties, the 'Brede scholen' are responsible for the biggest change in the housing of schools. The idea behind the 'Brede scholen' is the conviction that cooperation between the various parties that have to do with growing children, can benefit from each other. This development has led to a large increase in the number of social accommodations within or in the immediate vicinity of the school. Currently, more than fifteen hundred 'Brede scholen' are realised in the Netherlands. According to the latest reports, this trend is already on its return, because the high operating costs do not seem to outweigh the intended benefits. The newest vision is a pavilion structure, in which foot traffic to various facilities provides more liveliness and mixture in the neighbourhood.²⁰

It is known that many small school buildings from the sixties and seventies standing in residential neighbourhoods, are transformed into residential buildings, whether or not in combination with workshops or other creative work spaces. Artists prefer school buildings with large room' sizes, high ceilings and good daylight penetration.

COURTYARD BUILDINGS



In the seventies, many school buildings were squatted and later on legalized. Especially the schools with distinctive architecture were popular by squatters. From the mid nineties, many smaller old schools were transformed into creative live-work buildings.²¹

A good example is the former economics school building at the Marcus Street in Amsterdam East. This building was renamed **Marci Panis** in 2003. The transformation of this building consists of studios, rehearsal rooms, a restaurant, decor workshop, a concert/dance hall, a guesthouse for artists, a nursery, a space for a Turkish women's association and five dwellings for some users of the building. The combination of different disciplines and different users provides knowledge exchange between the different users and new partnerships. The public function of the building remained assured with this transformation.²²

Redevelopment of large school buildings consists almost always of commercial functions or a mix of social functions. These commercial functions are necessary to keep the renovation affordable.²³



Marci Panis in Amsterdam (Nationale renovatie prijs, 2005), (Kalk, 2010, p. 93)

CHARACTERISTICS

The most important and obvious characteristic of courtyard buildings is that one or more courtyards are realized within the building volume. The form of building can vary from L-shaped, U-shaped till completely closed blocks.

Monasteries, priories and convents are often formed by a large number of buildings. These buildings have different room' sizes, which offer the buildings flexibility of use.²⁴ Most of the time, barracks, fire stations and schools consist only of one building volume and not of several freestanding buildings. Sometimes, schools are built in a pavilion structure. This results in a number of freestanding buildings which form together the school.²⁵

COURTYARD BUILDINGS

Another characteristic of courtyard buildings is the cellular structure or layout of the building. The size of this structure varies between the different buildings types. Monasteries have for example a smaller cellular structure than schools, because residents of the monks have in general smaller measurements than classrooms. The cellular structure of barracks and fire departments varies within the building volume, due to the combination of smaller rooms (for the residents) and bigger rooms (for the heavy vehicles).

The long history of monastic architecture started originally with a simple shape combined with a simple organizing principle. From the early Middle Ages till the nineteenth century, this has changed into increasingly sophisticated ornamentation and detailing of the building shape combined with the traditional simple organizing principle. This led in the twentieth century to an increasing complexity of the design combined with the traditional organizing principle.²⁶

The facade of courtyard building is mostly characterized by brick masonry with a grid of windows. Barracks and fire stations do have a tight grid of big window openings, whereas monasteries have also a tight grid of window openings, but these window openings have mostly smaller measurements.

Large room sizes, high ceilings and good daylight penetration through big window openings characterize the interior of school buildings. The reason for the high ceilings and big window openings is to provide a maximum of daylight penetration for all children in the classroom (even for the children who are not sitting next to the big windows).²⁷



Minderbroederklooster near Weert (Hendrikx, 2008, p. 16)

COURTYARD BUILDINGS



Trappistenklooster in Berkel-Enschot (Bus-idee, S.D.)



Rijksacademie voor Beeldende Kunsten (Kalk, 2010, p. 61)

ADAPTATION

Courtyard buildings are characterized by a continuous cellular layout and are therefore easy to reuse for other functions.²⁸ The redevelopment of two Italian monasteries makes clear that a cellular structure can absorb functions of almost any size. Monasteries at Macerata and Urbino accommodate large libraries under the raised courtyards. Lecture halls and common rooms are realized within the existing fabric of the monasteries. The outer facade of these buildings remained the same, whereas the facades along the courtyards have been changed dramatically. The redevelopment of the Italian monasteries was successful due to the large size of the buildings.²⁹ *"Size and form play an important part: size because a large mass of building provides the client and the architect with greater flexibility; form because the courtyard plan is both compact and inward-looking."* (Cantacuzino, 1975, p. 27)

"Monastic buildings could be turned to housing, students' residences, hotels, shops, offices and even some forms of light industry (a legitimate extension, surely, of traditional monastic activities)." (Cantacuzino, 1975, p. 26) Some monasteries have large spans, which makes a transformation into a dining hall and a place for parties possible.³⁰

The '**minderbroederklooster**' near Weert was originally built in 1461, but is destroyed and rebuilt several times. In 1997, the monastery was transformed into a nursery home. Despite the necessary changes, the interior of the building has still very much its monastic character. This building is one of the most beautiful examples of re-using monastery buildings in the Netherlands.³¹

Traditional forms of activity, which were previously managed by the monks themselves, are now outsourced to private companies. This is for example the case for brewing, bookbinding and tourism.³²

COURTYARD BUILDINGS



Kazerne Oud Nico in Amsterdam (Kalk, 2010, p. 64)



Timorschool in Amsterdam (Kalk, 2010, p. 94)

Traditionally, many monastic communities were characterized by activities, which made them financially independent. An example of this is the '**trappistenklooster**' in Berkel-Enschot, which was the only place in the Netherlands where trappist beer was produced. When the number of monks declined, the beer production was outsourced to a large Dutch brewer, under the condition that the beer was produced with their own recipe.³³

Many monasteries have still tenanted farms, which were formerly exploited by the monks themselves. These monasteries are a big opportunity for touristic purposes.³⁴

Examples of successful redevelopments of barracks and fire stations are the 'Kavalleriekazerne' and the 'Kazerne Oud Nico'.

The 'Kavalleriekazerne' was taken into use in 1865 and housed a cavalry garrison. The ground floor of the U-shaped building was intended for the stables, the first floor was used as residents for the personnel and the attic was used for storage and straw. From 1955, the building is the annex of the 'Rijksmagazijn voor Geneesmiddelen'. In the early nineties, is the building reused for the '**Rijksacademie voor Beeldende Kunsten**'.³⁵

In 1973, the fire department left the '**Kazerne Oud Nico**' on the Ruyterkade and moved to a new building. The building was then used as living place, exercise space and theater storage. The building has been converted into cheap workspaces for artists in 2006.³⁶

Examples of successful reuse of school buildings, where a mix of commercial and public functions are realized, are the 'Timorschool' and the 'Het Sieraad'.

The '**Timorschool**' was built in 1912 and used as a trade school until 2004 and was then used as ROC. After an extensive renovation in 2007, the new function of the 'Timorschool' became a cultural and

COURTYARD BUILDINGS



Het Sieraad in Amsterdam (Straatkaart, 2009)

economic meeting place. Due to the large scale of the complex, the old school building houses several different functions, like an inviting hostel, a cafe/restaurant, a cinema, podiums, conference and meeting rooms, a digital football field, thirty-six small premises, an international research and conference center.³⁷

'Het Sieraad' was built in 1924 and functioned as a technical school and later as secondary school. In 2004, the building has been transformed into a center of knowledge, art and work. The building consists of small premises, workspaces for artists, a musical school, several high-tech and IT companies and a grand cafe.³⁸

Another good example of a redevelopment of a former school building is 'het Paleis' in Groningen. This building functioned as a chemical laboratory of the 'Rijksuniversiteit van Groningen'. This building has been squatted in 2006 and is later on transformed into a live-work building for artists. This building will be the main case study for this chapter.



Het Paleis in Groningen (DAAD Architecten, 2009)

COURTYARD BUILDINGS

HET PALEIS



COURTYARD BUILDINGS

HET PALEIS

Name: het Paleis

Location: Groningen

Original function: chemical laboratory of the 'Rijksuniversiteit van Groningen'

New function: dwellings, hotel, project rooms, workshop spaces, auditorium, offices, restaurants, ateliers

Architects: J.A. Vrijman (original design), DAAD Architects (re-use)

Area: 7500 sqm (BVO)

Year: 1910-12 (original design), 2009 (re-use)

COURTYARD BUILDINGS

HET PALEIS

HISTORY

'Het Paleis' was built between 1910 and 1912 after it was design by J. A. Vrijman. Until 1970 the building served as a chemistry laboratory of the 'Rijksuniversiteit van Groningen' until 1970. The building consisted of two wings and a center part, with an amphitheater for lectures and a large practical room.³⁹ In 1928 the building was extended with two sober, but carefully adapted wings at the Boterdiep and the rear side of the building. The building was extended on the eastside in 1957 and 1961.⁴⁰ After 1970 the building housed the Faculty of Medicine and just before the renovation, in 2006, the building was an anti-squatters building.⁴¹ In 2006, DAAD Architects made the design for the transformation of the building into a cultural live-work building.⁴²

BUILDING ENVELOPE

The 'Paleis' is a courtyard building with two courtyards. The footprint of the building is not completely rectangular because of the rotation of the southwest wing. But the building does fit within a rectangular of 74 meters by 48 meters. The building consists of four storeys of which the basement is semi-sunken in the ground. It has a total size of 7500 sqm BVO.

COMPOSITION

The composition of the building consists of 6 segments of which two segments are almost the same. Within the 6 segments of the building, the redevelopment has completed 3 main types of lofts and 3 main types of maisonettes. Ateliers, auditorium, studios and spaces for creative businesses are placed throughout the building. The depth of the wings made the building suitable for a transformation into a residential building. But also the two courtyards made it possible to provide enough daylight from two sides in the dwellings and other functions.



HET PALEIS | GRONINGEN, NETHERLANDS | 2009

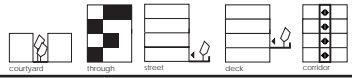

COURTYARD BUILDINGS

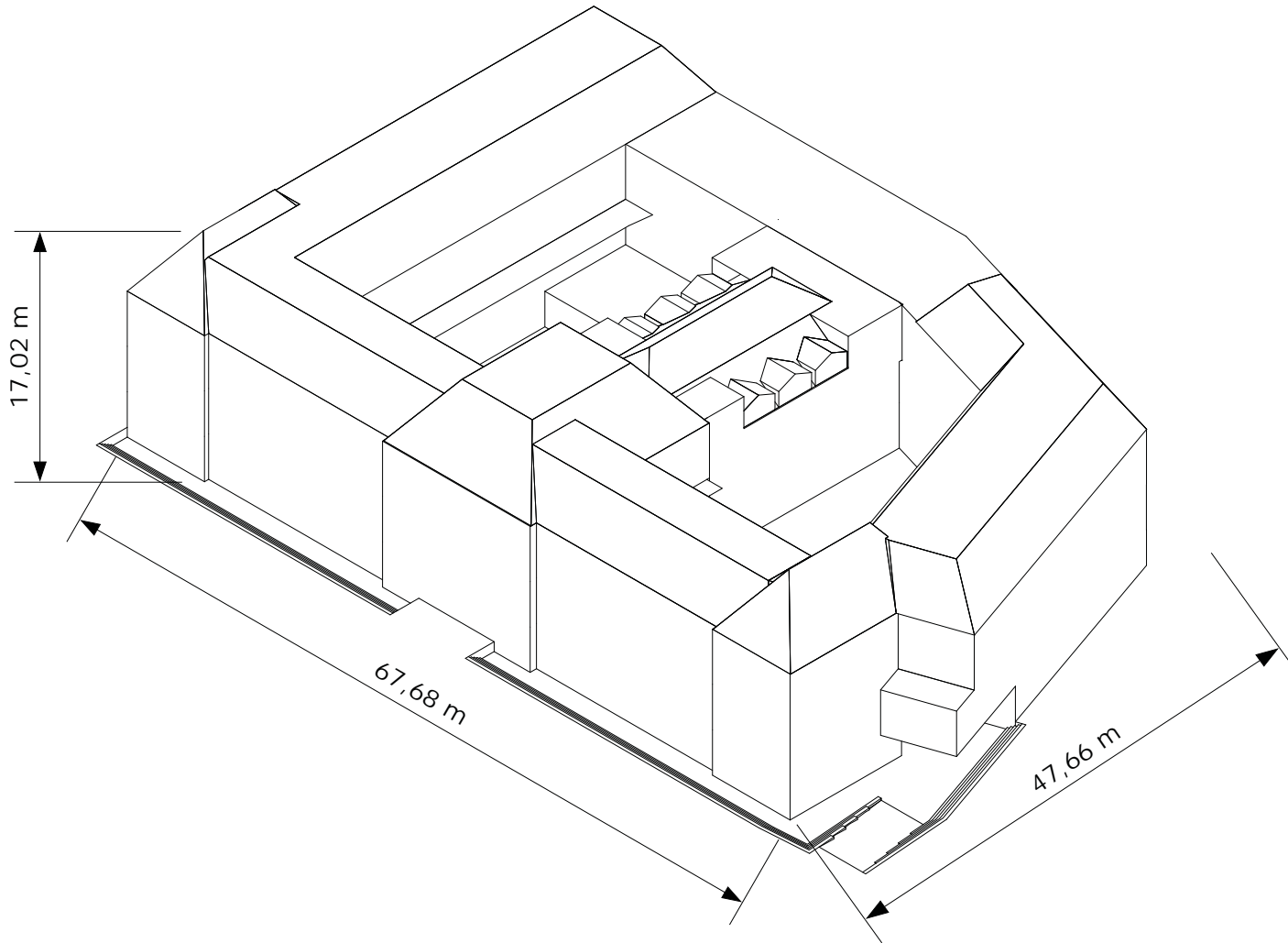

Building envelope scale 1:500 (own illustration)

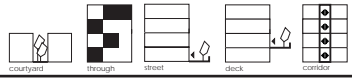

COURTYARD BUILDINGS

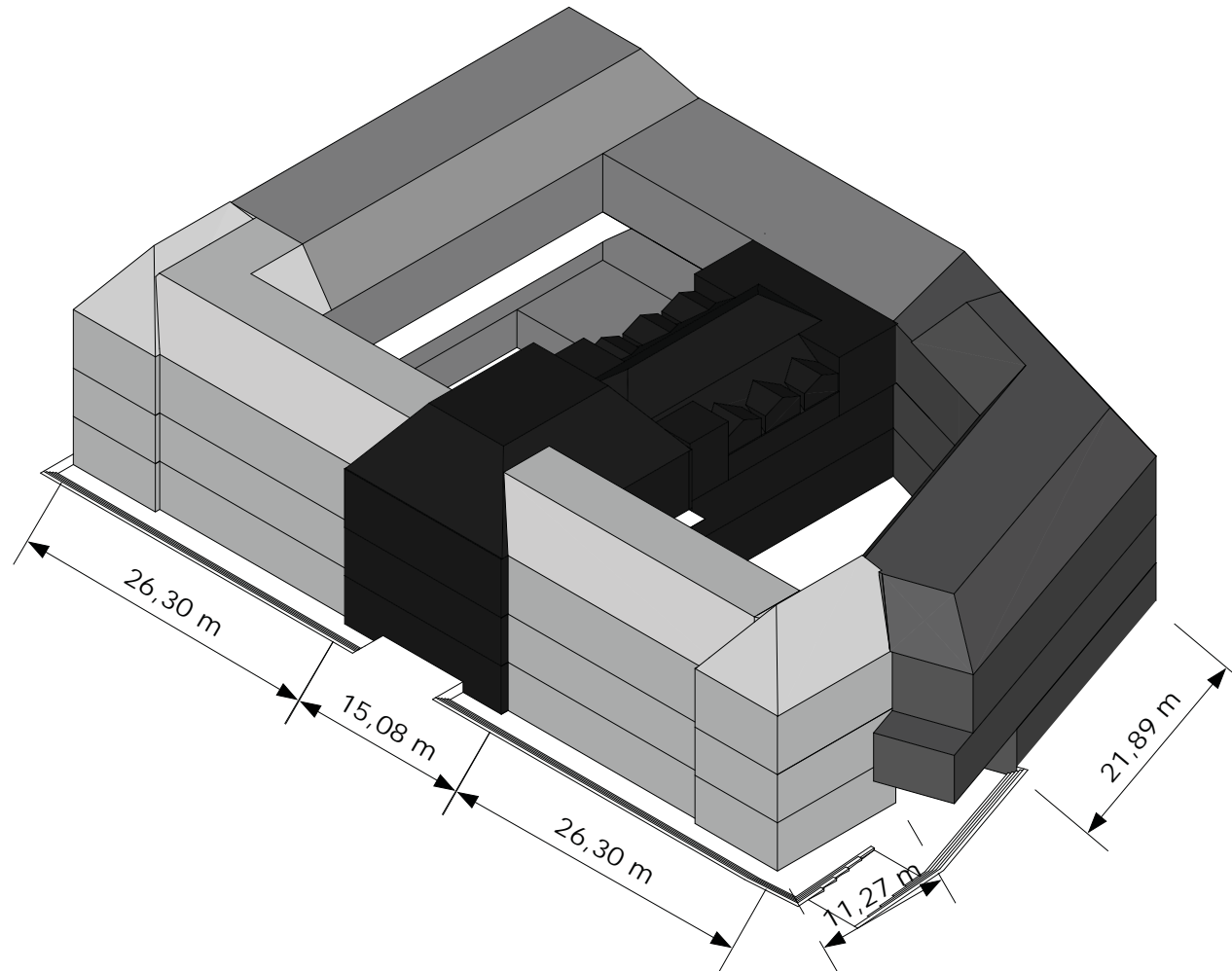

Composition scale 1:500 (own illustration)

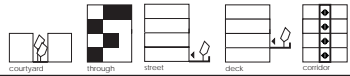

COURTYARD BUILDINGS



Basement

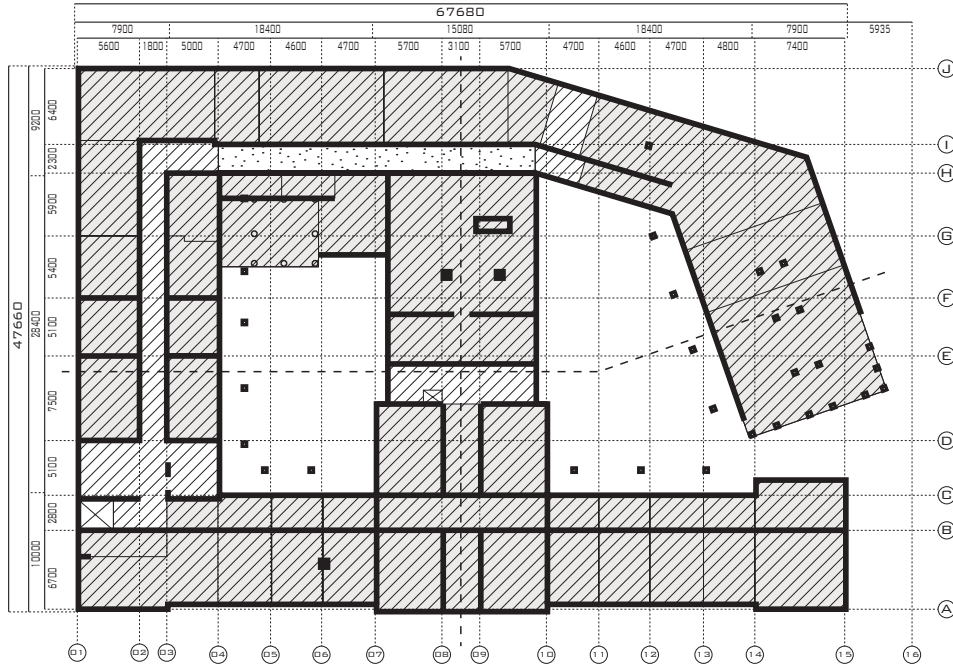

First floor

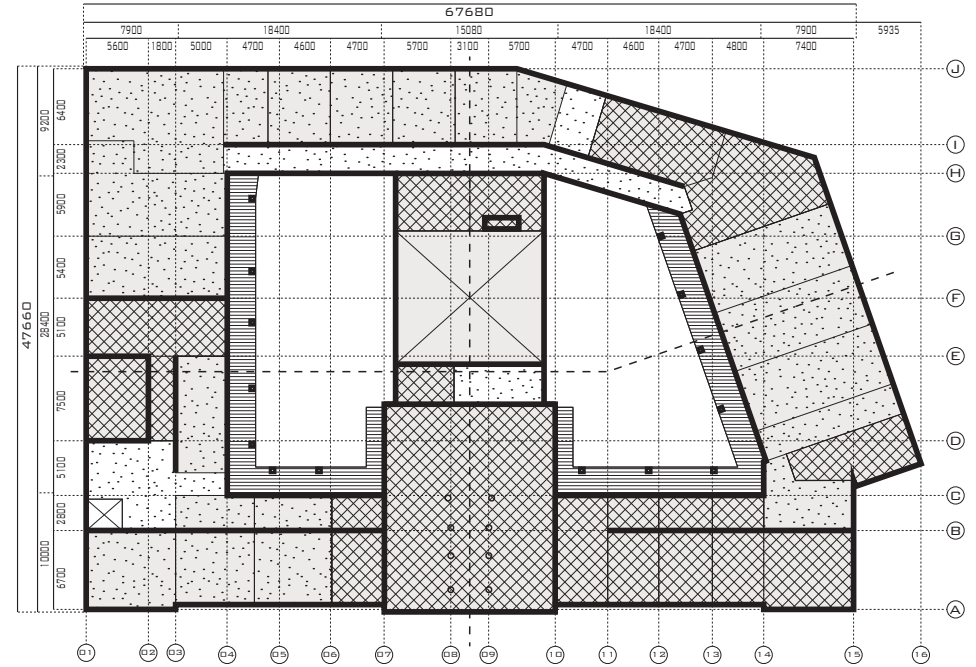

Cross section

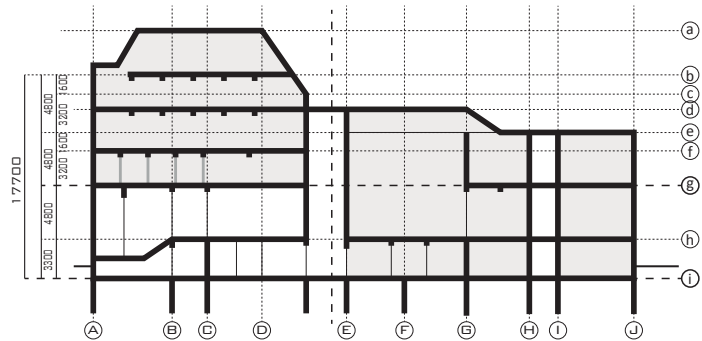

Longitudinal section

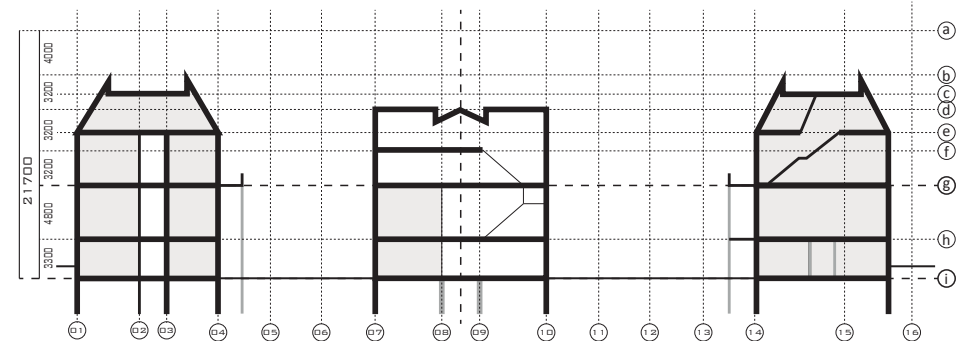

Grid structure (own illustration)

CONTENT

- brick floor
- concrete floor
- wooden floor
- steel floor
- functions
- circulation
- loadbearing walls
- columns
- columns on distance

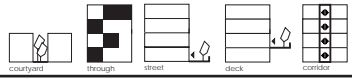

COURTYARD BUILDINGS

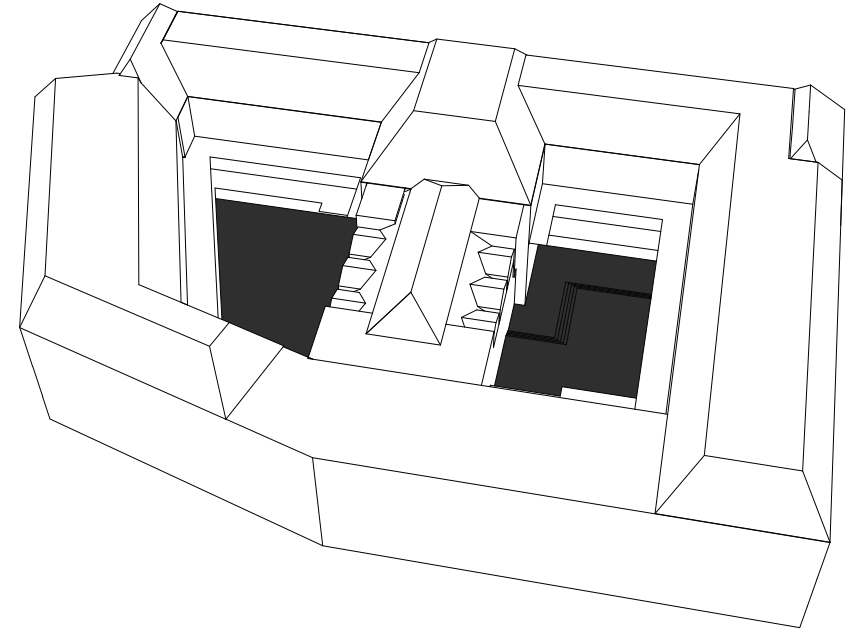
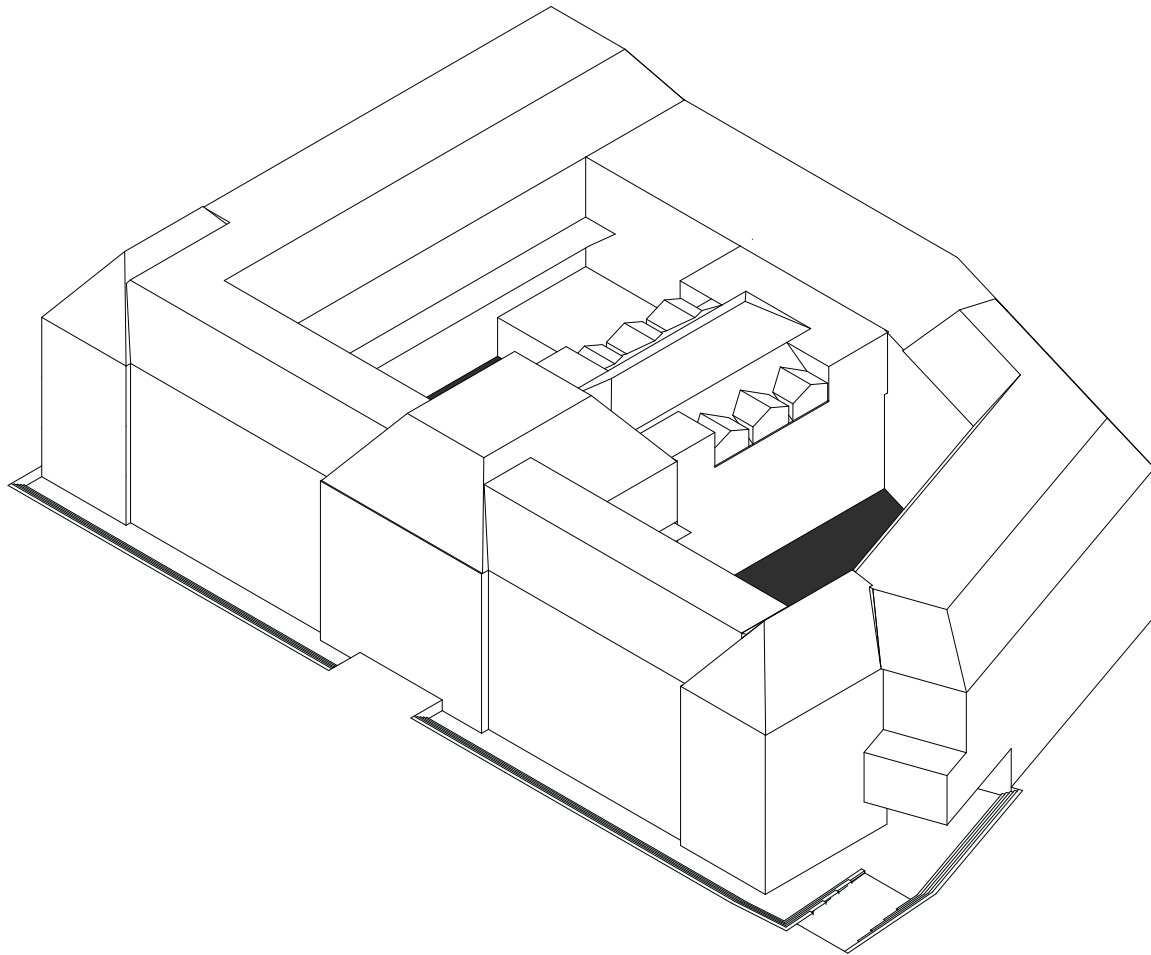

Courtyards axonometry scale 1:500, birds eye view (own illustration)



COURTYARD BUILDINGS

STRUCTURE

The plan of the building consists out of 3 compartments in the direction from north to south and 2 in the east-west direction. The east compartment (in the drawing the compartment on the left) is 12.4 meters width. This compartment is divided into three zones with in the middle a corridor of 1.8 meters. The mid compartment is in total 15.08 meters width and is also divided into three zones with a corridor of 3.1 meters in the middle of this compartment. The west compartment is also 12.4 meters width with also a corridor in the middle of 1.8 meters.

The south wing is 9.2 meters and consists of offices along the outer facade and a corridor of 2.3 meters along the side of the courtyard. The north wing is 10 meters and consists of workspaces and dwellings. The circulation of this wing is placed outside the building volume but within both courtyards. As a result of this the total size of the building is 73 meters by 47 with two courtyards of circa 29 meters by 14 meters.

The grid structure drawings show that most dwellings are in depth strictly situated within the grid. In length, also almost all dwellings are strictly situated within the grid. The corridors also fit within this grid. The more collective and additional functions are more freely placed within the grid. The height of most storeys is 4.8 or 3.1 metre.

The structure of the building consists of loadbearing brick facades, with a thickness of 600 mm. The structure inside the building consists of loadbearing inner walls and columns made of steel and concrete. In the building, five different floor types are used: brick floor (only in the basement), concrete floor, wooden floor, granite floor (only on the ground floor in the entrance zone of the building) and steel floor (only used for decks along the courtyards).

PROGRAM

Public functions are situated throughout the whole building, therefore the public functions can be typed as 'through'. The building is situated around two courtyards and consists of a semi-sunken basement, ground floor and two residential levels. There are two courtyards, one collective courtyard only meant for the residents and employers and employees of the building and one public courtyard. This public courtyard does have an open connection to the streets and also the restaurant is located along one side of the public courtyard.

The private realm of the dwellings is mainly placed in the top of the building on the first and second floor. There are also studio-dwellings and guesthouses placed on the ground floor. In total there are 20 dwellings, 8 studio-dwellings and 10 guesthouses. The dwellings can be typed as lofts of one or two storeys height with a mezzanine and maisonettes of 2 or more storeys height with also sometimes a mezzanine.

The closer you get to the base and the middle wing of the building, the more public the spaces become. Part of the collective realm is the circulation system, which gives access to the private dwellings for multiple dwellers. Ateliers, offices and spaces for creative businesses are also part of the collective realm, because they are situated along a collective corridor. The first and second floor contain ateliers and spaces for creative businesses on the north and east side and offices on the south side. The auditorium is located behind the northern facade. The south-western part of the basement is entirely intended for the catering industry. As a result, the collective space is situated throughout the whole building. The public realm is mainly situated in the basement and on the ground floor and in the middle of the building on the first and second floor.

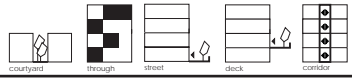

COURTYARD BUILDINGS

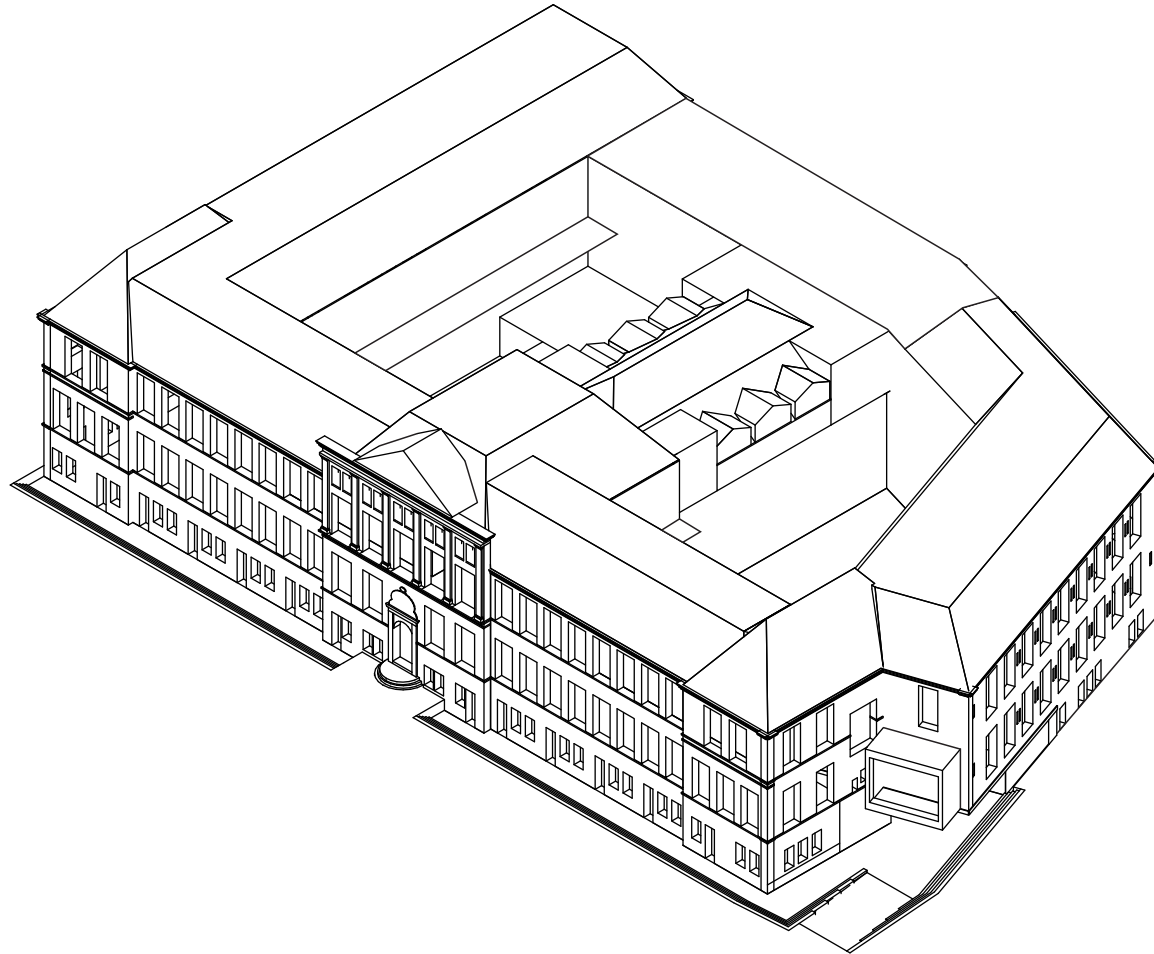

Facade scale 1:500 (own illustration)

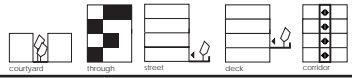

COURTYARD BUILDINGS

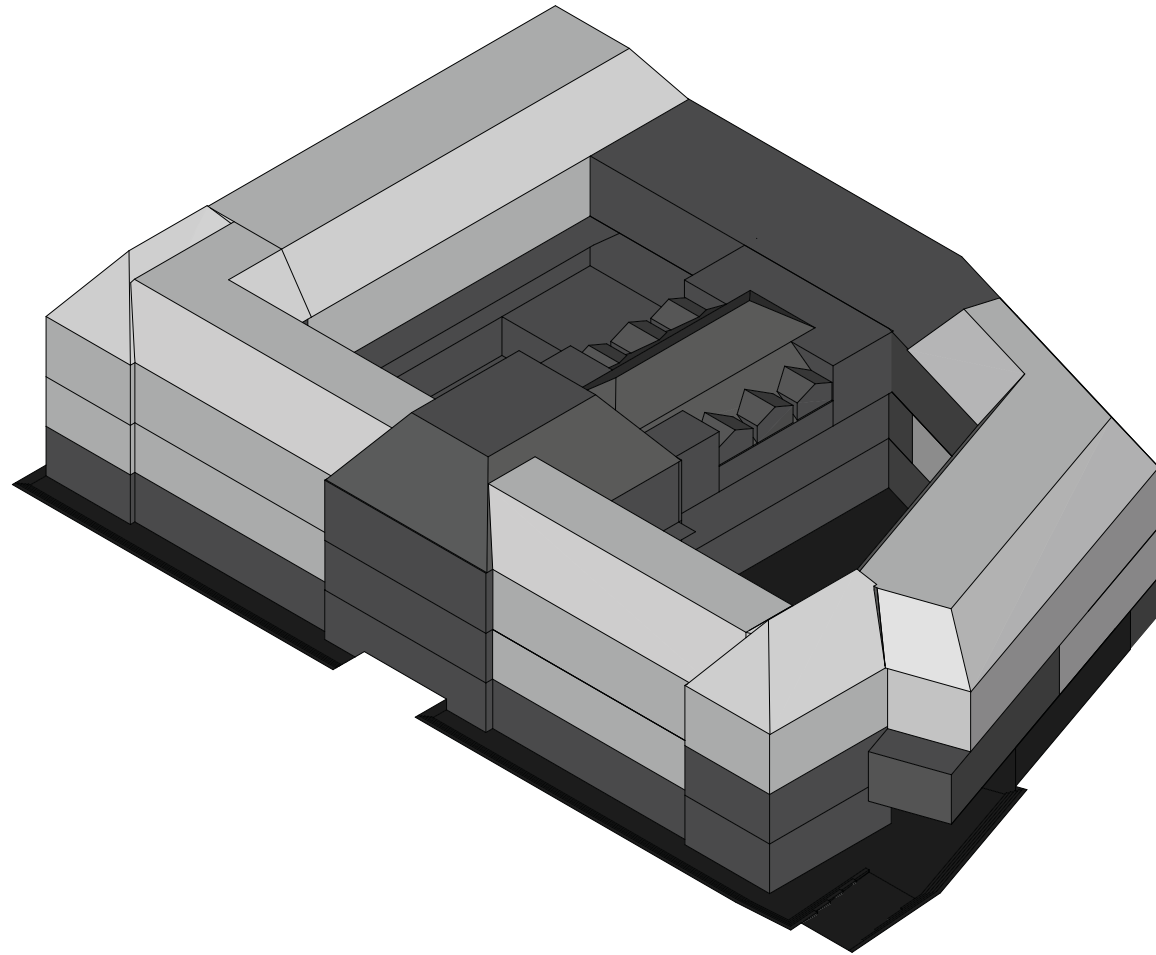

Public, collective, private scale 1:500 (own illustration)

CONTENT

public

collective

private

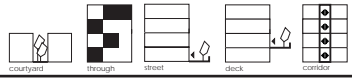

COURTYARD BUILDINGS

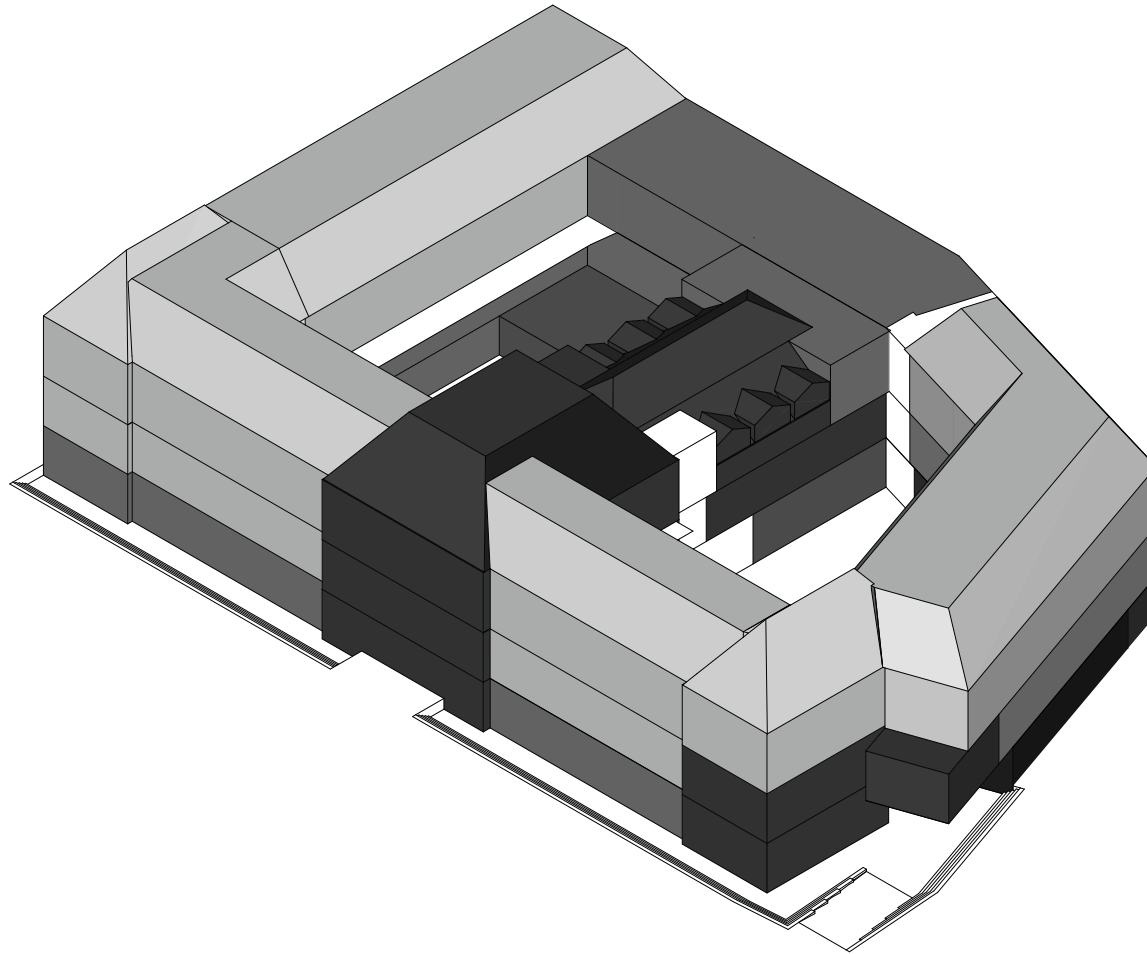

Program scale 1:500 (own illustration)

CONTENT

- | | | |
|---|--|---|
|  catering |  offices |  guesthouses |
|  creative businesses |  ateliers |  dwellings |

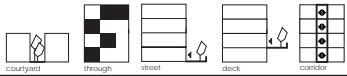

COURTYARD BUILDINGS

FACADE + MATERIALS

As already has been explained, the facade of the building is made of brick masonry with a depth of 60 centimetres. The courtyard building is characterized by a tight grid of windows. The windows are almost the same height as the ceiling height. The roof of the building is characterised by dormers and roof windows.

The materials which are used in this building are brick, steel, wood, granite and concrete. The facades are made of brick masonry with wooden window frames. The floors are made of brick, wood, granite and concrete and the new made decks along the courtyards are made out of steel.

CIRCULATION

The circulation is a mix of three different typologies, street, corridor and deck.

The building can be entered via a stairwell in the east and south part of the building. A part of the ateliers in the basement is accessible via a corridor and the other part is accessible via the street and the courtyard. The catering, offices and residential studios are also accessible via street and the courtyard.

Furthermore, the maisonettes on the first floor are approachable via deck, which is situated along the courtyards. These public and more private courtyards of the building are of a big influence on the private realm of the dwelling, because the collective decks, which give access to the dwelling, are situated within these courtyards. This results in a visual relation between the collective and the public, but also a more physical one, because people can also talk to each other and hand things over. It is almost as having your front door on a public street, due to the front doors of the dwellings, which are directly linked to the public realm. Since the public can not directly look into the dwelling, it does not lack privacy.

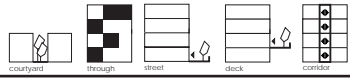

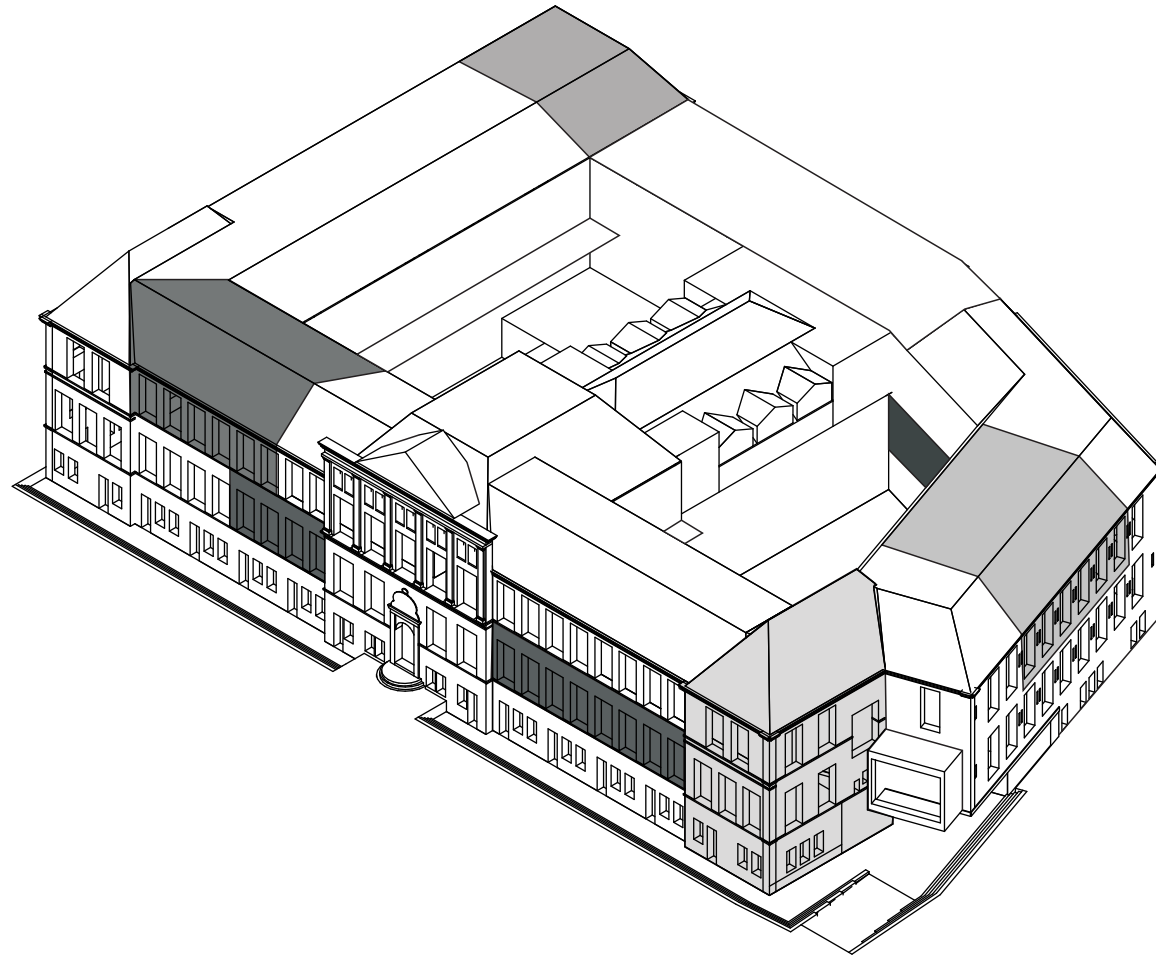

COURTYARD BUILDINGS







Dwelling configuration scale 1:500 (own illustration)

DWELLING WITHIN THE NEW HISTORY | COURTYARD BUILDINGS

CONTENT

-  loft type 1
-  loft type 2

-  loft type 3
-  maisonette type 1

-  maisonette type 2
-  maisonette type 3

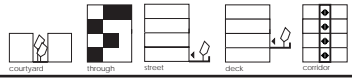

COURTYARD BUILDINGS



Ground floor

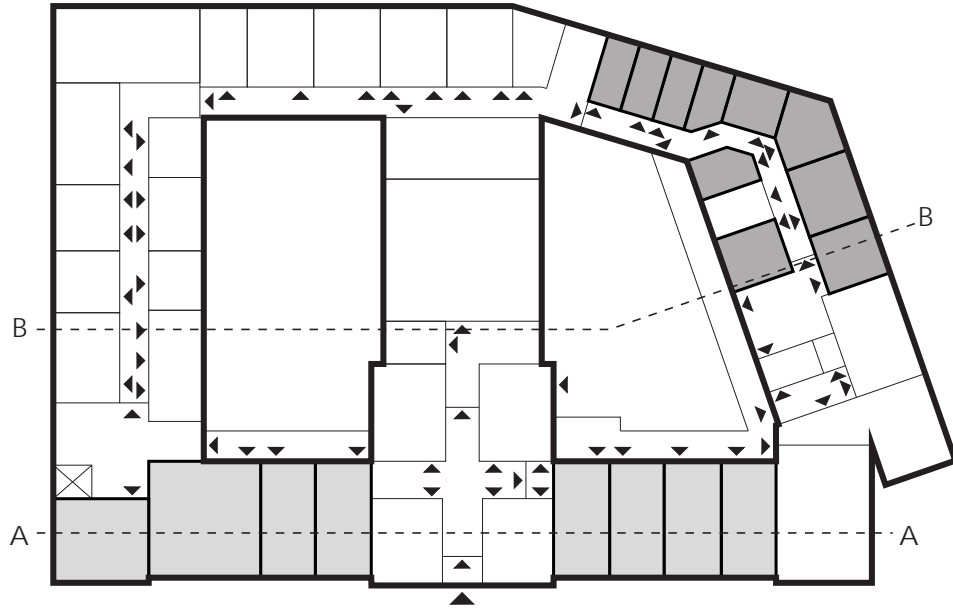

First floor

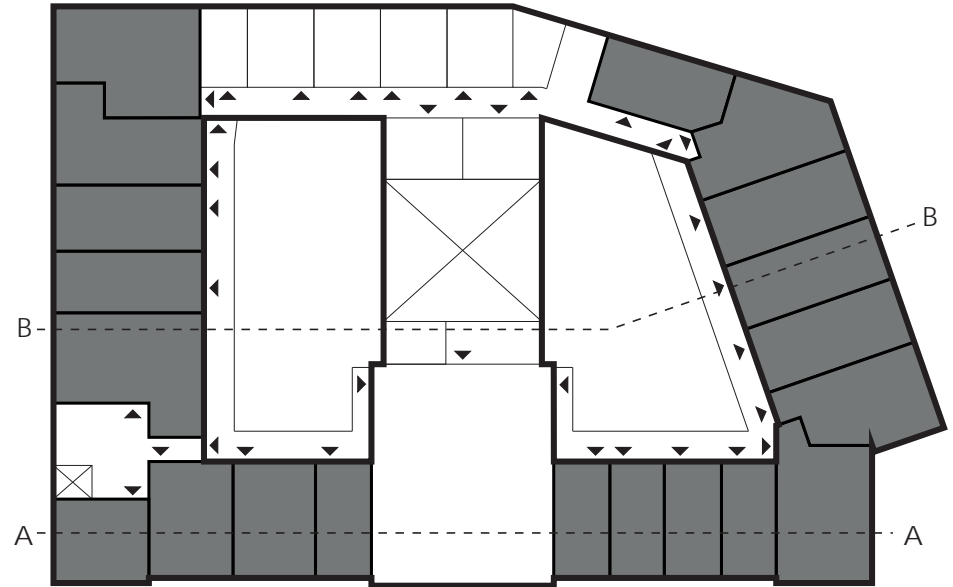

Longitudinal section A

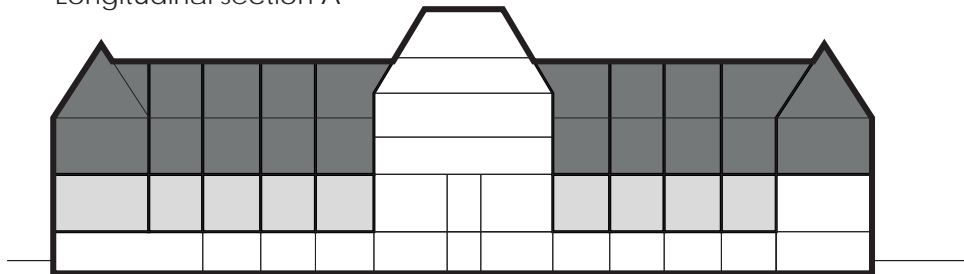

Longitudinal section B

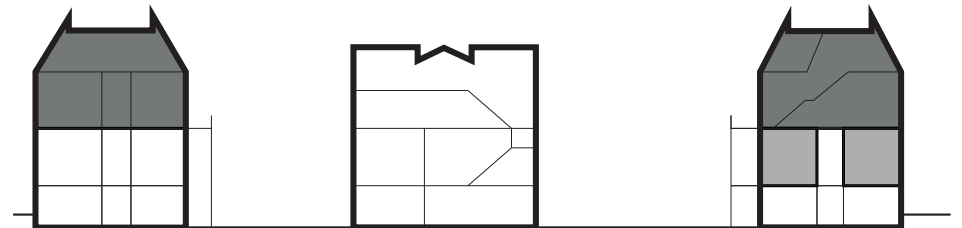

Dwelling typologies 1 (own illustration)

CONTENT

□ guesthouses

■ studio-dwellings

■ dwellings

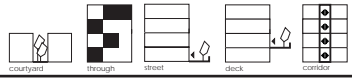

COURTYARD BUILDINGS



Ground floor

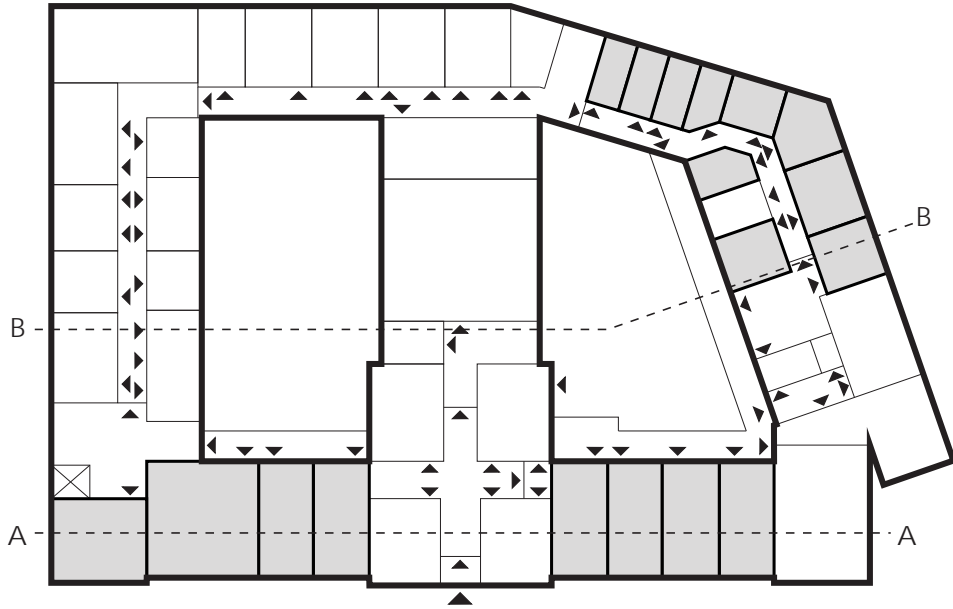

First floor

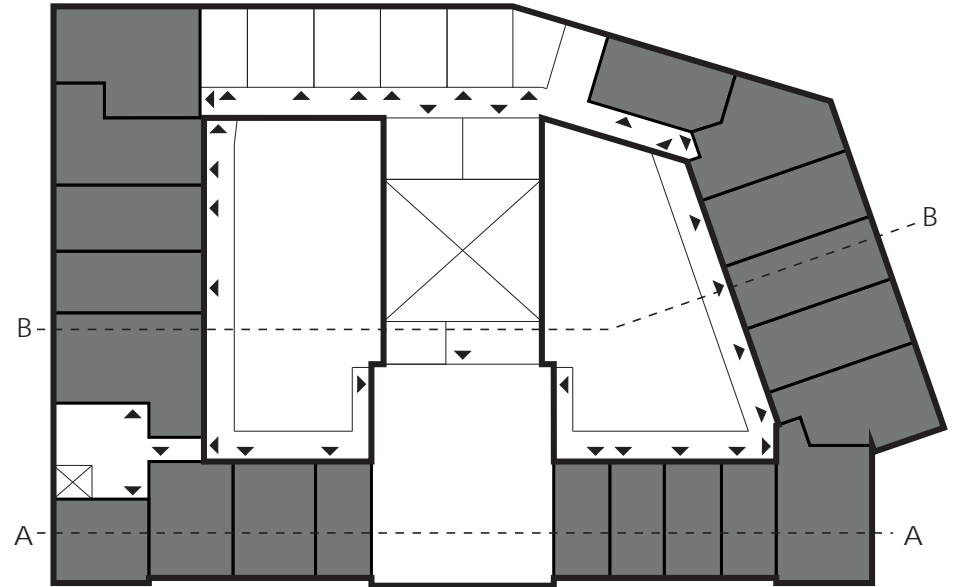

Longitudinal section A

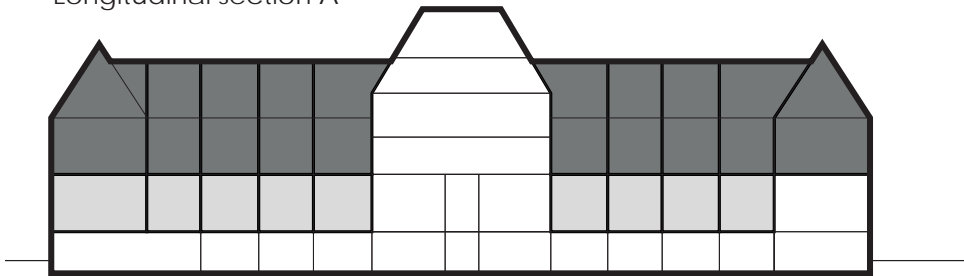

Longitudinal section B

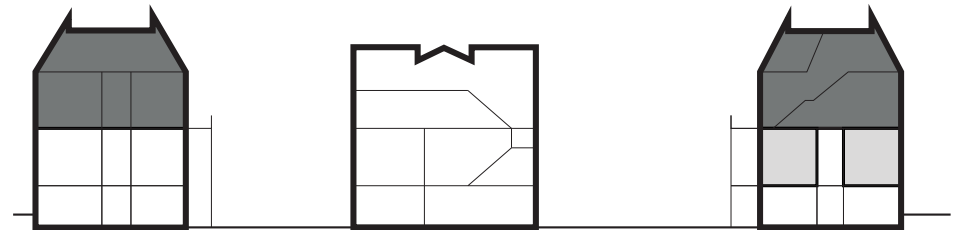

Dwelling typologies 2 (own illustration)

CONTENT
 lofts

maisonnettes



COURTYARD BUILDINGS

The Paleis building consists of 28 dwellings and 10 guesthouses. These dwellings can be divided into three main types of lofts and three main types of maisonettes. Not every dwelling has its own private outside space, but these inhabitants can use the deck and the courtyard as their outside space.

These different dwelling typologies will be described here.

LOFT TYPE 1

The first loft type that will be discussed is one of the guesthouses. The drawn guesthouse is meant for one person. In the building, there are also guesthouses for two and four persons. This loft type is one not so big open space with a service area on one side of the room. The space, which is left after the placing of this service area, is used in the most efficient way by a folding bed or a raised bed with a desk underneath. The guest, who stays in this room, can use his room for living, working and sleeping, therefore this dwelling type can be described as 'live-work with'. The guesthouses are all on the ground floor and they do not have a private outside space. The guesthouses can use the public courtyard as their outside space.

LOFT TYPE 2

The second loft type in this building is one big open space with a service area placed in the corner of the room. The placing of this service area divides the room into two different zones: one entrance zone with a more private character and one working zone with a more public character. The entrance of three of those dwellings is placed along the public courtyard and the entrance of two dwellings is placed along the private courtyard. A mezzanine with the functions living and sleeping is placed above this entrance zone. There is an open connection between the functions of the mezzanine and the working area, therefore this dwelling can be defined as 'live-work with'. This dwelling has no private outside space and therefore the inhabitants can use both the public and the private courtyard of the building as their outside space.

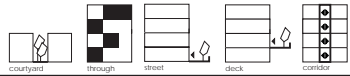

COURTYARD BUILDINGS

LOFT TYPE 3

The last type of loft that will be discussed in this research is one big open space on two floors with a mezzanine. This unit can be freely divided into different areas with different functions due to the fact that even the service area is not fixed in this dwelling. The shaft for all the ducts is placed on one side of the dwelling and all the ducts can be taken from here. This loft contains living and sleeping zones and the inhabitants of this unit can use a working area in the building. This dwelling unit can be defined as 'living-work nearby'.

In this analysis we have chosen an example of a working area, which can be used by this dwelling, but it is possible that the inhabitants use another working area in the building. This dwelling does not have a private outside space, but the deck and both of the courtyards can be used as the outside space of the dwelling.

Due to the fact that this dwelling can be freely arranged, this dwelling unit can also contain both living and working functions in this unit. The working zone can be placed on the lowest level and the living and sleeping zones on the upper floor and the mezzanine. Living is then the most important function, and therefore this unit can be defined as 'live-work with'. This unit

can also be defined as 'work-live near', when working is the main function in the unit, which takes place on the lowest floor and the mezzanine, and the upper floor is used for living and sleeping. This unit can even be defined as 'home occupation' when a room in the unit is used for working, which is not nearby the entrance, and the main function of the unit is living.



COURTYARD BUILDINGS

MAISONETTE TYPE 1

The first maisonette type is a corner dwelling, which contains three storeys. The entrance of this dwelling, which is on the lowest floor, gives direct access to the living space. The mezzanine can be used as a working zone and the upper floor is used for sleeping. The dwelling unit has two different staircases, one leads to the mezzanine and one to the upper floor. There is not connection between the mezzanine and the upper floor. This dwelling unit can be defined as 'home occupation' due to the fact that working is a separate room and it is not situated nearby the entrance.

The outside space of this dwelling unit is a roof terrace, which is situated next to the sleeping area of the unit. This roof terrace does not have a privacy issue, because on this level there are only two roof terraces which are located quite far from each other.

The maisonette is now defined as 'home occupation', but it can also be defined as 'work-live near', when the lowest floor and the mezzanine are used for working and the upper floor for living and sleeping. In this case the floor for living and sleeping is rather small. This unit can also be described as 'live-work nearby' when the unit is only used only for living and sleeping and the inhabitant uses a separate room in the building for working activities.

MAISONETTE TYPE 2

The second maisonette type is repeated a couple of times in the building and contains three storeys. The entrance of this dwelling, which is on the lowest floor, gives direct access to the living space. The mezzanine can be used as a working zone and the upper floor is used for sleeping. This dwelling unit can be defined as 'home occupation' due to the fact that working is a separate room and it is not situated nearby the entrance.

The upper floor can be used for sleeping and a separate staircase gives from this level access to the roof terrace, which is situated on top of the sleeping floor. The roof terrace is only on half of the roof of the dwelling. The roof terrace is sunken in the roof and the walls along the roof terrace are one meter high. The roof terraces have a privacy issue, because neighbours can look into each others private outside spaces. But this is partly solved by the distance between the different outside spaces.

This maisonette type is now defined as 'home occupation', but it can also be defined as 'work-live near' and 'live-work nearby' as already is explained with the maisonette type 1.



COURTYARD BUILDINGS

MAISONETTE TYPE 3

The last maisonette is also a corner unit of four storeys. The lowest two floors are used for working activities. The lowest working area is located in the basement and is accessible via the courtyard and the street. The working area on the ground floor is accessible via a stair on the first floor. The living area, which is double high is located on the first floor and has a separated entrance then the working zone on the ground floor. The upper floor is used for sleeping. This dwelling unit does not have its own private outside space and it can use the deck and the public courtyard as its outside space.

In this dwelling unit is working the most important function, and that is why this unit can be called a 'work-live near' unit. This unit can also split up in two or three different units that function separately from each other. It can be split up in: a working unit of two storeys and a dwelling unit of two storeys; a working unit of one storey and a live-work unit of three storeys; and two working units of one storey and a dwelling unit of two storeys.

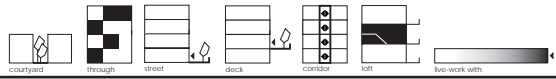

COURTYARD BUILDINGS

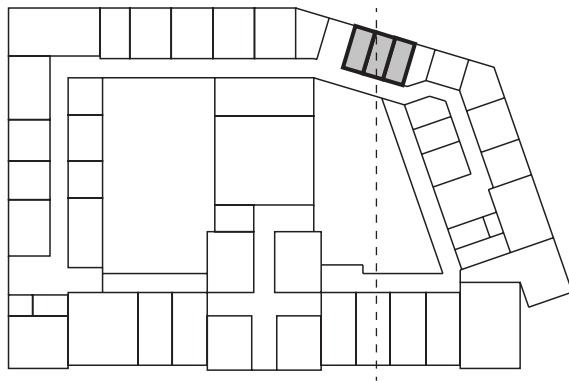

Ground floor



Section



LIVING/SLEEPING/WORKING

Loft type 1 floorplans and sections scale 1:1000 & 1:150 (own illustration)

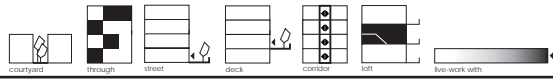

COURTYARD BUILDINGS

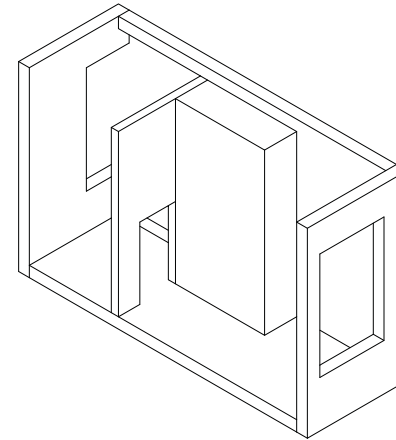
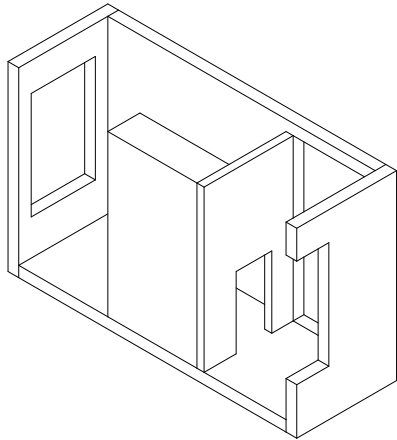

Loft type 1 axonometry scale 1:150 (own illustration)

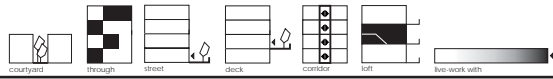

COURTYARD BUILDINGS

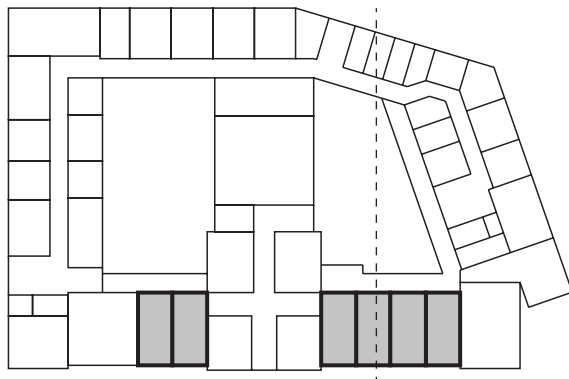

Ground floor



Section

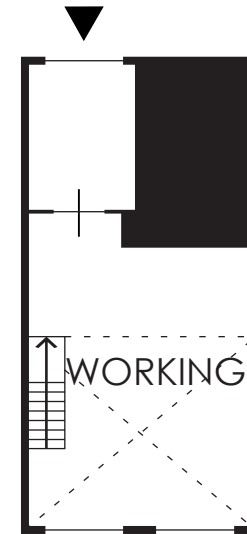

Loft type 2 floorplans and sections scale 1:1000 & 1:150 (own illustration)

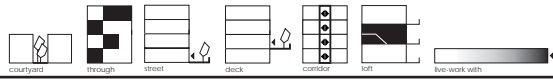

COURTYARD BUILDINGS

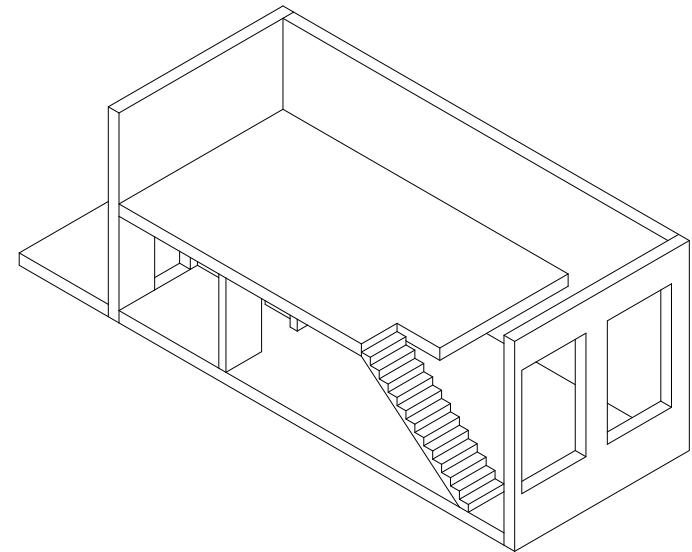
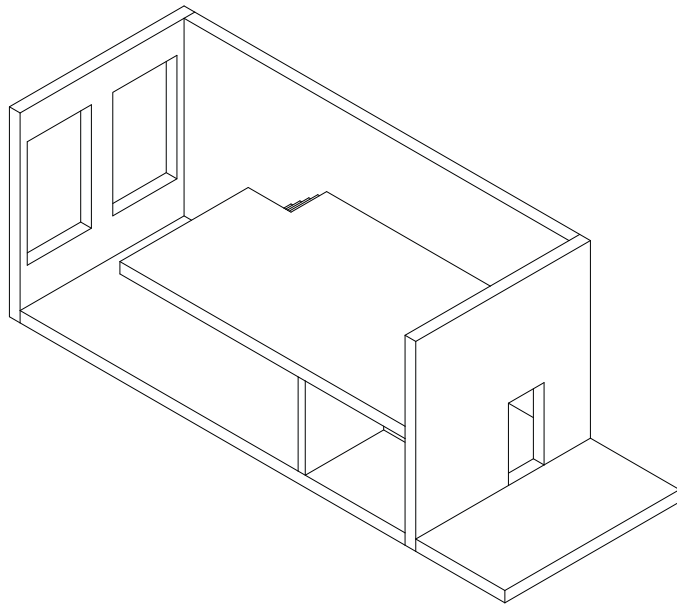

Loft type 2 axonometry scale 1:150 (own illustration)

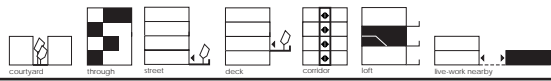

COURTYARD BUILDINGS

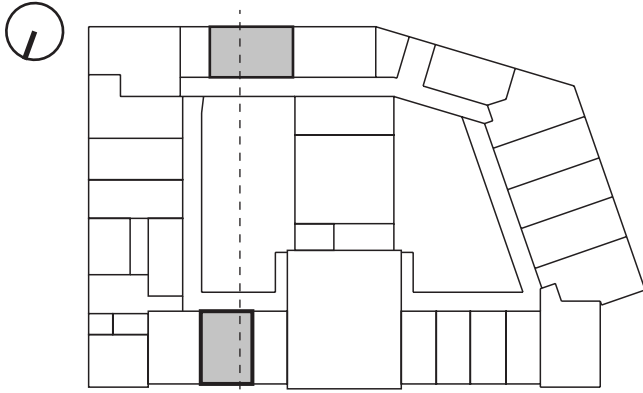

First floor



Section

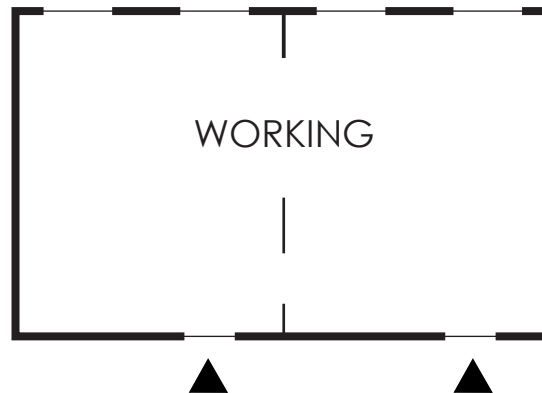
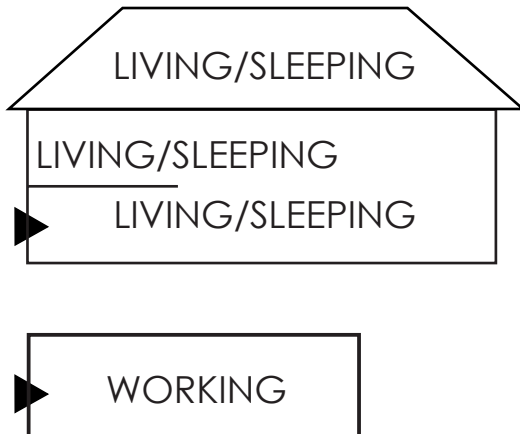
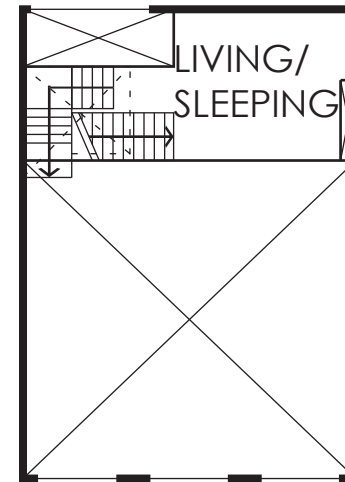
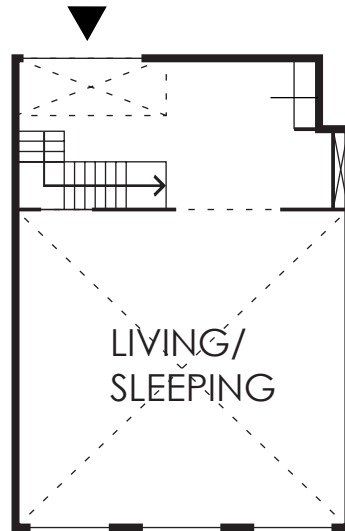

Loft type 3 floorplans and sections scale 1:1000 & 1:150 (own illustration)

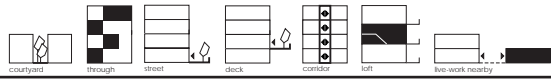

COURTYARD BUILDINGS

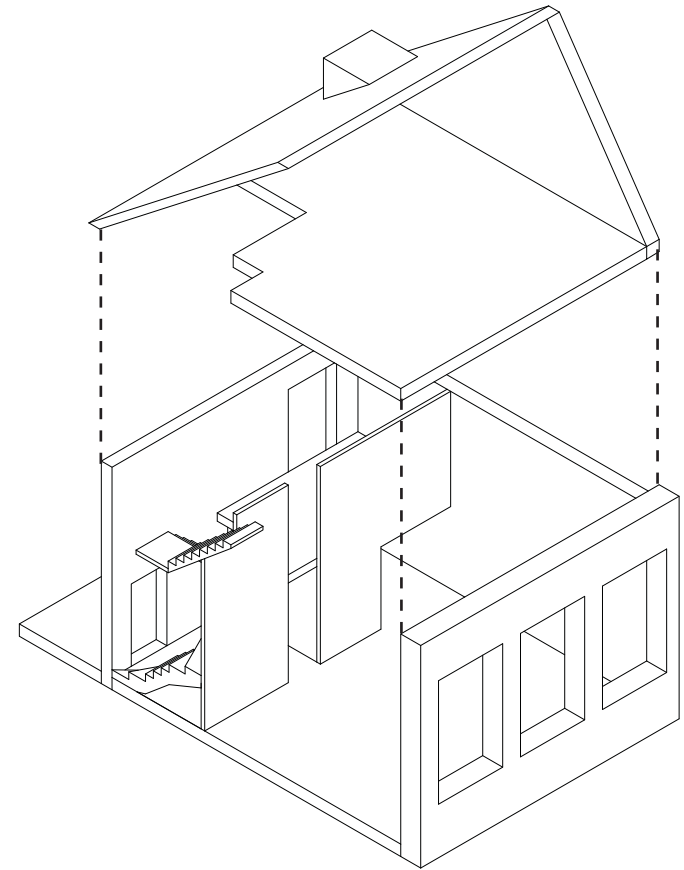
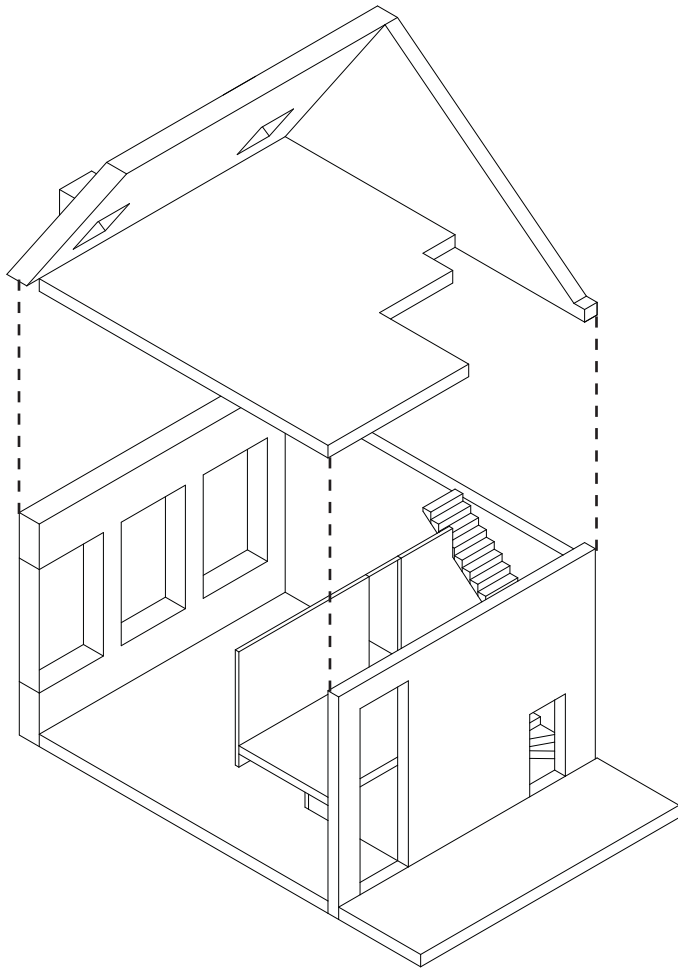

Loft type 3 axonometry scale 1:150 (own illustration)

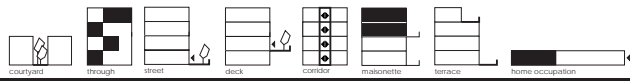

COURTYARD BUILDINGS

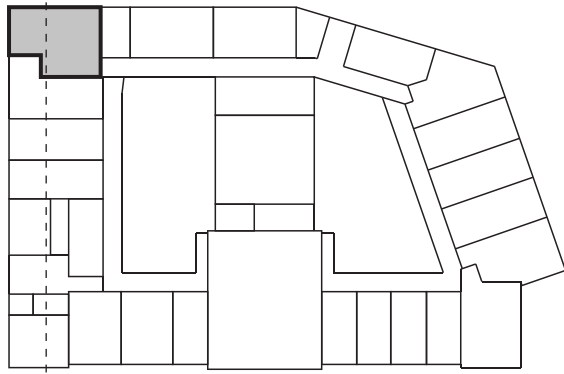

First floor

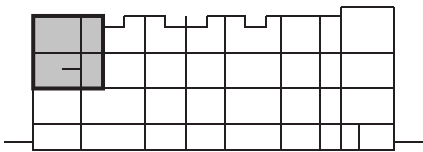

Section

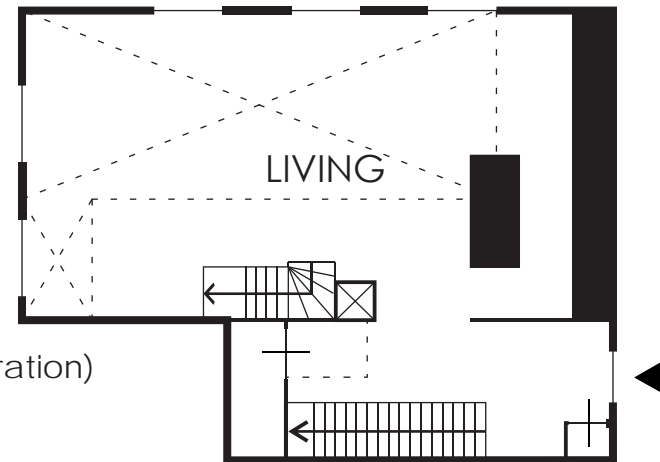
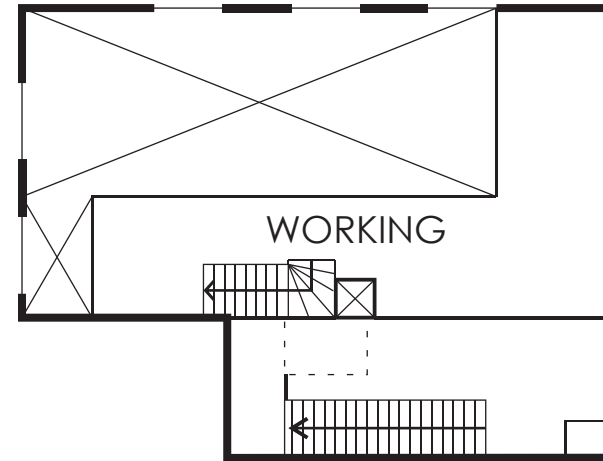
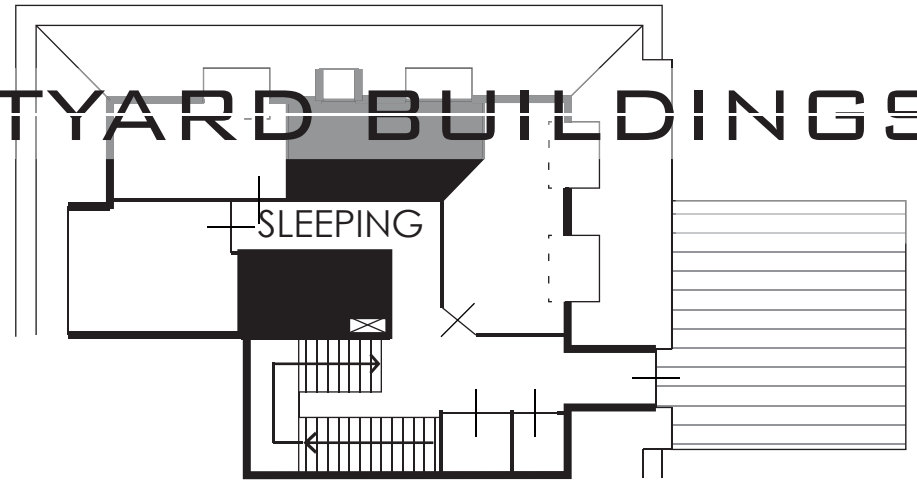
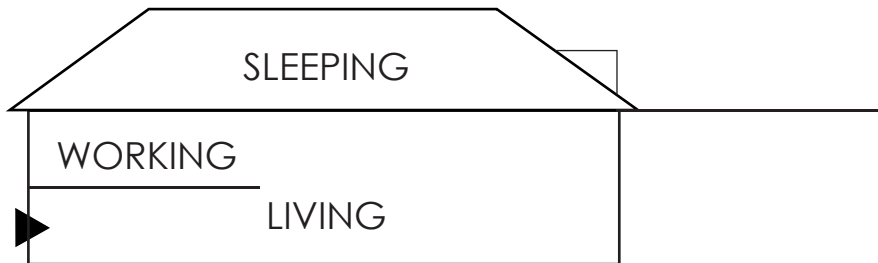

Maisonette type 1 floorplans and sections scale 1:1000 & 1:150 (own illustration)

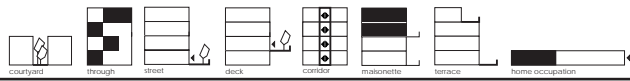

COURTYARD BUILDINGS

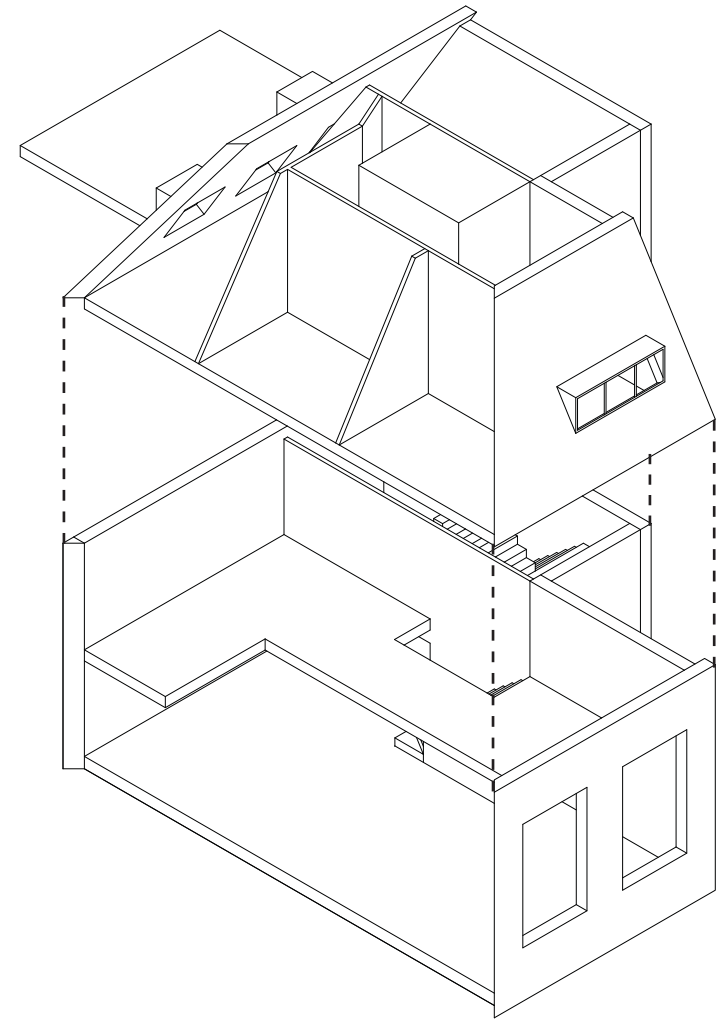
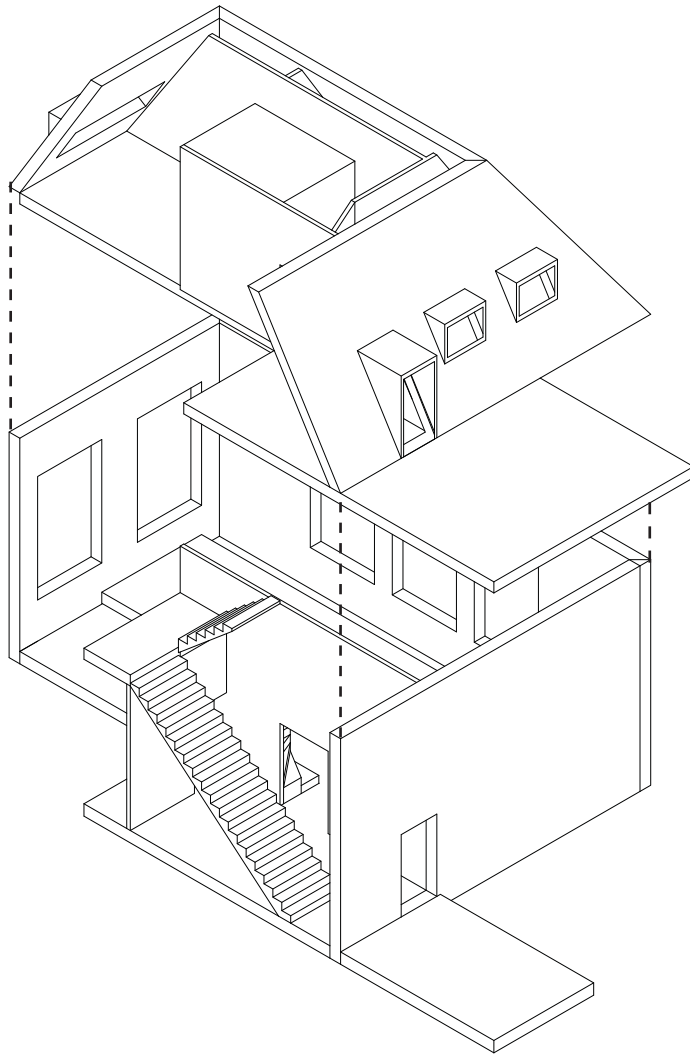

Maisonette type 1 axonometry scale 1:150 (own illustration)

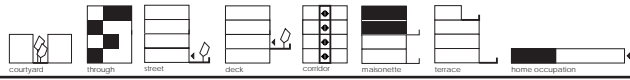

COURTYARD BUILDINGS

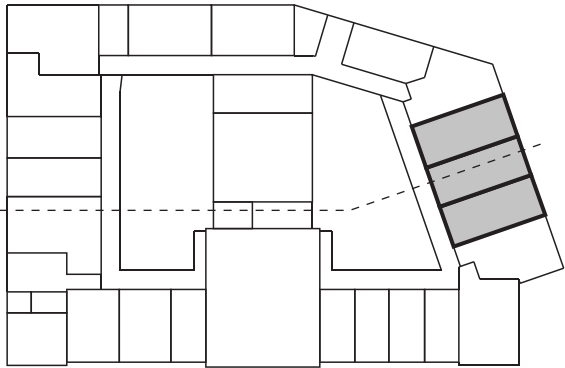

First floor

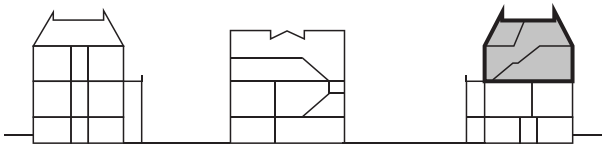

Section

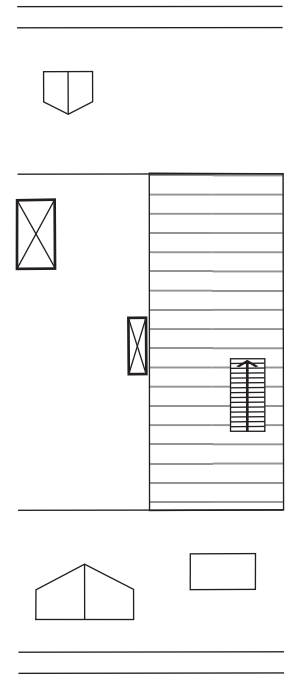
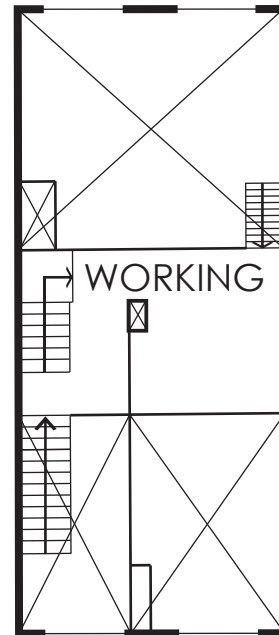
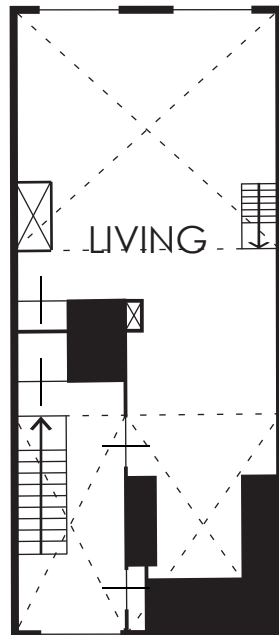
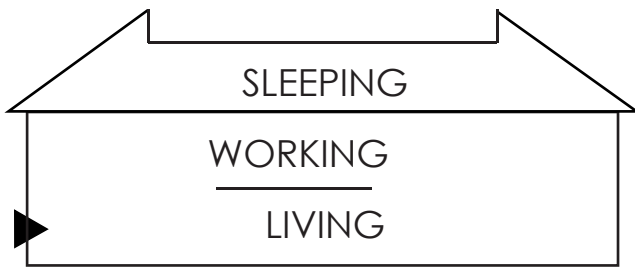

Maisonette type 2 floorplans and sections scale 1:1000 & 1:150 (own illustration)

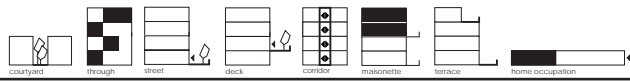

COURTYARD BUILDINGS

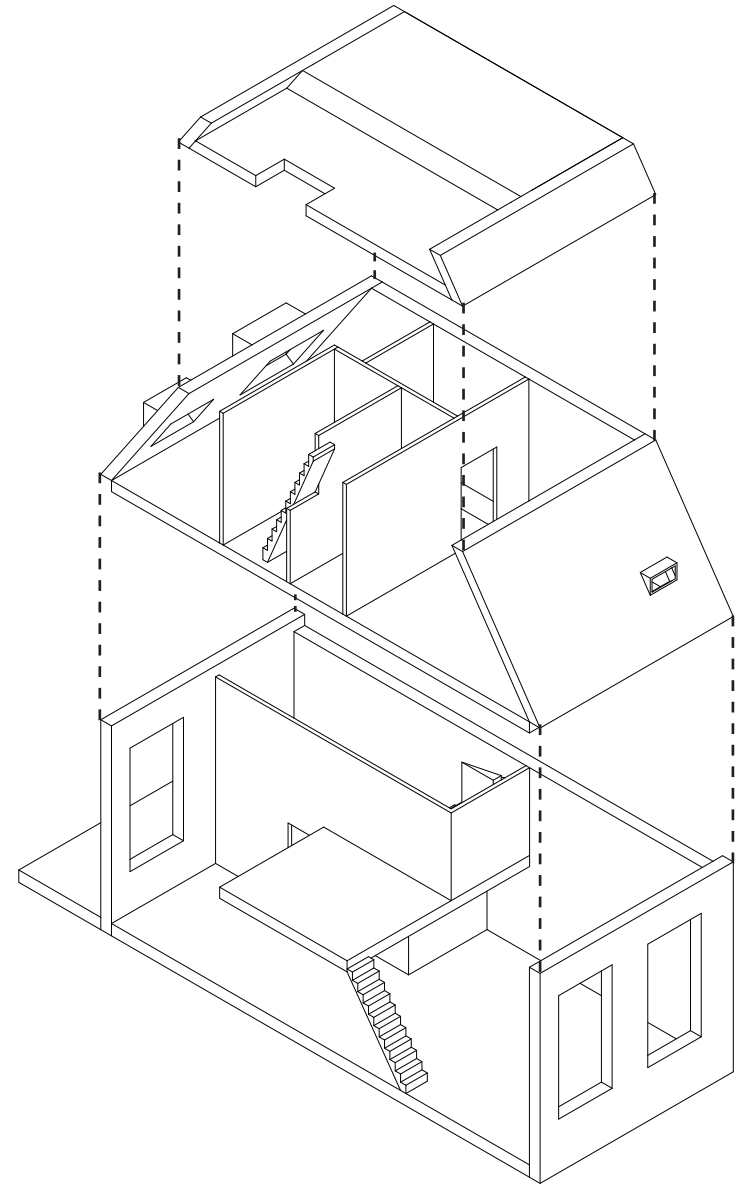
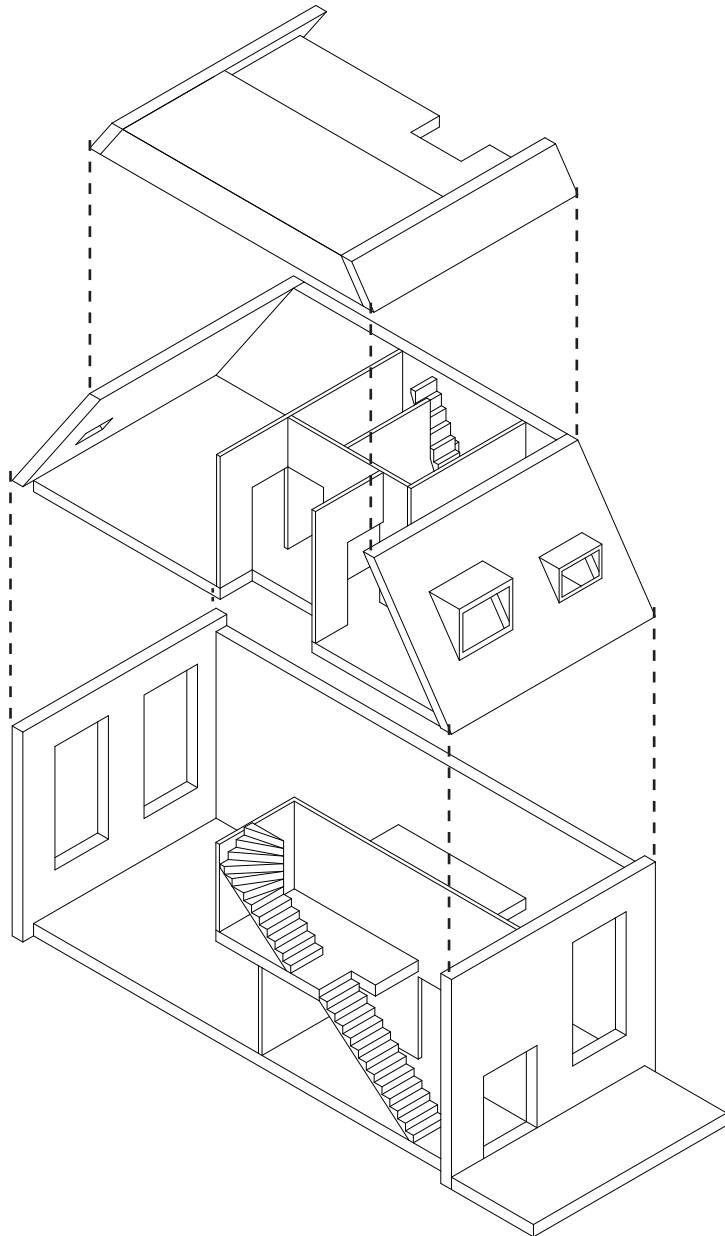

Maisonette type 2 axonometry scale 1:150 (own illustration)

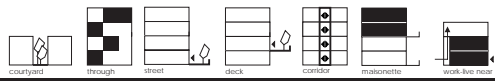

COURTYARD BUILDINGS

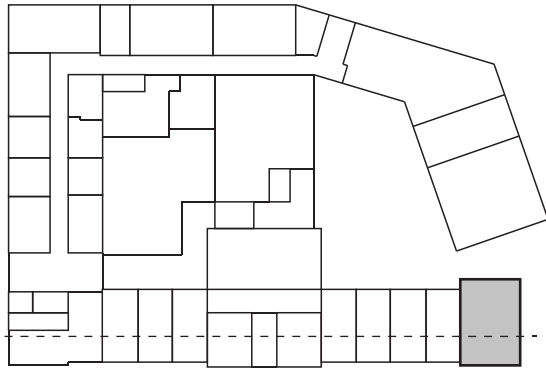

Basement

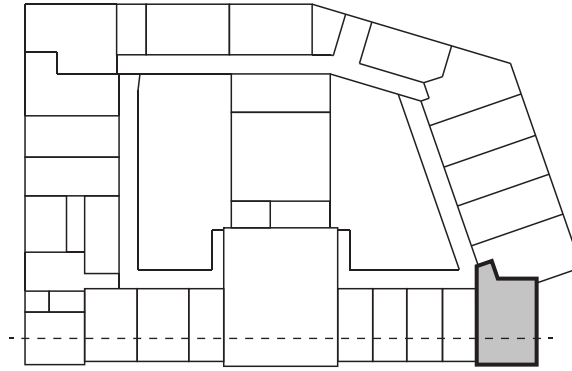

First floor

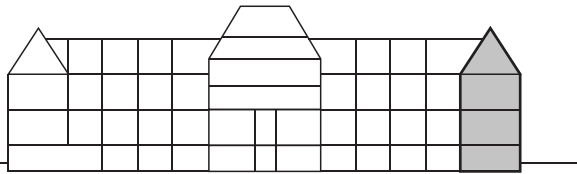

Section

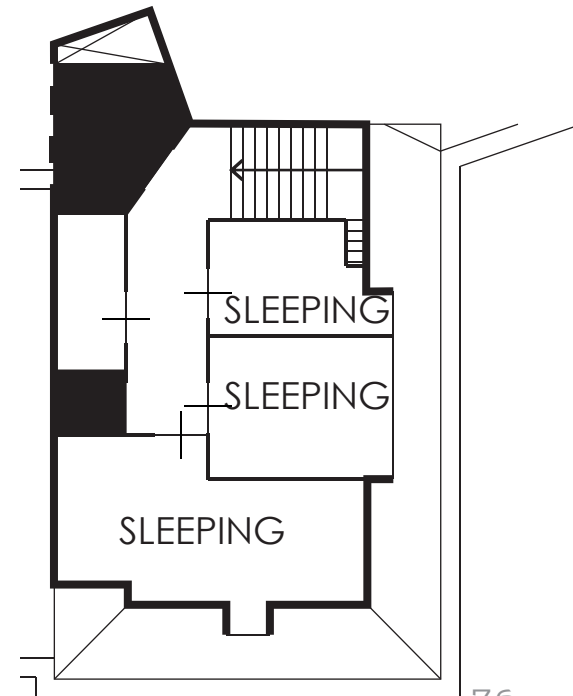
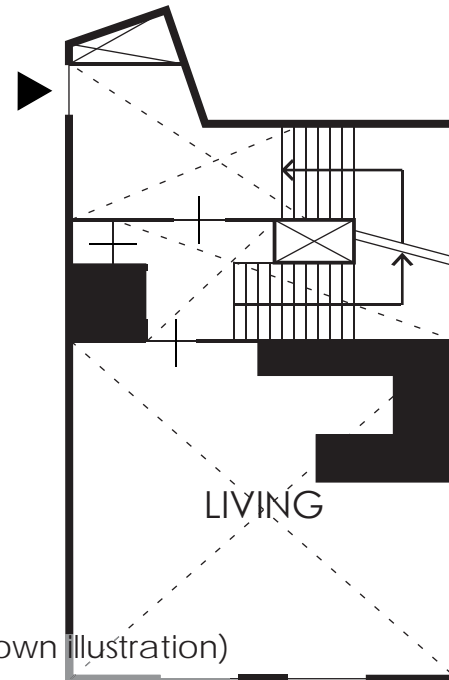
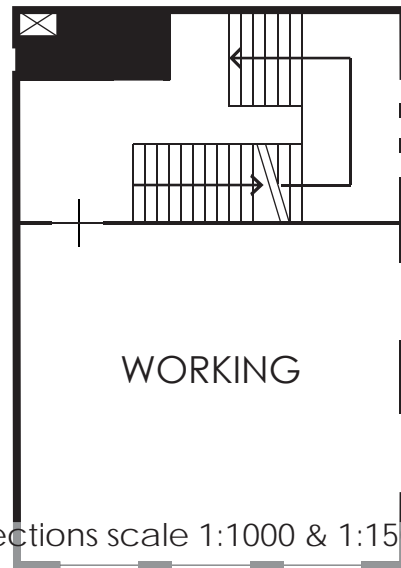
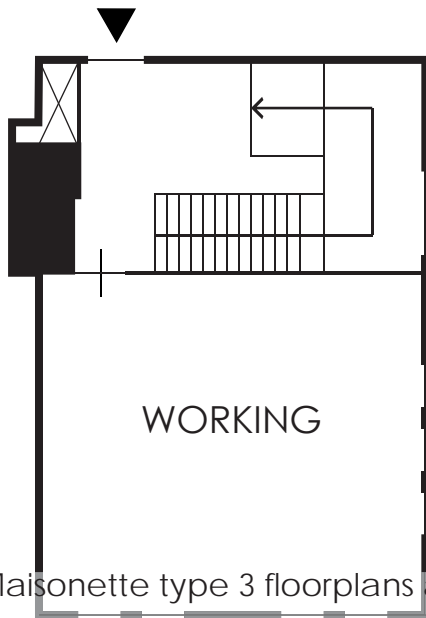
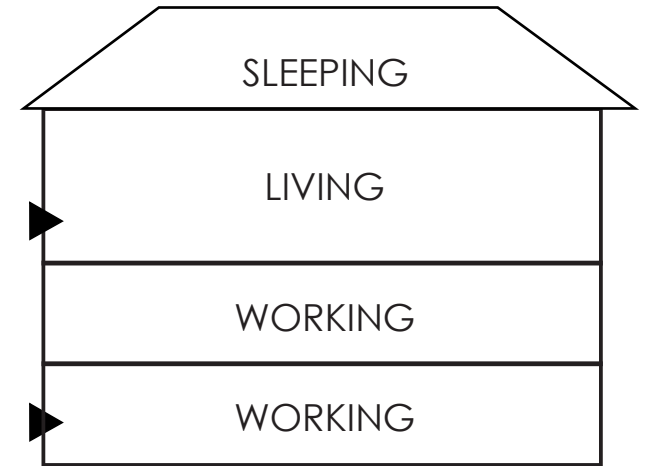

Maisonette type 3 floorplans and sections scale 1:1000 & 1:150 (own illustration)

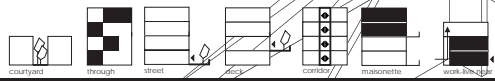

COURTYARD BUILDINGS

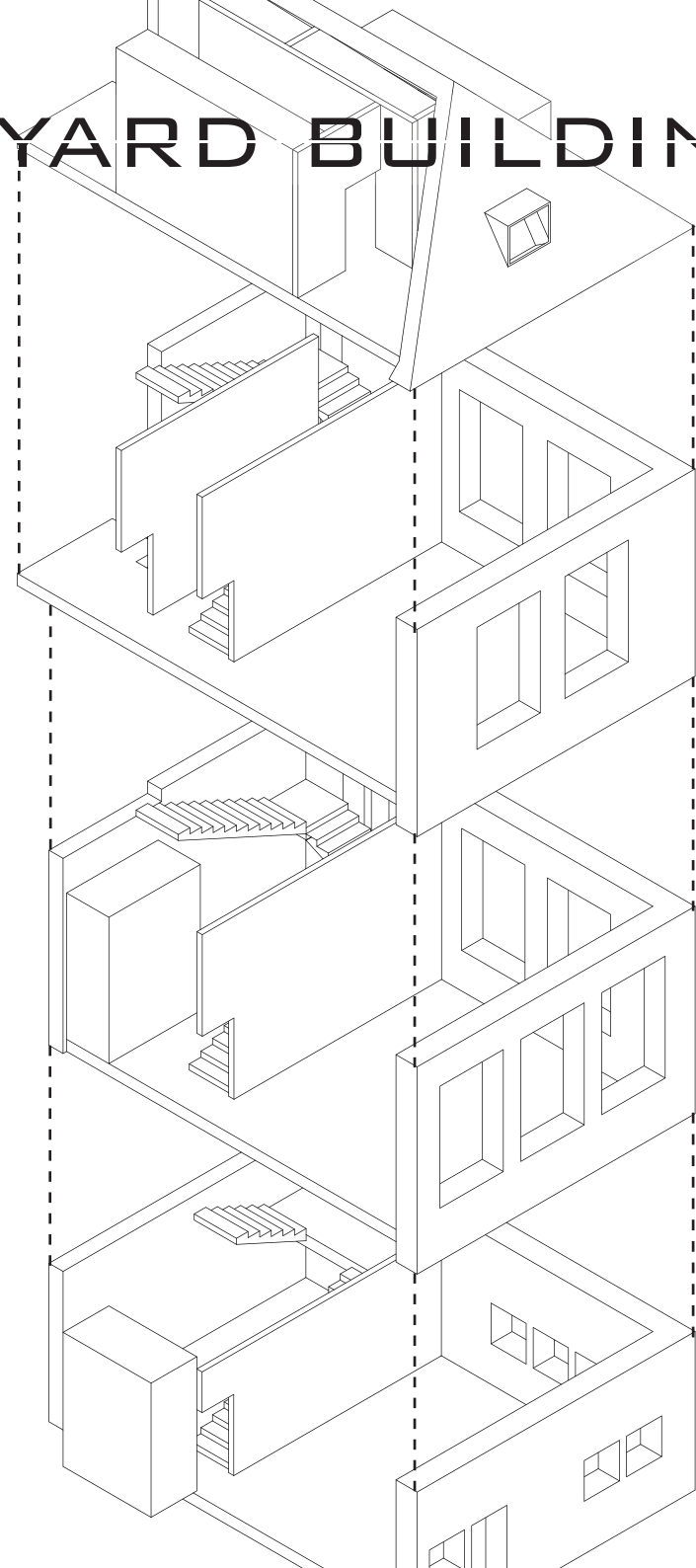
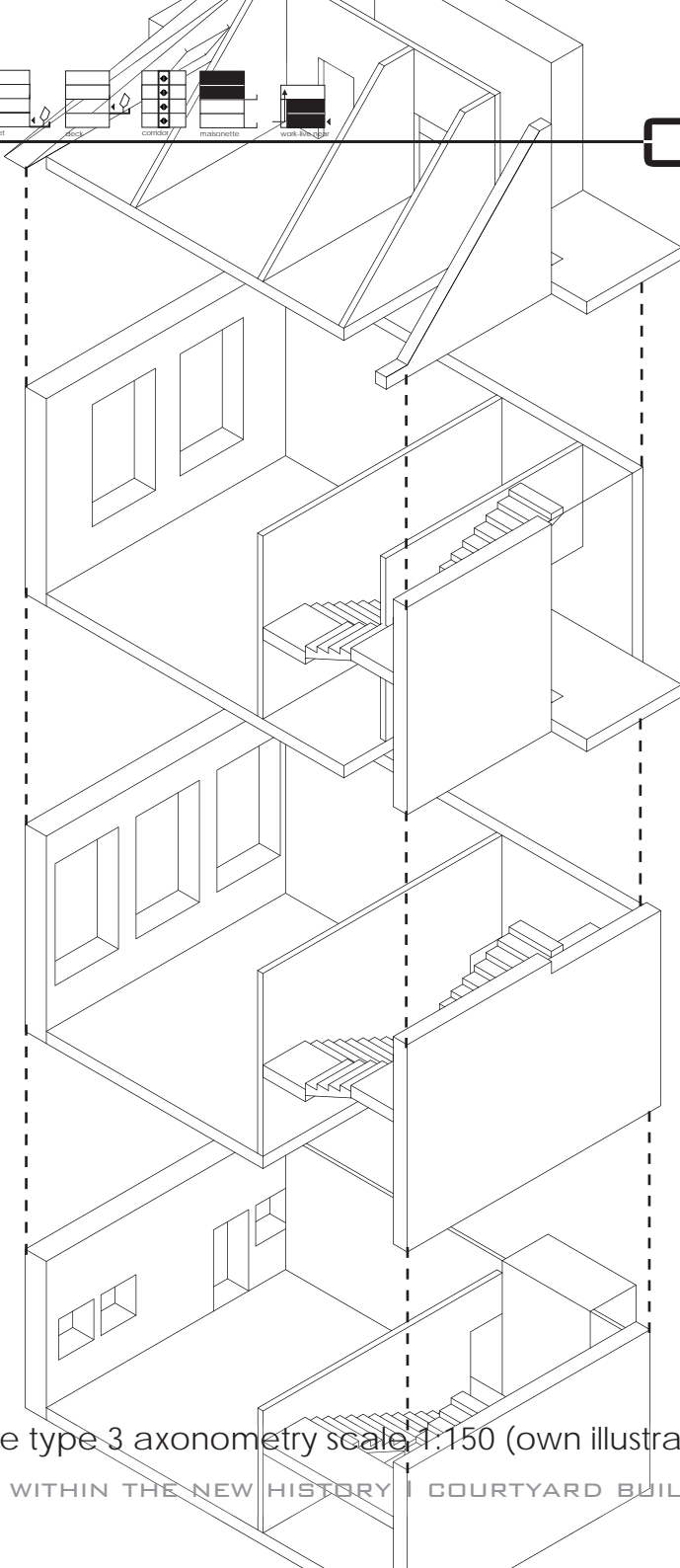

Maisonette type 3 axonometry scale 1:150 (own illustration)

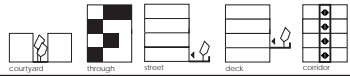

COURTYARD BUILDINGS

DAYLIGHT

The dwellings have direct daylight all day, because all dwellings are orientated on two sides. Also the dwellings are not very deep; up to 11.2 meter. This, in combination with the large windows (3 meters high) and mezzanines which are placed a little back from the window, leads to very comfortable dwellings, in terms of daylight penetration.

INTERIOR

The interior of all the dwellings contain structural elements of the old building. These structural elements are the brick masonry facades and the concrete beams. These beams divide the room in different parts. Besides that, these structural elements characterize the dwellings in this building, as can be seen in the upper image. The other image shows how the open space of the dwelling unit is used and divided into different space.

OUTSIDE SPACE

Since the building is low and 8-shaped, it has the perfect shape for 2 courtyards. The eastern courtyard is collective and is freely accessible for everyone; the western courtyard is private and is only accessible for inhabitants. For the courtyards being freely accessible for everyone, it is not the perfect location for private outside spaces. The most appropriate side for outside spaces is thereby the south facade and the roof. For that reason this building has two enormous private roof terraces on the south side of the building and some other smaller private roof terraces on a higher level and more to the north of the building, though with orientations to the west and east. It is not possible to look directly from the courtyards into the roof tops, that is why these roof terraces have quite an amount of privacy. The privacy on the roof terraces is not a problem, because the roof terraces are not situated directly next to each other and the roof terraces are sunken in the roof, which results in a fence around the roof terrace of 1 meter height. There is a big distance and visual connection between the dwelling and its private outside space and the public courtyard. Thereby there is a big difference between the private realm of the dwelling and the public realm of the courtyard. Dwellers are therefore not forced to be social engaged.

One pity is that not all rooftop surfaces are used for outside spaces. This results in some dwellings without private outside space. Those people really need the decks and the more collective courtyards as their outside space. Those dwellers are forced to be social engaged.

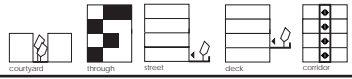

COURTYARD BUILDINGS

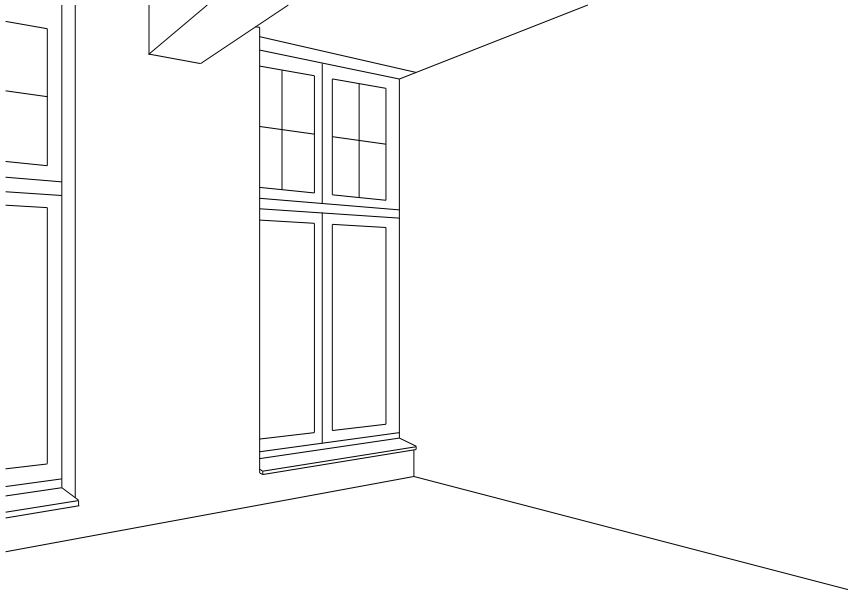

Perspective interior dwelling (own illustration), (Lambert Kamps Art & Design, S.D.)

COURTYARD BUILDINGS

CONCLUSION

Courtyard buildings can be divided into monasteries, barracks (which can be split up in barracks for military purposes and fire stations) and school buildings.

The most obvious characteristic of courtyard buildings is that one or more courtyards are realized within the building volume, which can be L-shaped, U-shaped, completely closed etc. Most of the courtyard buildings consist of a simple cellular structure, which makes them very easy to transform into other functions. This structure makes the building also very flexible. Most of the courtyard buildings do consist after the transformation of more than one function.

The facade of courtyard buildings is mostly characterized by brick masonry with a grid of windows.

Monasteries are characterized by a layout of different rooms, like simple private rooms, shared rooms, courtyards and a chapel. This makes it usually no problem to transform the building into a hotel restaurant, a convention center, an apartment building or a nursing home.

Most of the former fire stations which have been squatted are transformed into creative living-work spaces for artists. Vacant fire stations were also used by squatters for hosting large groups of sympathizers.

Many small school buildings have been transformed into residential buildings, whether or not in combination with workshops or other creative workspaces. Large room' sizes, high ceilings and good daylight penetration through big window openings characterize the interior of school buildings. This makes them very attractive as loft type dwellings for artists.

Large school buildings are mostly transformed into commercial functions or a mix of social functions whether or not combined with dwellings. These commercial functions are necessary to keep the renovation affordable.

There are three standard building volumes for courtyard buildings, it is difficult to define specific/standard typologies for additional functions, circulation, outside spaces, dwelling and work-live. The typologies in courtyard building are too diverse to be able to mention the standard typology, that is why the diagram on the shows all the possible typologies.

COURTYARD BUILDINGS

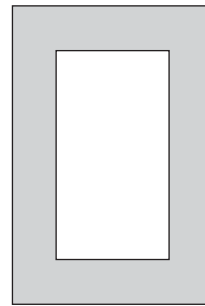

Closed building

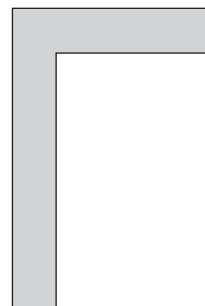

L-shaped building

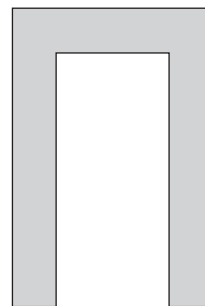

U-shaped building



in the base



next to



through

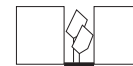

courtyard

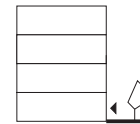

street

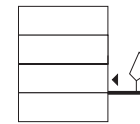

deck

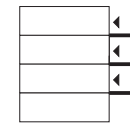

gallery

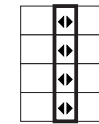

corridor

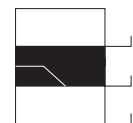

loft



maisonette

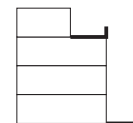

terrace

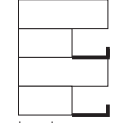

loggia



balcony



live-work with



live-work near



live-work nearby

Conclusion courtyard buildings (own illustration)

FOOTNOTES

1. HENDRIKX, S. 2008. *Kloosters als religieus erfgoed. Bouwstenen voor een te voeren beleid*, Utrecht, Uitgeverij Matrijs, (p. 9).
2. Ibidem (p. 10).
3. Ibidem (p. 49).
4. Ibidem (p. 11).
5. Ibidem (p. 13).
6. Ibidem (p. 17).
7. Ibidem (p. 48).
8. Ibidem (pp. 48-49).
9. Ibidem (p. 49).
10. Ibidem (p. 51).
11. KALK, E. 2010. *Nieuw leven voor meer gebouwen. Hergebruik kan sneller en beter*, Amsterdam, Stichting Agora Europa, (p. 61).
12. Ibidem (p. 62).
13. Ibidem (p. 62).
14. Ibidem (p. 63).
15. Ibidem (p. 63).
16. Ibidem (p. 63).
17. Ibidem (p. 63).
18. Ibidem (p. 90).
19. Ibidem (p. 91).
20. Ibidem (p. 92).
21. Ibidem (p. 93).
22. Ibidem (p. 93).
23. Ibidem (p. 95).
24. CANTACUZINO, S. 1989. *Re/Architecture. Old buildings/New uses*, London, Thames and Hudson, (p. 127).
25. KALK, E. 2010. *Nieuw leven voor meer gebouwen. Hergebruik kan sneller en beter*, Amsterdam, Stichting Agora Europa, (p. 92).
26. HENDRIKX, S. 2008. *Kloosters als religieus erfgoed. Bouwstenen voor een te voeren beleid*, Utrecht, Uitgeverij Matrijs, (p. 29).
27. KALK, E. 2010. *Nieuw leven voor meer gebouwen. Hergebruik kan sneller en beter*, Amsterdam, Stichting Agora Europa, (p. 93).
28. CANTACUZINO, S. 1989. *Re/Architecture. Old buildings/New uses*, London, Thames and Hudson, (p. 127).
29. CANTACUZINO, S. 1975. *New uses for old buildings*, London, The Architectural Press Ltd, (p. 27).
30. Ibidem (p. 26).
31. HENDRIKX, S. 2008. *Kloosters als religieus erfgoed. Bouwstenen voor een te voeren beleid*, Utrecht, Uitgeverij Matrijs, (p. 16).
32. Ibidem (p. 48).
33. Ibidem (p. 35).
34. Ibidem (p. 35).
35. KALK, E. 2010. *Nieuw leven voor meer gebouwen. Hergebruik kan sneller en beter*, Amsterdam, Stichting Agora Europa, (p. 61).
36. Ibidem (p. 64).
37. Ibidem (p. 94).
38. Ibidem (p. 95).
39. SCHLIMBACH, J. 2008. *Kunstenaars zoeken chemie in Het Paleis. Dagblad van het Noorden*.
40. FLEXIMAP GRONINGEN. 2012. *Monumenten Het Paleis, vm. chemisch lab Bloemsingel 10* [Online]. Available: <http://fleximap.groningen.nl> [Accessed 8-12-2012].
41. SCHLIMBACH, J. 2008. *Kunstenaars zoeken chemie in Het Paleis. Dagblad van het Noorden*.
42. FLEXIMAP GRONINGEN. 2012. *Monumenten Het Paleis, vm. chemisch lab Bloemsingel 10* [Online]. Available: <http://fleximap.groningen.nl> [Accessed 8-12-2012].

WAREHOUSES



Tetterode in Amsterdam (Kalk, 2010, p. 42)



Tussen de bogen in Amsterdam (Kalk, 2010, p. 45)

HISTORY

Most of the warehouses, in the Netherlands, are built in the seventeenth century. The examples referred to in this paragraph are all situated in the city of Amsterdam. In the city, there are different types of warehouses built. The oldest, traditional type is logically situated within the city center; where merchants build their warehouses especially along or near the former waterfront of canals and harbours. These warehouses of 'handelscompagnieën' were often arranged in groups; hiding several warehouses behind one facade sometimes even four lots wide.¹

The last important step in the evolution of warehouses is the building of the grain silos at Westerdoksdijk along the Houthaven. This monumental building, designed by the architects Jacob Klinkhamer and A.L. Van Gendt is 105 meters long, 20 meters width and 30 meters high.²

In Great-Britain they started to re-use industrial buildings in the fifties and sixties.³ In the sixties and seventies, a lot of industrial buildings and warehouses in the Netherlands have lost their function due to the government policy, which was focused on the replacing of industrial activities from the inner cities to the outskirts of the city.⁴ These buildings became vacant due to changing requirements for transportation and fire safety.⁵ At the same time, the re-use of industrial buildings became important through the agency of squatters.⁶

In the early eighties, squatters started re-using the former type-foundry **Tetterode** as a live-work building.⁷ The final breakthrough for the valuation of industrial heritage by the general public took place in 1996, in the Year of the Industrial Heritage.⁸ Industrial heritage, built in a characteristic style, does not have to deal with the



Westergasfabriek in Amsterdam (Kalk, 2010, p. 43)

problems of vacancy according to the Old Map of the Netherlands. This is for example the case with the project 'Tussen de bogen'.⁹

The success of the re-use of the **Westergasfabriek** has led from the nineties to more support among the general public.¹⁰

The recent interest in the preservation and redevelopment of old industrial buildings and sites cannot be considered apart from wider economic and societal trends. One of these trends is that governmental policies realize a large part of the housing assignment within the boundaries of the city and no longer in the growth cores. Another trend is the arising of creative industries, which is a collective term for companies and institutions in arts, creative services and media & entertainment.¹¹

CHARACTERISTICS

Warehouses, often large volumes built for the handling and storage of goods in transit, are located in the vicinity of docks, canals and railway terminals.¹² These buildings lend themselves easily for transformation and adaptation. Warehouses get in this way a second chance, but also the chance to confirm the intrinsic value of the buildings themselves. They can house different new functions, from offices, theaters, restaurants, shops till dwellings; it is possible to convert them into almost anything. By converting those buildings into new uses, it may teach today's architects something about this established pattern.¹³

Warehouse' structure is eminently adaptable. The external walls are made often off thick stone or brick masonry. Large open internal spaces reveal a cast-iron structure of columns and beams, rough timber posts and beams, or a combination of iron and timber. Most

WAREHOUSES

of the warehouses fit the prescription for new building proposed at the time of the oil crisis in 1973: '*long life, loose fit, low energy*'.¹⁴

The external characteristic of the warehouses is the fenestration. Windows are usually small and repeatedly placed in the facade. The width of the opening is often determined by the span of a brick arch. The window openings can be easily enlarged by inserting steel or concrete lintels, but often it is not advised to do that. The repetition of windows on a long facade gives the building an indeterminate character which makes it possible to add a few bays or even a floor without causing harm.¹⁵ A vertical rhythm on the facade is formed by the crane bays.¹⁶

Internal large open spaces are divided into bays by exposed structure of rough timber posts and beams or cast-iron columns and beams with brick vaulting.¹⁷ The character of the interior is hard to maintain because of the fire regulations. According to these regulations, large spaces have to be subdivided by fireproof walls and the old floors have to be protected with false ceilings. Therefore during the transformation of those buildings, the old floors have been often replaced by reinforced concrete floors, within the existing shell. The character of the public exterior is more important than the private interior and that is the reason why it has to be preserved.¹⁸

ADAPTATION

"The characteristics of the warehouse make these buildings eminently adaptable. Perhaps more than any other building type they fit the prescription for new buildings proposed at the time of the oil crisis in 1973: 'long life, loose fit, low energy'." (Cantacuzino, 1989, p. 89)



Oranje Nassau Veem in Amsterdam (Rijksdienst voor het Cultureel Erfgoed, S.D.)

WAREHOUSES

Warehouses are able to provide a variety of new uses, which include offices, schools, cultural functions as theaters, restaurants, shops and housing.¹⁹ This wide range of transformations makes it almost impossible to talk about a conceptual nature of converting warehouses.²⁰

History shows that large warehouse complexes or 'Vemen', which are built in the nineteenth century, are often repurposed as office buildings for creative professions by artists and squatters. The earliest example is The **Oranje Nassau Veem** at the Van Diemen street, in Amsterdam. In the early eighties, this building is squatted not with the intention to live (as usual), but to make a work premises with a wide variety of professions.²¹

Other groups of users of squatters' premises, in the city, take the development of the 'Veem' as an example for their own initiatives. The empty warehouses in the Oostelijk Havengebied of Amsterdam are, from the 80s, used by artists, squatters and urban nomads. Unlike the (entrepot)warehouses, the premises are used as live-work-buildings especially for creative professions from the beginning.²² This was possible because the strip of warehouses of hundreds of meters length has floor plans which are free to arrange and have high load capacity per square meter.²³ The term 'breeding ground' or 'creative industries' did not yet exist, but 'Pakhuis Wilhelmina', 'Vrieshuis Amerika' and '**Pakhuis de Zwijger**' can be seen as the forerunners of the current breeding places or business centers for the creative industries. New users proved the value of large modern warehouses.²⁴

Derived from this, the '**Graansilo's**' in Amsterdam also have a mixed work and living program. The social control, which derives from

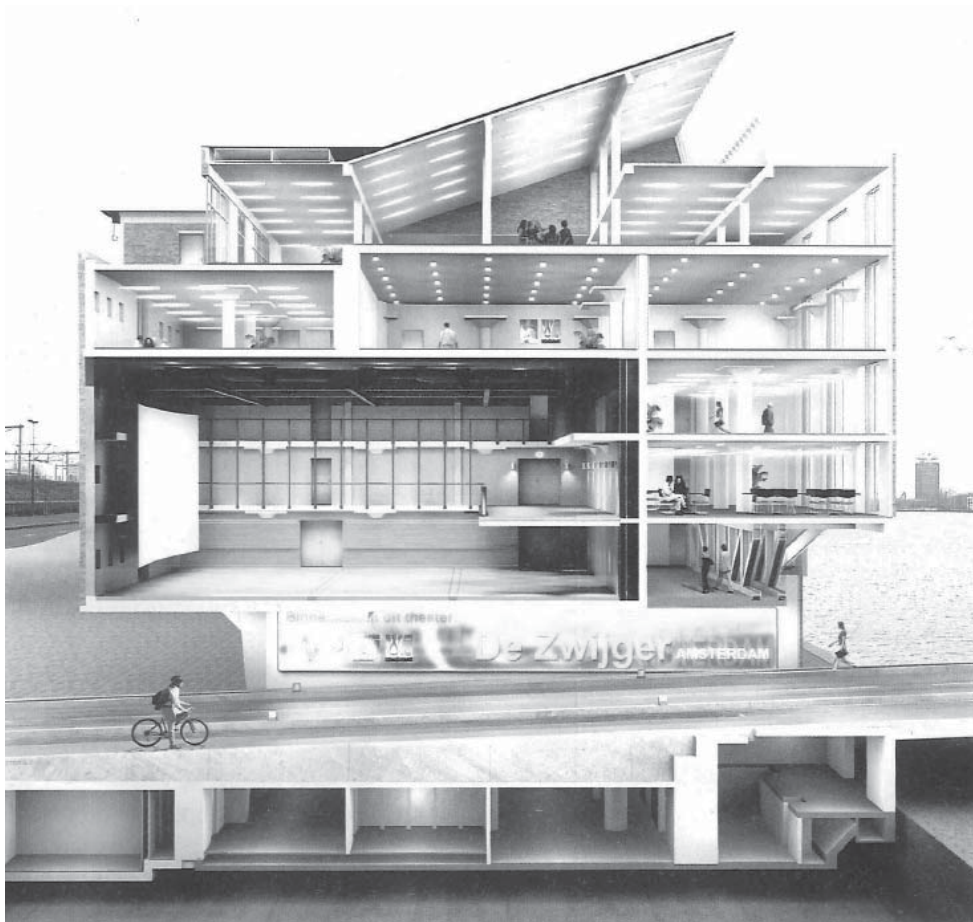

Pakhuis de Zwijger in Amsterdam (Kalk, 2010, p. 58)

WAREHOUSES

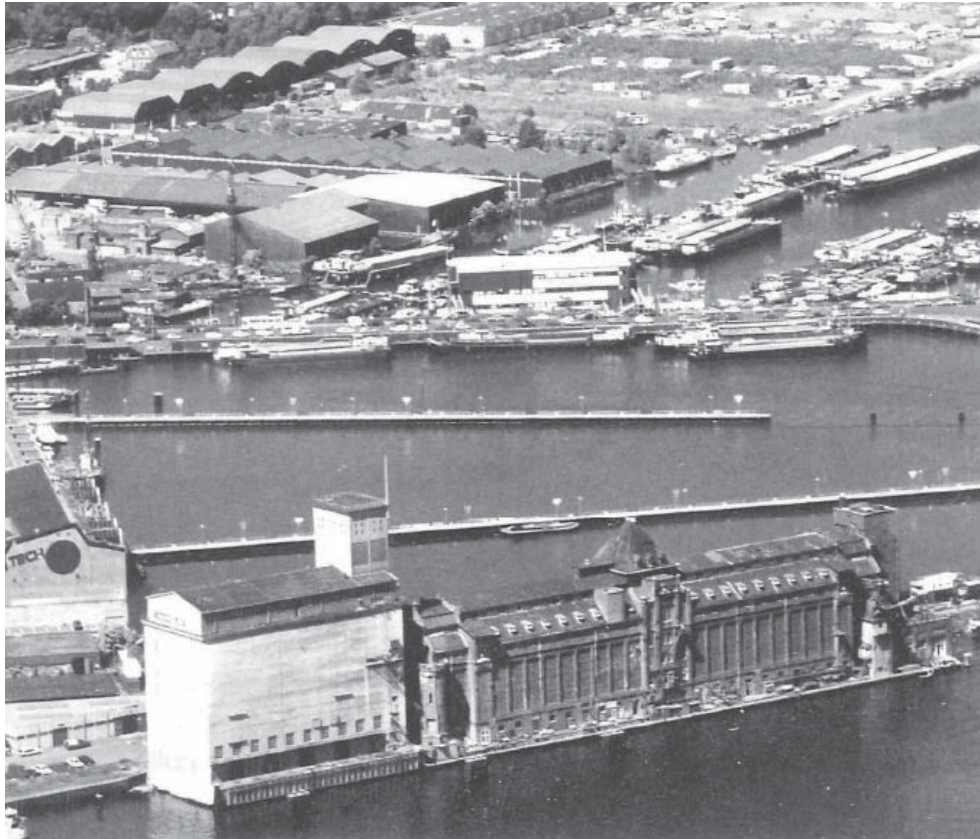

Graansilo's in Amsterdam (Kalk, 2010, p. 54), (Kalk, 2010, p. 59)

such a mixture, also enlarges the safety on the street, whereby a nice and lively neighbourhood with day and night time activity will arise around these buildings. This is part of the success of transforming warehouses.²⁵

However, most warehouses are transformed into (luxury) housing.²⁶ This started in the nineties, when a trend of 'loft-living' arose. Living in former warehouses became popular among young, highly-educated households, without any children.²⁷ These creative persons and, in slightly wider context; knowledge workers, prefer a working and living environment with lots of personal identity over a uniform business park on the edge of the highway or a Vinex-house. The raw and unfinished character of factory buildings and sites addresses this group and their customers.²⁸

Industrial complexes and old neighbourhoods offer a variety of atmospheres and functions. Optimal accessibility and parking determine no longer the choice for a business location. A unique atmosphere, perception of architectural space and proximity to an inner urban environment became the decisive location factors for the creative sector. Their location within the city center enabled most warehouses to be re-used as residential building, and thereby remained save from demolition. For that reason there are not many vacant warehouses.²⁹

Fire regulations make it difficult to maintain the character of the interior. "*They demand the subdivision of large spaces with fireproof walls and the protection of the floor structure with false ceilings.*"³⁰ To meet the demands for subdivisions the best solution seems to be the conversion into small units; as offices and apartments. This solution demolishes the open internal character of the building the most. Although in most examples, as the 'Entrepotgebouw' and

WAREHOUSES



Jobsveem in Rotterdam (Steenhuis & Meurs, 2011, pp. 32-33)

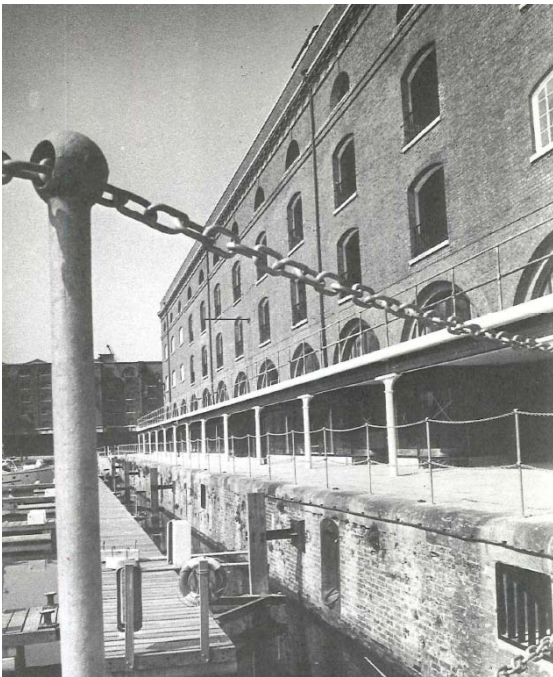

I-Warehouse in London (Cantacuzino, 1975, p. 241)

'Jobsveem' in Rotterdam, this internal character is still visible in rooms itself. This internal character contains the appearance of one or more cast-iron columns in a room. The user remembers by this appearance of columns, the history of the building and at the same time these columns insinuate a division of the space. Dwellers are thereby able to divide their apartments freely. This makes the dwelling ideal for their target group: creative people.³¹

A radical solution to meet the requirements for the fire regulations is to exchange the wooden floors and beams for concrete floors and beams. This at least preserves the character of the existing shell.³²

Even more extreme; 'Jobsveem' had a roof in extreme bad condition, which was therefore replaced by a new storey with ten penthouses. The first floor of the building was completely removed, to provide a height of 6 meters for commercial spaces on the ground floor.³³

In the 'Entrepotgebouw' the floors and beams were replaced for concrete slabs. This was not done to meet the fire regulations, but done because longhorn beetles were eating away the wooden structure.³⁴

Even after the replacement of floors, the storeys of warehouses are relative low, because the storage of products was done by hand.³⁵ This resulted in a constant repetition of the level of floor to ceiling. This monotony can be broken down by trimming the floor structure and forming wells; as an example this can result in the dwelling typology of lofts.³⁶

Warehouse windows tend to be too small for residential needs. Therefore some windows of the 'I-Warehouse', at the St. Katharine Docks in London, had to be enlarged. This was done downwards to

WAREHOUSES

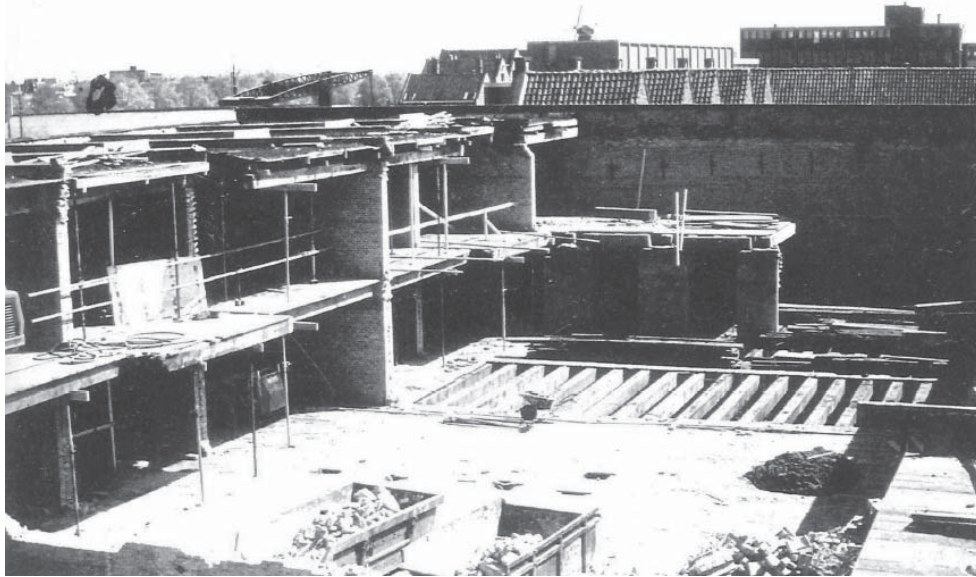

De Houtman in Amsterdam (Kalk, 2010, p. 55)



Maandag tot en met Zondag in Amsterdam (Kalk, 2010, p. 56)

form openings for recessed balconies.³⁷

Since storage of products does not need to have daylight penetration, old warehouses are much deeper than meant to be residential buildings. Some warehouses are up to 45 meters deep. This depth can be enlarged " *by inserting steel or concrete lintels, is as easy as it is ill advised*" .³⁸

Warehouses can be re-used as residential buildings, when light courts are added; to provide more daylight penetration. The addition of daylight in deeper warehouses results in courtyards within the building.

Warehouse '**De Houtman**' in Amsterdam is one of the first warehouses which is renovated during the city renewing. This building is made suitable for social housing by adding a courtyard within the building. The building consists of 51 dwellings and 37 HAT-units (subsidised dwelling-units for one- and two-person households).³⁹

In smaller warehouses this addition of daylight results in atria. Deep storeys will thereby be divided into two or more apartments.⁴⁰ When the storeys are less deep the atria will not be in the length of the building but in the depth. The division into two or more apartments is than established by a corridor.

Examples are the 30 meters deep warehouses '**Maandag tot en met Zondag**' in Amsterdam. Here are transparent central spaces established by creating atria, with shed roofs, in length of the buildings. These are also used for accessing the dwellings.⁴¹

Another example is '**Jobsveem**', which is 25 meters deep. Three big openings in the facade were made to situate big atria in the building, which were used to give access to the dwellings and to

WAREHOUSES



provide daylight penetration in the dwellings. The glass roofs of the atria can be opened when the weather allows it or when there is a fire in the building.⁴²

Another way to add daylight penetration is to shorten the building.⁴³ Hereby the rear part of the warehouse will be demolished and replaced by a new back facade.

Another way of changing the size of the building is to enlarge the building volume. The repetitions on the long facade make it possible to add a few bays or a floor without causing harm. This can be done in the same style or by expressing a contrast.⁴⁴

"The most successful conversions have been of warehouses where, in also providing facilities for shops, it has been possible to maintain and even improve the open character of the space." (Cantacuzino, 1989, p. 190) The '**Entrepotgebouw**' is named a few times before, and is also a great example of a residential building in combination with offices and facilities for shops; thus maintaining or even improve the open character of the space, it will be the main case study for this chapter.



Entrepotgebouw in Rotterdam (own illustrations)

WAREHOUSES

HET ENTREPOTGEBOUW



WAREHOUSES

HET ENTREPOTGEBOUW

Name: het Entrepotgebouw

De vijf Werelden

Location: Rotterdam

Original function: warehouse

New function: dwellings, supermarket,
shops, restaurants, offices

Architects: Barend Hendrik Beijderwellen
(original design), Cepezed (re-use)

Area: more than 30,000 sqm

Year: 1879 (original design), 1991 (re-use)

HET ENTREPOTGEBOUW

HISTORY

The 'Entrepotgebouw' was erected in 1879. It was a legal construct that served to facilitate international trade. It stored goods which came from abroad but whose destination was still undetermined.⁴⁵ Until 1990 it functioned as such. Since 1991 project developer Mabon had plans to develop an Exotic Festival market with offices and dwellings within the building, but this market never came into being. Cepezed however made the design, which contained stores, a supermarket, offices and dwellings.⁴⁶

BUILDING ENVELOPE

The 'Entrepotgebouw' is a rectangular building measuring 200 metres by 36 metres. With a basement and four floors, it had a total size of more than 30,000 sqm. During the transformation of the 'Entrepotgebouw' into a residential building, an extra storey was added resulting in a building of five storeys high.

COMPOSITION

The composition of the building consists of 3 big segments (basic compartments) in the middle of the building and 2 smaller ones (side compartments) each at one side of the building. Within the 5 segments of the building, the redevelopment has completed 2 kinds of lofts and 3 kinds of maisonettes, which are some 13 meters deep. On the ground floor are cafes and restaurants at the harbour side; on the other side are the shops and a supermarket located. The depth of the building was too big for residential use. That is the reason why the atrium is added in the middle of the building during the transformation of the building. This atrium, which cuts the building into two parts along its entire length, provides daylight in the public functions in the base, in the offices and in the dwellings.



HET ENTREPOTGEBOUW | ROTTERDAM, NETHERLANDS | 1997

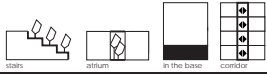

WAREHOUSES

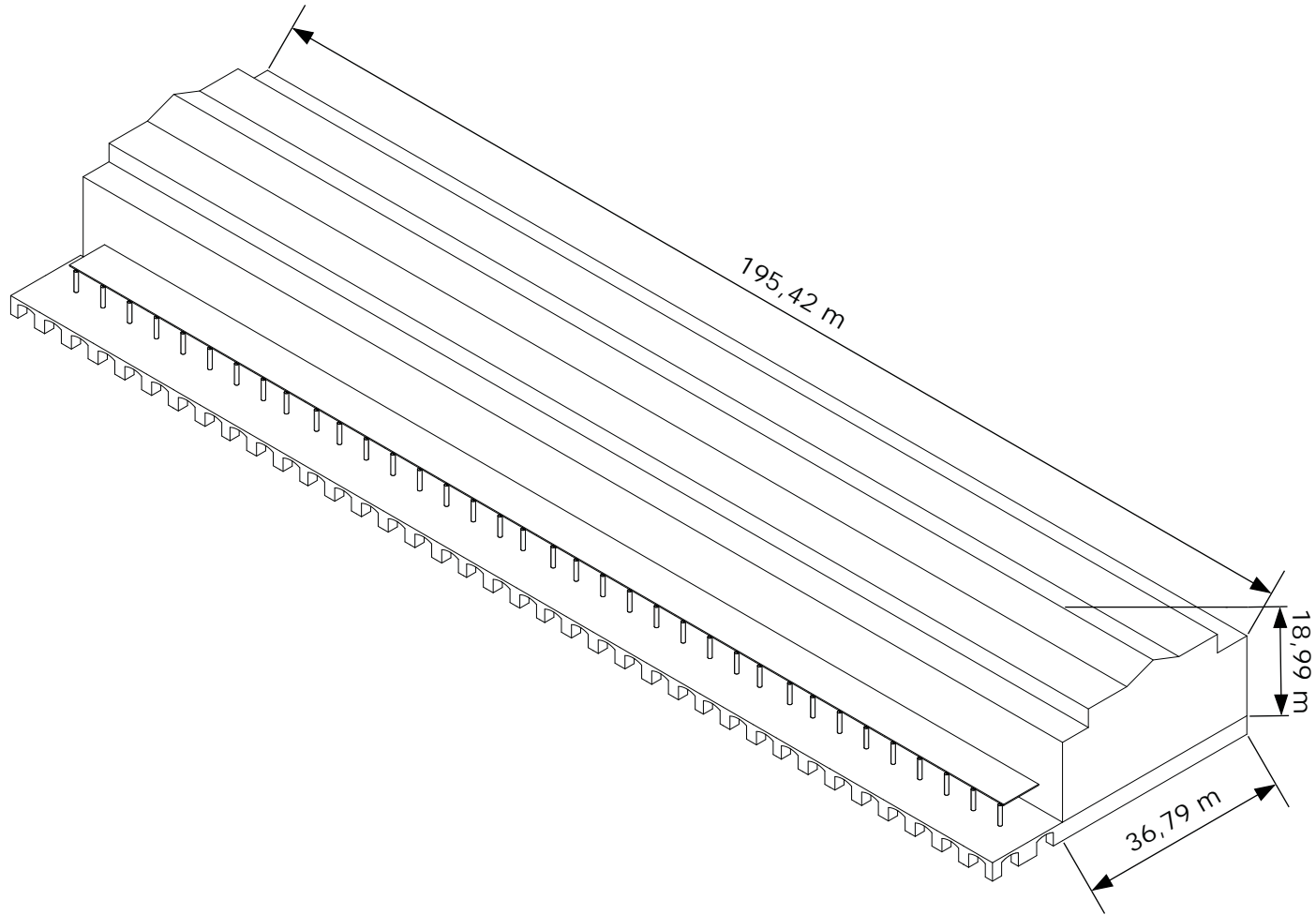

Building envelope scale 1:1000 (own illustration)

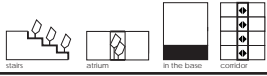

WAREHOUSES

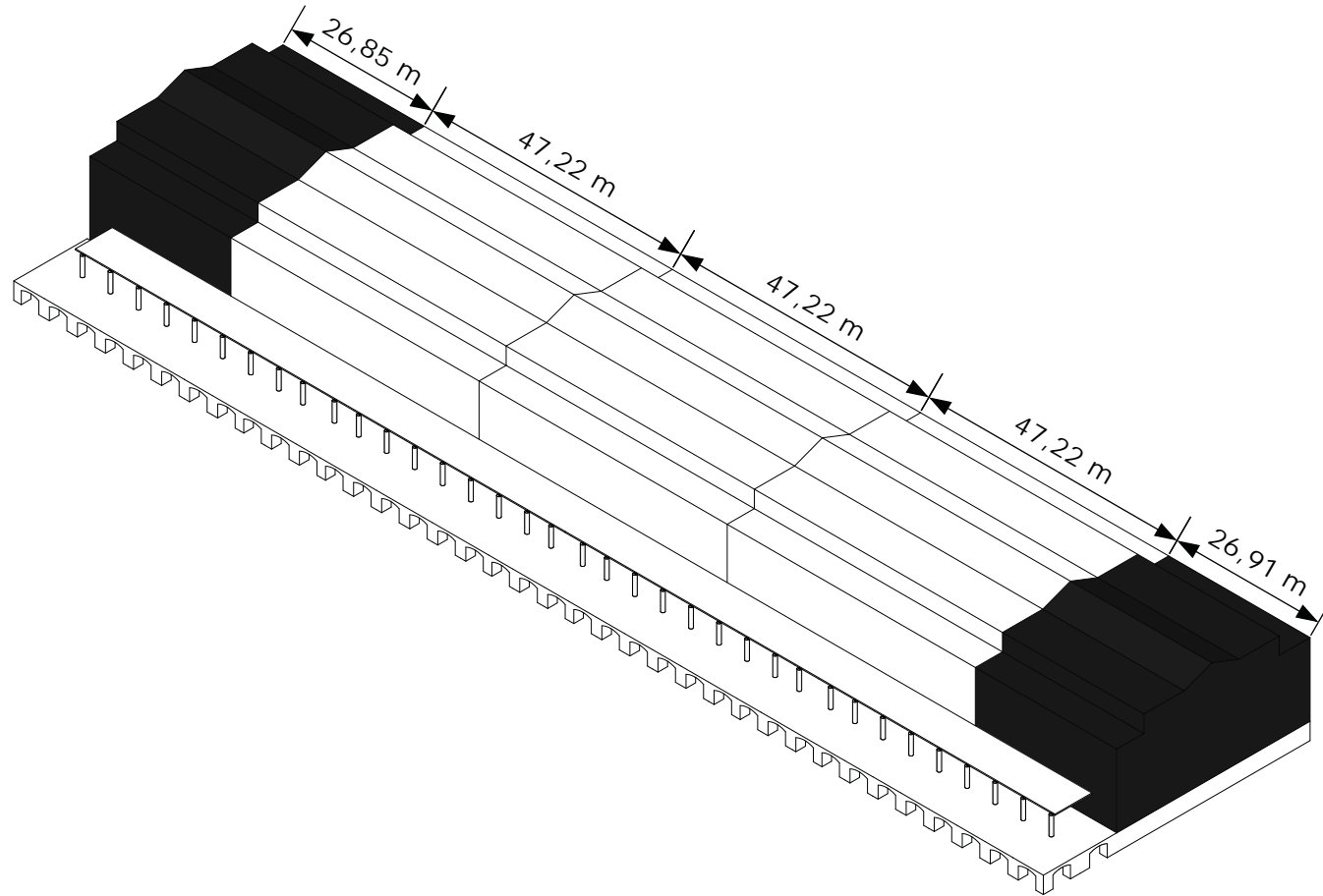

Composition scale 1:1000 (own illustration)

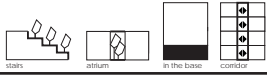

WAREHOUSES

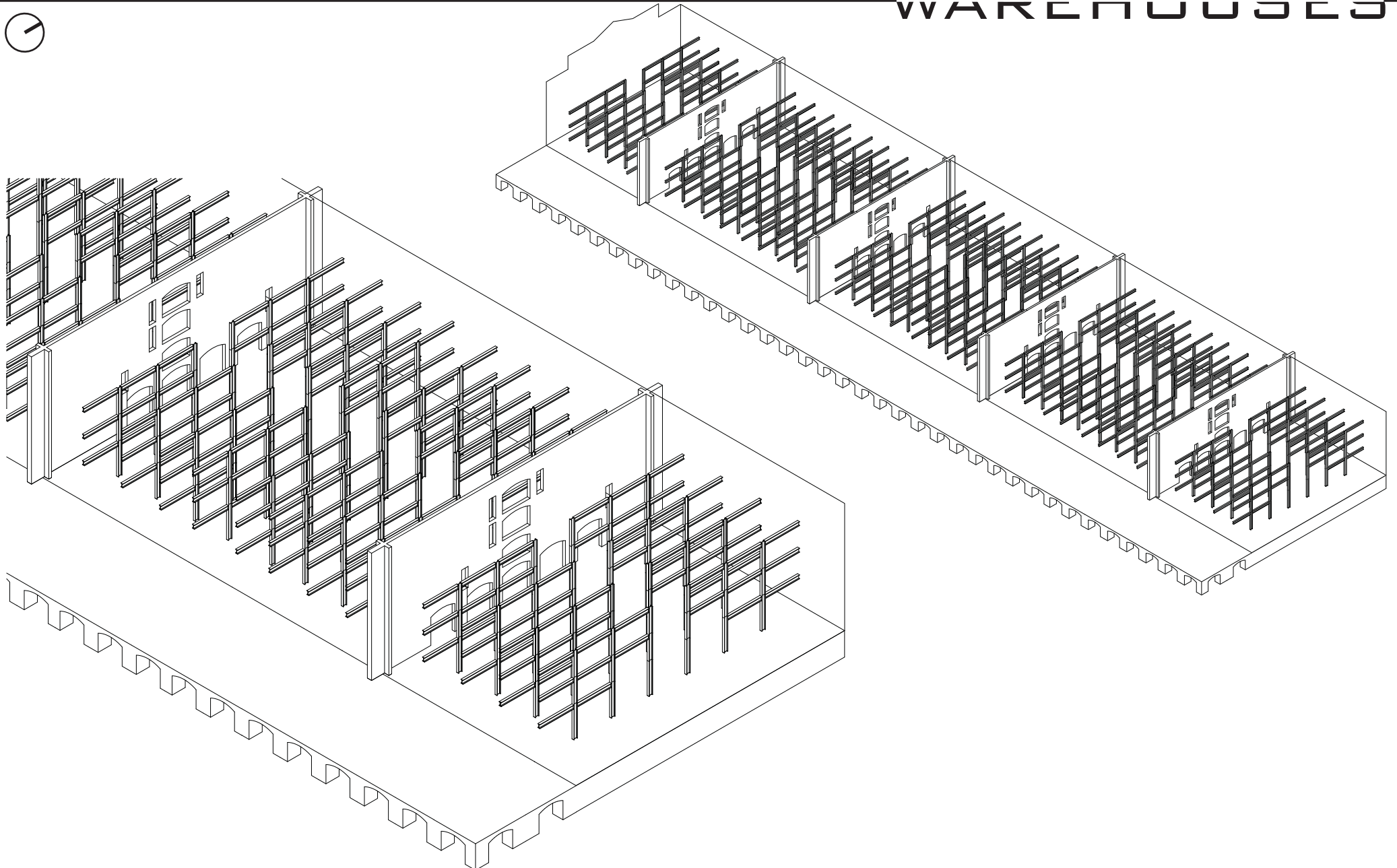

Structure scale 1:500, 1:1000 (own illustration)

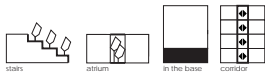

WAREHOUSES



First floor

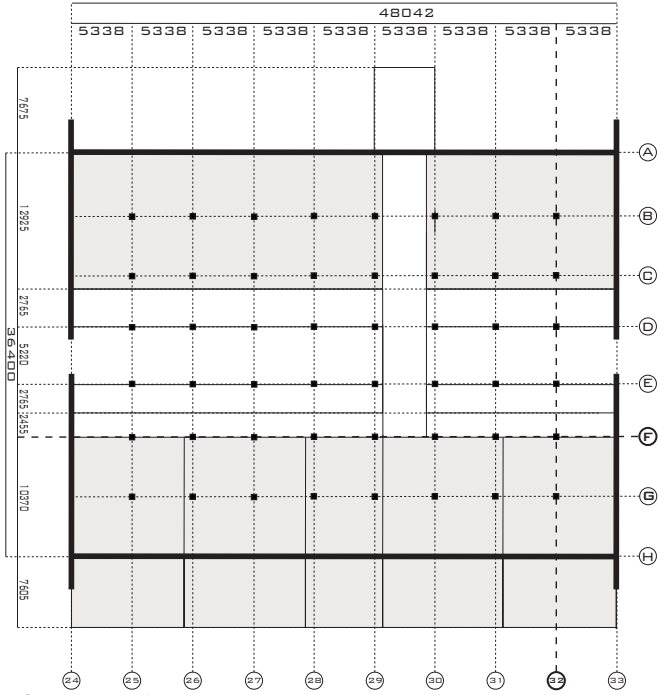

Cross section

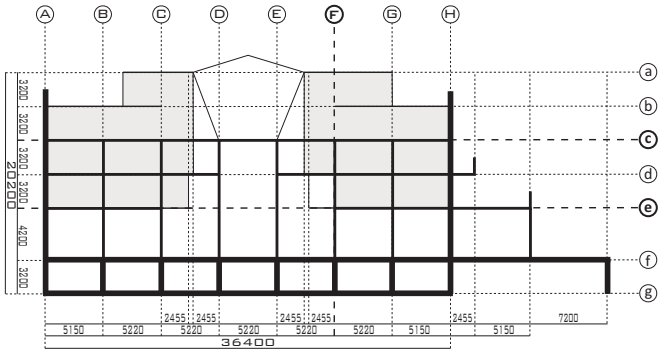

Grid structure (own illustration)

Third floor

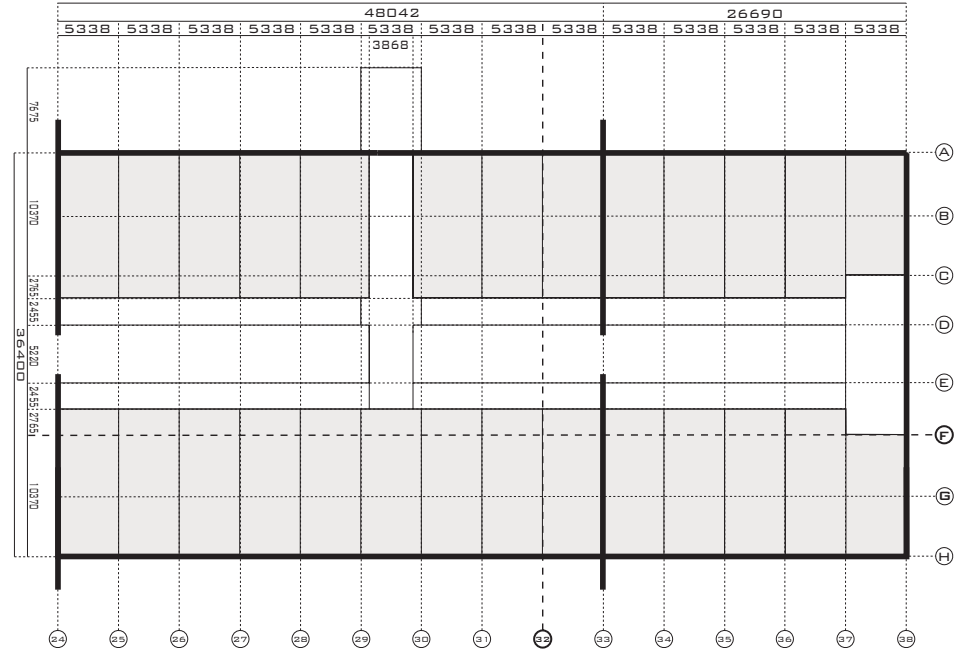

Longitudinal section

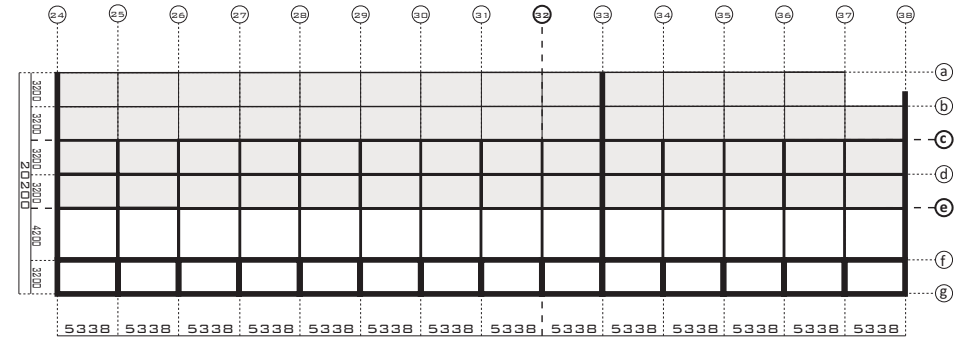

CONTENT - structure

- most important (foundation & base-ment)
- less important (steel beams & columns)
- functions
- least important (new floors & walls)
- circulation

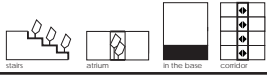

WAREHOUSES

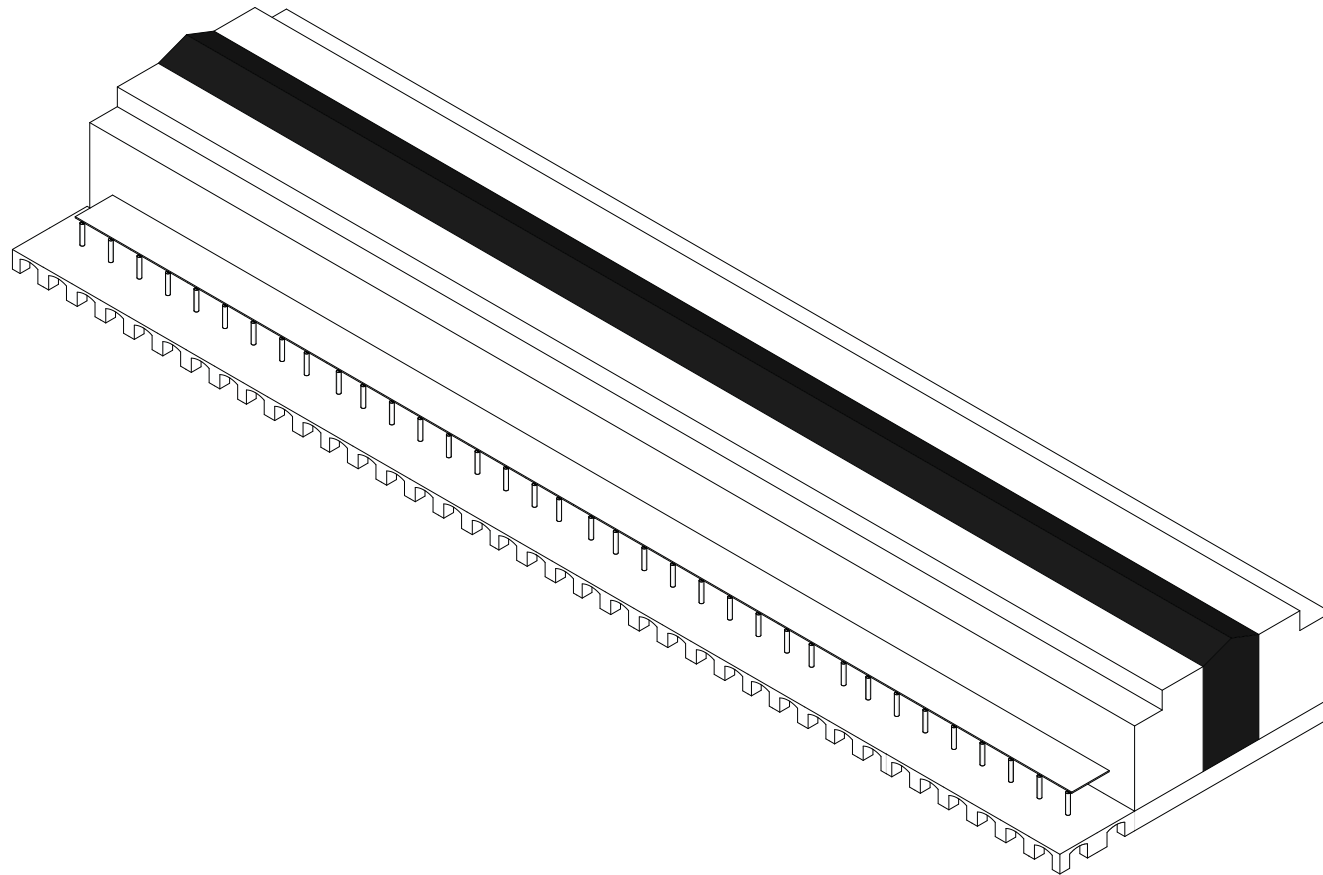

Atrium scale 1:1000 (own illustration)

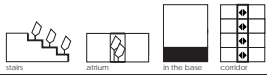

WAREHOUSES

STRUCTURE

The plan of the building is based on a grid of 37 times 5.338 metre in length by 5 times 5.22 metre plus two times 5.15 metre on the sides in depth. This results in a building of 3 compartments of 48.042 metre by 36.4 metre (basic compartment) and 2 compartments of 26.69 metre by 36.4 metre (side compartment), which results in a precise length of 197.506 metres (Bakker, 1996, pp. 26-31).

The drawings on the left show one basic compartment and one side compartment of the building on the third floor (Fig. 16b), next to one basic compartment on the first floor (Fig. 16a). The drawings show that most dwellings are in depth strictly situated within the grid. However, dwellings consisting out of more than two banches, on the second and third floor (fitting within the grid) have measurements different from the grid due to the galleries for circulation. The height of every storey is 3 meters plus 0.2 meters of the floor height, whereas the ground floor has a height of 4 meters.

The cast-iron structure, which consists of columns and beams, is placed in the width direction to stabilize the building. Four thick fire walls divide the building into 5 parts. These 45 centimetres thick walls give stability in the longitudinal direction of the building. The masonry facades are also part of the structure of the building.

PROGRAM

Retail is located in the base and 107 dwellings are situated above. The lower you are in the building or the more to the centre of the building, the more collective the spaces become. There is a basement with storage for residents and retail, which is meant for collective use. The public domain is situated in the base and centre of the building, where shops, restaurants and a supermarket are placed around an atrium. Next to the retail function in the base, the building has an office function on the first floor on the north side. The offices are part of the collective realm, because they are situated along a collective corridor. The circulation system, which gives access to the private dwellings for multiple dwellers, is also part of the collective realm. Spacious maisonette apartments are situated on the three floors above the offices. The lofts are situated on the first and second floor along the south side of the building and above the maisonettes. The private realm of the dwellings is placed on the outside of the building.

FACADE + MATERIALS

The facade of the building is made of brick masonry with a depth of 80 centimetres. The warehouse building is characterized by the large openings in the facade on the ground floor and on the basement level. Additionally large cranes triumphed on the long south side of the building to reload the goods from the ship into the warehouse.

The materials which are used in this building are brick, steel and concrete. The facades are made of masonry brick. The steel structure of beams and columns is combined with concrete wing floors.

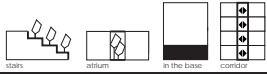

WAREHOUSES

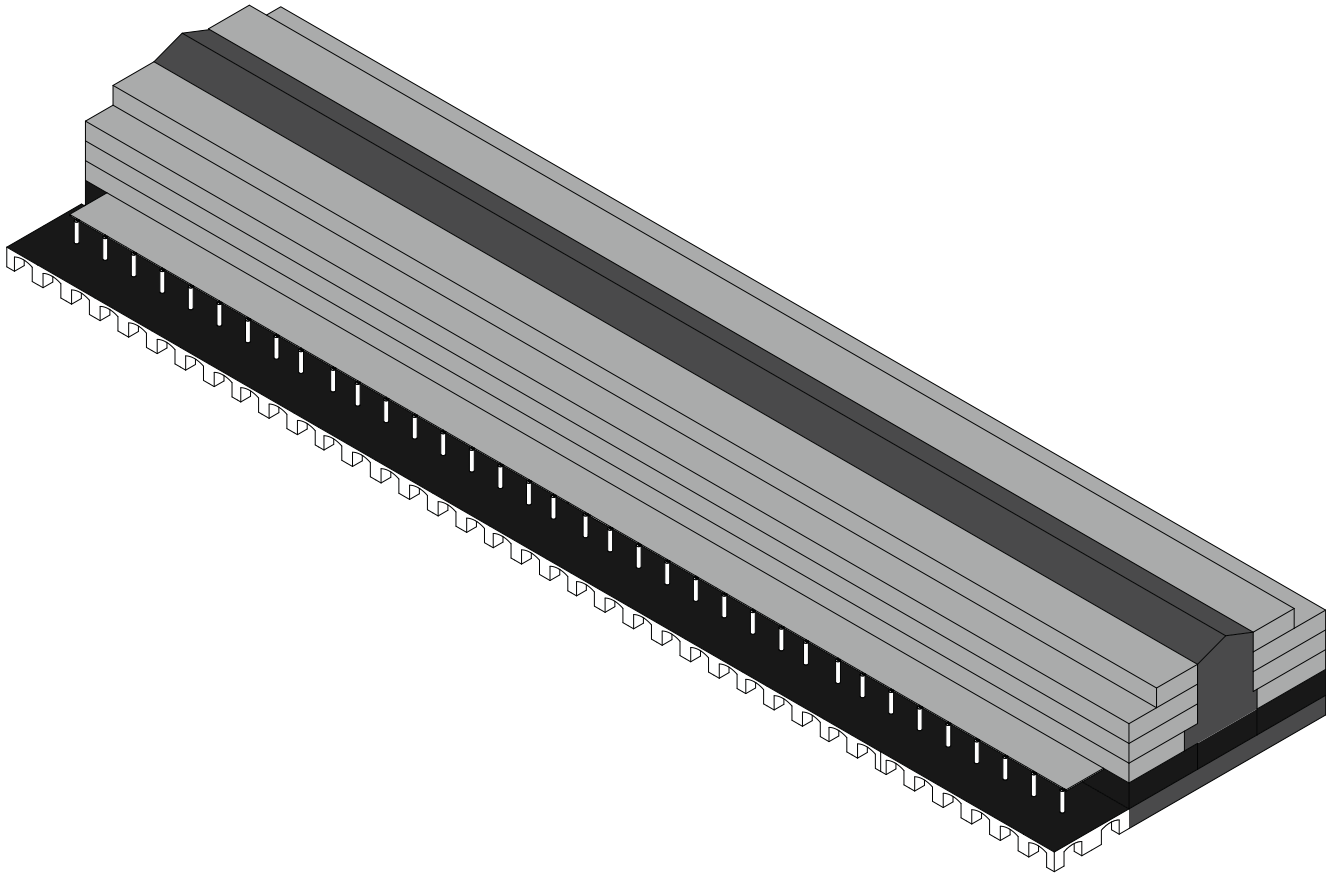

Public, collective, private scale 1:1000 (own illustration)

CONTENT

public

collective

private

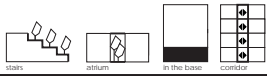

WAREHOUSES

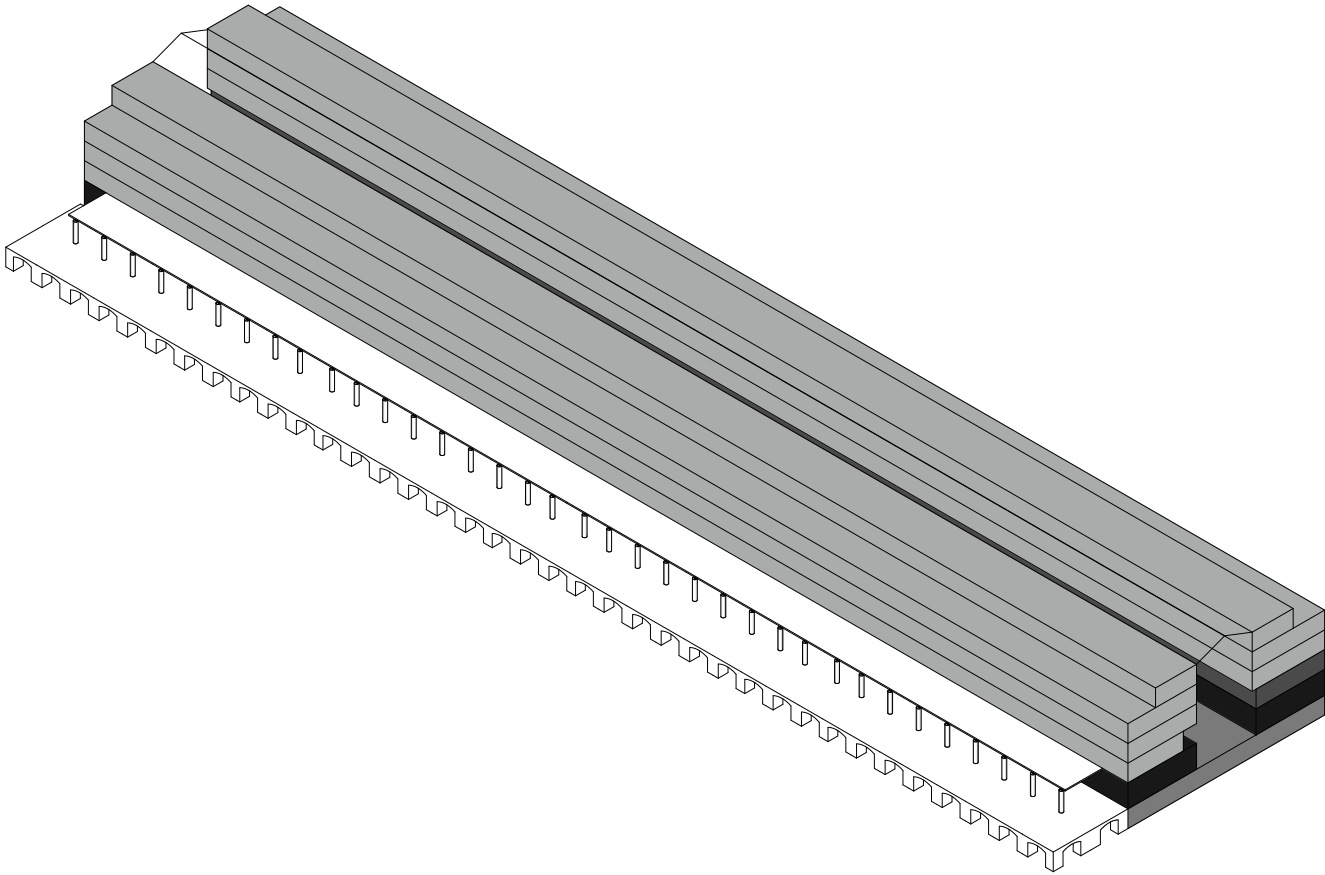

Program scale 1:1000 (own illustration)

DWELLING WITHIN THE NEW HISTORY | WAREHOUSES

CONTENT

- retail
- offices

- storage
- dwelling

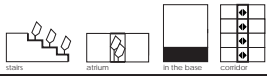

WAREHOUSES

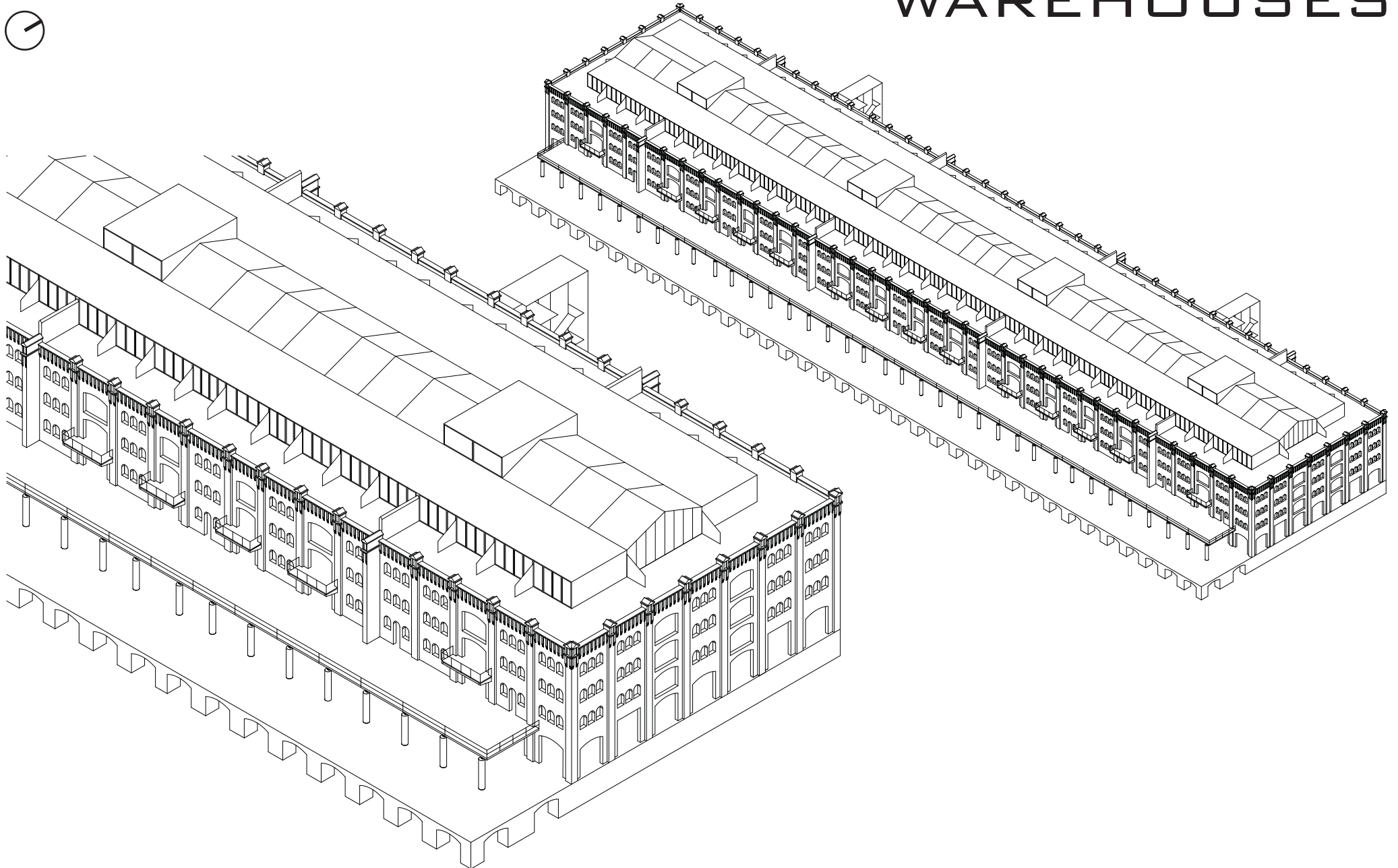

Facade scale 1:1500, 1:1000 (own illustration)

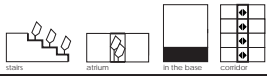

WAREHOUSES

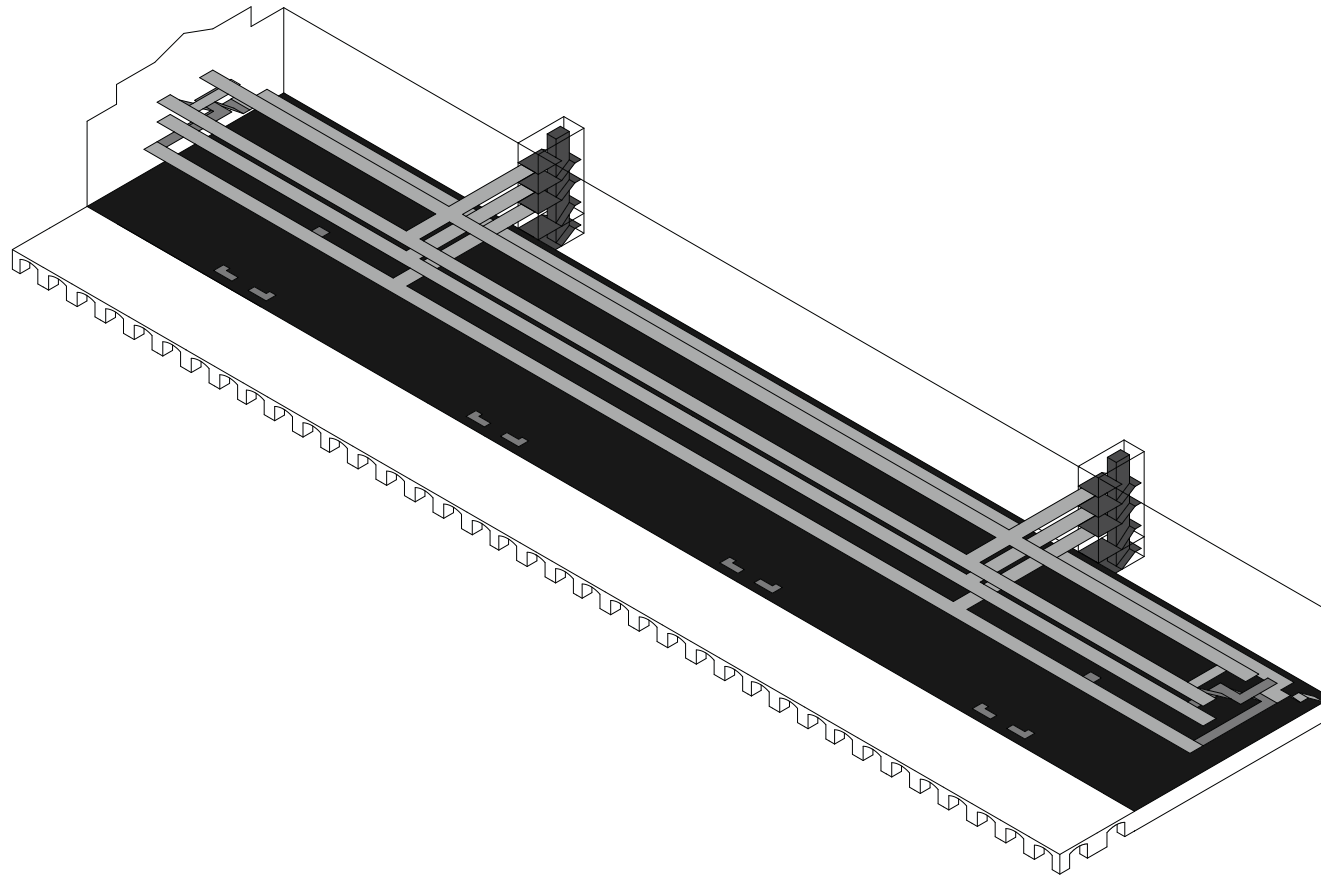

Circulation scale 1:1000 (own illustration)

CONTENT

- public space
- circulation core
- emergency stairs
- corridors

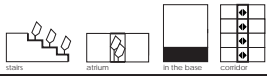

CIRCULATION

The circulation within the building is to type as a corridor even though the corridor consists of two galleries along an atrium. The atrium provides natural daylight for the corridor and public functions in the building, which makes the building more spacious. With the atrium in the belly of the building and the galleries along it, there is a visual relation between the public and collective domain. This visual relation is not of any influence on the public domain of the dweller, but does enliven the building for both the dweller and the visitor.

The building has several entrances, which are distinguished in three main groups, namely public, offices and residents entrances. The public entrances are located on the east and west side of the building and they belong to the corridor typology. Additionally, there are five entrances spread over the north and south side of the building. In contrast to the normal corridor typology, which is described as a dark space, this corridor is illuminated through the atrium. The basement is accessible through stairs on the south side of the building. The offices have three accesses on the north side of the building and they also belong to the type of corridor. The residents can enter the building in several ways through the public corridor and through the newly added stairwells with elevator on the north side of the building. The dwellings are accessible via a corridor, which is also illuminated by the atrium.

The south side of the building, where most dwellings are situated, consists of three galleries on top of each other. The bottom gallery on the first floor is put a little to the back to enlarge the feeling of spaciousness in the belly of the building. The old steel structure of the building is used to define the separation between dwelling and corridor or gallery and atrium. The gallery and atrium are also separated by glass. The steel structure also pretends to define the separation between dwellings. This is not really the case, because the structural grid and the grid which defines the dwellings are shifted with 30 centimetres. On the third floor there is no original steel structure left. A sloped glass wall is placed on the edge of the gallery to separate it from the atrium. This wall is tilted to the back, which enlarges the penetration of sunlight from the skylight, but reduces the relation with the belly of the building. In this way these upper dwellings are the most private ones.

The north side of the building has only one gallery. This one is connected with the one on the other side of the building with a bridge halfway each compartment of the building. This bridge is also separated by glass from the atrium. When the adjacent maisonettes are three storeys high, dwellers enter on the mid-level of the building, which gives access to an upper and bottom part.

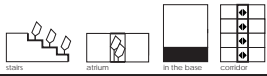

WAREHOUSES



First floor

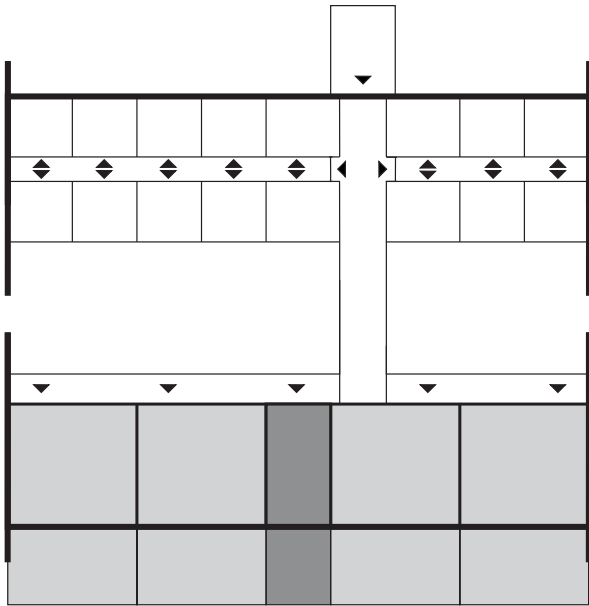

Third floor

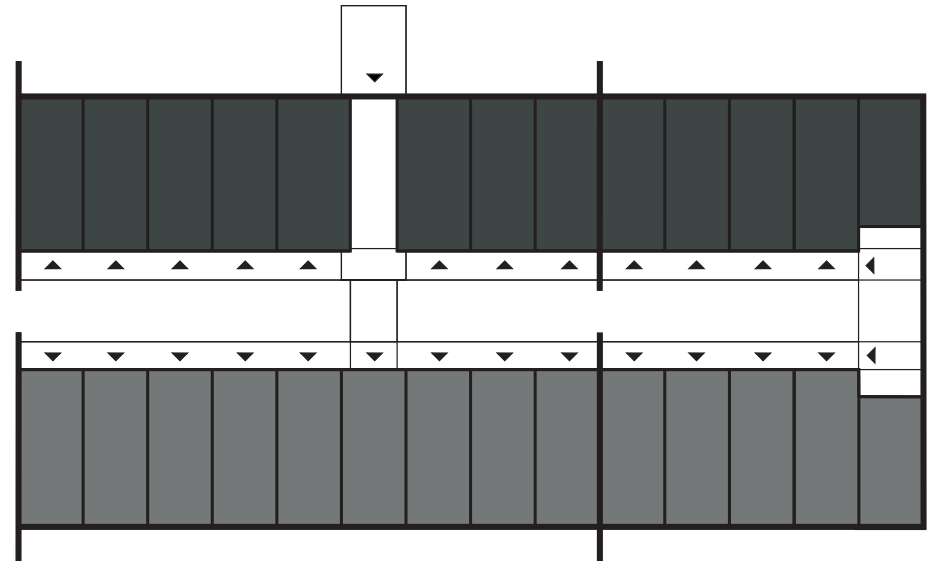

Cross section

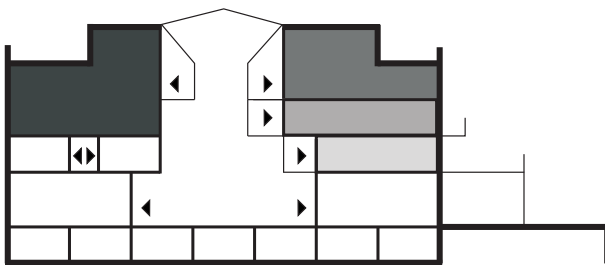

Longitudinal section

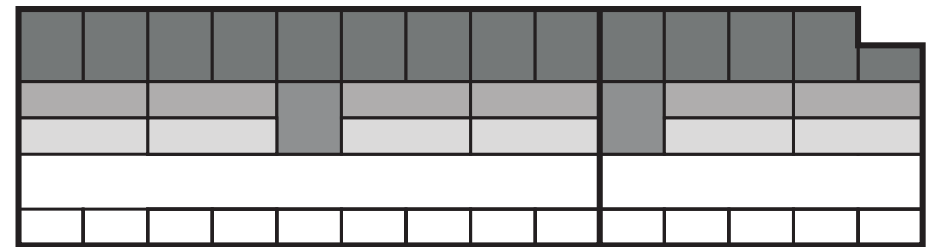

Dwelling typologies (own illustration)

CONTENT

- loft type 1
- loft type 2

- maisonette type 1
- maisonette type 2

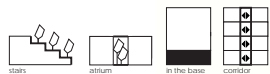

WAREHOUSES

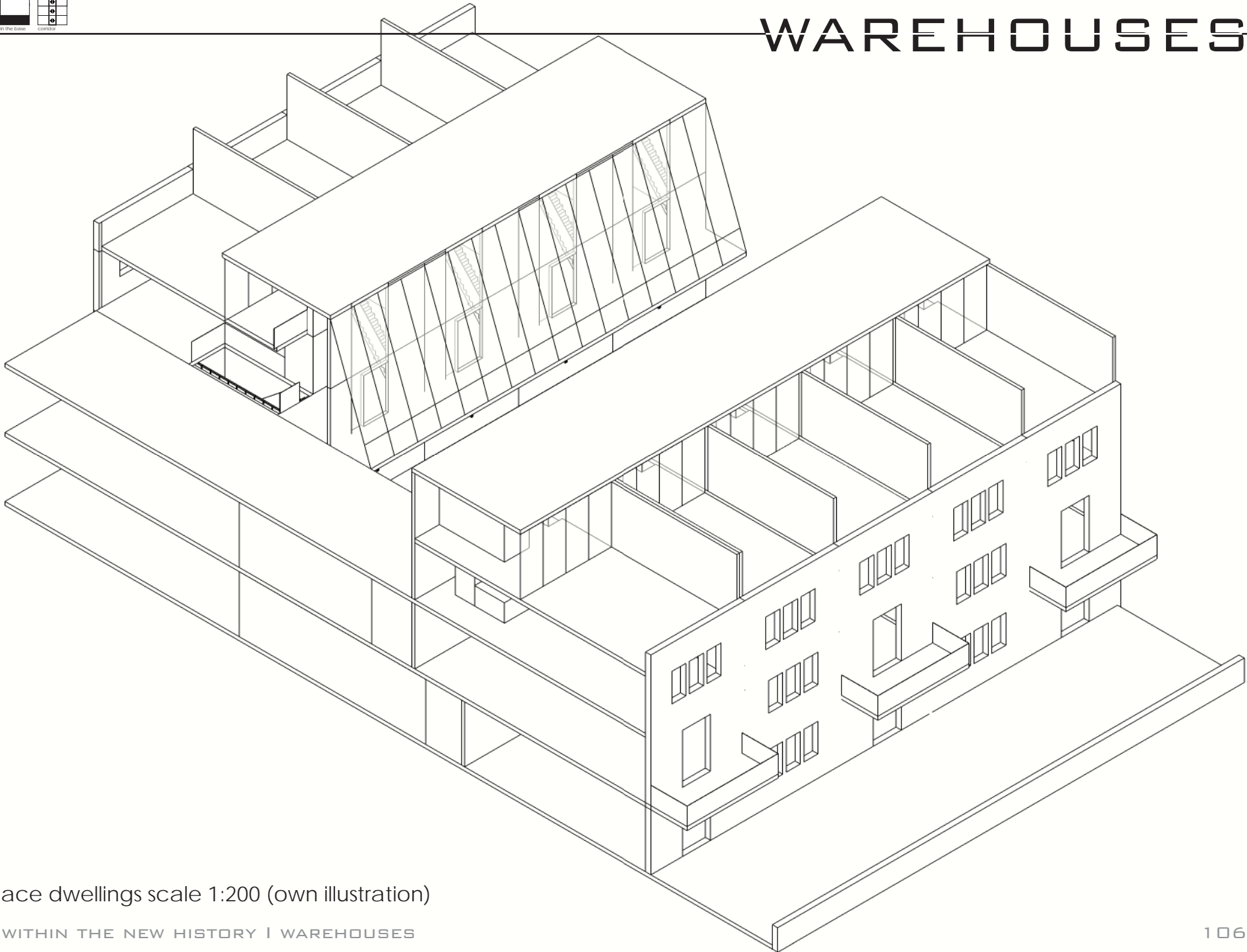

Outside space dwellings scale 1:200 (own illustration)

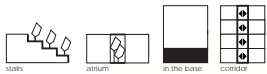

WAREHOUSES

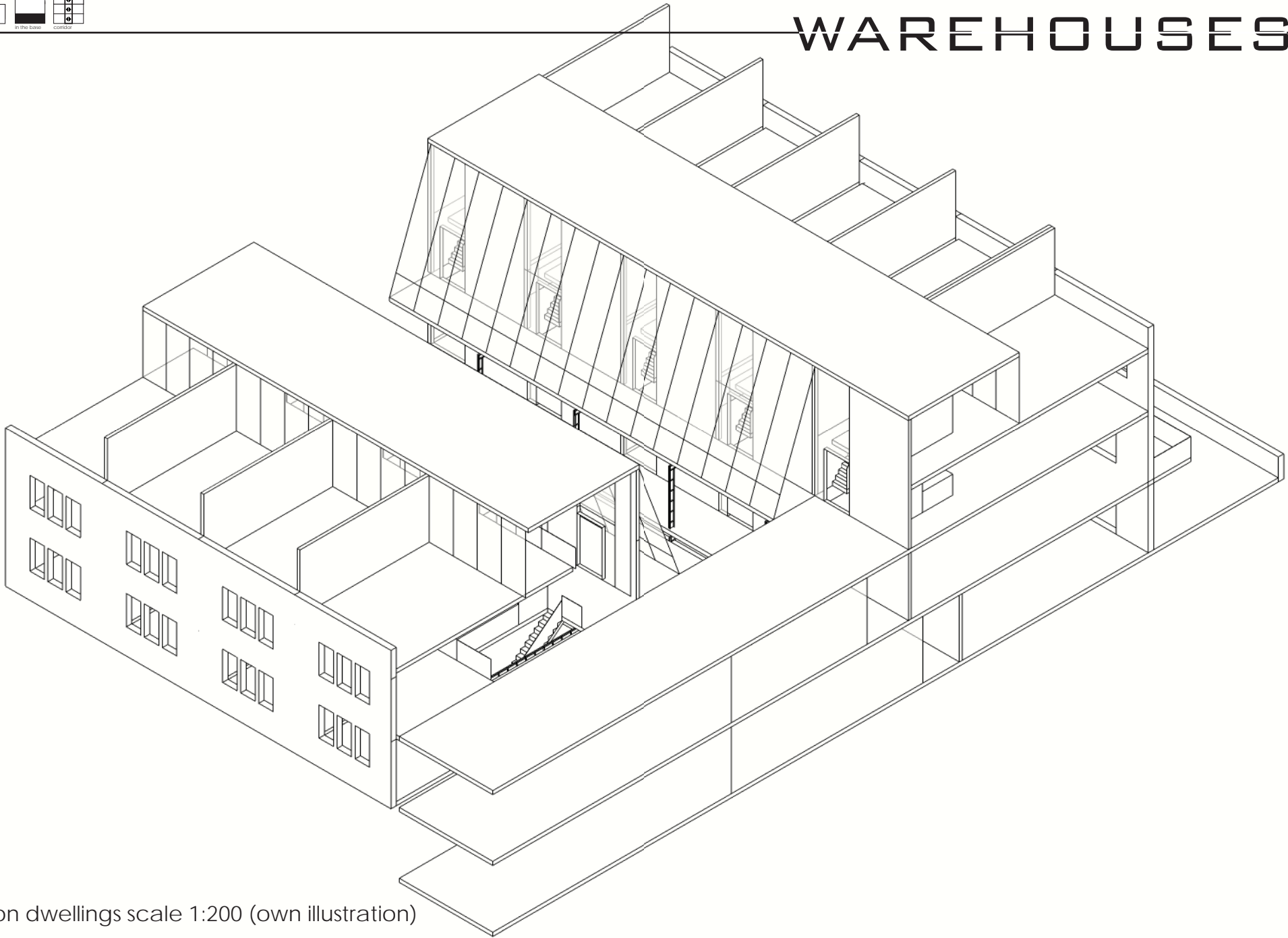

Circulation dwellings scale 1:200 (own illustration)

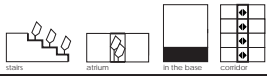

WAREHOUSES

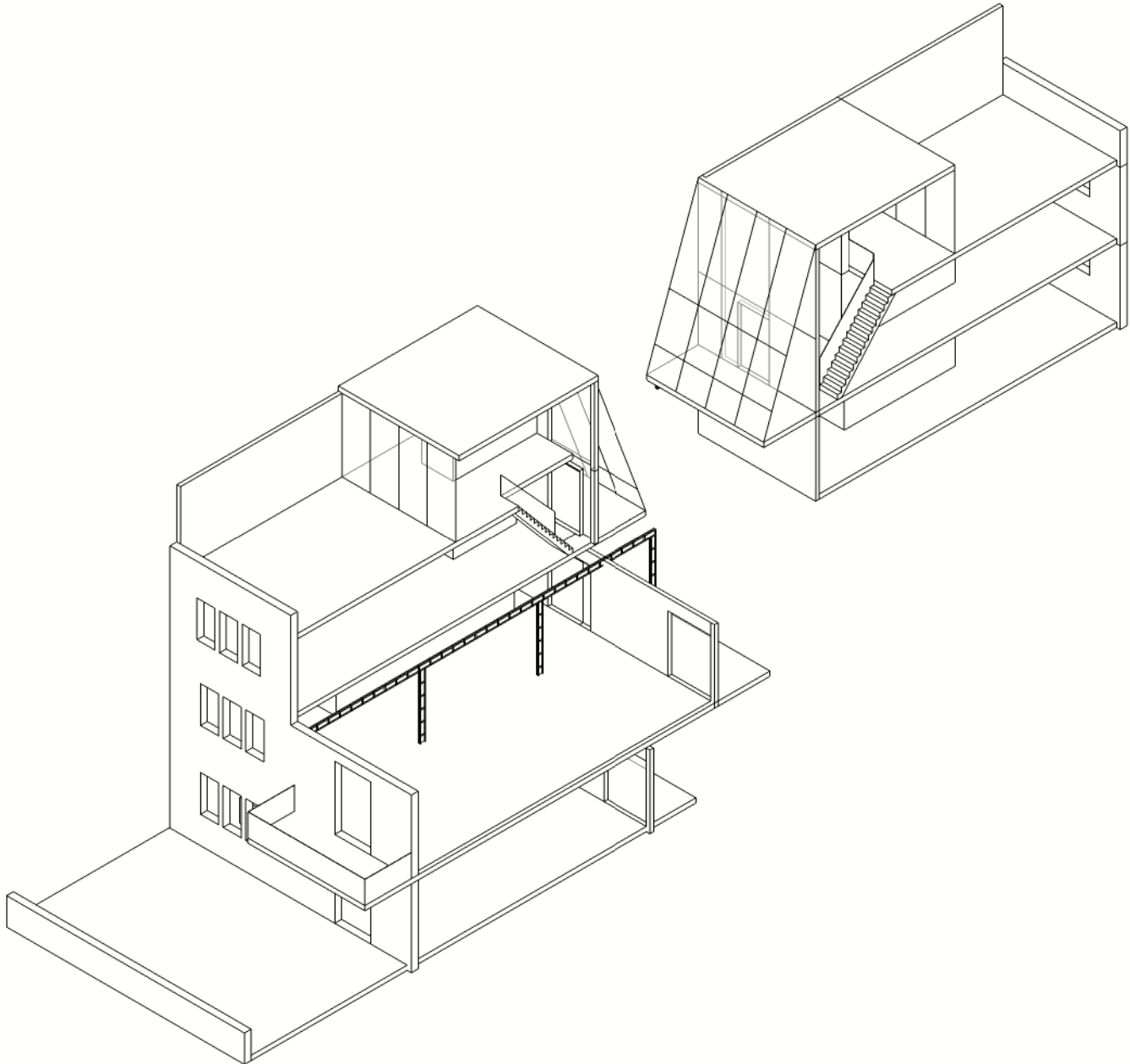

Stacked dwellings scale 1:200 (own illustration)

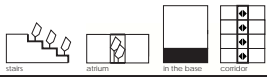

WAREHOUSES

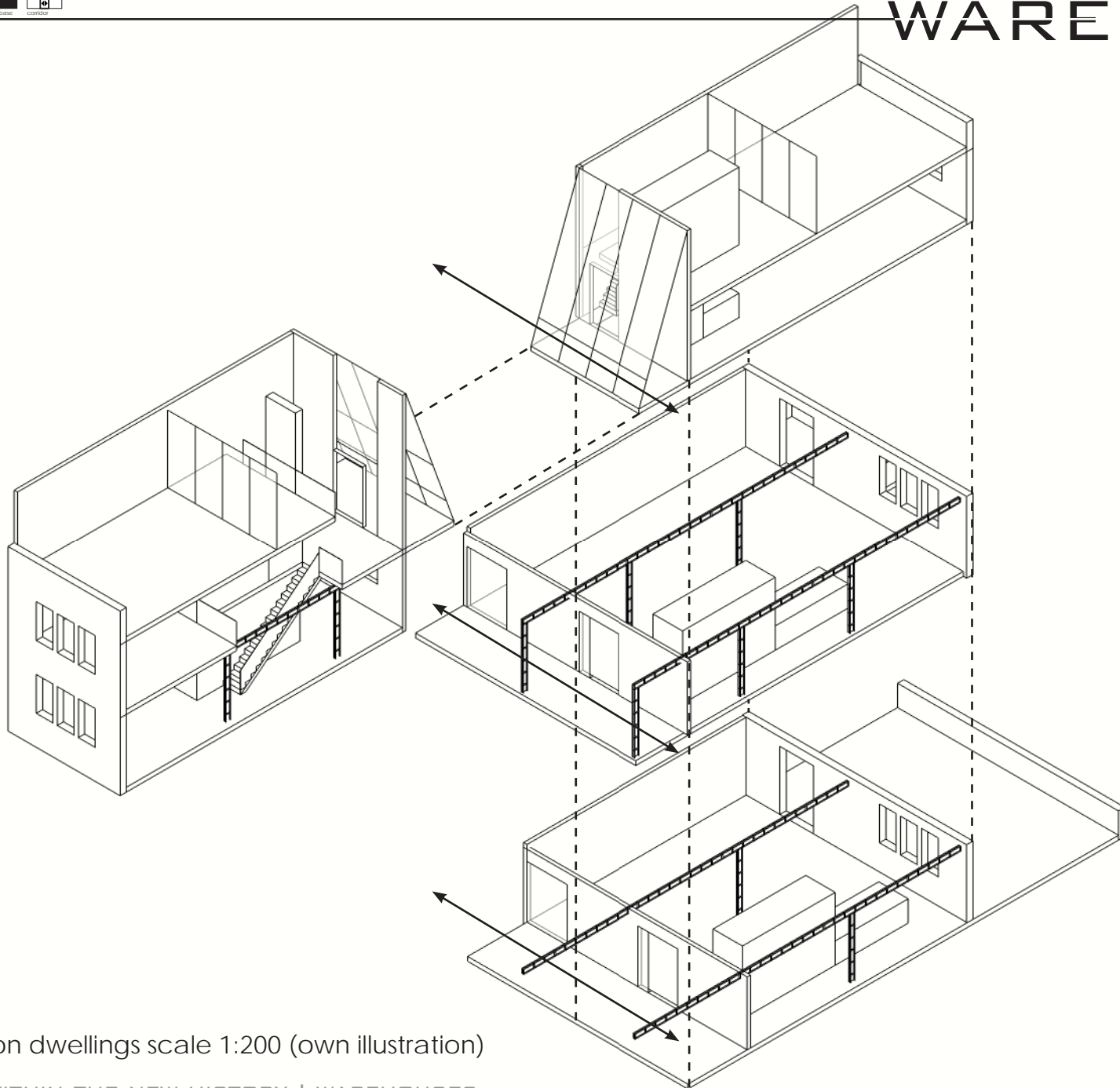

Configuration dwellings scale 1:200 (own illustration)

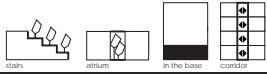

DWELLING TYPES

Two different types of lofts and three different types of maisonnettes are realized within the 'Entrepotgebouw'. The different dwelling typologies will be described here.

LOFT TYPE 1

The first loft type is one big open space with a service area freely placed in the room. The placing of this service area divides the room into two different zones, which can be used for other functions. The private outside space, the terrace, is on the whole length of the loft and has almost the same length as depth. This terrace can be used for multiple functions, because of its depth. The privacy on these terraces is a problem for the inhabitants, because the inhabitants of the dwellings above this one can look from their balconies on these private terraces. It is also a problem that the division walls between the different terraces are not so high, and therefore it is possible to look into the private outside space of the neighbours.

The inhabitants of this dwelling can rent an office space on the first floor of the building. The most important function of this unit is living, and that is the reason why this dwelling can be seen as a 'live-work nearby' unit.

LOFT TYPE 2

The second loft type in this building is also one big open space with a service area freely placed in the room. The placing of this service area divides the room into three different zones, which can be used for other functions. This dwelling has a private balcony, which can only be used by two people at the same time due to its size. The privacy on these balconies can be a problem, because the railings of the balconies are not so high and therefore you can look into the private outside spaces of the neighbours. This privacy problem is partly solved by the distance between the balconies, which improves the privacy for the inhabitants.

The dwellers can rent one of the office spaces on the first floor of the building. This dwelling can be defined as a 'live-work nearby' unit, due to the fact that living is the most important function in this unit.

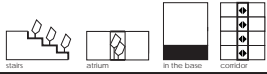

MAISONETTE TYPE 1

The first maisonette type contains three different functions on three different storeys. The entrance of this dwelling, which is on the middle floor, gives direct access to the working and living space. The service area divides this space into three different zones: working zone, eating zone and living zone. The working zone on the middle floor, which is situated directly after the entrance, is connected via a void with the working area on the upper floor. The sleeping area is on the lower floor.

The working area is a small part of the dwelling unit and the entrance of the dwelling is located on the side of the working zone. This dwelling type can be defined as 'live-work with', because the living zone and working zone are in the same room, without any separation.

The working area on the upper floor gives access to the private outside space of the dwelling, the terrace. This terrace is big enough to use the outside space for multiple functions. The privacy on the terraces is high, because the terraces of the different dwellings are separated by a high wall.

MAISONETTE TYPE 2

The second type of the maisonettes is two storeys high. The entrance of the dwelling is on the lowest floor and gives access to the living and sleeping spaces. The working activities take place on the upper floor. This dwelling can be defined as 'home occupation', because the working activities are a small part of the dwelling unit, the working area is separated from the living area and the entrance gives direct access to the living area and not to the working area.

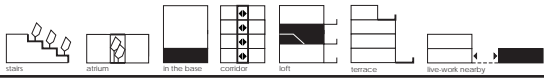

WAREHOUSES

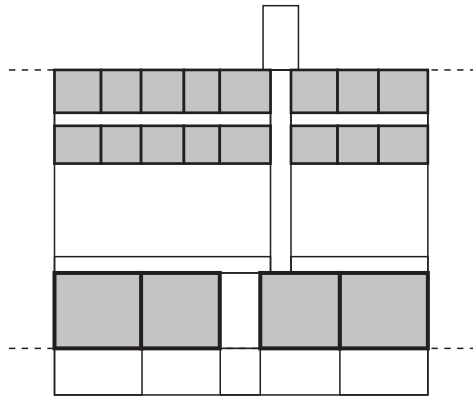

First floor

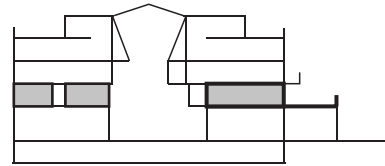

Cross section

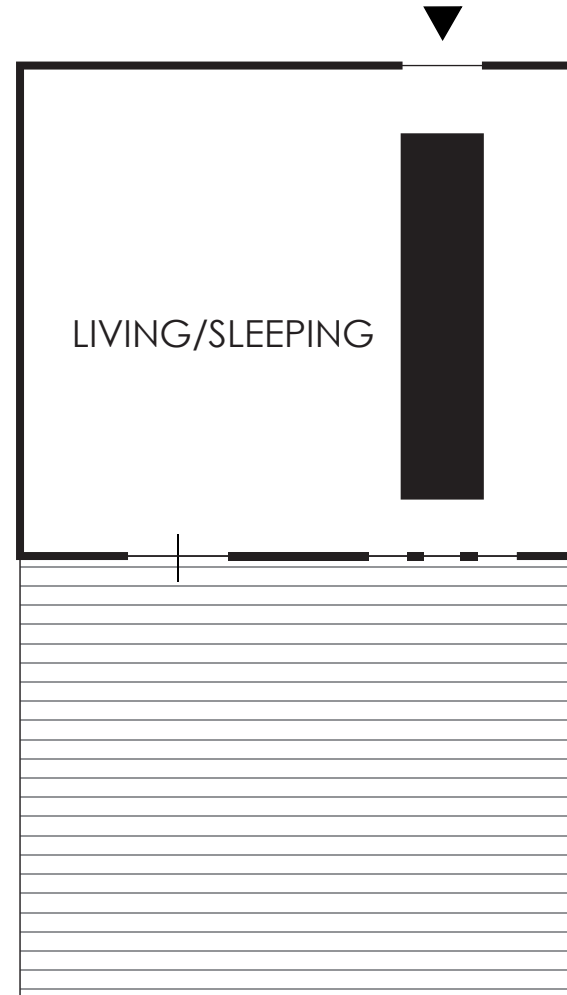

Loft type 1 floorplans and sections scale 1:1000 & 1:150 (own illustration)

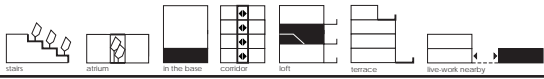

WAREHOUSES

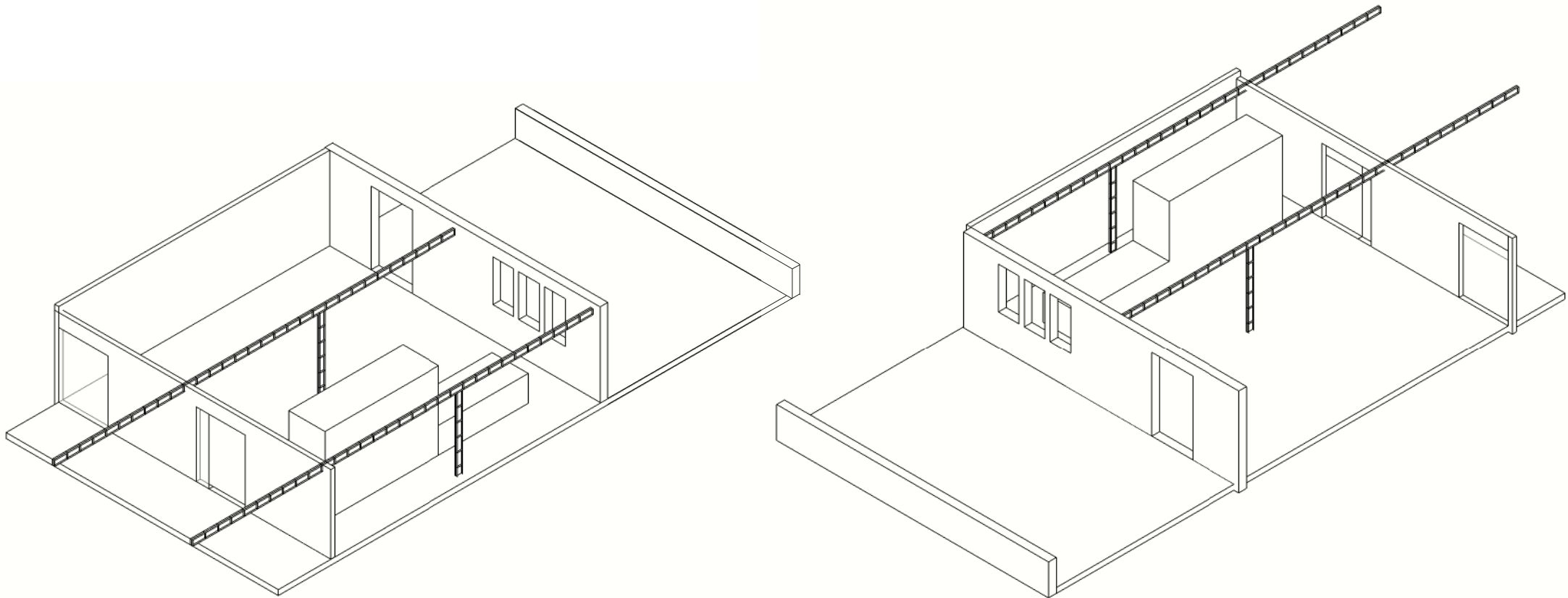

Loft type 1 axonometry scale 1:150 (own illustration)

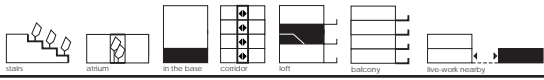

WAREHOUSES

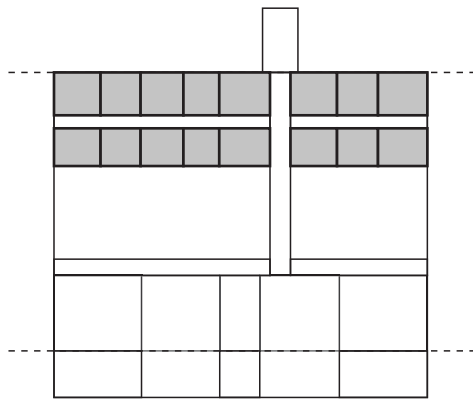

First floor

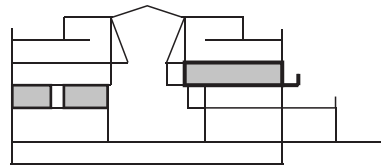

Cross section

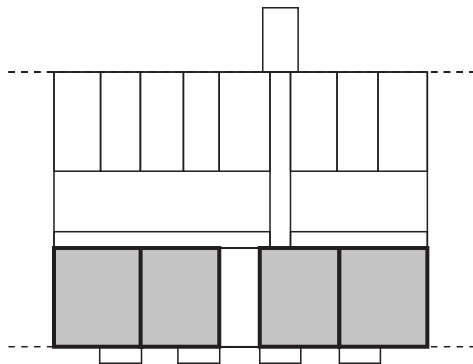

Second floor

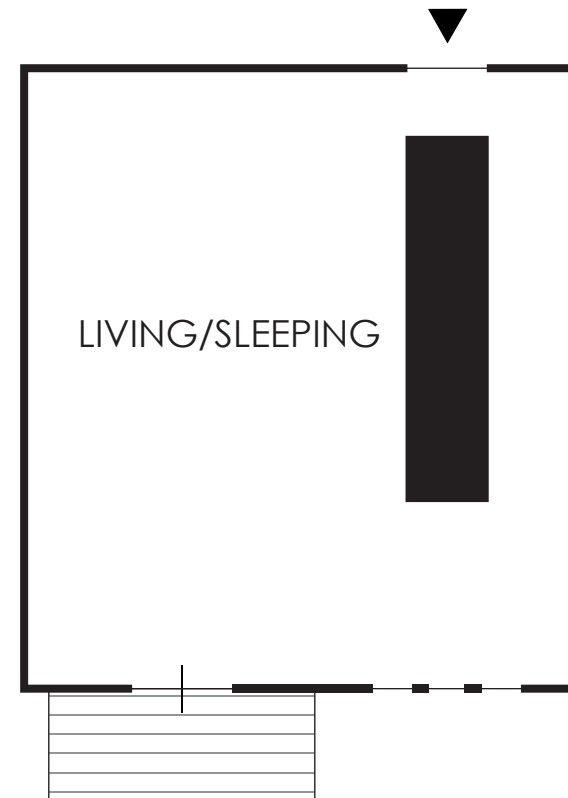
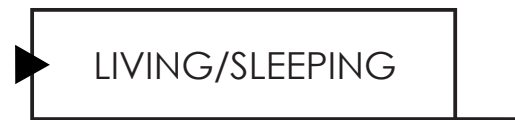

Loft type 2 floorplans and sections scale 1:1000 & 1:150 (own illustration)

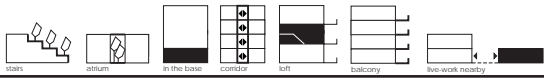

WAREHOUSES

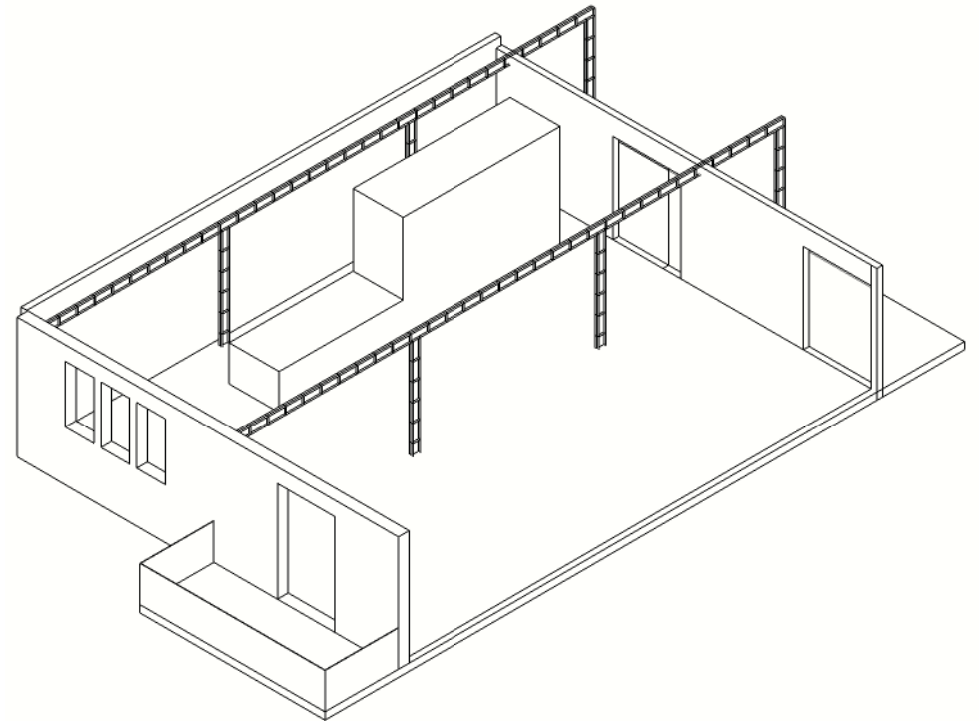
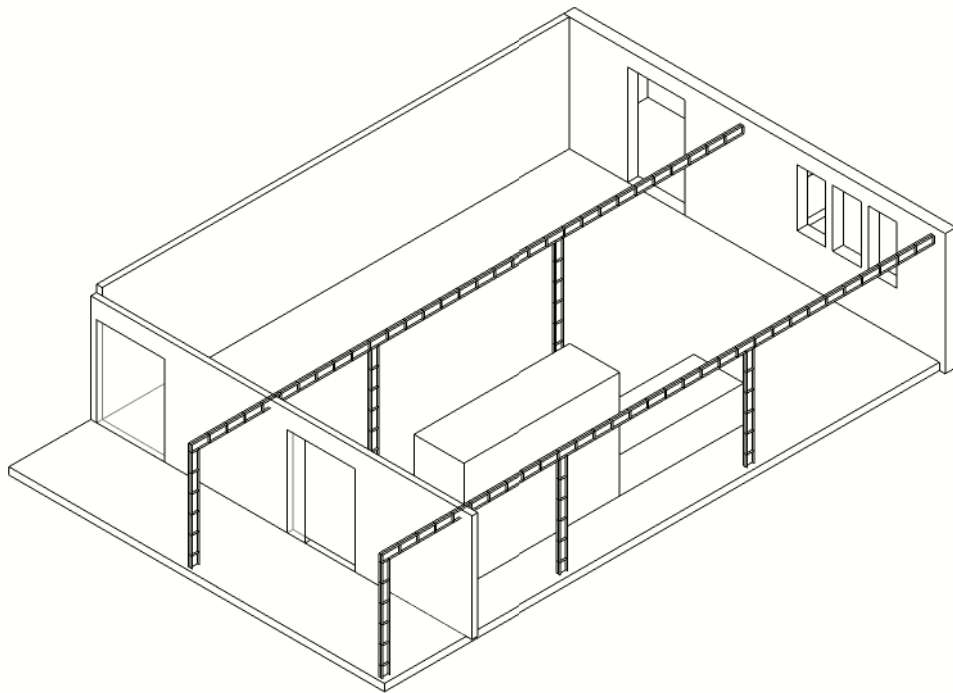

Loft type 2 axonometry scale 1:150 (own illustration)

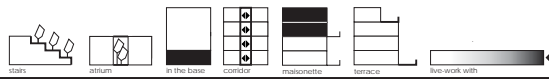

WAREHOUSES

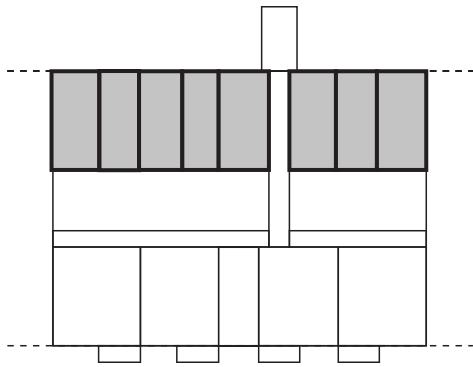

Second floor

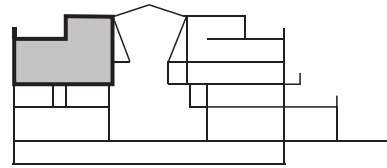

Cross section

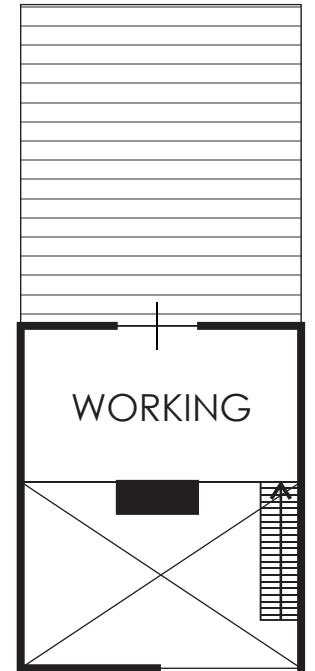
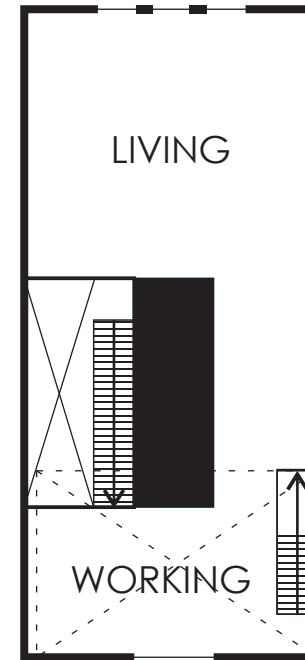
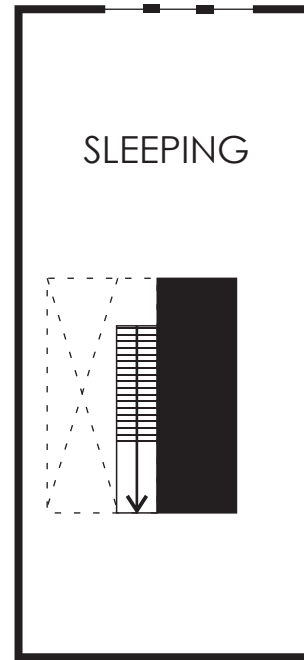
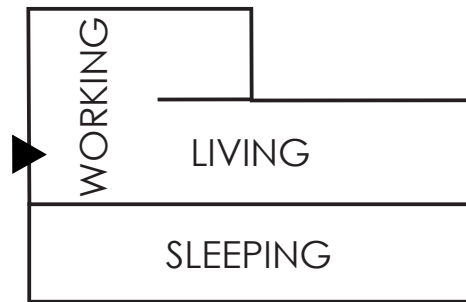

Maisonette type 1 floorplans and sections scale 1:1000 & 1:150 (own illustration)



WAREHOUSES

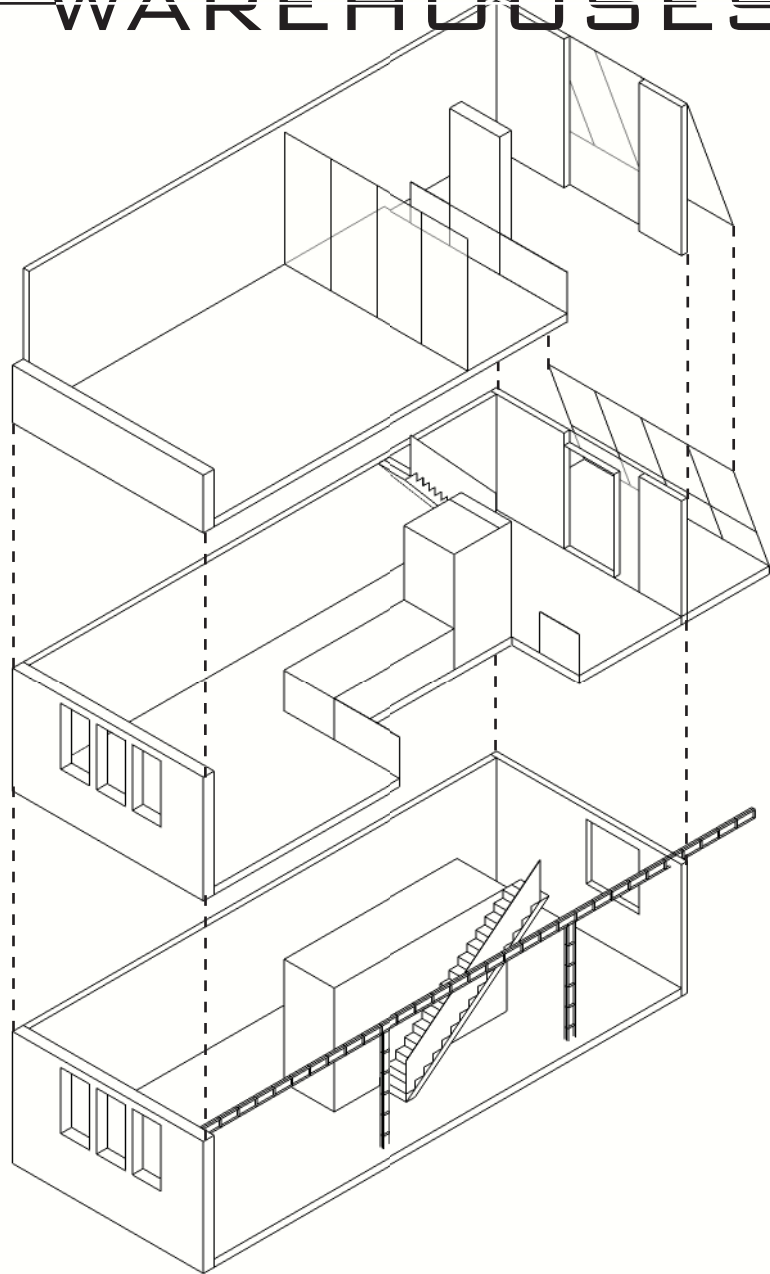
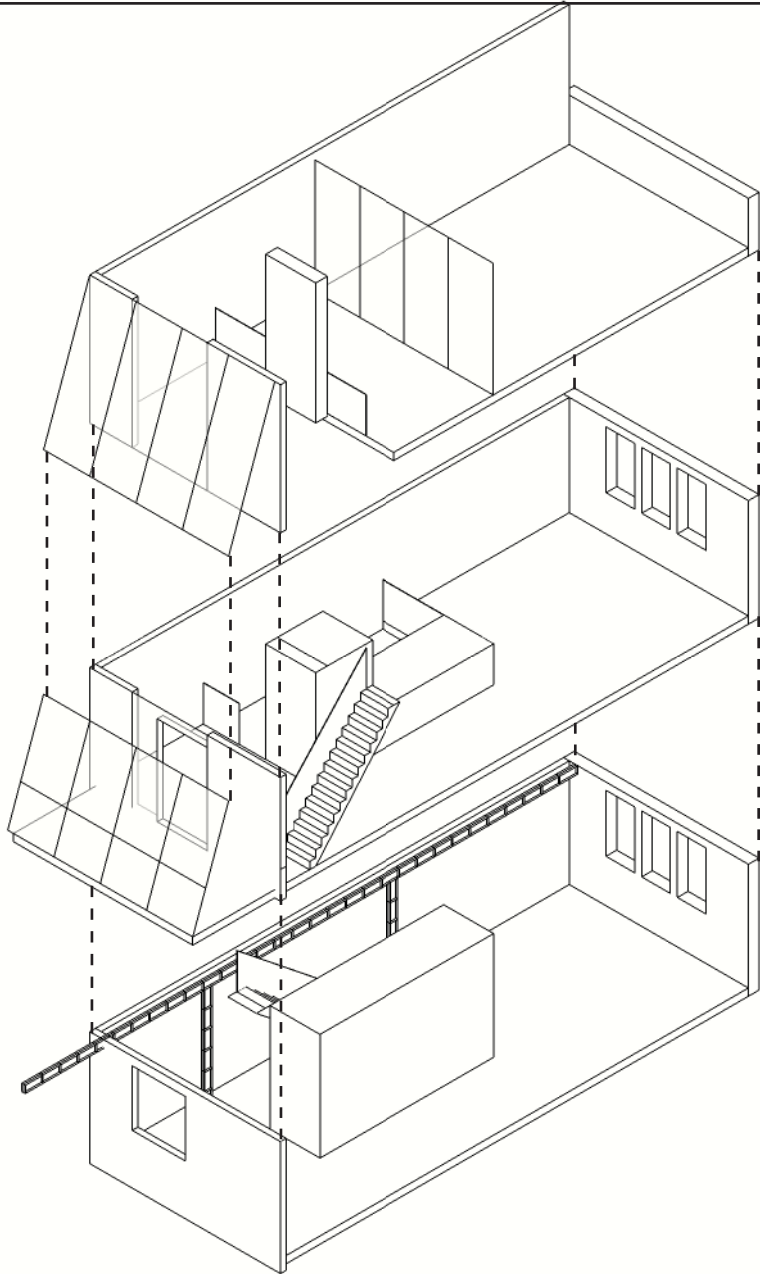

Maisonette type 1 axonometry scale 1:150 (own illustration)

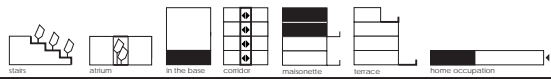

WAREHOUSES

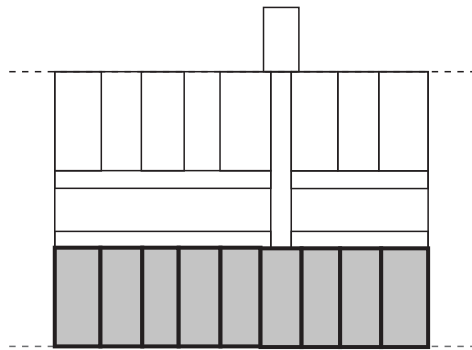

Third floor

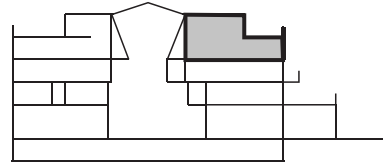

Cross section

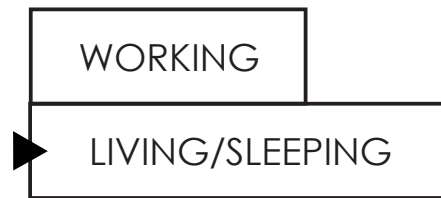

LIVING
SLEEPING

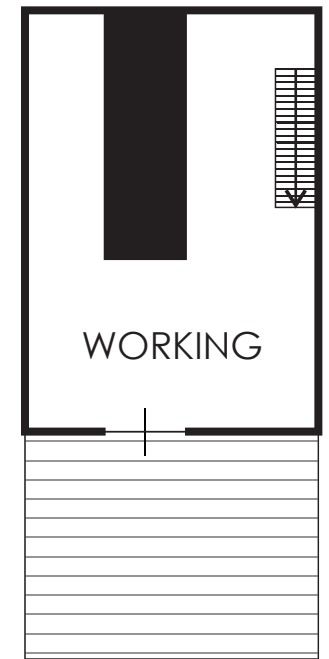

WORKING

Maisonette type 2 floorplans and sections scale 1:1000 & 1:150 (own illustration)

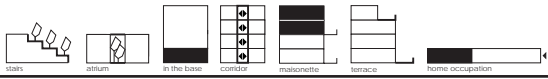

WAREHOUSES

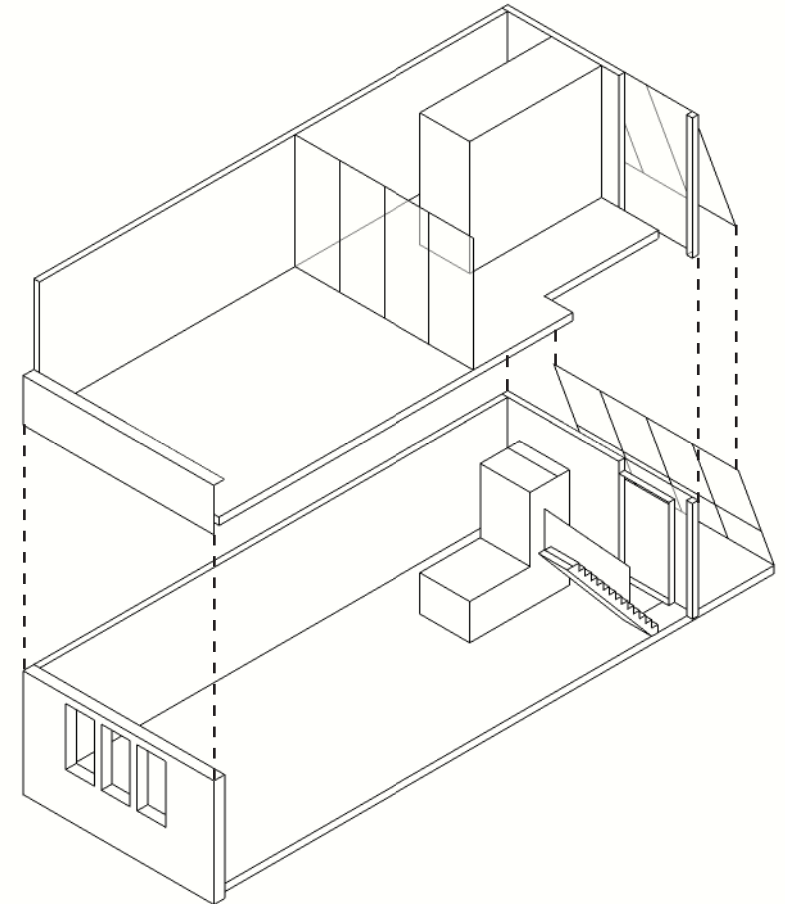
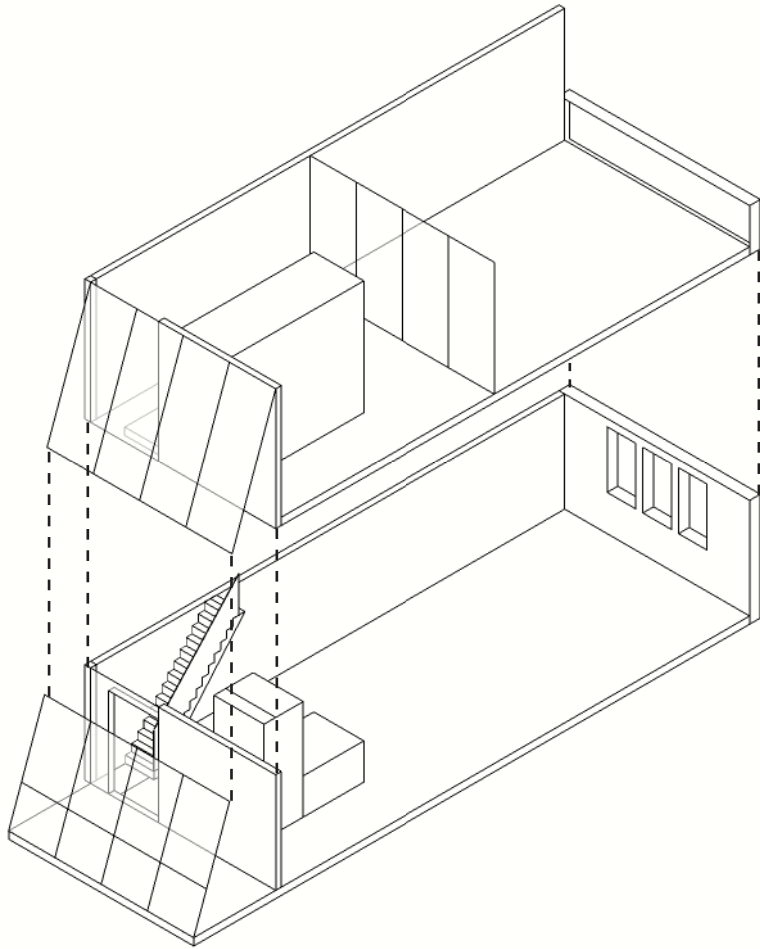

Maisonette type 2 axonometry scale 1:150 (own illustration)

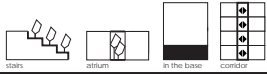

WAREHOUSES

DAYLIGHT

In the current building regulations it is not allowed to build dwellings with a depth of 13 meters, because of the lack of daylight. The dwellings in re-used buildings can have a depth of 13 meters and it needs to be mentioned that people do want to live in these relatively dark dwellings. What is the reason that people want to live in these relatively dark dwellings? Is it necessary to change the maximum depth of dwellings in the current building regulation? The dwellings on the south side have light almost all day, all year. The fact that dwellings have small windows is compensated by the height of the spaces and by the additional windows in the inner-walls along the atrium.

INTERIOR

The interior of all the dwellings contain structural elements of the old building. These elements, which are columns and beams, divide the room in different parts. Besides that, these structural elements characterize the dwellings in this building, as can be seen in the upper image. The other image shows how the open space of the dwelling unit is used and divided into different space.

OUTSIDE SPACE

Every dwelling has its own private outside space on the outside facade of the building, and therefore there is almost no connection between the people in the atrium and the inhabitants of the building.

Since the building is a long and relative slim slab, it has two main orientations: south and north. Most dwellings are orientated on the south side, because this side is the most appropriate one for outside spaces. In order to make maximum advantage of the sun, the old shipping platform of the building is used as terraces for the bottom lofts. The lofts on top have just small balconies, which are added to the building later on, to maintain the qualities of the outside space underneath. The top maisonettes took advantage of the new constructed roof, because these dwellings have gained a roof terrace. There is a minimum of 'roof surface' above the outside spaces, which maximises the amount of sunlight. The counter part of this built-up is that it lacks privacy.



WAREHOUSES

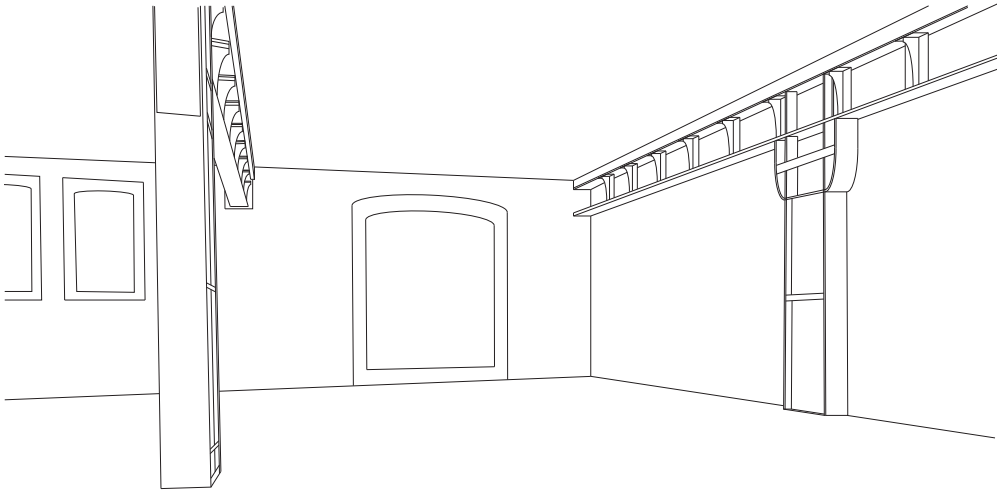

Interior dwelling (own illustration), (Funda, 2012)

CONCLUSION

Due to their characteristic facade, simple inner structure and large building envelope warehouses are grateful buildings for transformations. For their form and structure they are also easy to manage. Warehouses have been re-used for many other new functions. When the new function is a residential one, the most important feature to take care of is daylight penetration. The way to achieve this within a big building envelope is by adding an atrium or courtyard.

When the warehouse is relative slim, as in Jobsveem, atriums can be placed in the width of the building. This results in a building with additional functions in the base and loft type dwellings on top of it, along corridors which have their origins in the atria. Outside spaces have the form of balconies.

When the building is somewhat wider, as in the Entrepot, the atrium can be placed in the length of the building. This results in a building with again additional functions in the base and dwellings on top. These loft and maisonette type dwellings are also accessed by corridors. These are situated along the atrium and in that way are more spacious. The outside spaces have the form of terraces.

When the building becomes really wide; over 50 meters, a courtyard will be an outcome. Hereby the core of the building will be gutted out completely; in a way spaces for dwellings are left along the facade. The result is a building with additional functions in the base, with again dwellings on top. These loft and maisonette type dwellings are accessed by galleries. The outside spaces have the form of terraces which, when placed in-between dwelling and gallery, results in the gallery becoming a deck. When all circulation and outside spaces are directly surrounding the courtyard, it enlarges the sense of community; even more than with atrium type buildings. Privacy is partly at stake, because the building is orientated inward, which is typical for a courtyard type building.

WAREHOUSES



Atrium in the width

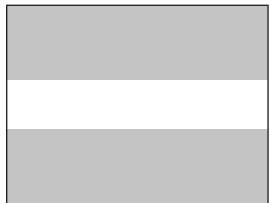
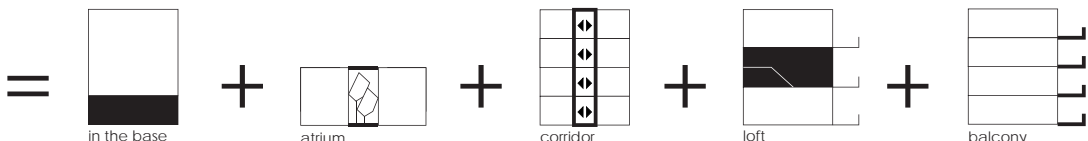

Atrium in the length

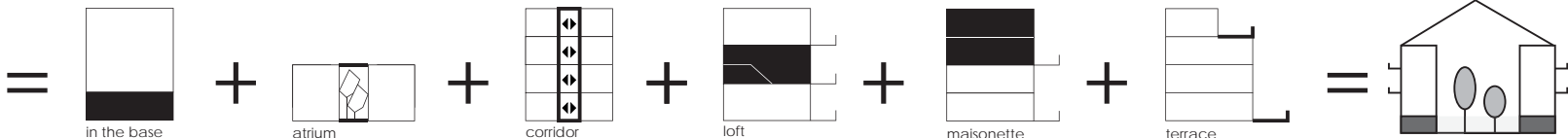

Atrium
Closed inside

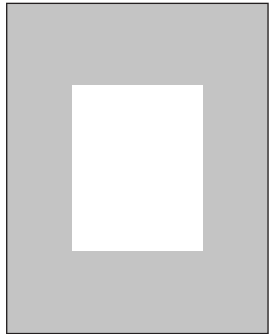

Courtyard

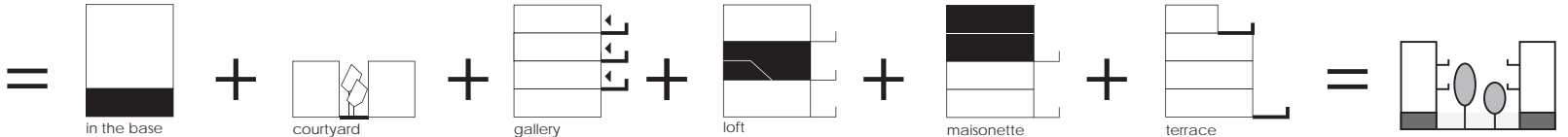

Courtyard
Open inside

Conclusion warehouses (own illustration)

WAREHOUSES

Conversions of warehouses to courtyard type buildings show a lot of similarities with the courtyard type buildings as described in the previous chapter. The comparison with the original courtyards is also easily made. The potential of the conversion is within the scale of the warehouses, combined with their structure. These give a lot of freedom for rearranging, which make these buildings really flexible.

Atrium type of buildings are not often used for residential purposes. The converted warehouses however, show that there is actually a lot of potential within these buildings, unless the infill of the base and atrium are good to combine with a housing program. When this is true, the additional functions enliven the building, leading to a richer living environment.

Maybe most interesting in converting warehouses to a dwelling program, are the dwellings themselves. Lofts are almost typically dwelling types for converted warehouses. The fact that there are no room dividing elements is compensated by structural elements which insinuate room divisions. Hereby the spaciousness of a loft is bigger than in a standard apartment, when at the same time different spaces can be defined. The placement of a service core is here of great importance. Lofts have a maximal flexibility and thereby there is a lot to learn from this dwelling typology.

FOOTNOTES

1. KALK, E. 2010. *Nieuw leven voor meer gebouwen. Hergebruik kan sneller en beter*, Amsterdam, Stichting Agora Europa, (p. 52).
2. Ibidem (p. 54).
3. Ibidem (p. 43).
4. Ibidem (p. 42).
5. Ibidem (p. 54).
6. Ibidem (p. 42).
7. Ibidem (p. 42).
8. Ibidem (p. 43).
9. Ibidem (p. 44).
10. Ibidem (p. 43).
11. Ibidem (p. 45).
12. CANTACUZINO, S. 1989. *Re/Architecture. Old buildings/New uses*, London, Thames and Hudson, (pp. 88-91).
13. Ibidem (pp. 189-190).
14. Ibidem (pp. 88-91).
15. Ibidem (pp. 189-190).
16. Ibidem (pp. 88-91).
17. Ibidem (pp. 88-91).
18. Ibidem (pp. 189-190).
19. CANTACUZINO, S. 1975. *New uses for old buildings*, London, The Architectural Press Ltd, (p. 189).
20. Ibidem (p. 190).
21. KALK, E. 2010. *Nieuw leven voor meer gebouwen. Hergebruik kan sneller en beter*, Amsterdam, Stichting Agora Europa, (p. 57).
22. Ibidem (p. 57).
23. Ibidem (p. 53).
24. Ibidem (p. 57).
25. BURO VAN STIGT S.D. *Graansilo's*, Amsterdam, (p. 21).
26. KALK, E. 2010. *Nieuw leven voor meer gebouwen. Hergebruik kan sneller en beter*, Amsterdam, Stichting Agora Europa, (p. 57).
27. Ibidem (p. 57).
28. Ibidem (p. 46).
29. Ibidem (p. 46).
30. CANTACUZINO, S. 1975. *New uses for old buildings*, London, The Architectural Press Ltd, (p. 189).
31. KALK, E. 2010. *Nieuw leven voor meer gebouwen. Hergebruik kan sneller en beter*, Amsterdam, Stichting Agora Europa, (p. 30).
32. CANTACUZINO, S. 1975. *New uses for old buildings*, London, The Architectural Press Ltd, (p. 190).
33. KALK, E. 2010. *Nieuw leven voor meer gebouwen. Hergebruik kan sneller en beter*, Amsterdam, Stichting Agora Europa, (p. 30).
34. BAKKER, M. 1996. *Schoorconstructie in drie dimensies zekert stabiliteit van veempand; breedplaten slim in historisch skelet verwerkt*. *Bouwwereld*, 92, 26-31, (p. 28).
35. KALK, E. 2010. *Nieuw leven voor meer gebouwen. Hergebruik kan sneller en beter*, Amsterdam, Stichting Agora Europa, (p. 54).
36. CANTACUZINO, S. 1975. *New uses for old buildings*, London, The Architectural Press Ltd, (p. 189).
37. Ibidem (p. 241).
38. Ibidem (p. 189).
39. KALK, E. 2010. *Nieuw leven voor meer gebouwen. Hergebruik kan sneller en beter*, Amsterdam, Stichting Agora Europa, (p. 55).
40. Ibidem (p. 54).
41. Ibidem (p. 56).
42. Ibidem (p. 30).
43. Ibidem (p. 54-55).
44. CANTACUZINO, S. 1975. *New uses for old buildings*, London, The Architectural Press Ltd, (p. 189).
45. VAN HULTEN, A. 1985. *Werkstad: 30 industriële monumenten in Rotterdam*, Rotterdam, Stichting industrieel erfgoed Rijnmond, (p.33-36).
46. WORTMANN, A. 1997. *200 meter stad: het Entrepotgebouw op de kop van zuid*. *Archis*, 64-68, (p.64-68).

CYLINDRICAL BUILDINGS



Cylindrical silos (MVRDV, 2005)

HISTORY

One way to store products is in warehouses. With developing techniques in the building sector, and developing techniques for ventilating buildings and goods, these became higher. Higher buildings also meant that the floor surface of the buildings could become smaller. This resulted in tower shaped buildings for storing goods, which were named silos. Here, granular and powdery goods are stored. For their function they are built along or near the waterfront of canals and harbors, or on other transport nodes; like next to a railway.¹

Most of the silos are built from the 1950's due to rising demands for extra storage. These silos are often arranged in groups; hiding several silos behind one rectangular shaped envelope; like the 'Graansilo's' in Amsterdam, resulting in a slab formed building.² These silos have a lot of similarities to the warehouse type of building, because they are evolved from it. They are a type in-between the standard warehouses and the standard watertowers. These 'Graansilo's' have already been spoken in the chapter of the warehouses.

This chapter considers free standing silos; resulting in tower shaped buildings. Most of the time these free standing silos are cylindrical shaped and have their origin in the 1960's. Their shape made it possible to use the smallest amount of building materials for the biggest amount of space. At the same time this shape prevented goods from being left behind in the corners of the building and therefore the shape was more hygienic than its previous form.³ This chapter primarily considers cylindrical buildings, because it considers a whole new type of building form.

Since the beginning of the 19th century, there were already two other types of cylindrical buildings, which were named watertowers and gasometers. These two types of cylindrical buildings are descendants of the industrial revolution.⁴ Watertowers were built for keeping up the pressure in the new built water systems.⁵ Gasometers were not meters for gas, as the name suggests, but were containers for gas. It is the same as the watertowers, gasometers needed to keep up the pressure in the new built

CYLINDRICAL BUILDINGS



Rectangular, free standing, tower shaped silos (Ecofriend, S.D.)

gas lines.⁶

In the end of the 1970's, watertowers and gasometers became gradually unused with further developing technics in the water household and in the gas industry.

The same happened for the silos. Industrial activities were replaced from the inner cities to the outskirts of the city, due to governmental policies. The inner city silos became vacant due to changing requirements for transportation and fire safety.

Cylindrical buildings are hard to re-use due to their shape and structural skins. The recent interest in the preservation and redevelopment of old industrial buildings and sites however gives opportunities for preserving these buildings. This cannot be considered apart from wider economic and societal trends. One of these trends is that governmental policies realize a large part of the housing assignment within the boundaries of the city and no longer in the growth cores. Another trend is the arising of creative industries, which is a collective term for companies and institutions in arts, creative services and media & entertainment.

CHARACTERISTICS

Everywhere in Europe, old inner city harbor sites are being reconverted into high-quality living areas. *"Excellent views, waterfronts, proximity to the city center and an original character make most of these developments instant successes."* (MVRDV, S.D.) The most popular projects are usually converted warehouses that combine a modern lifestyle with a touch of character.

The conversion of silos also fits into this picture although it can be considered as a more radical next step. Warehouses can be seen as more or less complete buildings. These include an already

CYLINDRICAL BUILDINGS



Gasometers of steel (Gasometer Oberhausen, 2013)

existing inner structure and a characteristic facade. They should be modestly treated, not to lose its original charm. Silos, in the form of tower shaped cylindrical buildings, are incomplete bare structures. They have no inner structure, nor a characteristic facade. In this incompleteness lies the challenge of the conversion.

Silos, as referred to in this chapter, can be cylindrical or rectangular shaped towers. Their floor surface is smaller than their height; which is mainly around 50 meters. This makes these buildings landmarks. For their urban value, they are wanted to be preserved, even when their structure does not make this an easy task.

Cylindrical silos have a structure which is formed by their building envelope. This envelope consists out of concrete, but can also be made of steel, aluminum, plastic or textile. The silos suitable for conversion are made out of concrete, because concrete has a high insulation value, whereas steel, aluminum, plastic and textile have a low insulation value, which is not suitable for dwellings. These concrete silos have shells which are quite thick and have no openings in it, because this was not necessary for the storage of goods.

Rectangular, free standing, tower shaped silos are scarce. This is due to the fact that they are an in-between form of the warehouse type silos and the cylindrical silos. Structurally, they have more in common with the warehouse type silos because they have, next to a structural envelope, also an inner structure of cells, with measurements of mainly 4 by 4 meters, and small openings in the facade. However, they are always made out of concrete. In combination with their form, their conversions are more similar to the conversions for cylindrical silos. That is why they are mentioned in this chapter.

Gasometers are more easily to convert. Gasometers are always cylindrical. The structure consists always out of a concrete basin or

CYLINDRICAL BUILDINGS

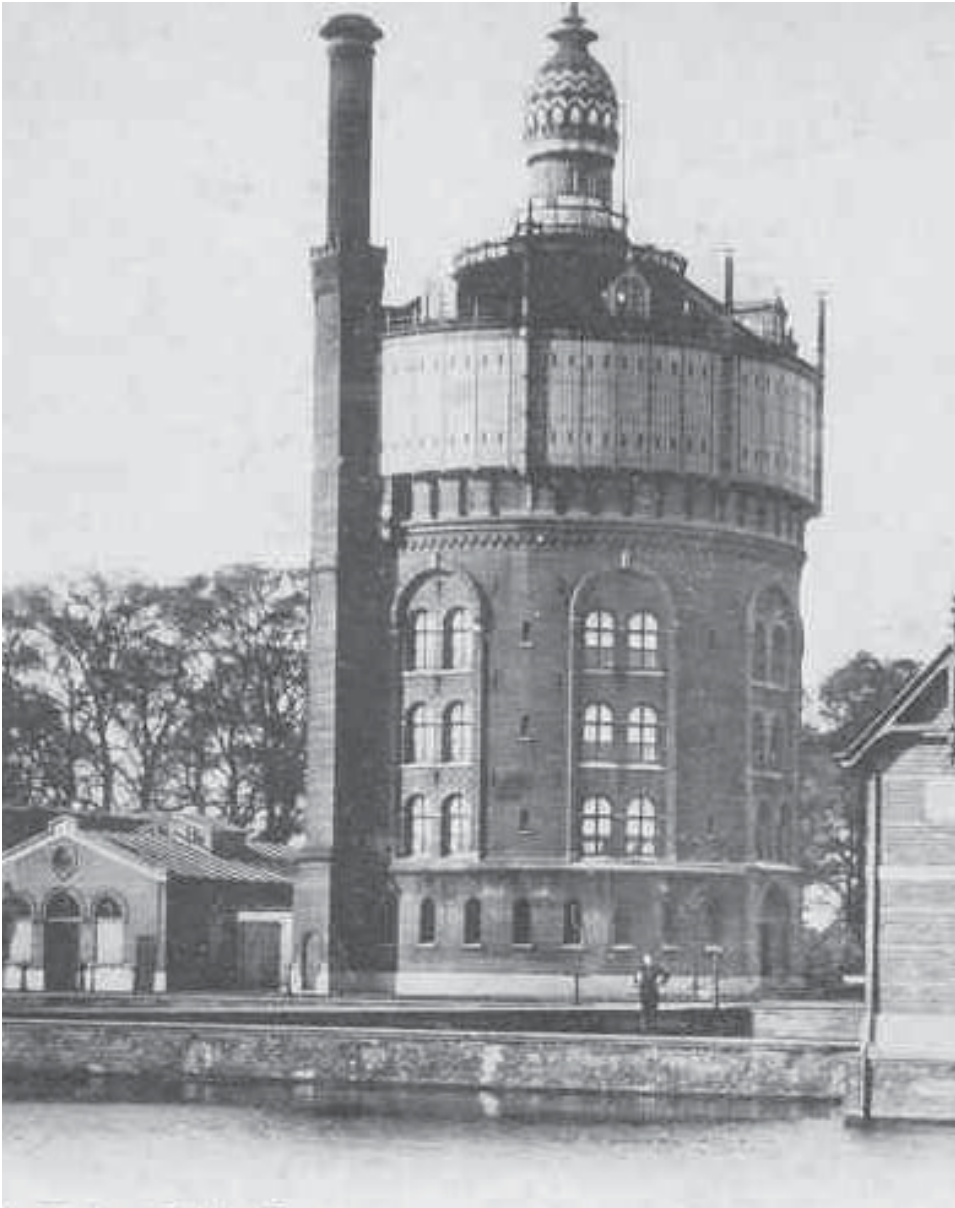

Watertower on the Esch complex in Rotterdam (Van Hulten, 1985)

base, with on and/or around it only an empty shell. This shell can be a steel structure and/or a brick shell.

The **Gasometers of steel** show great similarities to the cylindrical shaped silos. Their sizes, structure and facade are mainly equal.

Gasometers with a brick shell often do have openings in the facade. This makes their conversion more easily. Still the heights of these Gasometers are equal to the silos. The floor surface however is most of the time bigger; almost equal to their height. This mainly leads to different solutions by conversion.

Watertowers are most easily to convert. Since the end of the 1970's, when these buildings became vacant, these buildings were converted, by squatters at first, for creative and residential uses. One of the first examples of this in the Netherlands is the **Watertower on the Esch complex in Rotterdam**.⁷

This has everything to do with their size, inner structure and facade. Their height is equal to the other types of cylindrical buildings. Their floor surface however is smaller. At the same time, most watertowers have had also a residential function next to the function of watertower. Therefore most watertowers, suited for conversion, have characteristic brick facades with openings for daylight penetration. It also implies that most watertowers already had an inner structure of floors, next to its structural cylindrical shaped shell.

The small scale of the watertowers made it easy for squatters to manage the buildings. At the same time, the already existing floors and facade openings made it possible to occupy them without any large conversions. Also their diameter is excellent for residential purposes.

CYLINDRICAL BUILDINGS



Suikersilo's in Halfweg (Soeters Van Eldonk Architecten, S.D.)



Frøsilos in Copenhagen (Nielsen, 2010)

ADAPTATION

Mainly in Holland and Denmark, there is quite a number of inner city located industrial silos, of which most are no longer in use. Still they characterize the skyline. Their structural limitations make it hard to convert and maintain these buildings. At the same time this can hold the solution for the intervention. Making big openings in the concrete shell of a silo, for windows and doors, is possible but complicated and can only be made in limited amounts. If there were functions to be situated in a silo this would mean that, for most of the conversions, views to the outside are limited.

Therefore the **Suikersilo's in Halfweg**, next to the canal in-between Amsterdam and Haarlem, are converted into offices. These silos give the impression of having a lot of openings in the facade. However, half of the 'openings' are fake.⁸

If there were apartments to be situated in a silo, this would mean that in an area where views or daylight penetration are important, the apartments are inwardly directed. For a warehouse this might be acceptable, due its monumental status. For a silo it is a missed opportunity. At the same time, if you would fill up the silo with houses and floors, it would destroy the most exciting aspect of its present state: its emptiness.

By flipping the projected floors to the outside, this potential problem is eliminated, and turned into an advantage. Maximum views are possible and a maximum of flexibility can be achieved. This is done by the **Frøsilos in Copenhagen**. MVRDV have chosen to hang the apartments on the outside of these silo walls as a second skin of glass. This very light structure created almost outdoor living spaces. The hollow cores of the two silos remained as an industrial version of the atrium. They are used for the infrastructure of the building; stairs, elevators and galleries. The two rotundas are capped with a translucent, plastic roof for daylight penetration; creating a

CYLINDRICAL BUILDINGS



Siloetten in Løgten, Denmark (Møller, S.D.)



Carlsberg Silo Apartment building (Tivolis Venner, S.D.)

futuristic lobby as tall as the building itself, within which residents and visitors can move up and down.⁹

Both examples have had large interventions on the exterior. The raw concrete has been left uncovered to highlight the origin and history of the structure, at the foot of the silos.

At the **Siloetten in Løgten, Denmark**, more of the raw concrete exterior has been left uncovered. As in Copenhagen, here the apartments are situated on the exterior of the former silo. Also the silo itself is used for circulation. Other than the silos by MVRDV, this silo is rectangular shaped. Their same way of conversion shows the close relationship between the two kinds of silos. At the same time, their differences in shape, made it possible in Løgten to expose more of the original building. For this example, the foot of the silo is reserved for other additional functions to the housing theme.¹⁰

Another project in Copenhagen; the **Carlsberg Silo Apartment building**, exposes the complete shape of the former building. This extreme high former grain silo of 85 meters, with a diameter of 17.5 meters, did realize its apartments on the inside of the building. Although the exterior is not wrapped by apartments, more than half of the original facade was sliced away and replaced to provide the shell with openings for windows.¹¹

Gasometers have better possibilities for conversion to residential purposes. This is due their bigger floor surface and, in the case of a brick facade, characteristic exterior with already openings in it. Most steel gasometers are demolished or re-used for public functions. The picture shown as an example for steel gasometers is situated in Oberhausen and converted into a theater. Thereby the facade did not need any large interventions.¹²

In Vienna four **Gasometers** with a classical brick facade have

CYLINDRICAL BUILDINGS

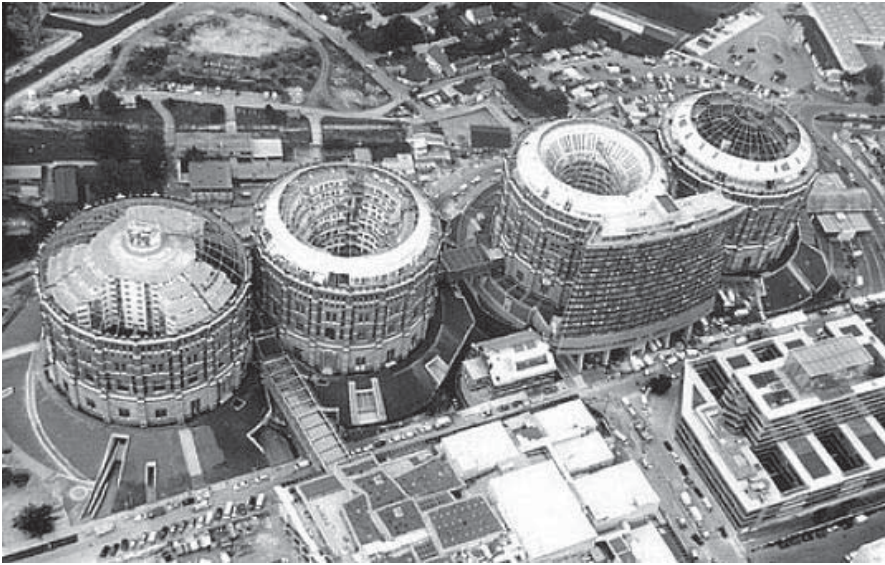

Gasometers in Vienna (Alter, 2010)



Villa Augustus in Dordrecht (Steenhuis & Meurs, 2010, pp. 68-69)

realized a residential program in their insides. The facades are mainly intact, although they needed some renovation. The apartments are placed in the inside, without filling up all characteristic emptiness to preserve the character of the building. The project is done by four different architectural firms, therefore no Gasometer is alike. In the base they do share a shopping mall. For the richness of this project, it is chosen to be the case study for this chapter. Gasometer C shows similarities to the way the silos of MVRDV in Copenhagen are converted, in the way the inner emptiness is preserved, that is why the emphasis of the case study will be on this Gasometer.

Most easily to convert are the watertowers. More and more watertowers are used for a purpose other than for which they were built. Approximately 40 towers in the Netherlands are now in use as home, office, restaurant, museum, or other functions. Other towers are still waiting for conversion. In many cases, this is the best way to preserve the towers when they are no longer needed for their former function.¹³

Since 1978, the watertower on the Esch complex in Rotterdam is in this context re-used for living and working community Utopia. An extension is built to the base of the tower, where the former coal storage was situated, to realize a restaurant. On top of it 6 dwellings are realized in the former dwellings off the workers. Offices are now situated in the old water basin. Logically, in the basin were at first no facade openings. The basin however was removed and the old wooden covers were partly made into shutters, for the new made windows behind them.¹⁴

Villa Augustus in Dordrecht underwent almost the same kind of conversion. Around the tower is an allotment to provide the restaurant in the base with food. To realize this restaurant, the base is provided

CYLINDRICAL BUILDINGS

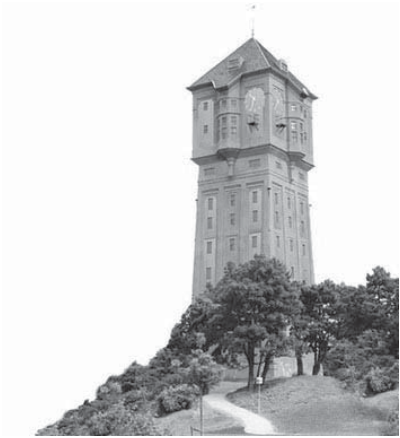

Watertower in IJmuiden (Watertoren IJmuiden, S.D.)



Watertower in Soest (Zecc Architecten, S.D.)

with an extension. On top of it is a hotel. It is partly situated in the former basin, resulting, as in the previous example, in new openings in the facade.¹⁵

In **IJmuiden** its **watertower** was converted into multiple lofts. The floor surface of this watertower is way smaller than the previous examples, and that is why this realization had more extensive alterations as result. The tower had changes in the facade of not only the water tank, but also in the base.¹⁶

In **Soest** its **watertower** was converted into one dwelling. Here, not only the floor surface, but the whole tower is a lot smaller. Therefore mayor transformations in the facade where needed.¹⁷

Although the transformation of the facades for smaller watertowers is bigger than for the bigger ones, the main features of it can always stay intact. For their uniqueness these watertowers are very popular as residences.

CYLINDRICAL BUILDINGS

GASOMETER C



CYLINDRICAL BUILDINGS

GASOMETER C

Name: Gasometer C

Location: Vienna, Austria

Original function: part of the largest industrial gasworks in Europe back in 1899

New function: part of a domed indoor town with a giant community of shops, entertainment, civic, public and garden spaces, hotels and residences

Architects: Schimming, Theodor Hermann, Franz Kapaun (original design), Jean Nouvel (re-use Gasometer A), Coop Himmelb(l)au (re-use Gasometer B), Manfred Wehdorn (re-use Gasometer C) and Wilhelm Holzbauer (re-use Gasometer D)

Area: 2.827 sqm per Gasometer, 11.309 sqm total of all Gasometers

Year: 1892-1899 (original design), 1995-2001 (re-use)

CYLINDRICAL BUILDINGS



GASOMETER C | VIENNA, AUSTRIA | 1995-2001

HISTORY

In 1892 Viennese authorities decided to invest in large-scale gas and electric utilities. Therefore, an international competition was announced for new city gasworks. The construction of these started in 1896. In three years' time, the city built Europe's largest gas plant. This included four cylindrical telescopic gas containers, or Gasometers, and more than 500 km of gas lines. When Vienna converted its gas supply from coal gas to natural gas between 1970 and 1978, the Gasometers became outdated and the technical equipment of the gas tanks was consequently dismantled. The gas plant was permanently shut down in 1986.¹⁸ In 1995 it was decided to utilize these structures for residential purposes.

GASOMETER C

BUILDING ENVELOPE

The Gasometers were gutted during the remodelling. From the original buildings the outer skin of monumental brick cylinders, which are now under protection as monuments of history for their classical design, and parts of the steel roof remained. The brick cylinders have a height of 39.4 meters and a diameter of 60 meters. Considering a water basin in the bottom of the building, this resulted in a total usable volume of approximately 90,000 cubic meters.¹⁹ The total height of the buildings is 70 meters, including basements and a dome.

COMPOSITION

During the transformation of 'Gasmeter C' into a mixed use residential building, 11 new floors were added on top of the basements. These new floors are distributed into 6 vertical blocks. In between these blocks, 4 circulation cores and 2 voids are situated. Due to the narrow voids of approximately 3 meters, the building consists of basically 10 parts. In between the 4 circulation cores, 2 large segments (combining 2 vertical blocks and a void) and 2 small segments are positioned around an atrium, on top of the basement.

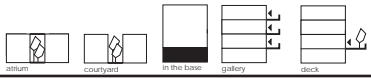

CYLINDRICAL BUILDINGS

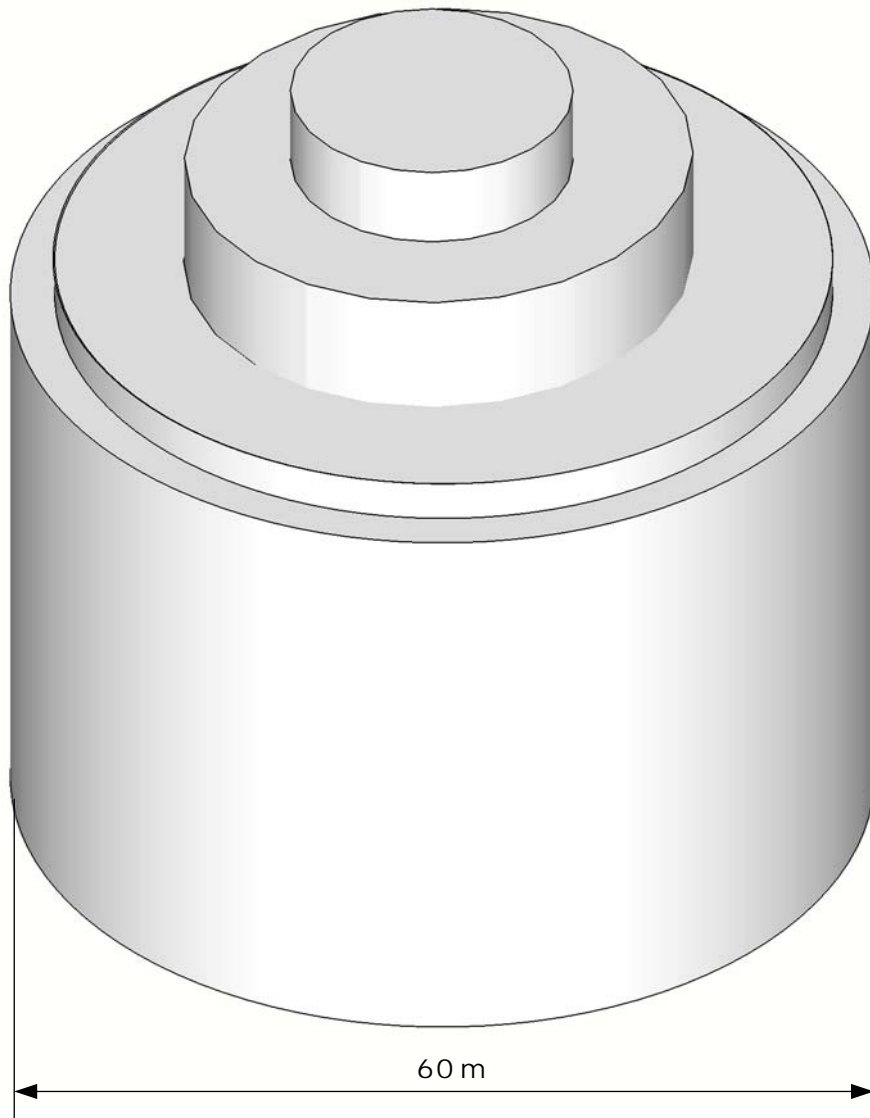

39,4 m

60 m

Building envelope & Composition scale 1:500 (own illustration)

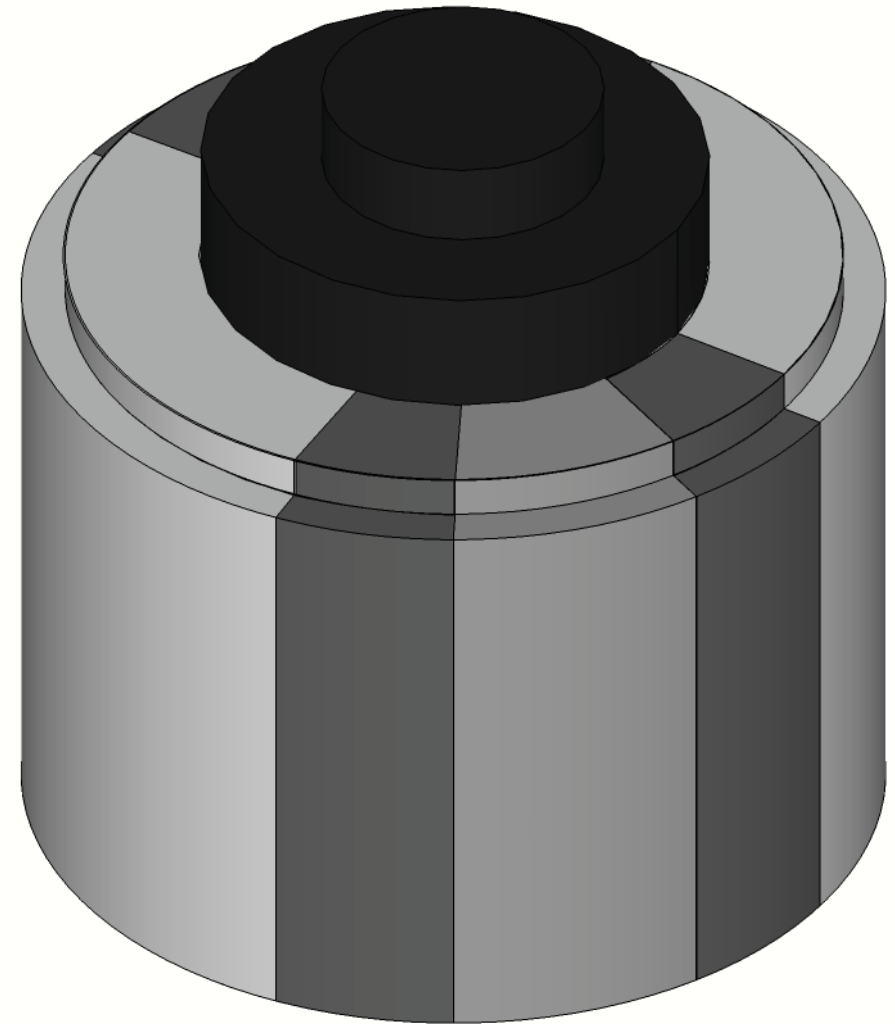

CONTENT

- atrium
- circulation core
- small segment
- large segment

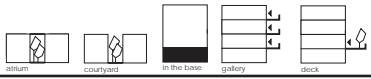

CYLINDRICAL BUILDINGS

Situation

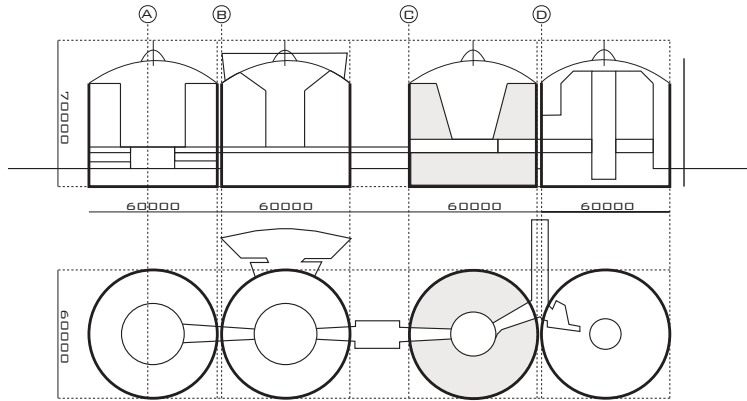

Section

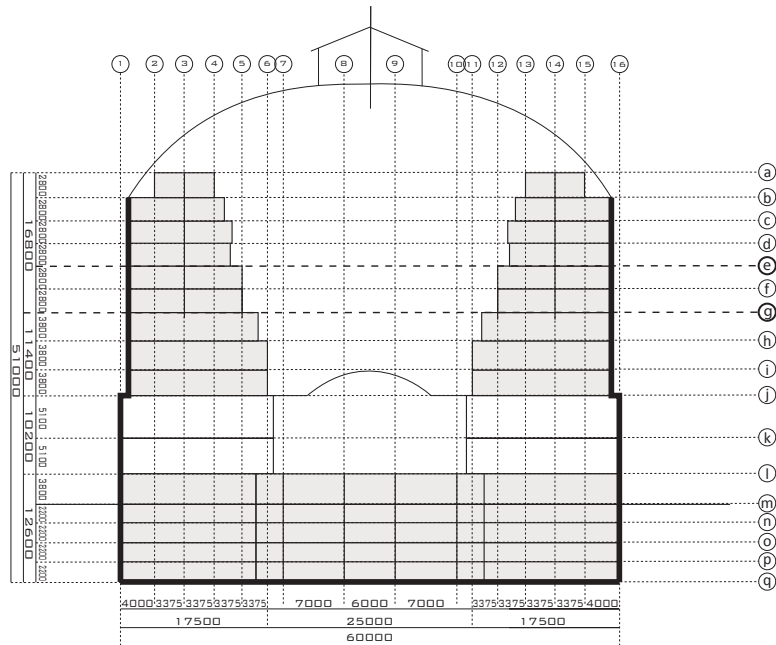

Grid structure (own illustration)

Eighth floor

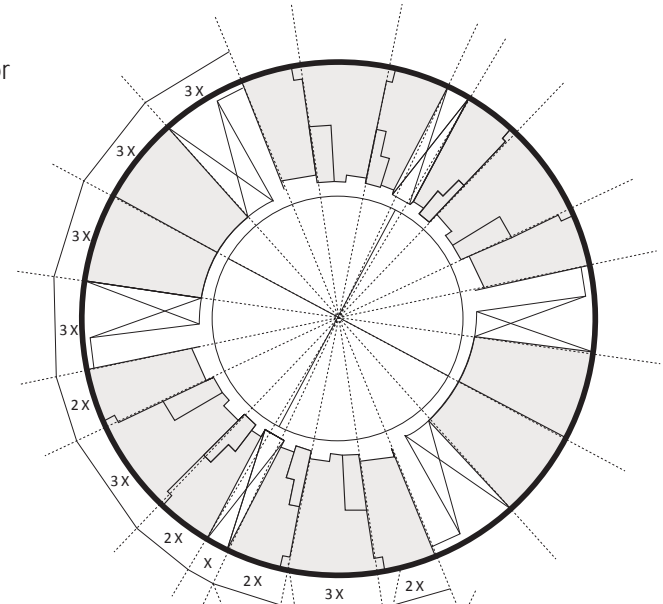

Sixth floor

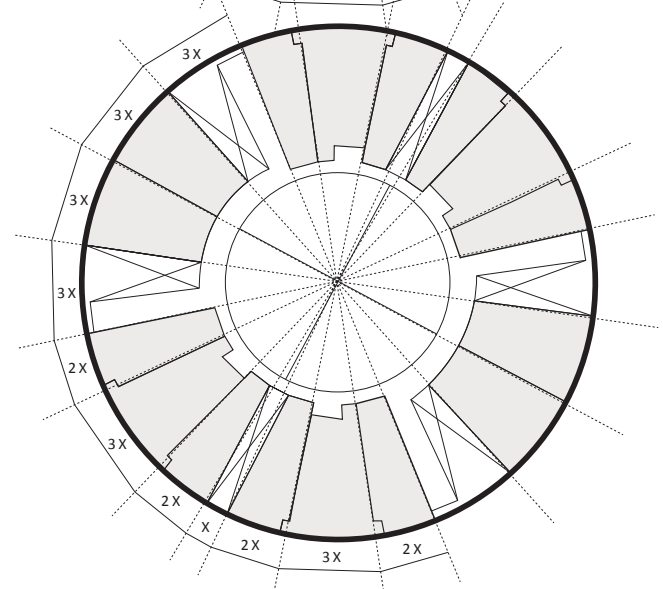

CONTENT

X 3141.6 m

■ functions

□ circulation

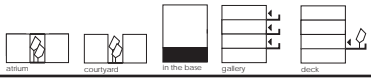

CYLINDRICAL BUILDINGS

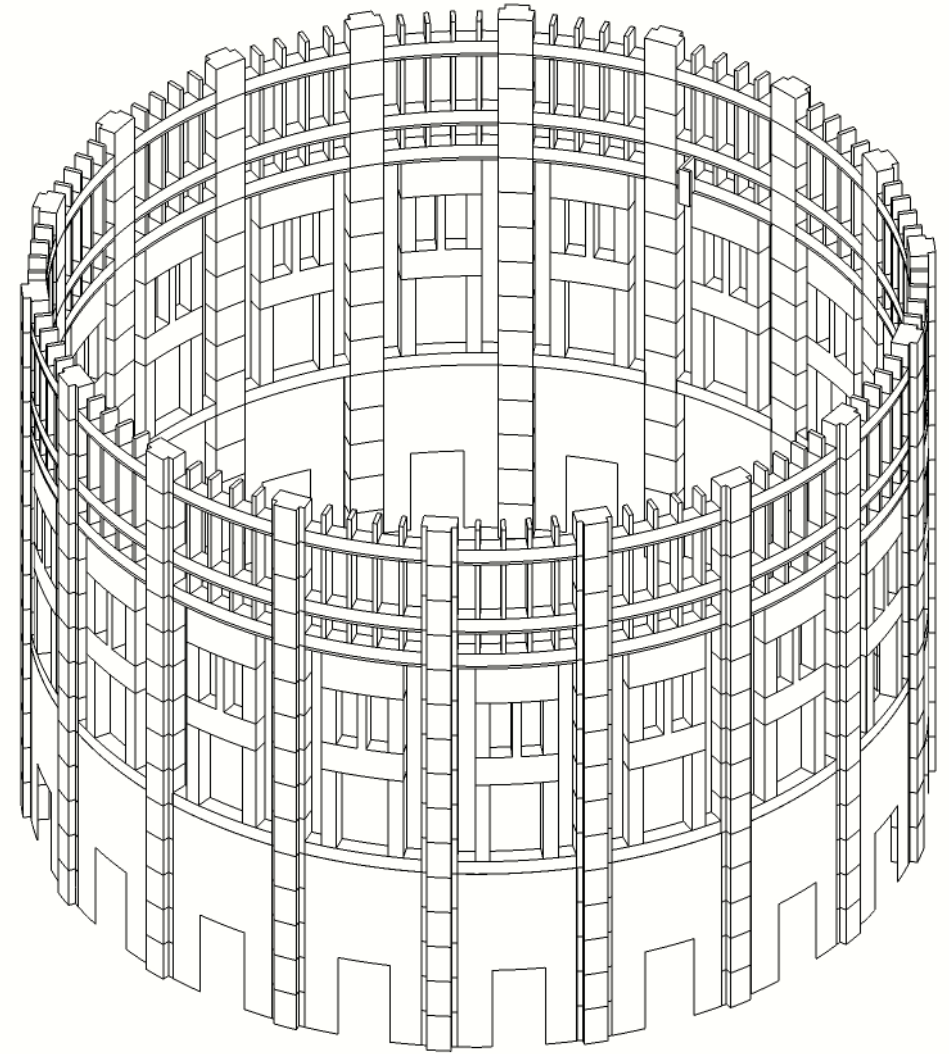
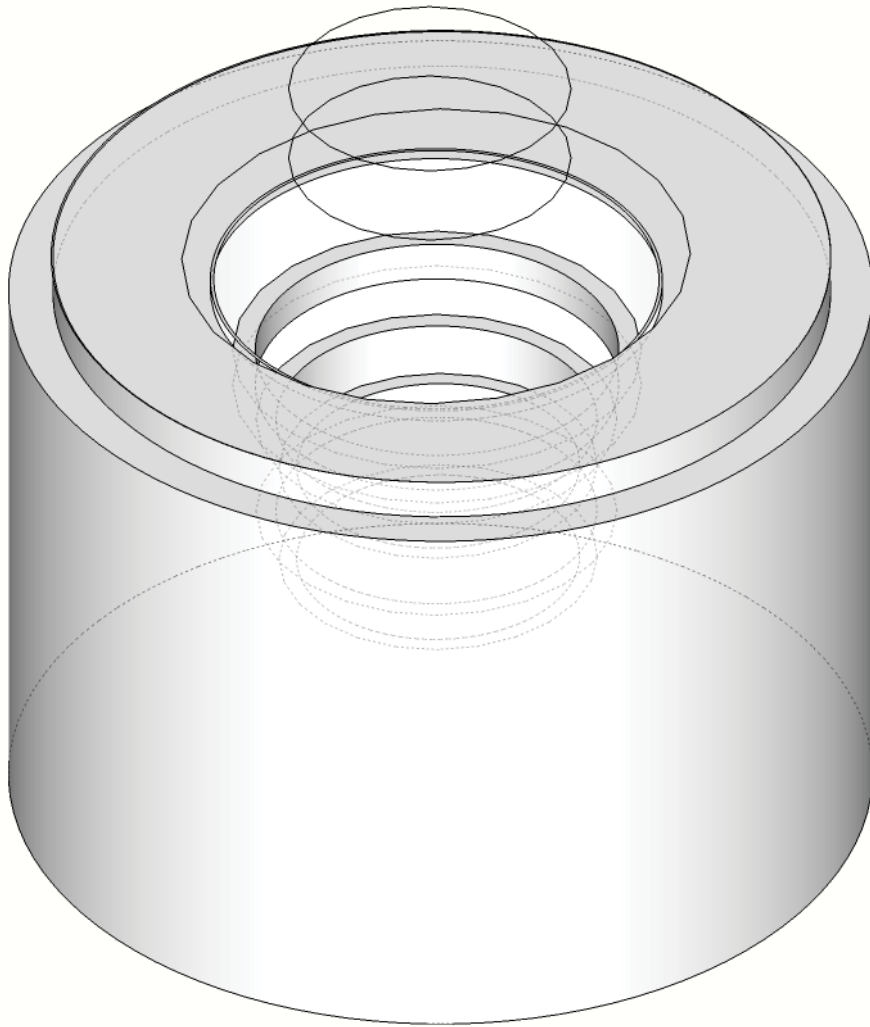

Atrium & Structure scale 1:500 (own illustration)

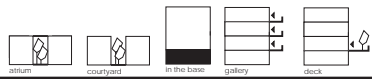

CYLINDRICAL BUILDINGS

The atrium is open towards the sky and because the new in-fill is sloped upward, a higher penetration of the sunlight was achieved downwards. On the bottom, a circle of green, on which several trees were planted, is situated around a glass dome. This dome gives daylight access to a shopping mall in the basement.

Resulting the building looks like an atrium building, but the internal green space could also be recognized as a courtyard because of the open steel roof structure. Underneath the courtyard is than again an atrium of the shopping mall, because this atrium is sealed with a glass dome.

STRUCTURE

The four Gasometers, standing in a row as pairs of two, are identically constructed in brickwork. They are cylindrical constructions with a diameter of 60 metres. A 12.6 meters high ring of brickwork is situated 8.8 meters underneath the ground surface on top of a 1.7 meters thick concrete foundation. This wall enclosed a water basin, and is 4.5 meters thick at the base and 1.65m thick at the top. Another 39.4 meter high brick wall with a thickness of 90 centimeters has been placed on the ground surface and around the former basin. Both walls overlap for 3.8 meters. This results in a total wall height of 48.2 meters.

The dome shaped roof structure spans the ends of the outer wall and extends 21.8 meters further into the sky. It existed out of an iron structure with a timber decking clad in zinc sheets. The iron structure is the only thing left of the original roof. The total height to the uppermost tip of the Gasometers is 70 meters.

Within the original wall structure of Gasometer C, a new structure is placed consisting out of concrete floors en walls. The public spaces direct on top of the former water basin are the biggest; having the largest spans and height. The collective offices on top have some smaller heights and spans. The dwellings in the top have the smallest measurements. These floors also have partition walls and voids evenly divided over the plan. They are placed in a multiple of 6.6 degrees turned around the centre of the building resulting in arched widths of the outer layer which are a multiple of 3.14 meters. This size is called X within the drawing of the grid structure.

PROGRAM

The Gasometers have developed a village character on their own and are thereby a city within a city. *"A true sense of community has developed, and both a large physical housing community (of tenants) as well as an active virtual internet community (Gasometer Community) have been formed."* (Gasometer Community, S.D.)

Each Gasometer is divided into several zones for living (apartments in the top), working (offices in the middle floors) and entertainment and shopping (shopping malls in the ground floors). Public parking is now situated within the former water basins.

The shopping mall levels in each Gasometer are connected to the others by sky bridges and underground passages. These extend 450 meters and include a concert hall, a cinema, more than 70 shops, restaurants, bars and cafes, a daycare center and The Vienna National Archive. This concept of mixed-use buildings creates a 24 hours occupancy and activity in the Gasometers with inhabitants working, living, and entertaining.

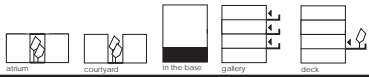

CYLINDRICAL BUILDINGS

In 1995 four architects won the competition for the redevelopment of the Gasometers. They each had a different interpretation for their Gasometer. Jean Nouvel has created a large indoor plaza with a translucent roof playing with reflections, refractions and transparencies of the old and the new. Coop Himmelb(l)au added a new 22 storeys building to the existing one. Manfred Wehdorn created an indoor garden and an eco-friendly designed terraced structure. Wilhelm Holzbauer occupied the centre of the existing building with lift and stairs, from which three compact sections were divided by indoor gardens penetrating the perimeter of the existing building.

As a result, a large-scale step-shaped courtyard in the form of an atrium is the center of the Gasometer C. It includes 92 apartments on the 6 top floors, 3 office floors in the middle, 2 shopping mall floors leading through all Gasometers on ground floor and a public parking garage of 5 floors in the basements. This results all together in a total amount of 7325 sqm living space, 5885 sqm of office space, 4450 sqm mall area, 1120 sqm warehouse space and 350 garage spaces.

FACADE + MATERIALS

This mix-used project reused the external facades of the four Gasometers as they are part of the city silhouette of Vienna. *"They are true monuments and landmarks in the cityscape. Therefore total demolition of the buildings was avoided and less demolition waste was generated. The restoration work showed that the external facades were in poor conditions. The top sections of the brick piers needed to be taken down and rebuilt. Reuse of the original material from the brick piers was not possible as the mortar which had been used was harder than the bricks and therefore impossible to be removed without dama-*

ging the bricks. Each Gasometer approximately needed one thousand replacement bricks." (Poon, S.D.)

The four Gasometers were created equal. Each gas container was enclosed by a red-brick facade. They had the same dimensions, windows and doors. They were as alike as quadruplets. Only through the revitalization and transformation of the interior by the four architects, each Gasometer got its own inner world and image. Gasometer A combines cool futuristic steel with glass. Gasometer B has a postmodern design. Gasometer C is realized in a modern version of the traditional Viennese Hofbauweise. Gasometer D has a green plant-rich vegetation. The Gasometers extend the wide range of different concepts.

Architecturally, Gasometer C impresses in several ways. The clear formal language can be interpreted as a modern version of the classic Viennese apartment house from the time of Adolf Loos combined with reinvented art nouveau elements. With the white fronts of the apartments sloped upward, the inner court opens up towards the sky. It is surrounded by pergolas, terraces and green and has the Vienna-typical impression from the 18th and 19th century and the Biedermeier-style.

Within the large total inner space, the great amount of greenery creates a place to socialize next to intimate areas and is of a high identification value. Architect Prof. Manfred Wehdorn designed the court to become a green oasis. He set the conditions in the planning stage. The walkways and spaces in the courtyard have flower beds and lawns. The trees in the center of the court revitalize the courtyard with greenery.

All four Gasometers are open towards the sky and received their silhouette by the old roof framing, exhibiting only "wind sliding sheet metals".

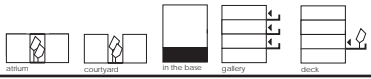

CYLINDRICAL BUILDINGS

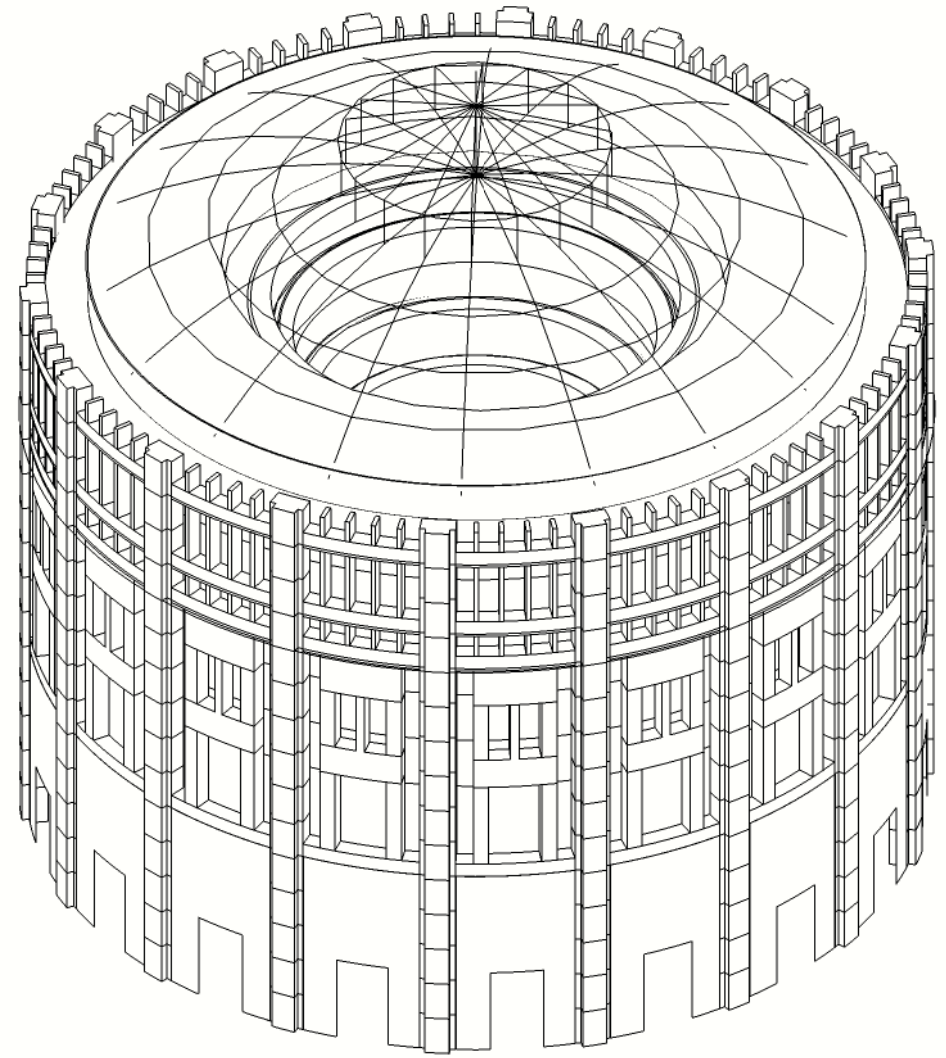
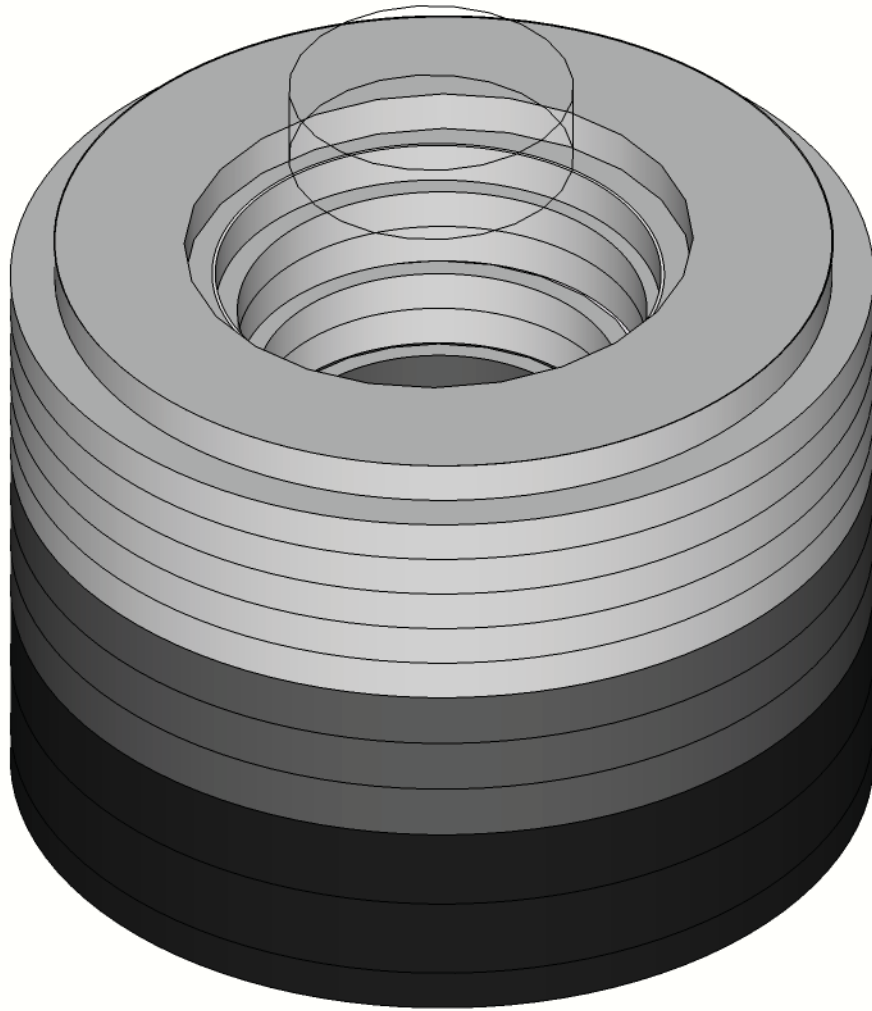

Program & Outside building scale 1:500 (own illustration)

CONTENT

public

collective

private

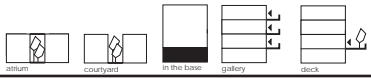

CYLINDRICAL BUILDINGS

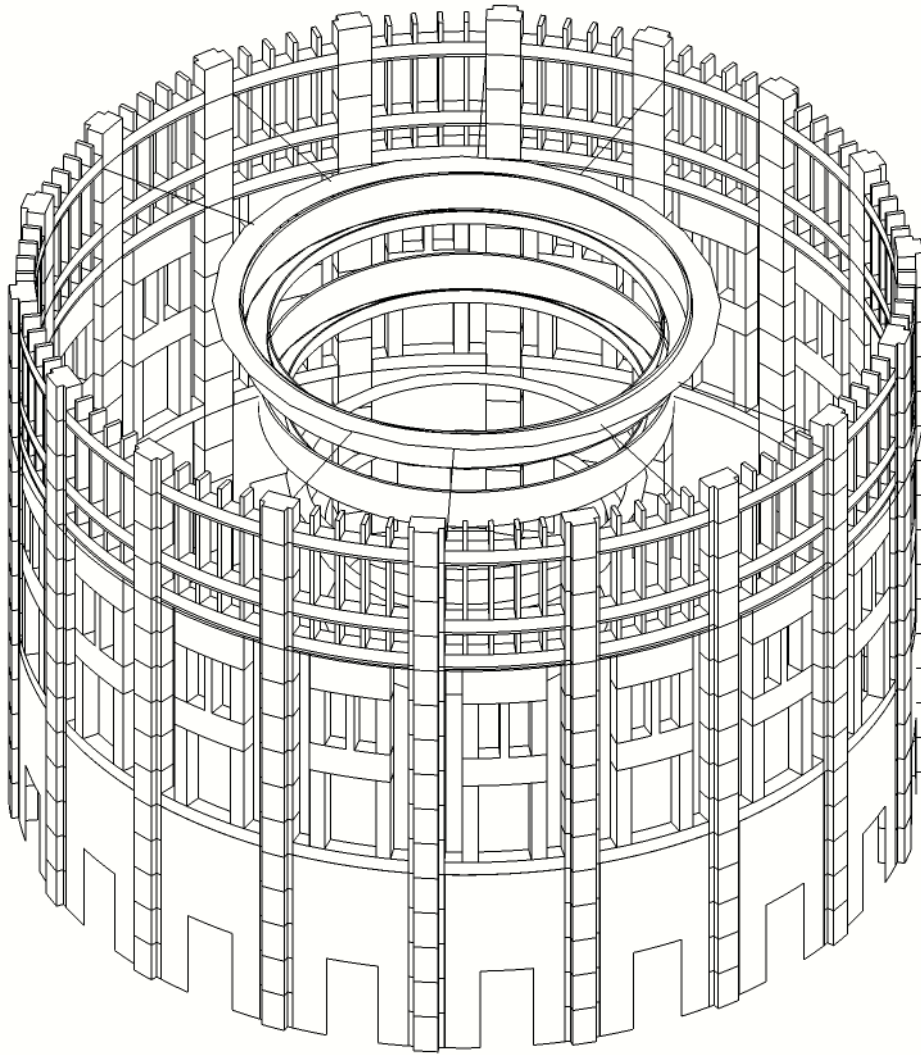

Inside building & Circulation scale 1:500 (own illustration)

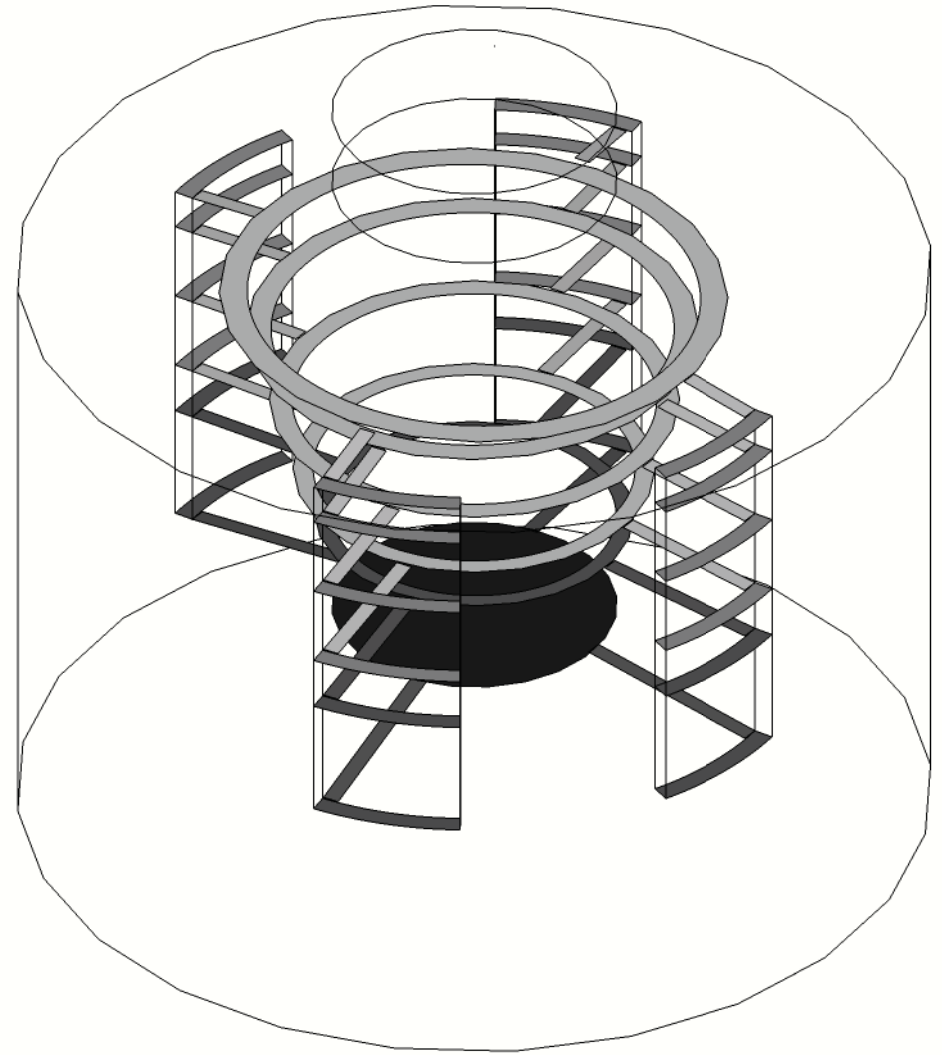

CONTENT

- public space
- circulation core dwellers
- circulation system office workers
- galleries dwellers

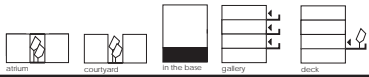

CYLINDRICAL BUILDINGS

CIRCULATION

The circulation within Gasometer C is to type as gallery. Although it is situated within the building envelope, it is situated outside the facade of the dwellings and offices and thereby is open to the air of the court.

The galleries are stacked on top of the dwelling or office units which results in different diameters. The width of the galleries also differs. The facade of some apartments is placed a little to the back to create small front gardens. As a result, some places on the galleries are also used as outdoor space of the dwellings. Thereby, the gallery can also be considered as a small sized deck. This is mainly the case on levels where only a small amount of apartments are accessed by one gallery. This, and the fact that on some levels there is no gallery at all, is made possible because of the presence of multi-storey apartments or maisonettes.

Due to the various amount of users on the different galleries, the dwellings connected to these galleries have different levels of privacy.

The galleries are all connected by four circulation cores. All of these give access to the shopping mall and parking garage and also to the outside of the building.

From the collective galleries there is a visual relation to the even more collective inner garden and shopping mall. This visual relation is not of any influence on the private domain of the dweller, but does enliven the building for both the dweller and the visitor. There is no relation what so ever with the world outside of the Gasometer; resulting in the feeling of being in an own world within the city of Vienna.

DWELLING TYPES

The Gasometers house hotels, as well as about 70 student apartments with 250 students in residence. There are also about 800 apartments (two thirds within the historic brick walls) with 1600 regular tenants. 92 of these dwellings are situated within Gasometer C. These dwellings have been built in a ring shape along the inside of the outer wall. The dwellers can enjoy an extensive view of Vienna through the windows on the outside wall. The circular shape is divided into segments by means of incisions. These serve as staircases or as additions to the courtyard. By the stair-like arrangement of the floors of the dwellings and offices, the courtyard is very bright. Some of the apartments have loggia- or balcony-like terraces facing the courtyard and/or facing the outdoor location.

Gasometer C shows a modern version of the traditional Viennese design. Manfred Wehdorn managed, thanks to the typical Viennese arcades – known as Viennese “Pawlatschen” – to make the courtyard a lively place. The arcades are the entrances to the apartments and are situated within the terraced courtyard. They create within this large courtyard intimate areas and add the identity to the place. The floor plan design and the used materials (white plaster, wood, brushed stainless steel) are of compelling simplicity. Design and implementation reflect the belief of the architects: *“The poetry of simplicity that will outlast me in her clear, caused by the functional design language and pass the time.”* (Wiener Gasometer, S.D.)

Gasometer C includes a big variety of different apartment types, there are over 10 different types, which differ from single room, to two, three and four room apartments. These apartments can incorporate one, two or even three floors. One single room apartment, one 3 room apartment, one 4 room apartment and one 2 room maisonette over 3 floors will be analysed more deeply.

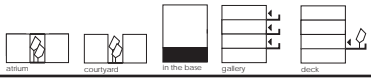

CYLINDRICAL BUILDINGS

Situation

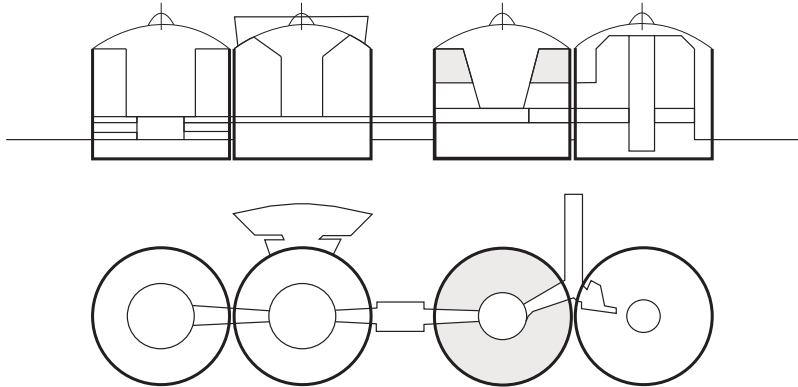

Section

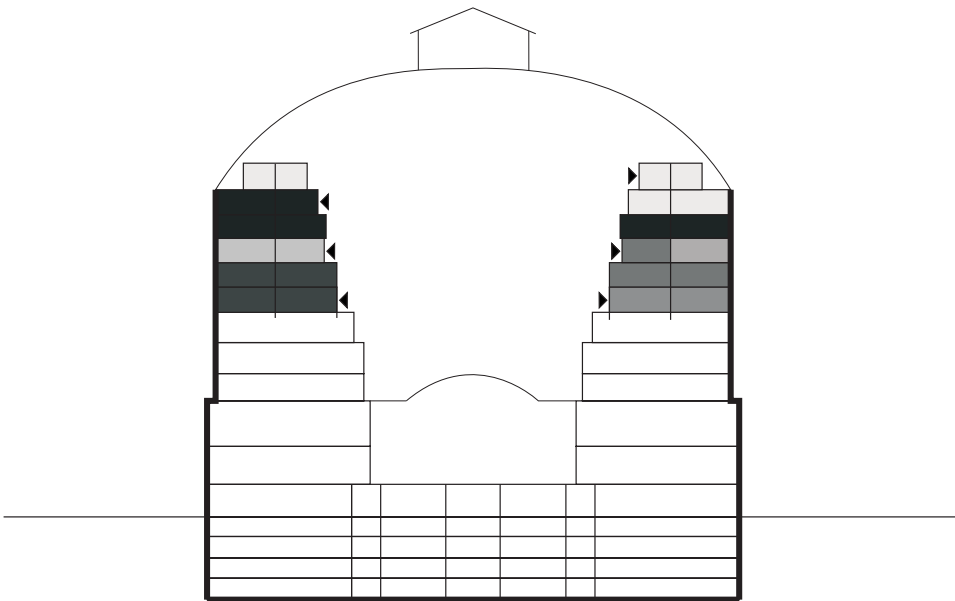

Dwelling typologies (own illustration)

Eighth floor

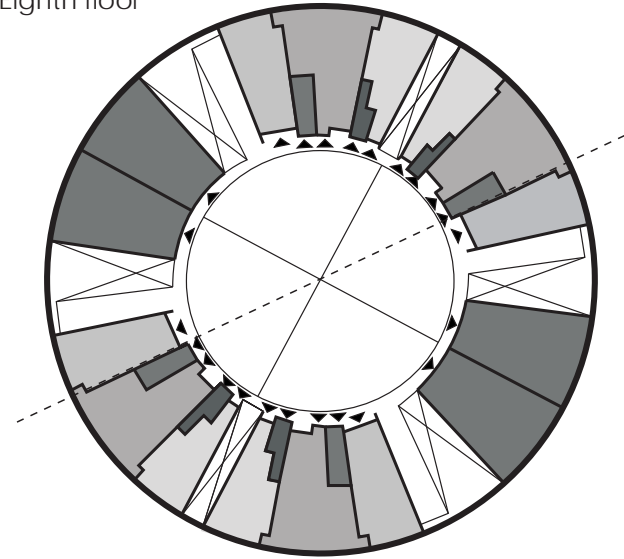

Sixth floor

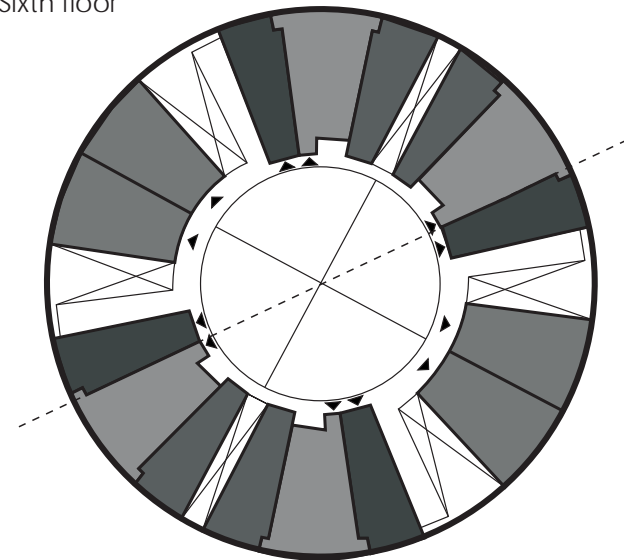

CONTENT

- 1 room apartment
- 2 room apartment
- 3 room apartment

- 4 room apartment
- loft
- 4 room apartment over 2 floors

- 2 room maisonette over 3 floors
- maisonette 2 floors
- maisonette 2 floors & roof garden 1 4 6

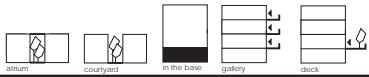

CYLINDRICAL BUILDINGS

SINGLE ROOM APARTMENT

The single room apartment consists out of one big and open single room with a division wall to insinuate the room can be split in two. It cannot be considered a loft because it has a separate hallway and the service blocks; as a kitchen en wet rooms, are positioned to the sides of the apartment.

The apartment has no outside space, but a France balcony which has a lookout at city of Vienna. It has access by a gallery. Dwellers can rent a separate office space on one of the lower levels of the building. The most important function of this unit is living, and that is the reason why this dwelling can be seen as a 'live-work nearby' unit.

THREE ROOM APARTMENT

The three room apartment consists out of one big hallway and three rooms separated by walls. On the edges of the rooms, the service blocks – as the kitchen and the wet rooms - are placed. This apartment also has a France balcony which has a lookout at city of Vienna. At the same time the facade on the courtyard side is partly placed to the back. This leaves a place which can be appropriated by the dweller as a private outside space. Thereby the apartment has access by a deck.

One of the rooms has is directly adjacent to the recess of the deck. Thereby it has its own entrance. Therefore the room can be used separately from the rest of the house, as an office for instance. The most important function of this unit is living, and that is the reason why this dwelling can be seen as a 'live-work near' unit.

FOUR ROOM APARTMENT

The four room apartment consists out of one big living and three

additional rooms separated by walls. The service blocks – as the kitchen and the wet rooms – are placed on the edges of the rooms. The apartment has a loggia which has a lookout at city of Vienna. At the same time the facade on the courtyard side is partly placed to the back. This leaves a place which can be appropriated by the dweller as a private outside space. Thereby the apartment has access by a deck.

One of the rooms can be used as an office. The most important function of this unit is living, and that is the reason why this dwelling can be seen as a 'home occupation' unit.

TWO ROOM MAISONETTE OVER THREE FLOORS

This two room maisonette contains three different functions on three different storeys. The entrance of this dwelling is on the highest level. The middle floor consists out of one big open space for living. The bottom level consists out of one big open space for more private activities. The lower you get in the dweller, the more private it gets. Division walls insinuate that the rooms can be split in two. The service blocks; as a kitchen en wet rooms, are positioned to the sides of the apartment.

The apartment has no outside space, but two France balconies which have lookouts at city of Vienna. It has access by a gallery. The mid-level of the dwelling is not adjacent to a gallery, whereas the bottom level is adjacent to a gallery. This gallery adjacent to the bottom level is only used by two other dwellers, which do not have to pass this dwelling. Also the wet rooms are positioned to the wall separating the gallery from the private indoor space. Therefore the privacy is not at stake.

One of the rooms can be used as an office. The most important function of this unit is living, and that is the reason why this dwelling can be seen as a 'home occupation' unit.

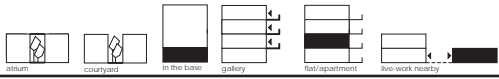

CYLINDRICAL BUILDINGS

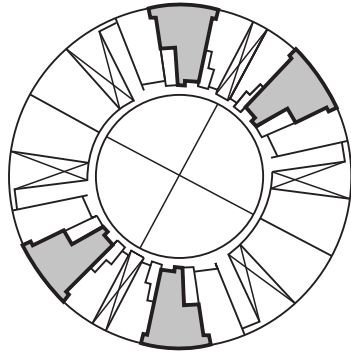

Eighth floor

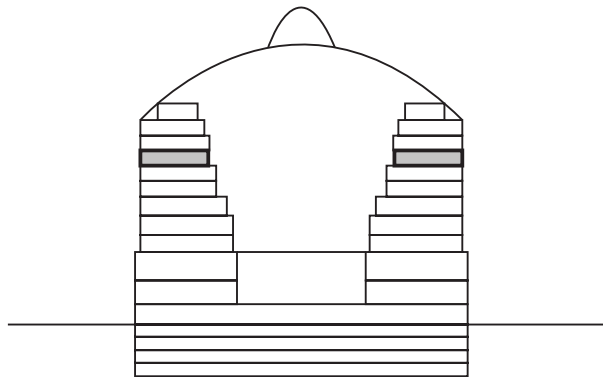
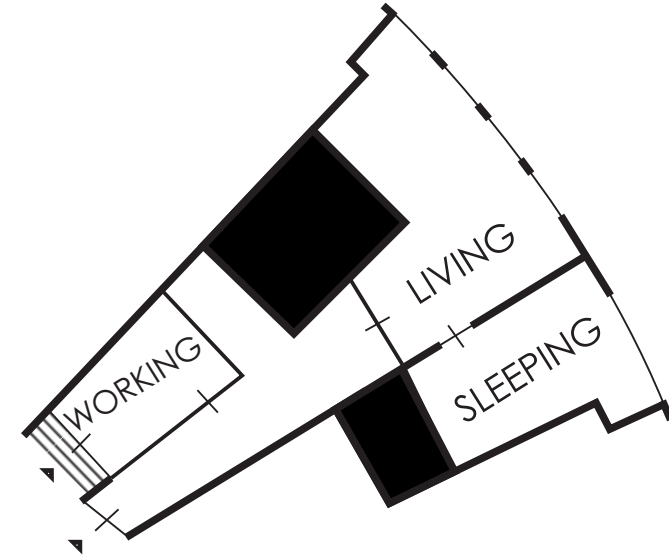

Section

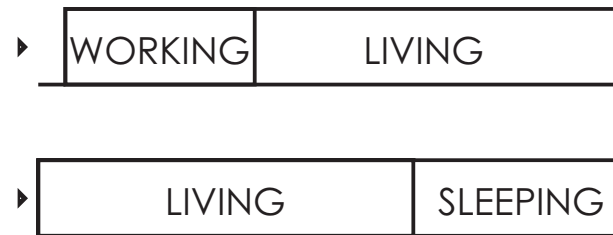

Apartment type 1 floorplans and sections scale 1:1000 & 1:150 (own illustration)

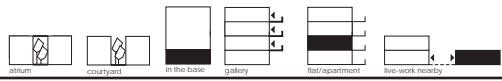

CYLINDRICAL BUILDINGS

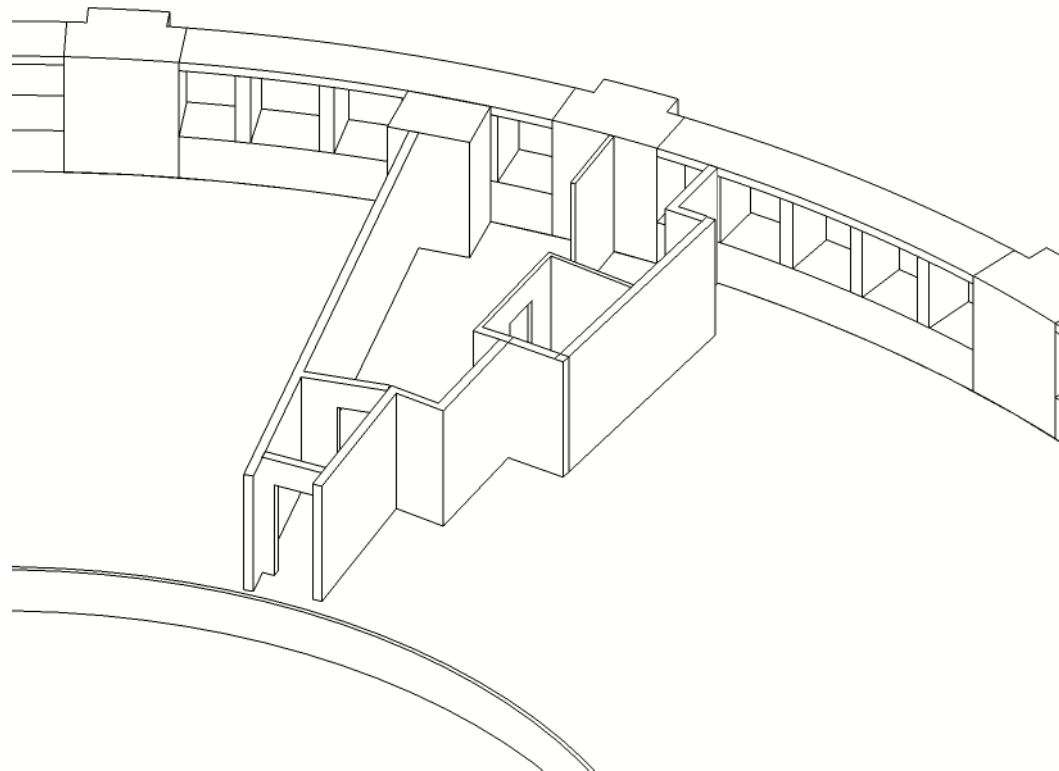

Apartment type 1 axonometry scale 1:150 (own illustration)

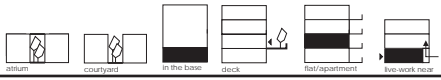

CYLINDRICAL BUILDINGS

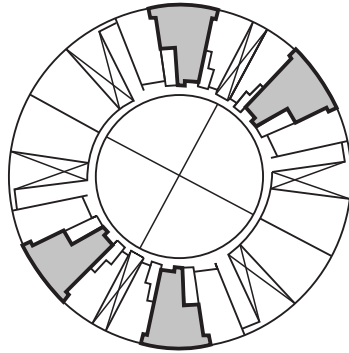

Eighth floor

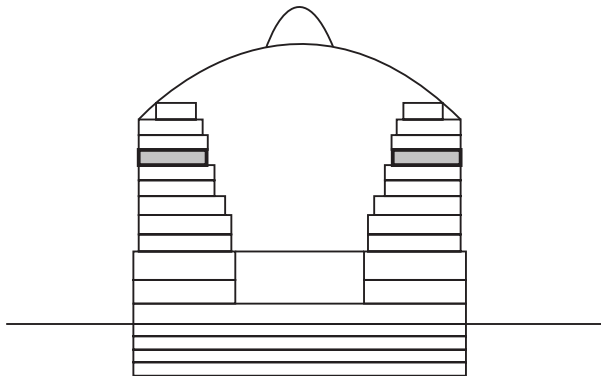

Section

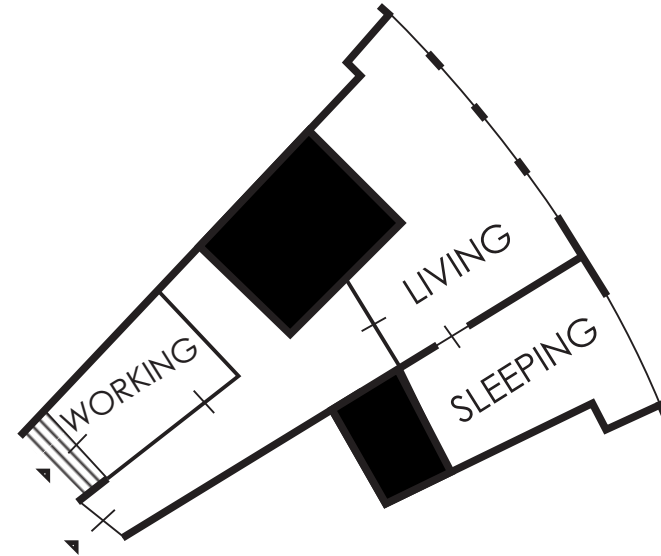

Apartment type 2 floorplans and sections scale 1:1000 & 1:150 (own illustration)

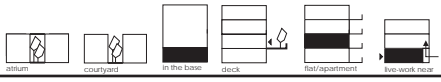

CYLINDRICAL BUILDINGS

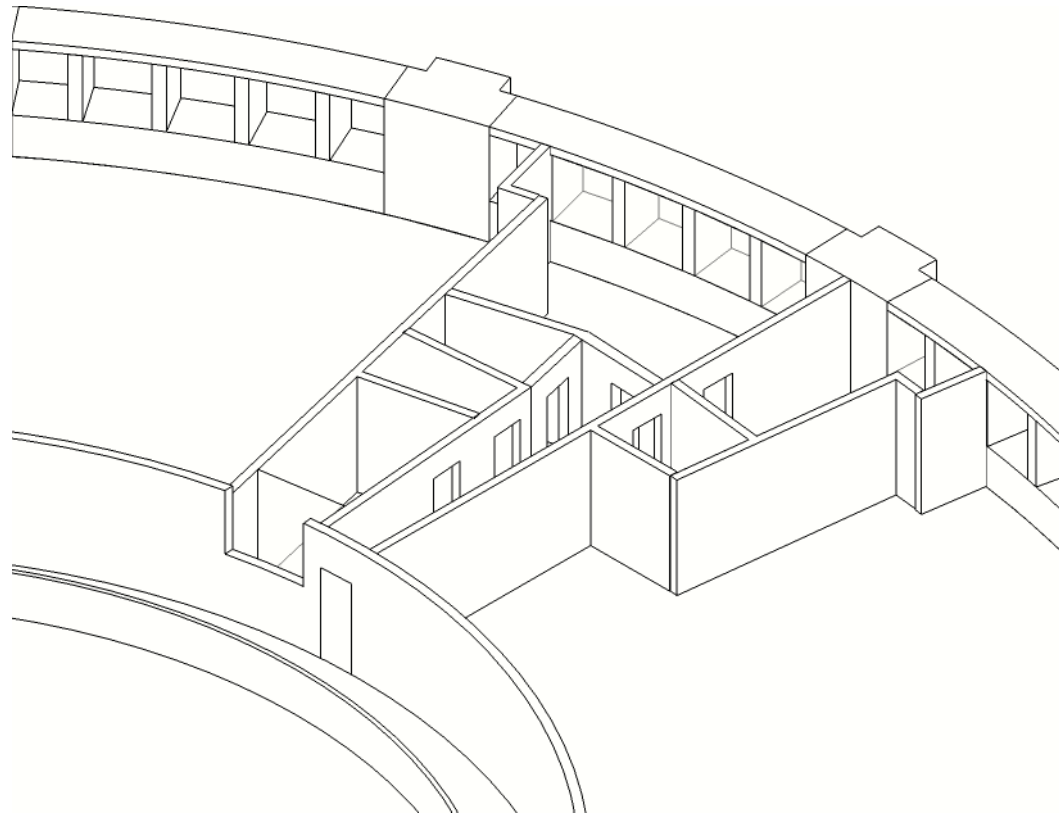

Apartment type 2 axonometry scale 1:150 (own illustration)



CYLINDRICAL BUILDINGS

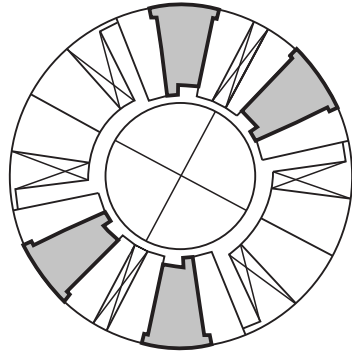

Sixth floor

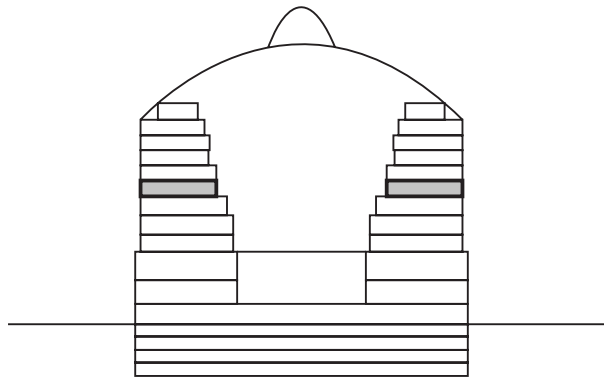

Section

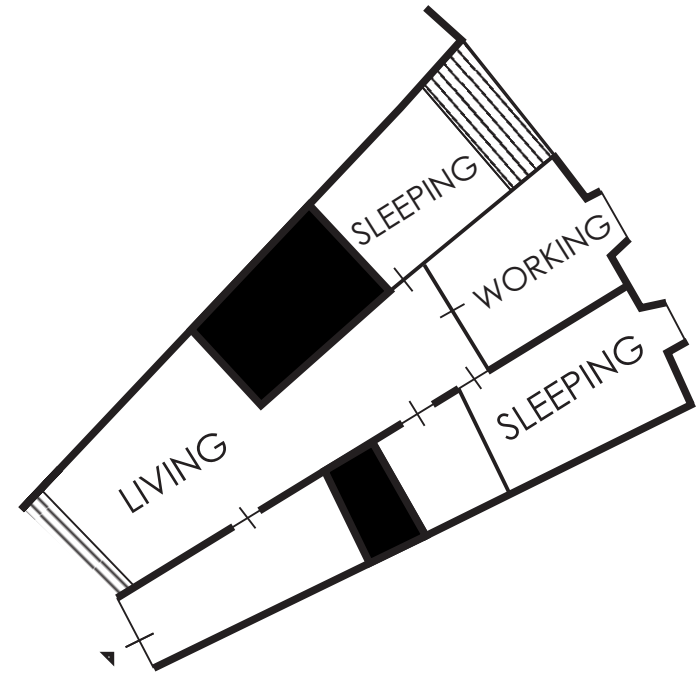

Apartment type 3 floorplans and sections scale 1:1000 & 1:150 (own illustration)



CYLINDRICAL BUILDINGS

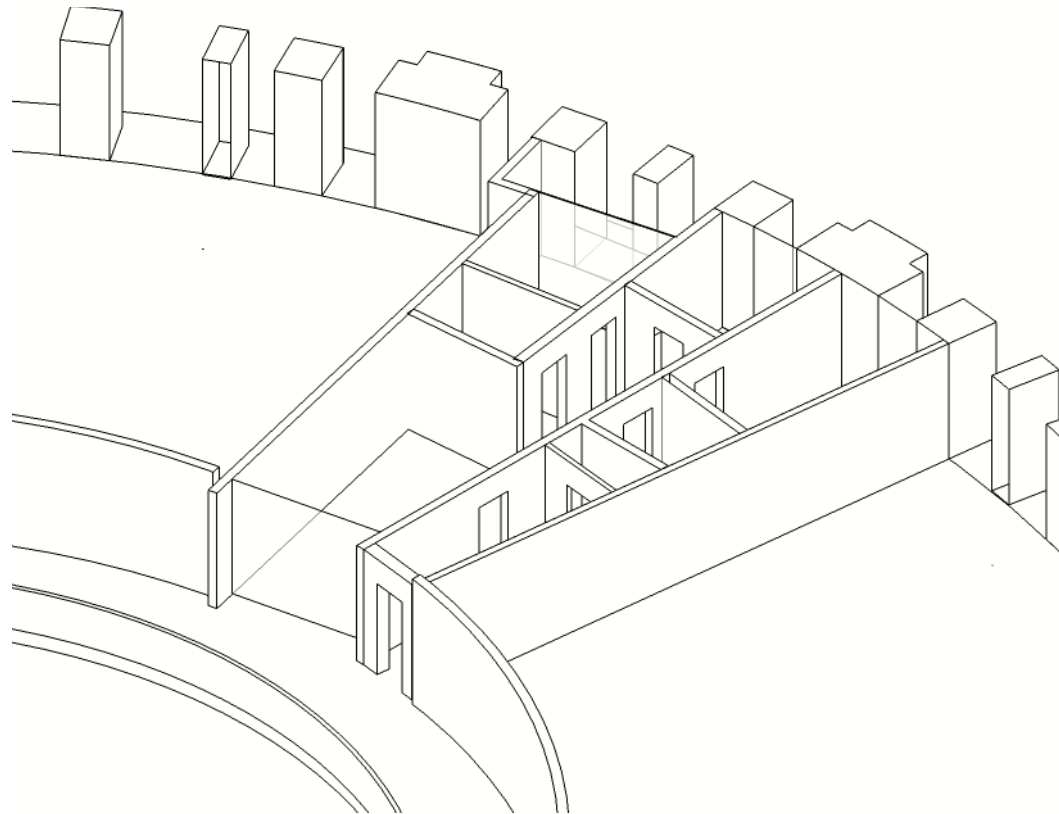

Apartment type 3 axonometry scale 1:150 (own illustration)

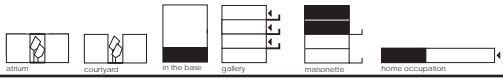

CYLINDRICAL BUILDINGS

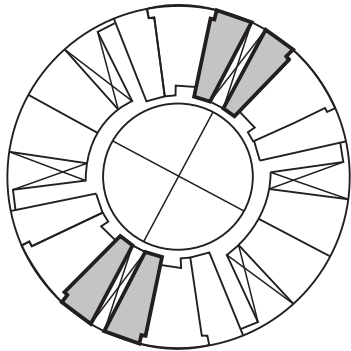

Sixth floor

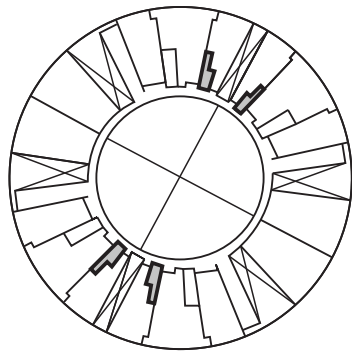

Eighth floor

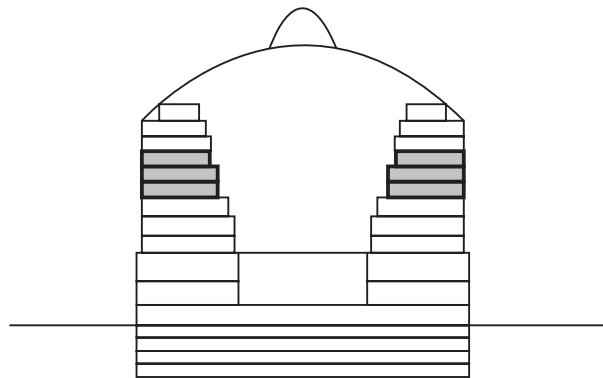
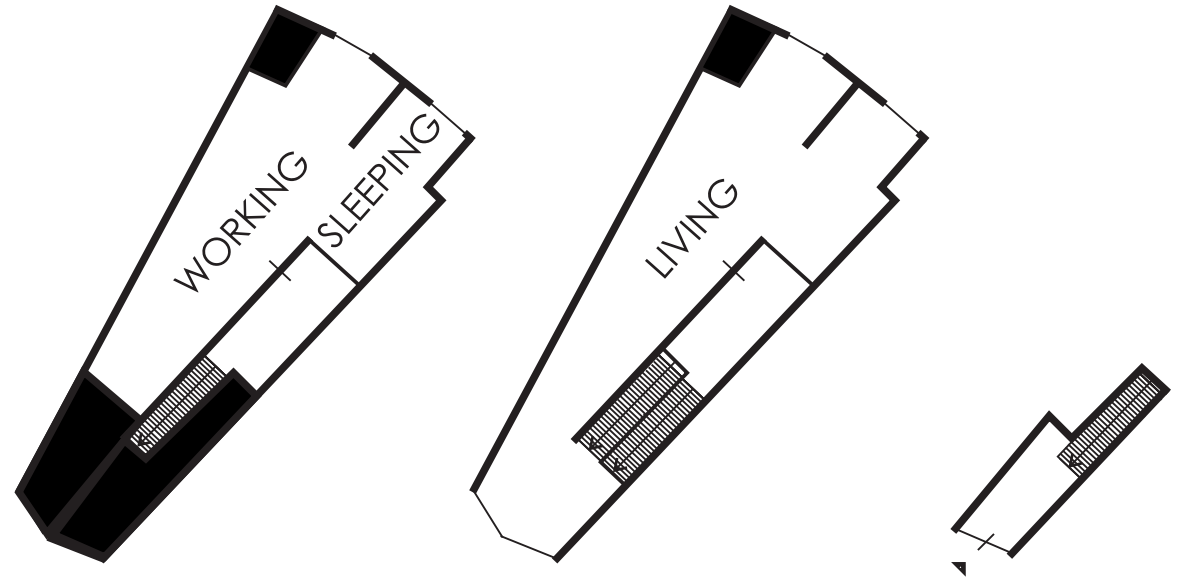

Section

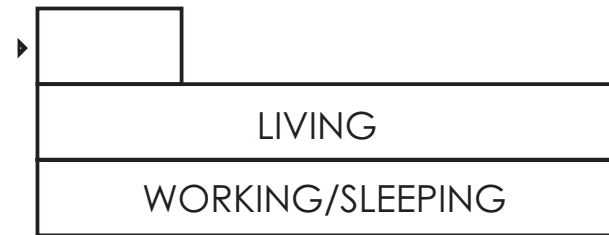

Maisonette type 1 floorplans and sections scale 1:1000 & 1:150 (own illustration)

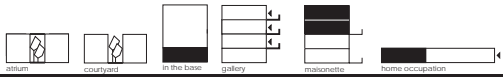

CYLINDRICAL BUILDINGS

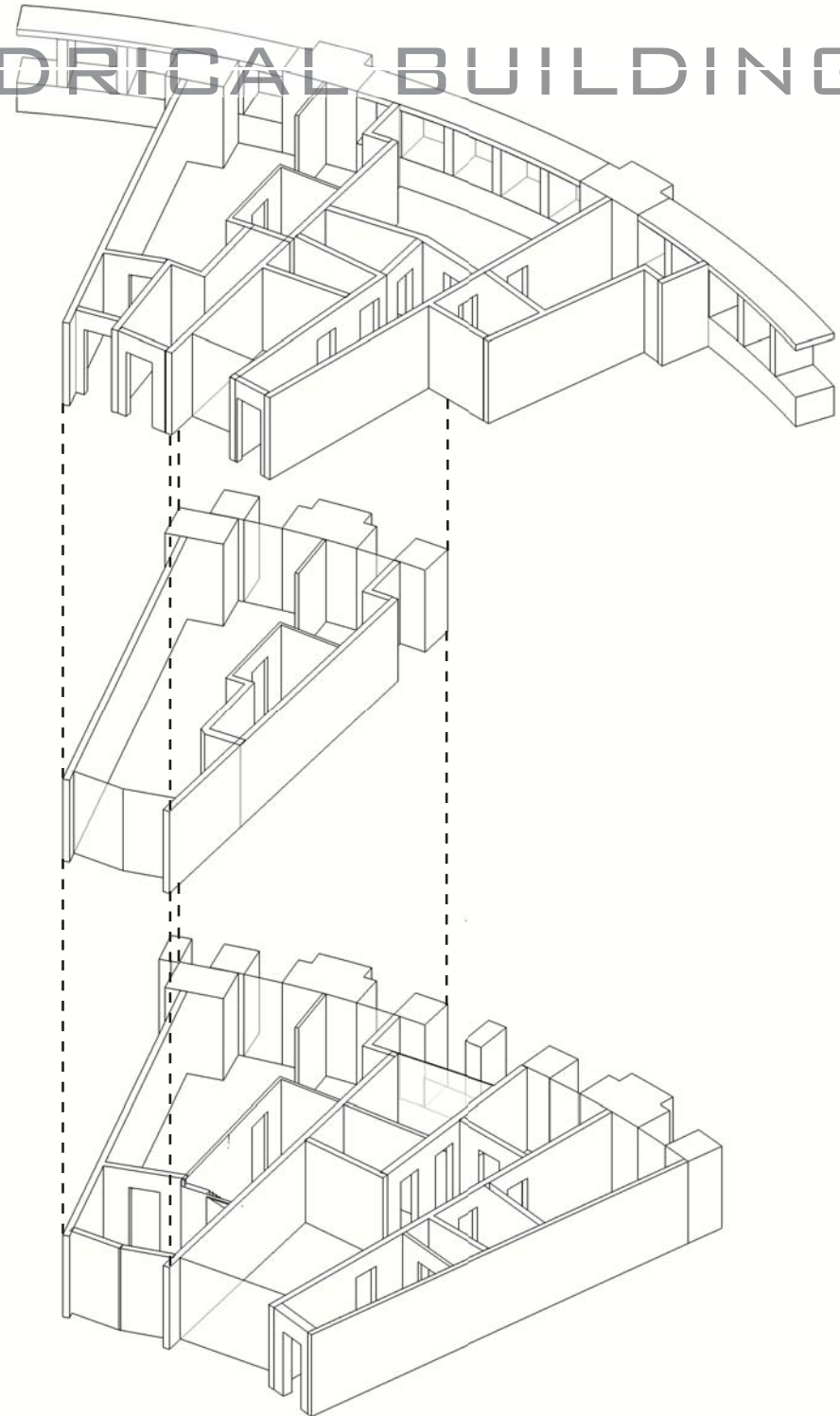
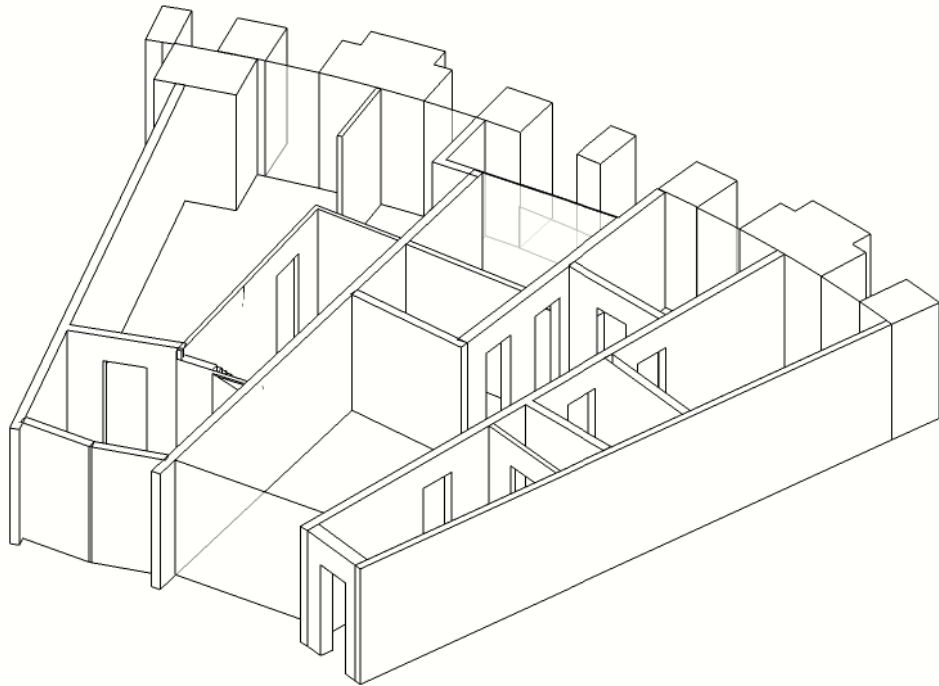

Maisonette type 1 axonometry fragment scale 1:150, whole dwelling scale 1:200 (own illustration)

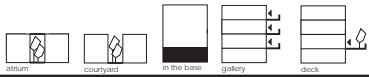

CYLINDRICAL BUILDINGS



DAYLIGHT

The dwellings within this building have daylight penetration from two sides. Although the deepest apartments are up to 14 meters deep, this two sided orientation provides the dwellings enough daylight to feel comfortable. How higher the apartment is situated within the building, the better the daylight conditions get. Even though the lowest apartments do not meet the requirements, people still like to live here.

INTERIOR

The height of the dwellings, less than 2.8 meters cannot be the reason for wanting to live there. Also the interior does not show a lot of details of the former function of the building. Even the outer facade is not a recognizable feature from the inside of the dwellings as we can see from the interior view.



OUTSIDE SPACE

Dwellers also don't have a lot of outside space. Some dwellings have a roof garden or a loggia. Others have to be satisfied with just one or two France balconies. Galleries or decks functions also as a kind of outside space, but they have a more collective character. These galleries are placed around an even more collective courtyard. The galleries or decks and this courtyard do give identity to the building and, because all buildings are accessed by these, also to the dwellings. The green, the stepped built-up, but especially the steel structure of the former roof add also more identity to the building.

That there is a lack of private outside space enlarges the collective engagement. The stepped built-up of the dwelling, the recesses in the deck, the small amount of people passing one gallery and the large amount of green at the same time gives the dwellers the feeling of being more private.

Outside space (Wiener Gasometer C, S.D.)

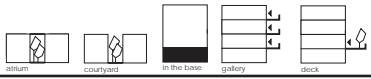

CYLINDRICAL BUILDINGS

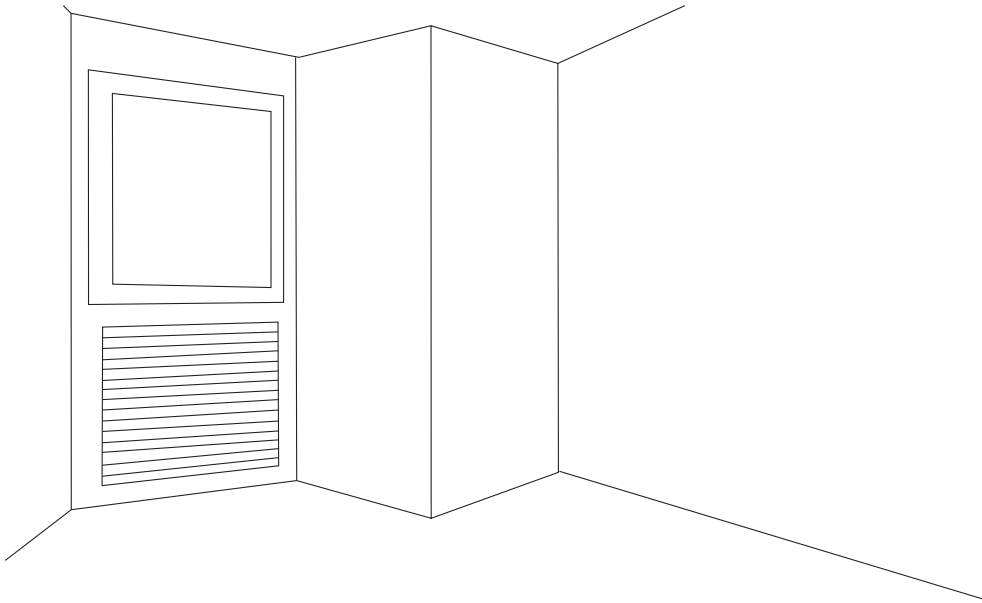

Interior dwelling (own illustration), (9Flats.com, S.D.)

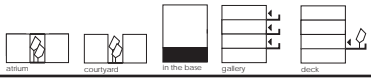

CYLINDRICAL BUILDINGS

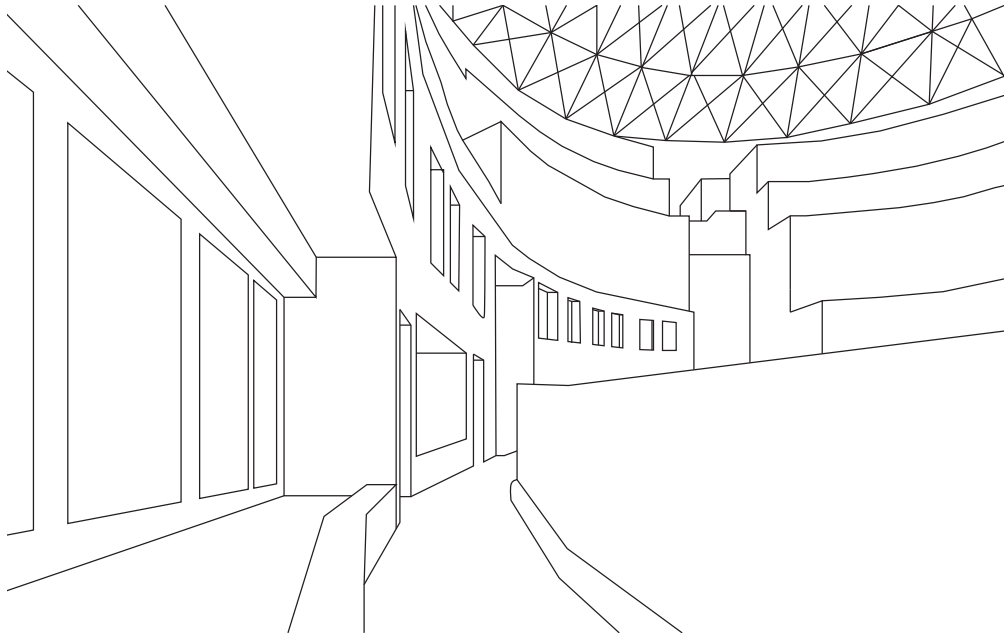

Outside space (own illustration), (Wiener Gasometer C, S.D.)

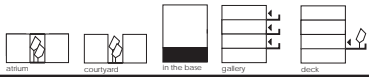

CYLINDRICAL BUILDINGS

CONCLUSION

Cylindrical Buildings which are most popular for conversion are the watertowers. Watertowers are by their scale easy to manage, because for their characteristic facades are no large interventions needed. Thereby watertowers are useful for multiple different functions.

The smallest watertowers with a diameter around 10 meters are mostly re-used as private dwellings or offices. The realized loft type dwellings have access on ground level. Adaptation of the facade is in these cases necessary.

The bigger watertowers with a diameter around 25 meters are mainly occupied by the creative sector. They realized a whole arsenal of different functionalities within them. When residential functions are combined with other functions; the public functions are situated in the base of the tower. The loft type dwellings are accessed by a corridor.

Within these types of buildings working and living are easily combined. The quality or presence of an outside space is less likely. What we can learn from these buildings is that people like to live in characteristic buildings. In form and scale, these buildings do not necessarily add to the existing housing stock, although it can lead to an interesting variety.

Silos are in scale similar to the bigger watertowers. However, their facade misses the same characteristics. Thereby, silos converted to apartment buildings are often plain apartment towers; like the Carlsberg apartment tower in Copenhagen. Additional functions are situated in the base, access to the apartment type dwellings is through a corridor and the outside space has the form of a balcony. After conversion, there is little left of the characteristics of the silos; the solid, concrete shell and the emptiness inside.

However, when the facade of a silo is not very interesting to show and for residential re-use unsuitable, hanging apartments on the outside of the building give the opportunity to maintain the characteristic inside emptiness of the building. Thereby additional functions are again placed in the base. Access to the apartment type dwelling with a balcony is through a gallery within an atrium. We have already seen this situation of a gallery within the building envelope in the warehouse chapter. Thereby the gallery gets the definition of a corridor with a lot more spacious experience. Conversions in such a way, lead to nice circulation spaces and qualitatively high apartments. Although, from the original building does not seem to be left a lot. In one way this approach conserves the industrial heritage. The other way round, for its new appearance it could have been totally new built as well. Now, in the new built residential stock we do not see very often these kind of building forms, which especially in new built apartment towers seems to be a missed chance.

Here, the circular shape is more than just an interesting variation for the already existing building stock. Although, the envelope of the building shows big similarities with other atrium type buildings, the circular shape has a high additional value for the circular circulation space inside the building. For, by a minimal amount of building material, the maximal amount of space is to realize; which leads to even more important: maximum distance between dwellings and thus a maximum amount of privacy.

Brick Gasometers have bigger floor surfaces than the other cylindrical buildings. The height and diameter are around 50 meters. In combination with a characteristic facade, it is possible to position dwellings inside, without affecting the characteristic exterior or empty interior. By positioning the dwellings along the facade an

CYLINDRICAL BUILDINGS

Small watertower

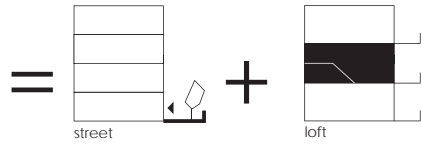

Bigger watertower

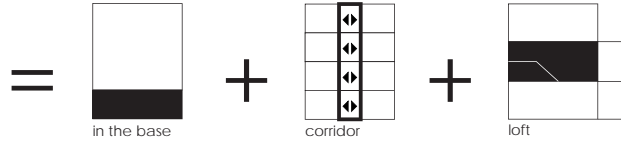

Silo with dwellings inside

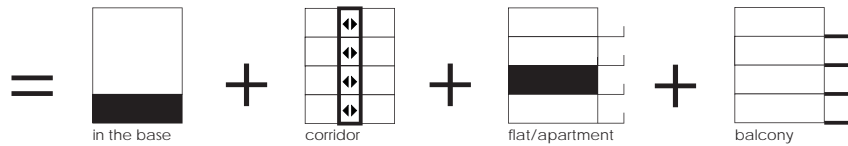

Silo with dwellings outside

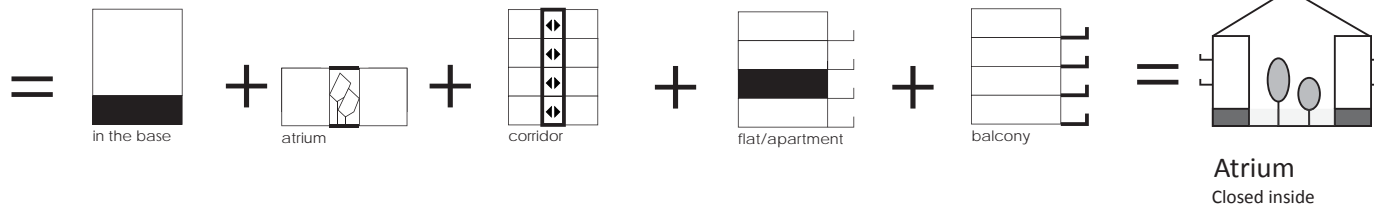

Gasometer

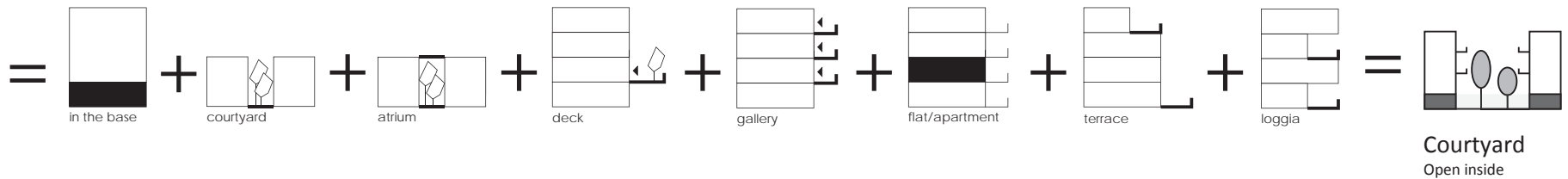

Conclusion cylindrical buildings (own illustration)

CYLINDRICAL BUILDINGS

empty centre remains.

Additional functions are easily placed within the former basin in the base. To provide these spaces with daylight, an atrium can be an outcome. Access to the apartment type dwellings is by a gallery around a courtyard. In between the gallery and apartment, space could be reserved for outside spaces as loggias or terraces; resulting in the gallery becoming a deck.

This rich range of possibilities makes brick Gasometers an interesting building envelope. Although the envelope shows big similarities with other courtyard type buildings, the circular shape has high additional value for the circular space inside the building. By the form, a maximum amount of privacy is to be realized, which is great on the level of circulation. Another side effect is the maximum experience of enclosure. This has additional value for the courtyard inside and the community of the building.

Apartments realized in new built cylindrical buildings often lead to high, slim apartment towers. These are landmarks, but lack real character, good usable outside spaces, and a sense of community. As atrium or courtyard type buildings cylindrical buildings do have great potentials not only for re-use, but also for the new to build building stock. These buildings have the possibility to enrich the existing building stock. The cylindrical form enlarges the privacy within atrium and courtyard type buildings for its dwellers. At the same time it enlarges the sense of community. This sounds contradictory, but this has all to do with the difference in experience in the centre of a cylindrical building; which feels maximal enclosed, and the surrounding dwellings; which have maximum distance to their neighbours on the other side and are not able to look directly at their neighbours next door.

Important for these types of buildings is their scale. A good cylindrical atrium or courtyard building should be up to 50 meters high and should have around the same diameter. For atrium buildings, the diameter could be somewhat smaller and the height somewhat higher to establish a pleasant atrium. For a courtyard building, the diameter could be somewhat bigger and the height somewhat smaller to establish a pleasant courtyard. This is due to the fact that the apartments within the atrium type buildings are more related to the outside, as their outside spaces are. The courtyard type buildings are more related to the interior, as their outside spaces are and the collective outside space is.

CYLINDRICAL BUILDINGS

FOOTNOTES

1. LINTSEN, H. W. 1992. *Geschiedenis van de techniek in Nederland. De wording van een moderne samenleving 1800-1890. Deel I: Techniek en modernisering. Landbouw en voeding*, Zutphen, Walburg Pers, (pp. 253-277).
2. TER BORCH, I. 2001. Herbestemming van Graansilo's blijkt succesformule. *Renovatie & Onderhoud*, 30-33, (p. 31).
3. LINTSEN, H. W. 1992. *Geschiedenis van de techniek in Nederland. De wording van een moderne samenleving 1800-1890. Deel I: Techniek en modernisering. Landbouw en voeding*, Zutphen, Walburg Pers, (p. 243).
4. Ibidem (p. 243).
5. LINTSEN, H. W. 1993. *Geschiedenis van de techniek in Nederland. De wording van een moderne samenleving 1800-1890. Deel II: Gezond en openbare hygiëne. Waterstaat en infrastructuur. Papier, druk en communicatie*, Zutphen, Walburg Pers (pp. 76-77).
6. LINTSEN, H. W. 1993. *Geschiedenis van de techniek in Nederland. De wording van een moderne samenleving 1800-1890. Deel III: Textiel. Gas, licht en elektriciteit. Bouw*, Zutphen, Walburg Pers, (pp. 106-133).
7. VAN HULTEN, A. 1985. *Werkstad: 30 industriële monumenten in Rotterdam*, Rotterdam, Stichting industrieel erfgoed Rijnmond.
8. SOETERS VAN ELDONK ARCHITECTEN. S.D. *Halfweg - Herontwikkeling suikersilo's 2002>2009* [Online]. Available: www.soetersvaneldonk.nl [Accessed 04-01-2013].
9. MVRDV. S.D. *Gemini residences - Frøsilø* [Online]. Available: www.mvrdv.nl [Accessed 04-01-2013].
10. MØLLER, C. P. S.D. *Siloetten* [Online]. Available: www.cfmoller.com [Accessed 05-01-2013].
11. TIVOLIS VENNEN. S.D. *Tivolis højhusprojekt* [Online]. Available: www.tivolisvenner.dk [Accessed 05-01-2013].
12. GASOMETER OBERHAUSEN. 2013. *Technology* [Online]. Available: www.gasometer.de [Accessed 05-01-2013].
13. NEDERLANDSE WATERTOREN STICHTING. 2002-2011. *Herbestemming* [Online]. Available: www.watertorens.nl [Accessed 05-01-2013].
14. VAN HULTEN, A. 1985. *Werkstad: 30 industriële monumenten in Rotterdam*, Rotterdam, Stichting industrieel erfgoed Rijnmond.
15. STEENHUIS, M. & MEURS, P. 2011. *Herbestemming in Nederland. Nieuw gebruik van stad en land*, Rotterdam, NAI Uitgevers, (pp. 66-71).
16. WATERTOREN IJMUIDEN. S.D. *Appartementen - Loft aan de Watertorenpad in IJmuiden* [Online]. Available: www.watertorenijmuiden.nl [Accessed 05-01-2013].
17. ZECC ARCHITECTEN S.D. *Woonwatertoren Soest*. Utrecht: Zecc Architecten, (pp. 1-3).
18. WIENER GASOMETER. S.D. *1985 Die Gasometer gehen in Ruhestand* [Online]. Available: www.wiener-gasometer.at/de [Accessed 02-01-2013].
19. WIENER GASOMETER. S.D. *Die Mauer der Gasometer* [Online]. Available: www.wiener-gasometer.at/de [Accessed 02-01-2013].



Scheepvaarthuis (Wikipedia, S.D.)

HISTORY

The first office buildings that were built, which show a comparison with the buildings these days, were built in the late nineteenth century. Before that time only smaller offices, that look like normal houses or offices in the factories were built for high educated people. This all changed when big service companies, like bank and insurance companies, asked for bigger offices. These enterprises have a large administration department and therefore the need for bigger office spaces.¹

Throughout the years, and in particular around the first decades of the twentieth century, there are built many office buildings in the Netherlands.² The reason therefore where the companies themselves. Most of the buildings were built in commission by the company and therefore built in architectural respect. Because the buildings were the companies visit card those days. A typical office building is the former **Scheepvaarthuis** at the Prins Hendrikkade in Amsterdam. This Building is built in 1916 commissioned by The Royal Dutch Steamboat Company. This building is designed by architect Van Der Mey, de Klerk and Kramer and looks like a ship which is moored with the bow facing towards the Central Station. Most of these buildings became icons for the cities.³

Because of the introduction of the law on workability (Arbo-wet) in 1979, the minimum space of one person increased and was set at 24m². Also the rules on daylight and opening windows for fresh air changed. All of these ask for a new design of office building in the late seventies. Nowadays the stock on office buildings is increased with approximately 70% and has a total amount of 46.5 million m². For years investors believed there was no limit to the demand of office buildings. Now there is a big problem on the vacancy of these buildings.⁴



Magna Plaza (Kalk, 2010, p. 89)



ING House (Awais, 2007)

CHARACTERISTICS

Office buildings as known these days are big buildings often without character. However there is a significant difference between buildings made after the late twentieth century and buildings before that. The in 1899 build Dutch post office at the Nieuwezijds Voorburgwal (now known as **Magna Plaza**) in Amsterdam and designed by government architect C.H. Peters, is a good example of an office building built and designed with character. The building is a mix of neogothic and neorenaissance style with big dormers, pointed facades and brick stoned towers on the outside of the building. Arches and a glass dome dominate the interior of the building. The high ceilings also play their part in the characteristics of office buildings like these. Most of the office buildings built these days have not much character but made for functionality. Four big facades with a lot of windows. Construction consists out of beams and spams. The interior is made of Metal Stud walls which are easily tear down to make more or a different space.⁵

The last decades architects have succeeded to make a mix between design and functionality. An example of a building like this is the **ING House** in Amsterdam designed by architects Meyer en Van Schooten.

ADAPTATION

Most of the office buildings of the late twentieth century are built on collection sites outside the city centre and separated from dwellings, like Teleport in Amsterdam. On this location there is a natural border between dwelling and the offices. Because locations like these are deserted after closing hours and therefor unattractive to live. Above all the character of the buildings makes it very expensive to redesign. Everything has to be stripped in order to make it a liveable place. Office buildings built in the late twentieth century,

are often built in the centre of the city and have a lot of character.⁶ That makes them easier to adapt for a dwelling program, because of the privileges that it has like a location in the city centre and because of the public transport nearby.

An example of an adapted complex are the **Churchilltowers** at the Churchilllaan in Rijswijk; two identical towers built originally in 1970 at the edge of the industrial area Plaspoelpolder. The towers are situated near a residential area, highway, public transport and shopping mall. The towers are designed by Lucas and Niemeijer architects and characterized by their rough materials of concrete and glass. The buildings are adapted in 1999 designed by Oving Architects to 116 apartments and 4 penthouses on 11 floors for each tower. The average living space is 167m² with the apartments and 172 m² for the penthouses. Each level has 6 apartments and is characterized by high ceilings of 3.10 meter. Because the lack of privacy the ground floor level is sold as commercial space.⁷

This is different in an office building in Emmeloord now called "**Residential De Deel**". This building is designed by architect S.J. van Emden and is a former office for the water authority. It had an business like appearance, light and industrial. The building is oriented around a main lobby. The building is transformed into a building with 18 apartments with an underground garage designed by G.Stuve, Ir. C.P. v.d. Bliëk. The apartments can be entered from the Atrium (main lobby) with inside garden. Because of the bad maintained façade, a totally new façade is built instead, now with balconies and loggias. The architect has attempted to close the walls on the columns, but didn't give a good floor plan. Therefore they decided to leave the grid and leave the columns in open space. After that the columns where a good element in the space of the apartment



Churchilltowers (Oudijk, Remøy, Van der Voordt, 2007, p. 147)

and an advantage for selling. The architect chose for one floor plan on all floors.⁸

Another project with more floor plans is a project called De Grote Enk in Arnhem. This building is the former headquarters of the company AKZO Nobel and designed mid-fifties of the twentieth century by H.T.Zwiers, at that time a professor at the TU University Delft. This building was adapted in 2006 and designed by the Bureau for Harmonic Architecture (Bureau voor Harmonische Architectuur). The offices made place for 69 apartments.



Residential De Deel (Oudijk, Remøy, Van der Voordt, 2007, p. 129)

OFFICES

DE GROTE ENK



OFFICES

DE GROTE ENK

Name: De Grote Enk

Location: Arnhem

Original function: office building

New function: dwellings

Architects: H.T. Zwiers (original design),
Bureau of Harmonic Architecture (re-use)

Area: 6.600 sqm

Year: mid-fifties of the twentieth century
(original design), 2006 (re-use)

DE GROTE ENK

HISTORY

This building is the former headquarters of the company AKZO Nobel and designed mid-fifties of the twentieth century by H.T. Zwiers, at that time a professor at the TU University Delft. The Buildings of professor Zwiers are characterized by the combination of traditionalism (like Amsterdams - and Delfs School), functionalistic design principles and modern building technologies by using the new mounting technologies and pre-fabricating. In the year 2006 the building was adapted into a residential building specially for starting dual earners. The design is due to the Bureau of Harmonic Architectures spread over eight floors, with 58 apartments, 9 maisonettes and 2 penthouses.⁹

BUILDING ENVELOPE

The Grote Enk is a rectangular building with measurements of 91 metres by 14.6 metres. A basement, ground floor and 8 floors with a total size of 6.600m². The building is transformed into a residential building.

COMPOSITION

The main composition of the building consist out of 3 segments. On the left a segment with a measurement of 21 by 14.6 metres and a main grid of 7 metres. The next segment lays in-between almost identical segments and has a measurement of 16.8 by 25.2 Metres. The last segment has a measurement of 49 metres by 14.6 metres. The last aberrant segment is the penthouse segment with the measurements of 18.40 metres by 7.2 metres. Inside these segments are 58 apartments, 9 maisonettes and 2 penthouses created. In the front side of the basement are storages created. On the back side of the basement are the ground floors of the maisonettes created. On the ground floor there is a main entrance with the central lobby situated, also the first floor of the 9 maisonettes.



DE GROTE ENK | ARNHEM, THE NETHERLANDS | 2006

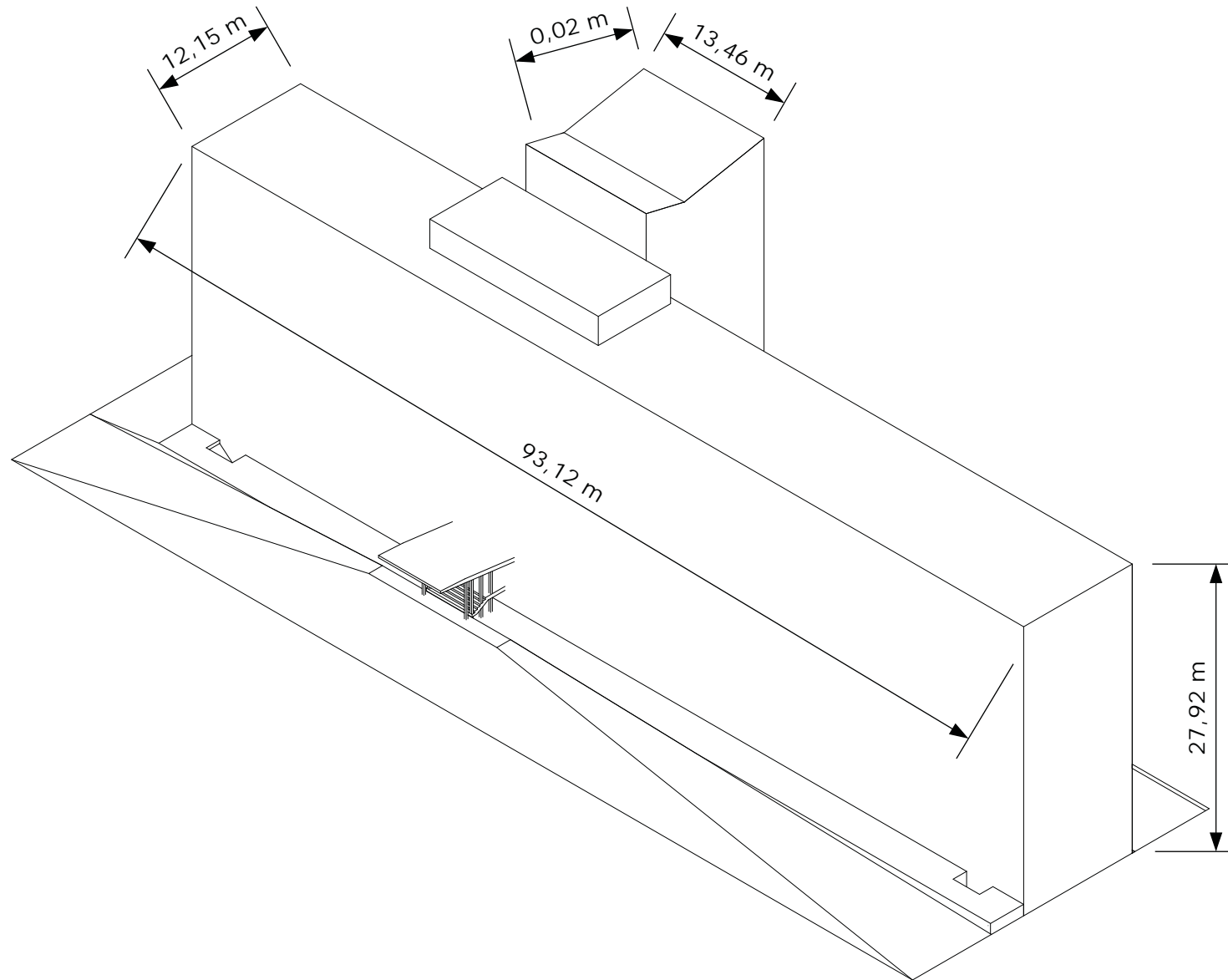

Building envelope scale 1:500 (own illustration)

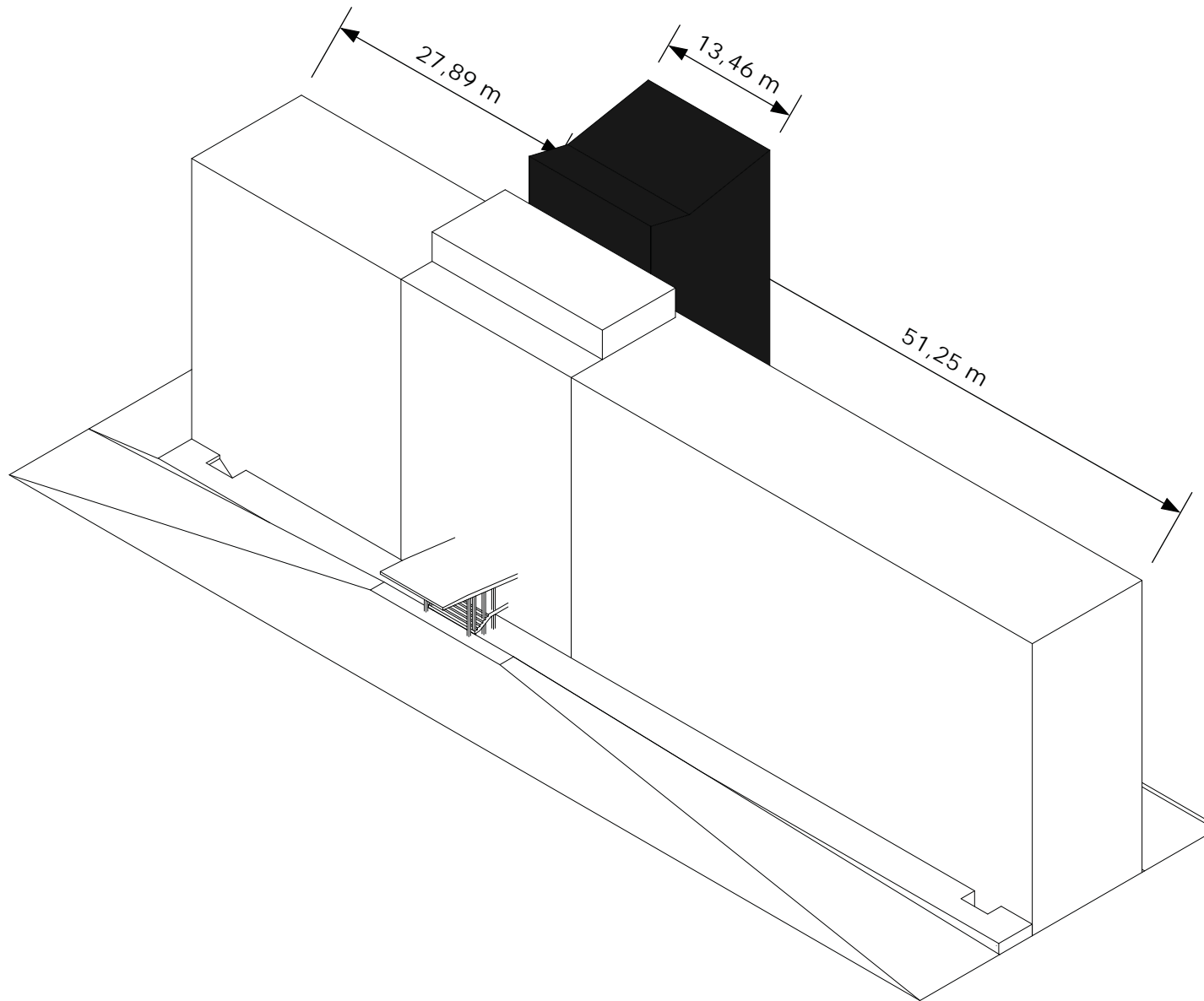

Composition scale 1:500 (own illustration)



OFFICES

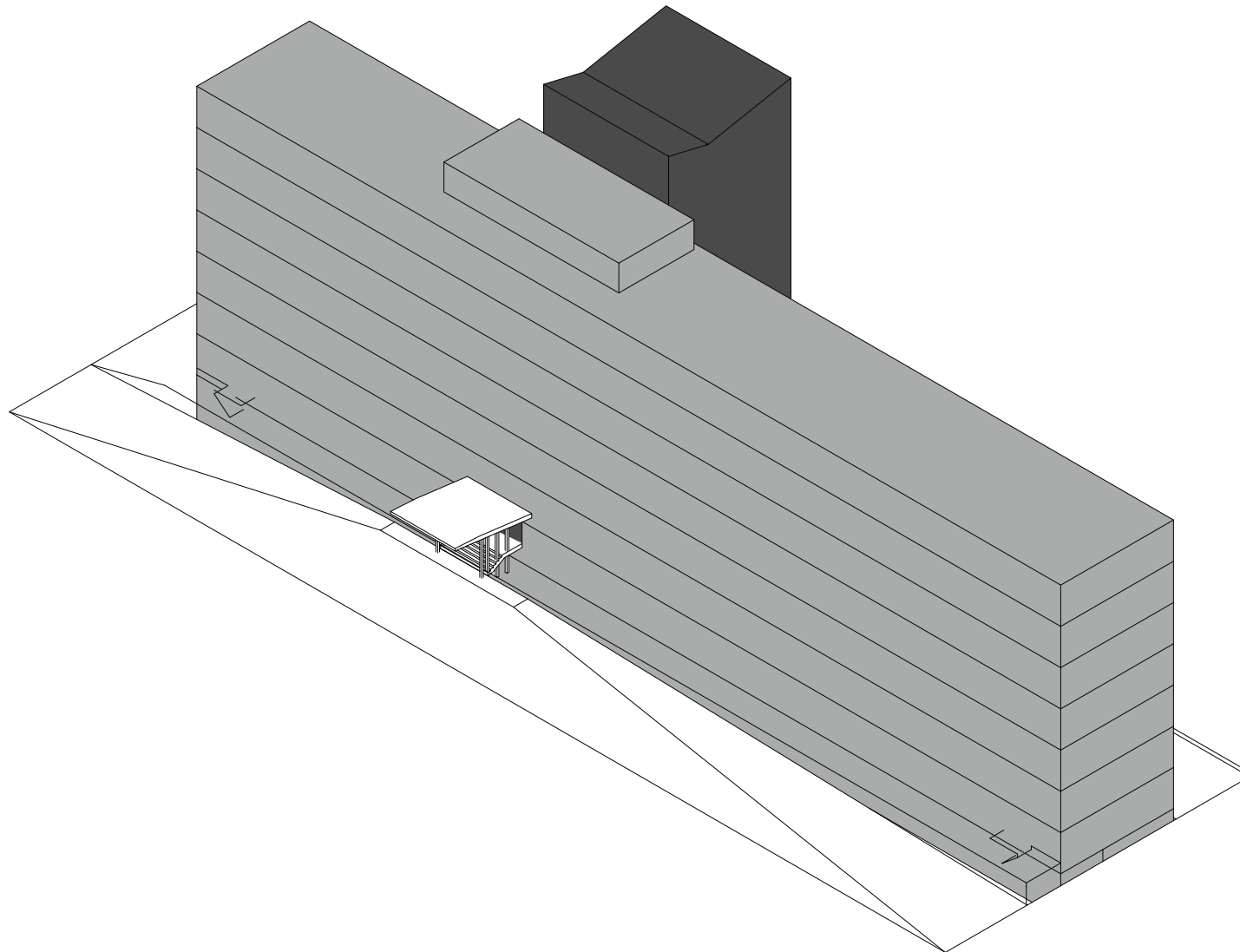

Public, collective, private scale 1:500 (own illustration)

DWELLING WITHIN THE NEW HISTORY | OFFICES

CONTENT

■ public

■ collective

■ private



OFFICES

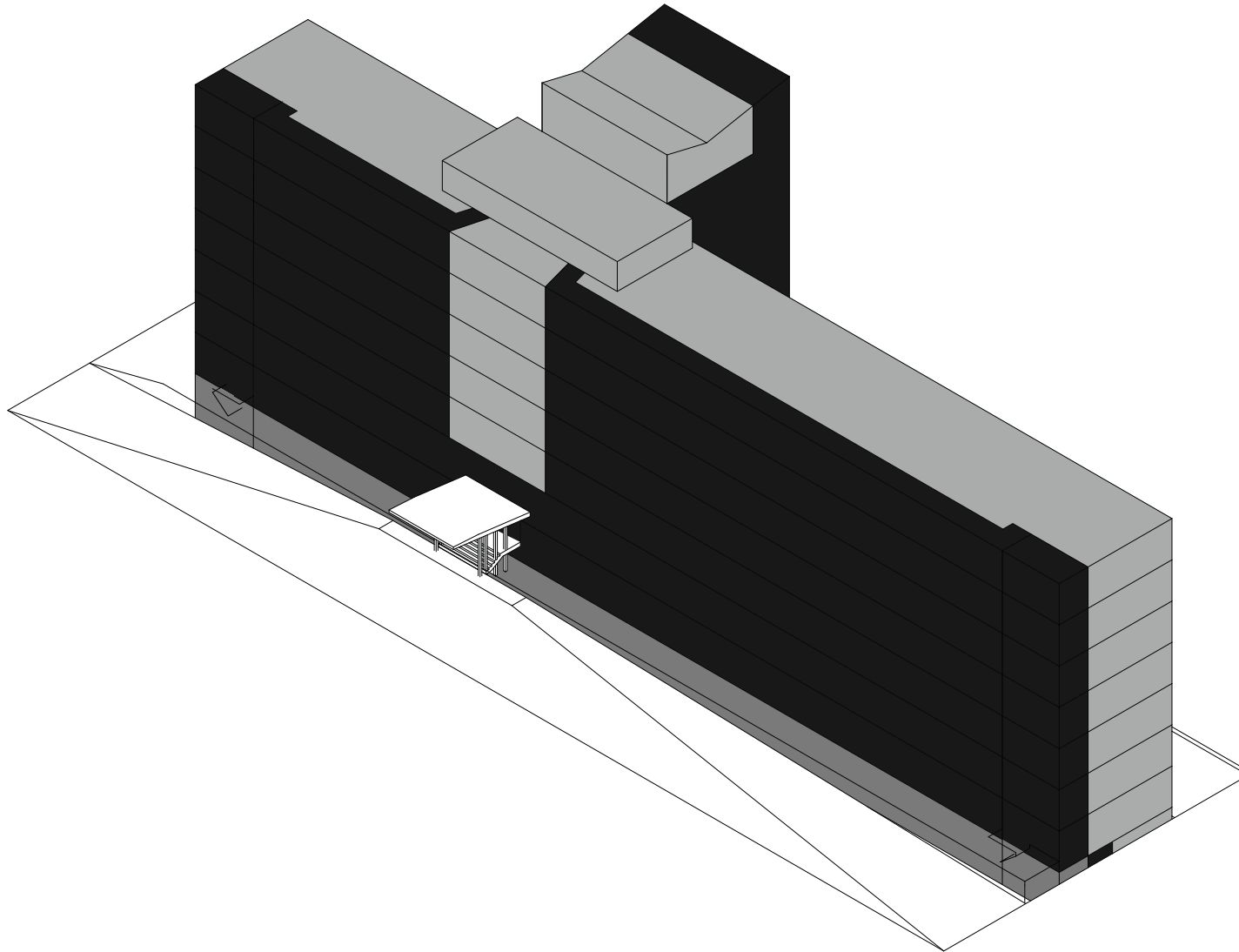

Program scale 1:500 (own illustration)

DWELLING WITHIN THE NEW HISTORY | OFFICES

CONTENT

 circulation

 storage

 dwellings



Above the ground floor are the 58 apartments created and on the top floor the maisonette penthouses. Parking places are in the front of the building created.

STRUCTURE

The structure is made possible by bearing facade walls around the building and columns in a grid of 7 meters approximately in the middle of the building. The construction of the central lobby and stairway on basement level lays on a grid of 4.2 metres, 3.45, 5.7, 3.45 and 4.2 metres and has a surrounding construction. Further up a grid of 3.45, 5.7 and 3.45 gives the stability to the stairway. The construction around the windows have a grid of 1.40 metres. The height of the levels are higher than in new build buildings only in the centre of the building the height is only 2.10 metres because of the channels and pipes.

PROGRAM

The program of the buildings consist out of storages, maisonettes and apartments with on the top floor two penthouses. The central lobby and the staircase also used as exhibition for art. Further as wrote before, the parking places are created on the front of the building.

FACADE + MATERIALS

The facade of the building, facing north and south are both made of concrete elements and at basement level of brick stones. Both sides are like the basement made of brick stones. The separation walls of the dwellings are made of Metal stud, and the walls of the storages are made of calcareous sandstone with filling. The construction is made of concrete walls or columns. A lot of glass is used in order to provide enough daylight. The stained glass facade art work on the outside of the building still remains.

CIRCULATION

The main circulation of the building is a corridor type. However the building has a main entrance that leads to the central lobby and the staircase. In the staircase are situated of course the stairs but also a normal elevator and an ambulance stretcher/fire department elevator. From here the corridor can be entered and also the apartments of the first until the sixed floor. Two staircase on the left and the right side of the building also provide an entrance to the corridors. The two penthouses/maisonettes on the top floor can be entered via the staircase. The maisonette can be entered also via an corridor on the ground floor. In the basement we can enter the storages via a corridor between the storages and dwellings.

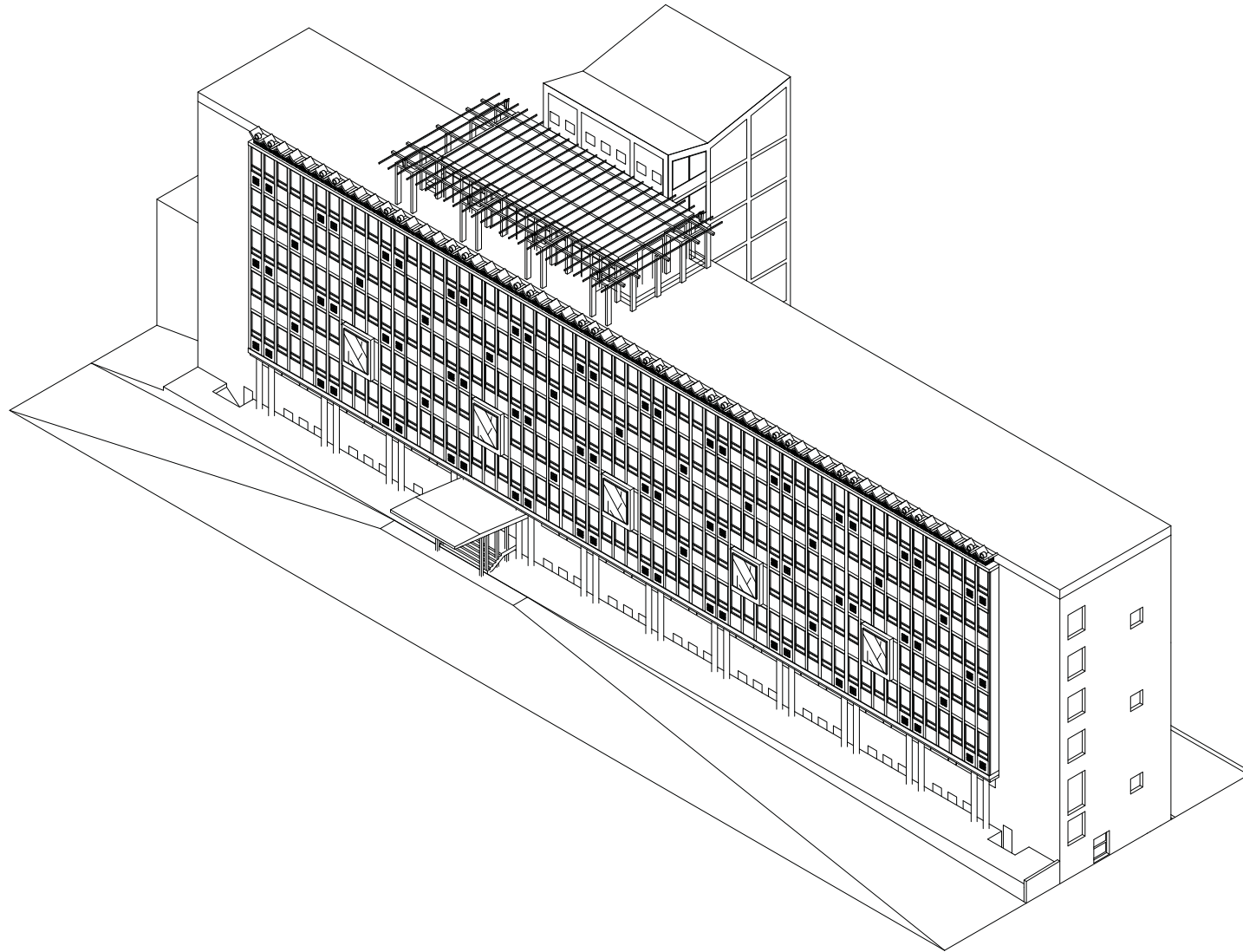

Facade scale 1:500 (own illustration)



DWELLING TYPES

Two different dwelling types are used in this building. As we know maisonette and apartments. Of course the apartments and the maisonettes have differences in size and situation. All dwellings have their own inside storage room. As accurate as possible the dwelling types are described here.

MAISONETTE TYPE 1

In this building there are two maisonette dwelling types, one on the ground floor and another at the top of the building. When entering the maisonettes on the ground floor, the living room and kitchen are situated here. The bedrooms and bathroom in the basement with an entrance to a closed terrace are situated one stair down in the basement. Each maisonette with a size between 95m² and 140m² and have the ability to create another bedroom on the ground floor or a study in the basement. All of the ground floor maisonettes are two room dwellings.



MAISONETTE TYPE 2

The maisonette/penthouse on the top floors of the building are separated in two.

The left one is a penthouse/apartment just like any apartment and the right one is an maisonette. Living room and kitchen on the seventh floor and bedrooms and bathroom on the eight floor. Both dwellings have a size between 120m² and 183m². The ground floor maisonettes are two room dwellings and the top floor maisonette is a three room dwelling. The penthouse apartment is also a three room dwelling. All maisonettes have a terrace.

APARTMENTS

From the first floor until the sixth floor we find the 58 apartments all with a size between 84m² and 110m² and all of them are three room dwellings. Except for four apartments that are situated in the extension of the staircase, every apartment has its own loggia. The kitchen is mostly situated on the corridor side of the building and the master bedroom on the loggia side of the building. When entering the apartment one bedroom is also at the corridor side of the dwelling. Because of the Metal Stud walls every apartment can be seen as a flexible dwelling.

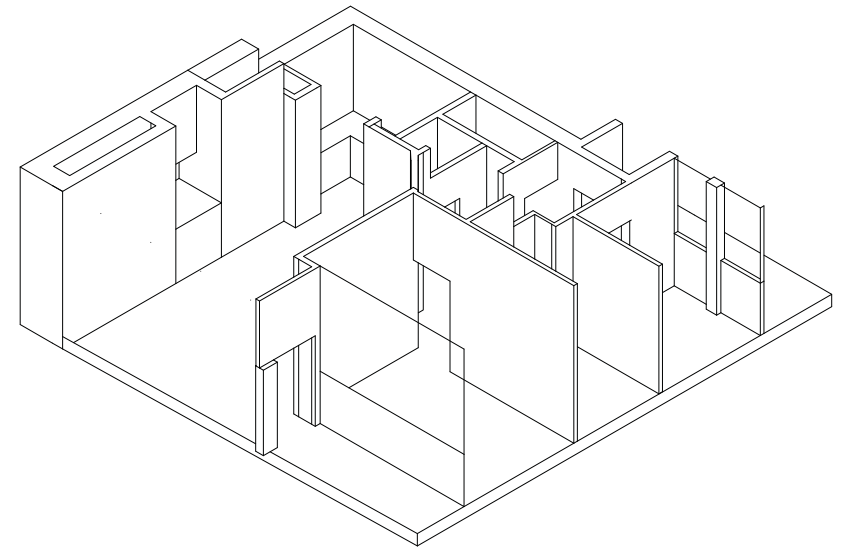
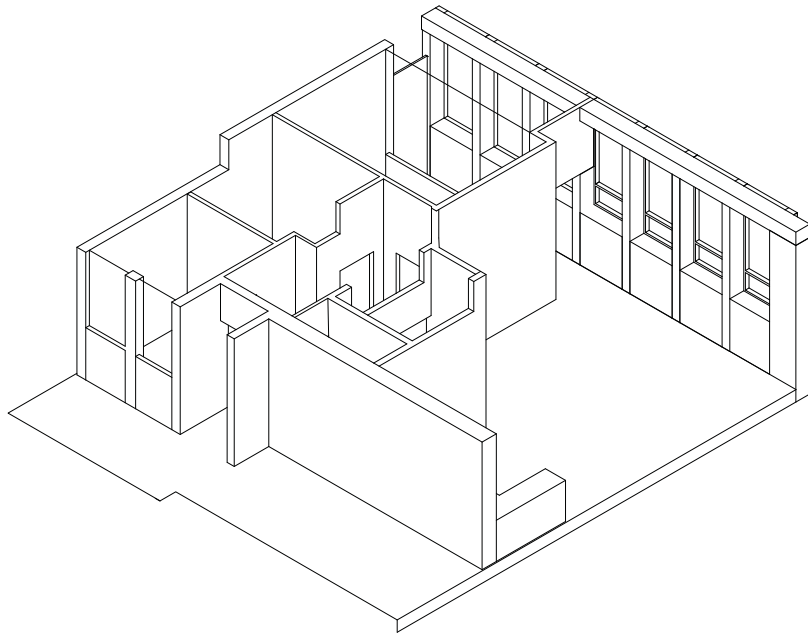

Apartment type 1 axonometry scale 1:150 (own illustration)

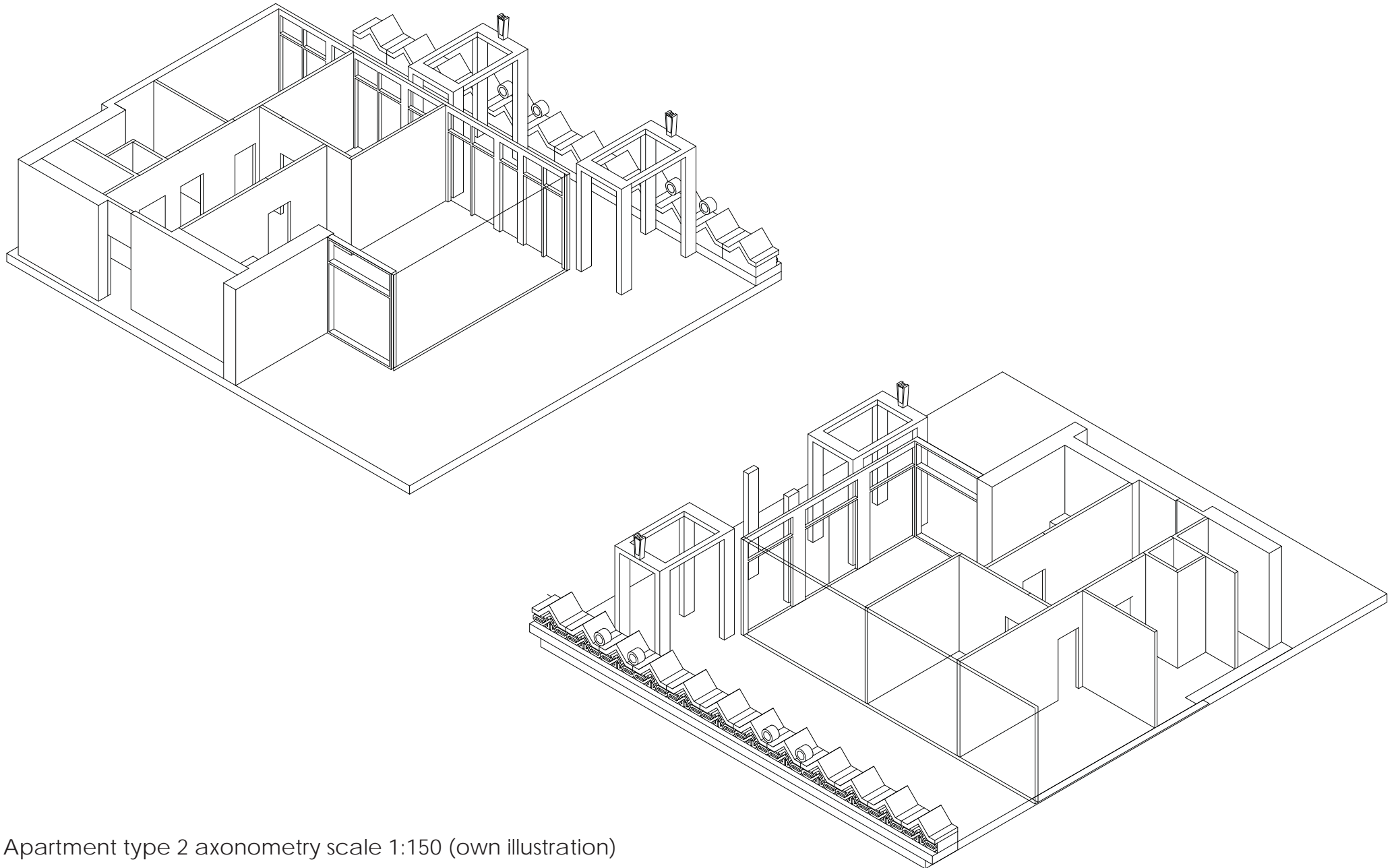
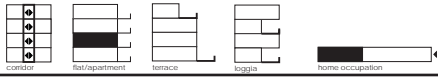

Apartment type 2 axonometry scale 1:150 (own illustration)

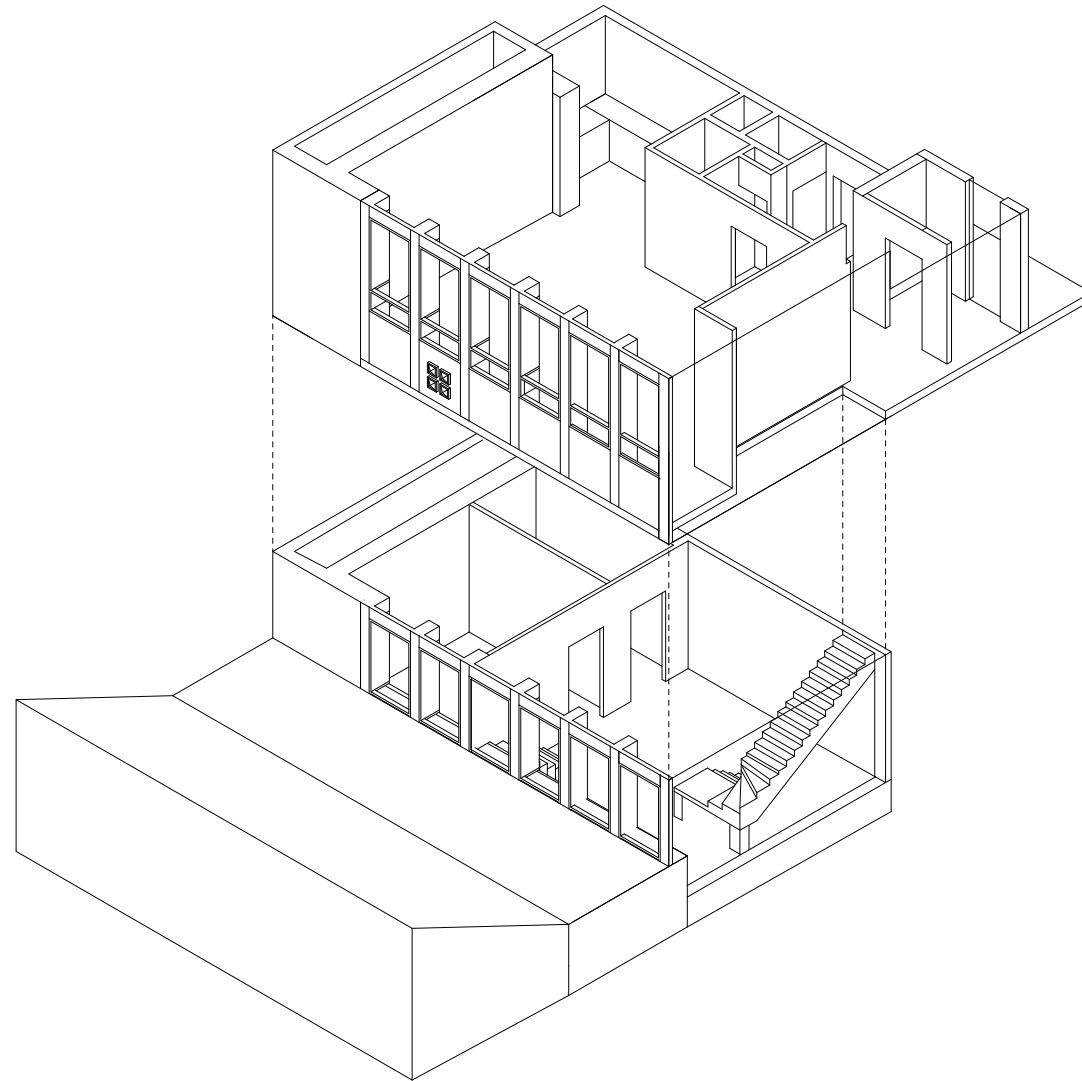

Apartment type 3 axonometry scale 1:150 (own illustration)



DAYLIGHT

With the adaptation of the building, the design is based on the principle of a dwelling with a spacious room and utilization of the high windows. Also the corridors are equipped with high windows to give the kitchen and dwellings enough daylight. Some of the dwellings around the staircase are equipped with less windows than other dwellings. Using the so-called pinstripe method, the daylight requirements can be reached. Most of the corner dwellings also have side windows that were already in the building before the adaptation.

INTERIOR

Most of all columns in the dwellings are eliminated in the interior but some of the dwellings have columns in the middle of the kitchen or hallway, but the most of the construction is in the façade of the dwellings. The dwelling separating walls and interior walls are made of Metal Stud with a thick layer of plasterboard in order to require the noise regulations. The top maisonettes have three quarters of the dwelling made of a glass façade with windows from top to bottom on the seventh floor.

OUTSIDE SPACE

The maisonettes on the ground floor have two outside spaces, one terrace in the basement and a loggia at the ground floor. The apartments at the first floor until the sixth floor have a loggia as outside space with an exception to the four dwellings above the entrance. All of the terraces and loggias we find at the south side of the building in order to give the residents the best sunlight. The designer chose loggias because balconies change the outside character of the building. At the seventh floor the maisonette and apartment both have a terrace.

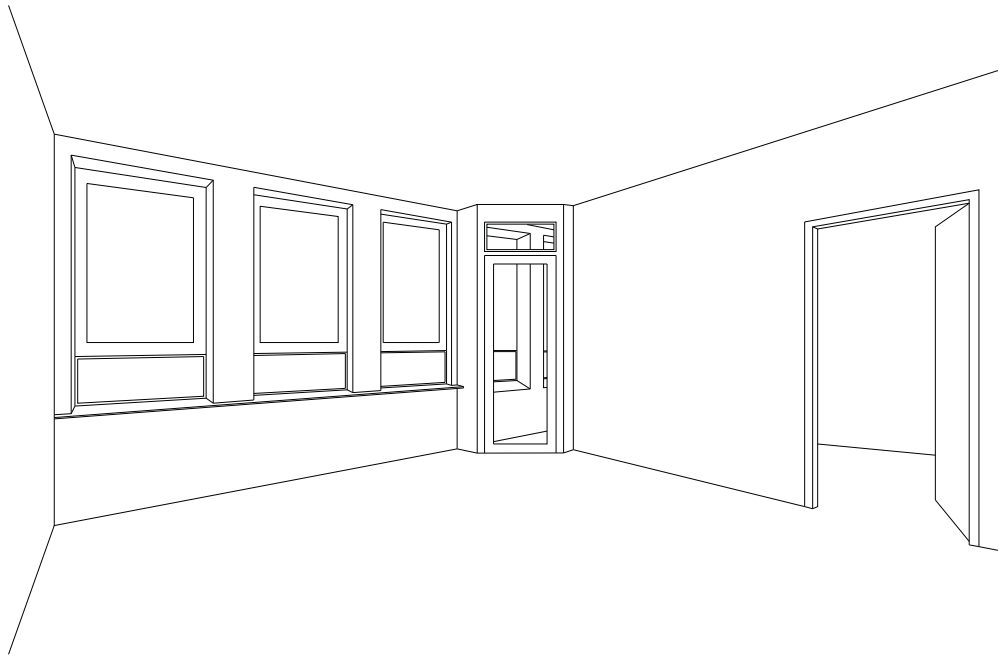

Interior dwelling (own illustration), (HuizenZoeker, 2012)



Interior dwelling (own illustration), (Funda, 2013)



CONCLUSION

Before 1980, office buildings were often built in the city center on dwelling sites or near other dwellings. Further all buildings like De Grote Enk still have the old and static character of an office building. The character of the building is often displayed by typical details like the big stained coloured glass in the front façade. These details are the visiting card for an office building. Also the art in the central lobby and entrance were used when the building still had its function as office. Also the static entrance of the building has a mark in the history of a building. These little details make it a building people want to live in.

Not only the character also the location of the building plays a big role in the willingness of an office building. These older buildings lay often near or in dwelling areas and that makes a building more wanted than a building in an office park or industrial area.

The simple structure and shape of the building makes a building like De Grote Enk an excellent building for adapting in another function. Often by putting an elevator and some extra stairs and of course some walls you can create a liveable dwelling.

This building also lends itself for different dwelling types as maisonnettes and apartments with acceptable measurements. That's why this building is adapted for starting two earners. Often smaller buildings are adapted for the target group high income and young urban professionals. Bigger buildings often be adapted for students.

However adapting a building like this is often very expensive because of the air tightness and thermal bridges. But because of the willingness the investors want to invest because of the fast return of their investment. Buildings like this often repay themselves very fast so there is a profitable investment.



OFFICES

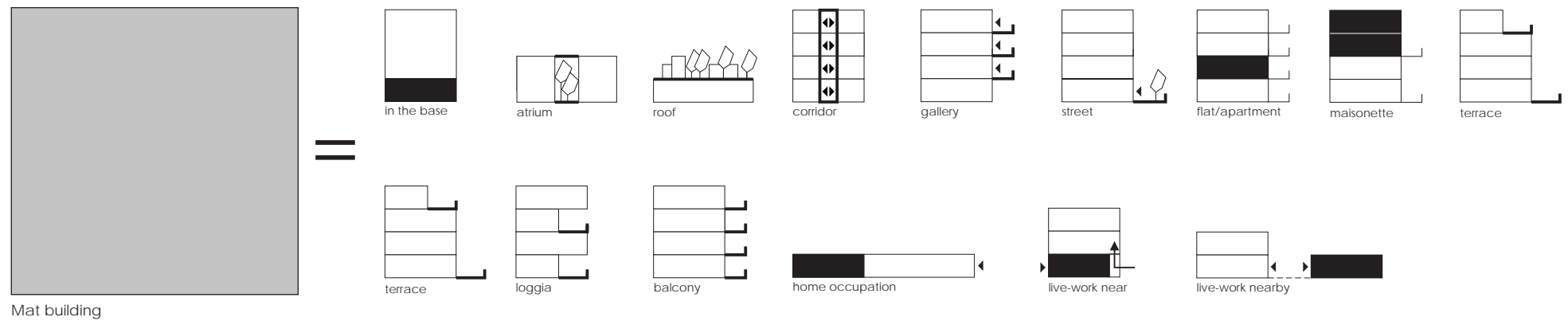
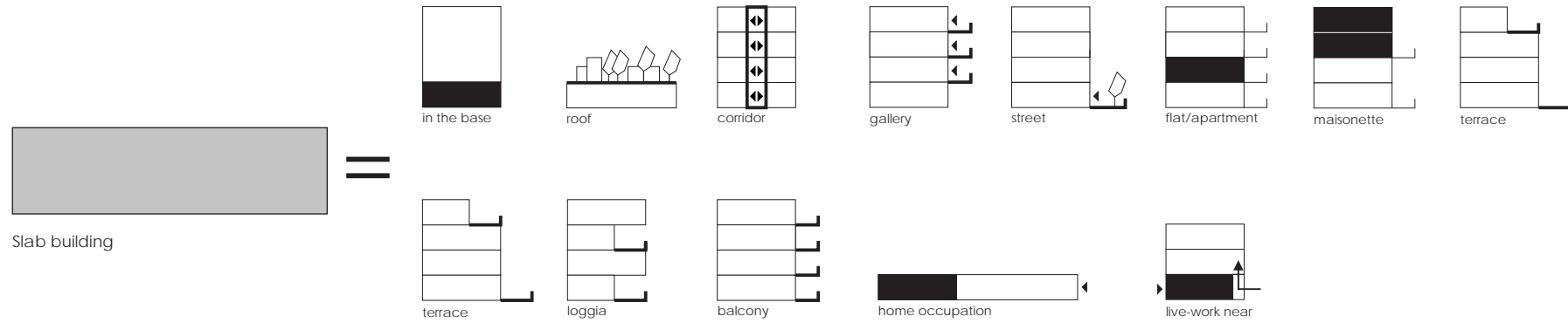

Conclusion offices (own illustration)



FOOTNOTES

1. KALK, E. 2010. *Nieuw leven voor meer gebouwen. Hergebruik kan sneller en beter*, Amsterdam, Stichting Agora Europa, (p. 78).
2. Ibidem (p. 80).
3. Ibidem (p. 79).
4. Ibidem (p. 80).
5. Ibidem (p. 79).
6. Ibidem (p. 78).
7. OUDIJK, C., REMOY, H. & VAN DER VOORDT, T. 2007. Projecten. In: VAN DER VOORDT, T. (ed.) *Transformatie van kantoorgebouwen. Thema's, actoren, instrumenten en projecten*. Rotterdam: Uitgeverij 010, (pp. 146-153).
8. Ibidem (pp. 128-134).
9. Ibidem (pp. 50-59)

LOCATION

Noticeable for all examples addressed to in this research is their location within the city centre. Industrial buildings are vacant for their location in the city centres. Buildings which are vacant due to other reasons are demolished or re-used for other purposes than residential ones, when they are located outside the city centres. Dwellers like inner city locations for their character but also for their proximity to all kind of inner city functions. Therefore, an inner city location is one of the main conditions for buildings to convert into a dwelling program.

CHARACTER

When dwellers like the character of an inner city, dwellers also like buildings with character. This character is mainly shown on the exterior of the building. Buildings made of brick masonry and with ornaments are very popular in this sense. Typical details from offices, which were applied to be their visiting cards, are now the reasons why some office buildings have better chances of surviving. A characteristic interior as within the monasteries, warehouses or gasometers also attracts new dwellers.

FACADE

Strangely enough, there seems to be a big difference in treatment of the exterior and the interior; the outer and eventual inner facade. By the inner facade is meant the facade which is adjacent to an internal space of a courtyard or atrium. The outer facade is very important for the character and attraction of a building. Internal facades are most of the time new built ones which have no relation with the already existing one what so ever. In some monasteries in Italy, complete internal facades where replaced, what did not reduced the attraction of the

building.

So, with the outer facade being maintained and the inner facade being replaced, the inter space of the building seems to propagate the new, when the exterior propagates a desire to the past.

BUILDING ENVELOPE

Transformation of a building is most successful when the scale of the buildings is quite big. An average of 50 meters in width, length and height forms a good building envelope for transformation. "*a large mass of building provides the client and the architect with greater flexibility*" (Cantacuzino, 1975, p. 27).

COMPOSITION

A big building envelope also implies adjustments for daylight penetration. The implementation of a courtyard or atrium will be an outcome to prevent dwellings to become too deep. Courtyards imply a circulation system of mainly galleries on the inside of the total building envelope, along the courtyard. Atria imply a circulation system of corridors which are also on the inside of the total building envelope, along the atria. Private outside spaces are by courtyard type buildings situated on the inside of the building. "*The courtyard plan is both compact and inward-looking.*" (Cantacuzino, 1975, p. 27) Private outside spaces are by atrium type buildings situated on the outside of the building. The atrium plan is thereby compact and two-sided orientated. It is interesting to see that lower and wider buildings are the best to convert by the use of a courtyard. We see examples of this in the courtyard chapter, warehouse chapter and cylindrical building chapter. Higher and slimmer buildings are always converted by the use of an atrium. Examples of these are explained in the warehouse chapter, cylindrical building chapter and office chapter.

STRUCTURE

From this we can conclude that buildings with a simple, non-rigid structure are most easily to adapt. Cylindrical buildings have next to a structural facade, most of the time no inner structure at all, which provides maximal freedom. Warehouses have next to a structural facade a simple inner structure of columns and beams, same as most office buildings. The courtyard buildings have a more rigid structure of a continuous cellular layout. Within this layout however, bigger spaces for communal functions are already incorporated and next to that, the courtyard already exists.

PROGRAM

Thereby buildings which are most flexible incorporate a courtyard or atria or are able to provide for them. These internal spaces are for collective or even public use. When these spaces are of quite a height, all public additional functions within the building are placed on ground floor, or at least in the base of the building. This is done to provide a separation between public and private, which enlarges the privacy within for the dwellers.

DWELLING TYPES

Typical for re-used buildings are loft type dwellings. This dwelling type shows the original structure of the building, when at the same time these dwellings have trending free floor plans. Maisonettes, which are also often realized in old buildings, are here most of the time a stacked version of the loft. The loft is a special dwelling type, because it has no division walls in it, but the old structure of the buildings. This old structure, which consists of beams and columns, combined with tactical placed service blocks insinuate room divisions. When cylindrical buildings have

no original inner structure, no lofts are realized here. The characteristics of the original building are sensible in the dwelling in monasteries, warehouses and offices. The characteristics of the original building are not sensible in the dwelling but in the communal space in the center of the building in cylindrical buildings.

DAYLIGHT

Lofts are also extra high. This is mainly due to big window openings in the old facades. This provides a lot of daylight penetration, as the courtyards or atria also do. Therefore lofts are really popular by painters and other creative persons.

CONCLUDING

Concluding oversized buildings or buildings with oversized spaces are most flexible. We will find examples of these, mostly in re-used buildings, because it is very expensive to realize lofts in new to build buildings. However, it results in nice spaces. Combined with a characteristic outer facade and structure these buildings are most durable.

CONCLUSION

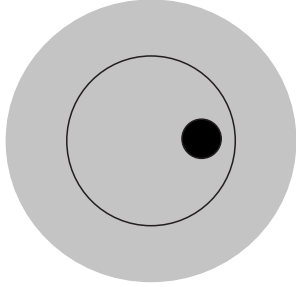
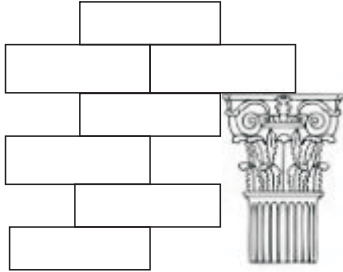
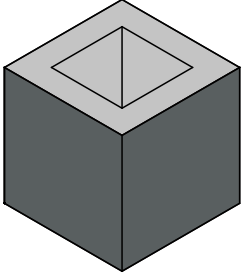
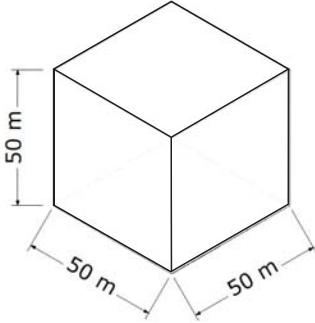
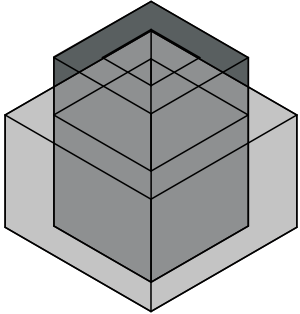
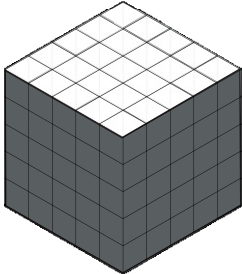
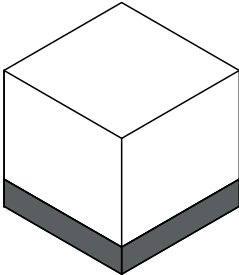
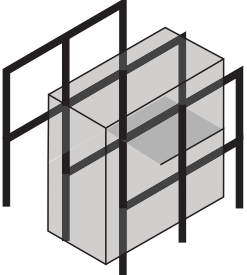
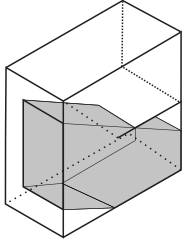
 <p>CITY CENTER</p>	<p>BRICKS</p>  <p>TYPICAL DETAILS</p>	<p>STANDARDIZED INTERIOR</p>  <p>CHARACTERISTIC EXTERIOR</p>
 <p>50 m 50 m 50 m</p>	<p>ATRIUM</p>  <p>COURTYARD</p>	<p>SIMPLE INNER STRUCTURE</p>  <p>STRUCTURAL FACADE</p>
 <p>IN THE BASE</p>	<p>VISIBLE STRUCTURE</p>  <p>LOFTS</p>	<p>EXTRA HEIGHT</p>  <p>BIG WINDOWS</p>

Toolbox (own illustration)

REFERENCE LIST

2010. Cambridge Advanced Learner's Dictionary. *Cambridge Advanced Learner's Dictionary*. Cambridge: Cambridge University Press.

9FLATS.COM. S.D. *Cozy apartment in the Gasometer* [Online]. Available: www.9flats.com [Accessed 02-01-2013].

ALTER, L. 2010. *Creative Recycling: Gasometer City* [Online]. Available: www.treehugger.com [Accessed 02-01-2013].

ANP. 2012a. *Leegstand kantoren breekt nieuw record* [Online]. Available: www.businesscompleet.nl [Accessed 28-11-2012].

ANP. 2012b. *NVM: weinig alternatieven leegstaand kantoor* [Online]. Available: www.architectenweb.nl [Accessed 28-11-2012].

AWAIS. 2007. *ING House in Amsterdam* [Online]. Available: <http://forum.xcitefun.net/ing-house-in-amsterdam-t50312.html> [Accessed 04-01-2013].

BAKKER, M. 1996. Schoorconstructie in drie dimensies zekert stabiliteit van veempand; breedplaten slim in historisch skelet verwerkt. *Bouwwereld*, 92, 26-31.

BRANDWEER AMSTERDAM-AMSTELLAND. S.D. *Van Leijenberghlaan* [Online]. Available: www.brandweer.nl/amsterdam-amstelland [Accessed 04-01-2013].

BURO VAN STIGT S.D. *Graansilo's*, Amsterdam.

BUS-IDEE. S.D. Brouwerij De Koningshoeven [Online]. Available: www.bus-idee.nl [Accessed 04-01-2013].

CAMILLE OOSTWEGEL. 2009. Fotogallerij Kruisherrenhotel Maastricht [Online]. Available: www.chateauhotels.nl [Accessed 04-01-2013].

CANTACUZINO, S. 1975. *New uses for old buildings*, London, The Architectural Press Ltd.

CANTACUZINO, S. 1989. *Re/Architecture. Old buildings/New uses*, London, Thames and Hudson.

DAAD ARCHITECTEN. 2009. Het Paleis, Groningen [Online]. Available: www.daad.nl [Accessed 28-12-2012].

DOLAN, T. 2012. *Live-work planning and design. Zero commute housing*, New York, John Wiley & Sons.

ECOFRIEND. S.D. C. F. Møller Architects transform unused silo into a residential sky rise [Online]. Available: www.ecofriend.com [Accessed 02-01-2013].

FLEXIMAP GRONINGEN. 2012. Monumenten Het Paleis, vm. chemisch lab Bloemsingel 10 [Online]. Available: <http://fleximap.groningen.nl> [Accessed 8-12-2012].

FUNDA. 2012. Handelsplein 16 [Online]. Available: www.funda.nl [Accessed 16-10-2012].

REFERENCE LIST

FUNDA. 2013. *Tivolillaan 51* [Online]. Available: www.funda.nl [Accessed 02-01-2013].

GASOMETER COMMUNITY. S.D. *Gasometer Community* [Online]. Available: www.gasometer.cc [Accessed 02-01-2013].

GASOMETER OBERHAUSEN. 2013. *Technology* [Online]. Available: www.gasometer.de [Accessed 05-01-2013].

GEMEENTE OIRSCHOT. 2009. *Deuren montfontanen klooster gaan komend weekend wijd open* [Online]. Available: www.oirschot.nl [Accessed 04-01-2013].

GROAT, L. 2002. Case studies and combined strategies. In: GROAT, L. & WANG, D. (eds.) *Architectural research methods*. New York: John Wiley & Sons.

HAWKINS, E. 2010. *Dwelling within the material city*, Alexandria, Washington Alexandria Architecture Center.

HEIDEGGER, M. 1971. *Poetry, language, thought*, New York, Harper & Row.

HENDRIKX, S. 2008. *Kloosters als religieus erfgoed. Bouwstenen voor een te voeren beleid*, Utrecht, Uitgeverij Matrijs.

HUIZENZOEKER. 2012. *Tivolillaan 165* [Online]. Available: www.huizenzoeker.nl [Accessed 02-01-2013].

JACOBS, J. 1992. *The death and life of great American cities*, New York, Random House.

JÜRGENHAKE, B., LEUPEN, B., MOOIJ, H., NOTTROT, R., UYTENHAAK, R. & ZONDAG, J. 2005. *Het ontwerpen van woningen*, Delft, Publicatiebureau Bouwkunde.

KALK, E. 2010. *Nieuw leven voor meer gebouwen. Hergebruik kan sneller en beter*, Amsterdam, Stichting Agora Europa.

LAMBERT KAMPS ART & DESIGN. S.D. *Hotelkamer* [Online]. Available: www.lambertkamps.com [Accessed 23-12-2012].

LINTSEN, H. W. 1992. *Geschiedenis van de techniek in Nederland. De wording van een moderne samenleving 1800-1890. Deel I: Techniek en modernisering. Landbouw en voeding*, Zutphen, Walburg Pers.

LINTSEN, H. W. 1993a. *Geschiedenis van de techniek in Nederland. De wording van een moderne samenleving 1800-1890. Deel II: Gezond en openbare hygiëne. Waterstaat en infrastructuur. Papier, druk en communicatie*, Zutphen, Walburg Pers.

LINTSEN, H. W. 1993b. *Geschiedenis van de techniek in Nederland. De wording van een moderne samenleving 1800-1890. Deel III: Textiel. Gas, licht en elektriciteit*. Bouw, Zutphen, Walburg Pers.

MØLLER, C. P. S.D. *Silbetten* [Online]. Available: www.cfmoller.com [Accessed 05-01-2013].

MULDER, M. 2012. Goedkoop huis in verramsjt kantoor. *Het Parool*, 10 May.

REFERENCE LIST

MVRDV. 2005. *Inside-out Silos Copenhagen* [Online]. Available: www.archined.nl [Accessed 02-01-2013].

MVRDV. S.D. *Gemini residences - Frøsilø* [Online]. Available: www.mvrdv.nl [Accessed 04-01-2013].

NATIONALE RENOVATIE PRIJS. 2005. *Marci Panis*, Amsterdam [Online]. Available: www.nationalerenovatieprijs.nl [Accessed 04-01-2013].

NEDERLANDSE WATERTOREN STICHTING. 2002-2011. *Herbestemming* [Online]. Available: www.watertorens.nl [Accessed 05-01-2013].

NIELSEN, R. R. 2010. *Frøsilos* [Online]. Available: www.mimoo.eu [Accessed 02-01-2013].

OUDIJK, C., REMØY, H. & VAN DER VOORDT, T. 2007. Projecten. *In: VAN DER VOORDT, T. (ed.) Transformatie van kantoorgebouwen. Thema's, actoren, instrumenten en projecten*. Rotterdam: Uitgeverij 010.

POON, C. S. S.D. *Gasometer City, Vienna, Austria* [Online]. Available: www.cse.polyu.edu [Accessed 02-01-2013].

RIJKSDIENST VOOR HET CULTUREEL ERFGOED. S.D. *Beschrijving Het Veem* [Online]. Available: <http://rijksmonumenten.nl> [Accessed 29-12-2012].

SCHLIMBACH, J. 2008. Kunstenaars zoeken chemie in Het Paleis. *Dagblad van het Noorden*.

SOETERS VAN ELDONK ARCHITECTEN. S.D. *Halfweg - Herontwikkeling suikersilo's 2002>2009* [Online]. Available: www.soeters-vaneldonk.nl [Accessed 04-01-2013].

STEENHUIS, M. & MEURS, P. 2011. *Herbestemming in Nederland. Nieuw gebruik van stad en land*, Rotterdam, NAI Uitgevers.

STRAATKAART. 2009. *Het Sieraad - Zuidzijde* [Online]. Available: <http://straatkaart.nl> [Accessed 04-01-2013].

TER BORCH, I. 2001. *Herbestemming van Graansilo's blijkt succesformule*. *Renovatie & Onderhoud*, 30-33.

TIVOLIS VENNER. S.D. *Tivolis højhusprojekt* [Online]. Available: www.tivolisvenner.dk [Accessed 05-01-2013].

VAN HULTEN, A. 1985. *Werkstad: 30 industriële monumenten in Rotterdam*, Rotterdam, Stichting industrieel erfgoed Rijnmond.

VAN MERWIJK, T. 2007. *Brandweergarages en -kazernes. Categorieel onderzoek wederopbouw 1940-1965*. Zeist: Rijksdienst voor Archeologie Cultuurlandschap en Monumenten.

VOLLAARD, P. 1993. *Cepezed architecten*, Rotterdam, 010 Publishers.

WANG, D. 2002. Theory in relation to method. *In: GROAT, L. & WANG, D. (eds.) Architectural research methods*. New York: John Wiley & Sons.

REFERENCE LIST

WATERTOREN IJMUIDEN. S.D. *Appartementen - Loft aan de Wassertorenpad in Ijmuiden* [Online]. Available: www.watertorenijmuiden.nl [Accessed 05-01-2013].

WIENER GASOMETER. S.D.-a. *1985 Die Gasometer gehen in Ruhestand* [Online]. Available: www.wiener-gasometer.at/de [Accessed 02-01-2013].

WIENER GASOMETER. S.D.-b. *Die Mauer der Gasometer* [Online]. Available: www.wiener-gasometer.at/de [Accessed 02-01-2013].

WIENER GASOMETER. S.D.-c. *Wiener Tradition und Bauweise* [Online]. Available: www.wiener-gasometer.at/de [Accessed 02-01-2013].

WIENER GASOMETER C. S.D. *Gasometer C* [Online]. Available: www.wiener-gasometer.at [Accessed 02-01-2013].

WIKIPEDIA. S.D. *Scheepvaarhuis* [Online]. Available: <http://nl.wikipedia.org> [Accessed 04-01-2013].

WORTMANN, A. 1997. 200 meter stad: het Entrepotgebouw op de kop van zuid. *Archis*, 64-68.

YIN, R. 1994. *Case study research: design and methods*, Thousand Oaks, Sage publications.

ZECC ARCHITECTEN S.D. *Woonwatertoren Soest*. Utrecht: Zecc Architecten.