



P5 Presentation “The Place of Work”

Daan Vulkers

1. Introduction

2. Strategy

3. Design

Public

Meeting

Working



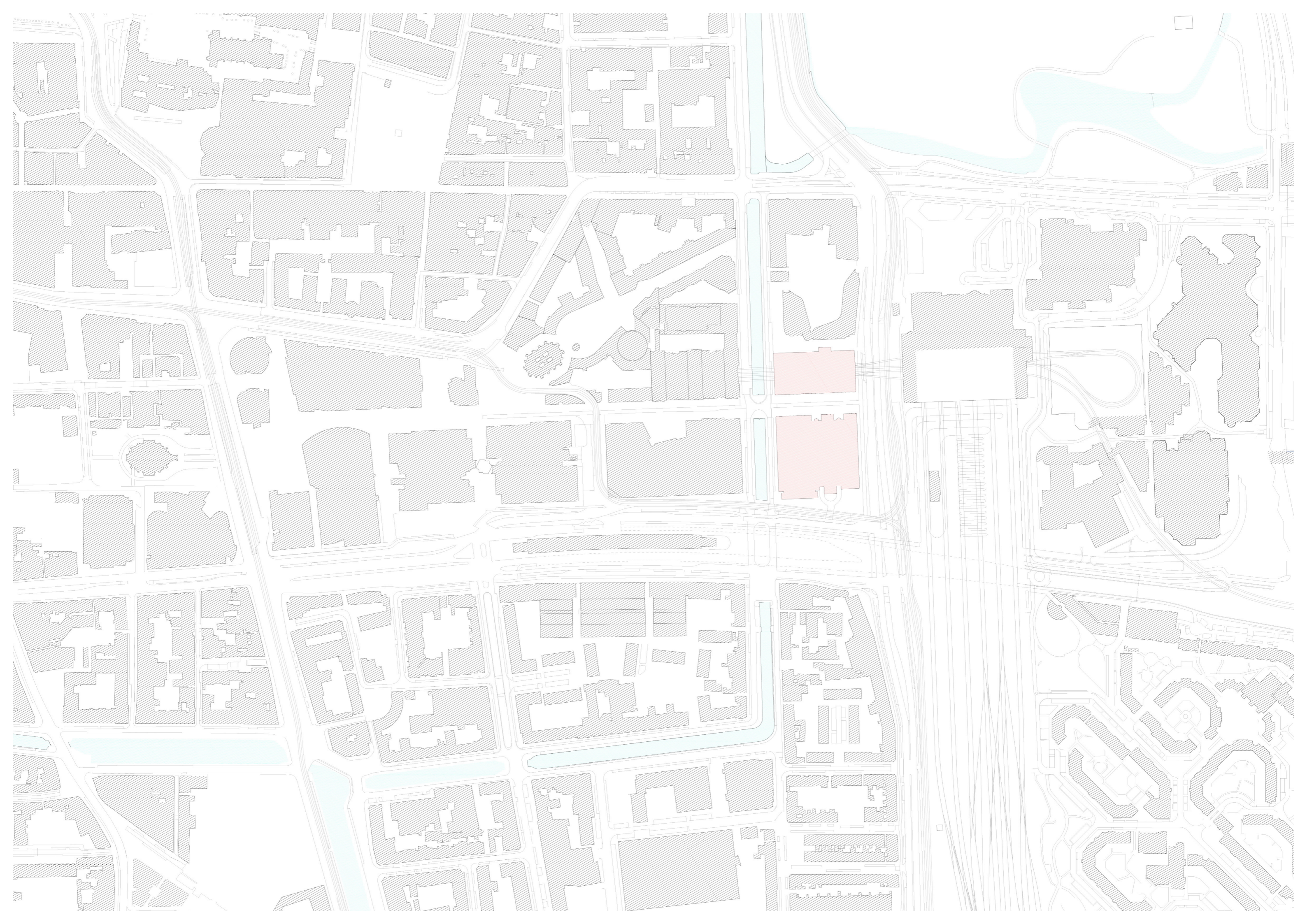

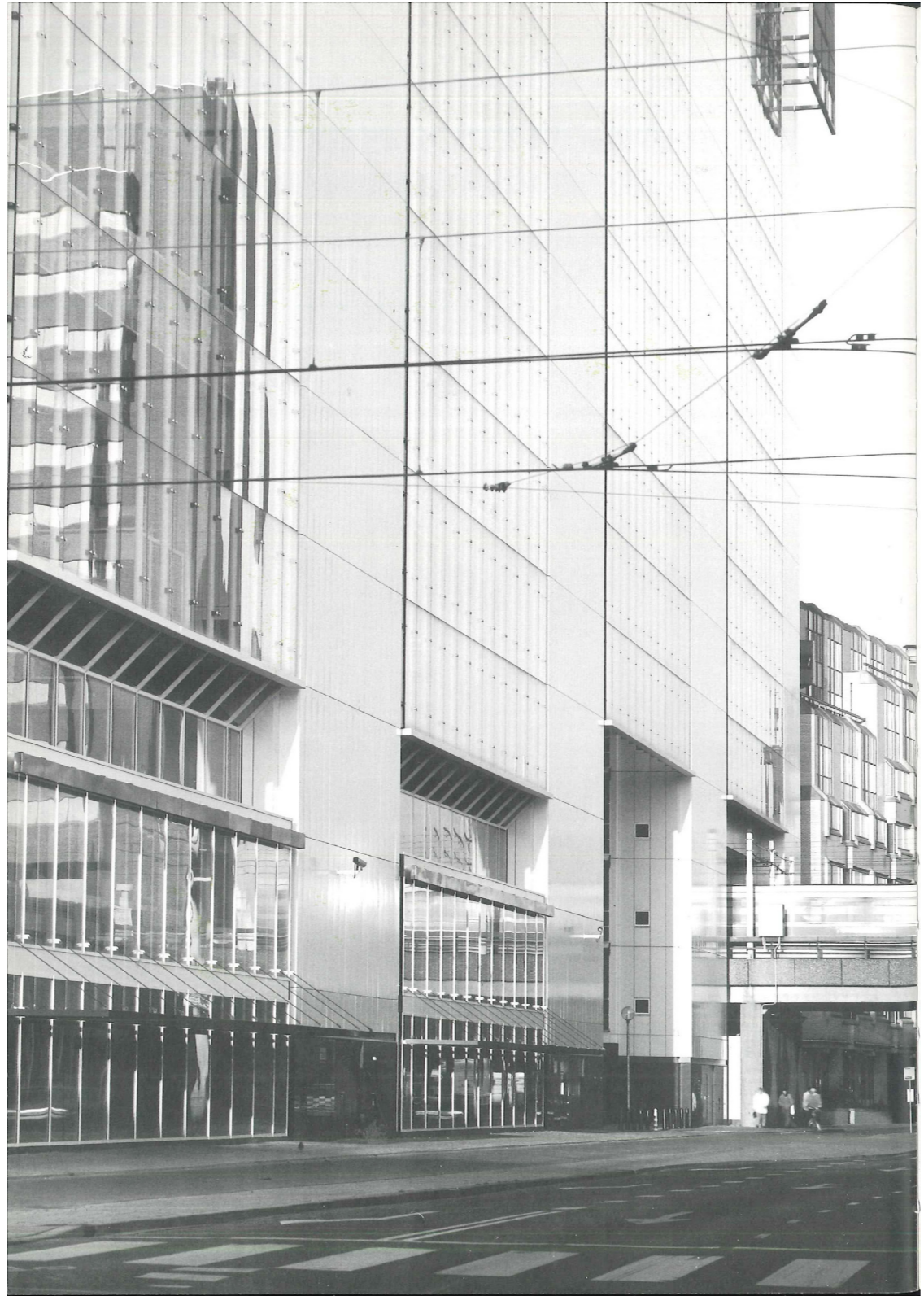









Seagram Building - Mies van der Rohe & Philip Johnson - photo by Ezra Stoller - 1958



Office interior Inland Steel - Skidmore, Owings & Merrill - photo by Ezra Stoller - 1958



Office in a Small City - Edward Hopper 1953



Office layout according to Taylorist principles USA 1920s



Larkin Building - Frank Lloyd Wright - 1905

Bouwstenen	m ² fno/ plek	m ² fno/ bouw- steen	Aantal bouw- stenen	Aantal stoelen	Aantal werkp'n	% aantal wp'n
Basiswerkplekken						
Open 2 persoons	6,0	12	41	82	82	8,1
Open 4 persoons	6,0	24	20	80	80	7,9
Halfopen 2 persoons	6,0	12	35	70	70	6,9
Halfopen 4 persoons	6,0	24	18	72	72	7,1
Gesloten 2 persoons	6,0	12	49	98	98	9,7
Gesloten 4 persoons	6,0	24	24	96	96	9,5
Concentratie 1 persoons	6,0	6	55	55	55	5,4
Concentratie 4 persoons	6,0	24	12	48	48	4,7
Aanland 2 persoons	6,0	12	35	70	70	6,9
Aanland 4 persoons	6,0	24	18	72	72	7,1
Telefoon	2,5	2,5	11	11	11	1,1
Totaal				754	754	74,4
Ontmoetingswerkplekken						
Open 4 persoons	2,5	10	18	72	36	3,6
Open 6 persoons	2,5	15	12	72	36	3,6
Gesloten 4 persoons	2,5	10	14	56	28	2,8
Gesloten 6 persoons	2,5	15	10	60	30	3,0
Lounge 2-4 persoons		8	76	152	76	7,5
Projecttafel 6 persoons	2,5	15	17	102	51	5,1
Totaal				514	257	25,6
Totaal				1268	1011	100,0

Research seminar: "Workplacemix" from brief

CLOSED

A. Gesloten werkplek:
2 personen

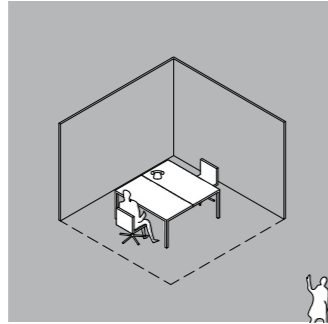

B. Gesloten werkplek:
4 personen

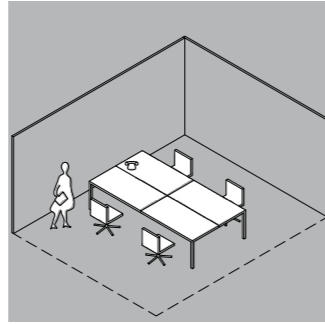

CONCENTRATION

C. Concentratie ruimte:
1 persoon

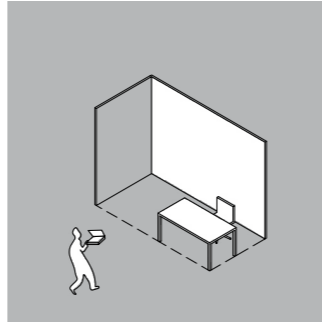

D. Concentratie ruimte:
4 personen

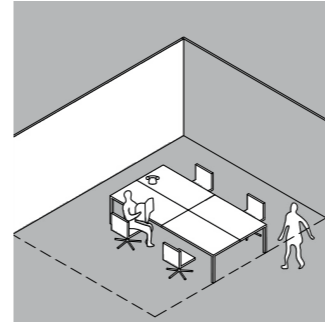

HALF-OPEN

E. Halfopen werkplek:
2 personen

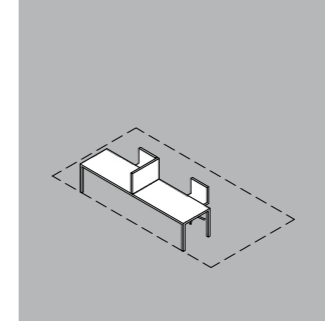

F. Halfopen werkplek:
4 personen

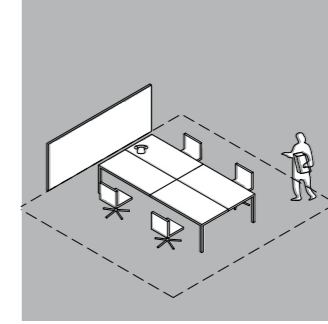

OPEN

G. Open werkplek:
2 personen

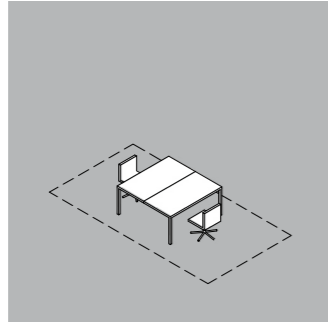

H. Open werkplek:
4 personen

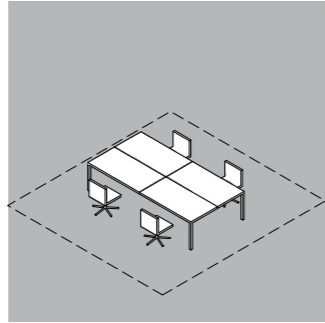

'TEMPORARY'

I. Aanlandplek:
2 personen

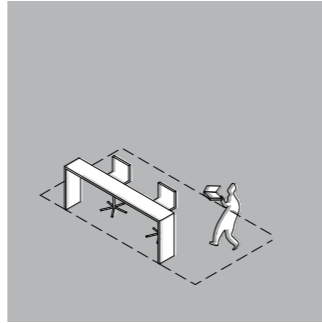

J. Aanlandplek:
4 personen

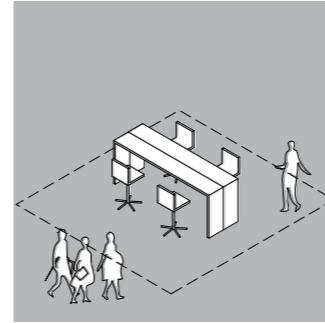

Research seminar: "Workplacemix" visualization by OMA

Questionnaire: Which types of workspaces are missing?

*“A space with a more **homely atmosphere** for meeting.”*

*“A temporary space that is also for concentration (silent), like a **library**.”*

*“Seats in the form of a **‘train compartment’**: two couches that are facing each other. These places I really like for meeting.”*

*“A ‘creative’ space for quick meetings, for example **standing places**.”*

*“I can imagine that there’s a **large table** for meeting with more than four people or a standing table where you can have a **quick** meeting or put down your laptop.”*

The answers all refer to places, types or atmospheres outside of the working environment.



Uffizi - Giorgio Vasari - 1560



Uffizi, Giorgio Vasari 1560



Uffizi, Giorgio Vasari 1560

Strategy

Existing building

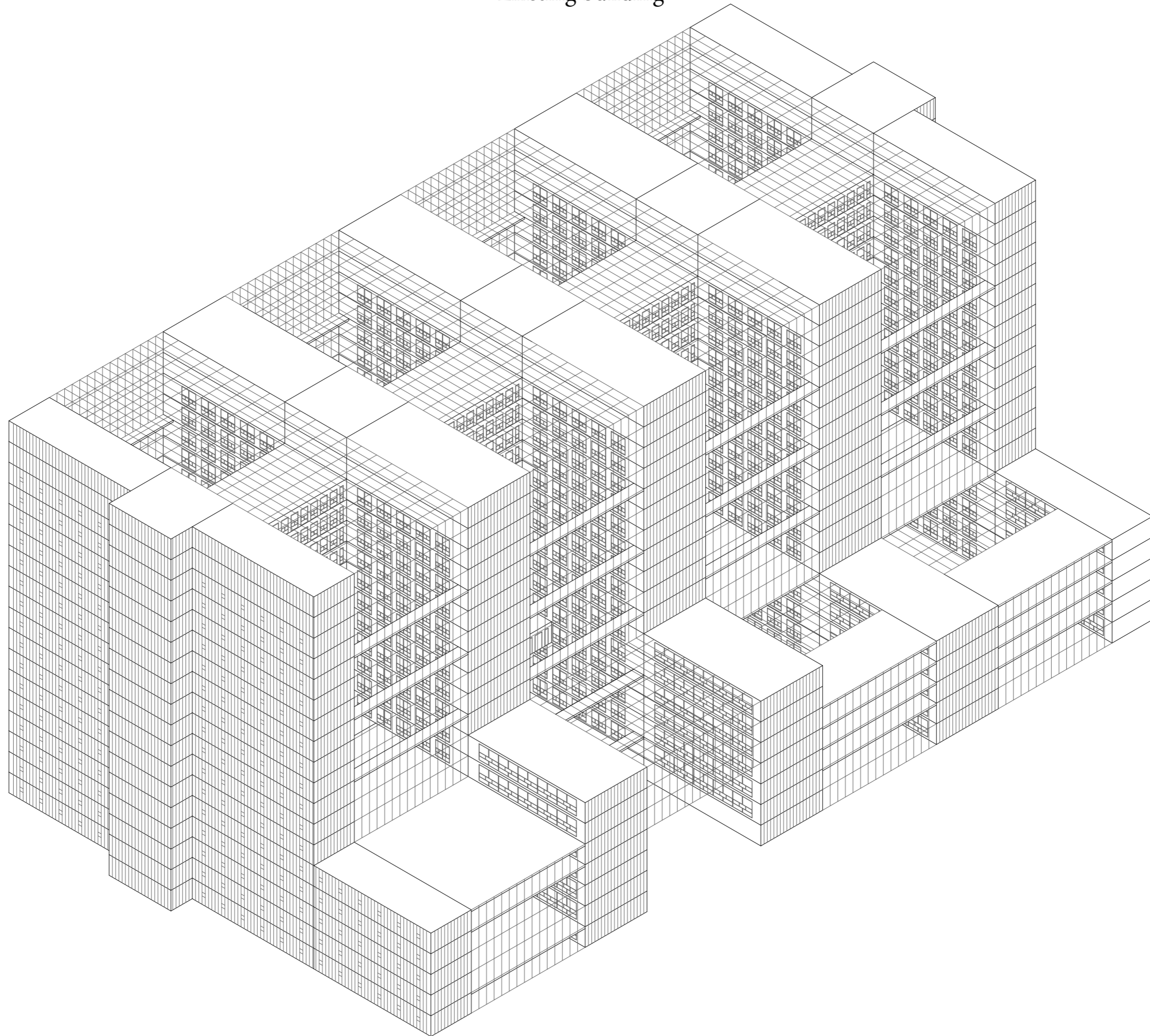

Redesign

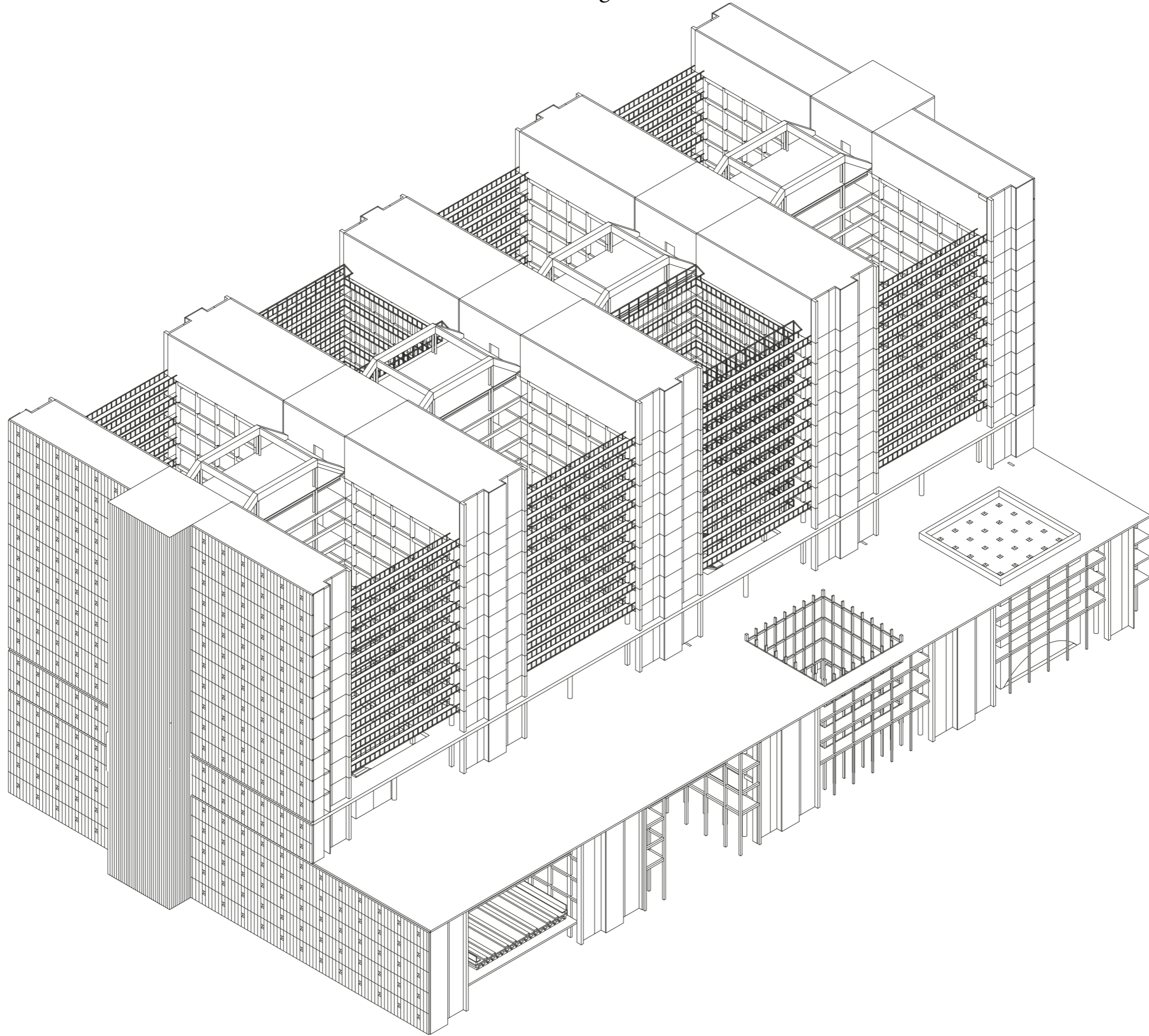

Public place of work

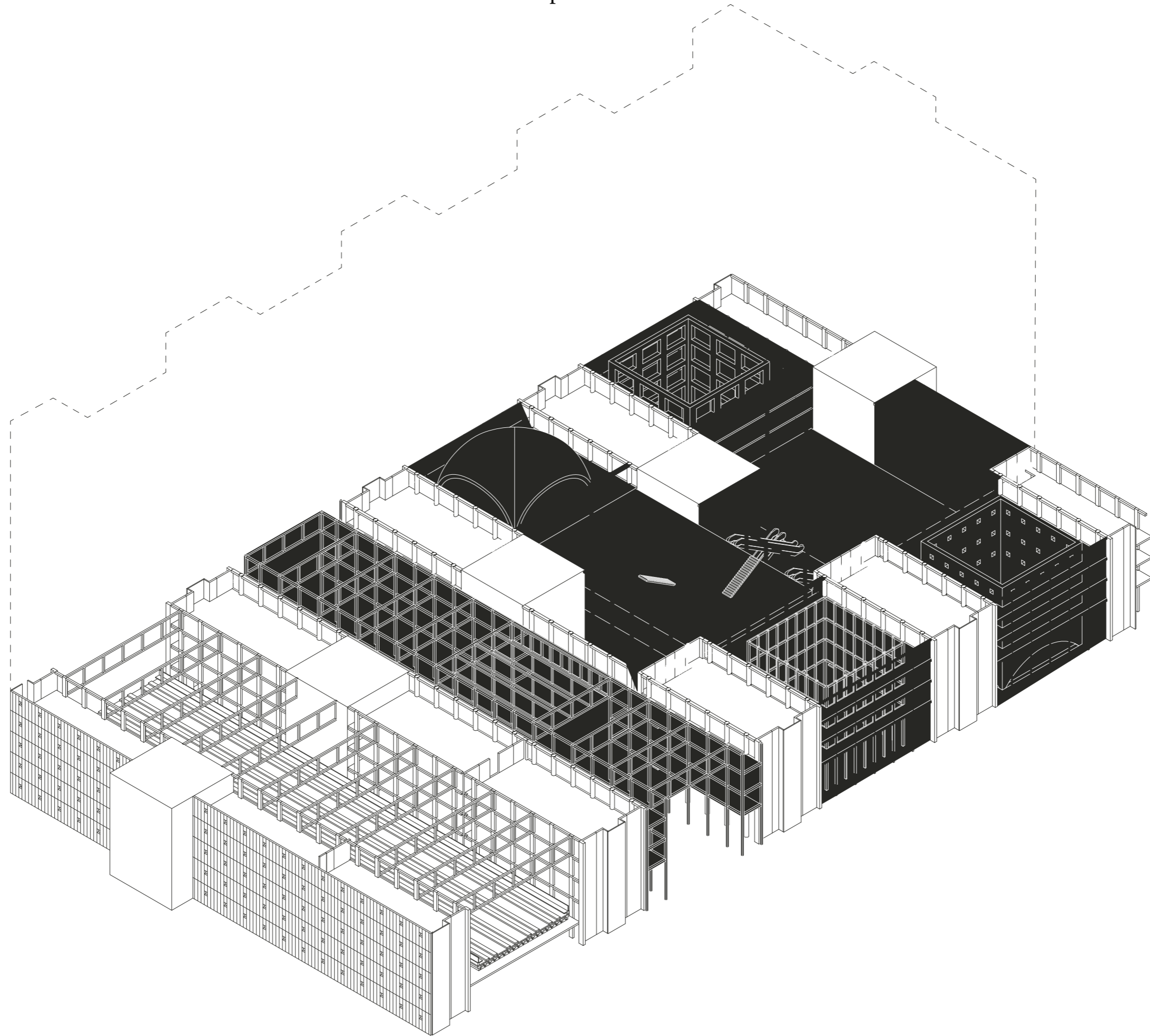

Meeting floor

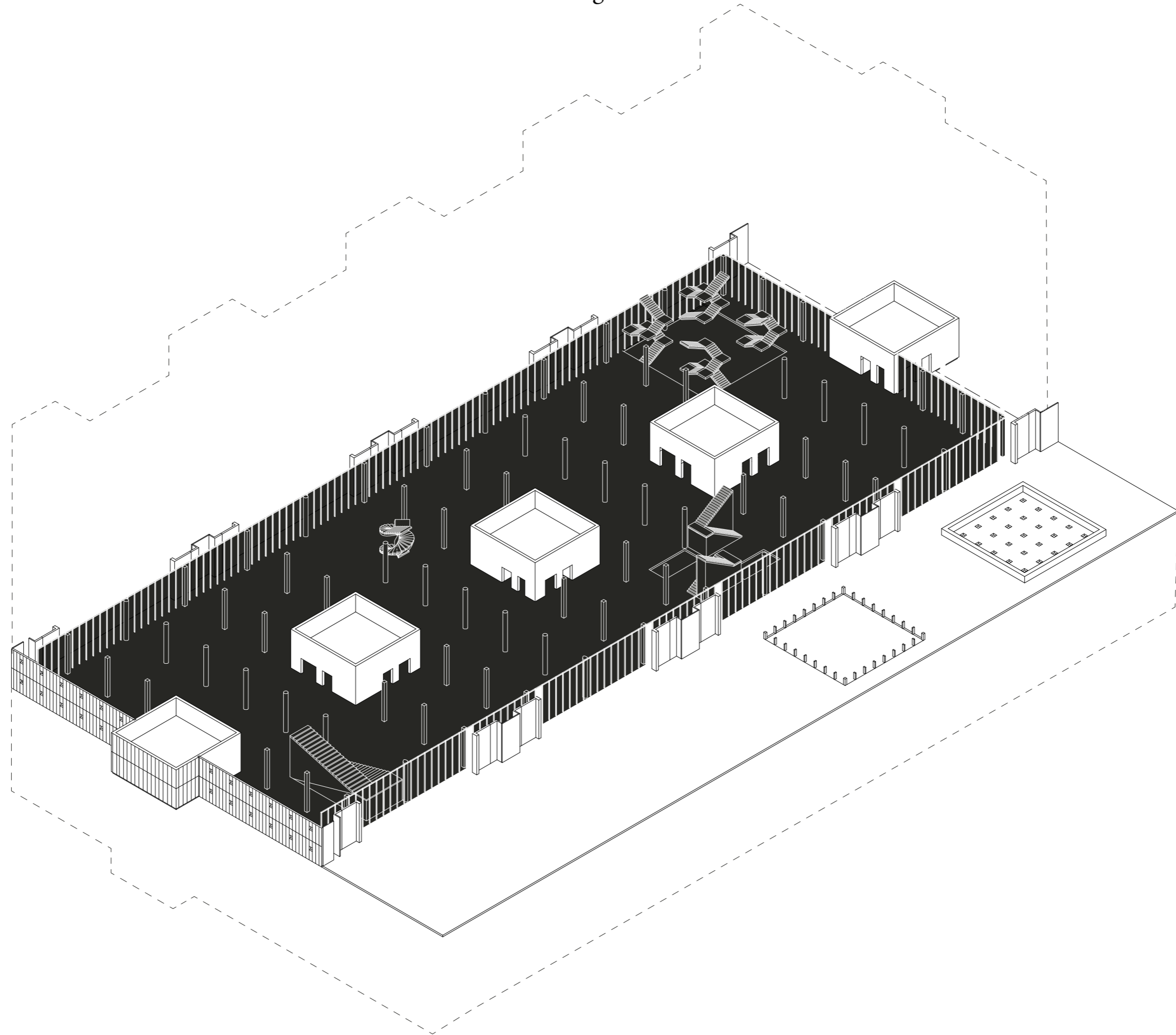

Working

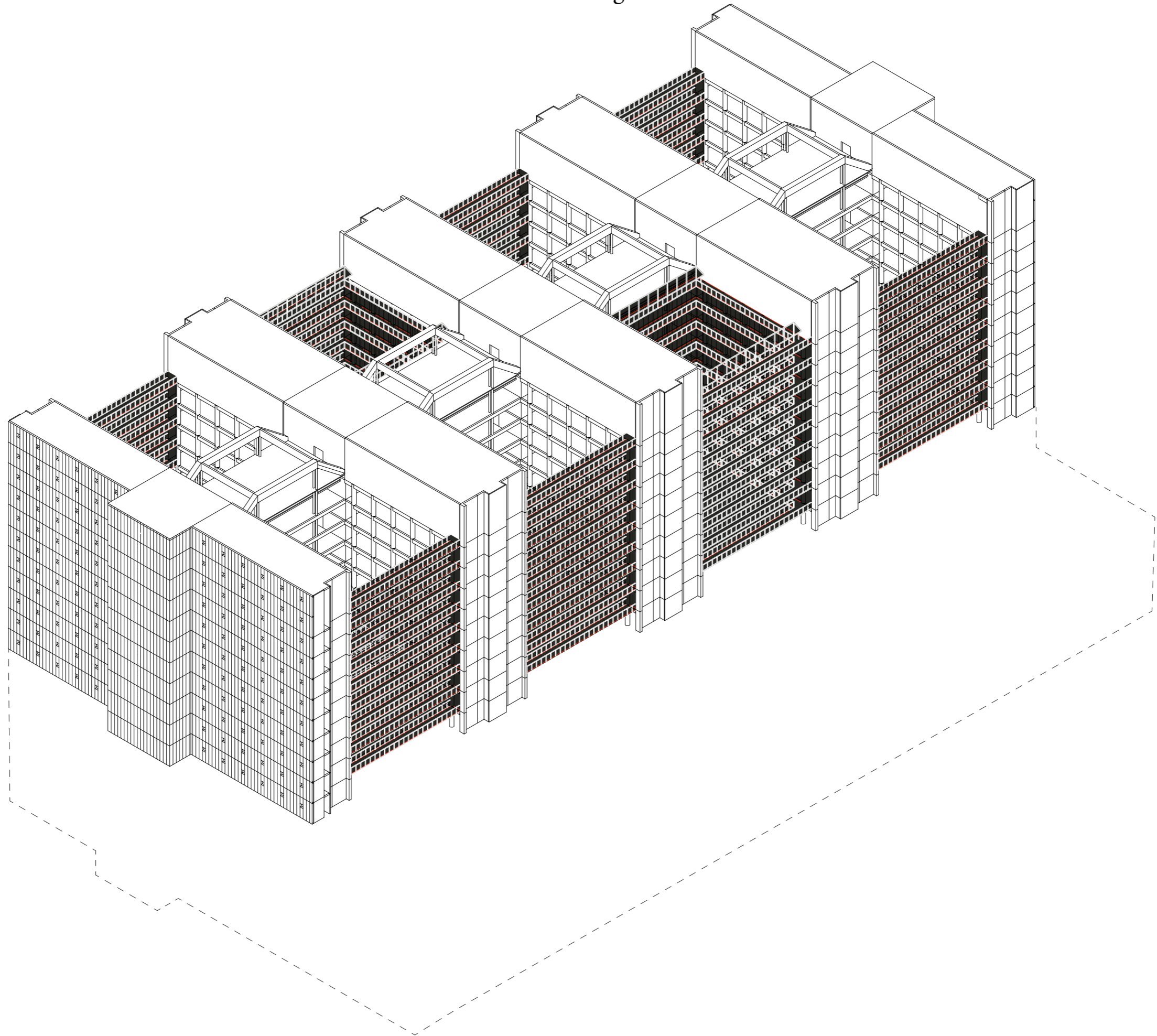

Exploded Axonometric view of added construction

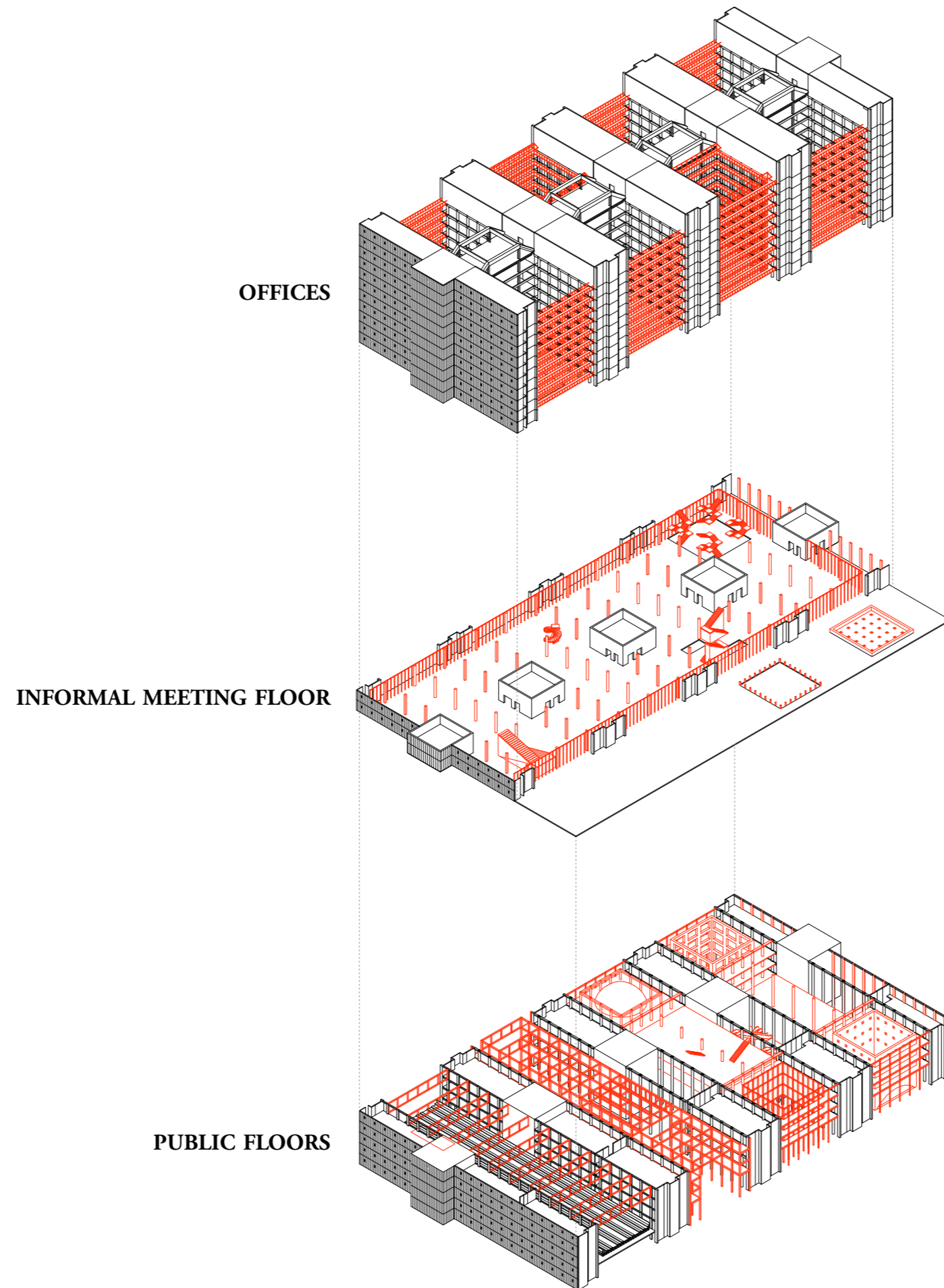

Design Proposal
Public

Public spaces

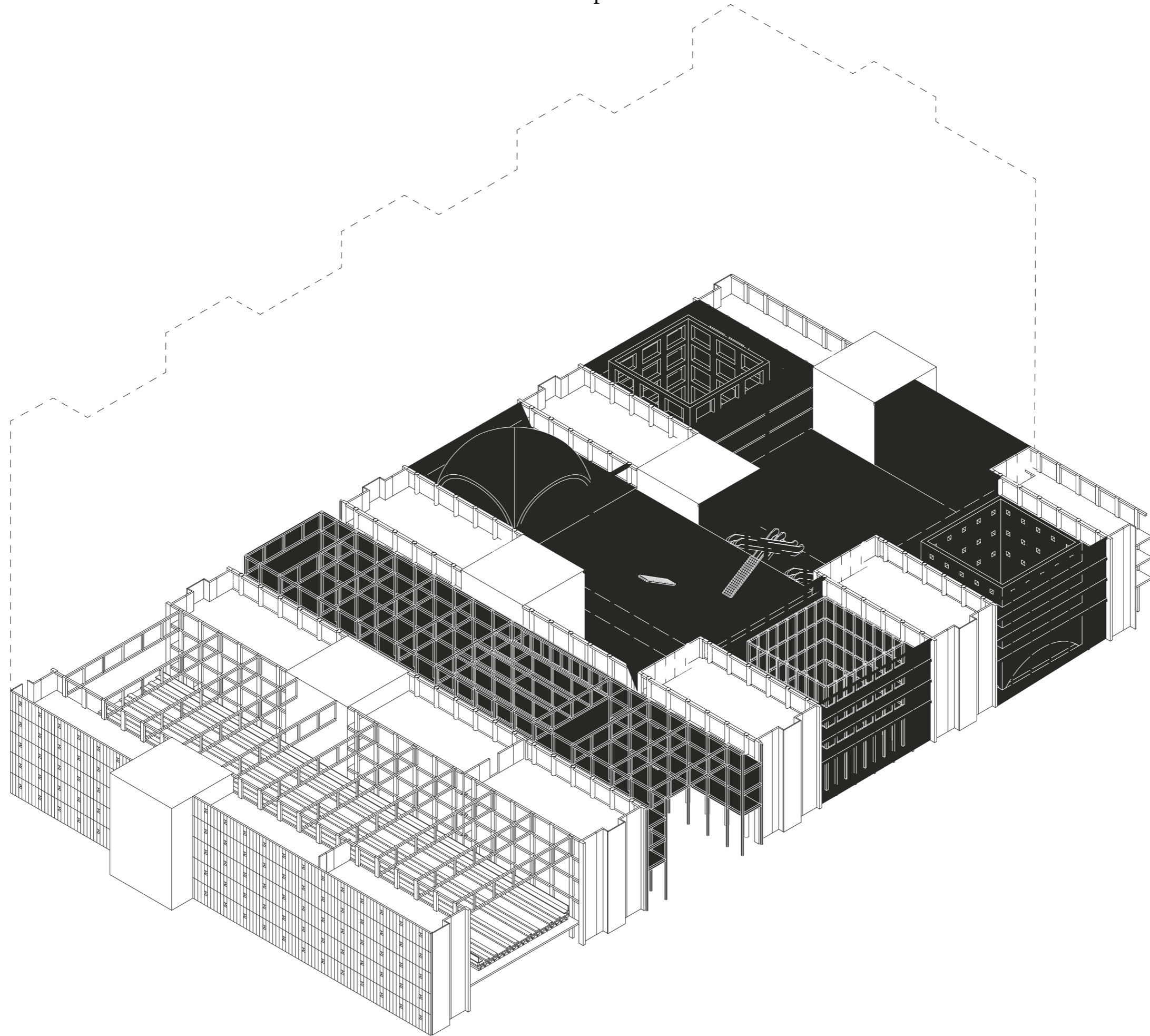

Ground floor plan

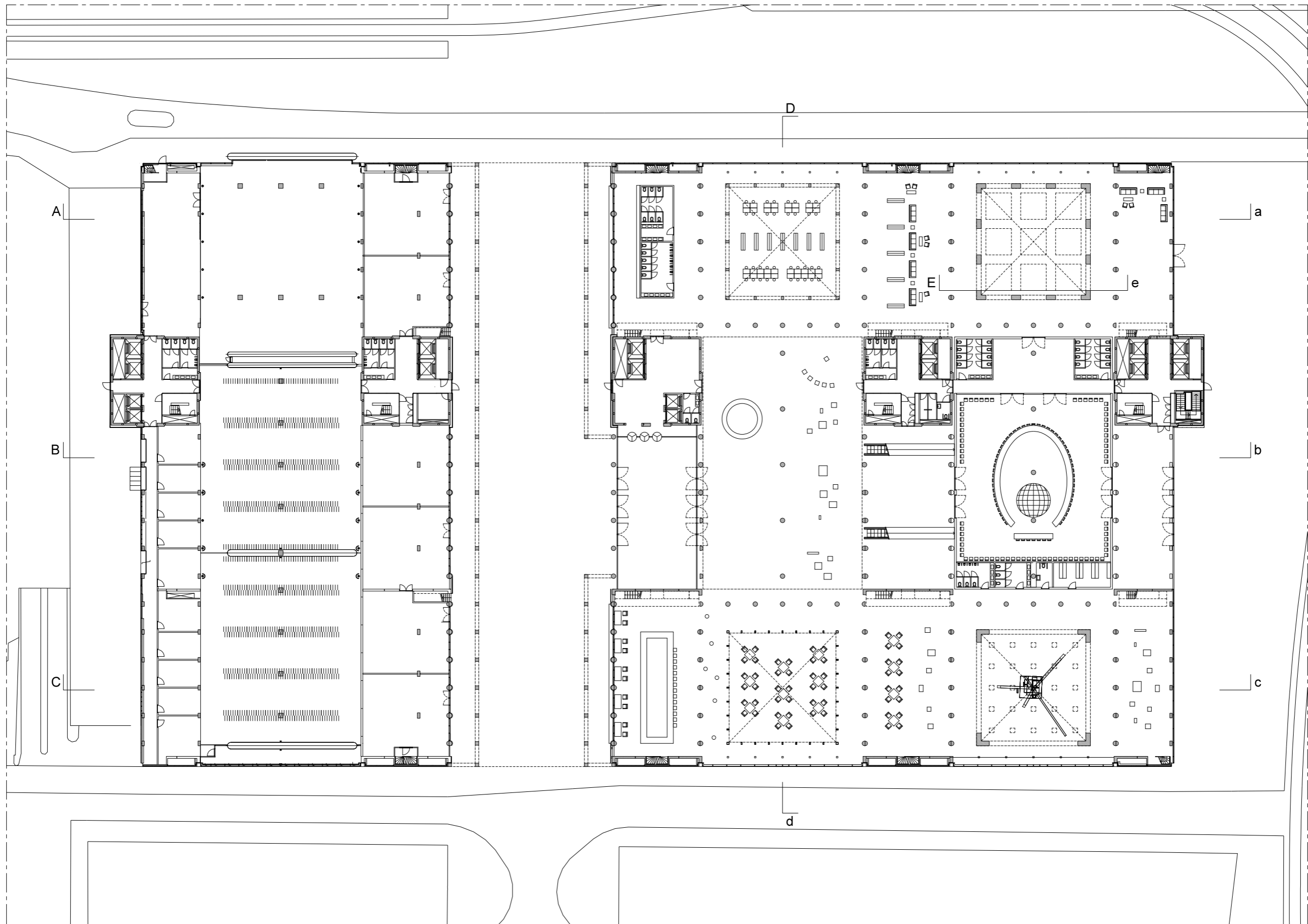

Ground floor plan

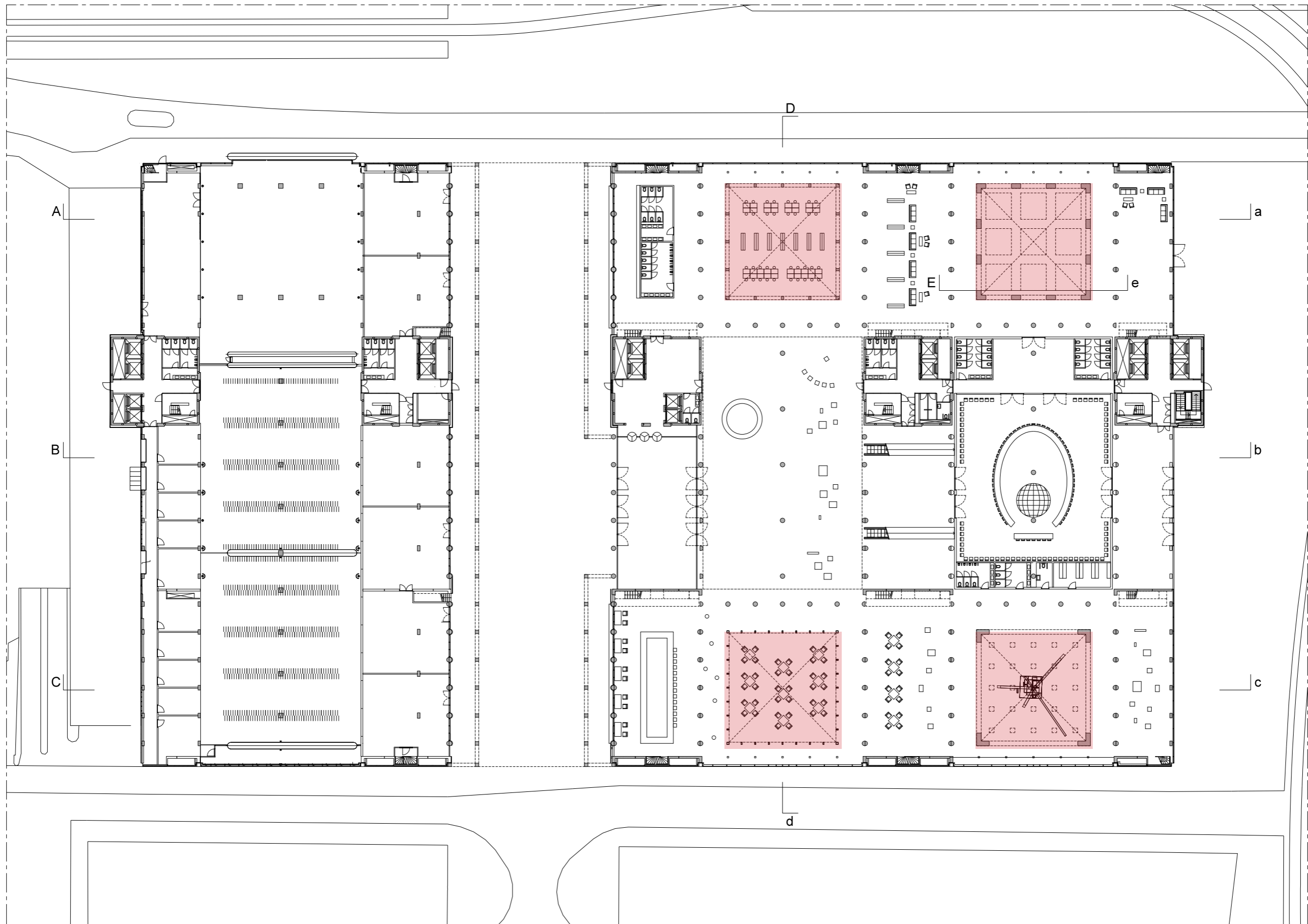

Ground floor plan

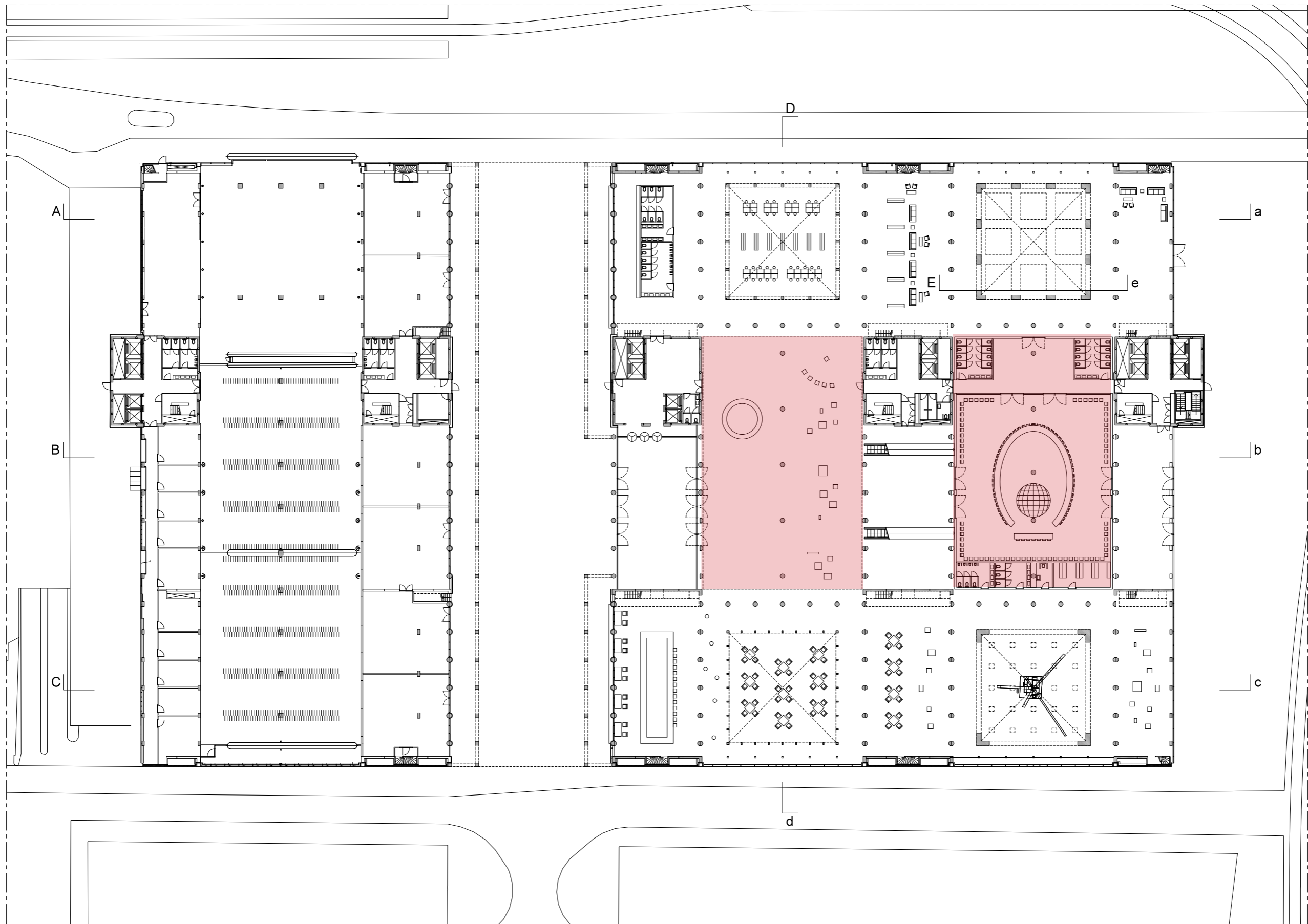

Ground floor plan

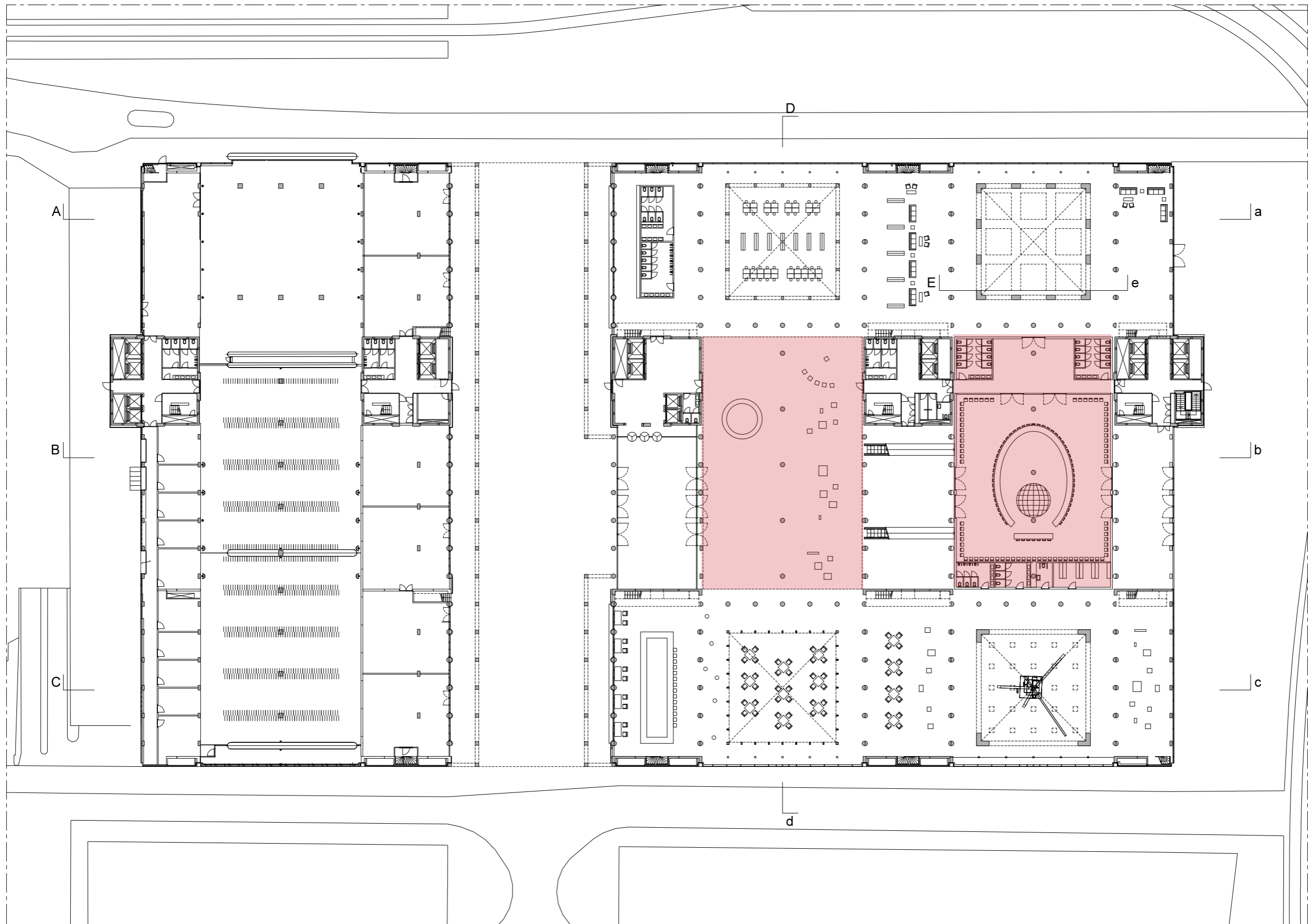

Routing

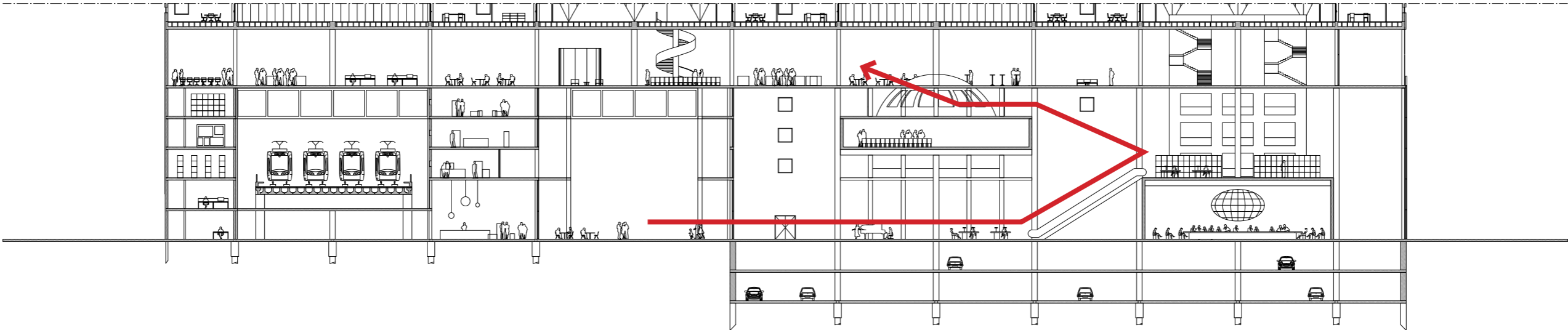
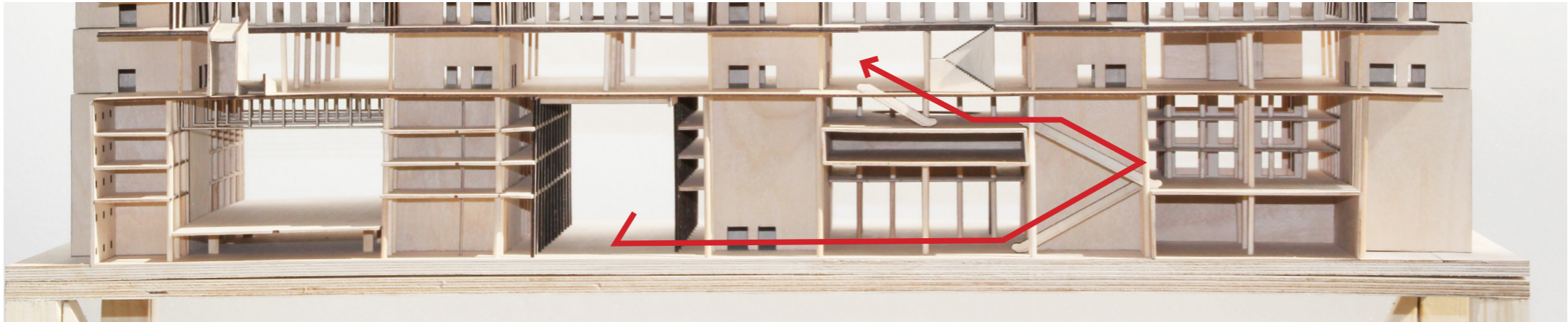

Section Bb

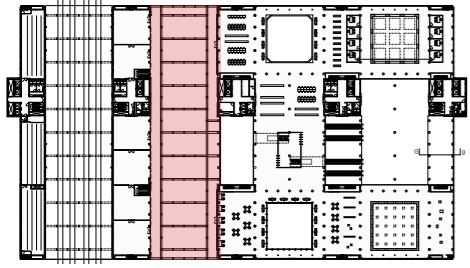

Ground floor plan

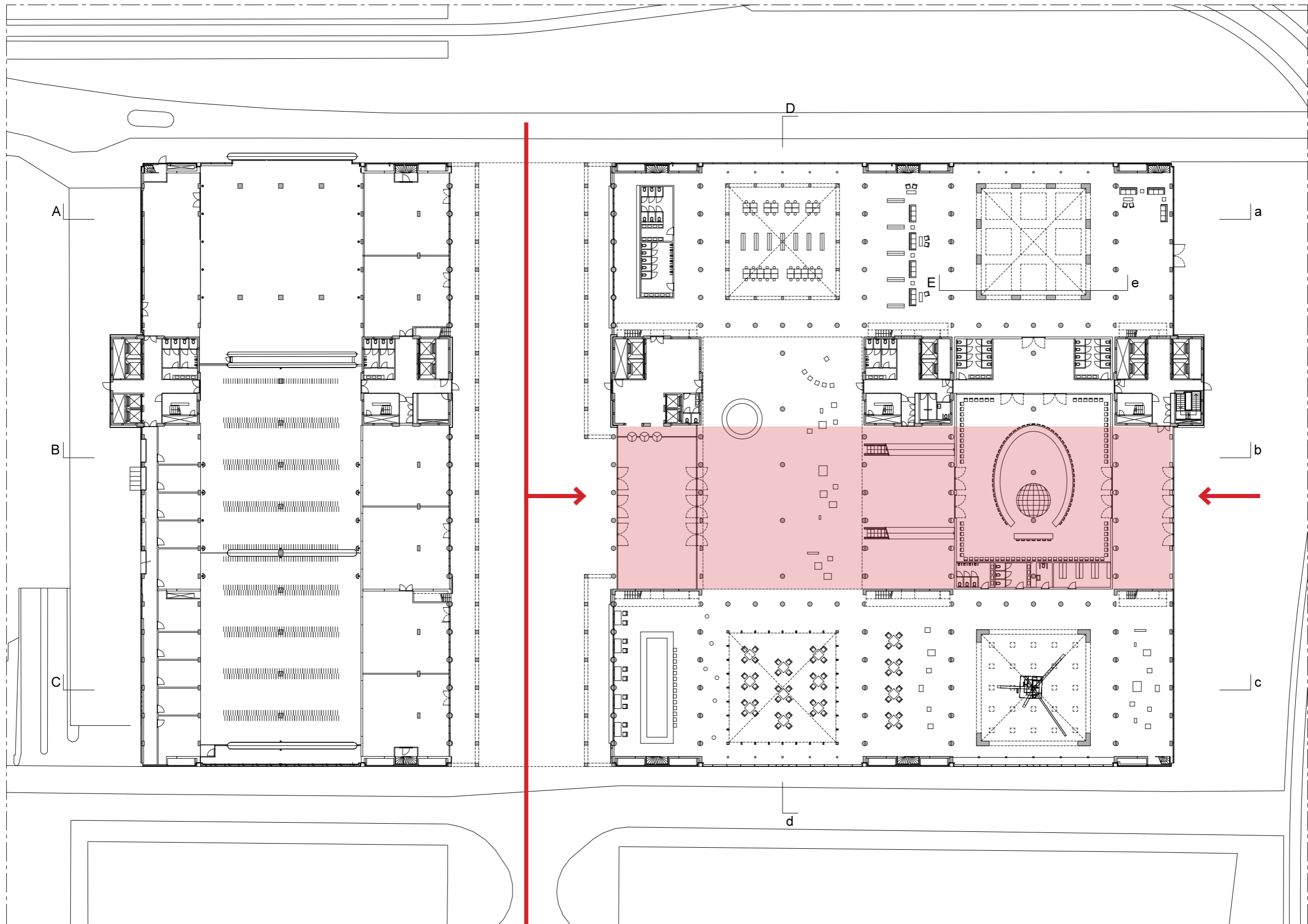

Second floor plan

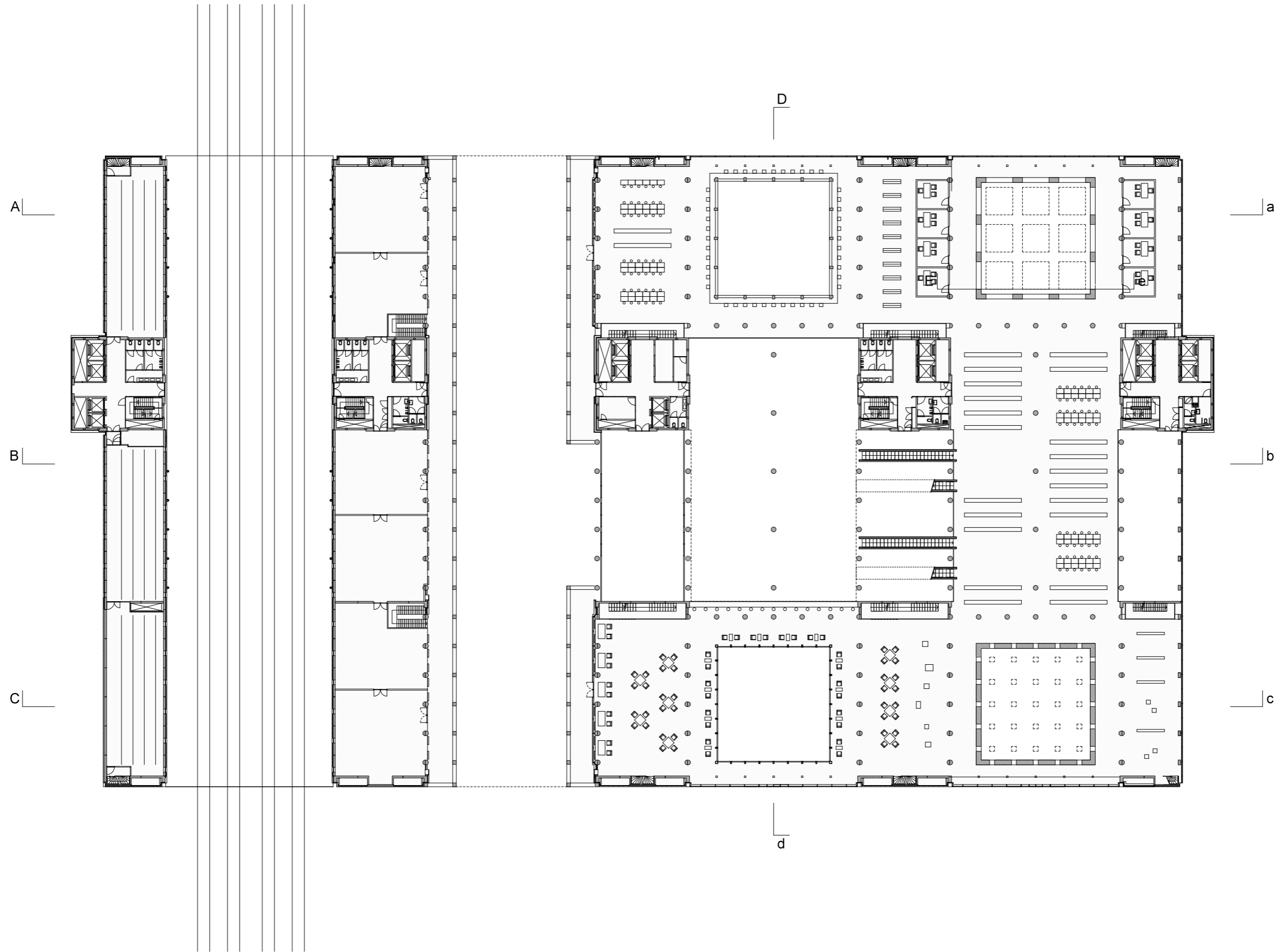

Fourth floor plan

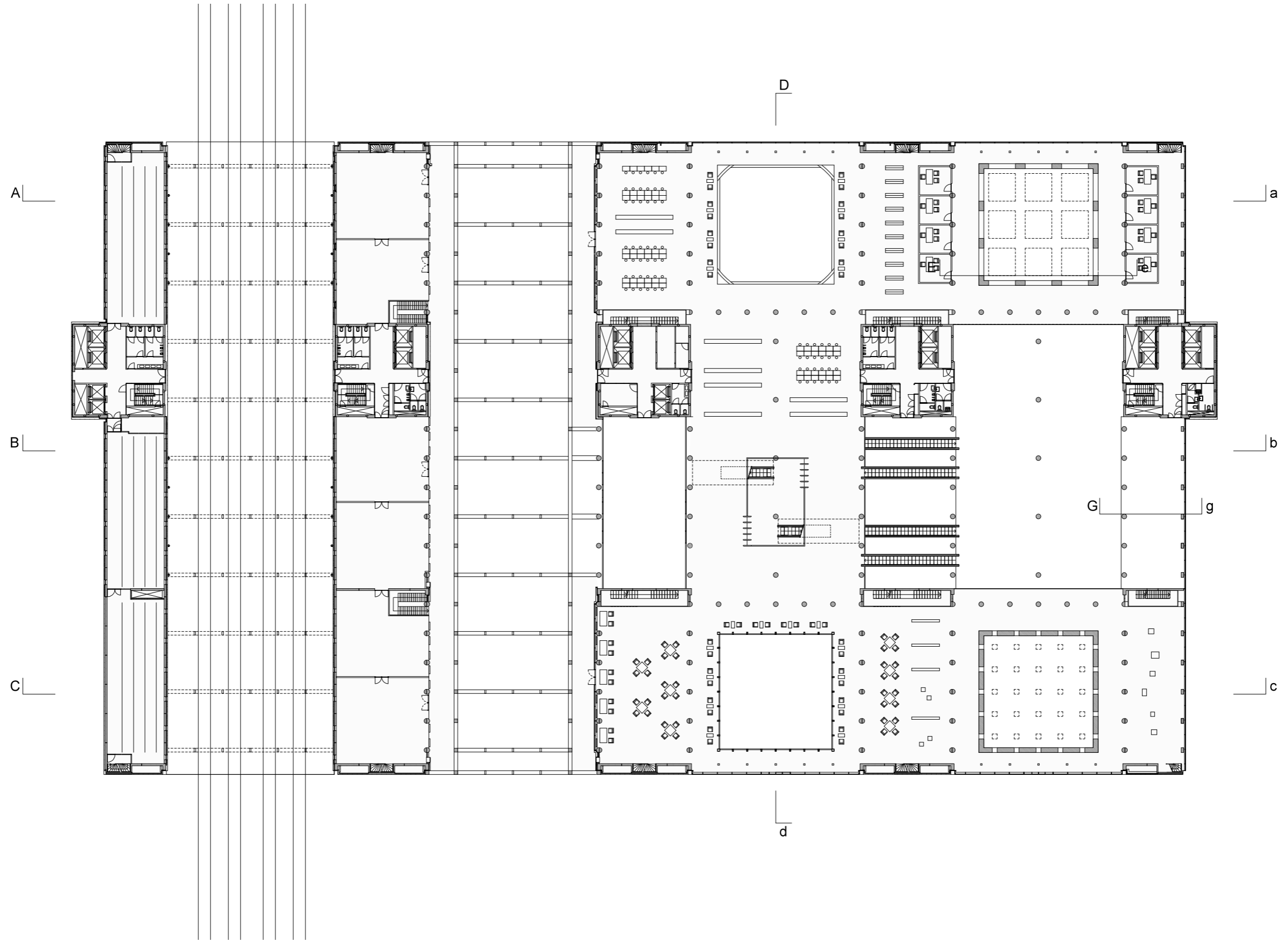

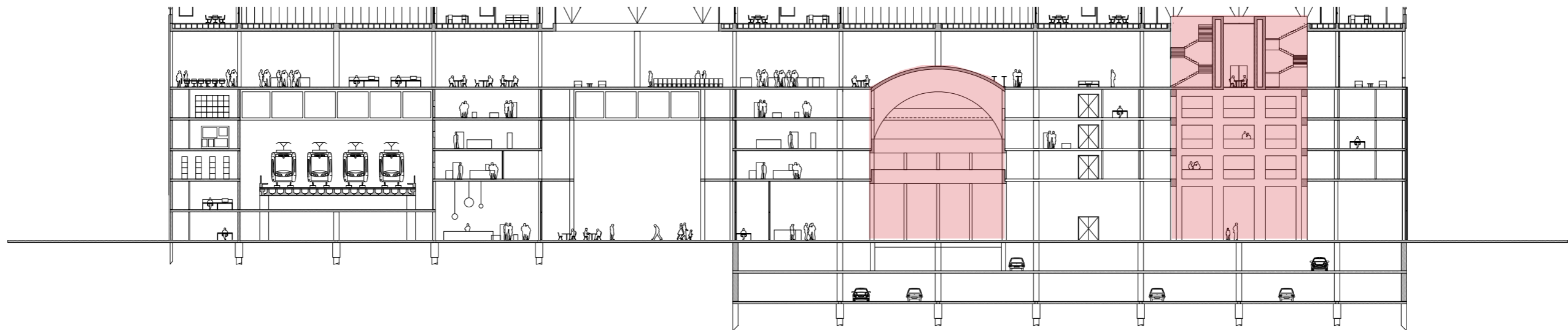

Section Aa

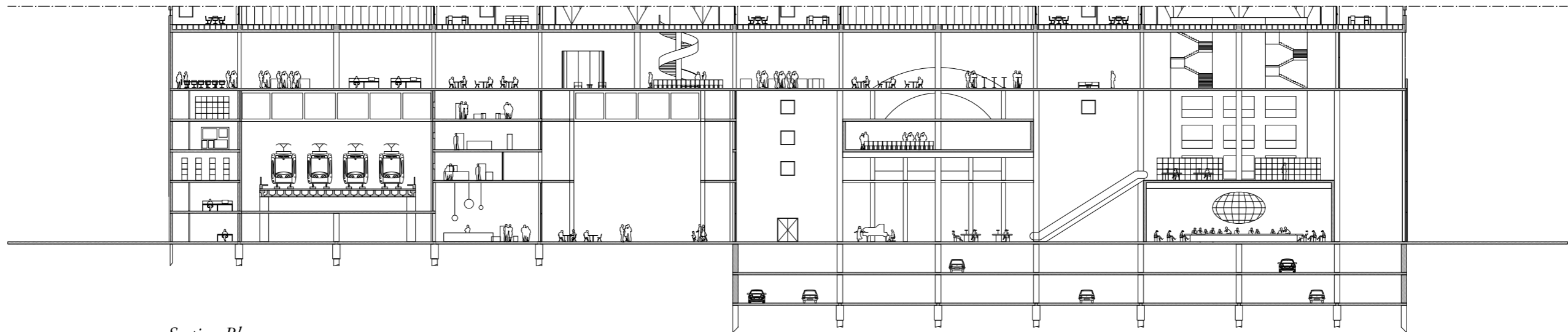

Section Bb

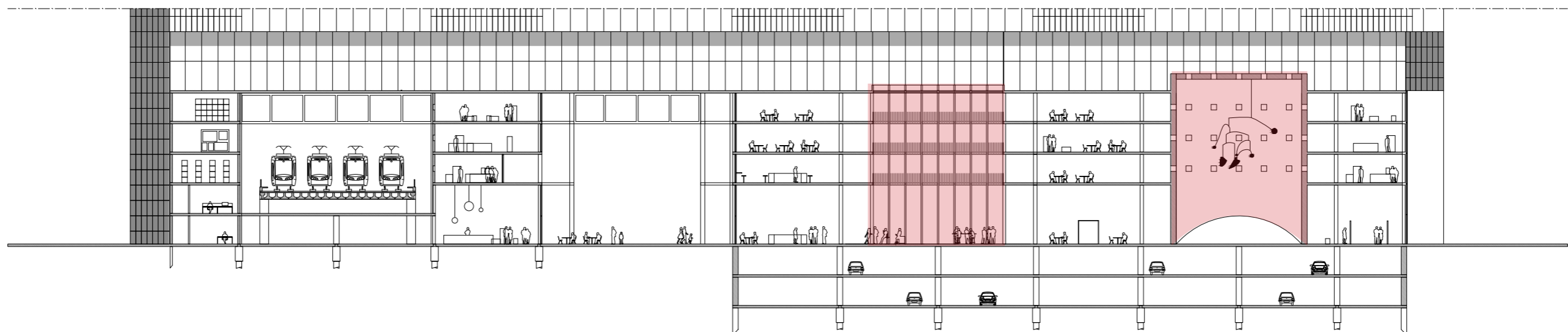

Section Cc

Exhibition room

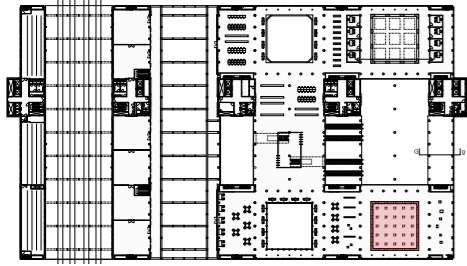

IND hall

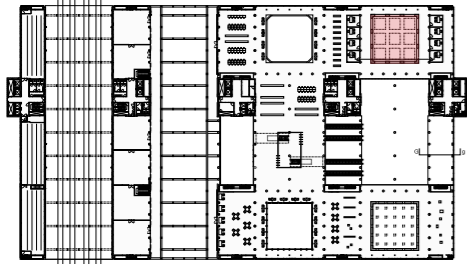

Detailed section

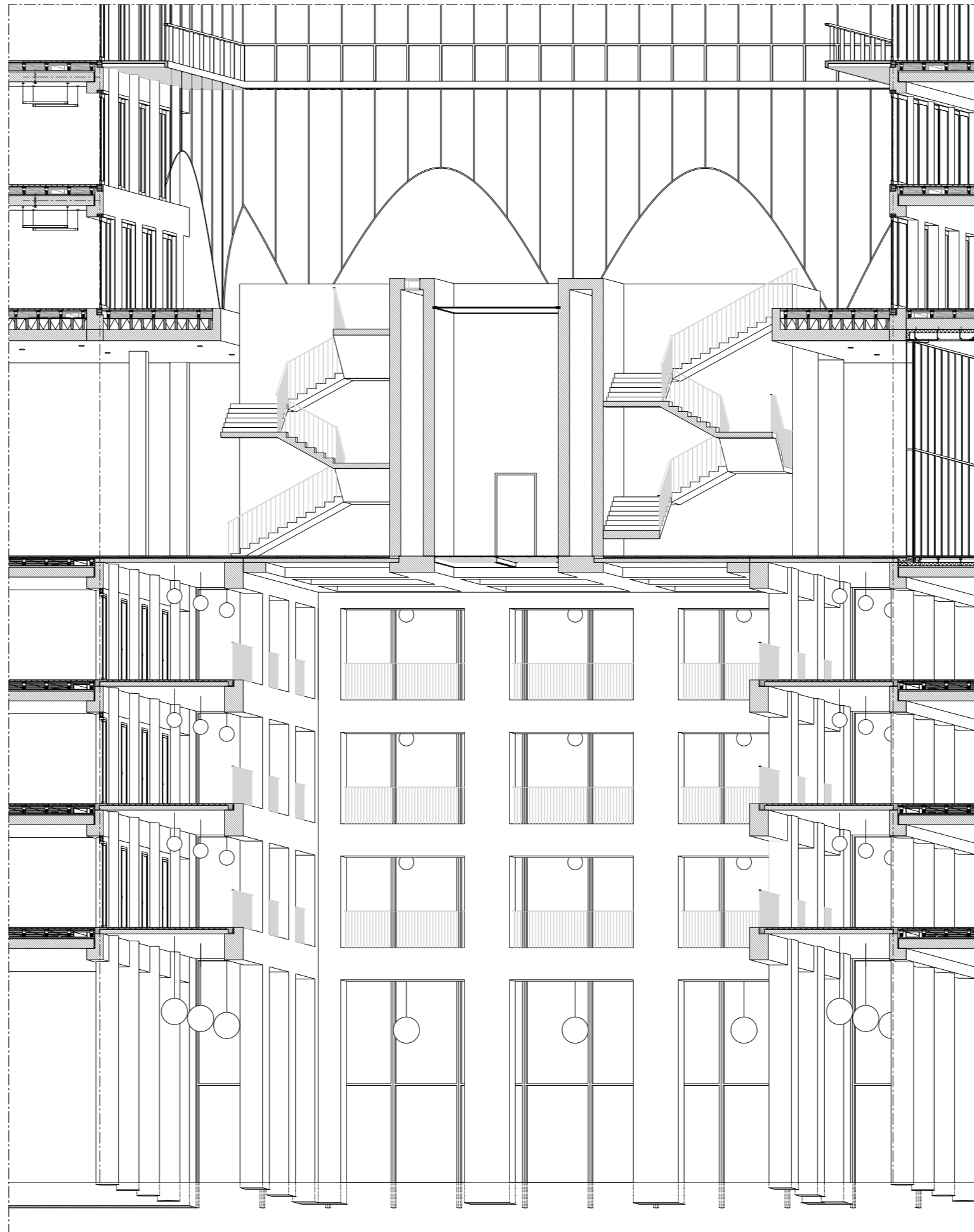

Section Ee

Close-up of detailed section



Section Ee

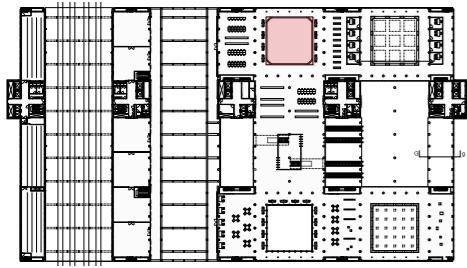







Design Proposal
Meeting

Meeting

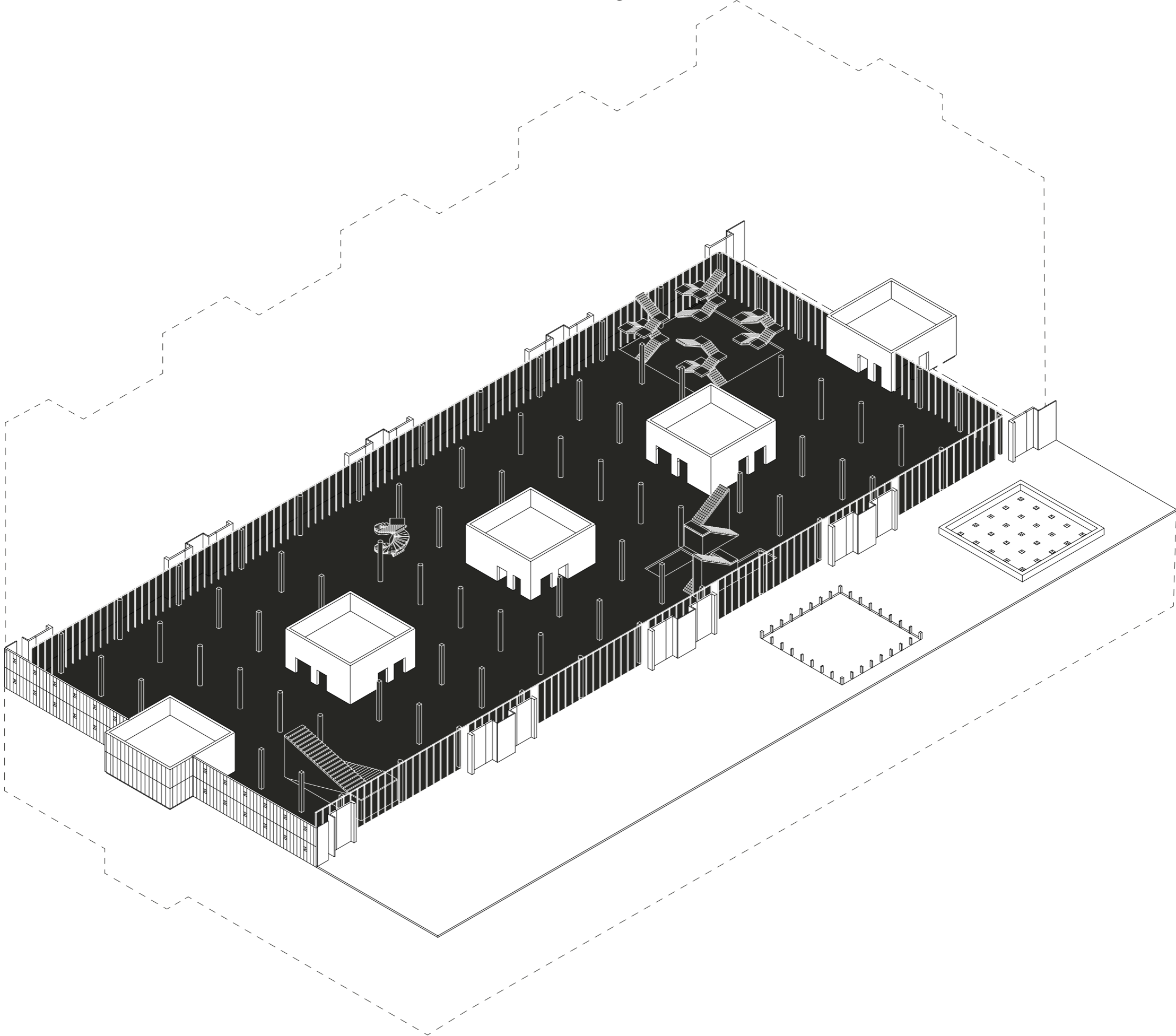

Longitudinal section

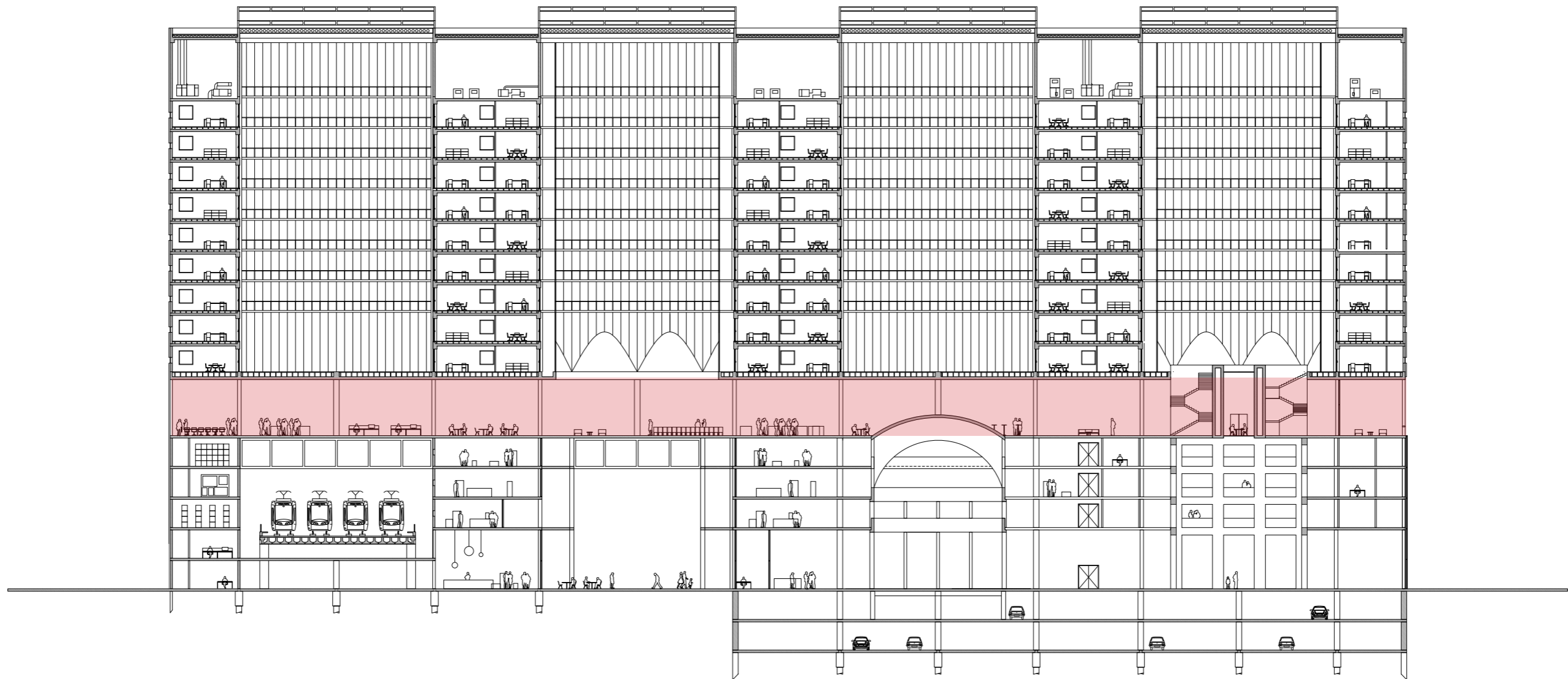

Section Aa

Fifth floor plan

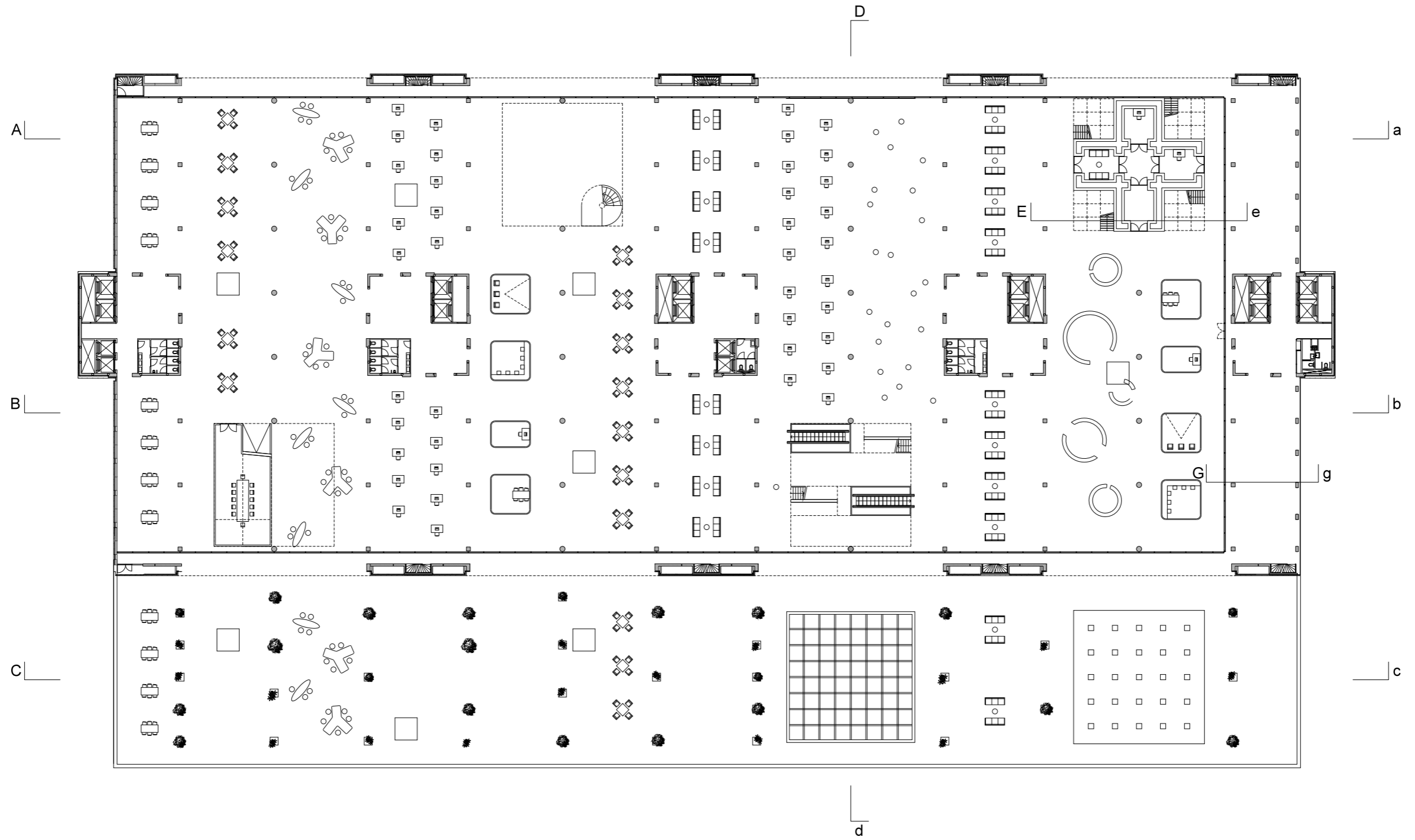

Fifth floor plan

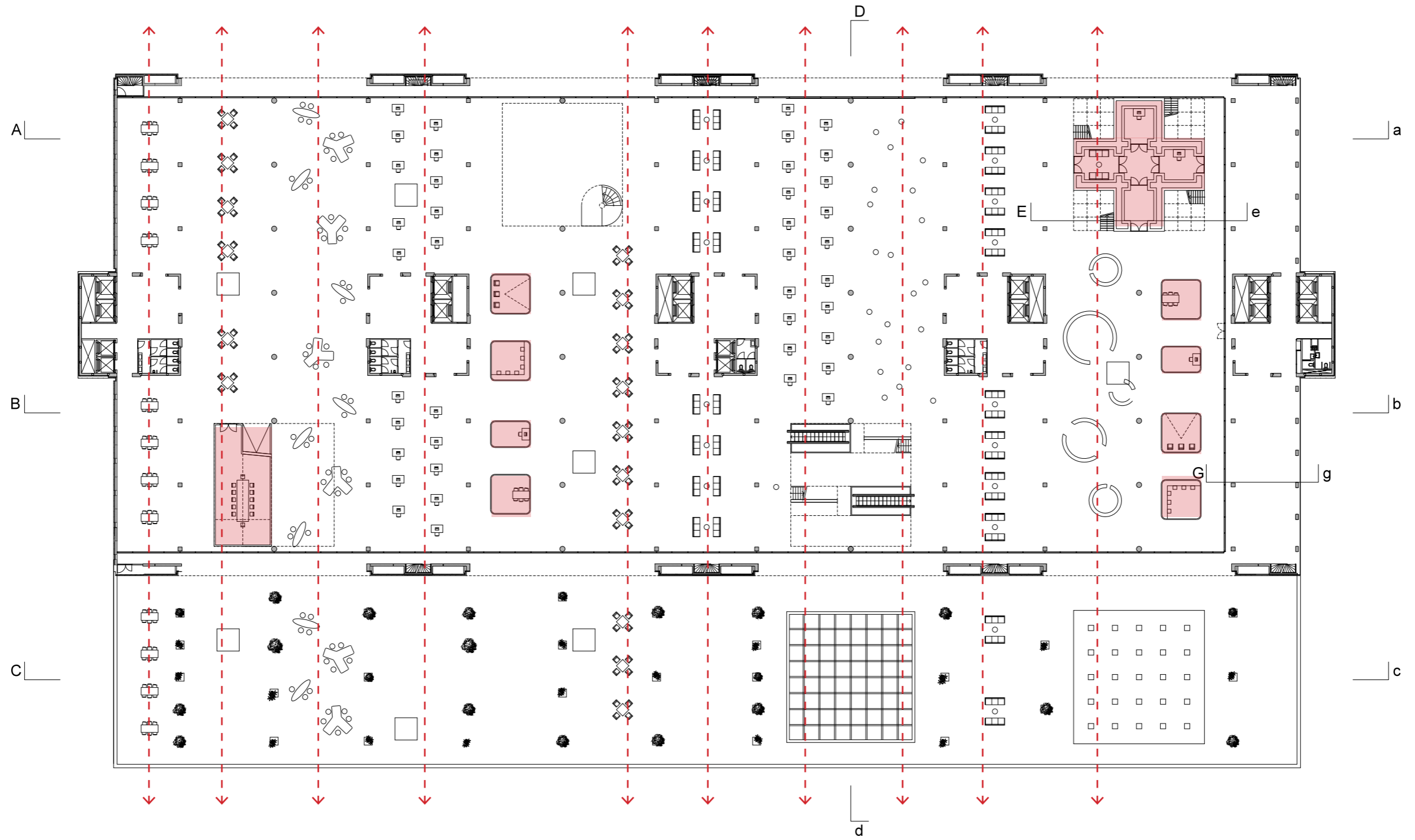

Fifth floor model

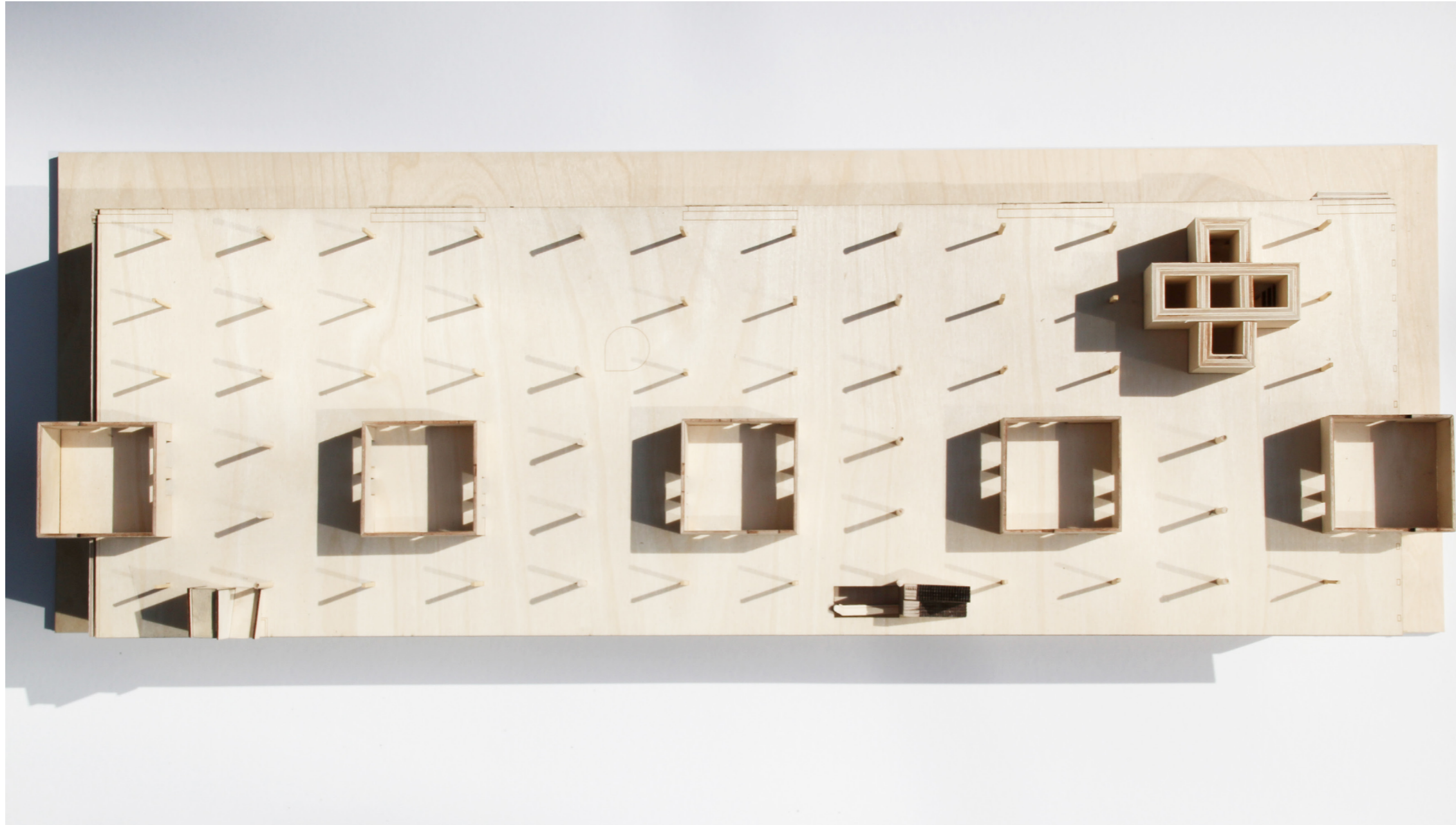

Fifth floor construction

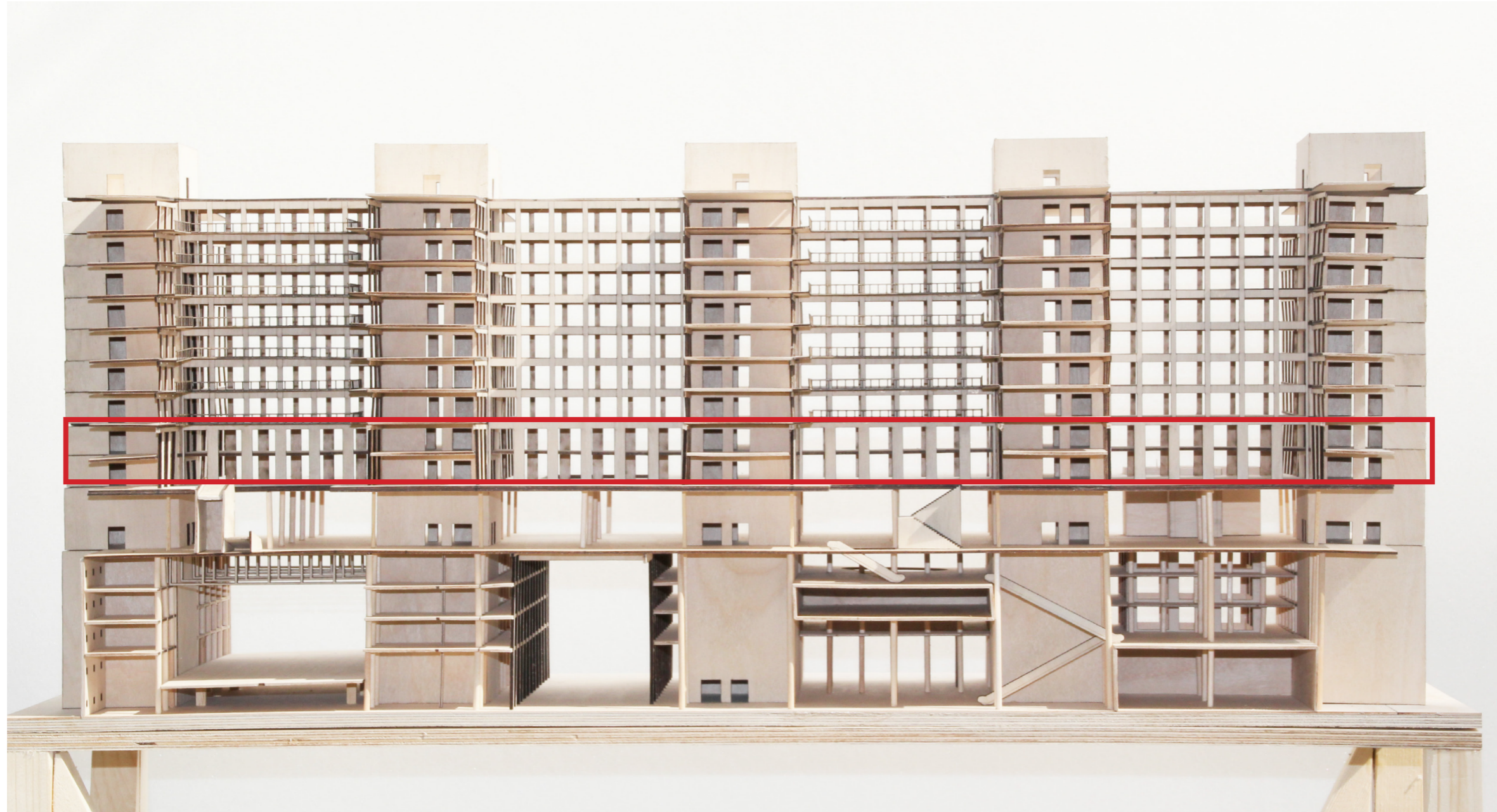

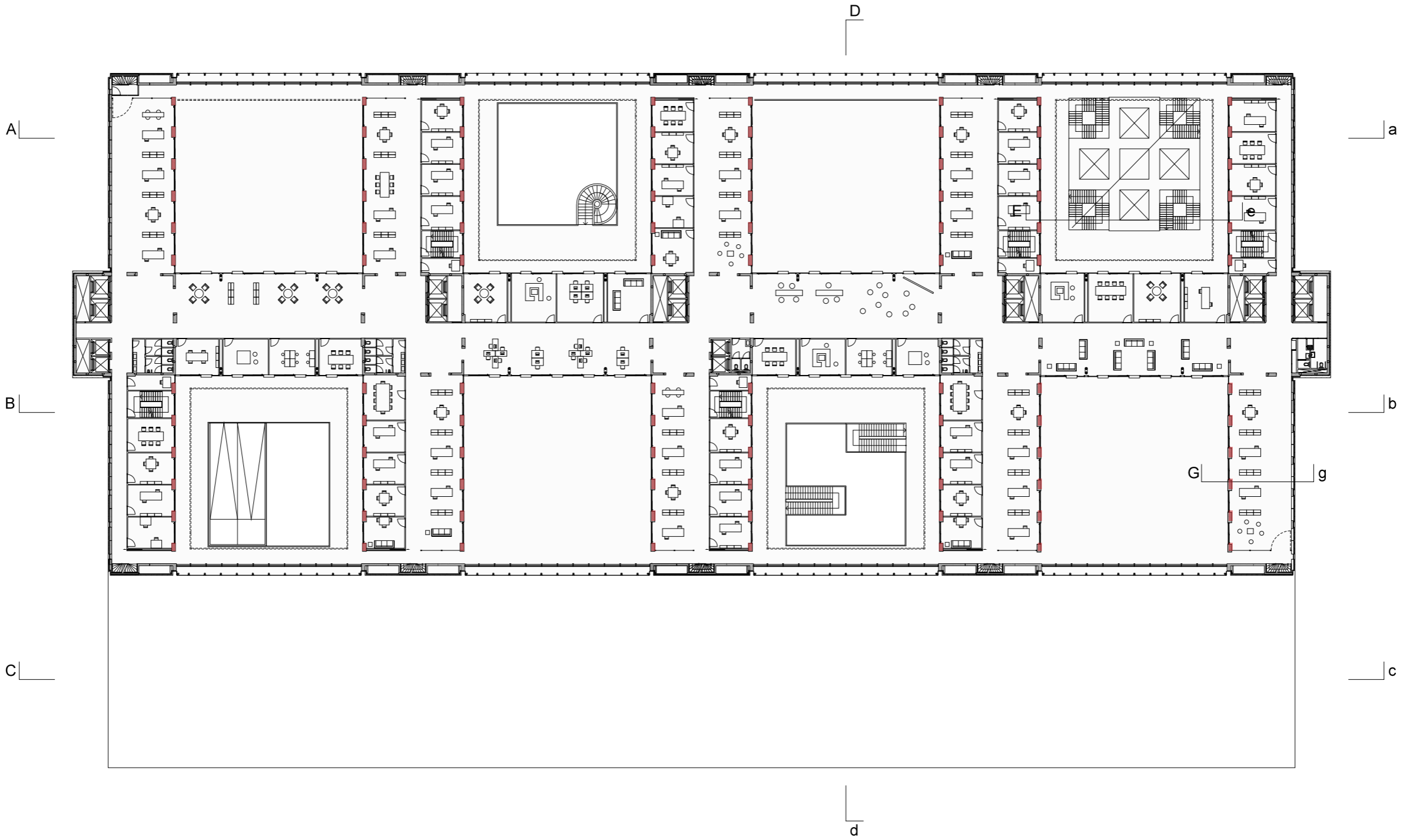

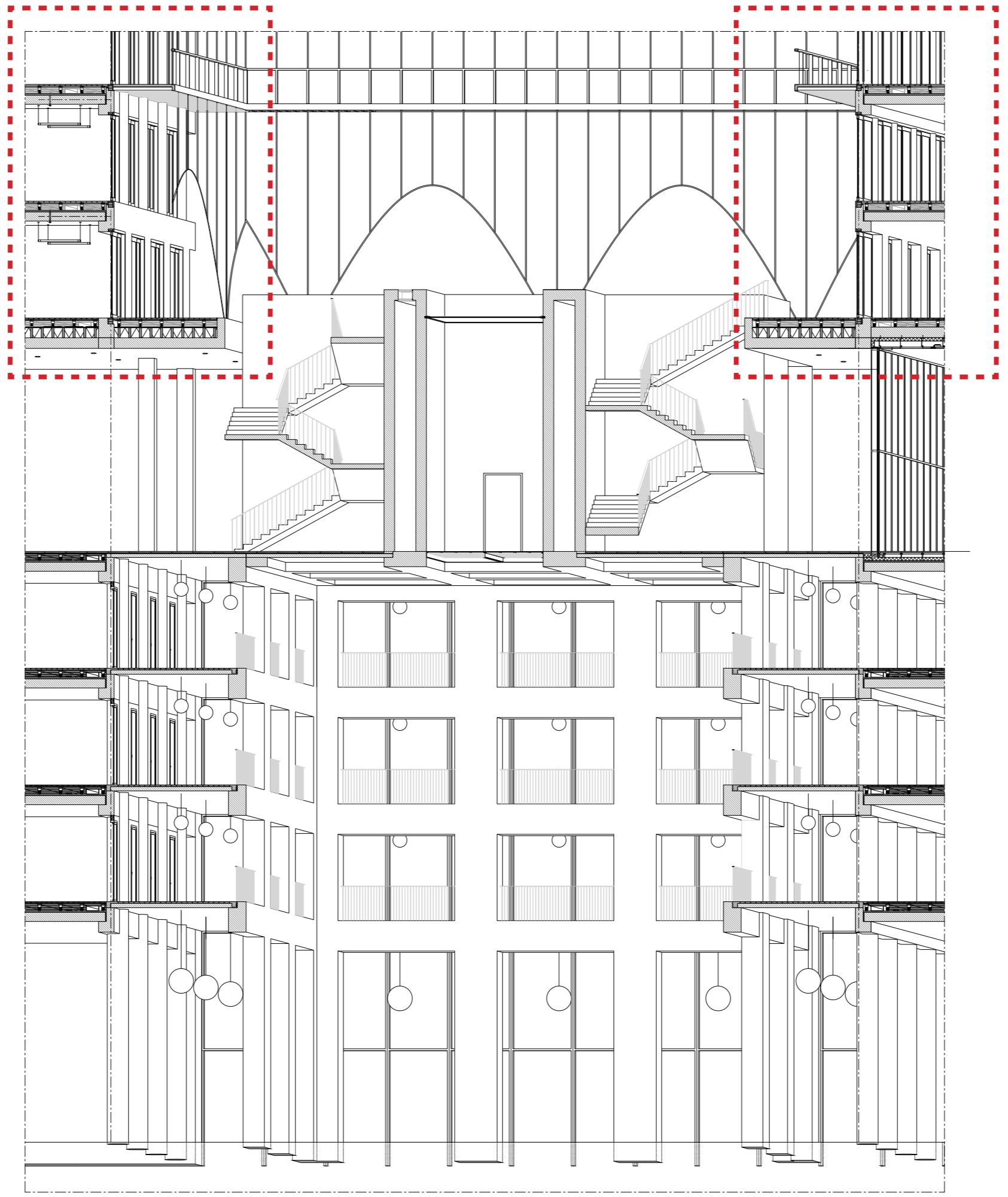

Meeting floor



Meeting floor

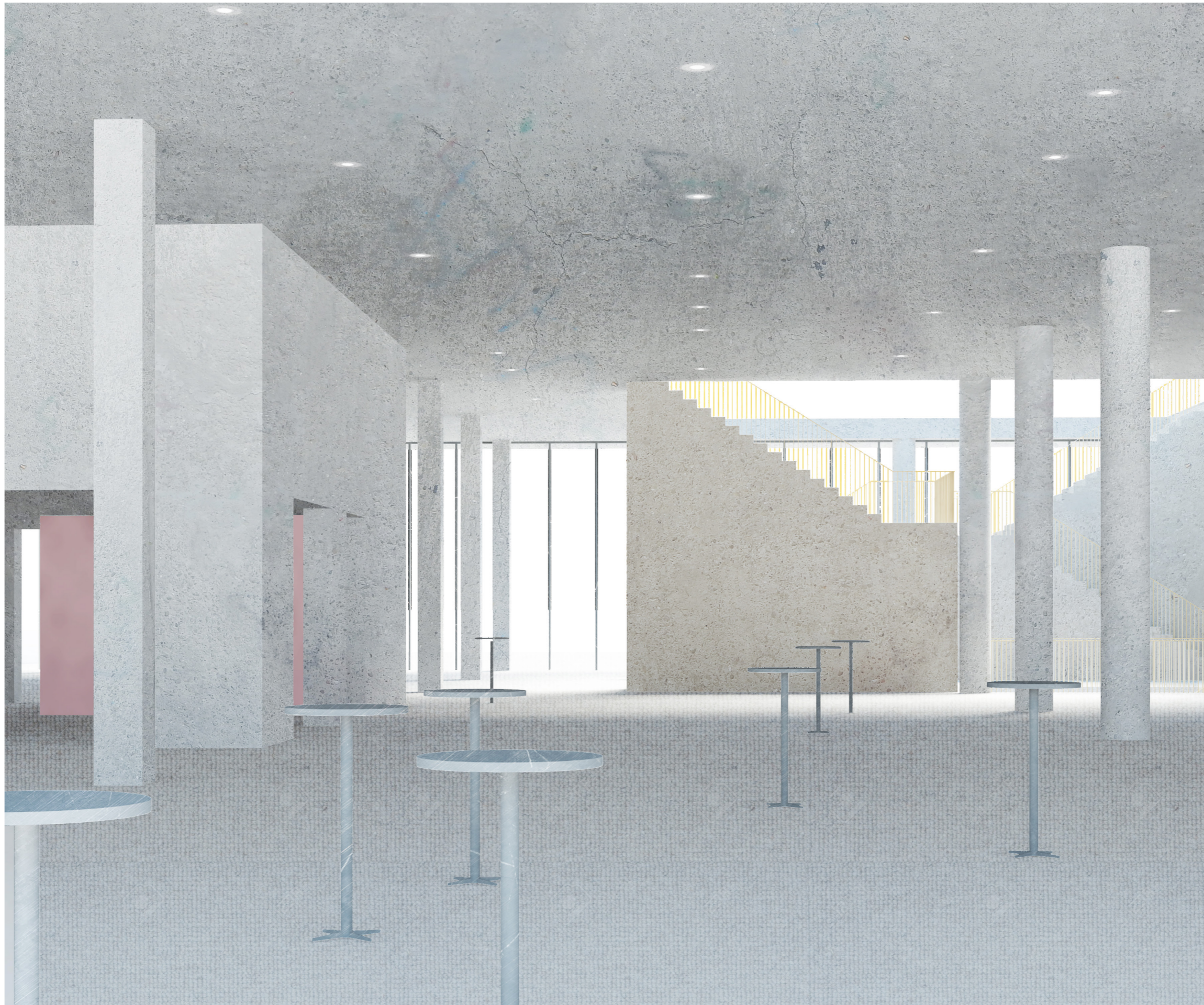

Meeting floor



Detailed section of the facade

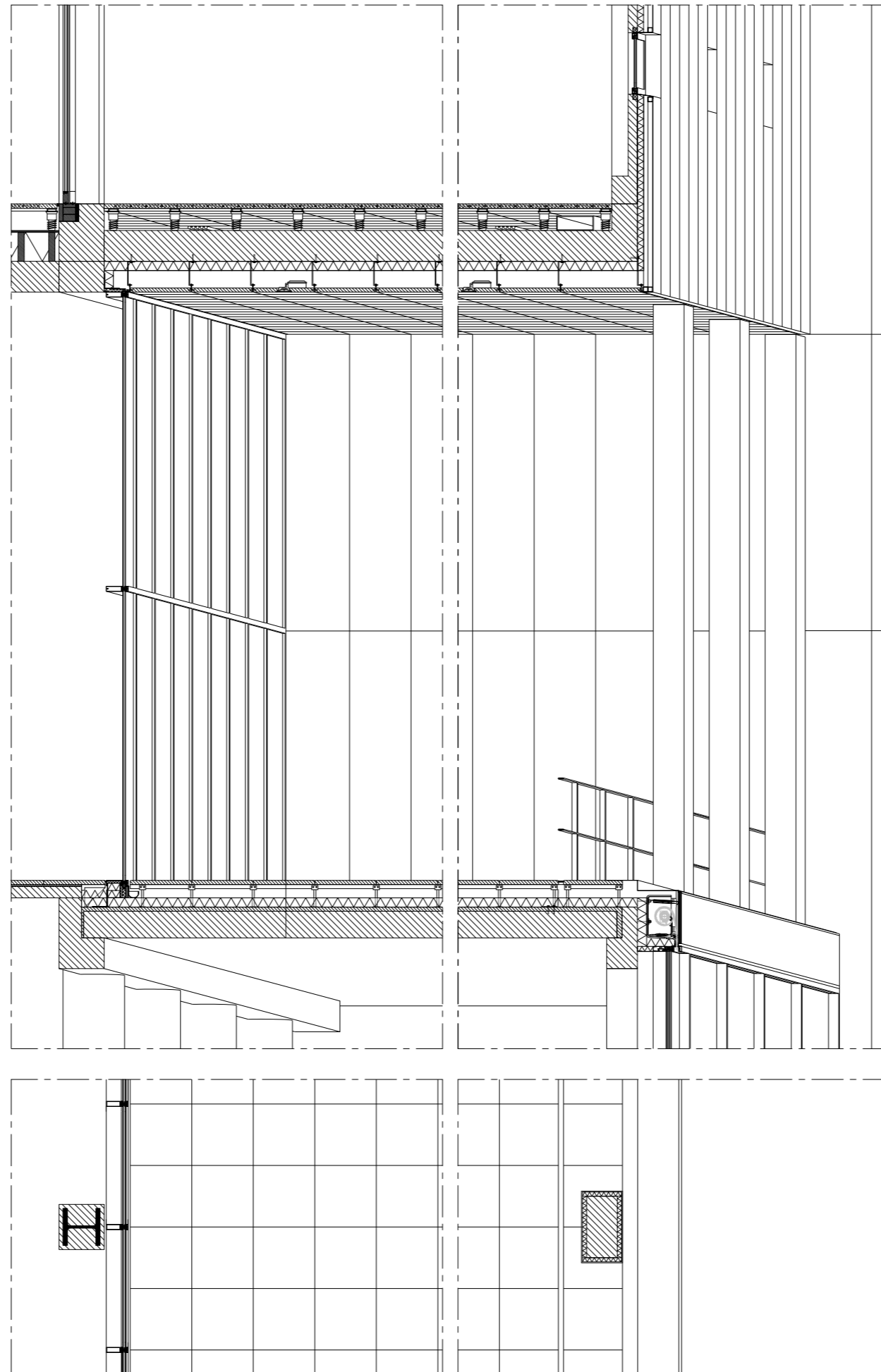

Section Gg

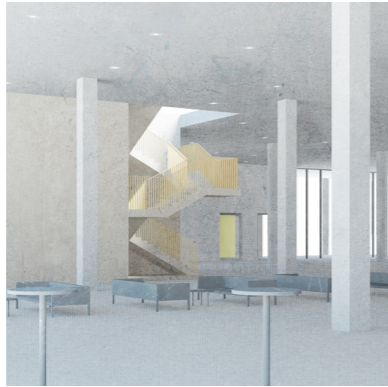

Design Proposal
Working

Working

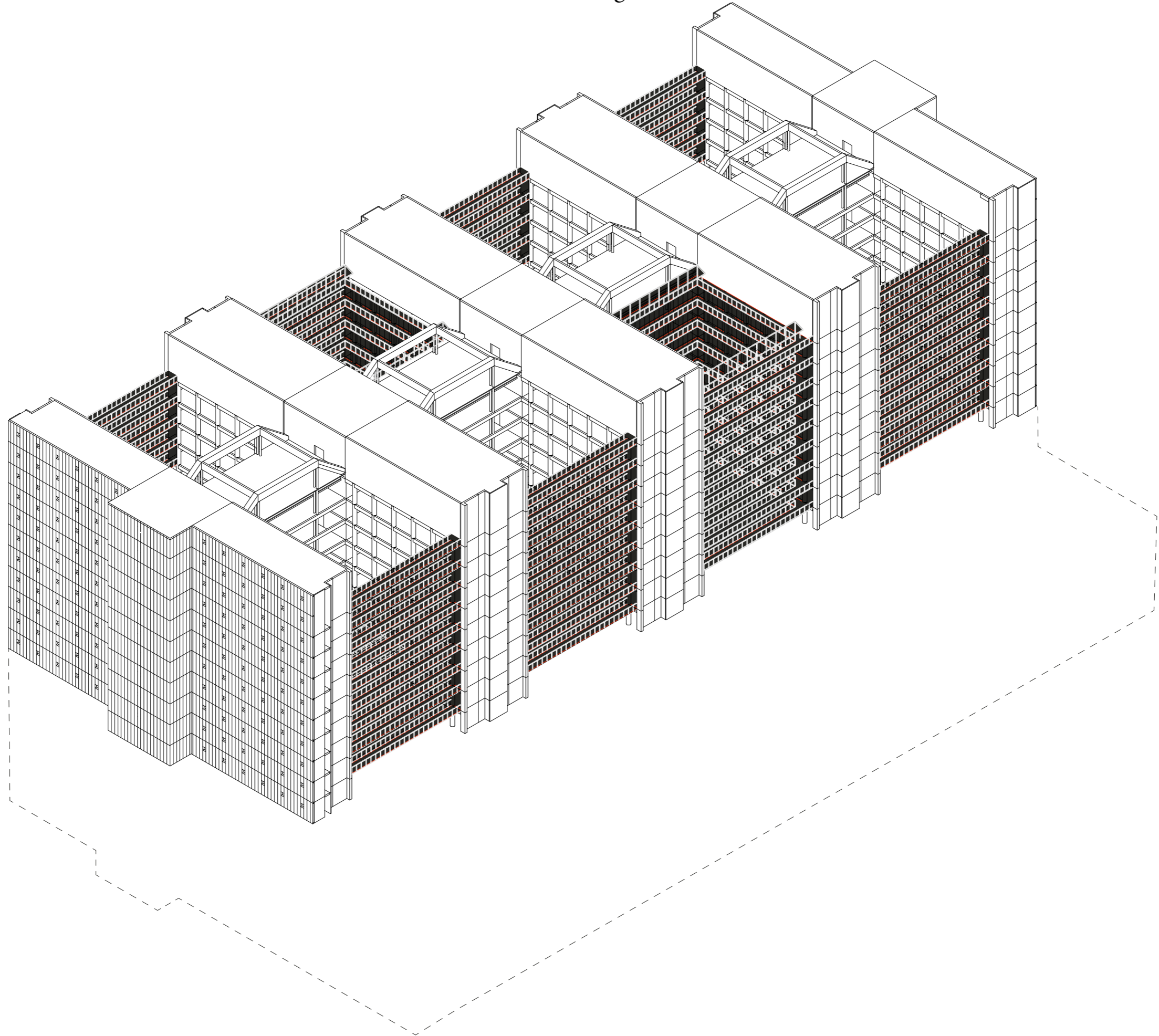

Seventh floor plan

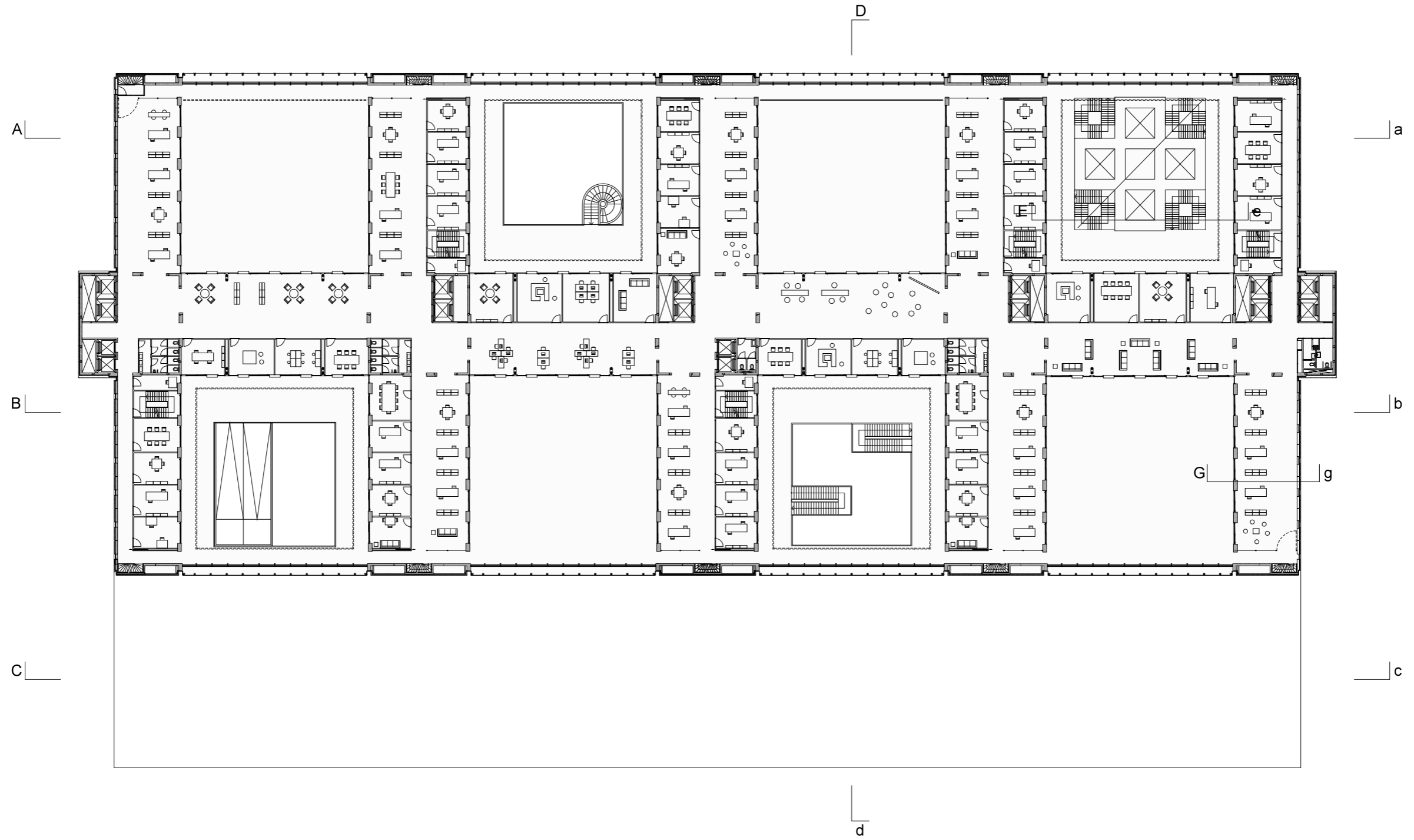

11th floor plan

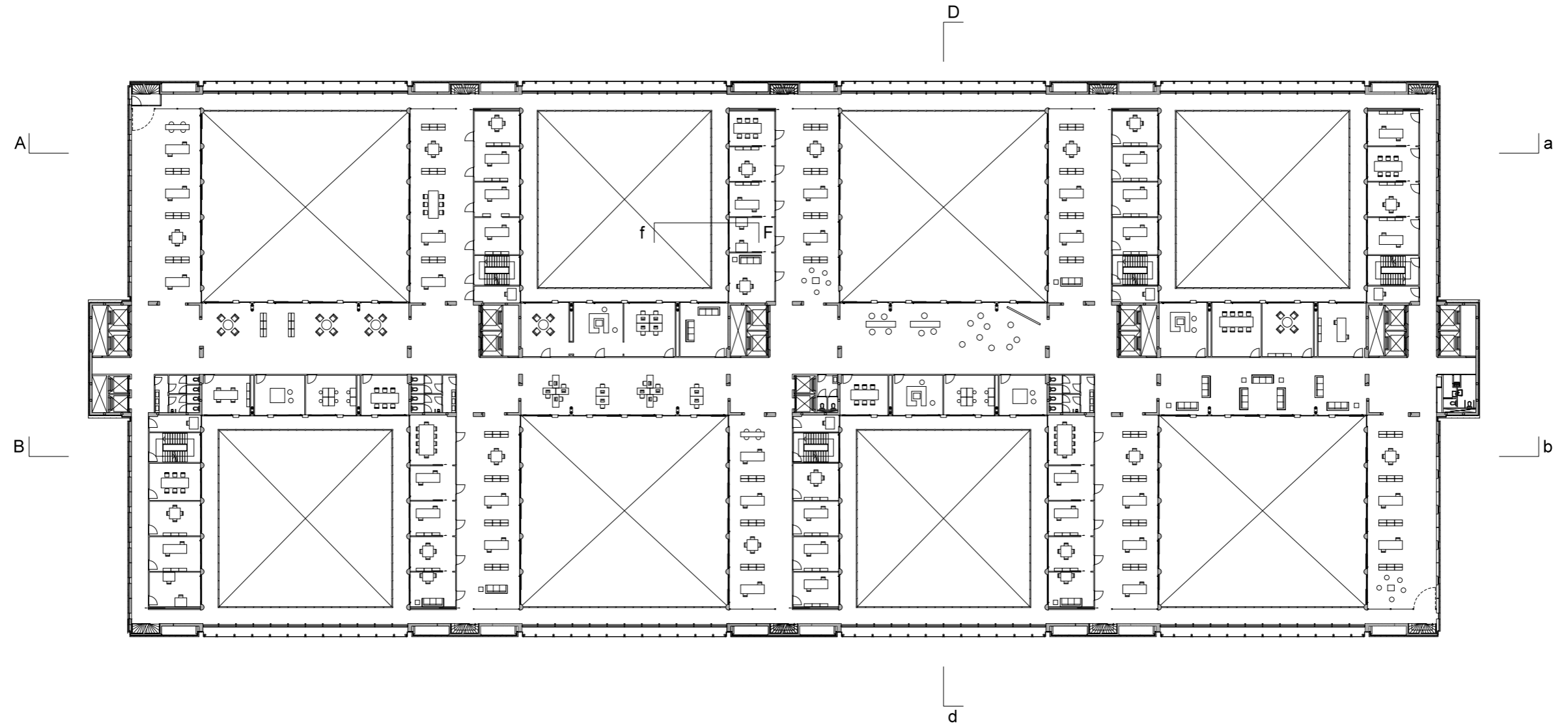

11th floor plan

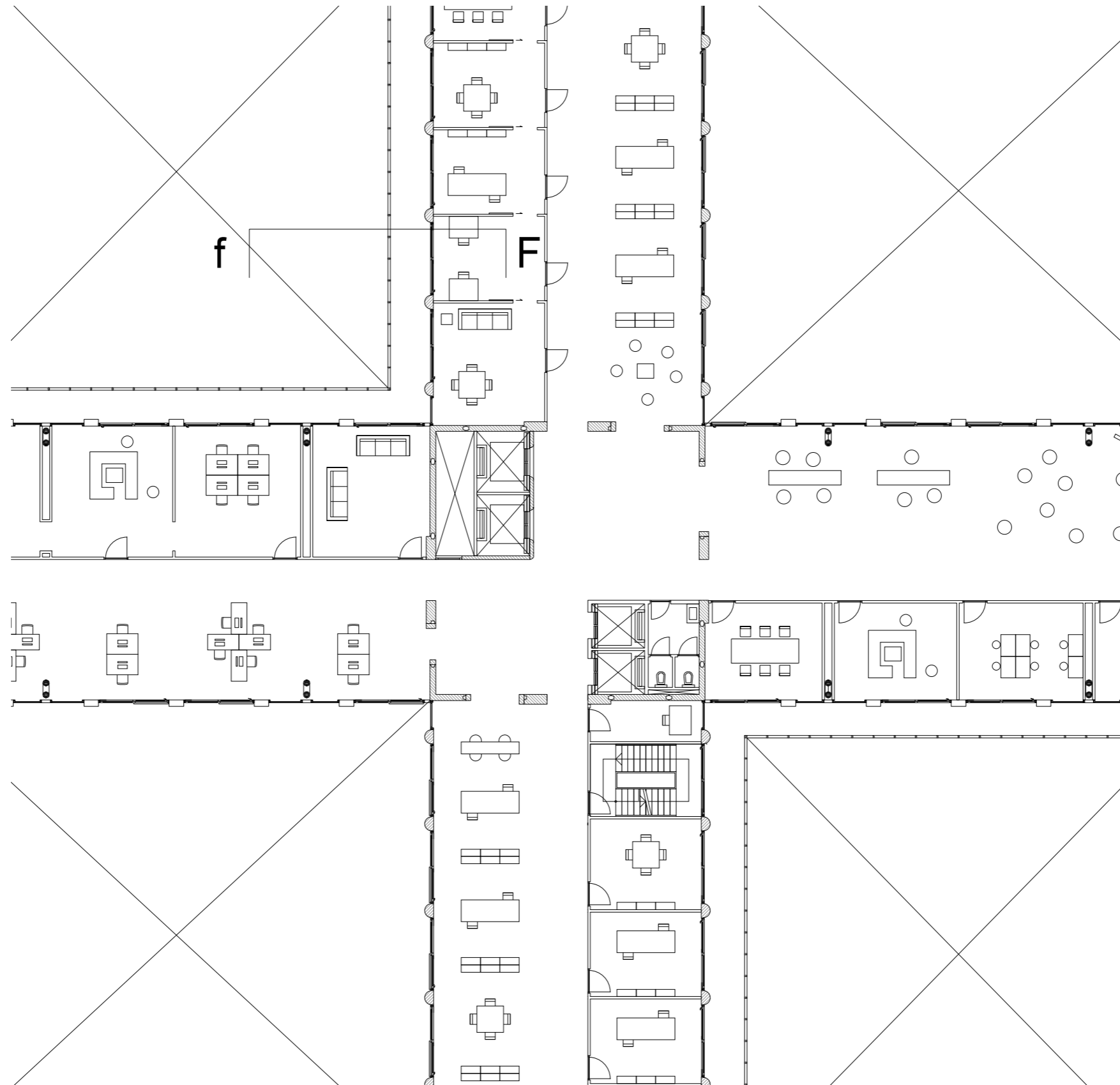



14th floor plan

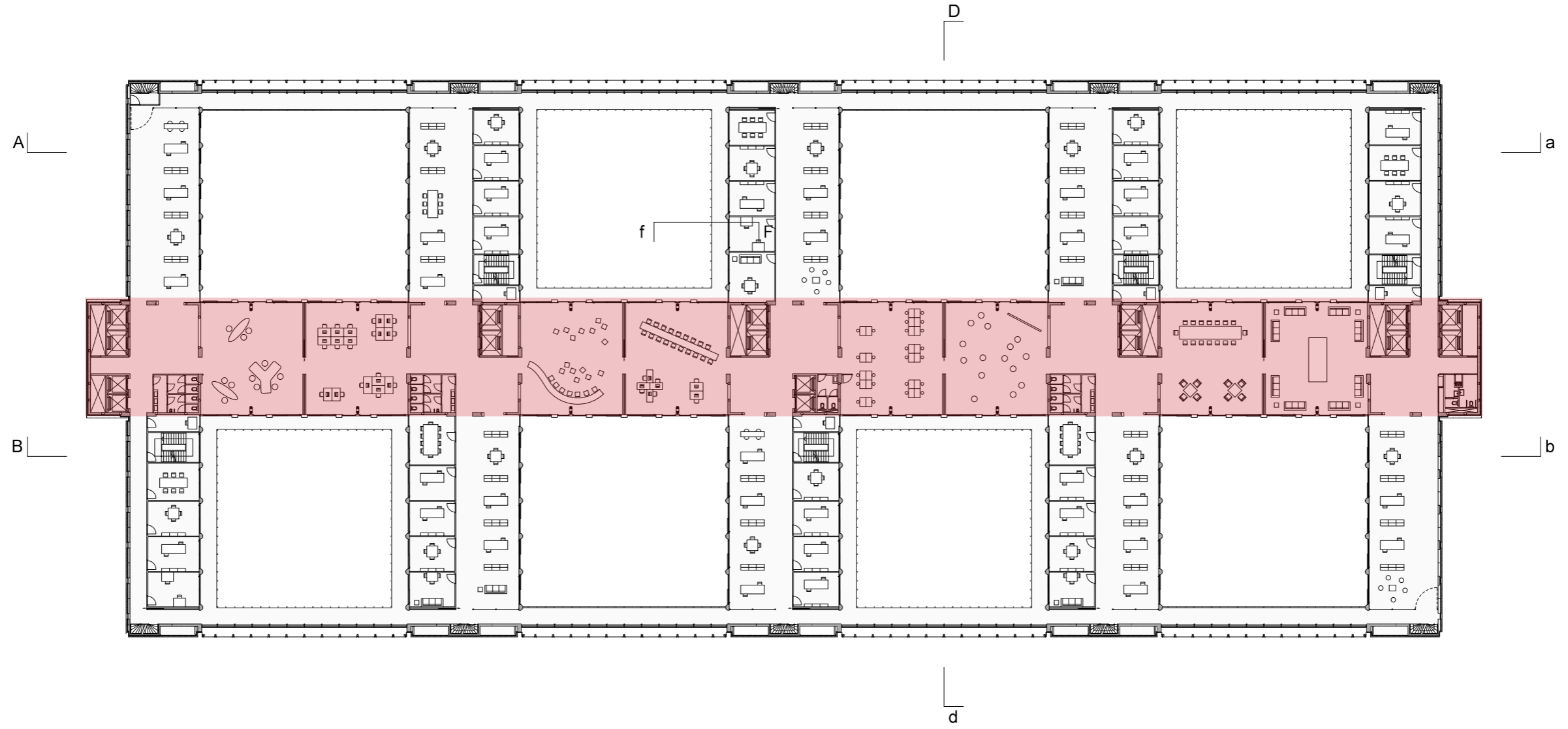

“Living room” workspace image

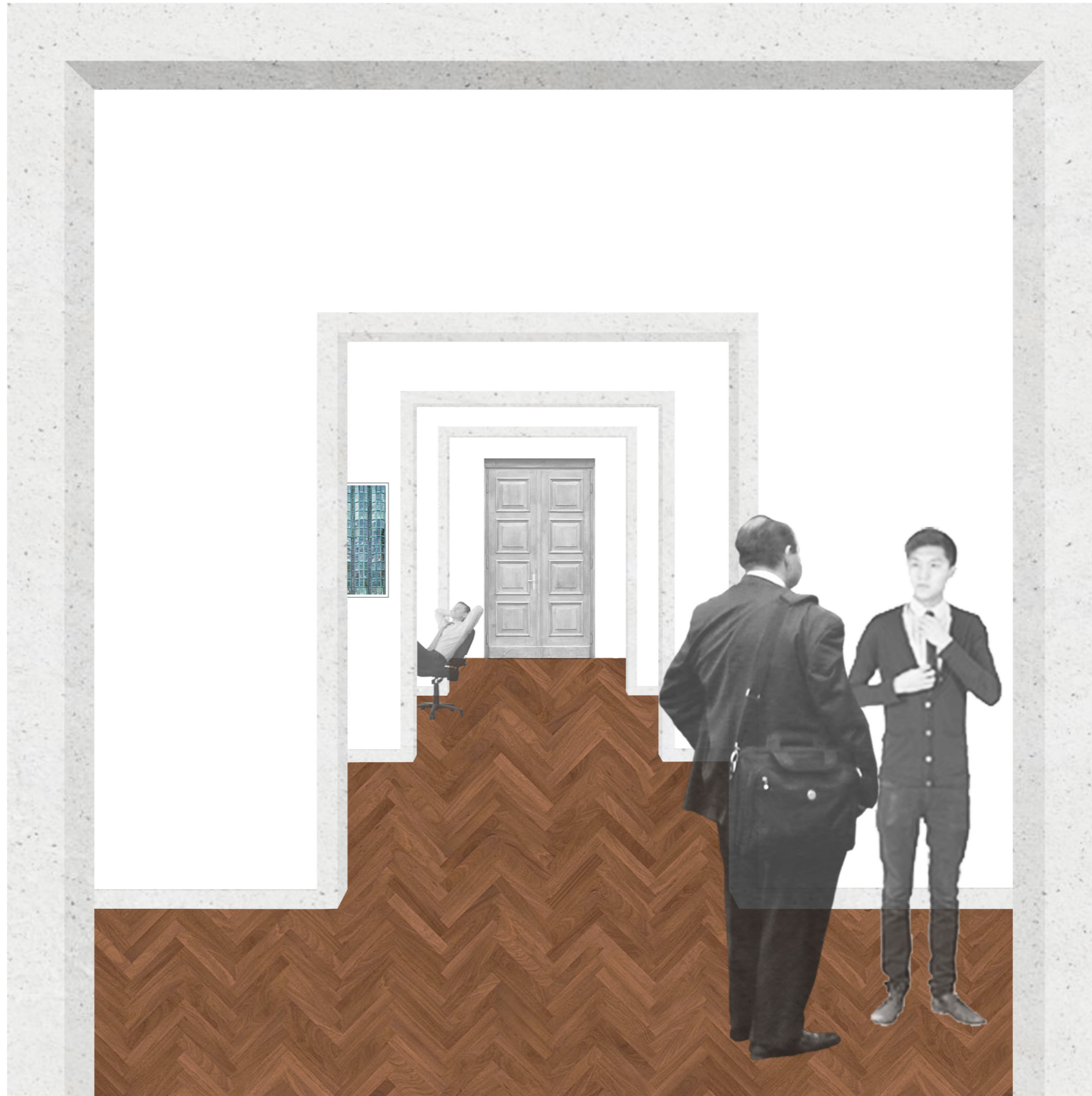

11th floor plan

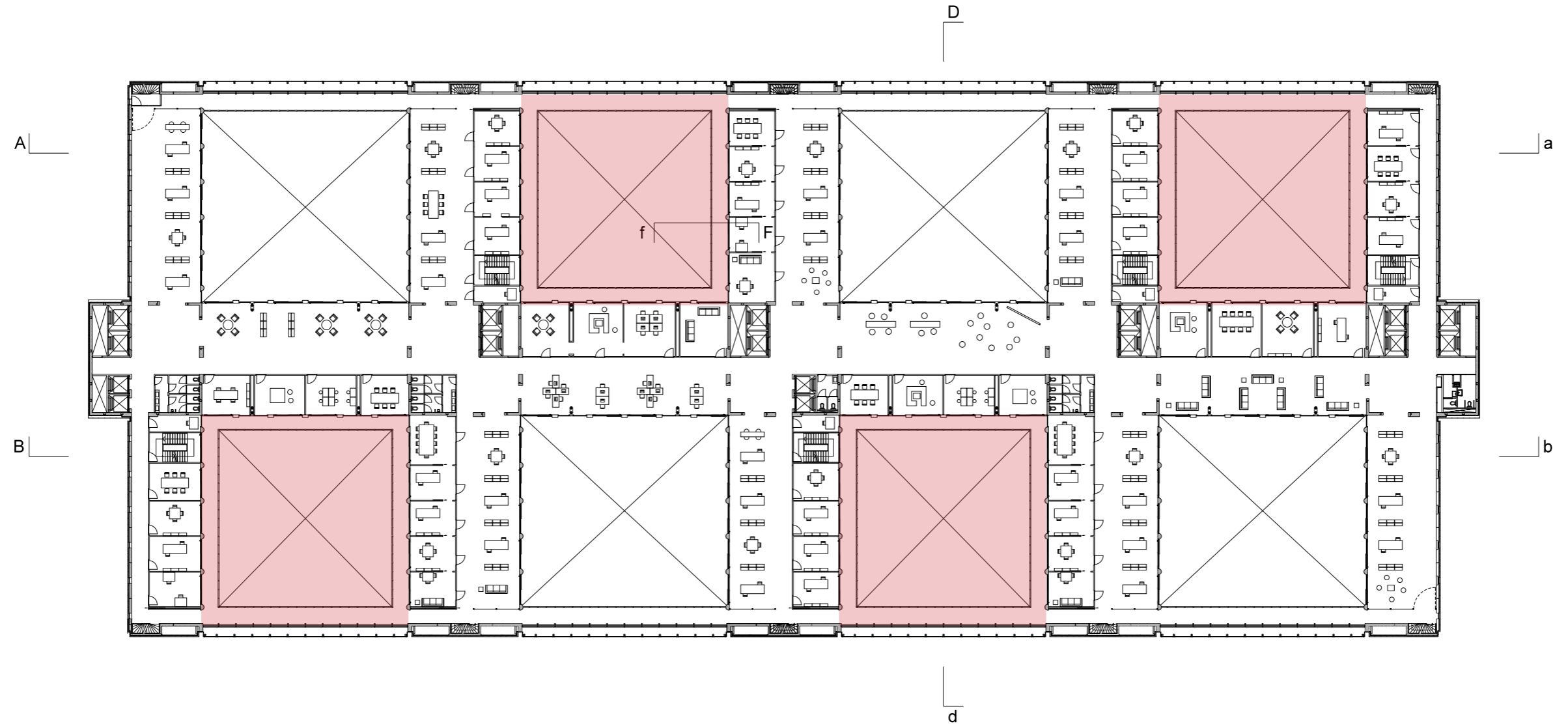

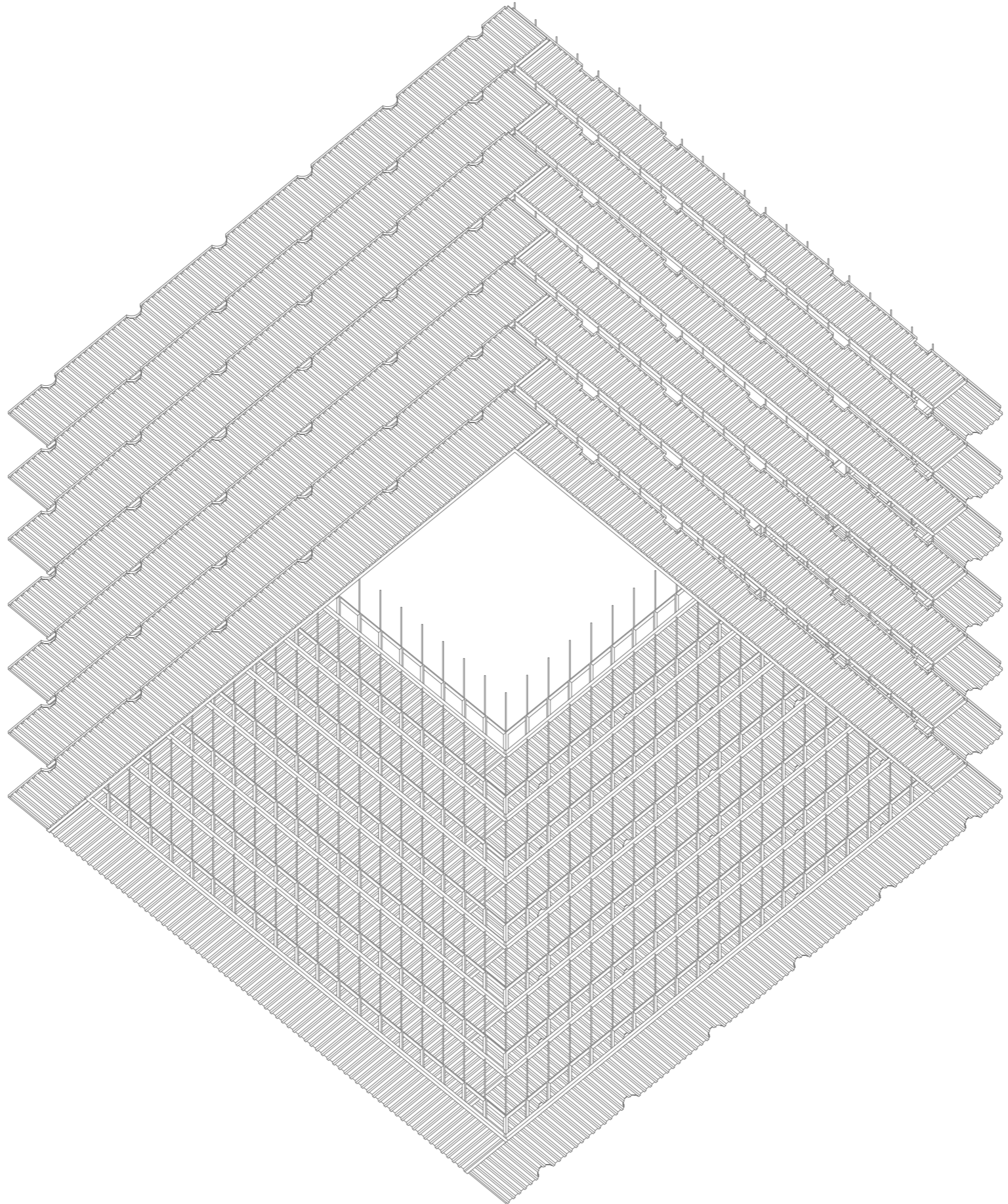

Detailed section balconies

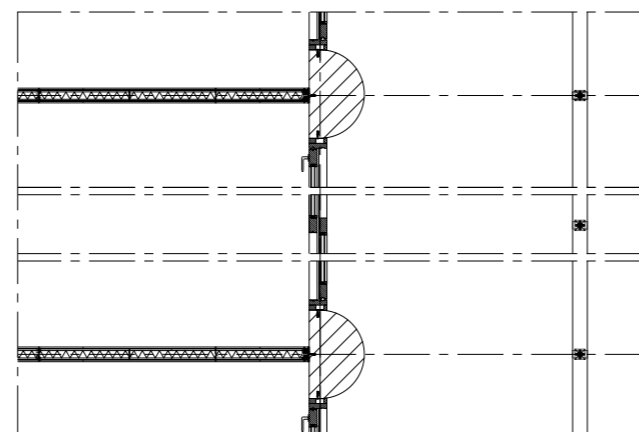
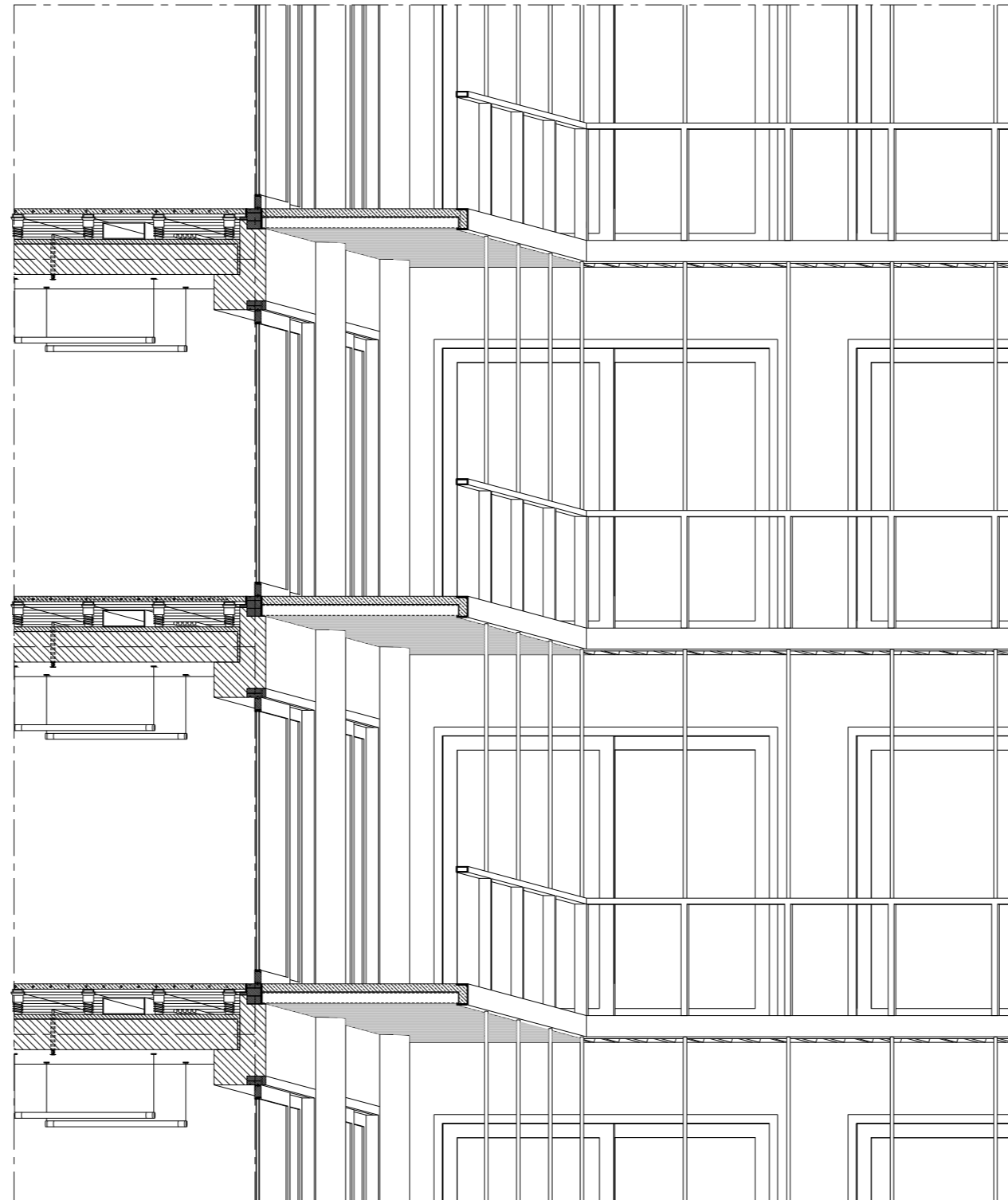

Details

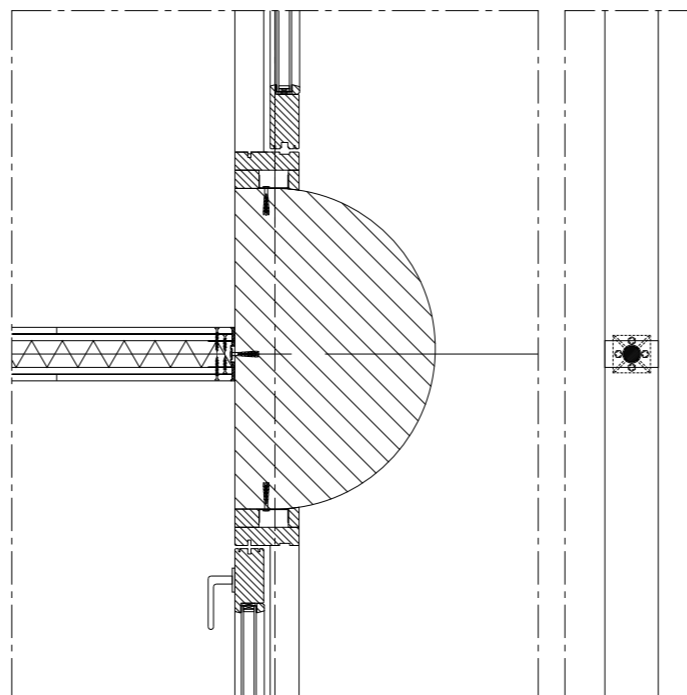
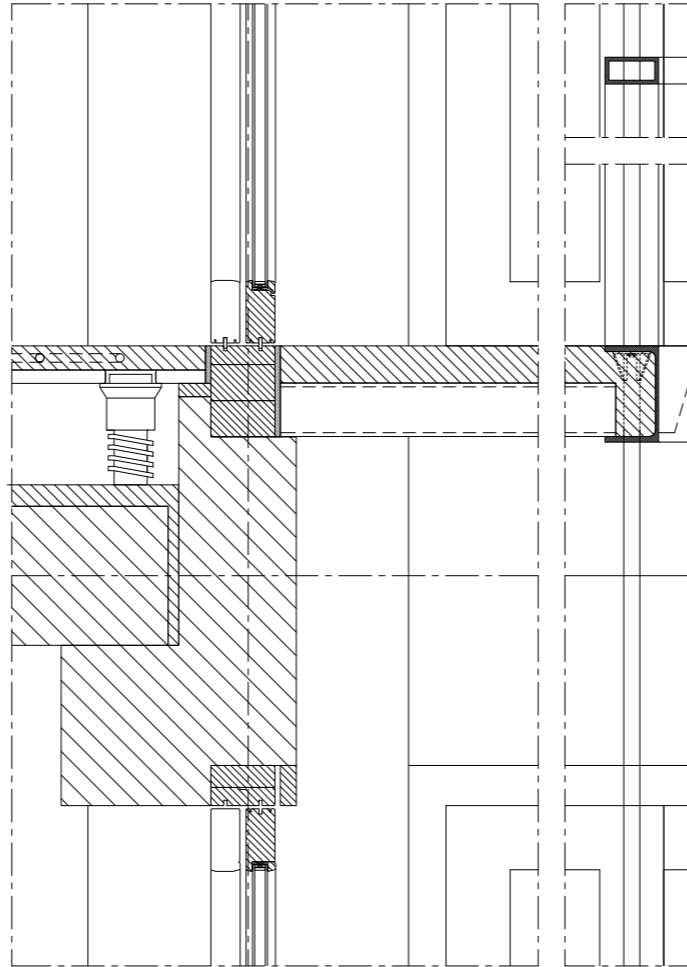



Thank you

P4 Presentation "The Place of Work"

Daan Vulkers

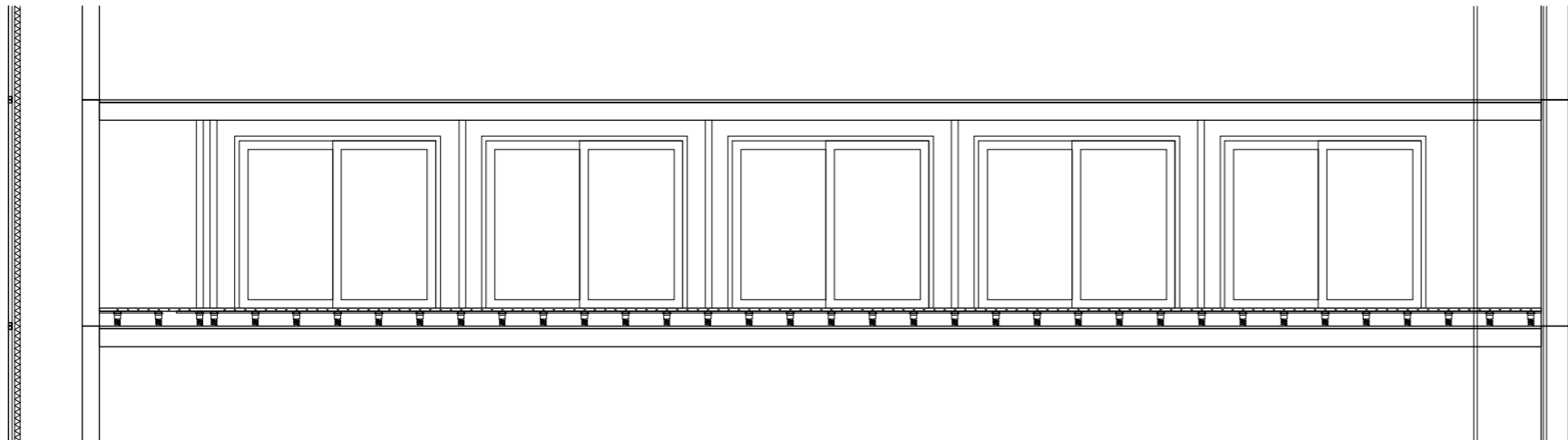

Office

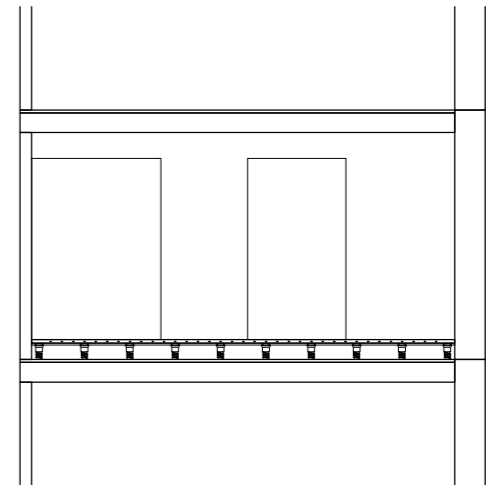

Core

