

 == \$0



# A VIRTUAL FUTURE FOR LONDON

TU DELFT FACULTY OF ARCHITECTURE  
DESIGN OF THE URBAN FABRIC

Annelies Broeders AUTHOR

Dr. ir. Stefan van der Spek MENTOR  
Dr. Stephen Read

10 July 2017 DATE

MASTER GRADUATION PROJECT

# PROBLEM

PRIVACY

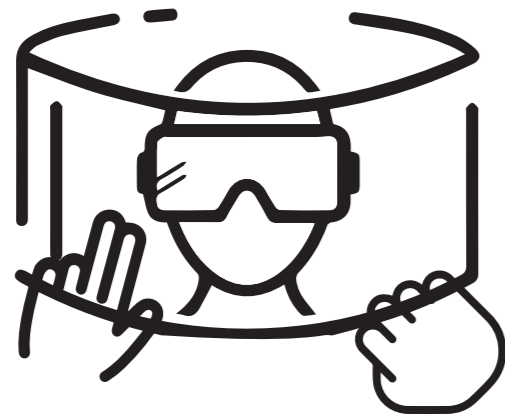

ANONYMITY

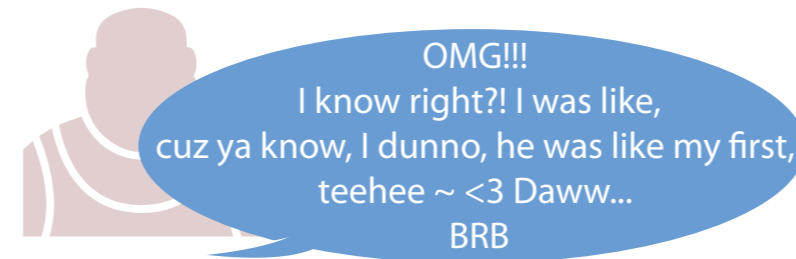

REMOVED SECURITY

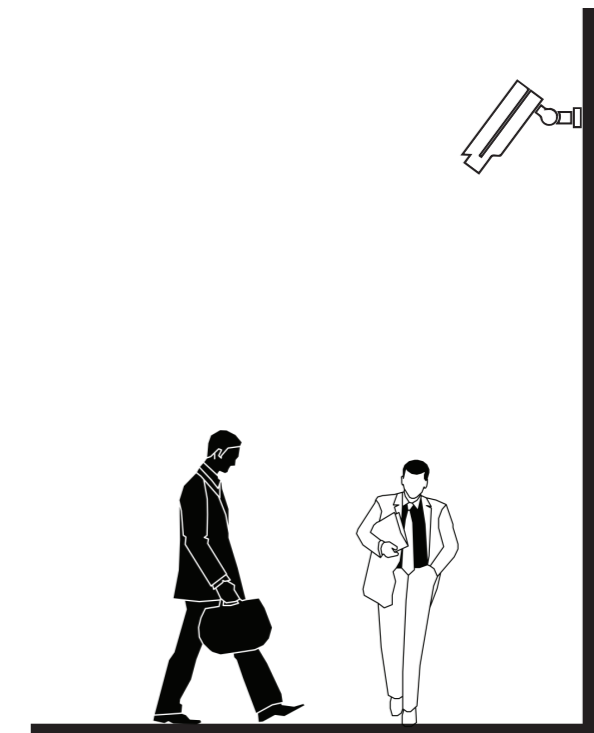

Abstraction(transactions)



Concrete form (objects)



## Experience of privacy

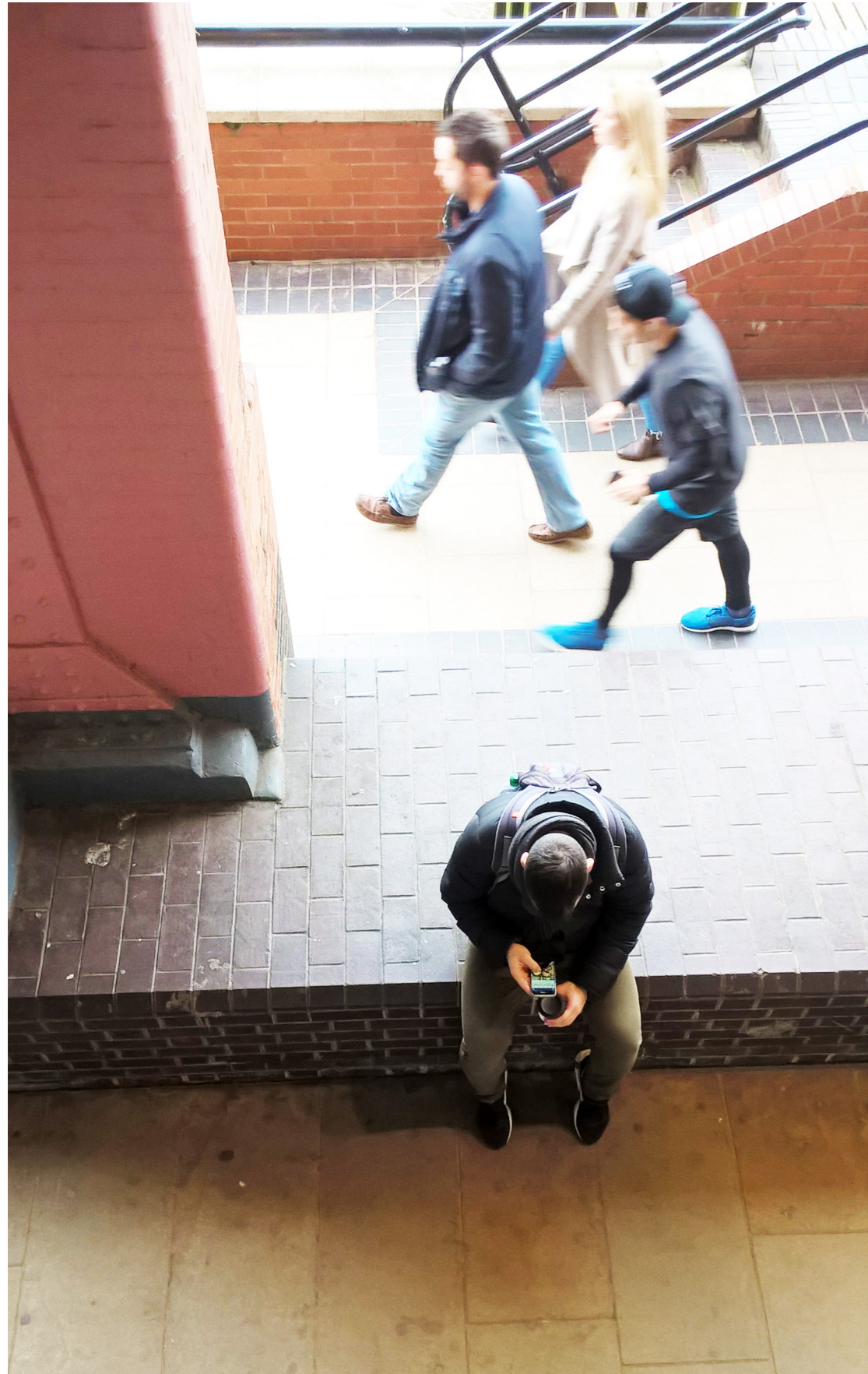

## Walls and fences

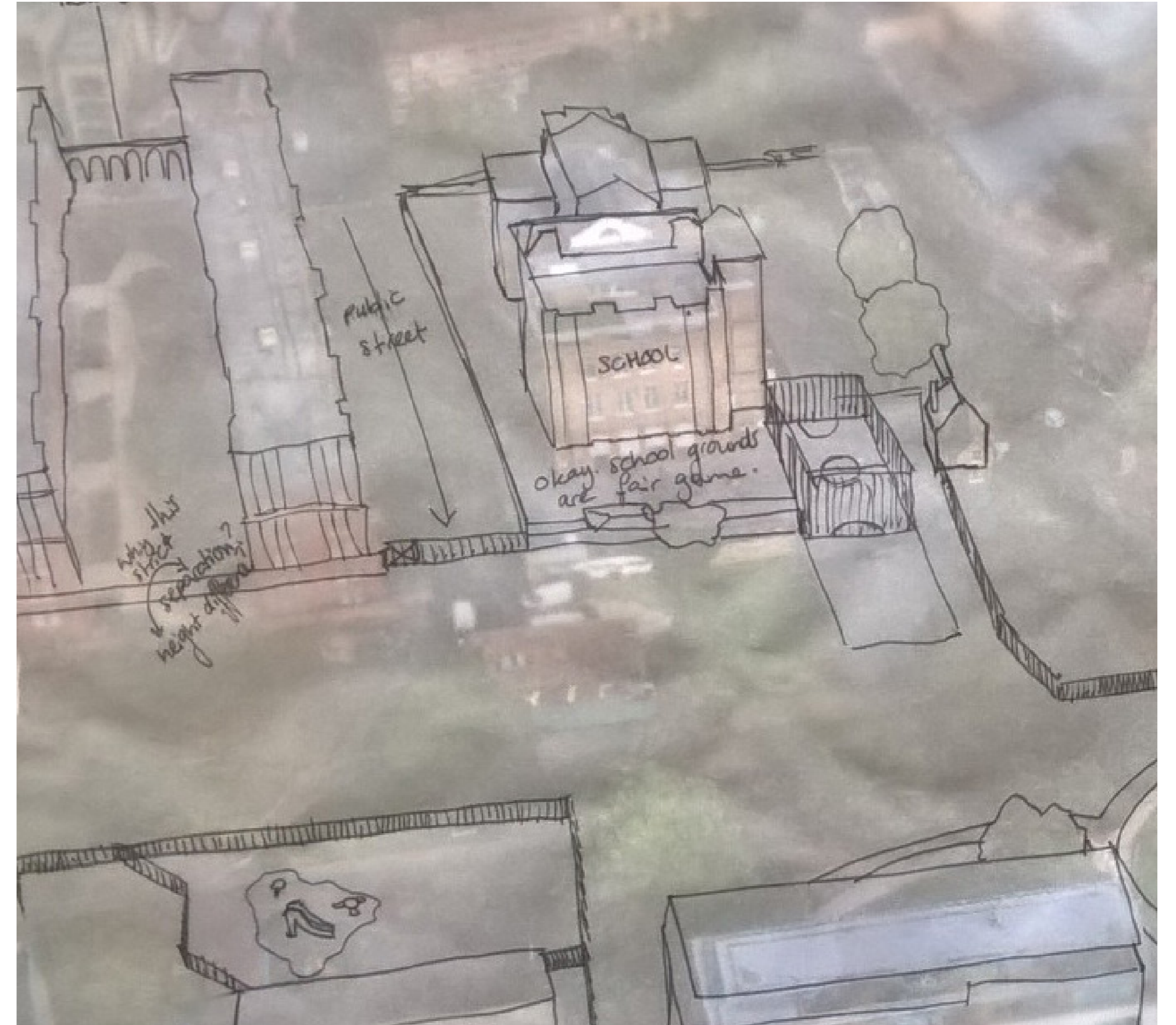

# Removed responsibility

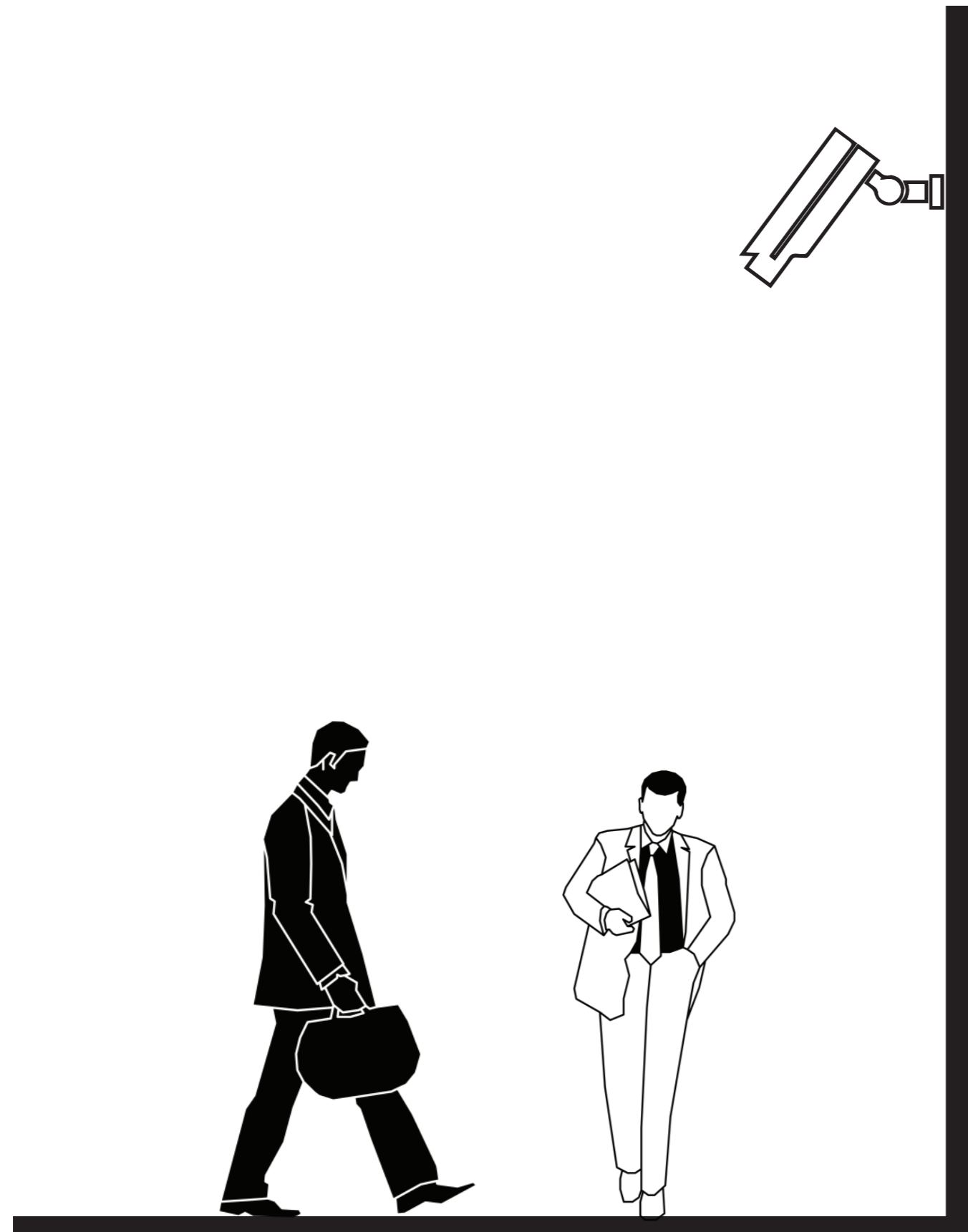

# person-objectrelationships

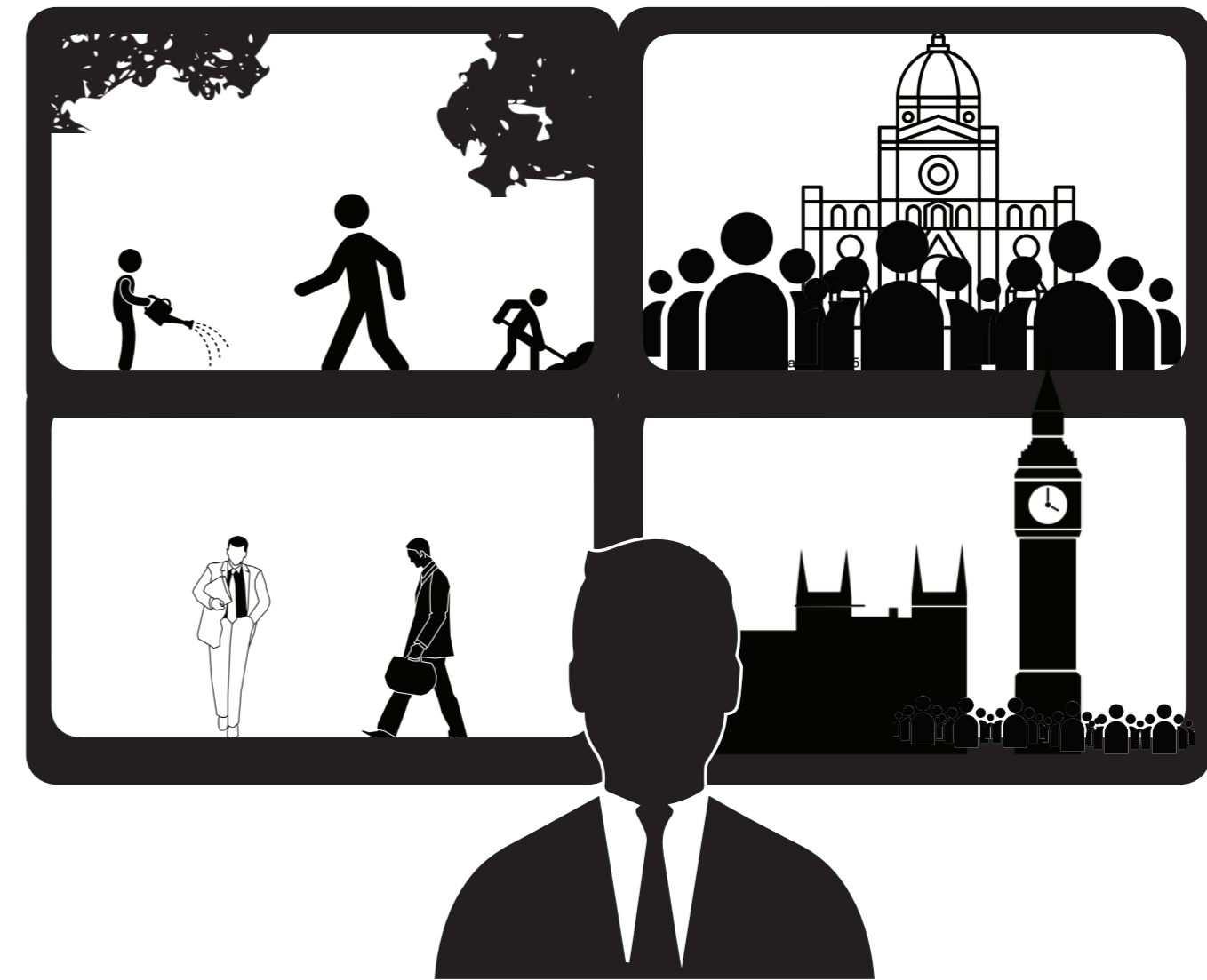

Where's Waldo childrens game. Using the anonymity of the crowd as puzzle.  
Via <http://www.culledculture.com/the-existentialism-of-wheres-waldo/>



C-SECTION COMICS

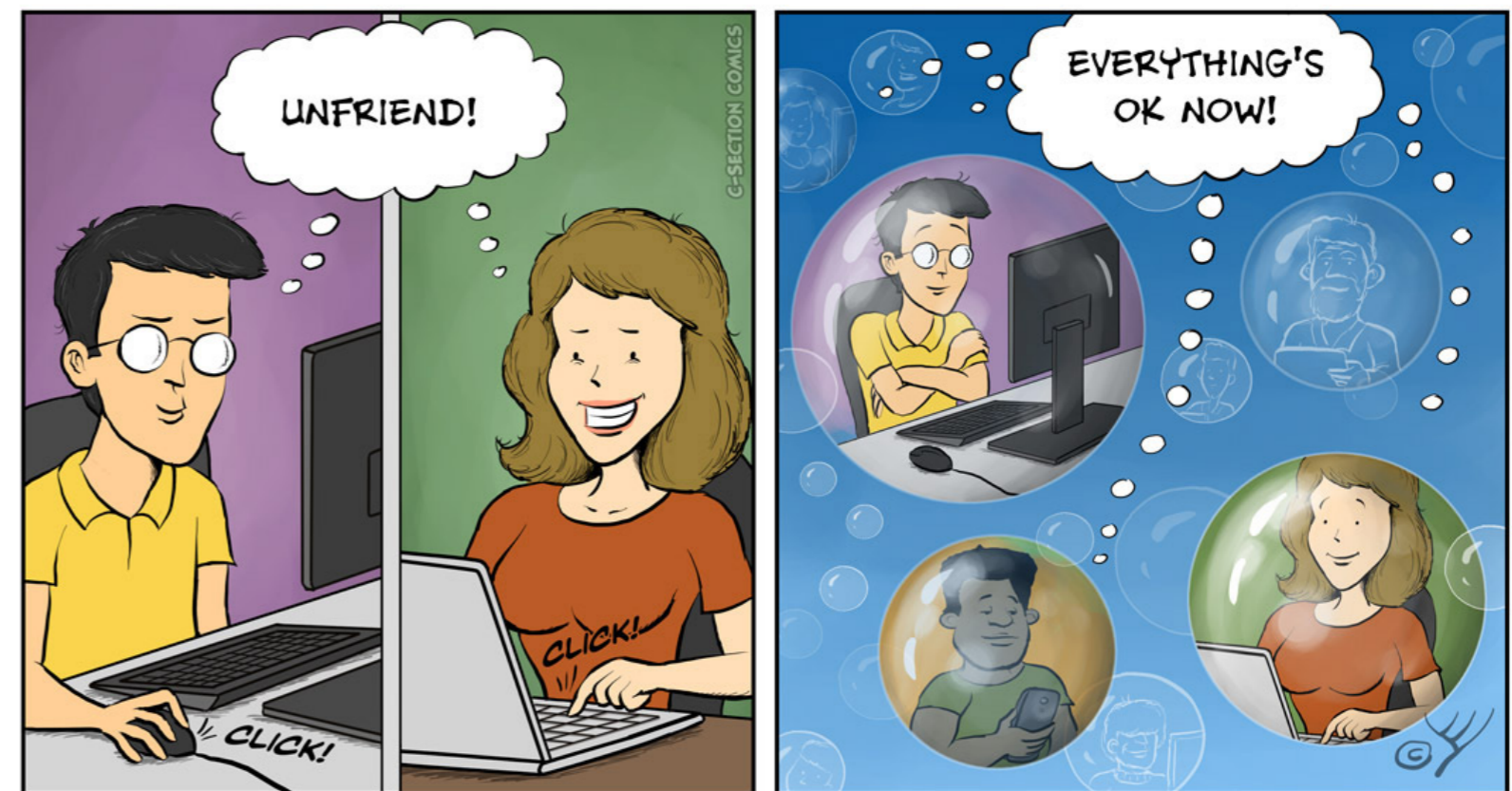
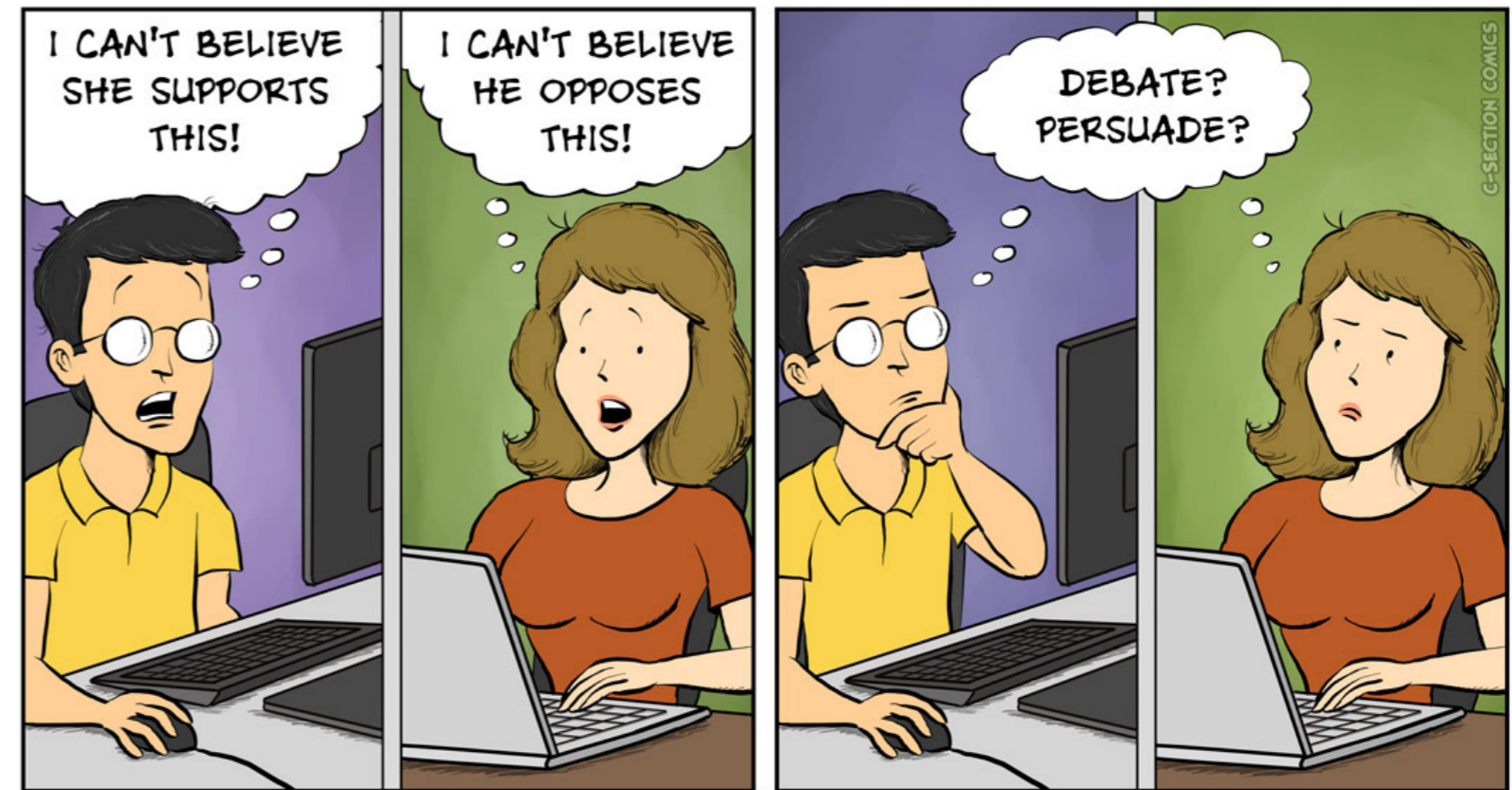

C-SECTION COMICS

ALL RIGHTS RESERVED ©

CSECTIONCOMICS.COM



New york



London



Tokyo

## Anonymity of remote ownership

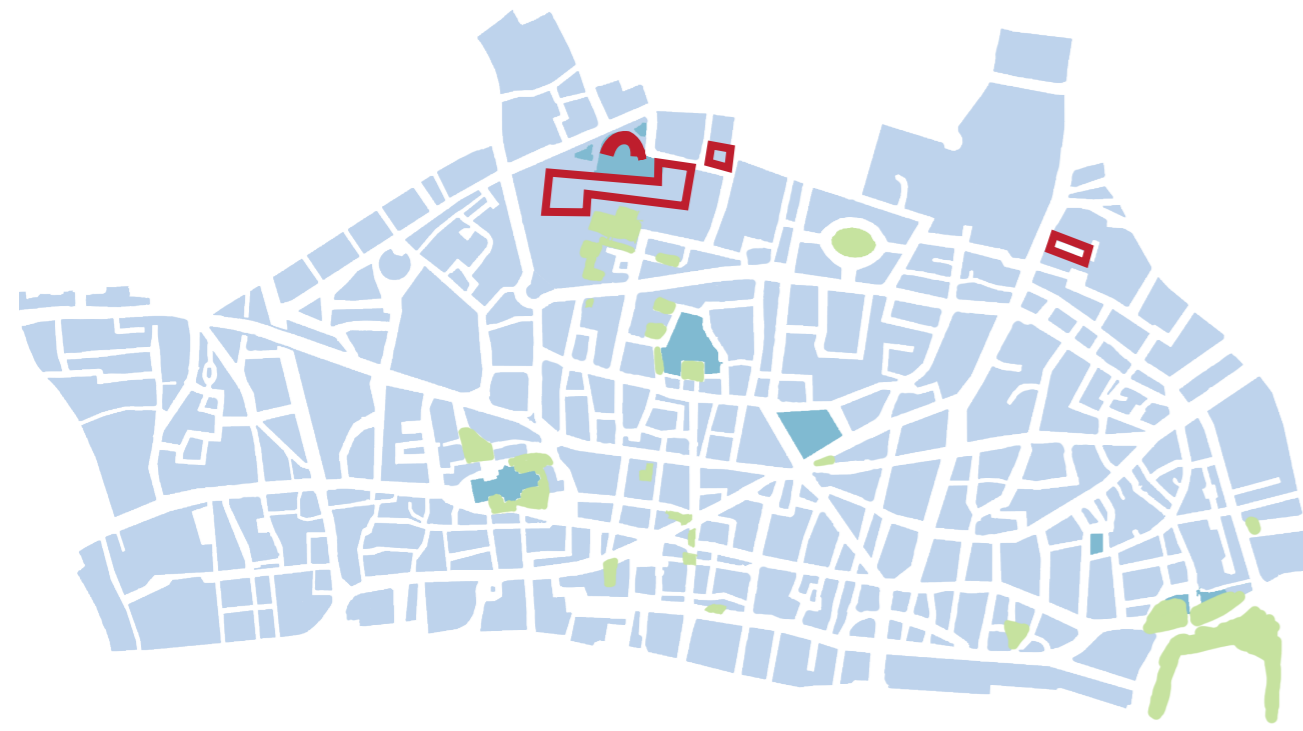

4500 homes in the Square mile in small enclaves

## Anonymity of the crowd



roughly 441.000 people travel to work every day

## Anonymity of remote security

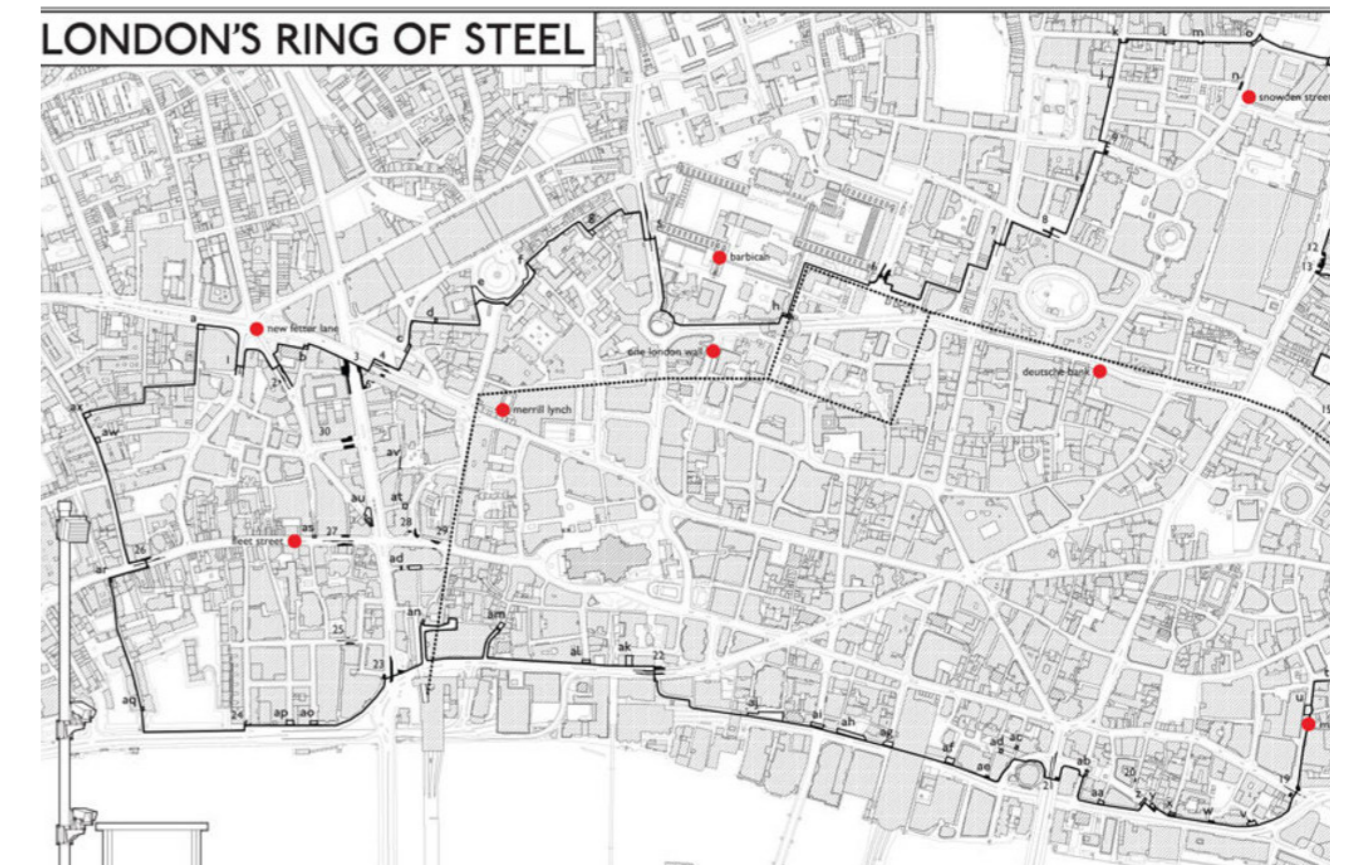

London Ring of Steel new fully automated city wall

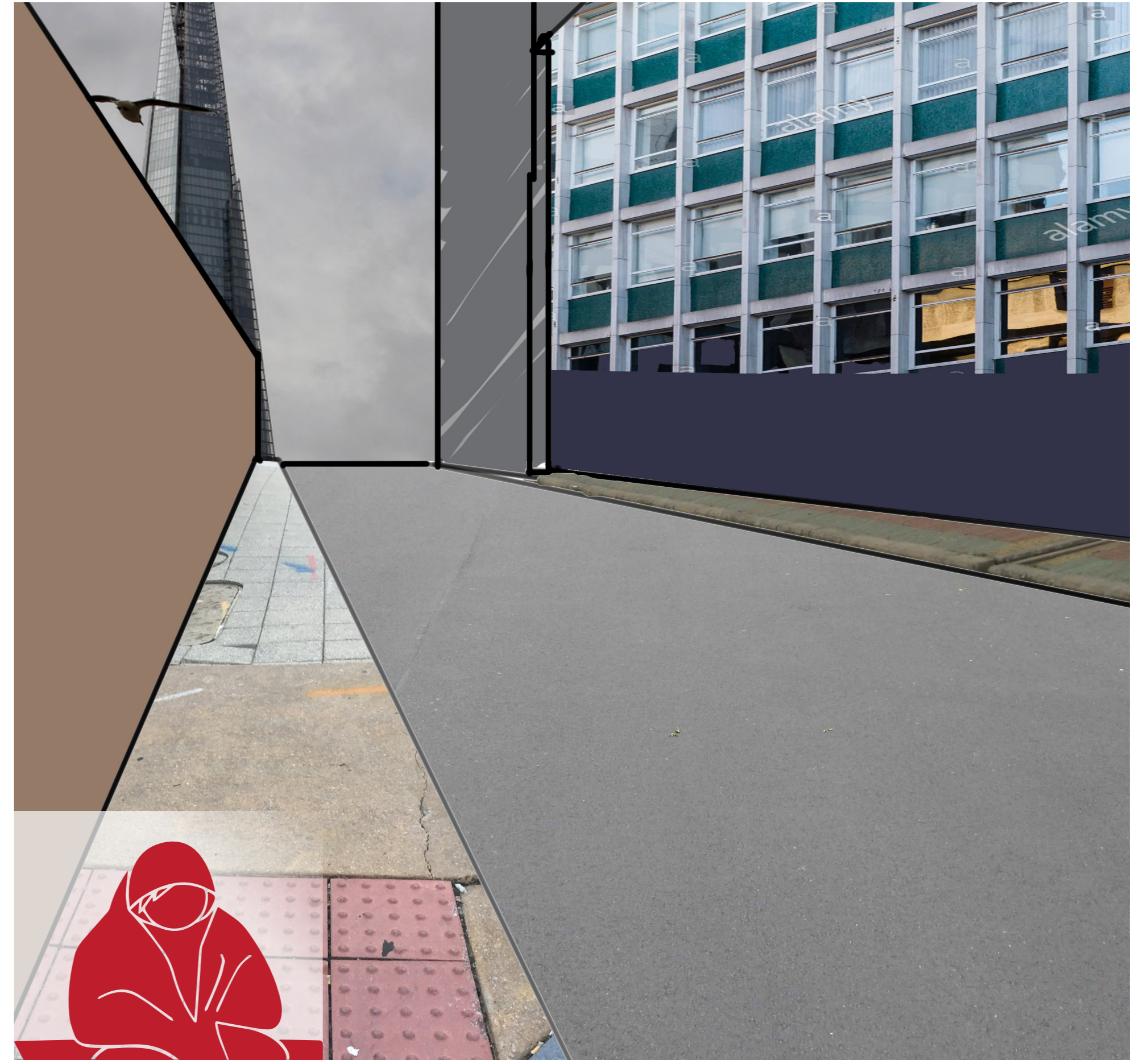

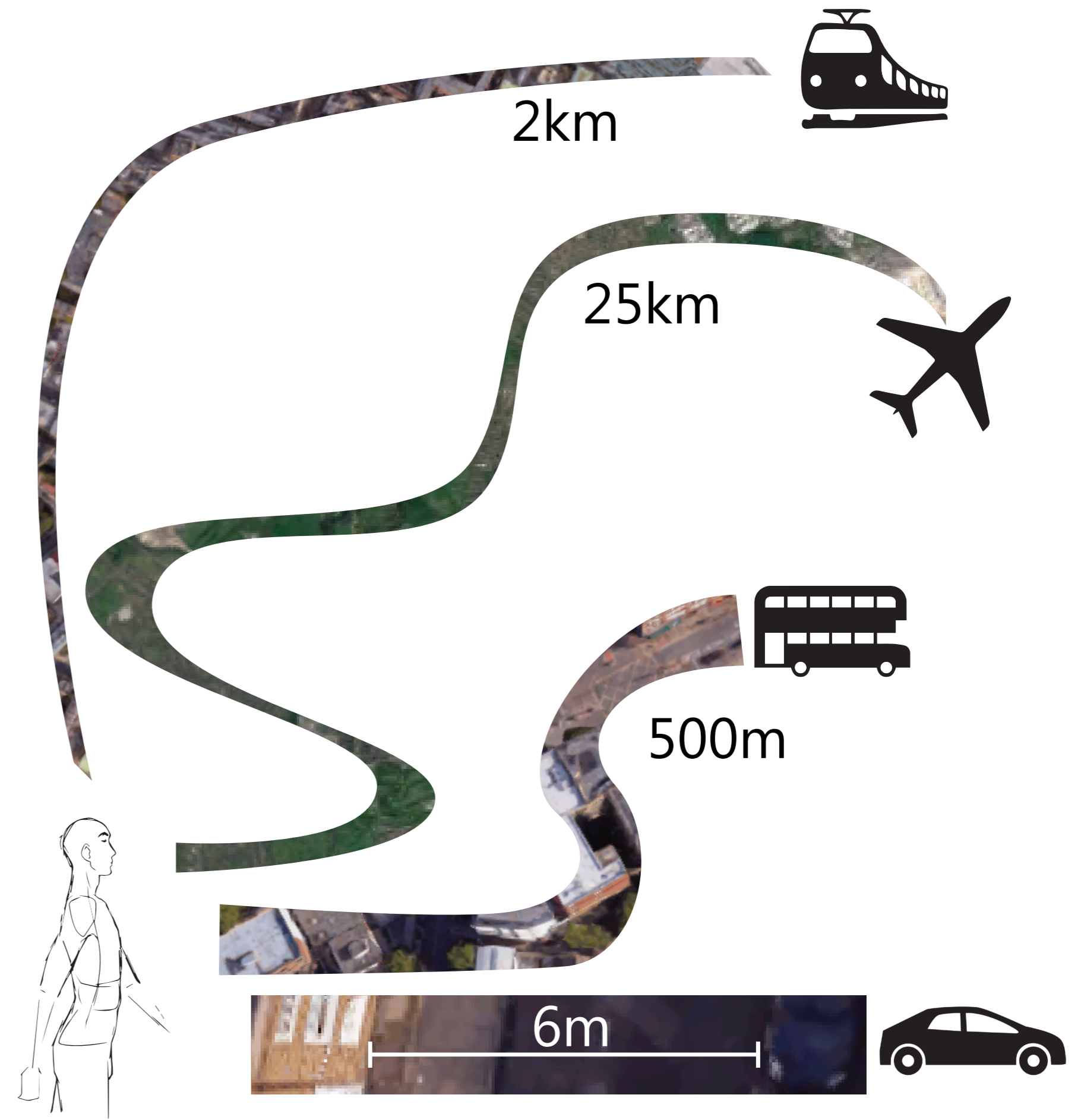
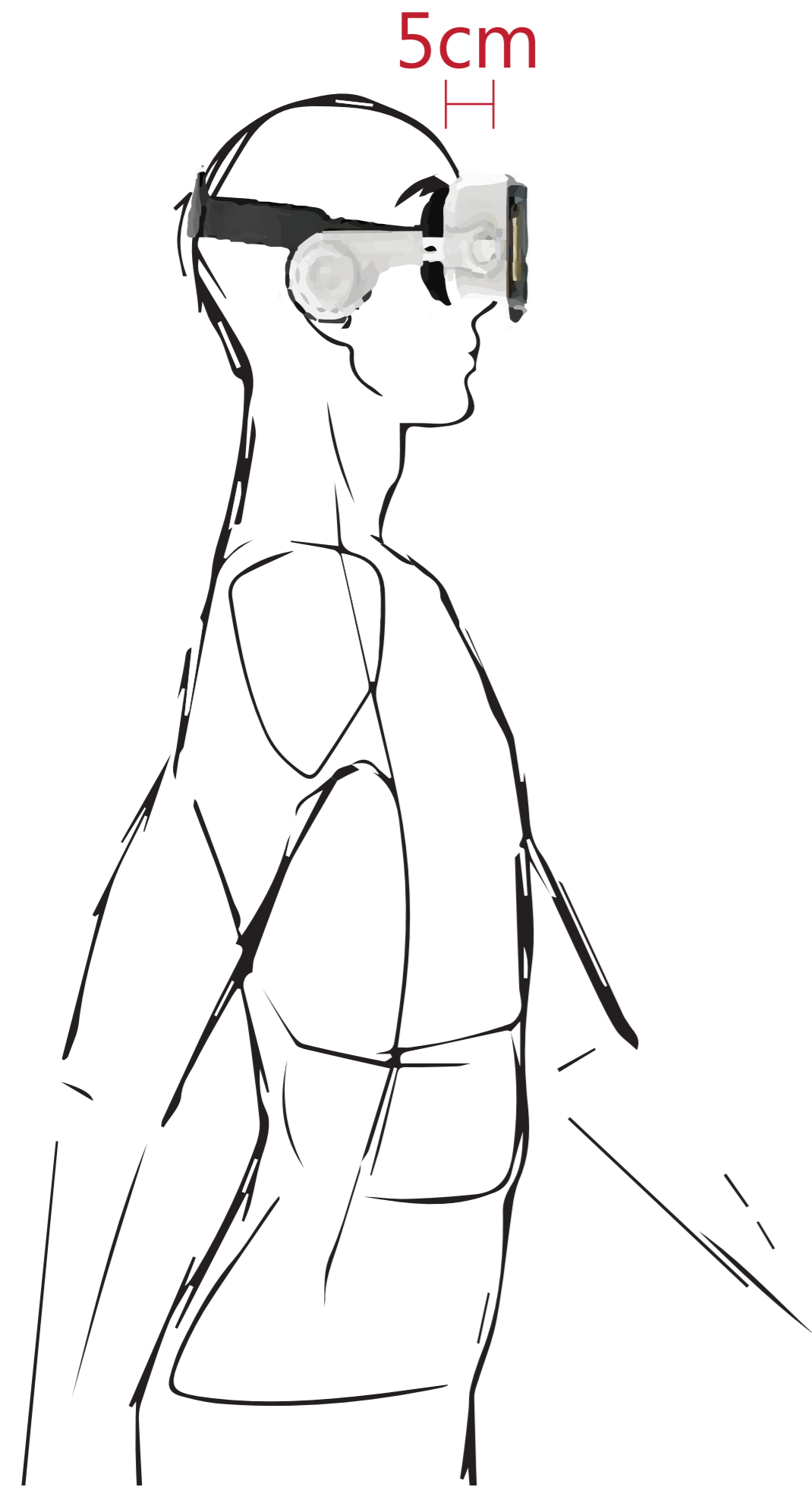

***The (urban) public space is the only place where we can encounter a cross-section of humanity***

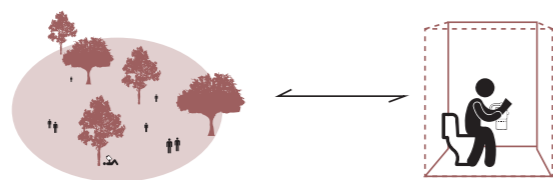
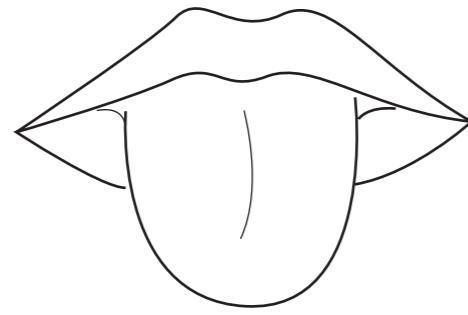



# DESIGN



# GOALS

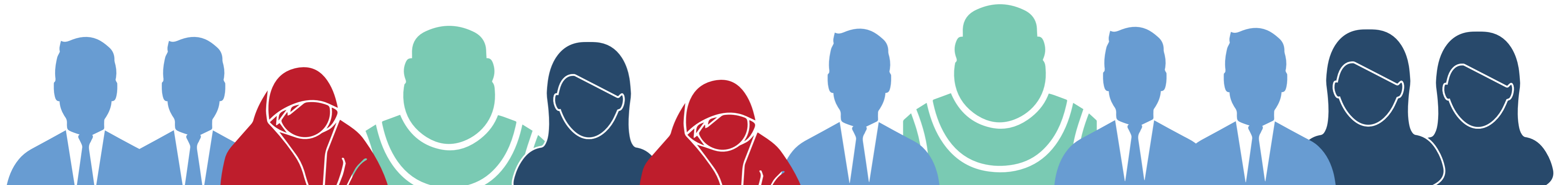
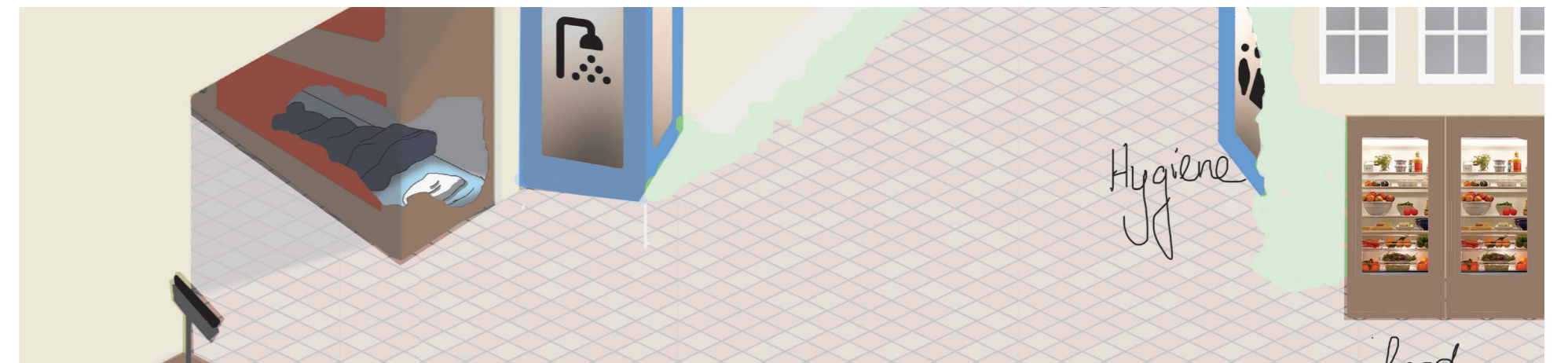
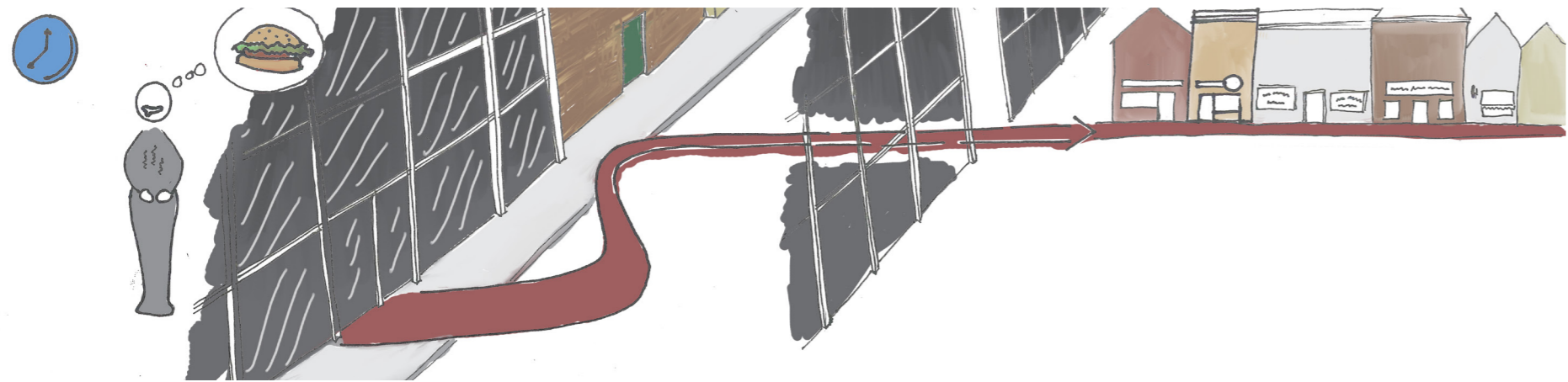

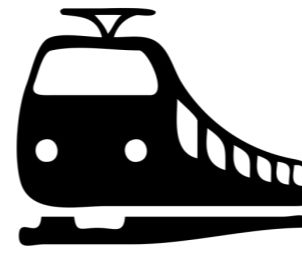

Created by misirlou from the Noun Project



Created by Anshul Ahuja from the Noun Project

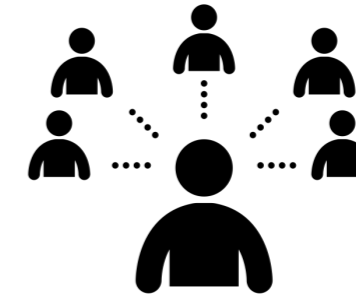

Created by Matt Hawdon from Noun Project

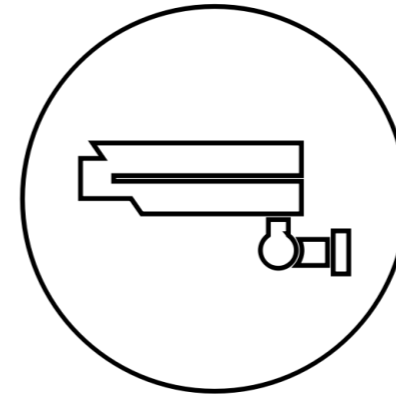
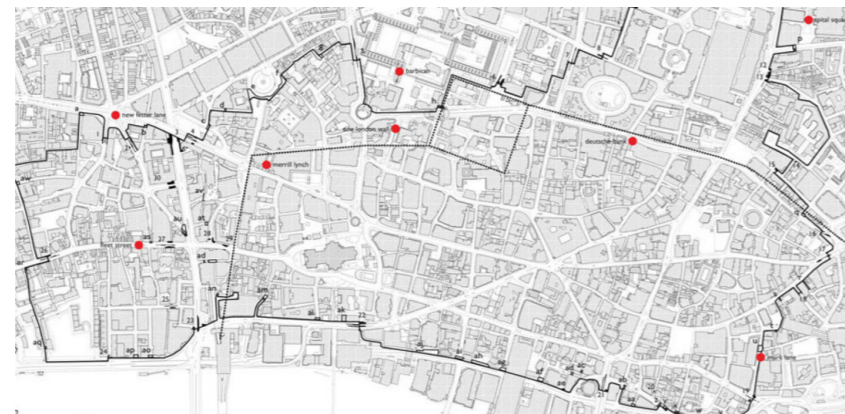

Created by James Fenton from Noun Project



Created by Erin Standley from Noun Project

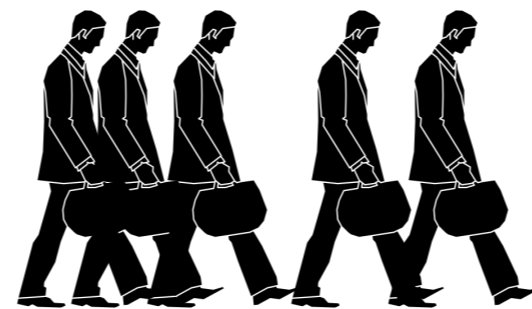
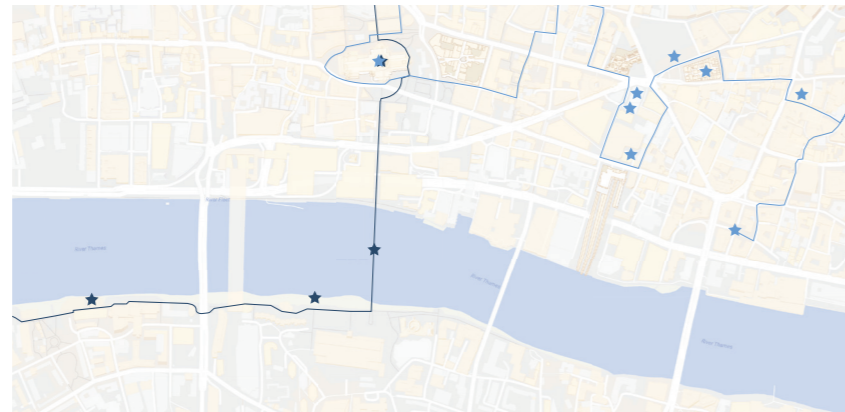

Created by Luis Iborra from the Noun Project



Created by Pedro Santos from Noun Project



Created by 1516 from Noun Project



Created by Erin Standley from Noun Project

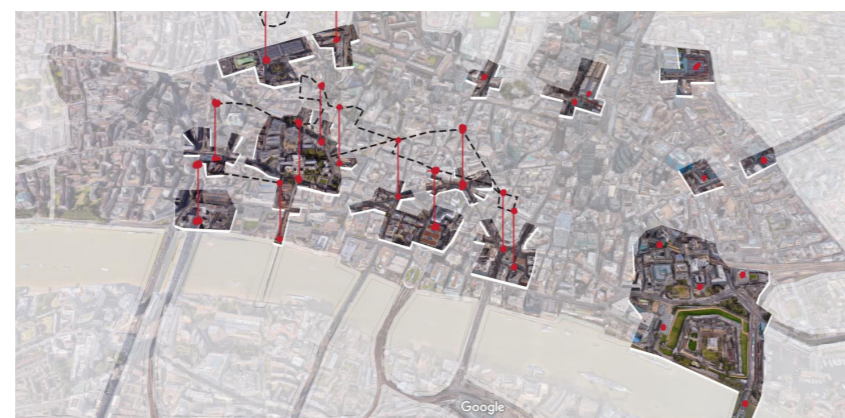

Created by Luis Iborra from the Noun Project

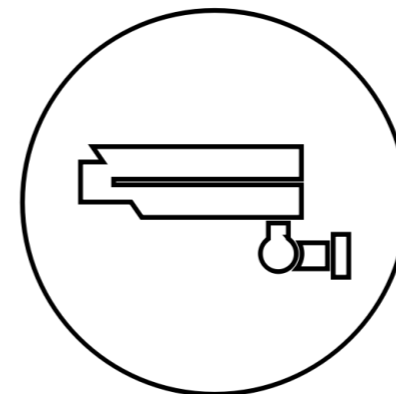

Created by Adrien Coquet from Noun Project

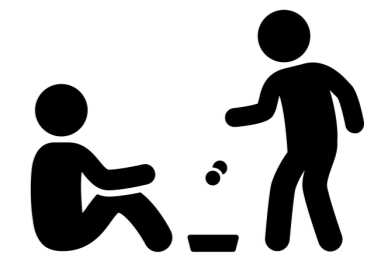

Created by Adrien Coquet from Noun Project

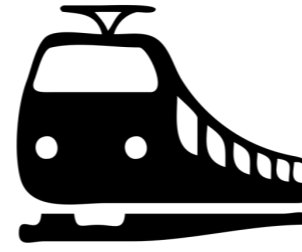

Created by misrlou from the Noun Project



Created by Anshul Ahuja from the Noun Project

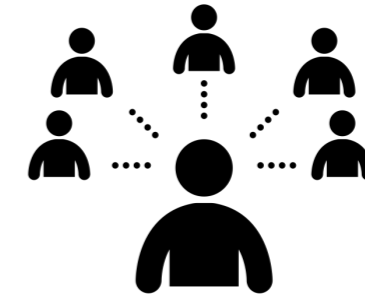

Created by Matt Hawdon from Noun Project



Created by James Fenton from Noun Project



Created by Eric Stremme from Noun Project



Created by Luis Iborra from the Noun Project



Created by Pedro Santos from Noun Project



Created by 1516 from Noun Project



Created by Eric Stremme from Noun Project



Created by Luis Iborra from the Noun Project

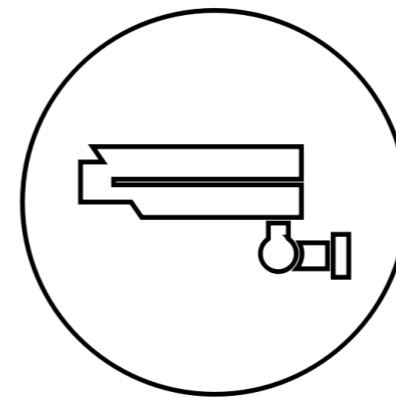

Created by Adrien Coquet from Noun Project

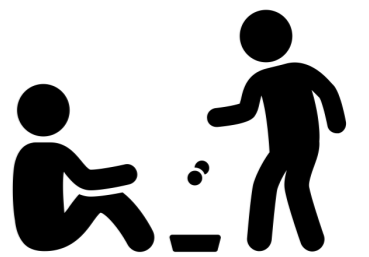

Created by Adrien Coquet from Noun Project

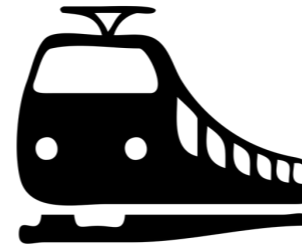

Created by misrlou  
from the Noun Project



Created by Anshul Ahuja  
from the Noun Project

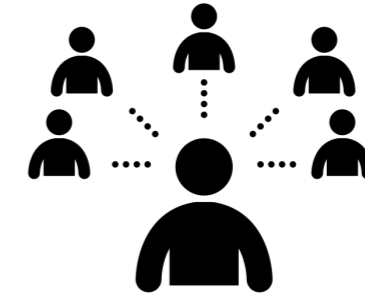

Created by Matt Hawdon  
from Noun Project

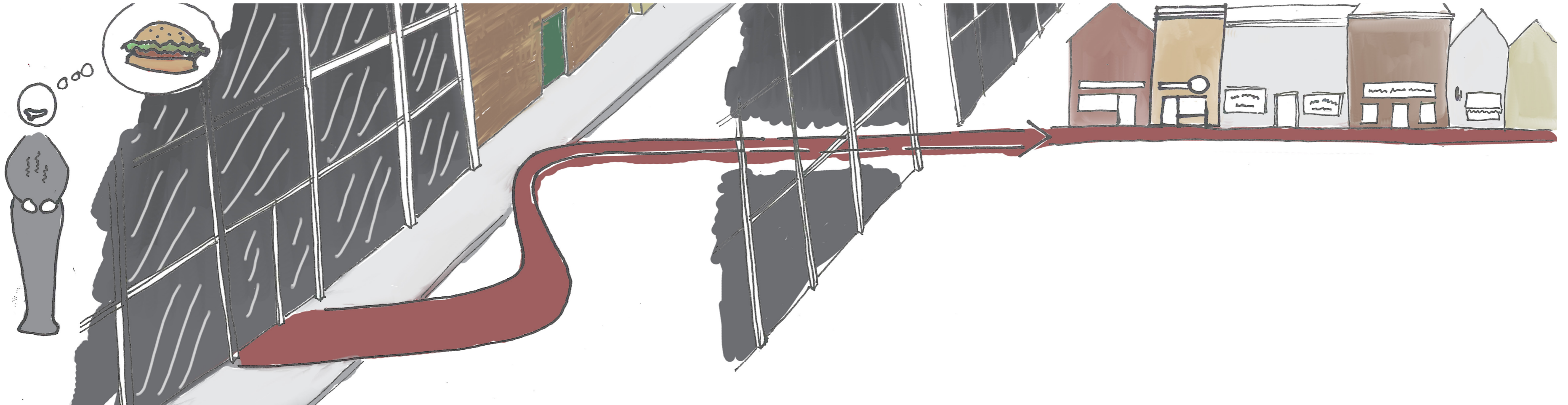



Created by mihiro from the Noun Project



Created by Anshul Ahuja from the Noun Project



Created by Matt Hawdon from Noun Project



*“The real world is the only place where you can get a decent meal” - ready player one*



## SELF-CONTAINED SPACES

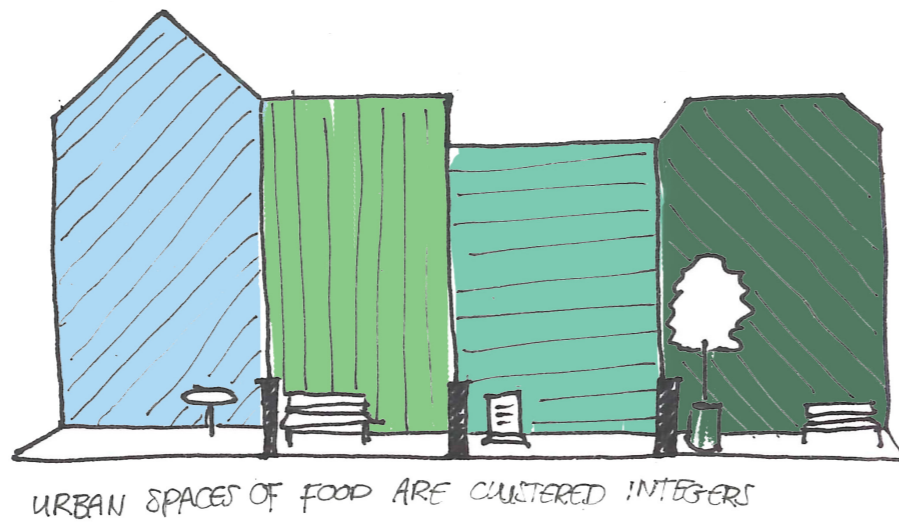

## SENSORY FOCUS

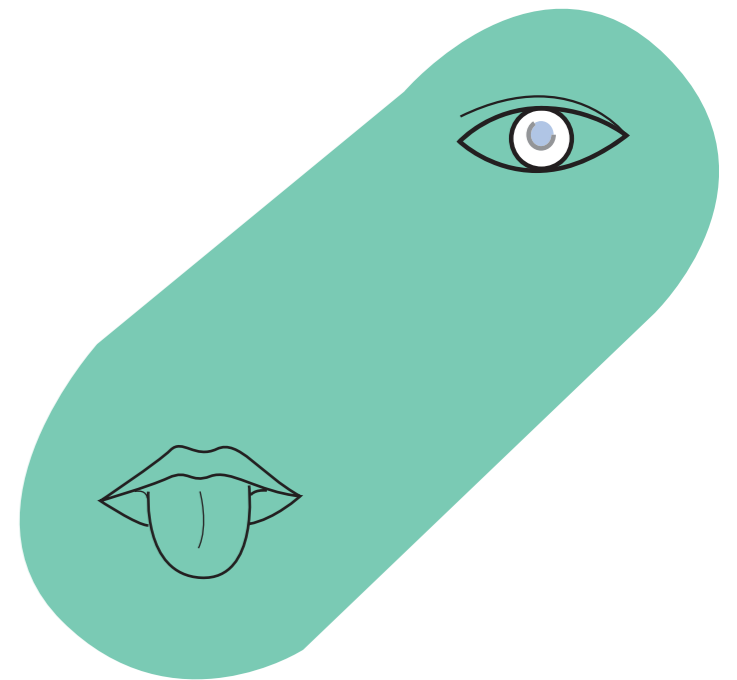
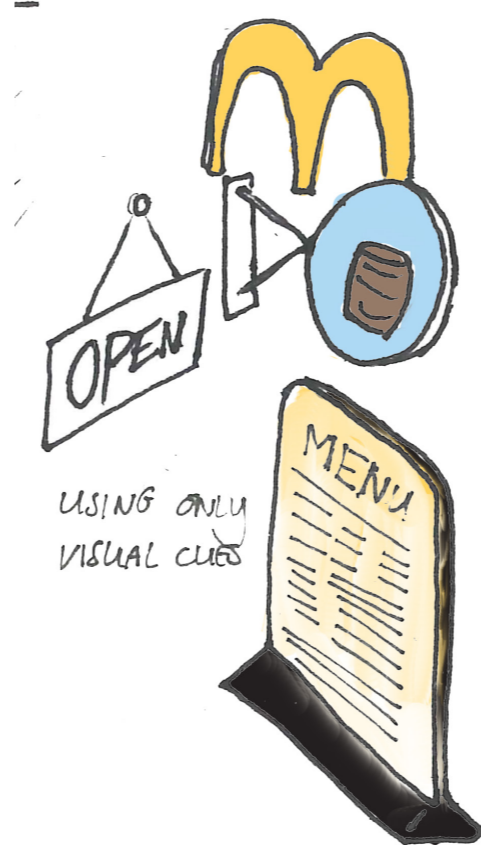

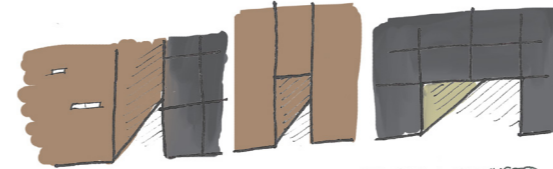

ALLEYS SEEM UNFRIENDLY, PRIVATE, DISCONNECTED

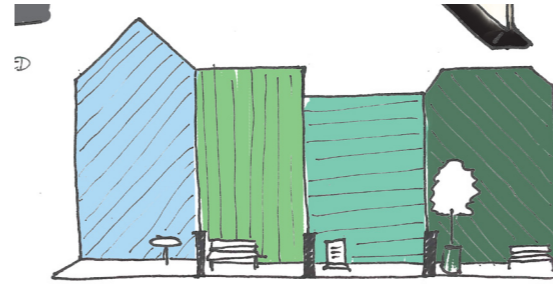

URBAN SPACES OF FOOD ARE CLUSTERED INTERIORS

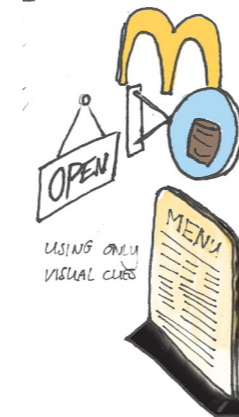

USING ONLY VISUAL CUES

PEDESTRIAN NETWORK

FOODCOURTS

VERTICAL HERB GARDENS

# PEDESTRIAN NETWORK

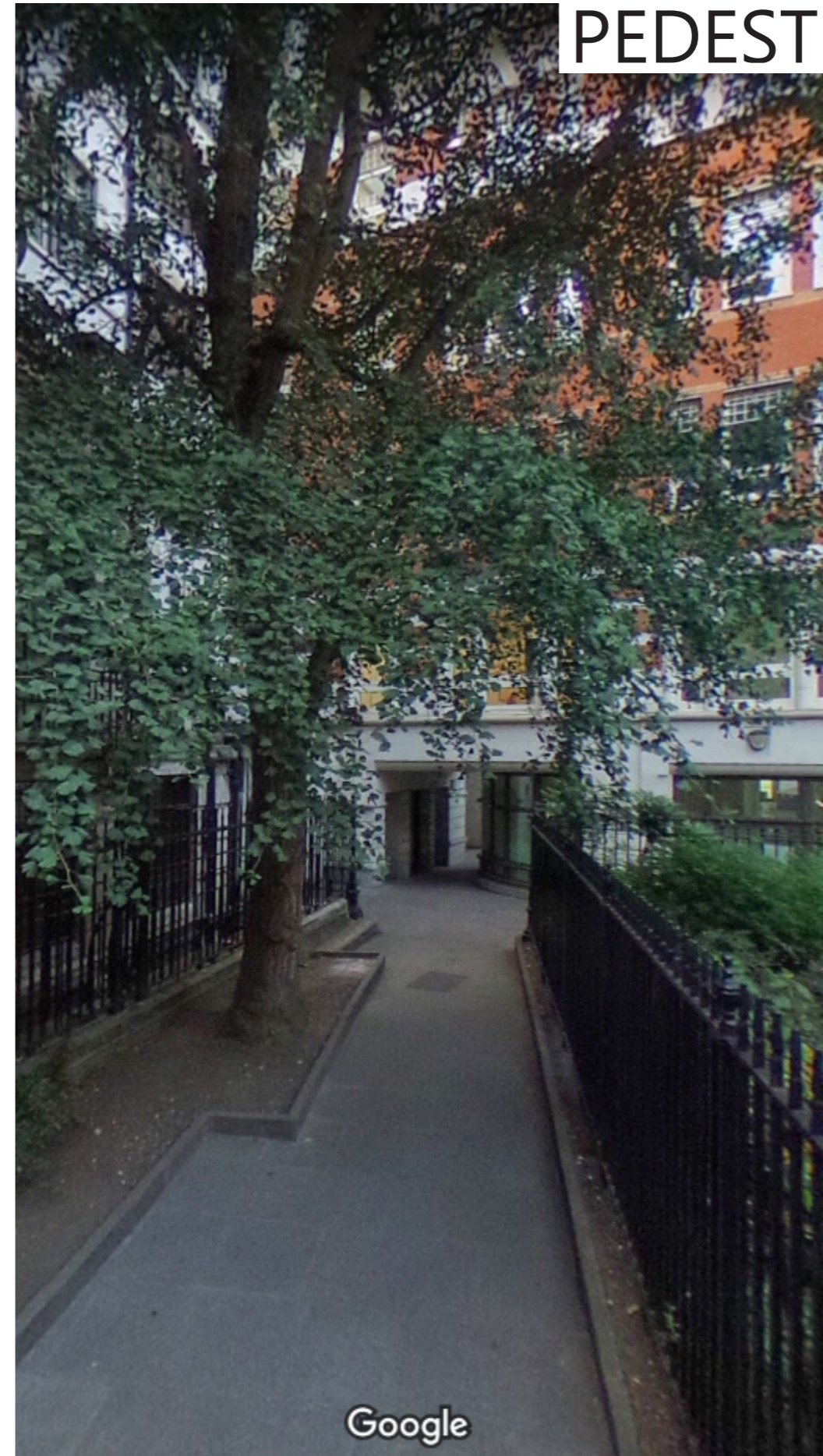

# PEDESTRIAN NETWORK

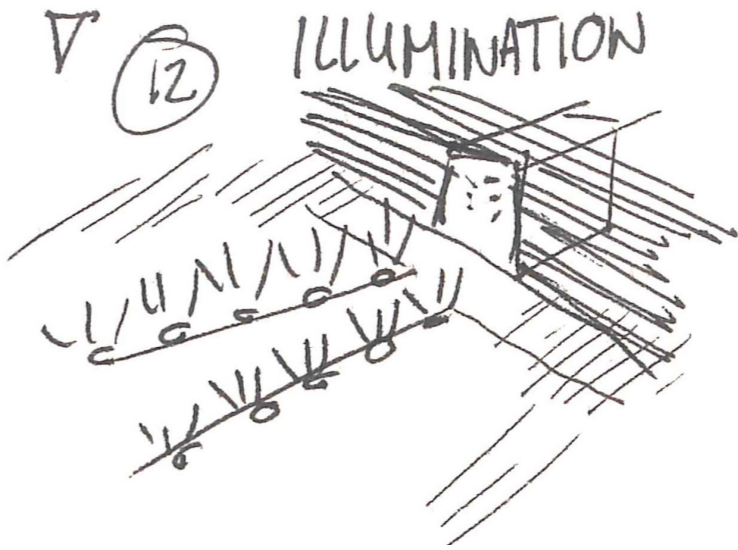
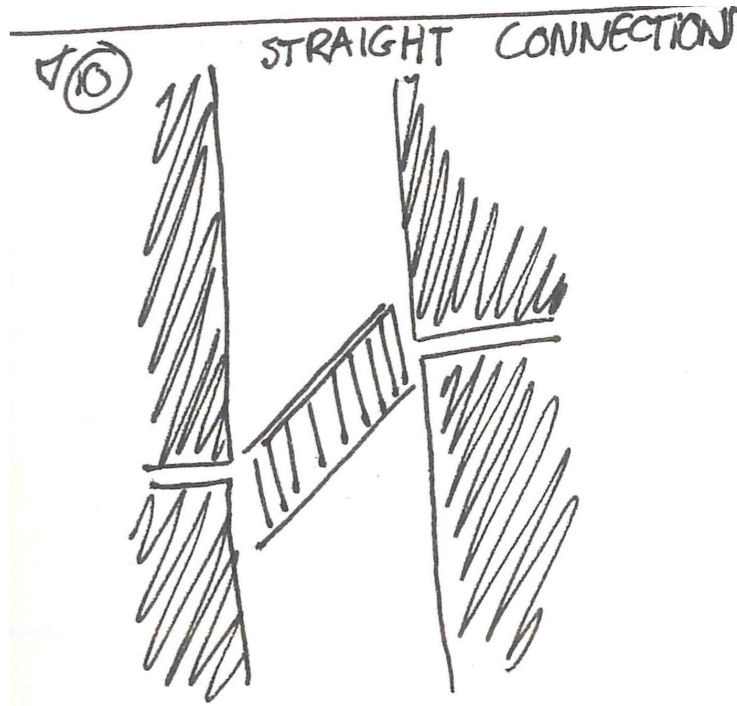
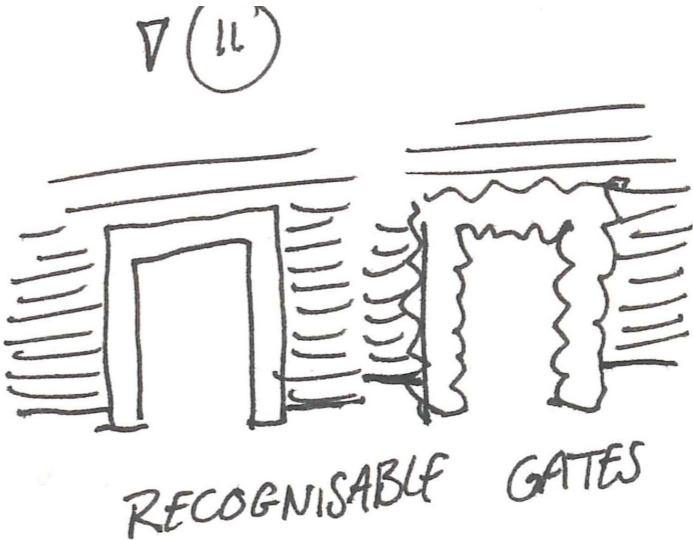



# VERTICAL HERB GARDENS

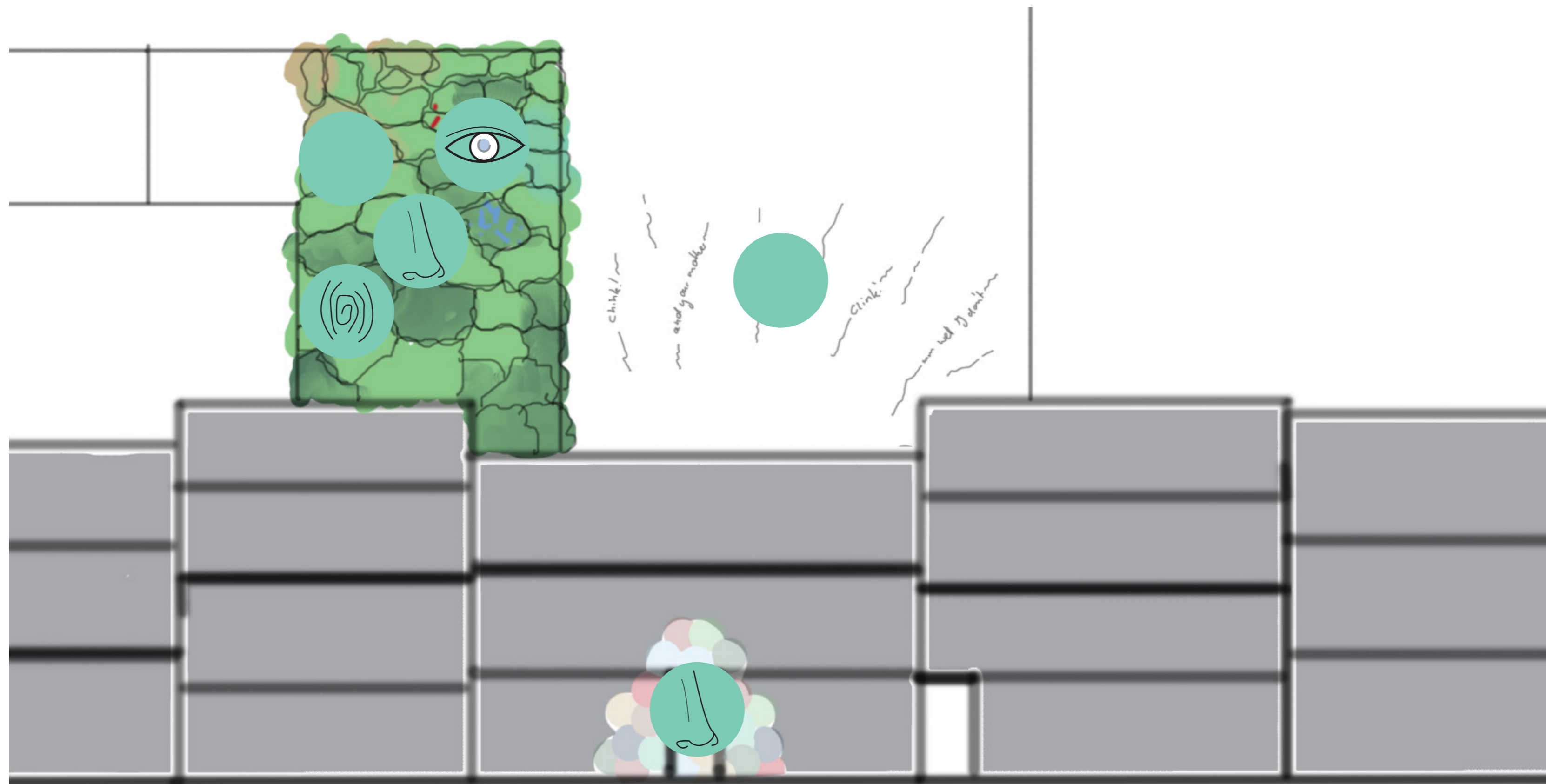
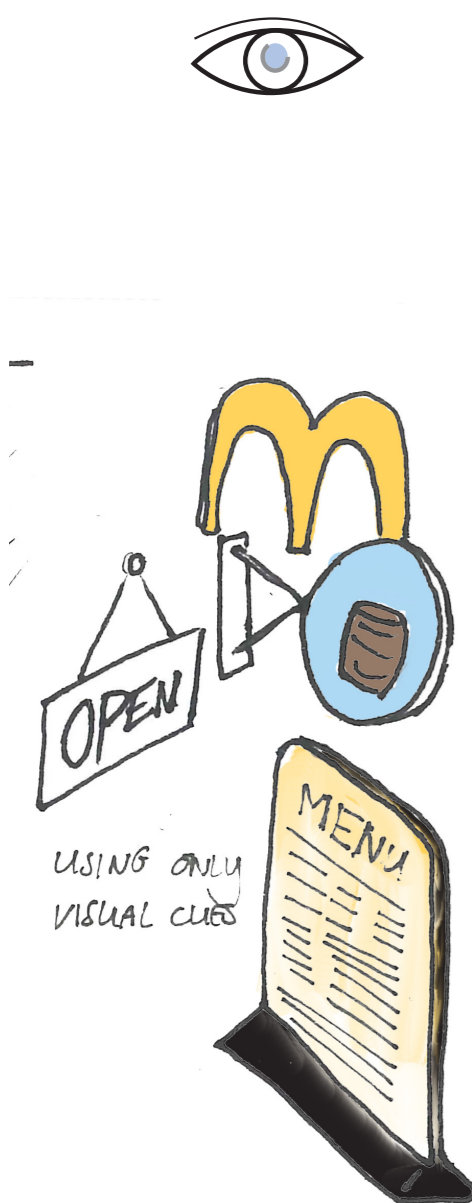
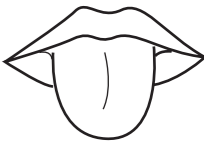

# VERTICAL HERB GARDENS

Argentinian

Gaicho



peppers; cumin; tomato; mint;

Asian/Filipino

MBER



turmeric; chilli; lemongrass; kaffir lime; mint; aubergine; peanut

British

The Temple Brewhouse

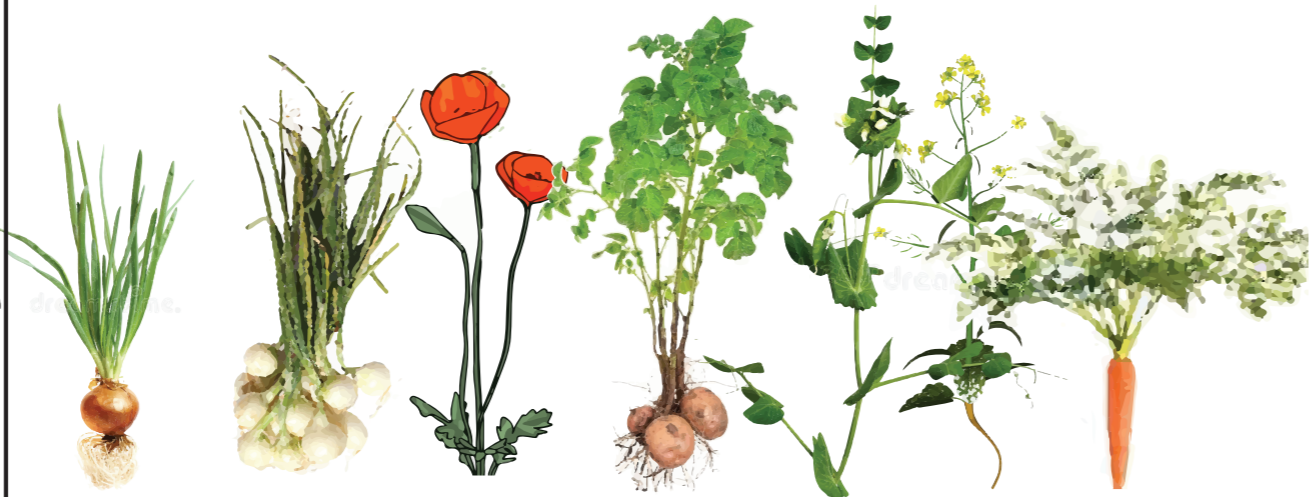

Onion; pearl onions; poppy; potato; peas; mustard; carrot









BOW LANE EC4

Pure

Share your daily meal



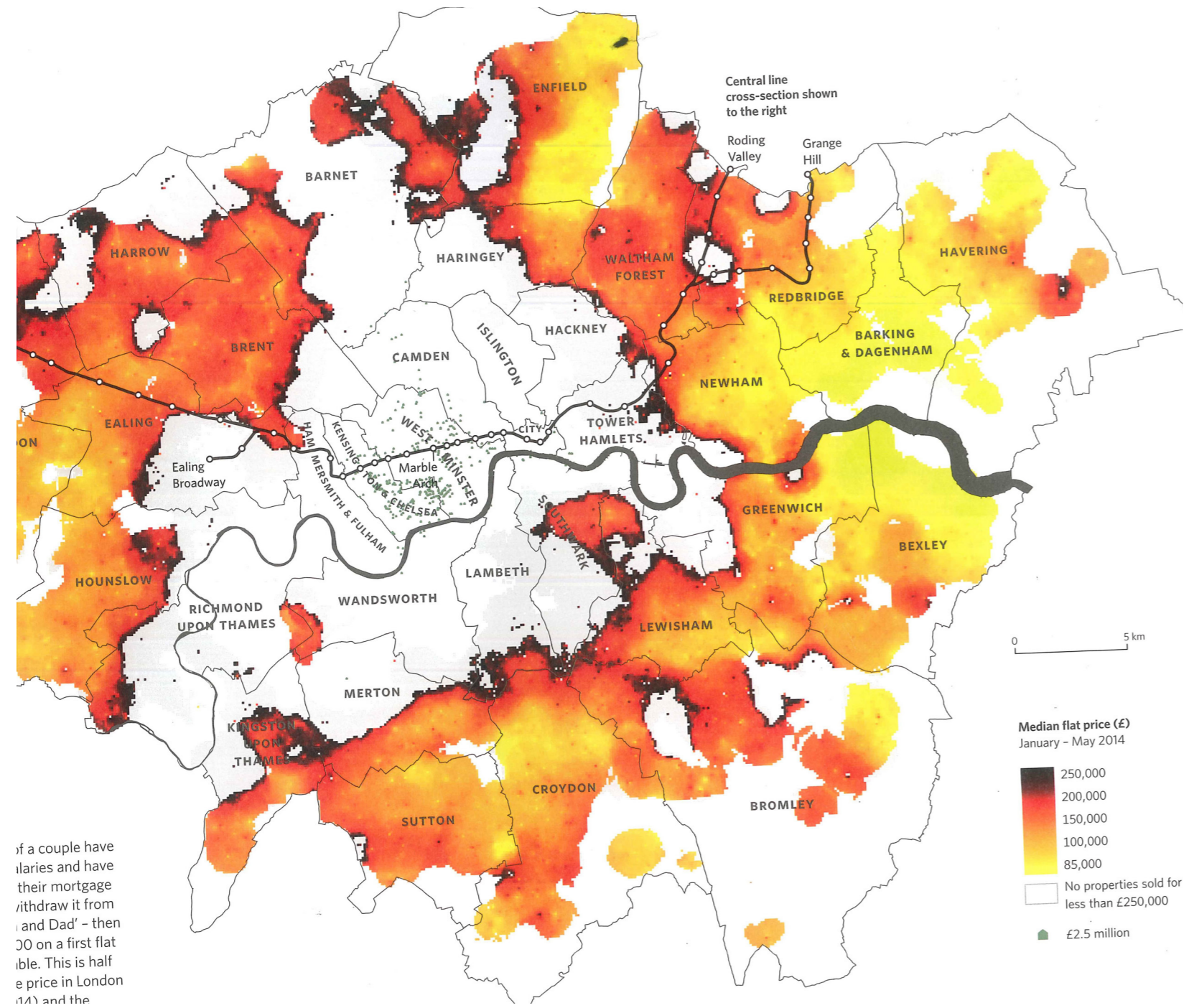

If a couple have salaries and have their mortgage withdrawn it from 'and Dad' - then 30 on a first flat sale. This is half the price in London (14) and the

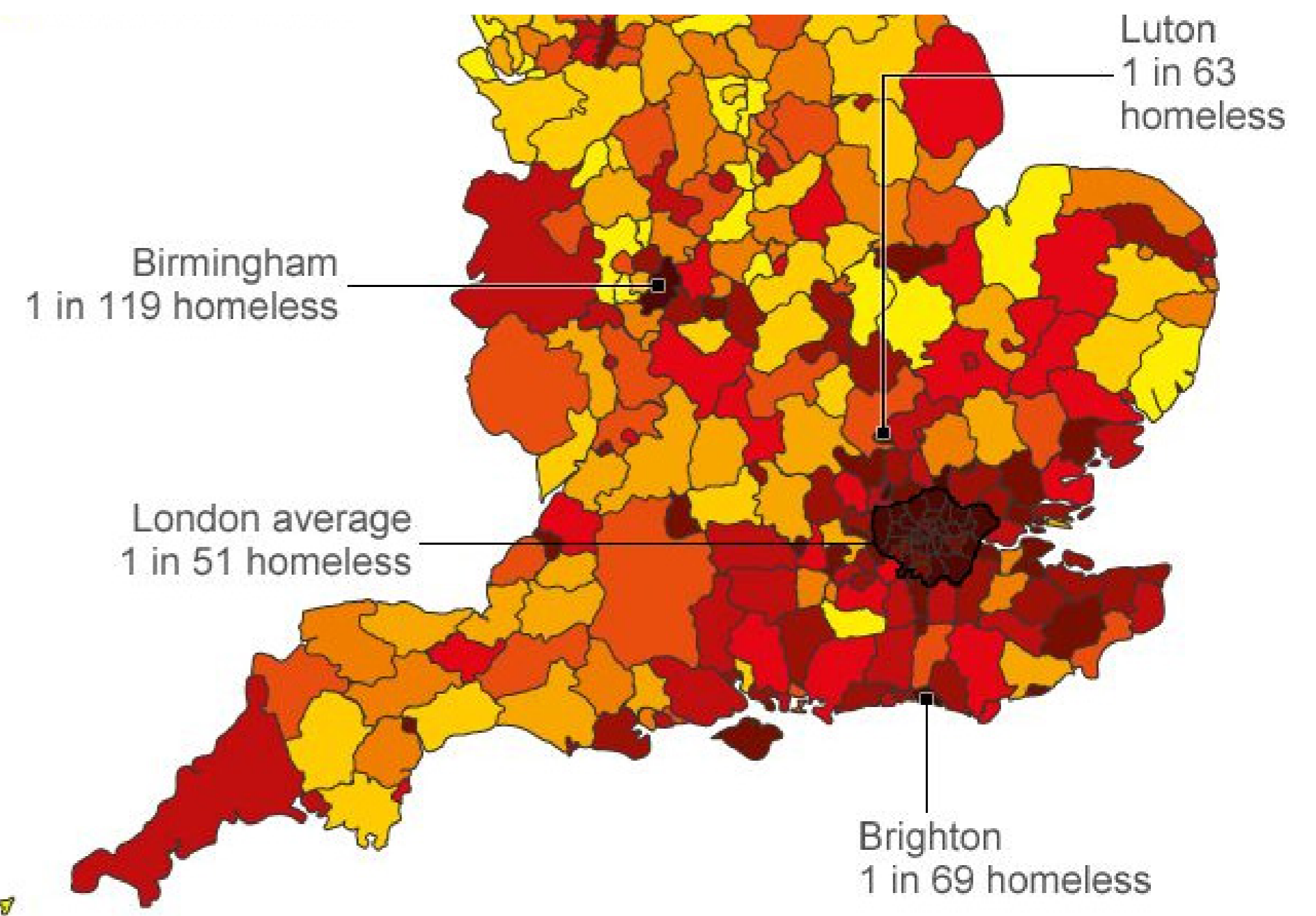

Created by Luis Iborra from Noun Project

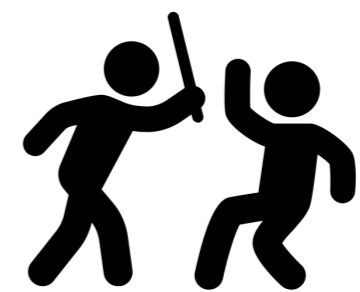
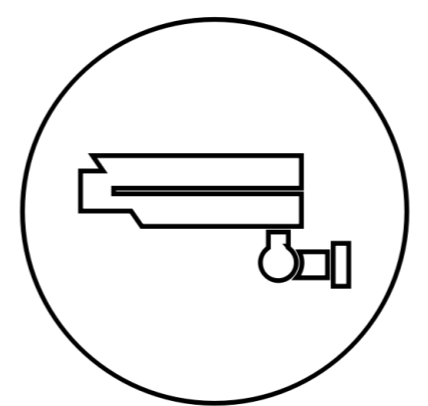

Created by Adrien Coquet from Noun Project

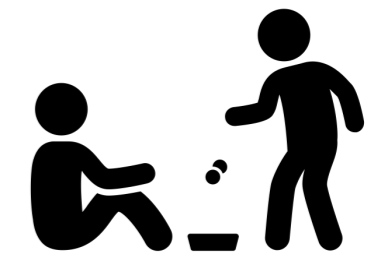

Created by Adrien Coquet from Noun Project

**SELF-DETERMINATION THEORY** ATTEMPTS TO SORT THROUGH THE MIX OF FACTORS THAT **MOTIVATE US INTRINSICALLY.**

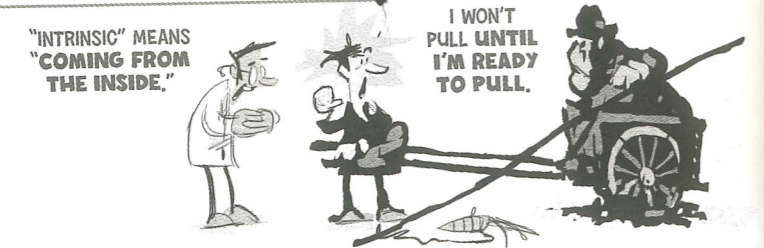

THE IDEA HERE IS THAT WE HAVE **THREE FUNDAMENTAL AIMS:**

WE ASPIRE TO **FORM STRONG SOCIAL BONDS...**

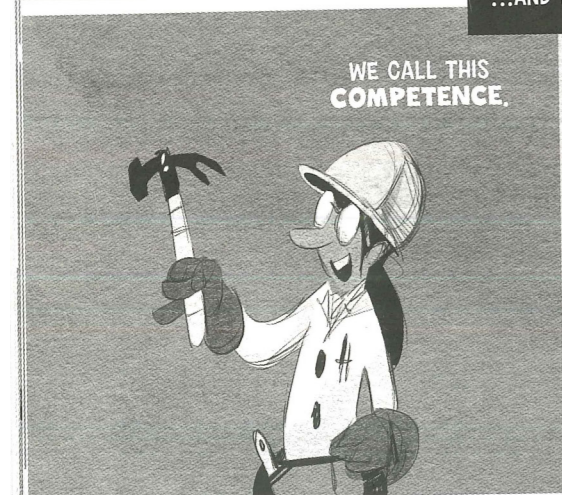
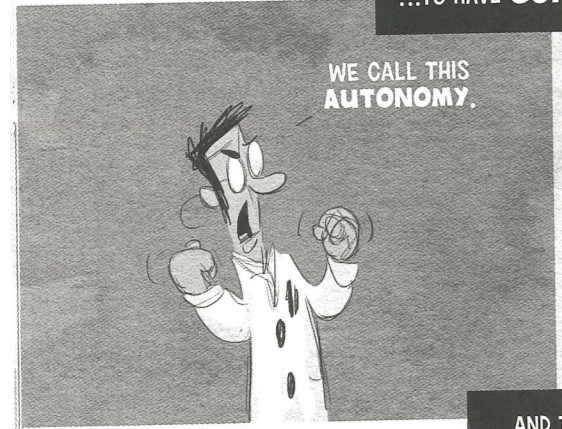
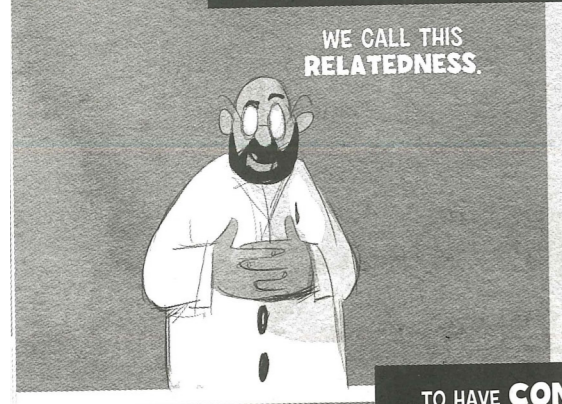

FOR EXAMPLE, WE'RE **MOST MOTIVATED** TO **LEARN SOMETHING** IF OUR **FRIENDS CARE** ABOUT IT...

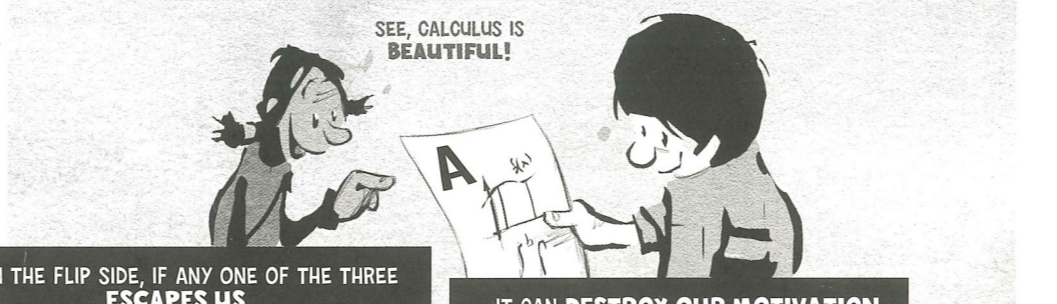
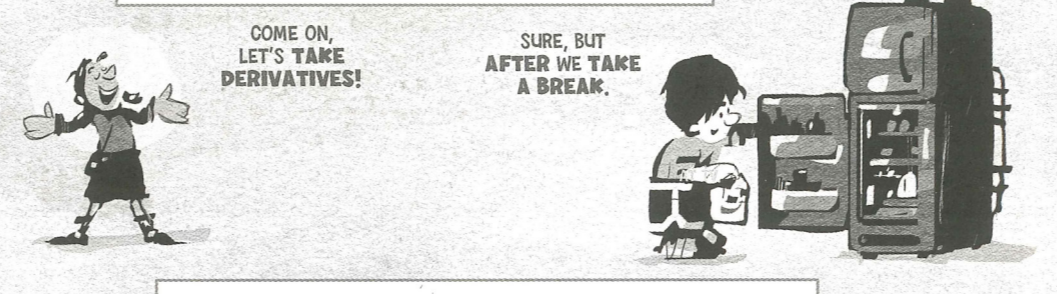

...IT CAN **DESTROY OUR MOTIVATION.**

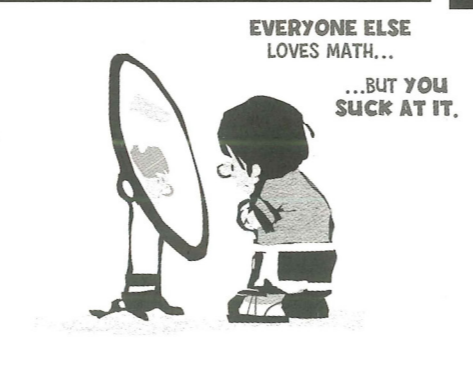

Let's do something!



**COMPETENCE**

**AUTONOMY**

**RELATEDNESS**

I can't be bothered...





The ignored population



The demonized population



Depending on charity for every aspect of their life

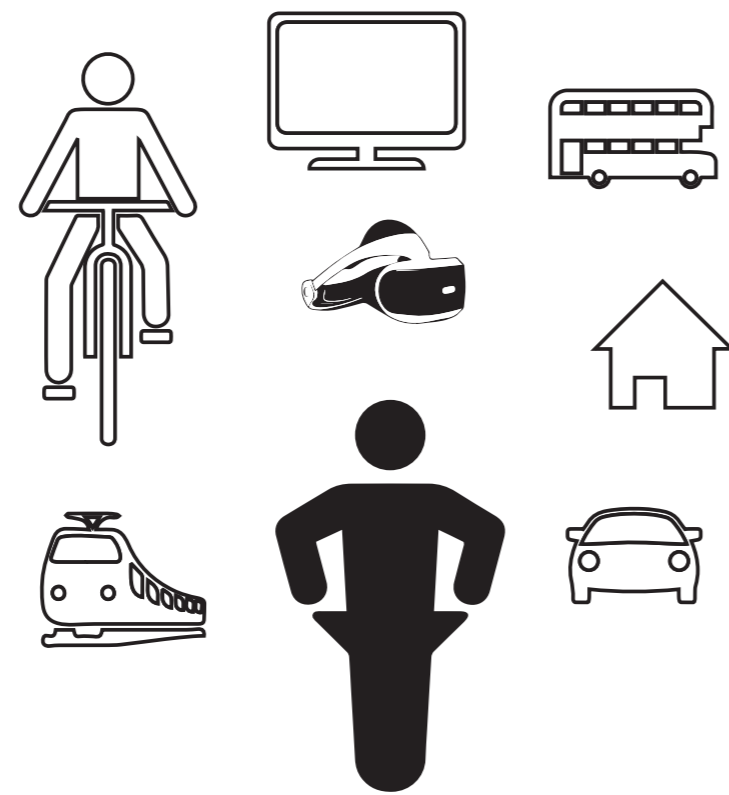

No means for technologically mediated experiences



Hyper-local stakeholders







Formal sleeping spaces and hygiene amenities

Responsibility

Shared food courts

Responsibility = Autonomy

Oi! Can  
ye clean up  
yer own  
skid marks?!





Mingling = relatedness



**NOT**  
The ignored population











podtime  
Rest. Ea





at the City's heart  
**CHEAPSIDE**

- TODAY

2017: KATVR in final stages of development  
2017: Gloveone in final stages of development  
2017: Teslasuit in final stages of development

2019: Facebook launches VR chatroom  
2020: First VR open world game

First companies start employing VR meetings  
City simulations become bigger, are actively marketed by travel agencies  
2021: Screen technology improves beyond pixels

Companies buy VR sets in lieu of all overseas meetings

2022: Launch of commercial full VR set

Trading floors have either been fully automated or are one international/digital place

2037: People simulations are optimized



# SYNTHESIS

## SIM-BODIED PRESENCE



Basic      Immersive      Intuitive      Full experience

£      £££      ££      £££



PHYSICAL distance is meaningless, SIMULATED distance meaningful



OVERLAY: the space of interaction exists ON TOP OF a PRIVATE space

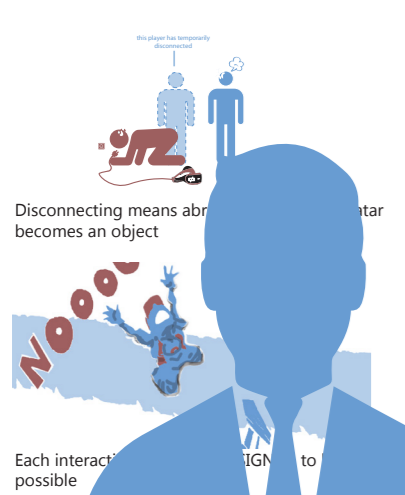

Disconnecting means avatar becomes an object

Each interaction possible



We connect to the avatar

Locating avatars are private

## Concrete abstraction



## Encountering a cross-section of humanity



## Privacy, anonymity, removed security

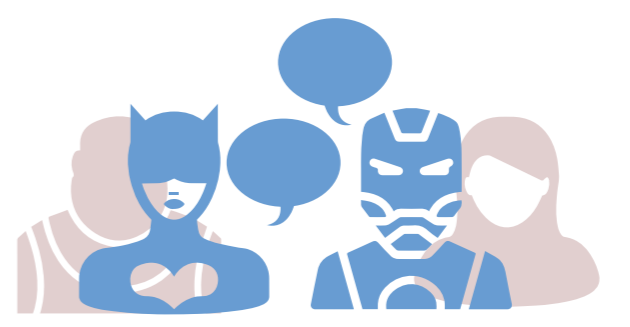

## Segregation by technology mediated actions



*An analogue urban strategy is necessary to  
strengthen our digital futures*





# *THANK YOU*

**STEFAN VAN DER SPEK, STEPHEN READ, ROBERTO CAVALLO, LUISA CALABRESE, ANGELO VERMEULEN, THOMAS MEIJER, MOLLY QUELL AND THE DELFT WRITING GROUP, FRIENDS AND FAMILY, MY FELLOW HESIODOS BOARD MEMBERS, AND EVERYONE ELSE THAT HELPED ME ALONG.**





# PRIVATIZATION

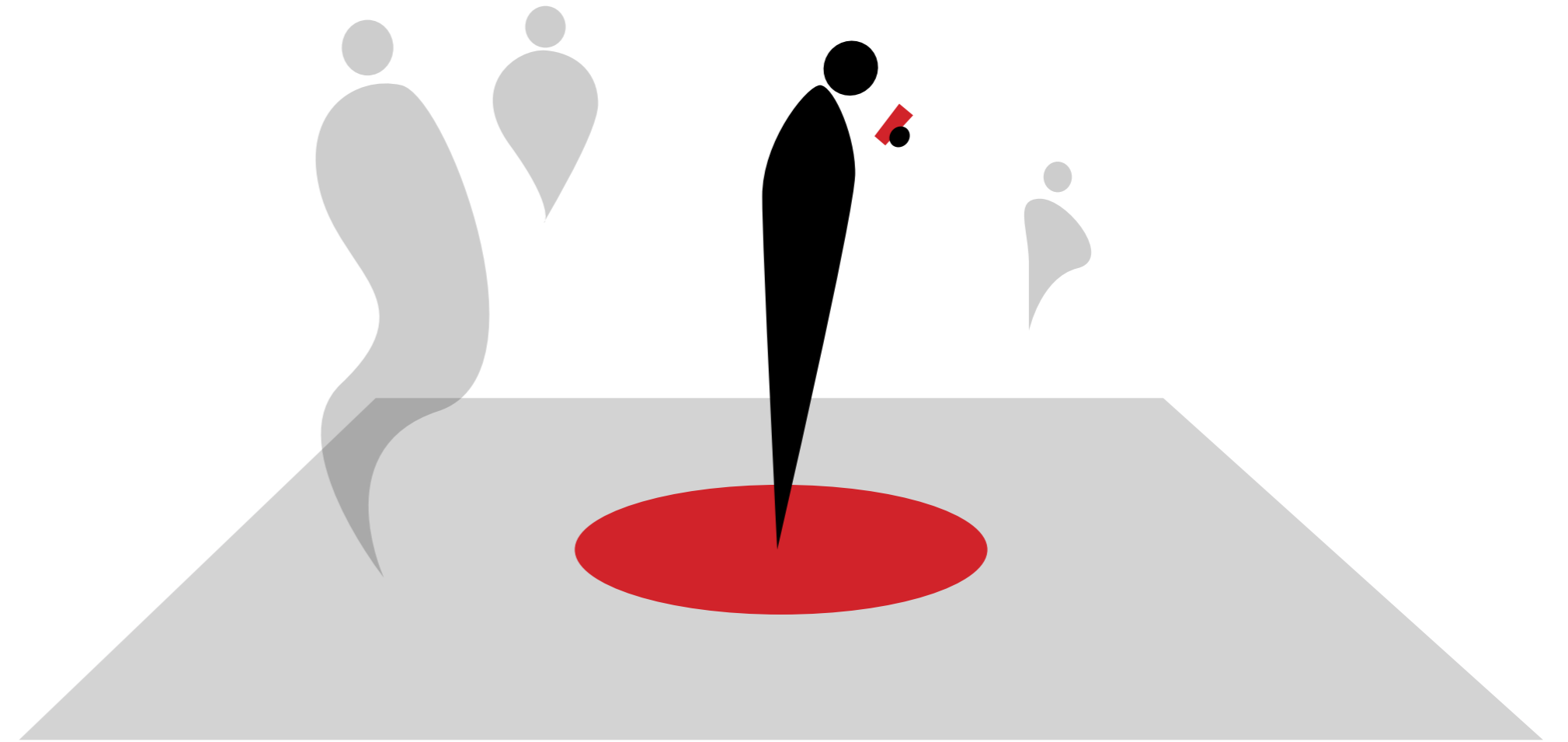

THROUGH THE PHONE, ONE CREATES A **PRIVATE** SPACE WHERE EVER THEY ARE

# SEPARATION

EMBODIED  $\neq$  LOCAL

ACCESS