

**Document Version**

Final published version

**Citation (APA)**

Eland, E., Karmakar, S., Gönen, B., Veldhoven, R. V., & Makinwa, K. (2020). A 440 $\mu$ W, 109.8dB DR, 106.5dB SNDR Discrete-Time Zoom ADC with a 20kHz BW. In *2020 IEEE Symposium on VLSI Circuits: Proceedings* (pp. 1-2). Article 9162856 IEEE. <https://doi.org/10.1109/VLSICircuits18222.2020.9162856>

**Important note**

To cite this publication, please use the final published version (if applicable).  
Please check the document version above.

**Copyright**

In case the licence states "Dutch Copyright Act (Article 25fa)", this publication was made available Green Open Access via the TU Delft Institutional Repository pursuant to Dutch Copyright Act (Article 25fa, the Taverne amendment). This provision does not affect copyright ownership.  
Unless copyright is transferred by contract or statute, it remains with the copyright holder.

**Sharing and reuse**

Other than for strictly personal use, it is not permitted to download, forward or distribute the text or part of it, without the consent of the author(s) and/or copyright holder(s), unless the work is under an open content license such as Creative Commons.

**Takedown policy**

Please contact us and provide details if you believe this document breaches copyrights.  
We will remove access to the work immediately and investigate your claim.

***Green Open Access added to TU Delft Institutional Repository***

***'You share, we take care!' - Taverne project***

**<https://www.openaccess.nl/en/you-share-we-take-care>**

Otherwise as indicated in the copyright section: the publisher is the copyright holder of this work and the author uses the Dutch legislation to make this work public.

# A 440 $\mu$ W, 109.8dB DR, 106.5dB SNDR Discrete-Time Zoom ADC with a 20kHz BW

Efraïm Eland<sup>1</sup>, Shoubhik Karmakar<sup>1</sup>, Burak Gönen<sup>1,2</sup>, Robert van Veldhoven<sup>3</sup>, Kofi Makinwa<sup>1</sup>

<sup>1</sup>Delft University of Technology, Delft, The Netherlands, <sup>2</sup>Ethernovia, Zeist, The Netherlands,

<sup>3</sup>NXP Semiconductors, Eindhoven, The Netherlands

## Abstract

This paper presents a discrete-time (DT) zoom ADC for audio applications. A 2b quantizer in combination with a low power “fuzz” suppression technique, results in a significant improvement in linearity and energy-efficiency over previous designs. The ADC occupies 0.27mm<sup>2</sup> in 0.16 $\mu$ m CMOS and consumes 440 $\mu$ W from a 1.8V supply. In a 20kHz BW, it achieves 109.8dB DR and 106.5dB SNDR, resulting in a state-of-the-art Schreier FoM of 186.4dB.

## Introduction

Zoom ADCs use a coarse low power SAR ADC to dynamically update the references of a Delta-Sigma Modulator ( $\Delta\Sigma$ ), resulting in both high dynamic range (DR) and energy-efficiency [1,3]. These characteristics make them well suited for use in audio applications. To accommodate SAR non-idealities, previous designs employed 1b  $\Delta\Sigma$ s and over-ranging, resulting in a significant loss of SQNR. They also suffered from extra in-band distortion or “fuzz” due to the leakage of SAR quantization noise ( $Q_{SAR}$ ) [3]. In this work, the DR loss due to over-ranging is mitigated by the use of a 2b  $\Delta\Sigma$ , which also enables a significant reduction in over-sampling ratio (OSR), and thus in digital power. Furthermore, a low power fuzz suppression technique is proposed, which significantly suppresses in-band distortion.

## Proposed Zoom ADC Architecture

Fig. 1 shows the proposed DT zoom ADC. It consists of a 5b asynchronous SAR ADC and a 3<sup>rd</sup> order feedforward  $\Delta\Sigma$ . The SAR ADC has a quantization step of  $V_{LSB-C}$  and outputs a digital code ( $k$ ), which satisfies  $k \cdot V_{LSB-C} < V_{IN} < (k+1) \cdot V_{LSB-C}$ . This is used to set the references of the  $\Delta\Sigma$ , such that  $V_{REF+} = (k+1+M) \cdot V_{LSB-C}$  and  $V_{REF-} = (k-M) \cdot V_{LSB-C}$ , where the over-ranging step  $M = 1$  confers robustness to SAR errors and to mismatch between the SAR and  $\Delta\Sigma$  quantization levels.

The DAC of a 1b  $\Delta\Sigma$  would then span  $3 \cdot V_{LSB-C}$ , wasting SQNR (Fig. 2a) [1,3]. In contrast, the output of a 2b  $\Delta\Sigma$   $Y_{\Delta\Sigma}$  uses all the SAR levels, i.e.  $(k+\{-1,0,1,2\}) \cdot V_{LSB-C}$  (Fig. 2b). This increases SQNR by 9 dB and enables lower OSR.

At low OSR, however,  $Q_{SAR}$  leakage will cause significant in-band distortion. From [3], the zoom ADC’s output can be expressed as  $D_{out} = k + Y_{\Delta\Sigma} = V_{IN} + Q_{\Delta\Sigma} \cdot NTF + Q_{SAR} (STF - I)$ . At high frequencies, the STF of a feedforward modulator will deviate from unity, resulting in  $Q_{SAR}$  leakage. Although this can be corrected in the digital domain, the required reconstruction filter is quite complex [3]. In this work, a unity STF is achieved by using a feedforward path to inject a replica of  $Q_{SAR}$  into the loop filter just before the quantizer (Fig. 1).

Fig. 3 shows a simplified schematic of the zoom ADC. At the onset of  $\Phi_1$ , the SAR ADC samples  $V_{IN}$  and converts it into a 5b output ( $k$ ) with negligible delay. During  $\Phi_1$ , OTA<sub>1</sub> is disconnected from the loop filter, configured in unity gain and then chopped, which mitigates its offset and 1/f noise. Since there is now no signal content at its input, this approach eliminates chopping artefacts. At the end of  $\Phi_1$ , the  $\Delta\Sigma$  samples  $V_{IN}$  onto the sampling capacitors  $C_{S1-P}$  and  $C_{S1-M}$  in a fully differential manner, thereby rejecting any CM input.  $C_{S1-P}$

and  $C_{S1-M}$ , each consisting of 31 unit elements sized for thermal noise (13.6pF in total), also serve as the feedback CDACs. Their  $\sim$ 13b inherent linearity is significantly improved by using DWA. During  $\Phi_2$ , the unit elements of the DAC are driven by a 31b unary signal, which is pre-calculated during  $\Phi_1$  by combining  $k$  and  $Y_{\Delta\Sigma}$ . The result is then integrated on  $C_{INT1}$  (9.1pF). The capacitors of the 2<sup>nd</sup> and 3<sup>rd</sup> stage are sized for mismatch, as their noise contribution is negligible. To maximize the modulator’s SQNR,  $C_{notch}$  creates an NTF notch by establishing a resonant feedback path around the 1<sup>st</sup> and 2<sup>nd</sup> integrators. The use of zooming and a 2b quantizer means that the internal loop filter swings are quite small, and so all three stages are built around energy-efficient, high PSRR, current-starved OTAs [3].

The 2b flash-based quantizer consists of a resistive reference ladder ( $R_u = 72k\Omega$ ) and three comparators (Fig. 4). The top and bottom comparators employ continuous-time pre-amps to minimize kickback to the reference ladder, while the mid-level comparator uses a dynamic pre-amp to minimize power consumption, since its kickback will be absorbed by OTA<sub>3</sub> and is mainly CM in nature. To increase the output swing of the loop filter and thus relax the requirements on comparator offset, the threshold voltages are set such that the quantizer gain  $K_Q$  is small ( $\sim 1/4$ ). The feedforward path is implemented by replicating  $Q_{SAR}$  with a separate input feedforward capacitor  $C_{inFF}$  and a 5b CDAC  $C_{resDAC}$ , also controlled by  $k$ . The capacitor values are sized to implement the optimal feedforward path gain  $G = 1/K_Q$  (Fig. 1).

## Measurement results

The zoom ADC occupies 0.27mm<sup>2</sup> in a 0.16 $\mu$ m CMOS technology, (Fig. 5). At a sampling frequency  $f_s$  of 3.5MHz ( $OSR = 87.5$ ) it consumes 440 $\mu$ W from a 1.8V supply (46% analog, 19% DAC and 35% digital circuits). Fig. 6 shows the output spectrum with shorted inputs. Chopping at  $f_{chop} = f_s/2$  reduces the 1/f corner to  $< 10$ Hz without impacting the noise floor. Fig. 7 shows the ADC’s output spectrum for a -0.5dBFS input at 1kHz. Turning the fuzz suppression scheme “ON” results in a 7.4dB and 2.9dB improvement in THD and peak SNDR, respectively, which is mainly limited by the mismatch between the SAR and feedforward CDACs and by the  $\Delta\Sigma$ ’s residual non-linearity. The measured peak SNR, SNDR, and DR of the zoom ADC are 107.5dB, 106.5dB, and 109.8dB, respectively (Fig. 8). Over the audio band, the measured CMRR is greater than 89dB for a full-swing CM input (Fig. 9). The measured PSRR is 99.2dB at 50Hz, and it remains above 97dB over the audio band (Fig. 9). Fig. 10 shows the total in-band integrated noise in the presence of large (-1.5dBFS) input signals. The ADC is robust to signals up to 80kHz, which is some 3x better than a previous zoom ADC [1]. Table I summarizes the ADC’s performance and compares it to the state-of-the-art. This work achieves a  $FoM_{S,DR}$  of 186.4dB and  $FoM_{SNDR}$  of 183.1dB, which represent the highest energy-efficiency published to date for audio ADCs.

## References

- [1] B. Gönen, *et al.*, *JSSC*, 2019
- [2] C. Lee, *et al.*, *JSSC*, 2019
- [3] S. Karmakar, *et al.*, *JSSC*, 2018
- [4] S. Billa, *et al.*, *JSSC*, 2017

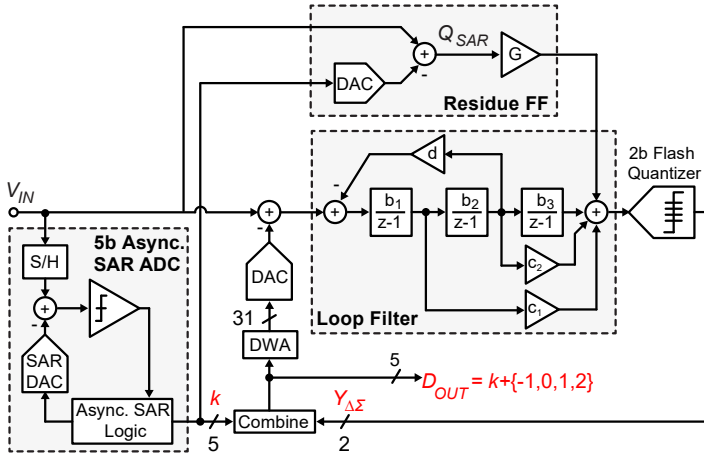

Fig. 1: Proposed DT zoom ADC

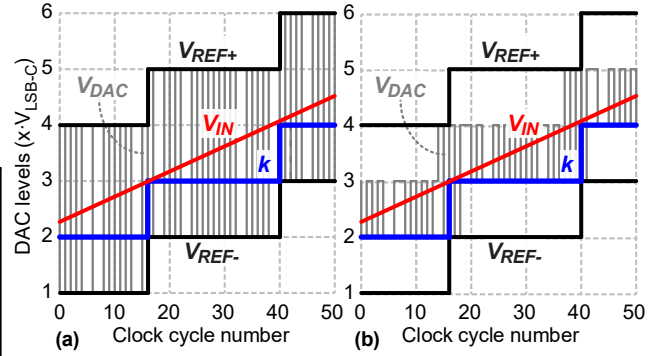

Fig. 2: SAR output ( $k$ ) and  $\Delta\Sigma$  DAC swings with  $M = 1$  for (a) a 1b quantizer and (b) a 2b quantizer

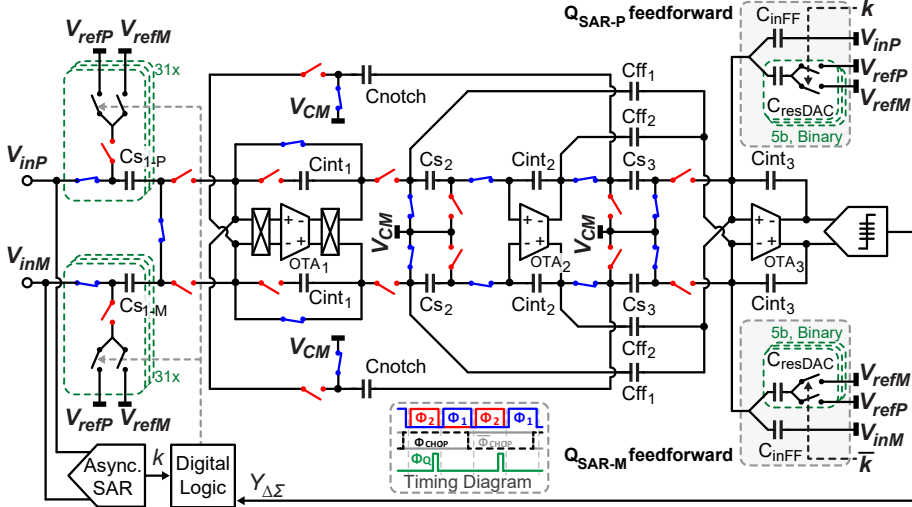

Fig. 3: Schematic of the proposed zoom ADC

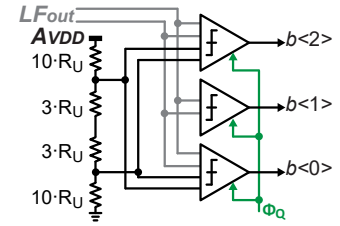

Fig. 4: 2b Flash quantizer

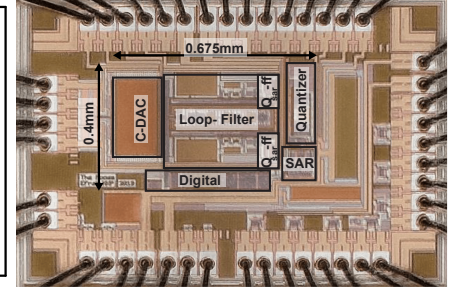

Fig. 5: Die micrograph

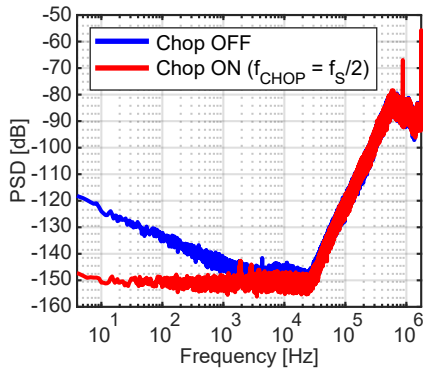

Fig. 6: Meas. PSD w/ and w/o chopping

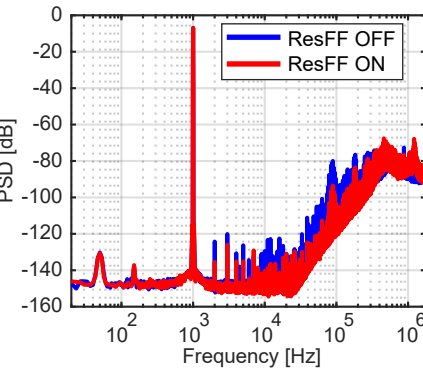

Fig. 7: Meas. PSD w/ and w/o  $Q_{SAR}$  ResFF

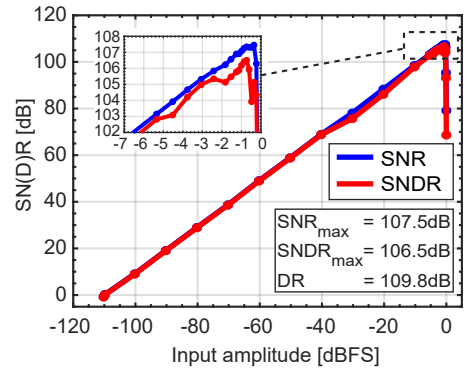

Fig. 8: Meas. SN(D)R across i/p amplitude

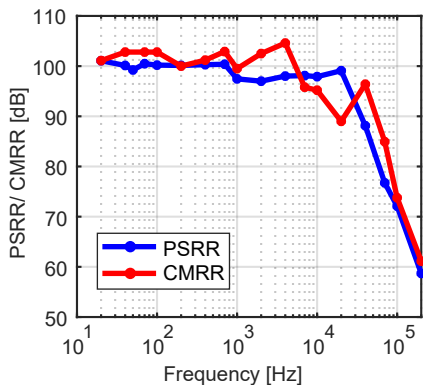

Fig. 9: Measured CMRR and PSRR across input/ supply frequency

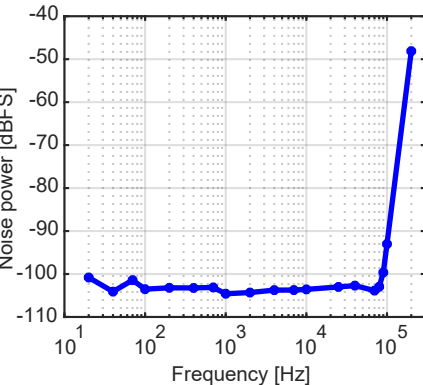

Fig. 10: Total in-band noise power across  $f_{IN}$  for a -1.5 dBFS input amplitude

Table 1. Performance summary and comparison

	This work	[1]	[2]	[3]	[4]
Tech (nm)	160	160	65	160	180
Area (mm <sup>2</sup> )	0.27	0.27	0.14	0.25	1
Supply (V)	1.8	1.8	1.2	1.8	1.8
Power ( $\mu$ W)	440	618	68	280	280
$f_s$ (MHz)	3.5	5.12	6.144	2	6.144
BW (kHz)	20	20	24	1	24
SNR <sub>max</sub> (dB)	107.5	108.1	94.8	119.1	99.3
SNDR <sub>max</sub> (dB)	106.5	106.4	94.1	118.1	98.5
DR (dB)	109.8	108.5	98.2	120.3	103.6
FoM <sub>SNDR</sub> <sup>*</sup> (dB)	183.1	181.5	179.5	183.6	177.8
FoM <sub>S</sub> <sup>**</sup> (dB)	186.4	183.6	183.6	185.8	182.9

\*  $FoM_{SNDR} = SNDR + 10\log_{10}(BW/Power)$  \*\*  $FoM_S = DR + 10\log_{10}(BW/Power)$