

**Artificial intelligence powered large-scale renewable integrations in multi-energy systems for carbon neutrality transition**

**Challenges and future perspectives**

Liu, Zhengxuan; Sun, Ying; Xing, Chaojie; Liu, Jia; He, Yingdong; Zhou, Yuekuan; Zhang, Guoqiang

**DOI**

[10.1016/j.egyai.2022.100195](https://doi.org/10.1016/j.egyai.2022.100195)

**Publication date**

2022

**Document Version**

Final published version

**Published in**

Energy and AI

**Citation (APA)**

Liu, Z., Sun, Y., Xing, C., Liu, J., He, Y., Zhou, Y., & Zhang, G. (2022). Artificial intelligence powered large-scale renewable integrations in multi-energy systems for carbon neutrality transition: Challenges and future perspectives. *Energy and AI*, 10, Article 100195. <https://doi.org/10.1016/j.egyai.2022.100195>

**Important note**

To cite this publication, please use the final published version (if applicable). Please check the document version above.

**Copyright**

Other than for strictly personal use, it is not permitted to download, forward or distribute the text or part of it, without the consent of the author(s) and/or copyright holder(s), unless the work is under an open content license such as Creative Commons.

**Takedown policy**

Please contact us and provide details if you believe this document breaches copyrights. We will remove access to the work immediately and investigate your claim.

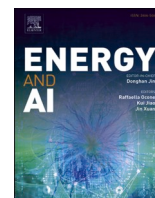

## Review

# Artificial intelligence powered large-scale renewable integrations in multi-energy systems for carbon neutrality transition: Challenges and future perspectives

Zhengxuan Liu<sup>a,b,\*</sup>, Ying Sun<sup>c,\*</sup>, Chaojie Xing<sup>a</sup>, Jia Liu<sup>d,e,f</sup>, Yingdong He<sup>a</sup>, Yuekuan Zhou<sup>g,h,i,\*</sup>, Guoqiang Zhang<sup>a</sup>

<sup>a</sup> College of Civil Engineering, National Center for International Research Collaboration in Building Safety and Environment, Hunan University, Changsha, 410082, China

<sup>b</sup> Faculty of Architecture and the Built Environment, Delft University of Technology, Julianalaan 134, 2628 BL, Delft, Netherlands

<sup>c</sup> Energy and Environment Group, Department of Building, Civil and Environmental Engineering, Concordia University, Montreal, Canada

<sup>d</sup> College of Civil Engineering, Guangzhou University, Guangzhou, China

<sup>e</sup> Department of Building Environment and Energy Engineering, The Hong Kong Polytechnic University, Kowloon, Hong Kong, China

<sup>f</sup> Guangdong Provincial Key Laboratory of Building Energy Efficiency and Application Technologies, Guangzhou University, Guangzhou, China

<sup>g</sup> Sustainable Energy and Environment Thrust, Function Hub, The Hong Kong University of Science and Technology (Guangzhou), Nansha, 511400, Guangdong, China

<sup>h</sup> Department of Mechanical and Aerospace Engineering, The Hong Kong University of Science and Technology, Clear Water Bay, Hong Kong Special Administrative Region, China

<sup>i</sup> HKUST Shenzhen-Hong Kong Collaborative Innovation Research Institute, Shenzhen, China



## HIGHLIGHTS

- Functional contributions of AI techniques for large-scale renewable energy integrations were discussed.
- Practical applications and effectiveness of various AI techniques were analyzed.
- Limitations and challenges associated with large-scale renewable energy integrations using AI techniques were summarized.
- Some promising research perspectives and recommendations were proposed.

## ARTICLE INFO

## Keywords:

Artificial intelligent techniques  
Renewable energy  
Large-scale integration  
Energy transition  
Carbon neutrality

## ABSTRACT

The vigorous expansion of renewable energy as a substitute for fossil energy is the predominant route of action to achieve worldwide carbon neutrality. However, clean energy supplies in multi-energy building districts are still at the preliminary stages for energy paradigm transitions. In particular, technologies and methodologies for large-scale renewable energy integrations are still not sufficiently sophisticated, in terms of intelligent control management. Artificial intelligent (AI) techniques powered renewable energy systems can learn from bio-inspired lessons and provide power systems with intelligence. However, there are few in-depth dissections and deliberations on the roles of AI techniques for large-scale integrations of renewable energy and decarbonisation in multi-energy systems. This study summarizes the commonly used AI-related approaches and discusses their functional advantages when being applied in various renewable energy sectors, as well as their functional contribution to optimizing the operational control modalities of renewable energy and improving the overall operational effectiveness. This study also presents practical applications of various AI techniques in large-scale renewable energy integration systems, and analyzes their effectiveness through theoretical explanations and diverse case studies. In addition, this study introduces limitations and challenges associated with the large-scale renewable energy integrations for carbon neutrality transition using relevant AI techniques, and proposes further promising research perspectives and recommendations. This comprehensive review ignites advanced AI techniques for large-scale renewable integrations and provides valuable informational instructions and guidelines to different stakeholders (e.g., engineers, designers and scientists) for carbon neutrality transition.

\* Corresponding authors.

E-mail addresses: [Z.liu-12@tudelft.nl](mailto:Z.liu-12@tudelft.nl) (Z. Liu), [sunyingca95@gmail.com](mailto:sunyingca95@gmail.com) (Y. Sun), [yuekuanzhou@ust.hk](mailto:yuekuanzhou@ust.hk), [yuekuan.zhou@outlook.com](mailto:yuekuan.zhou@outlook.com) (Y. Zhou).

<https://doi.org/10.1016/j.egyai.2022.100195>

Received 4 July 2022; Received in revised form 2 August 2022; Accepted 2 August 2022

Available online 5 August 2022

2666-5468/© 2022 The Author(s). Published by Elsevier Ltd. This is an open access article under the CC BY license (<http://creativecommons.org/licenses/by/4.0/>).

## 1. Introduction

The use of conventional energy systems (e.g., coal, oil and natural gas) has caused a dramatic rise in CO<sub>2</sub> emissions and resulted in global warming [1–3]. The global energy and environmental issues necessitate the deployment of large-scale renewable energy. Nowadays, renewable energy generation (especially solar and wind energy) has attracted considerable attention and large-scale application as the most common technologies to mitigate energy and environmental issues [4–6]. However, solar and wind power generation technologies suffer from intermittency and difficulty in continuity [7–9]. This intermittent availability of power output has important implications for the grid system, such as voltage fluctuations, frequency fluctuations, reactive power, system outages, and frequent switching of electrical equipment, as well as for forecasting and scheduling, load management, and storage system [10, 11]. Large-scale renewable energy generations could lead to voltage increases in the grid, which are significant in the scenario of grid-connected photovoltaic (PV) generation [12]. In addition, the intermittent availability of solar energy could lead to non-uniform power generation, and therefore may overload the capabilities of the connected transformers, also potentially lead to grid-wide phase imbalances [13–15].

Currently, solar and wind generations have become an essential part of smart grids, smart microgrids and smart buildings, which account for an increasing sharing proportion in electricity supply [16, 17]. Nevertheless, due to the high-randomness, low-predictability and intermittent characteristics of solar and wind energy, reliability and security of large-scale grid-connected renewable energy systems (RES) have been regarded as most critical issues that need to be addressed [18, 19]. Therefore, using intelligent techniques to dispatch, manage and optimize renewable energy sources will be a required effective measure to stabilize the grid power and ensure power supply security in electricity grids [20]. Intelligent techniques, e.g., artificial intelligence (AI), are powerful tools that could address the complexity of the global energy transition, improve system effectiveness, reduce costs and accelerate the speed of decarbonization transition [21, 22]. They are primarily applied to renewable energy generation and demand forecasting, grid operation optimization, and energy demand management [23, 24].

Numerous researchers have investigated the integrated applications of AI techniques with renewable energy, including wind and solar complementary power generation, wind power access to electric grid system, and solar storage distribution network [25, 26]. The emergence of AI techniques has brought new opportunities for renewable energy dissipation, grid frequency regulation and peak shaving, which enables the smooth connection of renewable electricity generation to the grid [27]. Hua et al. [28] indicated that AI technique was one of the optimal operational control strategies to underpin electric power systems. Their study attempted to address how AI techniques could be incorporated into the smart grid to facilitate professional consumers' participation in the energy market. To achieve this goal, they reviewed how policy design could be designed to put a price on CO<sub>2</sub> emissions resulting from fossil fuel-based electricity generation to encourage the integration of professional consumers with renewables. Then, they discussed how AI techniques could strengthen condition monitoring and determination during electricity power system operations. Ghadami et al. [29] proposed a smart city conceptualization using AI and renewable energy, e.g., PV technologies. The study aimed to assess the electrical energy consumption in Mashhad region of Iran using machine-learning-based tools and proposed a dynamical strategy to increase citizens' willingness to generate electricity from renewables based on expert knowledges. Results showed that an artificial neural network model could successfully predict the overall electrical power consumption during summer and winter with an accuracy of 99%. Then, according to the calculations in the PV system for solar energy, the peaks of electrical power consumption can be controlled during the hottest and coldest months. Abdalla et al. [24] comprehensively overviewed the

integrations of RES and energy storage systems (ESS) considering AI techniques. This study summarized the functions, classification, design optimization approaches and applications of EES in electric power systems based on the technical characteristics of RES. Also, applications of AI techniques in optimizing system configuration, energy control strategies and applicability of different EES are also thoroughly sorted out, which provided new inspirations and conceptions for the future research perspectives of large-scale integrated ESS.

The coexistence of renewable energy and carbon capture presents a new pathway where the deployment of carbon capture can provide additional flexibility to preferably accommodate renewable energy, meanwhile the surplus renewable energy can be used to reduce the operation cost of carbon capture [30, 31]. Chen et al. [32] proposed an AI-based optimization scheduling strategy for power plants and carbon capture systems in terms of renewable energy penetration to show that co-benefits between carbon capture and renewable energy generation can be achieved when the carbon capture process was fully adjustable. A deeply believed neural network with AI was used to reflect the complex interactions between carbon, heat and electricity within the carbon capture system of the power plant. Multiple operational objectives, such as operating cost minimization, renewable power reduction, and carbon emissions, were considered within the scheduling, and a particle swarm heuristic optimization approach was used to find the best solution.

Based on the above-mentioned comprehensive summarizations and explanations, it can be seen that the vigorous expansion of RES as a substitute for fossil energy is the predominant route of action to achieve worldwide carbon neutrality at current periods [33–35]. However, the application of RES in the overall energy supply network is still in the preliminary stage of energy transition. In particular, the integrated technologies and methods for large-scale renewable energy applications are still not mature enough [36, 37]. Besides, the intermittent of commonly used RES (e.g., solar and wind energy) leads to difficulties in matching energy production, supply and utilization, and thus the practical operational effectiveness of these systems would be seriously undermined [38, 39]. To solve this problem, integrating AI techniques into RES can be considered as a recommendable option in practical applications [40]. The integration of AI techniques with RES has received a considerable attention in recent years, and a large number of studies have been carried out from different perspectives. For instance, Milidonis et al. [41] presented a detailed overview on the applications of AI techniques for analysis, design, optimization, control, operation and maintenance of solar tower systems. Al-Othman et al. [42] comprehensively reviewed the applications of AI techniques in hybrid renewable energy systems (HRES), especially solar PV and wind energy integrated with fuel cells. This study further clarified that the main advantages of AI solutions revolved around predicting the drawbacks of HRES during peak load periods as well as intermittent energy generation. However, there are few in-depth dissections and deliberations on the roles of AI techniques for large-scale integration of RES applications in different scenarios. Large-scale integration of renewable energy is distinguished from conventional RES, which typically possess more complex system integration and control strategies. In addition, there is still a lack of a comprehensive summarization and analysis on the up-to-date research status, existing issues and faced challenges of AI techniques in large-scale RES applications for carbon neutrality transition.

To solve above-mentioned scientific gaps, this study will conduct a systematic overview on AI techniques in large-scale RES applications to provide cutting-edge guidance and energy planning strategies for relevant stakeholders, especially the formulation of relevant energy policies and blueprint initiatives. In this study, the commonly used approaches, advantages and functional roles of intelligent techniques in various RES sectors are summarized, as well as their functional contribution to optimizing operational control modalities of RES and improving the overall operational effectiveness of these systems. Furthermore, this study presents the practical applications of various AI techniques in

large-scale renewable energy integration systems, and analyzes the effectiveness of these methodologies through theoretical explanations and diverse case studies. In addition, this study also analyzes the limitations and challenges associated with the large-scale integration of RES using the relevant AI techniques, as well as proposing further promising research perspectives and recommendations. This comprehensive overview demonstrates the contributions of advanced AI techniques to the large-scale integration application of RES and the corresponding subsequent development.

## 2. Common approaches, advantages and functional roles of AI techniques

### 2.1. Common AI-related approaches

With the rapid development of AI techniques, integrating AI technologies with large-scale RES utilizations has become an increasingly promising and imperative tendency. In general, AI techniques indicate the ability of one computer or machine to mimic human cognitive functions, e.g., learning and trouble-shooting abilities [41, 42]. They can be used for performance or property prediction, operational control, programming and optimization, etc. This section introduces some prevailing AI techniques, which are well-inspired by the human brains (e.g., artificial neural networks (ANN) and fuzzy logic) or animal behaviors (e.g., particle swarm optimization (PSO) and ant colony optimization (ACO)) [43].

#### 2.1.1. Artificial neural networks (ANN)

ANN is one of the most widely used AI techniques in various fields, such as renewable energy technologies (e.g., solar, wind, geothermal, etc.) [44], air-conditioning systems (e.g., load prediction, fault detection) [45, 46], etc. A typical ANN model is usually composed of the input layer, hidden layer and output layer. Each layer contains a group of neurons that use an activation function to calculate the output based on inputs from previous layers. The backward propagation (BP) algorithm is commonly used for ANN training to optimize the weights and biases of individual neurons. However, the optimal ANN structure, including the numbers of hidden layers and hidden neurons, and activation functions, are determined in most situations using trial-and-error methods [43].

In large-scale energy system optimizations, developing ANN-based agent models bypasses the use of computational extension models and

significantly minimizes the computational time of optimization tasks, compared with actual engineering models [47]. Some studies demonstrated that agent models using ANN could potentially increase the computational speed of system optimization by over 100 times, while achieving accuracy rates of up to 90% [48]. To achieve minimal environmental impacts and maximal economic benefits of HRES and to establish a trade-off between government and residents, Luo et al. [49] developed a new ANN-based hybrid algorithm (ABHA, whose workflow is shown in Fig. 1) to replace the lower-level optimization problems and transform the two-level optimization into a single-level optimization problem, thereby improving the computational efficiency. The results demonstrated that (i) ABHA can achieve high accuracy and significantly reduce the calculation time compared to traditional methods; (ii) Under the optimal subsidization policy, most of the energy requirements in the proposed stand-alone HRES can be fulfilled from solar energy; (iii) Increasing the subsidy would expand the scale-up PV installation and decrease the carbon emissions; however, the design and operation of the HRES would not be further compromised as the subsidy exceeds a certain threshold.

#### 2.1.2. Fuzzy logic control (FLC)

Fuzzy logic control (FLC) is a prevalent nonlinear and adaptive control technique that provides robust performance in the presence of parameter uncertainty. Fuzzy logic contributes to conceptualize the ambiguity in a system into clear quantifiable parameters [50]. Therefore, FLC-based models can be used for effective energy management planning, and thereby deriving practical solutions. In recent years, FLC-based inference systems have been widely used for solar PV control/smart grid systems. FLC algorithms are also utilized for solar PV/wind energy control systems and for finding the optimal topography for wind energy generation. Fuzzy expert systems and neuro-fuzzy expert systems are AI applications for identifying the optimal energy source or maximizing available resources [51].

FLC has numerous advantages over other classical expert systems due to the possibility of introducing multiple input variables in the controller structure with lower complexity [52]. In addition, the expected FLC performance can be easily described in a textual manner, which avoids the requirement for mathematical expressions for the entire input ranges. Vigneysh and Kumarappan [53] proposed a simple structure that exploited the robustness and adaptiveness of FLC and PI controller to effectively improve the dynamic performance of a grid

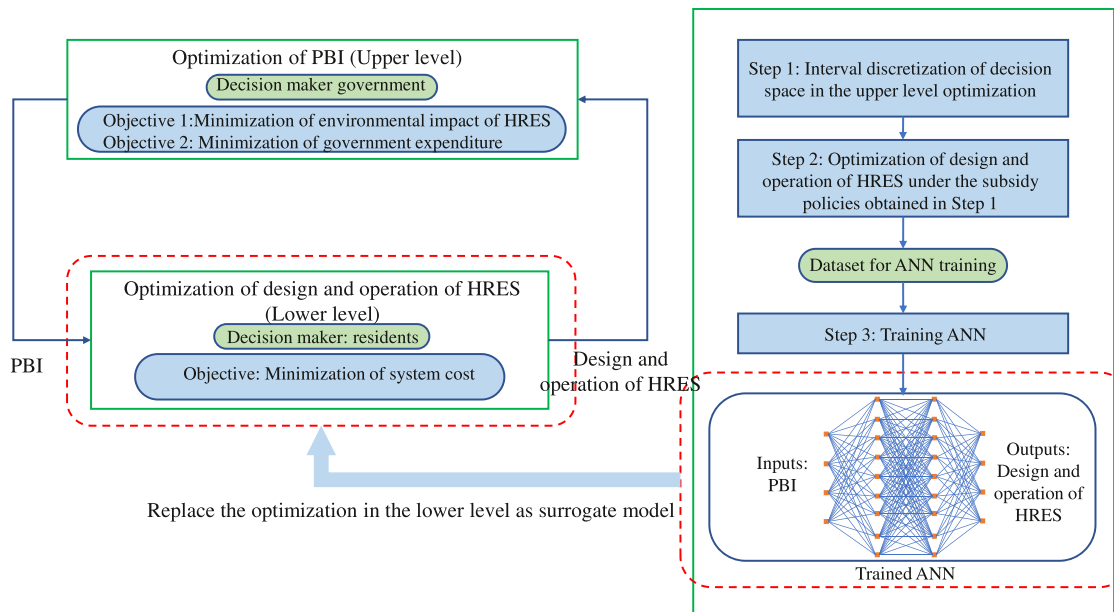

Fig. 1. Flowchart of the ANN-based Hybrid Algorithm (ABHA) [49].

interactive converter (GIC) under uncertainty. The input gain of the PI controller was dynamically adjusted by the operational conditions of the fuzzy logic-based supervisory control system. Thus, it provided fast dynamic response and reduced overshoot during perturbations. Cai et al. [54] determined the optimal strategy for energy management system planning under multiple uncertainties using a fuzzy stochastic interval programming model. This approach integrated interval linear programming, fuzzy stochastic programming, and mixed integer programming. Therefore, fuzzy logic could contribute to effectively capture and compress the data and uncertainties associated with energy modeling.

Athari and Ardehali [55] investigated the influences of time-varying electricity prices on the performances of energy storage components of a grid-connected hybrid renewable energy system (HRES) managed by a prediction-based optimization tuned FLC. The flowchart of the optimization procedure for FLC-managed grid-connected HRES energy storage component performance is shown in Fig. 2, where weekly and daily forecast data were used to determine the optimal affiliation function of the FLC. The predicted data included grid electricity prices, electrical loads and environmental parameters such as wind speed, solar radiation and ambient temperature. Simulation results demonstrated that the performances of energy storage modules for grid-connected HRES are strongly influenced by the grid electricity price. Optimization of FLC could decrease fluctuations and improve the average charge status, thereby extending the expected battery lifetime. When using grid-connected HRES, optimization of FLC based on shorter forecast periods was preferred due to the fact that shorter forecast periods would result in more accurate data predictions, and not result in more than one-day FLC adjustments being its optimal performance.

### 2.1.3. Particle swarm optimization (PSO)

The PSO algorithm is a population-based optimization method inspired by the social behavior of bird and fish flocks searching for food, which means that individuals in a group move to good regions based on their adaptation to the environment [56]. The dimensionality of the particles is determined by the number of variables in each question, and the quality of the solutions for each particle is measured by the fitness function. It is commonly considered that PSO is one type of cluster intelligence, which can be incorporated into a multi-subject optimization system [57, 58]. There are various upgraded PSO algorithms in practical applications, such as evolutionary particle swarm optimization (EPSO) algorithm, quantum-behaved particle swarm optimization (QPSO) algorithm, and chaotic Darwinian particle swarm optimization (CDPSO) algorithm, etc.

García-Triviño et al. [59] investigated a PSO-based PI controller for the power control of a grid-connected inverter powered by a HRES that is composed of two renewable energy sources (wind turbine and photovoltaic-PV-solar panel) and two ESS (battery and hydrogen system, integrated by fuel cell and electrolyzer). Fig. 3 illustrates the control scheme of the PSO-based on-line PI controller. Three PSO-based PI controllers are implemented: 1) a conventional PI controller with offline tuning of the PSO algorithm based on the absolute error index of the integration time; 2) a PI controller with online self-tuning of the PSO algorithm based on the error; 3) a PI controller with online self-tuning of the PSO algorithm based on the absolute error index of the integration time.

LoRESTANI and Ardehali [60] investigated the optimal integration of cooling, heating, and power trigeneration renewable energy sources

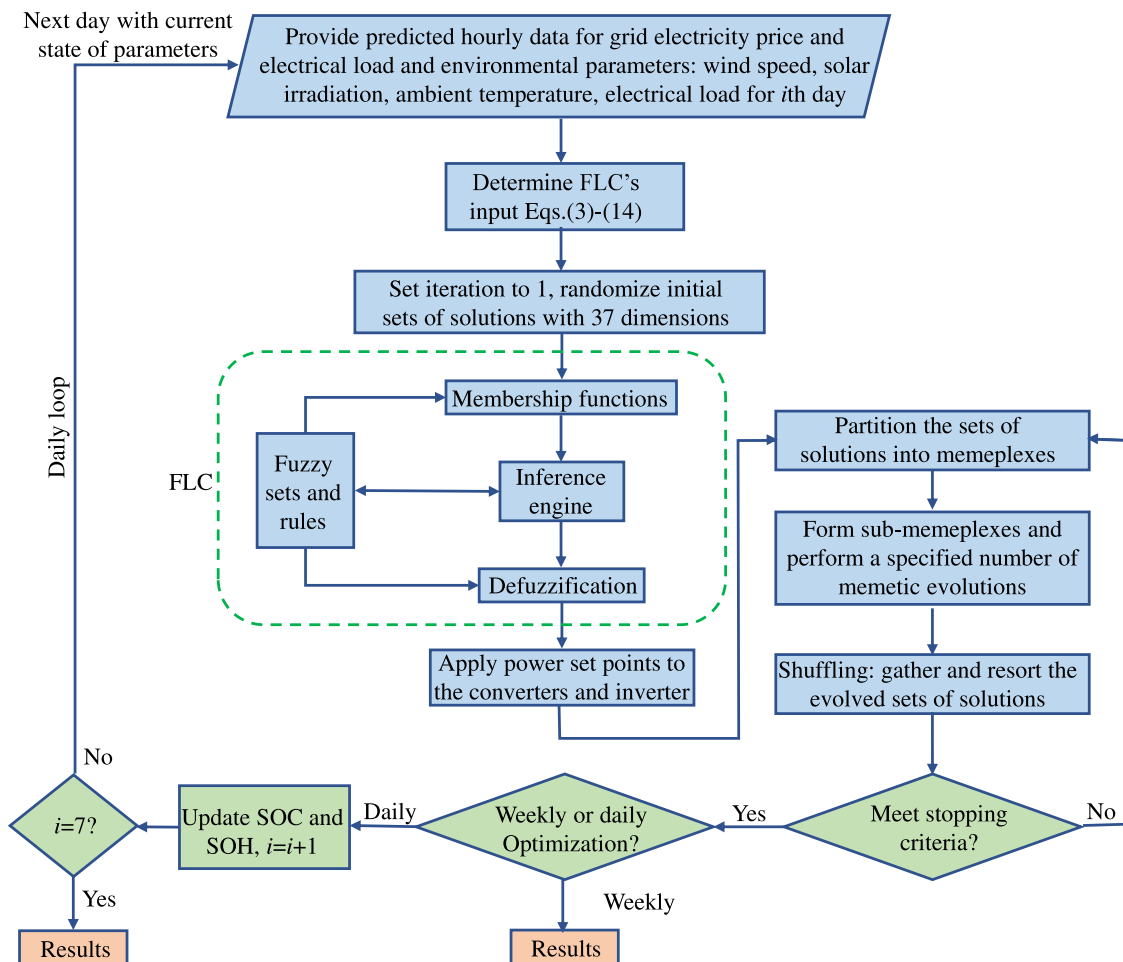

Fig. 2. Flowchart of the FLC optimization process: designing the performance management of energy storage components for grid-connected HRES [55].



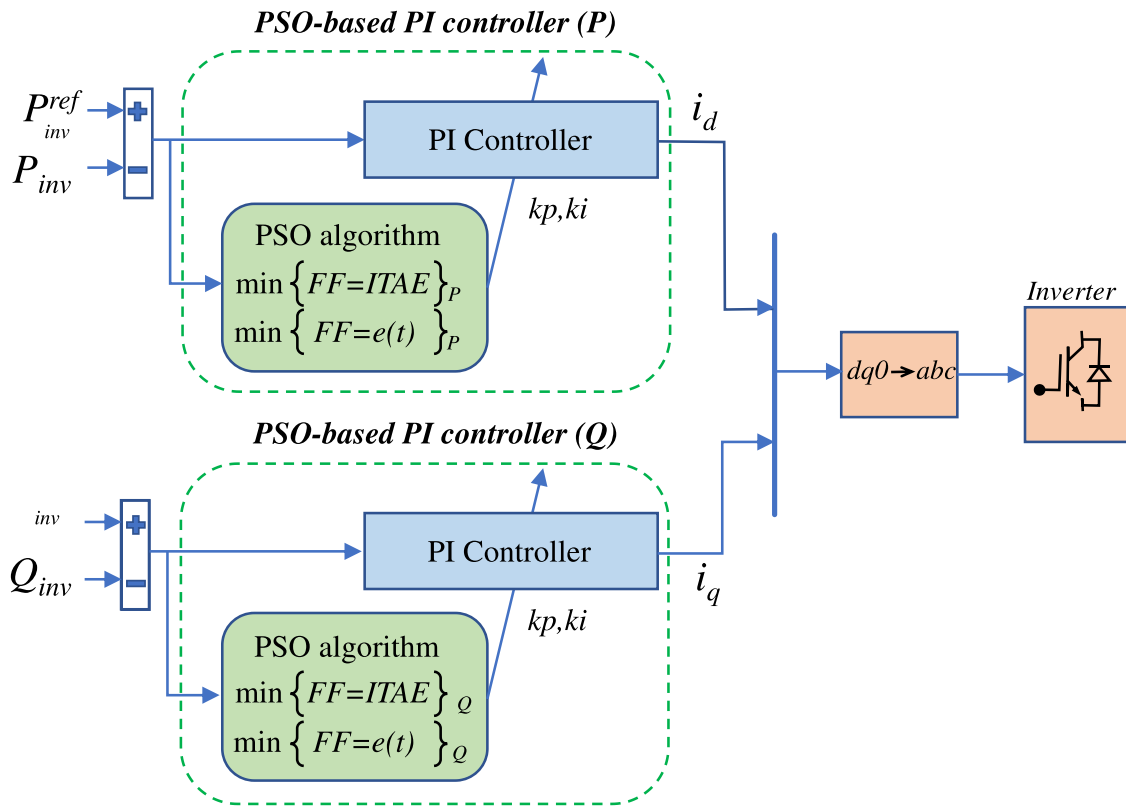

Fig. 3. Inverter power control using PSO-based on-line PI controller [59].

through a newly developed E-PSO algorithm, which was mainly used to optimize different configuration alternatives of a trigeneration cooling, heating and power system based on photovoltaic thermal panels, wind turbines, and thermal energy autonomy to fulfill cooling, heating and power loads. Thereby, it simultaneously achieved the benefits of zero emissions and increased energy efficiency for power generation and consumption. Nuvvula et al. [61] conducted a comprehensive evaluation for a smart city based on renewable energy technologies including floating solar, bifacial rooftop, wind energy conversion systems and solid waste-to-energy generation in Visakhapatnam, India. Mutation-based Adaptive Local Attractor QPSO (ALA-QPSO) was used to obtain the PV and wind energy conversion systems by minimizing the techno-economic targets. Srilatha and Yesuratnam [62] applied the CDPSO algorithm to determine the optimal scheduling of demand response loads on transmission lines in the presence of renewable energy sources and the re-scheduling of conventional generators to mitigate congestions. The optimization is implemented using the CDPSO algorithm to ensure better search capability and to avoid premature local convergence. Fig. 4 illustrates the simulation process of this approach to implement real-time hierarchical congestion management using rescheduling and demand response in the presence of renewable energy sources.

#### 2.1.4. Ant colony optimization (ACO)

ACO is a probabilistic algorithm for searching optimization paths in graphs, which is a simulated evolutionary algorithm with many excellent properties [63]. Eroglu and Seçkiner [64] proposed a heuristic ACO algorithm based on a pheromone update scheme for the continuous optimization of onshore wind farm layouts. The optimization process only functioned as a nonlinear maximization problem. The optimal solution by more accurate layout design and less energy loss was illustrated using farm layouts, and the performance of the proposed algorithm was evaluated on three benchmark problems. It was concluded that the use of the ACO algorithm can help to identify better

wind farm layouts than previous studies without falling into the local maximum of the chosen problem in a reasonable solution time. The proposed ACO algorithm generally outperformed the existing algorithms presented for the continuous problem. Fetanat and Khorasaninejad [65] optimized the sizing in a hybrid PV-wind system based on the continuous domain ACO algorithm for integer programming. Results showed that the proposed algorithm had significant advantages over other AI approaches and conventional optimization methods in terms of achieving optimal solutions and efficiency.

Ju et al. [66] presented a multi-bid game simulation system with an improved ACO algorithm. The improved ACO algorithm was used to simulate the bidding game process of different subjects at different stages to determine the minimum output fluctuation of wind farm and PV and the minimum total energy supply costs of microgrid. The multi-objective optimization can maximize the bidding revenue and minimize the reservation cost, and the overall optimal solution can be obtained rapidly and accurately. Güven et al. [67] proposed a multi-variate heuristic algorithm based on Harmony Search algorithm, Jaya algorithm, and ACO algorithm to optimize the HRES consisting of PV, wind turbine, battery, diesel generator, and inverter, and the corresponding workflow of which is shown in Fig. 5. The main optimization objectives of this study were to fully satisfy the energy requirements of an off-grid university campus, to minimize the total annual costs of operation of the system, and to identify the optimal PV panel power, wind turbine power, and number of batteries.

#### 2.1.5. Other common AI-related approaches

Besides the above-mentioned approaches, other AI approaches (e.g., genetic algorithm (GA), simulated annealing (SA), and cuckoo search algorithm (CSA), etc.) have also been frequently used in renewable energy systems in recent years. These AI techniques have shown satisfactory performance in most of the previous studies, such as high computational efficiency, ability to solve complex optimization problems and fuzzy uncertainties, and facilitate the full utilization of

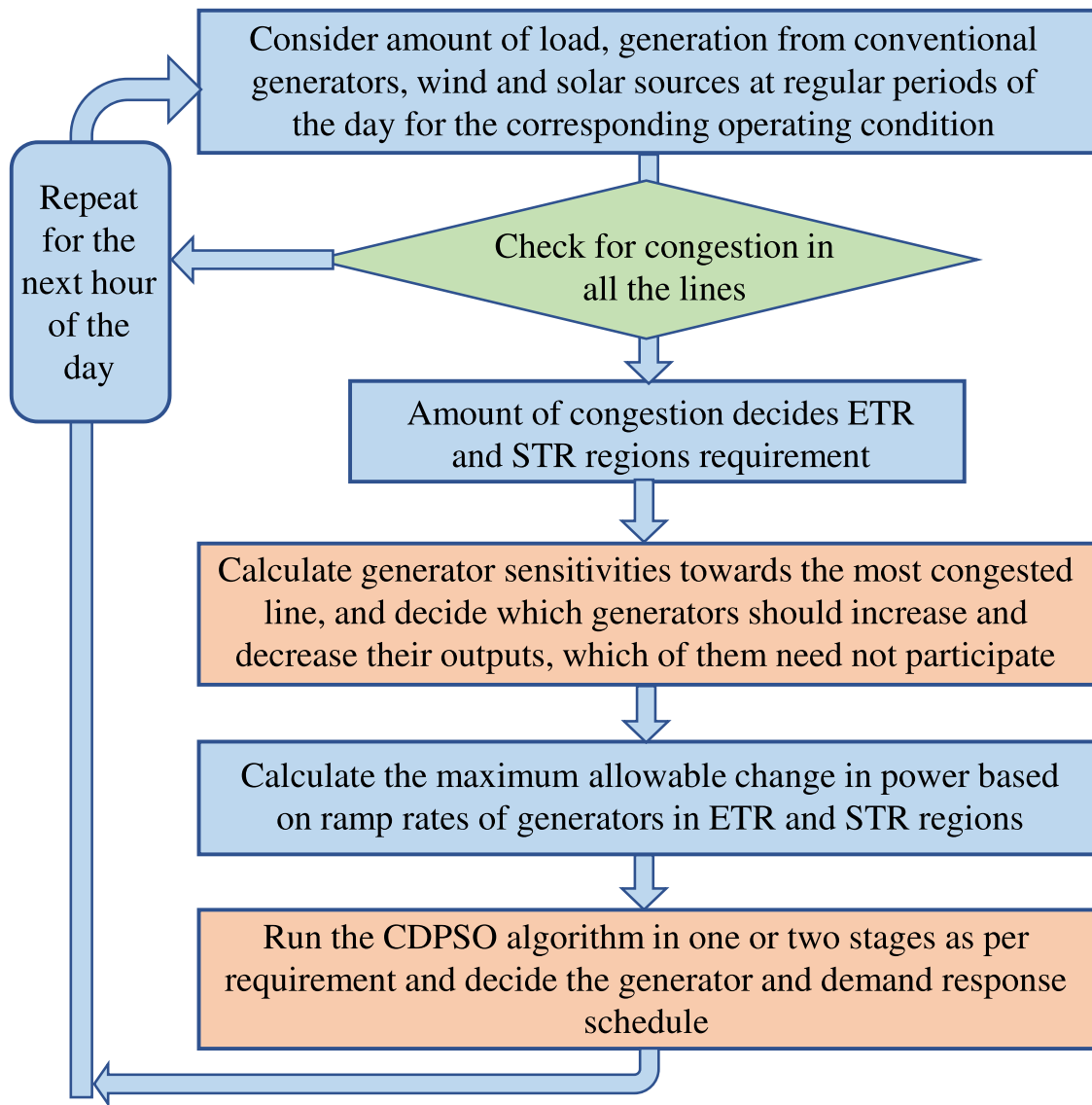

Fig. 4. Flowchart of real-time hierarchical congestion management aided by demand response using CDPSO algorithm [62].

renewable energy potentials [26, 68].

The GA is an evolutionary algorithm that solves optimization problems by mimicking the natural selection process and genetic mechanisms. It can address both single- and multi-objective optimizations [69]. For instance, to address multi-objective optimization problems, the Non-Dominated Sorting Genetic Algorithm II (NSGA-II) could be used [70]. Although the GA algorithm may be relatively low efficiency compared to some conventional optimization algorithms, it is less likely to be trapped in a locality optimum. Therefore, it becomes a prevalent tool to search for optimization solutions in many fields, including renewable energy, energy storage and other scenarios such as solar, wind, geothermal and fuel cells [43, 71, 72]. Besides, SA algorithm, which has been recently introduced as an effective optimization technique, has been widely applied to the optimization of hybrid systems of renewable energy and energy storage technologies (e.g., hydrogen storage, fuel cells) [73], optimization of wind- and solar-powered desalination systems [74], optimization of integrated energy systems for smart buildings [75], etc. These applications demonstrated its superiority in optimal planning, charging and scheduling of ESS, and energy management capabilities. The CSA algorithm is a metaheuristic optimization algorithm inspired by the reproductive behavior of cuckoos. It can be applied to optimize the grid-connected capacity of

renewable energy generation and to achieve multi-objective optimization of integrated systems with constraints on economic, technique and environment [76]. In addition, a multi-objective CSA algorithm can build national energy transition strategies by minimizing the total annual cost and maximizing the shares of renewable energy [77].

Although AI approaches can achieve optimization and/or performance prediction of renewable energy systems and their integrated applications in most cases, each approach has its own shortcomings and may encounter different barriers during practical applications [78]. In the case of complex integrated systems, achieving well optimization or prediction by a single AI approach could be a challenging task due to the complex objective function. It reveals the necessity and feasibility of combining different AI approaches [79–81]. Therefore, integrating different AI techniques for energy management of large-scale renewable energy systems seems necessary to maximize the utilization of sustainable energy to achieve carbon neutrality.

## 2.2. Advantages and functional roles of intelligent techniques

AI techniques have demonstrated promising performances in most previous studies, such as improved computational effectiveness, resolved complicated optimization processes with ambiguities or

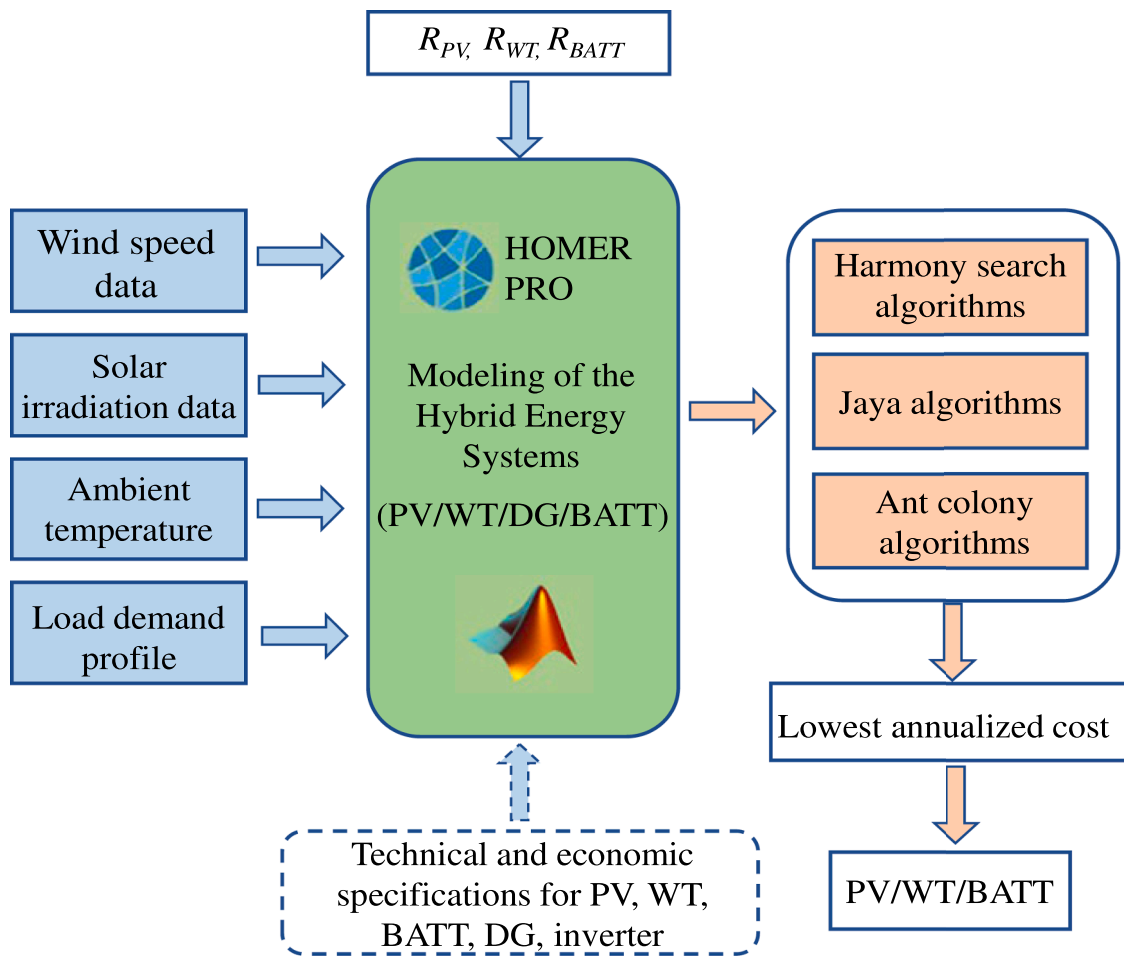

Fig. 5. Flowchart of green energy system design based on Jaya-Harmony Search and ACO algorithm [67].

uncertainties, and contributed to fully exploiting potentials of renewable energy sources [82, 83]. In recent years, AI techniques have played an essential role in information retrieval, decision-making, automatization, intelligent identification and management [84, 85]. Under the help of AI techniques, intelligent large-scale RES creates new avenues for researches and applications.

Existing studies have demonstrated the considerable influence of AI techniques on applications of large-scale RES, which replaces traditional rule-based approaches with data-driven techniques to aid their scientific prediction and decision-making processes [20, 32]. AI-based prediction models show the advantage of discovering pattern from data with no requiring of expertise knowledge on the predictive problems [86]. Thus, AI-based renewable energy predictive models show the ability to account environmental/social-economic effects.

Besides, AI-based predictive models could be utilized as a basis for energy management or device control. Mahmoud et al. [87] reviewed the commonly used intelligent microgrid control strategies, such as model predictive controller (MPC) and robust controller. Meanwhile, Rostami et al. [88] summarized intelligent optimization methods for adjusting the control parameters. The reviewed optimization methods include fuzzy logic, PSO, and bacterial search algorithm. The main advantage of fuzzy logic is that it could solve non-linear optimization problem, while PSO shows the strength of optimizing nonlinear, non-differentiable and multi-modal function.

The advantages of AI-based MPC mainly include:

- Fast computing.
- Able to control constraints and interactions among variables.
- Predictable of system dynamic behaviors.

- Applicable to large multivariable processes.
- User-friendly for non-professional researchers and cross-disciplinary research.

On the other hand, the advantages of robust controllers include:

- Useful for multi-input and multi-output models.
- Avoiding disturbance from perturbations.
- Applicable for cross-coupling.

Moreover, AI techniques could be utilized to detect islanding conditions of renewable energy integrated power systems, which refer to abnormal conditions that distributed generation (DG) still provides power even though it is disconnected from the distribution grid [88]. Panigrahi et al. [89] provided an example of islanding in a multi-renewable-energy-integrated power system, as shown in Fig. 6. Then, they compared AI-based islanding detection methods with conventional methods, and summarized the advantages of AI techniques as below:

- Better accuracy.
- Smaller non-detection zone (NDZ), i.e., the period of detection failure after islanding takes place.
- Easy to be applied for multiple DG unites.
- Unnecessary to select thresholds.

Memon et al. [90] reviewed nine commonly used bio-inspired intelligent algorithms (BIAs) for eliminating harmonic in inverters when regulating DC power generated from renewable energy into AC



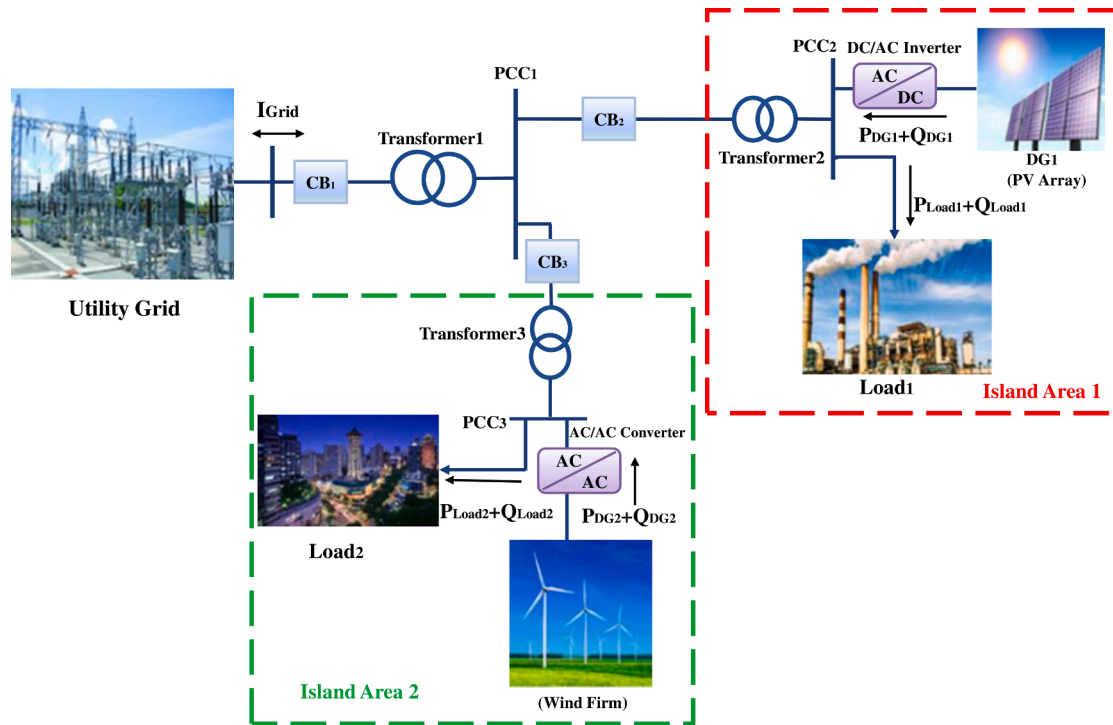

Fig. 6. Islanding in a multi-renewable-energy-integrated power system [89].

power. The reviewed techniques are shown in Fig. 7. Then, they evaluated the performance of five best bio-inspired intelligent algorithms and found that all of them are easy to implement. Among them, PSO shows the best accuracy, fastest convergence speed, and lowest computational cost. Besides, it is suitable for generating dataset for training ANN and search for the firing angles of type-b output waveforms.

Nevertheless, it is important to note that AI techniques are not consistently the optimal alternative under all situations. Conventional methodologies may be a preferable choice when the available data samples are sparse or the controlled system needs to be remained uncomplicated [43]. In practices, the biggest challenge for traditional AI-based models is to characterize complicated wind power fluctuations, resulting in suboptimal wind power prediction accuracy [16]. Therefore, some advanced deep learning-based models should be considered to promote developing more feature-powerful wind power prediction software in the future studies.

### 3. Advanced applications of AI techniques in large-scale renewable energy integrations

The aforementioned extensive analysis shows that AI techniques can make large-scale renewable energy generation more intelligent and reliable, optimize demand response, manage power, and improve computational efficiency [42]. Acharya [91] classified the common problems in large integration of RES into two categories, i.e., supply-demand problems and distribution network side problems. Supply-demand problems mainly include energy saving and/or CO<sub>2</sub> generation reduction during renewable energy generation and consumption. On the other hand, distribution network side problems are usually related to distribution network planning, renewable penetration percentage in the grid, and component allocations, etc.

Besides, Blaabjerg et al. [92] summarized the requirements for design/operate RES from perspectives of generator, power conversion and grid. These requirements for wind turbine power and PV power systems are illustrated in Figs. 8 and 9, respectively. They also reviewed the grid integration requirements, which required the RES to enable

passive injection of extracted power into the grid and proactively manage the power exchange between generating units and the grid.

Furthermore, Serban and Lytras [93] summarized AI technique applications in large-scale integration of RES, with respect to generator side, grid side, and consumer side, respectively, as shown in Fig. 10. Simulating renewable energy sector through AI techniques could achieve a better monitoring, operation, maintenance and storage for RES. For instance, AI-based renewable energy generation prediction could provide a basis for demand side management to narrow the gap between energy generation and consumption, and thus, improve the grid stability.

Therefore, in the next section, overviews on AI techniques in renewable energy studies are organized from perspectives of generator side, distribution network side and demand side.

#### 3.1. Generator side

##### 3.1.1. Configuration optimization

For typical solar or wind energy systems, the drawbacks and limitations that arise from intermittent power supply need to be taken into account. This indicates more robust, resilient, manageable and reliable solutions with consideration of economics and system energy absorption for a well-designed HRES. Oversized systems involve high investment costs and additional difficulties associated with a large system footprint. Otherwise, an undersized system may involve little investment cost, but operational limitations may cause inadequate energy supply. To efficiently utilize renewable energy sources, it turns out to be essential to perform an optimal design of HRES, especially considering the intelligent techniques that are available for providing load requirements under reliability and cost constraints to determine its optimal design [94]. Mercado et al. [95] applied genetic algorithm to optimally size a HRES that contained wind turbines, PV panels and battery storage systems. Detailed configuration of the HRES is shown in Fig. 11. The optimal number of wind generators, PV panels and battery banks was calculated to balance the cost and reliability of the proposed system. In other words, the objective functions included the loss of power supply, initial capital cost, and life cycle cost.

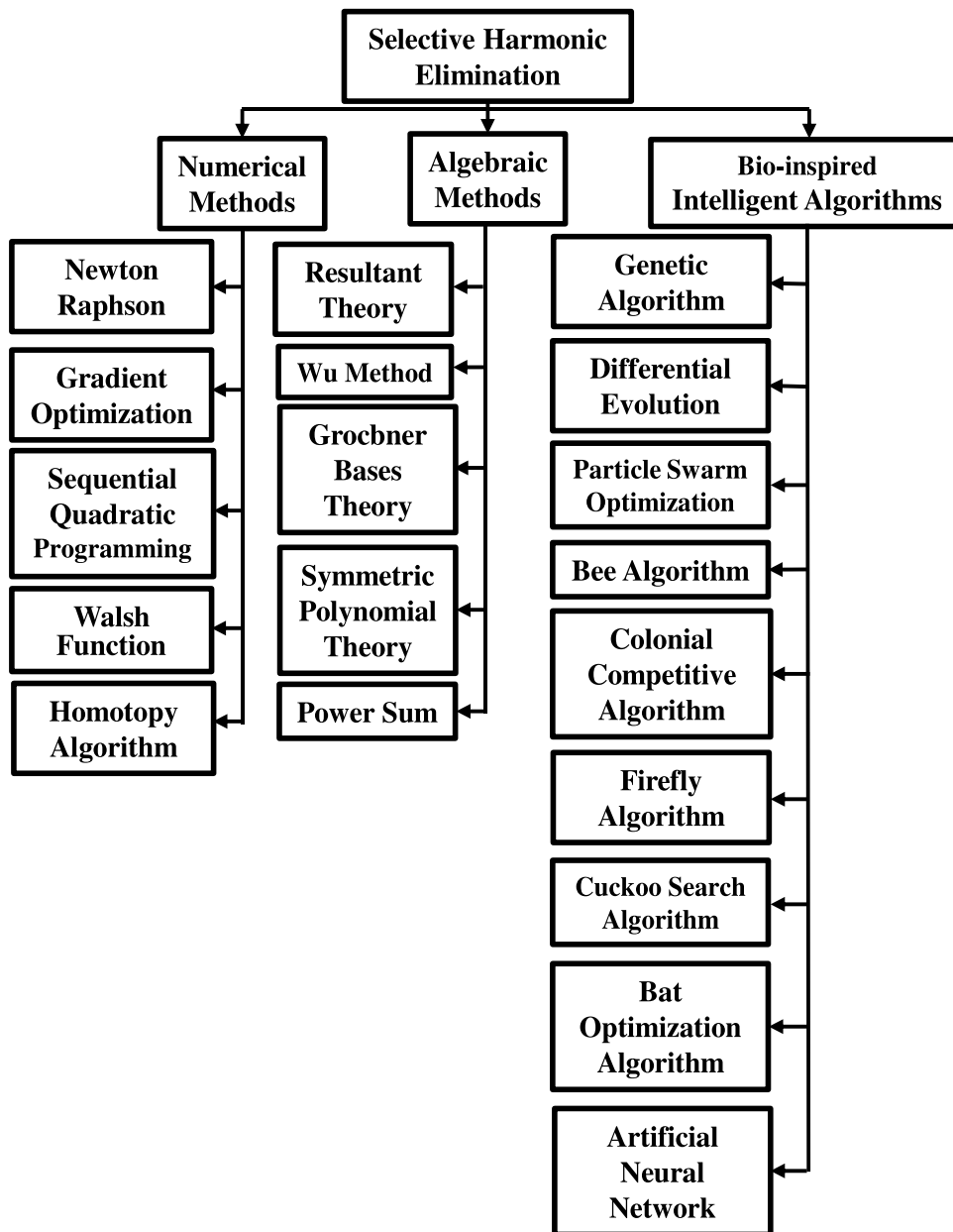

Fig. 7. Selective harmonic elimination techniques [90].

Al-falahi et al. [96] conducted a comprehensive review and critical comparison on optimization approaches based on independent solar and wind hybrid energy systems. This study revealed an increasing interest towards developing optimization algorithms for stand-alone HRES. To date, the reported optimization methods can be roughly classified into classical algorithms, modern techniques, and software tools. The modern techniques, based on a single AI algorithm, are getting preferred over classical algorithms due to their capability to address some complicated problems. Recently, a noticeable trend has been towards using hybrid algorithms instead of single algorithms, predominantly due to their capability for providing more promising optimized results. In addition, this study also provided a rigorous comparison of hybrid algorithms, single algorithms, and software tools to determine the scale of stand-alone solar and wind-based HRES. An assessment of all potential combinations of stand-alone solar and wind systems was also presented, including their evaluation parameters in terms of economic and reliability, as well as environmental and social considerations.

### 3.1.2. Renewable energy prediction

With the increasing advancement of PV power generation technology, grid-connected scale of PV power generation is also expanding. However, the indirectness, randomness and fluctuations influenced by climatic factors of PV power generation have posed many problems for its grid connection [97]. Power forecasting has been an essential task, however, short-term forecasting (e.g., hourly to daily) at different prediction time scales plays an important determining role in real-time grid dispatch, which directly affects the security of the grid and the stability of system operation. Hu et al. [98] extracted the dynamical features of sky clouds using indirect prediction methods, and processed the input data in accordance with different meteorological characteristics, and then forecasted the PV output via radial basis functional neural networks.

As a fact, the conventional machine learning theory requires a large amount of trained data and performs unsatisfactorily when the amount of data is small. Therefore, to streamline the forecasting process and further enhance the short-term forecasting accuracy of PV power

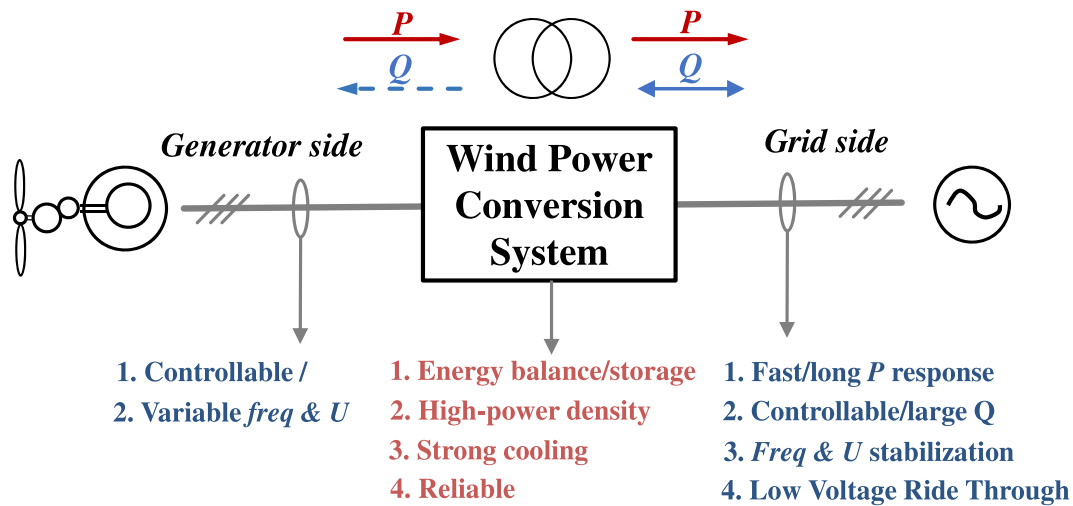

Fig. 8. Design/operation requirements of wind turbine power systems [92].

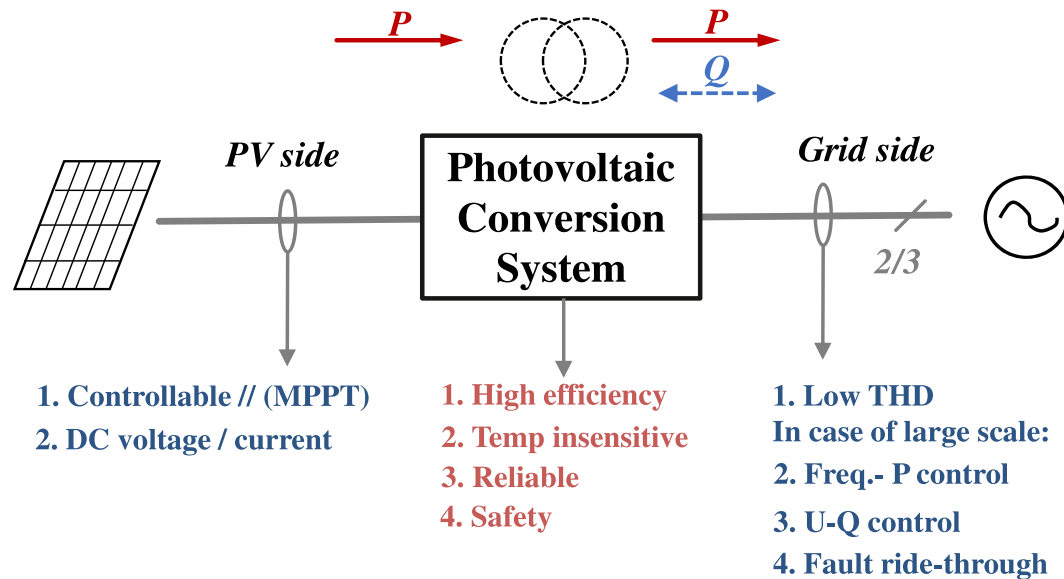

Fig. 9. Design/operation requirements of PV power conversion systems [92].

outputs, an advanced model with less automatic parameters and higher generalization capabilities is required as a prediction model for small sample. Li et al. [99] proposed a hybrid improved multi-verse optimizer (HIMVO) algorithm, whose running process is presented in Fig. 12, to improve the photovoltaic predictive performance of support vector machine (SVM). The hybrid HIMVO-SVM model outperforms PSO-SVM, multi-verse optimizer SVM, reverse propagation, and radical base functional neural network. The predictive output could be further utilized to maintain the power system stability. Results indicated that the proposed model had a high prediction accuracy and stability. The values of the average square error of HIMVO-SVM model were decreased by at least 0.0026, 0.0030 and 0.0012, and the corresponding average absolute percentage errors were decreased by at least 3.6768%, 1.9772% and 2.7165%, respectively. This proposed method was beneficial to the output power prediction, as well as economic dispatch of power grid and maintenance of power system stability.

Regarding the forecasting of renewable energy generation and power loads under univariate and multivariate scenarios, Xia et al. [100] proposed an adapted superposed gated recurrent unit-recurrent neural network (GRU-RNN) to predict wind power generation. The structure of GRU-RNN is shown in Fig. 13. In this study, AdaGrad and mobilizable

quantities were integrated to modify the training algorithm with adaptive learning rate to improve the training effectiveness. The constructed GRU-RNN was then used to establish an accurate mapping between monitoring parameters and renewable energy generation or electricity loads. The developed prediction method can satisfy both multivariate and univariate scenarios. The improved GRU-RNN can decrease the model complexity by using less parameters, thereby saving computational costs and requiring less training data. Experimental results of actual wind power generation and electric load forecasting demonstrated the feasibility and superiority of the proposed method by comparing it with other advanced data-driven forecasting methods. However, several limitations of this method still remained, such as some hyperparameters being empirically determined, the training time being much longer than that of the shallow model, and the requirement of a considerable training sample. In the future, the forecasting performance can be potentially improved by further upgrading the trained strategies and investigating additional monitoring parameters. In addition, it is possible to develop advanced modeling and accurate prediction of power generation from multiple renewables, as well as to detect power load anomalies caused by extreme conditions.

Shami and Cuffe [101] discovered the value of predicted market

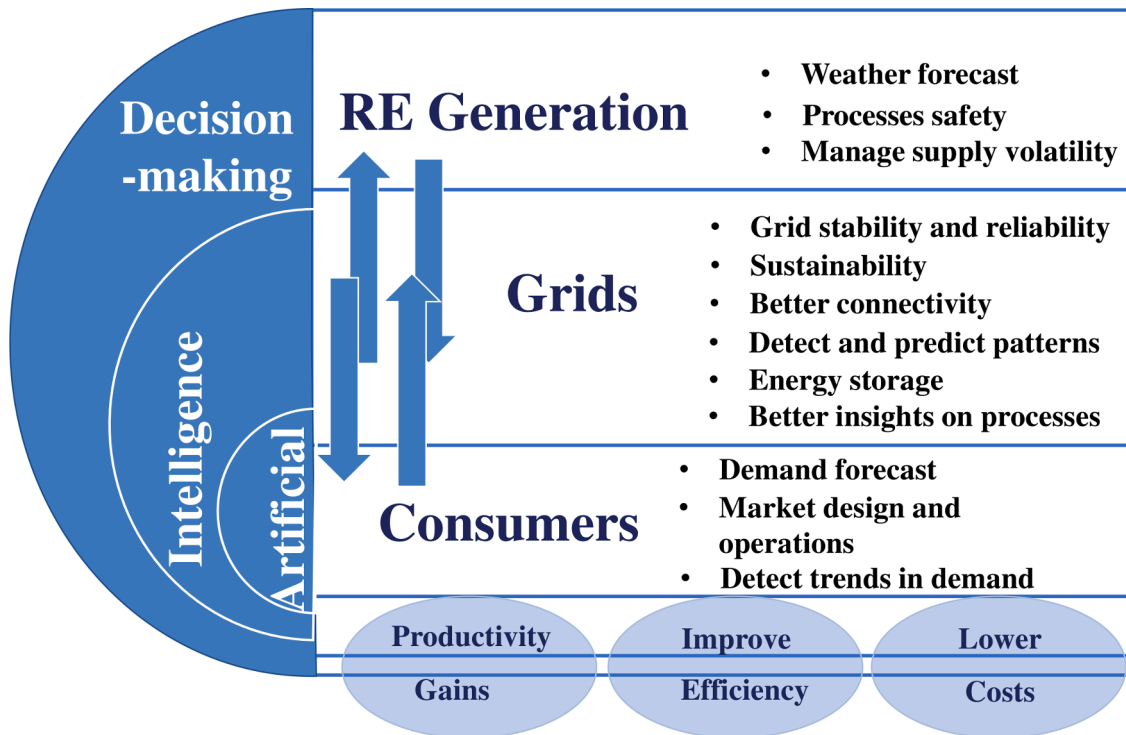

Fig. 10. Application of AI techniques in RES [93].

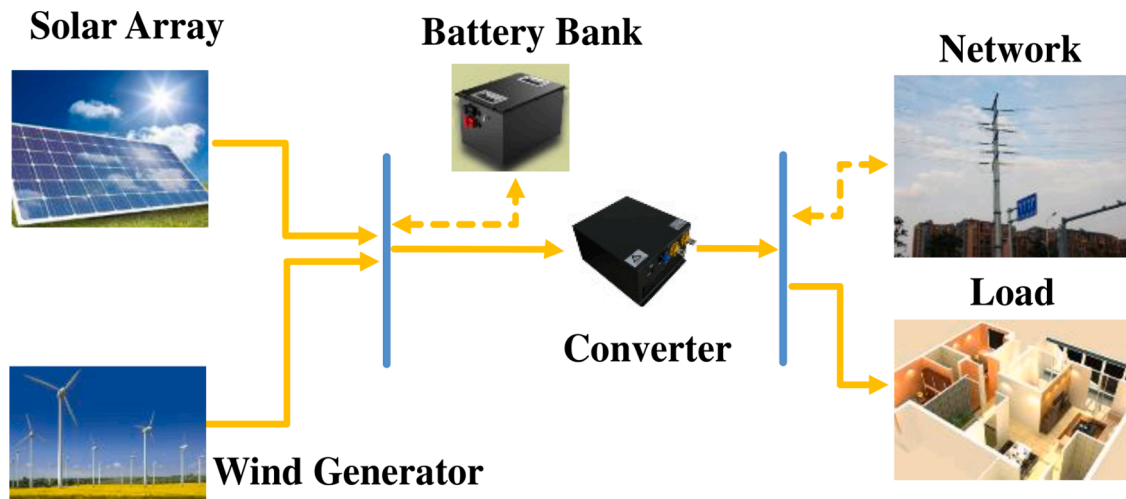

Fig. 11. Configuration of the HRES [95].

price on renewable energy prediction. Their proposed binary prediction market was applied to probabilistic onshore wind power forecasting. Test cases were established for three onshore wind farms in Australia. Results showed that the proposed method outperformed individual models in terms of reducing the electricity market imbalance costs. Furthermore, there are also a plenty of studies on renewable energy prediction by AI techniques, and the detailed review on these studies could be found in [102–105].

### 3.2. Distribution network side

#### 3.2.1. Harmonic elimination (HE) during power conversion

Inverters perform an essential function with regard to dynamic stability control and voltage adjustment of power systems, which are widely used in the renewable energy and power industries, and they

have numerous advantages in large-scale energy systems [106, 107]. However, the output voltages of conventional inverters contain a substantial amount of unwanted harmonics that may negatively affect the system’s mechanical and electrical components. The existence of harmonics in the inverters increases the switching losses of energy switches, thereby lowering RES efficiency and deteriorating the overall system performance [108, 109]. Mohamed et al. [110] proposed an adaptable controller for DC-AC inverters in grid-connected PV power systems for supplying pulsed AC loads, as shown in Fig. 14. The predictive neural network controller (PNNC) can forecast control parameters by tracking the mean square errors of grid electric current and DC base-voltage, and eliminating these errors in a remarkably short finite time. Results revealed that the proposed adaptive controller provided a more rapid dynamic response with shorter stabilization time and smaller maximum overshoot of current and voltage variables. In addition, these data also

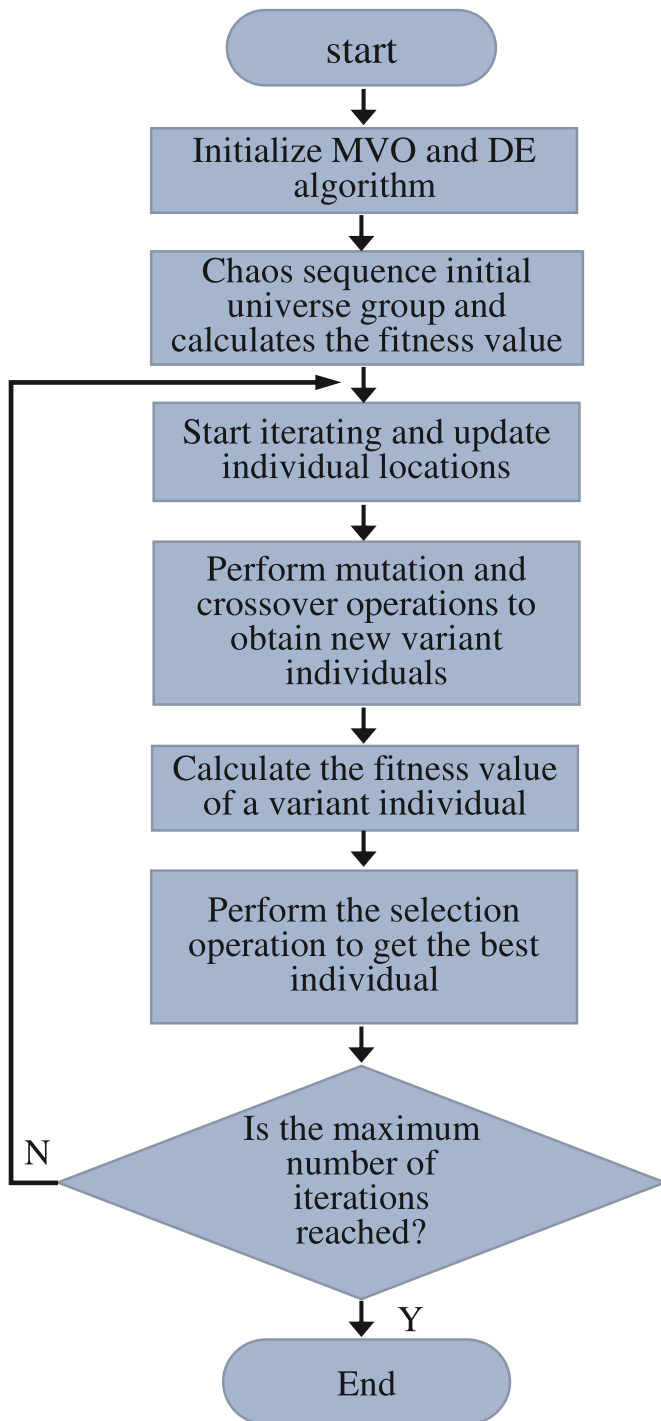

Fig. 12. The running process of HIMVO algorithm [99].

indicated a significant reduction in the harmonics injected into the power grid, displaying a total harmonic distortion of only 1.97% compared to that of 5.06% for the conventional controller. This enables the used PV systems to fulfill the requirements of international standard IEEE 519 for harmonic control of power systems.

Rao et al. [111] proposed an adaptive neuro-fuzzy interference system (ANFIS) to eliminate the voltage harmonics being present in multi-level inverters. Through the augmented knowledge rule bases, the proposed ANFIS generated switching angles for suitable voltage variations, which can be realized by lowering the total harmonic distortion (THD) of the multilevel inverter output voltage. Its performance was compared with the output voltage THD of the multi-level inverter

without controller and with neuro-fuzzy controller (NFC). Results revealed that ANFIS controller performed better than NFC, and the proposed method had less THD under various load conditions. Rahmani and Deihimi [112] presented an intelligent system with nonlinear auto-regressive model based on exogenous inputs and wavelet analysis. The proposed system can be regarded as one monitor that eliminates sensitive loads, thereby lowering the optimal number of power quality monitors and monitoring costs for distribution networks.

### 3.2.2. Fault and islanding detection

Islanding occurs when renewable DG supplies power to the load after the grid is disconnected, which is dangerous for the site personnel and related machinery because maintenance workers are unaware that they are connected and powered by DG [113, 114]. The critical explanations for such accidental islanding are incidents such as power grid faults, deliberate opening of breakers for maintenance and other events that cause the breakers to be opened towards the grid [115, 116]. Effective diagnosis of islanding detection with imbalance conditions, non-detection zones, and fault misoperation can be performed using ANN. Mohapatra et al. [117] used artificial neural network techniques with decision-making tree features and multi-stage perceptual neural networks (MLPNNs). MLPNNs would be trained by reverse propagation method to diagnose faults. Studies showed that the accuracy of obtained results using artificial neural network techniques was 99.1% in fault diagnosis. The existing SVM, Bagging, Random Forest (RF) and Decision Tree Algorithms (DTA) achieved accuracies ranging from 97.8%, 98.9%, 98.9% and 83.33%. Therefore, the proposed method in this study had higher accuracy, resulting in better diagnostic quality than the existing methods.

Darab et al. [118] pointed out that the commonly utilized AI techniques, such as ANN, SVM, fuzzy logic, and GA, were difficult to be implemented to detect faults in distribution power systems, due to the fact that they required high volume of training dataset and its time consuming for data collection and model training. They proposed a novel AI algorithm, namely wavelet transform, to transiently detect islanding conditions based on frequency change in a short period, as shown in Fig. 15. The proposed method used frequency domain and time domain analysis to examine the voltage variations in the grid. The advantages of the wavelet transform method over conventional islanding detection methods were the capability to determine frequency variations transiently in a short time. Overall, the proposed detection method can overcome conventional methods with regard to detecting balanced and unbalanced voltage sawtooth/surge as well as frequency-dependent variations in DG networks.

### 3.2.3. Control of renewable energy storage

Energy storage, as a significant and regulated component of power grids, can supply a short-term energy supply that enables seamless off-grid switching [119–121]. Energy storage technologies have been considered as an essential factor to facilitate renewable energy absorption, enhance grid control, and ensure the security and cost effectiveness of power grid services [43, 122]. Applications of AI techniques cover many aspects including parameter estimation, optimization design, and operational control of energy storage and RES integration [24]. Zhou et al. [123] proposed a gray prediction model based on error correction to predict the renewable energy storages. This model ensured the long-term predictive accuracy on remaining useful lifetime for lithium-ion battery and fuel cell. Considering the predictive results, maintenance of renewable energy storage could be scheduled earlier. Zangeneh et al. [124] proposed an intelligent multi-input/output FLC to manage the HRES's operation (as shown in Fig. 16) that included a PV panel, a lithium-ion battery box and access to the power grid. The proposed controller ensures that the battery was charged by solar energy or the power grid and discharged in special weather conditions.

Kermani et al. [125] proposed a centralized energy management system with supervisory control and data acquisition to minimize the

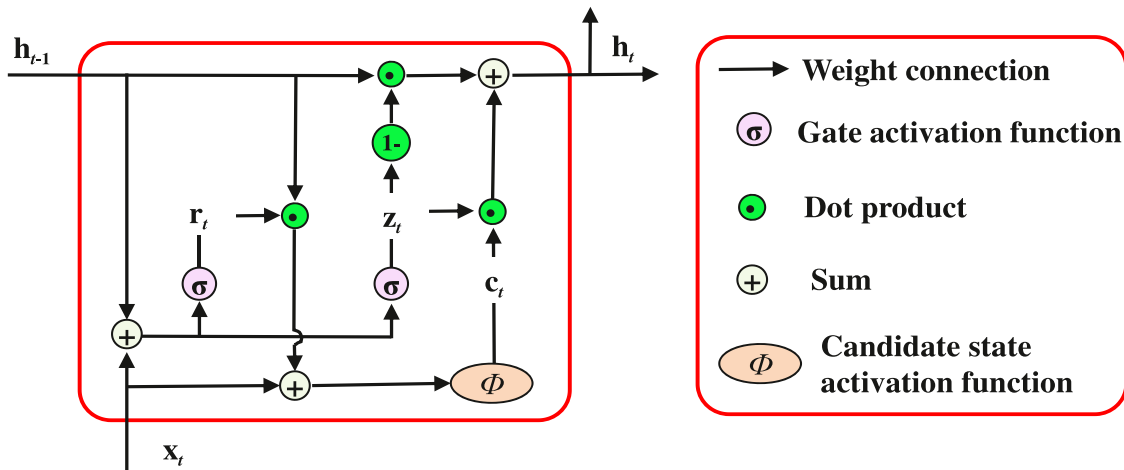

Fig.13. Structure of GRU-RNN [100].

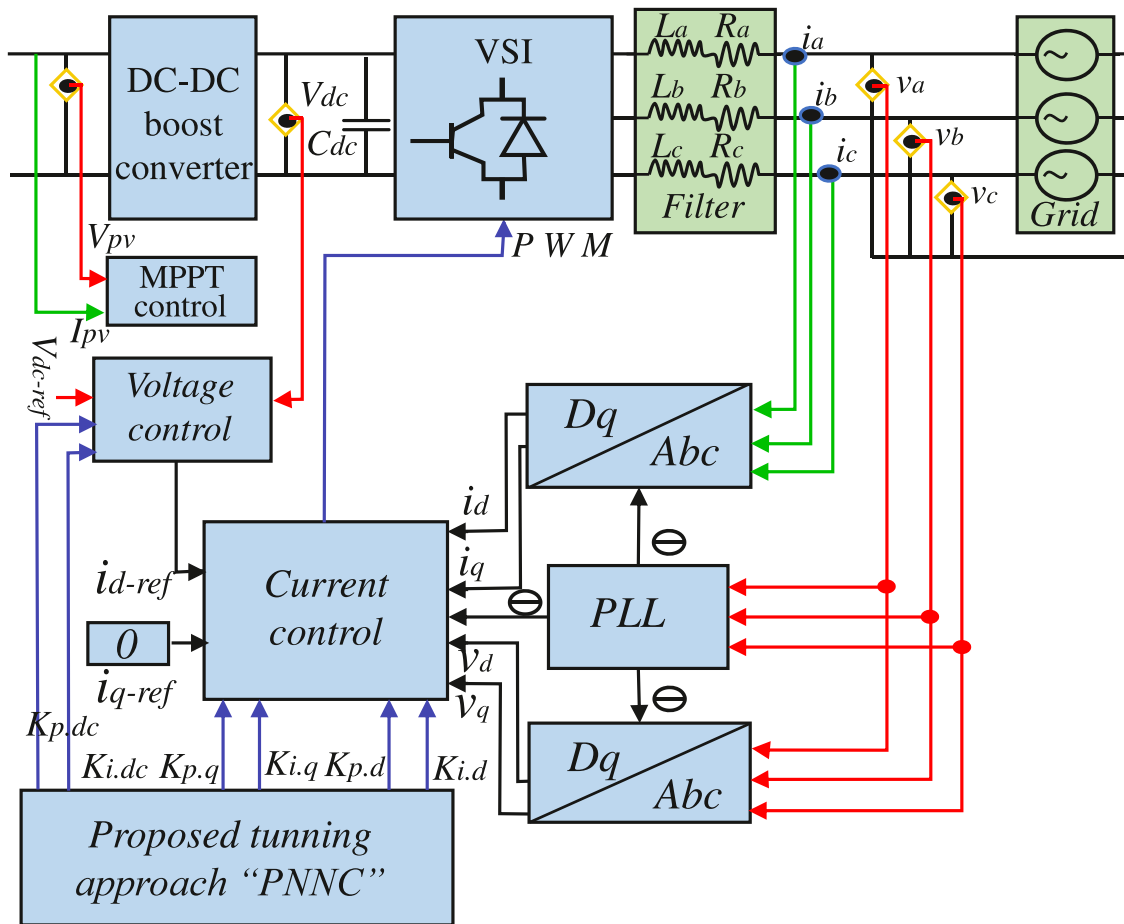

Fig. 14. Control scheme of DC-AC voltage source inverter for considered grid-connected PV system [110].

power exchange between a microgrid and main grid by controlling the energy storage in battery energy storage system. The proposed system declined monthly electricity bill by ~87% and led to a near zero energy building system. Fikiin et al. [126] discussed the possibility of utilizing refrigerated warehouse as an intelligent hub within the power grid to enhance the efficiency of the cryogenic energy storage and thus to ensure the power grid sustainability when integrating renewable energy into it. The arrangement of the proposed system is illustrated in Fig. 17.

### 3.3. Demand side

Similar to renewable energy prediction, AI techniques have been extensively applied for load demand prediction [127–130]. The predictive results of energy consumer and supplier could be utilized as a basis for demand-side management to increase the percentage of renewable energy utilization, decrease electricity bill, or shift the peak load. Shah and Ansari [131] mentioned that an intelligent energy management system in a direct current microgrid integrated with RES



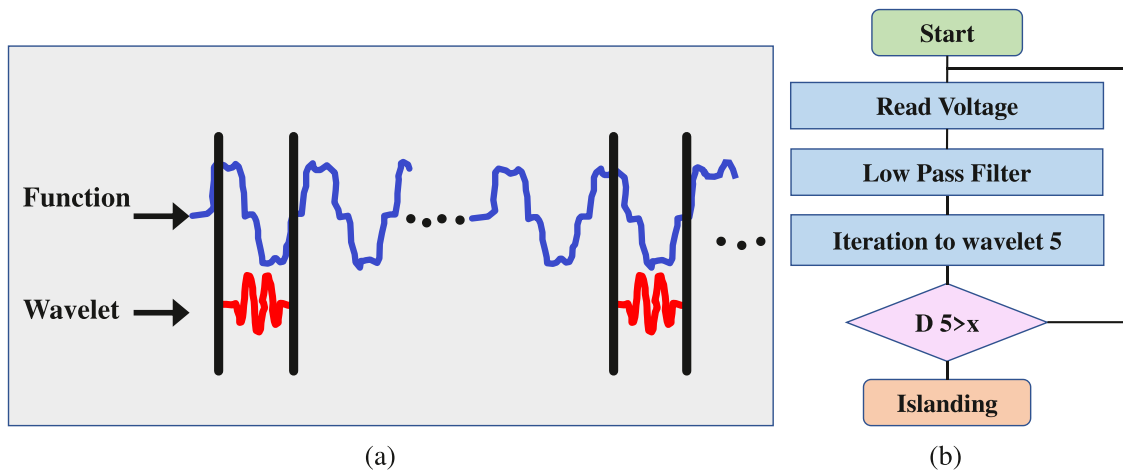

Fig. 15. (a) Wavelet sampling representation; (b) Algorithm logic representation [118].

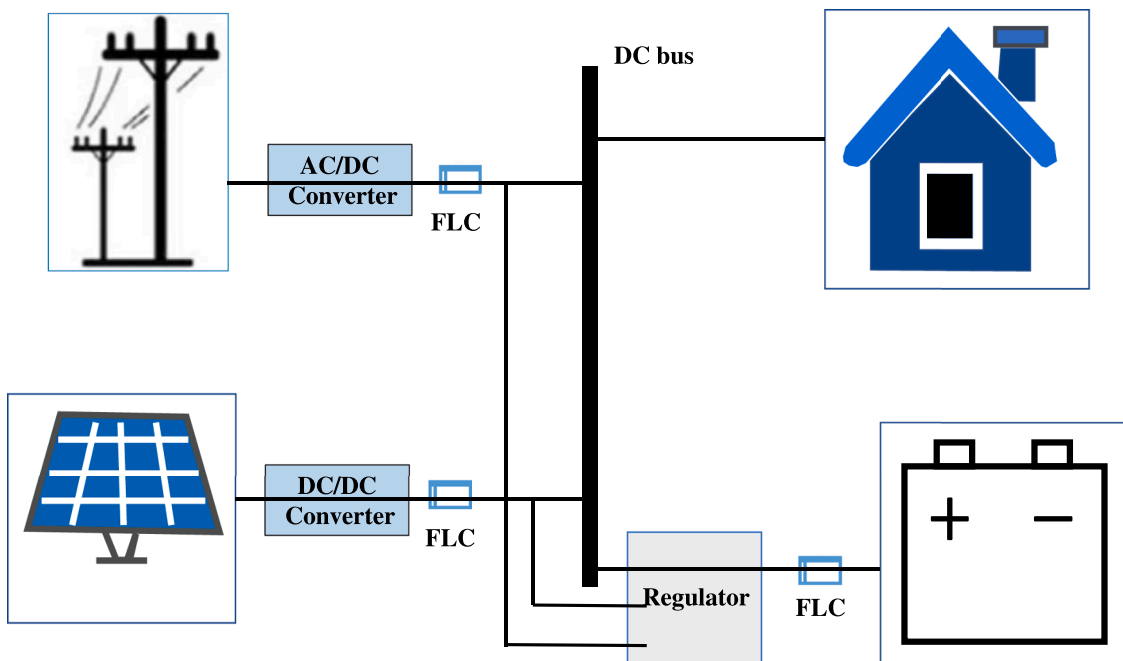

Fig. 16. The studied hybrid power system [124].

could minimize energy usage of AC grid by consuming energy from efficient renewable source and scheduling critical energy load events. Its functions were achieved by intelligent electronic devices that showed the ability of power transmission, information exchange and load control.

AL Hadi et al. [132] tested an intelligent demand response algorithm on a microgrid system that contained air conditioners, lights, PV panels, wind turbine system, and lead-acid battery banks, as shown in Fig. 18. This algorithm controlled the load patterns considering the predicted state of charge of batteries, to provide users an uninterrupted power supply while maximizing the renewable energy usage. Their experimental result showed the capability of maximizing RES's utilizations while decreasing peak requirements, cost of end-users, and CO<sub>2</sub> emissions.

Javaid et al. [133] utilized evolutionary algorithms, e.g., binary PSO, genetic algorithms, and cuckoo search, to optimize appliances in residential homes integrated with PV panels. Simulation results showed that these methods, especially cuckoo search, could reduce the electricity bill through scheduling appliances. Ma and Li [134] proposed an energy

scheduling system for a home RES to reduce energy consumption and increase renewable energy usage rate based on some advanced prediction methods. Ameer et al. [135] presented a multi-agent framework to optimize the power demand in a HRES. The proposed framework includes a supervisory agent, wind turbine agents, PV agents and load agents. These agents can achieve decentralized control of the studied system. Results indicated that this system could fulfill the load requirement and simultaneously maintain battery levels between the minimum discharge rate of 30% and the maximum charge rate of 80%.

#### 4. Challenges and limitations of AI techniques for large-scale renewable energy integrations

According to the global decarbonization target and the current development tendency, a large number of renewable energy generation systems will be connected to the grid in the future [136, 137]. For example, small distributed RES may generate electricity and sell it back to the grid. Electric vehicles and associated techniques (such as fast charging piles) will show boosting demand in the market. Smart home

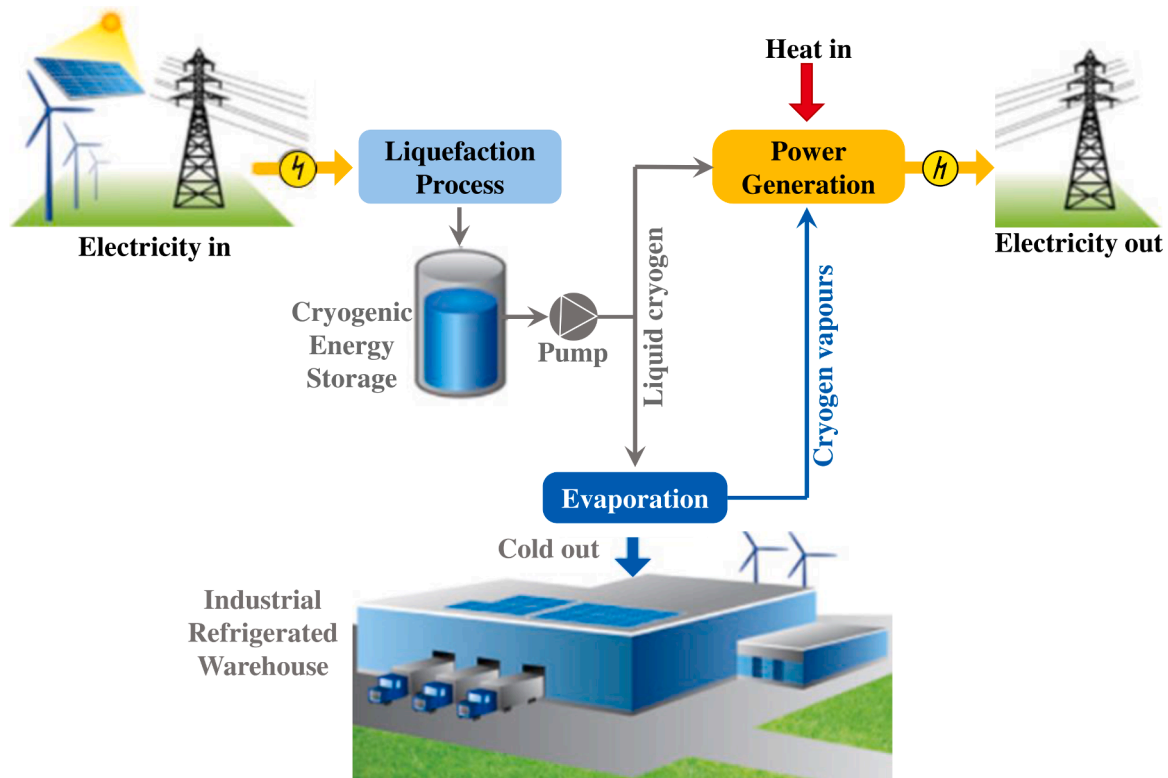

Fig. 17. Integration of refrigerated warehouse into RES and cryogenic energy storage [126].

devices may be connected to the grid even without the awareness of the grid operator. All of these would have a significant impact on the power stability of local utility grid [138–140]. Optimizing the grid operation with the aid of AI techniques, further improving the transmission and distribution capacity of existing lines, and extending the service lifetime of equipment would be critical factors in supporting the renewable energy transformations [141–143]. However, the application of AI techniques in large-scale renewable energy integration still encounters many barriers and limitations [4]. They are mainly reflected in the following aspects.

- 1) Slow update of intelligent equipment integration: the large-scale integrated application of renewable energy, especially with the network grid or fulfilling different requirements of users, requires advanced intelligent control equipment. However, the traditional grid control equipment is generally relatively outdated, leading to the mismatch with latest advanced systems and difficult to realize diversified control at the same time [144, 145]. The simultaneous application of existing intelligent control equipment and those new ones will bring some challenges to the development of AI techniques. The existing control equipment is difficult to support the new renewable energy generation network. Therefore, these old control devices need to be updated to support the new layout of the energy sectors [146, 147]. In addition, exploring new intelligent control methods or advanced algorithms to achieve synergistic operation between existing equipment and new intelligent equipment, is also beneficial to the large-scale development of RES and reduce the replacement of old control equipment.
- 2) Limitations of advanced algorithms for AI techniques: the performance uncertainty about how to predict RES via deep learning theory is one of the most significant factors for the successful application of AI techniques [68, 148]. This is primarily due to the large number of uncertainties in renewable energy generation systems. Among them, there are stochastic factors in the source-grid-load-storage, and generation-transmission- distribution-transmission for RES.

These uncertainties are one of the critical challenges for the development of AI prediction techniques.

- 3) AI prediction techniques encounter multiple challenges: existing techniques show that predicting the generation time and power output of solar and wind energy facilities remains difficult. AI techniques could enable prediction of power generation from solar and wind facilities by learning from historical weather data, sensor data (e.g., real-time wind speed and sunlight intensity measurements), and image and video data (e.g., satellite cloud maps) [141, 149]. Furthermore, AI-power surrogate model can be user-friendly, computational efficiency with high prediction accuracy [150], performance prediction under multi-level scenario uncertainties [151], and robust optimization with multi-level uncertainties [152]. However, this forecasting process is also quite complicated and may lead to power outages or shortages of renewable energy generation if it is not handled appropriately. In addition, extreme disasters, major epidemics, disasters and other emergencies also bring greater and more challenges to AI prediction techniques.
- 4) Shortage of high-tech talents related to AI techniques: AI techniques regarded as the essential new growth points for economic and social development, and all countries attach great importance to the development of AI techniques. The process of empowering AI techniques to large-scale renewable energy generation involves cross-composite knowledge of specific industry specialties and AI specialties, which requires more long-term layout at the talent training side, so as to make the trained talents familiar with the operational framework and critical crux of specific industries [153, 154]. However, there is currently a lack of composite talents with the knowledge system of AI techniques and renewable energy application. And the professional settings of universities have lagged behind the actual development of science and technology, and there are issues such as lack of practice, broad field, old knowledge and serious fragmentation in the professional teaching of AI techniques. Meanwhile, the industries have the issues of inadequate talent employment and incentive mechanism, lack of effective measures on how to evaluate

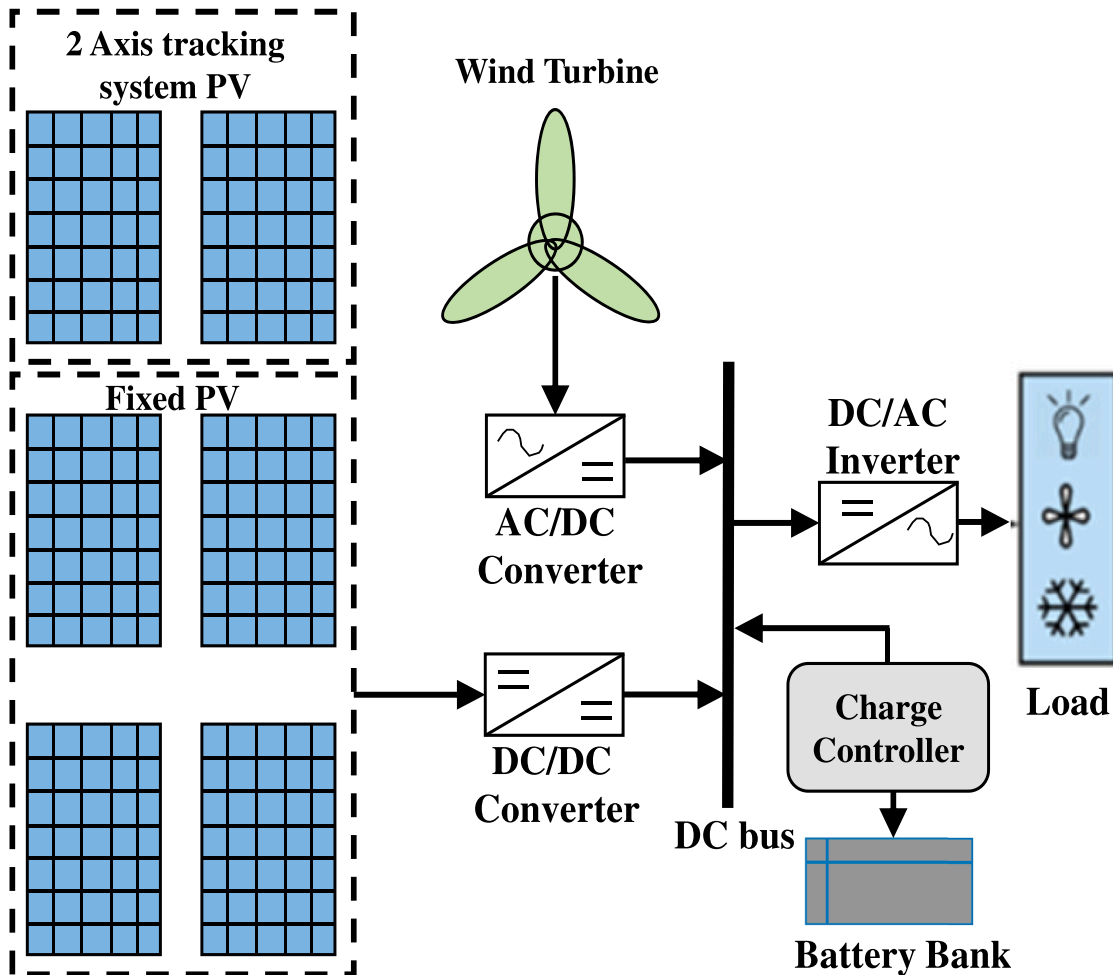

Fig. 18. Diagram of the studied microgrid system [132].

the contribution of scientific and technical personnel, and no effective incentives for the selection, appointment, training and employment of AI skilled personnel [155].

- 5) Lack of a maturing financial support system: The application of AI techniques in large-scale renewable energy generation is still immature, and there is still a lack of scientific and reasonable financial support policies [156, 157]. This is specifically reflected in the fact that a more comprehensive and deeper penetration of AI techniques into large-scale RES requires a large number of skilled professionals with sufficient AI and corresponding supporting funds to facilitate this transformation, but the AI-enabled energy market is currently lacking in both of them. In addition, the deployment of AI techniques in RES involves the production, improvement and management of software, which will likewise involve significant funding and capital. Therefore, the lack of a well-established financial support system is also one of the critical challenges affecting the application of AI techniques in RES.

## 5. Outlook and recommendations

In recent years, the proportion of renewable energy generation used in power grids has been increasing, which has contributed significantly to the reduction of carbon emissions worldwide [7, 158]. However, numerous studies have shown that the renewable energy generation will make the grid highly volatile due to the massive application of intermittent and fluctuated renewable energy (such as wind and solar energy). Therefore, reasonable operation methods of renewable energy generation equipment are required to achieve automated system control

and improve the automation with grid intelligence [29, 159]. It is important to actively promote new intelligent infrastructures to reduce energy consumption and measures that are consistent with sustainable development of AI techniques to reduce grid instability. The maintenance of grid stability using infrastructure-based solutions requires years of planning and construction, as well as significant capital expenditures. It would be a wrong move forward to install investments in a centralized grid with more transformer system infrastructures. Instead, governments would be required to make plans for a smart regional grid that is self-generated by communities and buildings, as well as being managed in real-time through an intelligent software platform.

A large number of energy storage equipment or systems are required for equalization in practical applications to effectively decrease the grid fluctuation and improve its longevity. By mitigating the intermittency issues faced by renewable energy sources, energy storage technologies could contribute to removing the barriers that prevent the increased adoption of wind and solar resources. ESS could not only support a peak-hour operating grid, but also maintain the existing grid infrastructure without the risk of grid overload and collapse [160, 161]. However, using the traditional centralized model of energy storage would not only be costly, but could also be a source of risk within the cities (e.g., fire catastrophe or explosion). Based on this, if the building is combined with distributed smart energy storage devices, it would not only solve the issue of energy storage in the building itself, but also make a great contribution to creating a safe urban smart grid [68, 162]. For example, the efficiency and reliability of PV power generation can be further improved by better matching PV with flexible direct current technology under advanced intelligent control technologies.

As a transportable energy storage device with great potential, electric vehicles are increasingly being widely used by consumers. The average storage capacity of each electric vehicle on the market today is about 60 kWh [163], which indicates that electric vehicles will have a huge amount of storage capacity if they could be reasonably connected to the grid [164, 165]. These storage capacities could be deployed through smart technologies to enable reliable grid operation. For example, by using the community's distributed energy microgrid and electric vehicle energy storage to form a "micro-energy intelligent system", all electric vehicles parked in the community could be automatically charged at a low cost during valley or sub-valley periods [166]. During the peak period, the electricity stored in electric vehicles could be sold to the grid through the V2G interaction, so as to enable vehicle owners obtain economic benefits under the peak-to-valley price differences [167, 168]. This intelligent control method on building load shifting under peak shaving and valley filling can regulate the energy consumption of the grid and bring extra economic profits to electric vehicle owners. If there is a sudden power outage in the community or the local power system suffers from attack, these electric vehicles could be used as a temporary power supply for each household through the intelligent control hub. In this way, such a residential intelligent community is actually a power generation unit, and also a very resilient virtual power plant.

In addition, policymakers are highly recommended to consider public financing issues for renewable energy generation in order to effectively promote regional decarbonization ambition. The economic investors only participate in the projects only when they can obtain sufficient economic benefits. Moreover, it is necessary to provide enough incentives to call for strong participation willingness of households and private enterprises with energy subsidies [169–171]. Furthermore, industry-approved AI-software management platforms would also need to be developed to ensure interoperability, transparency and equality across the renewable energy generation sector. Based on this, consistent data standards and data sharing mechanisms should be established to improve the quality of monitoring data and make them more available and controllable.

## 6. Conclusions

With the growing global climate and environmental challenges, the energy transition of using clean renewable energy instead of traditional fossil energy has already emerged as the prevailing trend. However, the adverse implications of large-scale renewable energy applications, including safety & stability and economical operation, are becoming more prominent. AI techniques with unique advantages in automation, intelligent identification, monitoring and management have been widely recognized in the existing studies. With the assistance of AI techniques, the applications of large-scale RES can be increasingly rational and intelligent, which paves a promising pathway for promoting their large-scale implementations. This paper presented a comprehensive literature summarization and analysis on the applications of AI techniques in large integration of renewable energy, including commonly used approaches, advantages and functional roles of AI techniques, prospective applications, and bottleneck technology challenges, etc.

Numerous studies have demonstrated that AI techniques can contribute to the accurate performance prediction of large-scale RES, as well as to reasonable energy distribution and control optimization of integrated systems. These enable to achieve the targets of matching customers' energy demands, cost-effectiveness and improvement of renewable energy utilization as well as minimizing environmental impact. However, there are also many issues and challenges with AI techniques in large-scale renewable energy applications, such as slow integration and updating of intelligent devices and limitations of advanced algorithms for AI techniques. Also, forecasting techniques to predict complicated real processes are also lacking, such as extreme

disasters, major epidemics and catastrophes. In addition, the shortage of AI-related technical professionals and unavailability of a sophisticated financial support system are also essential factors affecting its rapid development. To address these issues, this paper also presents several promising perspectives and recommendations for future studies. Using AI techniques to facilitate the optimal integration of advanced ESS, energy communities, electric vehicles, and other technologies with large-scale RES is the promising research framework. To promote applications of AI techniques in these fields, governments across countries are required to establish robust national energy strategic plans, reliable technical guidelines, and substantial financial incentives in the future.

## CRedit authorship contribution statement

**Zhengxuan Liu:** Conceptualization, Writing – original draft, Writing – review & editing, Formal analysis. **Ying Sun:** Writing – original draft, Writing – review & editing, Resources. **Chaojie Xing:** Writing – review & editing, Methodology. **Jia Liu:** Writing – review & editing, Methodology. **Yingdong He:** Writing – review & editing, Methodology. **Yuekuan Zhou:** Writing – review & editing, Supervision, Methodology. **Guoqiang Zhang:** Writing – review & editing, Supervision.

## Declaration of Competing Interest

The authors declare that they have no known competing financial interests or personal relationships that could have appeared to influence the work reported in this paper.

## Acknowledgements

All copyright licenses have been successfully applied for all cited graphics, images, tables and/or figures. This work was supported by the Hong Kong University of Science and Technology (Guangzhou) startup grant (G0101000059). This work was also supported in part by the Project of Hetao Shenzhen-Hong Kong Science and Technology Innovation Cooperation Zone (HZQB-KCZYB-2020083).

## References

- [1] Shafiullah GM, Oo AMT, Shawkat Ali ABM, Wolfs P. Potential challenges of integrating large-scale wind energy into the power grid—a review. *Renew Sustain Energy Rev* 2013;20:306–21.
- [2] Zhou Y, Zheng S, Liu Z, Wen T, Ding Z, Yan J, Zhang G. Passive and active phase change materials integrated building energy systems with advanced machine-learning based climate-adaptive designs, intelligent operations, uncertainty-based analysis and optimisations: a state-of-the-art review. *Renew Sustain Energy Rev* 2020;130:109889.
- [3] Zhou Y. Artificial neural network-based smart aerogel glazing in low-energy buildings: a state-of-the-art review. *iScience* 2021;24(12):103420.
- [4] Ahmad T, Zhu H, Zhang D, Tariq R, Bassam A, Ullah F, AlGhamdi AS, Alshamrani SS. Energetics systems and artificial intelligence: applications of industry 4.0. *Energy Rep* 2022;8:334–61.
- [5] Zhou Y, Cao S, Kosonen R, Hamdy M. Multi-objective optimisation of an interactive buildings-vehicles energy sharing network with high energy flexibility using the Pareto archive NSGA-II algorithm. *Energy Convers Manage* 2020;218:113017.
- [6] Zhou Y, Cao S, Hensen JLM, Hasan A. Heuristic battery-protective strategy for energy management of an interactive renewables–buildings–vehicles energy sharing network with high energy flexibility. *Energy Convers Manage* 2020;214:112891.
- [7] Liu Z, Xie M, Zhou Y, He Y, Zhang L, Zhang G, Chen D. A state-of-the-art review on shallow geothermal ventilation systems with thermal performance enhancement system classifications, advanced technologies and applications. *Energy Built Environ* 2021.
- [8] Liu Z, Zeng C, Zhou Y, Xing C. 9 - The main utilization forms and current developmental status of geothermal energy for building cooling/heating in developing countries (Eds.). In: Noorollahi Y, Naseer MN, Siddiqi MM, editors. *Utilization of thermal potential of abandoned wells*. Academic Press; 2022. p. 159–90.
- [9] Weschenfelder F, de Novaes Pires Leite G, Araújo da Costa AC, de Castro Vilela O, Ribeiro CM, Villa Ochoa AA, Araújo AM. A review on the complementarity between grid-connected solar and wind power systems. *J Clean Prod* 2020;257:120617.

- [10] Shafiullah GM, Arif MT, Oo AMT. Mitigation strategies to minimize potential technical challenges of renewable energy integration. *Sustain Energy Technol Assess* 2018;25:24–42.
- [11] Ram JP, Rajasekar N, Miyatake M. Design and overview of maximum power point tracking techniques in wind and solar photovoltaic systems: a review. *Renew Sustain Energy Rev* 2017;73:1138–59.
- [12] Alanazi M, Mahoor M, Khodaei A. Co-optimization generation and transmission planning for maximizing large-scale solar PV integration. *Int J Electr Power Energy Syst* 2020;118:105723.
- [13] Eltawil MA, Zhao Z. Grid-connected photovoltaic power systems: technical and potential problems—a review. *Renew Sustain Energy Rev* 2010;14(1):112–29.
- [14] Zhou Y, Cao S. Quantification of energy flexibility of residential net-zero-energy buildings involved with dynamic operations of hybrid energy storage and diversified energy conversion strategies. *Sustain Energy, Grids Netw* 2020;21: 100304.
- [15] Zhou Y, Cao S. Energy flexibility investigation of advanced grid-responsive energy control strategies with the static battery and electric vehicles: a case study of a high-rise office building in Hong Kong. *Energy Convers Manage* 2019;199: 111888.
- [16] Wang Y, Zou R, Liu F, Zhang L, Liu Q. A review of wind speed and wind power forecasting with deep neural networks. *Appl Energy* 2021;304:117766.
- [17] He Y, Zhou Y, Yuan J, Liu Z, Wang Z, Zhang G. Transformation towards a carbon-neutral residential community with hydrogen economy and advanced energy management strategies. *Energy Convers Manage* 2021;249:114834.
- [18] Li X, Wang W, Wang H. A novel bi-level robust game model to optimize a regionally integrated energy system with large-scale centralized renewable-energy sources in Western China. *Energy* 2021;228:120513.
- [19] He Y, Zhou Y, Wang Z, Liu J, Liu Z, Zhang G. Quantification on fuel cell degradation and techno-economic analysis of a hydrogen-based grid-interactive residential energy sharing network with fuel-cell-powered vehicles. *Appl Energy* 2021;303:117444.
- [20] Antonopoulos I, Robu V, Couraud B, Flynn D. Data-driven modelling of energy demand response behaviour based on a large-scale residential trial. *Energy AI* 2021;4:100071.
- [21] Zhou Y, Zheng S, Zhang G. Machine-learning based study on the on-site renewable electrical performance of an optimal hybrid PCM integrated renewable system with high-level parameters' uncertainties. *Renew Energy* 2020; 151:403–18.
- [22] Zhou Y, Zheng S. Machine-learning based hybrid demand-side controller for high-rise office buildings with high energy flexibilities. *Appl Energy* 2020;262:114416.
- [23] Hannan MA, Al-Shetwi AQ, Ker PJ, Begum RA, Mansor M, Rahman SA, Dong ZY, Tiong SK, Mahlia TMI, Muttaqui KM. Impact of renewable energy utilization and artificial intelligence in achieving sustainable development goals. *Energy Rep* 2021;7:5359–73.
- [24] Abdalla AN, Nazir MS, Tao H, Cao S, Ji R, Jiang M, Yao L. Integration of energy storage system and renewable energy sources based on artificial intelligence: an overview. *J Energy Storage* 2021;40:102811.
- [25] Elyasichamazkoti F, Khajepoor A. Application of machine learning for wind energy from design to energy-water nexus: a survey. *Energy Nexus* 2021;2: 100011.
- [26] He Q, Zheng H, Ma X, Wang L, Kong H, Zhu Z. Artificial intelligence application in a renewable energy-driven desalination system: a critical review. *Energy AI* 2022;7:100123.
- [27] Cheng L, Yu T. A new generation of AI: a review and perspective on machine learning technologies applied to smart energy and electric power systems. *Int J Energy Res* 2019;43(6):1928–73.
- [28] Hua W, Chen Y, Qadrdan M, Jiang J, Sun H, Wu J. Applications of blockchain and artificial intelligence technologies for enabling prosumers in smart grids: a review. *Renew Sustain Energy Rev* 2022;161:112308.
- [29] Ghadami N, Gheibi M, Kian Z, Faramarz MG, Naghedi R, Eftekhari M, Fathollahi-Fard AM, Dulebenets MA, Tian G. Implementation of solar energy in smart cities using an integration of artificial neural network, photovoltaic system and classical Delphi methods. *Sustain Cities Soc* 2021;74:103149.
- [30] Zhang H, Zhang X, Yuan J. Transition of China's power sector consistent with Paris Agreement into 2050: pathways and challenges. *Renew Sustain Energy Rev* 2020;132:110102.
- [31] Zhang R, Yan K, Li G, Jiang T, Li X, Chen H. Privacy-preserving decentralized power system economic dispatch considering carbon capture power plants and carbon emission trading scheme via over-relaxed ADMM. *Int J Electr Power Energy Syst* 2020;121:106094.
- [32] Chen X, Wu X, Lee KY. The mutual benefits of renewables and carbon capture: achieved by an artificial intelligent scheduling strategy. *Energy Convers Manage* 2021;233:113856.
- [33] Zhou Y. Energy sharing and trading on a novel spatiotemporal energy network in Guangdong-Hong Kong-Macao Greater Bay Area. *Appl Energy* 2022;318:119131.
- [34] Liu J, Zhou Y, Yang H, Wu H. Uncertainty energy planning of net-zero energy communities with peer-to-peer energy trading and green vehicle storage considering climate changes by 2050 with machine learning methods. *Appl Energy* 2022;321:119394.
- [35] Zhou Y. Transition towards carbon-neutral districts based on storage techniques and spatiotemporal energy sharing with electrification and hydrogenation. *Renew Sustain Energy Rev* 2022;162:112444.
- [36] Kebede AA, Kalogiannis T, Van Mierlo J, Berecibar M. A comprehensive review of stationary energy storage devices for large scale renewable energy sources grid integration. *Renew Sustain Energy Rev* 2022;159:112213.
- [37] Pupo-Roncillo O, Campillo J, Ingham D, Hughes K, Pourkashanian M. Large scale integration of renewable energy sources (RES) in the future Colombian energy system. *Energy* 2019;186:115805.
- [38] Brouwer AS, van den Broek M, Seebregts A, Faaij A. Impacts of large-scale intermittent renewable energy sources on electricity systems, and how these can be modeled. *Renew Sustain Energy Rev* 2014;33:443–66.
- [39] Voumvoulakis E, Asimakopoulou G, Danchev S, Maniatis G, Tsakanikas A. Large scale integration of intermittent renewable energy sources in the Greek power sector. *Energy Policy* 2012;50:161–73.
- [40] Ajagekar A, You F. Quantum computing and quantum artificial intelligence for renewable and sustainable energy: a emerging prospect towards climate neutrality. *Renew Sustain Energy Rev* 2022;165:112493.
- [41] Milidonis K, Blanco MJ, Grigoriev V, Panagiotou CF, Bonanos AM, Constantinou M, Pye J, Asselineau C-A. Review of application of AI techniques to solar tower systems. *Sol Energy* 2021;224:500–15.
- [42] Al-Othman F, Tawalbeh M, Martis R, Dhou S, Orhan M, Qasim M, Ghani Olabi A. Artificial intelligence and numerical models in hybrid renewable energy systems with fuel cells: advances and prospects. *Energy Convers Manage* 2022;253: 115154.
- [43] He Z, Guo W, Zhang P. Performance prediction, optimal design and operational control of thermal energy storage using artificial intelligence methods. *Renew Sustain Energy Rev* 2022;156:111977.
- [44] Kalogirou SA. Artificial neural networks in renewable energy systems applications: a review. *Renew Sustain Energy Rev* 2001;5(4):373–401.
- [45] Vijayalakshmi K, Vijayakumar K, Nandhakumar K. Prediction of virtual energy storage capacity of the air-conditioner using a stochastic gradient descent based artificial neural network. *Electric Power Syst Res* 2022;208:107879.
- [46] Mohanraj M, Jayaraj S, Muraleedharan C. Applications of artificial neural networks for refrigeration, air-conditioning and heat pump systems—a review. *Renew Sustain Energy Rev* 2012;16(2):1340–58.
- [47] Perera ATD, Wickramasinghe PU, Nik VM, Scartezzini J-L. Machine learning methods to assist energy system optimization. *Appl Energy* 2019;243:191–205.
- [48] Evin R. A review of computational optimisation methods applied to sustainable building design. *Renew Sustain Energy Rev* 2013;22:230–45.
- [49] Luo X, Liu Y, Liu X. Bi-level multi-objective optimization of design and subsidies for standalone hybrid renewable energy systems: a novel approach based on artificial neural network. *J Build Eng* 2021;41:102744.
- [50] Mahmoudi SM, Maleki A, Ochbelagh DRezaei. A novel method based on fuzzy logic to evaluate the storage and backup systems in determining the optimal size of a hybrid renewable energy system. *J Energy Storage* 2022;49:104015.
- [51] Suganthi L, Iniyar S, Samuel AA. Applications of fuzzy logic in renewable energy systems – a review. *Renew Sustain Energy Rev* 2015;48:585–607.
- [52] Ardehali MM, Saboori M, Teshnelab M. Numerical simulation and analysis of fuzzy PID and PSD control methodologies as dynamic energy efficiency measures. *Energy Convers Manage* 2004;45(13):1981–92.
- [53] Vigneysh T, Kumarappan N. Grid interconnection of renewable energy sources using multifunctional grid-interactive converters: a fuzzy logic based approach. *Electric Power Syst Res* 2017;151:359–68.
- [54] Cai YP, Huang GH, Yang ZF, Tan Q. Identification of optimal strategies for energy management systems planning under multiple uncertainties. *Appl Energy* 2009; 86(4):480–95.
- [55] Athari MH, Ardehali MM. Operational performance of energy storage as function of electricity prices for on-grid hybrid renewable energy system by optimized fuzzy logic controller. *Renew Energy* 2016;85:890–902.
- [56] Sibaliya TV. Particle swarm optimisation in designing parameters of manufacturing processes: a review (2008–2018). *Appl Soft Comput* 2019;84: 105743.
- [57] Khare A, Rangnekar S. A review of particle swarm optimization and its applications in solar photovoltaic system. *Appl Soft Comput* 2013;13(5): 2997–3006.
- [58] Alam S, Dobbie G, Koh YS, Riddle P, Ur Rehman S. Research on particle swarm optimization based clustering: a systematic review of literature and techniques. *Swarm Evol Comput* 2014;7:1–13.
- [59] García-Triviño P, Gil-Mena AJ, Llorens-Iborra F, García-Vázquez CA, Fernández-Ramírez LM, Jurado F. Power control based on particle swarm optimization of grid-connected inverter for hybrid renewable energy system. *Energy Convers Manage* 2015;91:83–92.
- [60] Lorestani A, Ardehali MM. Optimal integration of renewable energy sources for autonomous tri-generation combined cooling, heating and power system based on evolutionary particle swarm optimization algorithm. *Energy* 2018;145:839–55.
- [61] Nuvvula RSS, Devaraj E, Madurai Elavarasan R, Iman Taheri S, Irfan M, Teegala KS. Multi-objective mutation-enabled adaptive local attractor quantum behaved particle swarm optimisation based optimal sizing of hybrid renewable energy system for smart cities in India. *Sustain Energy Technol Assess* 2022;49: 101689.
- [62] Namilakonda S, Guduri Y. Chaotic Darwinian particle swarm optimization for real-time hierarchical congestion management of power system integrated with renewable energy sources. *Int J Electr Power Energy Syst* 2021;128:106632.
- [63] Tavares Neto RF, Filho MGodinho. Literature review regarding ant colony optimization applied to scheduling problems: guidelines for implementation and directions for future research. *Eng Appl Artif Intell* 2013;26(1):150–61.
- [64] Eroğlu Y, Seçkiner SU. Design of wind farm layout using ant colony algorithm. *Renew Energy* 2012;44:53–62.
- [65] Fetanat A, Khorasaninejad E. Size optimization for hybrid photovoltaic–wind energy system using ant colony optimization for continuous domains based integer programming. *Appl Soft Comput* 2015;31:196–209.



- [66] Ju L, Huang L, Lin H, Li H, Tan Z. An interactive dispatching strategy for micro energy grids considering multi-energy flexible conversion based on the three-level optimization perspective. *Sustain Cities Soc* 2021;64:102504.
- [67] Güven AF, Yörükören N, Samy MM. Design optimization of a stand-alone green energy system of university campus based on Jaya-Harmony search and ant colony optimization algorithms approaches. *Energy* 2022;253:124089.
- [68] Ali AO, Elmarghany MR, Abdelsalam MM, Sabry MN, Hamed AM. Closed-loop home energy management system with renewable energy sources in a smart grid: a comprehensive review. *J Energy Storage* 2022;50:104609.
- [69] Izadi A, Shahafve M, Ahmadi P. Neural network genetic algorithm optimization of a transient hybrid renewable energy system with solar/wind and hydrogen storage system for zero energy buildings at various climate conditions. *Energy Convers Manage* 2022;260:115593.
- [70] Chen B, Liu Q, Chen H, Wang L, Deng T, Zhang L, Wu X. Multiobjective optimization of building energy consumption based on BIM-DB and LSSVM-NSGA-II. *J Clean Prod* 2021;294:126153.
- [71] Bala BK, Siddique SA. Optimal design of a PV-diesel hybrid system for electrification of an isolated island—Sandwip in Bangladesh using genetic algorithm. *Energy Sustain Dev* 2009;13(3):137–42.
- [72] Mayer MJ, Szilágyi A, Gróf G. Environmental and economic multi-objective optimization of a household level hybrid renewable energy system by genetic algorithm. *Appl Energy* 2020;269:115058.
- [73] Zhang W, Maleki A, Rosen MA, Liu J. Optimization with a simulated annealing algorithm of a hybrid system for renewable energy including battery and hydrogen storage. *Energy* 2018;163:191–207.
- [74] Zhang G, Wu B, Maleki A, Zhang W. Simulated annealing-chaotic search algorithm based optimization of reverse osmosis hybrid desalination system driven by wind and solar energies. *Sol Energy* 2018;173:964–75.
- [75] Garlik B, Krivan M. Renewable energy unit commitment, with different acceptance of balanced power, solved by simulated annealing. *Energy Build* 2013;67:392–402.
- [76] Nadjemi O, Nacer T, Hamidat A, Salhi H. Optimal hybrid PV/wind energy system sizing: application of cuckoo search algorithm for Algerian dairy farms. *Renew Sustain Energy Rev* 2017;70:1352–65.
- [77] Makhloufi S, Khennas S, Bouchaib S, Arab AH. Multi-objective cuckoo search algorithm for optimized pathways for 75% renewable electricity mix by 2050 in Algeria. *Renew Energy* 2022;185:1410–24.
- [78] Garshasbi S, Kurnitski J, Mohammadi Y. A hybrid genetic algorithm and Monte Carlo simulation approach to predict hourly energy consumption and generation by a cluster of net zero energy buildings. *Appl Energy* 2016;179:626–37.
- [79] Najafian A, Haghghat F, Moreau A. Integration of PCM in domestic hot water tanks: optimization for shifting peak demand. *Energy Build* 2015;106:59–64.
- [80] Ren H, Ma Z, Lin W, Wang S, Li W. Optimal design and size of a desiccant cooling system with onsite energy generation and thermal storage using a multilayer perceptron neural network and a genetic algorithm. *Energy Convers Manage* 2019;180:598–608.
- [81] Cox SJ, Kim D, Cho H, Mago P. Real time optimal control of district cooling system with thermal energy storage using neural networks. *Appl Energy* 2019; 238:466–80.
- [82] Rangel-Martinez D, Nigam KDP, Ricardez-Sandoval LA. Machine learning on sustainable energy: a review and outlook on renewable energy systems, catalysis, smart grid and energy storage. *Chem Eng Res Des* 2021;174:414–41.
- [83] Shin W, Han J, Rhee W. AI-assistance for predictive maintenance of renewable energy systems. *Energy* 2021;221:119775.
- [84] Faritha Banu J, Atul Mahajan R, Sakthi U, Kumar Nassa V, Lakshmi D, Nadanakumar V. Artificial intelligence with attention based BiLSTM for energy storage system in hybrid renewable energy sources. *Sustain Energy Technol Assess* 2022;52:102334.
- [85] Zhu J, Dong H, Zheng W, Li S, Huang Y, Xi L. Review and prospect of data-driven techniques for load forecasting in integrated energy systems. *Appl Energy* 2022; 321:119269.
- [86] Sun Y, Haghghat F, Fung BCM. A review of the-state-of-the-art in data-driven approaches for building energy prediction. *Energy Build* 2020;221:110022.
- [87] Mahmoud MS, Alyazidi NM, Abouheaf MI. Adaptive intelligent techniques for microgrid control systems: a survey. *Int J Electr Power Energy Syst* 2017;90: 292–305.
- [88] Rostami A, Jalilian A, Naderi SB, Negnevitsky M, Davari P, Blaabjerg F. A novel passive islanding detection scheme for distributed generations based on rate of change of positive sequence component of voltage and current. *Australasian Universities Power Engineering Conference (AUPEC)*; 2017. p. 1–5. 2017.
- [89] Panigrahi BK, Bhuyan A, Shukla J, Ray PK, Pati S. A comprehensive review on intelligent islanding detection techniques for renewable energy integrated power system. *Int J Energy Res* 2021;45(10):14085–116.
- [90] Memon MA, Mekhilef S, Mubin M, Aamir M. Selective harmonic elimination in inverters using bio-inspired intelligent algorithms for renewable energy conversion applications: a review. *Renew Sustain Energy Rev* 2018;82:2235–53.
- [91] Acharya PS. Intelligent algorithmic multi-objective optimization for renewable energy system generation and integration problems: a review. *Int J Renew Energy Res* 2019;9(1):271–80.
- [92] Blaabjerg F, Yang Y, Ma K, Wang X. Power electronics—the key technology for renewable energy system integration. In: 2015 international conference on renewable energy research and applications (ICRERA). IEEE; 2015. p. 1618–26.
- [93] Šerban AC, Lytras MD. Artificial intelligence for smart renewable energy sector in Europe—smart energy infrastructures for next generation smart cities. *IEEE Access* 2020;8:77364–77.
- [94] Caballero F, Sauma E, Yanine F. Business optimal design of a grid-connected hybrid PV (photovoltaic)-wind energy system without energy storage for an Easter Island's block. *Energy* 2013;61:248–61.
- [95] Mercado KD, Jiménez J, Quintero MCG. Hybrid renewable energy system based on intelligent optimization techniques. In: 2016 IEEE international conference on renewable energy research and applications (ICRERA). IEEE; 2016. p. 661–6.
- [96] Al-falahi MDA, Jayasinghe SDG, Enshaei H. A review on recent size optimization methodologies for standalone solar and wind hybrid renewable energy system. *Energy Convers Manage* 2017;143:252–74.
- [97] Liu L, Zhao Y, Chang D, Xie J, Ma Z, Sun Q, Yin H, Wennersten R. Prediction of short-term PV power output and uncertainty analysis. *Appl Energy* 2018;228: 700–11.
- [98] Hu K, Cao S, Wang L, Li W, Lv M. A new ultra-short-term photovoltaic power prediction model based on ground-based cloud images. *J Clean Prod* 2018;200: 731–45.
- [99] Li L-L, Wen S-Y, Tseng M-L, Wang C-S. Renewable energy prediction: a novel short-term prediction model of photovoltaic output power. *J Clean Prod* 2019; 228:359–75.
- [100] Xia M, Shao H, Ma X, Silva CWd. A stacked GRU-RNN-based approach for predicting renewable energy and electricity load for smart grid operation. *IEEE Trans Ind Inf* 2021;17(10):7050–9.
- [101] Shamsi M, Cuffe P. Prediction markets for probabilistic forecasting of renewable energy sources. *IEEE Trans Sustain Energy* 2022;13(2):1244–53.
- [102] Ku YJ, Sapra S, Baidya S, Dey S. State of energy prediction in renewable energy-driven mobile edge computing using CNN-LSTM networks. In: 2020 IEEE green energy and smart systems conference (IGESSC); 2020. p. 1–7.
- [103] Ahmad T, Zhang H, Yan B. A review on renewable energy and electricity requirement forecasting models for smart grid and buildings. *Sustain Cities Soc* 2020;55:102052.
- [104] Del Ser J, Casillas-Perez D, Cornejo-Bueno L, Prieto-Godino L, Sanz-Justo J, Casanova-Mateo C, Salcedo-Sanz S. Randomization-based machine learning in renewable energy prediction problems: critical literature review, new results and perspectives. *Appl Soft Comput* 2022;118:108526.
- [105] Lai J-P, Chang Y-M, Chen C-H, Pai P-F. A survey of machine learning models in renewable energy predictions. *Appl Sci* 2020;10(17):5975.
- [106] Bhutto AW, Bazmi AA, Zahedi G. Greener energy: issues and challenges for Pakistan—Wind power prospective. *Renew Sustain Energy Rev* 2013;20:519–38.
- [107] Bhutto AW, Bazmi AA, Zahedi G. Greener energy: issues and challenges for Pakistan—solar energy prospective. *Renew Sustain Energy Rev* 2012;16(5): 2762–80.
- [108] Basak P, Chowdhury S, Halder nee Dey S, Chowdhury SP. A literature review on integration of distributed energy resources in the perspective of control, protection and stability of microgrid. *Renew Sustain Energy Rev* 2012;16(8): 5545–56.
- [109] Choudhury S. Review of energy storage system technologies integration to microgrid: types, control strategies, issues, and future prospects. *J Energy Storage* 2022;48:103966.
- [110] Mohamed AAS, Metwally H, El-Sayed A, Selem SI. Predictive neural network based adaptive controller for grid-connected PV systems supplying pulse-load. *Sol Energy* 2019;193:139–47.
- [111] Nageswara Rao G, Sangameswara Raju P, Chandra Sekhar K. Harmonic elimination of cascaded H-bridge multilevel inverter based active power filter controlled by intelligent techniques. *Int J Electr Power Energy Syst* 2014;61: 56–63.
- [112] Rahmani A, Deihimi A. Reduction of harmonic monitors and estimation of voltage harmonics in distribution networks using wavelet analysis and NARX. *178. Electric Power Systems Research*; 2020. 106046.
- [113] Chandio AA, Laghari JA, Khokhar S, Almani SA. A new islanding detection technique based on rate of change of reactive power and radial basis function neural network for distributed generation. *J Intellig Fuzzy Syst* 2019;37:2169–79.
- [114] Anjaiah K, Dash PK, Sahani M. Detection of faults and DG islanding in PV-Wind DC ring bus microgrid by using optimized VMD based improved broad learning system. *ISA Trans* 2022.
- [115] Liang Z, Mu L, Zhang F, Zhou H, Zhang X. The fault detection method of islanded microgrid with the V/f controlled distributed generation. *Int J Electr Power Energy Syst* 2019;112:28–35.
- [116] Mahfouz MMA. A protection scheme for multi-distributed smart microgrid based on auto-cosine similarity of feeders current patterns. *Electric Power Syst Res* 2020;186:106405.
- [117] Mohapatra SS, Maharana MK, Pradhan A, Panigrahi PK, Prusty RC. Detection and diagnosis of islanding using artificial intelligence in distributed generation systems. *Sustain Energy, Grids Netw* 2022;29:100576.
- [118] Darab C, Tarnovan R, Turcu A, Martineac C. Artificial intelligence techniques for fault location and detection in distributed generation power systems. In: 2019 8th international conference on modern power systems (MPS); 2019. p. 1–4.
- [119] Ge B, Wang W, Bi D, Rogers CB, Peng FZ, de Almeida AT, Abu-Rub H. Energy storage system-based power control for grid-connected wind power farm. *Int J Electr Power Energy Syst* 2013;44(1):115–22.
- [120] Aragón G, Pandian V, Krauß V, Werner-Kytölä O, Thybo G, Pautasso E. Feasibility and economical analysis of energy storage systems as enabler of higher renewable energy sources penetration in an existing grid. *Energy* 2022;251:123889.
- [121] Aktas A, Erhan K, Özdemir S, Özdemir E. Dynamic energy management for photovoltaic power system including hybrid energy storage in smart grid applications. *Energy* 2018;162:72–82.



- [122] Nazir MS, Wang Y, Bilal M, Sohaiil HM, Kadhem AA, Nazir HMR, Abdalla AN, Ma Y. Comparison of small-scale wind energy conversion systems: economic indexes. *Clean Technol* 2020;2(2):144–55.
- [123] Zhou D, Al-Durra A, Zhang K, Ravey A, Gao F. A robust prognostic indicator for renewable energy technologies: a novel error correction grey prediction model. *IEEE Trans Ind Electron* 2019;66(12):9312–25.
- [124] Zangeneh M, Aghajari E, Forouzanfar M. Design and implementation of an intelligent multi-input multi-output Sugeno fuzzy logic controller for managing energy resources in a hybrid renewable energy power system based on Arduino boards. *Soft comput* 2022;26(3):1459–73.
- [125] Kermani M, Adelmanesh B, Shirdare E, Sima CA, Carni DL, Martirano L. Intelligent energy management based on SCADA system in a real Microgrid for smart building applications. *Renew Energy* 2021;171:1115–27.
- [126] Fikiin K, Stankov B, Evans J, Maidment G, Foster A, Brown T, Radcliffe J, Youbi-Idrissi M, Alford A, Varga L, Alvarez G, Ivanov IE, Bond C, Colombo I, Garcia-Naveda G, Ivanov I, Hattori K, Umeki D, Bojkov T, Kaloyanov N. Refrigerated warehouses as intelligent hubs to integrate renewable energy in industrial food refrigeration and to enhance power grid sustainability. *Trends Food Sci Technol* 2017;60:96–103.
- [127] Wang Z, Srinivasan RS. A review of artificial intelligence based building energy use prediction: contrasting the capabilities of single and ensemble prediction models. *Renew Sustain Energy Rev* 2017;75:796–808.
- [128] Deb C, Zhang F, Yang J, Lee SE, Shah KW. A review on time series forecasting techniques for building energy consumption. *Renew Sustain Energy Rev* 2017;74:902–24.
- [129] Bourdeau M, Zhai Xq, Nefzaoui E, Guo X, Chatellier P. Modeling and forecasting building energy consumption: a review of data-driven techniques. *Sustain Cities Soc* 2019;48:101533.
- [130] Wei N, Li C, Peng X, Zeng F, Lu X. Conventional models and artificial intelligence-based models for energy consumption forecasting: a review. *J Pet Sci Eng* 2019;181:106187.
- [131] Shah T, Ansari ZA. An overview of intelligent energy management system for DC microgrid: system and communication architecture and application in power distribution system. In: 2018 IEEE 13th international conference on industrial and information systems (ICIIS); 2018. p. 1–4.
- [132] Hadi AA, Silva CAS, Hossain E, Chaloo R. Algorithm for demand response to maximize the penetration of renewable energy. *IEEE Access* 2020;8:55279–88.
- [133] Javaid N, Ullah I, Akbar M, Iqbal Z, Khan FA, Alrajeh N, Alabed MS. An intelligent load management system with renewable energy integration for smart homes. *IEEE Access* 2017;5:13587–600.
- [134] Ma Y, Li B. Hybridized intelligent home renewable energy management system for smart Grids. *Sustainability* 2020;12(5):2117.
- [135] Ameur C, Faquir S, Yahyaouy A. Intelligent optimization and management system for renewable energy systems using multi-agent. *IAES Int J Artif Intellig* 2019;8:352–9.
- [136] Zhou Y, Cao S, Hensen JLM. An energy paradigm transition framework from negative towards positive district energy sharing networks—battery cycling aging, advanced battery management strategies, flexible vehicles-to-buildings interactions, uncertainty and sensitivity analysis. *Appl Energy* 2021;288:116606.
- [137] Zhou Y, Cao S. Coordinated multi-criteria framework for cycling aging-based battery storage management strategies for positive building-vehicle system with renewable depreciation: life-cycle based techno-economic feasibility study. *Energy Convers Manage* 2020;226:113473.
- [138] Tan KM, Ramachandaramurthy VK, Yong JY. Integration of electric vehicles in smart grid: a review on vehicle to grid technologies and optimization techniques. *Renew Sustain Energy Rev* 2016;53:720–32.
- [139] Islam S, Iqbal A, Marzband M, Khan I, Al-Wahedi AMAB. State-of-the-art vehicle-to-everything mode of operation of electric vehicles and its future perspectives. *Renew Sustain Energy Rev* 2022;166:112574.
- [140] Solanke TU, Ramachandaramurthy VK, Yong JY, Pasupuleti J, Kasinathan P, Rajagopalan A. A review of strategic charging-discharging control of grid-connected electric vehicles. *J Energy Storage* 2020;28:101193.
- [141] Shi Z, Yao W, Li Z, Zeng L, Zhao Y, Zhang R, Tang Y, Wen J. Artificial intelligence techniques for stability analysis and control in smart grids: methodologies, applications, challenges and future directions. *Appl Energy* 2020;278:115733.
- [142] Feng C, Liu Y, Zhang J. A taxonomical review on recent artificial intelligence applications to PV integration into power grids. *Int J Electr Power Energy Syst* 2021;132:107176.
- [143] Ahmad T, Zhang D, Huang C, Zhang H, Dai N, Song Y, Chen H. Artificial intelligence in sustainable energy industry: status quo, challenges and opportunities. *J Clean Prod* 2021;289:125834.
- [144] Li J, Samavatian V. Energy management for a grid-connected PV-inverter with a novel power loss mitigation functionality in distributed networks. *Comput Electrical Eng* 2020;87:106769.
- [145] Hassan Z, Amir A, Selvaraj J, Rahim NA. A review on current injection techniques for low-voltage ride-through and grid fault conditions in grid-connected photovoltaic system. *Sol Energy* 2020;207:851–73.
- [146] Li Z, Liu Z, Zhang Y, Zhang H, Fu D. Research on resilience assessment and disaster prevention strategy of active distribution network. *Energy Rep* 2021;7:734–49.
- [147] Tümay M, Demirdelen T, Bal S, Kayaalp Rİ, Doğru B, Aksoy M. A review of magnetically controlled shunt reactor for power quality improvement with renewable energy applications. *Renew Sustain Energy Rev* 2017;77:215–28.
- [148] Eslami A, Negnevitsky M, Franklin E, Lyden S. Review of AI applications in harmonic analysis in power systems. *Renew Sustain Energy Rev* 2022;154:111897.
- [149] Boza P, Evgeniou T. Artificial intelligence to support the integration of variable renewable energy sources to the power system. *Appl Energy* 2021;290:116754.
- [150] Zhou Y. Chapter 8 - advanced renewable dispatch with machine learning-based hybrid demand-side controller: the state of the art and a novel approach (Eds.). In: Kumar K, Rao RS, Kaiwartya O, Kaiser MS, Padmanaban S, editors. Sustainable developments by artificial intelligence and machine learning for renewable energies. Elsevier; 2022. p. 237–56.
- [151] Zhou Y. Chapter 9 - a machine learning-based design approach on PCMs-PV systems with multilevel scenario uncertainty (Eds.). In: Kumar K, Rao RS, Kaiwartya O, Kaiser MS, Padmanaban S, editors. Sustainable developments by artificial intelligence and machine learning for renewable energies. Elsevier; 2022. p. 257–72.
- [152] Zhou Y, Zheng S. Multi-level uncertainty optimisation on phase change materials integrated renewable systems with hybrid ventilations and active cooling. *Energy* 2020;202:117747.
- [153] Kow KW, Wong YW, Rajkumar Rajparthiban K, Rajkumar RK. A review on performance of artificial intelligence and conventional method in mitigating PV grid-tied related power quality events. *Renew Sustain Energy Rev* 2016;56:334–46.
- [154] Smith G. The intelligent solution: automation, the skills shortage and cybersecurity. *Comput Fraud Secur* 2018;2018(8):6–9.
- [155] Wolsink M. Distributed energy systems as common goods: socio-political acceptance of renewables in intelligent microgrids. *Renew Sustain Energy Rev* 2020;127:109841.
- [156] Matschoss P, Bayer B, Thomas H, Marian A. The German incentive regulation and its practical impact on the grid integration of renewable energy systems. *Renew Energy* 2019;134:727–38.
- [157] Cubric M. Drivers, barriers and social considerations for AI adoption in business and management: a tertiary study. *Technol Soc* 2020;62:101257.
- [158] Zhou Y, Cao S, Hensen JLM, Lund PD. Energy integration and interaction between buildings and vehicles: a state-of-the-art review. *Renew Sustain Energy Rev* 2019;114:109337.
- [159] Zahraee SM, Khalaji Assadi M, Saidur R. Application of artificial intelligence methods for hybrid energy system optimization. *Renew Sustain Energy Rev* 2016;66:617–30.
- [160] Han G, Lee S, Lee J, Lee K, Bae J. Deep-learning- and reinforcement-learning-based profitable strategy of a grid-level energy storage system for the smart grid. *J Energy Storage* 2021;41:102868.
- [161] Nandkeolyar S, Ray PK. Multi objective demand side storage dispatch using hybrid extreme learning machine trained neural networks in a smart grid. *J Energy Storage* 2022;51:104439.
- [162] Casini M, Casini M. Chapter 12 - smart buildings and smart cities (Ed.). *Construction 4.0*. Woodhead Publishing; 2022. p. 607–60.
- [163] Useable battery capacity of full electric vehicles, electric vehicle database. <https://ev-database.org/cheatsheet/useable-battery-capacity-electric-car> (accessed Apr. 10, 2022).
- [164] Ahmed M, Zheng Y, Amine A, Fathiannasab H, Chen Z. The role of artificial intelligence in the mass adoption of electric vehicles. *Joule* 2021;5(9):2296–322.
- [165] Meng K, Xu G, Peng X, Youcef-Toumi K, Li J. Intelligent disassembly of electric-vehicle batteries: a forward-looking overview. *Resour, Conserv Recycl* 2022;182:106207.
- [166] Martínez Ceseña EA, Mancarella P. 8 - Smart distribution networks, demand side response, and community energy systems: field trial experiences and smart grid modeling advances in the United Kingdom. Eds.. In: Lamont LA, Sayigh A, editors. *Application of smart grid technologies*. Academic Press; 2018. p. 275–311.
- [167] Liu G, Jiang T, Ollis TB, Zhang X, Tomovic K. Distributed energy management for community microgrids considering network operational constraints and building thermal dynamics. *Appl Energy* 2019;239:83–95.
- [168] Zhou F, Li Y, Wang W, Pan C. Integrated energy management of a smart community with electric vehicle charging using scenario based stochastic model predictive control. *Energy Build* 2022;260:111916.
- [169] Löbner M, Böttger D, Bruckner T. Economic assessment of virtual power plants in the German energy market — a scenario-based and model-supported analysis. *Energy Economics* 2017;62:125–38.
- [170] Yu F, Wang L, Li X. The effects of government subsidies on new energy vehicle enterprises: the moderating role of intelligent transformation. *Energy Policy* 2020;141:111463.
- [171] Wang L, Ma Y, Zhu L, Wang X, Cong H, Shi T. Design of integrated energy market cloud service platform based on blockchain smart contract. *Int J Electr Power Energy Syst* 2022;135:107515.