

\*

**Disassembly assessment framework for enhanced reclamation of  
façade systems.**

**Author**

Sarah Droste

5584655

MSc Architecture, Urbanism and Building Sciences





Source: Author



# Building Technology Graduation Report

## ***Author***

Sarah Droste

5584655

MSc Architecture, Urbanism and Building Sciences

## ***Studio***

Building Technology Graduation Studio

## ***First Mentor***

Prof. dr. Mauro Overend

AE + T | Structural Design & Mechanics

## ***Second Mentor***

Dr. ing. Marcel Bilow

AE + T | Façade & Products Innovation

## ***Delegate of the Board of Examiners***

Dr. Arie Romein

## ***Date***

10. November, 2023.





# Acknowledgements

This thesis signifies the culmination of my academic journey at Delft University of Technology. Through the Building Technology program, I have gained many new skills that allow me to make a contribution in the global effort of creating a more sustainable built environment. I am thankful for the experiences I had and the great individuals I have encountered along the way.

This accomplishment would not have been achievable without the generous support and motivation from my mentors, Mauro Overend and Marcel Bilow, who kindly offered their time, expertise, and guidance over the past months. Their encouragement and empathy was pivotal in the process of concluding my project.

I am profoundly grateful to Rebecca Hartwell for her insights and the time she devoted during crucial moments of this journey. Each discussion and meeting with her was a moment of delight, and enriched my understanding and progress.

I would like to extend my gratitude to Maria Meizoso for helping me on a professional level, for providing the case study for this project, and for sharing her perspective on the topic. Furthermore, Finn Krijger, Stijn van den Berg, and the team at Octatube Services, who were present throughout the entire process. I am truly thankful for the uplifting and enriching working atmosphere at Octatube Services.

A heartfelt thanks to my friends from the Dominican Republic and Bulgaria, as well as the amazing new friends I have made during my studies in the Netherlands. Thank you for being my support during the ups and the downs, and the not-so-amazing weather. Thank you for all the laughter and the fun times that made these past two years so enjoyable. A special thanks to Patrick, for constantly being there to support me in moments of uncertainty.

This thesis is dedicated to my entire family, both in the Dominican Republic and in Germany. My parents and siblings, for their unconditional love and support that always kept me motivated to continue, even in the most difficult times, and for always making sure that I took my vitamins.

To all mentioned and more, mere words fall short to capture my appreciation.

Thank you all,  
Sarah





# Abstract

One of the major technological challenges in achieving circularity within the built environment is the disassembly of multi-material systems at the end of their useful life. This is especially true for façade systems, which have become more complex to improve operational performance. As efforts to reduce embodied carbon in façade systems intensify, circular economy principles, which integrate design, maintenance, and product reclamation to minimize waste and emissions, are crucial. A significant aspect of this is the emphasis on Design for Disassembly (DfD) strategies.

Yet, despite the critical importance of circular economy principles, there is a disconnect between the awareness of stakeholders in the façade industry and the evaluative methods used to assess the impact of DfD during the early design stages on the material reclamation potential at the end of a building product's lifecycle. Industry stakeholders emphasize the need for quantitative methods to determine how design choices affect reclamation potential. Thus, developing a disassembly assessment framework is essential to guide DfD efforts in façade systems and to predict outcomes at their end of life. This study seeks to address this issue by developing a framework that meets the façade industry's needs, emphasizing the evaluation of design choices on material reclamation.

By reviewing relevant literature, various factors that impact the highest reclamation potential for a façade systems were identified. These factors were organized into process maps, laying the groundwork for potential computational workflows. The factors were organized into modules that, when combined, facilitate a consistent assessment process. This research revealed that much of the necessary information is not readily processed by computational tools; it often exists in unstructured formats like text documents, and the key decision-making factors are often subjective and require human judgement. As a result, this framework proposes steps to creating databases which could improve the assessment process.

The framework's effectiveness is demonstrated through a case study of an aluminum curtain wall façade system. The assessment led to suggested design improvements that increase the potential for material recovery and reduce disassembly time at the end of life. This case study demonstrates the framework's utility and uncovers practical challenges and opportunities, serving as a model for adapting the framework to different façade typologies and building components.

## **Keywords:**

Design for Disassembly, Façade, End of Life, Circular Economy, Disassembly Assessment Framework, Reclamation Potential, Disassembly Potential

# Table of Contents

<b>1</b>	<b>Introduction</b>	<b>09</b>
<b>2</b>	<b>Research Framework</b>	<b>12</b>
2.1	Problem Statement	13
2.2	Research Questions	14
2.3	Research Objectives	14
2.4	Research Methodology	15
2.5	Limitations	17
2.6	Abbreviations & Definitions	17
<b>3</b>	<b>Circular Façade Economy</b>	<b>18</b>
3.1	Circular Economy in the Built Environment	19
3.2	Focus on Design for Disassembly	24
3.3	Typical End of Life of Curtain Wall Façade Systems	27
3.4	Material Flows	30
3.5	Circular Lifecycle of Building Façades	36
3.6	Digital Tools in the Circular Façade Economy	40
3.7	Conclusions	44
<b>4</b>	<b>Measuring Disassembly</b>	<b>46</b>
4.1	Measuring the Circular Economy	47
4.2	Existing Circularity Indicators	48
4.3	Disassembly Potential	50
4.4	Disassembly Time	52
4.5	Environmental Indicators	54
4.6	Comparing Different Indicators	57
4.7	Disassembly Mapping and Relational Diagrams	59
4.8	Conclusions	61
<b>5</b>	<b>Conceptual Framework</b>	<b>62</b>
5.1	Introduction	63
5.2	Stakeholder Collaboration	65
5.3	Information Input	66
5.4	Information Model	67
5.5	Databases	69
5.6	Conclusion	70



---

<b>6</b>	<b>Assessment Modules</b>	<b>72</b>
6.1	Introduction	73
6.2	Selected Assessment Criteria	74
6.3	Process Map	75
6.4	Façade Typology Selection	76
6.5	Disassembly Potential	77
6.6	Reclamation Potential	79
6.7	Disassembly Time	82
6.8	Reuse	84
6.9	Remanufacturing	87
6.10	Recyclability	88
6.11	Conclusions	89
<b>7</b>	<b>Framework Demonstration</b>	<b>91</b>
7.1	Case Study	92
7.2	Identification of Façade Instances based on Levels	95
7.3	Materials Database	96
7.4	Process Database	99
7.5	Connection Database	100
7.6	Disassembly Potential	101
7.7	Reclamation Potential	102
7.8	Disassembly Time	104
7.9	Comparison Scenarios	107
7.10	Design Improvement	109
7.11	User Output	110
<b>8</b>	<b>Conclusions</b>	<b>111</b>
8.1	Conclusions	112
8.2	Answering Research Questions	113
8.3	Limitations and Recommendations	116
8.4	Opportunities and Further Research	117
<b>9</b>	<b>References</b>	<b>118</b>
9.1	References	119
<b>10</b>	<b>Appendix</b>	<b>124</b>





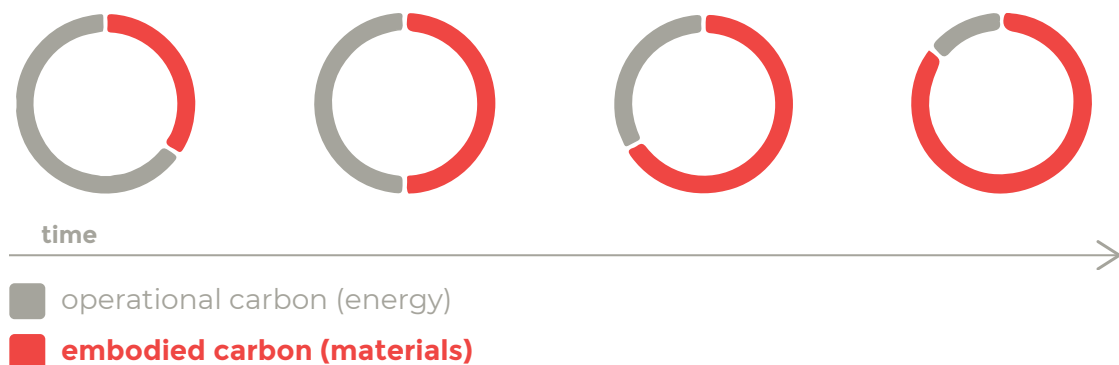
# 1 Introduction

The construction sector is a significant contributor to global environmental concerns, consuming around 50% of global resources, producing 25% of all waste (Ellen MacArthur Foundation, 2013), being responsible for nearly 40% of global energy consumption and about 38% of global carbon emissions (European Environment Agency, 2022). Reducing carbon emissions has been the main focus of sustainability goals. Carbon emissions are generated throughout a building's lifespan (Carbon Leadership Forum, 2020). Material extraction, manufacturing, construction, and the end of life (EoL) handling and processing represent the embodied carbon (Figure 1.1). The carbon emissions from building operations and maintenance are known as the operational carbon emissions of a building.



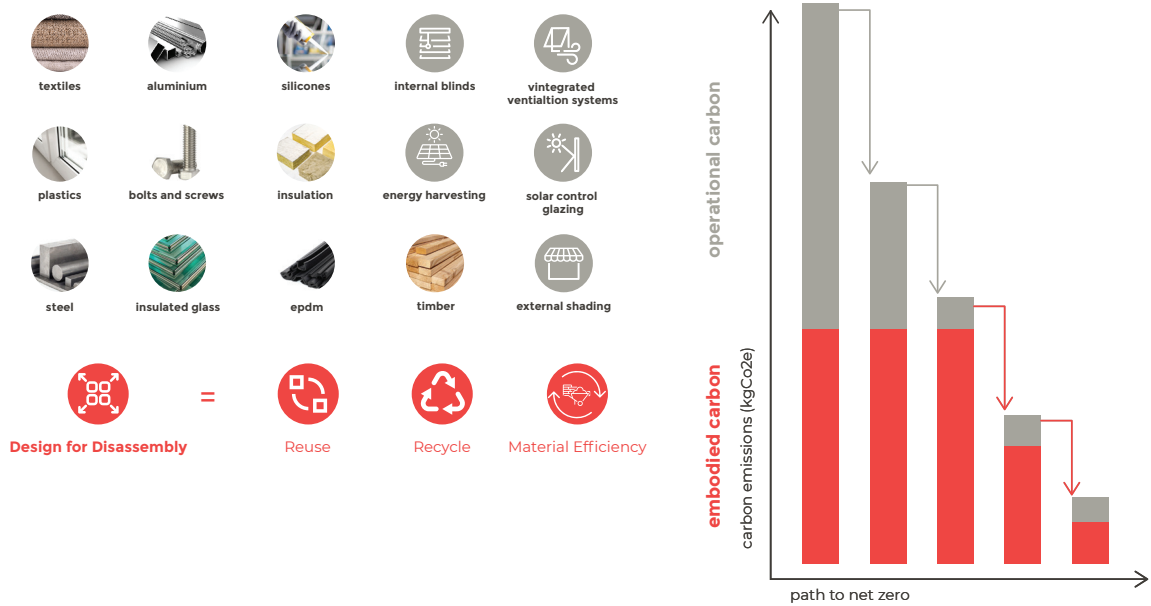
**Figure 1.1.** Embodied Carbon (yellow) and operational carbon (blue) across building life cycle. (Carbon Leadership Forum, 2020)

Modern buildings allocate up to 25% of their carbon footprint to façades, despite their shorter lifespan. Common reasons for replacing façades, thus a shorter lifespan, include performance issues, aesthetics, and energy-efficiency upgrades (Hartwell et al., 2021). As operational carbon decreases, embodied carbon's importance grows, especially in complex façade systems (Chastas et al., 2017).



**Figure 1.2.** Embodied Carbon rises as Operational Carbon decreases in time. Adapted from (Carbon

Operational carbon can be minimized using passive design techniques (Figure 1.3). However, to reduce embodied carbon, it is essential to consider factors like materials, sourcing, and overall façade system design (Eckersley O’Callaghan, 2021). In this context, the circular economy, especially Design for Disassembly (DfD) strategies, is becoming increasingly relevant. DfD enhances sustainability by optimizing material and energy cycles, reducing waste, and merging design with maintenance and product reclamation (Overend & Hartwell, 2019).



**Figure 1.3.** Façades Path to Net Zero. Focus on reducing Embodied Carbon in Façade Systems. Adapted from (Eckersley O’Callaghan, 2021)

Hartwell et al. (2021) found that many contemporary façade designs neglect disassembly aspects, impeding the effective reclamation of materials. Durmisevic (2017) notes that the exploration of how initial design choices influence end of life material reclamation is sparse. Thus, creating a method to determine how design decisions affect material reclamation is essential for optimizing design and understanding a façade system's environmental performance.

This study seeks to address the knowledge gap between by introducing a framework that merges existing models with the specific needs of the façade sector. This framework emphasizes evaluating how design influences material reclamation. Subsequent chapters delve into the relationship of the façade industry and stakeholders with the circular economy and analysis of current disassembly assessment methods, highlighting areas of improvement. A proposed framework is then presented and tested using a relevant case study of a aluminium curtain wall stick system. Ultimately, the research presents a disassembly assessment model with potential applications in developing digital tools.





Source: Author



# 2 Research Framework

2.1	Problem Statement	13
2.2	Research Questions	14
2.3	Research Objectives	14
2.4	Research Methodology	15
2.5	Limitations	17
2.6	Keywords & Definitions	17

## 2.1 Problem Statement

To reduce the embodied carbon of façade systems, Design for Disassembly (DfD) has emerged as a relevant topic in the façade industry. However, a notable gap exists between stakeholder awareness and comprehensive assessment methods that can quantify the influence of DfD criteria during the early design stages and their impact on material reclamation potential at the end of life. Stakeholders within the façade industry have identified a critical deficiency in quantitatively assessing the potential for material reclamation based on design choices. Currently, it remains unclear whether façade designs prioritize ease of disassembly for material reclamation. Developing a disassembly assessment framework is essential to plan and execute suitable material reclamation strategies for façade systems and allow to predict end of life scenarios.

## 2.2 Research Questions

The literature gap identified through the conducted research has guided to the following research question:

### Main Research Question

1. How can a disassembly assessment framework be developed to specifically evaluate the influence of design for disassembly on material reclamation at the end of life of an aluminium curtain wall façade system?

### Sub-Research Question

2. What are the challenges and opportunities associated with implementing circular design principles in façade materials and products within the façade supply chain?
3. How can the impact of different design choices based on DfD be quantitatively assessed? What are the available metrics?
4. To what extent can a framework that incorporates DfD provide a comprehensive view of how various parameters affect façade systems' end of life reclamation?
5. How can the data required to conduct disassembly assessment be structured in a comprehensive way and lead to implementation of digital tools?
6. How can the disassembly assessment framework be extended to inform the reclamation potential of *existing* curtain wall façade stick systems?

## 2.3 Research Objectives

To address these challenges, the primary goal of the thesis is to support decision-making regarding the façade's material reclamation potential based on early stage Design for Disassembly criteria.

7. Identify the Design for Disassembly criteria and assessment criteria.
8. Develop a framework that integrates Design for Disassembly (DfD) principles into the early design stages of façade systems.
9. Quantitatively assess the impact of different design choices on the recoverability of materials in façade systems at the end of their life.

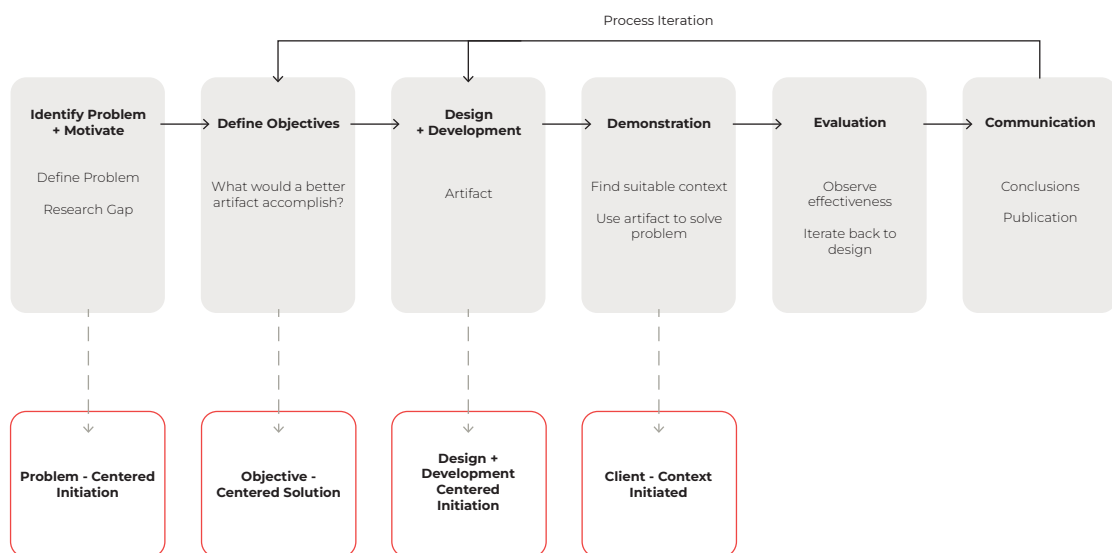


## 2.4 Research Methodology

In order to create the method, a range of techniques were utilized. This includes the extensive review of relevant literature, design and development, demonstration of the method and validation of results by testing on relevant use cases. The overall approach is based on the principles of Design Science Research, as the ultimate goal was to produce a tangible outcome, specifically a method.

Design Science Research is an approach that aims to improve technology and science by creating innovative solutions to problems (Brocke et al., 2020).

This method provides a six-step framework that helps researchers create a rigorous approach to arrive at the intended outcome as shown in Figure 2.1.



**Figure 2.1.** Design Science Research Methodology Process Model. Adapted from (Brocke et al., 2020).

Based on the Design Science Research approach, a research plan was developed for this research paper, as illustrated in Figure 2.2. The first step in the research plan was to identify the problem and the involved stakeholders. This was followed by a thorough review of the relevant literature to gain a deep understanding of the existing gap and potential solutions. The next step involved developing an initial framework. After this, the framework is evaluated on different use cases to ensure its effectiveness and usability. Finally, this research paper presents the results of the evaluation, along with recommendations for future improvement.

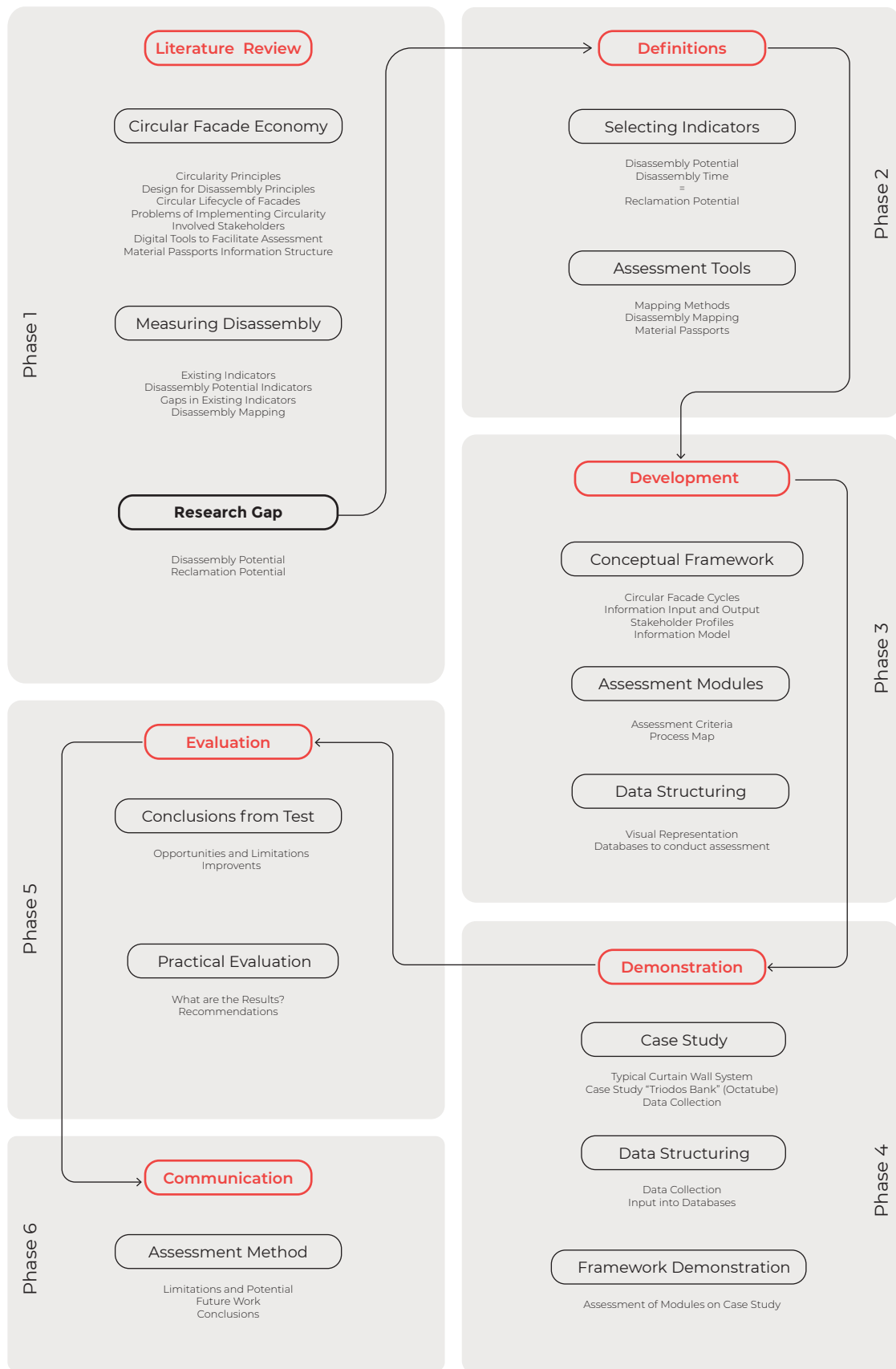


Figure 2.2. Research Outline Diagram. (Author).

## 2.5 Limitations

1. The concept of circularity in the built environment as of the timeline of this research, is still being developed. There is a lack of verifiable data on the subject, since it is a relatively new topic, making validation difficult.
2. Circularity indicators are often subject to qualitative evaluation, which introduces a risk of biased results, especially from those already involved in circularity initiatives.
3. Façades vary widely in typology, materials, component clustering, functionality, and other attributes. The framework is specifically designed for façades based on typical materials (e.g. glass, extruded aluminium) and typical connection types (e.g. silicone adhesives, bolts, screws, etc). Consequently, the research conducted in this thesis can serve as a foundation for future analyses of other systems.
4. Economic factors like CO2 taxes and material costs have not been included in the current assessment, meaning the financial implications and viability of the suggested processes and solutions were not evaluated. Nevertheless, subsequent research could consider these aspects, analyzing market prices of materials, economic value gain and loss, and incorporating labor costs into the evaluation.

## 2.6 Abbreviations & Definitions

- EoL** (End of Life): Refers to the inability of a system to perform its intended function or can not adapt to new needs.
- DfD** (Design for Disassembly)
- DP** (Disassembly Potential)
- EPD** (Environmental Product Declaration)
- BoM** (Bill of Materials)
- RP** (Reclamation Potential): Refers to the potential of a product to be reused, recycled, or recovered at the end of its lifecycle. This potential is judged by its design, materials and ease of disassembly.

## 3 Circular Façade Economy

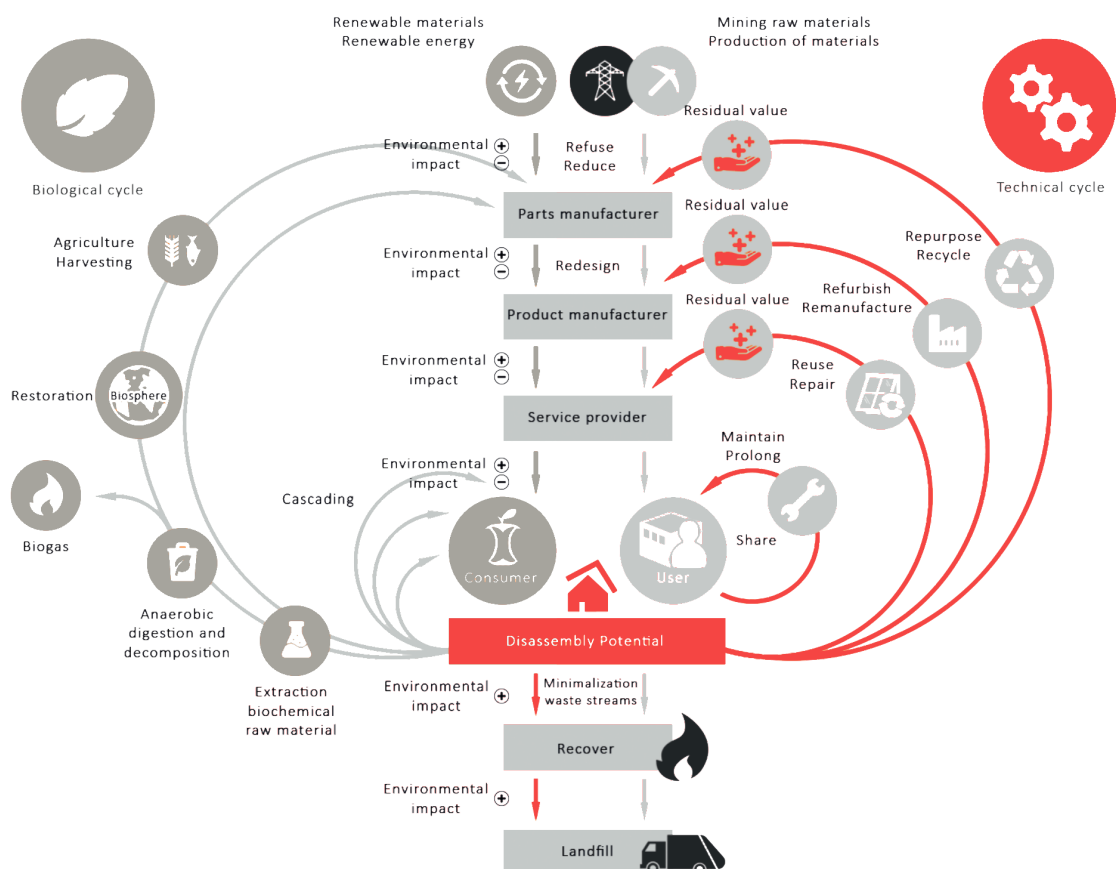
3.1	Circular Economy in the Built Environment	19
3.2	Focus on Design for Disassembly	24
3.3	Typical End of Life of Curtain Wall Façade Systems	27
3.4	Material Flows	30
3.5	Circular Lifecycle of Building Façades	36
3.6	Digital Tools in the Circular Façade Economy	40
3.7	Conclusions	45



### 3.1 Circular Economy in the Built Environment

The global economy predominantly operates on a linear 'take-make-waste' model, contributing to waste and carbon emissions (Vliet, 2018). This problem has spurred a shift towards a circular economy, a system designed to close material and energy cycles by focusing on reduction, reuse, recycling, and reclamation (Kirchherr et al., 2017; Radivojević et al., 2018; Allwood, 2012; Lambert et al., 2004).

The circular economy views end-of-life products not as waste but as potential resources to be repurposed (Radivojević et al., 2018; Allwood, 2012). In the technical cycle, materials and products are reintroduced into different material retentions cycles, thus reducing landfill or incineration and promoting material reuse. Figure 3.1. visualizes the circular economy framework. To enable these cycles, materials must be reclaimed, a challenging task since buildings are structures with various interconnected products and materials. The potential to dismantle these connections while ensuring the components remain functional and suitable for high-quality reuse defines the level of disassembly potential (Van Vliet, 2021).



**Figure 3.1.** The technical cycle of the butterfly diagram. Adapted from (DGBC, 2021).

## Circularity of Construction and Demolition Waste

The European Environment Agency (2020) outlined opportunities to optimize the use of construction and demolition waste, as shown in Figure 3.2. They emphasized the need for Design for Disassembly (DfD) to enhance material recycling and reuse. Additionally, they underscored the benefits of material passports in evaluating building components, materials, and streamlining data gathering.

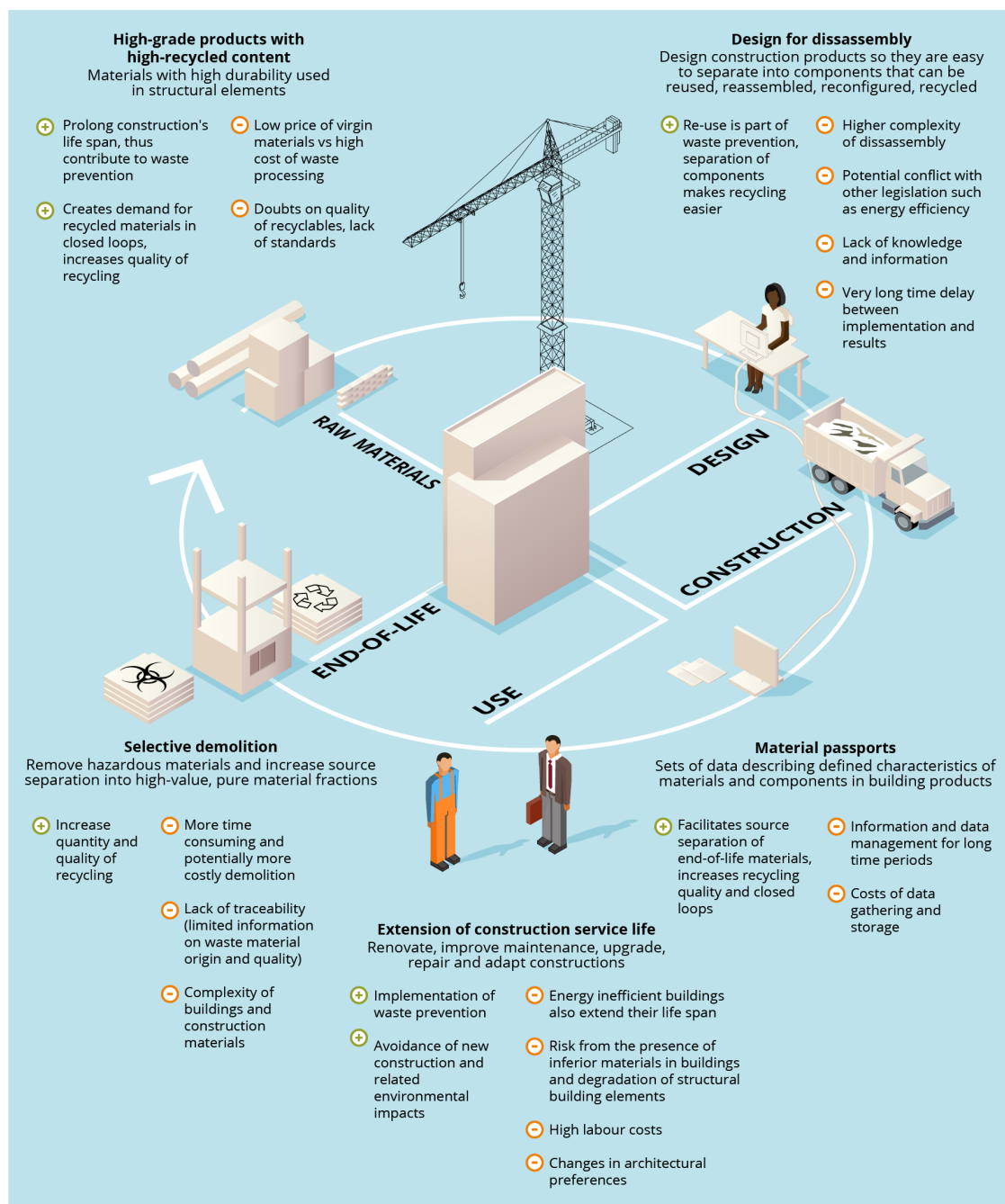
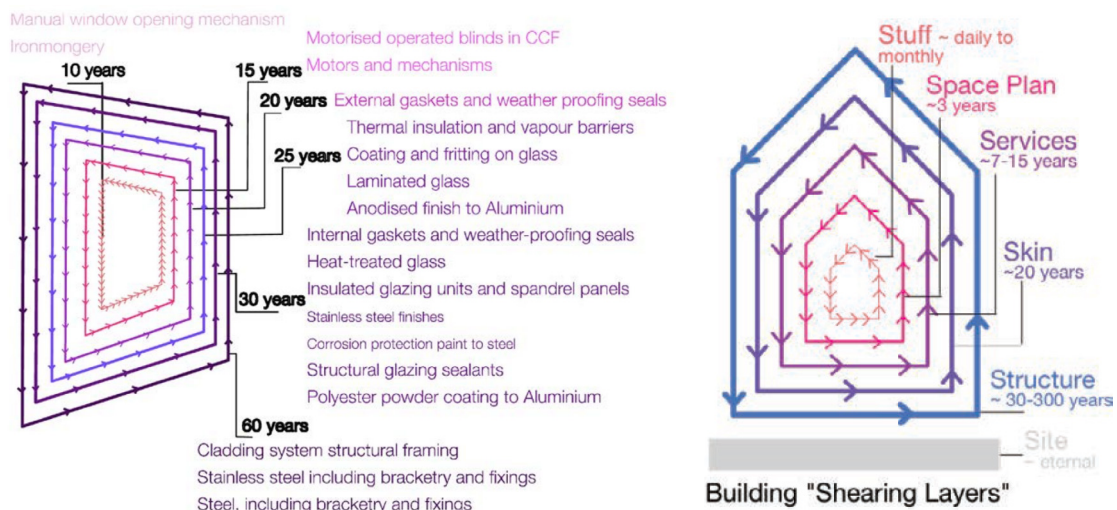


Figure 3.2. Improving Circularity in Construction. (European Environment Agency, 2020)

### The Theory of Levels

The concept of a Circular Built Environment is multidimensional, encompassing everything from materials and components to entire buildings and cities. Within this structure, circular design integrates technology, resource and energy flows, society and stakeholders, economy, and overarching management strategies (Ellen McArthur Foundation, 2013). Crucially, a Circular Built Environment also accounts for the often-overlooked dimension of time, which is not typically considered in a linear economy (Overend & Hartwell, 2019).

Brand (1995) introduced the idea of shearing layers of change, which has informed various research studies on end of life scenarios for buildings and their components (Figure 3.3.). Each layer in this model has a distinct life cycle, which can guide design decisions regarding their longevity and end of life options. The structure of a building typically has a longer life span than its contents, resulting in specific components needing more frequent replacement throughout the building's life cycle (Brand, 1995). The complex assembly, aesthetics, and environmental wear on modern façade systems often lead to shorter lifespans for some components compared to the building's structural elements. Evolving user needs and advancements in construction can result in the façade reaching its end of life sooner than expected, potentially every 20 years or so (Hartwell & Overend, 2019). Special attention needs to be paid to components within this system, and should be designed for easy removal and disassembly to keep materials in closed loops.

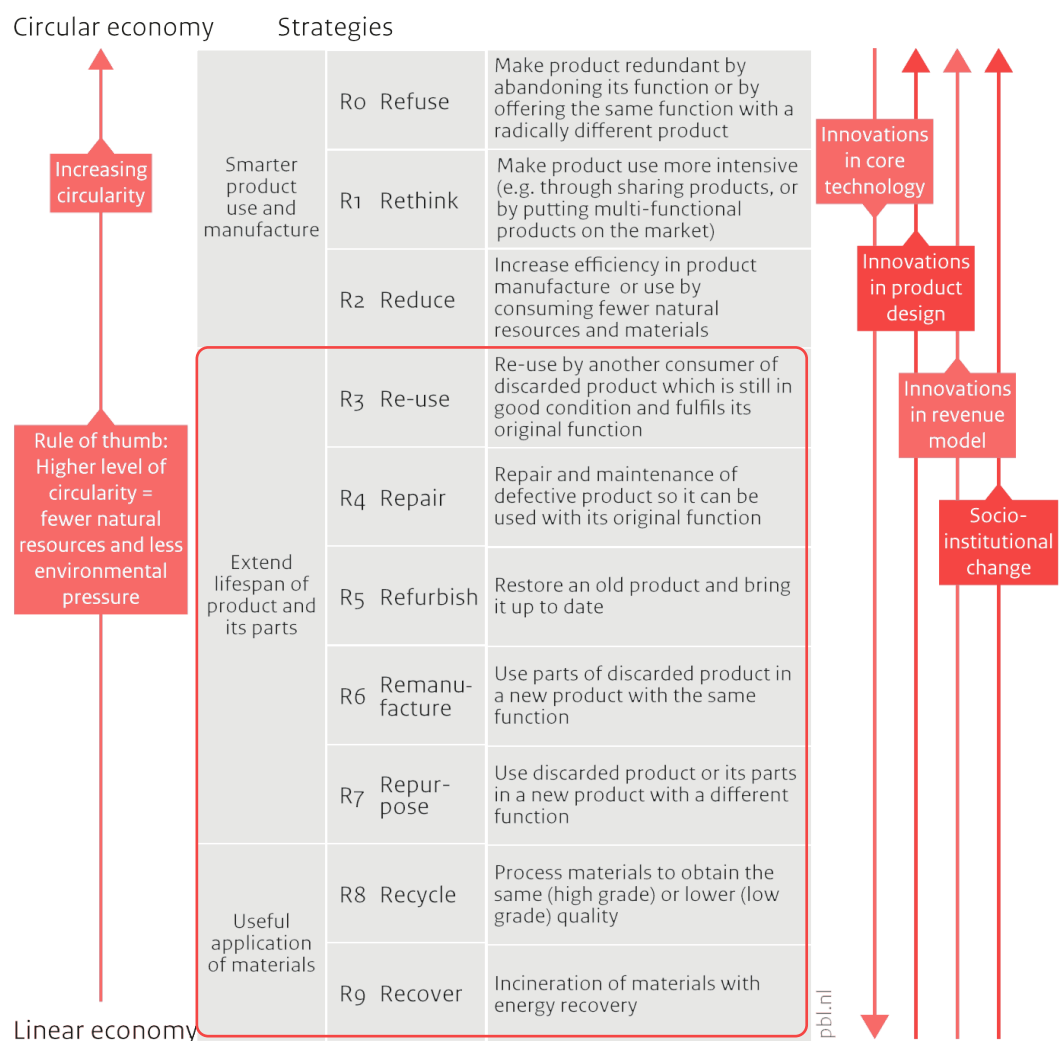


**Figure 3.3.** Lifespan of elements within a typical window system (left). Building Shearing Layers (right). (Hartwell & Overend, 2019)

## Hierarchy of Product and Material Reclamation

When assessing environmental impacts, the reclamation method has to be considered (Overend & Hartwell, 2019). Potting et al. (2016) outline a value generation hierarchy in Figure 3.4., with Design for Disassembly (DfD) promoting the highest reclamation levels, especially through material and component reuse (Durmisevic, 2006).

Potting et al. (2016) highlight that prioritizing strategies remanufacturing, sharing, and lifetime extension improves circularity, followed by recycling materials, while incineration is less favorable. This approach aims reduce the need for new resources. In the context of this research R3 to R9 are being considered, since already existing designs are also being evaluated.

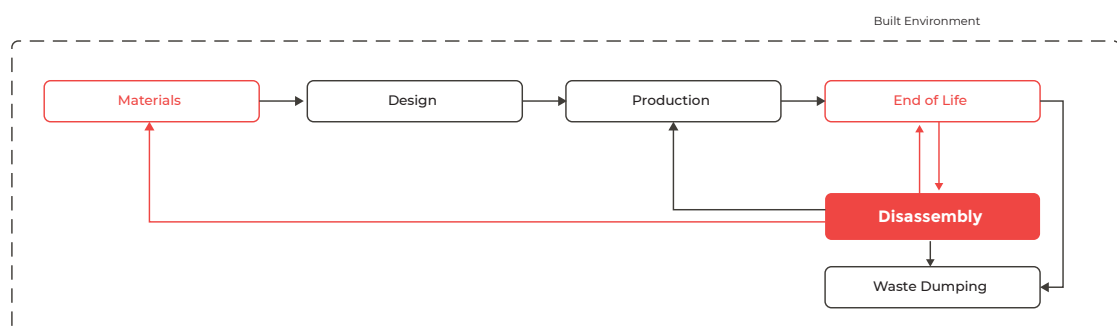


**Figure 3.4.** The 9R framework of the Circular Economy. Adapted (Potting et al., 2016)

## Design for Disassembly for High-value Material Reclamation

To promote a circular building sector, designing components with high reclamation potential is vital, ensuring materials can be continually reused (Reversible Building Design, 2019). Additionally, understanding which materials can be reclaimed is crucial when designing, maintaining, renovating, as well as when buildings reach their end of life (EoL).

Disassembly is pivotal in product reclamation, allowing for the targeted separation of specific components and materials (Güngör, 2006). Products designed for easy disassembly facilitate material reclamation and repurposing (Figure 3.5), thus decreasing the need for new resources and fostering a sustainable, efficient economy (Hutchinson et al., 2016). However, complex façade assemblies often employ many connection types, making disassembly difficult (Overend & Hartwell, 2019).



**Figure 3.5.** Disassembly in Product's Life Cycle. Adapted from (Crowther, 2005)

Durmisevic et al. (2017) identified six barriers to high reclamation of building elements and materials and the implications of Design for Disassembly:

- 1. Lack of data on the technical composition of buildings and element quality.**
- 2. No certification tools for reusable elements.**
- 3. Missing design, disassembly, and decision-making protocols.**
- 4. Absence of reverse logistics and market strategies for reuse.**
- 5. Uncertainty in managing long-term investment risks in reusable structures.**
- 6. Buildings often get demolished due to the absence of supportive decision-making protocols rather than their low disassembly potential.**

Addressing these challenges requires thoroughly understanding building disassembly, element reuse options, and enhancing reuse potential through design. Limited attention has been given to façade systems, especially considering the intricacy of the materials and construction techniques used (Overend &



## 3.2 Focus on Design for Disassembly

Design for Disassembly (DfD) is a crucial strategy for promoting circularity in construction, as recognized in the latest EU taxonomy and defined in ISO standard 20887: 2020 (International Organization for Standardization, 2020). The goal is to design products or building components for easy disassembly, facilitating their reuse, recycling, or diversion from waste. This focus starts at the initial design phase, where over 70% of environmental impact can be addressed (Dams et al., 2021).

While disassembly typically occurs at the end of a product's life cycle, it should be considered from the outset (Marconi et al., 2019). It mainly occurs at component junctions, requiring an in-depth understanding of the connections.

The success of disassembly can result in different end of life scenarios as can be categorized into three distinct methods (Chini & Schultmann, 2002):

1. Nondestructive disassembly: Repair or Reuse
2. Semidestructive disassembly: Remanufacturing
3. Destructive disassembly: Recycling or Disposal

The first approach is reversible and is typically employed when the aim is to repair or reuse the product. The objective is to minimize the time needed for disassembly while ensuring the products are recovered with no damage (Vanegas et al., 2018). In contrast, destructive and semidestructive disassemblies are irreversible processes that may result in different end of life (EoL) outcomes (Rios et al., 2015). For example, a semidestructive method might be chosen when a component needs refurbishing. However, a destructive method can be approached when the focus is on recycling or disposal of a part (Sonnenberg & Sodhi, 2002).

As previously discussed, the Ellen MacArthur Foundation (2013) outlines specific design strategies that correspond to the hierarchy of product reclamation. These strategies fall under the Design for "X" (DfX) umbrella. DfX methodologies focus on refining the product development process to meet distinct goals.

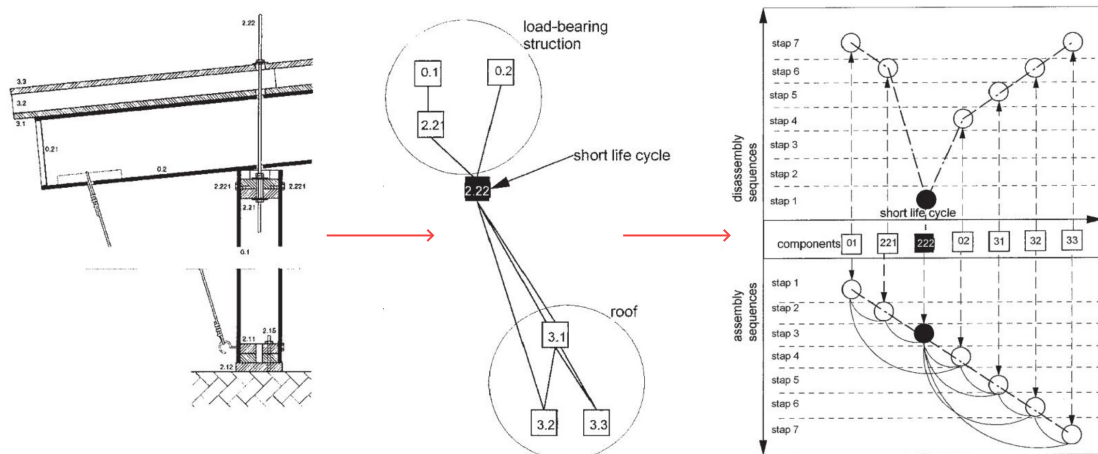
Design for Repair aims to prolong product lifespan by facilitating part replacement, Design for Remanufacturing focuses on refurbishing used products and providing insights for product improvement, and Design for Adaptability ensures products can adapt to changes, thereby enhancing their longevity (Formentini & Ramanujan, 2023). Lastly, Design for Disassembly (DfD) promotes the easy separation and reintegration of products or components, directing materials to their appropriate recycling or disposal cycles (Rios et al., 2015). While assembly and disassembly are contrasting processes, DfD is the primary strategy for maximizing product part reuse (Durmisevic, 2006).

## Design Principles

Durmisevic (2017) offers a systematic DfD approach that emphasizes the design of structures or products for easy disassembly. This approach prioritizes adaptability, component replaceability, and reuse. Durmisevic (2006) assesses a structure's adaptability and component reusability across three main areas:

1. **Functional Decomposition:** This considers the functions integrated into a building component and is shaped by material choice and their adaptability to change.
2. **Technical Decomposition:** Assesses the clarity of a component's hierarchical structure, ensuring precise labeling of its functions and elements.
3. **Physical Decomposition:** Evaluates the shapes and interfaces of components and their impact on disassembly. It also considers the assembly sequence to understand the complexity of the disassembly process.

Figure 3.6. illustrates models that were designed to illustrate the factors contributing to a building's adaptability (Durmisevic 2006). They can also depict the sequences for assembly and disassembly and the interconnections among different components.



**Figure 3.6.** Systematization of Façades Disassembly. Adapted from (Durmisevic, 2006)

A proposed method for automating the generation of these models involves creating relational diagrams from Building Information Models (BIM) through the application of graph theories and network analysis, as suggested by Denis, Temmerman, and Rammer in (2017). However, currently no known software is designed for such tasks.

## Design for Disassembly Influence on Material Retention Loops

Section 3.1. discussed the hierarchy of product reclamation and value retention options outlined by Potting et al. (2016), encompassing: maintenance, repair, remanufacture, reuse, recycle, downcycle, incineration, and landfill. These are commonly known as the 9R Strategies or retention cycles (Overvest, 2023).

These retention cycles can be separated in the following way (Reike et al., 2018):

### Short loops with the highest value retention

Refuse - Reduce - Resell - Repair

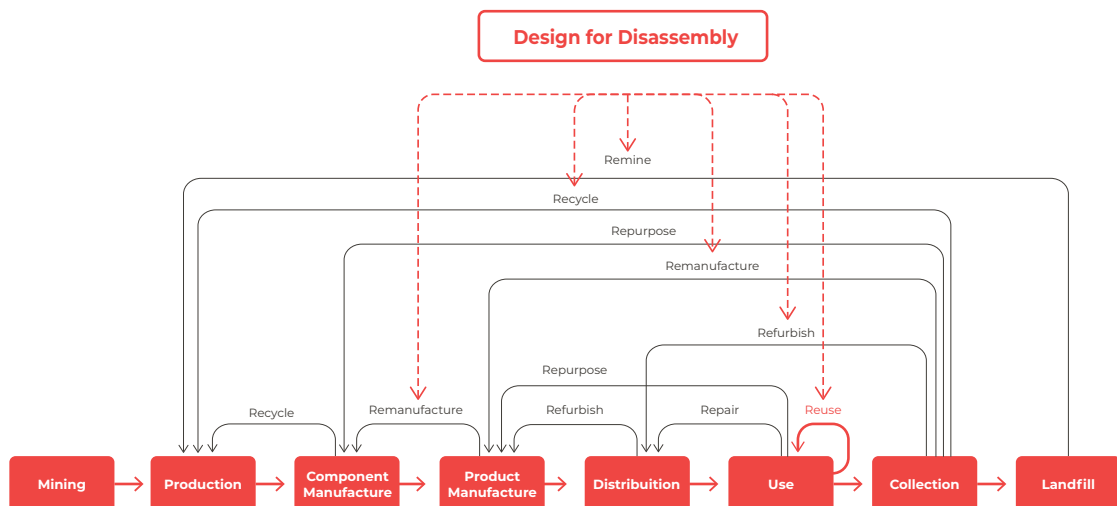
### Medium loops with reduced value retention

Refurbish - Remanufacture - Repurpose

### Long loops with the least value retention

Recycle - Recover - Remine

When integrating the previously mentioned retention loops into a linear product lifecycle and incorporating the different design strategies, the pivotal role of Design for Disassembly becomes evident in the visual representation of Figure 3.7.

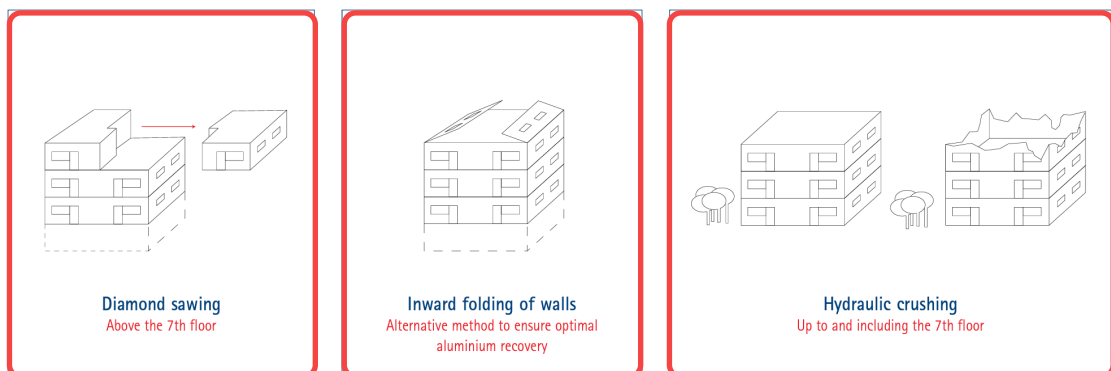


**Figure 3.7.** Design for Disassembly effect on retention loops. (Author)

### 3.3 Typical End of Life of Curtain Wall Façade Systems

Disassembling contemporary façade systems is not the usual practice during end of life scenarios; demolition is the more common approach (Hartwell et al., 2021). To understand the standard procedures and anticipate potential challenges during disassembly, it is valuable to examine the conventional practices.

Demolition methods can be categorized into four groups: manual (using small equipment and hand tools), mechanical (using large machinery from the outside of the building), wrecking ball (using a crane), and implosion (using explosives). Wrecking ball and implosion were popular between 1970-1985 but declined due to environmental concerns (Hendriks & Janssen, 2001). Now, the focus is on manual and mechanical methods to enhance waste recovery. Research by the European Aluminium Association (2004) highlights four primary methods for curtain wall demolitions (Figure 3.8): Hydraulic crushing, diamond sawing, inward folding of walls, and cutting and lifting.



**Figure 3.8.** Illustration of demolition methods (European Aluminium Association [EAA], 2004).

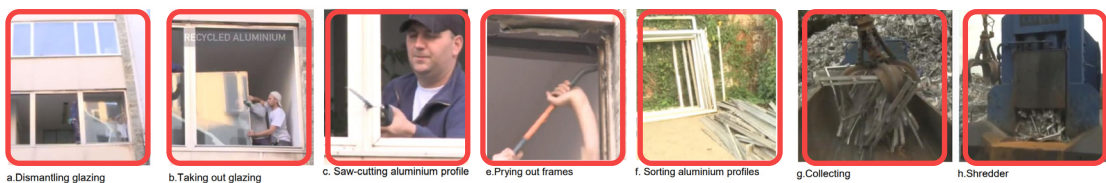
Kim (2013) offers a comprehensive overview of the typical steps involved in the end of life process for curtain walls:

#### Demolition

Hazardous materials are disassembled. After this demolition occurs which usually involves hydraulic crushing, starting from the top floor and working downwards, with a maximum height of approx. 70 m. After this materials are processed and separated. Additionally, production support can be part of the process where precautionary measures are installed such as protecting the surroundings, and pre-soaking the structure to minimize dust. Damage to components is expected.

## Selective Demolition

The first step is disassembly, where depending on the connection types, it is performed to some extent. Curtain wall systems with permanent connections such as adhesive are likely to be demolished. Usually, pressure plates are unscrewed, to remove the glazing. In the demolition phase, the façade is manually demolished using hand-held tools and small machinery. Manual demolition tools include pry bars, saws, hydraulic scissors and chain saws. Processing of the aluminum profiles occurs at the end, where profiles are collected, sorted on-site, and separated from other materials during cutting. They are then sent for further processing, while the remaining materials are considered waste. Erecting exterior workstations and utilizing cranes to support the glazing weight are necessary steps.



**Figure 3.9.** Selective demolition processes for windows (European Aluminium Association [EAA], 2004).

## Disassembly

Before disassembly, there is a thorough inspection and identification of components and materials to facilitate efficient sorting. Considering the available market for materials is also essential. Guy and Ciarimboli (2005) deconstruction guide offers a set of guidelines regarding the handling of disassembled materials. Adapting it for curtain wall systems, the following principle is emphasized:

1. Personnel on-site should be aware of the designated locations for reusable, recyclable, and non-useful materials.
2. Identifying and organizing particular strategies and procedures (including equipment, labor, and sub-contracts) for the removal of materials from the site.
3. Selling materials in advance can minimize the uncertainties linked with disassembly and streamline the process, transportation, and storage of materials.
4. Utilizing reclaimed structural components requires adherence to regulations.
5. Evaluating all materials and potential markets for these.

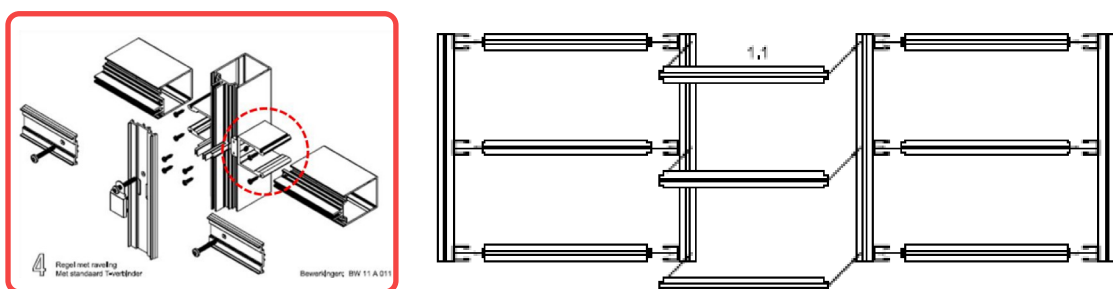


In the process of disassembly, connections are carefully undone without damaging components, following the reverse order of assembly. The type of connection dictates the required disassembly tools and tasks (Figure 3.10). Productivity is often influenced by the ease of disconnecting (De Fazio et al., 2021). While disassembly time can vary by the laborer's experience, adhesive connections generally take the most time (Escaleira et al., 2013). Complex and lengthy connections might result in demolition over disassembly.

Connection Type	Disassembly Task
Mate	Remove
Lock	Move
Bundler	Shear Cut
Spring	Deform or Pull
Screw	Unscrew or Drill
Lock Washer	Deofmr or Pull
Cotter Pin	Pull
Snap Fit	Deform or Pry Out
Press Fit	Pull or Pry Out
Shring Fit	Pull
Rivet	Pry Out or Drill
Fold	Deform
Glue	Peel or Break

**Figure 3.10.** Connection and consequent disassembly tasks. Adapted from (Gungor & Gupta, 1998).

Some connections, like shear blocks (Figure 3.11) only permit for transoms to be connected or disconnected to mullions in one direction, rendering the interlocking component unreachable post-installation (Figure 3.11). If not properly handled, unawareness from the workers, might result in elements being cut out.



**Figure 3.11.** (left) Shear block in typical curtain wall stick system. (right) Interlocking component is not reachable once installation is completed. Adapted from (Kim, 2013).

Safety protocols are applied during the disassembly process. To maintain material quality, small fixtures temporarily secure glazing panels, and aluminum plates are used after detaching pressure plates to prevent glazing units from falling.

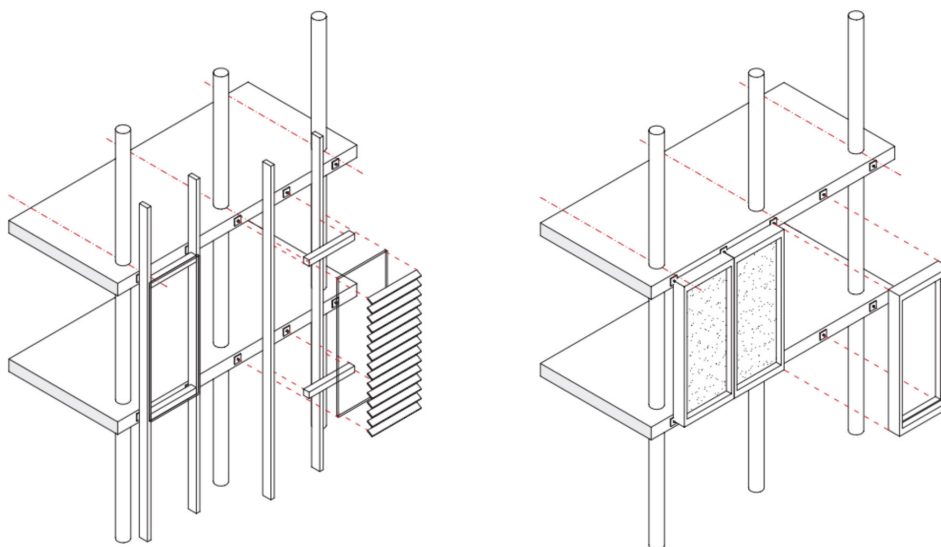
### 3.4 Material Flows

Materials from building structures are transported for processing, with their treatment varying by type and quality. This study tracks curtain wall system materials, specifically focusing on the predominant glazed type. The system comprises aluminum mullions and transoms, with vision or spandrel glazing units.

1. **Aluminium:** For aluminum profiles, the research emphasizes alloys 6060, 6061, and 6062. These usually have different coatings to ensure longevity or aesthetic.
2. **Glass:** Primary material for curtain walls, with Insulated Glazing Units (IGUs) being popular for their insulation properties. IGUs typically consist of two glass layers, insulated with gas, and sealed with an adhesive and an aluminium spacer in between.

#### Curtain Wall Systems

As illustrated in Figure 3.12, there are traditionally two main categories for curtain wall systems: The stick system and the unitised system. This research focuses on the stick systems concerning the construction method. While unitized systems offer benefits like high production quality and quick assembly, their use is often restricted to specific applications, such as highrise buildings. This is due to their complexity, higher cost, and the need for meticulous planning and precision when installing on a building's shell due to limited permissible tolerances (Knaack, 2007). These drawbacks make stick systems more prevalent in the curtain wall market.



**Figure 3.12.** (left) A stick system is installed on site with standard components. (right) A unitized system is constructed as a series of factory-assembled components. (Meijs & Knaack, 2009)

## Stick Systems

Stick systems have three primary applications: (1) Standard Continuous Glazing, (2) Semi-Structural Glazing, and (3) Structural Glazing, as depicted in Figure 3.13. Despite their external differences, all curtain wall system applications follow a standard design. While the design can vary based on manufacturers, the fundamental principle remains consistent. As identified by Haldimann et al. (2007), three main functional components are present. (a) Mullions, handle wind pressure on the façade, (b) Fixation, which connects layers for insulation, and (c) Cover caps, serving a purely aesthetic purpose. While mullion dimensions may change based on structural calculations, and cover caps might be altered or removed for aesthetic reasons, the fixation remains consistent throughout. Additionally, component modularization is crucial for systematic reuse or upgrades, given that future system developments will probably use current components.



**Figure 3.13.** Three main applications of curtain wall system: (1) Standard continuous glazing, (2) Semi-structural glazing and (3) Structural glazing. (Kim, 2013)

## Material Composition

The primary features of standard curtain wall systems, as detailed in the previous paragraph, include a frame and an insulated glazing unit (IGU), as depicted in Figure 3.13. The frame is comprised of elements such as mullion, transom, pressure plate, cover cap, gasket, thermal break, bolts, shear block, and other components like structural reinforcement and fire resistance. Typically, the IGU features two layers of glass with a gas-filled space between them.

The glass makes up around 80% of the IGU's total weight, as derived from a study by Lehmann and Empa (2006). They noted that the edge of a double-glazed IGU accounts for 20% of its total weight. It's recommended to separate this edge from the main 80% of the glass for distinct treatment processes. Typically, the spacer is made of combustible materials, primarily plastics, but also aluminium.

## Material Separation

Materials from end of life (EoL) curtain wall systems should be separated either on-site or off-site (Kim, 2013). If it is cost-effective, separation happens on-site, especially when materials can be salvaged and sold individually. Waste is divided into four groups, modified to suit curtain wall systems:

1. **Reuse:** High-quality IGU and aluminium profiles. Components are repurposed for their original intent, potentially undergoing repair or upgrading, but older curtain wall elements often do not meet current standards, leading to their export to less regulated countries or necessitating further processing (The European Aluminium Association, 2004).
2. **Recycling:** Materials from demolished curtain walls, including glass, aluminium, and sorted plastic, undergo various recycling and recovery processes. The European Aluminium Association (2004) differentiates between new aluminium scrap, derived from production surplus, and old aluminium scrap, which is post-consumer material needing extra processing. Given the scarcity of high-quality new scrap, recycled aluminium is not exploited in new curtain wall profiles. Insulated glazing units (IGUs) must be separated for quality glass recycling. Challenges, as highlighted by Hartwell et al. (2022), include obtaining uncontaminated flat glass cullet efficiently. Consequently, glass from end of life curtain wall systems often finds use in alternative products, like road aggregate.
3. **Incineration:** Mixed plastics and glazing edges with combustible spacers. Some polymers are recyclable, though none fit curtain wall systems. Incineration of non-recyclable plastics may produce more CO<sub>2</sub> than landfilling, but efficient energy recovery can make incineration environmentally favorable compared to traditional energy sources (Eriksson & Finnveden, 2009).
4. **Landfill:** These, if not separated, devalue other materials. For instance, minor metal scraps contaminate glass or aluminium alloys during recycling. Such materials are dispatched to inert landfills.

While choosing between options can be challenging, reusing waste is the most preferred method, with landfilling as the least favored. If the above solutions are unfeasible, alternative methods should be considered.

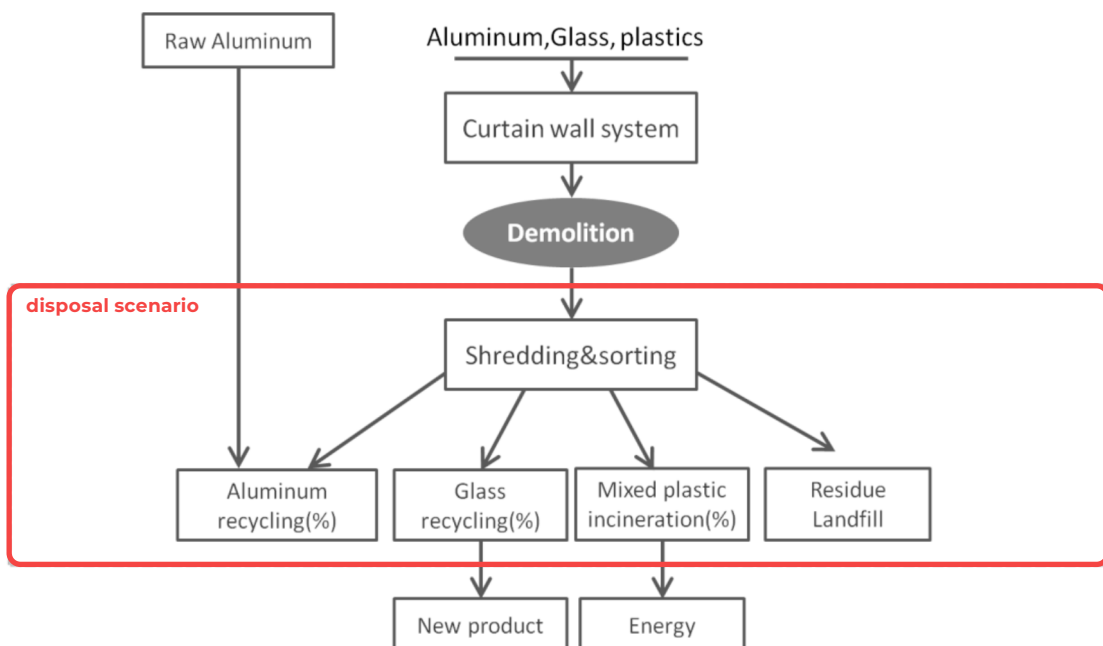
## Material Flows and End of Life Treatments

This section outlines the material flows for three current EoL curtain wall system scenarios: demolition, selective demolition, and disassembly. While demolition efforts aim to maximize waste recovery in line with environmental policies, material loss can occur, reducing separation efficiency. Disassembly typically achieves the best material separation, emphasizing component reuse.

Kim (2013) notes that on-site sorting during demolitions often requires further processing for recycling. Selective demolition separates valuable materials, leaving mixed waste. Disassembly allows direct transport of separated materials, whereas demolition materials typically undergo two transport stages, except for aluminium profiles in selective cases.

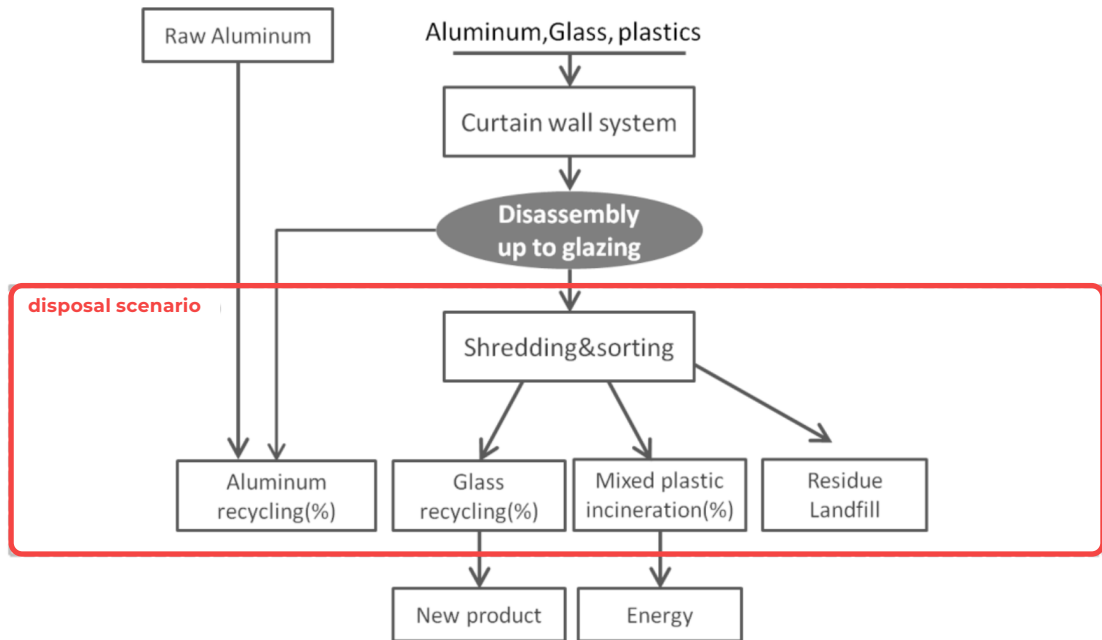
The main characteristics of these scenarios are depicted in figures 3.14, 3.15, and 3.16.

1. **Scenario 01: Demolition:** Materials from dismantled curtain wall systems are sent to a shredding and sorting plant in a combined form. After processing, they're directed to recycling, incineration, or landfill sites. While recycling is the ideal recovery method in this scenario, materials from the demolished curtain wall systems cannot be repurposed into the same product, eliminating a direct link to new curtain wall systems.



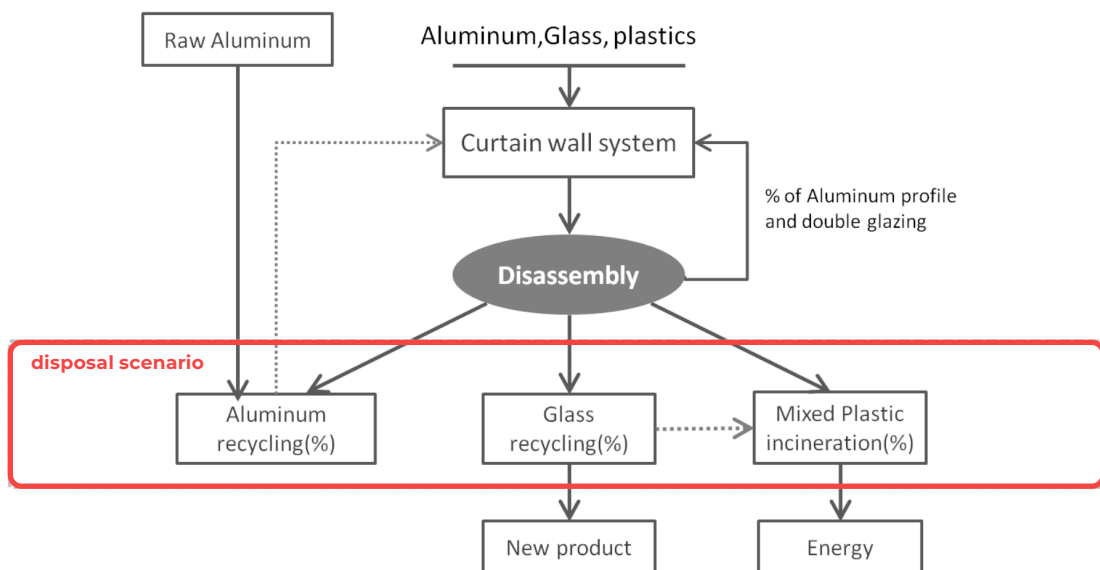
**Figure 3.14.** Material flows of demolition scenario. Adapted from (Kim, 2013)

2. Scenario 02: Selective Dismantle: During disassembly, glazing is removed and aluminium is separated. Glazing, though carefully extracted, joins other waste as it requires shredding. Apart from aluminium, materials are sorted but aren't reused in curtain walls.



**Figure 3.15.** Material flows of selective demolition scenario. Adapted from (Kim, 2013)

3. Scenario 02: Selective Dismantle: Disassembly prioritizes reuse, especially of intact aluminium profiles and double glazing units. Other materials are directly recycled or incinerated, with aluminium reused and glazing edges incinerated.



**Figure 3.16.** Material flows of disassembly scenario. Adapted from (Kim, 2013)



## Barriers to Implementing Disassembly

In the previous section, three EoL scenarios for modern curtain wall systems were detailed, highlighting on-site disassembly activities, material flows and potential material treatments. Kim (2013) identifies the main barriers to implementing disassembly in their research. The barriers include:

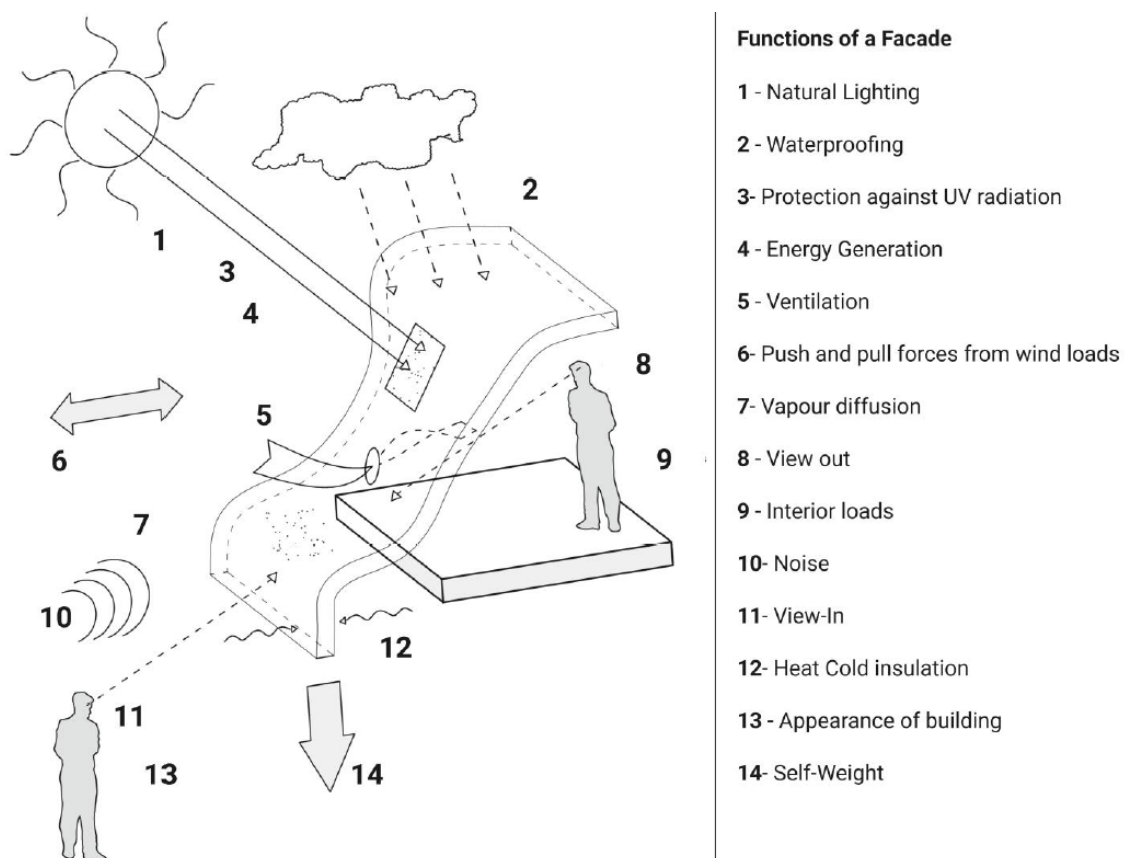
1. Disassembly Sequence Complexity: Disassembly, done in reverse installation order to minimize damage, can fail if workers are unfamiliar with the steps. There's a need for clear disassembly guidelines and future designs should aim to simplify the process.
2. Varying Connection Methods: Certain connections, like interlocking components, can be time-consuming and dictate a specific disassembly sequence. When impractical, these might be cut. Connection types, hence, should be thoughtfully decided during the design phase to ease disassembly.
3. Time and Labor-Intensive Supporting Tasks: Disassembly requires several supporting tasks for safety and accessibility, which can be labor and time-consuming. For instance, special measures might be needed when dealing with glass panes.
4. Lack of a Used Component Market: Economic viability of disassembly can be ensured by selling used components in advance. However, a robust market or advertising network is unknown. Strategies to stimulate this secondary market need exploration.
5. Lack of a System for Tracking Material Information: Without a system to identify product details, there is often a resort to down-cycling due to potential quality risks from contaminants. For instance, old aluminium scraps are not used in new profile manufacturing, even if possible. A tracking system for component history and material characteristics could be beneficial.

Strategies to address these issues are crucial for a practical disassembly approach for curtain wall systems, and will be discussed in the following chapters.

### 3.5 Circular Lifecycle of Building Façades

Different building components have varying lifespans, a concept known as "shearing layers" (Brand, 1994). Façades, for instance, typically last around 20+ years due to factors like weather-related wear and tear, evolving trends, energy regulations, and changing building functions (Hartwell et al., 2021). To enhance façade circularity, Design for Disassembly (DfD) is crucial.

In a circular context, each shearing layer, as per Brand's (1995) concept, should be separable. Modern construction, especially for façades, has embraced prefabrication to achieve this goal. Façades, despite their shorter lifespan, can constitute a significant portion of a building's surface area, especially in tall structures where they may represent up to 40% of the total area. Façades serve various functions and are complex assemblies of materials (Azcarate et al., 2018). Figure 3.17. illustrates the different functions of a façade. The complex structure of building façades can pose considerable difficulties in taking them apart and reclaiming materials like glass from current systems for repurposing or recycling when they reach their end of life. (Hartwell and Overend, 2019)



**Figure 3.17.** Common functions of a façade. (Klein, 2013)

### Forward Logistics

While the formal lifecycle usually begins at the use stage, material selection, a critical factor impacting the façade's lifecycle, can start as early as the initial design phases (Figure 3.18), typically within the first three stages (Klein, 2013). **Choices made during conceptual and technical design can affect up to 80% of the building's environmental impact** (Morini et al., 2019). The level of involvement of façade designers and producers may vary, influencing overall design quality (Konstantinou, et al., 2023).

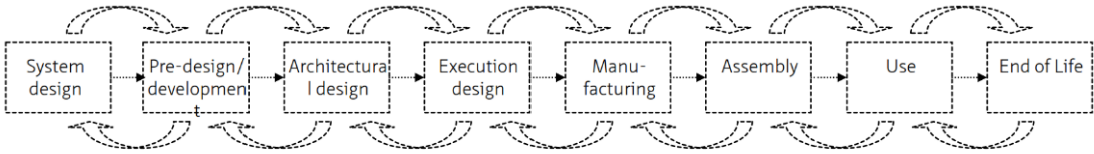


Figure 3.18. Design and construction process for a curtain wall. (Klein, 2013)

### Reverse Logistics

Findings by Schultmann and Sunke (2015) indicate that reverse logistics procedures can be classified into distinct stages, encompassing collection, inspection, sorting, reprocessing, and redistribution, shown in Figure 3.19. In this phase, knowledge about the disassemblability of a façade is crucial.

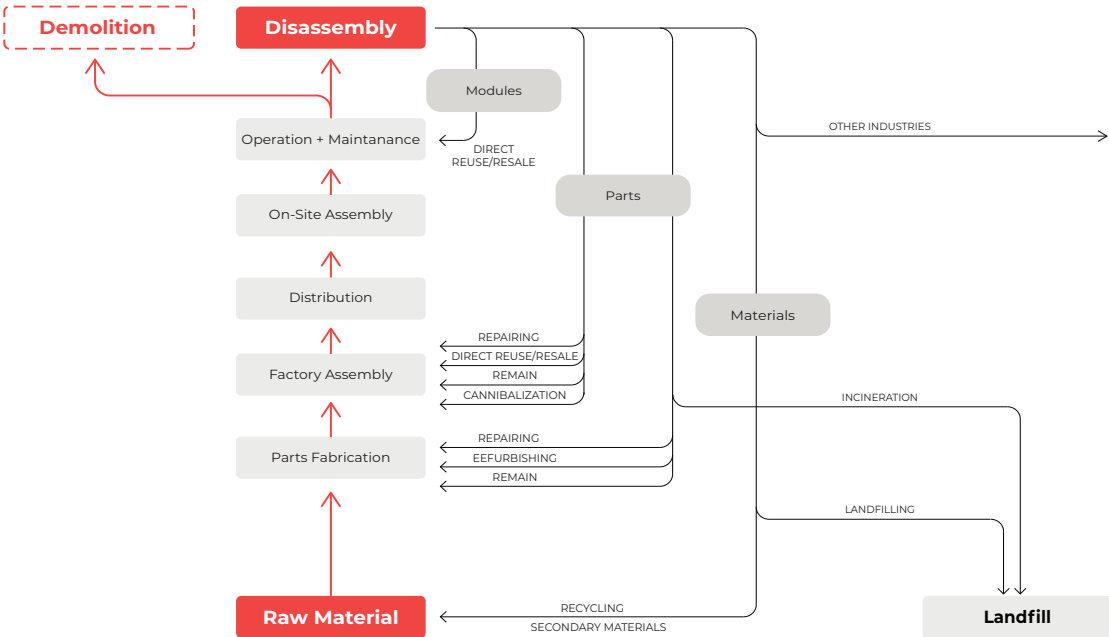
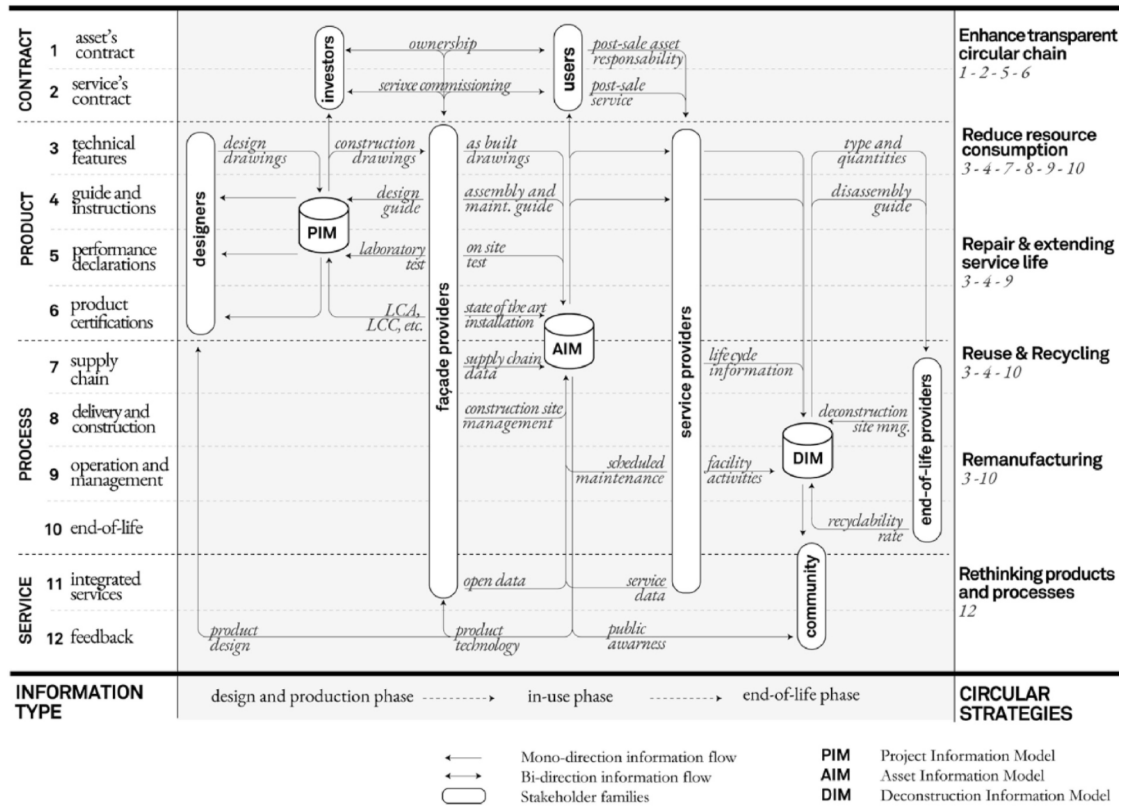


Figure 3.19. Façade reverse logistics based on the circular butterfly diagram. (Leos, 2020)

## Façade Industry Stakeholders and Information Flows

Stakeholder participation in the conventional lifecycle of a façade is illustrated in Figure 3.20, primarily focusing on information flows.



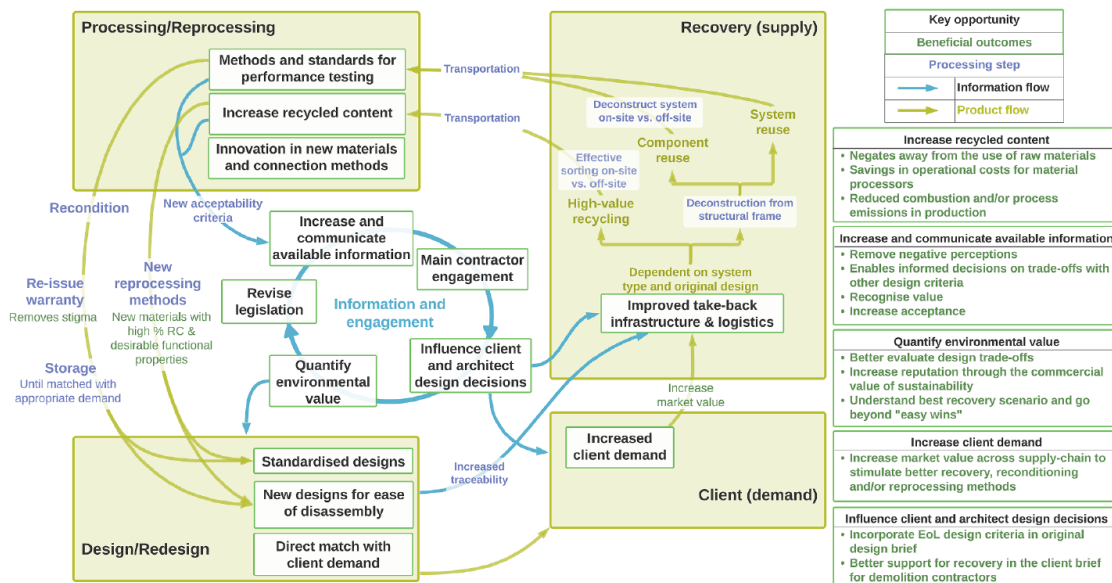
**Figure 3.20.** Façade information flows along the façade life-cycle stages. (Konstantinou et al., 2023).

Various stakeholders participate in different stages, contingent upon the framework. While stakeholder engagement is notably high during the design phase, Klein (2013) observed that there is no great stakeholder involvement at the end of life stage. This reveals a limited understanding of end of life stages which can also inform the design stage. This aligns with the findings by Hartwell et al. (2021), where structured interviews were conducted and underscored that most façade builders lack comprehensive knowledge about the appropriate end of life management of façades.

However, circular business models may necessitate the inclusion of additional stakeholders, particularly in the reverse logistics stage. Traditionally, a logistics manager appointed during the end of life stage oversees the transportation, storage, and distribution of building components. Nonetheless, this process can also encompass other stakeholders, including building demolition experts, reclamation auditors, collectors, and recycling companies (Heinrich & Lang, 2019).

## Shared Opportunities for Stakeholder Collaboration

To successfully implement reuse as a design strategy in façade systems, a reform of the existing supply chain is essential, creating incentives for all stakeholders. Figure 3.21 highlights several strategies that can promote supply chain reform according to previous research conducted by Hartwell et al. (2019):



**Figure 3.21.** Key Opportunities to promote high value reclamation options across the façade supply-chain. (Hartwell et al., 2021).

1. **Improve Take-Back Logistics:** Manufacturers and suppliers should evaluate benefits of different reclamation scenarios, encouraging recovered products.
2. **Increase Available Information:** Manufacturers and suppliers should collaborate closely with designers and contractors to highlight the advantages and trade-offs, encouraging their integration into new designs.
3. **Justify the Environmental Motivation:** More formal environmental assessments specific to multi-component systems are needed to evaluate the benefits and trade-offs of different design options.
4. **Legislation:** New legislation could give more influence to manufacturers, contractors, encouraging the design team to consider reuse.
5. **Recognizing Financial Opportunities:** Experiences of successful circular design should be shared to showcase the potential benefits and business cases for façade reuse and recycling.

## 3.6 Digital Tools in the Circular Façade Economy

Digitalization in construction aims to offer shared information systems for stakeholders, as noted by Konstantinou et al. (2023). Like the broader industry, the façade sector uses stakeholder-specific software and platforms. Konstantinou et al. (2023) divide these tools into three main categories.

1. Building Information Model (BIM): Encompass tools used during the façade design phase. Montali et al. (2019) have identified nine tool categories that support façade design, with BIM being the most suitable for gathering diverse information about materials and components (Honic et al., 2019).
2. Asset Information Model (AIM): AIMS encompass all software and tools used from asset creation to the utilization phase.
3. Deconstruction Information Model (DIM): DIMs are an emerging category of tools designed to oversee the end of life processes of buildings and promote circular management, primarily focused on handling demolition activities, although current disassembly practices are not widely covered.

### Material Passport Data Structure

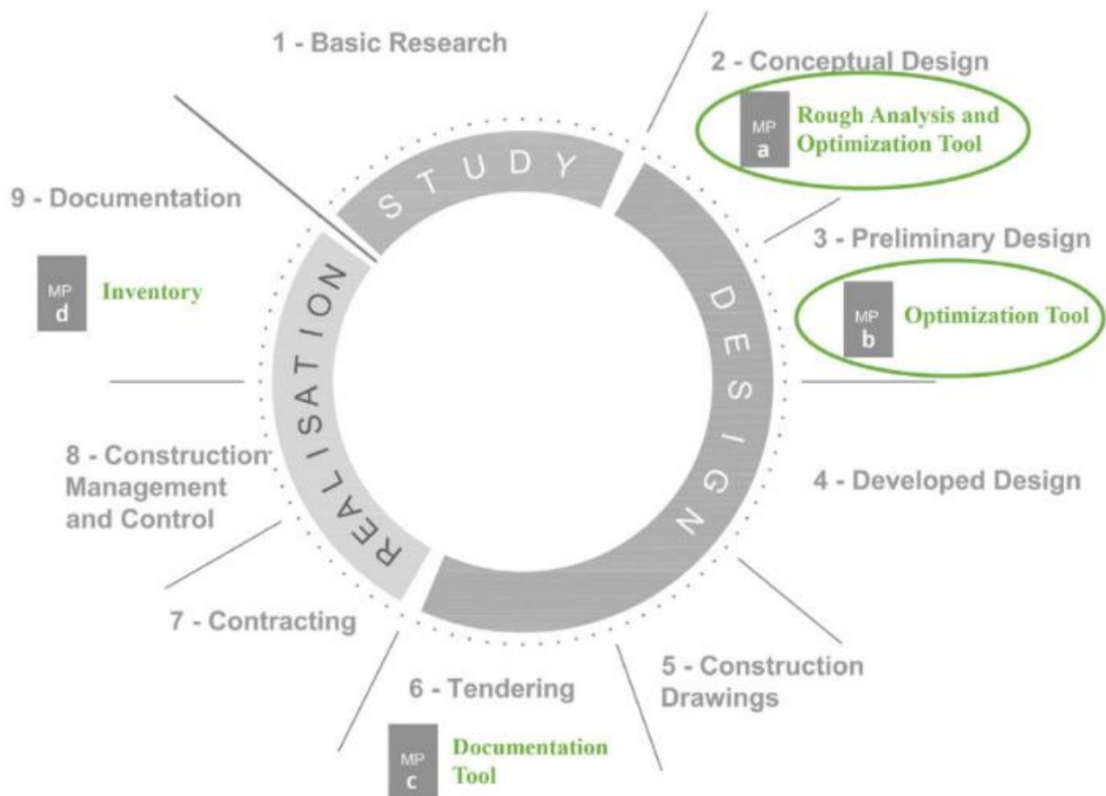
Material Passports encompass digital datasets detailing specific attributes of materials and components within products and systems, emphasizing their value for current use, reclamation, and reuse (Heinrich & Lang, 2019). Existing platforms serve as material passports, but their efficacy might be constrained without standardized content. Heinrich & Lang (2019) detail potential information to include:

4. Identifiers: Unique identification systems utilized for component recognition
5. Manufacturer Information: Technical data on production processes.
6. Monitoring: Installed product information, such as structural fatigue, thermal properties, or any information regarding wear and tear, enabling predictions related to maintenance, performance, or anticipated lifespan.
7. Logistics Information: This type of data is utilized during the material transportation process across different points within the supply chain
8. Certifications: Required material standards and certifications.
9. Material Characteristics: Details on properties like thermal, optical, and structural.
10. Environmental Assessments: Derived from databases or other sources, including LCA ratings and carbon footprints.
11. Design Criteria: Information defining the façade's design, from images to 3D models.



## The Potential of Material Passports

Detailed material specifications during building design and construction significantly impact reusability (Akinade et al., 2019). Material passports have diverse uses throughout a product's lifecycle, from optimization in early design to tracking in the supply chain, maintenance recording during use, and end of life strategy (Heinrich & Lang, 2019). Copeland & Bilec (2020) highlight these uses in building lifecycles, from optimization in early design to supply chain tracking, maintenance records during use, and informing reverse logistics for end of life (Figure 3.22).

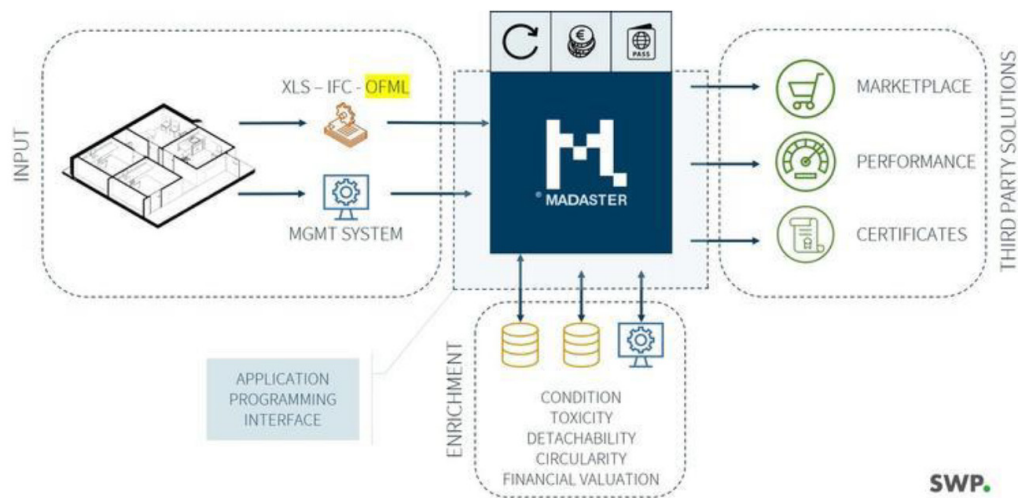


**Figure 3.22.** Material Passports in Different Stages of Building Design (Copeland and Bilec, 2020).

Honic et al. (2019) emphasize that material passports should encompass details regarding recycling potential, disassembly potential, and accessibility. While the recycling potential can be quantified using circularity indicators discussed in the following Chapter 04, accessibility and disassembly potential of materials are typically qualitative (Durmisevic, 2006), involving drawings, diagrams, or visual location indicators within a building.

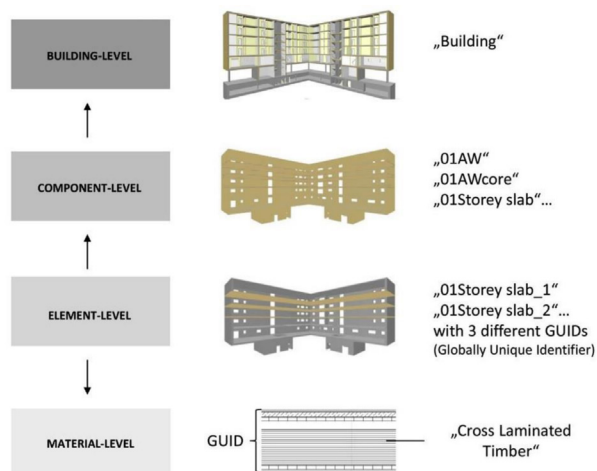
## Existing Material Passports Platforms

Madaster (Figure 3.23), a prominent European material passport platform, uses a BIM model for data input to extract essential material quantities (Madaster Platform, 2023). It employs Brand's Shearing layers concept (Brand, 1995) to provide insights into material quantities within different building layers and assesses circularity using the Material Circularity Indicator (MCI) for both layers and materials within the building (Van Der Molen, 2020).



**Figure 3.23.** Overview of Madaster Material Passport Functionality. (Van Der Molen, 2020).

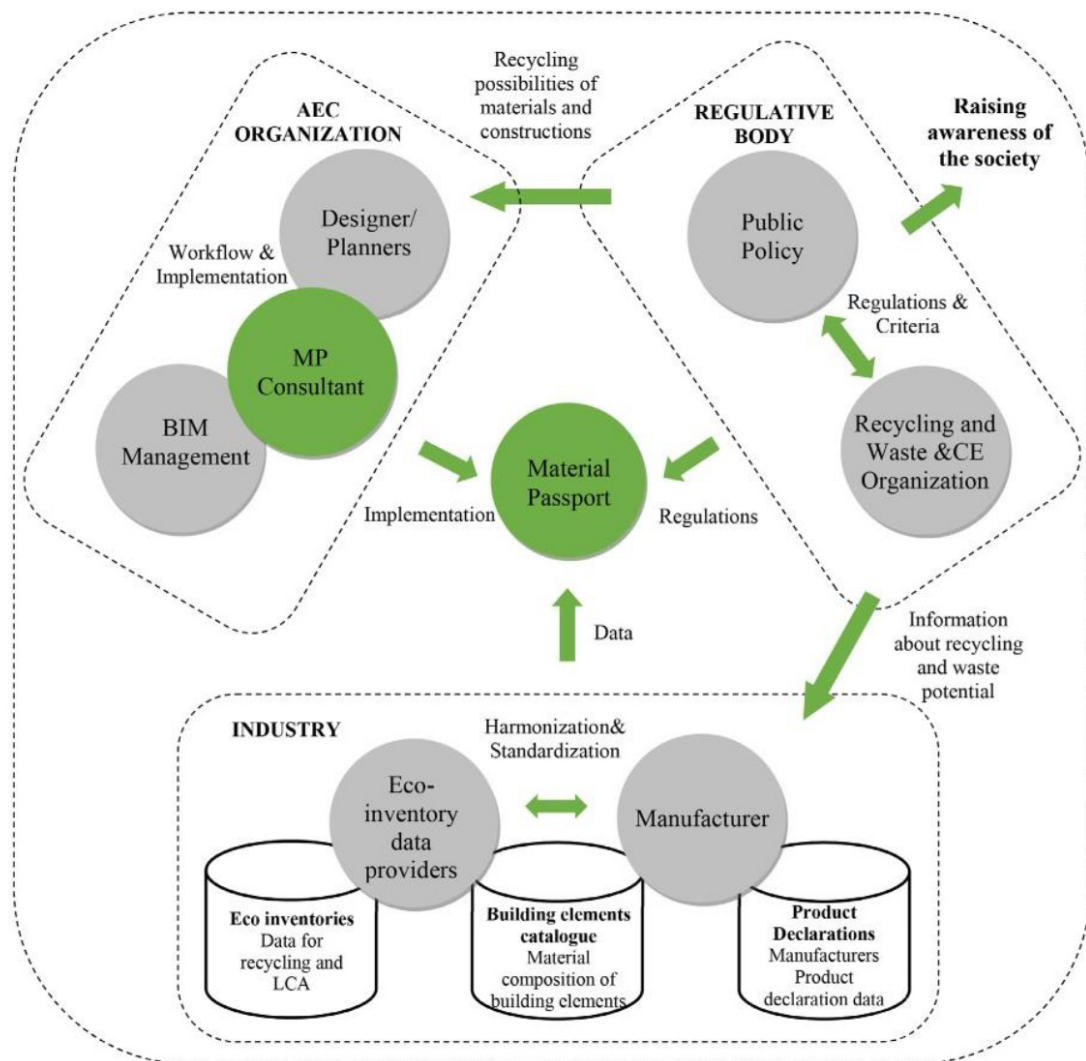
Figure 3.24 illustrates the detail level of information. Buildings can be segmented into various product levels, suggesting a similar categorization for material passports. These passports can be adjusted based on tiers like ingredients, subcomponents, products, and systems (Honit et al., 2019).



**Figure 3.24.** Product levels in BIM-based material passports. (Honit et al., 2019)

### Material Passport Influence on Stakeholders

Copeland and Bilec (2020) introduced a stakeholder management framework for creating a BIM-based material passport, as depicted in Figure 3.25. They introduced a new stakeholder role, the Material Passport (MP) consultant, responsible for data entry and linking databases to the BIM Model. Their workflow involves referencing data from eco inventories and external libraries, emphasizing data harmonization between eco inventories, building element specifications, and product declaration data to facilitate seamless automation. Successful implementation requires robust collaboration between MP consultants, designers, and BIM managers. The result of integrating these systems is raising awareness across stakeholders.



**Figure 3.25.** Material passport consultant as link between the designer and BIM Manager. (Copeland &

## 3.7 Conclusions

This chapter emphasizes the importance and inherent challenges of applying circular principles, especially within building façades. The integration of both forward and reverse logistics processes, involving various stakeholders, is crucial for achieving circular practices. The challenges to the successful adoption of these practices have been highlighted by Hartwell et al., (2021) and Durmisevic et al., (2017). These barriers include issues such as insufficient data on the technical composition of buildings, the unavailability of certification tools for reusable components, and the necessity for clear design, disassembly, and decision-making protocols. A shift from the conventional demolition mindset to sustainable decision-making frameworks is imperative. Furthermore, this chapter sheds light on the limited understanding among stakeholders regarding Design for Disassembly and End of Life considerations in the context of circular construction practices, as noted by Overend & Hartwell, 2019.

The comprehensive literature review brings to light that tools like material passports serve functions beyond merely assembling datasets. As Konstantinou et al., 2023 point out, material passports not only provide technological benefits by allowing data editing, accessibility, and visualization through user-friendly interfaces tailored to stakeholders' unique needs but also impact various stages of a building façade's lifecycle. However, defining the exact scope of a material passport is not straightforward due to its complex nature. Honic et al., (2019) stress that these passports should include specifics about recycling potential, disassembly capability, and accessibility. Durmisevic, (2006) elaborates that while recycling potential is quantifiable, the accessibility and disassembly prospects of materials are usually qualitative in nature, often represented through diagrams or visual indicators in buildings.

Furthermore, digital tools such as Building Information Models (BIMs), Asset Information Models (AIMs), and Deconstruction Information Models (DIMs) are pivotal in promoting information dissemination and aiding decision-making. These tools further the optimization of façade design for disassembly (DfD) and overall enhancements in circularity.

To fully harness the potential of circular practices in building façades, interdisciplinary collaboration, stakeholder involvement, advanced design thinking, and the utilization of digital tools are paramount. Amplifying awareness and spreading knowledge about DfD potential implications for façade end of life scenarios is vital. The subsequent chapter delves into specific strategies and frameworks for incorporating circular principles in building façades and evaluates disassembly to guide end-of-life decisions.



Source: (Grynykha, 2020) .Unsplash.com



# 4 Measuring Disassembly

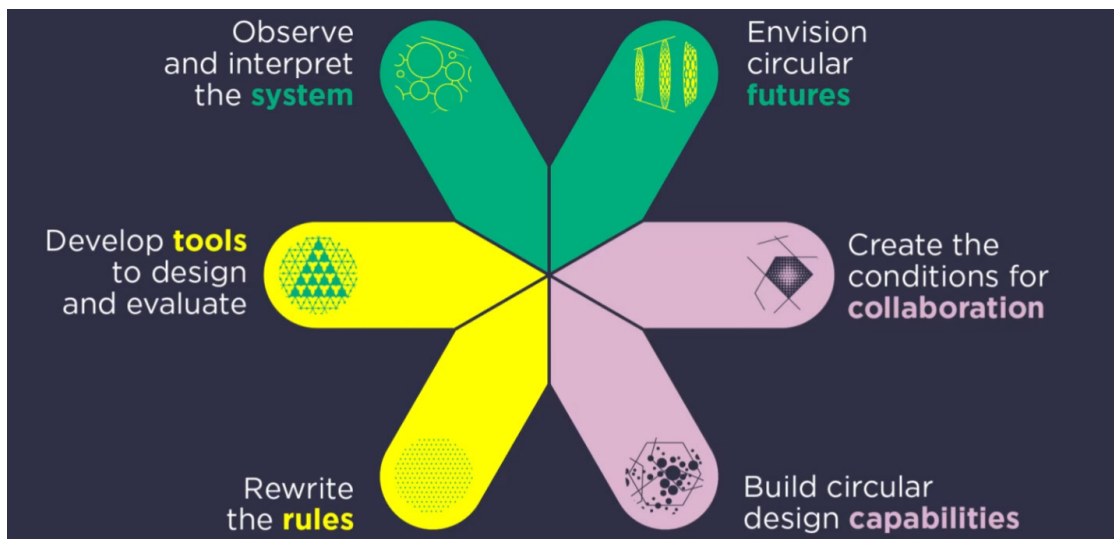
- 4.1 Measuring the Circular Economy 48
- 4.2 Existing Circularity Indicators 49
- 4.3 Disassembly Potential Indicators 51
- 4.4 Disassembly Time Indicators 53
- 4.5 Environmental Indicators 55
- 4.6 Comparing Different Indicators 58
- 4.7 Disassembly Mapping and Relational Diagrams 60
- 4.8 Conclusions 62



## 4.1 Measuring the Circular Economy

The Circular Economy (CE) is a relatively new and complex concept, requiring a clear roadmap for integration into the construction industry. Precise metrics are vital for comprehensive reporting, enabling organizations, including companies, governments, and industry stakeholders, to promote circular practices, especially in procurement.

Design for Disassembly (DfD) plays a pivotal role in extending product service life within a low-carbon circular economy. However, raising awareness of DfD across the façade supply chain and incorporating specialized environmental assessments pose significant challenges (Hartwell et al., 2021). Accurate material reclamation prediction is crucial for designing, maintaining, renovating, or dismantling circular buildings. Based on insights from the Ellen MacArthur Foundation (2015), six primary design leverage points have been identified (Figure 3.26) to facilitate the transition to a circular economy. Among these pillars, the development of new design and evaluation tools is paramount for aligning designs with circular objectives.

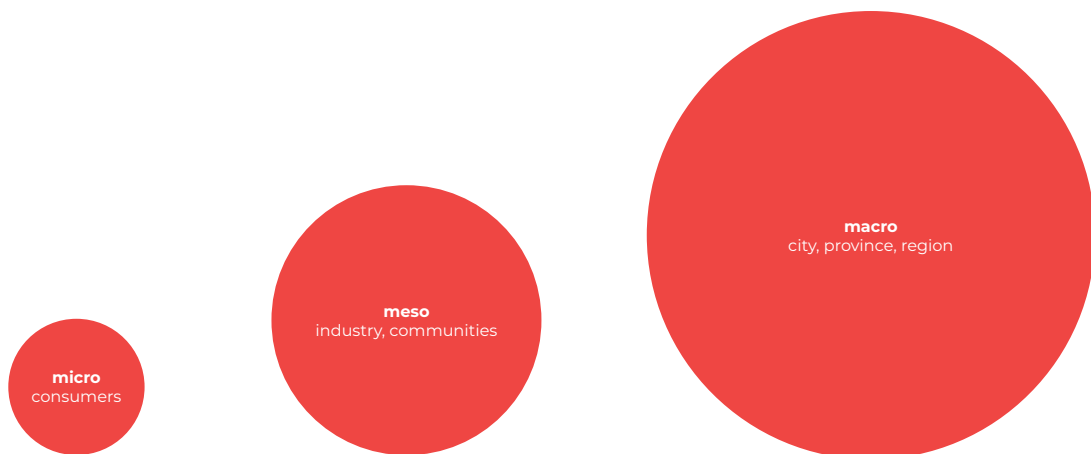


**Figure 3.26.** The Six Design Leverage Points. (Ellen McArthur Foundation, 2013)

Circularity indicators, as noted by Corona et al. (2019), increase public awareness and align with the European Commission's action plan (European Commission, 2015) for reliable indicators. These tools assist stakeholders in understanding CE principles at various systemic levels. Numerous circularity indices and measurement frameworks exist, quantifying product circularity on a scale from 0 to 1 (Corona et al., 2019). These indices serve purposes ranging from product labeling to regulatory change and can be applied at macro, meso, and micro levels, each requiring distinct evaluation methods (Saidani et al., 2017).

## 4.2 Existing Circularity Indicators

While many researchers have explored measuring product or building circularity, there is no universally accepted method. Assessing circularity in products is complex due to its expansive nature. Saidani et al. (2019) categorized 55 circularity indicators by implementation on a micro, meso and macro level (Figure 00), type of loops (maintain, remanufacture/reuse, or recycle), and their purposes (informative, action-oriented, or communicative). They aimed to establish a classification system for circular indicators, recognizing that different indicators may serve distinct purposes. The research highlighted the general lack of reliability in many existing indicators and emphasized the need for a more comprehensive approach that encompasses the three sustainability pillars: Social, Economic, and Environmental parameters as shown in the figure below:



**Figure 3.27.** Different levels of evaluating circularity as defined by Saidani et al. (2017).

Within the construction sector, Cambier et al. (2020) identified 38 design tools, ranging from frameworks providing guidance without quantifying circularity to tools measuring circular attributes like the Building Circularity Indicator (BCI) (Verberne, 2016), Reuse Potential Tool (RPT) (Durmisevic et al., 2017), and Circulytics (Ellen MacArthur Foundation, 2020). The international standard, ISO 20887:2020 (International Organization for Standardization, 2020), details design principles for adaptability and disassembly, offering methods for their evaluation.

## Material Circularity Indicator (MCI)

The Material Circularity Indicator (MCI), developed by the Ellen MacArthur Foundation and Granta Design, assesses product circularity during design and sets benchmarks. It primarily focuses on technical cycle materials, occasionally including biological materials like timber. The MCI evaluates recycled material usage, potential for post-life product reuse, lifespan extension, and efficiency improvement. It scores products from 0 (linear) to 1 (circular) based on:

1. Amount of Virgin Material (V)
2. Product Utility (X), and
3. Unrecoverable Waste (W)

The MCI calculates circularity by considering material input (virgin or non-virgin), material output (energy reclamation or landfill), and technical lifespan. It estimates a product's potential circularity using a Bill of Materials (BOM) as a reference (Verberne, 2016). However, the MCI has limitations, as it doesn't consider product modularity, architecture, or disassembly (Saidani et al., 2019).

## Building Circularity Indicator (BCI)

Verberne (2016) introduced the Building Circularity Indicator (BCI) but faced limitations, particularly in assessing disassembly potential, especially on lower building levels. To address this, Van Vliet (2018) revised the BCI model, introducing a new approach. Alba Concepts and van Schaik (Van Schaik, 2017) further contributed to the discussion, proposing different versions of the BCI. Each stage provides a score between 1 (fully circular) and 0 (completely linear).

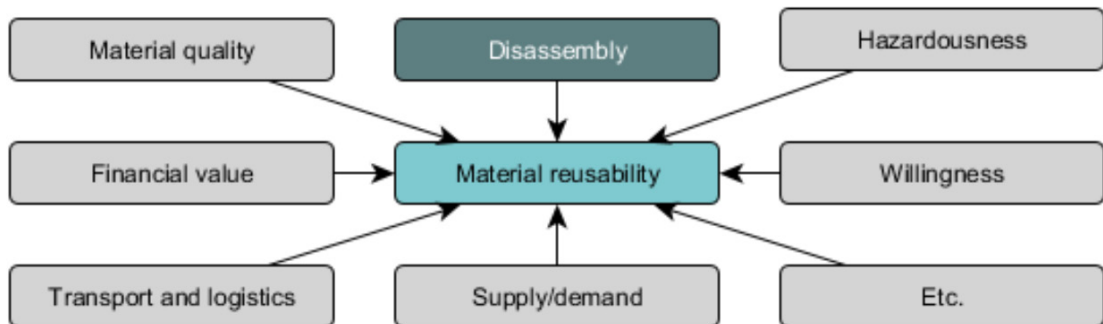
## Predictive Building Circularity Indicator (PBCI)

Cottafava et al., (2021) introduced the combination of two indicators, the Building Circularity Indicator (BCI) and the Predictive BCI (PBCI), which integrate Material Circularity Indicator (MCI), Embodied Carbon (EC), and Design for Disassembly (DfD) criteria. This allows to predict the reclamation potential of materials based on DfD design criteria and in terms of recovered mass. To facilitate inter-building comparisons, they emphasize the need for precise DfD criteria, well-defined boundary conditions, and minimum component evaluations.

This approach is promising, since there is a missing link between estimating the percentage of recoverable material that can be reclaimed based on the design criteria.

### 4.3 Disassembly Potential

Evaluating disassembly potential is crucial for reusing building components. Buildings, complex combinations of materials and components, depend on the ease of separating these elements without losing functionality (Van Vliet et al., 2021).



**Figure 3.28.** Disassembly potential as a factor for reusability. (Van Vliet et al. 2021)

The disassembly potential measurement method proposed by Van Vliet et al. (2021) serves various purposes in construction and sustainability, including evaluation for inclusion in BREEAM-NL sustainability certification. It aids design by creating disassemblable connections and components for material reuse and recycling. Additionally, it tests product disassembly potential for more sustainable building components.

Environmental Performance of Buildings is also linked to disassembly potential assessment. To assess a building's disassembly potential, each product or element within it must be identified, a step preceding environmental assessment. The Environmental Cost Indicator (ECI) of a product serves as a weighting factor for determining the overall building's disassembly potential. Assessors determine the disassembly potential of each building element in its "as-built" state, using a representative Bill of Materials (BOM) from an Environmental Product Declaration (EPD). Different manufacturing methods for the same product or element require separate assessment, ensuring the rating represents most products in the building. Some building products are not relevant to disassembly potential, and the 'Layers of Brand' framework helps identify which elements require assessment based on specific functions within the building.

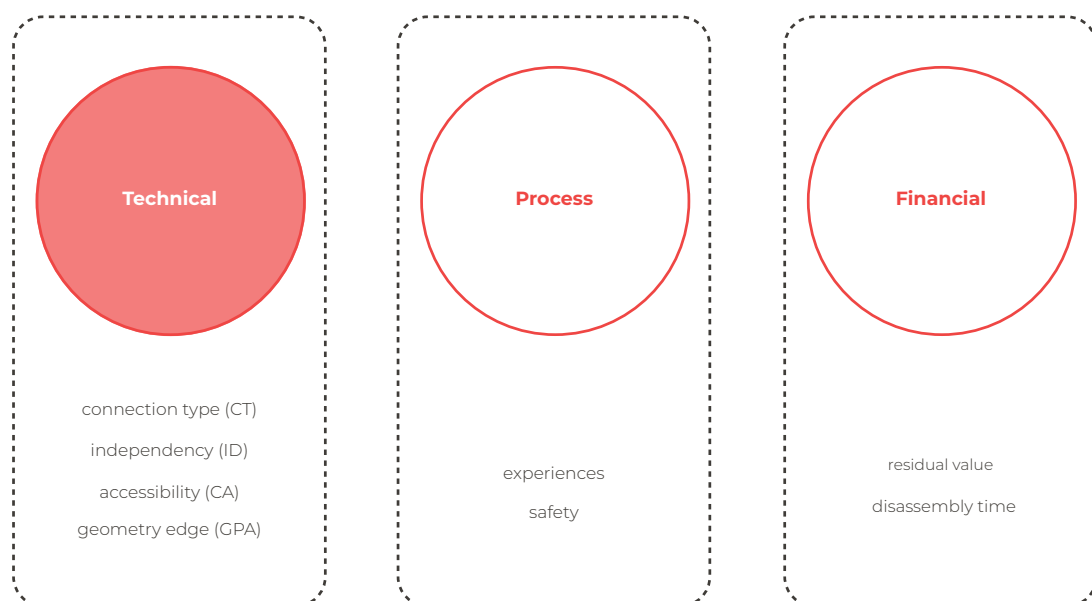
Disassembly potential assessment applies to both new construction and existing buildings.

The measurement should indicate a building's and products' disassembly potential (Durmisevic, 2006), with building design playing a pivotal role in this assessment, impacting technical, process-related, and financial aspects (Van Vliet et al., 2021). Technical aspects assess physical dismantling feasibility, process-related aspects involve control during design and construction, and financial aspects consider the economic feasibility of disassembly versus demolition. However, the mentioned method only takes into account the technical aspect.

Twenty-five factors, categorized as technical, financial, and process-related aspects, influence disassembly potential (Durmisevic, 2006). After narrowing down, it encompasses connection type, accessibility, and compositional disassembly potential, involving a product ease of interim disassembly. It considers factors like independency and product edge geometry when surrounding elements remain.

## Disassembly Potential

The Dutch Green Building Council introduced the Disassembly Potential Assessment Method in collaboration with Van Vliet et al. (2021). However, the Disassembly Potential Indicator proposed by Van Vliet et al. (2021), only analyzes the technical disassembly capacity. For the purpose of this research also Disassembly Time and resulting Residual Value as in Reclamation Potential will be evaluated to give a more holistic picture.



**Figure 3.29.** Disassembly Potential Criteria. Adapted from (Van Vliet, 2021).



## 4.4 Disassembly Time

Apart from disassembly potential indicators, alternate methods evaluate disassembly time. This can be achieved through direct measurement or calculation using product parameters (Vanegas et al., 2018). Direct measurement entails assessing disassembly times for similar products but has limitations such as labor intensiveness, susceptibility to human factors, and difficulties in accommodating design changes without new measurements (Recchioni et al., 2016).

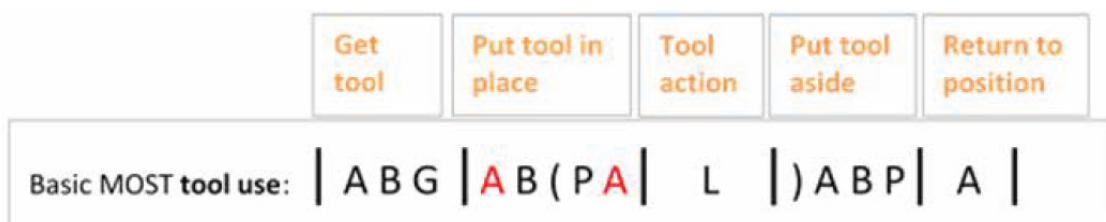
Calculating disassembly time involves two primary approaches in the literature: one based on product and connector properties, exemplified by the U-Effort Model by Sodhi et al. (2004), and another centered on fundamental disassembly task motions. Methods falling under the latter approach include MOST (Zandin, 2020), Philips ECC (Boks et al., 2002), Kroll Method (Kroll and Hanft, 1998), and eDiM (Vanegas et al., 2018).

### U-Effort Model

Sodhi et al. (2004) introduced the U-effort method to optimize Design for Disassembly (DfD) by calculating disassembly time for connectors based on their physical properties, using the unfastening effort index (UFI) to assess key attributes like size and shape. However, it is a time-consuming method.

### Maynard Operation Sequence Method (MOST)

MOST estimates assembly times across various products, reflecting the performance of an average-skilled operator (Zandin, 2003). MOST provides pre-modeled tasks and a process for adding new ones, involving sequences like General Move, Controlled Move, and Tool Use, including actions for horizontal and vertical movements, equipment control, placement, and loosening processes.



**Figure 3.30.** Disassembly Operation Sequence Technique (MOST) . Adapted from (De Fazio et al., 2021).

## **Philips ECC**

The Philips ECC method, proposed by Boks et al. (1996) for Philips products, estimates disassembly time using a database with times for common connectors and specific tasks like tool changes. These times were based on actual disassembly sessions, with little variation noted across different connector types or tasks. The model calculates handling, tool operations, and disconnection time using this database once provided with a disassembly sequence and connector type.

## **Kroll Method**

Kroll proposed a method to identify opportunities to reduce disassembly time, basing calculations on MOST and hands-on disassembly experiments with various electronic devices (Kroll, 1996). This method outlines 16 basic disassembly tasks, categorized by accessibility, positioning, force, and special non-standard aspects (Kroll and Hanft, 1998; Justel-Lozano, 2008). While the method assumes the operator is familiar with the disassembly process and has necessary tools, Kroll utilized it to quantify and compare the disassemblability of diverse product designs, track design enhancements, and predict disassembly costs (Boks et al., 1996; Hanft and Kroll, 2012).

## **eDiM Method**

The eDiM method is proposed by Venegas et al. (2018) in a joint effort with the European Commission, which calculates disassembly time using the Maynard operation sequence technique (MOST). eDiM employs a simple calculation sheet (Appendix 10.5.) based on action sequences and basic product information, ensuring clear and verifiable results. A unique feature of eDiM is its categorization of disassembly tasks into six groups, shedding light on design improvement areas. The method shows its potential for policy contexts and offers manufacturers insights into enhancing product disassemblability. The findings from this research indicate that the suggested method can yield accurate outcomes even with minimal input details.

The existing assessment methods quantitatively simplify disassembly actions, offering designers tools to predict the ease of future disassembly and translate these predictions into cost implications. However, their applicability to building components hasn't been tested. Furthermore, quick disassembly doesn't always correlate with optimal material reclamation or end of life considerations, posing challenges in objectively evaluating disassembly efficiency. These methods would require a database to compare different outcomes.

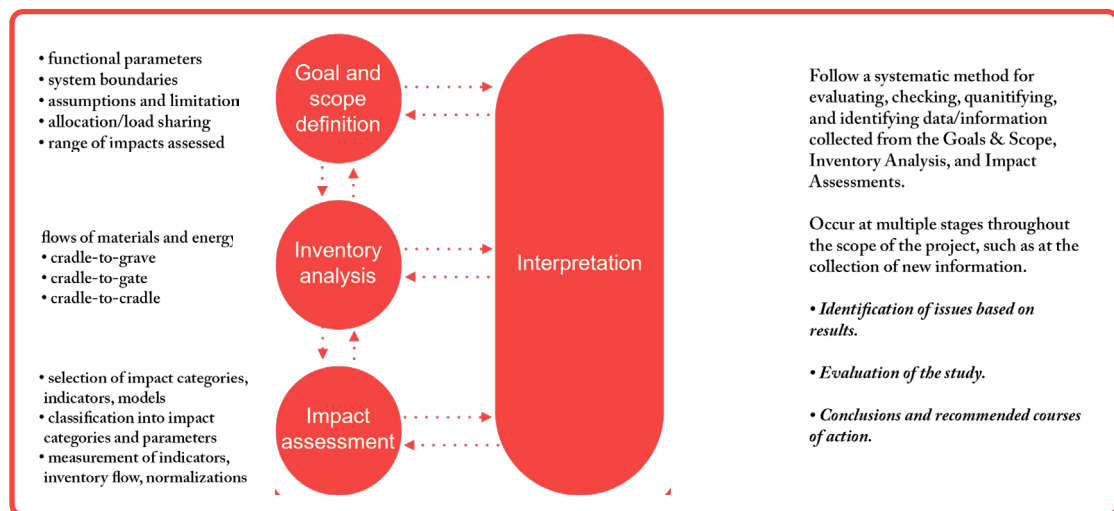
## 4.5 Environmental Indicators

"Sustainable development is development that meets the needs of the present without compromising the ability of future generations to meet their own needs." (Brundtland & Khalid, 1991)

In the building sector, the adoption of sustainable design and construction has been steadily increasing over time. This growing trend reflects an enhanced understanding of the connection between buildings and the environment, resulting in the proliferation of standards for evaluating the sustainability of materials and design methods (Allen & Iano, 2019). For this purpose, Life Cycle Assessment (LCA) represents a structured environmental analysis and accounting technique used to evaluate the ecological impacts of products or services across their entire lifespan. This method adopts a systematic and quantitative approach, mapping out the entire value chain, from resource extraction to end of life considerations (Arup & Saint-Gobain, 2021).

### Background on Life Cycle Assessment (LCA)

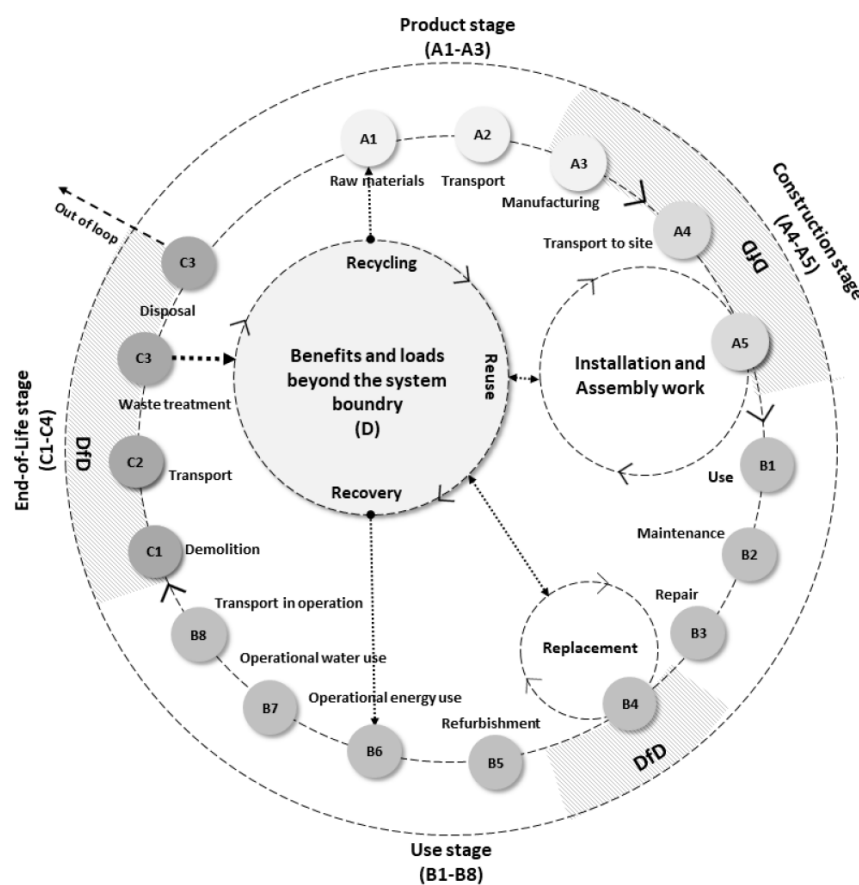
The concept of life cycle assessment (LCA) emerged in the late 1960s but gained substantial attention in the mid-1980s. In 1994, the International Standards Organization (ISO) began developing LCA standards as part of its 14000 series on environmental management (Åke & Tawfic, 2011). These standards encompass both the technical details and the conceptual framework as shown in Figure 3.31:



**Figure 3.31.** Life Cycle Assessment Framework. Adapted from (Åke & Tawfic, 2011).

## Link Between LCA and Design for Disassembly

The LCA framework assesses building environmental performance through modules: production (A1–A3), implementation (A4–A5), use (B1–B7/B8), end of life (C1–C4), and an additional module (D) accounts for net impacts beyond the system boundary, considering reuse and material recycling (Lausselet et al., 2023). These modules rely on calculations, primarily involving material volume multiplied by emission factors from Environmental Product Declarations (EPD) (Lam et al., 2022). Applying a circular economy perspective transforms the linear LCA model into a loop, as illustrated in Figure 3.32.



**Figure 3.32.** Circular approach and the implication of DfD in LCA. (Lausselet et al., 2023).

Design for Disassembly (DfD) offers the potential advantage of reducing both resource consumption and the environmental impact by eliminating the need for raw material extraction and manufacturing (Lam et al., 2022). However, the precise methods for quantifying and incorporating these environmental benefits into existing regulations or standards have not been clearly established, necessitating further investigation and clarification (Lausselet et al., 2023).

## **Limitations of Design for Disassembly Considerations in LCA**

Life Cycle Assessment (LCA) is frequently used to measure the environmental impact of buildings and their solutions. Yet, the prevailing European standards are designed to evaluate linear life cycles rather than multiple or circular ones, as shown in previously conducted research (Brancart et al., 2021). The examination of standards and methodologies reveals a current absence of explicit guidelines regarding carbon emissions in Design for Disassembly (DfD). In practical terms, this uncertainty translates into ambiguity concerning the implications of enabling the disassembly and reuse of building components or materials during a building's disposal or deconstruction in terms of carbon emissions (Lausselet et al., 2023).

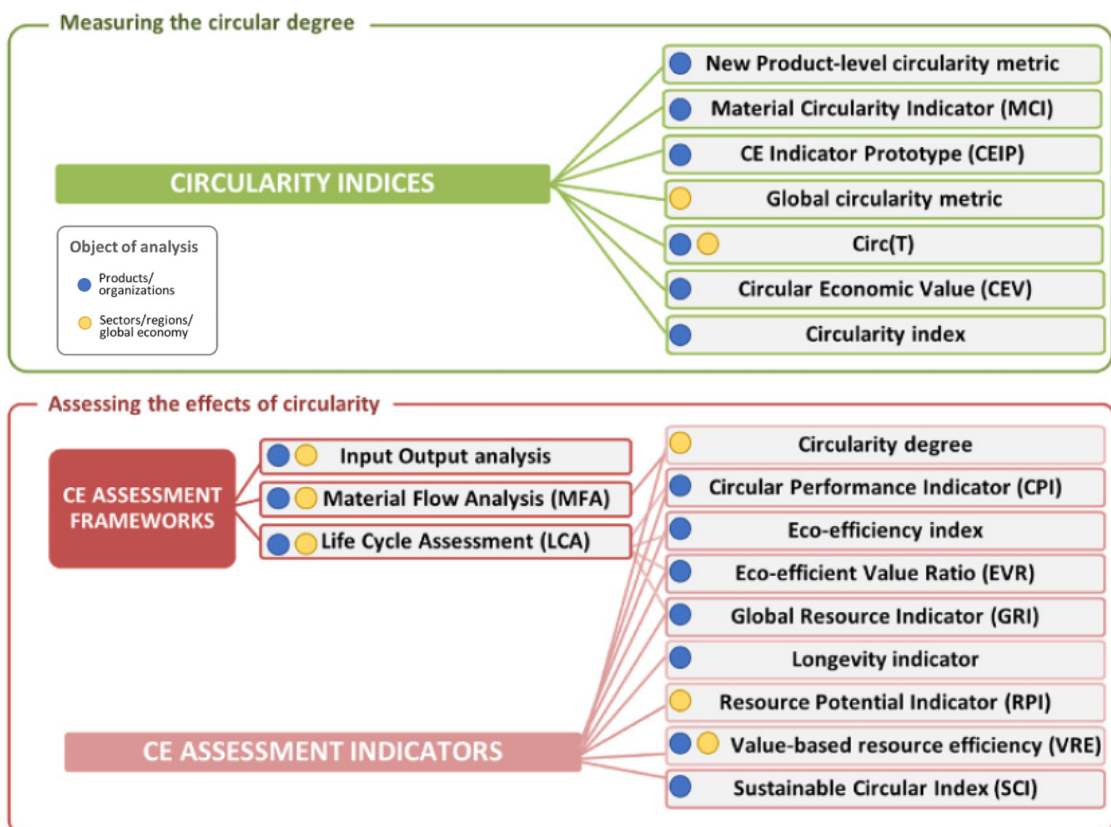
One approach to address these challenges involves adopting different allocation methods, such as the Circular Building Life Cycle Assessment (CE LCA) or incorporating customized replacement scenarios, evaluated comparatively against conventional business-as-usual references (Brancart et al., 2021). However, it is important to note that results may significantly differ based on the specific user scenarios considered. Façade-related LCAs, in particular, have primarily concentrated on modules A and B, occasionally extending to module C. Many assessments of module D in the end of life phase assume typical disposal scenarios without comparing reclamation strategies (Overend & Hartwell, 2019).

The analysis of standards related to the consideration of embodied carbon calculations in Design for Disassembly (DfD) reveals a current lack of clear guidelines (Lam et al., 2022). Consequently, the environmental impact of DfD practices in buildings remains uncertain, and existing standards do not incentivize DfD in new construction. To address this issue, Lausselet et al. (2023) provide valuable insights for policy-making, where future studies should consider aspects such as the allocation of future emissions savings, the importance of product reusability and emission factors for reusable products. Additionally, they should assess the effectiveness of DfD compared to other embodied carbon reduction measures and explore potential innovation incentives in cases of uncertainty regarding future emissions reductions and the mentioned design strategies.



## 4.6 Comparing Different Indicators

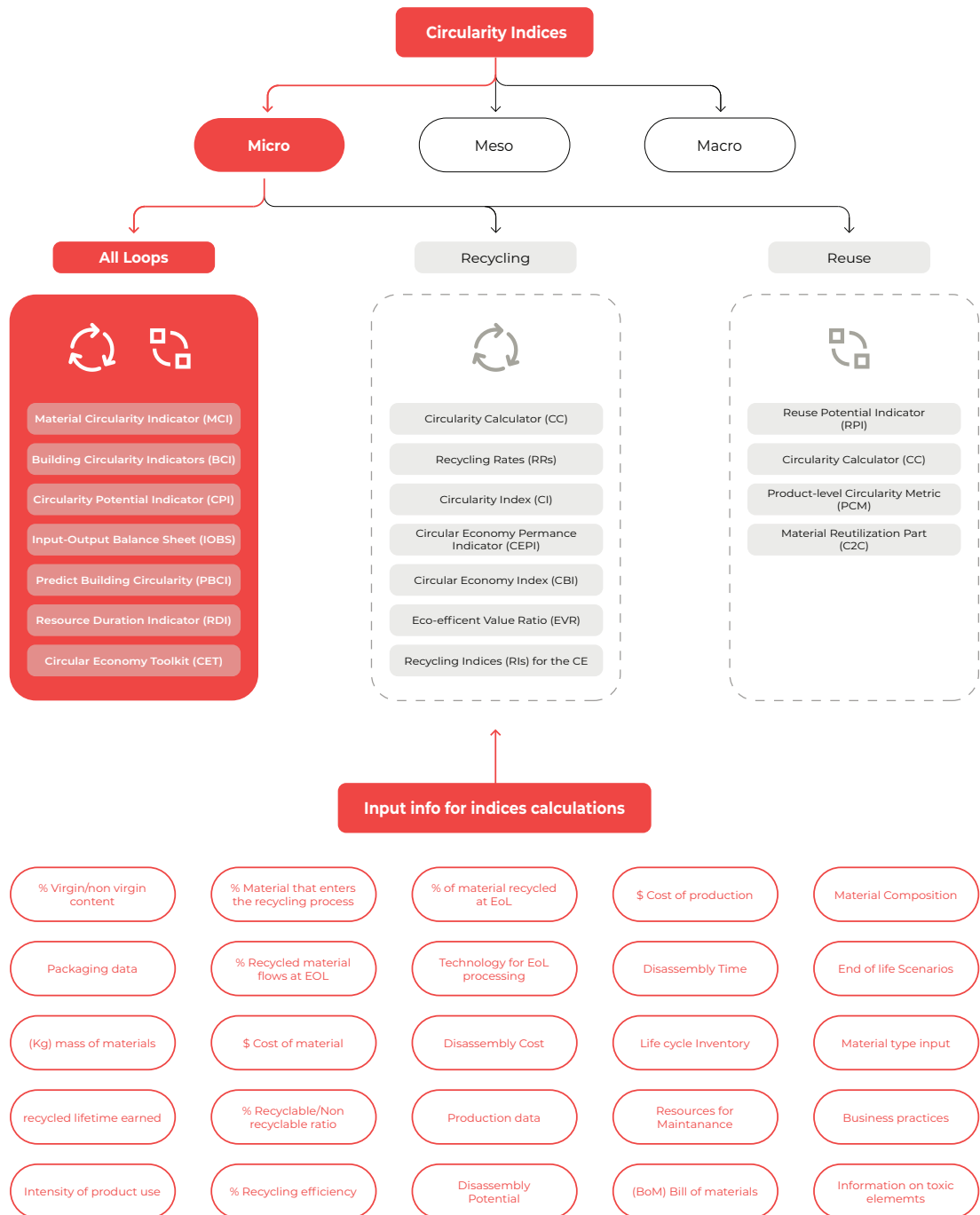
The research underscores diverse circularity indicators with varied interpretations, lacking key resource considerations. Life Cycle Assessment (LCA) shows promise for assessing circularity at product and service levels, considering emissions. Aligning circularity assessments with circular economy concepts, as highlighted by Linder et al. (2017), is crucial. In their evaluation, Corona et al. (2019) categorized assessment methods into Circularity Measurement Indices and Circularity Assessment Tools (Figure 3.33), considering environmental, ecological, and societal aspects.



**Figure 3.33.** Reviewed circularity metrics. (Corona et al., 2019)

Regarding disassembly time, the assessment systems discussed in Section 4.4 effectively simplify disassembly tasks in a quantitative manner. Additionally, they enable designers to assess the ease of future disassembly and estimate associated costs based on time and required tools and actions, which has been observed as important in assessing disassembly potential on a building level.

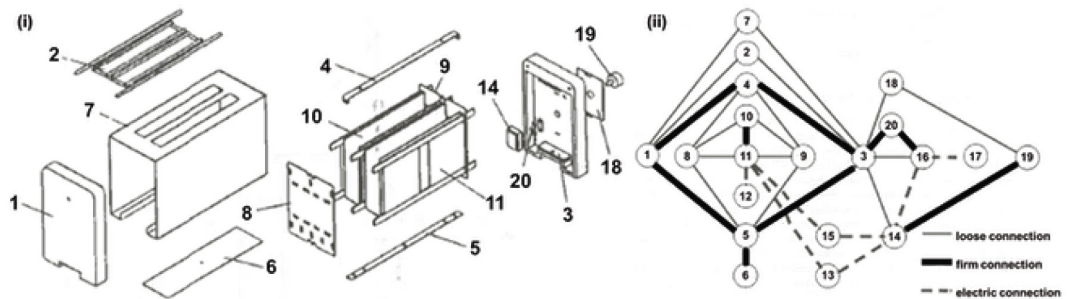
Figure 3.34 depicts the complexity in quantifying indicators like disassembly potential, reuse possibilities, recycling content, which relate both to quantitative measures and to building design which is qualitative in essence. To calculate material value retention loops, diverse data types are needed. Integrating material passports and databases can help organize the required information and can enhance stakeholders perspective.



**Figure 3.34.** Assessment methods and required data input for performing calculations. (Author)

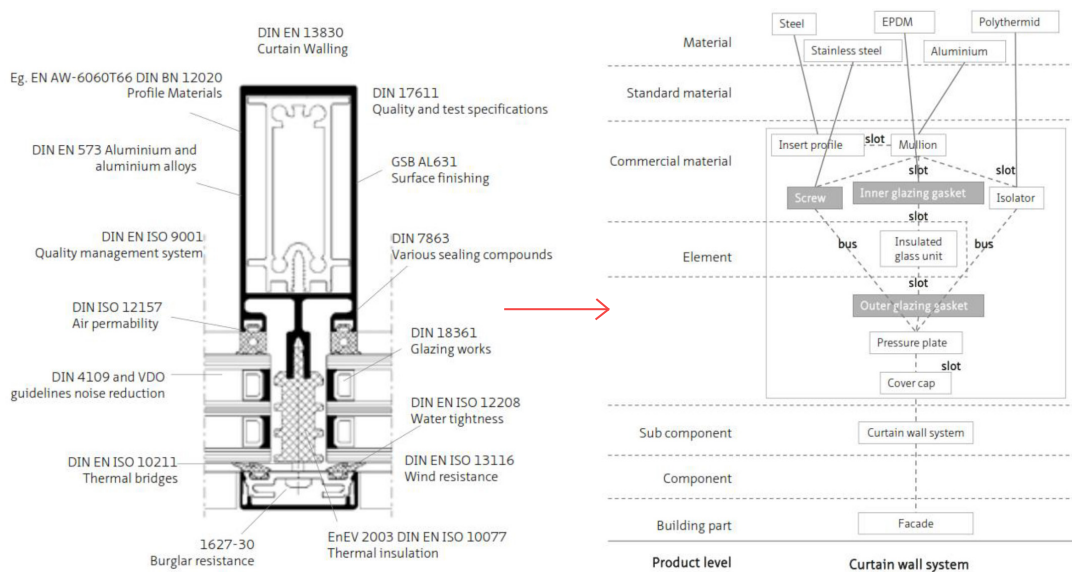
## 4.7 Disassembly Mapping and Relational Diagrams

Various methods address disassembly difficulty, including disassembly modeling approaches like those proposed by De Fazio et al. (2021) and Lambert & Gupta's (2008) connection diagrams. These diagrams, as illustrated in Figure 3.35, depict connections between parts and their types, aiding in disassembly operation identification and revealing challenges associated with permanently connected components (Overend & Hartwell, 2019).

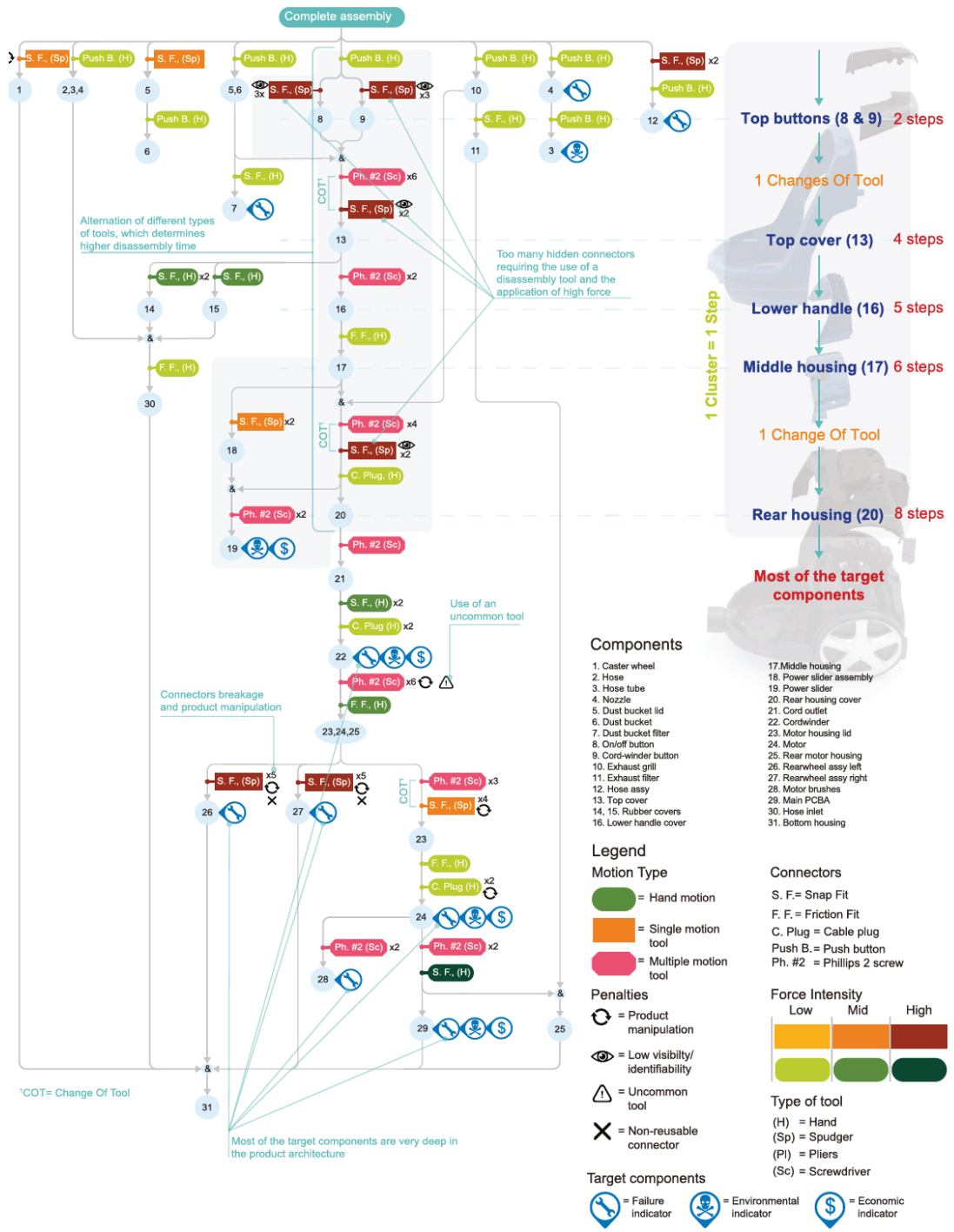


**Figure 3.35.** Exploded view of a toaster, identifying elements (left). Connection diagram of a toaster (right). (Lambert & Gupta, 2008)

Klein (2013) takes a more in-depth approach by presenting a comprehensive façade function tree based on product design. To analyze these façade, product architecture is used (Ulrich, 1995) which involves mapping components and specifying the interfaces and relational patterns between these (Figure 3.36).



**Figure 3.36.** Typical curtain wall (left), product levels and relational diagram (right). (Klein, 2013)



**Figure 3.37.** Disassembly Map of the original architecture of vacuum. (De Fazio et al., 2021)

De Fazio et al. (2021) introduced the "Disassembly Map" method, visually aiding product disassembly for easy access to failure-prone components. It aligns with reparability standards and assesses disassembly ease using design parameters like sequencing, tools, connection type, and time for disassembly, without relying on algorithms, but encourages designers to analyze each step visually (Figure 3.37).

## 4.8 Conclusions

In the pursuit of a more sustainable built environment, the integration of circular economy principles into the construction industry is a pressing need. This chapter has delved into various facets of measuring circularity and forecasting end of life scenarios for building façades, shedding light on the complexity of this multifaceted challenge.

Design for Disassembly principles are often not prioritized in the design process. Stakeholders in the building industry, such as in the façade industry, mentioned that the advantages of designing for reuse, remanufacturing, and recycling would need to be quantified to justify its inclusion (Hartwell & Overend, 2020). Assessing the end of life benefits of Design for Disassembly as well as predicting the potential reclamation of materials is essential. Specific product design is crucial as it also represents the financial resources necessary for product disassembly (Sonnenberg, 2001). In addition to life-cycle assessments, more comprehensive environmental assessments tailored to multi-material assemblies are needed to better evaluate the benefits and trade-offs associated with material selection and connection methods to optimize material reclamation (Beurskens et al., 2016; Durmisevic et al., 2017).

Incorporating Design for Disassembly in the early stages of building component design is crucial in determining the product's structure (Kroll & Hanft, 1998). Design tools that improve the understanding of the disassembly process and assist in evaluating alternative designs are thus highly significant. In this chapter, various methods and tools have been examined to improve circularity in construction.

The proliferation of assessment tools signifies substantial progress in analysis development, but a robust indicator must span a product's entire lifecycle from design to end of life. It is noteworthy that access to many of these tools is often restricted, some requiring financial incentives, potentially affecting their reliability. Accurate indicator computation necessitates comprehensive data across the value chain, often requiring supply chain actors to provide data, which can be tackled using tools such as material passports, making data more accessible.

# 5 Conceptual Framework

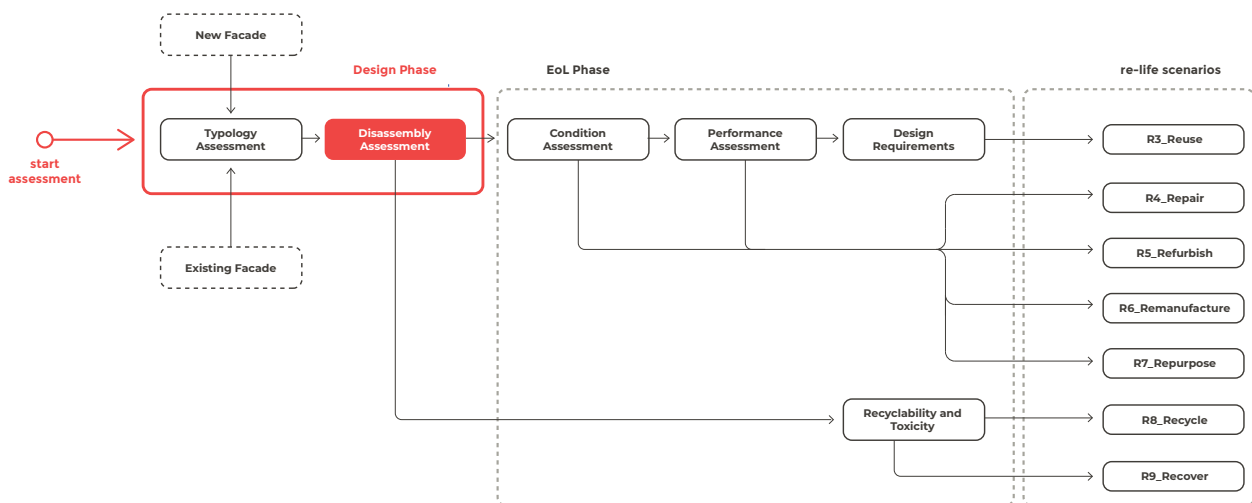
5.1	Introduction	65
5.2	Information Inputs and Outputs	67
5.3	Stakeholder Profiles	68
5.4	Information Model	69
5.5	Databases	71
5.6	Conclusion	72



## 5.1 Introduction

Efficiently reclaiming materials from façade systems for reuse and recycling is a promising circular economy strategy, reducing carbon emissions and waste. However, the conducted literature review highlights that considerations about disassembly and component reclamation at End of Life (EoL) often lack attention in design and deconstruction phases.

Figure 3.38 illustrates the conceptual framework, offering insights into the performance of diverse design alternatives and the potential for reclaiming materials from existing façades at their end of life.



**Figure 3.38.** Conceptual framework to evaluate reclamation potential of facade systems. (Author).

The following chapter will outline the conceptual framework to conduct the disassembly assessment based on design for disassembly criteria. The focus of this chapter specifically is the required data, how to structure it in a manageable way and which stakeholders are involved in the process.

### Limitations and Boundaries

The objective was to analyze current façades to illustrate the efficacy of the suggested assessment framework for disassembling components and, in turn, reclamation of materials. It serves as a demonstration of the necessary documentation process for the framework, database creation, visualization and calculation methods, which result in a holistic façade disassembly assessment framework for the reclamation potential and subsequently informs the design process.

## Phases of a Circular Façade Lifecycle

Based on the findings from the literature review (Konstantinou et al., 2023; Hartwell et al., 2021), the circular lifecycle of a façade involves information flows to make informed decisions for the design and EoL phase. Through the assessment of the design, EoL decisions can be made and viceversa. Recent industry developments show growing interest in assessing the EoL Phase aswell, especially with detailed façade data potentially creating opportunities for reclamation auditors (Konstantinou et al., 2023).

### 1. Design Phase

This initial phase involves the translation of client and architect requirements into a feasible façade design. In this phase Design for Disassembly is assessed.

### 2. Forward Logistics

At this stage, the designed façade is transformed into a manufacturable and functional product that is then installed on the building.

### 3. Operate and Maintain

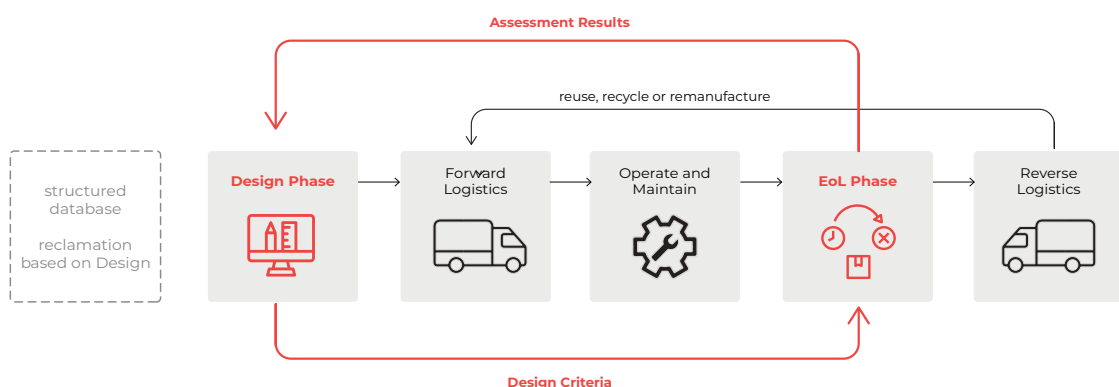
During this phase, the façade is utilized within the building, and regular maintenance is conducted to ensure its long-term performance.

### 4. End of Life Phase

Due to the growing nature of the Circular Economy for Façade Systems, this proposed stage focuses on collecting information about the façade and making decisions regarding the most valuable treatment of the materials.

### 5. Reverse Logistics

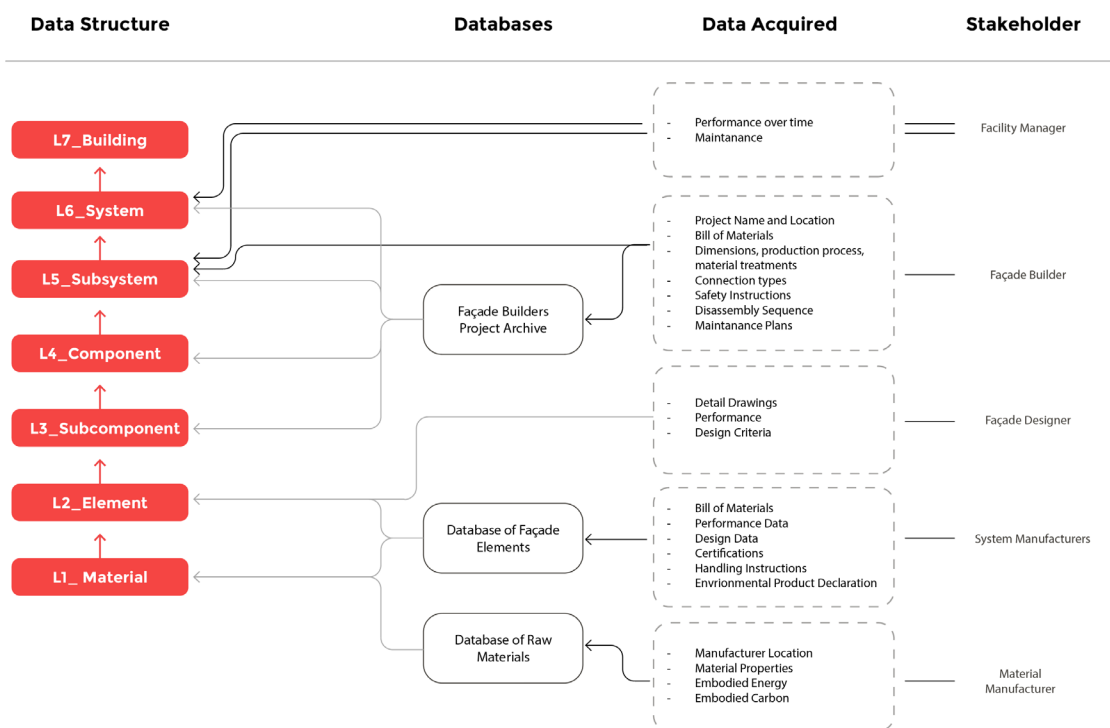
Following the EoL assessment, this phase involves the deconstruction of the façade and the transportation of its materials to their respective final destinations.



**Figure 3.39.** Assessment Phases during thhe circular lifecycle of a façade. (Author)

## 5.2 Stakeholder Collaboration

The assessment process, as shown in Figure 3.39, involves several key substages. For the design phase, the design for disassembly criteria are taken into account to assess the potential of the façade components going back into a circular lifecycle. For the end of life assessment, a reclamation auditor is crucial. The auditor can gather building information and perform a comprehensive end of life assessment based on the existing design. This approach informs the Reclamation Auditor and provides valuable insights for Façade Engineers and Designers for new projects. Figure 3.40 depicts the information flow among these stakeholders.



**Figure 3.40.** Stakeholders and information flows in the circular lifecycle of a façade. (Author)

### Focus on Façade Engineers and Designers

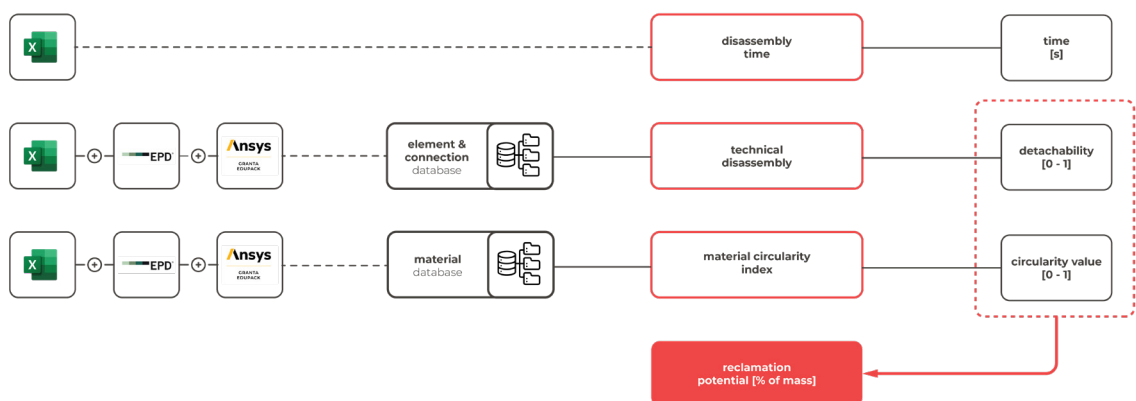
Translates architects' and MEP consultants' requirements into a detailed design, specifying materials and assembly methods. This stakeholder can use the proposed workflow to benchmark the design in an iterative process.

### Focus on Reclamation Auditors

Possess technical knowledge of façade disassembly and reuse. This stakeholder can assess the potential for reclamation based on design for disassembly.

## 5.3 Information Input

The main objective is to identify the reclamation potential scenario for the façade based on available information, from the design phase to the potential reclamation of materials based on the design at End of Life phase. Figure 3.41 provides a visual representation of the required information inputs and outputs to conduct the assessment in the Design and EoL phase of a façade system. For existing façade systems, the assessment process can be regarded for the EoL Phase in the lifecycle of existing buildings destined for demolition (Konstantinou et al., 2023). This separation is necessary due to the additional time required to collect and organize information, typically stored in unstructured formats such as documents, for manual analysis in order to conduct the assessment.



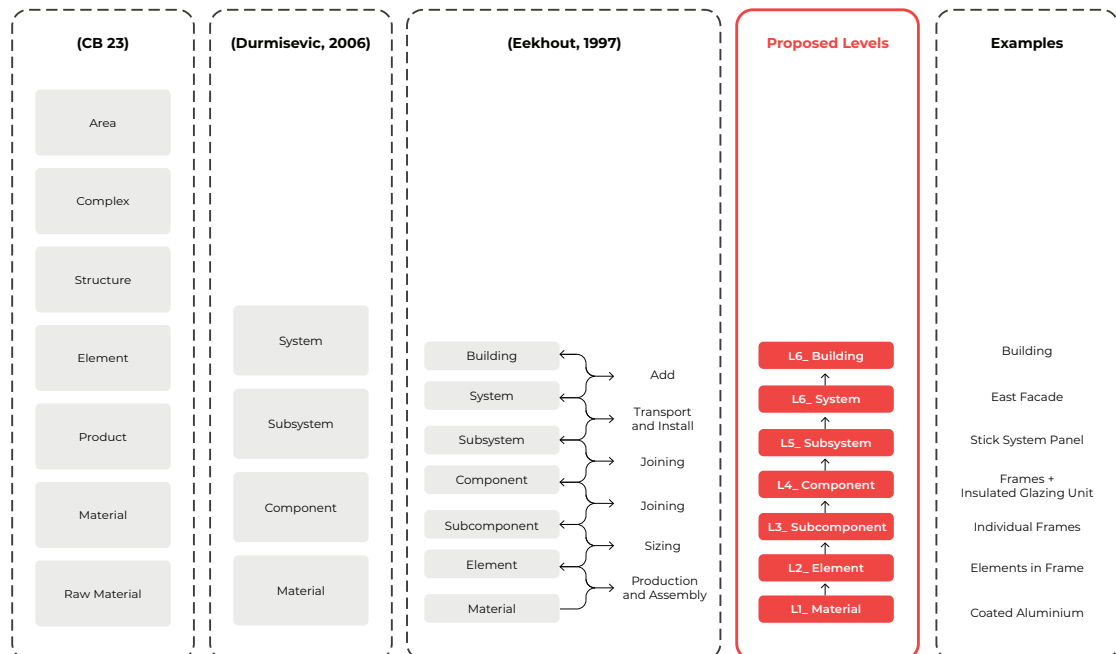
**Figure 3.41.** Overview of the proposed data inputs and outputs. (Author)

Eventually, when tools such as material passports become regulated and structured information is more readily available, automated data processing through algorithms will enable assessments to be conducted in the design stages, operational phase and deconstruction phase (Konstantinou et al., 2023).

## 5.4 Information Model

### Hierarchy of Product Levels

Building façades can be classified into different product and material levels, as discussed by Klein (2013), who identified eight distinct levels and presents an elaborate façade function tree based on product design. These components are interconnected through interfaces. To maintain consistency (Eekhout, 1996) structure for product hierarchies was chosen as the basis and customized to suit the proposed workflow (Figure 3.42).



**Figure 3.42.** Existing definitions of product tiers within buildings, adapted to façades and suggested relationships information levels. Adapted from (Michael, 2016; Eekhout, 1996)

This hierarchy helps distinguish elements when it comes to understanding the complex assembly of façades. It provides a visual output which also allows to distinguish the different connection methods between each level, for easy identification purposes. This hierarchy will be used to assign different information databases which allow for the evaluation of the different modules within the proposed workflow.

## Data Collection and Organization

Based on Heinrich and Werner's framework (2019), an extensive database about façade products and components can be compiled. This data can be classified using various criteria, as shown in Figure 3.43, illustrating the diverse information in façade product passports. However, it is a very extensive list and methods to automate this process could be explored.

organization	item	description
source	CE Download Portal EPD Manual Input	CE marks available through supplier Download portal from companies Environmental Product Declaration In form of Excel tables
type	Documents Drawings Value Text Multiple	Information from Word documents or PDF CAD Files and BIM Models Unit Characters when type is n/a
hierarchy level	L1_ Material L2_ Element L3_ Subcomponent L4_ Component L5_ Subsystem L6_ System L7_ Building	Materials used for the products. Elements which are produced from the materials. Combination of elements General combination of subcomponents For instance, a facade panel For instance, building skin Building location and relevant data
category	Design Data Environmental Data Manufacturing Data Material Properties	Based on the categories proposed by (Heinrich, et al., 2019)

**Figure 3.43.** Data organization types as proposed by Heinrich and Werner (2019). Adapted from (Heinrich and Werner, 2019)

Based on the organization type, a data list can be made, where products are classified for the specific project to be analysed.



## 5.5 Databases

Façade data related to material properties and design parameters are typically stored in various formats like BIM Models, CAD drawings, spreadsheets, or documents. In a material passport, each façade component gets a unique ID for traceability, offering opportunities for stakeholders in design and end of life stages to access essential data. Organizing façade-related information into product levels, as outlined in Section 5.4, involves distinct data sets at each level. To streamline data input and improve data quality, distributing these levels across separate databases is proposed. These Databases could eventually be linked to reference different information related to components and systems.

### Materials Database

This refers to a database that can contain information regarding the materials used in a façade assembly. Such databases exist, such as the Granta Edu Pack Database (Ansys, 2022). If manufacturers provide the data on the raw materials, this can also be used or extracted from Environmental Product Declarations (EPD). Material information is important to assess different indicators as discussed in the previous chapter.

### Process Database

1. Materials Process Database: Refers to the information related to the production process of the elements and materials. There are many processes involved in assembling a façade, from material extraction, to transportation, to manufacturing and assembly. Information can be from manufacturers and EPDs or complemented with other existing databases such as Granta EduPack.
2. Disassembly Process Database: database records necessary steps for disassembly, disassembly tasks and tools facilitating time calculations and documenting the necessary parameters to successful disassembly at EoL.

### Connection Database

The connection database may contain details like the estimated time for disassembly, based on the connection type. This database can include necessary tools based on the connection types and the disassembly tasks. Therefore, if a specific component is linked to another using a screw, the pertinent information can be accessed by referring to the identifier "snap-fit" in the façade.

## 5.6 Conclusion

This chapter highlights the conceptual framework for assessing reclamation potential of façade systems. Utilizing the framework for data management of material passports and integrating BIM databases has the potential to streamline the evaluation process, making it more comprehensive and helping stakeholder engagement. Comprehensive databases, providing key details about component attributes, quantities, and relationships, can become instrumental. These databases not only bridge information gaps but also facilitate a shared understanding among stakeholders. While the potential to assess existing façades is evident, a systematic approach encompassing documentation, database creation, visualization, and calculations is essential to develop a comprehensive façade disassembly assessment framework.

### Potentials

1. Material passports and BIM databases support data-driven disassembly assessments, facilitating collaboration among stakeholders.
2. The framework can be adapted to different façade typologies and building components, making it versatile and applicable in various contexts.

### Challenges

3. Data collection and organization can be extensive and may require automation to streamline the process.
4. This chapter has set boundaries to manage time and data constraints, potentially limiting the depth of exploration in certain areas.

Overall, this chapter lays the foundation for the following assessment modules.





Source: (Hutsch, 2018). Unsplash.com



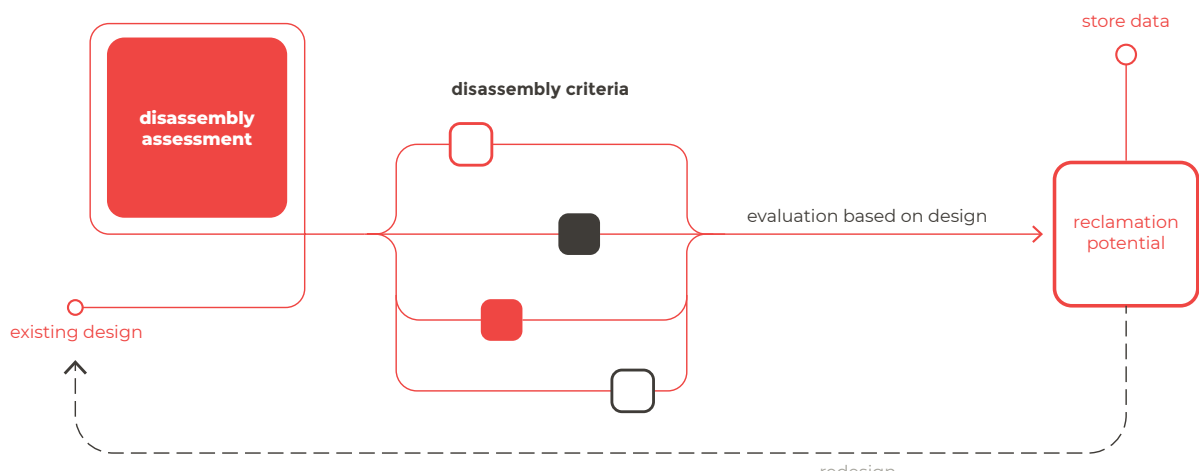
## 6 Assessment Modules

6.1	Introduction	75
6.2	Assessment Criteria	76
6.3	Process Map	77
6.4	Façade Typology Selection	78
6.5	Design Phase: Technical Disassembly Potential	79
6.6	Design Phase: Material Circularity Indicator	80
6.7	Design Phase: Reclamation Potential	81
6.8	Design Phase: Disassembly Time	82
6.9	EoL Phase: Recyclability Module	83
6.10	EoL Phase: Reuse and Remanufacturing	84
6.11	Conclusions	86

## 6.1 Introduction

The following chapter presents the distinct modules that represent the proposed disassembly assessment framework for façades.

The primary goal of the different assessment modules is to give stakeholders insight into the effect of design for disassembly on the reclamation of materials at EoL. Until streamlined material passport structures and software are developed, the process can be considered a separate lifecycle stage for both existing and potentially new façade designs. However, with the eventual availability of structured data, automated information processing through algorithms can expedite and enhance assessments during both the design and end of life phases. The process is broken down into the design phase and EoL phase. The design phase is the primary focus of this research, as this can inform the potential to reclaim materials at an eventual End of Life situation. The process is outlined in Figure 3.44.



**Figure 3.44.** Processes logic for disassembly assessment to assess reclamation potential of new and existing facade systems. (Author)

### Limitations and Boundaries

The goal is not to delve deeply into the functioning of material passports, rather it is about the implications of existing and to-be designed façades to showcase the framework's utility in assessing the disassembly of elements.

## 6.2 Selected Assessment Criteria

In the current context, no universally accepted framework exists for determining the reclamation potential based on Design for Disassembly principles for façade systems. However, various literature sources (Van Vliet et al., 2021; Durmisevic, 2006; Cottafava, 2021; Verberne, 2016; Vanegas et al., 2016; De Fazio et al., 2021) and the established NEN 2767 provide metrics for assessing disassembly ease and building component condition during operation and end of life.

Criteria taken into account in this study are illustrated in Figure 3.45. Through the conducted literature review, a gap was identified related to assessing disassembly time and residual value in the context of the Design for Disassembly evaluation method proposed by the Dutch Green Building Council's Disassembly Potential (Van Vliet, 2021). The proposed method aims to address this gap and explore the integration of disassembly time on reclamation potential factors into the evaluation process.

1. **Quantitative Assessment Criteria:** These criteria lead to straightforward output decisions with minimal room for human interpretation, potentially can be assessed using processing algorithms when more data becomes available.
2. **Qualitative Assessment Criteria:** These criteria can sometimes lead to numerical values. They primarily describe facets of design that involve a certain degree of subjectivity for human decision-making.

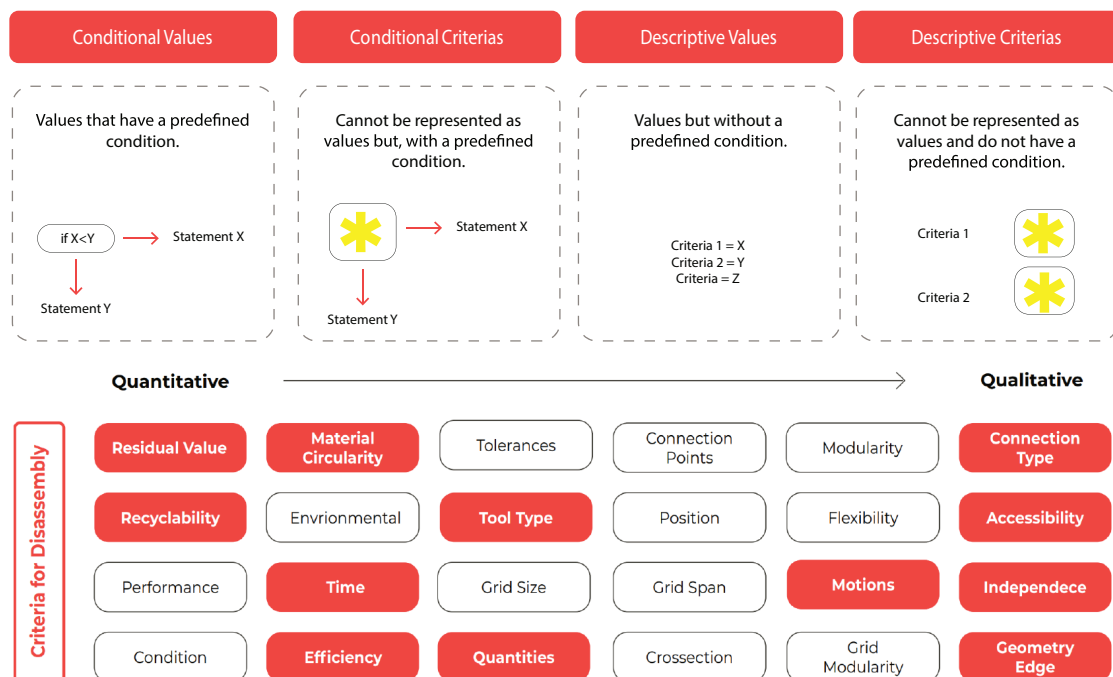


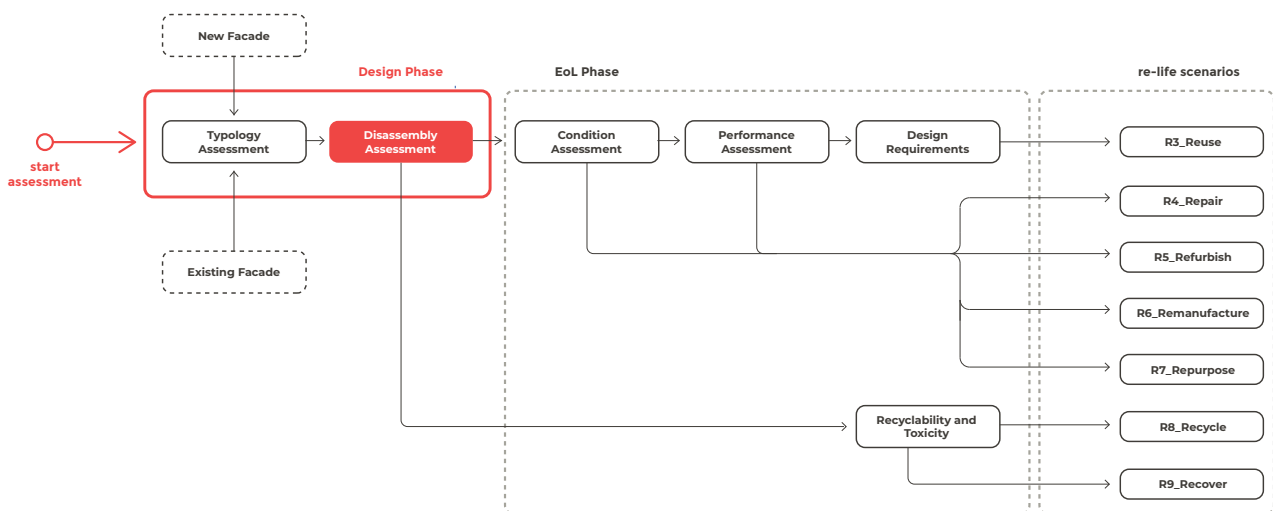
Figure 3.45. Assessment Criteria from quantitative to qualitative factors. (Author)



## 6.3 Process Map

After organizing the information as detailed in Chapter 05, the assessment can begin as described in later sections. During the design stage, designers can evaluate various design options for material reclamation potential at the EoL phase. In the EoL phase, based on design evaluations, the reclamation auditor liaises with stakeholders to decide on the façade's disassembly or demolition's feasibility.

Assessments using disassembly criteria establish feedback mechanisms to optimize the reclamation value of a façade design. The criteria have been structured into decision trees, laying the groundwork for a potential computational tool. This tool operates iteratively, aiming to determine the best re-life value, such as reuse, based on various qualifications.



**Figure 3.46.** Process map to assess Reclamation Potential and Disassembly Time. (Author)

1. Design Phase: During the Design Phase, the assessment can be conducted to predict the reclamation potential based on Disassembly criteria.
2. EoL Phase: Here the different re-life scenarios can be evaluated of a façade at EoL, based on an existing design.

The following sections will outline the different modules. However, for the context of this research, emphasis will be made on the Disassembly Assessment module.

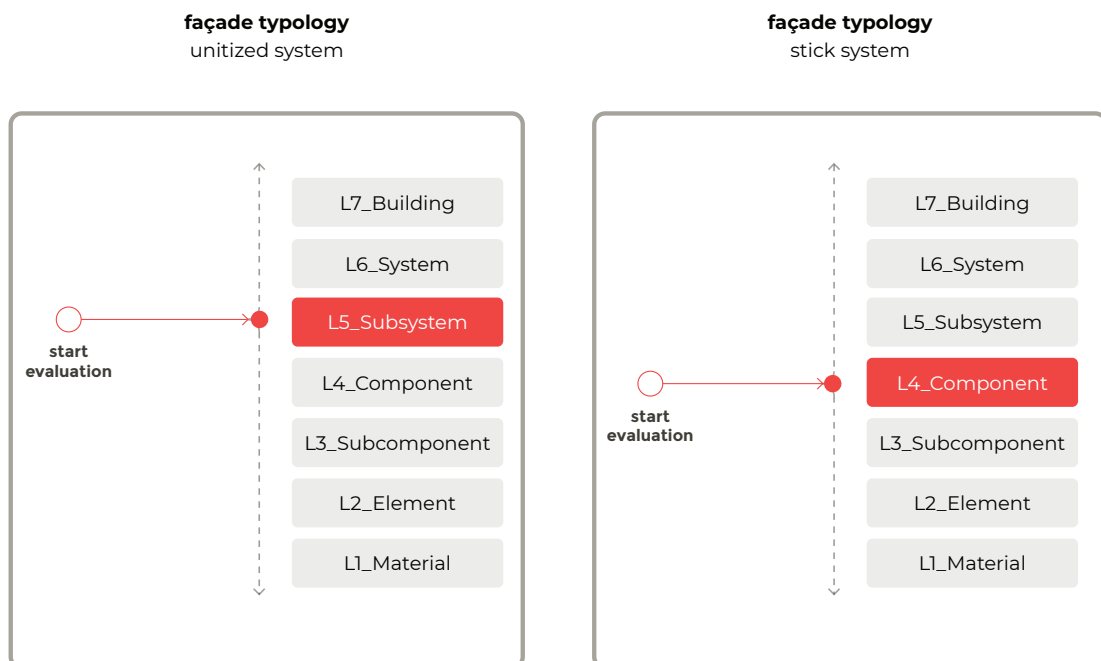
## 6.4 Façade Typology Selection

Before conducting the assessment, it is essential to determine the specific façade typology, which pertains to the clustering of its components across various product levels and their functions. As discussed in Section 4.7, disassembly mapping involves grouping elements into clusters. For this research, focus is primarily on the stick system façade typology. Figure 3.47 illustrates the difference in information access levels based on façade typology.

However, additional typologies may arise as more case studies are conducted. Understanding how these components are structured and their role in the overall function of a building façade is crucial, as it informs the criteria used in subsequent modules. In the case of a stick system, the assessment starts at the element level, and based on the results, access to both higher and lower levels of the databases may be warranted.

### Process

The process of assessing façade typology is straightforward. If the frame elements of the façade extend continuously and bridge multiple floors, it qualifies as a stick system. If the frame elements are separate and assemble into modules, they can be categorized as unitized system. Knowledge on the systems might be required.



**Figure 3.47.** Hierarchy of product levels based on Eekhout, (1997). (Author)

## 6.5 Disassembly Potential

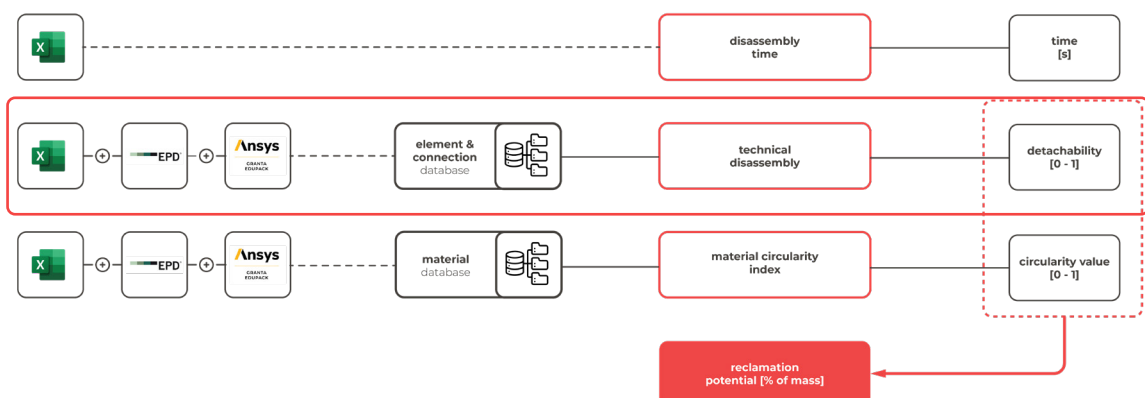
The subsequent assessment module evaluates the technical disassembly of a façade. The design determines if products or elements are physically disassemblable.

### Required Data

To assess the technical disassembly of a façade, thorough building and contextual details are crucial. Detailed component-level drawings are vital to assess technical disassembly. Further data, like the assembly/disassembly sequence, can streamline the evaluation. This data can be in 2D or 3D drawings, or with Building Information Modeling (BIM) advancements, interdependencies might be auto-generated.

### Process

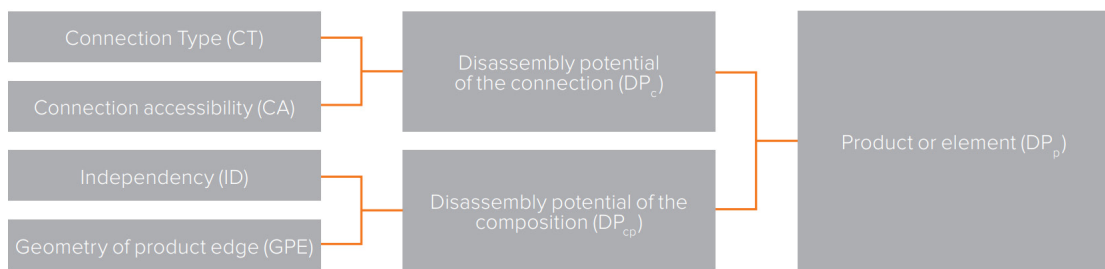
This technical disassembly module primarily assesses the detachability level of the façade under study. For instance, in a stick system, it is critical to ensure the elements can be separated into distinct parts in order to further assess reuse or other potential reclamation routes. Separability between the lower levels, such as subcomponent to element, becomes crucial. Four main criteria are identified: Connection Type (CT), Connection Accessibility (CA), Independency (ID) and Geometry of product edge (GPE) as per Van Vliet, et al. (2021).



**Figure 3.48.** Information Required to assess Technical Disassembly Potential. (Author).

### Calculation Method

Technical disassembly (DPc) shows the ease of taking apart a product, often reflecting the assembly order. It is based on connection type (CT) and accessibility (CA), with the load-bearing connection of an element as standard. Compositional disassembly (DPcp) measures temporary dismantling ease, for instance during renovations, factoring in independency (ID) and product edge geometry (GPE). Figure 00 presents the disassembly potential (DPp) for each element, merging connection (DPc) and composition (DPcp) values, highlighting the ease of disassembly for building elements. Refer to Appendix 10.2 for assessment method.



**Figure 3.49.** Steps to assess technical disassembly potential of elements. Adapted (Van Vliet, et al., 2021).

The formula determining the disassembly potential of a connection n (DPcn) is:

$$DPc_n = \frac{2}{\frac{1}{CT_n} + \frac{1}{CA_n}} \tag{1}$$

Where:

$CT_n$  = type of connection of product or element n;

$CA_n$  = accessibility connection of product or element n.

The formula determining the disassembly potential of a composition n (DPcpn) is:

$$DPcp_n = \frac{2}{\frac{1}{ID_n} + \frac{1}{GPE_n}} \tag{2}$$

Where:

$ID_n$  = independency of product or element n;

$GPE_n$  = product edge geometry of product or element n.

Determining the disassembly potential of the product n or element n (DPpn):

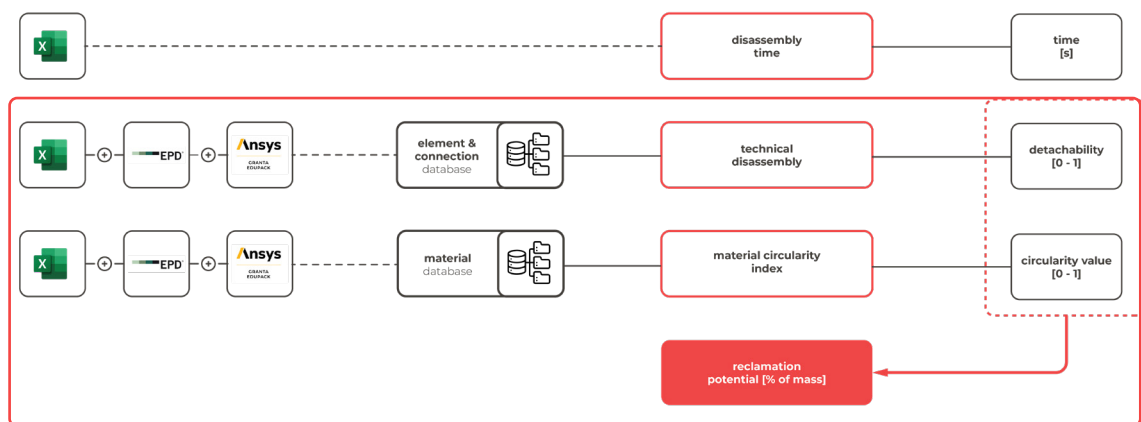
$$DPp_n = \frac{4}{\frac{1}{CT_n} + \frac{1}{CA_n} + \frac{1}{ID_n} + \frac{1}{GPE_n}} \tag{3}$$

## 6.6 Reclamation Potential

The ability to foresee the recoverable materials is crucial when designing, maintaining, renovating, or dismantling façade systems with a circular mindset. Using the PBCI (Cottafava and Ritzen, 2021), reclamation potential can be calculated in terms of percentage (%) of the mass, that can be recovered, mainly for reuse or recycling.

### Required Data

The reclamation potential can be calculated with the Disassembly Potential and the Material Circularity Indicator (MCI). For the latter, the required information is varying depending on the company, since it is necessary to declare an end of life scenario for each material and the amount of recycled/reused material within the original feedstock. This information can be extracted from Environmental Product Declarations (EPD) or the relevant declared Bill of Materials (BOM).



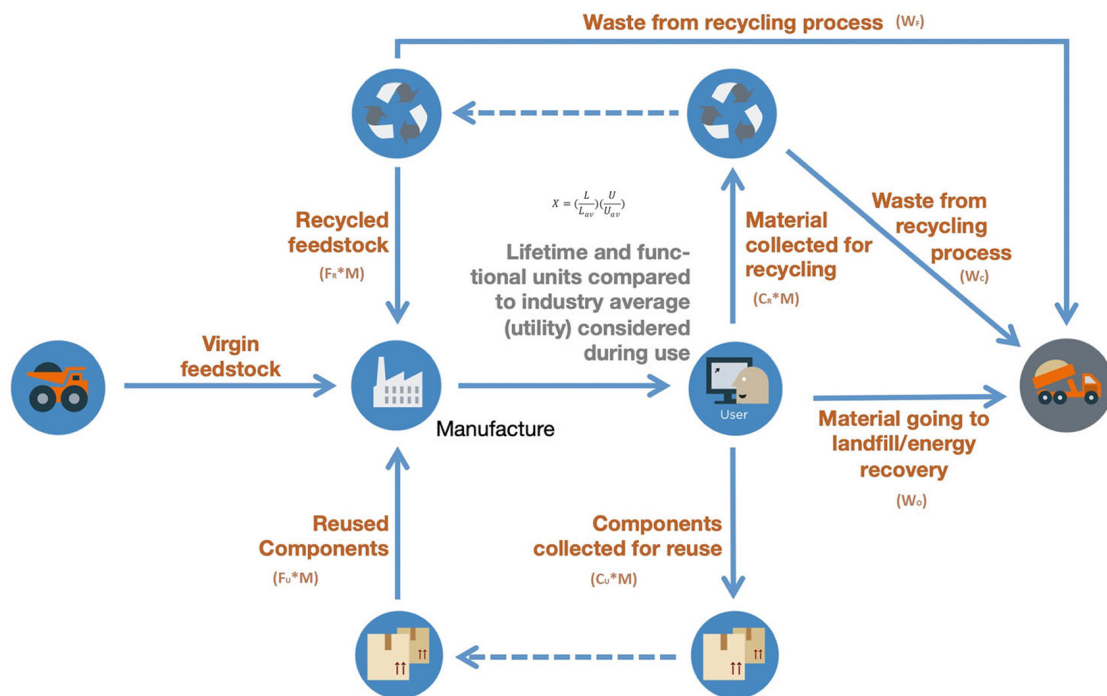
**Figure 3.50.** Required information to assess reclamation potential. (Author).

### Process

The recoverable percentage is determined by applying weights based on Disassembly Potential calculation and Material Circularity Indicator (MCI) calculation, as detailed in Section 6.5. Cottafava & Ritzen (2021) found that actual recoverable percentages, based on design criteria, are lower than the self-declared 100% by reclamation auditors in his research.

### Material Circularity Indicator Calculation

The Material Circularity Indicator (MCI) mentioned in Section 4.2 comprises product circularity during design. It measures the use of recycled material, potential for reuse, lifespan, and efficiency, scoring products between 0 (linear) and 1 (circular). Each façade can then be analyzed based on material weights in a functional unit of one square meter (1m<sup>2</sup>). This is determined using manufacturer data from Environmental Product Declarations (EPD), factoring in recycled and reused material percentages and recycling efficiencies. This method translates diagrams into numerical values, detailed in Appendix 10.1.



**Figure 3.51.** Material flows in MCI calculation (Ellen MacArthur Foundation, 2015)

The MCI is derived through a series of steps depicted in Figure 3.51. Initially, the virgin feedstock ( $V$ ) is determined, followed by calculating the unrecoverable waste ( $W_0$ ) and the utility conversion factor ( $X$ ). The Linear Flow Index is then assessed before finalizing the MCI. Virgin feedstock pertains to the raw material used in production, expressed as  $V = M - (FR + FU)$ , where  $M$  is the product's mass,  $FR$  is the recycled fraction, and  $FU$  is the reused fraction. The unrecoverable waste is given by  $W_0 = M - (CR + CU)$ , with  $CR$  being the product fraction collected for recycling and  $CU$  for reuse. The utility  $X$  considers both product lifetime, compared to industry standards, and its usage intensity. The length component evaluates the product's lifespan against the industry average, while the intensity assesses how fully a product's capacity is utilized.



## Reclamation Potential Calculation

The Reclamation Potential uses the Predictive Building Circularity Indicator (PBCI) as proposed by to compute the recoverable percentage (%) in terms of mass for a façade system as proposed by Cottafava & Ritzen (2021) . This method combines the Material Circularity Indicator (MCI) and the Technical Disassembly to compute the reclamation potential. This is based on the principles of the Buildign Circularity Indicator (BCI), which was reviewed in Section 00, but with the difference that it directly calculates the Disassembly Potential score into the calculation of the MCI.

The suggested approach can be seen in the MCI overview depicted in Fig. 3.51. It forecasts the potential to reclaim materials for recycling, remanufacturing, reuse, and repair, based on design criteria. Essentially, the DfD values are integrated directly into the MCI computation rather than being used as weights for the entire MCI, as seen in the BCI.

From the previous section, the following calculation is derived:

$$LFI_j = \frac{V_j + W_j}{2M_j} = \frac{V_j + f_j \cdot M_j}{2M_j} \quad (1)$$

Where:

$LFI_j$  = Linear Flow Index for product j.

$V_j$  = Virgin material for the product j.

$W_j$  = Amount of unrecoverable waste for product j.

$M_j$  = Total mass of product j.

$f_j$  = Amount of virgin material for the product j.

Consequently,  $f_j$ :

$$f_j = \frac{\sum_{i=1}^n F_{i,j}}{F_d} \quad (2)$$

Where:

$f_j$  = assigned weight for the design criteria i for the product j.

, and  $F_d$ :

$$F_d = \sum_{i=1}^n F_{i,max} = n \text{ and } F_{i,j} \quad (3)$$

Where:

$n$  = is the number of design criteria (in this case  $n = 4$  from disassembly potential)

## 6.7 Disassembly Time

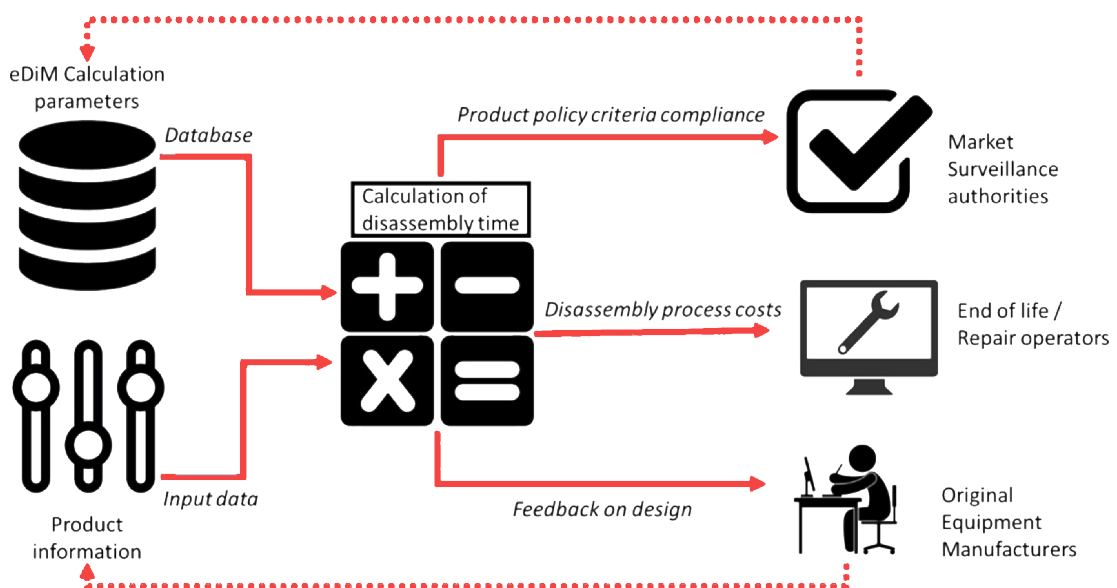
The following assessment module assesses the disassembly time of a façade based on the connections. During the design and construction stages of buildings, it is feasible to oversee the process while keeping these factors in consideration, thereby guaranteeing the potential for disassembly from an economic and effort point of view, when the building reaches the end of its life.

### Required Data

To assess the disassembly time, a list of relevant information can be extracted from an already pre-determined disassembly time database. This database is based on the connection type, which predefines the required time to break a connection apart, as well as tasks and tools to disassemble. This data can be recorded in the Process Database referenced in Section 5.5.

### Process

This module assesses façade disassembly time, utilizing the eDim method (Vanegas et al., 2016) based on the Maynard Operation Sequence Technique (MOST) database, which evaluates disassembly time through predefined actions (Zandin, 2020). The method, detailed in Figure 3.52, assumes tasks are performed by knowledgeable professionals.



**Figure 3.52.** Diagram illustrating Disassembly Time Calculation. Adapted from (Vanegas et al., 2016).

### Calculation Method

The eDiM index measures the effort and time for product disassembly, with the MOST method offering a precise assessment approach (Vanegas et al., 2016). MOST, based on analyzed disassembly times, is apt for tasks with slight motion variations. This study proposes an eDiM calculation method using reference values and categorizing disassembly tasks related to manufacturer product data, emphasizing clear task categorization for objective evaluations. The chart in Figure 3.53 is utilized to compute the eDiM. It displays components, connectors, and disassembly sequences. Columns 1-6 detail components, connectors, and required tools, using reference tables included in Appendix 10.3.

1	2	3	4	5	6	7	8	9	10	11	12	13
Disassembly sequence of components	Disassembly sequence of connectors of components	Number of connectors	Number of product Manipulations	Identifiability (0,1)	Tool Type	Tool Change (s)	Identifying (s)	Manipulation (s)	Positioning (s)	Disconnection (s)	Removing (s)	eDiM (s)
1...												
2...												
...												
...												
...												
N												

|-----Provided-----| |-----Calculated-----|

**Figure 3.53.** Disassembly Time Calculation as proposed by Vanegas et al. (2016).


Using the reference tables from Appendix 10.3, Column 7 determines Tool Change, utilizing Tables 7 and 8. Column 8 calculates connector identification time, with Column 9 indicating product manipulation time, referencing Table 7. Column 10 estimates tool positioning time, while Column 11 determines the fastener disconnection time using Table 8. Column 12 notes the component removal time, and Column 13, the eDiM, is the summation of columns 7-12.

## 6.8 Reuse

### Condition Parameters

This model assesses product quality and condition during planned demolition. The established NEN 2767 (Figure 3.54) serves as a starting point. However, it has subjective elements and lacks clear assessment standards as to what level of detail should be considered. It can be used to assess a façade on various levels, from material to a full façade system.

In (2019), the Façade Service Applicate (FaSa) identified common metal profile defects: surface defects with minimal performance impact, structural defects needing complete replacement, and performance-based defects directly affecting façade performance.



Conditie score	Omschrijving	Toelichting
1	Uitstekend	Incidenteel geringe gebreken.
2	Goed	Incidenteel beginnende veroudering.
3	Redelijk	Plaatselijk zichtbare veroudering. Functievervulling van bouw- en installatiedelen incidenteel niet in gevaar
4	Matig	Functievervulling van bouw- en installatiedelen incidenteel in gevaar.
5	Slecht	De veroudering is onomkeerbaar.
6	Zeer slecht	Technisch rijp voor de sloop

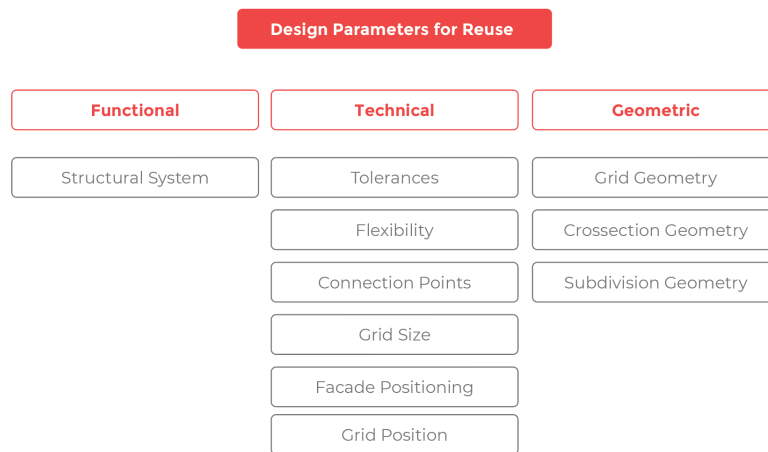
**Figure 3.54.** Overview of physical condition assessment as outlined by the NEN 2767. (Conditie scores NEN 2767, 2021).

### Performance Parameters

Defects affecting façade performance, which require testing, can also be assessed remotely if sufficient monitoring data is available. For instance, long-term temperature sensor data from both interior and exterior sources can reveal thermal performance trends. Historical logs provide insights into issue frequency, influencing potential solutions. Key performance parameters are typically derived from standards that façades must meet for reusability. These values are often established during product testing in the production phase and indicated through CE marking (Platform CB23, 2020).

## Design Parameters

If the façade fulfills all modules, it can be considered for reuse or remanufacturing. In this scenario, design requirements become relevant, determining feasibility. Like any design requirements, these can involve specific quantifiable parameters or more subjective, non-quantifiable aspects. For instance, the floor-to-floor height is a functional requirement, while subdivision geometry depends on aesthetics or building program, making it less quantifiable (Durmisevic, 2006). These criteria, influencing both building and façade design, are detailed and categorized in Figure 3.55, below.



**Figure 3.55.** Overview of parameters which affect the reuse potential of façades based on their initial design. (Author).

Reusing components, especially metals, is recognized but under-documented (Cooper, 2014). Cooper's doctoral work highlights the potential for reusing steel and aluminum without melting, suggesting up to 30% of these metals in products can be reused. He recommends design for disassembly, standardization, product identification, and a reuse assessment protocol.

As illustrated in Figure 00, the façade's geometric properties, like grid geometry and cross-sections, influence its reuse potential in new buildings. Its alignment with nearby components affects installation and air/water tightness. Key aspects include dimensional flexibility, connection points, grid size, and modularity. Standardized measurements or fewer panel types ease reuse. The façade's structural needs, such as additional supports, and compatibility with a new building's system are also pivotal.

## Scenarios for Façade Element Reuse

After evaluating all assessment modules, if a façade qualifies for reuse, there is a subsequent step: determining the best reuse scenario. This decision intertwines with market dynamics, ongoing building projects, available façades for reuse, among other factors requiring more discussion. While not the primary focus of this thesis, research reveals some relevant guidelines:

1. Matching Design to the Existing Façade: This comes into play during a building's preliminary design phase, where adaptability remains. Here, the building molds its design according to the façade set for reuse. For instance, if façade parameters are documented, professionals like architects or façade engineers can evaluate if a façade meets their project's needs. Using the grid size parameter as an example, it directly influences the building's floor-to-floor height to ensure façade compatibility. This is just a glimpse; several other parameters play a role.
2. Matching Existing Façade and New Building: In situations where both the building and the selected façade's designs possess some flexibility, a mutual adaptation scenario emerges. Some aspects of the façade might be fixed, but if it is designed with disassembly in mind, certain parameters might adjust to the building design. Using the grid size example, if the façade's X-axis dimension can be altered and the building's height is pre-determined, the façade can be adjusted to fit the building's requirements.
3. Façade Adaptation to the Building: This scenario arises when a building's design parameters are nearly finalized or when dealing with an existing building. Here, the building's specifications dominate, necessitating a façade that aligns precisely with them. For instance, with a pre-defined grid size, including the floor-to-floor height and possibly internal structures, only a perfectly matching façade is apt for reuse. Thus, the façade adapts to the building's specific needs.



## 6.9 Remanufacturing

In their research, Boorsma et al. (2019) compiled a comprehensive list of 46 guidelines for design aimed at remanufacturing based on their literature review. Additionally, in a separate paper, Boorsma et al. (2018) emphasized that the primary obstacle to implementing re-manufacturing is operational in nature. Therefore a developed a step-by-step workshop to assist manufacturing companies in transitioning into re-manufacturing companies and overcoming these operational challenges was developed.

Remanufacturing, centers on restoring used products to their initial performance level, guaranteeing the same quality as newly manufactured equivalents. Ijomah (2010) proposed that achieving this higher standard of quality and performance demands additional effort. The remanufacturing process initiates with the disassembly of the product, such as the removal of a façade system from a building. Subsequently, it is transported back to the manufacturing facility, where it undergoes further disassembly into individual parts. This signifies the importance of assessing the capacity of a façade design to be disassembled for purposes of remanufacturing. Achieving a high reclamation potential can signify economic incentives for stakeholders such as façade manufacturers and system suppliers.

## 6.10 Recyclability

This module is important when other options for extending the lifecycle of façade products have been ruled out, such as reuse and remanufacturing. The sole criteria to establish is whether the material is recyclable or not.

C2C (2021) defines recycling as the process where a material, once it has fulfilled its original purpose, undergoes mechanical or chemical changes to become a new material, which is then integrated into a different context or application. For instance, the recycling of aluminum from products at the end of their life cycle is already substantial, particularly in sectors like the automotive industry. However, because aluminum products have a lengthy lifespan and a rising demand, there is a limited supply of post-consumer scrap. The volume of aluminum products reaching the end of their life represents an opportunity to create a pool of scrap that can be reintegrated into the circular economy (European Aluminium, 2020).

### Required Data

Based on the previous information, the recyclability of materials can be assessed as shown in Figure 3.56. This information is broadly available on reliable databases such as Granta Edupack.

Recyclability of Materials			
information	attribute	source	database
presence of toxic elements	value	material manufacturer	materials
recyclability	boolean	material manufacturer	materials
material composition	value	material manufacturer	materials

**Figure 3.56.** Table illustrating data required for assessing recyclability on a material level. Adapted from (Author)

### Process

This can be determined using the material database referenced in Section 5.5. If the element is not recyclable, further assessments are conducted to determine if the materials contain toxic contaminants. This necessitates physical inspections. If the element meets these criteria, it is authorized for landfilling or backfilling.

## 6.11 Conclusions

The primary objective behind developing the disassembly assessment framework was to gain a comprehensive understanding of the essential information required to effectively assess how design decisions affect the performance of façade systems at their EoL. A specific context for conducting the assessment was identified, and a detailed breakdown of the sub-stages spanning from Operation to Reverse logistics phases was provided. Each assessment module within the framework were categorized based on the interrelationships among parameters.

1. Disassembly Potential: This allows assessment based on the design criteria of connection.
2. Reclamation Potential: This allows to assess the reclamation potential based on Design for Disassembly criteria by computing point 1 and point 2.
3. Disassembly Time: This allows to factor in time considerations, which have been observed as important in the context of evaluating the feasibility of disassembly from a financial and effort point of view.
4. EoL Assessment Criteria: To assess the different re-life options after disassembly the routes of reclamation of the façade systems can be assessed based on design parameters for reuse, recyclability and remanufacturing principles. However, these will not be evaluated in depth, since it is out of the scope of this research. However it proves important in the context of assessing the reclamation potential and end of life in a hollistic manner.

The identification of necessary information for processing was based on insights gathered from the extensive literature review. The selected criteria can be automatically evaluated if the relevant information is provided in advance. Alternatively, a platform can be used to display the required information and guide assessors sequentially through the decision-making process. Regarding processable and non-processable information, digital drawings and 3D models fall into the processable category, allowing for the extraction of areas, volumes, and quantities. Additional parametrization is sometimes necessary to ensure clarity in how the models are assembled. Alternatively, façade typologies can be pre-categorized to expedite the assessment process. A similar approach can be applied to façade systems with well-defined hierarchy structures.





Source: Author



# 7 Framework Demonstration

7.1	Case Study	89
7.2	Identification of Façade Instances based on Levels	92
7.3	Materials Database	94
7.4	Process Database	97
7.5	Connection Database	98
7.6	Design Phase: Technical Disassembly Potential	99
7.7	Design Phase: Material Circularity Indicator	100
7.8	Design Phase: Reclamation Potential	101
7.9	Design Phase: Disassembly Time	102
7.10	User Output	104
7.11	Next Steps	104
7.12	Conclusions	105

## 7.1 Case Study

The Triodos Bank project façade in Driebergen-Rijsenburg, Netherlands, was selected as a case study to apply the proposed framework (Figure 3.57.). Octatube, a Delft-based company, provided documentation on the project, and is known for its expertise in designing, testing, and constructing complex steel and glass façades and structures. This particular façade, constructed in 2019 by Octatube, was designed considering eventual deconstruction. Every component and material is cataloged in a Madaster material passport for potential reuse (Octatube, 2018).



**Figure 3.57.** (left) Triodos Bank Façade in Driebergen-Rijsenburg, Netherlands. (right) Typical Façade Detail of Triodos Bank analyzed in this research. Adapted from (Octatube, 2018).

Triodos Bank, Octatube, and EDGE Technologies are currently considering a circular strategy for the façade, with one option being its purchase by a consortium of Triodos Bank and Octatube (Octatube, 2018). In 2023, a section of the façade was disassembled by an Octatube specialist, who provided feedback on the process and the reclamation potential of the materials for the purpose of this research. Appendix 10.6, compiles the received information from Octatube for this project.

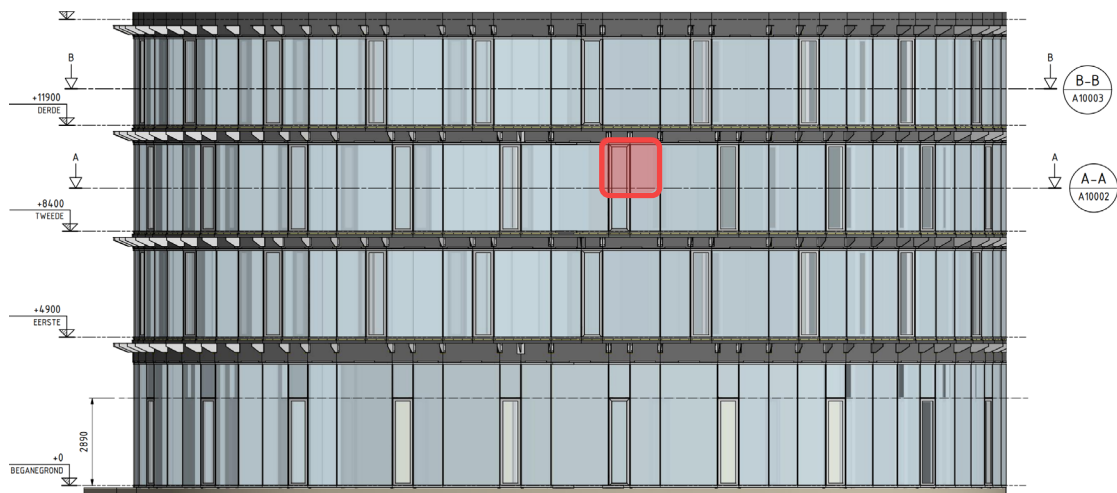
### Assumptions and Limitations

Due to time constraints and limited data availability, the research set specific boundary conditions. The main objective is to demonstrate the framework's utility for reclamation potential, not an exhaustive analysis of every façade design detail. Therefore, components like movable or motorized parts and those with different supply chains were omitted. The analysis centers on the typical design features of the system, using available data. Missing information was supplemented with industry standards and relevant prior research.



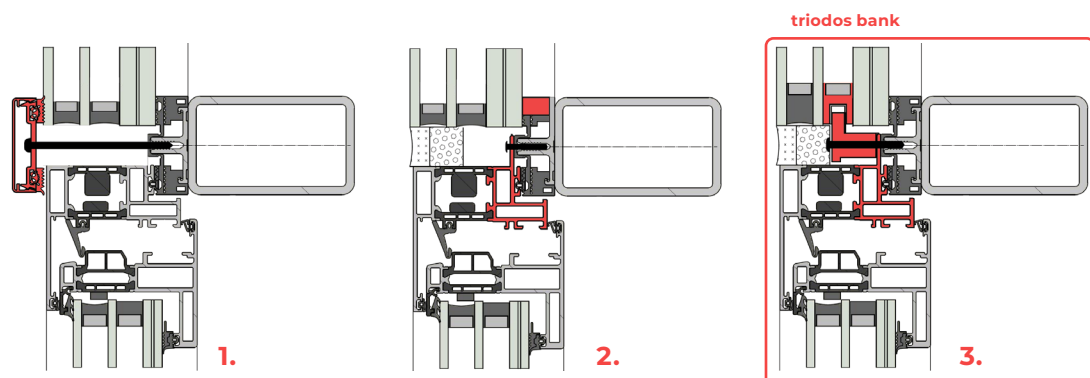
## Stick System Scenarios

The Triodos Bank Project glass façade uses various connection types, with this study focusing on the standard glazing connection in the stick system. While prevalent throughout the project, a deeper investigation could cover all façade details, like ground, wall, and roof connections to represent a more holistic view of the system. Figure 3.58 displays a 1 m<sup>2</sup> standard detail from the building façade, serving as a consistent unit for analysis.



**Figure 3.58.** Triodos Bank Elevation. Analysed system highlighted red. Adapted from (Octatube, 2018).

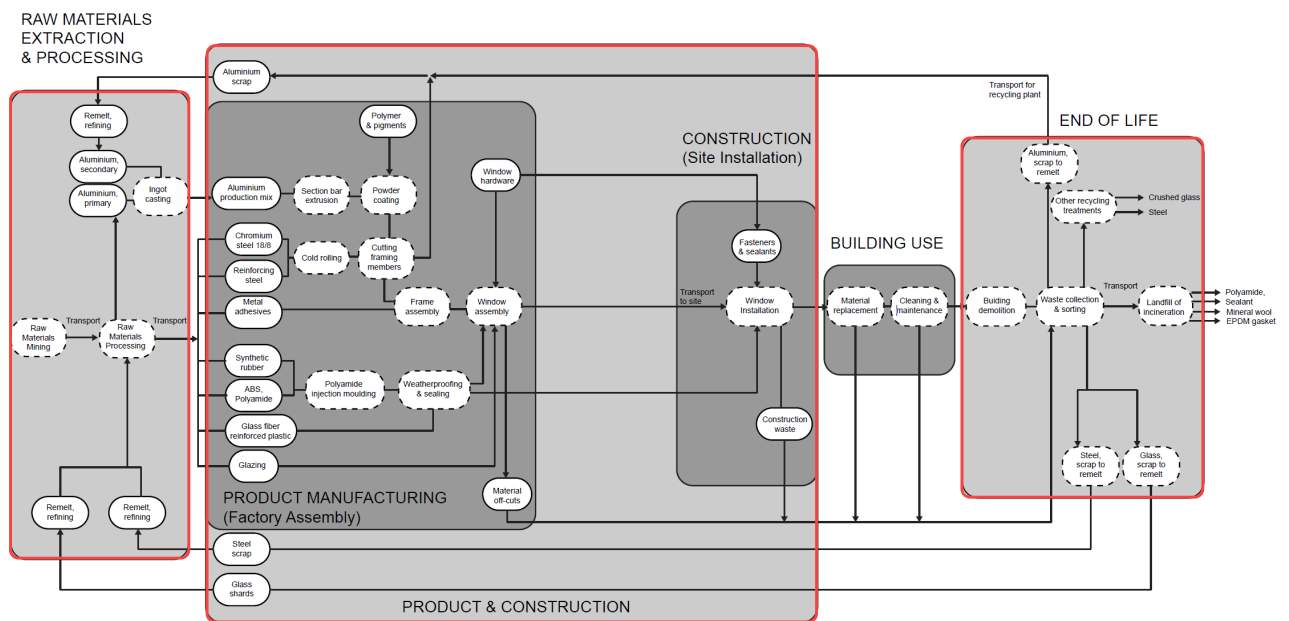
The first system represents a stick system with a clamped connection type to support the fixed glazing and the operable window (1), the second system is composed of a structural silicone and a screw connection for the fixed glazing and the operable window, respectively. The third system (3) represents a structural fixing with a toggle system for the fixed glazing and a screw fixing for the operable window. The latter represents the original design for the Triodos Bank, as proposed by Octatube.



**Figure 3.59.** Analysed stick systems details, main connection differences highlighted in red. Adapted from (Octatube, 2018).

## Material Flows

Carlisle, Friedlander, and Faircloth (2015) reviewed the life cycle of aluminum frames and glazing. Specialized contractors handle façade dismantling, cutting profiles into smaller pieces for recycling. Generally, all materials are removed, except for mineral wool, which lacks recycling options. Glazing is separated for collection, and the rest is sold as scrap metal (Gamerschlag, 2020).



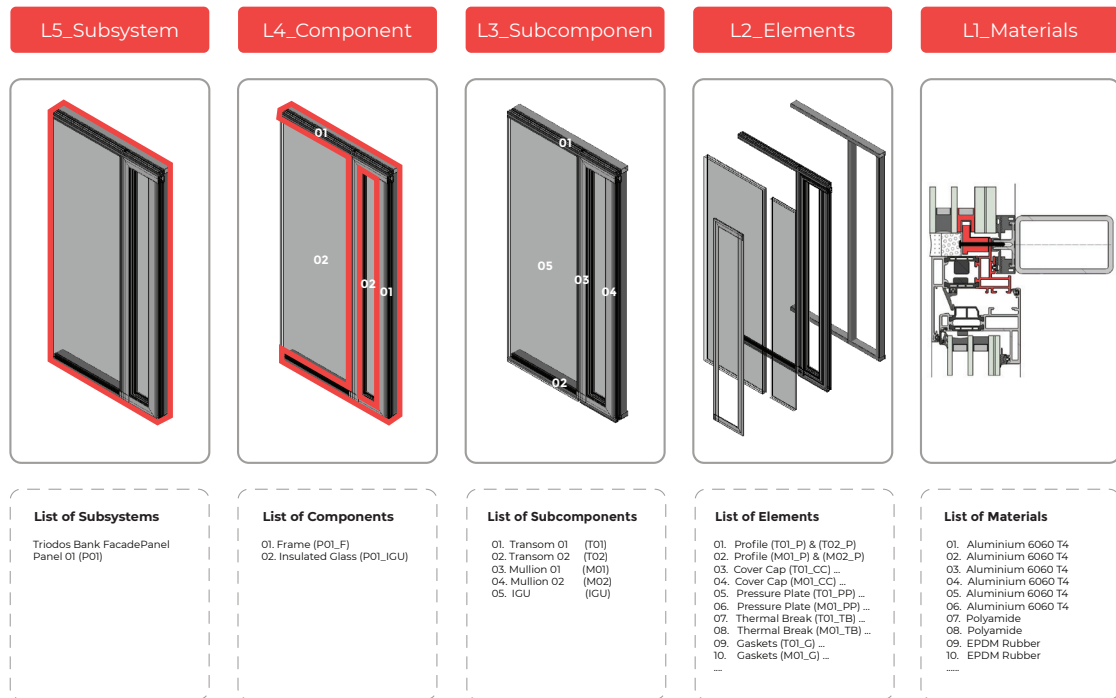
**Figure 3.60.** Lifecycle stages of aluminium and glass system. (Carlisle, Friedlander, & Faircloth, 2015).

Appendix 10.6 lists the information received from Octatube regarding the materials used in the facade system. Information regarding the material composition of each element was supplied by the Material Manufacturers in EPD format (Appendix 10.6). Missing data was supplemented with relevant research on the topic of glass and aluminium recycling percentages (Hartwell et al., 2022; European Aluminium Association, 2004). The functional unit (FU) is 1 m<sup>2</sup>.

1. Aluminium Profiles: Powdercoated aluminium profiles from Schueco have a recycled content of 49%, with 89% going to recycling at EoL.
2. Aluminium Frames: Powdercoated aluminium profiles from Schueco have a recycled content of 49%, with 89% going to recycling at EoL.
3. Glazing: Float Glass from Euroglass has a recycled content of 1%, with 60% going to landfill at EoL due to coatings and adhesives.
4. Weather Gaskets: EPDM Rubber has 0% recycled content, 100% landfill.
5. Thermal Breaks: Polyamide Technoform has 0% recycled content, 100% landfill.
6. Silicone Sealant: Sika has 0% recycled content, 100% goes to landfill or incineration.

## 7.2 Identification of Façade Instances based on Levels

As discussed in Section 5.3, the façade system can be evaluated based on the different hierarchy levels as proposed by Eekhout (1997). First it is necessary to categorize all parts of the façade system into the separate levels as shown below.



**Figure 3.61.** Identification of façade parts into distinct levels of a typical aluminium stick system, based on Raynears CW 60. (Author)

### Level (L7): Building

The building level comprises the entire construction system, of which the façade system is part of. Information that can be used is location of the building, transport distances, environmental conditions of the area, etc. For the scope of this research, the building level will not be analyzed.

### Level (L6): System

System level refers to which part within the entirety of the building is being assessed. For instance, system could be the north façade or the south façade. This level is not relevant in the context of this research, but could be added in further research.

## 7.3 Materials Database

### Level (L1): Materials

Octatube supplies the required information for the material composition of the elements. This Information can additionally be sourced from the System Manufacturers in form of EPD's. Appendix 10.6 illustrates the data collection for the Triodos Bank Project. It is important to note that the environmental data such as recycled content and reused content is important in order to process further calculations related to the Material Circularity Indicator (MCI) as shown in Figure 3.62. Figure 3.62. illustrates the percentage of different materials contained in the proposed scenarios from Section 7.1.

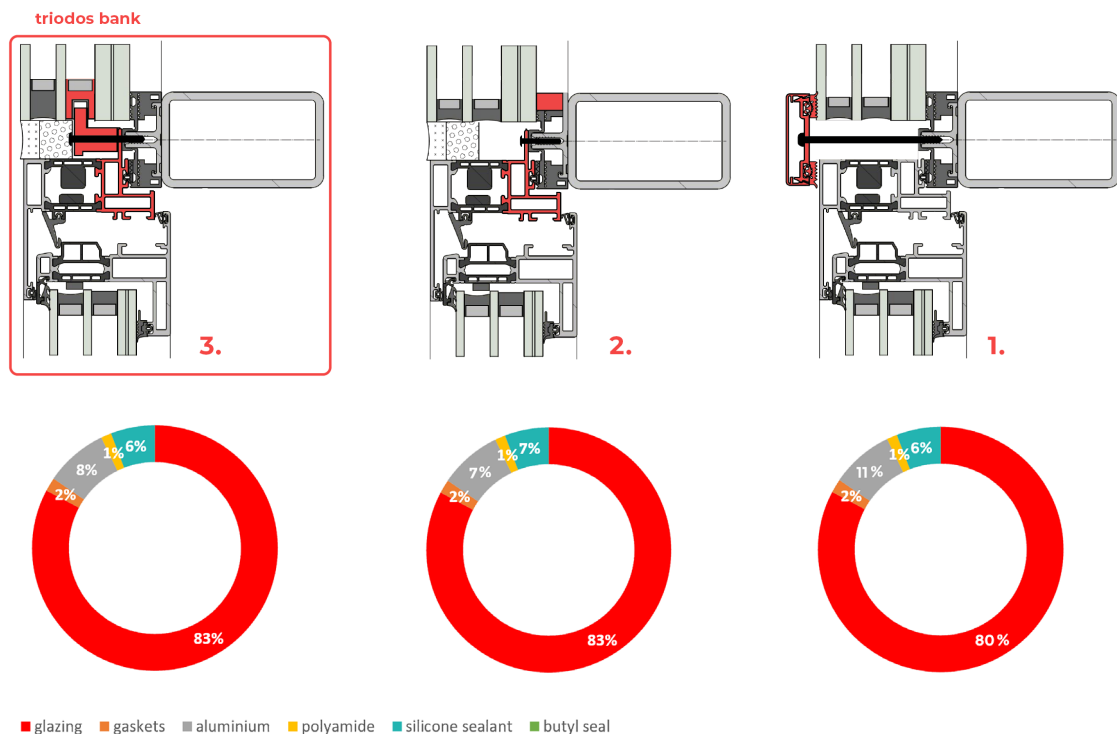


Figure 3.62. Material contents of systems under analysis. (Author).

aluminium 6060 T60				
data category	property	value	unit	type
physical	density	2700	kg/m3	value
	price	1,86	EUR	currency
environmental	recycle	yes	unitless	boolean
	downcycle	yes	unitless	boolean
	energy recovery	no	unitless	boolean
	landfill	yes	unitless	boolean
	recycled content	49	%	value
	reused content	0	%	value

Figure 3.63. Example material database aluminium 6060 (L1) Material Data. (Author).

**Level (L5): Subsystem**

The subsystem is identified as a composition of components, which carry the façade functions (Eekhout, 1997). Using the original name of the façade product, the subsystem level can be categorized. Each panel in an existing design or in the process of being design is named with an ID to be able to identify it. In this case it is identified as P01 for Panel 01.

**Level (L4): Component**

Layered or framed assembly of component functions, which are integrated of subcomponents. For instance, when frames are connected with connectors, they collectively form a component (Eekhout, 1997). For identification purposes, the ID of the components could be expressed as P01\_F (which relates to Panel 01 Frame). Glazing could be identified as P01\_IGU (which relates to Panel 01 IGU).

**Level (L3): Subcomponent**

At the subcomponent level, frames are individually tailored as well as the glazing unit. Vertical Mullions are denoted as M01, M02, etc. Horizontal Transoms are denoted as T01, T02, etc. It is crucial to document each of these elements as a unique instance to identify potential problems in the disassembly process. A Insulated Glazing Unit is still regarded as one unit.

**Level (L2): Element**

Elements are all the individual parts that compose the assembly of the different subcomponents. For instance all profiles, thermal breaks, gaskets, or any other instance is computed. (Eekhout, 1997). The Elements can relate to the Subcomponent by the ID, when identifying for instance T01\_P (Transom 01 Profile) or T01\_TB (Transom 01 Thermal Break)

**Level (L1): Materials**

The raw material level provides details about the material properties in its original state. This level relates directly to the Element Level since the materials are processed to become elements in the façade assembly.

## Level (L2): Element

Information about the used elements in the façade could be extracted manually from a Bill of Materials (BoM). Octatube provides a BoM for Triodos Bank. If the system is linked to a Building Information Model (BIM), information could be extracted automatically. Additional information such as the design data can be accessed at this level as well as the associated connections. Figure 3.64 and Figure 3.65 show the information corresponding to 1 m<sup>2</sup> based on the BoM and EPD for the façade system provided by Octatube (Appendix 10.6).

ID: M01_CC				
data category	property	value	unit	type
general	name	cover cap	unitless	text
	length	1000	mm	value
physical	width	60	mm	value
	depth	180	mm	value
	mass	3.78	kg	value
technical	declared lifespan	50	years	value
	industry lifespan	75	years	value
design	drawing	link drawing	unitless	graphic
	model	link model	unitless	graphic
database link	connection database	snap fit	unitless	link to connection ID
	material database	aluminium 6060	unitless	link to material ID
	disassembly process database	snap fit	unitless	link to disassembly ID

Figure 3.64. Level 02: Mullion 01 Cover Cap (M01\_CC), with data from Manufacturer EPD. (Author)

ID: M01_PP				
data category	property	value	unit	type
general	name	mullion 01	unitless	text
physical	length	1000	mm	value
	width	60	mm	value
	depth	268	mm	value
	mass	3.78	kg	value
technical	declared lifespan	50	years	value
	industry lifespan	75	years	value
design	drawing	link drawing	unitless	graphic
	model	link model	unitless	graphic
database link	connection database	screw	unitless	link to connection ID
	material database	aluminium 6060	unitless	link to material ID
	process database	screw	unitless	link to disassembly ID

Figure 3.65. Level 02: Mullion 01 Pressure Plate (M01\_PP) with data from Manufacturer EPD. (Author)



## 7.4 Process Database

The Material Process database can contain information pertinent to assessing the façade, such as its CO2 footprint from production. Currently, numerous databases already offer such information such as EcolInvent and Oekobaudat. Information can also be substracted from the EPD supplied by the Product Manufacturers. The key focus here is not on determining which database is most suitable for façade assessment.

Additionally, this framework proposes the storage of information regarding disassembly process. This could allow for informed decision making at EoL, but also, in a scenario where more data becomes available and stored, it can contribute to models which could predict disassembly processes in the future.

### Disassembly Process Database

The disassembly process database records necessary steps for disassembly tasks, facilitating time calculations via the Disassembly Time calculation method explained in previously. This method includes five specific disassembly tasks: tool change, identification, manipulation, positioning, and removal, as detailed in Appendix 10.3. Figure 3.66 shows how disassembly steps could be highlighted.

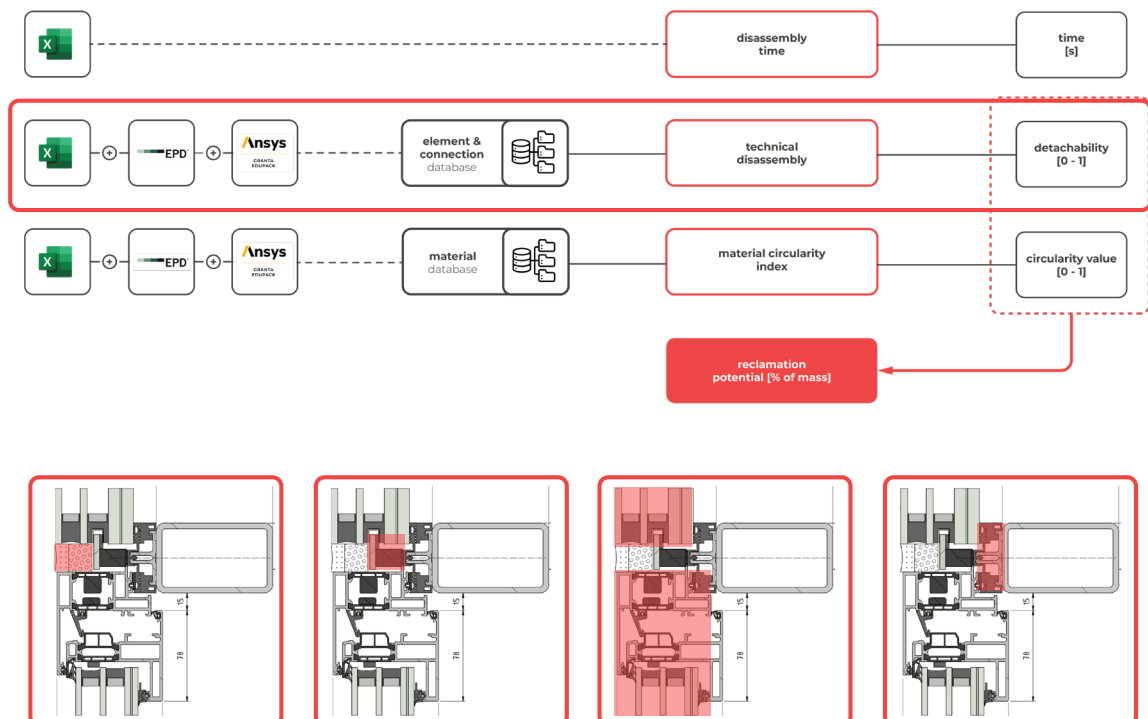
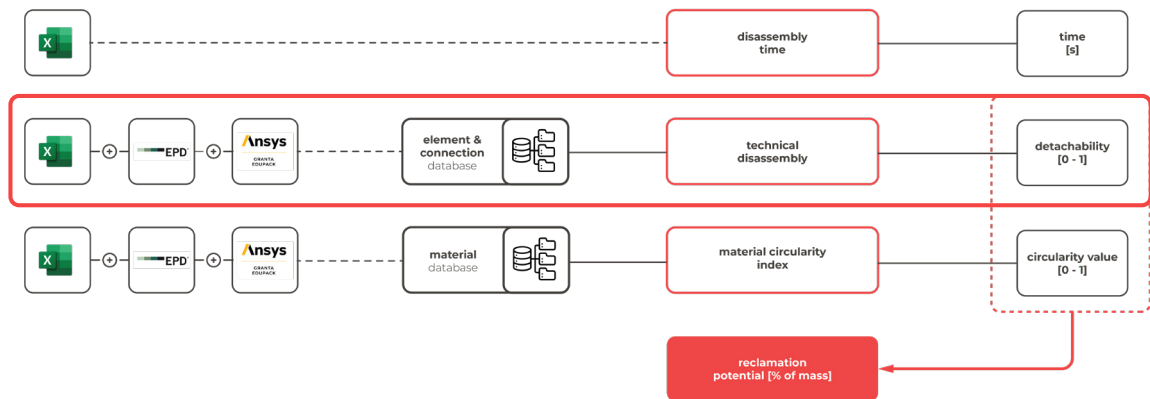


Figure 3.66. Steps to disassemble the facade detail in order. (Author)

## 7.5 Connection Database

The connection database includes details such as the estimated disassembly time for each type of connection, determined using the Disassembly Time Calculation method previously reviewed. It encompasses necessary tools, actions for disassembly, and disassembly potential ratings. Thus, when a specific component is connected to another with a snap-fit, the relevant details can be retrieved using the 'snap-fit' identifier in the database. These details are crucial inputs for calculating Disassembly Potential and Disassembly Time, as demonstrated in Figure 3.67.

As more assessments of different facade systems are conducted, this database could evolve into a tool that automatically evaluates designs based on the connections used. However, current literature reviews indicate a lack of comprehensive data on these processes. For this study, the Connection Database was manually compiled using Excel sheets.



**Connection: Snap-Fit**

information	attribute	value	unit
disassembly time	value	18	seconds
tools	multi option	n/a	hands
connection type	multio option	dry connection	n/a
disassembly potential	value	1	n/a

**Figure 3.67.** Information stored in the connection database: Snap-fit. (Author)

## 7.6 Disassembly Potential

### Access to Database

1. L2\_ Element Information: Design Data (Section 7.3.) is needed for the detail drawings, including vertical and horizontal sections of the system as illustrated in Figure 3.68 of the Triodos Bank.
2. Connection Database: To extract connection types and sequences.

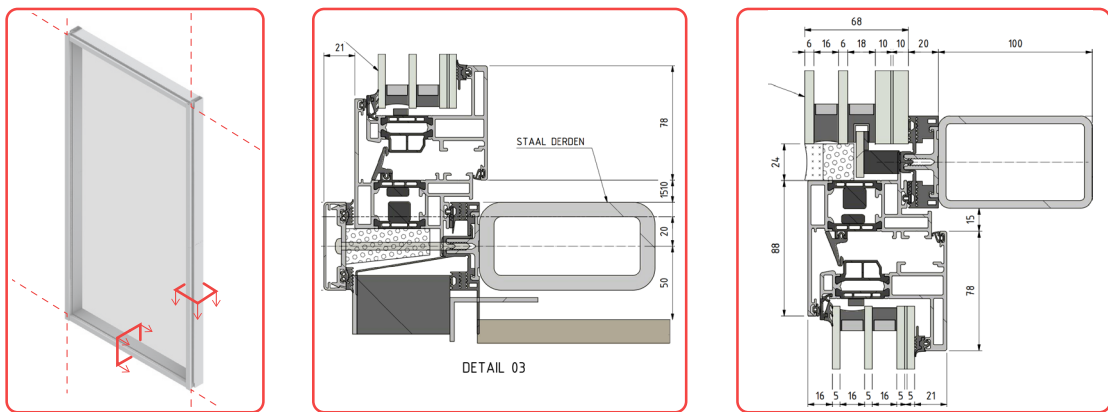


Figure 3.68. Vertical (center) and horizontal (right) detail drawings. Adapted from (Octatube, 2018).

### Disassembly Potential Calculation Process

The Disassembly Potential (DPp) for elements in a 1m<sup>2</sup> section of the Triodos Bank facade was evaluated (see Appendix 10.11). Scores range from 1 (best) to 0 (worst). Elements like the transom profile, gaskets, and toggle scored high due to their screw fixings and snap fits (CT). They are also damage-free accessible (CA). However, elements with adhesives scored lower as anticipated (silicone seals).

product disassembly (DPp)

element ID	element name	material	CT	CA	ID	GPE	DPp
T01_S	transom silicone seal	silicone	0,1	0,1	1	1	0,2
T01_TA	transom toggle	aluminium 6060	0,8	0,8	1	0,4	0,7
T01_G	transom gasket	aluminium 6060	0,8	0,8	1	0,4	0,7
T01_P	transom profile	aluminium 6060	0,8	0,8	1	0,4	0,7
IGU	insulated glass unit	mixed	0,8	0,8	1	0,4	0,7
IGU_LG	laminated glass	float glass + pvb	0,1	0,4	0,1	0,1	0,1
IGU_BS	butyl seal	isobutylene	0,1	0,1	0,1	0,1	0,1
IGU_SP	thermobar spacer	aluminium	0,1	0,4	0,1	0,1	0,1
IGU_TC	tempered glass	low-e glass	0,1	0,4	0,1	0,1	0,1
IGU_SP	thermobar spacer	aluminium	0,1	0,4	0,1	0,1	0,1
IGU_TC	tempered glass	low-e glass	0,1	0,4	0,1	0,1	0,1
IGU_SS	silicone seal	silicone	0,1	0,1	0,1	0,1	0,1

Figure 3.69. Individual elements technical disassembly potential. (Author)

## 7.7 Reclamation Potential

### Access to Database

1. L1\_Materials: Environmental Product Declarations of Elements (Appendix 00). Industry standards for information gaps (Hartwell. et al, 2023).
2. L2\_Elements: For information about mass of the individual elements.

### Material Circularity Calculation Process

The Material Circularity Indicator (MCI) rates material flows in the context of circularity. A score of 1 is ideal. For Triodos Bank's facade, EPDM gaskets and sealants aren't recycled, often going to landfills. Aluminum profiles have a 0.7 score due to shorter lifespan (Figure 3.70). The insulating glass scores 0.5, hindered by coatings and adhesives which make recycling technologically challenging.

element ID	element name	material	declared lifespan (L)	industry (Lav)	factor (X)	utility factor F(x)
T01_S	transom silicone seal	silicone	25	25	1,0	0,9
T01_TA	transom toggle	aluminium 6060	60	75	0,8	1,1
T01_G	transom gasket	aluminium 6060	25	25	1,0	0,9
T01_P	transom profile	aluminium 6060	60	75	0,8	1,1
IGU_LG	laminated glass	float glass + pvb	30	30	1,0	0,9
IGU_BS	butyl seal	isobutylene	30	30	1,0	0,9
IGU_SP	thermobar spacer	aluminium	30	30	1,0	0,9
IGU_TG	tempered glass	low-e glass	30	30	1,0	0,9
IGU_SP	thermobar spacer	aluminium	30	30	1,0	0,9
IGU_TG	tempered glass	low-e glass	30	30	1,0	0,9
IGU_SS	silicone seal	silicone	25	25	1,0	0,9

Figure 3.70. Utility Factor F(x) of the materials in the typical facade detail of the Triodos Bank. (Author)

#### material circularity (MCI)

element ID	element name	material	mass (M)	linear flow index (LFI)	utility factor F(x)	MCI
T01_S	transom silicone seal	silicone	1,05	1,0	0,9	0,1
T01_TA	transom toggle	aluminium 6060	0,30	0,3	1,1	0,7
T01_G	transom gasket	aluminium 6060	1,26	1,0	0,9	0,1
T01_P	transom profile	aluminium 6060	0,60	0,3	1,1	0,7
IGU_LG	laminated glass	float glass + pvb	32,40	0,6	0,9	0,5
IGU_BS	butyl seal	isobutylene	0,01	1,0	0,9	0,1
IGU_SP	thermobar spacer	aluminium	0,40	0,3	0,9	0,8
IGU_TG	tempered glass	low-e glass	12,70	0,6	0,9	0,5
IGU_SP	thermobar spacer	aluminium	0,40	0,3	0,9	0,8
IGU_TG	tempered glass	low-e glass	12,70	0,6	0,9	0,5
IGU_SS	silicone seal	silicone	2,05	1,0	0,9	0,1

Figure 3.71. MCI for each Element in the analyzed façade system. (Author)

## Reclamation Potential

1. L1\_Materials: Environmental Product Declarations of Elements (Appendix 10.9). Industry standards for information gaps (Hartwell. et al, 2023).
2. L2\_Elements: For information about mass of the individual elements.
3. Connection Database: To extract Disassembly Potential of the system.

## Reclamation Potential Calculation Process

The Reclamation Potential, as detailed in Section following the PBCI model, combines the disassembly potential (DP) of each element with the Linear Flow Index (LFI) in the MCI calculation. This predicts the percentage (%) of materials in terms of mass that can be reclaimed for reuse or recycling as seen in Figure 3.72, based on the design criteria of the system under analysis (Cottafava et al., 2021).

reclamation potential

element ID	element name	material	mass (M)	virgin feedstock (V)	unrecoverable (W)	reclamation potential	ff
T01_S	transom silicone seal	silicone	1,05	1,05	1,05	18%	0,2
T01_TA	transom toggle	aluminium 6060	0,30	0,15	0,01	67%	0,7
T01_G	transom gasket	aluminium 6060	1,26	1,26	1,26	67%	0,7
T01_P	transom profile	aluminium 6060	0,60	0,31	0,03	67%	0,7
IGU	insulated glass unit	mixed	60,66	54,49	19,76	90%	0,9
IGU_LG	laminated glass	float glass + pvb	32,4	29,16	9,90	12%	0,1
IGU_BS	butyl seal	isobutylene	0,01	0,01	0,01	10%	0,1
IGU_SP	thermobar spacer	aluminium	0,4	0,204	0,02	12%	0,1
IGU_TG	tempered glass	low-e glass	12,7	11,43	3,88	12%	0,1
IGU_SP	thermobar spacer	aluminium	0,4	0,204	0,02	12%	0,1
IGU_TG	tempered glass	low-e glass	12,7	11,43	3,88	12%	0,1
IGU_SS	silicone seal	silicone	2,05	2,05	2,05	10%	0,1

**Figure 3.72.** Calculating the reclamation potential in terms of percentage for each material. (Author)

Taking into account aluminum recycling processes and material loss, as well as disassembly potential, the analysis predicts a 67% material reclamation rate for the aluminum profile. This is likely because the profile's design and connection methods, such as screws and connection geometry, may make disassembly more time-intensive, leading to a potentially destructive process. Examining the individual elements of the Insulated Glass Unit (IGU) reveals low material scores, primarily due to the use of adhesives in assembly, which necessitates a destructive disassembly process. However, when viewed as an entire system, the IGU's reclamation potential in terms of design is much higher, at 90%. Yet, it is important to recognize that these figures are subjective, as they stem from a semi-qualitative assessment of disassembly potential.

## 7.8 Disassembly Time

### Access to Database

1. Connection Database: This allows to introduce tasks, tools and materials used in the process of disassembling, thus leading to the calculation of Disassembly Time.
2. Disassembly Process Database: Information stored about disassembly tasks, sequence and tools for each connection type.

### Disassembly of Insulated Glass Units

To calculate disassembly time. Disassembly times from a façade teardown project conducted by Arup & Frener Reifer (2019) for a typical DGU are referred to (Appendix 10.4). A site visit to GSF Glasgroep (Figure 3.73) was conducted and highlights the importance of calculating disassembly times for enhanced material reclamation, implying financial considerations for reuse or other re-life scenario. GSF Glasgroep pioneered a circular production method for Insulated Glass Units (IGU), through an innovative process known as isoMAX Circu-therm (GSF Glasgroep, 2023). The times to disassemble de DGU, as per the site visit, cannot be compared, since the company processes the units in a distinct manner, using uncommon tools, which result in a material loss on both glazing and spacer. However, the process of removing the spacer from the glass was observed as time consuming, being the main barrier for disassembly. The only way to remove the DGU spacer is by cutting through it with uncommon tools. The result is, a glass pane which has to be cut at the borders in order to be reused in a new DGU.



**Figure 3.73.** Glass separation, material loss due sealing compound (left). Glass sent to landfill (right). (Images by Author).



## Disassembly of Triodos Bank Facade Panel

To enhance the calculation approach, an interview was conducted with an Octatube employee who disassembled a facade panel from Triodos Bank in 2023. Detailed in Appendix 10.5, this discussion provided insights into the disassembly process, aligning with the informational structure of preceding chapters. Additional detailed drawings highlighted potential improvements. By comparing the calculations with the actual disassembly time at the company, a clearer picture can be gained. However, since the system was not disassembled from the original building, direct comparisons about tools and durations on-site are challenging. The panel's disassembly at Octatube was part of a clean-up task.



**Figure 3.74.** (left) Triodos Bank Mockup: Disassembly of Gaskets. (right) Screws used in window-frame assembly. (Octatube, 2018).

Drawing from the interview and aligning with the Disassembly Potential Model by the Dutch Green Building Council (2021) referenced in Section 4.3, findings include:

1. Expertise: It took two skilled workers to disassemble the facade.
2. Safety: Safety precautions were taken on site of the disassembly by using safety shoes and protective glasses.
3. Disassembly Time: Frame took 1 hour, 20 minutes to remove glass pane with crane and suction cups, gaskets were pulled out in 1-2 minutes per gasket.
4. Tools: Common facade industry tools were used, such as impact driver for the bolts in the anchoring, utility knives for the sealants, hands for the gaskets and screwdriver to open toggle system and remove any screws.
5. Residual Value: The Octatube employee estimated that everything can be reused except the gaskets and the sealing material.
6. Main challenges: Removing adhesive sealant in the frame system.



**Figure 3.75.** Tools used in the disassembly of the Triodos Bank Facade Mock-up. (from left to right): hands, impact driver, screwdriver, utility knife, mobile glass lifting machine. (Alamy, 2023)

### Disassembly Time Calculation Process

To estimate disassembly time, estimations from the disassembly report by Arup & Freiner (2019) (Appendix 10.3) were used and then compared with the time projected by an Octatube employee (Appendix 10.5). It is crucial to understand that these calculations serve as approximations due to the limited data on specific tasks and facade disassembly times.

According to Arup & Freiner's research, disassembling a Double Glazed Unit (DGU) takes 1408 seconds, and a typical stick system framing takes 2448 seconds. Employing the method from Section 6.7, known as the eDiM method, the calculated DGU disassembly time was 1233 seconds, showing a 14% difference. However, the eDiM method typically applies to objects weighing 4kg, while the DGU in question weighs 51kg. To accommodate this discrepancy, the calculation was adjusted by scaling the time estimate in proportion to the weight. The nature of this process underlines the potential benefit of a façade-specific disassembly time database to streamline calculations based on types of connections.

Name	Material	connection ID	connectors	manipulations	visibility (0,1)	tool type	change (s)	identify (s)	manipulate (s)	position (s)	disconnect (s)	remove (s)	eDiM (s)
laminated glass	laminated	glue <20 N	4	1	visible	cut	1,4	0,0	1,8	5,6	8,8	1,4	17,6
butyl seal	isobutylene	glue <20 N	4	1	hidden	cut	1,4	3,6	1,8	5,6	8,8	1,4	21,2
hermobar space	aluminium	glue <20 N	4	1	hidden	hand	1,4	3,6	1,8	5,6	8,8	1,4	21,2
silicone seal	silicone	glue <20 N	4	1	visible	cut	1,4	0,0	1,8	5,6	8,8	1,4	17,6
tempered glass	low-e glass	glue <20 N	4	1	visible	cut	1,4	0,0	1,8	5,6	8,8	1,4	17,6
													<b>1233</b>
													(Arup & Freiner Reifer, 2019) <b>1408</b>
													<b>difference 14,80%</b>

**Figure 3.76.** Calculated eDiM for the façade under analysis. (Author)

## 7.9 Comparison Scenarios

In order to showcase the utility of the workflow, three systems (Figure 3.77) outlined in the case study, were benchmarked. Scenario 01 and Scenario 02 were constructed by the Author. The following figures demonstrate the performance in terms of the Disassembly Assessment framework.

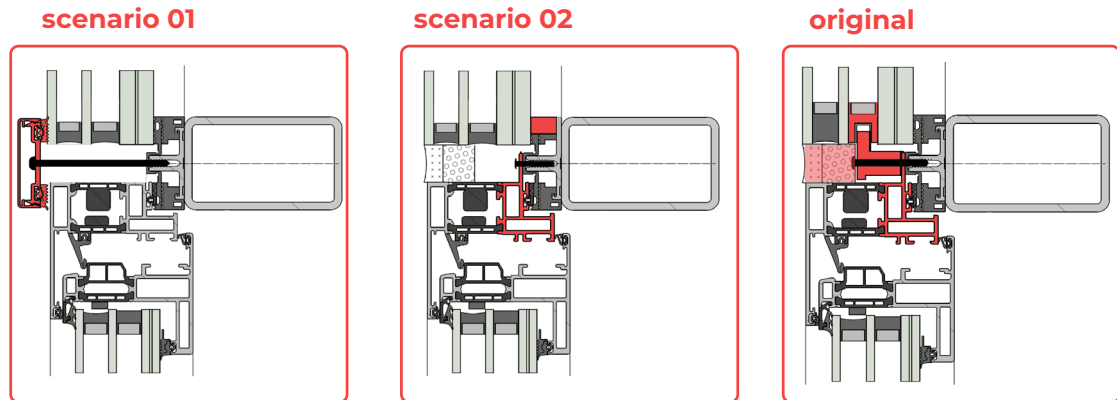


Figure 3.77. Facade Connection Scenarios under Analysis. Adapted from (Octatube, 2018).

### Benchmark Results: Scenario 01

Scenario 01 shows a typical aluminium stick system, where the glazing is held by a clamped connection. After analyzing the system in Figure 3.78, it is evident that a clamped connection performs well in terms of reclamation potential, material circularity and disassembly potential. Additionally, disassembly times are reduced.

1. Aesthetic Implications: If aesthetic implications are to be taken into account, probably this choice would not be suitable for the overall architecture of the facade. Perhaps, design choices can influence the choice of connection as well. With this system, the aluminium profile would be visible throughout the entire facade.

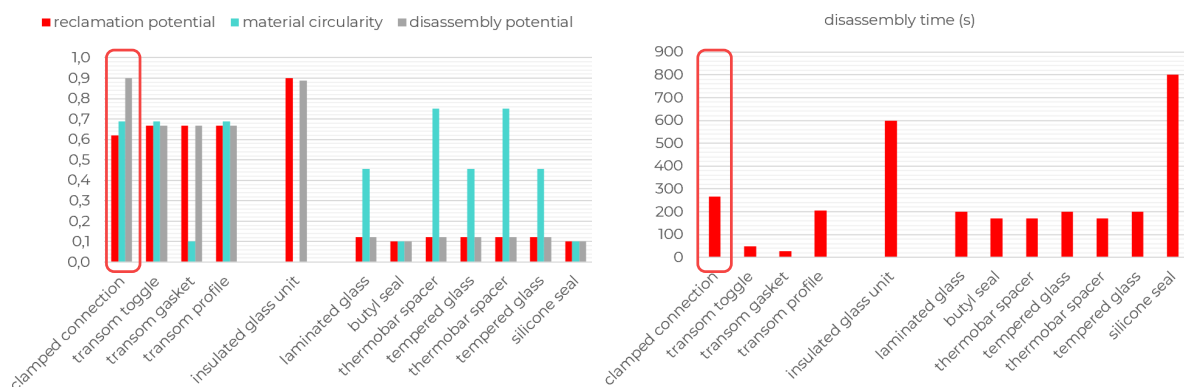


Figure 3.78. Benchmark results for Scenario 01. (Author).

### Benchmark Results: Scenario 02

Scenario 02 represents a structurally glazed system, where the glazing is supported by structural silicone, as illustrated in Figure 3.79. This system allows for less visible aluminium in the facade, since the glazing is supported by the silicone, thus eliminating the clamped connection. However, in terms of performance regarding reclamation potential, this system performs lower than the clamped system, due to the adhesive nature of the connection. Additionally, disassembly times could be impacted significantly as seen in Figure 3.79.

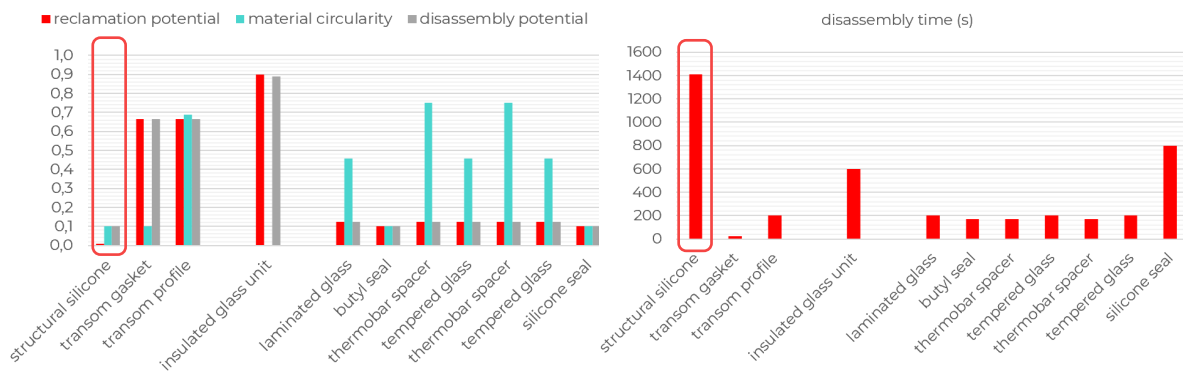


Figure 3.79. Benchmark results for Scenario 02. (Author).

### Benchmark Results: Original Design

After conducting the assessment for the original design of the Triodos Bank Facade detail, it is evident that the transom silicone contributes to a lower disassembly potential of the system, since the toggle system has to be concealed from weather. This part has the potential to be improved, which could significantly reduce the disassembly time and increase the reclamation potential of the system if another type of sealing is used.

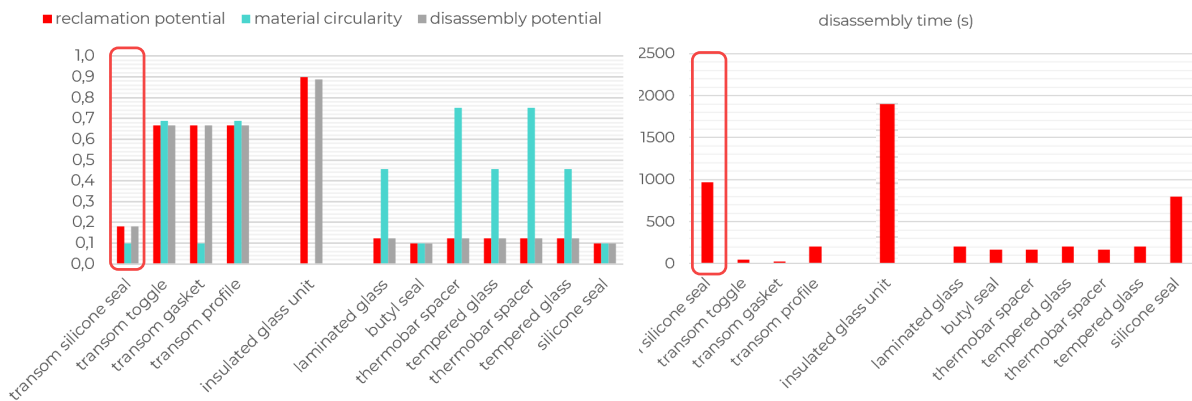


Figure 3.80. Benchmark results for Original Design. (Author).

### 7.10 Design Improvement

From prior benchmarking results, design enhancements are proposed. Given the importance of aesthetics, an alternative sealing method is needed that maintains the original look, reduces disassembly duration, and boosts reclamation potential. Figure 3.81 shows using a gasket instead of the sealing compound, based on the GUTMANN F50++ SS system (Gutman North America, 2023), detailed in Appendix 10.7. The toggle system supporting the glazing remains due to its effective structural support. As depicted in Figure 3.81, disassembly time reduces significantly, and the gasket system offers greater reclamation potential than the original silicone sealant.

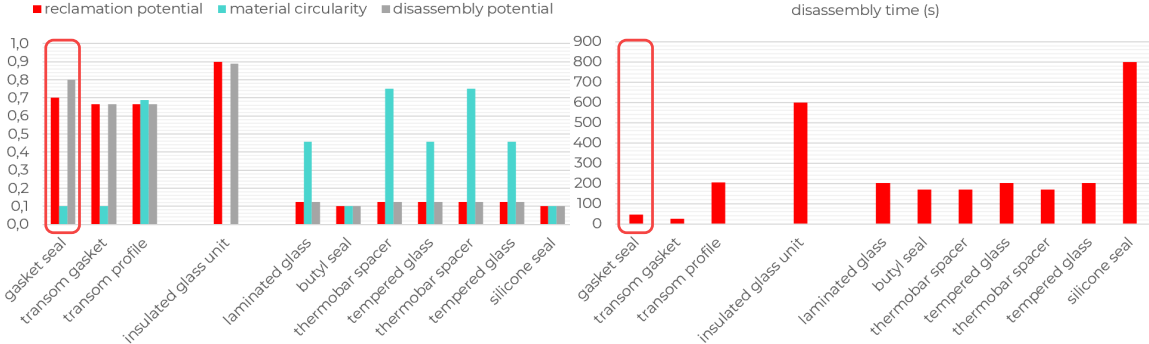
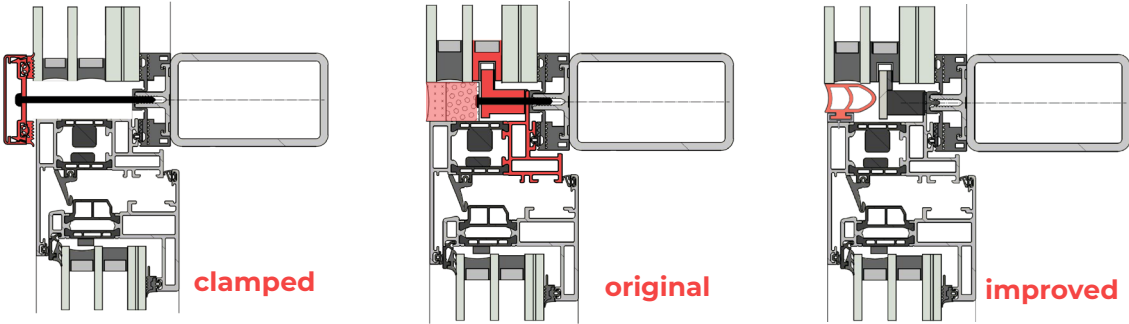
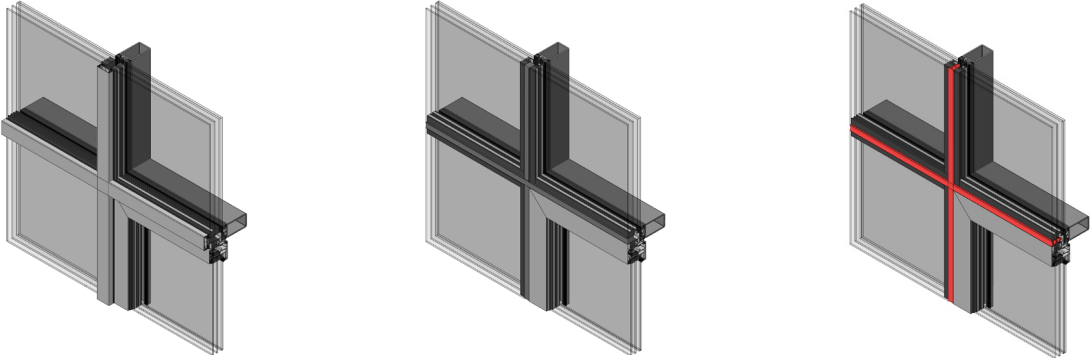


Figure 3.81. Benchmark results for Design Improvement. (Author).



As can be seen in the figure below, the proposed design improvement has a similar aesthetic effect as the original design.



## 7.11 User Output

From the derived assessment modules, a visual output is proposed for the easy identification of bottlenecks regarding the disassembly potential of the analyzed system. The output shows the ratings of each assessed modules, so the involved stakeholder has a better understanding of how design choices affect the reclamation potential of the façade. Additional modules can be assessed at the EoL of the façade based on the initial process. Figure 3.82 illustrates the Disassembly Map of the analyzed system and how the selected connection performs in terms of the different evaluated parameters of the assessment method.

1. **Penalties:** Additionally, based on the Disassembly Map principle proposed by (De Fazio, 2021), penalties could potentially be introduced based on predefined thresholds. This could include penalties regarding the use of uncommon tools or overstepping a set limit of disassembly time.
2. **Reuse Threshold:** Based on research conducted regarding the Building Circularity Indicator (BCI) in Section 00, a threshold of (0,6) could penalize connections where potentially destructive methods have to be employed.

input for assessment

disassembly map to visualize bottlenecks in the design

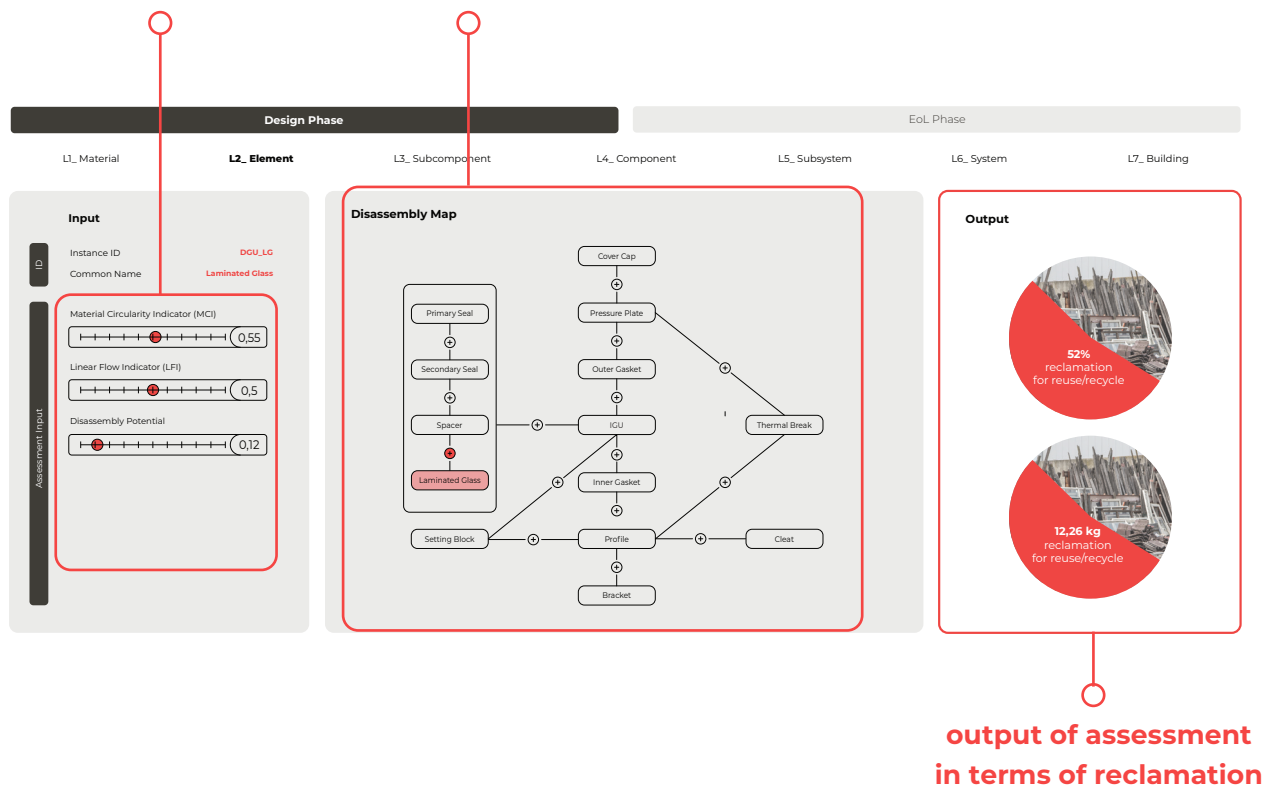


Figure 3.82. Visual mockup of the assessment platform. (Author)



## 8 Conclusions

## 8.1 Conclusions

This chapter outlines the practical application of a framework through a case study provided by Octatube, focusing on the Triodos Bank aluminum stick system façade, which is significant example in the European market. The main objective was to test the framework's ability to assess the potential for reclaiming components using Design for Disassembly (DfD) criteria. Two additional scenarios were developed to benchmark the existing design against conventional systems and to suggest design improvements based on these insights.

A hierarchical structure for classifying façade elements was introduced, demonstrating the importance of systematic data collection and organization into database templates. The chapter also explored material databases, disassembly process databases, and connection databases, which give structure to the assessment and could potentially lead to digital optimization tools.

1. **Disassembly Potential:** This method evaluates the ease of removing elements during design but carries the risk of subjectivity, which could lead to inaccuracies and potentially misleading environmental claims.
2. **Material Circularity Indicator:** This method identifies materials that could enhance their circularity in terms of recycled or reused content. However, the assessment relies on the availability of information, which can make the evaluation challenging and time-intensive.
3. **Reclamation Potential:** This method holds promise in providing insights into how Design for Disassembly influences material reclamation for reuse. However, it is tied to the Disassembly Potential assessment which is a qualitative assessment, consequently, calculation results can depend on personal interpretation.
4. **Disassembly Time:** While capable of shedding light on the financial aspects of the disassembly process, it is important to note that this method can be resource-intensive. Additionally, data on disassembly times for facades is scarce, but could potentially be extended with further research.

The assessment framework led to a design enhancement that could lead to the highest material reclamation potential. Yet, this improved design requires further testing for water-tightness and condensation resistance. The primary aim of this research was to simplify the disassembly process, a goal that was met. Future steps might include creating a prototype of the design and evaluating its performance in terms of disassembly time on a practical level.

## 8.2 Answering Research Questions

Presently, there are numerous methodologies available for assessing nearly every aspect of product design. This abundance of tools contributes to the challenge of establishing an universal standard. This research proposed a disassembly assessment method based on established criteria, but integrating them in a comprehensive and holistic way.

1. How can a disassembly assessment framework be developed to specifically evaluate the influence of design for disassembly on material reclamation at the end of life of curtain wall façade systems?

A disassembly assessment framework for evaluating the influence of design for disassembly on material reclamation at the end of life for the curtain wall façade system was comprehensively approached. To ensure a structured analysis, a hierarchical categorization system for façade elements was developed, underscoring the importance of systematic data collection and organization. Three key databases were established: one for material properties, another for disassembly processes, and a third for connections, providing the necessary structure for systematic assessment.

Four assessment methods were employed: The Disassembly Potential method evaluated the ease of detaching elements, acknowledging the potential subjectivity in the assessment process. The Material Circularity Indicator assessed the efficient use of reused/recycled materials in the design process. The Reclamation Potential was calculated based on the Predictive Building Circularity Indicator (PBCI), revealing how Design for Disassembly influenced material reclamation and reuse potential. Lastly, the Disassembly Time (eDiM) method considered the financial aspects of the disassembly process, although it could be resource-intensive.

This research developed a disassembly assessment framework and applied it in a case study of the Triodos Project supplied by Octatube. Design recommendations were made, demonstrating the utility of the framework. The aim of the research was to evaluate the influence of design for disassembly on material reclamation at end-of-life for facade systems, emphasizing the significance of structured data, comprehensive assessment methods, and the consideration of challenges in time-consuming assessment frameworks.

1. What are the challenges and opportunities associated with implementing circular design principles in façade materials and products within the façade supply chain?

Through an extensive literature review, challenges and opportunities in implementing DfD in the façade industry have been identified. The need for extensive data collection and organization, potential subjectivity in assessment processes, and resource demands for comprehensive analyses are potential challenges in the process. Additionally, aligning stakeholders' awareness and commitment to circularity can be challenging. However, these challenges also signify opportunities. By developing structured databases, employing systematic assessment methods, and fostering industry-wide collaboration and awareness, the façade supply chain can harness the potential for more sustainable and circular design practices. This can result in reduced waste, minimized environmental impact, and the creation of more eco-friendly and resource-efficient façade products, contributing to a greener and more circular built environment.

2. How can the impact of different design choices based on DfD be quantitatively assessed? What are the available metrics?

Key metrics include the Disassembly Potential, which evaluates the ease of element detachment, considering factors like connectors, tools, and manipulations. Another metric is the Material Circularity Indicator (MCI), which assesses the circularity of materials used, considering the proportion of virgin, recycled, and reused content. The Predictive Building Circularity Indicator (PBCI) predicts material reclamation potential based on DfD criteria. Lastly, the Disassembly Time (eDiM) metric calculates the time required for disassembly. These metrics provide quantitative insights into the sustainability and efficiency of different design choices influenced by DfD principles. The metrics were based on the Disassembly Potential framework by the Dutch Green Building Council, which is already being considered for implementation into BREEAM Certifications.

3. To what extent can a framework that incorporates DfD provide a comprehensive view of how various parameters affect façade systems' end of life reclamation?

A framework that incorporates Design for Disassembly (DfD) can provide a comprehensive view of how various parameters affect façade systems' end of life reclamation to a significant extent. By considering factors such as Disassembly Potential, Material Circularity Indicator (MCI), Predictive Building Circularity Indicator (PBCI), and Disassembly Time (eDiM), the framework offers a holistic assessment of the reclamation potential based on existing frameworks. It

quantifies the ease of disassembly, material circularity, reclamation potential, and disassembly time, allowing for a thorough understanding of the impact of different parameters on the end of life reclamation of façade systems. This comprehensive view aids in making informed decisions during the design phase to optimize material reclamation and sustainability in façade systems.

**4.** How can the data required to conduct disassembly assessment be structured in a comprehensive way and lead to implementation of digital tools?

To structure the data required for disassembly assessment comprehensively and enable the implementation of digital tools, a systematic approach involves creating databases for materials, processes, and connections within façade systems. These databases should include information on material properties, sources, production processes, connector types, quantities, and ease of disassembly. Organizing façade components into a hierarchical structure further aids in understanding their relationships and functions. To implement digital tools effectively, data should be standardized, potentially using formats like Industry Foundation Classes (IFC), for compatibility with common façade industry software. Once structured, these data repositories can support the development of digital tools such as Building Information Modeling (BIM) software and simulation models, streamlining the disassembly assessment process, and providing valuable insights for stakeholders in the design and end of life phases of façade systems.

**5.** How can the disassembly assessment framework be extended to inform the reclamation potential of *existing* curtain wall façade stick systems?

Extending the disassembly assessment framework to inform the reclamation potential of existing stick façade systems involves adapting the framework to accommodate retrospective evaluations. This can be achieved by gathering relevant data about the existing façade systems, such as their design specifications, material properties, and as-built conditions. The framework should incorporate the assessment of disassembly first, after which it is possible to evaluate condition, performance and design criteria. Additionally, the framework should consider the specific challenges and constraints associated with retrofitting or disassembling already-installed façades. By including these elements, the framework can provide insights into the reclamation potential of existing stick façade systems, enabling stakeholders to make informed decisions about renovation, refurbishment, or end of life strategies for such systems.

## 8.3 Limitations and Recommendations

### Limitations

1. Although LCA were reviewed in the literature, there is a gap on how DfD can relate to environmental impact in terms of embodied carbon. Precaution has to be taken in order to not double-count embodied carbon savings.
2. Circularity indicators and specifically DfD principles are constantly being redeveloped. The vast amount of assessment tools make implementation in the design process significantly difficult.
3. There is a lack of data required to conduct the assessment, thus making an objective evaluation difficult. If more data were available, the process could be streamlined. Assumptions regarding time and disassembly sequences were made.
4. The assessment has a certain degree of subjectivity, especially in terms of Disassembly Potential, due to the nature of the method. This means that results are dependent on the criteria of the person evaluating.
5. A significant observation from the research is that due to the vast amount of connection types and customizations within current aluminum façade systems and the wide variety in product types, it is difficult to streamline the process.

### Recommendations

6. Despite the rapid pace of product development, it might be beneficial to decrease the customization level in façade products, by standardizing connection types, thus reducing disassembly time and effort. This would ensure that façades can be effortlessly disassembled by any builder or deconstruction company, even in the absence of detailed information on disassembly sequences. A shift towards more standardized, simplified sections and connection systems, could eliminate the need for specialized assembly or disassembly tools.
7. Technological barriers regarding adhesive sealants could be overcome with the advancement of technology. For instance, laminated glazing is difficult to separate due to the adhesive interlayer. This results in difficult recycling and even reuse of elements and materials.



highlight  
design barriers



promote resource  
efficiency



reduction of  
demolition waste



regulatory  
implications



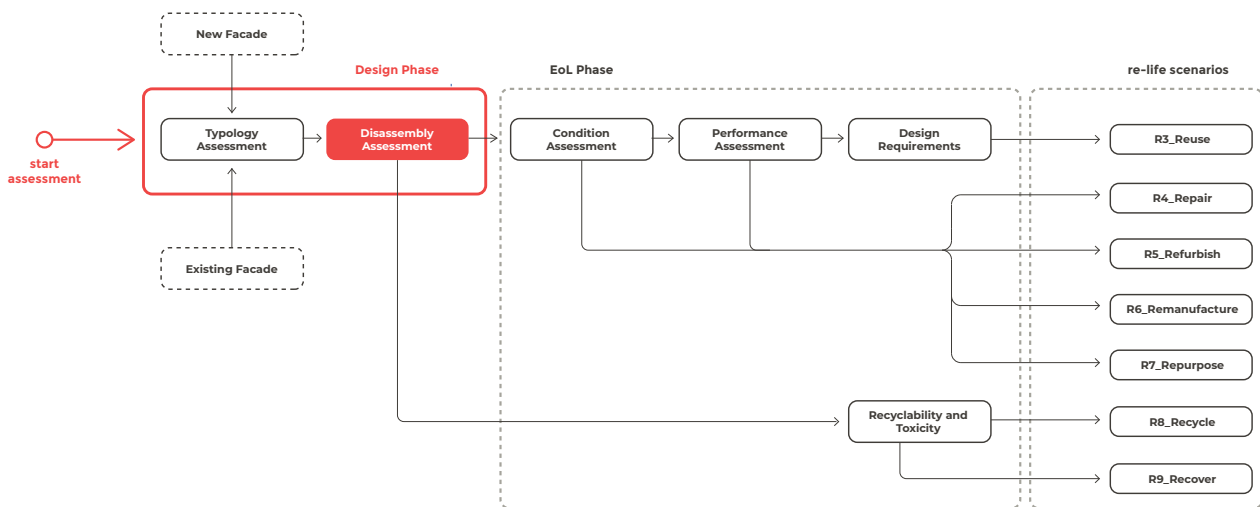
stakeholder  
awareness



## 8.4 Opportunities and Further Research

### Further Research

1. Test framework with stakeholder involvement in the design stage to further improve the workflow.
2. Testing framework on different facade types to create facade archetypes based on their reclamation potential. This could also streamline databases and potentially allow for an automated predictive reclamation assessment.
3. Developing Database Driven computational workflows.
4. Test disassembly time on 1:1 facades that are set to be removed. Involve demolition experts to verify the process. This could help validate the predicted reclamation potential with real percentages of reclaimed materials.
5. Comparing reclamation potential based on DfD with embodied carbon impacts. This could be done through comparative LCA where scenarios could be constructed for different facade typologies and material reclamation routes.
6. Implement the EoL Assessment Modules, based on the criteria for evaluation discussed Section 6.8.



### Opportunities



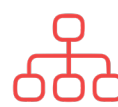
design  
optimizations



recycling and  
material reclamation



outlook for  
digitalization



framework  
design



link to  
life cycle assessment

# 9 References

## 9.1 References

- Åke, S., & Tawfic, M. (2011). Life Cycle Assessment. The Greenhouse Effect, Climate Change and the Road to Sustainability. Retrieved June 5, 2023, from <https://grimstad.uia.no/puls/climatechange2/nns05/13nns05a.htm>
- Akinade, O. O., Oyedele, L. O., Oyedele, A., Bilal, M., Akanbi, L., & Ajayi, A. O. (2019). Design for deconstruction using a circular economy approach: barriers and strategies for improvement. *Production Planning & Control*, 31(10), 829–840. <https://doi.org/10.1080/09537287.2019.1695006>
- Ansys. (2022). Granta EduPack (Version R1) [Software].
- Arup. (2016). The Circular Economy in the Built Environment. Retrieved February 3, 2023, from <https://www.arup.com/services/climate-and-sustainability-services/circular-economy-services/the-circular-economy>
- Arup & Frener Reifer. (2019). Design Innovation: Materials and Design Exchange Project for End of life uilding Façades.
- Arup & Saint-Gobain. (2021). Carbon footprint of façades: Significance of glass. Arup. <https://www.arup.com/news-and-events/arup-announces-international-dataset-of-whole-life-carbon-emissions-for-buildings-at-cop27>
- Azcarate, J., Klein, T., Den Heijer, A., Vrijhoef, R., Ploeger, H., & Prins, M. (2018). Drivers and barriers to the delivery of integrated Façades-as-a-Service. *Real Estate Research Quarterly*.
- Bakker, C., Hollander, M. D., Van Hinte, E., & Zijlstra, Y. J. (2020). Products That Last: Product Design for Circular Business Models. Delft University of Technology.
- Beurskens, P., Ritzen, M., & Bakx, M. (2016). A morphological design and evaluation model for the development of circular façades. *Sustainable Built Environment (SBE)*.
- Boks, C., Kroll, E., Brouwers, W., & Stevels, A. (2002). Disassembly modeling: two applications to a Philips 21&quot; television set. *IEEE*. <https://doi.org/10.1109/isee.1996.501882>
- Boorsma, N., Peck, D., Bakker, T., Bakker, C., & Balkenende, R. (2022). The strategic value of design for remanufacturing: a case study of professional imaging equipment. *Journal of Remanufacturing*, 12(2), 187–212. <https://doi.org/10.1007/s13243-021-00107-0>
- Boorsma, N., Polat, E., Bakker, C., Peck, D., & Balkenende, R. (2022). Development of the Circular Product Readiness Method in Circular Design. *Sustainability*, 14(15), 9288. <https://doi.org/10.3390/su14159288>
- Brancart, S., Rajagopalan, N., De Regel, S., Paduart, A., De Temmerman, N., & Debacker, W. (2021). Multi-Criteria decision analysis using life cycle assessment and life cycle costing in circular building design: A case study for wall partitioning systems in the Circular Retrofit Lab. *Sustainability*, 13(9), 5124. <https://doi.org/10.3390/su13095124>
- Brand, S. (1995). *How Buildings Learn: What Happens After They're Built*. Penguin Books.
- Brocke, J. V., Hevner, A. R., & Maedche, A. (2020). Introduction to Design Science Research. Springer International Publishing eBooks, 1–13. [https://doi.org/10.1007/978-3-030-46781-4\\_1](https://doi.org/10.1007/978-3-030-46781-4_1)
- Chastas, P., Theodosiou, T., Bikas, D., & Kontoleon, K. J. (2017). Embodied energy and nearly zero energy buildings: A review in Residential buildings. *Procedia Environmental Sciences*, 38, 554–561. <https://doi.org/10.1016/j.proenv.2017.03.123>

- Cheshire, D. (2016). *Building Revolutions: Applying the Circular Economy to the Built Environment* (1st ed.). RIBA Publishing.
- Chini, A., & Schultmann, F. (Eds.). (2002). *Design for Deconstruction and Materials Reuse* (272nd ed.). CIB.
- Cirlingq. (2023). Retrieved March 11, 2023, from <https://www.cirlingq.nl/inzicht/identificatie/?lang=en>
- Conditioescores NEN 2767. (2021, November 4). VHB Assetmanagement En Advies. <https://vhb.nu/kennisbank/conditioescores-nen-2767/>
- Copeland, S., & Bilec, M. M. (2020). Buildings as material banks using RFID and building information modeling in a circular economy. *Procedia CIRP*, 90, 143–147. <https://doi.org/10.1016/j.procir.2020.02.122>
- Corona, B., Shen, L., Reike, D., Carreón, J. R., & Worrell, E. (2019). Towards sustainable development through the circular economy—A review and critical assessment on current circularity metrics. *Resources Conservation and Recycling*, 151, 104498. <https://doi.org/10.1016/j.resconrec.2019.104498>
- Cottafava, D., & Ritzen, M. (2021). Circularity indicator for residential buildings: Addressing the gap between embodied impacts and design aspects. *Resources Conservation and Recycling*, 164, 105120. <https://doi.org/10.1016/j.resconrec.2020.105120>
- Crowther, P. (2005). *Design for Disassembly – Themes and Principles*. *Environment Design Guide*, DES 31. <https://www.jstor.org/stable/26149108>
- De Fazio, F., Bakker, C., Flipsen, B., & Balkenende, R. (2021). The Disassembly Map: A new method to enhance design for product reparability. *Journal of Cleaner Production*, 320, 128552. <https://doi.org/10.1016/j.jclepro.2021.128552>
- Durmisevic, E. (2006). *Transformable building structures: Design for disassembly as a way to introduce sustainable engineering to building design & construction* [PhD Dissertation]. TU Delft.
- Durmisevic, E., Beurskens, P., Adrosevic, R., & Westerdijk, R. (Eds.). (2017). *Systemic view on reuse potential of building elements, components and systems - comprehensive framework for assessing reuse potential of building elements* [International HISER Conference on Advances in Recycling and Management of Construction and Demolition Waste].
- Dutch Green Building Council. (2021). *Disassembly Potential Measurement Method*.
- Eckersley O'Callaghan. (2021). Embodied carbon and the path to net zero façades. Retrieved April 2, 2023, from <https://www.eocengineers.com/climate-friday-embodied-carbon-and-the-path-to-net-zero-facades/>
- Eekhout, M. (1996). *POPO of ontwerpmethoden voor bouwproducten en bouwcomponenten*. Delft University Press.
- Ellen MacArthur Foundation. (2015). *Material Circularity Indicator*. <https://ellenmacarthurfoundation.org/material-circularity-indicator>
- Ellen McArthur Foundation. (2013). *Towards the circular economy Vol. 1: An economic and business rationale for an accelerated transition*. <https://www.ellenmacarthurfoundation.org/assets/downloads/publications/Ellen-MacArthur-Foundation-Towards-the-Circular-Economy-vol.1.pdf>
- Embodied carbon. (n.d.).

- Escalreira, C., Amoêda, R., & Cruz, P. J. (2019). Connections and joints in buildings: Revisiting the main concepts on building materials life cycle's circularity. *IOP Conference Series: Earth and Environmental Science*, 225, 012062. <https://doi.org/10.1088/1755-1315/225/1/012062>
- European Commission. (2015). Closing the loop - An EU action plan for the Circular Economy (No. 614). European Union. Retrieved March 7, 2023, from <http://eur-lex.europa.eu/legal-content/EN/TXT/?uri=CELEX:52015DC0614>
- European Commission. (2018). Construction and Demolition Waste. Environment. Retrieved January 3, 2023, from [https://environment.ec.europa.eu/topics/waste-and-recycling/construction-and-demolition-waste\\_en](https://environment.ec.europa.eu/topics/waste-and-recycling/construction-and-demolition-waste_en)
- European Environment Agency. (2020). Examples of circular actions that improve the management of construction and demolition waste. <https://www.eea.europa.eu/media/infographics/examples-of-circular-actions-that/view>
- Formentini, G., & Ramanujan, D. (2023). Design for circular disassembly: Evaluating the impacts of product end of life status on circularity through the parent-action-child model. *Journal of Cleaner Production*, 405, 137009. <https://doi.org/10.1016/j.jclepro.2023.137009>
- Gamerschlag, H. (2020). Closing Loops [Master Thesis]. Delft university of Technology.
- GSF Glasgroep. (2023, January 7). IsoMax - GSF glasgroep. <https://gsfglasgroep.nl/isomax/>
- Gungor, A., & Gupta, S. M. (1998). Disassembly sequence planning for products with defective parts in product reclamation. *Computers & Industrial Engineering*, 35(1-2), 161-164. [https://doi.org/10.1016/s0360-8352\(98\)00047-3](https://doi.org/10.1016/s0360-8352(98)00047-3)
- Guy, B., & Ciarimboli, N. (2005). Design for Disassembly in the Built Environment. Seattle: Hamer Center for Community Design. Retrieved December 12, 2022, from <http://www.lifecyclebuilding.org/~lifecyc6/>
- Hartwell, R., Macmillan, S., & Overend, M. (2021). Circular economy of façades: Real-world challenges and opportunities. *Resources, Conservation and Recycling*, 175, 105827. <https://doi.org/10.1016/j.resconrec.2021.105827>
- Hartwell, R., & Overend, M. (2019). Unlocking the Re-use Potential of Glass Façade Systems. *Glass Performance Days*.
- Heinrich, M. A., & Lang, W. (2019). Materials Passports - Best Practice. Institute of Energy Efficient and Sustainable Design. <https://doi.org/10.5281/zenodo.2556515>
- Honic, M., Kovacic, I., & Rechberger, H. (2019). Improving the recycling potential of buildings through Material Passports (MP): An Austrian case study. *Journal of Cleaner Production*, 217, 787-797. <https://doi.org/10.1016/j.jclepro.2019.01.212>
- International Organization for Standardization. (2006). Environmental management: life cycle assessment; requirements and guidelines. Geneva, Switzerland: ISO.
- Joensuu, T., Leino, R., Heinonen, J., & Saari, A. (2022). Developing Buildings' Life Cycle Assessment in Circular Economy-Comparing methods for assessing carbon footprint of reusable components. *Sustainable Cities and Society*, 77, 103499. <https://doi.org/10.1016/j.scs.2021.103499>
- Juaristi, M., Sebastiani, I., & Avesani, S. (2022). Timber-based Façades with Different Connections and Claddings: Assessing Materials' Reusability, Water Use and Global Warming Potential. *Journal of Façade*

Design and Engineering, 10(2), 71–86. <https://doi.org/10.47982/jfde.2022.powerskin.5>

Klein, T. (2013). Integral Façade Construction: Towards a new product architecture for curtain walls. <http://abe.tudelft.nl/article/view/klein/klein>

Klett, J. (2009). Systematic Design of Connections under Consideration of Assembly and Disassembly Related Properties [PhD dissertation]. Technische Universität Berlin.

Konstantinou, T., Giovanardi, M., Pollo, R., & Klein, T. (2023). Internet of Things for building façade traceability: A theoretical framework to enable circular economy through life-cycle information flows. *Journal of Cleaner Production*, 382, 135261. <https://doi.org/10.1016/j.jclepro.2022.135261>

Kroll, E., & Hanft, T. A. (1998). Quantitative evaluation of product disassembly for recycling. *Research in Engineering Design*, 10(1), 1–14. <https://doi.org/10.1007/bf01580266>

Lam, W. C., Claes, S., & Ritzen, M. (2022). Exploring the Missing Link between Life Cycle Assessment and Circularity Assessment in the Built Environment. *Buildings*, 12(12), 2152. <https://doi.org/10.3390/buildings12122152>

Lambert, A. J., & Gupta, S. M. (2008). Methods for optimum and near optimum disassembly sequencing. *International Journal of Production Research*, 46(11), 2845–2865. <https://doi.org/10.1080/00207540601120484>

Lausset, C., Dahlstrøm, O. A., Thyholt, M., Eghbali, A., & Schneider-Marín, P. (2023). Methods to account for Design for Disassembly: Status of the building sector. *Buildings*, 13(4), 1012. <https://doi.org/10.3390/buildings13041012>

Madaster Platform. (2023). Madaster Global. <https://madaster.com/platform/>

Meijs, M., & Knaack, U. (2009). *Components and Connections: Principles of Construction*. Walter de Gruyter.

Michael, C. (2016). Design for Disassembly for Façade Components in the Circular Economy [MSc in Building Technology Thesis]. TU Delft.

Morini, A. A., Ribeiro, M., & Hotza, D. (2019). Early-stage materials selection based on embodied energy and carbon footprint. *Materials & Design*, 178, 107861. <https://doi.org/10.1016/j.matdes.2019.107861>

Overvest, M. (2023). Circular Economy — Transforming sustainable procurement. *Procurement Tactics*. <https://procurementtactics.com/circular-economy/>

PBL. (2018). Circular Economy: What we want to know and can measure. Netherlands Environmental Assessment Agency. Retrieved March 1, 2023, from <https://www.pbl.nl/en/publications/circular-economy-what-we-want-to-know-and-can-measure>

Platform CB23. (2018). Passports for the Construction Sector. Version 2.0.

Pomponi, F., & Moncaster, A. (2016). Embodied carbon mitigation and reduction in the built environment – What does the evidence say? *Journal of Environmental Management*, 181, 687–700. <https://doi.org/10.1016/j.jenvman.2016.08.036>

Potting, J., Hekkert, M., & Hanemaaijer, A. (2016). Circular economy: Measuring innovation in the product chain. PBL Netherlands Environmental Assessment Agency.

Reversible Building Design. (2019, May 14). BAMB. <https://www.bamb2020.eu/topics/reversible-building->



design/

Reynaers Aluminium. (2021). Product downloads. <https://www.reynaers.com/downloads/product-downloads>

Reynaers Aluminium. (2023). Concept Wall 60. <https://www.reynaers.com/products/façades/conceptwall-60>

Rios, F. C., Chong, W. C., & Grau, D. (2015). Design for Disassembly and Deconstruction - Challenges and Opportunities. *Procedia Engineering*, 118, 1296–1304. <https://doi.org/10.1016/j.proeng.2015.08.485>

Saidani, M., Yannou, B., Leroy, Y., Cluzel, F., & Kendall, A. (2019). A taxonomy of circular economy indicators. *Journal of Cleaner Production*, 207, 542–559. <https://doi.org/10.1016/j.jclepro.2018.10.014>

Sassi, P. (2009). Closed Loop Material Cycle Construction [PhD Dissertation]. Cardiff University.  
Sonnenberg, M. (2001). Force and Effort Analysis of Unfastening Actions in Disassembly Processes [PhD Dissertation]. New Jersey Institute of Technology.

Sonnenberg, M., & Sodhi, R. (2002). Influence of Fasteners on Disassembly of Products. *International Journal of Industrial Engineering : Theory Applications and Practice*, 10(3), 271–278.  
Stichting Nationale Milieudatabase. (n.d.). End of life scenarios. NMD. [https://milieudatabase.nl/en/environmental-data-lca/information-for-life-cycle-assessment-lca-practitioners/end-of-life-scenarios/#:~:text=Definition%20of%20&apos;End%20of%2D,or%20without%20reprocessing\)%20or%20reuse.](https://milieudatabase.nl/en/environmental-data-lca/information-for-life-cycle-assessment-lca-practitioners/end-of-life-scenarios/#:~:text=Definition%20of%20&apos;End%20of%2D,or%20without%20reprocessing)%20or%20reuse.)

Ulrich, K. (1995). The role of product architecture in the manufacturing firm. *Research Policy*, 24(3), 419–440. [https://doi.org/10.1016/0048-7333\(94\)00775-3](https://doi.org/10.1016/0048-7333(94)00775-3)

Van Der Molen, F. (2020). Partnerschap Madaster en Smart Workplace voor circulaire werkomgeving. *Duurzaam Ondernemen*. <https://www.duurzaam-ondernemen.nl/partnerschap-madaster-en-smart-workplace-voor-circulaire-werkomgeving/>

Van Vliet, M., Van Grinsven, J., & Teunizen, J. (2021). Circular Buildings: Disassembly Potential Measurement Method. Dutch Green Building Council.

Vanegas, P., Peeters, J., & Cattrysse, D. (2016). Study for a method to assess the ease of disassembly of electrical and electronic equipment. European Commission.

Vanegas, P., Peeters, J. R., Cattrysse, D., Tecchio, P., Ardente, F., Mathieux, F., Dewulf, W., & Duflou, J. R. (2018). Ease of disassembly of products to support circular economy strategies. *Resources, Conservation and Recycling*, 135, 323–334. <https://doi.org/10.1016/j.resconrec.2017.06.022>

Verberne, J. (2016). Building Circularity Indicators an Approach for Measuring Circularity of a Building [Master Thesis]. Eindhoven University of Technology.

Vliet, M. (2018). Disassembling the steps towards building circularity: redeveloping the building disassembly assessment method in the building circularity indicator [MA Thesis]. Eindhoven University of Technology.

Zandin, K. B. (2020). MOST® work measurement systems. In CRC Press eBooks. <https://doi.org/10.1201/9780429326424>

# 10 Appendix

## 10.1 Material Circularity Indicator Calculation

### Step 1: Calculation Virgin Feedstock

$$V_{(x)} = M_{(x)}(1 - F_{R(x)} - F_{U(x)})$$

Symbol	Definition
$V_{(x)}$	Virgin feedstock per subassembly/material
$M_{(x)}$	Mass of product (kg)
$F_{R(x)}$	Fraction of mass of product's feedstock from recycled sources
$F_{U(x)}$	Fraction of mass of product's feedstock from reused sources

$$V = \sum_x V_{(x)}$$

Symbol	Definition
$V$	Total amount of virgin feedstock
$V_{(x)}$	Virgin feedstock per subassembly/material

### Step 2: Calculation Unrecoverable Waste

$$W_{0(x)} = M_{(x)}(1 - C_{R(x)} - C_{U(x)})$$

Symbol	Definition
$W_{0(x)}$	Mass of unrecoverable waste of a product's subassembly/material ending as landfill, incinerated for energy recovery or rendered in any other way unrecoverable
$M_{(x)}$	Mass of product's subassembly/material
$C_{R(x)}$	Fraction of mass of a product's subassembly/material being collected for recycling at the end of the use phase
$C_{U(x)}$	Fraction of mass of a product's subassembly/material being collected for reuse at the end of the use phase

$$W_{C(x)} = M_{(x)}(1 - E_{C(x)})C_{R(x)}$$

Symbol	Definition
$W_{C(x)}$	Mass of unrecoverable waste of a product's subassembly/material caused during recycling parts of a product
$M_{(x)}$	Mass of a product's subassembly/material
$E_{C(x)}$	Efficiency of the recycling process used for the portion of a product collected for recycling
$C_{R(x)}$	Fraction of mass of a product's subassembly/material being collected for recycling at the end of the use phase

$$W_{F(x)} = M_{(x)} \frac{(1 - E_{F(x)}) * F_{R(x)}}{E_{F(x)}}$$

Symbol	Definition
$W_{F(x)}$	Mass of unrecoverable waste of a product's subassembly/material caused during producing recycled feedstock of a product
$M_{(x)}$	Mass of a product's subassembly/material
$E_{F(x)}$	Efficiency of the recycling process of a product's subassembly/material used to produce recycled feedstock for a product
$F_{R(x)}$	Fraction of mass of a product's feedstock from recycled origin

$$LFI = \frac{V + W}{2M + \sum_x \frac{W_{F(x)} - W_{C(x)}}{2}}$$

Symbol	Definition
<i>LFI</i>	Linear Flow Index
<i>V</i>	Total amount of virgin feedstock
<i>W</i>	Total mass of unrecoverable waste related to a product
<i>M</i>	Mass of product (kg)
$W_{F(x)}$	Mass of unrecoverable waste of a product's subassembly/material caused during producing recycled feedstock of a product
$W_{C(x)}$	Mass of unrecoverable waste of a product's subassembly/material caused during recycling parts of a product

**Step 4: Calculate Utility Factor (X)**

$$X = \left(\frac{L}{L_{av}}\right) \cdot \left(\frac{U}{U_{av}}\right)$$

Symbol	Definition
<i>X</i>	Utility Factor
<i>L</i>	Actual average lifetime of a product
$L_{av}$	Actual average lifetime of an industry-average product of the same type
<i>U</i>	Actual average functional units achieved during the use phase of the product
$U_{av}$	Actual average functional units achieved during the use phase of an industry-average product of the same type

$$F_{(x)} = \frac{0.9}{X}$$

Symbol	Definition
$F_{(x)}$	Utility factor built as a function of the utility X of a product

$$MCI_p^* = 1 - LFI \cdot F_{(x)}$$

Symbol	Definition
$MCI_p^*$	Calculation Material Circularity Indicator
<i>LFI</i>	Linear Flow Index
$F_{(x)}$	Utility factor built as a function of the utility X of a product

## 10.2 Technical Disassembly Assessment Guidelines

Connection type (CT)		Score	Independency (ID)		Score
Dry connection	Loose (no fastening material)	1,00	No independency - modular zoning of products or elements from different layers.		1.00
	Click connection		Occasional independency of products or elements from different layers.		0.40
	Velcro connection		Full integration of products or elements from different layers.		0.10
	Magnetic connection	1.00			
Connection with added elements*	Bolt and nut connection	0,80			
	Spring connection				
	Corner connections				
	Screw connection				
	Connections with added connection elements**				
Direct integral connection	Pin connections***	0,60***			
	Nail connection				
Soft chemical connection	Caulking connection	0,20			
	Foam connection (PUR)				
Hard chemical connection	Adhesive connection	0,10			
	Dump connection				
	Weld connection				
	Cementitious connection				
	Chemical anchors				
	Hard chemical connection				

Geometry of product edge (GPE)		Score
Open, no obstacle to the (interim) removal of products or elements.		1.00
Overlapping, partial obstruction to the (interim) removal of products or elements.		0.40
Closed, complete obstruction to the (interim) removal of products or elements.		0.10

Connection accessibility (CA)		Score
Freely accessible without additional actions		1.00
Accessible with additional actions that do not cause damage		0.80
Accessible with additional actions with fully repairable damage		0.60
Accessible with additional actions with partially repairable damage		0.40
Not accessible - irreparable damage to the product or surrounding products		0.10




## 10.3 eDim Calculation Table

Disassembly task	Description	Sequence	TMU	Time (s/task)
Tool Change	Fetch and Put back	A1B0G1 + A1B0P1	40	1.4
Identifying	Localising connectors			
	Visible are > 0.05 mm <sup>2</sup>			0
Manipulation	Hidden: visible are < 0.05 mm <sup>2</sup>	T10	100	3.6
	Product handling to access fasteners	A1B0G1 + L3	50	1.8
Positioning	Positioning tool onto fastener	A1B0P3A0	40	1.4
Removing	Removing separated components	A1B0G1  +  A1B0P1	40	1.4

Connectors	Connector characteristics	Tool	MOST sequence	TMU	Time (s)
Screw	Length < 2 X diameter (D)				
	Type 1 Screw D <= 6 mm	Power tool	[L3]	30	1.1
	Type 2 Screw 6 mm < D < 25mm	Power tool	[L6]	60	2.2
Type 3	Screw D <= 6 mm	Screwdriver	[L10]	100	3.6
Snapfit	Type 1 Force < 5 N	Hand	[L1]	10	0.4
	Type 2 5 < Force < 20 N	Screwdriver	[L3]	30	1.1
	Type 3 20 N < Force	Screwdriver	[L6]	60	2.2
Hinge	Type 1 Force < 5 N	Hand	[L1]	10	0.4
	Type 2 5 N < Force < 20 N	Hand	[L3]	30	1.1
	Type 3 20 N < Force	Hand	[L6]	60	2.2
Cable Plug	Type1 Force < 5 N	Hand	[L1]	10	0.4
	Type2 5 N < Force < 20 N	Hand	[L3]	30	1.1
	Type3 20 N < Force	Hand	[L6]	60	2.2
Clamp	Type1 Force < 5 N	Hand	[L1]	10	0.4
	Type2 5 N < Force < 20 N	Hand	[L3]	30	1.1
	Type3 20 N < Force	Screwdriver	[L6]	60	2.2
Tape	Type1 Force < 5 N	Hand	[L1]	10	0.4
	Type2 5 N < Force < 20 N	Hand	[L3]	30	1.1
	Type3 20 N < Force	Hand	[L6]	60	2.2

## 10.4 Arup Façade Teardown

### 2.2 Autopsy – Façade teardown at Frener & Reifer

Component	Part	Image	Material	Reason	Assembly	Reuse	Recycle
Weather gasket	Seal		EPDM	Weather resistance	Compression fit	Yes	No
Double glazed panels	Floor level units		Inner pane: laminated Outer pane: tempered	Safety	Contained within frame	Yes	No
	Upper units		Inner pane: toughened Outer pane: tempered		Contained within frame	Yes	No
	Insulated spacer		Rigid cellular thermoplastic and desiccant material	Structural stiffness, thermal resistance and moisture absorption	Sandwiched between glass panes	No**	No
-	Perimeter seal		Silicone and polyisobutylene	Structural bond and air, weather and thermal resistance	Sandwiched between glass panes	No	No

Disassembly

\*\* The desiccant generally has a 15 year life

- Other elements normally present on a facade

Frener & Reifer explained that as this was a model façade, certain components had been omitted from the model and specifically those concerned with water management.

Component	Material	Reason	Assembly	Reuse	Recycle
Water management membrane	EPDM	Water resistance	Draped	Yes	No

12

### 2.2

- Time to dis-assemble the model unit

It took two Frener & Reifer technicians with appropriate tools, assembly drawings and an access platform:

- › Approximately 45 minutes to disassemble Element 3 – Weather protection assembly
- › Approximately 80 minutes to disassemble Element 1 – Spandrel
- › Approximately 60 minutes to disassemble Element 4 – Spandrel
- › Approximately 50 minutes to disassemble Element 2 – Double-glazed unit in frame

It should be noted that the team regularly interrupted the disassembly process to photograph parts and ask questions. Without these interruptions, the disassembly would probably have taken 100 to 120 minutes.



## 10.5 Octatube Triodos Bank Disassembly Interview

Re: Interview Confirmation

AV Arno van Boxtel  
To: Sarah Droste

Start your reply all with:

Reply Reply All Forward

Fri 03/11/2023 09:58

Ik bevestig deze informatie.

Arno van Boxtel

Verzonden vanaf [Outlook voor Android](#)

**From:** Sarah Droste <[S.Droste@octatube.nl](mailto:S.Droste@octatube.nl)>  
**Sent:** Friday, November 3, 2023 9:39:15 AM  
**To:** Arno van Boxtel <[A.vanBoxtel@Octatube.nl](mailto:A.vanBoxtel@Octatube.nl)>  
**Subject:** Meeting Confirmation

Hey Arno!

Is het mogelijk dat u mij per e-mail een bevestiging kunt sturen dat ik de informatie uit ons gesprek mag gebruiken in mijn scriptierapport?

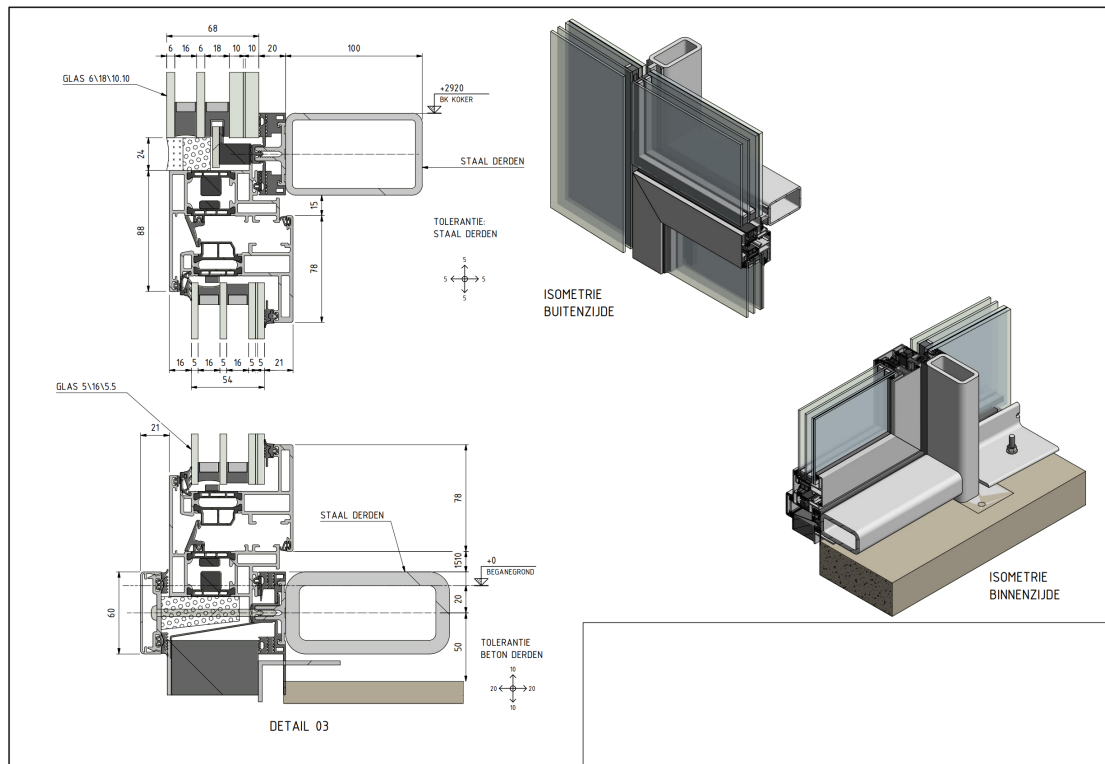
Bedankt!

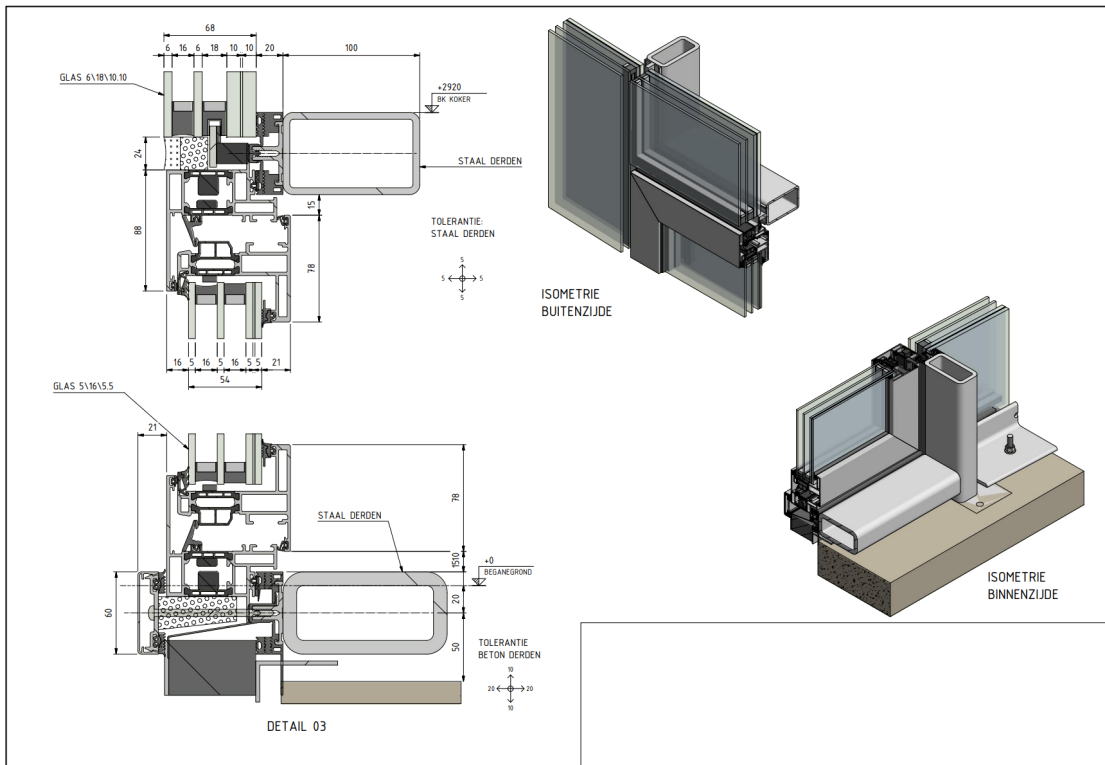
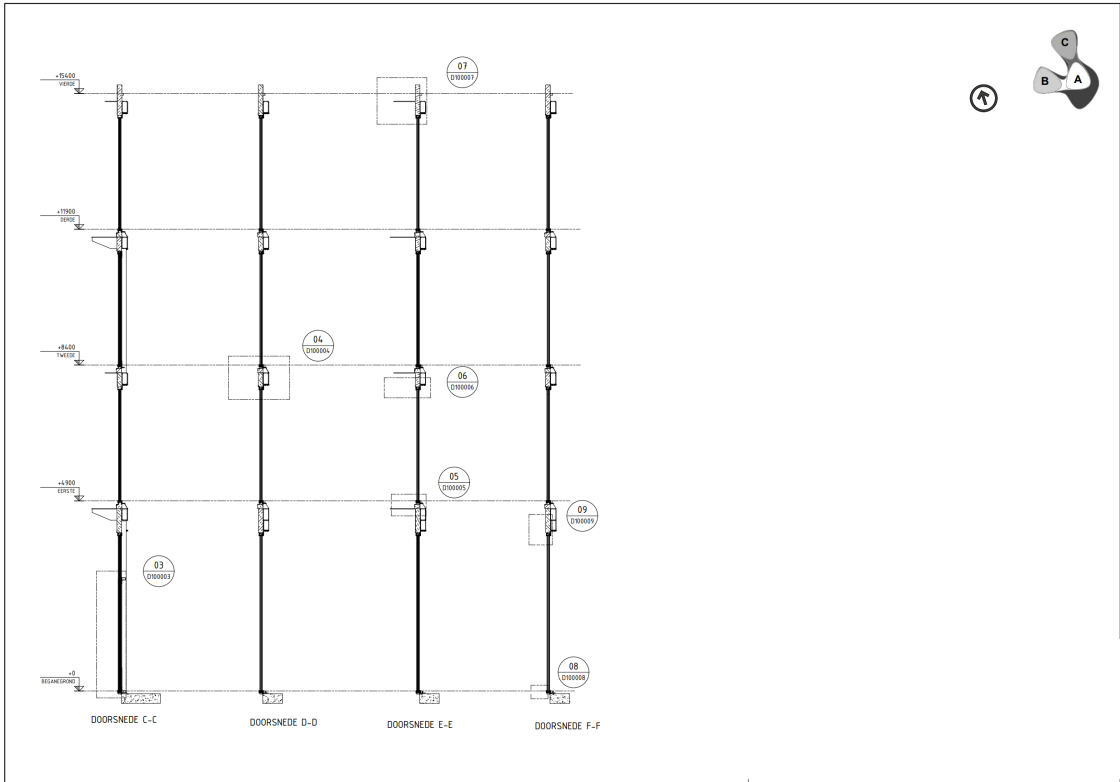
(Arno Van Boxtel, 2023) from Octatube, received Thursday 02/11/2023

Category	Question	Answer
General	What is your role at Octatube Services?	I work on-site and do façade maintenance of Octatube projects.
	When did you disassemble the façade mock-up of the Triodos Bank?	Around the beginning of 2023.
	What was the main purpose of disassembling the facade mock-up? Was it for analysis, reuse, or another purpose?	We had to clean-up the storage space for our mock-ups.
Disassembly Process	Which parts of the facade mock-up were disassembled	We only had the main glass panel with the operable window in it.
	What tools were used to disassemble the facade mock-up?	Mainly handheld tools such as impact drivers, utility knives, and screwdrivers. For the glass we used a crane with suction cups.
	Would you consider these tools unusual in the industry?	I would consider them common in the façade industry.
	How long did the actual disassembly of the facade mock-up take?	It took us two days, but we did not work on it all the time.
	Could you identify the time it took to disassemble the different components of the façade?	To take out the glass from the frame, it took us around 20 minutes, but this was after the frame was removed. The gaskets were pulled out in a matter of 1-2 minutes.
	Did you have to use cranes or other heavy equipment to disassemble the facade?	Yes, we used the crane with the suction cups.
	How many people were needed to disassemble the facade?	We were two.
	Were the connections in the facade easy or hard to access? If so, do you know which specific ones?	Yes, the adhesive used between the glass panes was difficult to remove, it took us maybe 1 hour using the cutter to get it off somehow.
	Did you encounter any unexpected challenges during disassembly?	Not unexpected, but the adhesives were a problem, sometimes they are in the gaskets.
Did you have any previous documentation on how to disassemble the facade effectively?	No.	
Material and Components	Could you estimate which elements could be reused in future designs based on their condition after disassembly?	Everything, except the gaskets and the silicone.
	Were any bolts, screws, or facade elements damaged during the disassembly process?	The silicone, and maybe the gaskets got bent.
	Did you have any safety precautions to disassemble the mock-up?	Yes, we used safety boots and protective glasses.
Safety and Equipment	Were there any safety issues or incidents during the disassembly process?	No.
Environmental Considerations	Were environmental considerations taken into account during the disassembly process, such as waste processing or recycling?	No.
After Disassembly	What happens to the facade elements after they are disassembled?	They are sent to other recycling companies. We kept the window frame, maybe it can be reused.

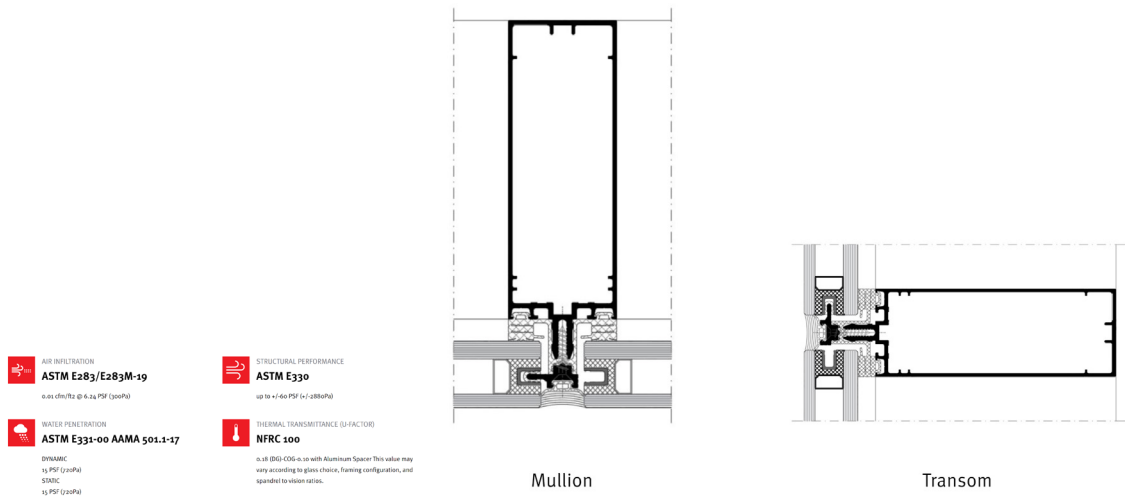
# 10.6 Triodos Bank Received Information (Octatube)

<p><b>ALGEMEEN:</b> ALLE MATEN IN MILLIMETERS VOORAANZICHTEN ZIE TEKENING A100001 VOOR DOORSNEDEN ZIE TEKENING A100002 - A100004 VOOR DETAILS ZIE TEKENING D100001 - D100009</p>	<p><b>AFMETINGEN</b> VOOR BEREKENINGEN, ZIE BEREKENINGEN RAPPORT OCTATUBE BR001 BELASTINGAANNAEMES BR002 GLAS BEREKENING</p>	<p><b>TOLERANTIES:</b> BETONWERK DERDEN HORIZONTAAL: ±20 mm BETONWERK DERDEN VERTICAAL: ±10 mm METSELERWERK DERDEN ±10 mm STAALWERK DERDEN TPV RAAMWERK HORIZONTAAL : ±5 mm STAALWERK DERDEN TPV RAAMWERK VERTICAAL : ± 5 mm STAALWERK DERDEN TPV RANDROKER/HOUTEN SPANT HORIZONTAAL : ±10 mm STAALWERK DERDEN TPV RANDROKER/HOUTEN SPANT VERTICAAL : ±20 mm OVERIGE HOUTWERK DERDEN: ±5 mm NATUURSTEENWERK DERDEN: ±5 mm PER ANKERGROEP: ±5 mm PER ANKER IN EEN ANKERGROEP: ±1 mm</p>	<p><b>ANKERS:</b> LEVERING EN PLAATSIJNG ANKERS DOOR DERDEN, VOLGENS ANKERTEKENING OCTATUBE ONDERSABELN ANKERPLATEN MET KRIMPVRIJZE MORTEL DOOR OCTATUBE</p>	<p><b>STAALWERK:</b> L-PROFIEL: 80x40x8 S235JR L-PROFIEL: 75x75x8 S235JR L-PROFIEL:130x65x8 S235JR CONSOLES STAALPLAAT: S355JR</p>	<p><b>ALUMINIUM PROFIELEN:</b> ADD-ON CONSTRUCTION: AOC S160- STANDAARD PROFIELEN SCHÜCO, EN-AW-6060 T60</p>	<p><b>ALUMINIUM RAAMKOZIJNEN:</b> RAAMKOZIJNEN - SCHÜCO AWS 75-BS-H1, EN-AW-6060 T60 INGRAAKVERBODENDE KLASSE 2 VERBORGEN SCHARNIEREN, 10 SLUITNOKKEN RAAMGREEP SCHÜCO 24-7001, BLANK GEANDUISEERD OPENINGSBEGRENZER TOT 100MM (BEHALVE VOOR 10 'DEUREN', DAAR HANDGREEP MET SLUITING)</p>	<p><b>GLASVERBINDING:</b> HORIZONTAAL: GLAS LIJNVORMIG OPELEGD, MECHANISCH BEVESTIGD MET EEN KLEMLIJST VERTICAAL: RONDOM RAAM, MECHANISCH BEVESTIGD MET EEN TOGGLE, OVERIGE KIT VERBINDING</p>	<p><b>GLAS:</b> TYPE 01: BEGANE GROND ISOLATIEPANEEL 6/16/6/18/10.10.4 6 mm VÖLLEDIG GEHARD, BLANK FLOATGLAS (HEATSOAK- TESTED) COATING: HP 70/35 GUARDIAN 18 mm SPOUW ARGON GEVULD 6 mm ONGEHARD, BLANK FLOATGLAS COATING: CLIMA GUARD PREMIUM 2 T 18 mm SPOUW ARGON GEVULD 10.10.4 mm GELAMINEERD HALF GEHARD, BLANK FLOATGLAS</p> <p>TYPE 02: BEGANE GROND ISOLATIEPANEEL 6/16/6/18/10.10.4 6 mm VÖLLEDIG GEHARD, BLANK FLOATGLAS (HEATSOAK- TESTED) COATING: HP 70/35 GUARDIAN 16 mm SPOUW ARGON GEVULD 6 mm ONGEHARD, BLANK FLOATGLAS COATING: CLIMA GUARD PREMIUM 2 T 18 mm SPOUW ARGON GEVULD 10.10.4 mm GELAMINEERD ONGEHARD, BLANK FLOATGLAS</p>	<p><b>VOEGEN:</b> ZWARTE SILICONENKIT BINNENMAAT: TPV TOGGLE 24 +/-2 mm, TPV GLAS ONDERLING 14 +/-2 mm BUITEN MAAT VARIEREND 14-34 mm</p>	<p><b>ZETWERK</b> ALUMINIUM AlMg3, DIKTE 2-3 mm, POEDERCOATEN IN RAL NTB ROESTVAST STAAL AISI 304, DIKTE 2 mm, POEDERCOATEN IN RAL NTB</p>	<p><b>VULPLATEN:</b> SNIJPLAAT SENDZIMR GECOAT, DIKTE 2-5 mm</p>	<p><b>BEVESTIGINGSMODELEN:</b> ZICHTBAAR ROESTVAST STAAL A4-70, OF THERMISCH VERZINKT KWALITEIT 8.8 (VOLGENS NEN-EN 15048-2)</p>	<p><b>CONSERVERING:</b> STAALWERK CONSOLES: THERMISCH VERZINKT (VOLGENS NEN-EN-ISO 1461) STAALWERK L-PROFIELEN: ENKELLAAGS POEDERCOATEN IN RAL NTB ALUMINIUM KLEMLIJSTEN: DUBBELLAAGS POEDERCOATEN IN RAL NTB ALUMINIUM RAAMKOZIJNEN: BINNENZIJDE ENKELLAAGS POEDERCOATEN IN RAL NTB ALUMINIUM RAAMKOZIJNEN: BUITENZIJDE DUBBELLAAGS POEDERCOATEN IN RAL NTB</p>	<p><b>MEMBRANEN:</b> TYPE 01: BINNENZIJDE - EPDM 1.5mm TYPE 02: BUITENZIJDE - EPDM 1.5mm</p>	<p><b>ISOLATIE</b> TYPE 01: PIR, DIKTE 120mm - 140mm</p>	<p><b>UITVOERINGS KLASSE:</b> EXC 2 (VOLGENS NEN-EN 1090-2-A1)</p>
--	--	--	--	--	--	--	--	---	---	--	--	--	--	--	--	--

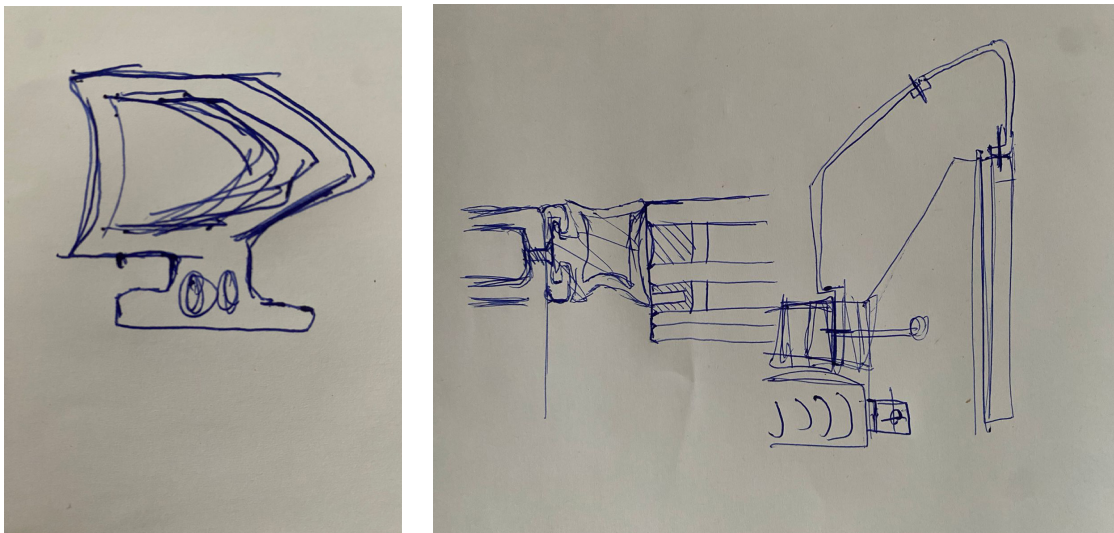




## 10.7 GUTMANN F50++ SSG (TOGGLE)



## 10.8 Improved Design Sketch



## 10.9 Schueco AWS SI Environmental Product Declaration

ERGEBNISSE DER ÖKOBILANZ UMWELTAUSWIRKUNGEN: Schüco AWS 75.SI+ B x H: 1230 mm x 1480 mm						
Parameter	Einheit	A1-A3	A4	B6	C4	D
Globales Erwärmungspotenzial	[kg CO <sub>2</sub> -Äq.]	2,52E+2	5,73E-2	0,00E+0	1,67E+1	-9,27E+1
Abbau Potential der stratosphärischen Ozonschicht	[kg CFC11-Äq.]	5,61E-6	2,63E-13	0,00E+0	4,74E-11	-4,30E-6
Versauerungspotenzial von Boden und Wasser	[kg SO <sub>2</sub> -Äq.]	8,63E-1	1,40E-4	0,00E+0	8,91E-3	-3,58E-1
Eutrophierungspotenzial	[kg (PO <sub>4</sub> ) <sup>3-</sup> -Äq.]	1,09E-1	3,26E-5	0,00E+0	1,41E-3	-2,11E-2
Bildungspotenzial für troposphärisches Ozon	[kg Ethen-Äq.]	8,92E-2	-3,91E-5	0,00E+0	4,00E-4	-2,27E-2
Potenzial für den abiotischen Abbau nicht fossiler Ressourcen	[kg Sb-Äq.]	4,68E-3	3,81E-9	0,00E+0	2,91E-7	-3,43E-3
Potenzial für den abiotischen Abbau fossiler Brennstoffe	[MJ]	3,25E+3	7,88E-1	0,00E+0	4,03E+0	-1,01E+3

ERGEBNISSE DER ÖKOBILANZ RESSOURCENEINSATZ: Schüco AWS 75.SI+ B x H: 1230 mm x 1480 mm						
Parameter	Einheit	A1-A3	A4	B6	C4	D
Erneuerbare Primärenergie als Energieträger	[MJ]	6,11E+2	0,00E+0	0,00E+0	0,00E+0	0,00E+0
Erneuerbare Primärenergie zur stofflichen Nutzung	[MJ]	0,00E+0	0,00E+0	0,00E+0	0,00E+0	0,00E+0
Total erneuerbare Primärenergie	[MJ]	6,11E+2	4,48E-2	0,00E+0	5,00E-1	-3,94E+2
Nicht-erneuerbare Primärenergie als Energieträger	[MJ]	3,45E+3	0,00E+0	0,00E+0	0,00E+0	0,00E+0
Nicht-erneuerbare Primärenergie zur stofflichen Nutzung	[MJ]	2,87E+2	0,00E+0	0,00E+0	0,00E+0	0,00E+0
Total nicht erneuerbare Primärenergie	[MJ]	3,74E+3	7,91E-1	0,00E+0	4,55E+0	-1,32E+3
Einsatz von Sekundärstoffen	[kg]	7,47E+0	0,00E+0	0,00E+0	0,00E+0	0,00E+0
Erneuerbare Sekundärrohstoffe	[MJ]	0,00E+0	0,00E+0	0,00E+0	0,00E+0	0,00E+0
Nicht-erneuerbare Sekundärrohstoffe	[MJ]	0,00E+0	0,00E+0	0,00E+0	0,00E+0	0,00E+0
Einsatz von Süßwasserressourcen	[m <sup>3</sup> ]	1,36E+0	1,12E-4	0,00E+0	4,19E-2	-8,02E-1

ERGEBNISSE DER ÖKOBILANZ OUTPUT-FLÜSSE UND ABFALLKATEGORIEN: Schüco AWS 75.SI+ B x H: 1230 mm x 1480 mm						
Parameter	Einheit	A1-A3	A4	B6	C4	D
Gefährlicher Abfall zur Deponie	[kg]	1,71E-4	5,98E-8	0,00E+0	1,99E-8	-2,52E-5
Entsorgter nicht gefährlicher Abfall	[kg]	3,34E+1	6,65E-5	0,00E+0	1,73E+0	-2,01E+1
Entsorgter radioaktiver Abfall	[kg]	2,01E-1	1,13E-6	0,00E+0	2,07E-4	-1,29E-1
Komponenten für die Wiederverwendung	[kg]	0,00E+0	0,00E+0	0,00E+0	0,00E+0	0,00E+0
Stoffe zum Recycling	[kg]	0,00E+0	0,00E+0	0,00E+0	0,00E+0	6,46E+1
Stoffe für die Energierückgewinnung	[kg]	0,00E+0	0,00E+0	0,00E+0	0,00E+0	0,00E+0
Exportierte elektrische Energie	[MJ]	0,00E+0	0,00E+0	0,00E+0	3,23E+1	0,00E+0
Exportierte thermische Energie	[MJ]	0,00E+0	0,00E+0	0,00E+0	7,46E+1	0,00E+0

## 10.10 Euroglass Rosenheim EPD

Results per 1 m <sup>2</sup> and 1 mm of FG, TSG, LSG (Part 1)	Unit	Flat glass				Toughened safety glass				Laminated safety glass			
		A1-A3	C3	C4	D	A1-A3	C3	C4	D	A1-A3	C3	C4	D
Global warming potential (GWP)	kg CO <sub>2</sub> equiv.	2,43	4,32E-02	2,79E-02	-0,39	3,46	4,32E-02	2,79E-02	-0,39	7,93	4,28E-02	2,88E-02	-0,39
Depletion potential of stratospheric layer (ODP)	kg R11 equiv.	7,23E-13	1,92E-13	6,32E-15	-2,27E-13	5,12E-12	1,92E-13	6,32E-15	-2,27E-13	7,60E-09	1,90E-13	6,53E-15	-2,25E-13
Acidification potential of soil and water (AP)	kg CO <sub>2</sub> equiv.	1,43E-02	1,23E-04	1,65E-04	-2,13E-03	3,25E-02	1,23E-04	1,65E-04	-2,13E-03	4,91E-02	1,22E-04	1,70E-04	-2,11E-03
Eutrophication potential (EP)	kg PO <sub>4</sub> <sup>3-</sup> equiv.	1,49E-03	1,15E-05	2,28E-05	-2,74E-04	2,83E-03	1,15E-05	2,28E-05	-2,74E-04	4,26E-03	1,14E-05	2,35E-05	-2,71E-04
Formation potential of tropospheric ozone (POCP)	kg C <sub>2</sub> H <sub>4</sub> equiv.	8,18E-04	7,68E-06	1,28E-05	2,98E-04	1,70E-03	7,68E-06	1,28E-05	2,98E-04	2,93E-03	7,61E-06	1,32E-05	2,96E-04
Abiotic depletion potential - non-fossil resources (ADP - elements)	kg Sb equiv.	2,24E-05	2,30E-08	1,07E-08	-8,43E-07	2,35E-05	2,30E-08	1,07E-08	-8,43E-07	6,08E-05	2,28E-08	1,10E-08	-8,36E-07
Abiotic depletion potential - fossil fuels (ADP - fossil resources)	MJ	44,37	0,46	0,36	-5,29	55,63	0,46	0,36	-5,29	106,95	0,46	0,37	-5,24
<b>Use of resources</b>	<b>Unit</b>	<b>A1-A3</b>	<b>C3</b>	<b>C4</b>	<b>D</b>	<b>A1-A3</b>	<b>C3</b>	<b>C4</b>	<b>D</b>	<b>A1-A3</b>	<b>C3</b>	<b>C4</b>	<b>D</b>
Use of renewable primary energy - excluding renewable primary energy resources used as raw materials	MJ	0,60	-	-	-	7,39	-	-	-	30,73	-	-	-
Use of renewable primary energy resources used as raw materials (material use)	MJ	0,00	-	-	-	0,00	-	-	-	0,00	-	-	-
Total use of renewable primary energy resources (primary energy and renewable primary energy resources used as raw materials) (energy + material use)	MJ	0,60	0,30	4,63E-02	-0,38	7,39	0,30	4,63E-02	-0,38	30,73	0,29	4,78E-02	-0,38
Use of non-renewable primary energy excluding non-renewable primary energy resources used as raw materials	MJ	44,80	-	-	-	63,59	-	-	-	139,77	-	-	-
Use of non-renewable primary energy resources used as raw materials (material use)	MJ	0,00	-	-	-	0,00	-	-	-	1,44	-	-	-
Total use of non-renewable primary energy resources (primary energy and non-renewable primary energy resources used as raw materials) (energy + material use)	MJ	44,80	0,79	0,37	-5,69	63,59	0,79	0,37	-5,69	141,21	0,78	3,86E-01	-5,64
Use of secondary materials	kg	0,10	0,00	0,00	0,00	0,10	0,00	0,00	0,00	0,12	0,00	0,00	0,00

## 10.11 Partial Calculations

### virgin feedstock (V)

element ID	element name	material	mass (M)	fraction recycled (Fr)	fraction reused (Fu)	virgin feedstock (V)
T01_S	transom silicone seal	silicone	1,05	0	0	1,05
T01_TA	transom toggle	aluminium 6060	0,30	0,49	0	0,153
T01_G	transom gasket	aluminium 6060	1,26	0	0	1,26
T01_P	transom profile	aluminium 6060	0,60	0,49	0	0,306
IGU_LG	laminated glass	float glass + pvb	32,40	0,1	0	29,16
IGU_BS	butyl seal	isobutylene	0,01	0	0	0,01
IGU_SP	thermobar spacer	aluminium	0,40	0,49	0	0,204
IGU_TG	tempered glass	low-e glass	12,70	0,1	0	11,43
IGU_SP	thermobar spacer	aluminium	0,40	0,49	0	0,204
IGU_TG	tempered glass	low-e glass	12,70	0,1	0	11,43
IGU_SS	silicone seal	silicone	2,05	0	0	2,05

### waste to landfill (Wo)

element ID	element name	material	mass (M)	fraction recycling (Cr)	fraction reuse (Cu)	waste landfill (Wo)
T01_S	transom silicone seal	silicone	1,05	0	0	1,05
T01_TA	transom toggle	aluminium 6060	0,30	1	0	0
T01_G	transom gasket	aluminium 6060	1,26	0	0	1,26
T01_P	transom profile	aluminium 6060	0,60	1	0	0
IGU_LG	laminated glass	float glass + pvb	32,40	1	0	0
IGU_BS	butyl seal	isobutylene	0,01	0	0	0,01
IGU_SP	thermobar spacer	aluminium	0,40	1	0	0
IGU_TG	tempered glass	low-e glass	12,70	1	0	0
IGU_SP	thermobar spacer	aluminium	0,40	1	0	0
IGU_TG	tempered glass	low-e glass	12,70	1	0	0
IGU_SS	silicone seal	silicone	2,05	0	0	2,05

### waste from recycling (Wc)

element ID	element name	material	mass (M)	efficiency recycle (Ec)	fraction recycling (Cr)	waste recycling (Wc)
T01_S	transom silicone seal	silicone	1,05	0	0	0
T01_TA	transom toggle	aluminium 6060	0,30	0,92	1	0,024
T01_G	transom gasket	aluminium 6060	1,26	0	0	0
T01_P	transom profile	aluminium 6060	0,60	0,92	1	0,048
IGU_LG	laminated glass	float glass + pvb	32,40	0,4	1	19,44
IGU_BS	butyl seal	isobutylene	0,01	0	0	0
IGU_SP	thermobar spacer	aluminium	0,40	0,92	1	0,032
IGU_TG	tempered glass	low-e glass	12,70	0,4	1	7,62
IGU_SP	thermobar spacer	aluminium	0,40	0,92	1	0,032
IGU_TG	tempered glass	low-e glass	12,70	0,4	1	7,62
IGU_SS	silicone seal	silicone	2,05	0	0	0

### waste feedstock (Wf)

element ID	element name	material	mass (M)	efficiency feed (Ef)	fraction recycled (Fr)	waste feedstock (Wf)
T01_S	transom silicone seal	silicone	1,05	1	0	0,00
T01_TA	transom toggle	aluminium 6060	0,30	0,98	0,49	0,00
T01_G	transom gasket	aluminium 6060	1,26	1	0	0,00
T01_P	transom profile	aluminium 6060	0,60	0,98	0,49	0,01
IGU_LG	laminated glass	float glass + pvb	32,40	0,9	0,1	0,36
IGU_BS	butyl seal	isobutylene	0,01	1	0	0,00
IGU_SP	thermobar spacer	aluminium	0,40	0,98	0,49	0,00
IGU_TG	tempered glass	low-e glass	12,70	0,9	0,1	0,14
IGU_SP	thermobar spacer	aluminium	0,40	0,98	0,49	0,00
IGU_TG	tempered glass	low-e glass	12,70	0,9	0,1	0,14
IGU_SS	silicone seal	silicone	2,05	1	0	0,00



unrecoverable waste (W)

element ID	element name	material	landfill (Wo)	waste recycling (Wc)	waste feedstock (Wf)	unrecoverable (W)
T01_S	transom silicone seal	silicone	1,05	0,00	0,00	1,05
T01_TA	transom toggle	aluminium 6060	0,00	0,02	0,00	0,01
T01_G	transom gasket	aluminium 6060	1,26	0,00	0,00	1,26
T01_P	transom profile	aluminium 6060	0,00	0,05	0,01	0,03
IGU_LG	laminated glass	float glass + pvb	0,00	19,44	0,36	9,90
IGU_BS	butyl seal	isobutylene	0,01	0,00	0,00	0,01
IGU_SP	thermobar spacer	aluminium	0,00	0,03	0,00	0,02
IGU_TG	tempered glass	low-e glass	0,00	7,62	0,14	3,88
IGU_SP	thermobar spacer	aluminium	0,00	0,03	0,00	0,02
IGU_TG	tempered glass	low-e glass	0,00	7,62	0,14	3,88
IGU_SS	silicone seal	silicone	2,05	0,00	0,00	2,05

linear flow index (LFI)

element ID	element name	material	mass (M)	virgin feedstock (V)	unrecoverable (W)	LFI
T01_S	transom silicone seal	silicone	1,05	1,05	1,05	1,0
T01_TA	transom toggle	aluminium 6060	0,30	0,15	0,01	0,3
T01_G	transom gasket	aluminium 6060	1,26	1,26	1,26	1,0
T01_P	transom profile	aluminium 6060	0,60	0,31	0,03	0,3
IGU_LG	laminated glass	float glass + pvb	32,40	29,16	9,90	0,6
IGU_BS	butyl seal	isobutylene	0,01	0,01	0,01	1,0
IGU_SP	thermobar spacer	aluminium	0,40	0,20	0,02	0,3
IGU_TG	tempered glass	low-e glass	12,70	11,43	3,88	0,6
IGU_SP	thermobar spacer	aluminium	0,40	0,20	0,02	0,3
IGU_TG	tempered glass	low-e glass	12,70	11,43	3,88	0,6
IGU_SS	silicone seal	silicone	2,05	2,05	2,05	1,0

utility factor (Fx)

element ID	element name	material	declared lifespan (L)	industry (Lav)	factor (X)	utility factor F(x)
T01_S	transom silicone seal	silicone	25	25	1,0	0,9
T01_TA	transom toggle	aluminium 6060	60	75	0,8	1,1
T01_G	transom gasket	aluminium 6060	25	25	1,0	0,9
T01_P	transom profile	aluminium 6060	60	75	0,8	1,1
IGU_LG	laminated glass	float glass + pvb	30	30	1,0	0,9
IGU_BS	butyl seal	isobutylene	30	30	1,0	0,9
IGU_SP	thermobar spacer	aluminium	30	30	1,0	0,9
IGU_TG	tempered glass	low-e glass	30	30	1,0	0,9
IGU_SP	thermobar spacer	aluminium	30	30	1,0	0,9
IGU_TG	tempered glass	low-e glass	30	30	1,0	0,9
IGU_SS	silicone seal	silicone	25	25	1,0	0,9

material circularity (MCI)

element ID	element name	material	mass (M)	linear flow index (LFI)	utility factor F(x)	MCI
T01_S	transom silicone seal	silicone	1,05	1,0	0,9	0,1
T01_TA	transom toggle	aluminium 6060	0,30	0,3	1,1	0,7
T01_G	transom gasket	aluminium 6060	1,26	1,0	0,9	0,1
T01_P	transom profile	aluminium 6060	0,60	0,3	1,1	0,7
IGU_LG	laminated glass	float glass + pvb	32,40	0,6	0,9	0,5
IGU_BS	butyl seal	isobutylene	0,01	1,0	0,9	0,1
IGU_SP	thermobar spacer	aluminium	0,40	0,3	0,9	0,8
IGU_TG	tempered glass	low-e glass	12,70	0,6	0,9	0,5
IGU_SP	thermobar spacer	aluminium	0,40	0,3	0,9	0,8
IGU_TG	tempered glass	low-e glass	12,70	0,6	0,9	0,5
IGU_SS	silicone seal	silicone	2,05	1,0	0,9	0,1

connection disassembly (DPc)

element ID	element name	material	Connection Type (CT)	CT	Accessibility (CA)	CA	DPc
T01_S	transom silicone seal	silicone	adhesive	0,1	damage	0,1	0,1
T01_TA	transom toggle	aluminium 6060	screw fixing	0,8	accessible with actions	0,8	0,8
T01_G	transom gasket	aluminium 6060	screw fixing	0,8	accessible with actions	0,8	0,8
T01_P	transom profile	aluminium 6060	bolted with elements	0,8	accessible with actions	0,8	0,8
IGU	insulated glass unit	mixed	connection with elements	0,8	accessible with actions	0,8	0,8
IGU_LG	laminated glass	float glass + pvb	adhesive	0,1	accessible, partial repair	0,4	0,2
IGU_BS	butyl seal	isobutylene	adhesive	0,1	damage	0,1	0,1
IGU_SP	thermobar spacer	aluminium	adhesive	0,1	accessible, partial repair	0,4	0,2
IGU_TG	tempered glass	low-e glass	adhesive	0,1	accessible, partial repair	0,4	0,2
IGU_SP	thermobar spacer	aluminium	adhesive	0,1	accessible, partial repair	0,4	0,2
IGU_TG	tempered glass	low-e glass	adhesive	0,1	accessible, partial repair	0,4	0,2
IGU_SS	silicone seal	silicone	adhesive	0,1	damage	0,1	0,1

composition disassembly (DPcp)

element ID	element name	material	Independency (ID)	ID	Edge Geometry (GPE)	GPE	DPc
T01_S	transom silicone seal	silicone	modular zoning	1	closed	1	1,0
T01_TA	transom toggle	aluminium 6060	modular zoning	1	overlapping	0,4	0,6
T01_G	transom gasket	aluminium 6060	occasional zoning	1	overlapping	0,4	0,6
T01_P	transom profile	aluminium 6060	modular zoning	1	overlapping	0,4	0,6
IGU	insulated glass unit	mixed	modular zoning	1	open	1	1,0
IGU_LG	laminated glass	float glass + pvb	full integration	0,1	closed	0,1	0,1
IGU_BS	butyl seal	isobutylene	full integration	0,1	closed	0,1	0,1
IGU_SP	thermobar spacer	aluminium	full integration	0,1	closed	0,1	0,1
IGU_TG	tempered glass	low-e glass	full integration	0,1	closed	0,1	0,1
IGU_SP	thermobar spacer	aluminium	full integration	0,1	closed	0,1	0,1
IGU_TG	tempered glass	low-e glass	full integration	0,1	closed	0,1	0,1
IGU_SS	silicone seal	silicone	full integration	0,1	closed	0,1	0,1

product disassembly (DPp)

element ID	element name	material	CT	CA	ID	GPE	DPp
T01_S	transom silicone seal	silicone	0,1	0,1	1	1	0,2
T01_TA	transom toggle	aluminium 6060	0,8	0,8	1	0,4	0,7
T01_G	transom gasket	aluminium 6060	0,8	0,8	1	0,4	0,7
T01_P	transom profile	aluminium 6060	0,8	0,8	1	0,4	0,7
IGU	insulated glass unit	mixed	0,8	0,8	1	1	0,9
IGU_LG	laminated glass	float glass + pvb	0,1	0,4	0,1	0,1	0,1
IGU_BS	butyl seal	isobutylene	0,1	0,1	0,1	0,1	0,1
IGU_SP	thermobar spacer	aluminium	0,1	0,4	0,1	0,1	0,1
IGU_TG	tempered glass	low-e glass	0,1	0,4	0,1	0,1	0,1
IGU_SP	thermobar spacer	aluminium	0,1	0,4	0,1	0,1	0,1
IGU_TG	tempered glass	low-e glass	0,1	0,4	0,1	0,1	0,1
IGU_SS	silicone seal	silicone	0,1	0,1	0,1	0,1	0,1

# 10.12 User Interface Demonstration

Design Phase
EoL Phase

L1\_Material
L2\_Element
L3\_Subcomponent
L4\_Component
L5\_Subsystem
L6\_System
L7\_Building

**Input**

ID DOU\_LG

Common Name Laminated Glass

Connection Type

Connection Accessibility

Independence

Geometry Product Edge

**Disassembly Map**

**Output**

Connection Type (CT)  
 Connection Accessibility (CA)  
 Independence (ID)  
 Geometry of Product Edge (GPE)  
 Disassembly Potential (DPP)

Design Phase
EoL Phase

L1\_Material
L2\_Element
L3\_Subcomponent
L4\_Component
L5\_Subsystem
L6\_System
L7\_Building

**Input**

ID DOU\_LG

Common Name Laminated Glass

Amount of Connectors

Number of Manipulations

Visibility

Tool Type Cut

**Disassembly Map**

**Output**

**disassembly time:**  
21,1 s

Design Phase
EoL Phase

L1\_Material
L2\_Element
L3\_Subcomponent
L4\_Component
L5\_Subsystem
L6\_System
L7\_Building

**Input**

threshold (0,6) for reusability  
(according to BCI)

**Disassembly Map**

**Output**

connection disassembly failure for reuse