

Mediating Religious Elements

Transforming the Saint Augustinus Church

Manual of Construction

A Community Build Strategy

AR3AH115 Revitalizing Heritage: Zero Waste Church

Tanishka Sarma
5484804

Table of Contents

Stage	Page
Bringing together the community	8
Preparation of the building	10
Connections through Demolition	14
Harvesting and storage	20
Use of the rectory and creating the Fabrication Lab	24
Insulating the skin	28
Fabrication of Components	38
Assembling the workspaces	44
Adding circulation	56
Adding Storage	62
Creating the Stage	66
Creating the Communal Zones	70
Rentable Individual Studios	76
The Exhibition in the Attic and the Tower	80

This is a manual for the construction process of the saint augustinus church in Amsterdam-Noord. It outlines the methods to achieve the final product. This is a phased project with varying amounts of volunteering required by members of the community of the church. Here the community is defined as the people who are closely linked to the church in the past or would like to be associated with it in the future.

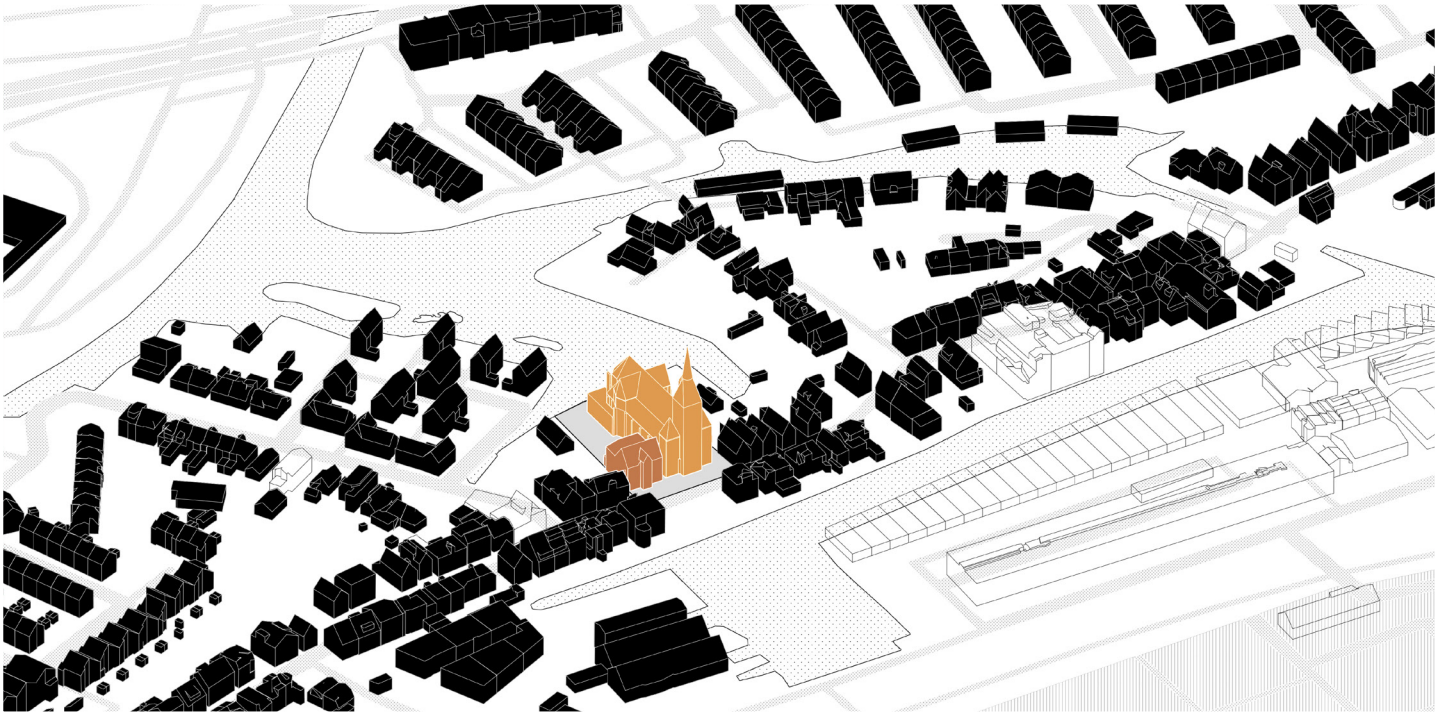

Overview of the Process

Creating a
construction and
assembly group

Demolition
+
Harvesting

Storage of
elements

+

Storage of
material
harvested through
demolition

Fabrication

Workshops

Storage
Spaces

Metal

Wood

Restoration — Stained glass
— Bell
— Altar
— Furniture
— Wall

Insulation — Creating a closed
— climate controlled
— space

Assembly ← Harvested material or
— Bio-based material used

Financially-Viable
— programs

Services — Co-working spaces — Art workshops — community kitchen

— Tower exhibition
— Exhibition spaces
Cultural Programmes

Building use —
— Once the building reaches
— a stage of financial
— stability

Bringing together the community

Construction Crew:

The group focused on construction will be made of volunteers who have a prior knowledge of construction techniques and means of demolition and harvesting. They will help from stage 1 to 3.

Managerial crew:

This group will be made of people who will maintain and update construction timelines, material storage and keep and account of all volunteers

Fabrication Crew:

This group will work in the fabrication lab in the rectory and work with metal and timber element harvested from the church. They will be formed of people who have knowledge of equipment in wood and metal workshops who will then teach the other volunteers how to use the equipment. They will together create the various design elements in the church.

Assembly Crew:

This group will be brought in at stage 5 to assemble and put together the element created by the fabrication crew. Their work will be concentrated in the church and focus mainly on connecting the elements to form the whole usable space.

Preparation of the building

Motive:

To prepare the church and rectory for demolition and construction. This is done to from a clean slate that can then be manipulated for the final design.

How-to:

The furniture is collected and stored in the rectory for future use. All non load bearing and partition wall are removed and collected too. Doors and windows are also removed from their frames and collected. Windows are removed from the stone frames and stained glass windows are sent for conservation. Frosted glass windows are stored for future use.

Undertaken by:

The De-Construction Crew

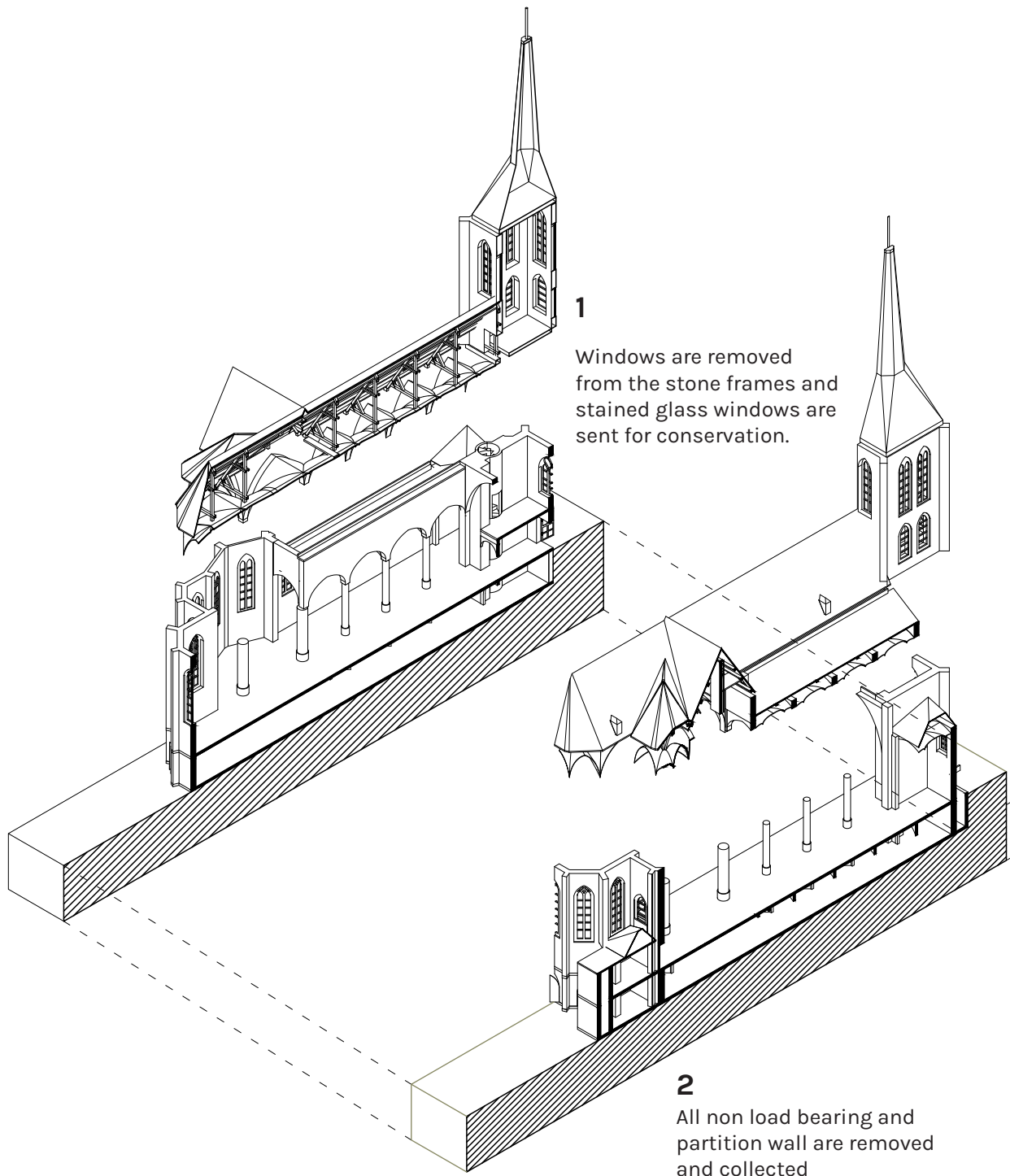

Stage 1:
Preparation of the Building
Undertaken by:
The De-Construction Crew

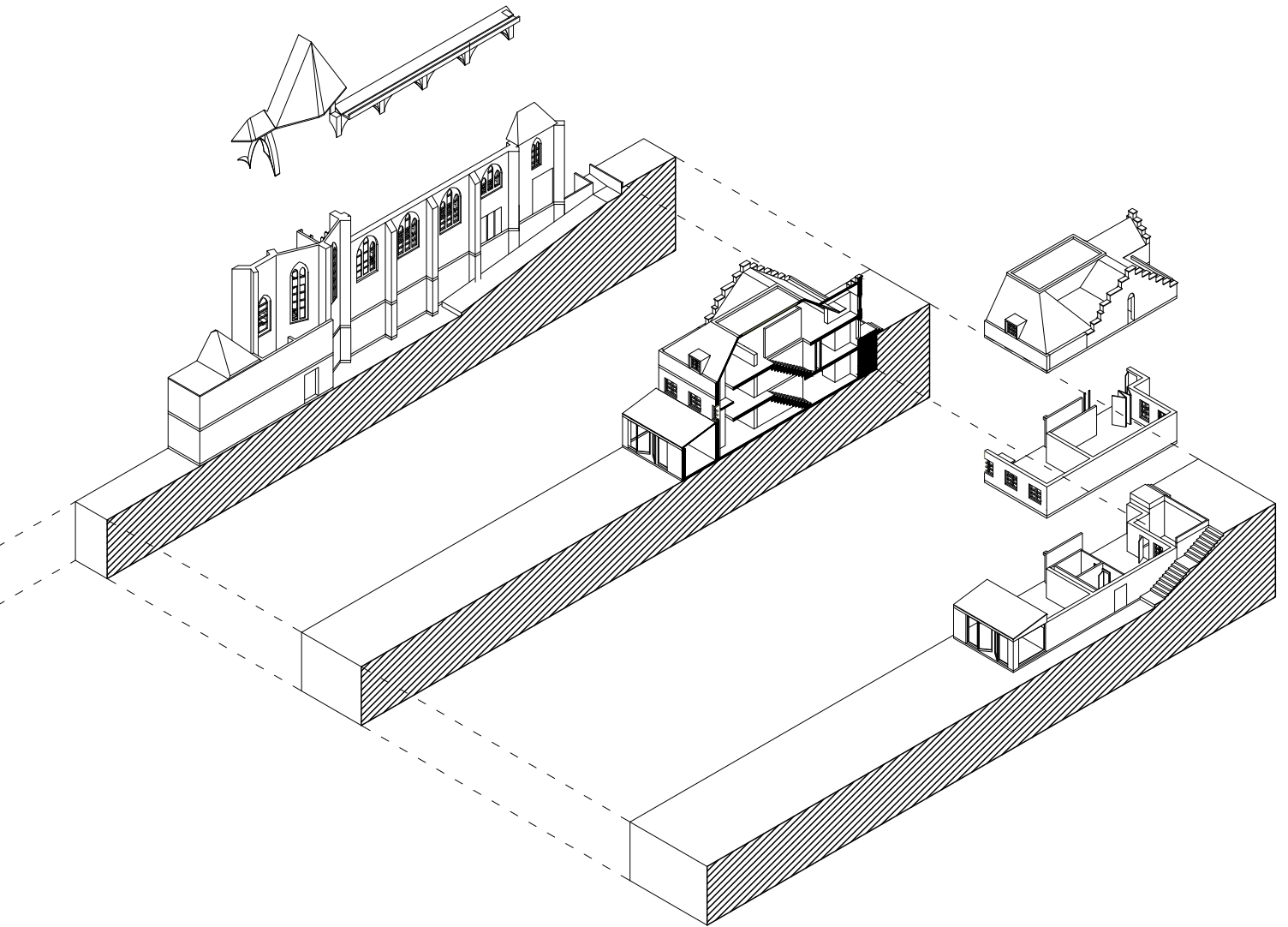

3

The furniture is collected and stored in the rectory for future use.

4

Everything in storage is cataloged for use in the construction process or in the future in the fabrication lab

Connections through Demolition

Motive:

The church is isolated as it was a space for sacred introspection but now has to be made open to the community. The physical isolation is broken by the creation of cut out in the church elevation.

How-to:

The altar is removed and a through and through cut, from the entrance to the other side of the church is made. Connection to the surroundings is achieved by cutting through the profile of the window and down the wall for permeability of light and a visual connection to the outside. Other smaller cuts on the floor are made for vertical circulation shafts.

Undertaken by:

The De-Construction Crew

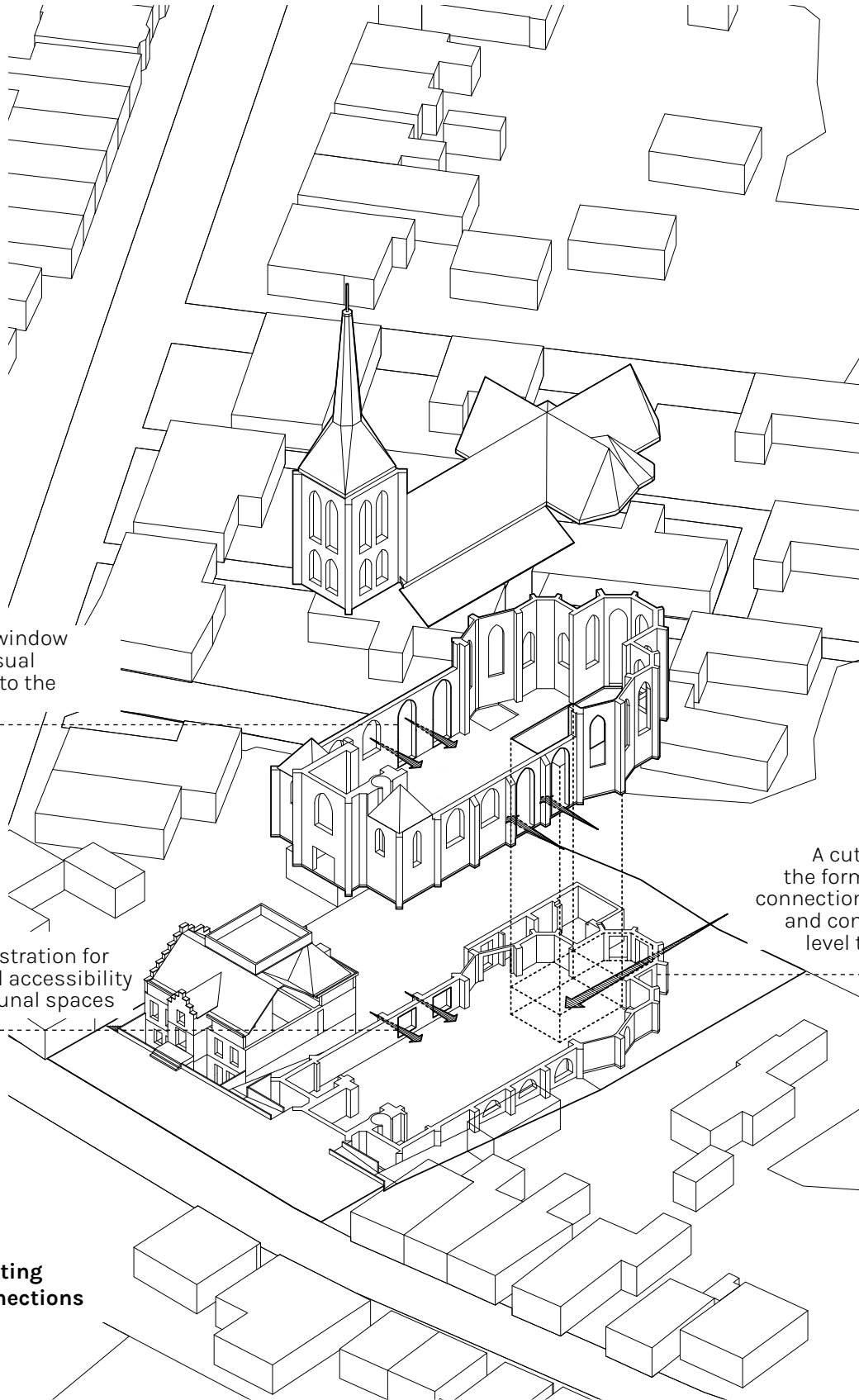

1
Extending the window
for light and visual
accessibility into the
workshops

2
Creating a fenestration for
light and visual accessibility
into the communal spaces

3
A cutout in the floor for
the formation of a vertical
connection to the lower body
and connecting the upper
level to the ground floor

**Creating
Connections**

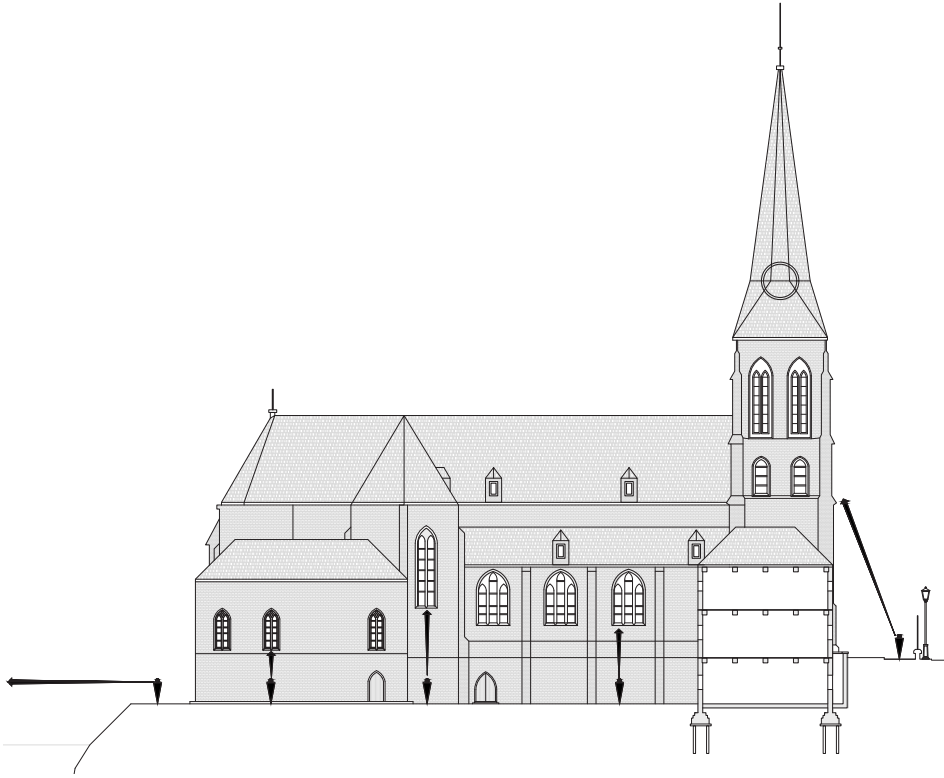

Originally, the church remains isolated from its surroundings

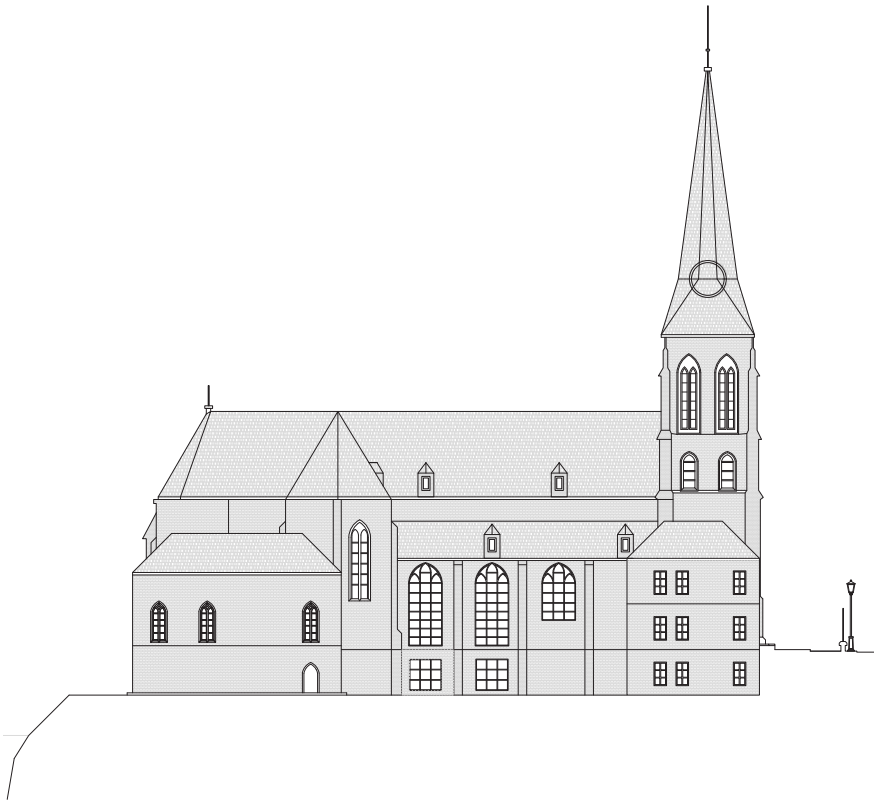

Creating cut out in the elevation allows the otherwise isolated church interiors to be connected to the surroundings

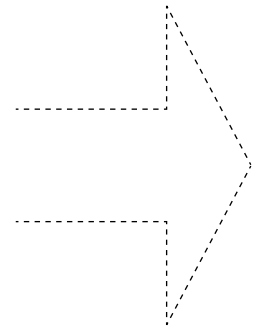
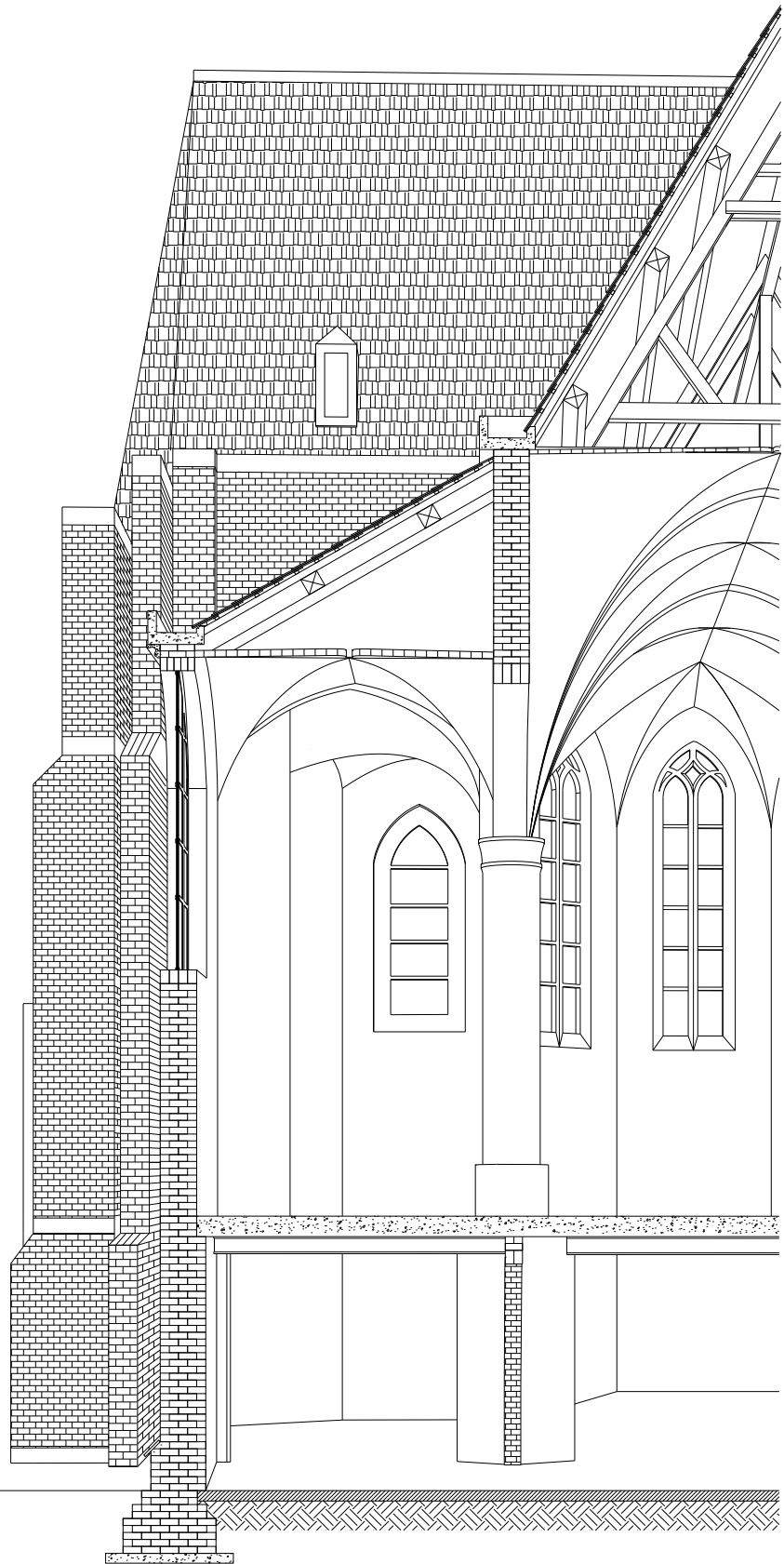

Original
Condition

1
Create the connections to the surroundings

2
Send each glass panel for restoration and then stored in the rectory until reinstallation

3
Introduce structural support wherever needed using harvested I-Beams

Creating Connections

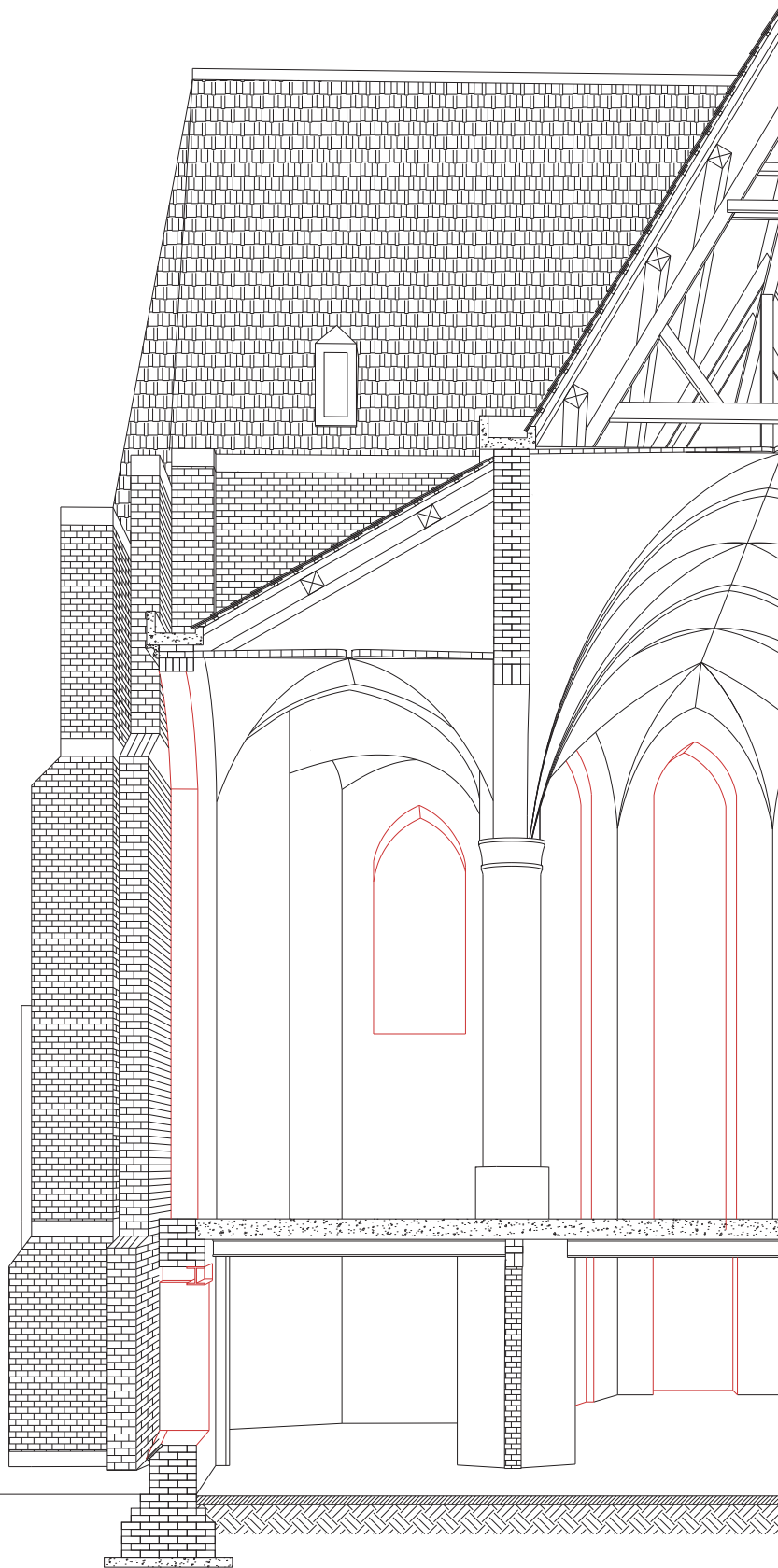

Harvesting and storage

Motive:

Circularity in the built environment is to a large part the prime motive behind the conversion of the church. This is done by harvesting any material from the church and rectory and using it in the construction process or stored for future use in an allocated location where it can be utilized in the workshops by craftsmen and artists or for use in other construction projects.

How-to:

This begins with the careful removal of the elements and their storage. The first and second floor of the rectory are used for this purpose. Brick walls are cut into size and stored for future use. Timber doors are broken down and stored alongside timber furniture. Stained glass windows are also stored here until their installment

Undertaken by:

The De-Construction Crew

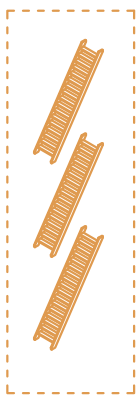
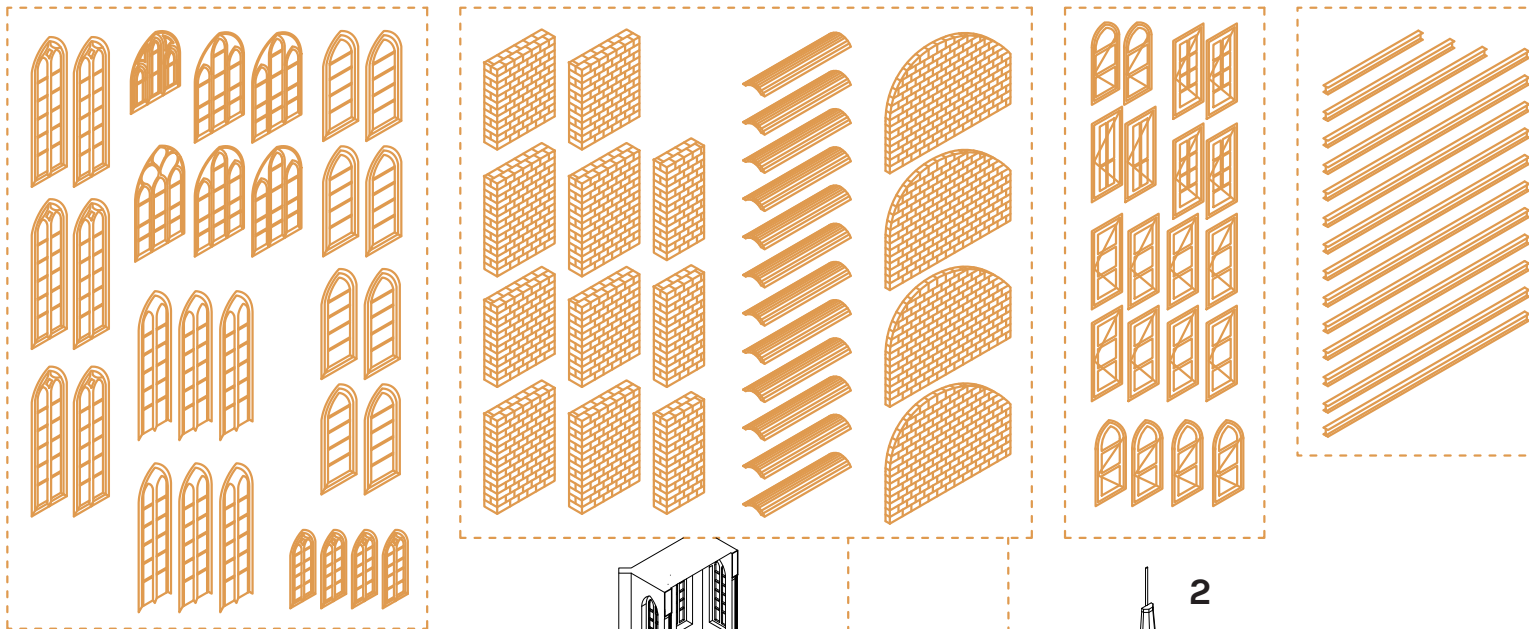

1
All staircases and ladders are dismantled and stored in pieces

2
H and I-beams from the floor are stored for future use

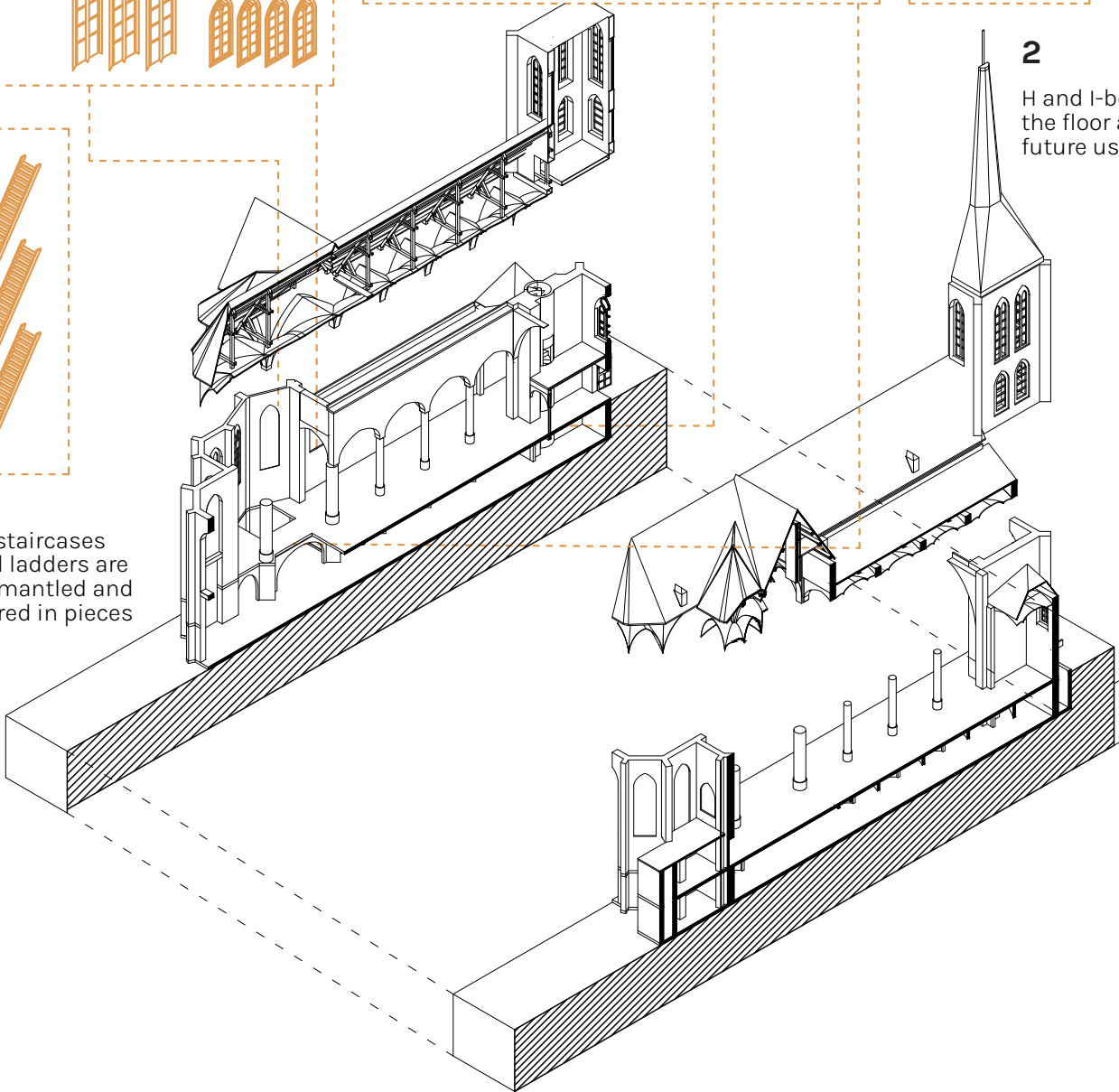

Stage 4:
Harvesting and storage
Undertaken by:
The De-Construction Crew

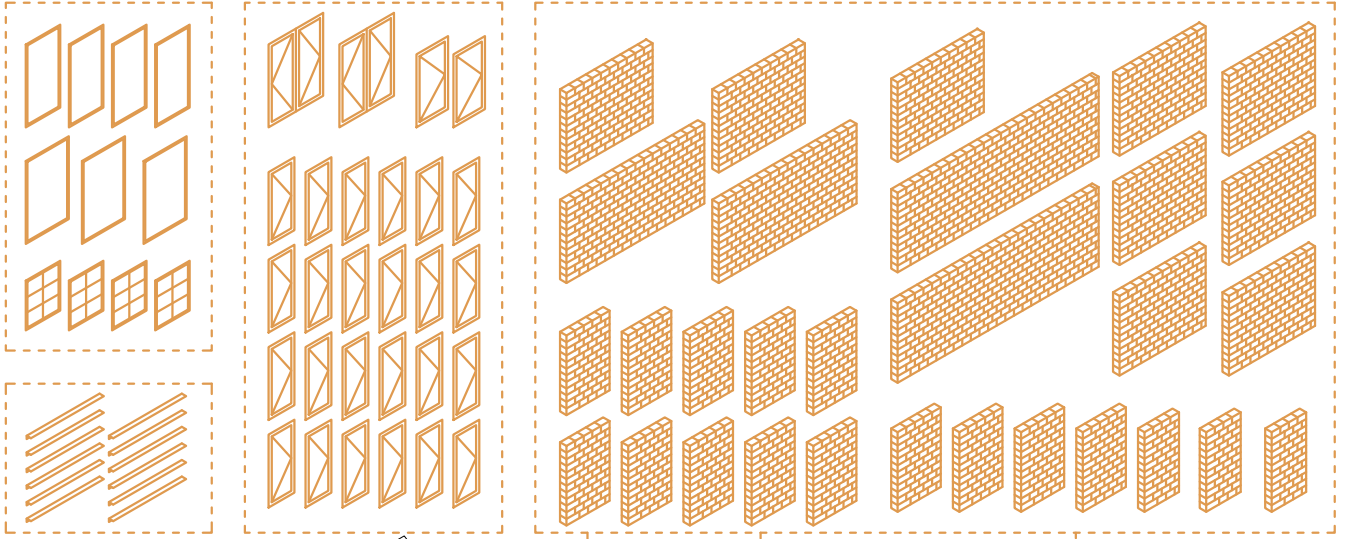

3
Brick walls are cut
into 2 meter sections
and stored in the
rectory

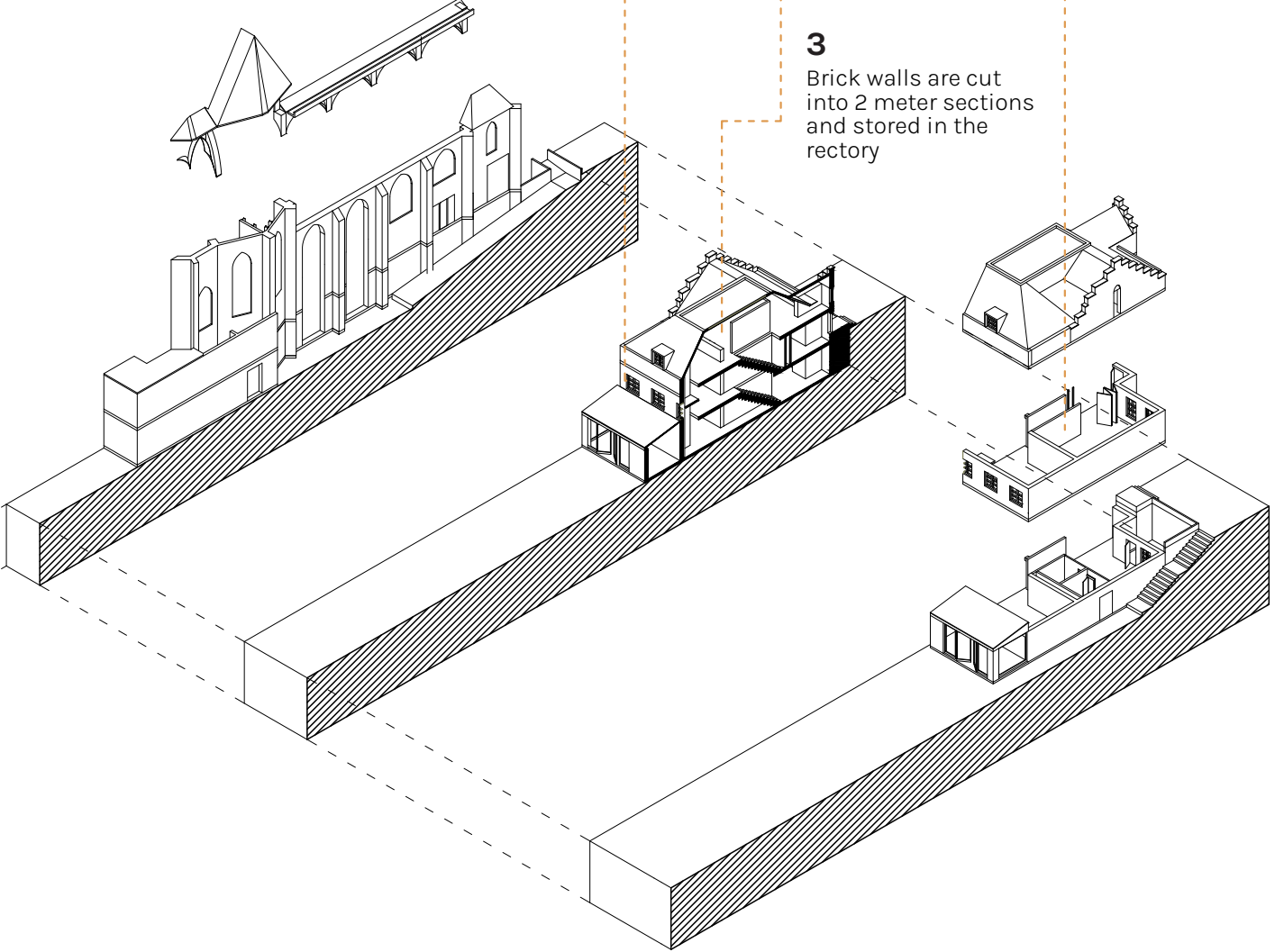

Use of the rectory and creating the Fabrication Lab

Motive:

The church is created as the communal creative zone and the rectory is used during the construction process for storage of materials and elements and as a fabrication space. This fabrication space is broken into two areas, a work area and a zone with equipment where people can work to create the interventions inside the church. This is also where more experienced member of the community would teach the other how to use the equipment before the construction process is taken up.

How-to:

The ground floor of the rectory is converted into the fabrication room and the first and second floor are converted into storage spaces.

Undertaken by:

The De-Construction Crew

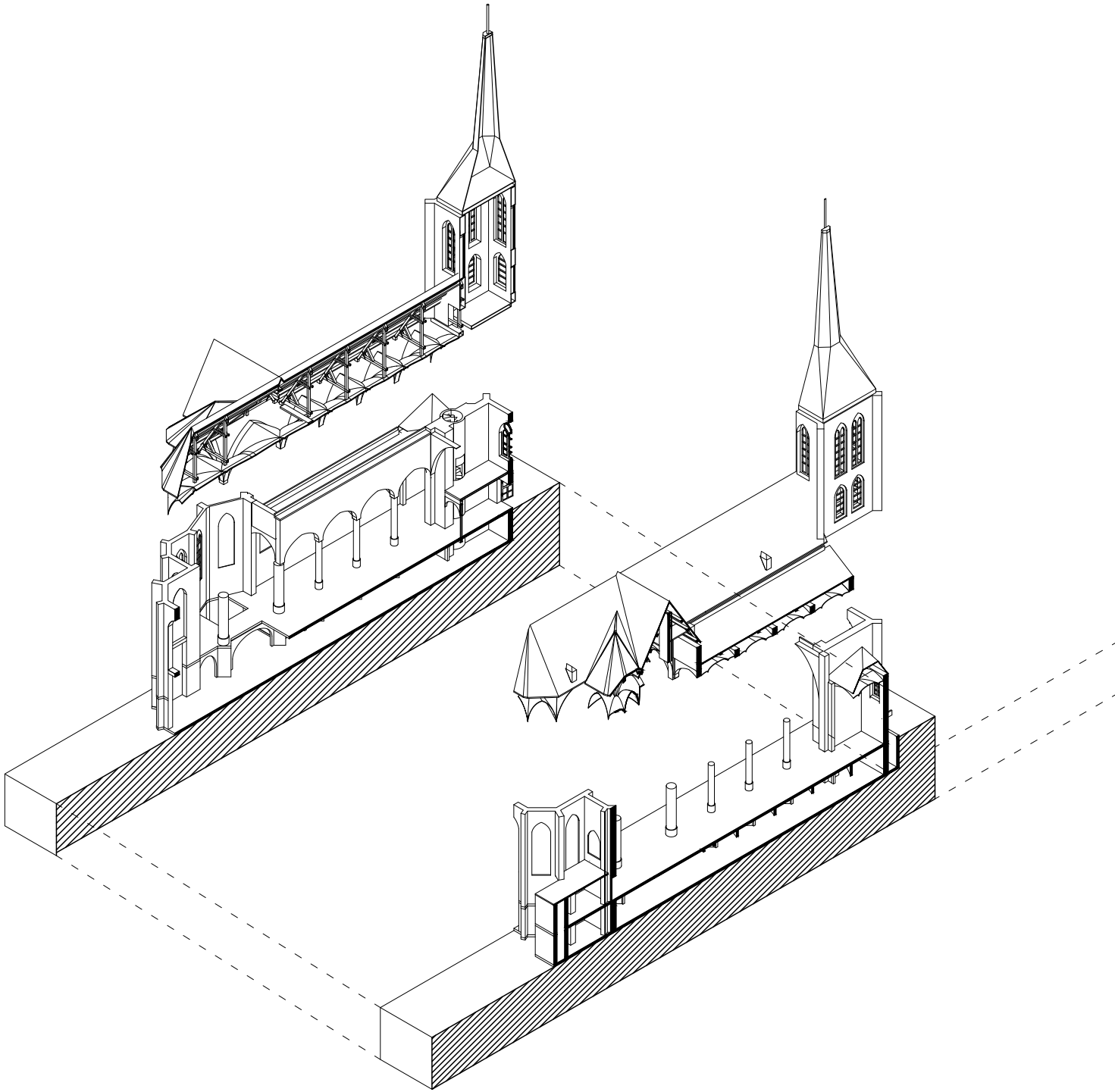

Stage 5:
Use of the rectory
Undertaken by:
The De-Construction Crew

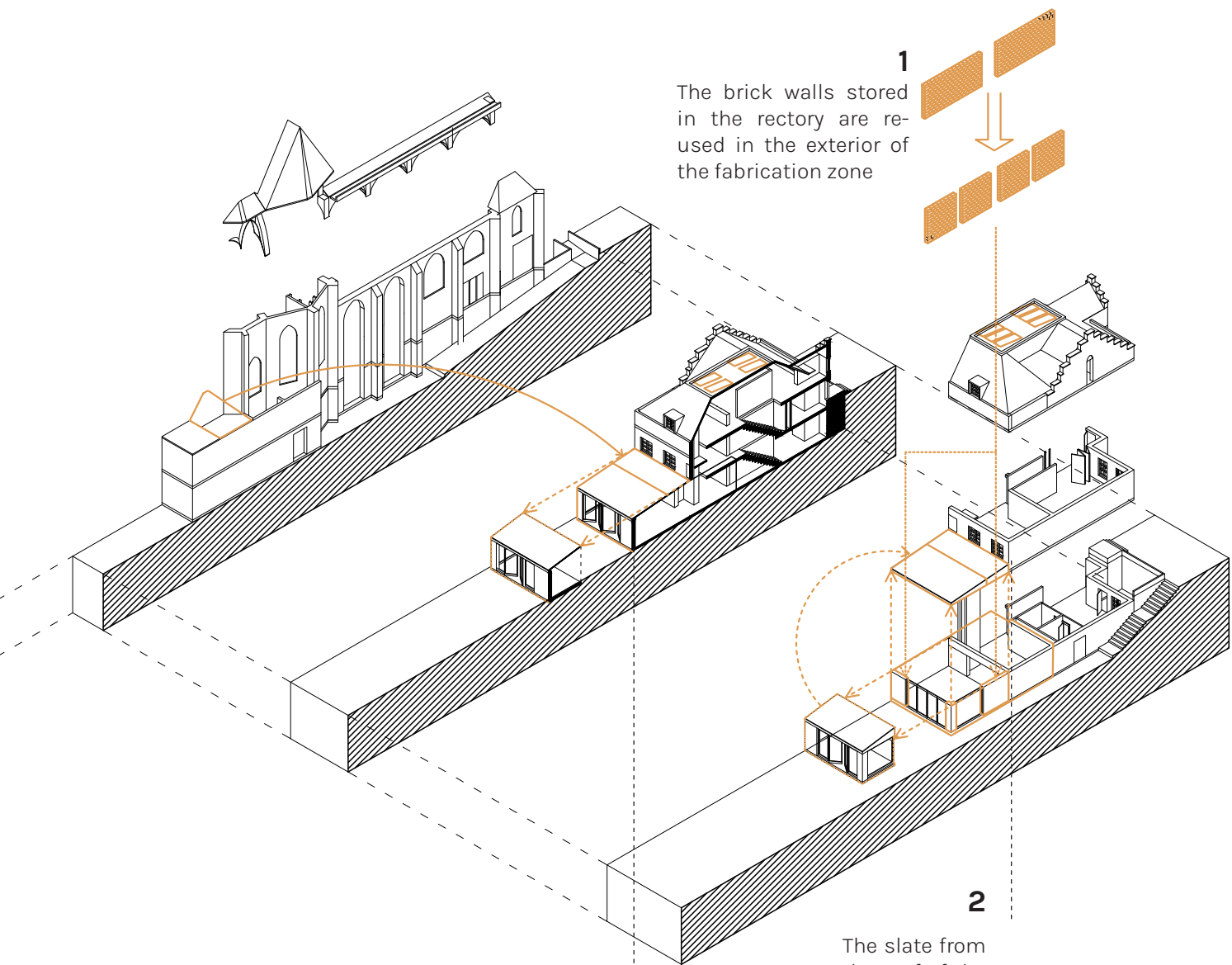

1
The brick walls stored in the rectory are re-used in the exterior of the fabrication zone

1
The rectory is converted into a fabrication space on the ground floor. This is then used for the construction of all units for the design.

2
The slate from the roof of the pastor's room is used in the extension

Insulating the skin

Motive:

The church is a currently cold uninsulated space and this can be countered by the introduction of new windows. These windows are necessary for two reasons, first, assessment of the existing windows shows that they are warping from years of neglect and second, most windows are frosted and don't let direct sunlight into the church and makes the interiors damp and moldy. Moreover, areas like the vaults are uninsulated.

How-to:

First, the windows are replaced with double insulated glazing units and then the roof is insulated with hemp wool panels. These involve bringing in new material from suppliers which will be coordinated by the architect and the managerial.

Undertaken by:

The Construction Crew

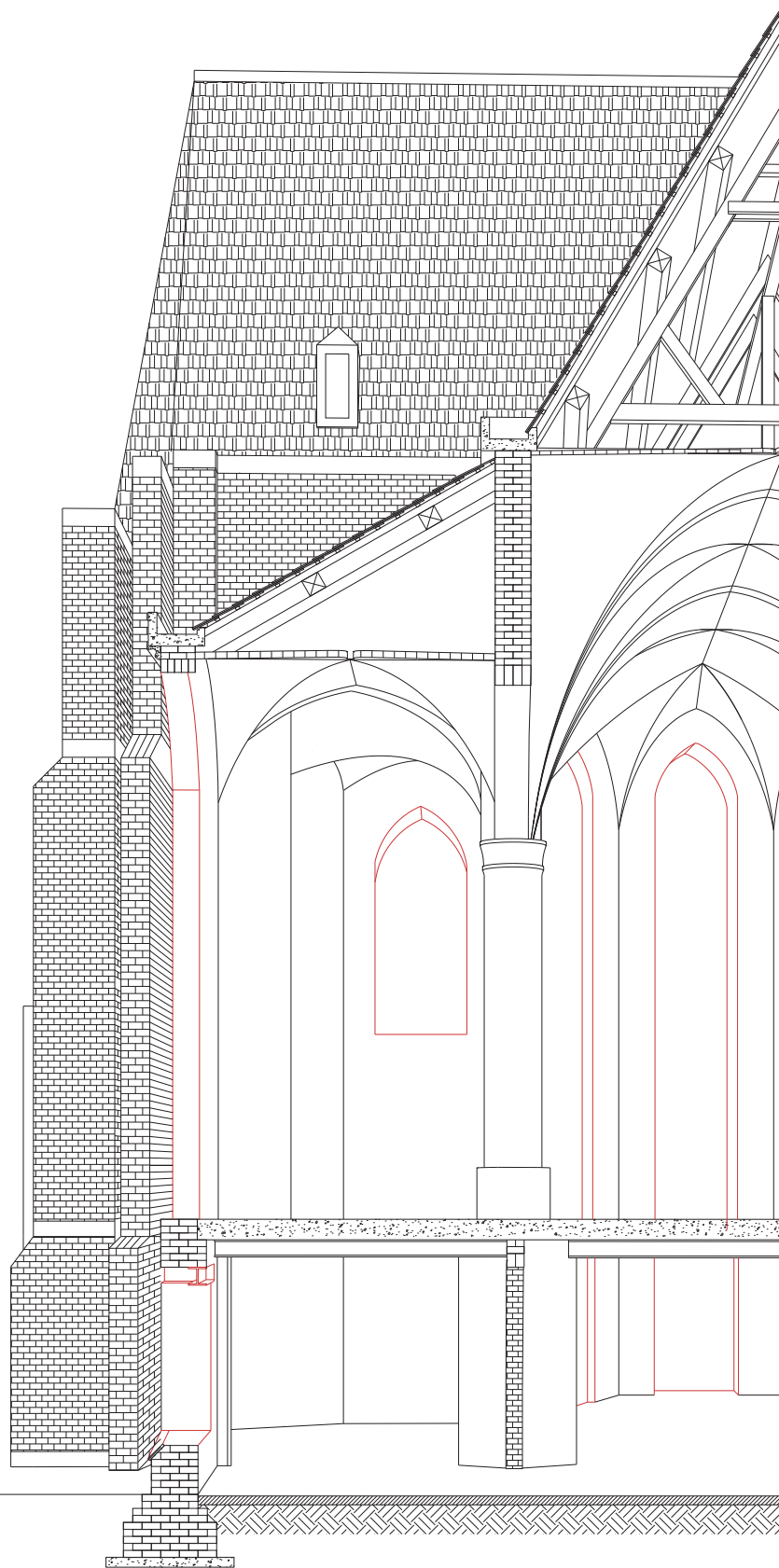

Demolition and Preparation

Stage 6:
Insulating the skin
Undertaken by:
The Construction Crew

1
Introducing bund walls as support for the windows

2
Windows are CnC routed from harvested Glulam and double planed windows are placed within these frames

3
Placing the new windows on the elevation

Insulating the facade with new windows

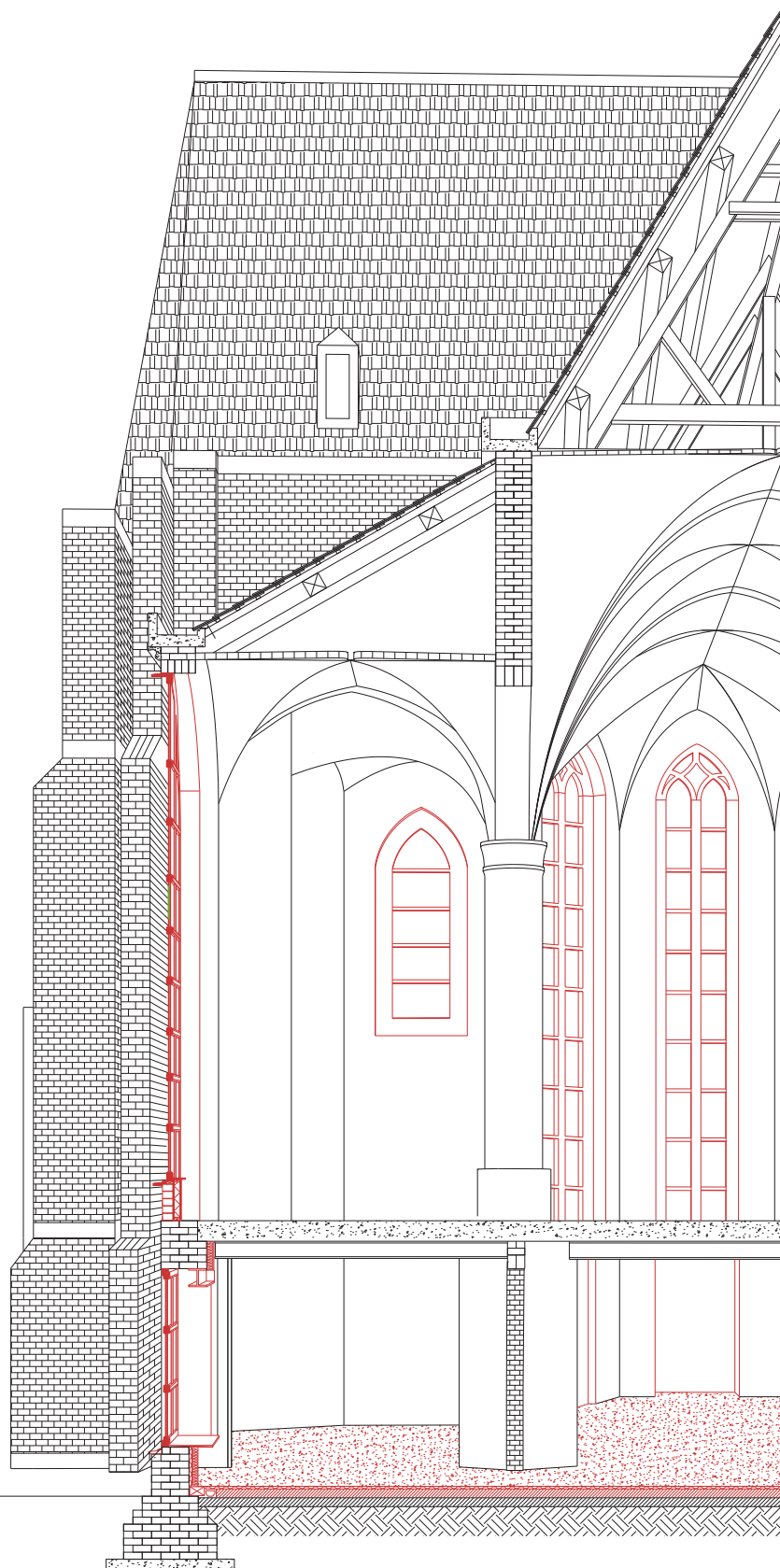

Altar

Insulated stained glass windows:
60 sq.m double glazed units

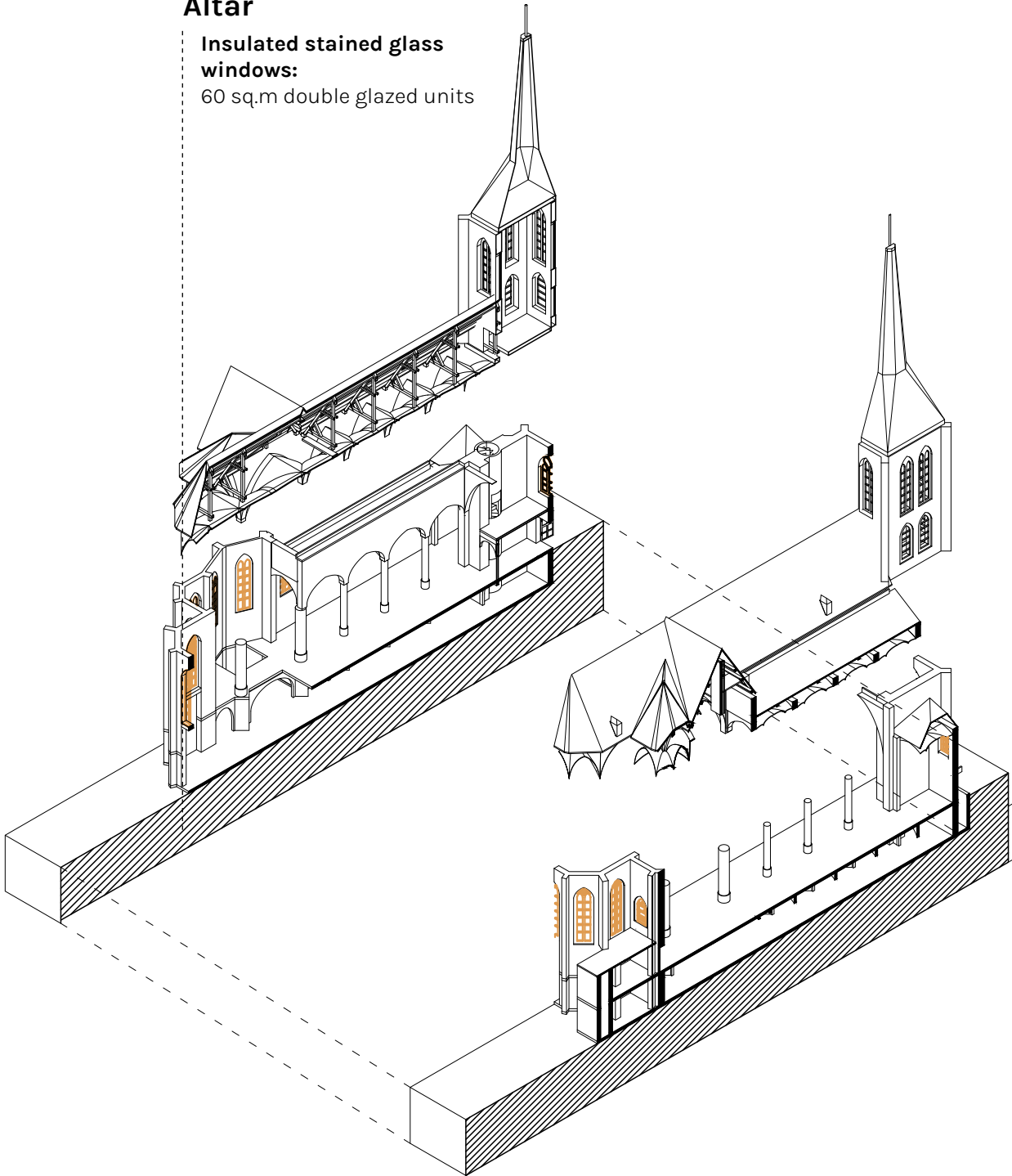

Aisles

**New double glazed units
added:**
128 sq.m double glazed
units

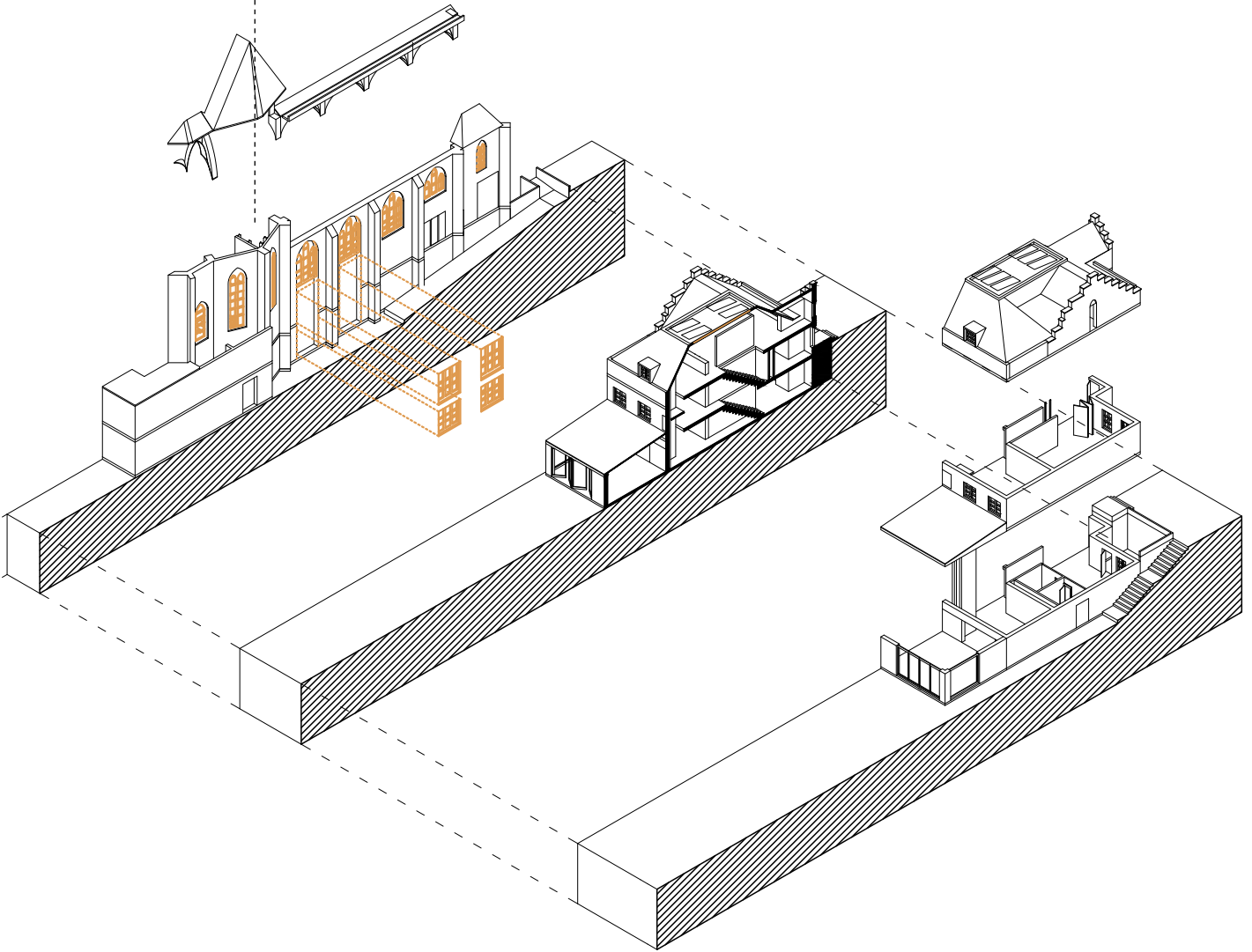

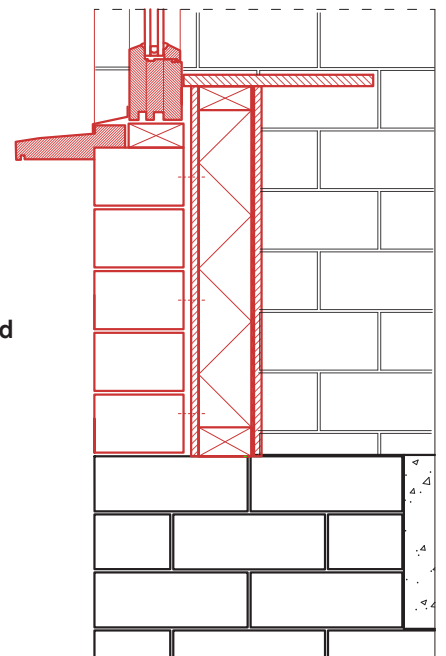
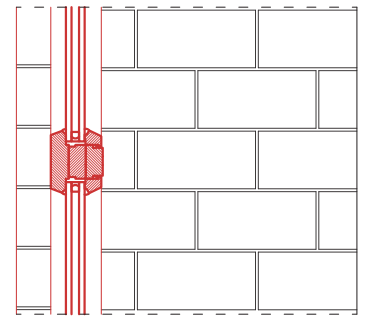
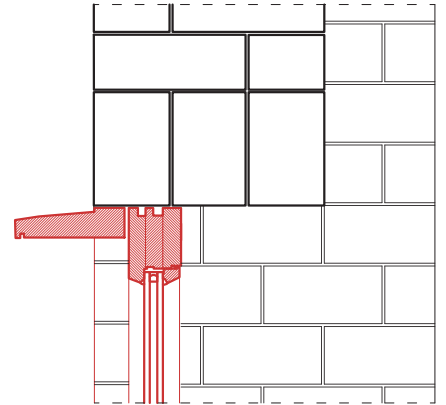
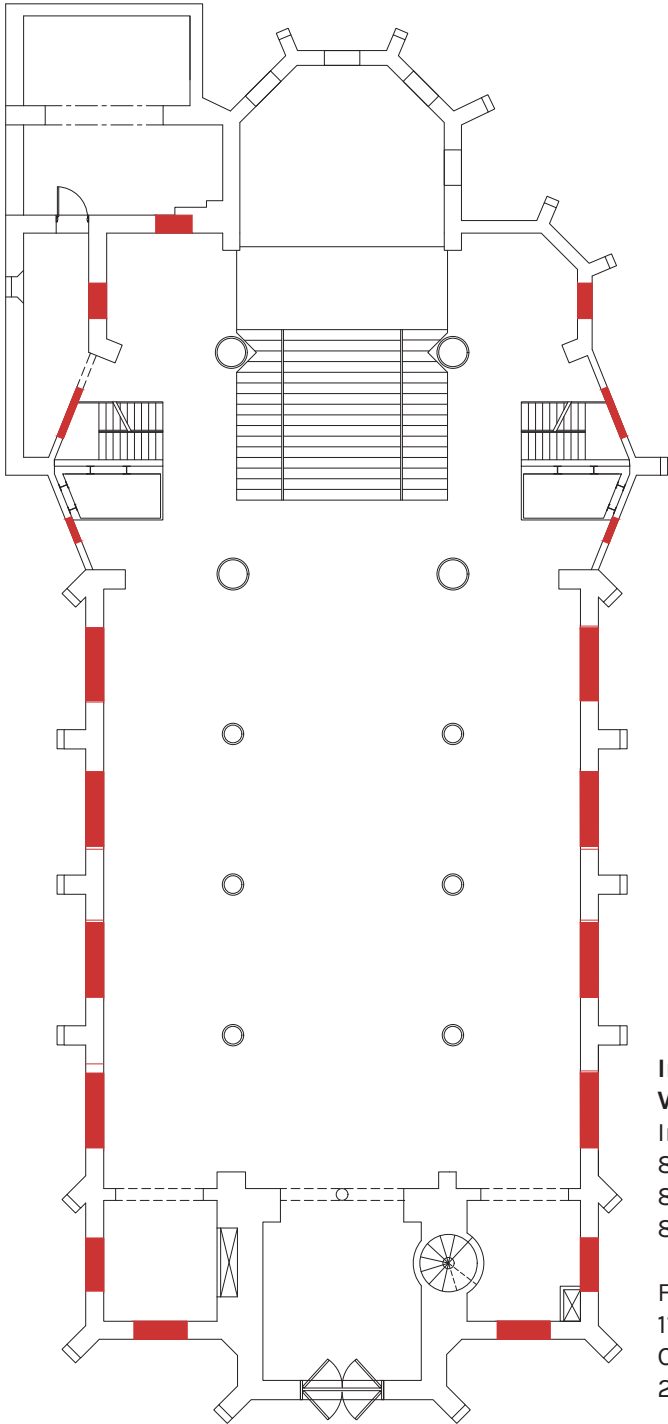

Insulated Double Glazed Window:

Inside to Outside
 8 Clear Glass Pane
 8 Sealant
 8 Clear Glass Pane

Frame Components:
 114x68 glulam wooden
 CnC routed Frame
 25x114 wooden sill

Stage 6:
 Insulating the skin
 Undertaken by:
 The Construction Crew

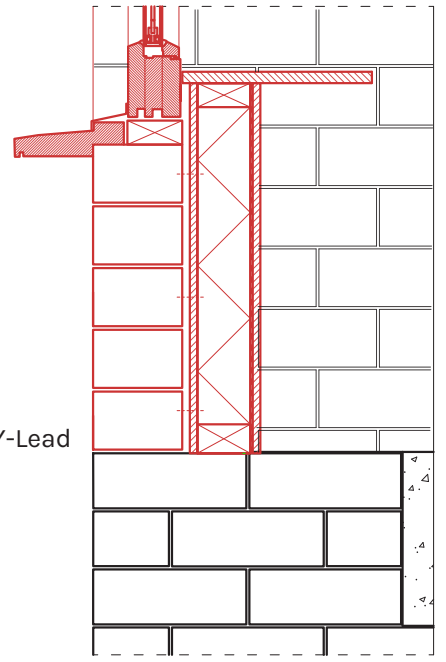
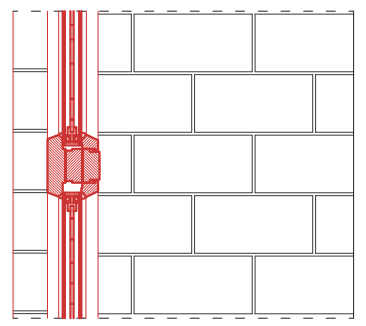
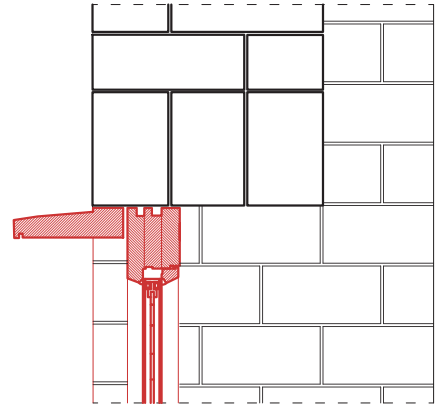
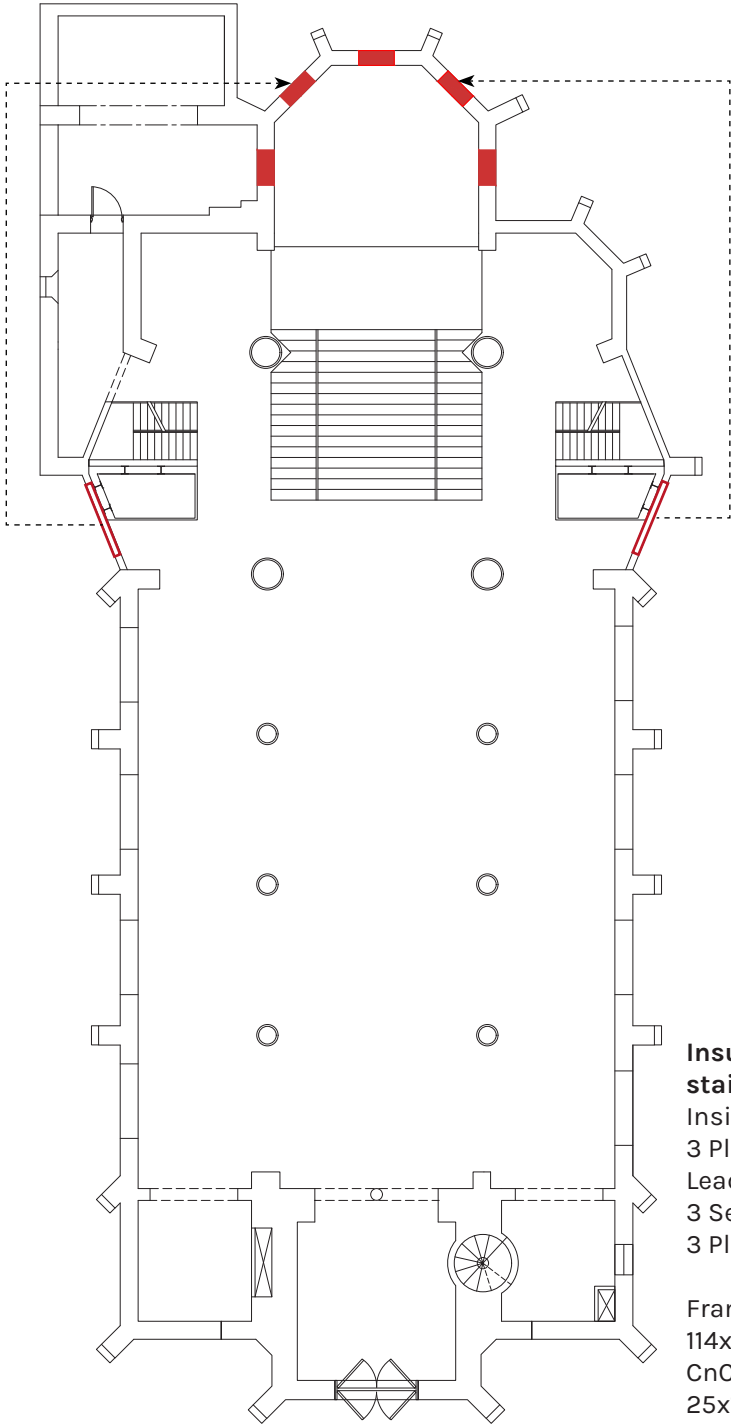

**Insulated Triple Glazed
stained Glass Window:**
 Inside to Outside
 3 Plane Glass panel
 Leaded glass pane with Y-Lead
 3 Sealant
 3 Plane Glass panel

Frame Components:
 114x68 glulam wooden
 CnC routed Frame
 25x114 wooden sill

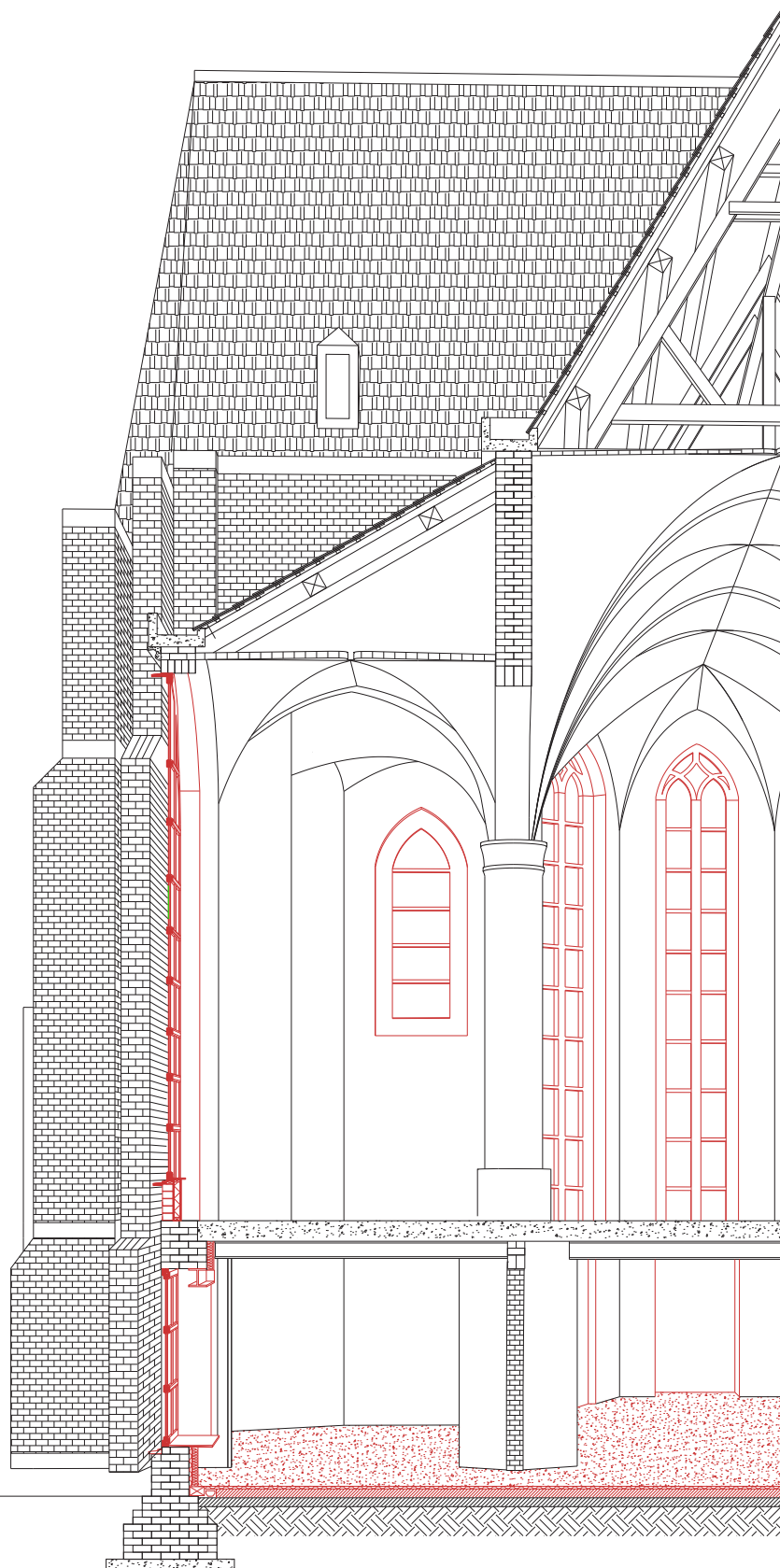

Insulating the facade with new windows

Stage 6:
Insulating the skin
Undertaken by:
The Construction Crew

1
The slate roof is repaired
and replaced with new
pieces wherever necessary

2
Wooden rafters are fit within
the existing rafters at
750mm c/c

3
Hemp Wool Insulation
panels are fit within the
rafter system

**Insulating the
roof**

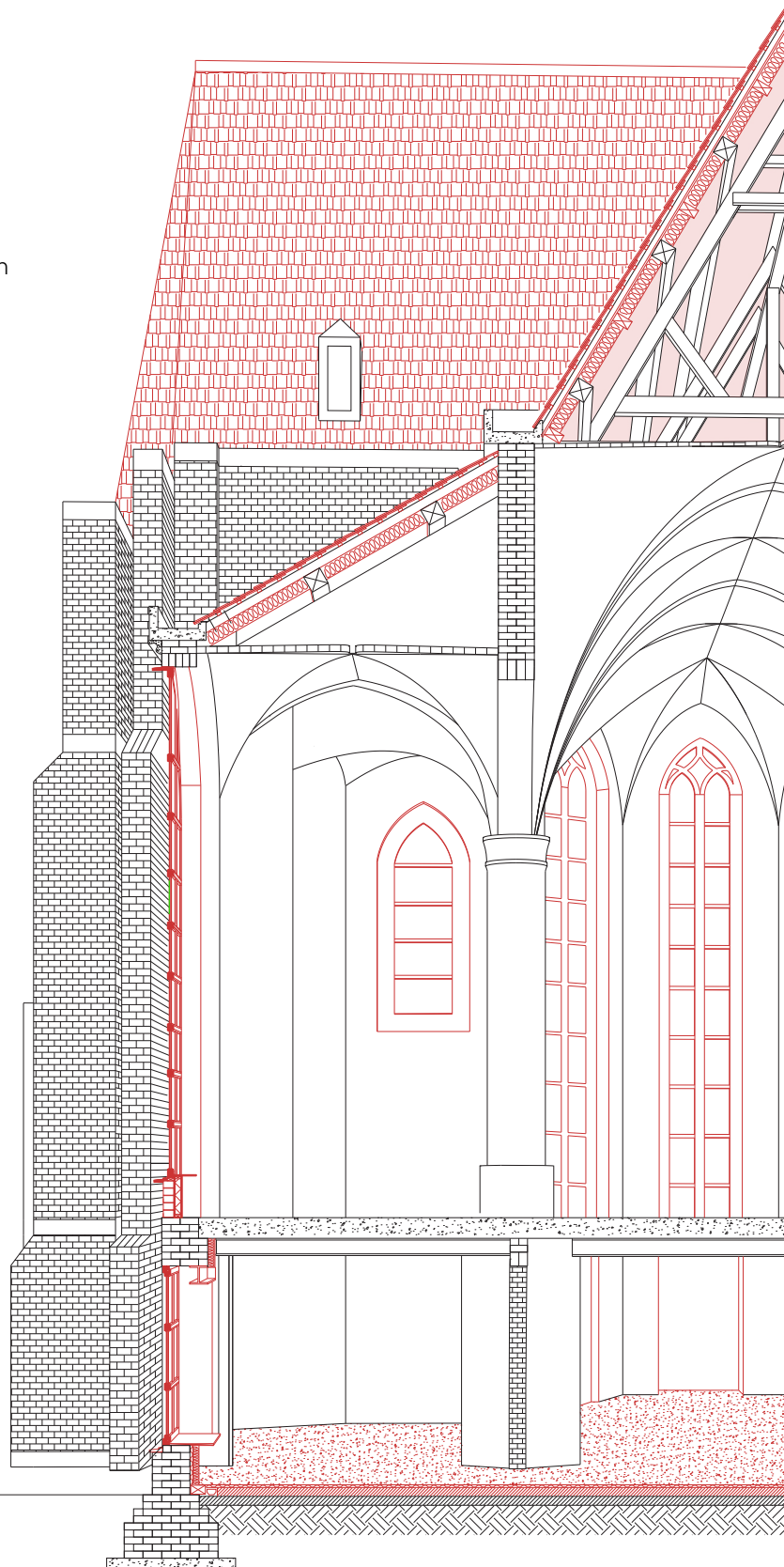

Fabrication of Components

Motive:

The design is a mix of assembled components placed together to create the interior spaces. This is carried out within the fabrication room and then assembled inside the church.

How-to:

The fabrication team is taught how to use the equipment and given a guide to the creation of each component. They will produce the individual units which will then be assembled by the assembly team inside the church. The components to be assembled include the collapsible walls in the basement, the timber structure, floors, walls and storage areas for the workshops and vertical circulation systems.

Undertaken by:

Fabrication Team

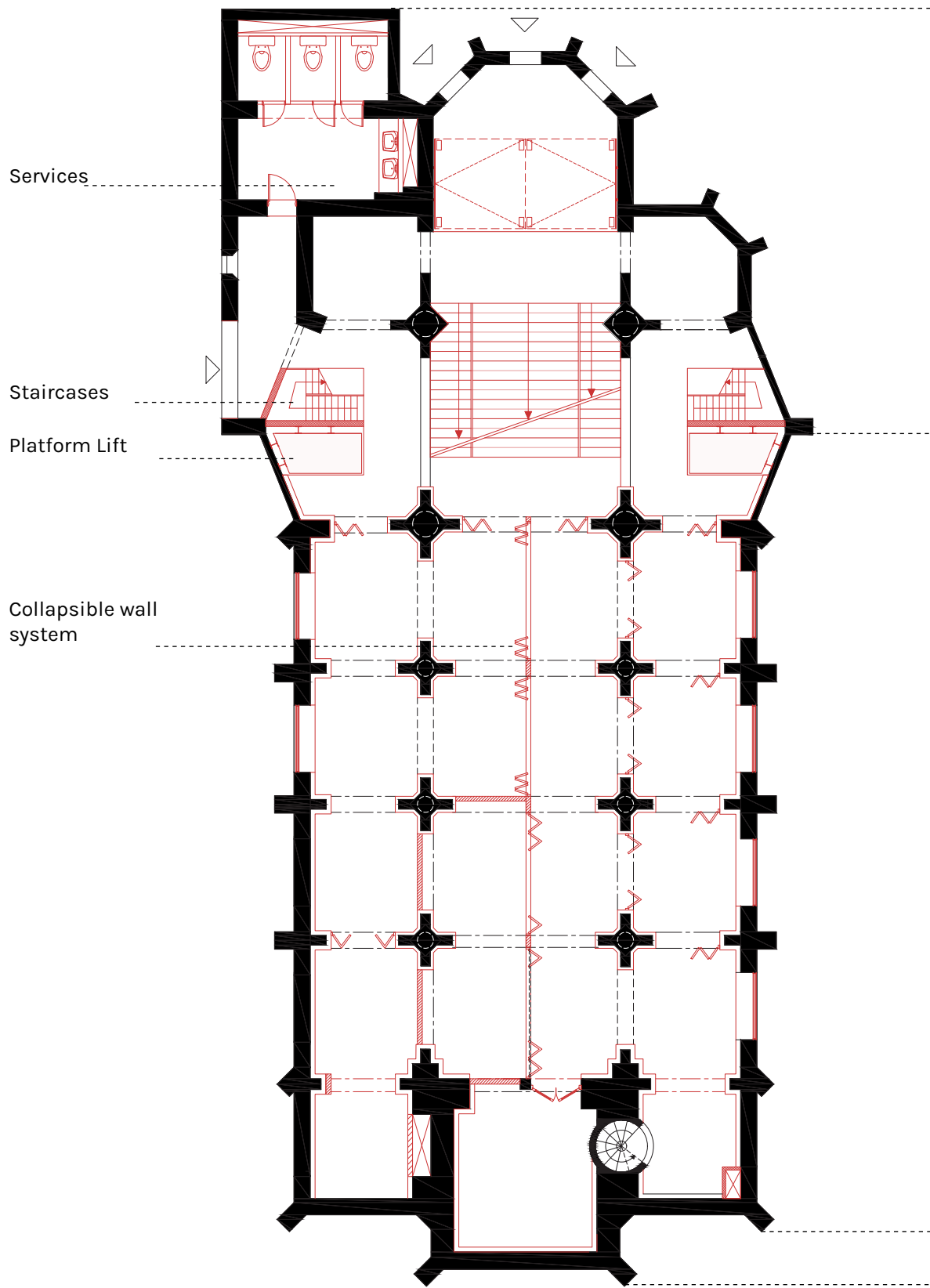

Lower Ground Floor

Stage 7:
Fabrication of the components
Undertaken by:
Fabrication Team

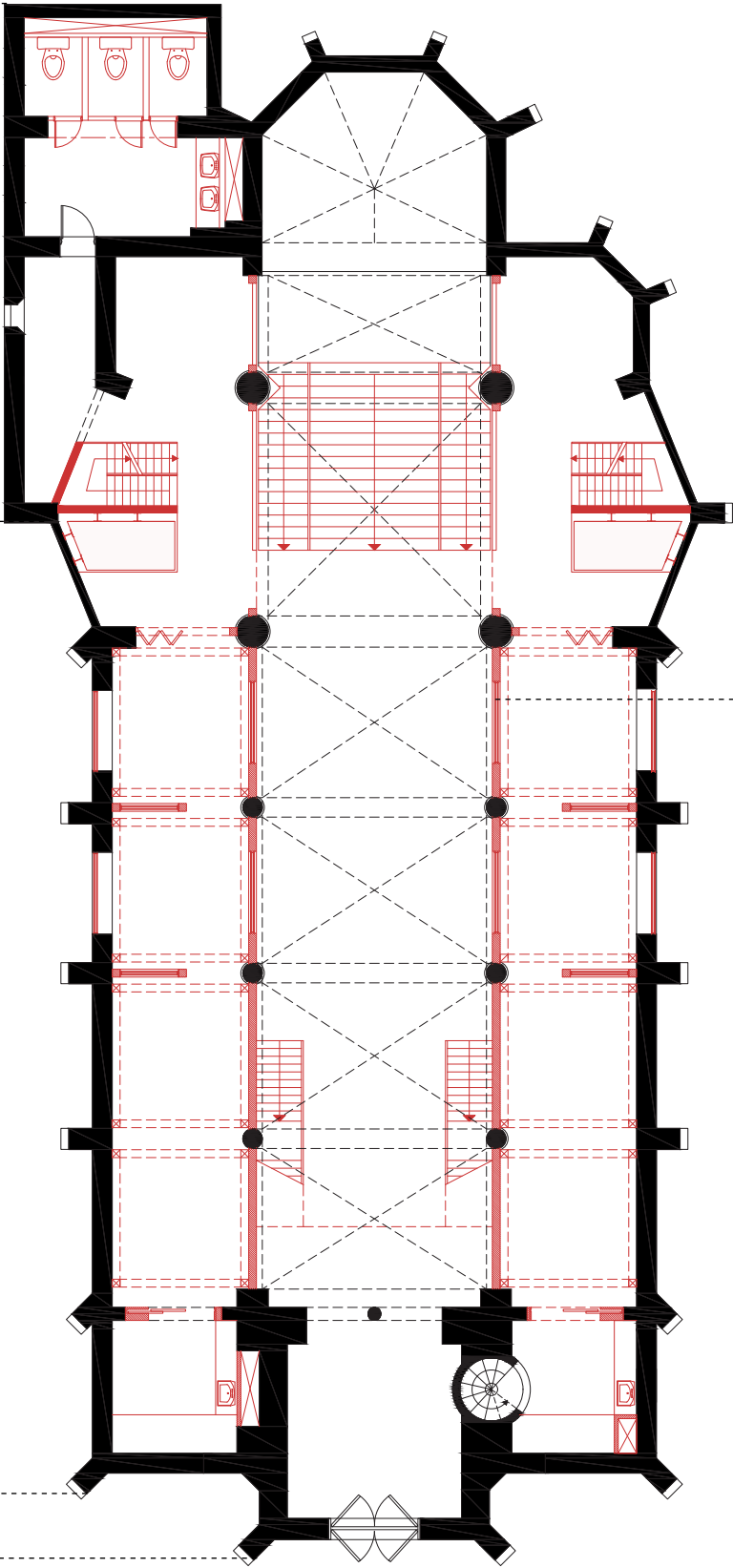

Workshop Areas:
Timber Frame
Plywood walls
Interior Walls

Upper Ground Floor

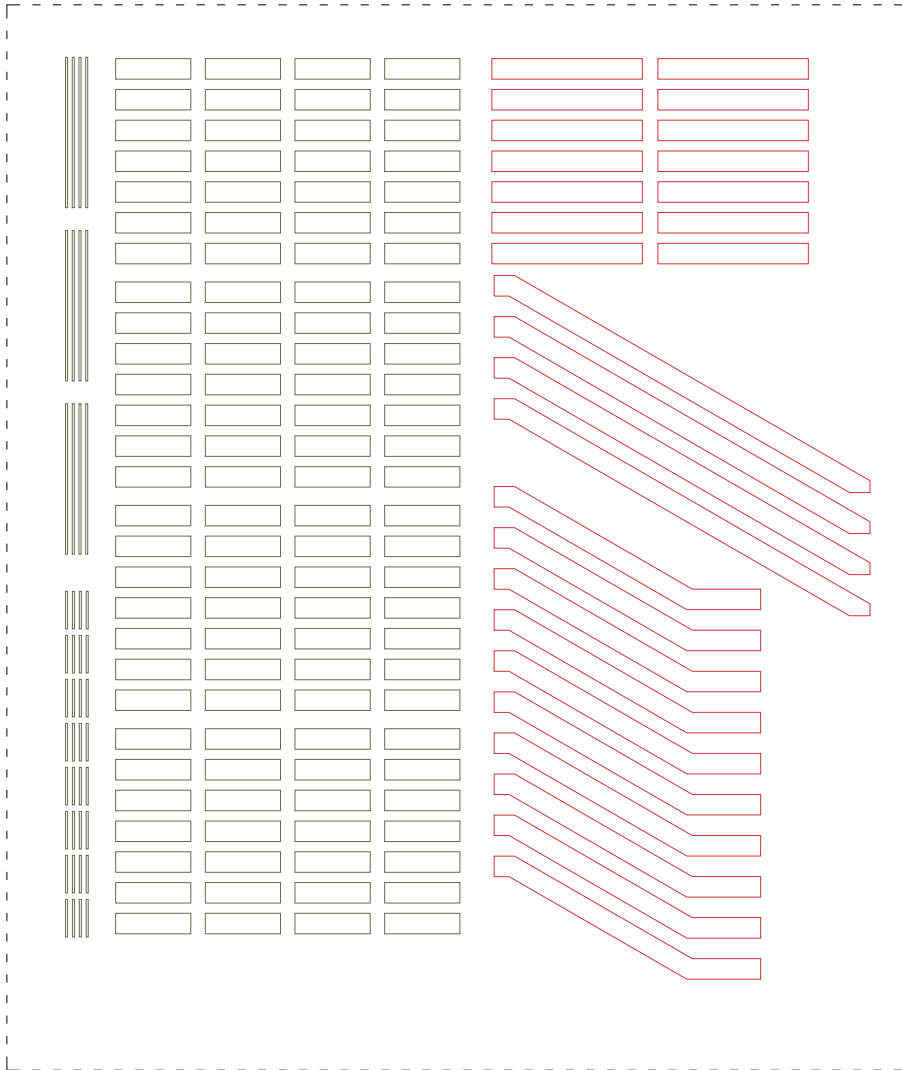

Vertical Circulation

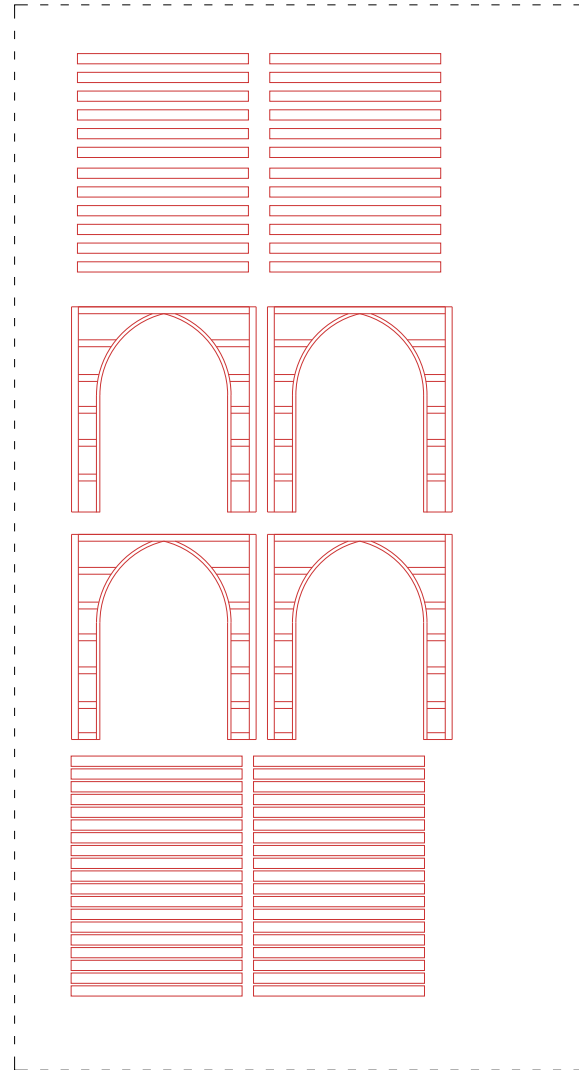

Workshops

Stage 7:
Fabrication of the components
Undertaken by:
Fabrication Team

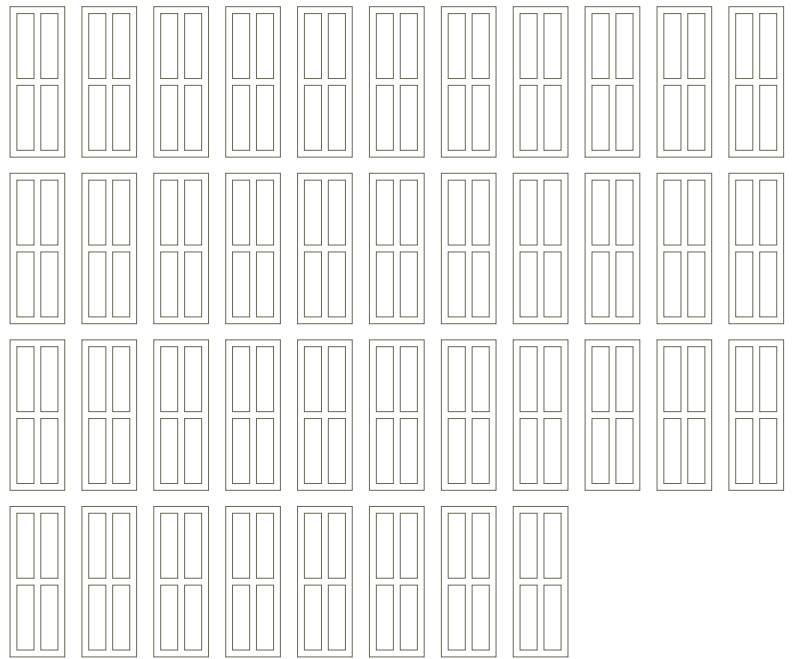
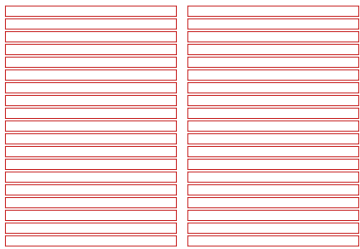
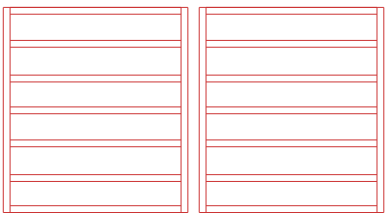
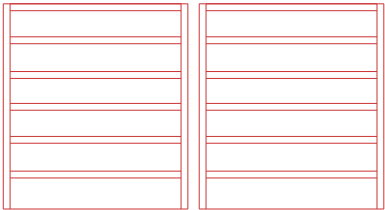
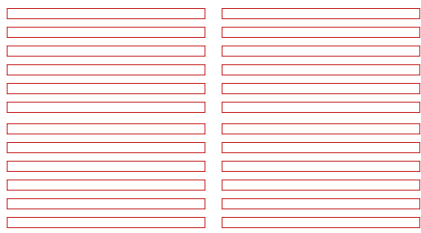

Basement Walls

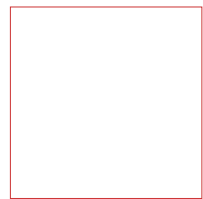
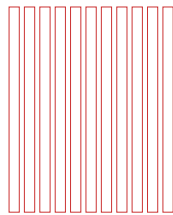

Stage

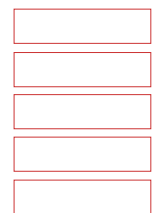
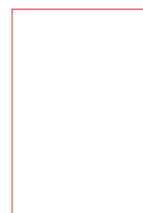
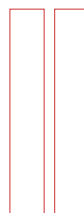
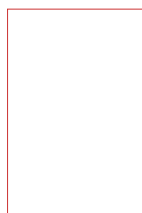

Storage

Assembling the workspaces

Motive:

The components created in the fabrication space are then assembled in the church. The first components to be assembled include the workshops and equipment storage spaces

How-to:

This process includes three steps, the laying of the floor heating system, joining the timber column and beam system and adding wall and floor infill components

Undertaken by:

Assembly team



1

Preparation of the Site:

The church is prepared for the introduction of new elements. Furniture is removed and wooden flooring is stripped.



2

Timber structure:

The timber structure made of reclaimed wood is built in such a way that it stands separate from the old structure



3

Infill Materials:

The skin is placed on the structure with flooring and heating connected to the heat pump.

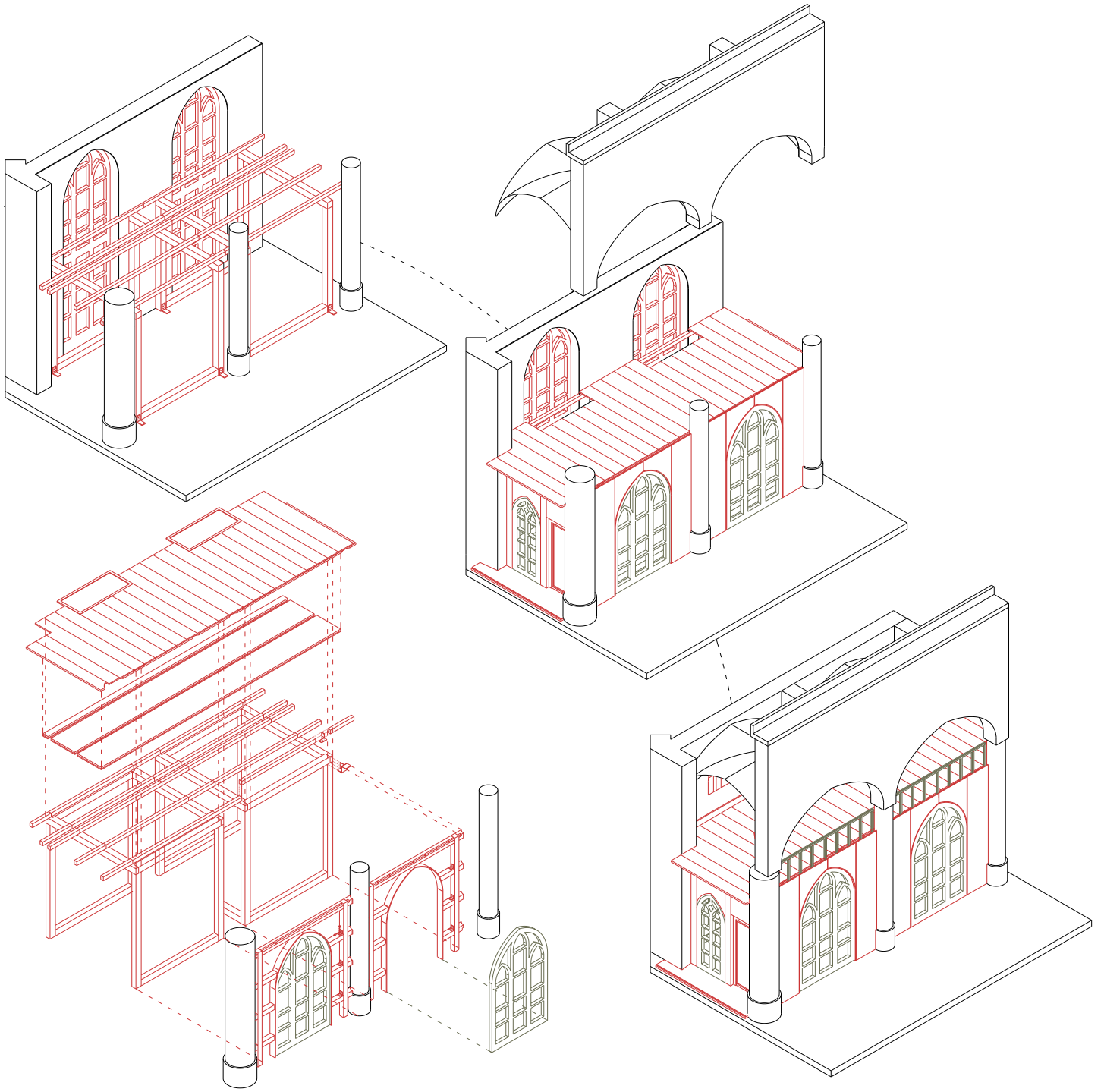

3

Timber structure to windows

The timber structure made of reclaimed wood is attached to the window system using a horizontal glass pane that allows light into the otherwise dim space

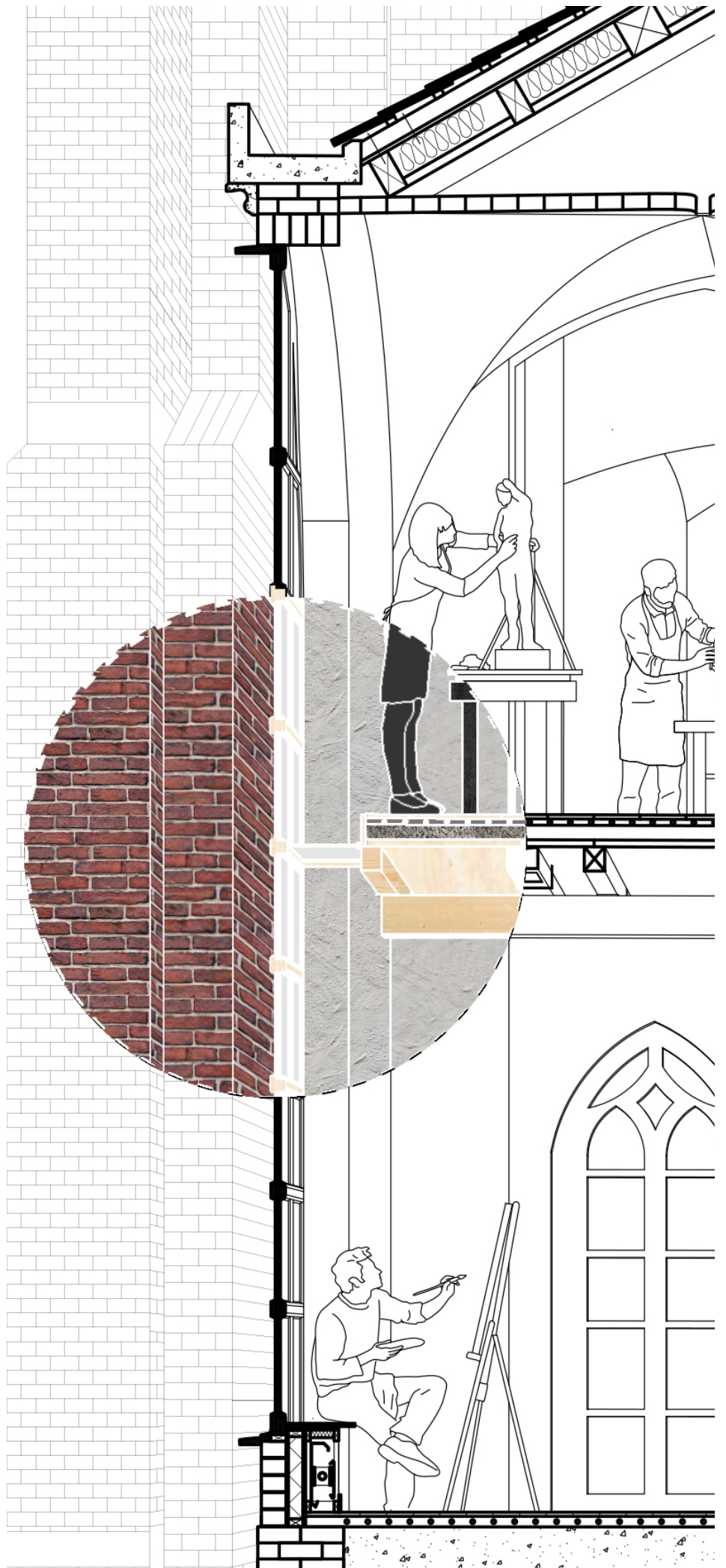

Stage 8:
Assembling the Workshop
Undertaken by:
Assembly Team

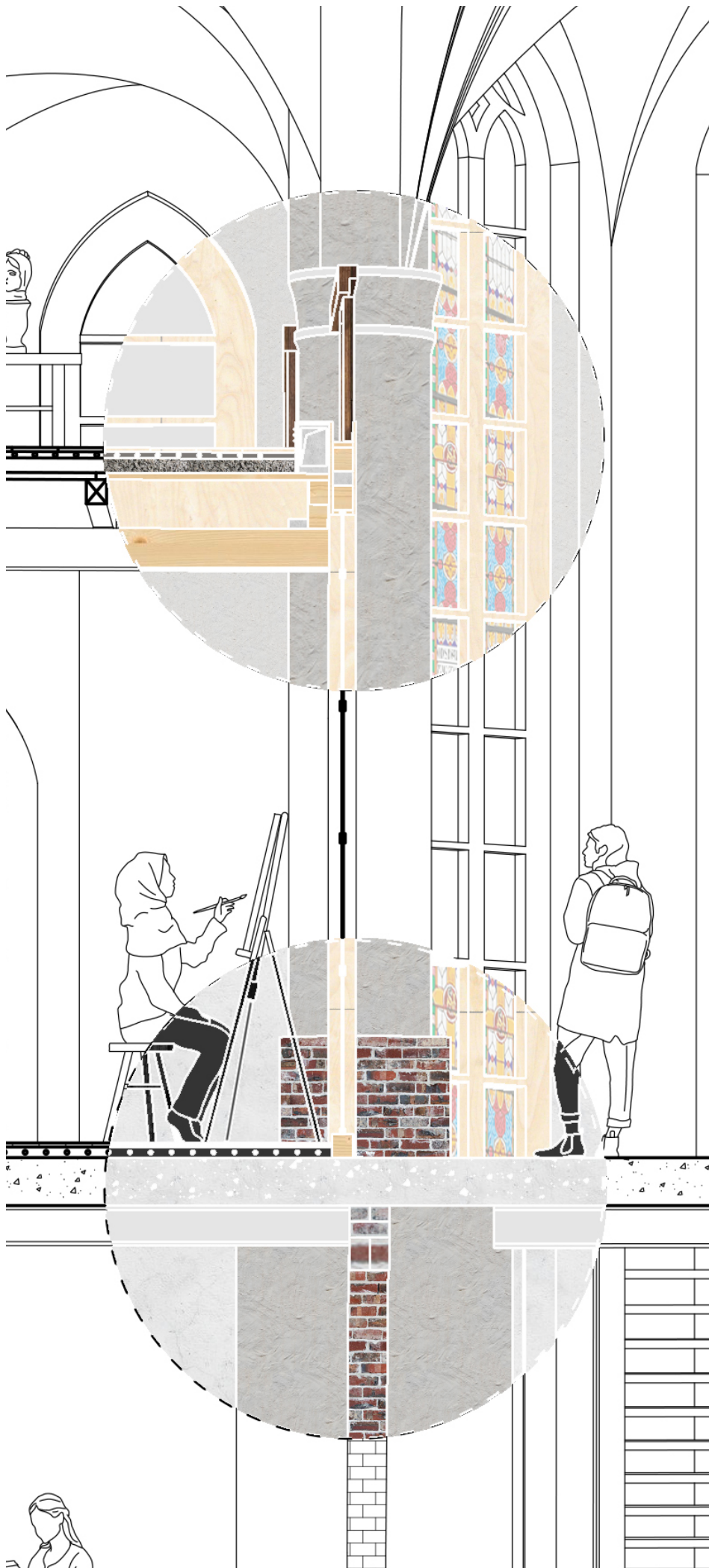

2

Timber structure:

The infill walls and the floor attach to the timber structure through a stacked joinery system (refer image 8.3)

1

Timber structure:

The timber reclaimed wood beam and column system is attached to the new floor with floor heating using angle cleats



Floor Configuration 1:

- 20 reclaimed timber plank flooring
- 75 Floor heating with pipe
- 100mm cc
- 150 Hempcrete insulation
- 20 Plywood
- 110x155 Rafter

750x2100 Tempered Horizontal Window

Insulated Double Glazed Window:

- Inside to Outside
- 8 Clear Glass Pane
- 8 Sealant
- 8 Clear Glass Pane

75x75 Angle Cleat

110x155 Harvested Spruce Beam

300x300 Steel Plate

110x155 Harvested Spruce Column

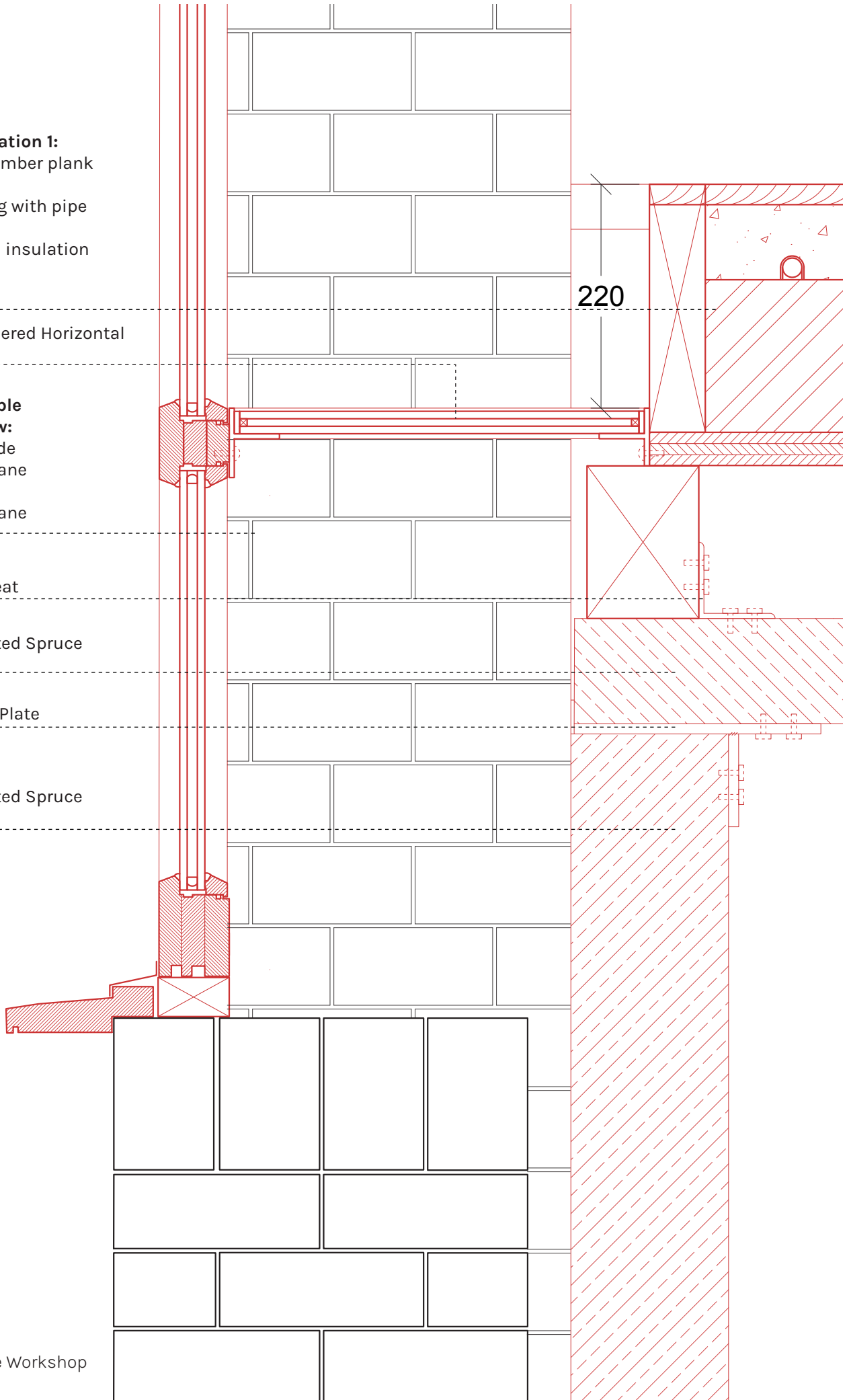

Stage 8:
Assembling the Workshop
Undertaken by:
Assembly Team

Floor Configuration 1:

- 20 reclaimed timber plank flooring
- 75 Floor heating with pipe
- 100mm cc
- 150 Hempcrete insulation
- 20 Plywood
- 110x155 Rafter

750x2100 Tempered Horizontal Window

Exterior Window:

- Inside to Outside
- 24mm double glazing
- 68x68 wooden sash
- 68x114 wooden frame
- 114x38 wooden frame
- 68x68 wooden apron

75x75 Angle Cleat

110x155 Harvested Spruce Beam

300x300 Steel Plate

110x155 Harvested Spruce Column

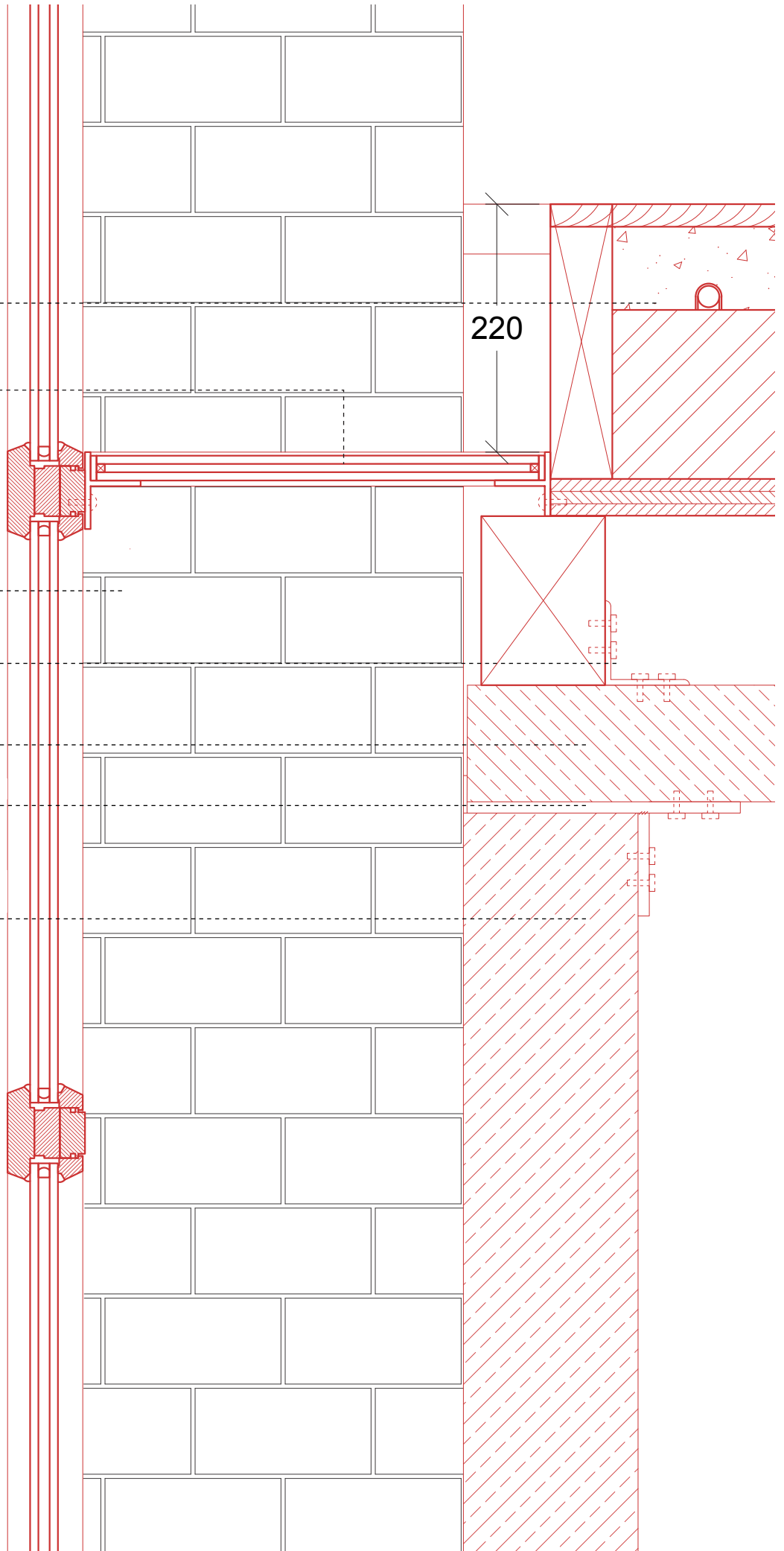

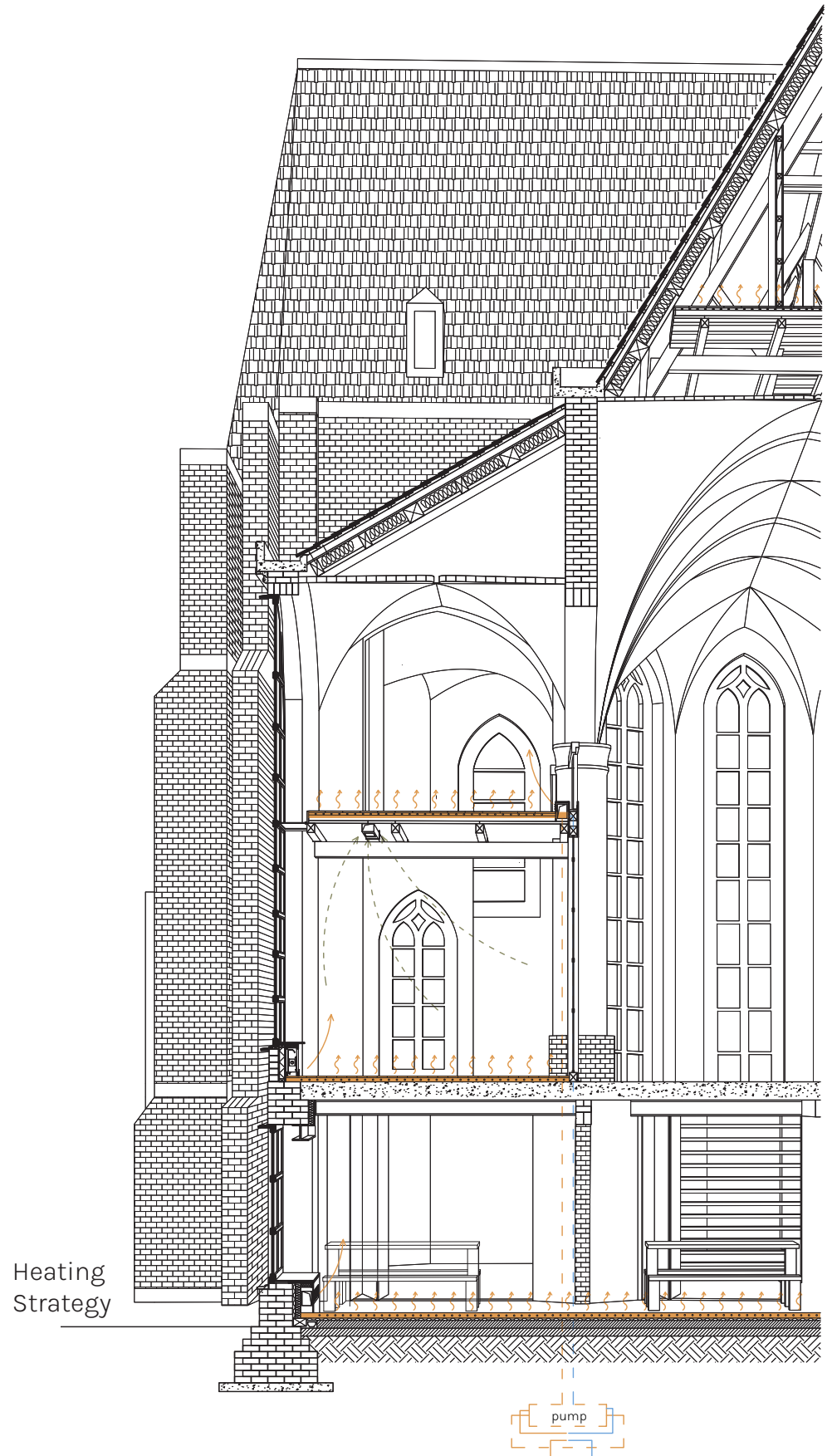

Heating Strategy

Stage 8:
Assembling the Workshop
Undertaken by:
Assembly Team

Rain water
harvesting
Strategy

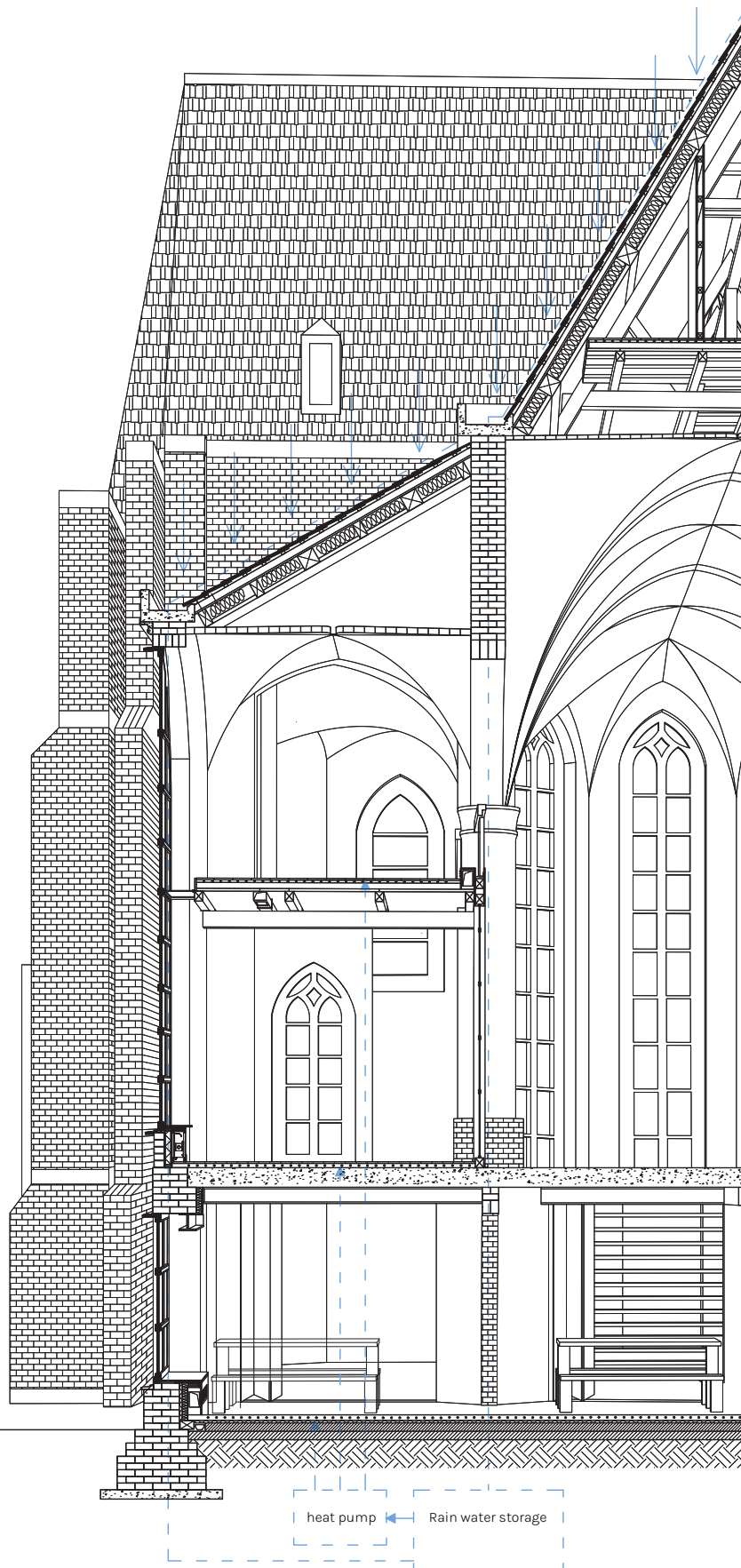

Insulated Double Glazed Window:

Inside to Outside Frame Components:
8 Clear Glass Pane 114x68 glulam wooden
8 Sealant CnC routed Frame
8 Clear Glass Pane 25x114 wooden sill

Exterior Bund Wall Configuration 1:

Inside to Outside
120x150 baseboard heating unit
20 plywood
vapour protection
75 Hempcrete Insulation
waterproofing
20 plywood
75 reused brick

Floor Configuration 1:

20 timber plank flooring
75 Floor heating with pipe 100mm cc

Existing Floor

Existing brick vault

Harvested 200x200
H-Beam

Stage 8:
Assembling the Workshop
Undertaken by:
Assembly Team

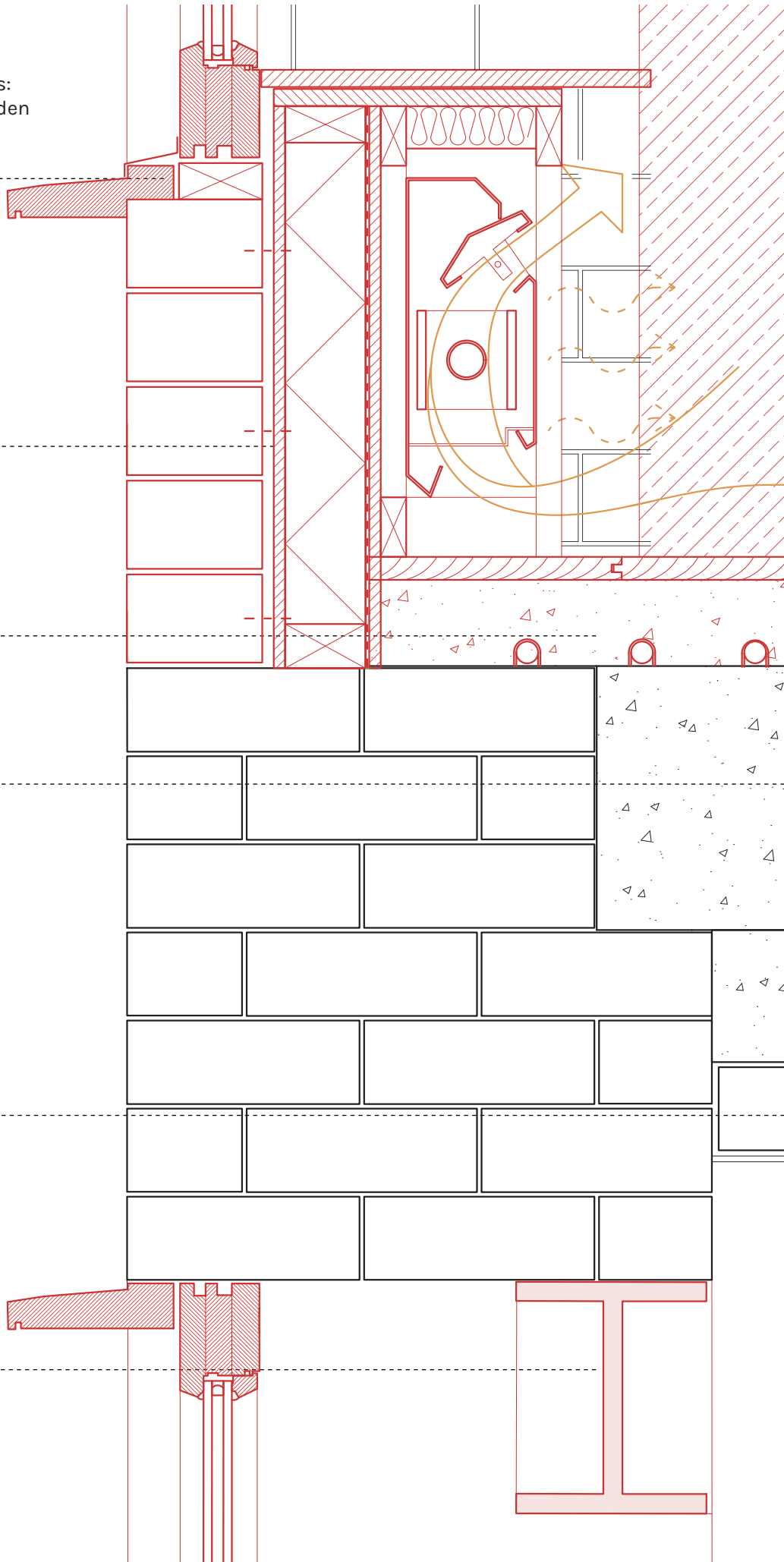

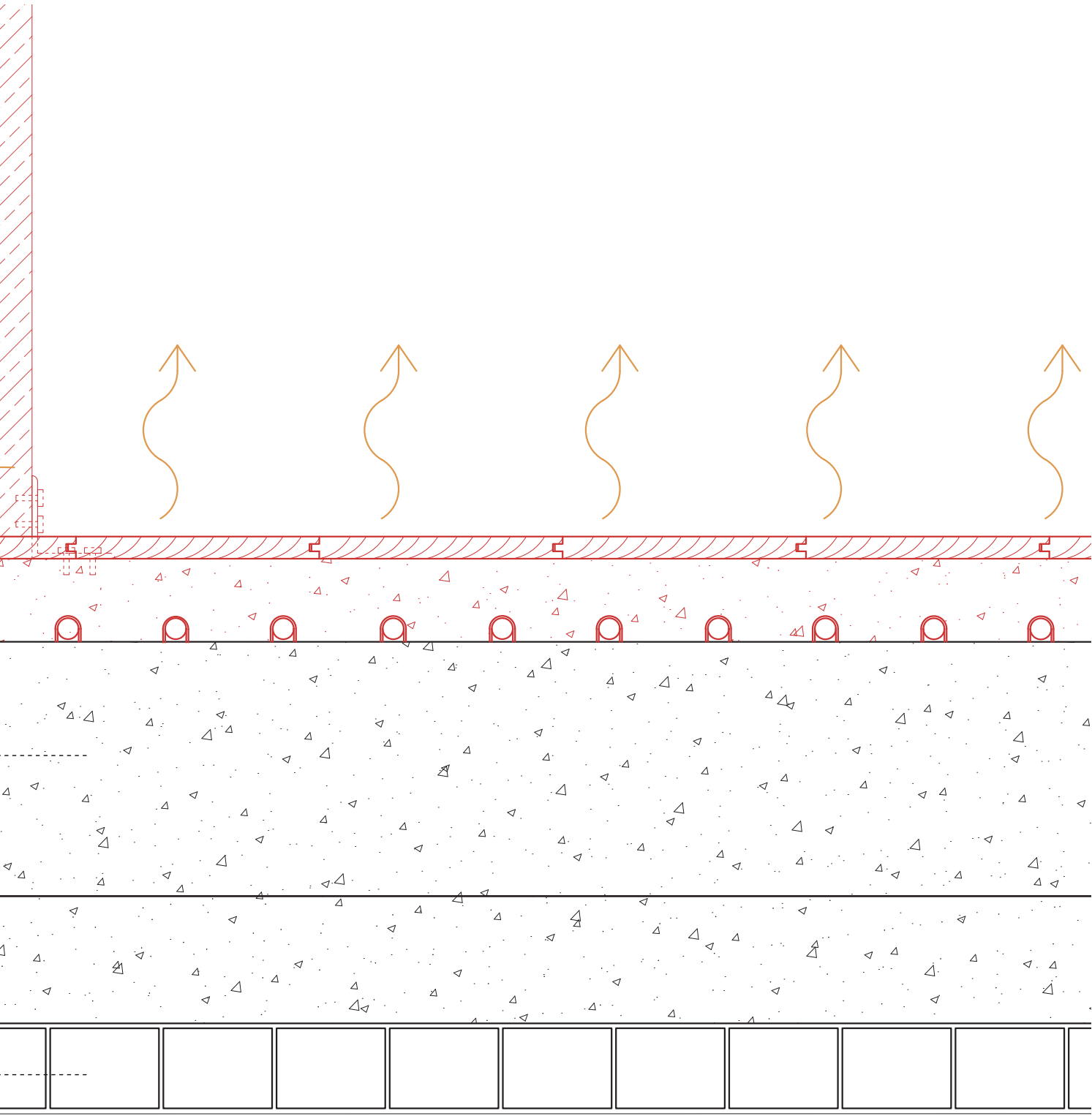

Adding circulation

Motive:

For vertical movement through the floor of the church, staircases and platform lifts are added. The platform lift also allow for arts and crafts pieces form the lower floor to go to the exhibition areas and makes the floor easily accessible for everyone

How-to:

A new platform lift is introduced with the use of H-beam from storage (originally harvested from the floor). A series of staircases for fire safety and accessibility are introduced which use sandwiched harvested door panels for treads and door frames for railings and balusters.

Undertaken by:

Assembly Team



Extension and vertical circulation:

The workshop spaces are extended and vertical circulation spaces are created.

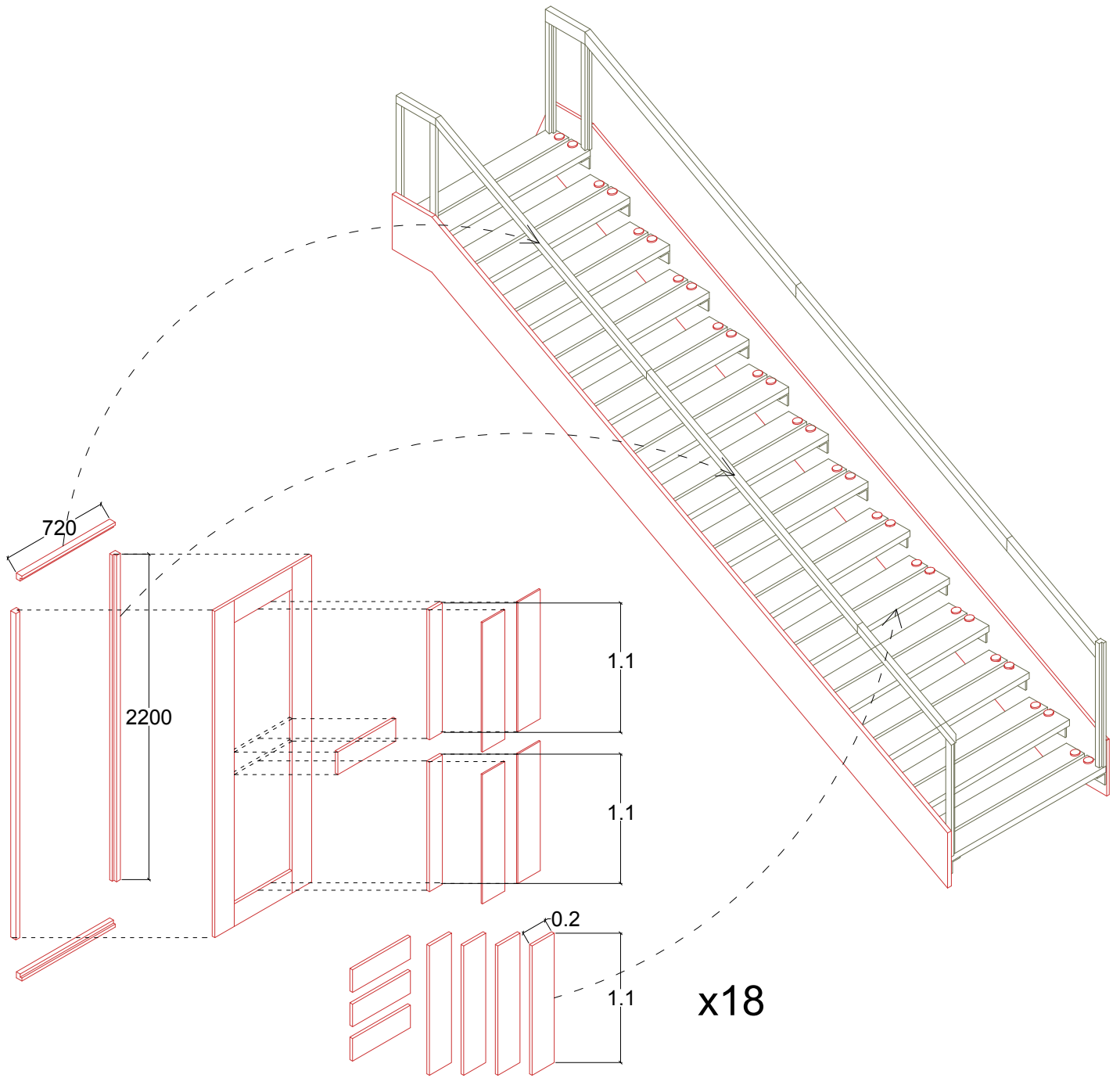



As vertical Circulation

The stair can act as a space for circulation with a riser of 150mm when performances are not in session



As a form of seating

When a performance is to take place, the treads can be manipulated to create seating for the audience

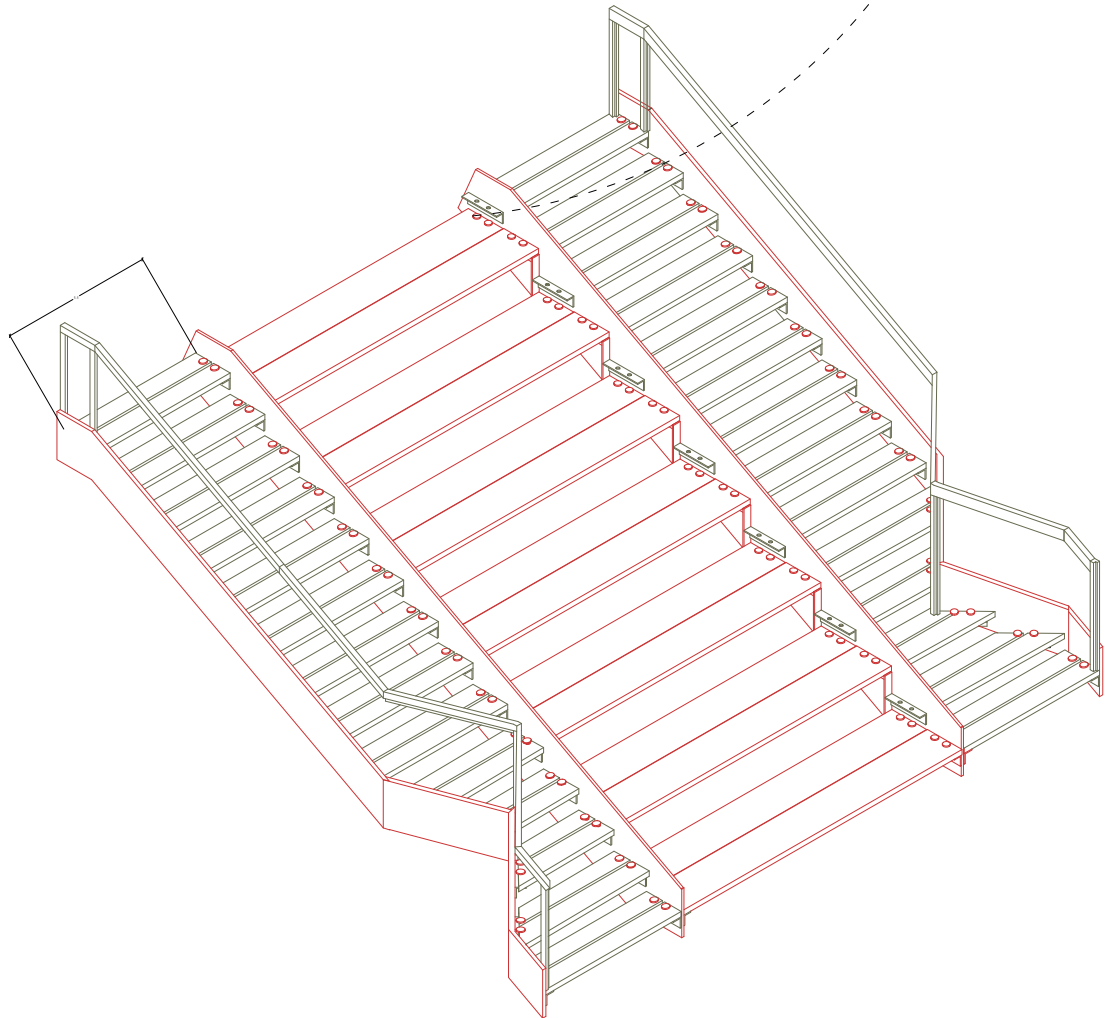
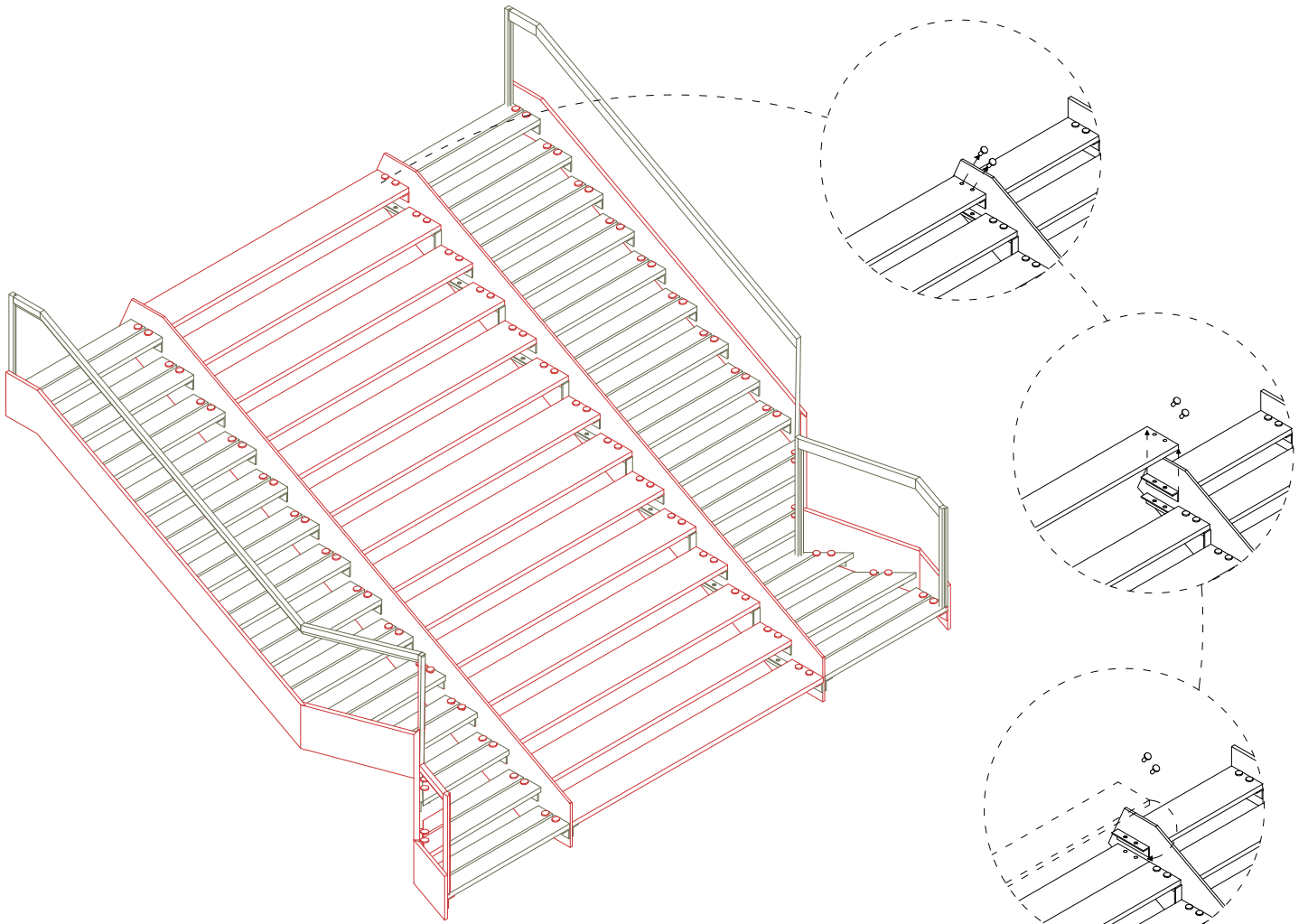

Adding Storage

Motive:

The arts and crafts spaces within the church are kept relatively flexible in terms of programme so that more forms of art can be encompassed within it. This requires an area where all the equipment for the various art forms can be stored.

How-to:

This is achieved by creating a fixed zone where storage of equipment is the only programmatic definition provided using shelves made of harvested plywood.

Undertaken by:

Assembly Team

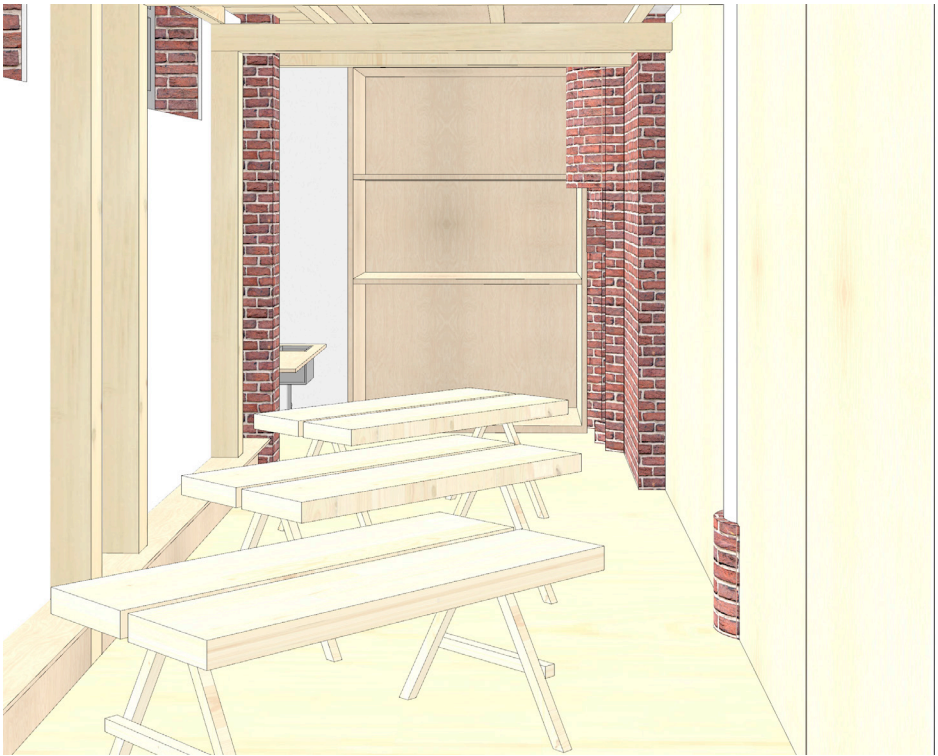

As vertical Circulation

Storage spaces are created with harvested plywood and joined in the original side altar. This forms a fixed area where equipment, furniture and art paraphernalia can be stored and then taken out whenever necessary

Collaboration
Zone

Vertical
Circulation
Zone

Flexible Art
Spaces

Fixed Storage
Area

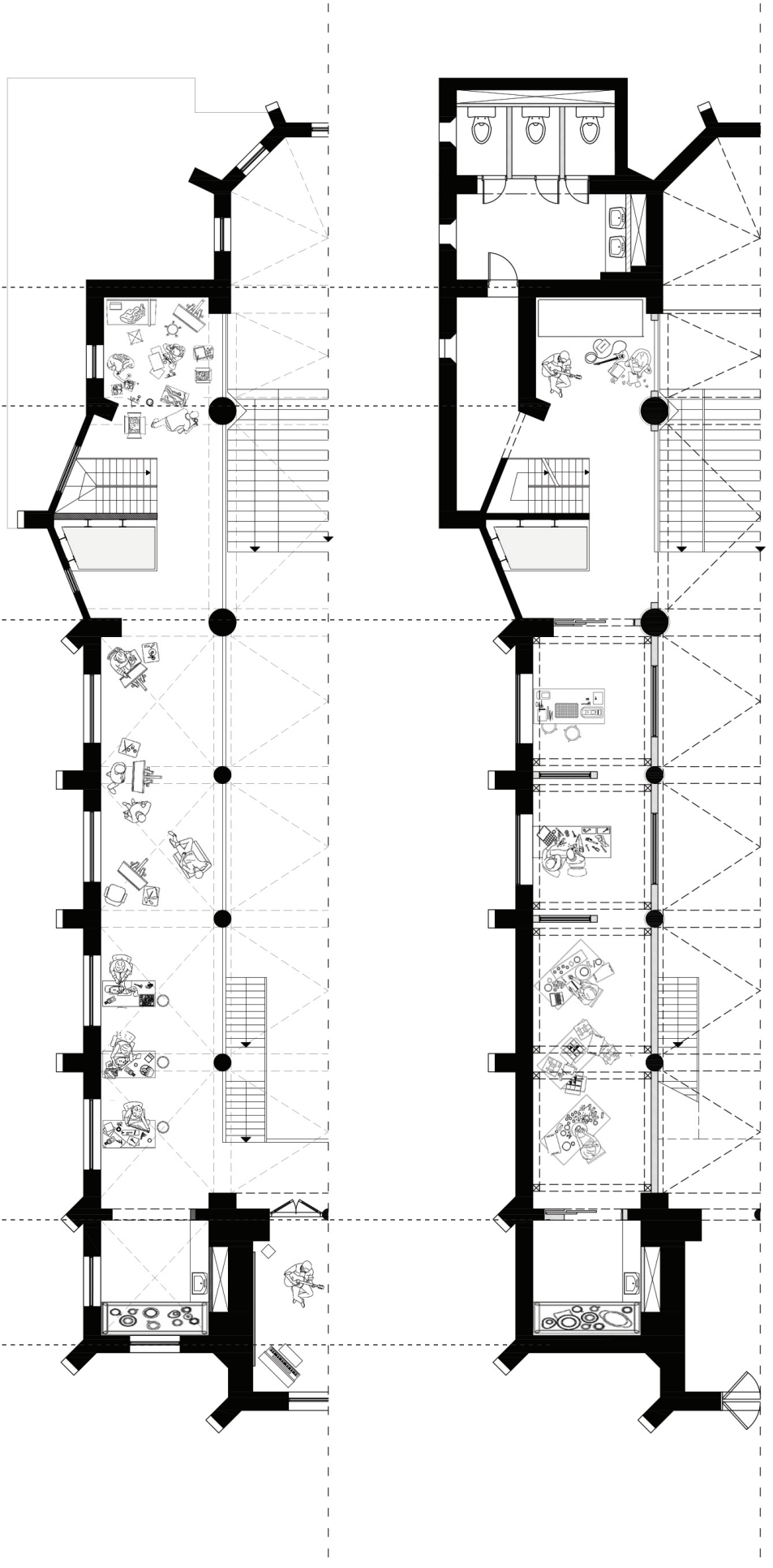

Creating the Stage

Motive:

A small performance space is created using components to create a stage and seating for the audience. The stage becomes a gathering space when it is in a closed position. It becomes a connector between the outside and inside and a space for movement. When open, the stage is a flexible space that accommodates theatrical expression when it is in the open position with anchors, platforms and steps.

How-to:

Harvested spruce beams and plywood create a stage that can be placed on hinges and opened whenever necessary. Below the stage, the earth is excavated and filled with cobblestones as a soft edge between the outside and the inside.

Undertaken by:

Assembly Team

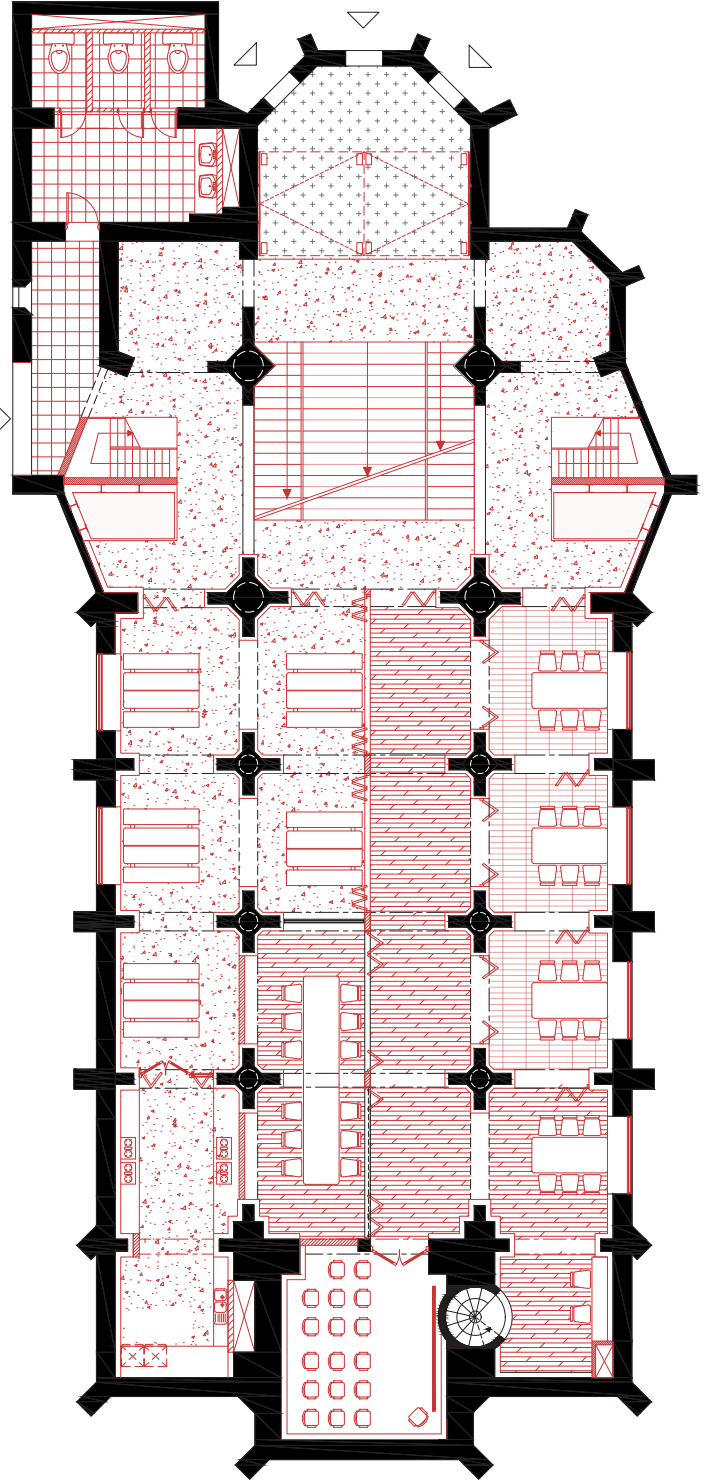
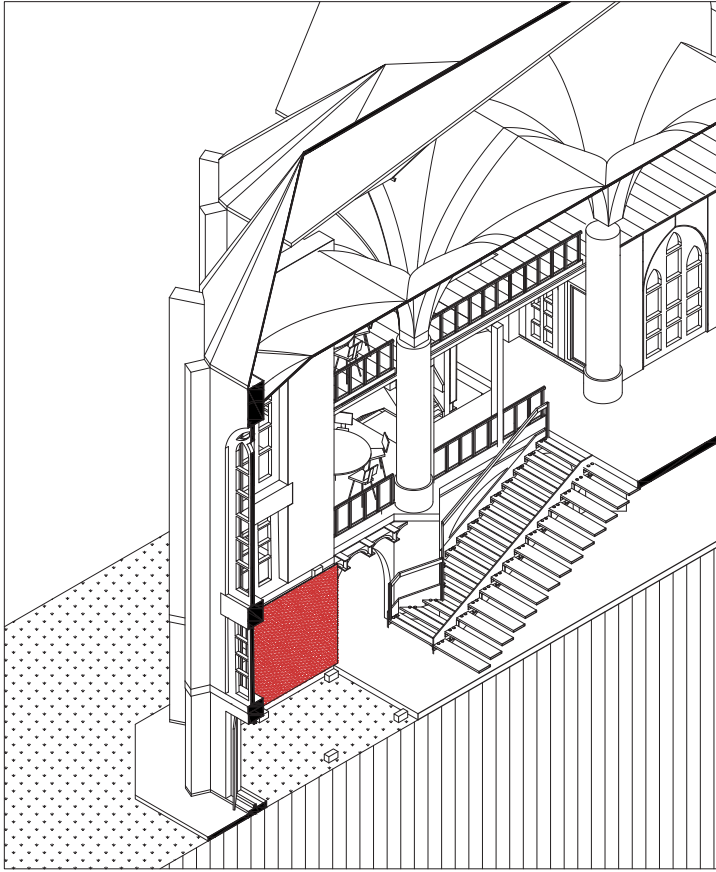

Stage 11:
Creating a Stage
Undertaken by:
Assembly Team

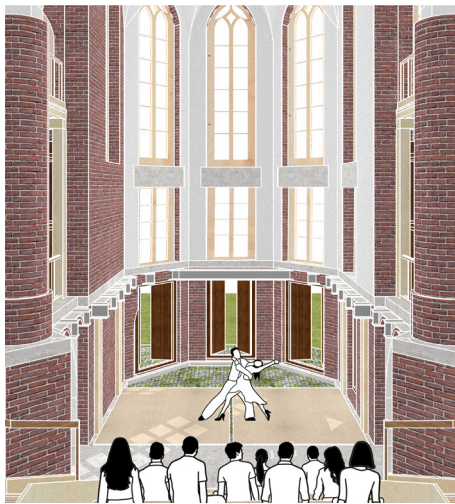
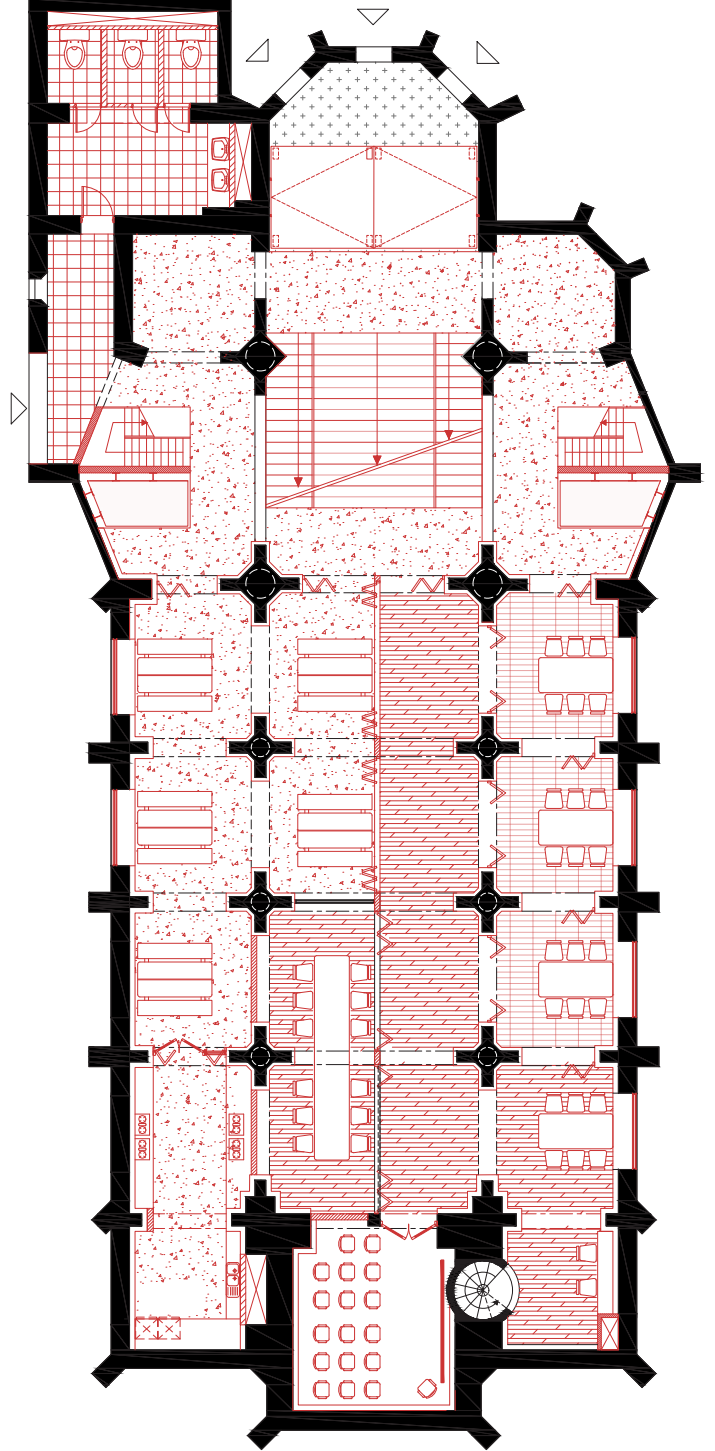
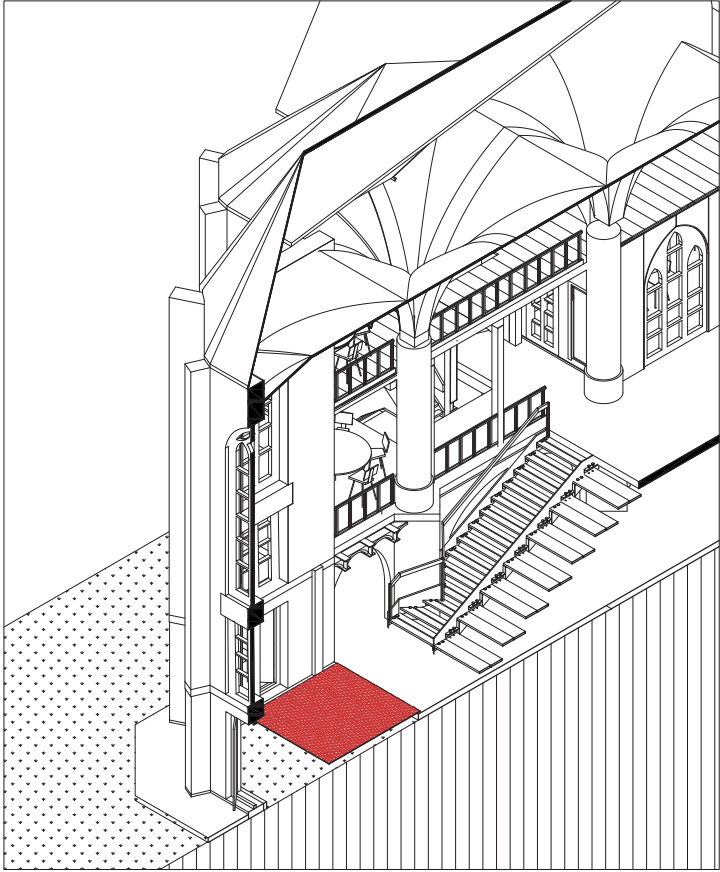

Creating the Communal Zones

Motive:

A community kitchen, an eating area and communal workspaces are created on the lower ground floor. These areas have the ability to be visually and physically accessible to one another to create a sense of camaraderie. Here, collapsible walls provide the opportunity for the areas to bleed into one another and whenever necessary, one programme can be extended into the other.

How-to:

Harvested doors, joined with hinges and placed on steel tracks are placed along the junction of every room.

Undertaken by:

Assembly Team

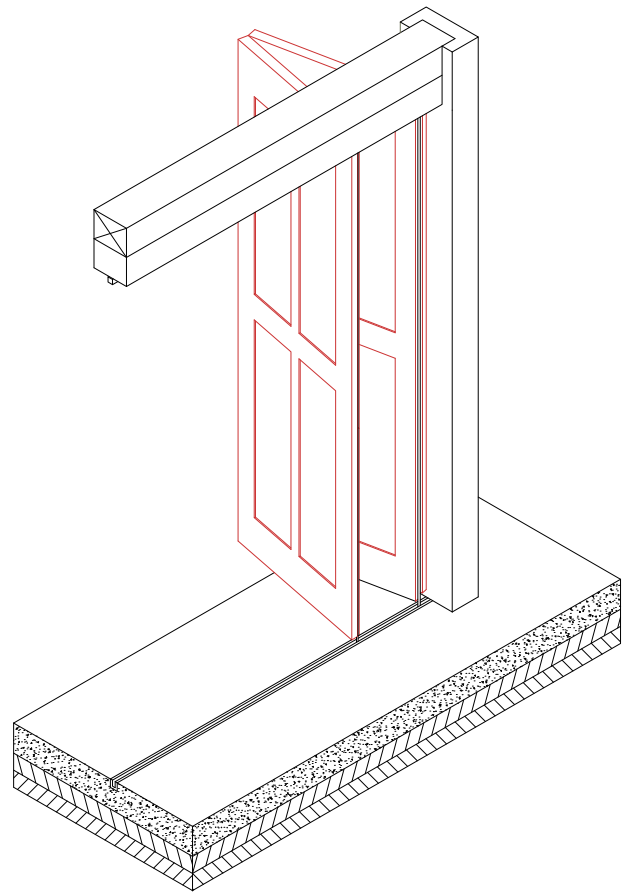
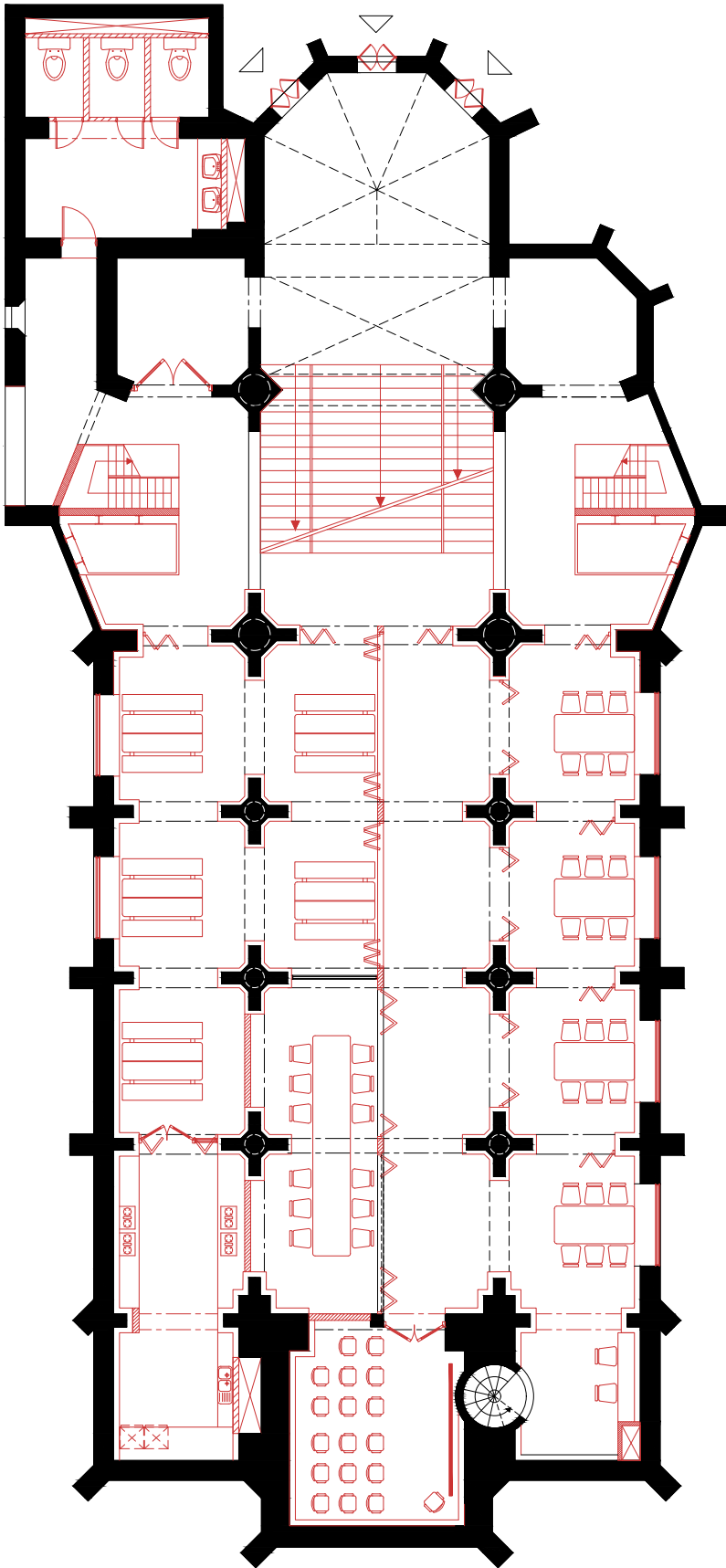

Stage 12:
Creating the Communal Zone
Undertaken by:
Assembly Team

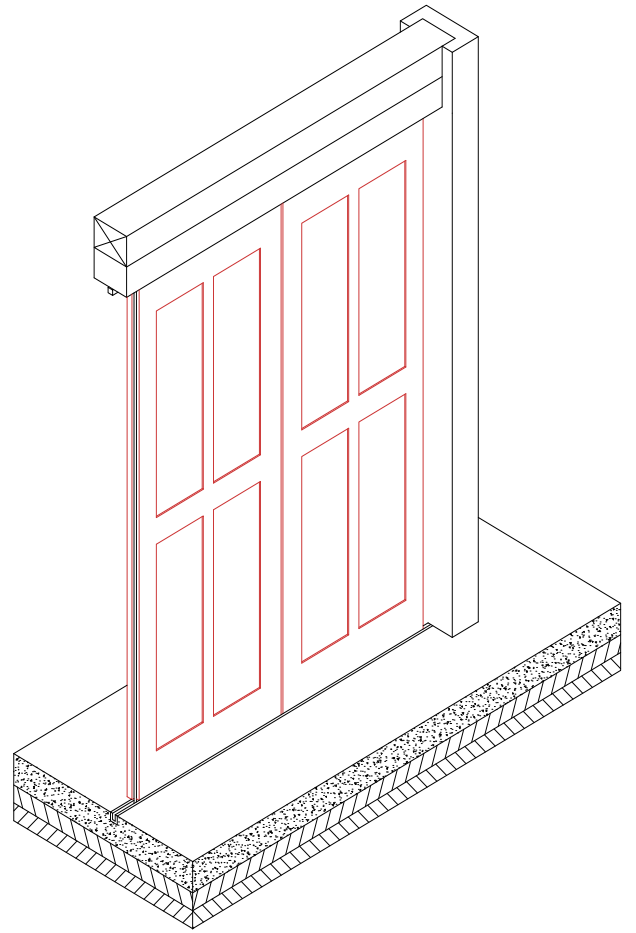
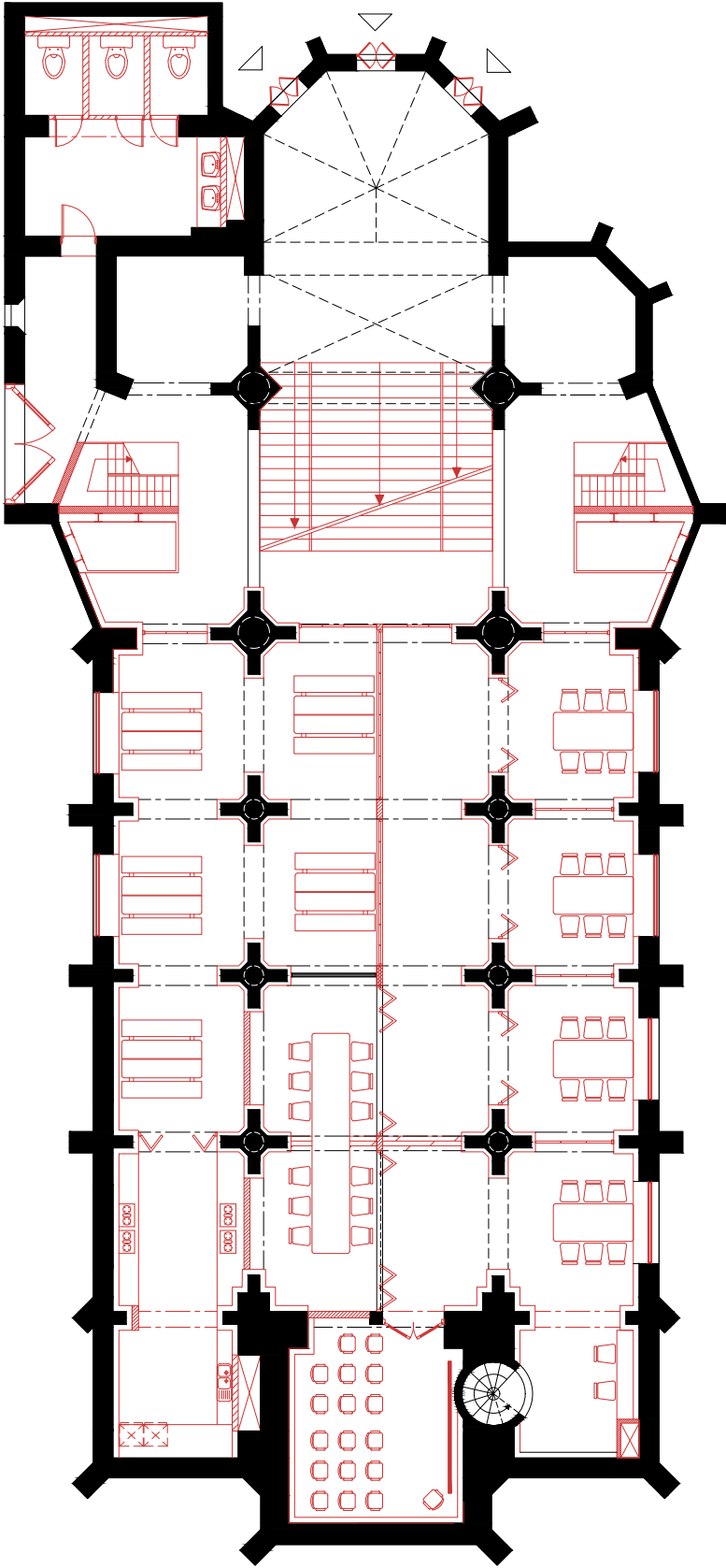

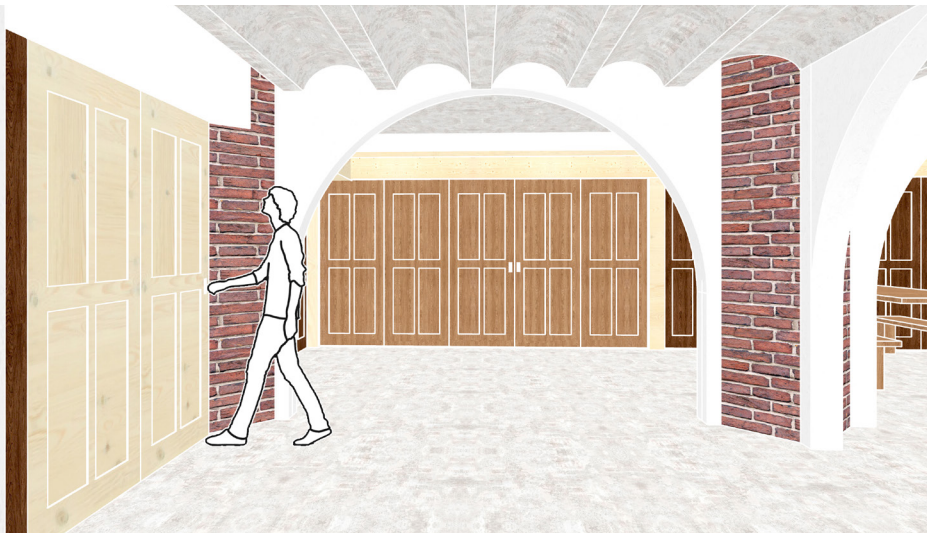

Collapsible Walls

Doors harvested from the rectory and church can be cut to the required size and placed within the channels to create a patchwork of different types of doors.

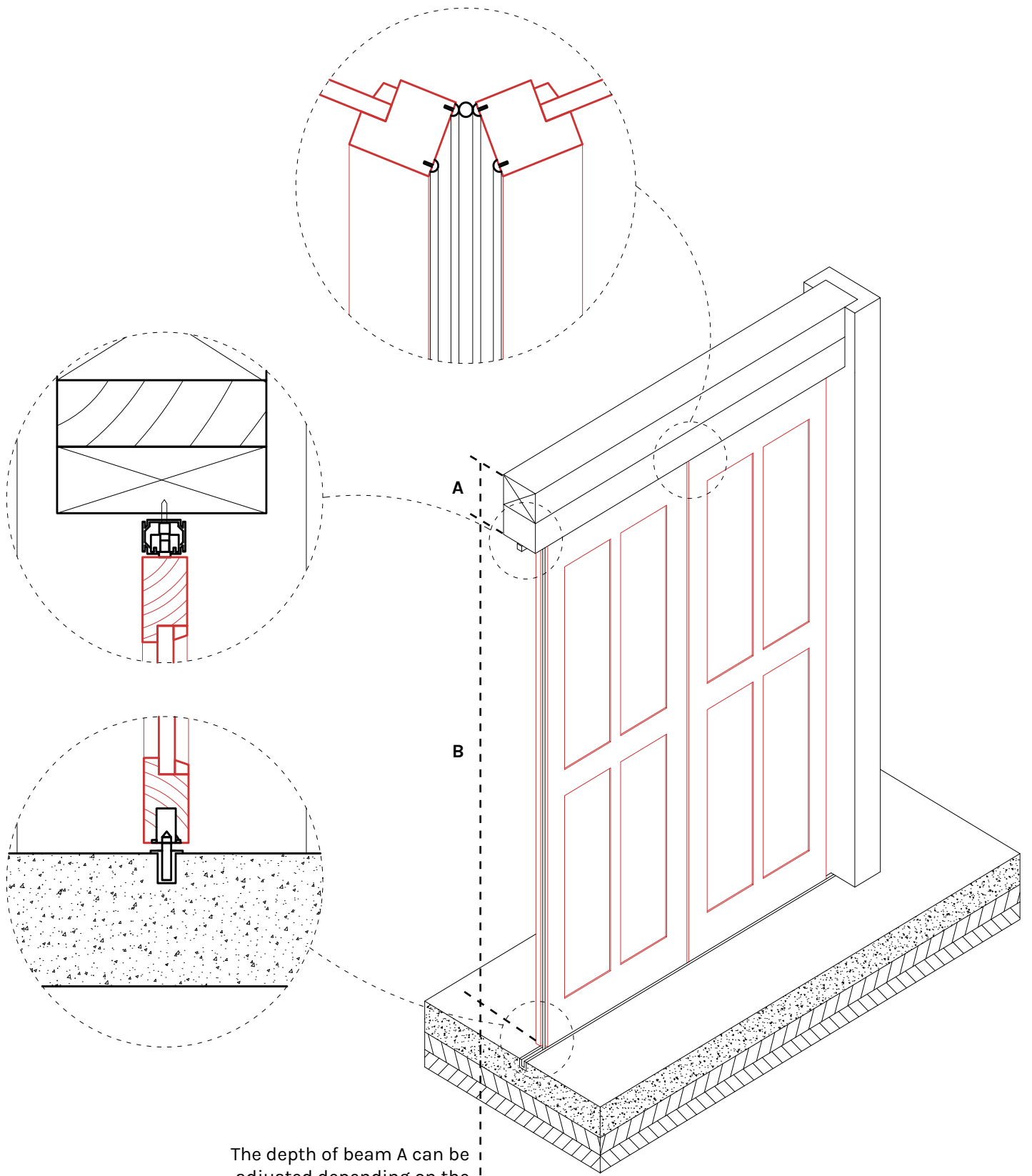

The depth of beam A can be adjusted depending on the height of the door.

Rentable Individual Studios

Motive:

The rectory is converted into a series of studios that vary in size that can be rented by individual artist and craftsmen, This becomes their solitary workspace and

How-to:

The central staircase is maintained. The first and the second floor which used to be the storage space for materials are converted into studios once the materials is used up in the construction process. Any leftover material is shifted to a ground floor storage room. A collection of glass and harvested materials from the church form the dividing walls of the studios.

Undertaken by:

Assembly Team

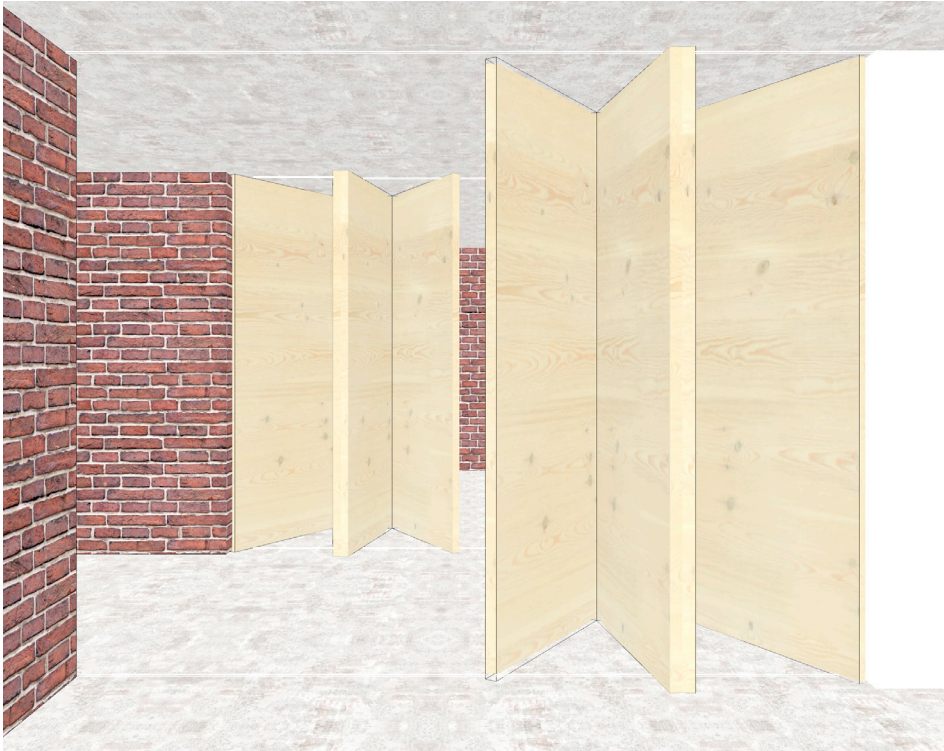

Collapsible Walls

Harvested doors can be cut to the required size and placed within the channels to create a patchwork of different types of doors.



Fabrication space

The ground floor remains a fabrication space with a series of storage units provided alongside the wall for leftover materials

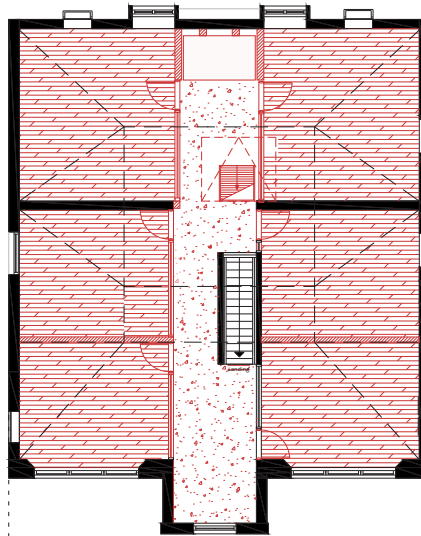

First Floor Plan
Plan 1:200

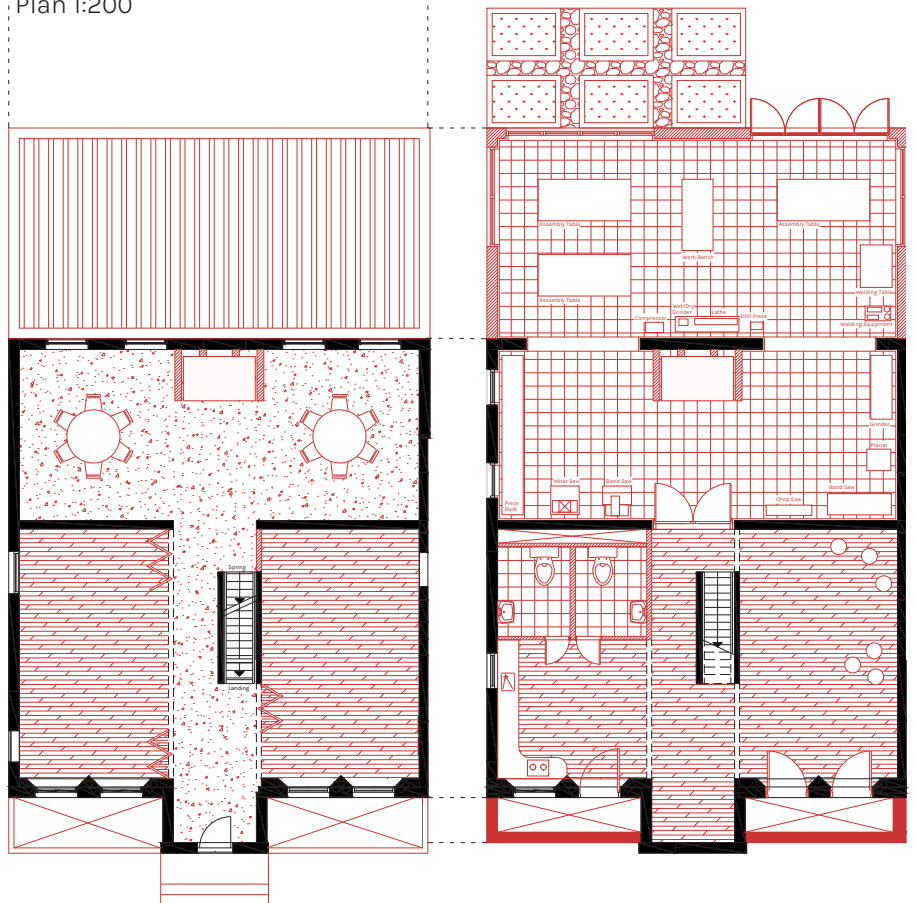

Upper Ground Floor Plan
Plan 1:200

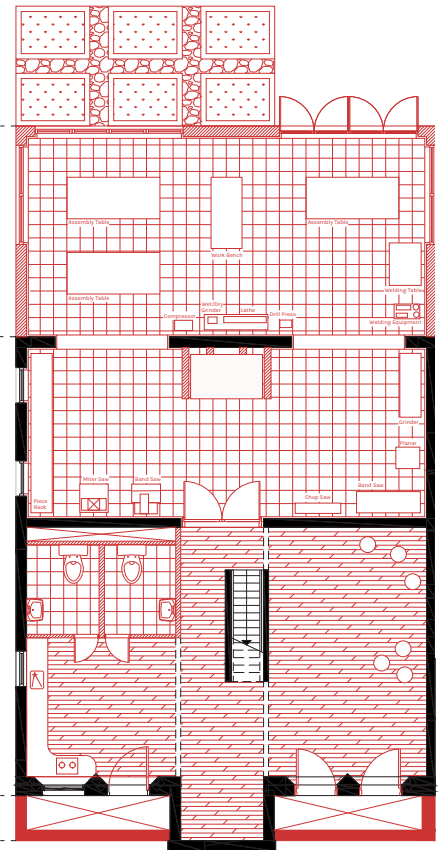

Lower Ground Floor Plan
Plan 1:200

The Exhibition in the Attic and the Tower

Motive:

As the workshops come into a fully functioning state, the attic, which was originally inaccessible to the general public is opened up as an exhibition area. Here the art and crafts created within the workshops can be displayed. Alongside this, paraphernalia from the church such as statues and paintings are placed in the tower alongside the bell.

How-to:

The bell is restored and cantilevered under the tower. A series of spruce beams are placed on the existing A-frame of the roof and flooring panels are placed on top of it. Plywood walls following the same configurations the workshops are placed between the A-Frames.

Undertaken by:

Assembly Team

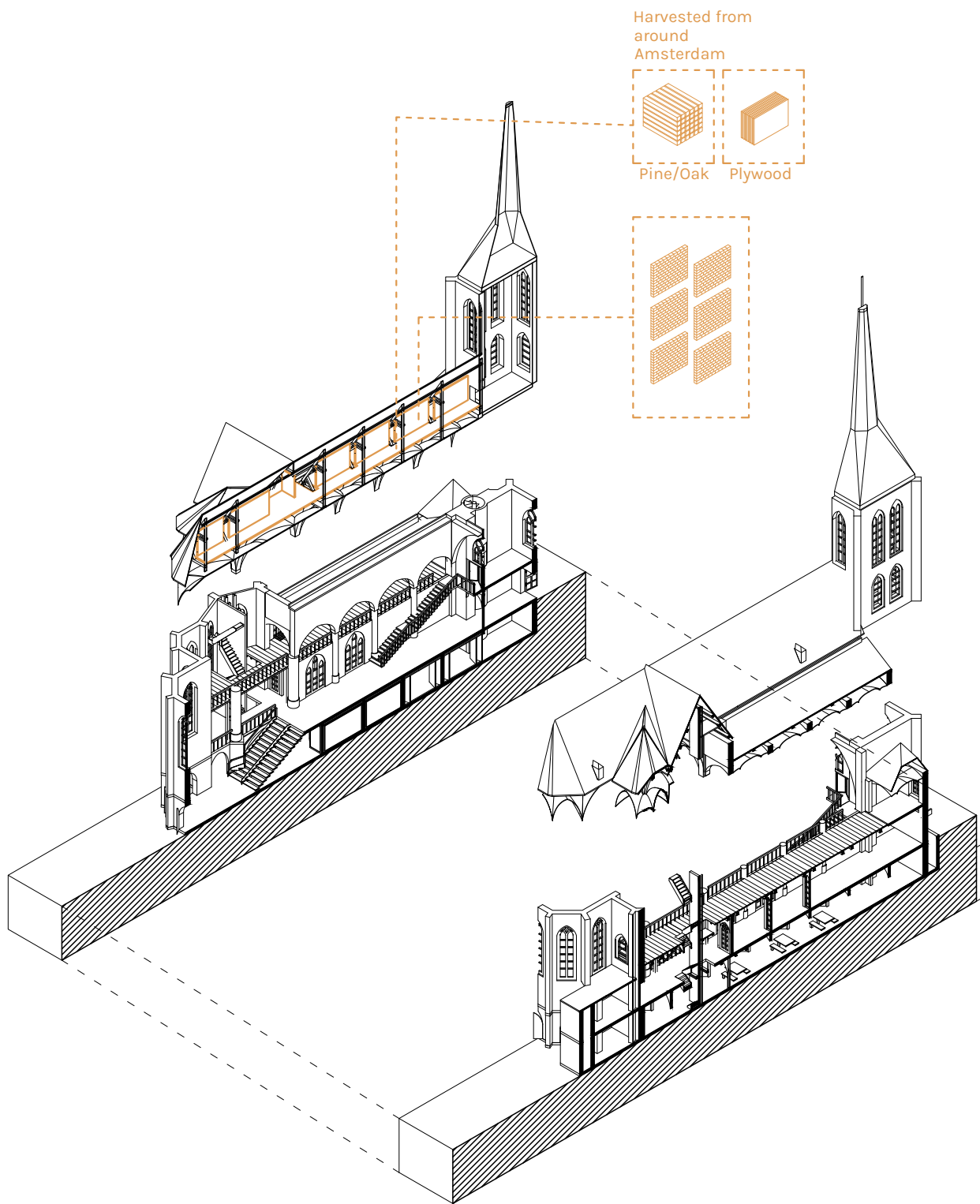

Stage 14:
Exhibition in the Attic and Tower
Undertaken by:
Assembly Team

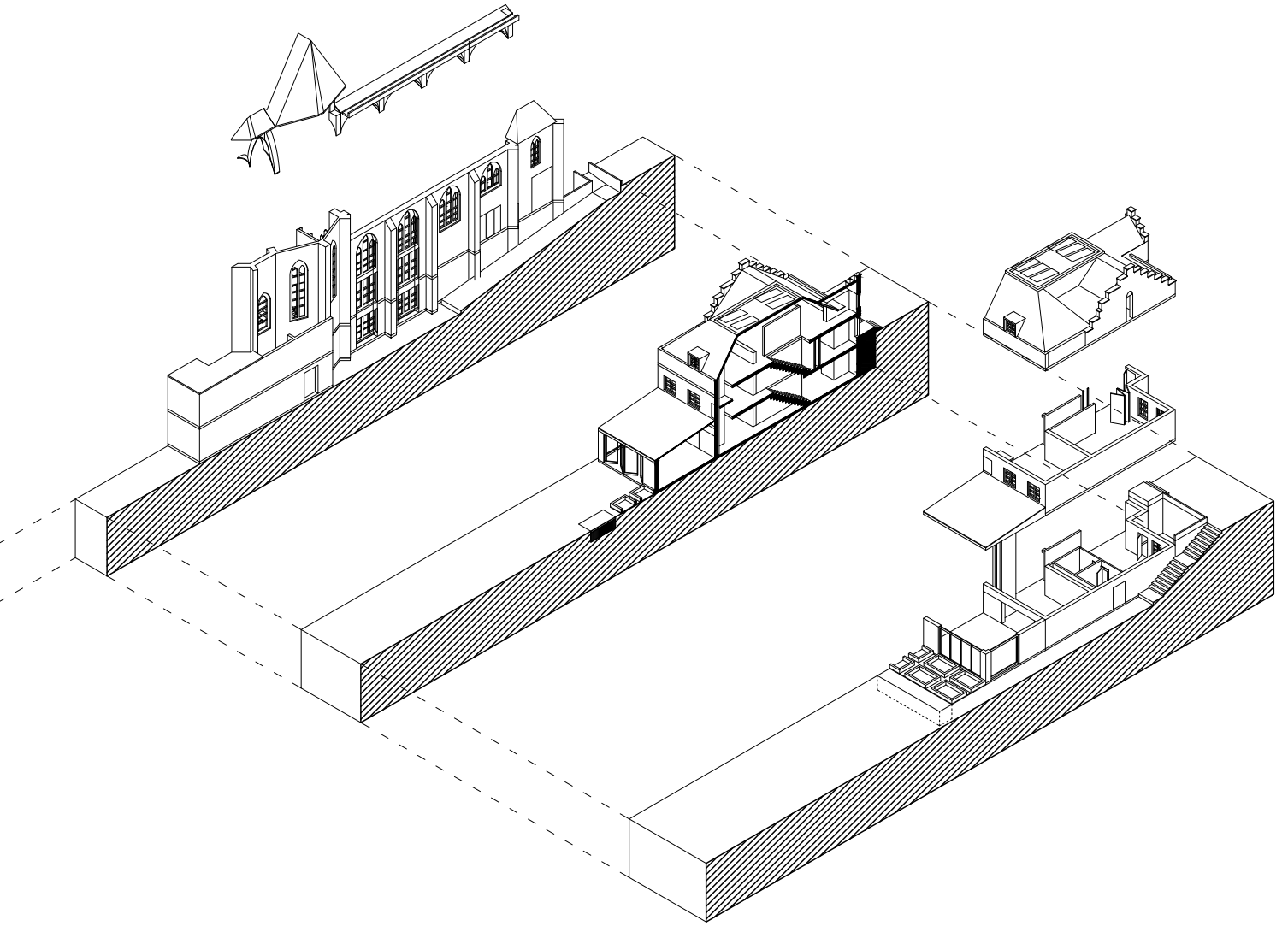

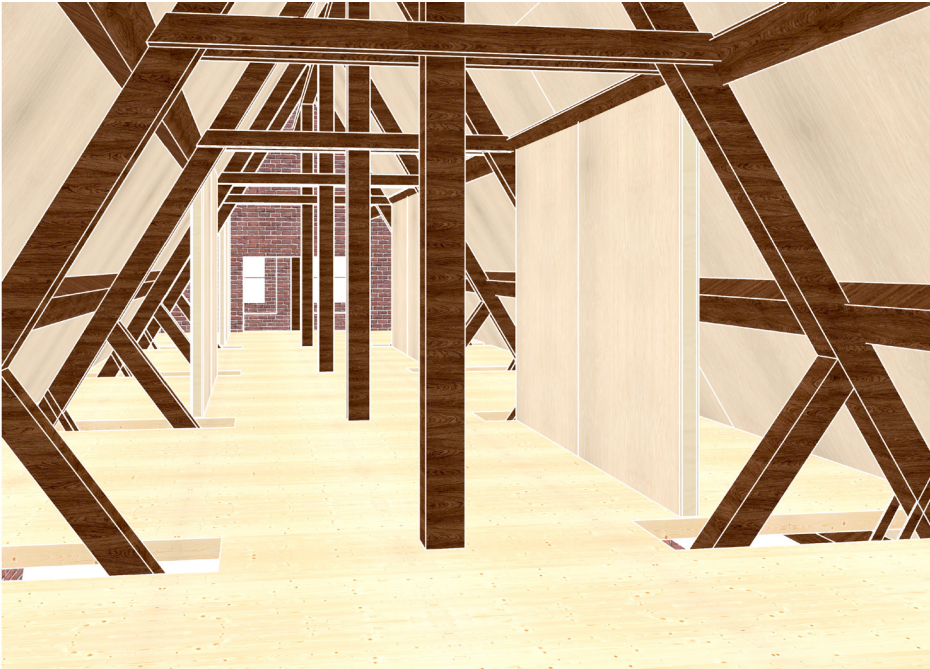

The exhibition

The attic becomes a public space and foot traffic is created by a regular rotation of products being created in the workshops

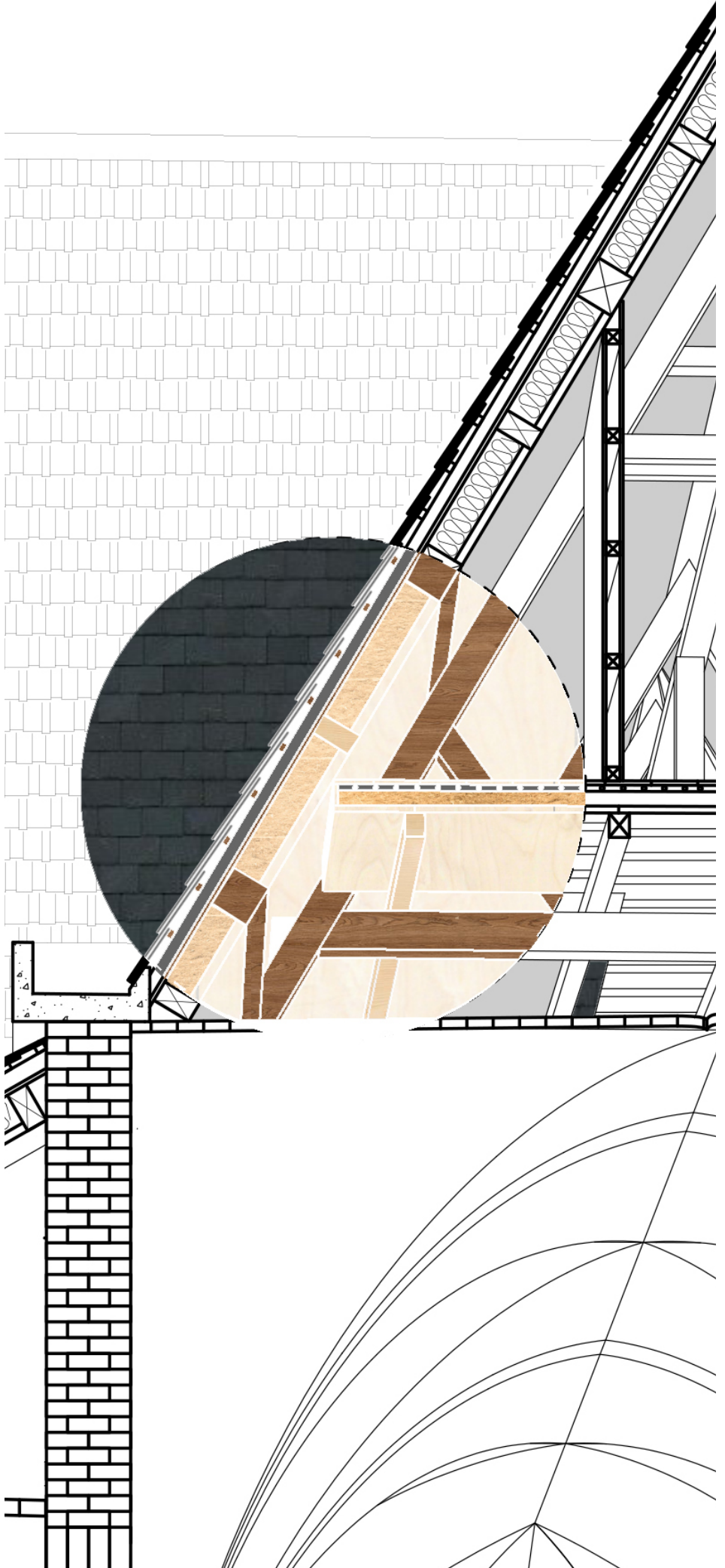

1

Rafters are placed on the existing A-frame to form the base support structure.

2

Floor (Configuration 2) is placed on the rafters as the walkable surface.

3

Wall (configuration 2) are placed within the A-Frames, vertically for display of arts and crafts.

Appendix

Set of Drawings (Plans and Elevations)

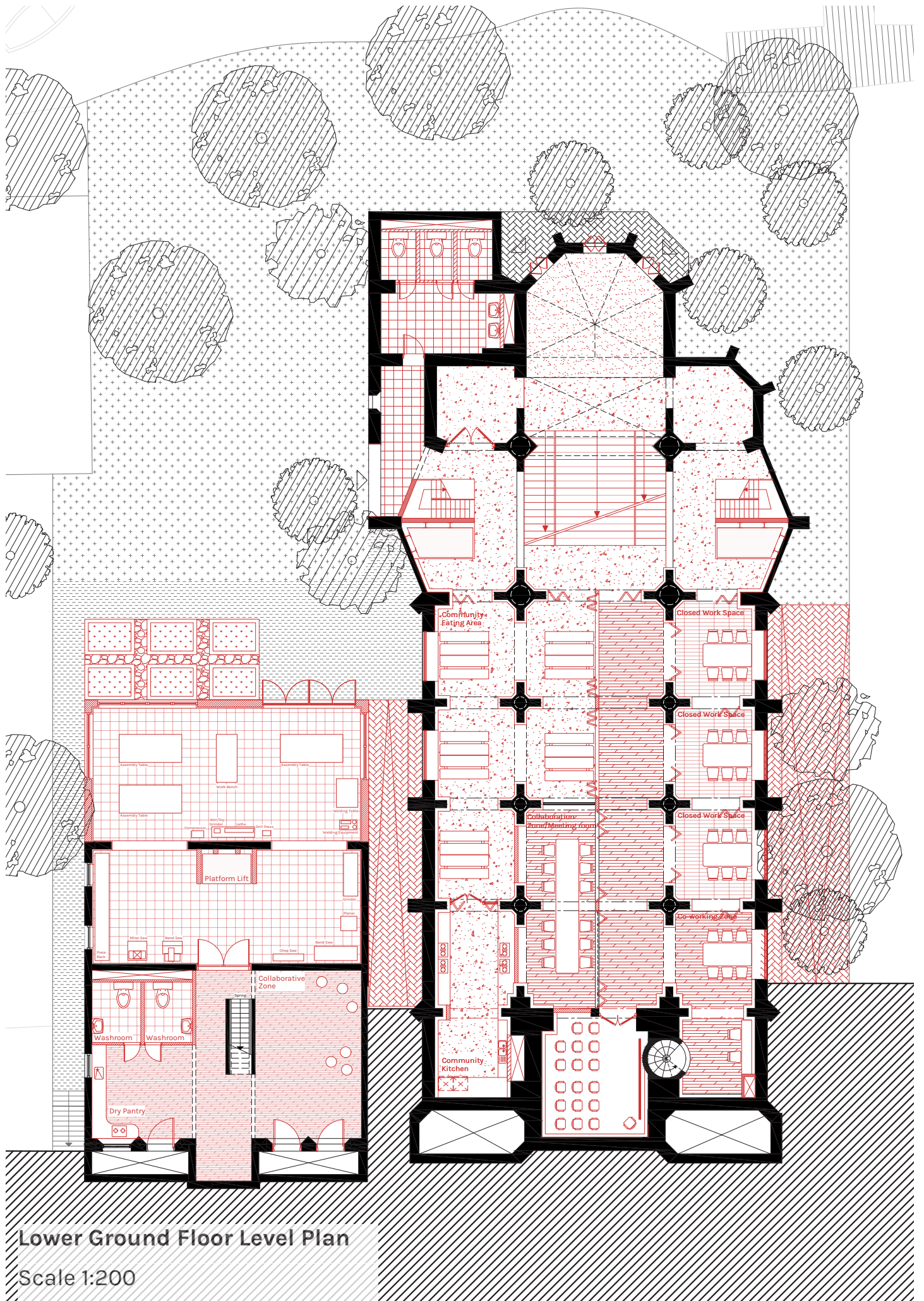

Lower Ground Floor Level Plan

Scale 1:200

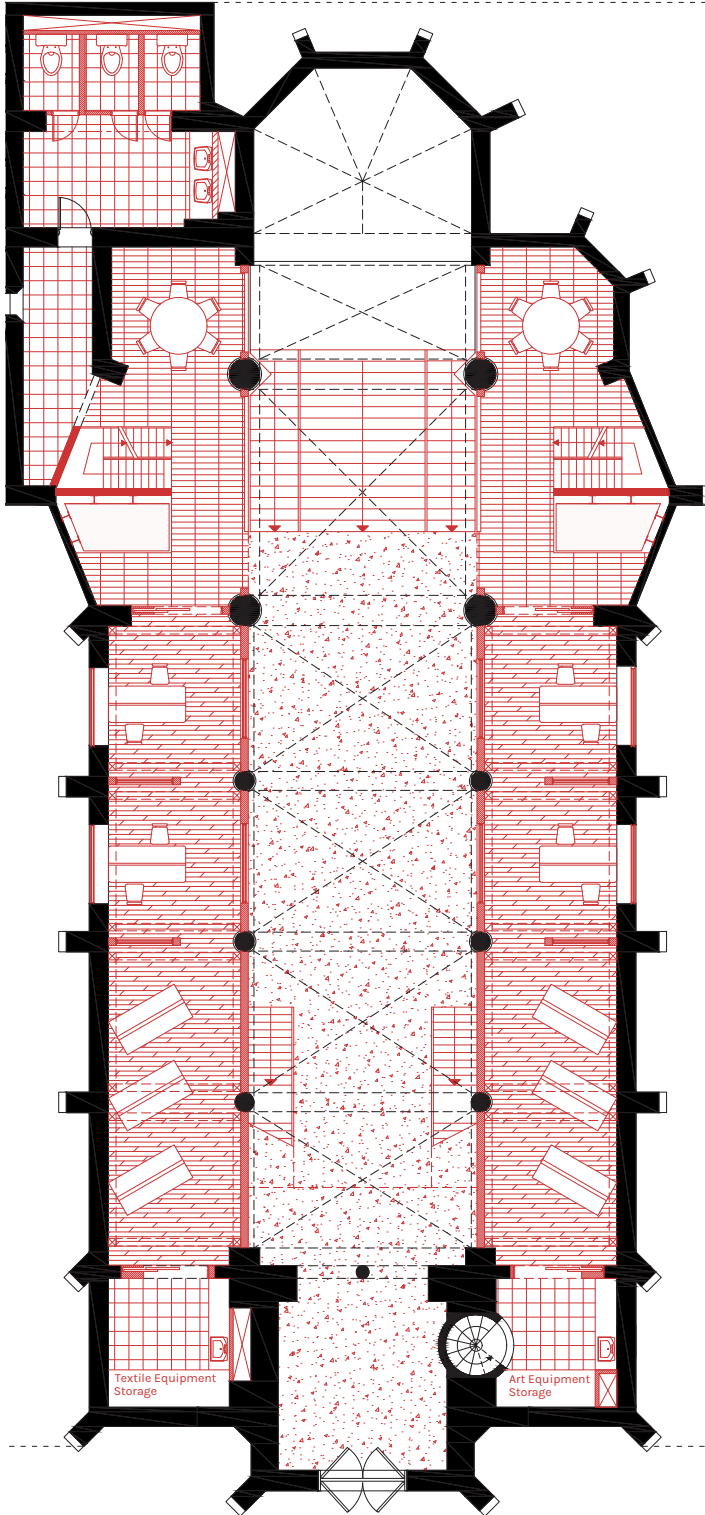

Upper Ground Floor Level Plan

Scale 1:200

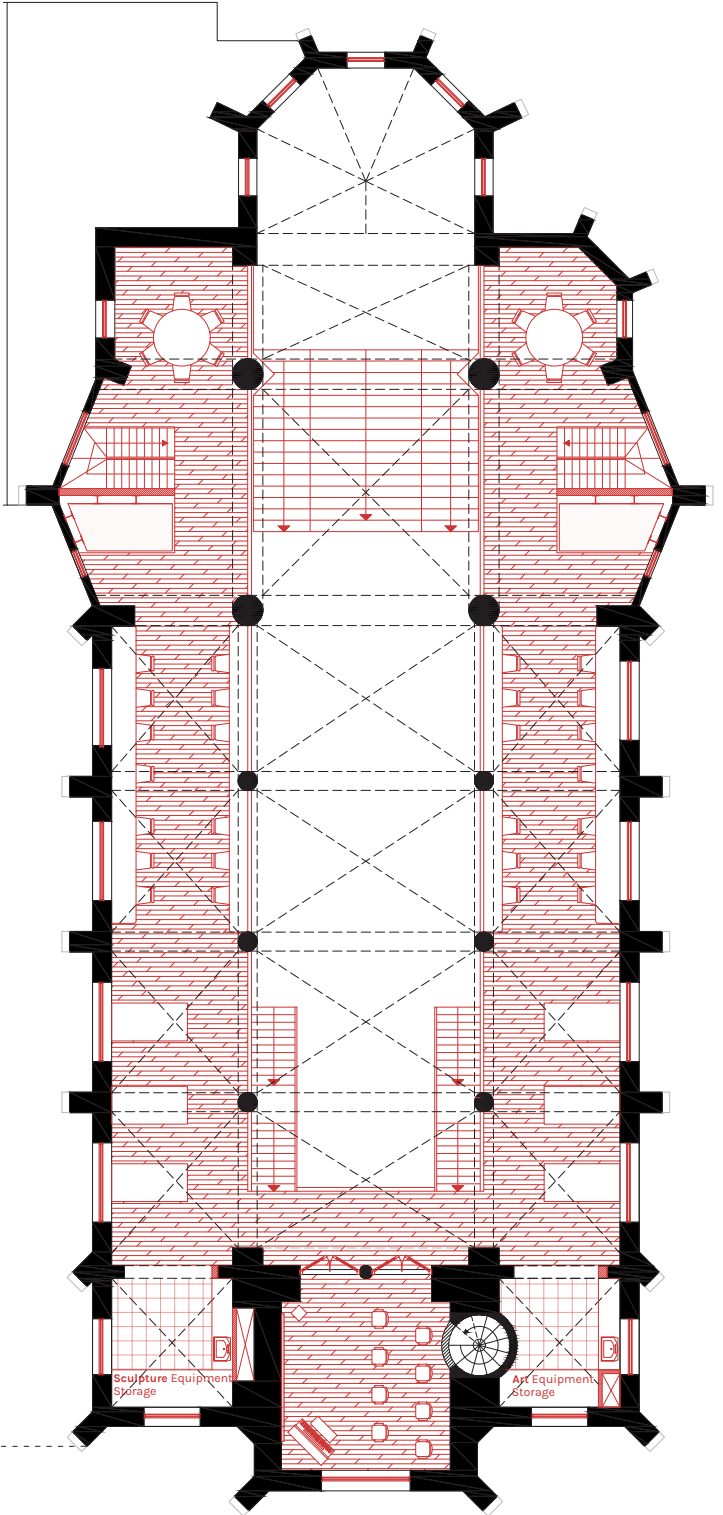

Mezzanine Level Plan

Scale 1:200

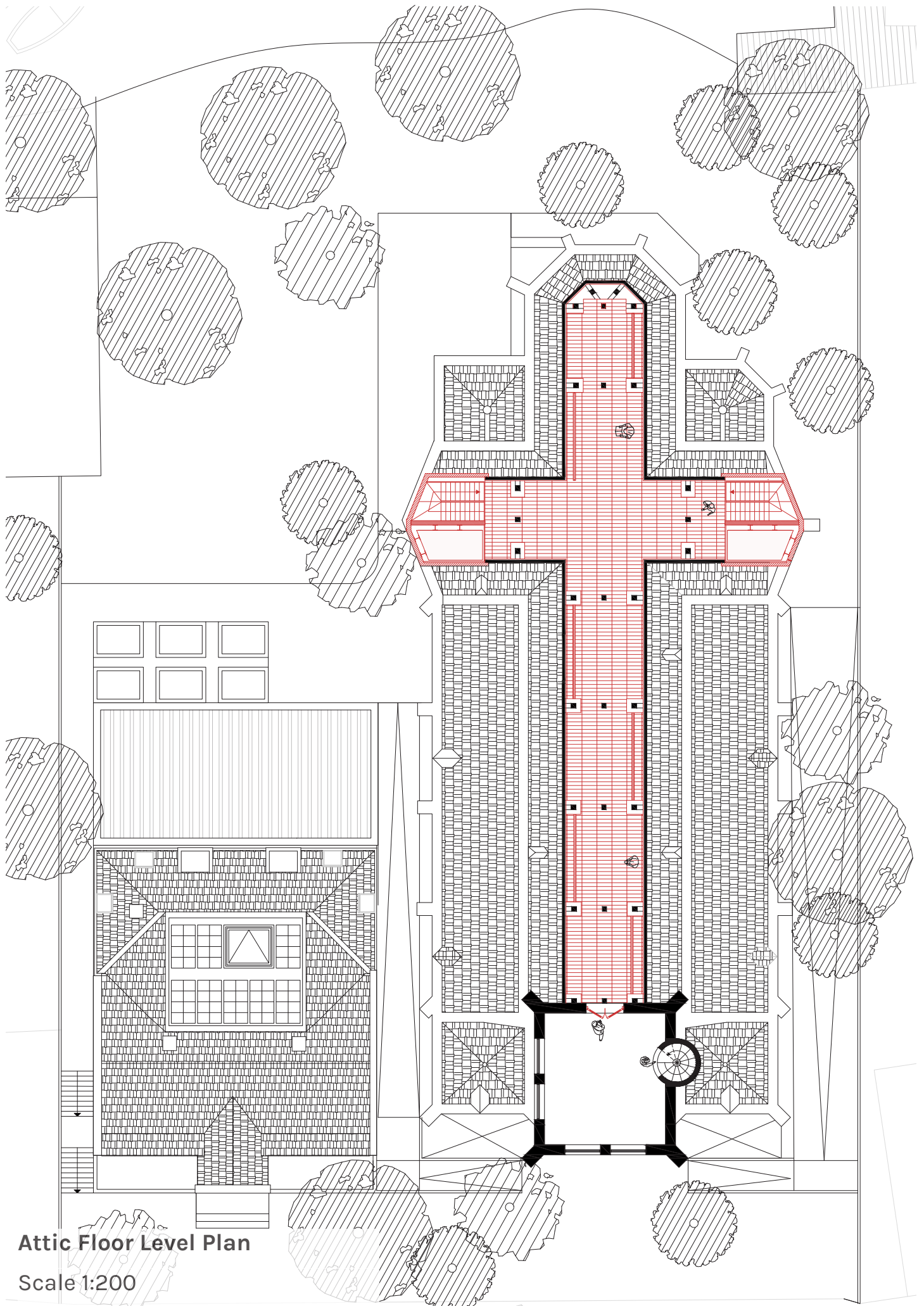

Attic Floor Level Plan

Scale 1:200

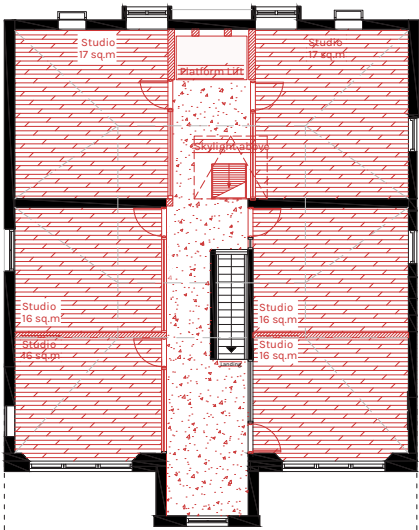

First Floor

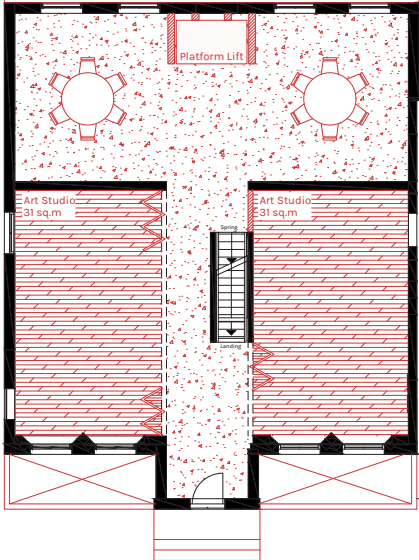
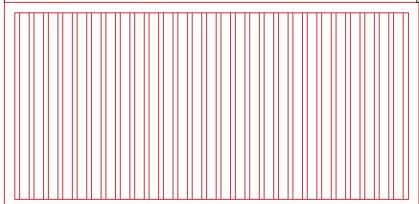

Upper Ground Floor

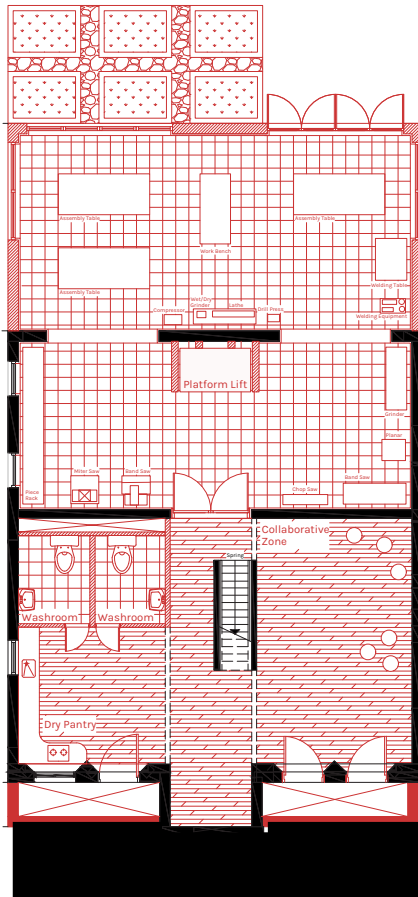

Lower Ground Floor

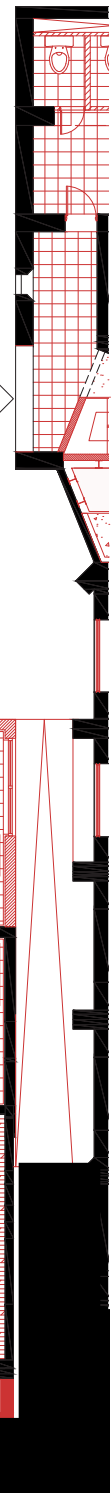

Rectory Plans Level Plan

Scale 1:200

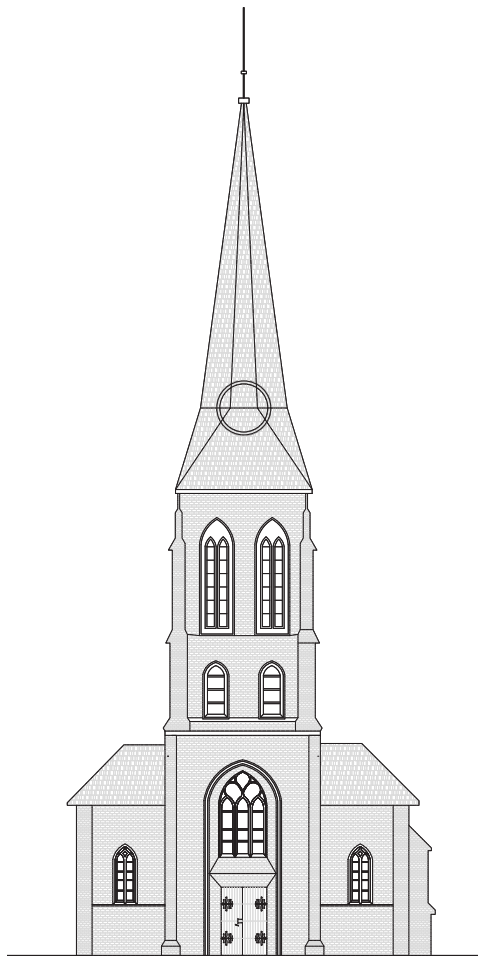

South Elevation

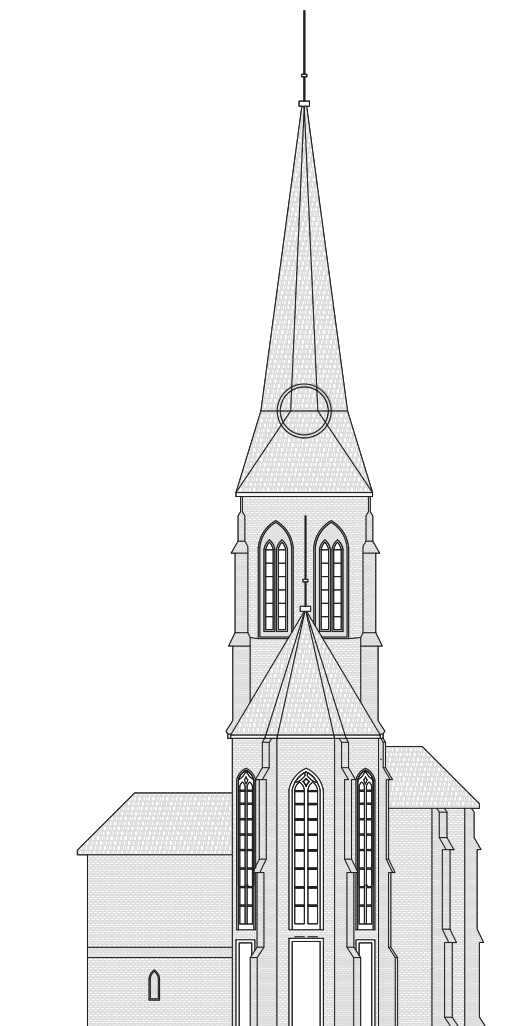

North Elevation

Elevations

Scale 1:200

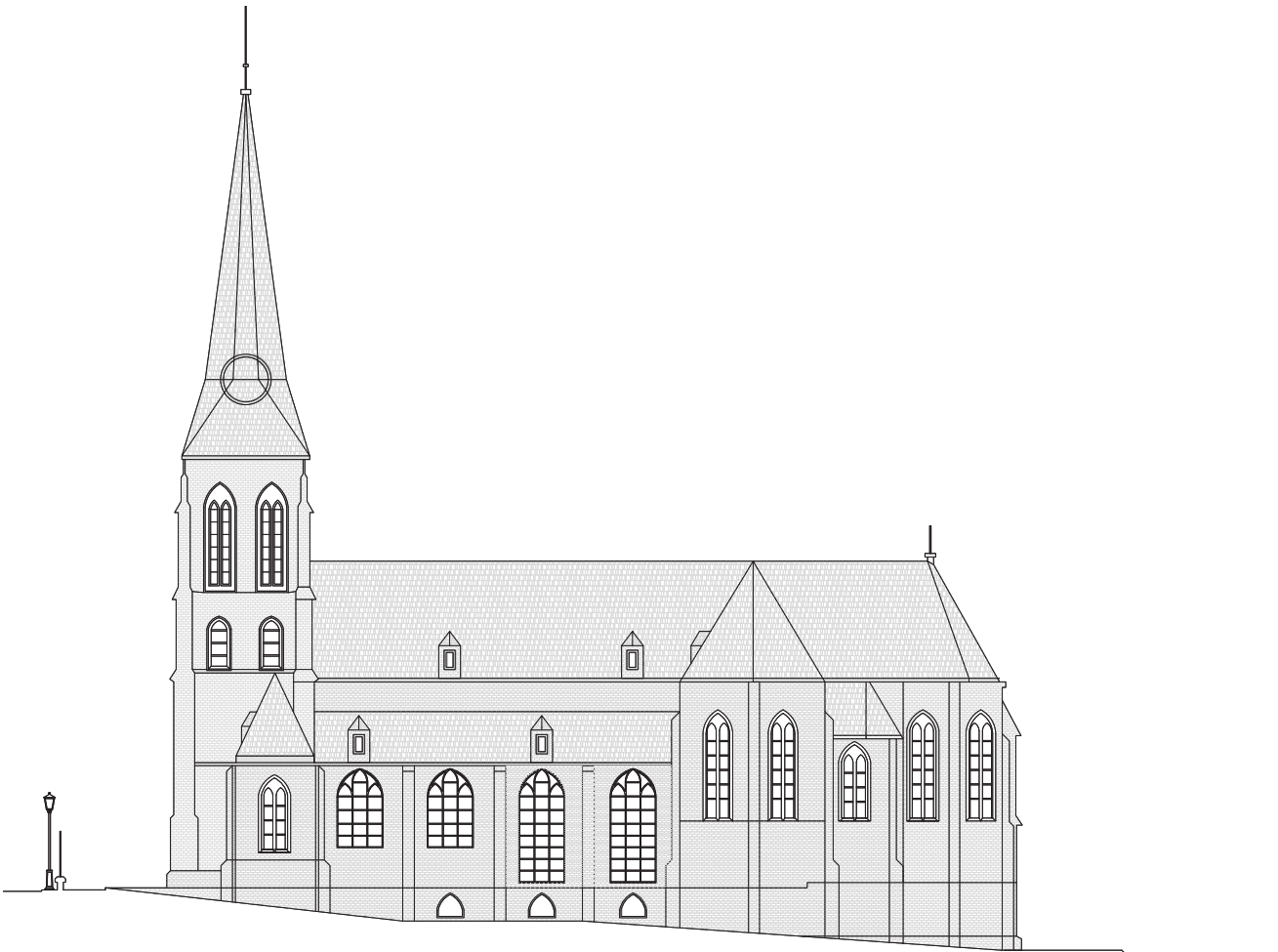

East Elevation



West Elevation