



**Een toepassing van shape grammar in het
ontwerpproces van een Montessori lyceum
in Amersfoort**

Afstudeerpresentatie

7 november 2014

Nina M. Verkerk
studienummer: 1360450

Explorelab 17

Hoofdmentor
Mentor bouwtechniek
Mentor onderzoek/theorie
Externe geëxamineerde

Ir. R.J. Nottrot
Ir. Y.J. Cuperus
Dr.ir. M.C. Stellingwerff
Ir. D. Vitner

Introductie

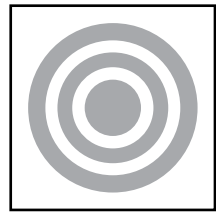

Doel van de opdracht

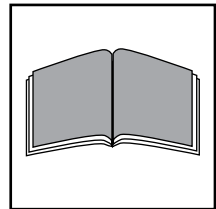

Theoretische achtergrond

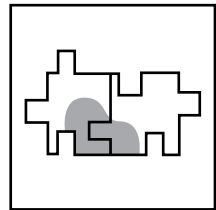

Koppeling theorie en ontwerp

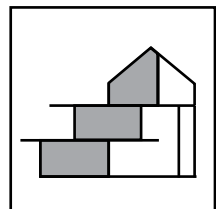

Beschrijving van het architectonisch ontwerp

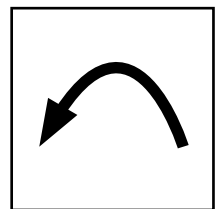

Terugkoppeling



Robie house - Frank Lloyd Wright (1909)

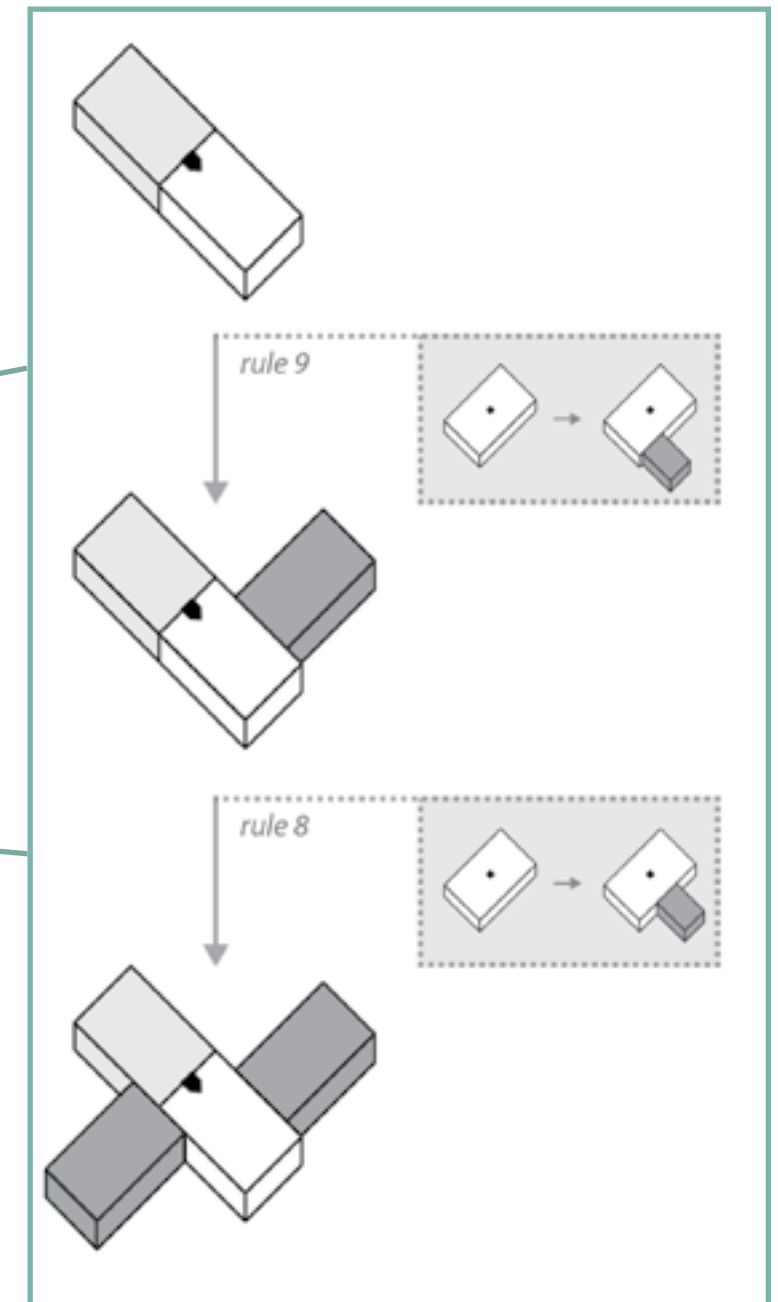
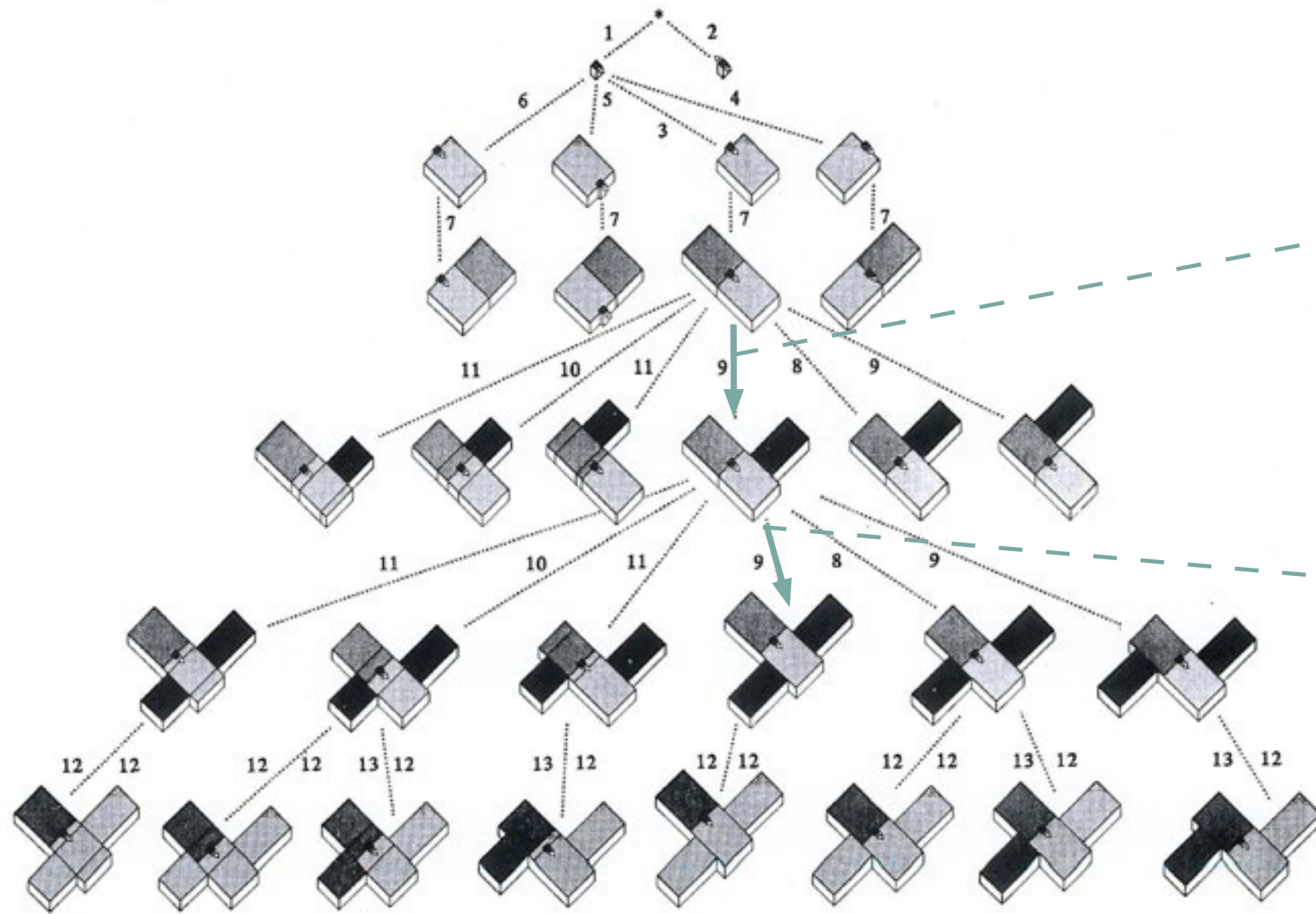

Prairy house grammar - Koning & Eizenberg (1981)

Doel

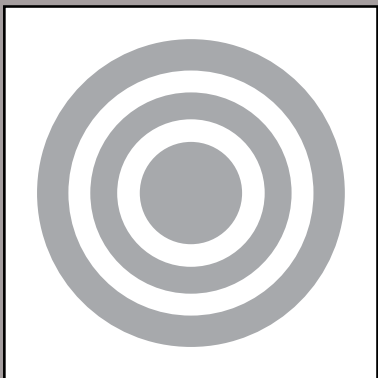

Doelstelling

Shape grammar gebruiken in het ontwerpproces **zonder een specifieke stijl te extraheren.**

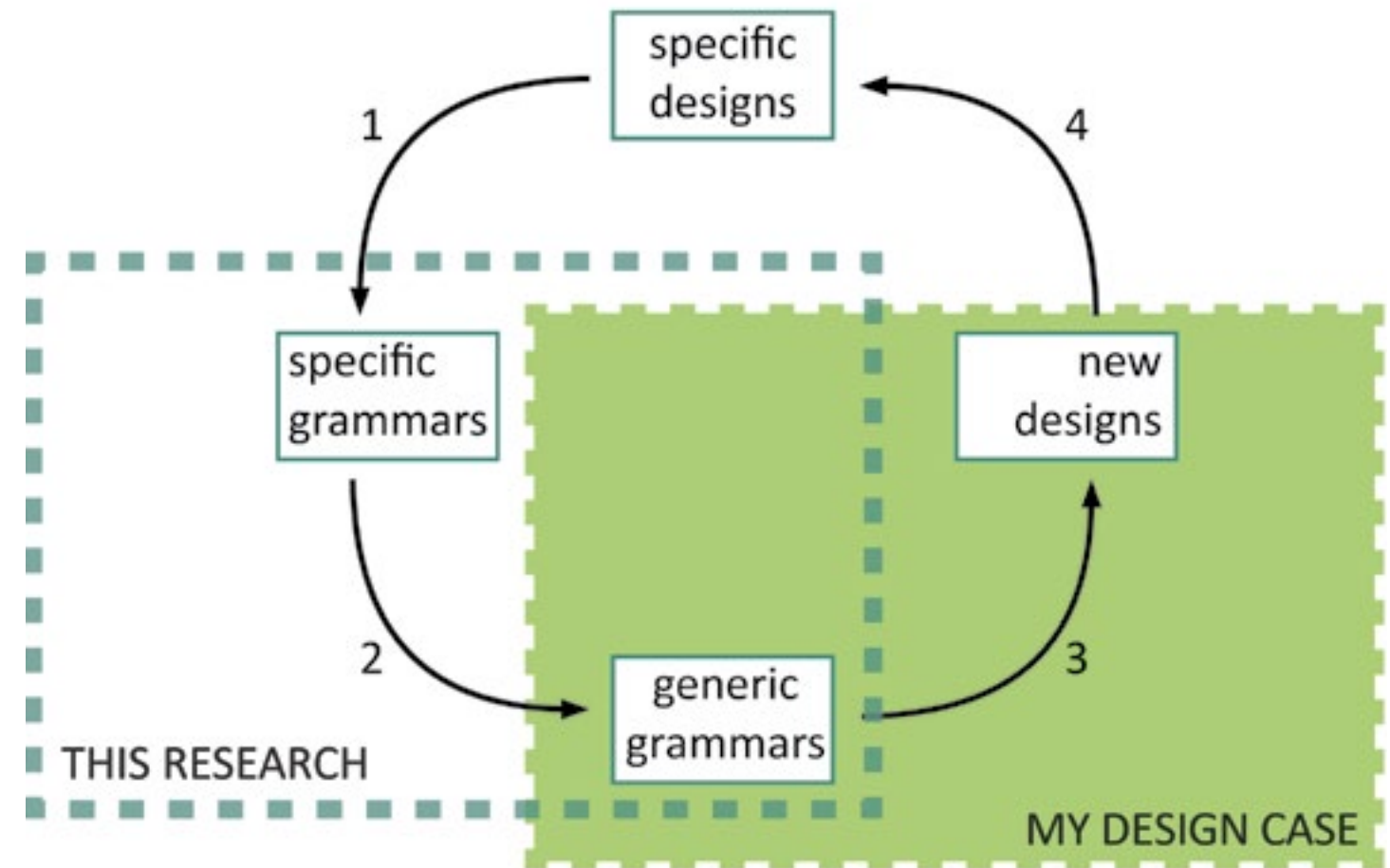

Onderzoeksvraag

In hoeverre kan een generiek begrip en een algemeen systeem van shape grammar toegepast worden in het architectonisch ontwerpproces?

Onderzoeksstructuur

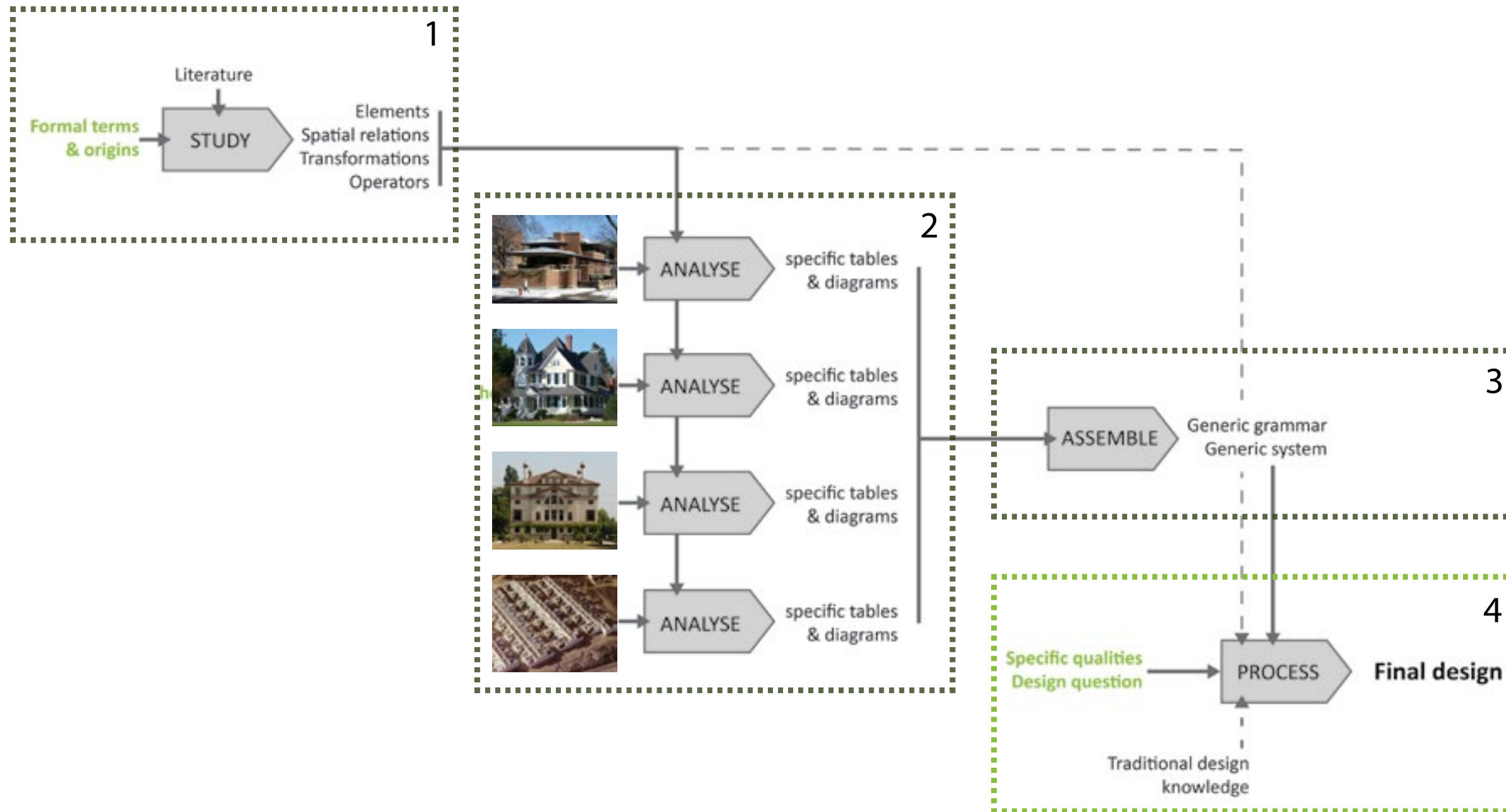

Theorie

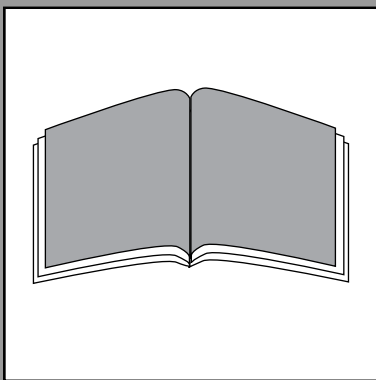

1. Een stukje theorie

Regels

Transformaties

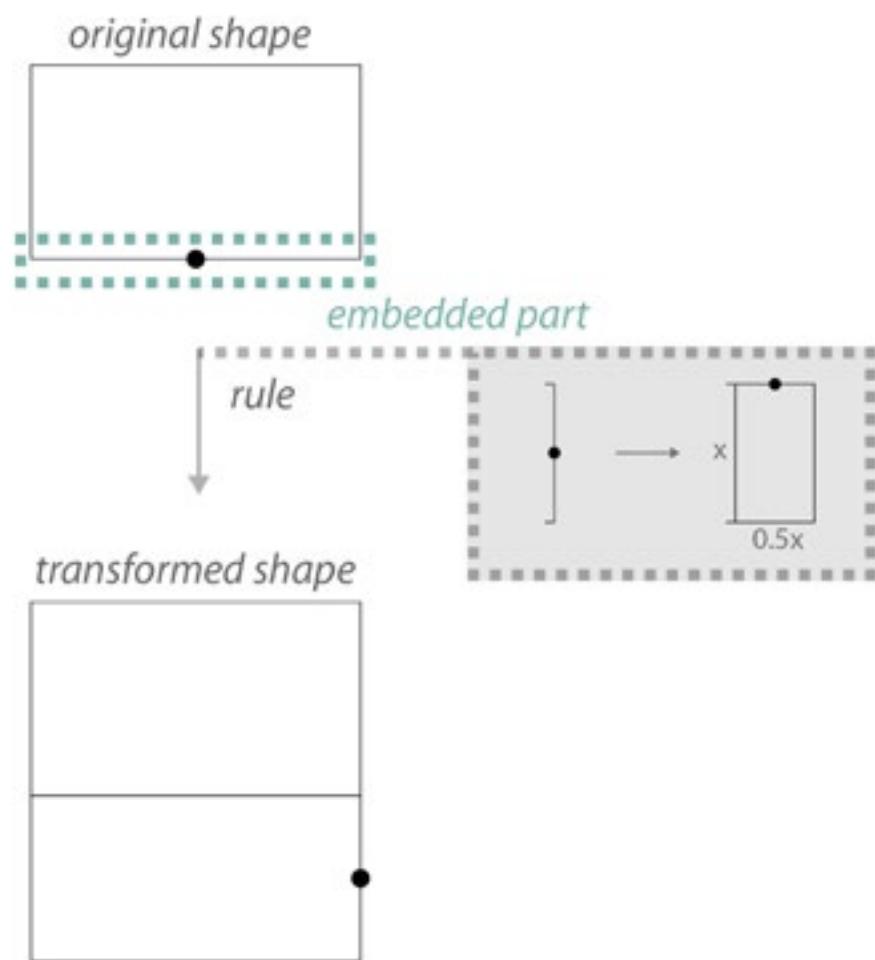

1. Een stukje theorie

Additie

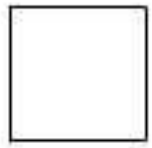

Transformeren van een grid



Verdelen van een vlak

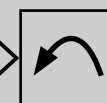
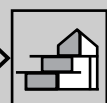
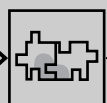
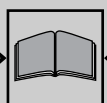

1. Een stukje theorie

toepassing van een voorbeeldregel

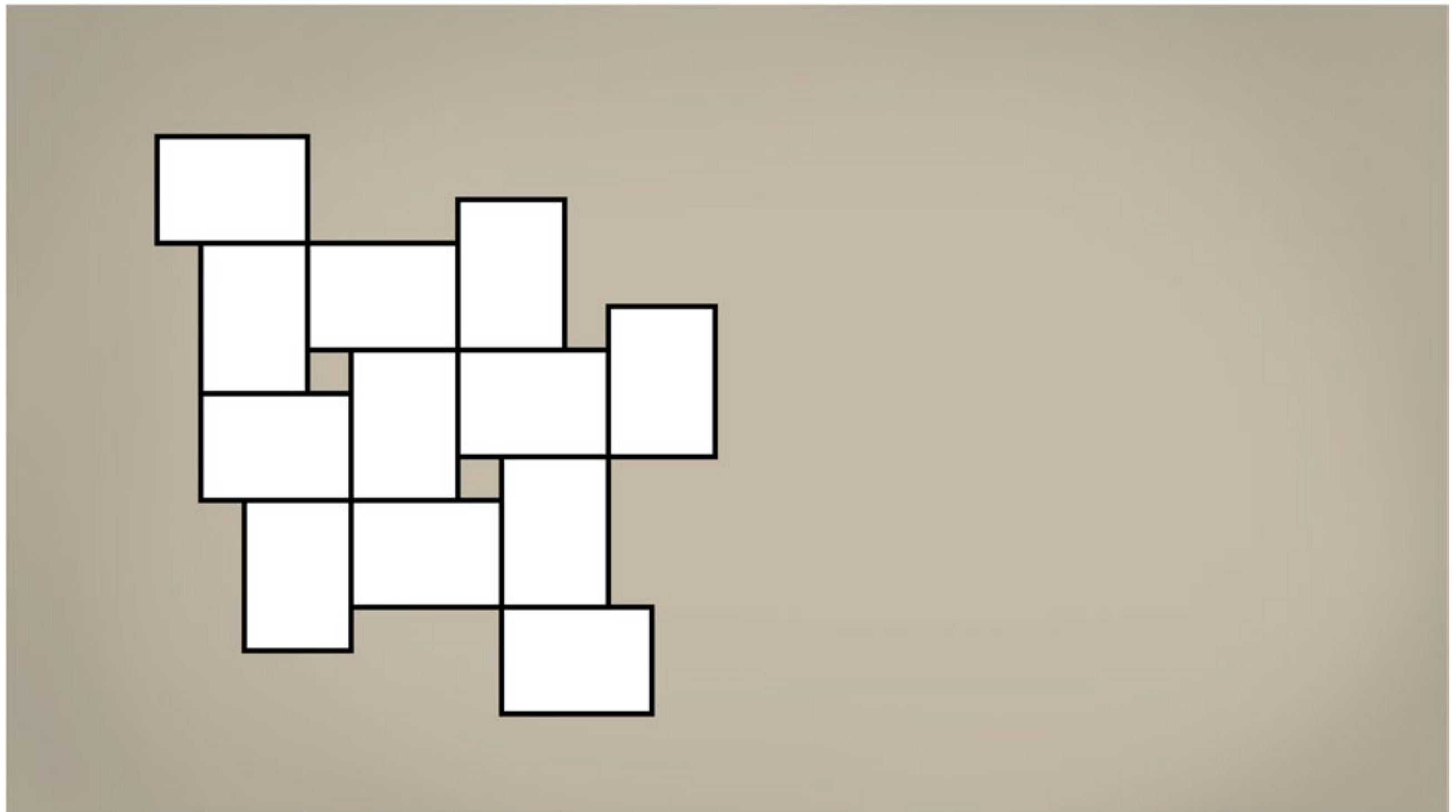
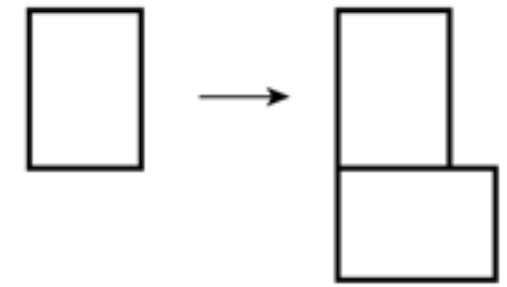

3. Conclusies case studies en formele theorie

- Shape grammar is geen exacte wetenschap
- Niet alle onderdelen van een ontwerp worden beschreven
↳ alleen onderdelen *specifiek* voor het type gebouw

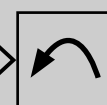
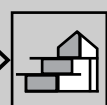
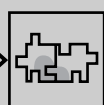
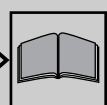

3. Conclusies case studies en formele theorie

- Shape grammar is geen exacte wetenschap
- Niet alle onderdelen van een ontwerp worden beschreven
↳ alleen onderdelen *specifiek* voor het type gebouw

Indeling van de woonruimtes

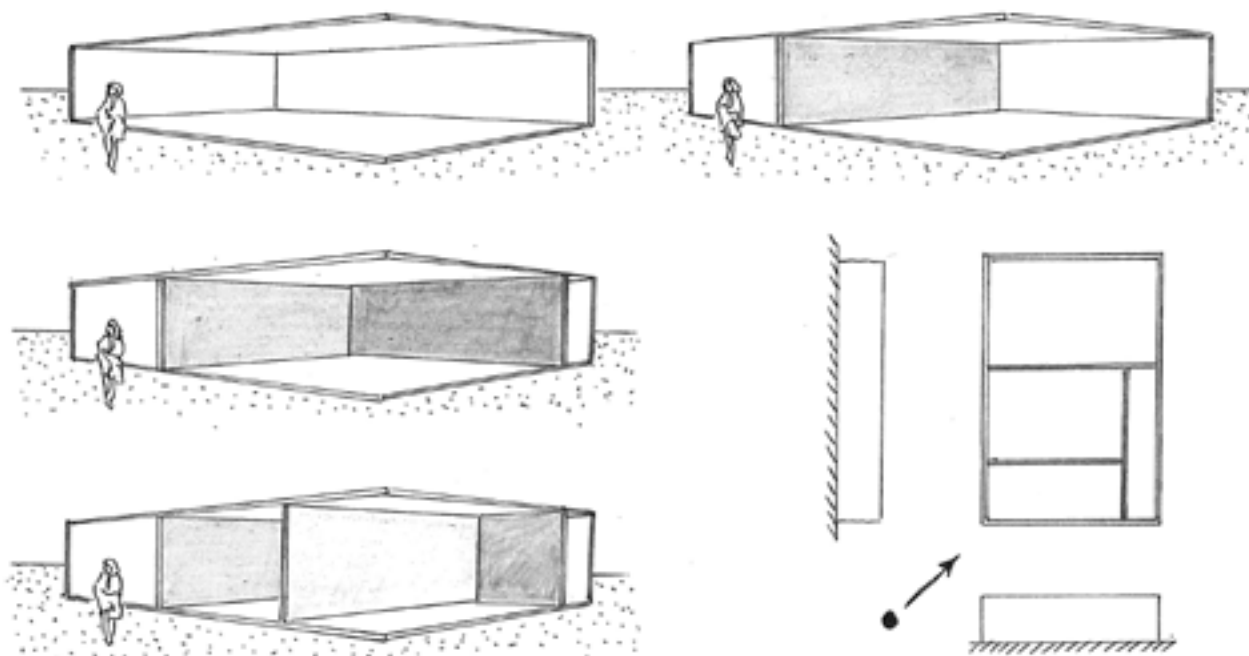

Woningen in Malagueira (Siza), grammatica door J.P. Duarte (2005)

Toevoeging van het portiek

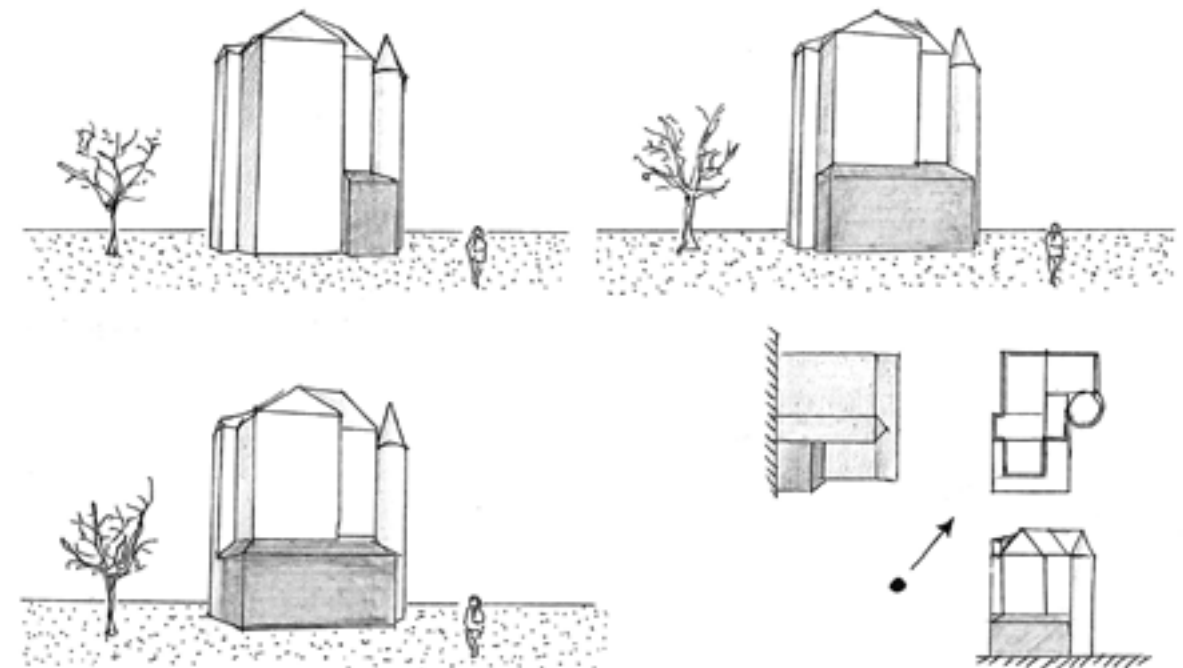

Queen Anne woningen, grammatica door Flemming (1987)

3. Conclusies case studies en formele theorie

- Shape grammar is geen exacte wetenschap
- Niet alle onderdelen van een ontwerp worden beschreven
↳ alleen onderdelen *specifiek* voor het type gebouw
- Stages en sub stages

1. Basis compositie



2. Specifieke onderdelen

Koppeling theorie en ontwerp

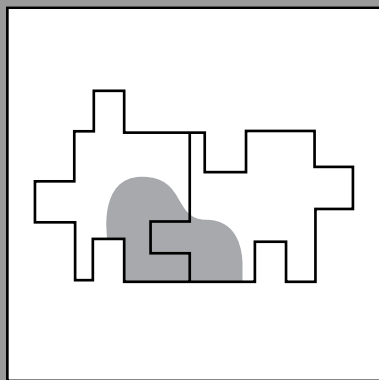

4. Implementatie in het ontwerpproces

1. Metaniveau (structuur)

2. Inhoudelijk niveau

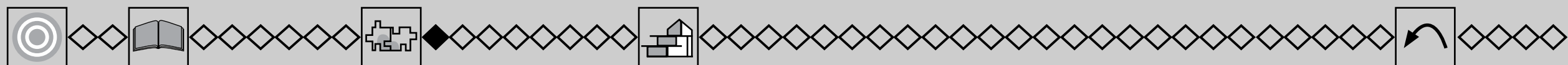

4. Implementatie in het ontwerpproces

1. Metaniveau (structuur)

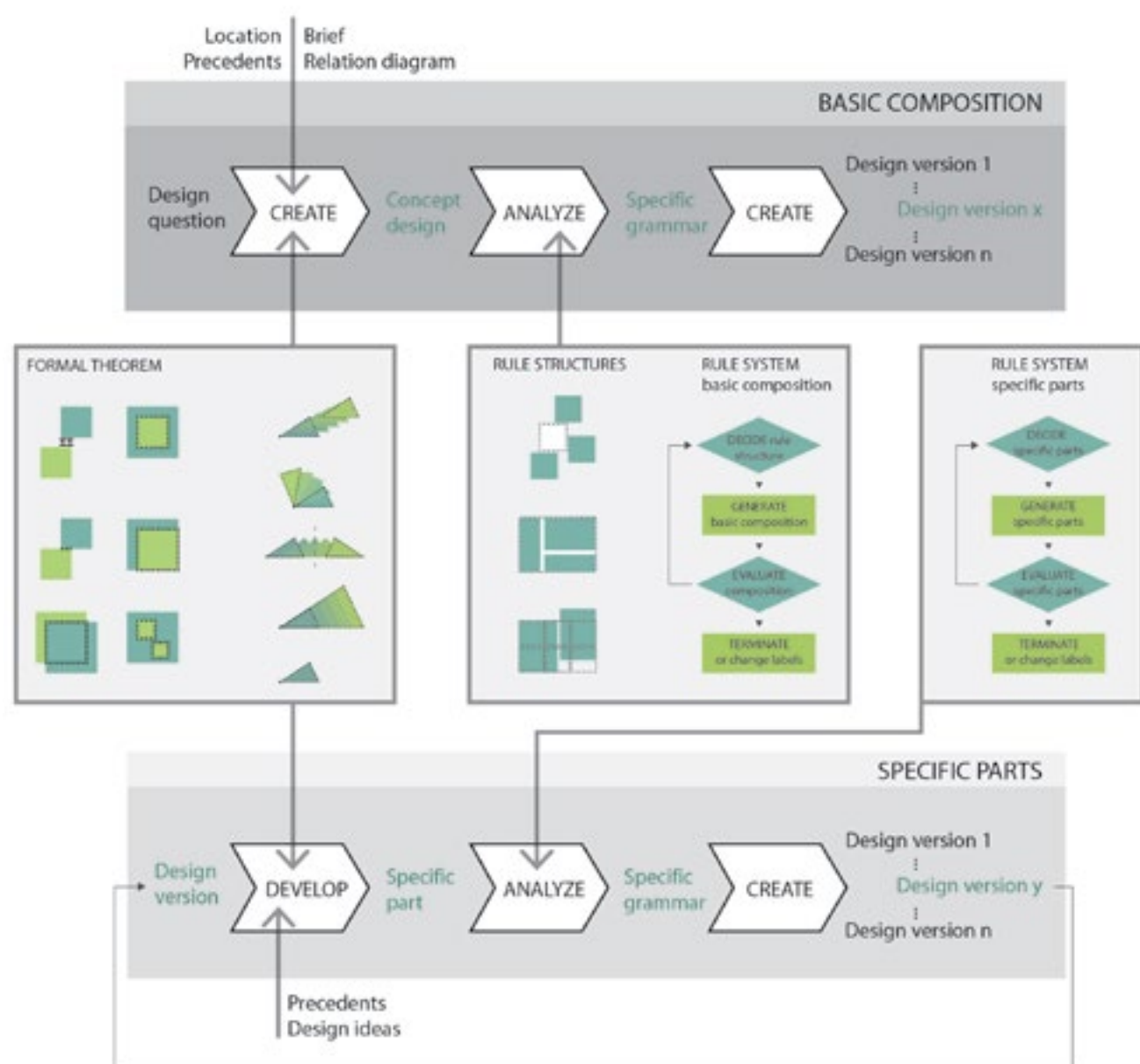

Stap 1: kennis opdoen over het onderwerp
resultaat: artikel

Stap 2: concept ontwerp ontwikkelen
resultaat: tekeningen (2D + 3D), modellen

Stap 3.1: analyseren van het conceptontwerp door middel van grammatica

Stap 3.2: ontwikkelen van een specifieke grammatica
resultaat: specifieke shape grammar

Stap 4: ontwikkelen van het ontwerp op basis van de regels
resultaat: ontwerpvarianten (in dezelfde taal)

Stap 5: ontwikkelen van een aantal specifieke onderdelen

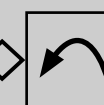
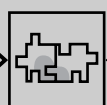
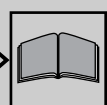

4. Implementatie in het ontwerpproces

2. Inhoudelijk niveau

- Basis compositie



- Doorontwikkelen basis compositie (transformeren van de doorsneden)

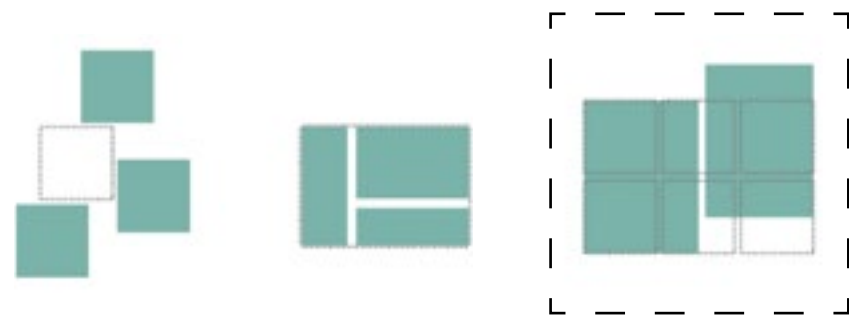

- Specifieke grammatica

Doelen: expliciet maken van de transformaties
consistent ontwerp

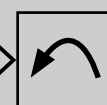
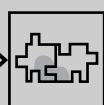
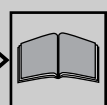

Inhoudelijk - Ontwikkeling van de basis compositie

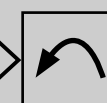
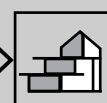
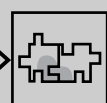
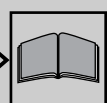
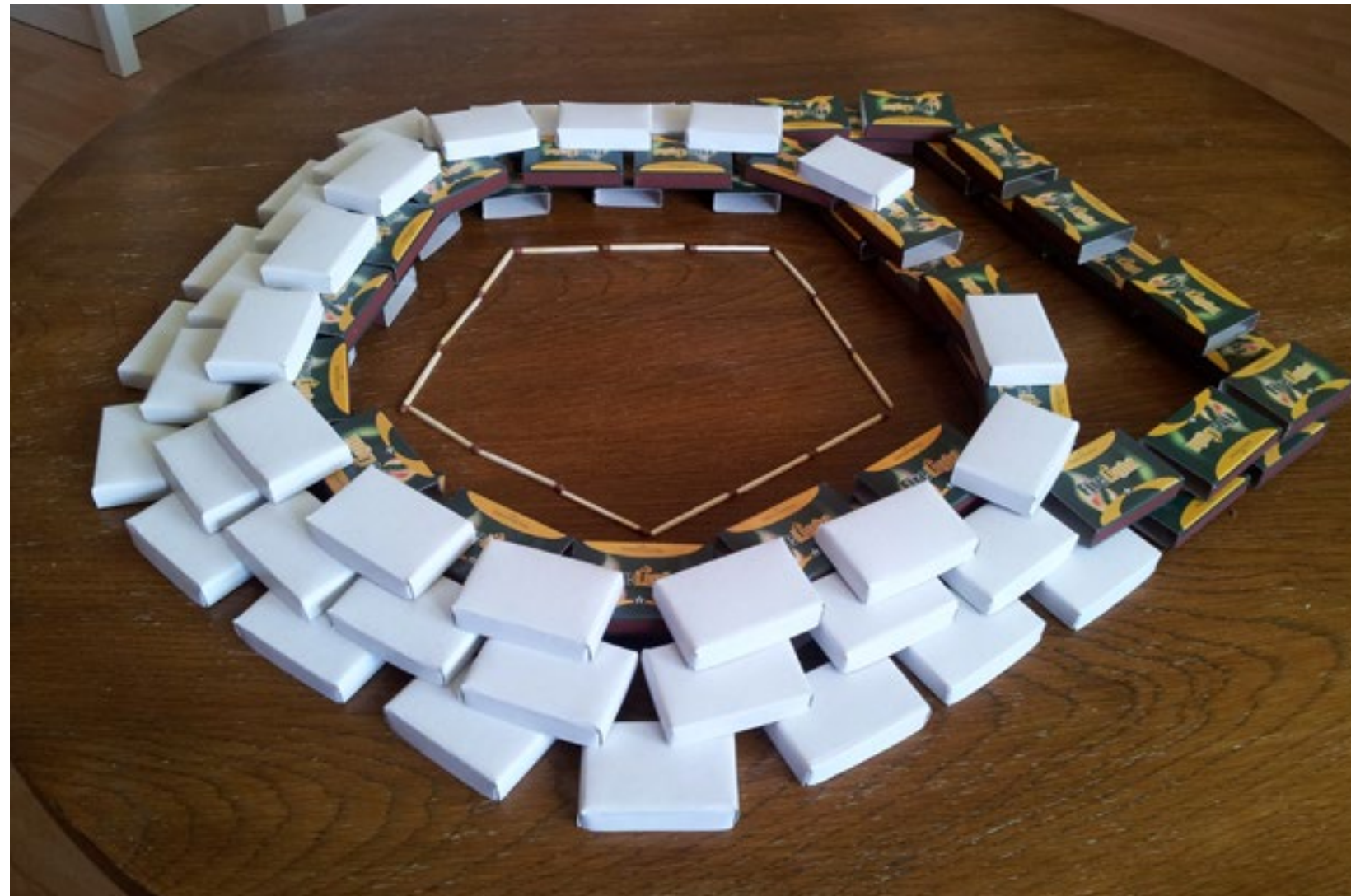

Inhoudelijk - Ontwikkeling van de doorsneden

fase A
definieer grid

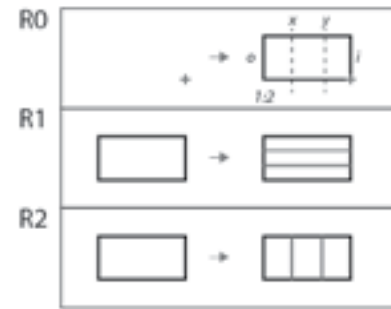

fase C
ontwerpvarianten

aanpassen van het grid



lokalisatie van de buitenruimte

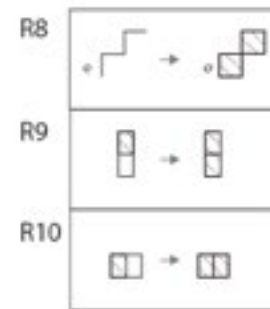

lokalisatie van de klaslokalen



verwijder overbodige lijnen



fase D
constructie en materiaal

introduceer hulplijnen

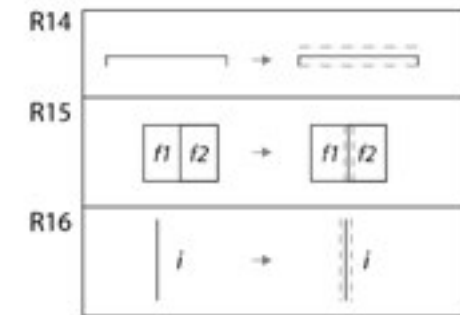

introduceer labels

- 1a: vloer buiten - buiten
- 1b: vloer binnen - buiten
- 1c: vloer binnen - binnen
- 1d: dak
- 1e: vloer binnen - buiten (omgang)

- 2a: wand buiten - binnen
- 2b: wand binnen - binnen
- 2c: wand binnen - buiten (omgang)
- 2d: wand binnen - buiten (binnenplaats)

definieer vloeren

definieer wanden

fase B
algemene deel

lokalisatie van de gang



lokalisatie van de ruimte voor werkplekken



Inhoudelijk - Ontwikkeling van de doorsneden

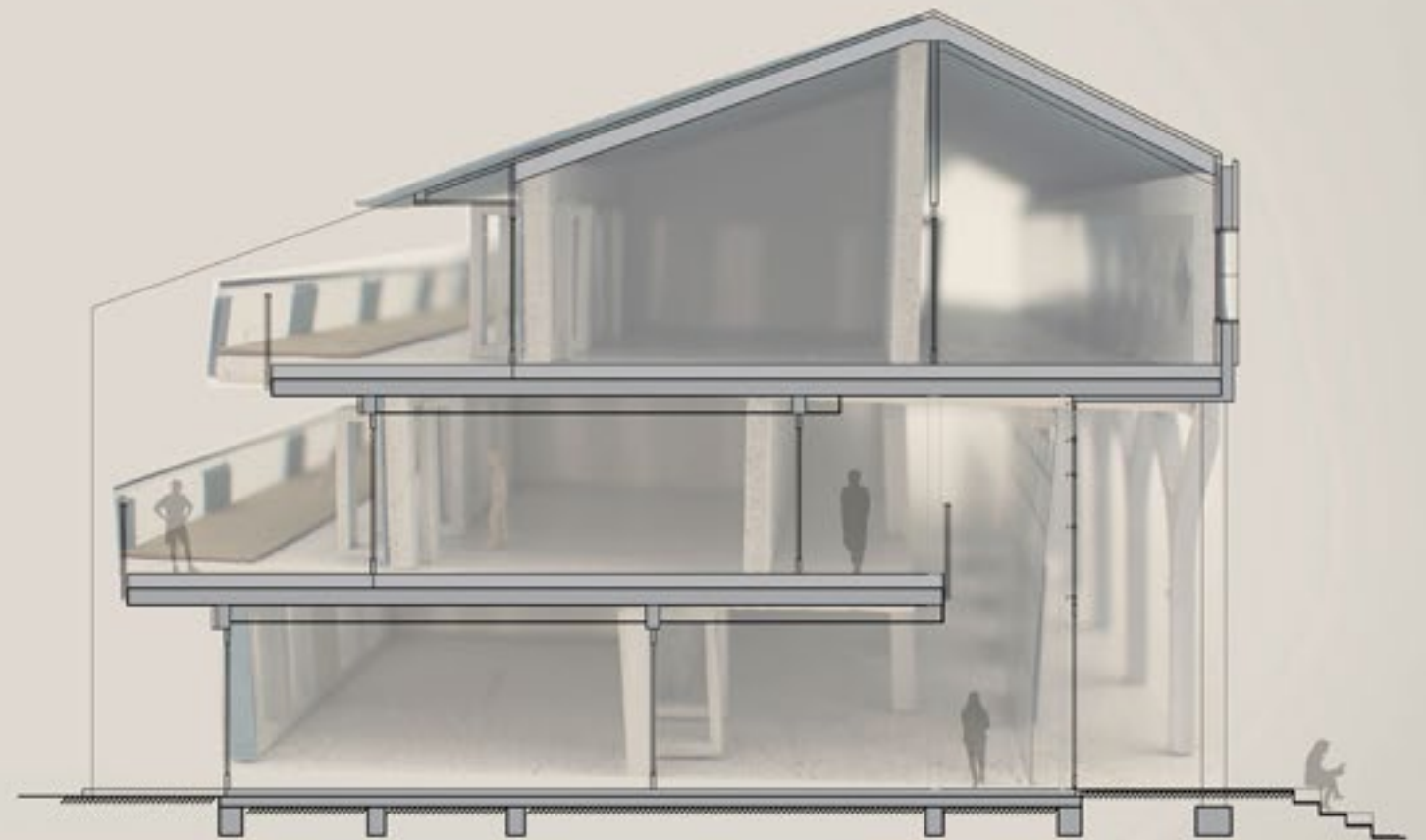

Inhoudelijk - Ontwikkeling van de doorsneden

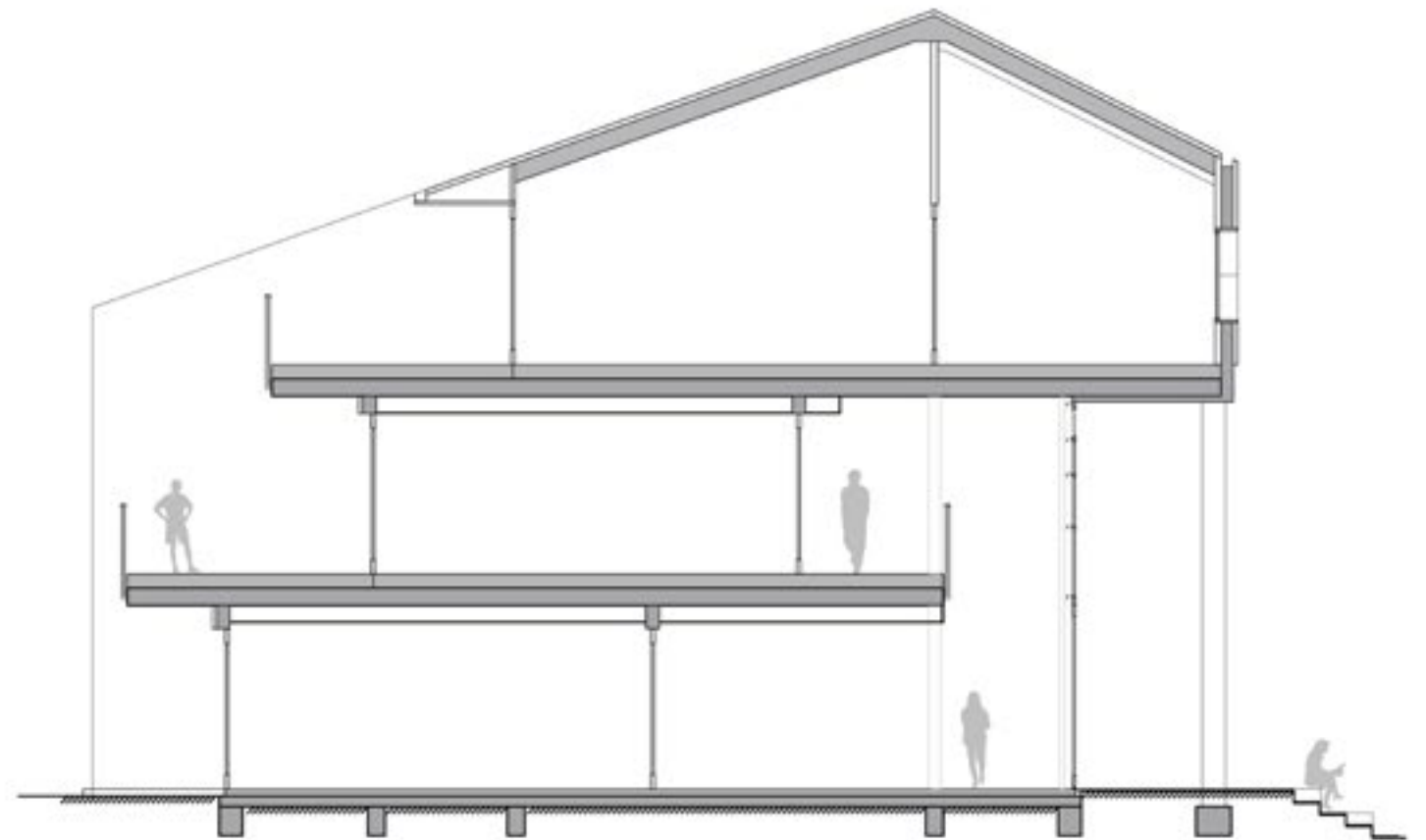

Beschrijving van het architectonisch ontwerp

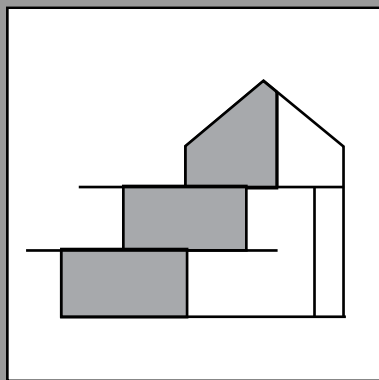

Onderdelen

Concept en kwaliteiten

Locatie

Gebouw

- beeld & compositie
- binnenplaats
- balkons
- dak
- gevel & materiaal
- constructie & stabiliteit

Los volume

- functie & gebruik

Studievleugels

- functie & gebruik
- lokalen
 - *beleving*
 - *klimaat*
- balkons
- gang

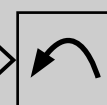
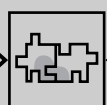
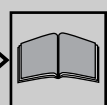

Concept en kwaliteiten

Montessori onderwijs

- individuele interesses
- leren in een sociale context
- school als afspiegeling van de 'echte' wereld (Hertzberger)

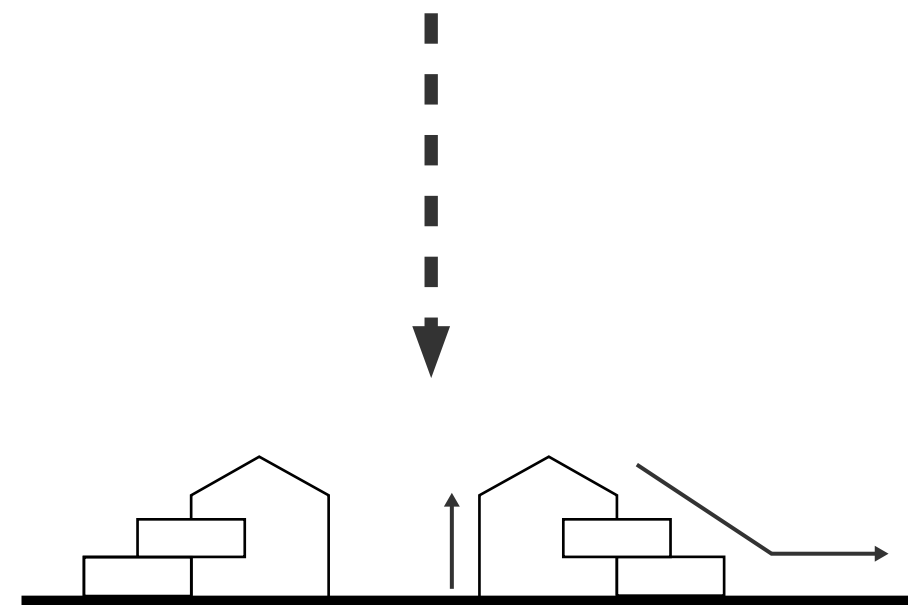

Micromaatschappij

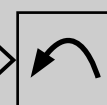
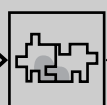
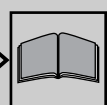

Concept en kwaliteiten

Montessori onderwijs

- individuele interesses
- leren in een sociale context
- school als afspiegeling van de 'echte' wereld (Hertzberger)

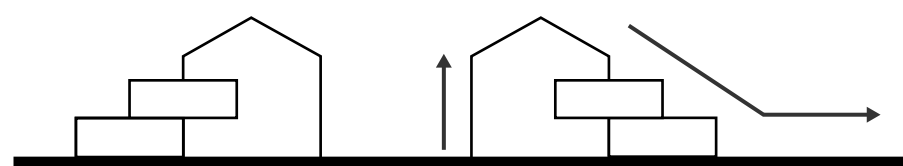

Micromaatschappij

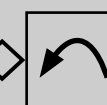
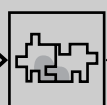
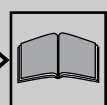
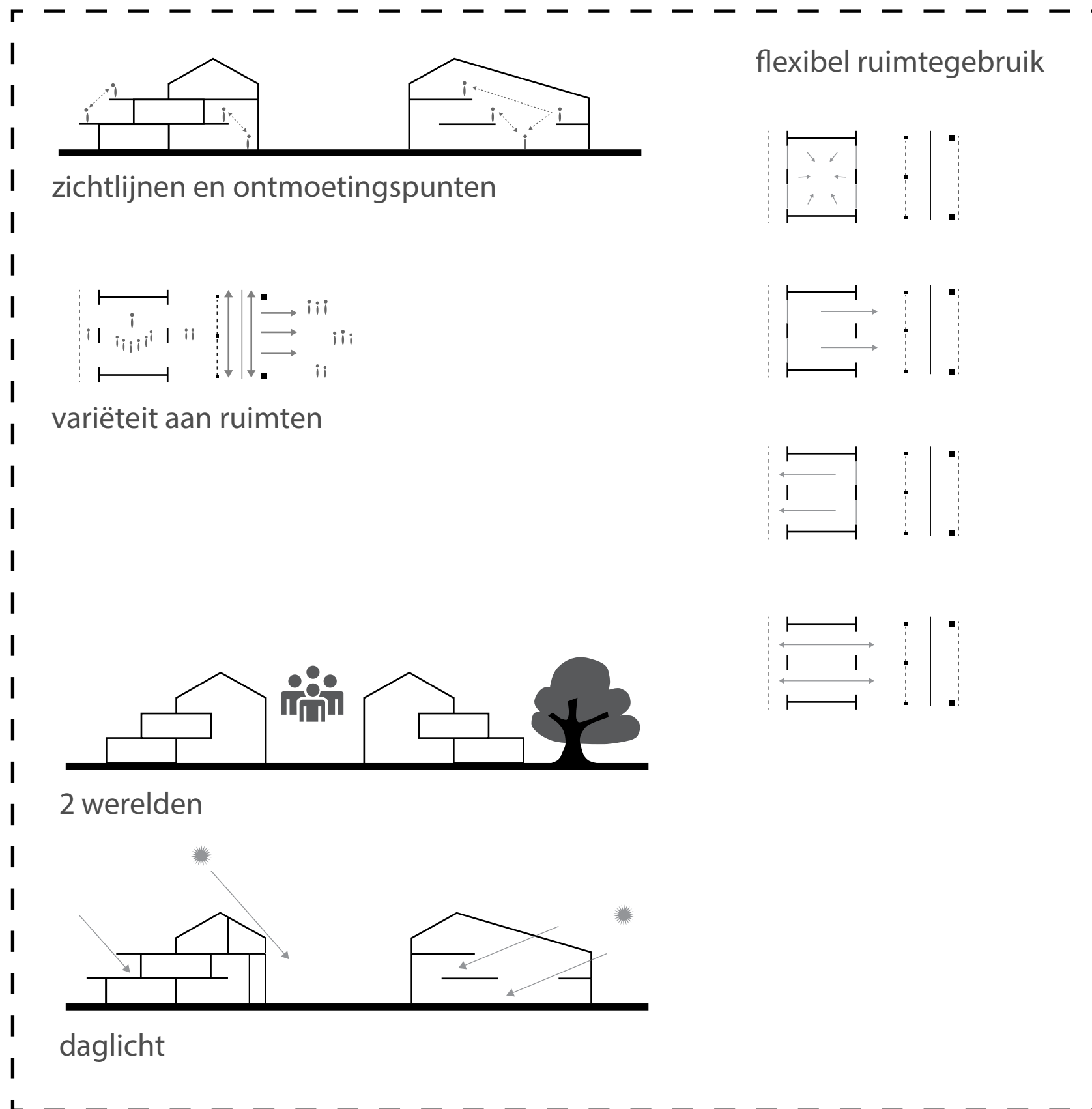

Ligging

Amersfoort - schothorst



Locatie



Westzijde: grens woonwijk en landelijke



Noordzijde: landelijk groen



Nabije omgeving: lage woningbouw



Zuidoostzijde: landelijk groen

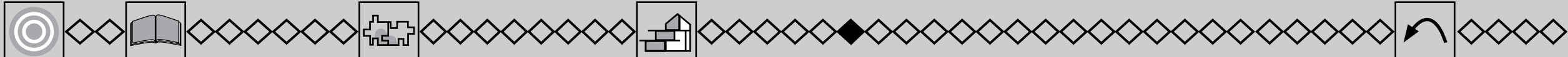

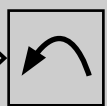
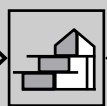
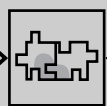
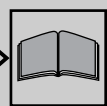

Gebouw

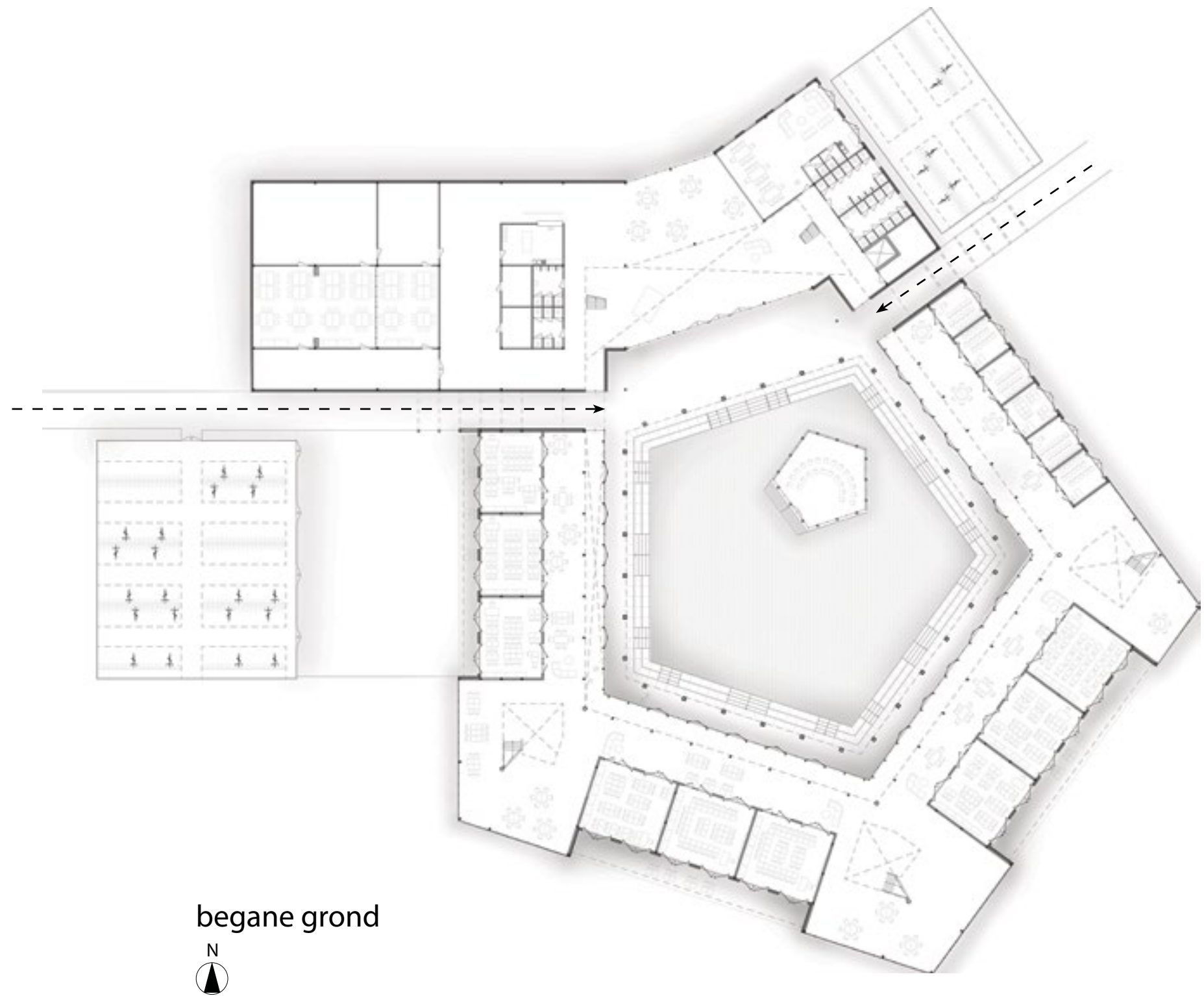
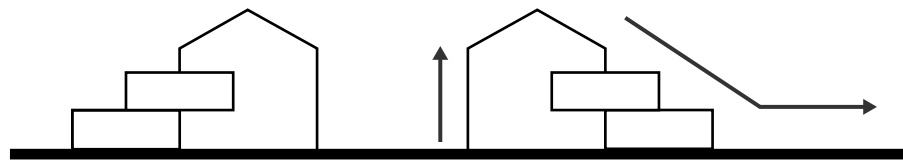

begane grond

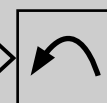
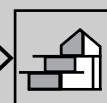
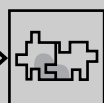
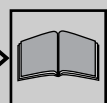

compositie

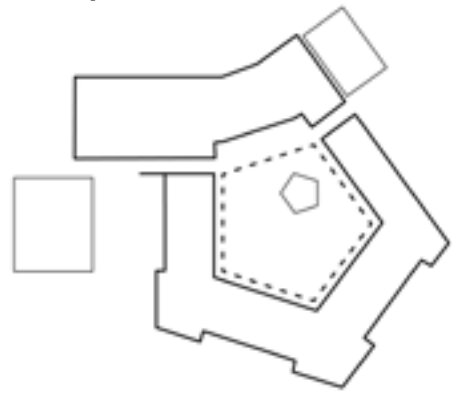

binnenplaats

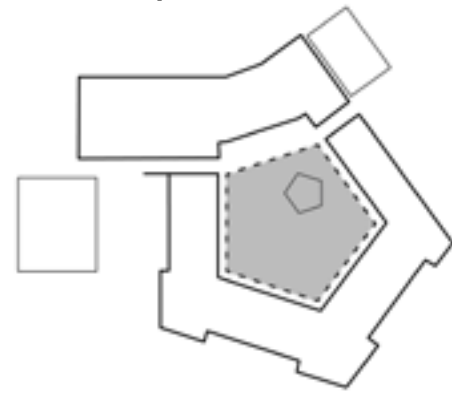

los volume

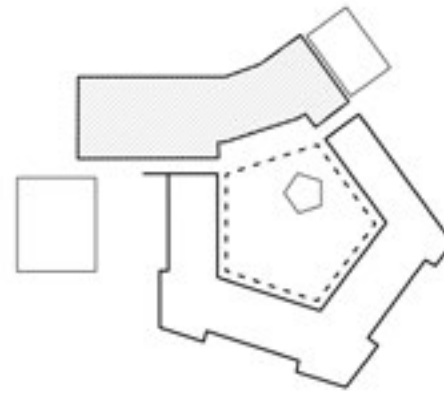

zijvleugels

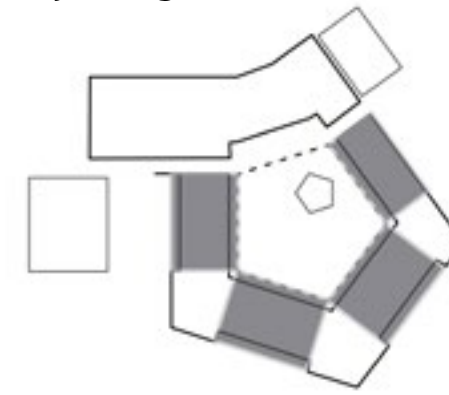

hoekpunten

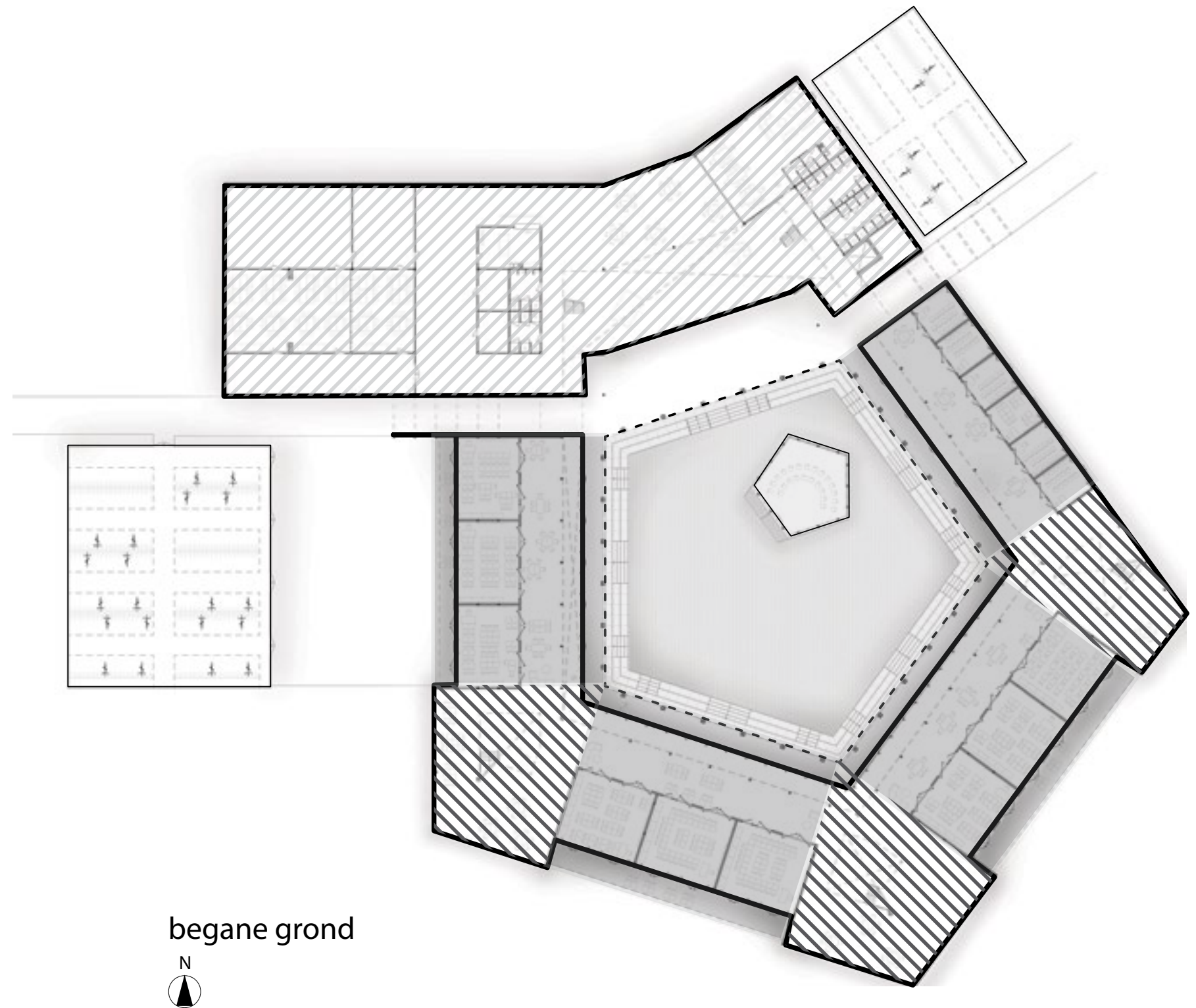
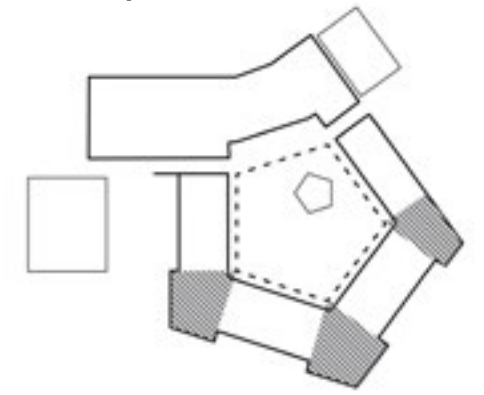

gebouw
compositie

begane grond

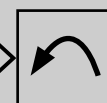
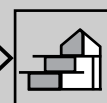
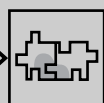
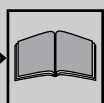

gebouw

Binnenplaats

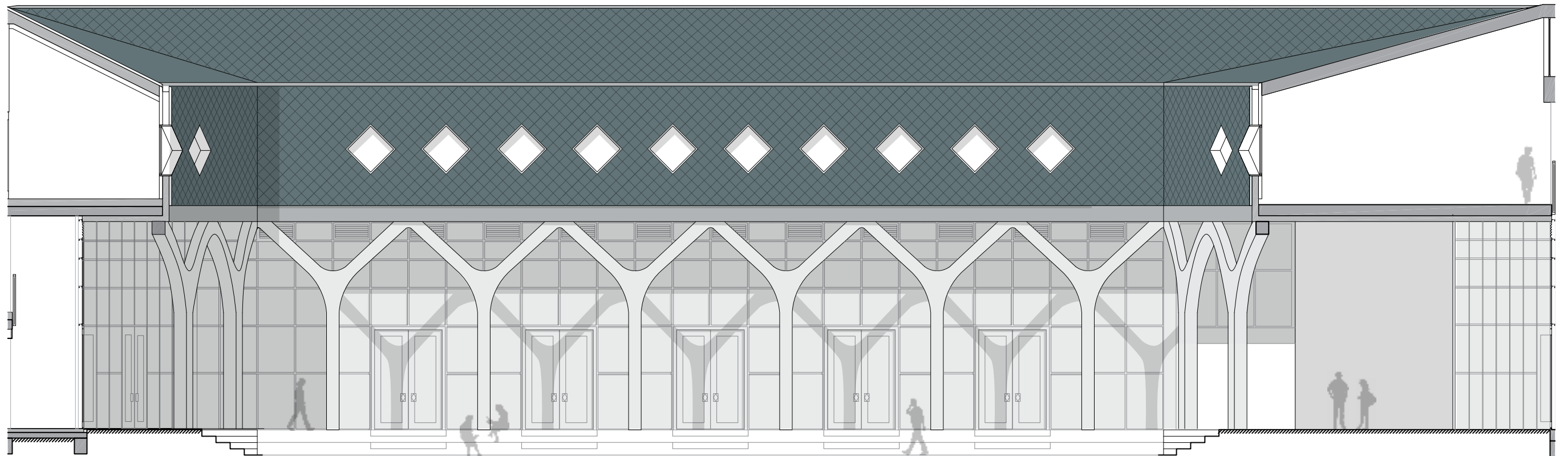
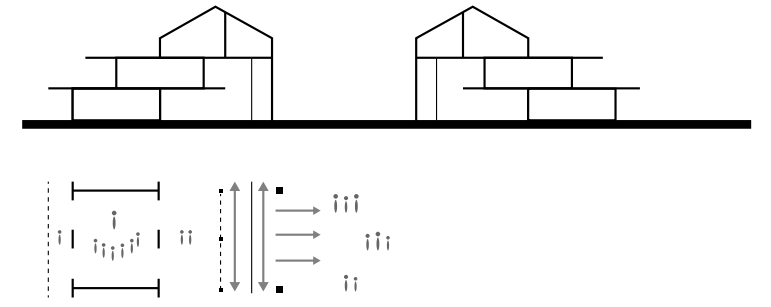
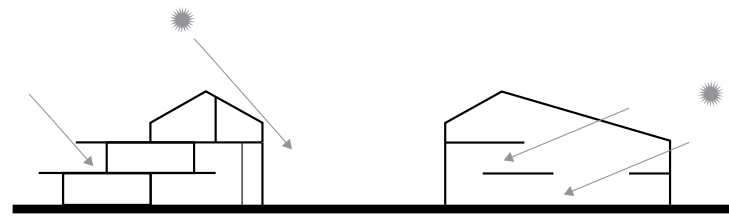
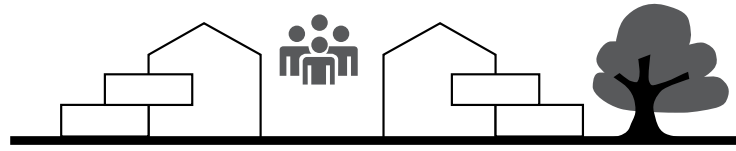

aanzicht binnenplaats

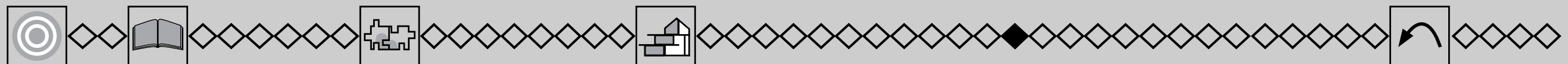

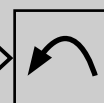
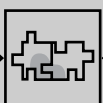
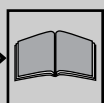

gebouw

Balkons

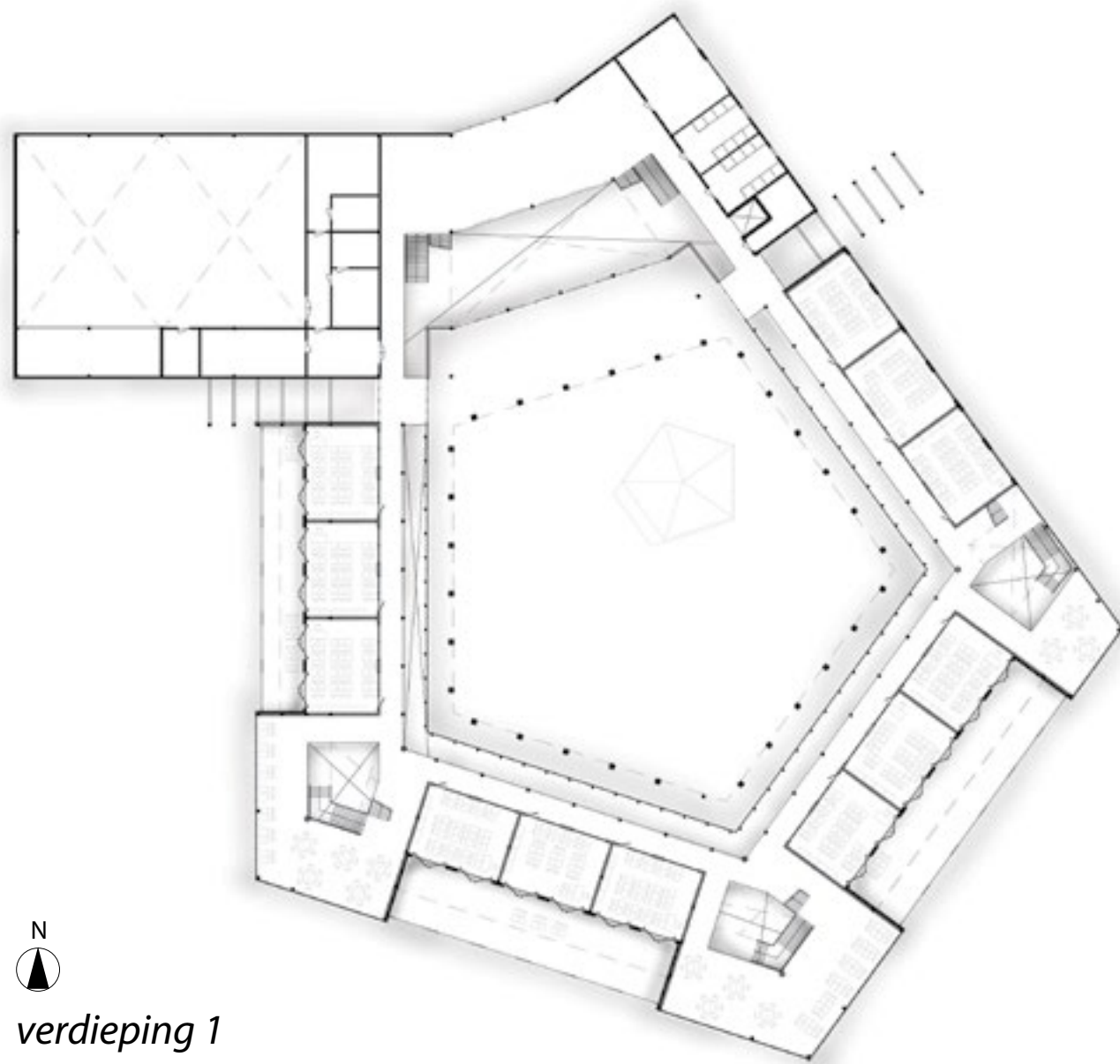
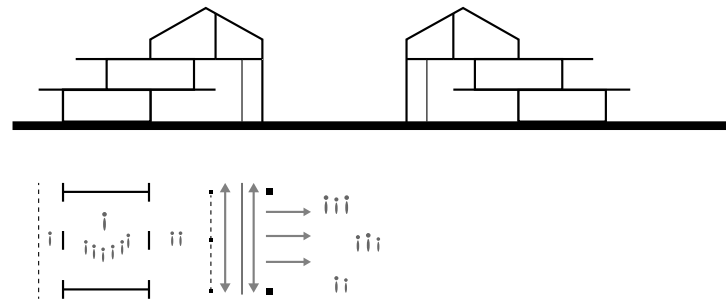
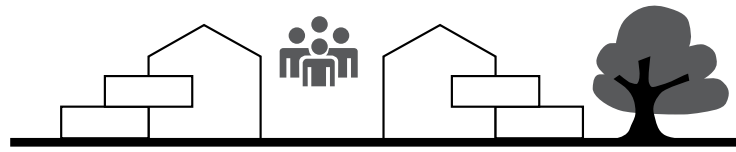

N
verdieping 1

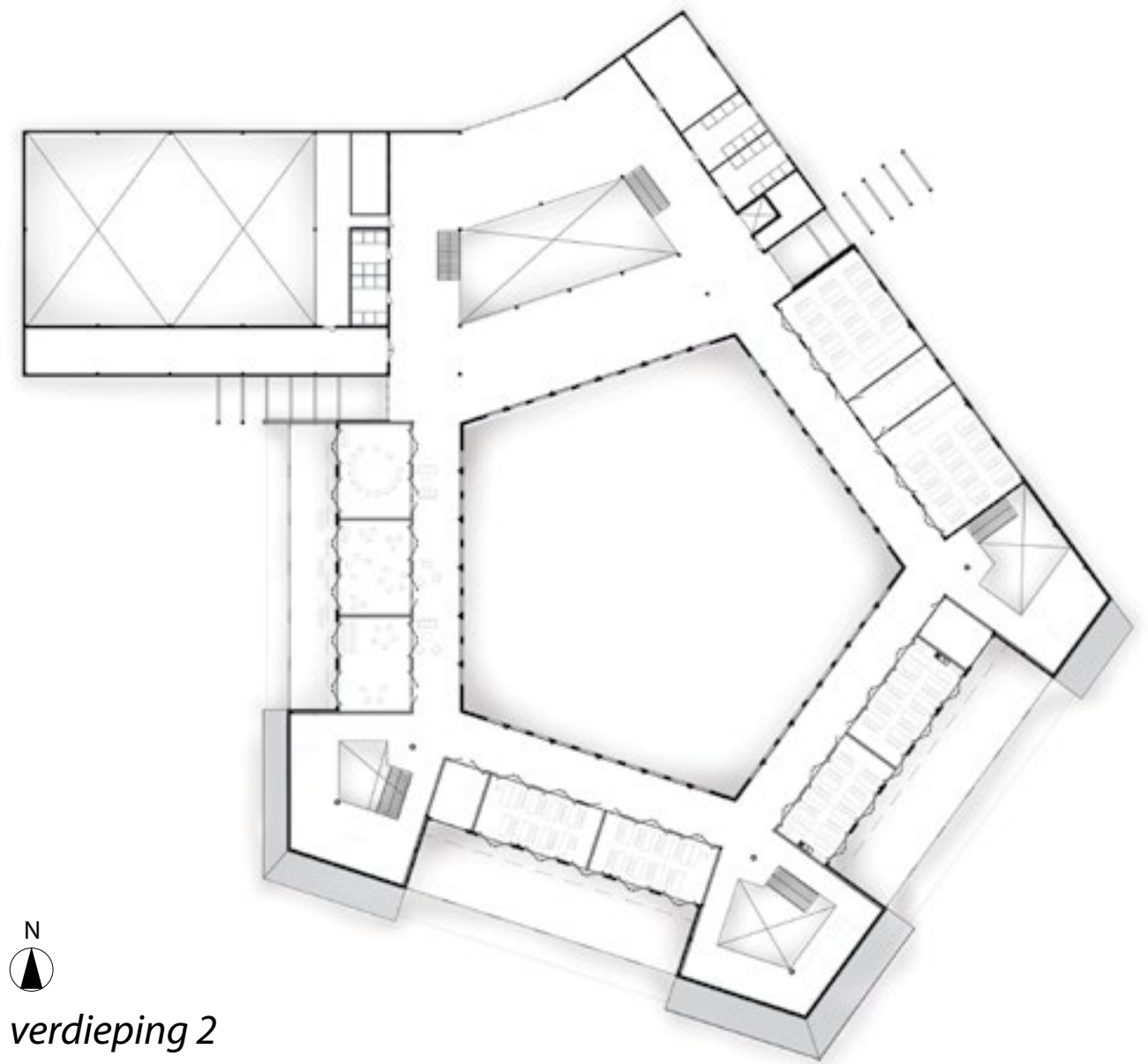

N
verdieping 2

gebouw
Balkons

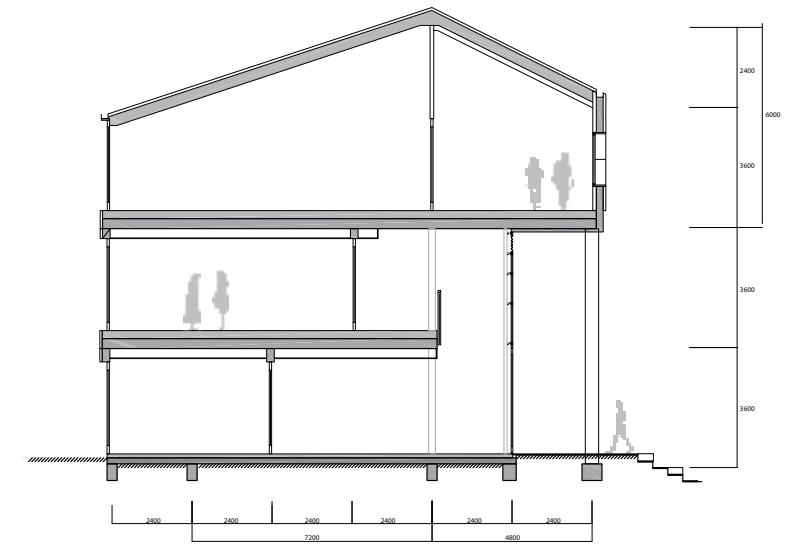
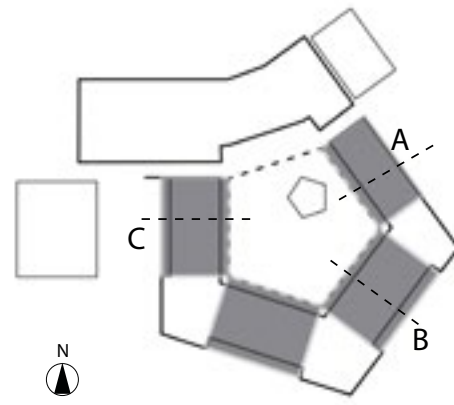
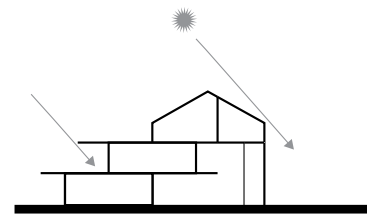

Doorsnede AA' noordoostzijde klaslokalen

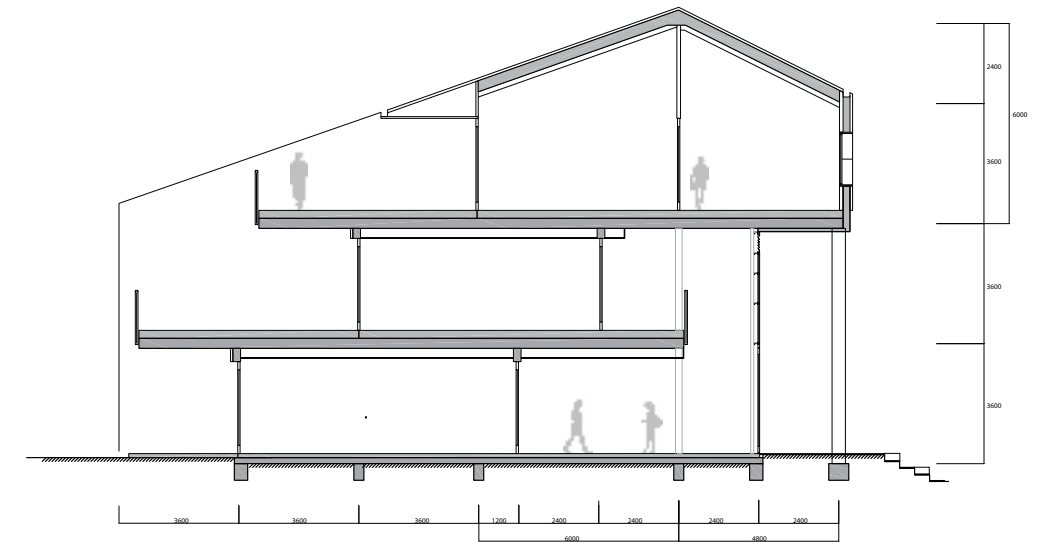

Doorsnede BB' zuidoostzijde klaslokalen

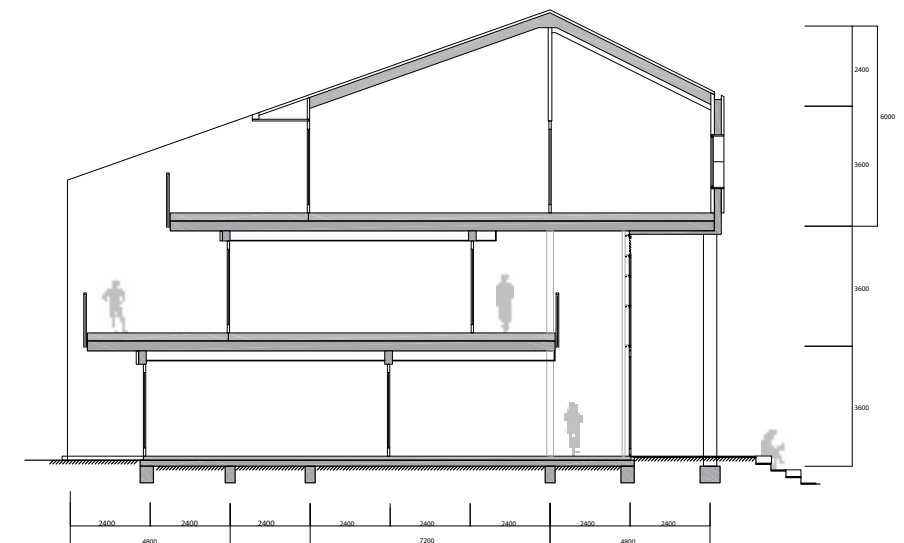

Doorsnede CC' westzijde klaslokalen



gebouw
Dak

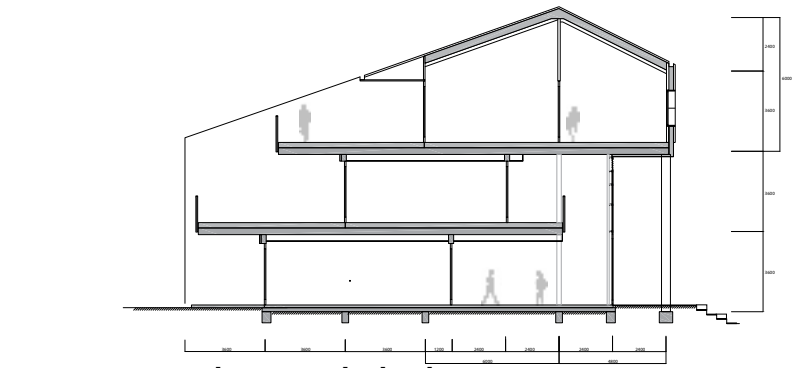
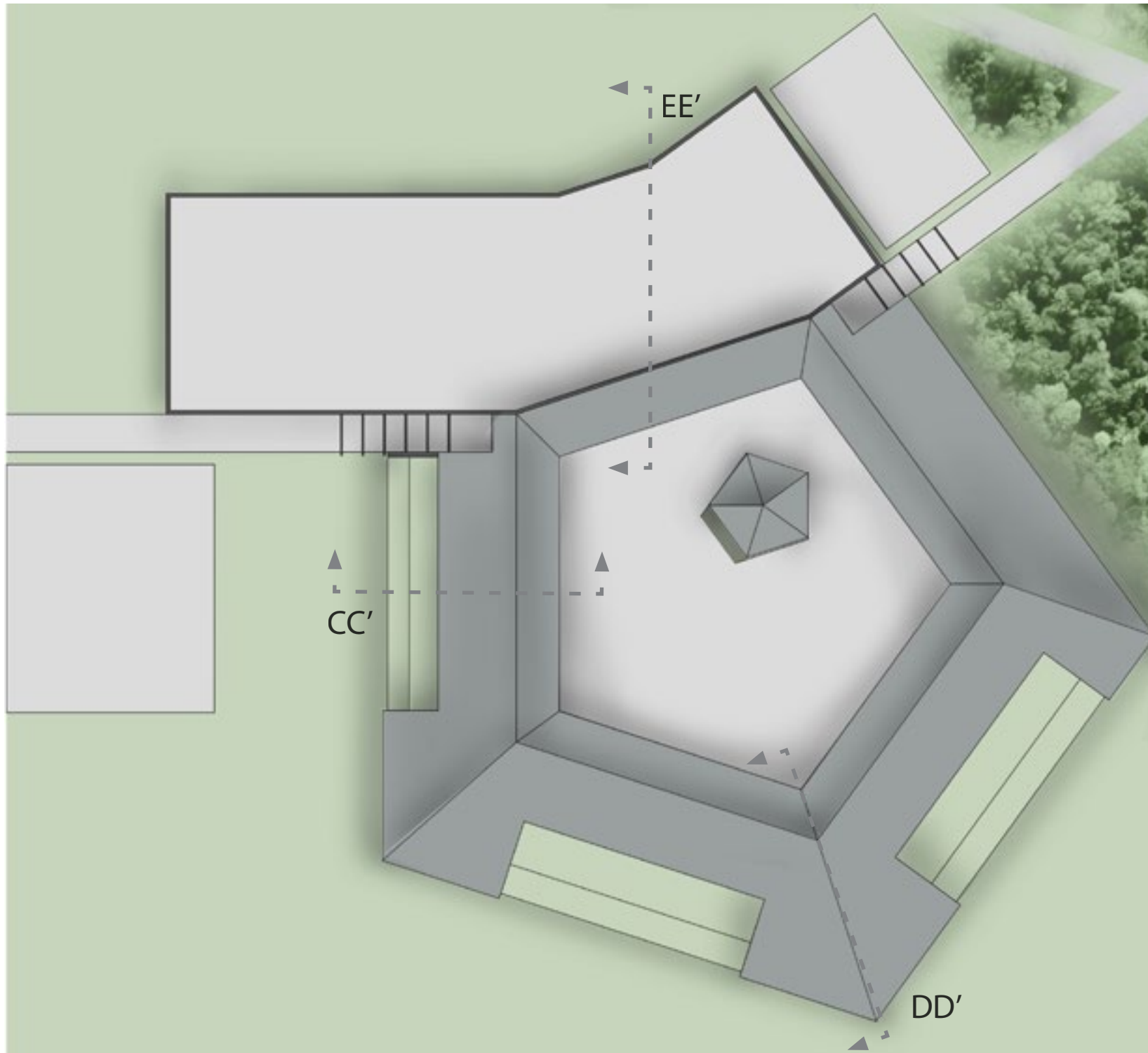
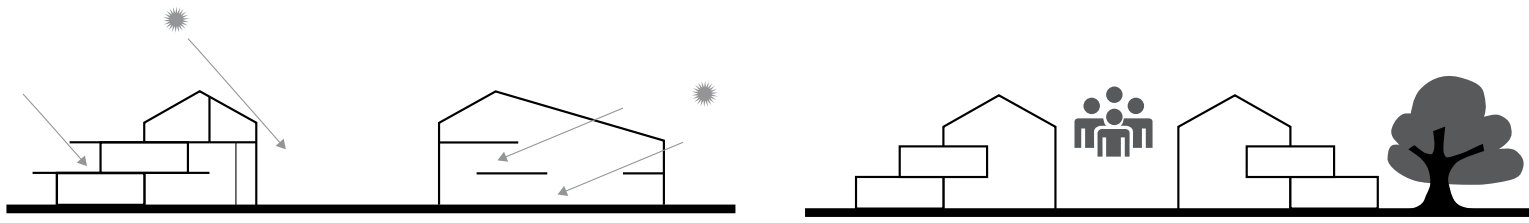

Doorsnede CC' lokalen

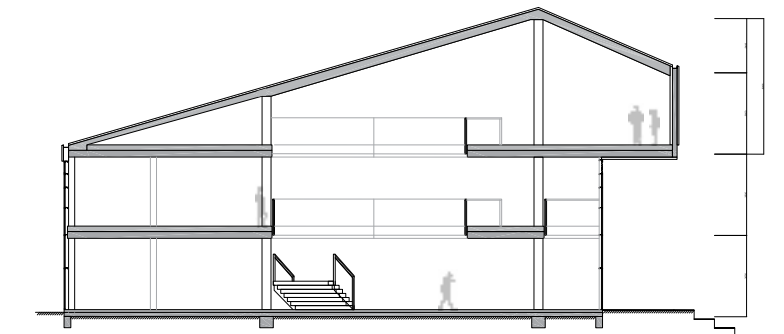

Doorsnede DD' hoekpunt

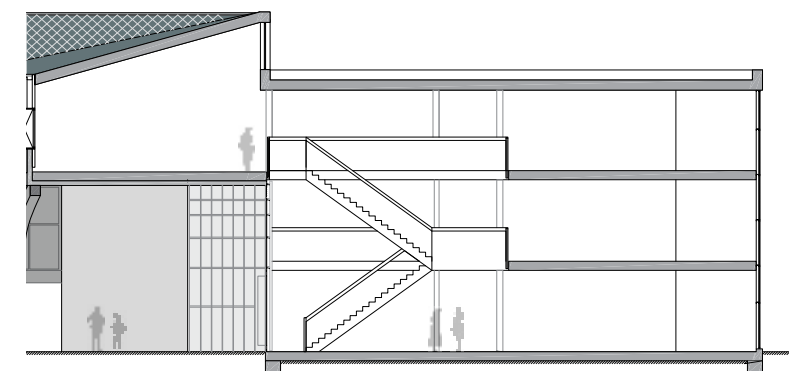

Doorsnede EE' centrale hal

gebouw
Dak



gebouw

gevel & materiaal

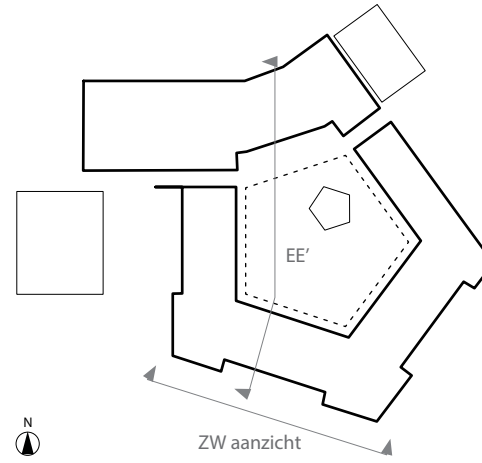
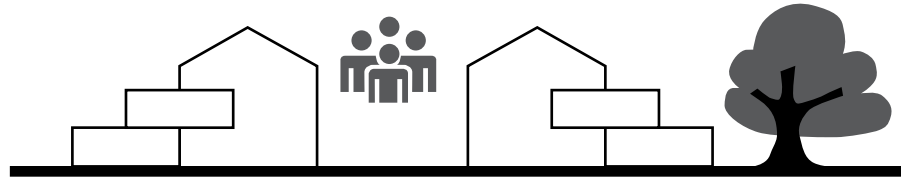

aanzicht zuidwest zijde

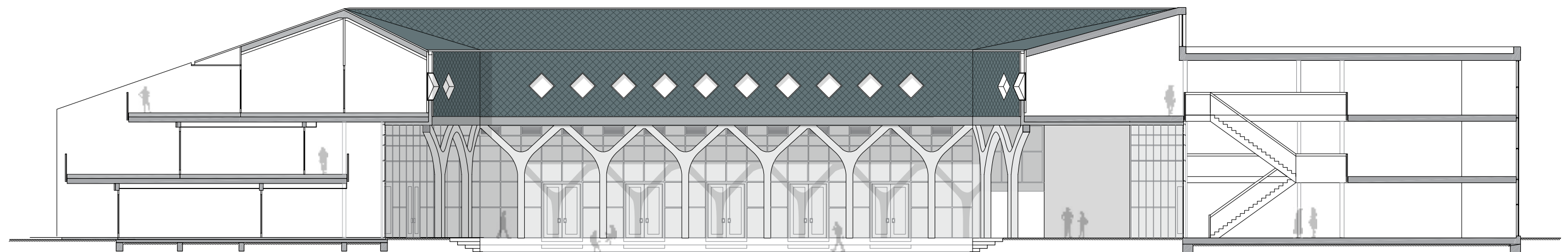

aanzicht binnenplaats

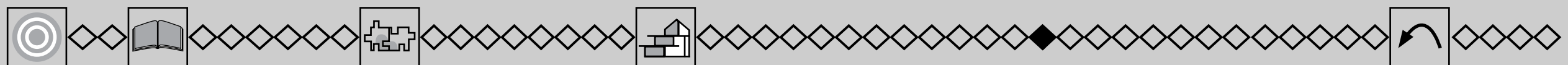

gebouw

gevel & materiaal

Buitenzijde: verschil tussen de zijvleugels en hoekpunten

1. zijvleugels

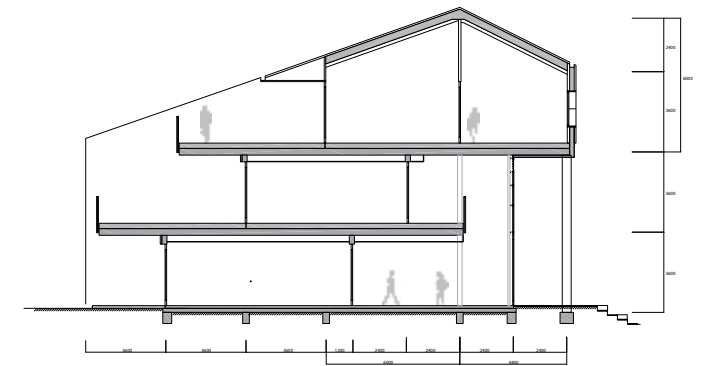
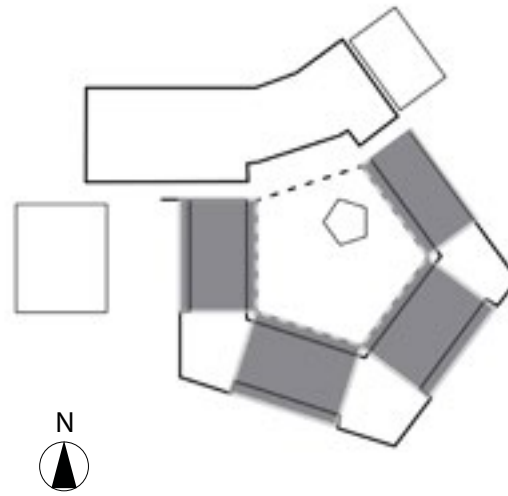

Doorsnede CC' lokalen

2. hoekpunten

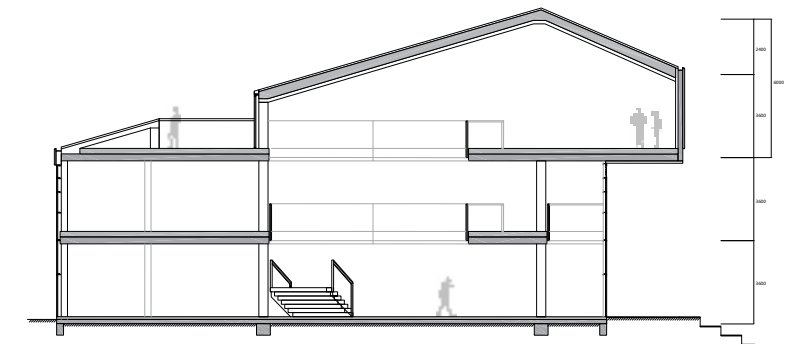
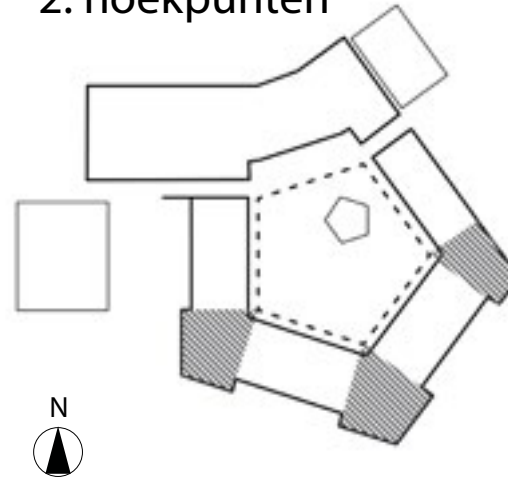

Doorsnede DD' hoekpunt

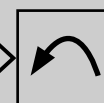
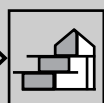
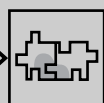
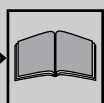

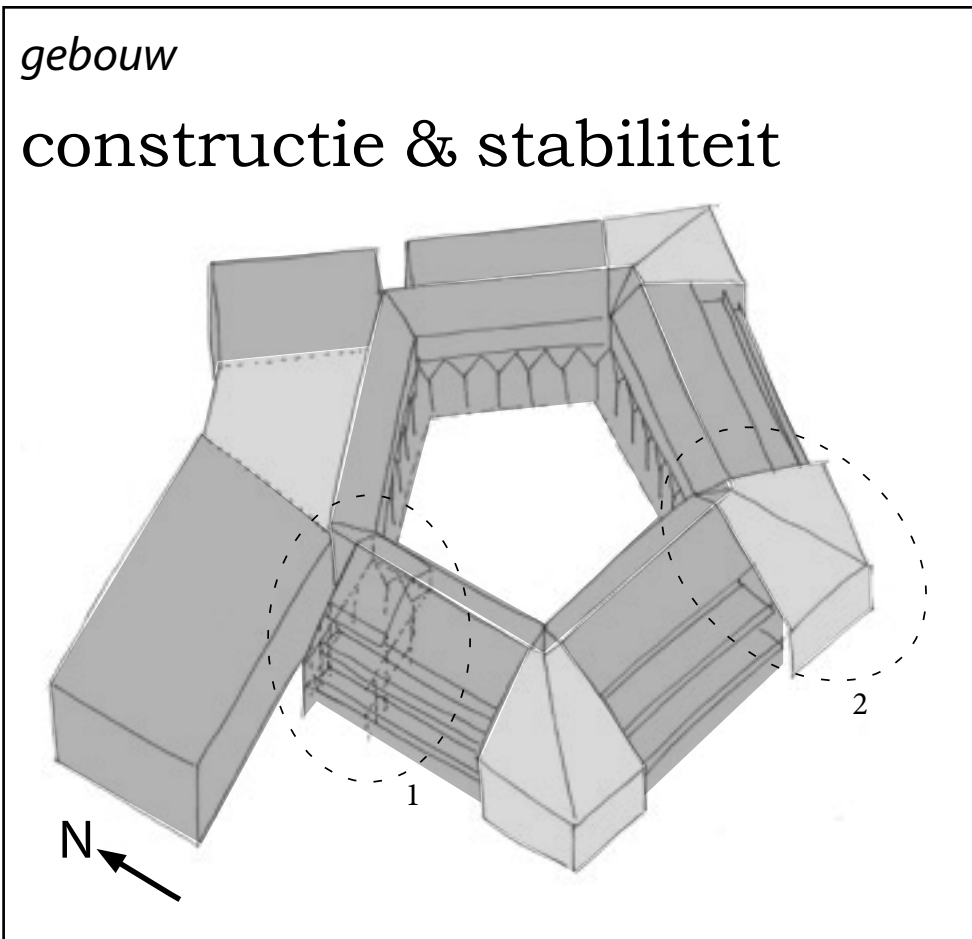

1. zijvleugels

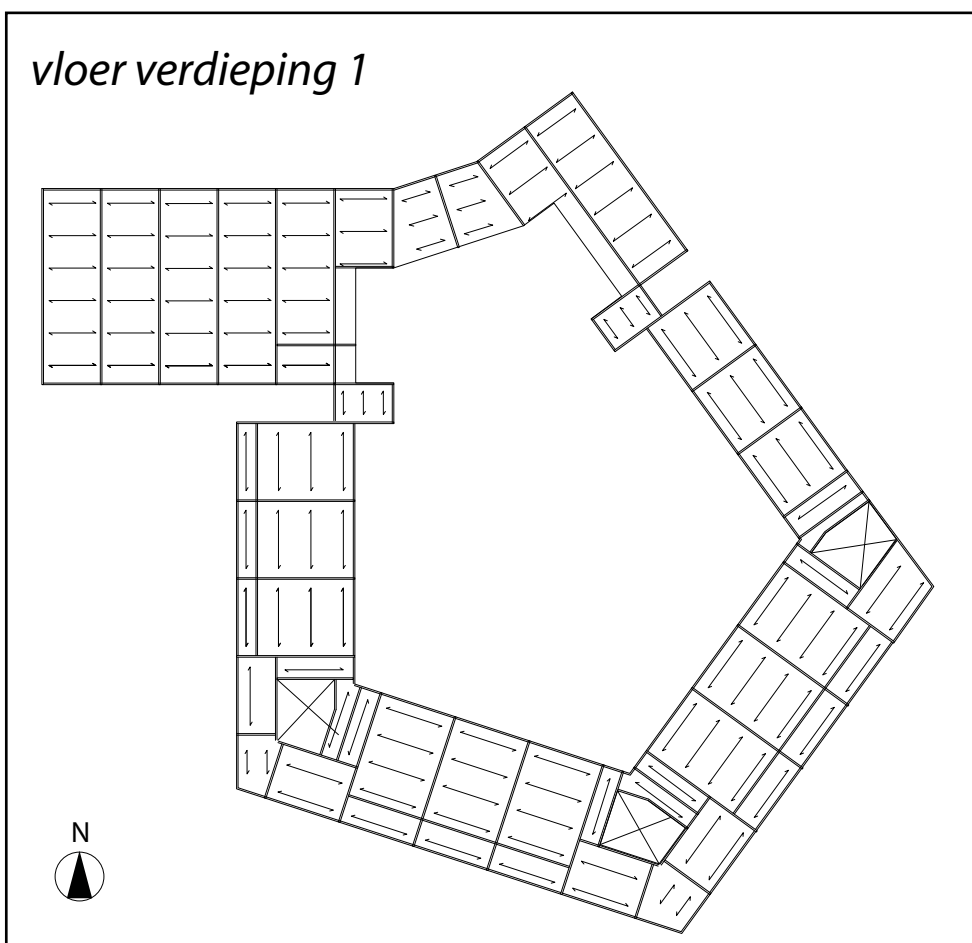
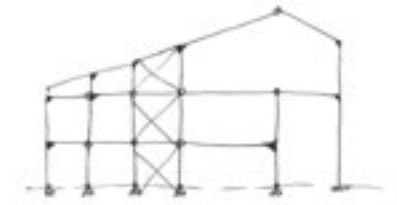
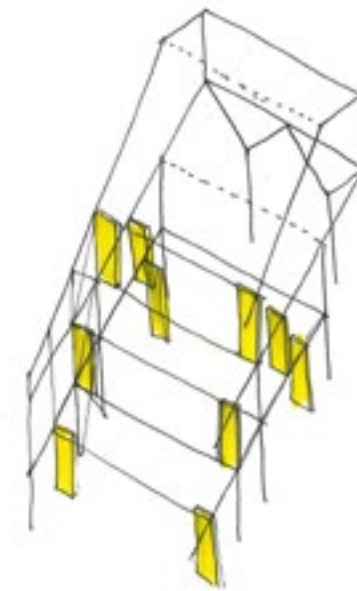
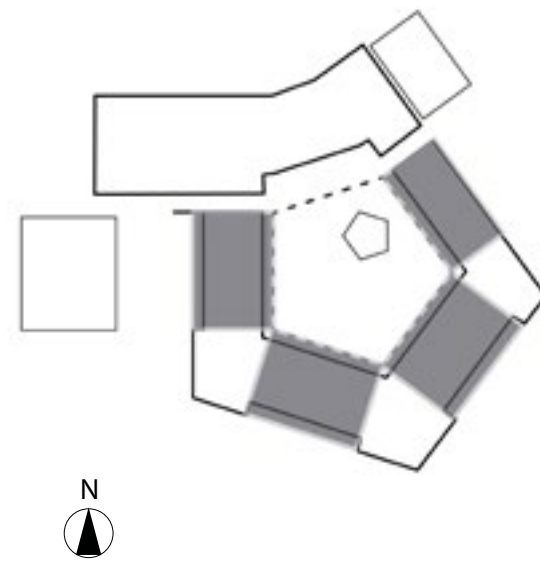

2. hoekpunten

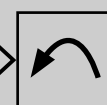
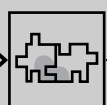
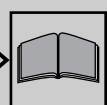
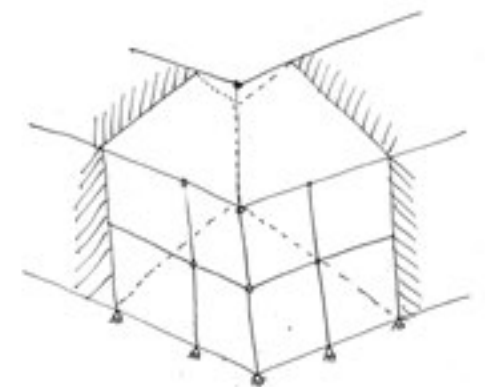
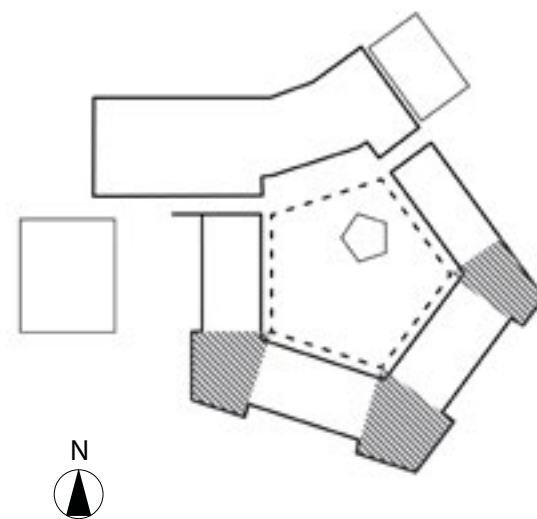

gebouw

constructie & materiaal

- Alterna ruitlei van Eternit
- Dambordpatroon
- Vezelcementplaat

fragment buiten



fragment binnenplaats

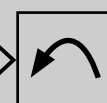
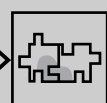
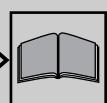
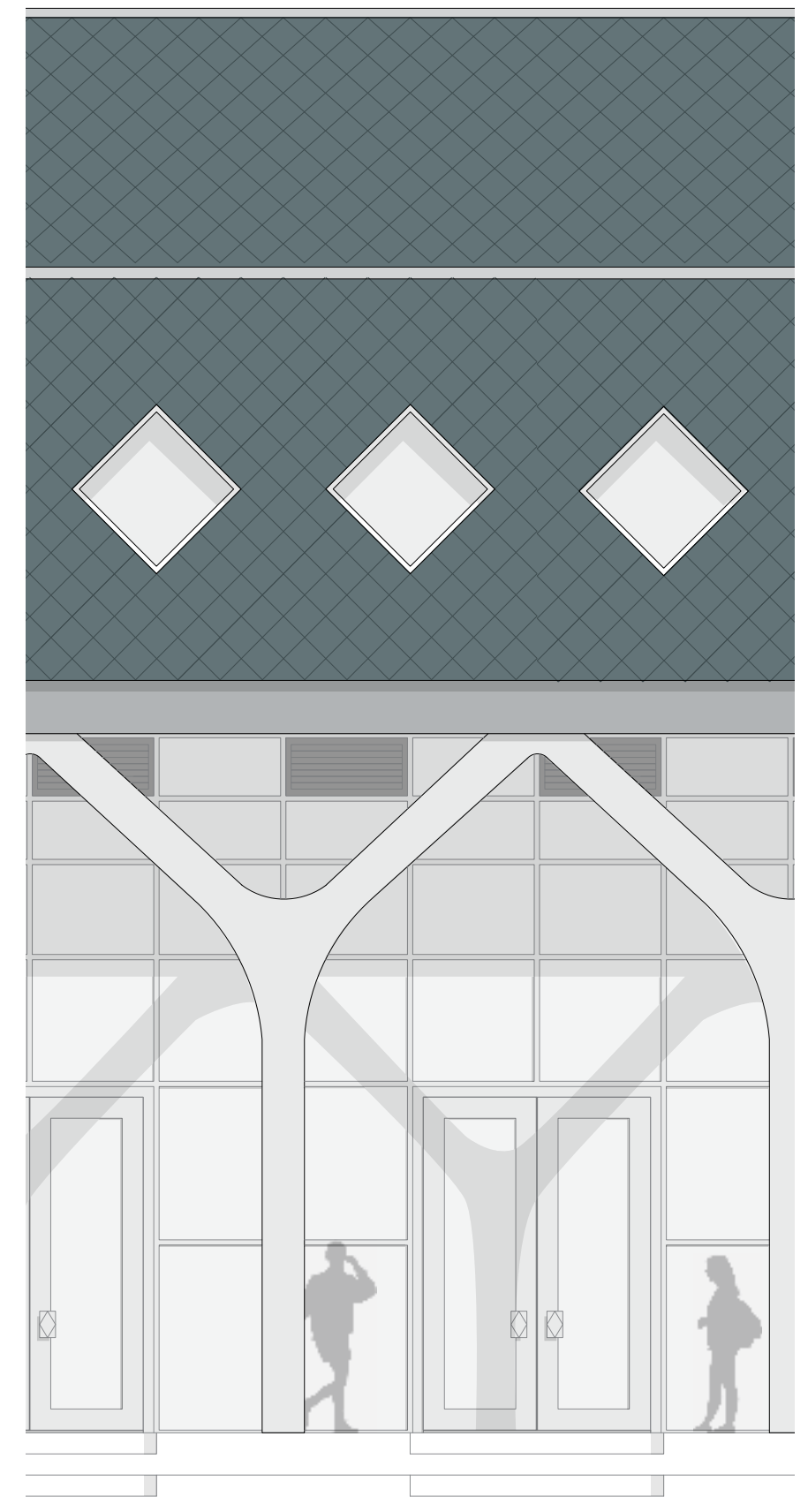

gebouw
constructie & materiaal

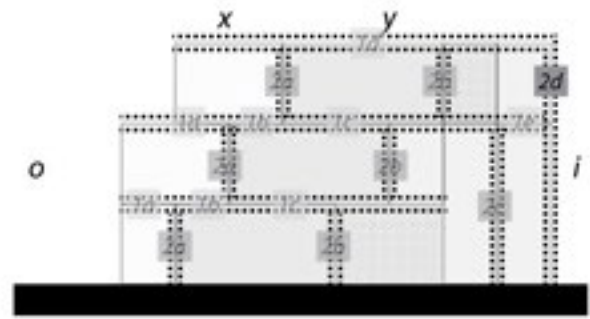

2d: wand: binnen - buiten (binnenplaats)

- Afwerking**
 - Leistenen
 - Substructuur**
 - Stijlen - regels
 - Houten frame
 - Isolatie
 - Draagstructuur**
 - stalen spanten (HEA 200)
- Openingen**
ramen

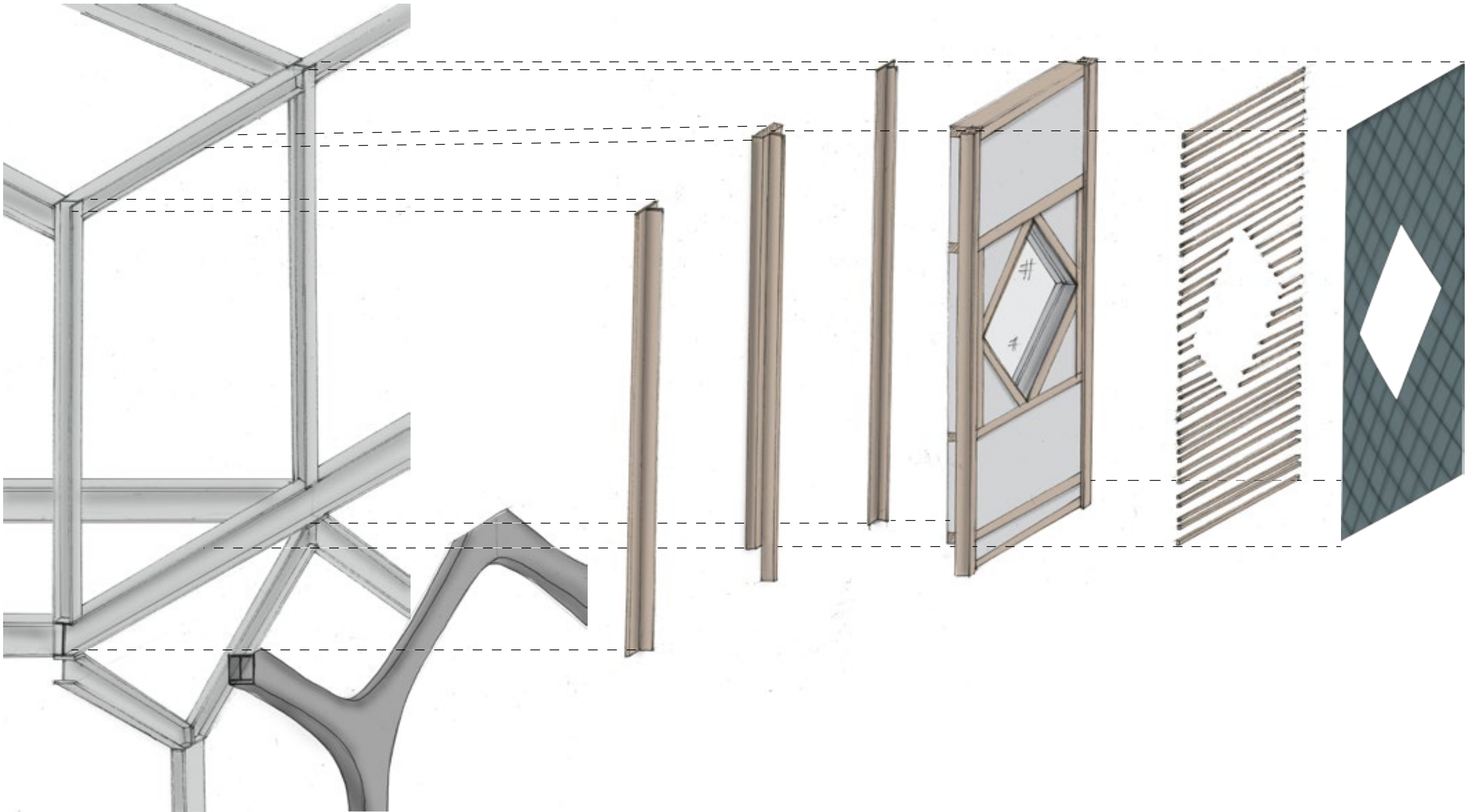

gebouw
gevel & materiaal

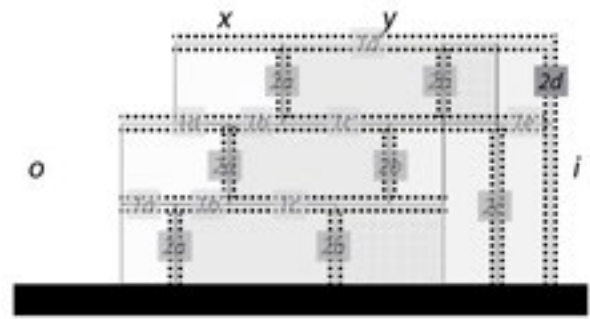

2d: wand: binnen - buiten (binnenplaats)

- | | |
|---|---------------------------|
| Afwerking
Leistenen | Openingen
ramen |
| Substructuur
Stijlen - regels
Houten frame
Isolatie | |
| Draagstructuur
stalen spanten (HEA 200) | |

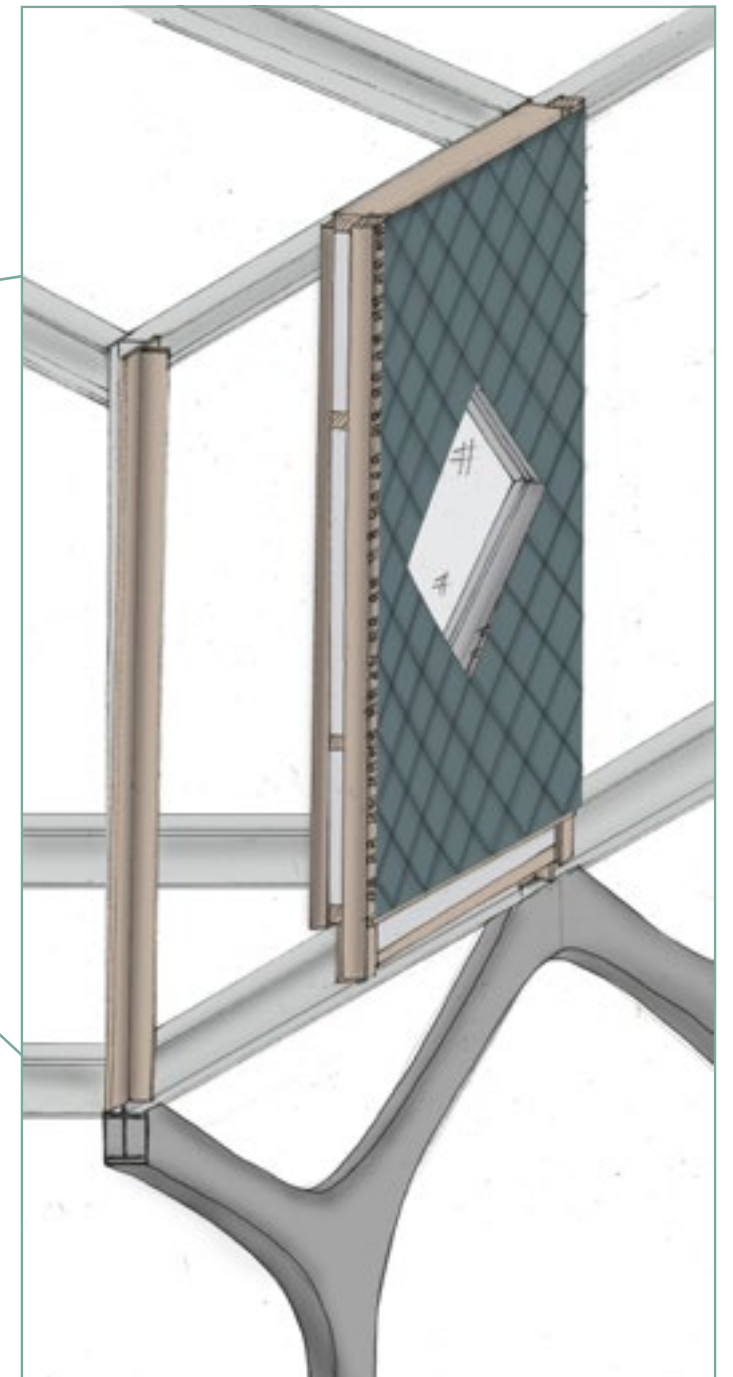
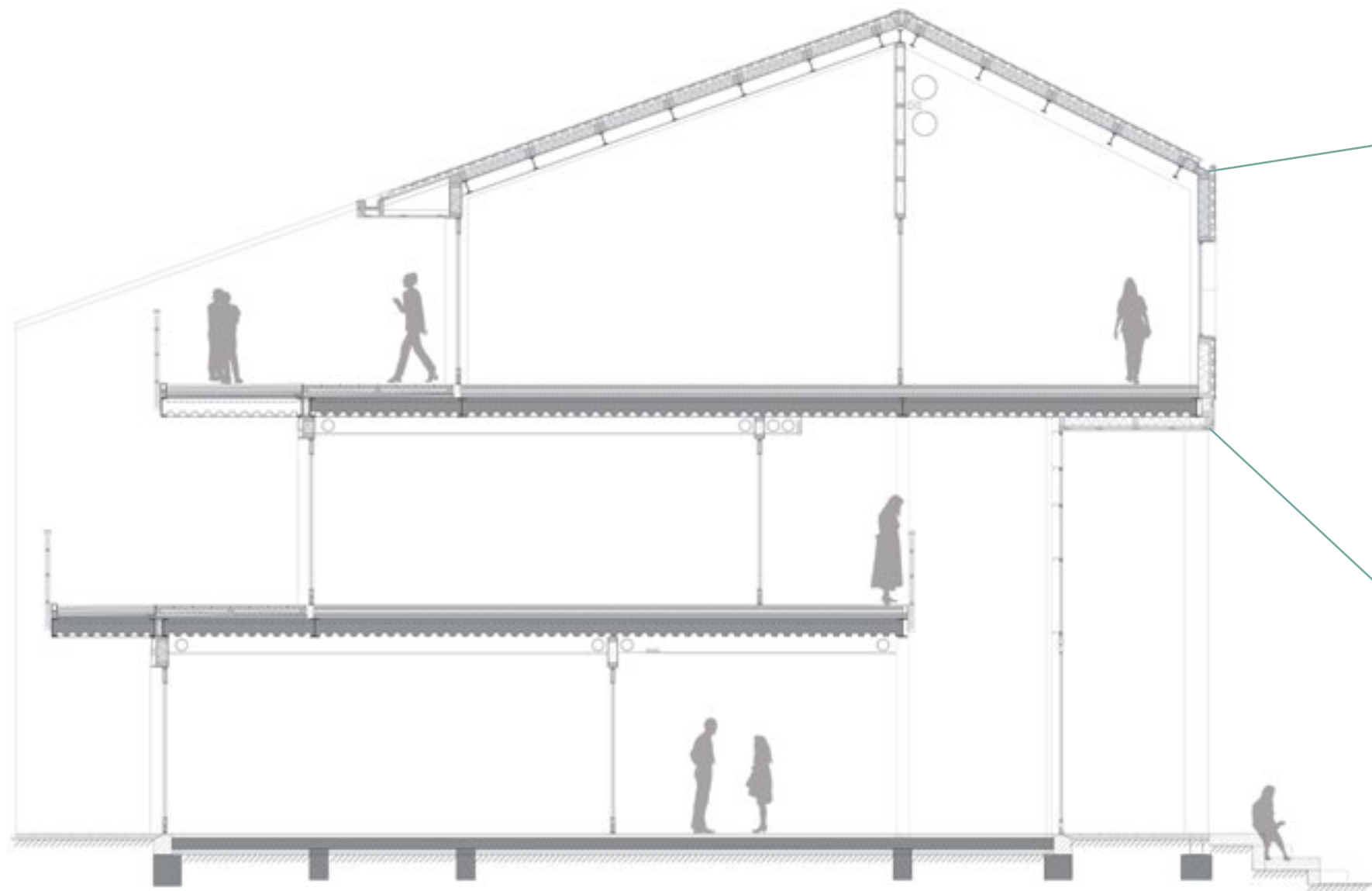

los volume

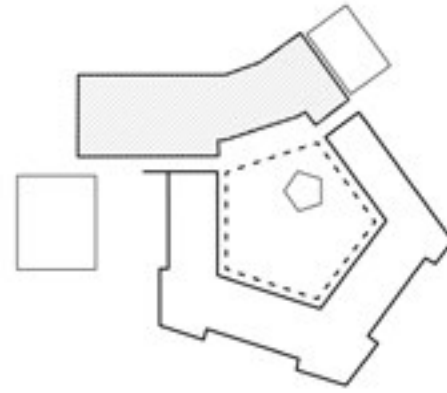

zijvleugels

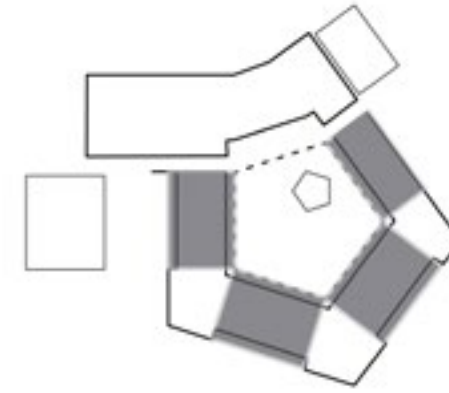

hoekpunten

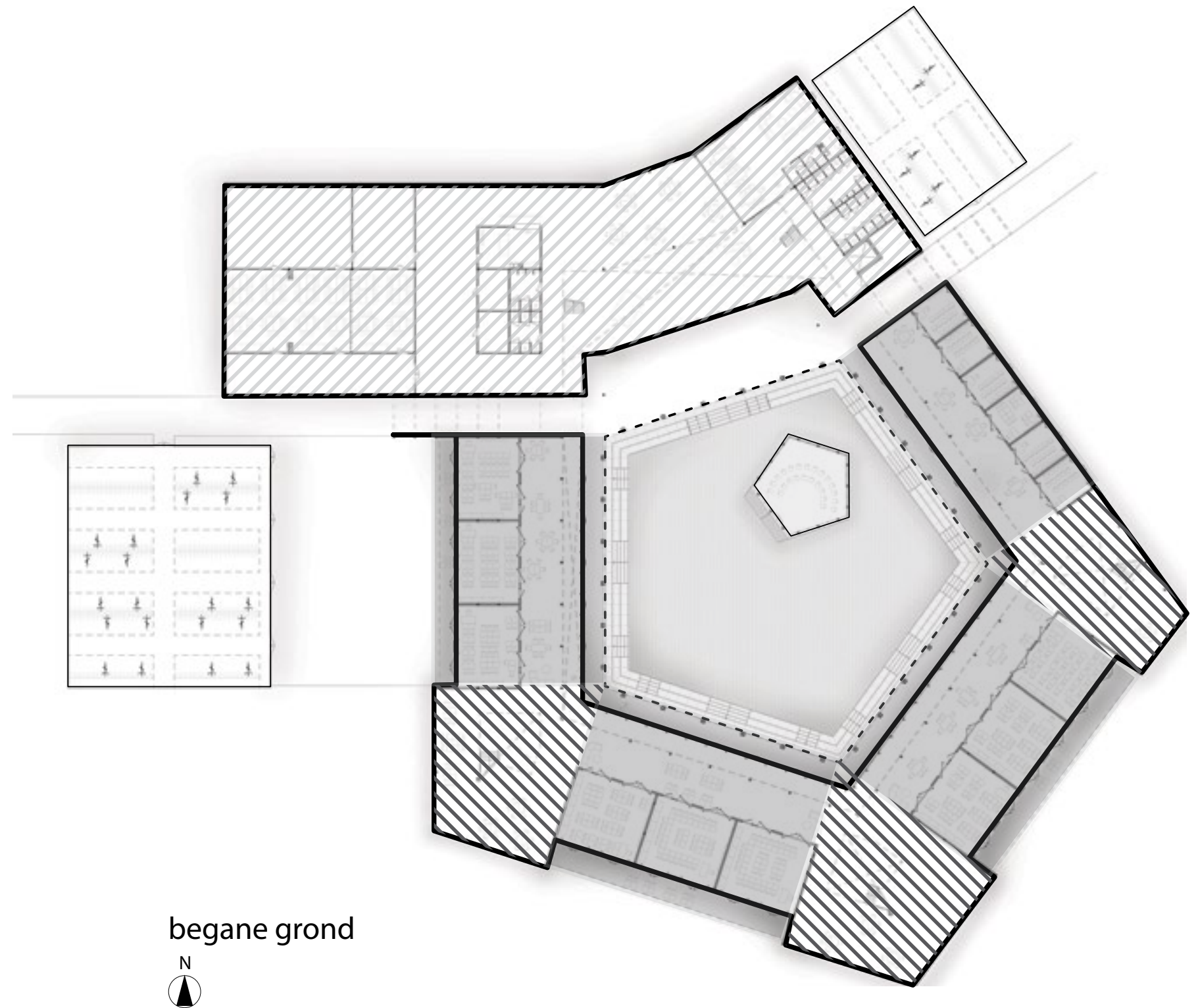
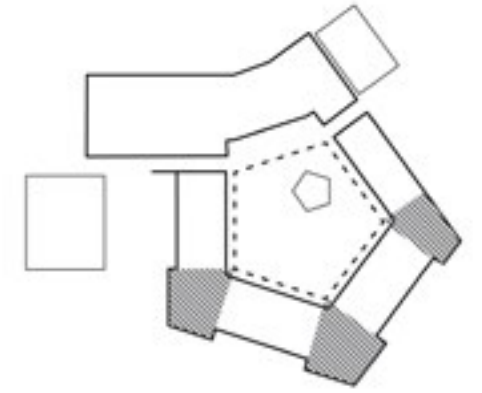

gebouw
compositie

begane grond

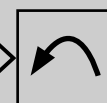
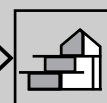
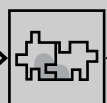
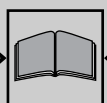

los volume
functie & gebruik

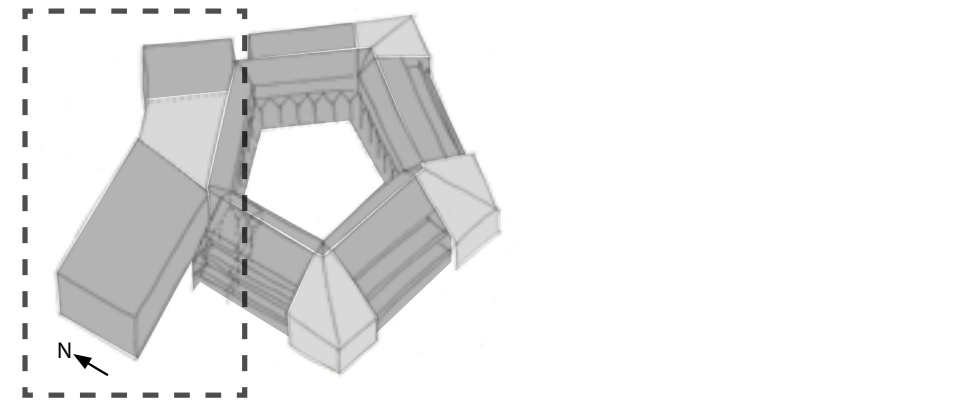

Verdieping 2

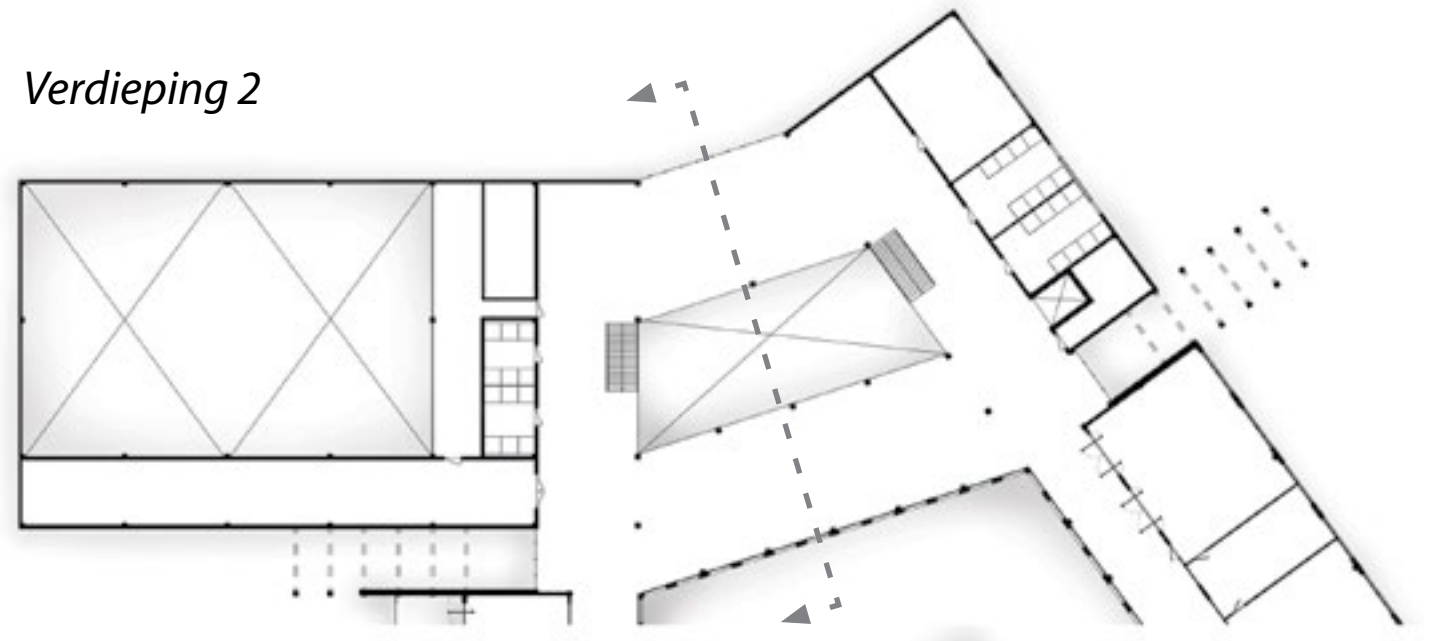

Verdieping 1

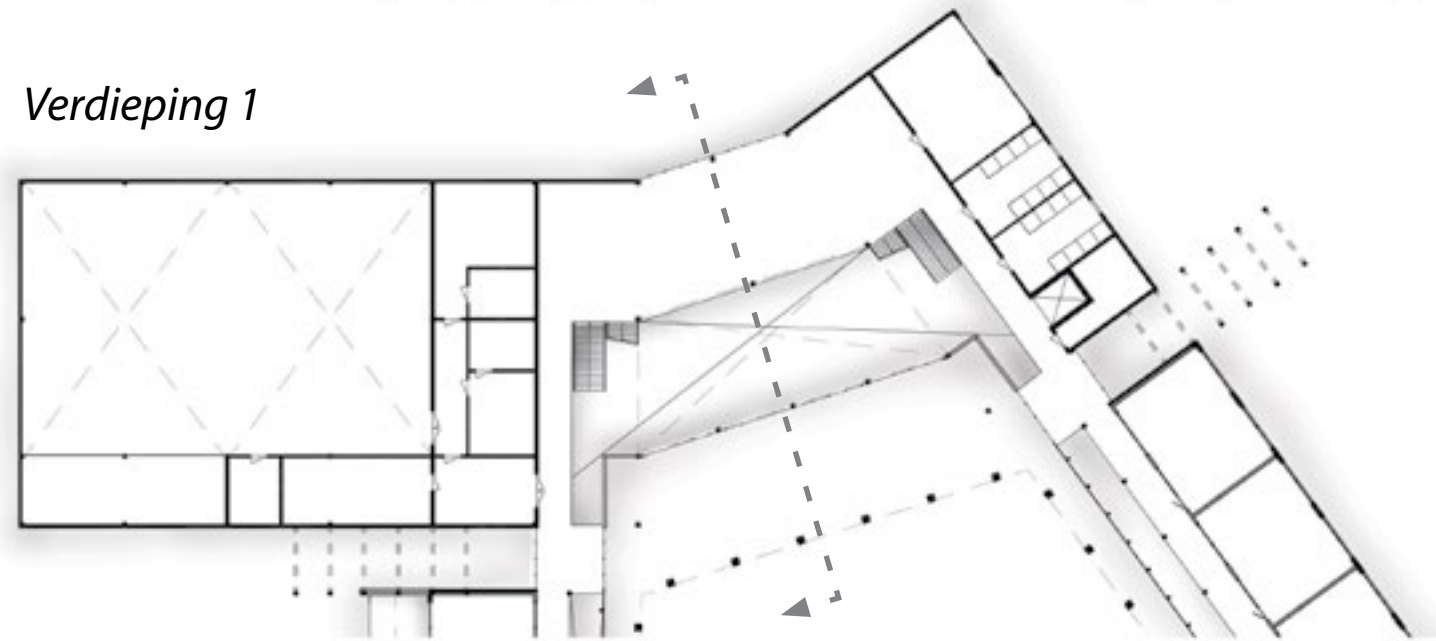

Begane grond

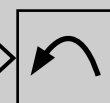
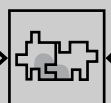
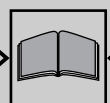
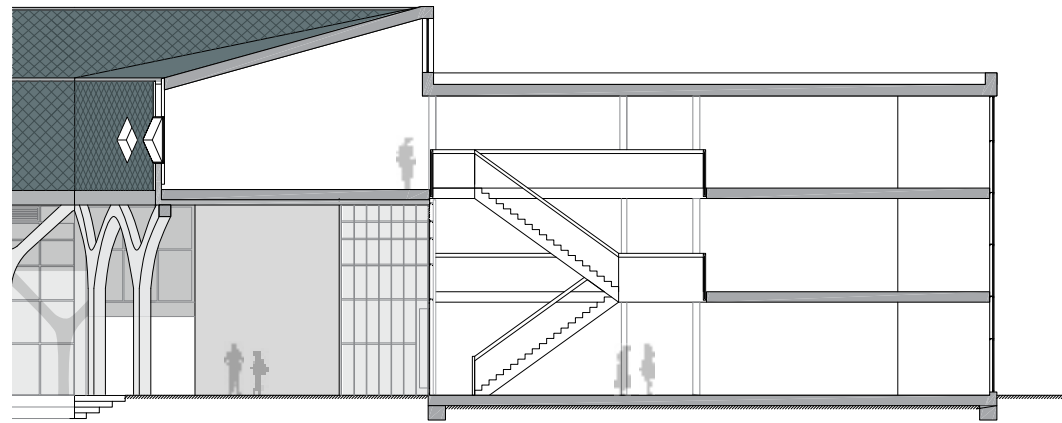
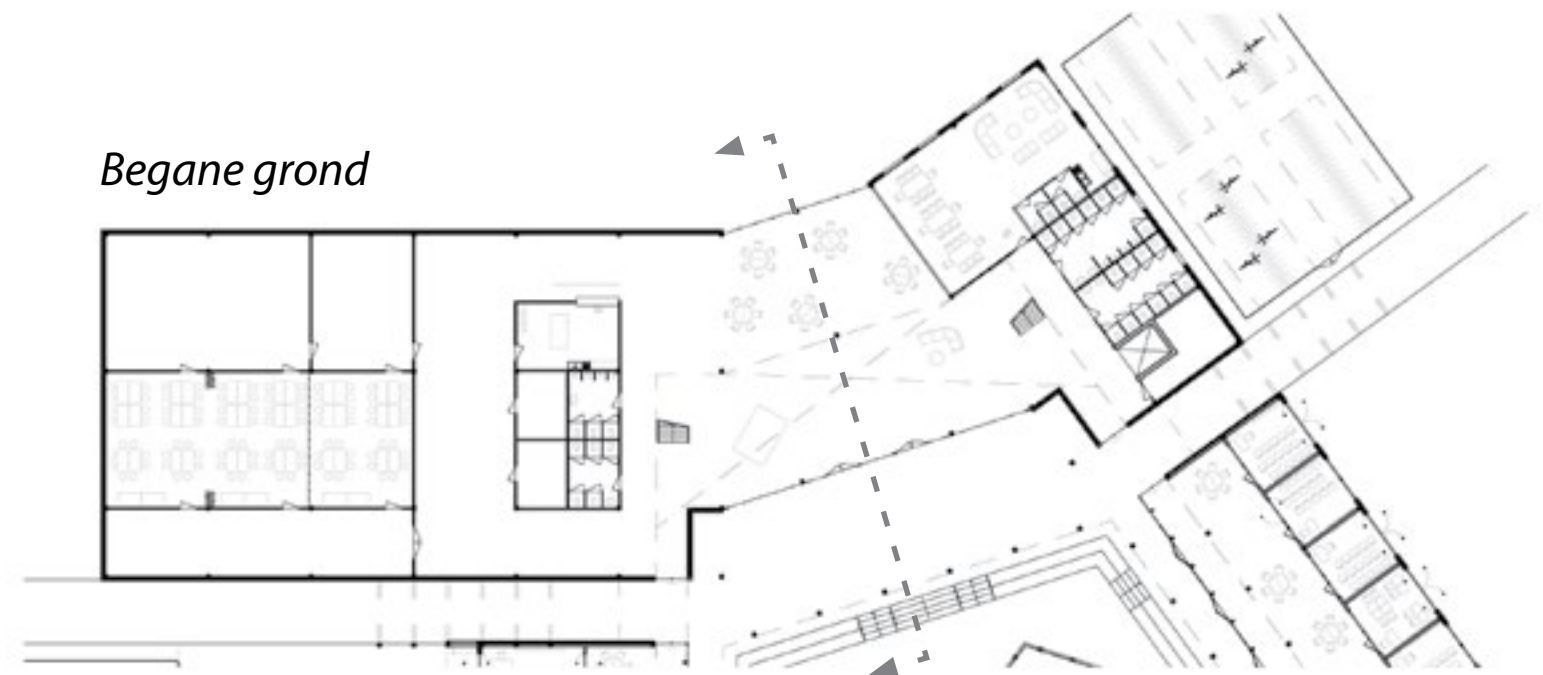

los volume
functie & gebruik

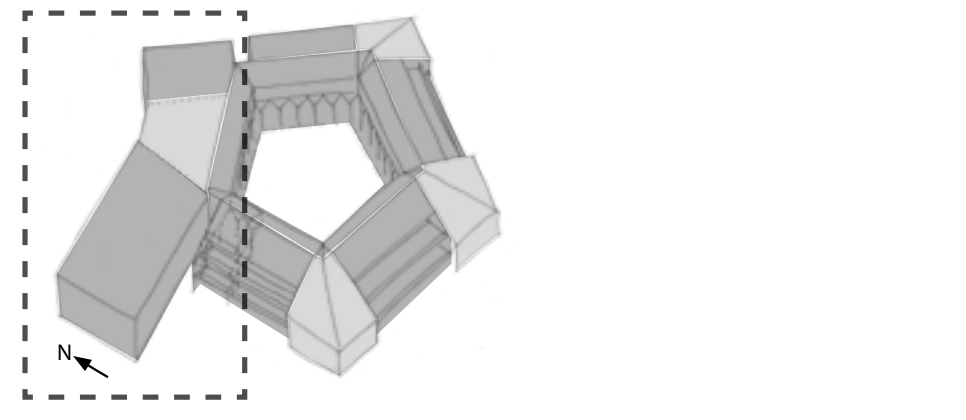

Verdieping 2

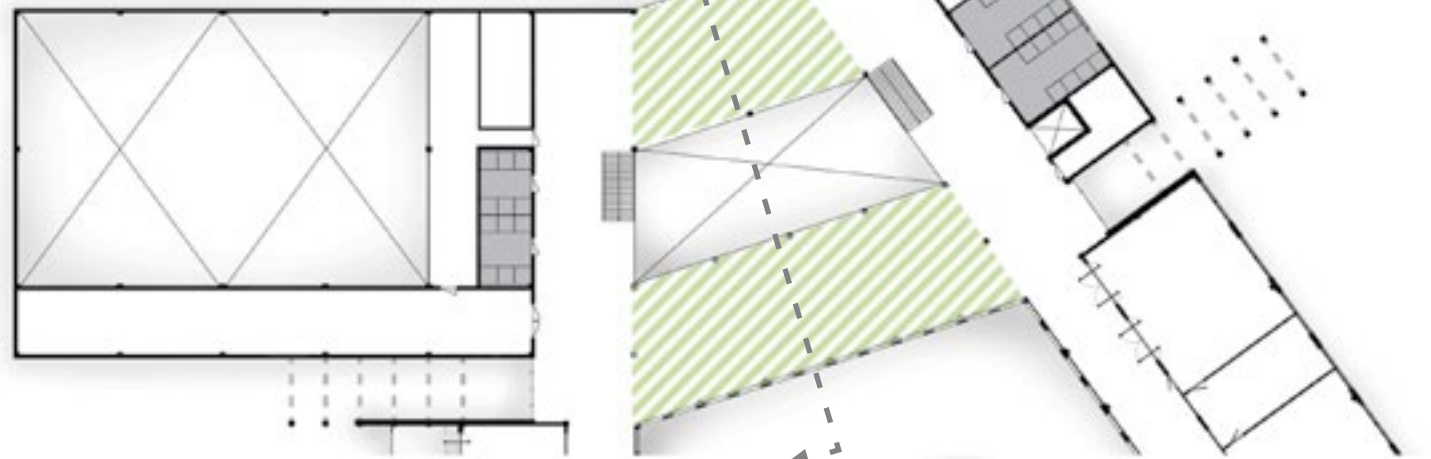



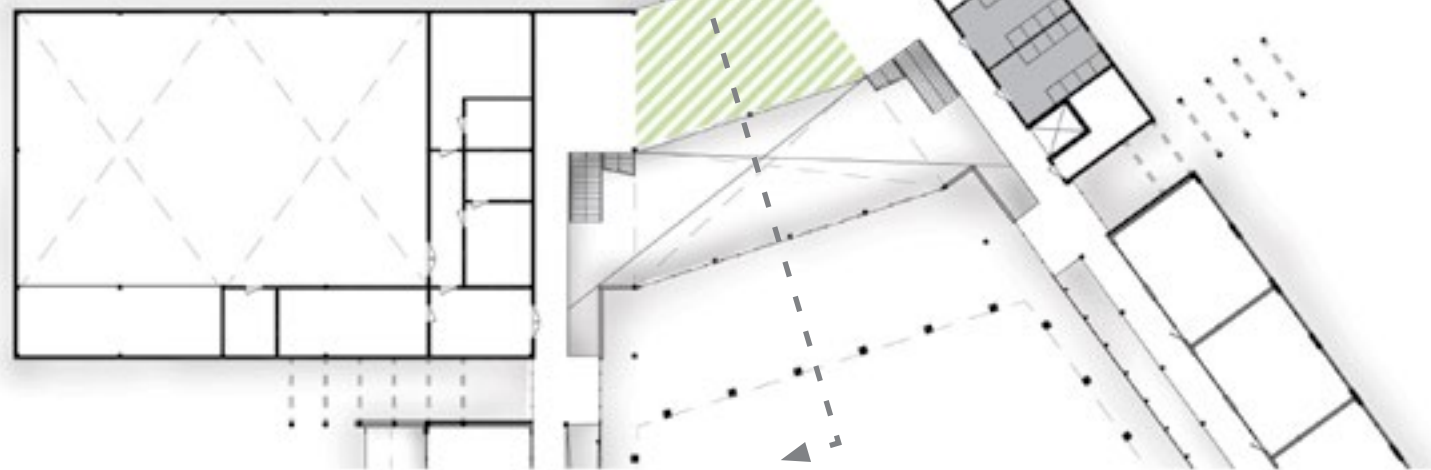

Verdieping 1

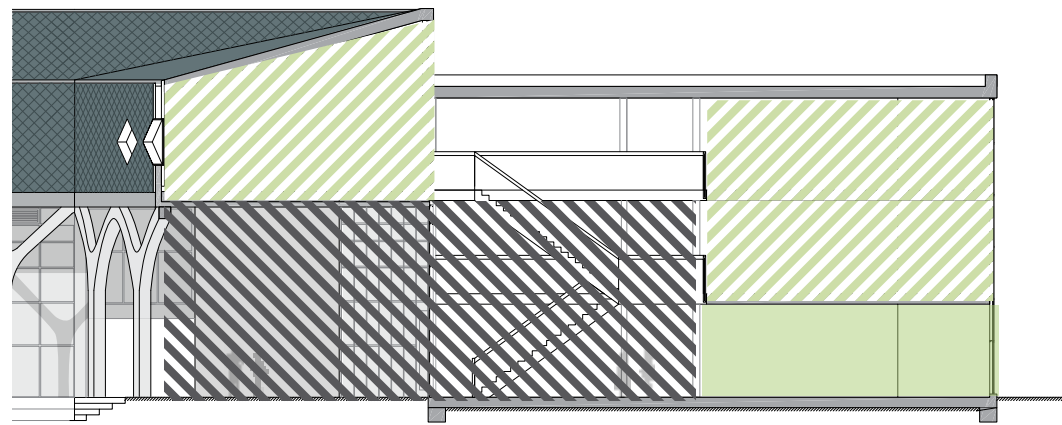
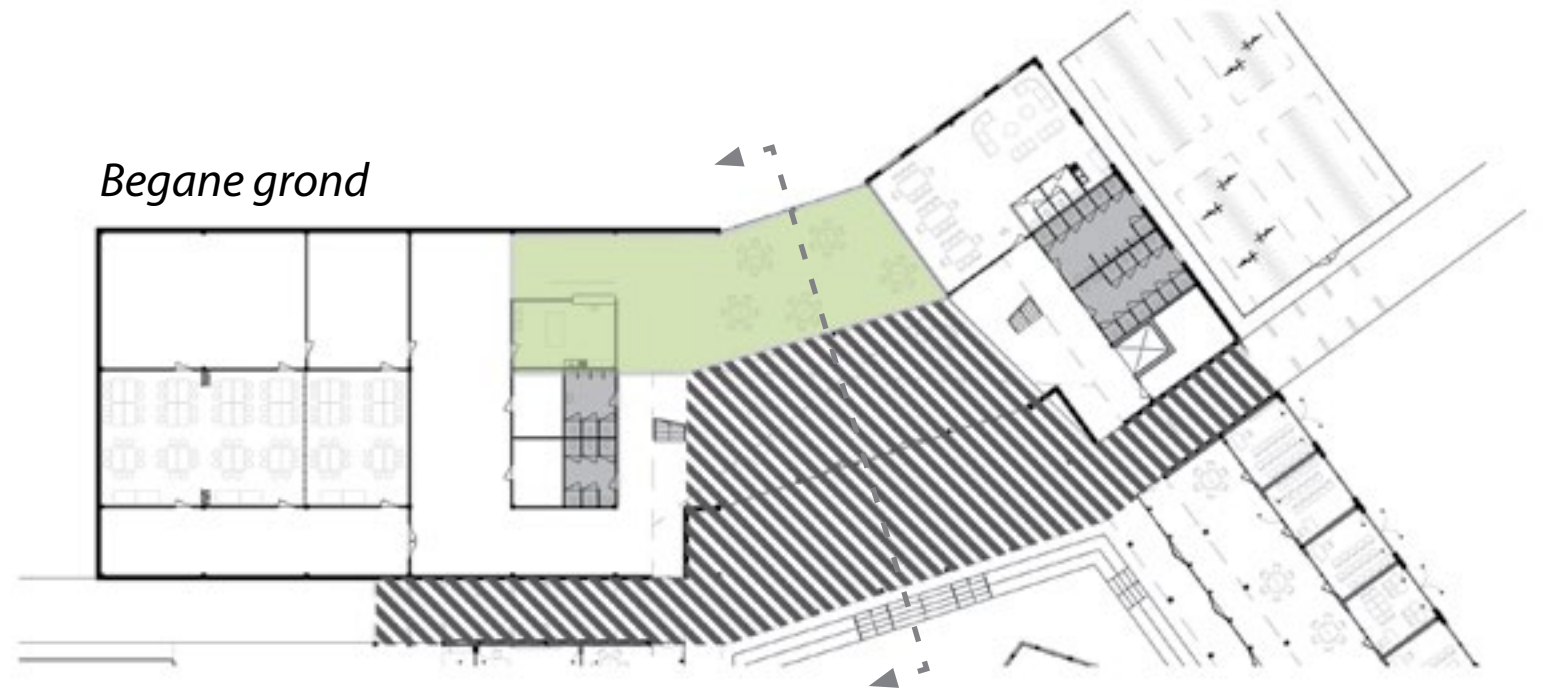

Begane grond



-  Entree zone
-  Toiletten
-  Kantine
-  Studieplekken

zijvleugels
functie & gebruik

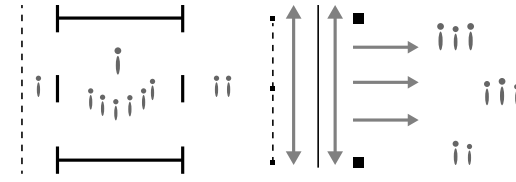
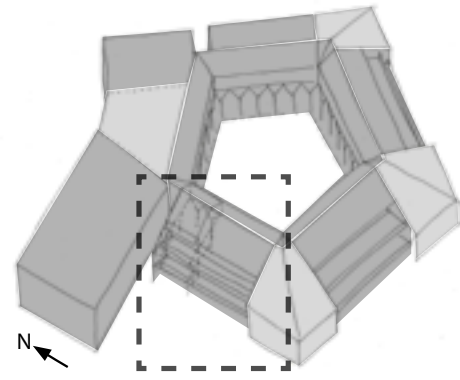

reflectie, klassikaal, samenwerken,
bufferzone, oefenen

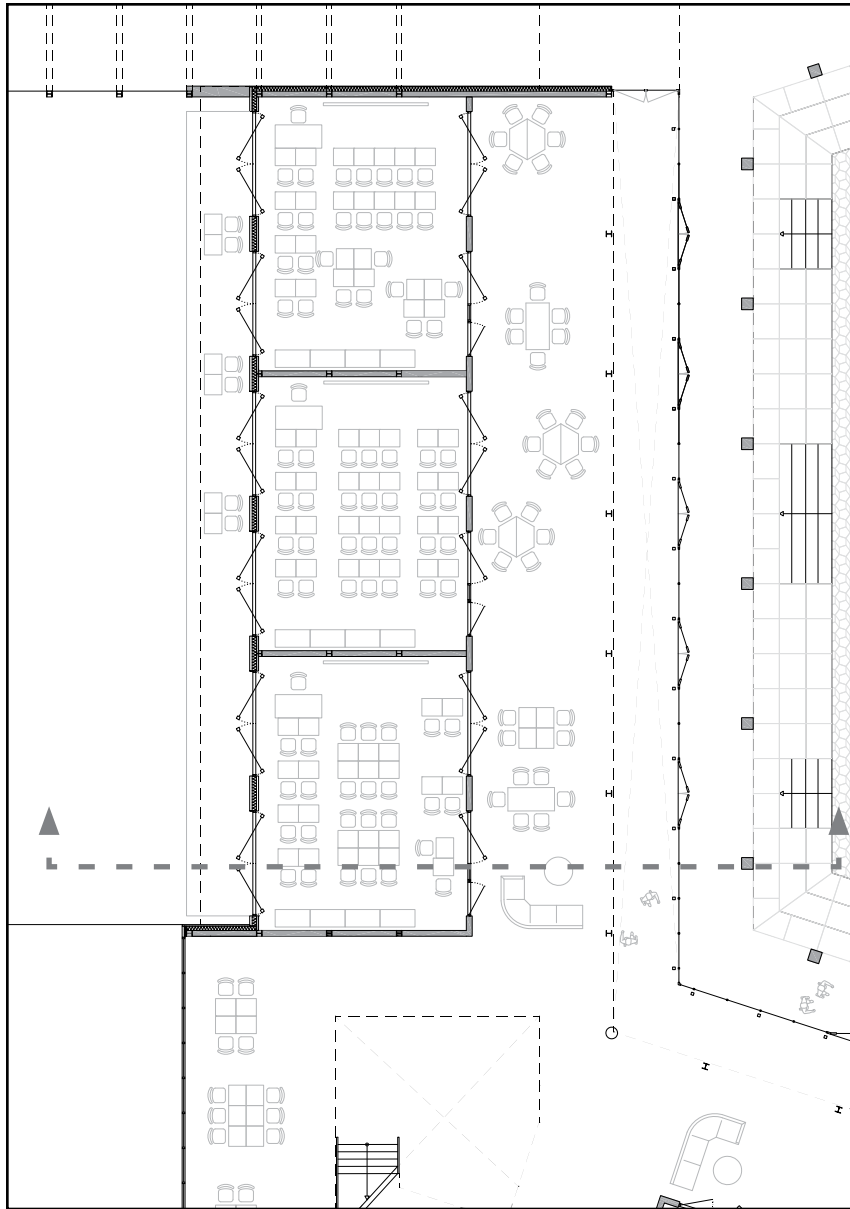
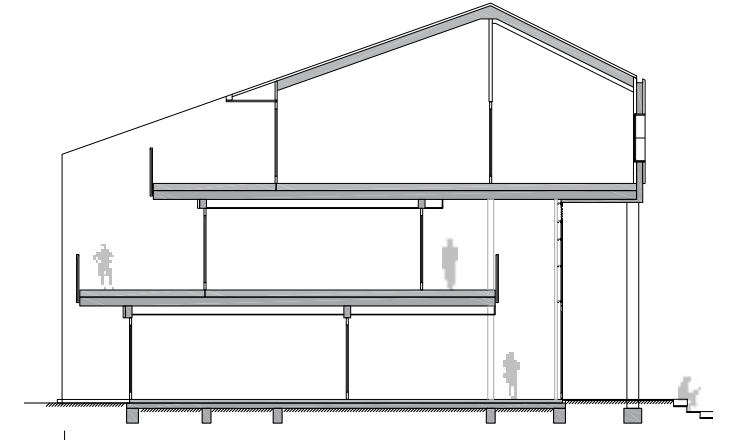

Begane grond

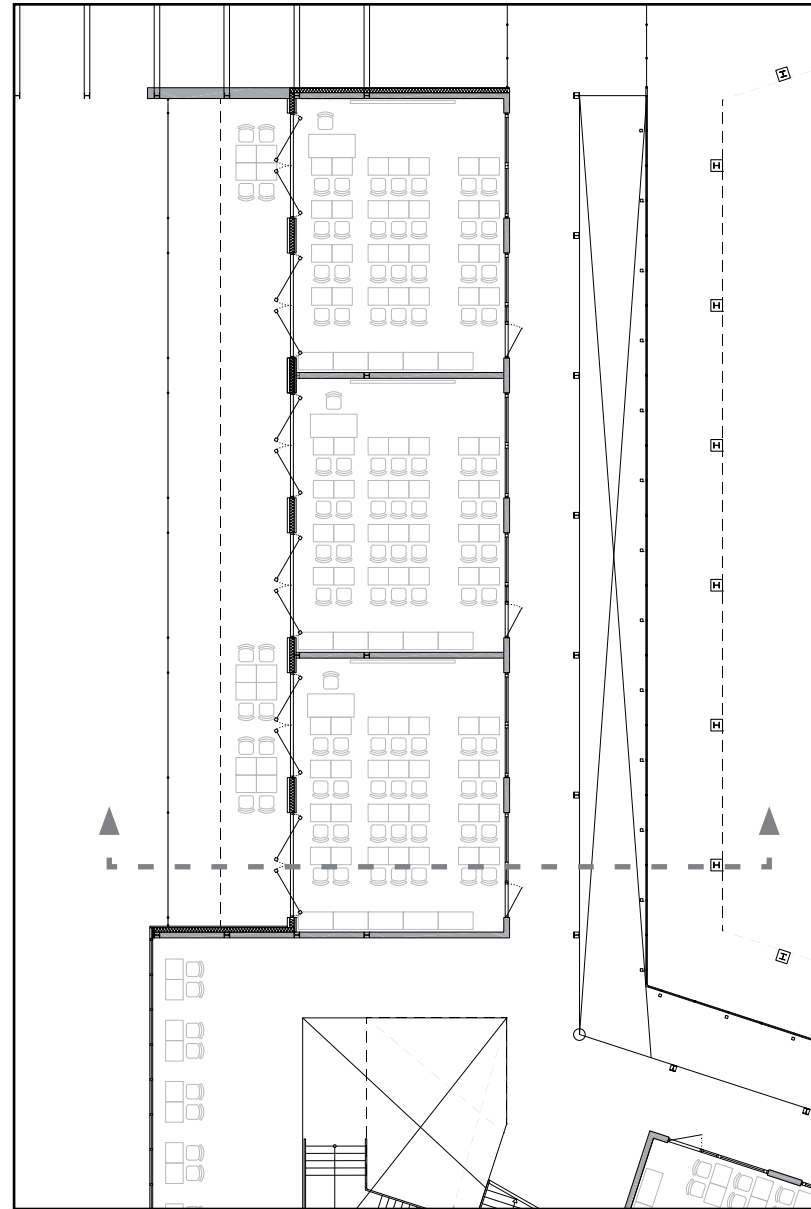

Verdieping 1

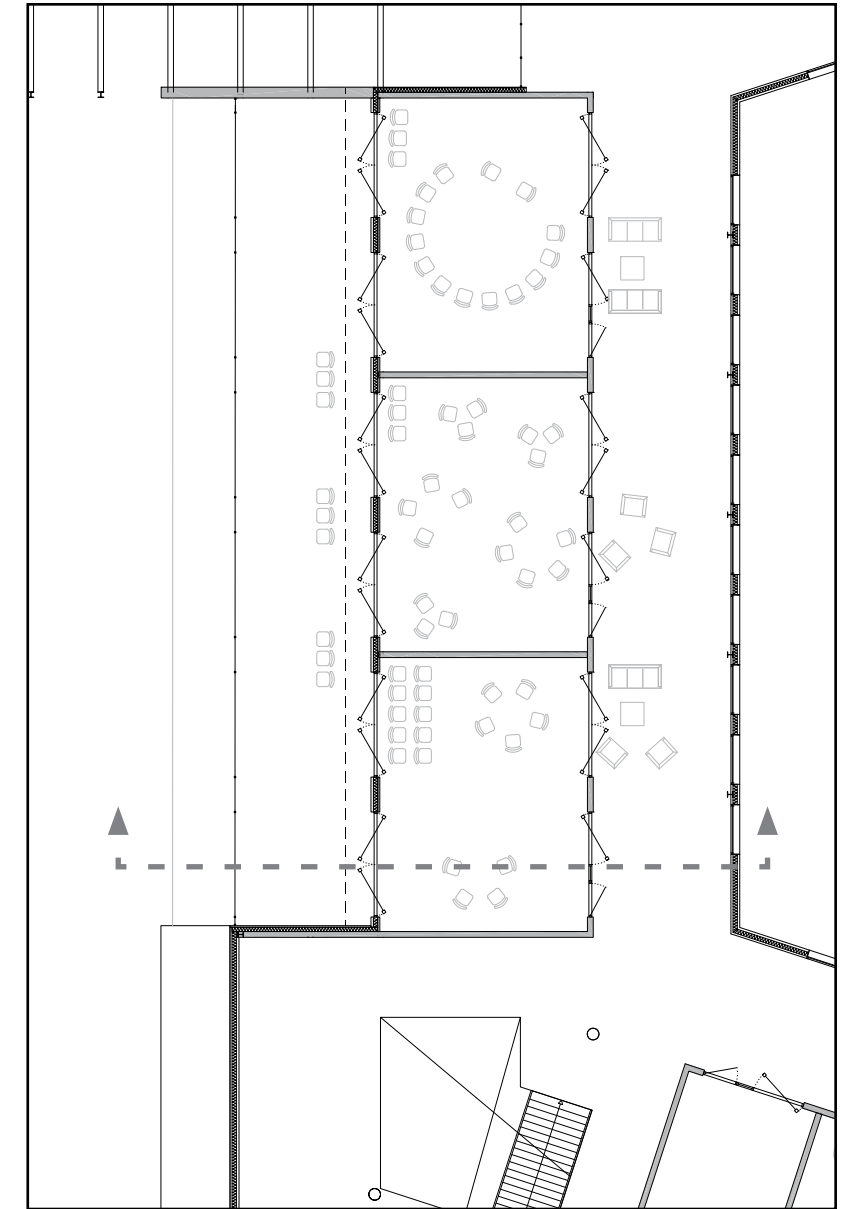

Verdieping 2

zijvleugels
functie & gebruik

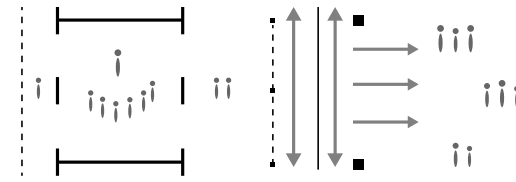
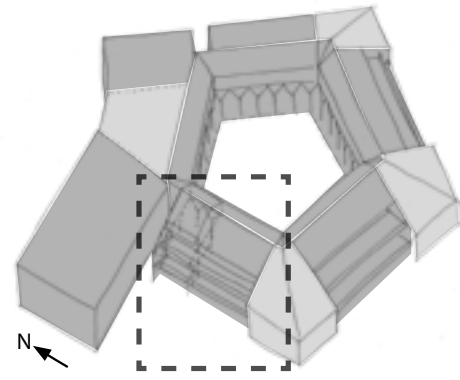

reflectie, klassikaal, samenwerken,
bufferzone, oefenen

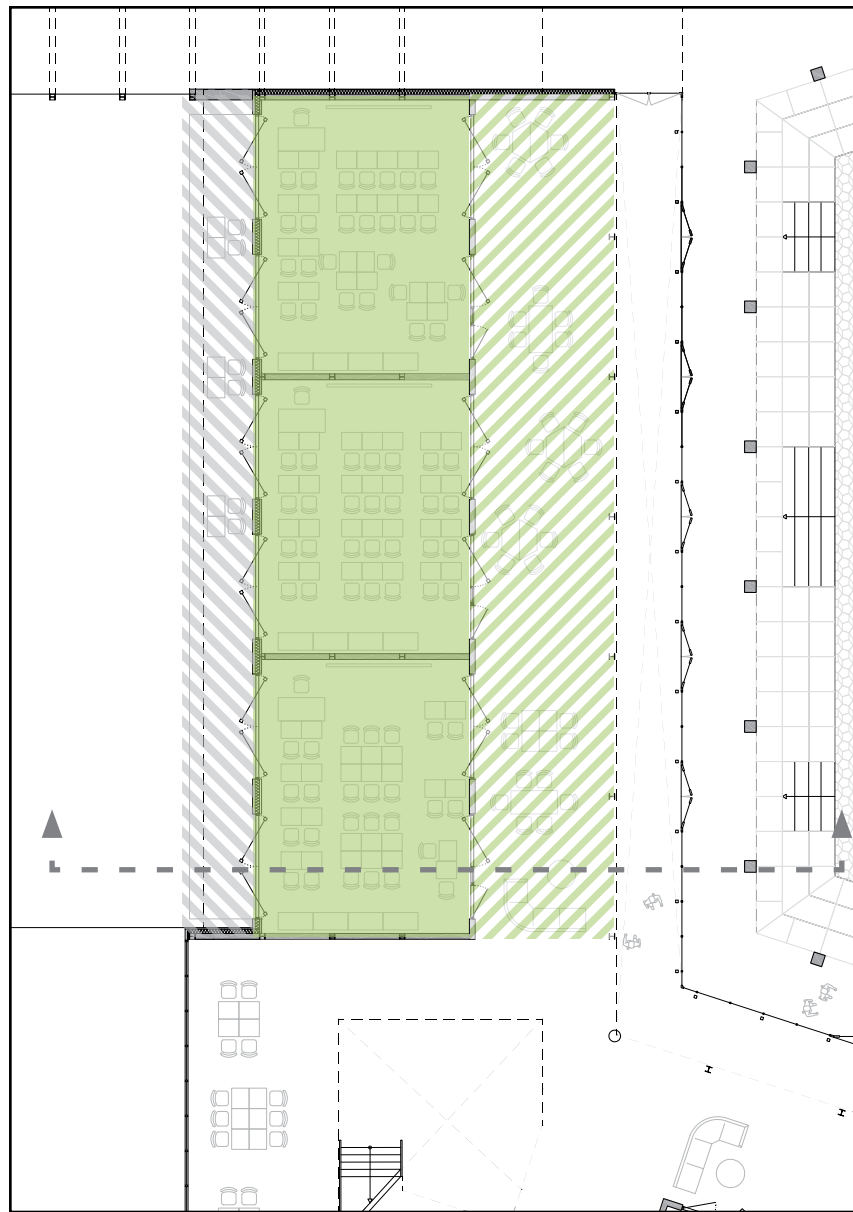
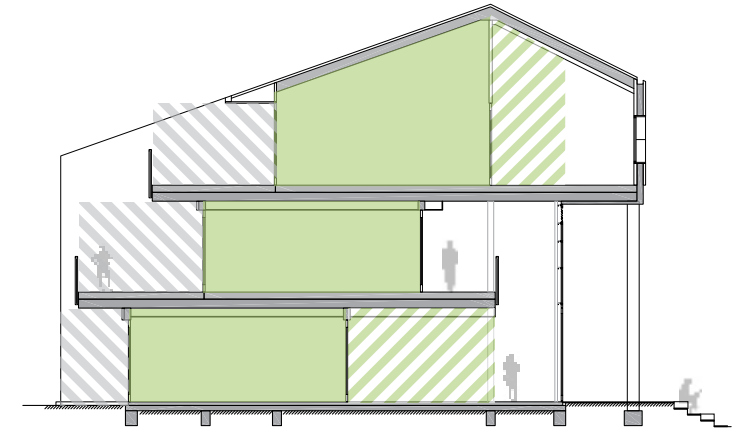

Begane grond

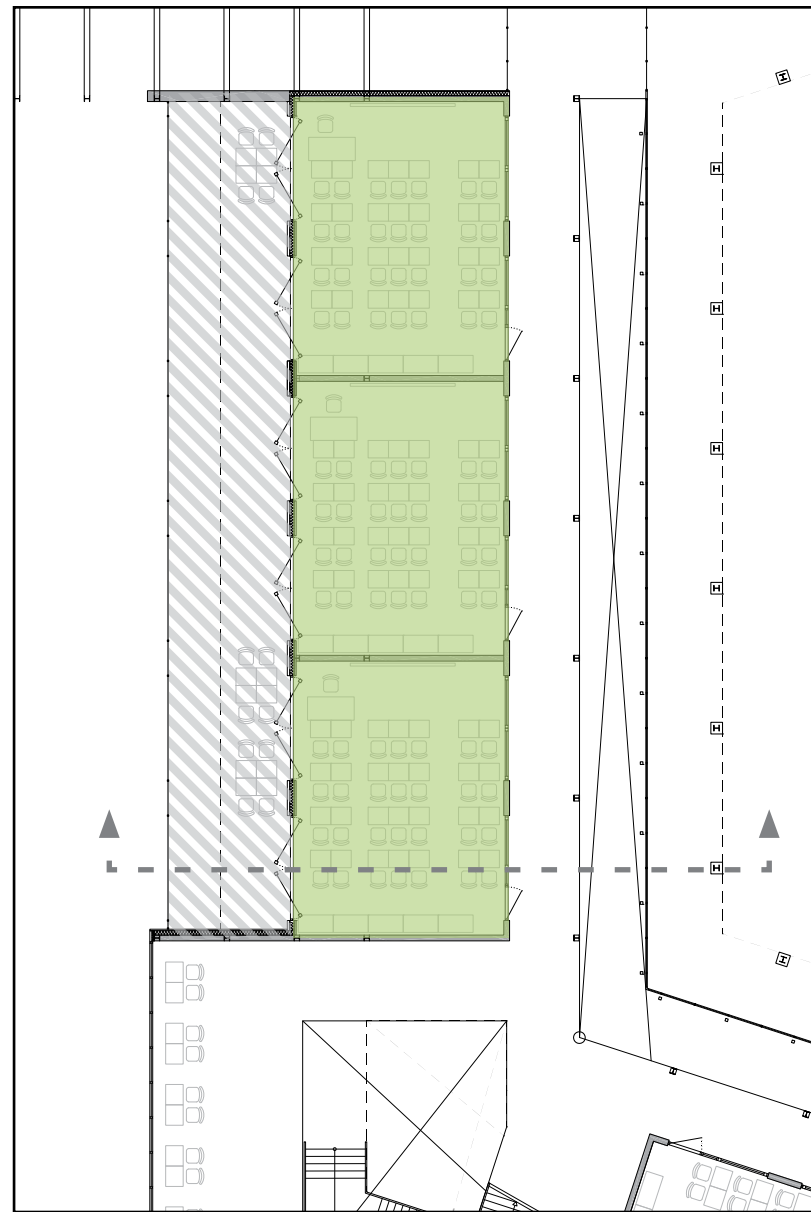

Verdieping 1

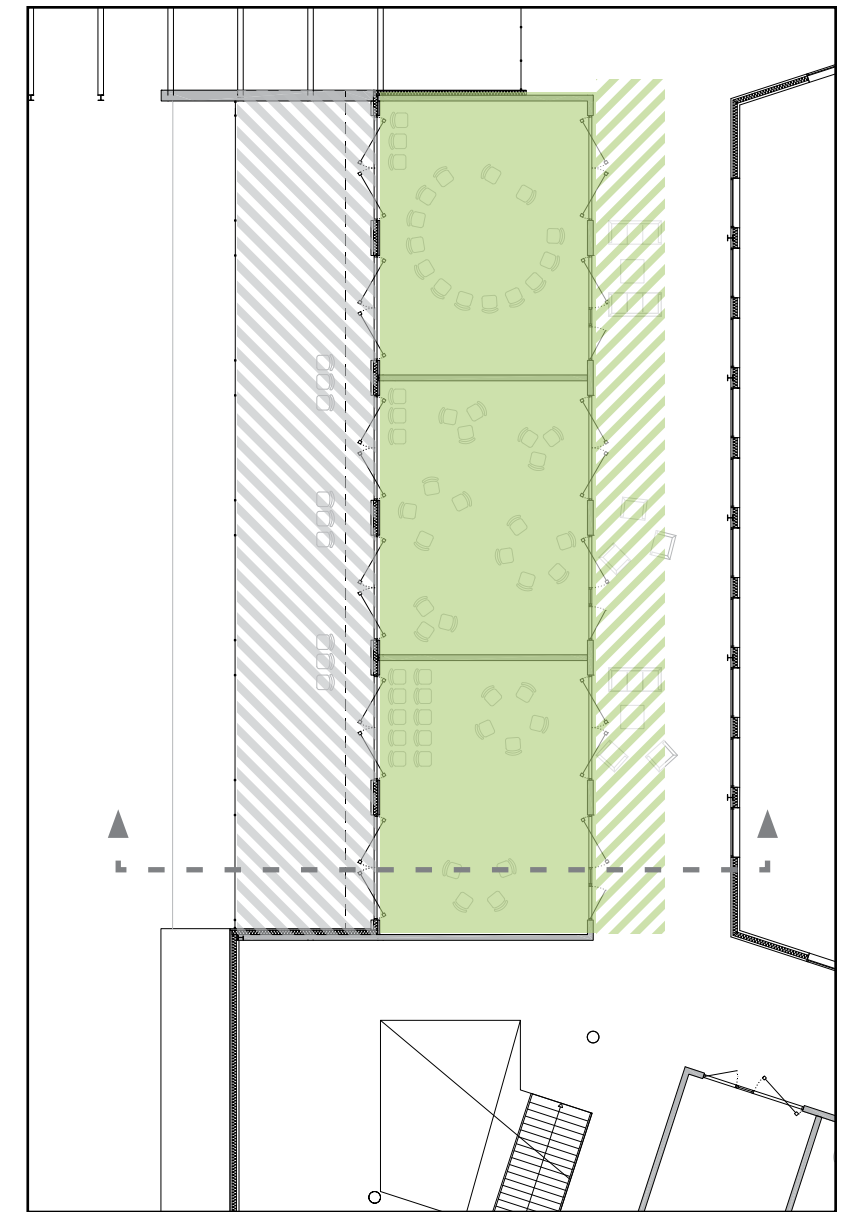

Verdieping 2

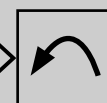
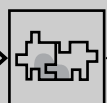
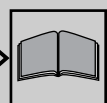

lokalen
functie & gebruik

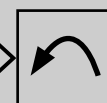
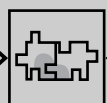
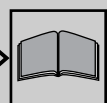
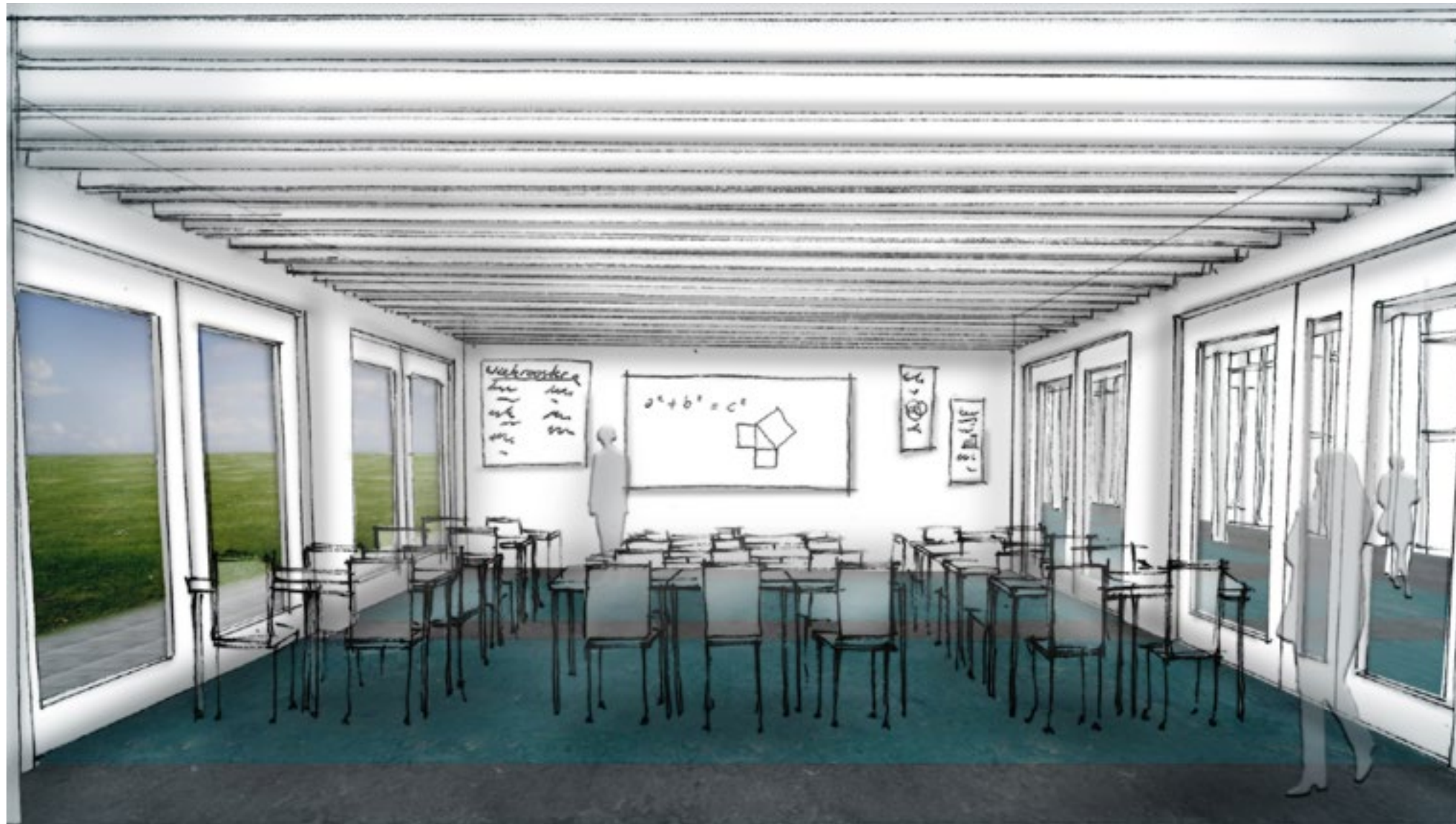
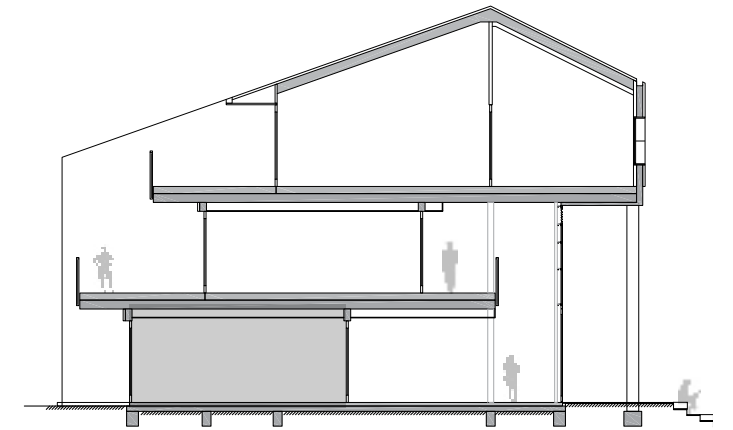
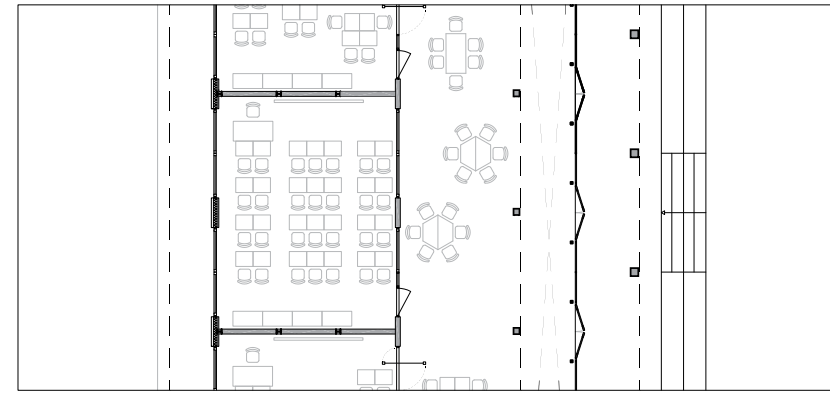
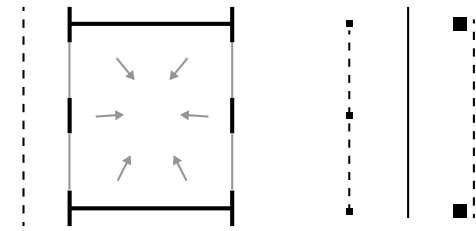
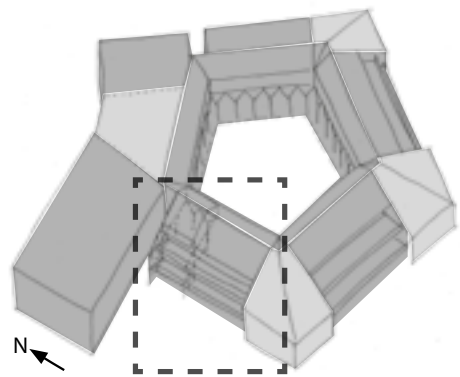

lokalen
functie & gebruik

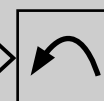
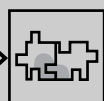
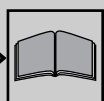
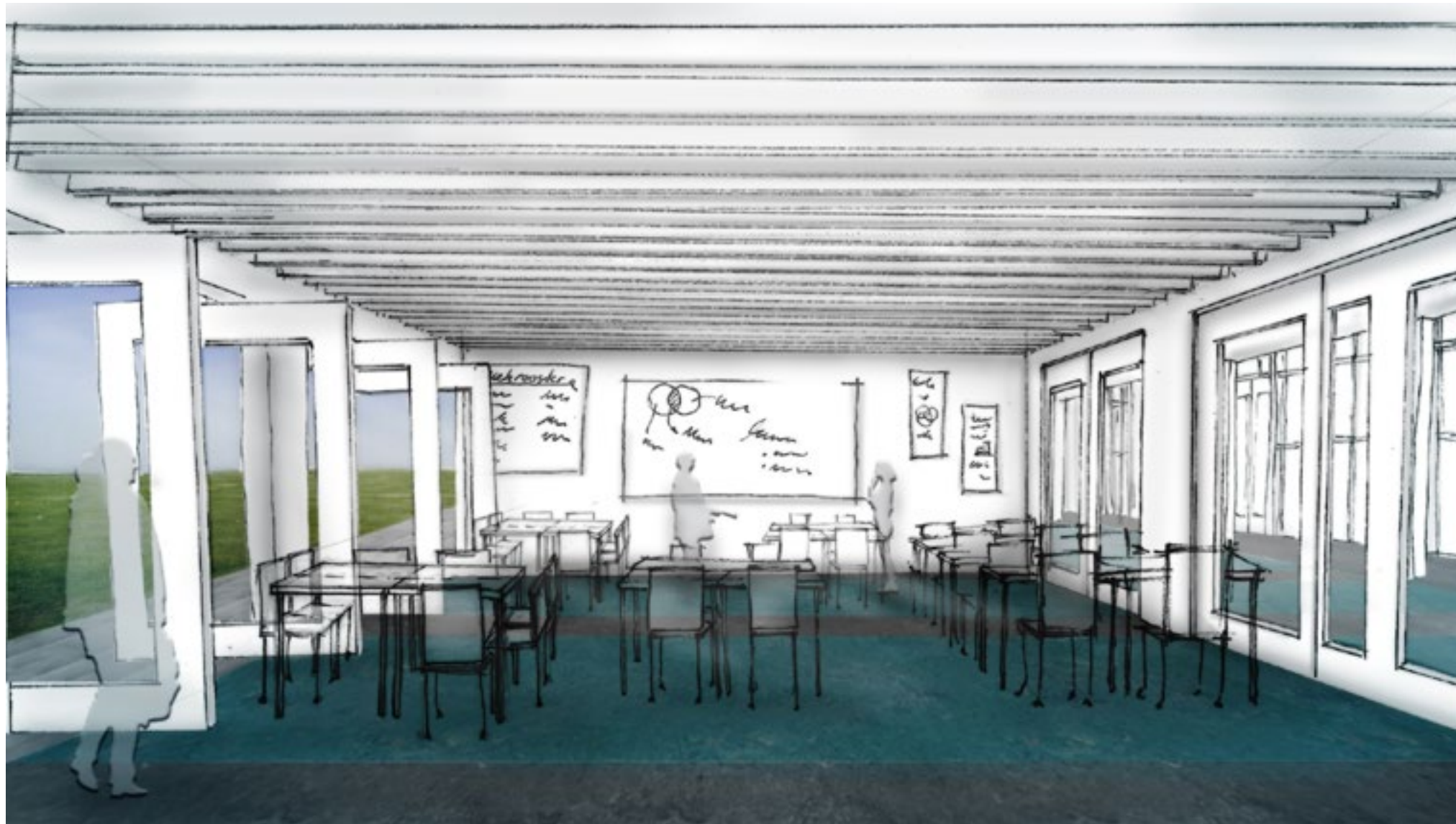
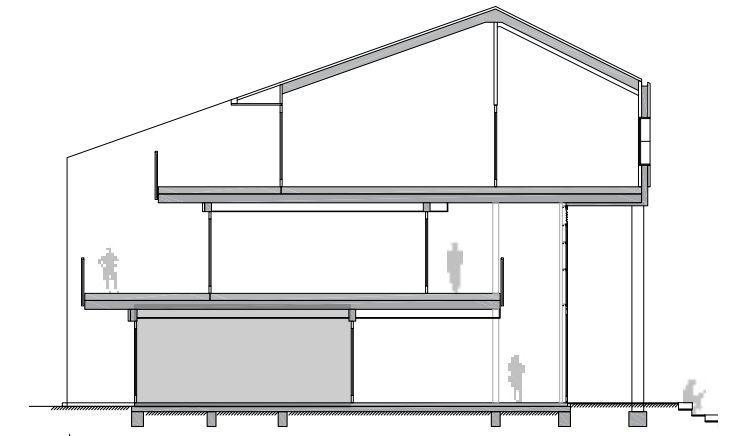
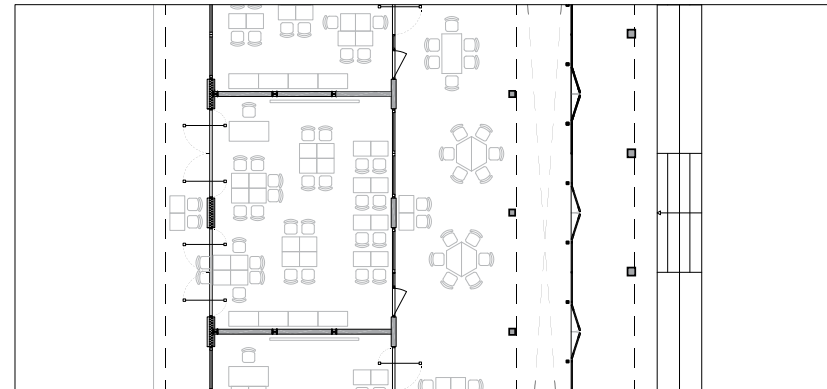
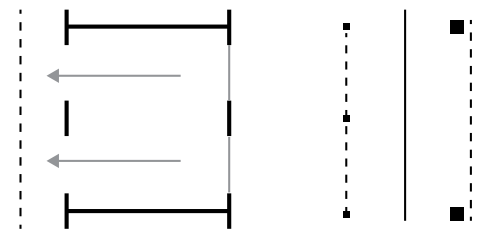
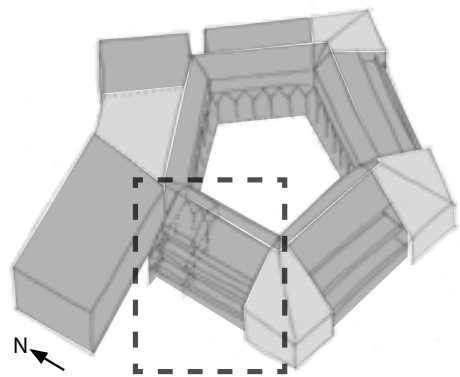

lokalen
functie & gebruik

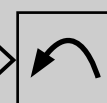
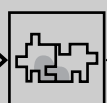
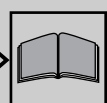
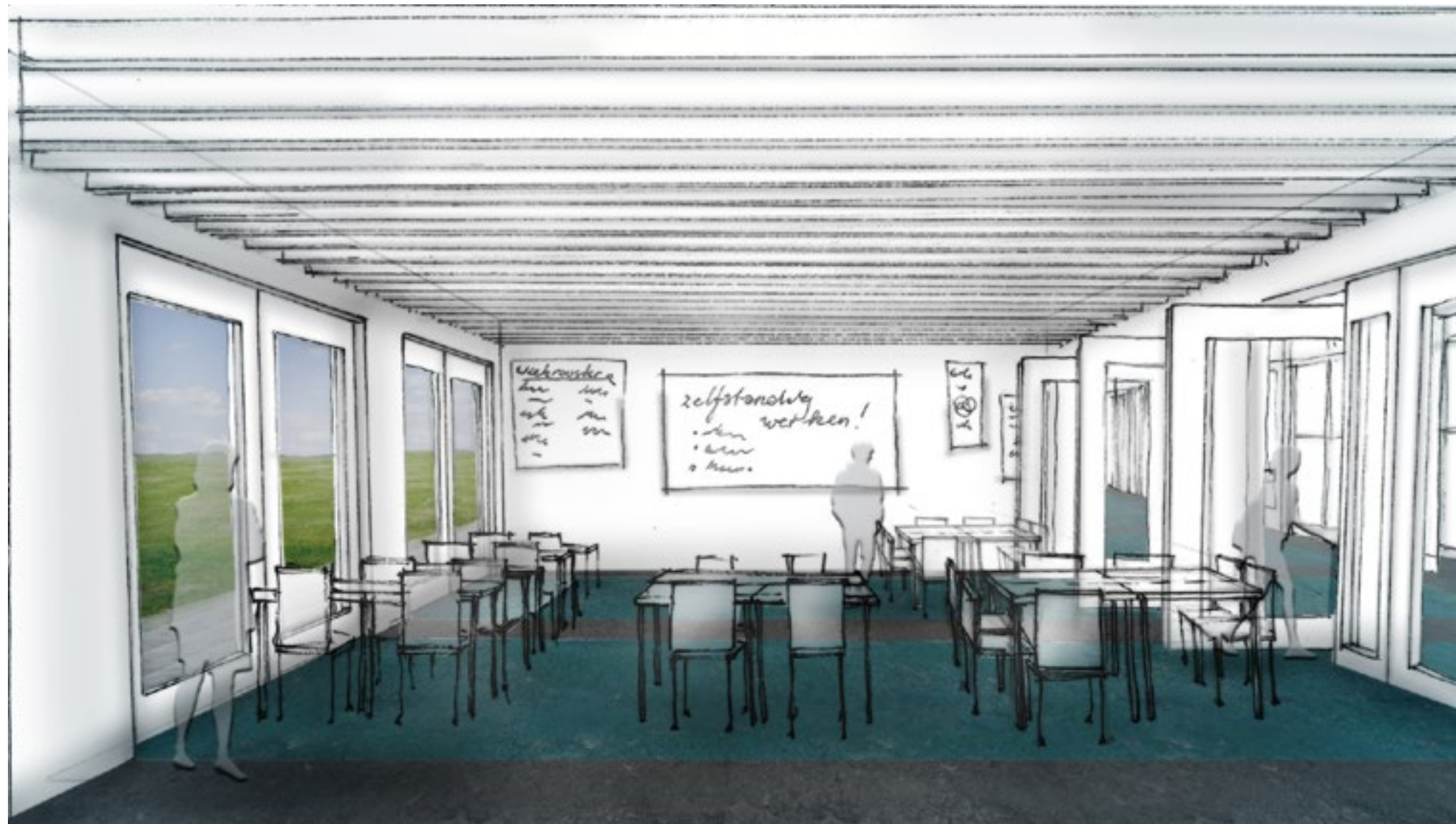
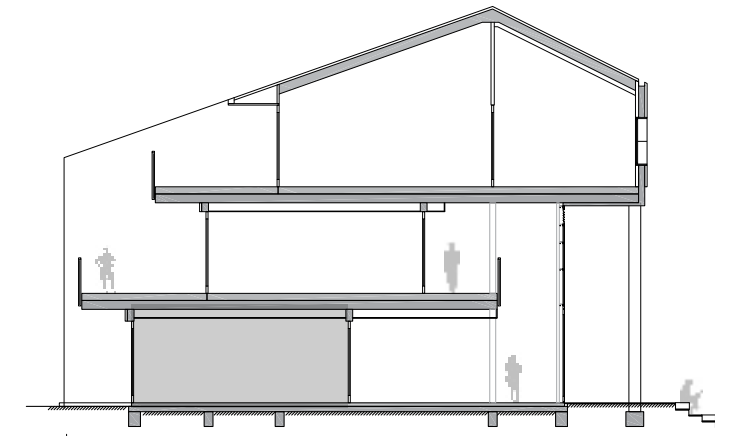
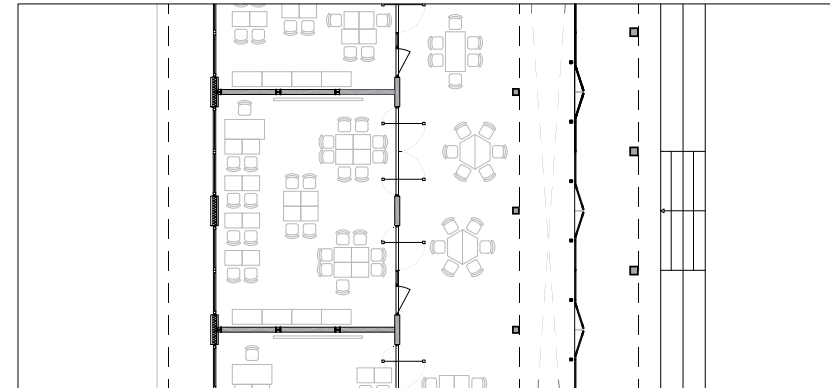
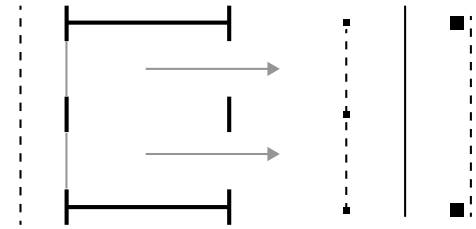
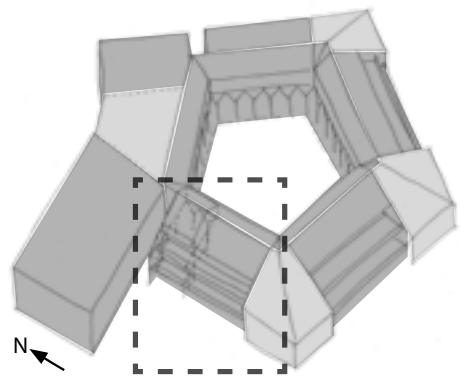

lokalen
functie & gebruik

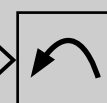
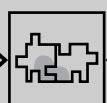
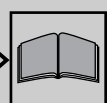
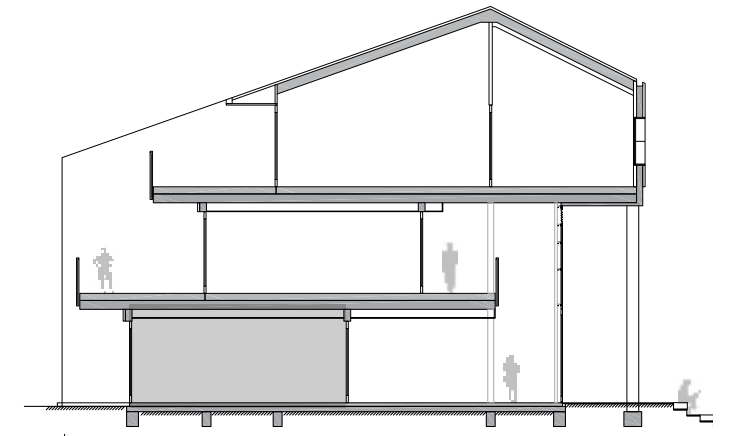
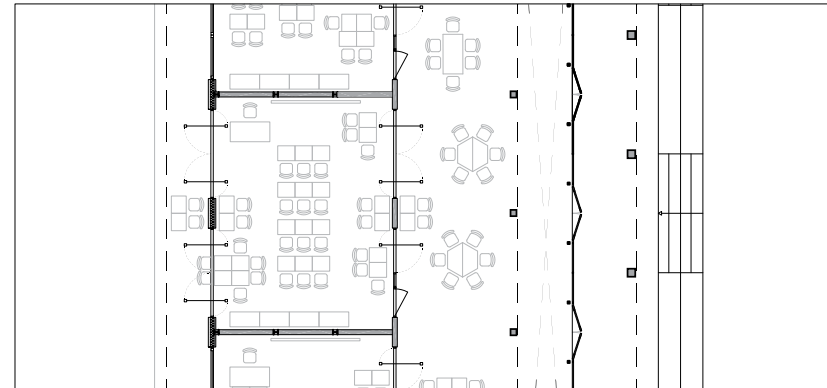
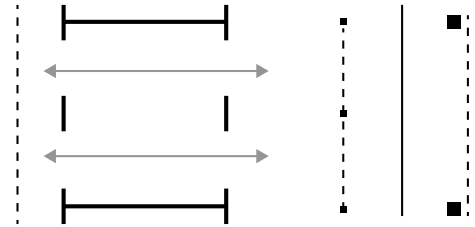
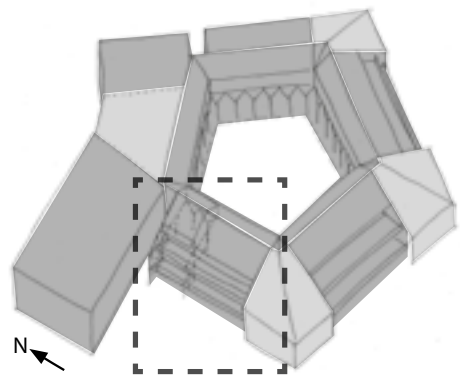

lokalen klimaat

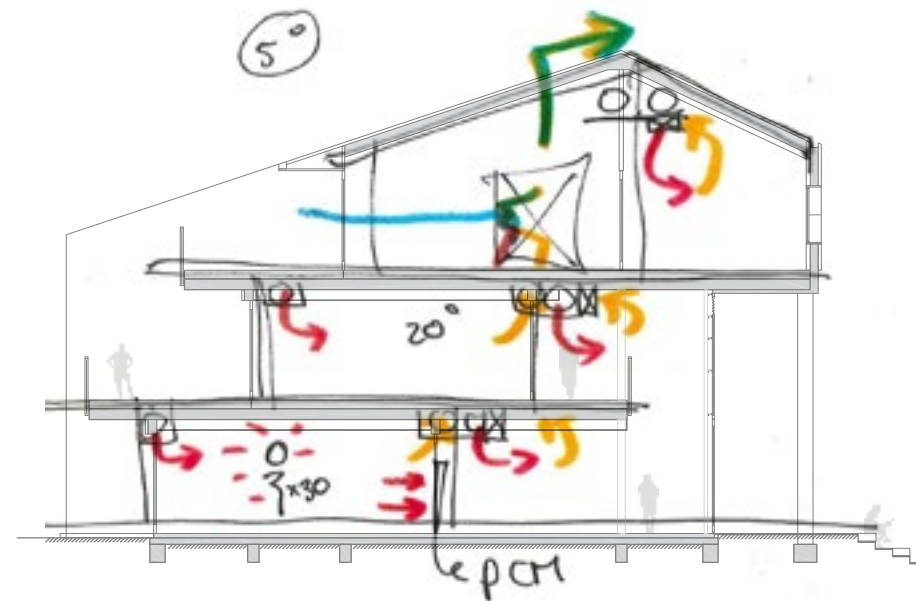
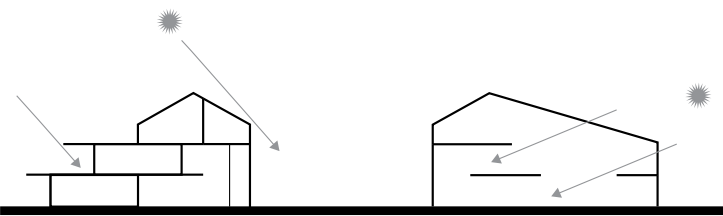
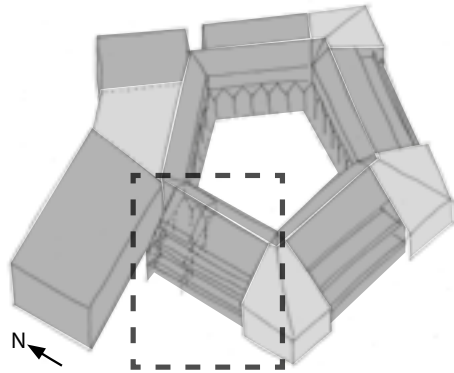

Dag winter

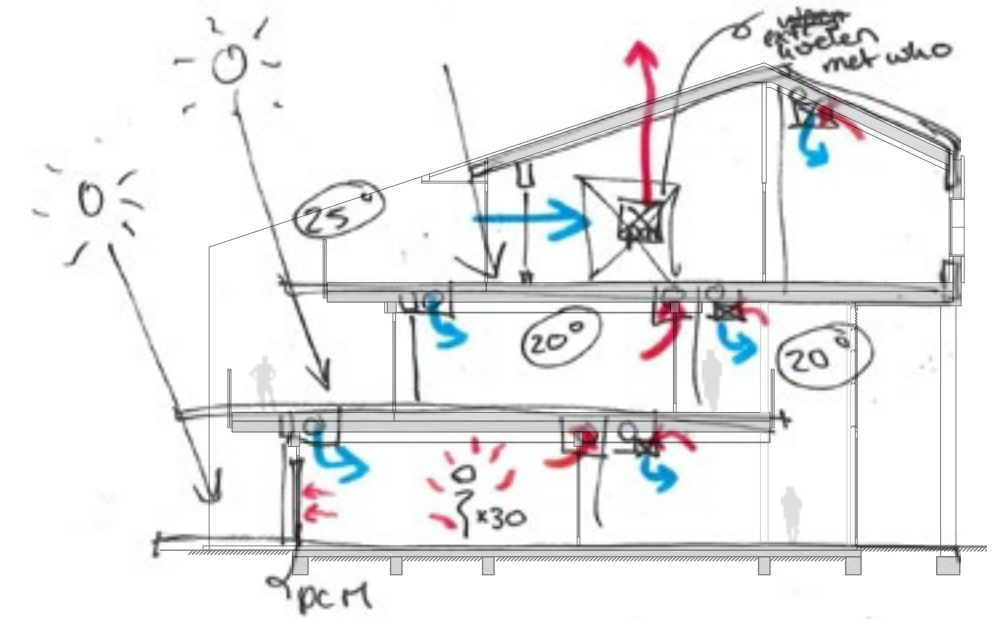

Dag zomer

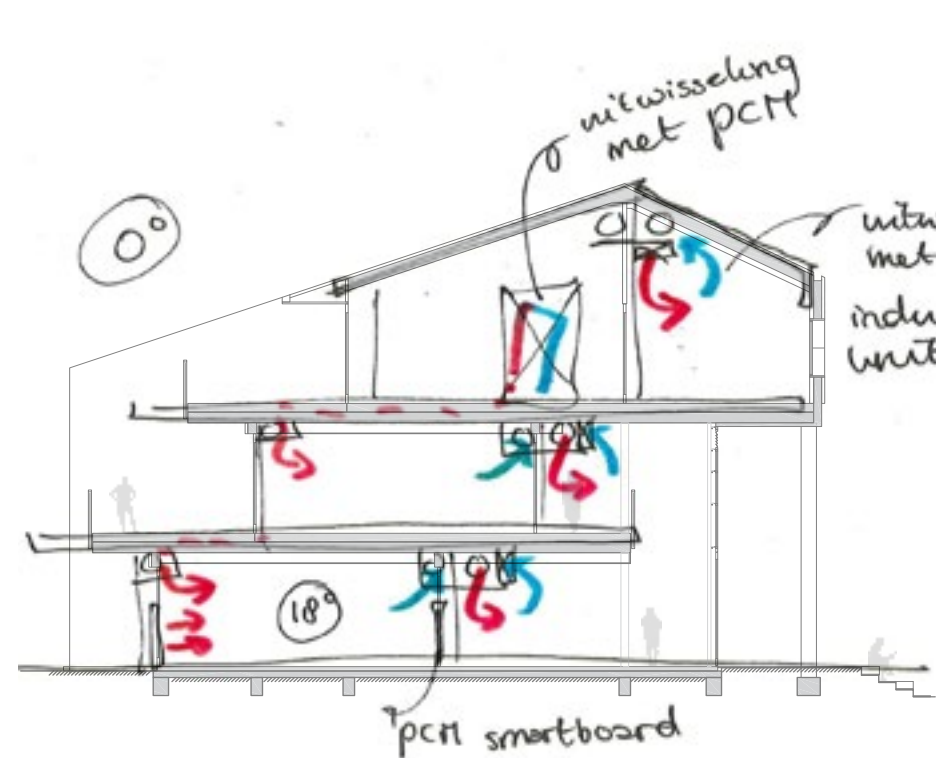

Nacht winter

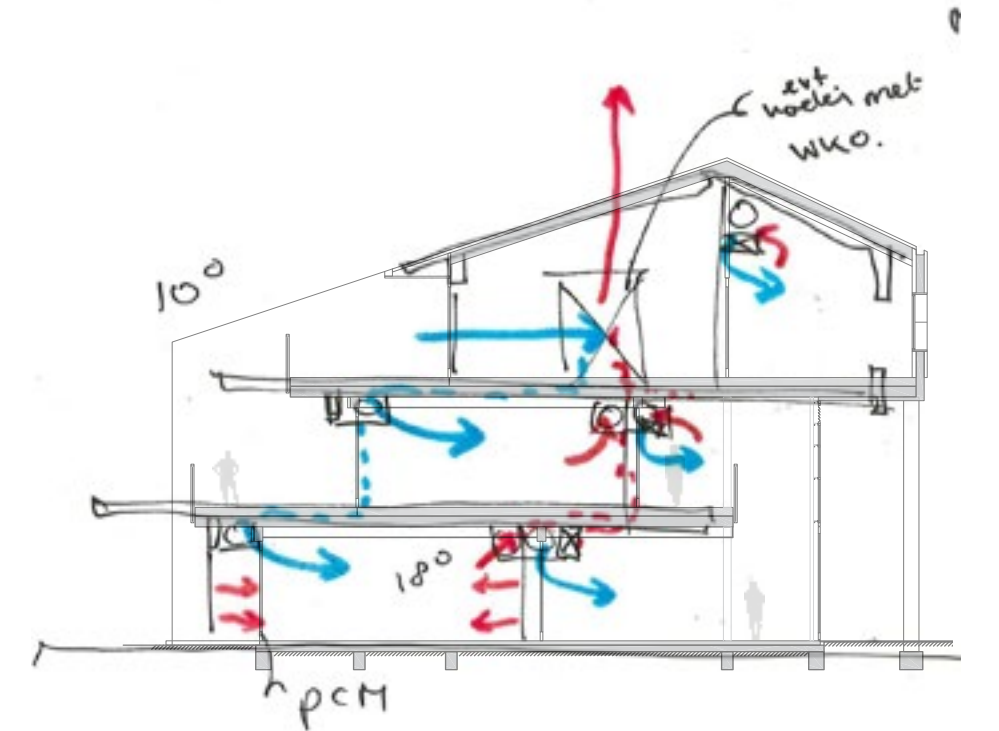

Nacht zomer

Uitdaging: koeling en ventilatie

- Warmte/koude opslag
- Luchtbehandelingskast met PCM (Phase change materials)

Lokalen

- Overstek
- PCM op wanden

Open ruimtes

- PCM inductieunits

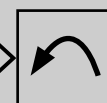
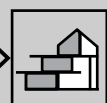
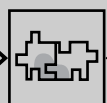
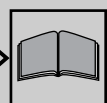

gang
functie & gebruik

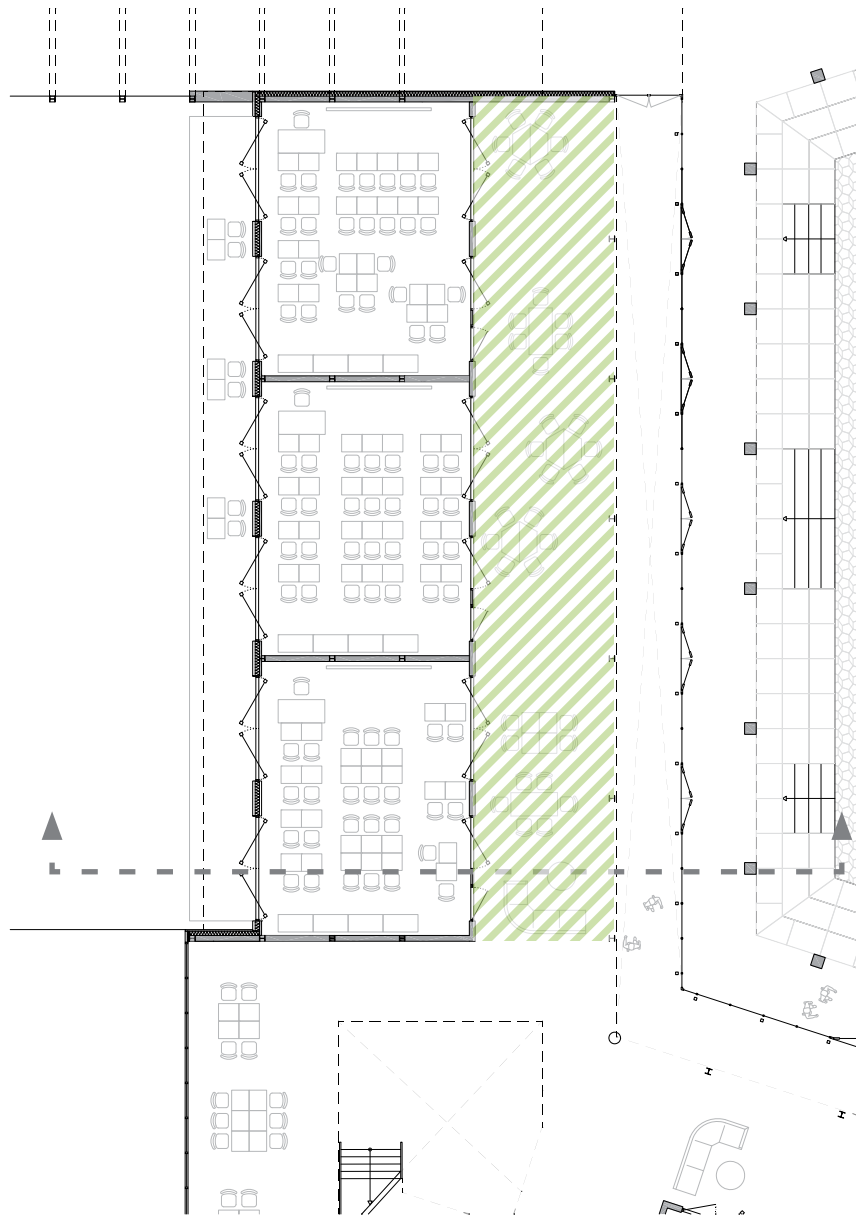
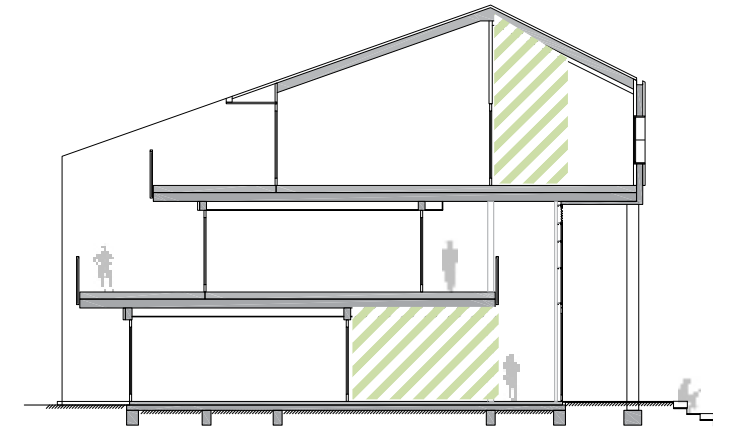
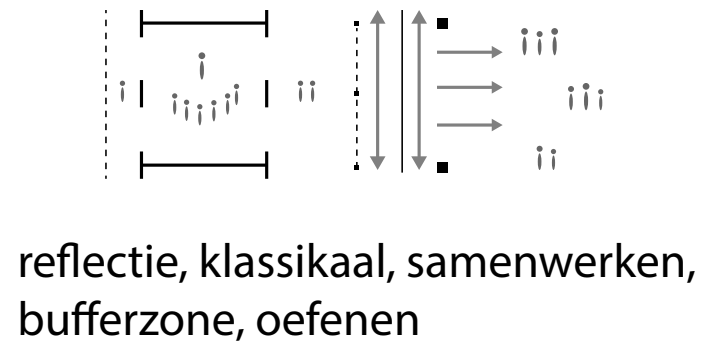
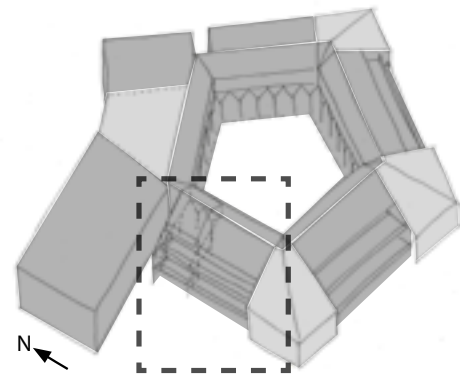

Begane grond

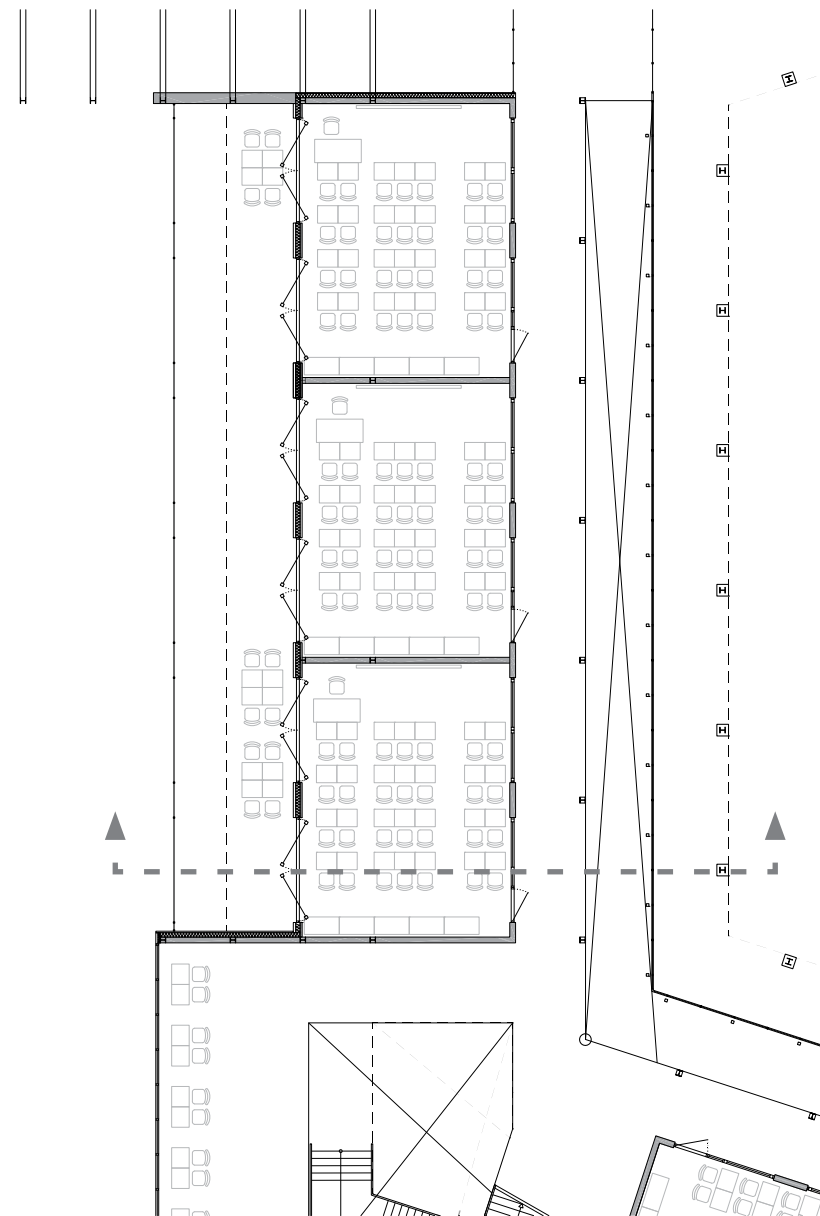

Verdieping 1

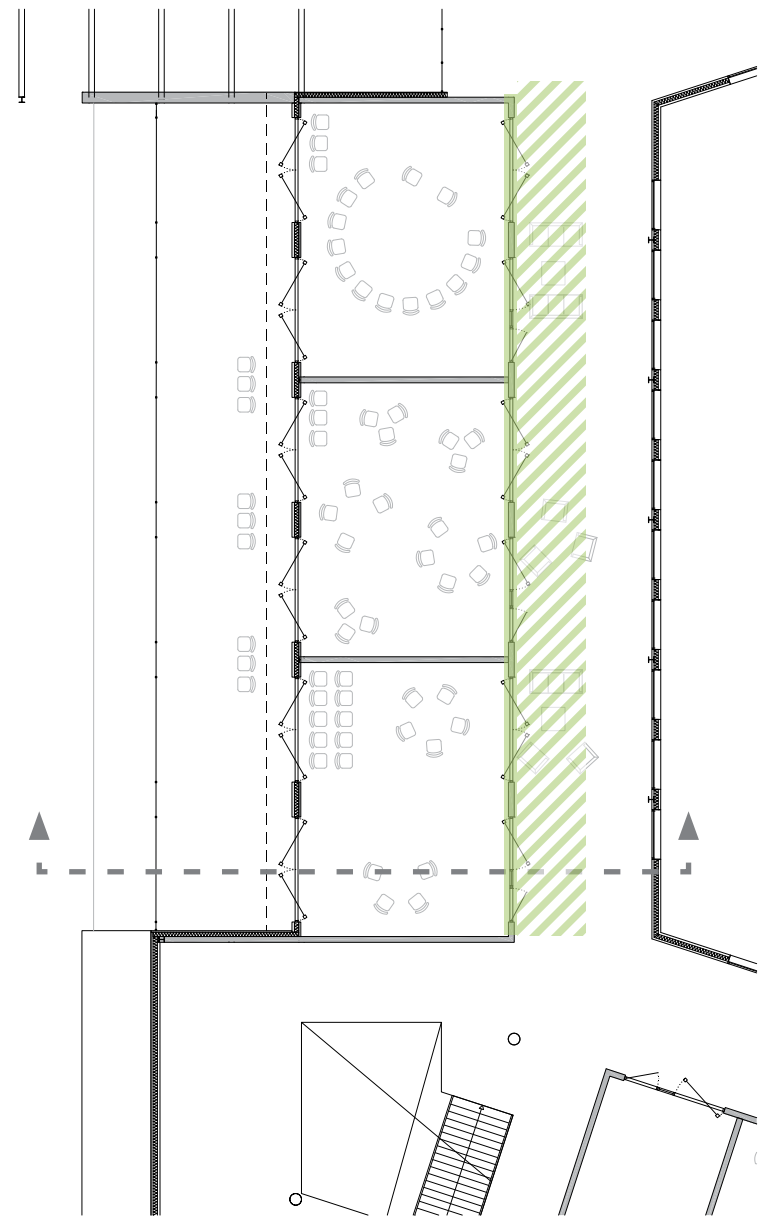

Verdieping 2

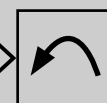
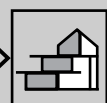
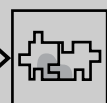
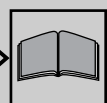

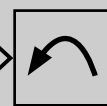
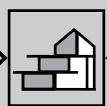
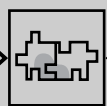
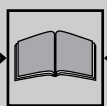

balkons
functie & gebruik

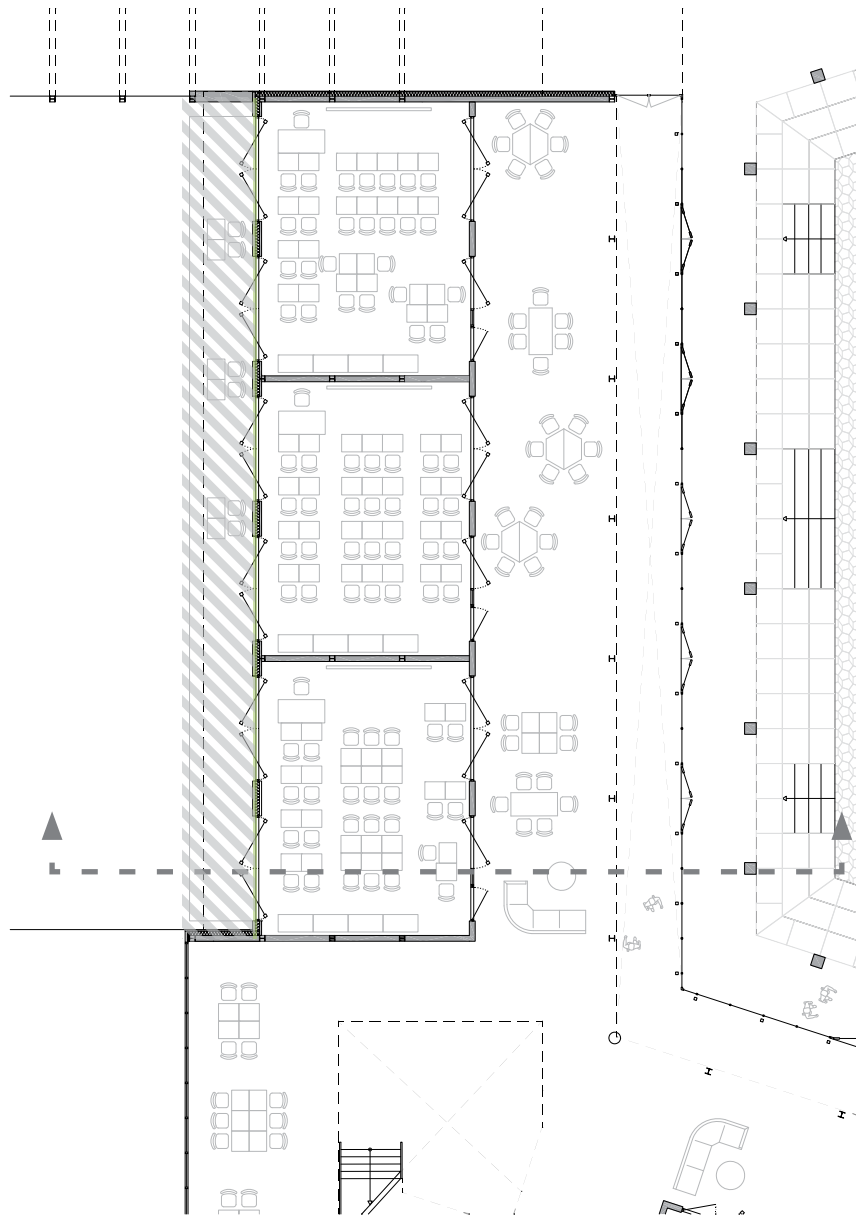
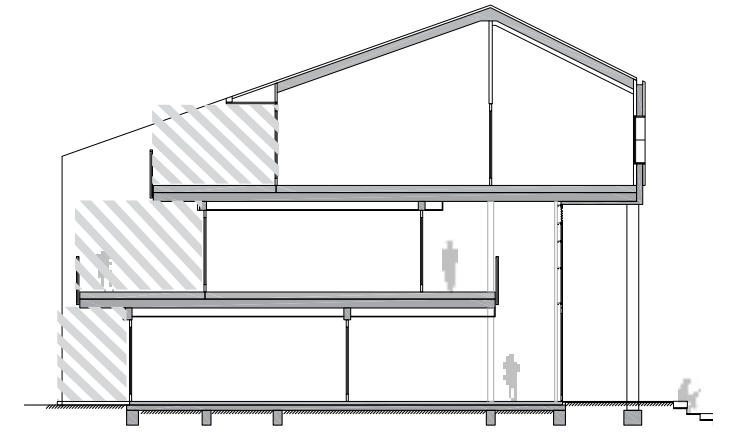
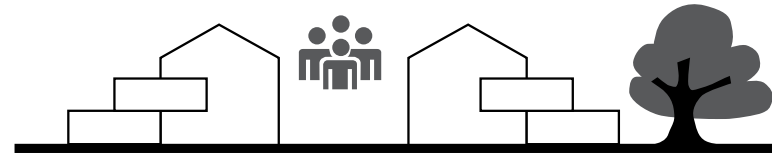
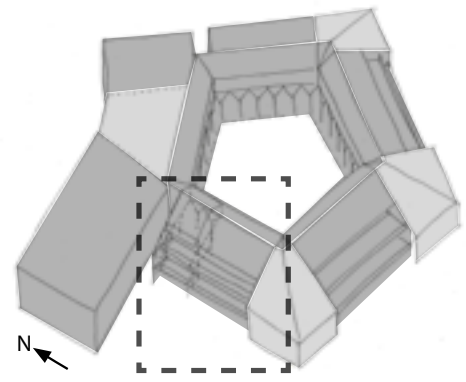

Begane grond

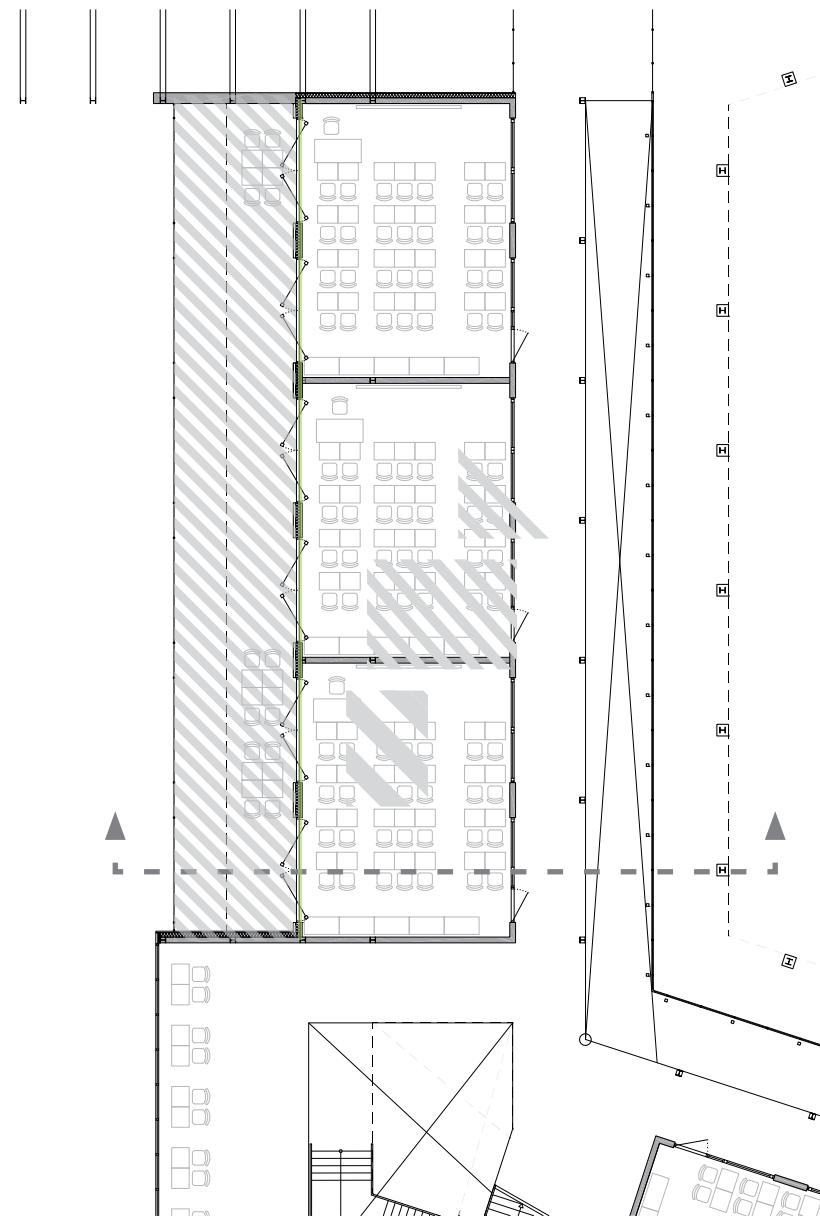

Verdieping 1

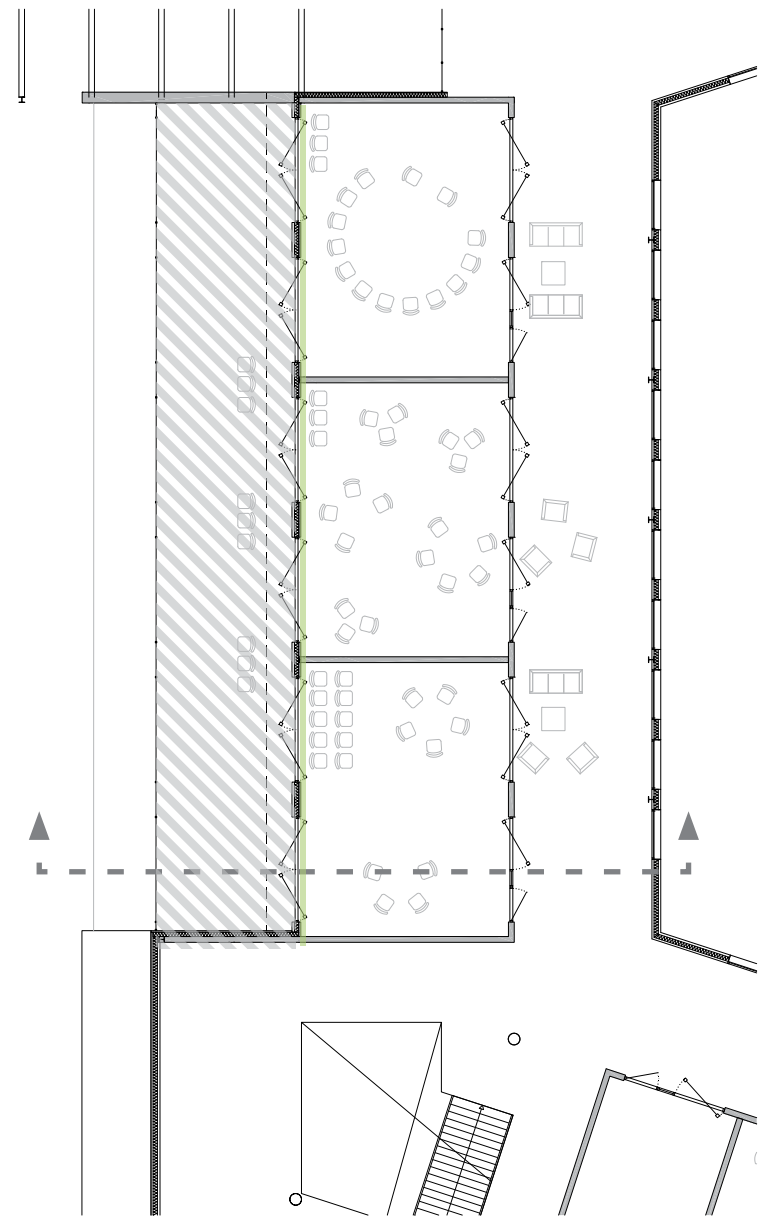

Verdieping 2

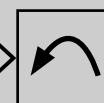
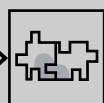
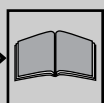

Terugkoppeling

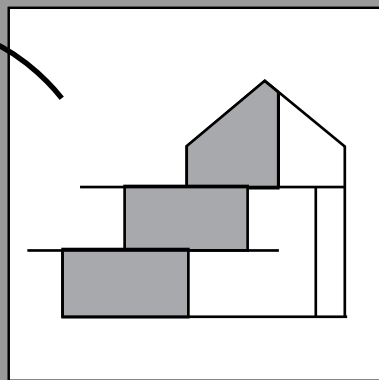
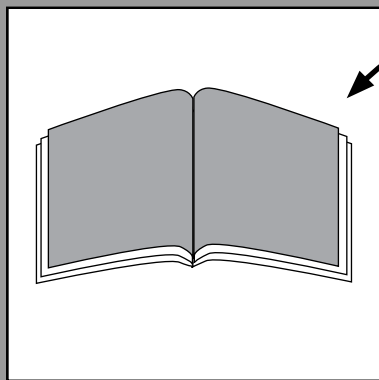

Herhaling van het principe

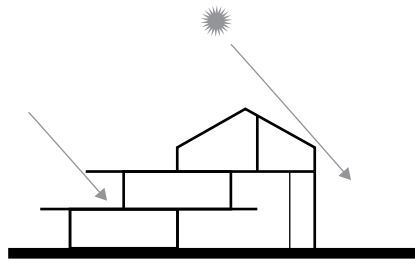

zijvleugels

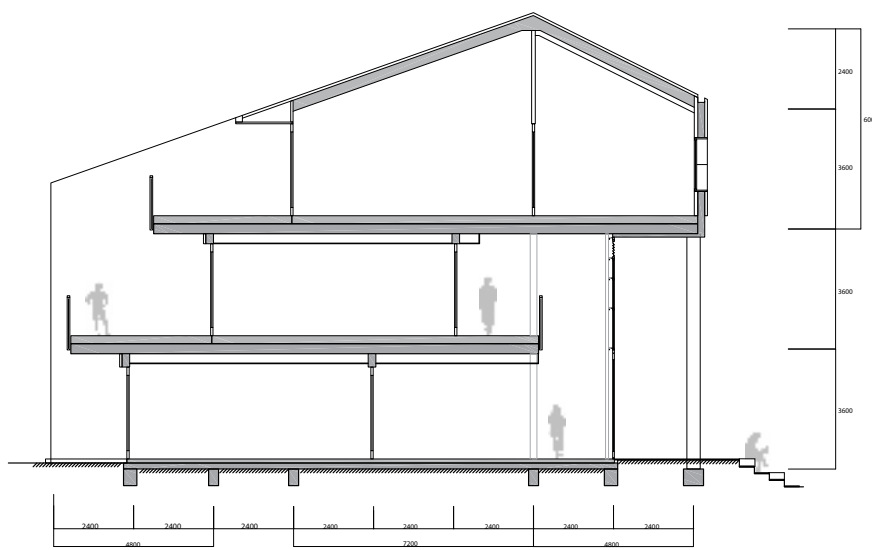
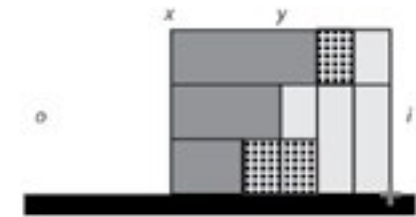
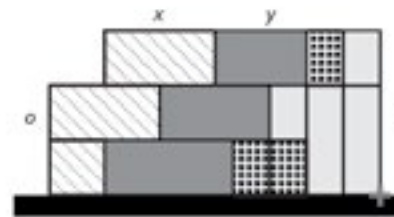
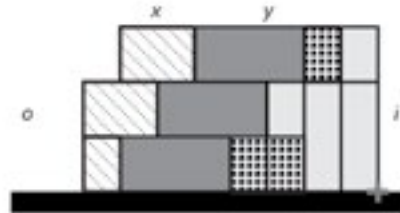
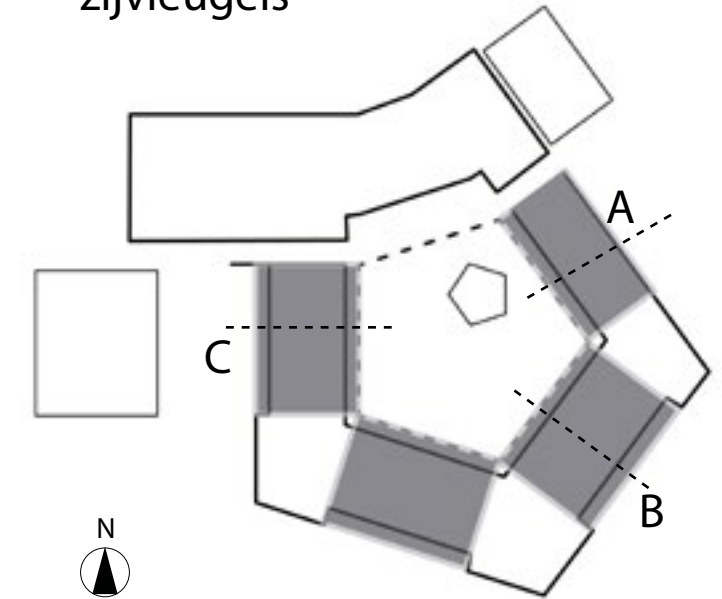

Doorsnede CC' westzijde klaslokalen

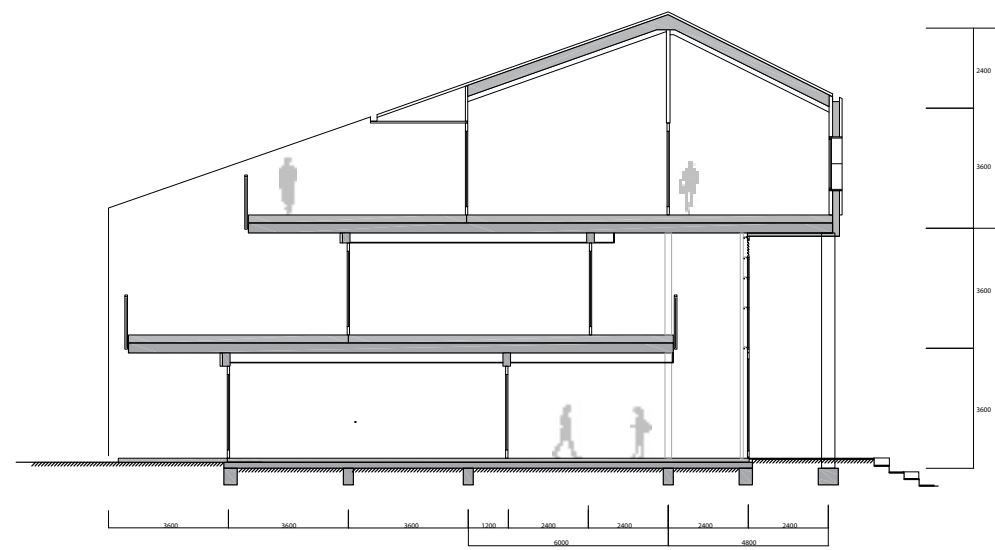

Doorsnede BB' zuidoostzijde klaslokalen

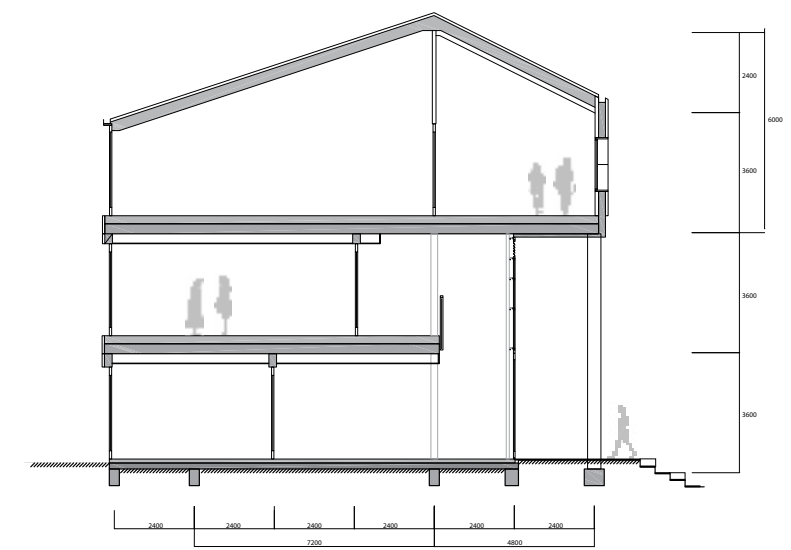

Doorsnede AA' noordoostzijde klaslokalen

Herhaling van het principe

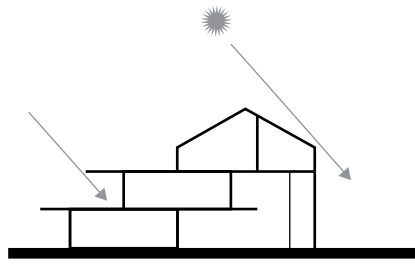

zijvleugels

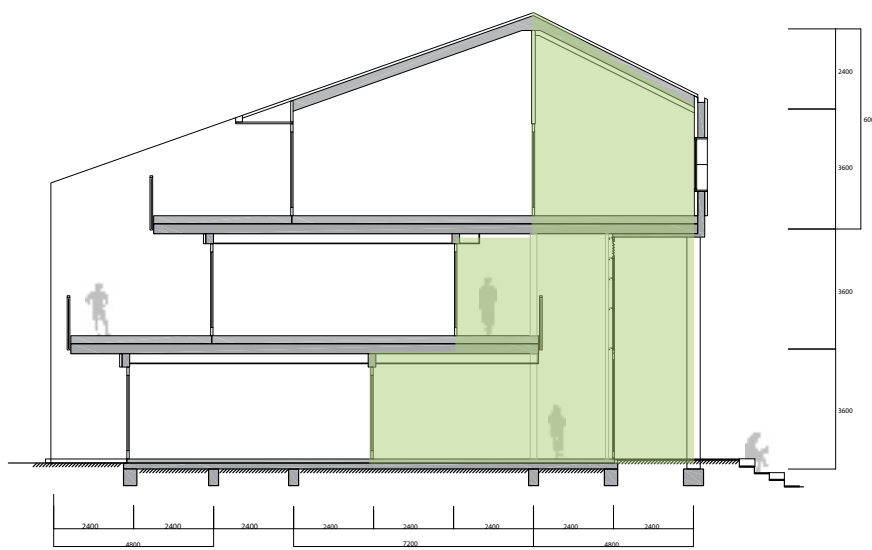
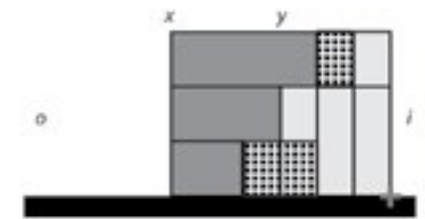
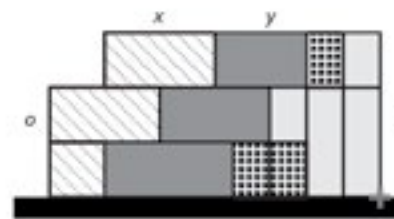
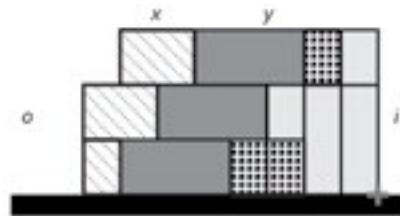
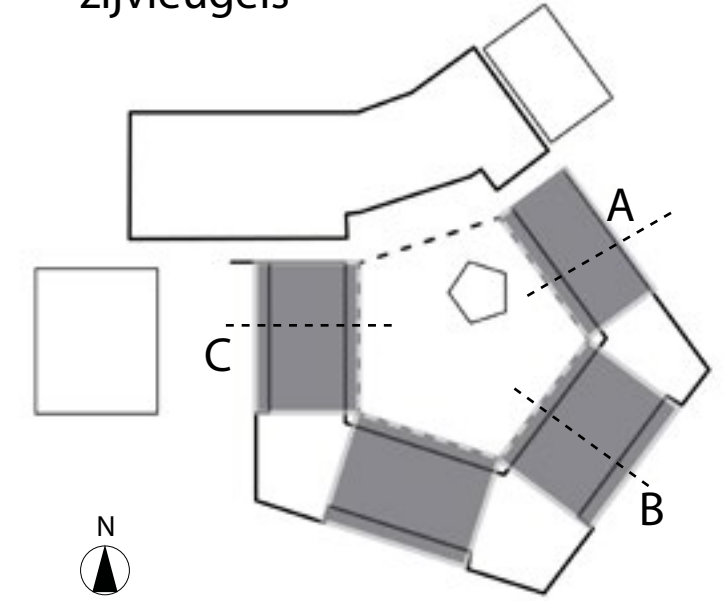

Doorsnede CC' westzijde klaslokalen

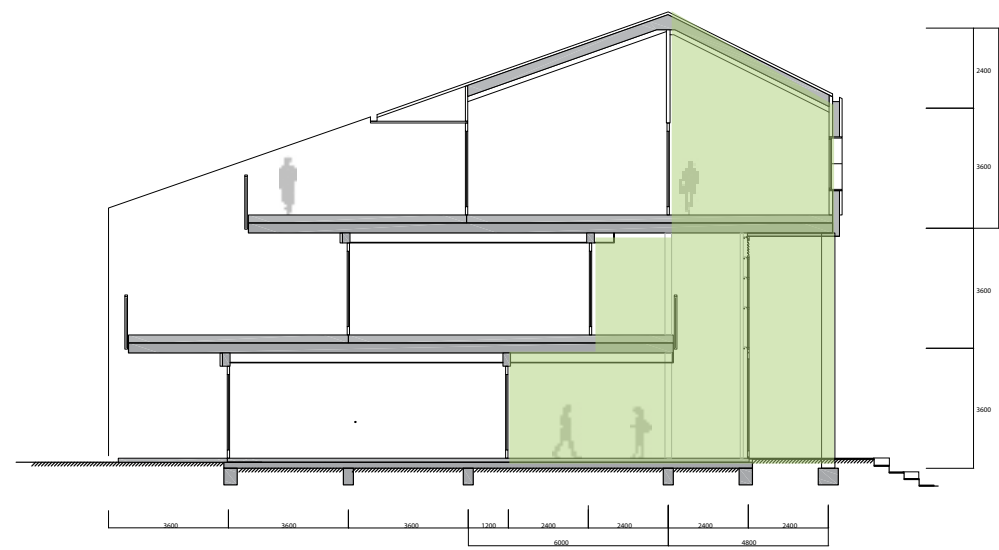

Doorsnede BB' zuidoostzijde klaslokalen

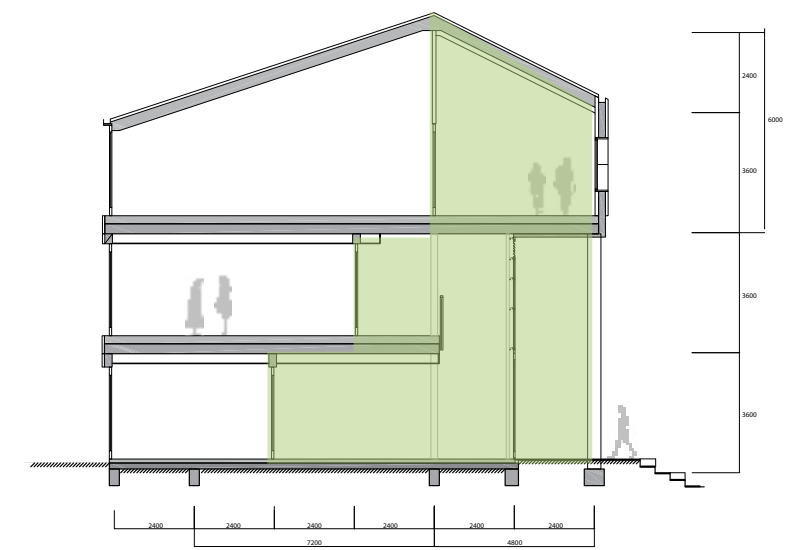

Doorsnede AA' noordoostzijde klaslokalen

Reflectie

1. Metaniveau (structuur)

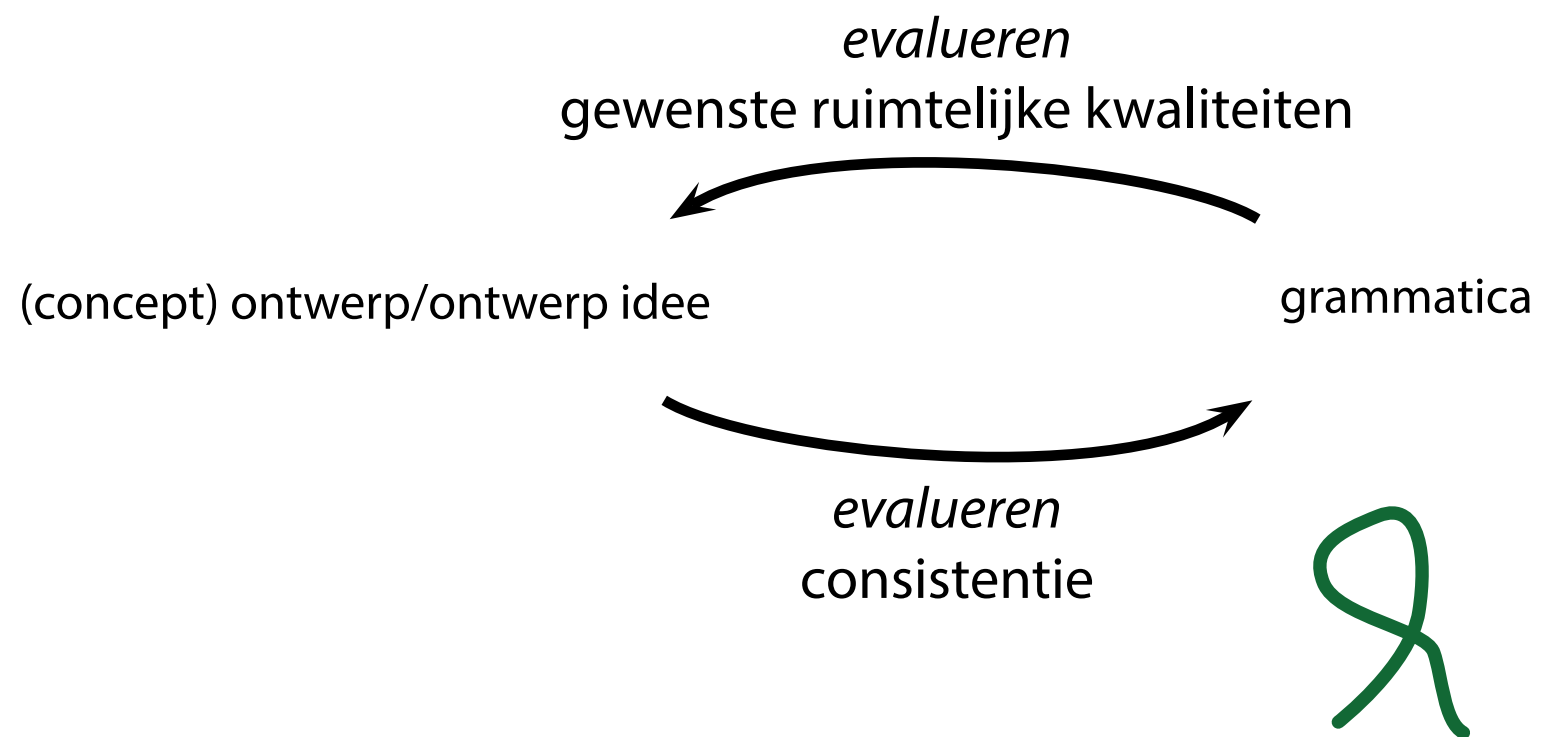
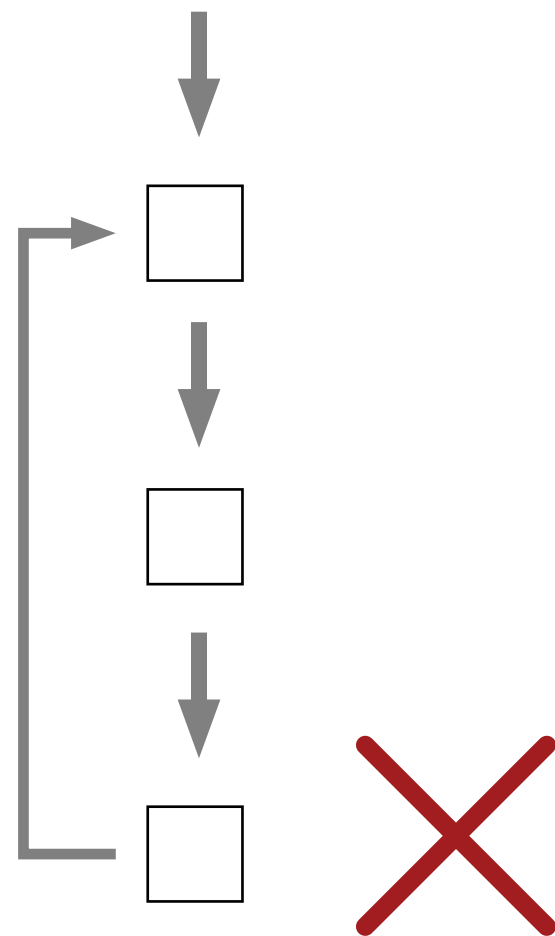

Reflectie

2. Inhoudelijk

Grammatica helpt

- bij het expliciet maken van ontwerpqualiteiten
- bij het maken van consistente (bewuste) ontwerpkeuzes

Risico

- om in een bepaalde schaal te blijven hangen in het ontwerpproces
- starheid *'omdat dat volgens de grammatica klopt...'*

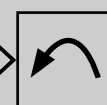
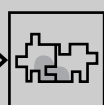
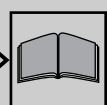

Nog niet genoeg gehad?



Dank u voor uw aandacht