

Modelling relationships between a comfortable indoor environment, perception and performance change

Roelofsen, Paul

DOI

[10.4233/uuid:e7778a5c-3013-40ed-9567-bceaffc57ab9](https://doi.org/10.4233/uuid:e7778a5c-3013-40ed-9567-bceaffc57ab9)

Publication date

2016

Document Version

Final published version

Citation (APA)

Roelofsen, P. (2016). *Modelling relationships between a comfortable indoor environment, perception and performance change*. [Dissertation (TU Delft), Delft University of Technology].
<https://doi.org/10.4233/uuid:e7778a5c-3013-40ed-9567-bceaffc57ab9>

Important note

To cite this publication, please use the final published version (if applicable).
Please check the document version above.

Copyright

Other than for strictly personal use, it is not permitted to download, forward or distribute the text or part of it, without the consent of the author(s) and/or copyright holder(s), unless the work is under an open content license such as Creative Commons.

Takedown policy

Please contact us and provide details if you believe this document breaches copyrights.
We will remove access to the work immediately and investigate your claim.

Modelling relationships between a comfortable indoor environment, perception and performance change

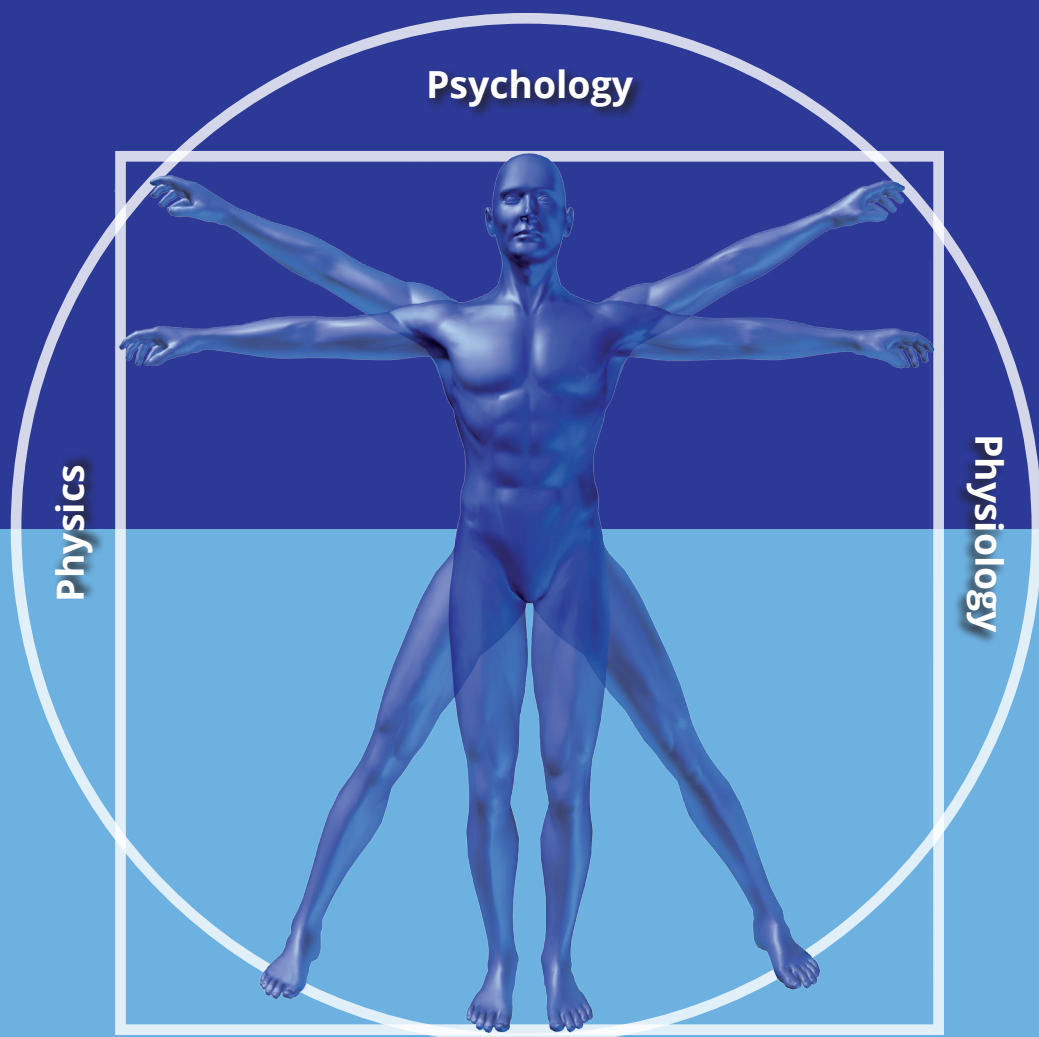

Paul Roelofsen

Modelling relationships between a comfortable indoor environment, perception and performance change

Proefschrift

ter verkrijging van de graad van doctor
aan de Technische Universiteit Delft,
op gezag van de Rector Magnificus, prof. ir. K.C.A.M. Luyben,
voorzitter van het College van Promoties,
in het openbaar te verdedigen op
woensdag 14 december 2016 om 15:00 uur

door

Carel Paul Gerard ROELOFSEN
Ingenieur Bouwkunde
Technische Universiteit Eindhoven, Nederland
Geboren te Amsterdam, Nederland

Dit proefschrift is goedgekeurd door de
promotor: Prof. dr. P. Vink

Samenstelling van de promotiecommissie:

Rector Magnificus,
Prof. dr. P. Vink,

Voorzitter
Technische Universiteit Delft

Onafhankelijke leden:

Prof. dr. H.S.M. Kort,
Prof. ir. W. Zeiler,
Prof. dr. ir. P.M. Bluysen,
Prof. dr. D.V. Keyson,
Prof. ir. P.G. Luscuere,
Dr. M.P. Mobach,

Technische Universiteit Eindhoven
Technische Universiteit Eindhoven
Technische Universiteit Delft
Technische Universiteit Delft
Technische Universiteit Delft
Hanzehogeschool Groningen

This study was sponsored by Grontmij Nederland B.V.



Cover design by Sinds 1961 Grafisch Ontwerp
Printed by Printservice Ede

ISBN: 978-94-91602-75-7
NUR: 955

An electronic version of this dissertation is available at <http://repository.tudelft.nl/>.

Copyright © C.P.G. Roelofsen, Delft 2016

All rights reserved. No part of this publication may be reproduced, stored in a retrieval system, or transmitted in any form or any means, mechanically, photocopying, recording or otherwise, without written permission from the author.

For Jessica, Marjolein and Gijs

Wer immer strebend sich bemüht, den können wir erlösen
(Who ever strives with all his might, that man we can redeem)
(Wie altijd zoekend voorwaarts streeft, mag op verlossing hopen)
J.W. Goethe (1749-1832).

Content

1	Introduction	1
	1.1 Indoor environments a societal problem	1
	1.2 Mission statement and aim	1
	1.3 Key questions	2
	1.4 Research method	2
	1.5 Objective	2
	1.6 S-O-R-model	2
2	Modelling	9
	2.1 The impact of the indoor environment on employee performance	9
	2.2 A computer model to assess the employees performance loss as a function of thermal discomfort or the degree of heat stress	17
	2.3 Improvement of the Stolwijk model by adjusting the model with regard of clothing, thermal sensation and skin temperature	37
	2.4 A proposal for a new model for determining the thermal sensation in a step change transient homogeneous thermal environment	55
3	Indoor Air Quality	77
	3.1 Improvement and use of the carbon dioxide relationship for the evaluation of the perceived air quality depending on the air pollution caused by human bioeffluents	77
	3.2 A new methodology for the evaluation of the perceived air quality depending on the temperature and the humidity of the air and the air pollution caused by human bioeffluents	85
4	Noise	117
	4.1 Improvement and application of the relationship between the performance loss in open office spaces due to noise by speech	117
	4.2 A new methodology for the evaluation of environmental noise based upon the percentage of dissatisfied	127
5	Age	133
	5.1 Design criteria for the indoor environment as a function of age	133
	5.2 The influence of age on thermal sensation and dissatisfied	147
6	Epilogue	163
	6.1 Answering the research questions	163
	6.2 Validity and reliability	165
	6.3 Applicability	167
	6.4 Accessibility	168
	6.5 Main outcomes and food for further research per chapter	168
7	Summary	173
8	Samenvatting	177
9	About the author	181
10	Publications	183
11	Acknowledgement	185
12	References	187
13	Appendix	199
	13.1 Healthy investments in HVAC systems	199
	13.2 Proposed revision to (NEN)-EN-ISO-7730 - Evaluation of draught in surgical operating theatres	211

1 Introduction

1.1 Indoor environments a societal problem

A good indoor environment has value for people and organisations. Nevertheless, the indoor environment is in practice often not as it should be. One reason is that the disciplines touching on this subject are still not able to explain the added value of a good indoor environment enough, with the result that other aspects, related to the housing process, will prevail at the expense of the indoor environment. Already in 1988 a telephone survey conducted by the Building Owners and Managers Association International among 400 facility management and real estate managers in the United States revealed that the indoor environment was regarded as a major problem within the scope of building management, maintenance and design. The aspects that were an issue were the indoor thermal environment, the indoor air quality, lighting and acoustics. The respondents also voiced their expectation that improving the indoor environment would lead to a significant rise in productivity in the organisation (1). An article by Leyten and Kurvers (2) in 2000 contained a summary of the research that underpinned the conclusions drawn above. Extensive scientific research afterwards has also yielded indications suggesting that improving the working environment results in a reduction of the number of complaints and absenteeism and an increase in productivity (3). Today studies and conferences still show that there is room for improvement (4), (5), (6), (7) and that the indoor environmental quality is often still poor, despite policy directives, standards and guidelines (8). This PhD thesis attempts to support finding improvements needed to create a good indoor environment. Much knowledge is available in the literature, but difficult to access for practitioners and it is hard to translate this knowledge into comparison of different options. This PhD thesis tries to fill a gap between theory and practice. An attempt is made to model a large part of the knowledge that is available in such a way that it will become accessible for the professional practice.

1.2 Mission statement and aim

Thus the quality of the indoor environment has influence on health, but also on comfort (8) and performance (7). In the following paragraphs the definitions for indoor environment, health, comfort and performance are defined and will be used in this PhD thesis.

The indoor environment includes all physical, chemical and biological factors in a building that affect the health of the user. The indoor environment is divided into four areas: thermal indoor environment, the indoor air quality, lighting and acoustics. There are many definitions of health. In this PhD health is seen as a state of complete physical, mental and social well-being and not merely the absence of disease or infirmity (WHO definition of health as contained in its constitution; <http://www.who.int/about/definition/en/print.html>). *This WHO definition has been used, because it clearly indicates that health is operationalized in well-being, physical well-being among other things, where this thesis is focused on.* Comfort is defined as the convenience experienced by the end user during or just after experiencing the product of the environment (9). Performance is the product of efficiency and effectiveness (10).

The fact that the indoor environment is assumed to influence health, comfort and performance has consequences for the choice of a certain interior and installation. The relationship between the indoor environment on the one hand and well-being and performance on the other hand and the systems and concepts that influence this relationship offers the possibility to design in such a way that productivity improvements and a comfortable working environment can be created. Improvements in this area could therefore support a financial advantage for the organization. To assess the physical working environment in the context of comfort and performance, followed by an improvement of the indoor environment is an investment in the quality of the work environment, which has a good chance that it will pay off in a better performance,

higher comfort or better health. This final result is a win-win situation for all participants in the housing process and is the mission in this process. The aim of this PhD thesis is to contribute to this mission by the development of new design tools for the professional practice, in the form of mathematical relationships, based on current research and a focus on the so-called HVAC aspects (indoor thermal climate, indoor air quality and acoustics). These relationships are needed to be able to assess the physical working environment in the context of comfort and performance, followed by an improvement of the indoor environment.

1.3 Key questions

The only one who notices the difference is the user of the environment. It is therefore useful to predict the percentage of people that will experience a certain form of the environment with a certain installation as uncomfortable. To contribute to the mission described above studies and models of the effects of interior and system changes on elements are made that are of interest to all stakeholders (11). The key questions in this thesis are:

- Is improvement of current models possible to define more precise the relationship between the physical aspects of the indoor environment and the perception of those aspects?
- Is improvement of current models possible to define more precise the predicted percentage of dissatisfied and the performance change of people?

1.4 Research method

To answer the research questions an attempt is made in this PhD to optimize existing models or data sets in various cases. This could lead to new better grounded (mathematical) models which can predict more realistically the effect on perception and/or the percentage dissatisfied and/or the performance change of people.

1.5 Objective

This thesis is a capita selecta of studies and published papers (see chapter 10), each with the objective of developing a methodology to estimate the perception, the percentage of dissatisfied persons or the change in performance due to the indoor environment. Additionally it is shown what the economic consequences can be in improving the indoor climate, in for instance an office building. As this thesis is not only a theoretical exercise, but should have relevance for building service engineers, architects, building developers and facility managers a condition is that the new mathematical relationships must be practical and easy to implement in existing and for the professional practice available (open source) computer software for the design of buildings and installations. During the studies, partly because of the social changes going on, the realization came that subpopulations (especially young and old) will play an increasingly important role in the field of study. For that reason it was decided to pay attention to this subject and make a first attempt to give some guidelines and tools for evaluating comfort as a function of age in chapter 5, with the awareness that this issue in the remaining time was impossible to investigate completely. As not all problems can be solved in this PhD thesis, suggestions for future research will be given as well.

1.6 S-O-R-model

In understanding how the relationship between an environmental aspect and the response of a human is to that environment, the s-o-r model could be useful and will be described in this paragraph. It is an old model, but still used and very useful in connecting the different chapters in this PhD thesis. According to Watson (12) behaviour, no matter how complex, can be reduced to a simple stimulus – response association. Watson stated that the purpose of psychology is: “to predict, given the stimulus, what reaction will take place; or, given the reaction, state what the situation or stimulus is that has caused the reaction” (12). Later several psychologists added ‘organism’ between stimulus and response, because the human as an or-

ganism is capable of actively deciding whether or not to react to the stimulus or even generate a response without a stimulus. Woodworth was one of the psychologists introducing this Stimulus-Organism-Response (S-O-R) expression (13). Woodworth described that the stimulus can elicit a response, which is dependent on the state of the organism. The “O” (for organism) mediates the relationship between the stimulus (S) and the response (R). This S-O-R model is still often used in for instance business (14) and consumer research (15). He et al. (16) used the model for context based design (see fig 1.6.1). The choice a customer makes is dependent on the situation and the product.

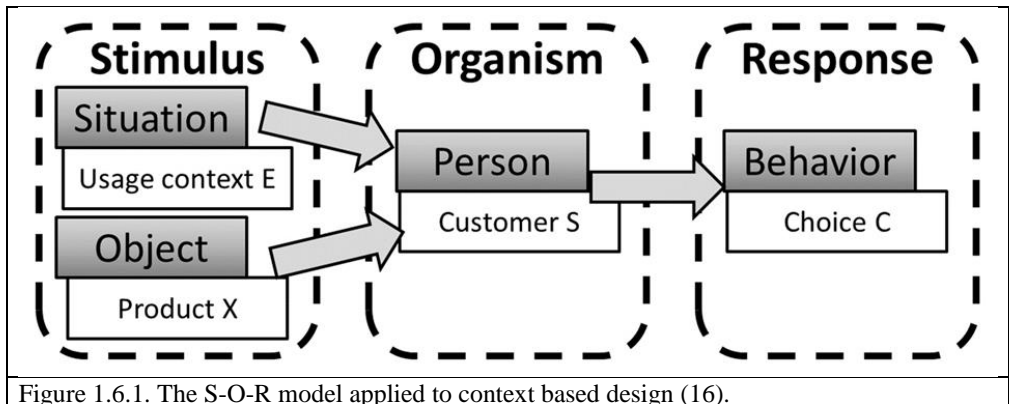

Figure 1.6.1. The S-O-R model applied to context based design (16).

For the effect of an environment on performance and health a similar model can be made (see fig. 1.6.2). The input in the human organism is the task and regarding the environment in a building temperature (thermal), air quality, acoustics and lighting are influencing the human sensors. The organism’s reaction is dependent on the age, the metabolism, the clothing and other individual parameters. The response is a higher or lower performance, physiological effects (e.g. vasoconstriction, goosebumps, shivering, vasodilation, sweating or on the long term physical health effects) and a positive or negative perception or on the long term wellbeing.

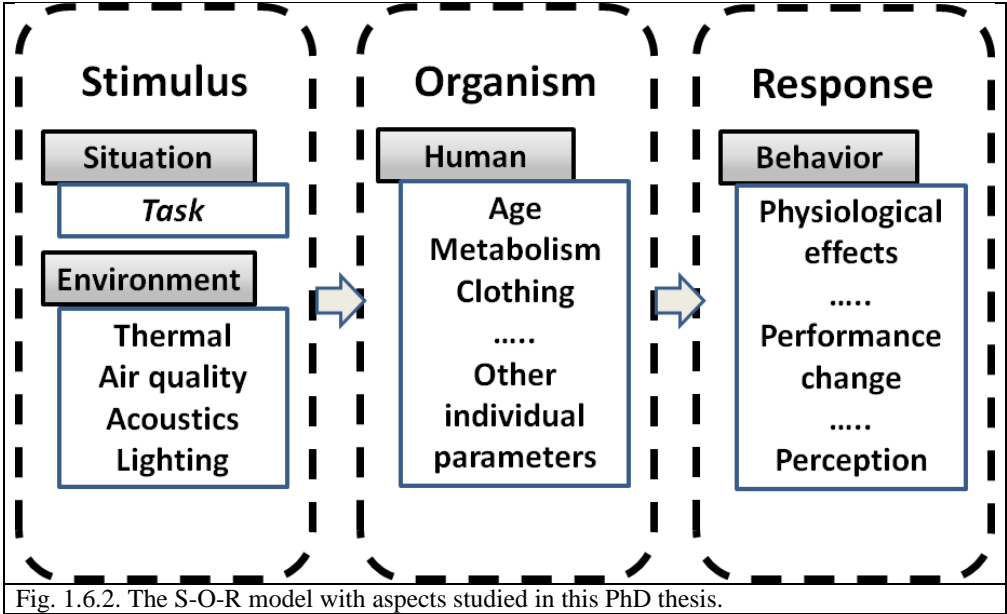

Fig. 1.6.2. The S-O-R model with aspects studied in this PhD thesis.

There are many models on the indoor environment and age available estimating the percentage of people that would feel hindrance, not satisfied or discomfort and perform not well. However, many of the models have room for improvement. Therefore, in the next chapters modelling will be described concerning the improvement of models for thermal environment, air quality, acoustics and taking age into account (chapter 5).

In chapter 2 and 13 the relationship between the thermal environment, perception, dissatisfied and performance change is being modelled (see fig 1.6.3).

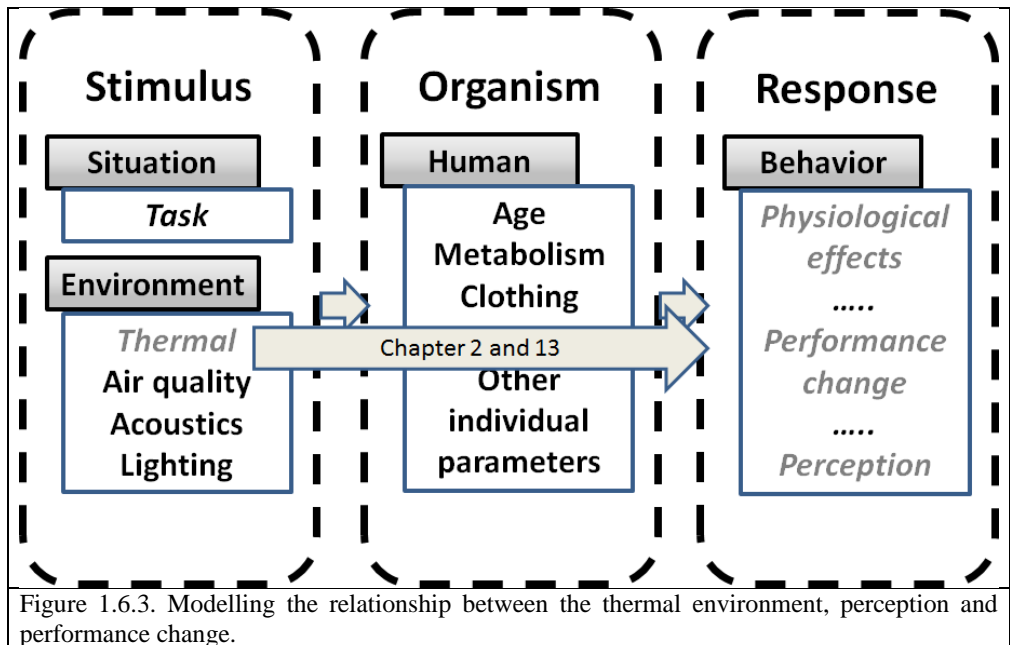

Figure 1.6.3. Modelling the relationship between the thermal environment, perception and performance change.

For instance, the so called GBA-guidelines (a thermal environment with less than 150 weighted temperature transgression hours; an indoor climate according to the Dutch Government Buildings Agency Department (17) and often used for the design of office buildings in the Netherlands) does not show clearly what the gain of a better climate is in terms of performance of the work force. In this PhD thesis (appendix 13.1) an attempt has been made to improve the thermal evaluation by adding performance predictions, which makes it possible to estimate the return on investment of an improvement of a climate installation system with regard of the thermal comfort level. A computer program has been assembled, based on the Gagge model (19) and the research of Havenith (20), to evaluate the influence of individual characteristics (viz. age and fitness) on the thermal comfort of a person (chapter 2.1). Also several performance loss models as a function of thermal sensation or WBGT, with different scopes (e.g. office work and construction work), are implemented in the aforementioned computer program. Another example is the Stolwijk model (14), which is an advanced mathematical thermophysiological human model, still used by the industry and research community (18), to evaluate dynamic thermal environments. The original Stolwijk model however is not taking into account the type of clothing, thermal sensation, percentage of dissatisfied, individual characteristics and performance loss due to wrong climates. In this PhD thesis (chapter 2.3) a computer program of the Stolwijk model is assembled and the model is adjusted by including some of the aforementioned aspects for future use. Chapter 2.4 describes a proposal for a new model for determining the thermal sensation in a step change transient homogeneous thermal environment that is more accurate and has a larger scope than the DTS-model of Fiala et al. (19).

A suggestion is to standardize the classic and known experiments in the literature in future, on the basis of which reliable equations are to derive, so that for each dynamic human thermophysiological model equivalent to or more accurate than the Stolwijk model, the appropriate coefficients are to determine on the basis of the here proposed TTS-model.

Appendix 13.2 focuses on a combination of new relationships with regard of predicted percentage of dissatisfied due to draught. With this combination of new relationships, programmed in a CFD-model, the scope of the here assembled model is much larger than the current draught model in NEN-EN-ISO-7730 and can even be used to design a ventilation system in an operating theatre, as is showed in this chapter.

In chapter 3 the relationship between air pollution by human bioeffluents, perception, dissatisfied and performance change is being modelled (see fig 1.6.4).

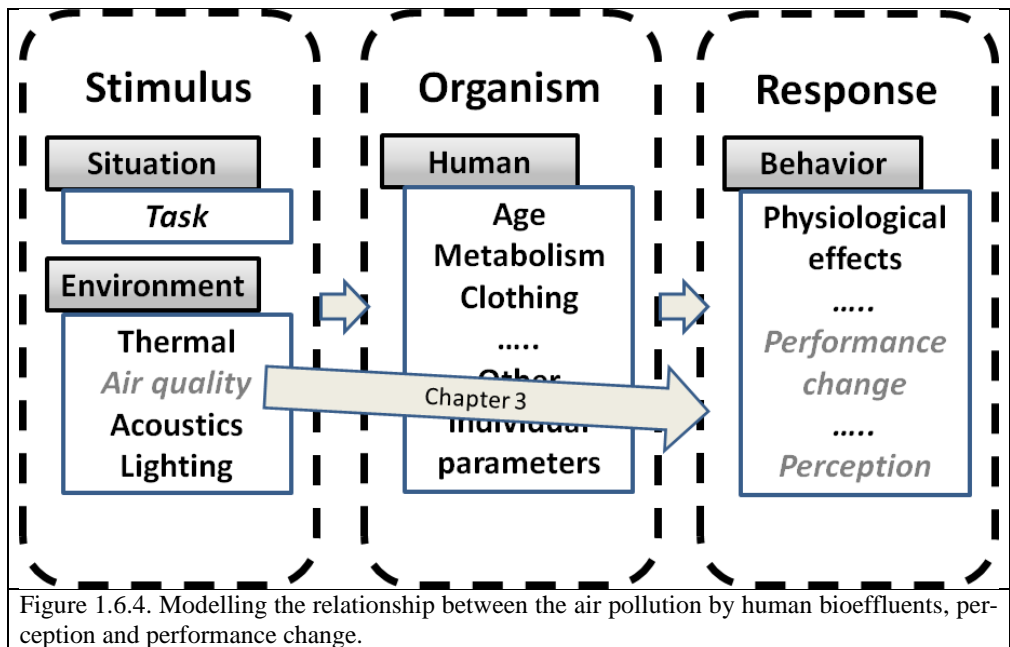

Figure 1.6.4. Modelling the relationship between the air pollution by human bioeffluents, perception and performance change.

Chapter 3.1 of this thesis introduces an equation which shows that the percentage of dissatisfied due the perceived indoor air quality is a function of the CO₂-concentration difference between the air in the occupied space, polluted by human bioeffluents, and the fresh air supplied, as well as the amount of fresh air supplied to each person. The equation is valid for a metabolism equal to or larger than 1,1 met, unlike the equation, based on the CO₂ concentration difference, mentioned in NPR-CR-1752 (17), which is only valid voor a metabolism of 1,1 met. Also, different researchers found an influence of the air enthalpy on the perceived air quality (20) which is not part of for instance the current olf-decipoI-method of Fanger (21) and the evaluation methods described in NPR-CR-1752 (22) and NEN-EN-15251 (23). An attempt has been made to develop a methodology which includes the level of freshness of the air and the predicted percentage of dissatisfied depending of the temperature and humidity of the air and the amount of air pollution by human bioeffluents (chapter 3.2). In chapter 3.2 also an evaluation of the improved model has been carried out to see wether empirically the prediction can be verified.

In chapter 4 the relationship between noise by speech, perception and performance change as well as environmental noise and dissatisfied is being modelled (see fig 1.6.5).

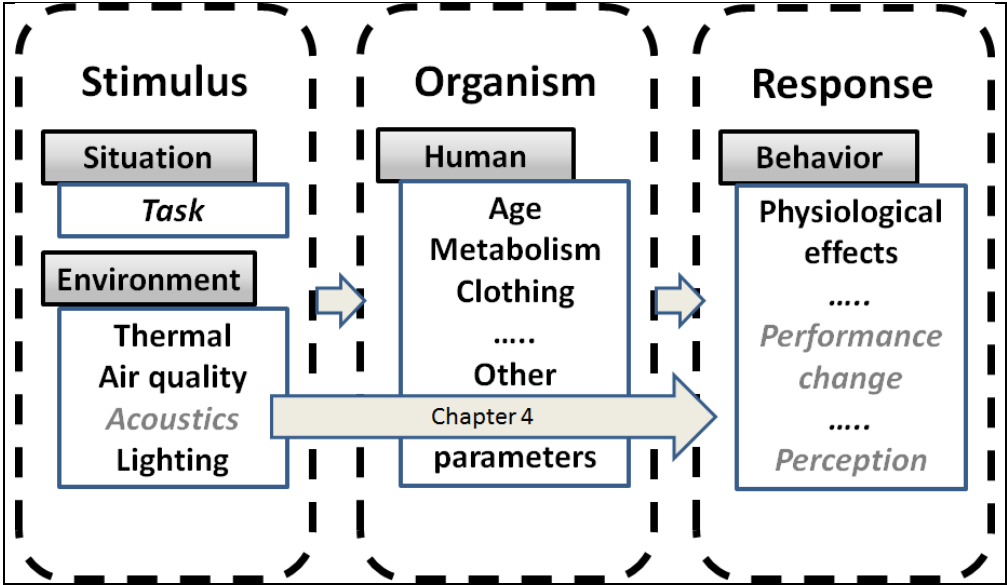

Figure 1.6.5. Modelling the relationship between noise by speech, perception and performance change as well as environmental noise and dissatisfied.

In chapter 5 the relationship between the indoor environmental aspects, age and perception is being modelled (see fig 1.6.6).

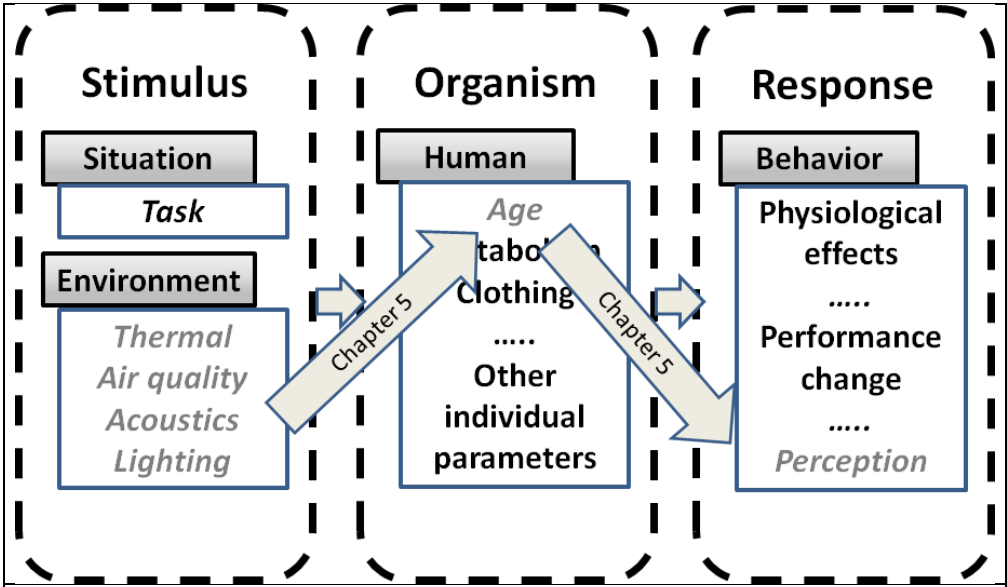

Figure 1.6.6. Modelling the relationship between the indoor environmental aspects, age and perception.

Also, specific attention for age is still missing in many indoor quality models. Therefore, a first translation into a guideline for the indoor environment, including acoustics, light, air quality and the indoor thermal climate, is made as a function of age (chapter 5).

By exploring whether better models and design tools can be put together the research questions can be answered whether improvement of current models makes it possible to define more precise physical aspects of the indoor environment that influence discomfort, satisfaction and human performance.

In the next chapters the model improvements are described. In chapter 6 a reflection on these chapters is given and the question is answered whether a more precise modelling is possible.

2 Modelling

2.1 The impact of the indoor environment on employee performance

An increase in performance is expressed in a directly quantifiable reduction of absenteeism, such as a reduction in the number of employees that leave work too early or take long lunch breaks. The improvement in performance can however also be the result of an increase in the quantity and the quality of the production during the period that employees are actively working. A comprehensive effort in order to reach a reliable instrumental translation of existing knowledge can be found in (24) and (25).

2.1.1 Absenteeism

Research into people's satisfaction with the quality of the indoor environment in 61 Dutch office buildings (some 7000 respondents) reveals that the employees questioned are absent on 2.5 days a year owing to complaints related to the indoor environment. This represents a quarter of the total average absenteeism of 10 days a year (absenteeism percentage 5% of 2000 workable days) per employee (26).

2.1.2 Hindrance

As well as absenteeism, the hindrance aspect can also cause loss of productivity. Employees are present at the workplace but work less hard. The effect of quality improvement on the indoor environment yields an increase in performance varying from 5 to 15% (27), (28), (29).

2.1.3 Factors affecting productivity

As well as the working environment, there are also factors outside of the working environment that can have a positive or negative effect on a person's performance (30), (31) (see figure 2.1.1). These factors cover areas such as domestic problems, personal relationships or the excessive consumption of food or drink, which affect a person's performance at work.

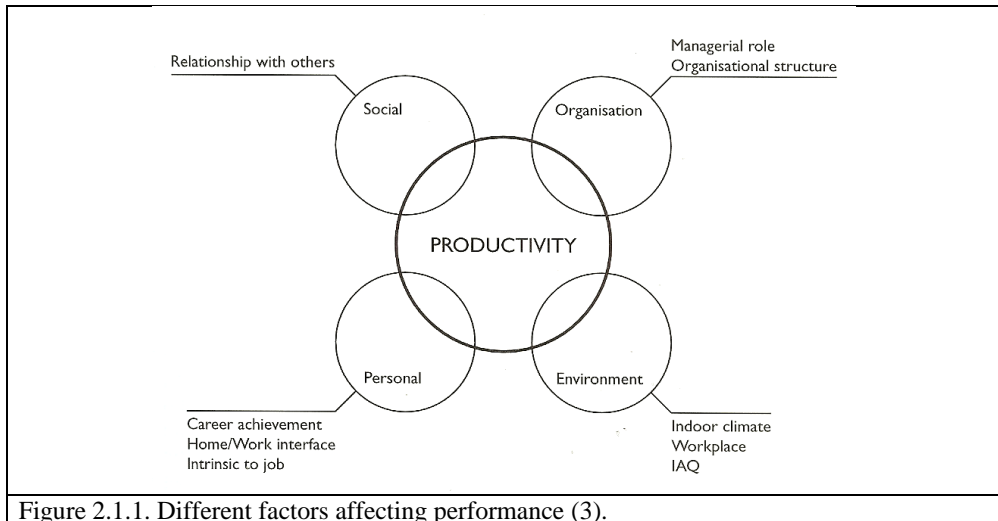

Figure 2.1.1. Different factors affecting performance (3).

These factors are however beyond the control of the organisation. Conversely, the working environment is the direct responsibility of the management.

Aspects such as job stress or job dissatisfaction also come under the responsibility of the management. Job dissatisfaction is related (among other things) to the question of motivation. This is a crucially significant factor regarding performance. It concerns basic motives, rewards, both tangible and intangible, and personality variables. Assuming that a clear and significant level of motivation is present and guaranteed, what is the relative role of the indoor environment on performance change and productivity change? (28).

2.1.4 Interaction

Research is being conducted at Reading University in England into the effect of the working environment, management style, job satisfaction, job stress and personal factors on people's productivity and health (30), (27), (32). A pilot research project held among 170 people in six office buildings reveals that there is a clear relationship between job stress, job dissatisfaction and the indoor environment. Furthermore, a productivity increase of 10% was observed following improvements to the indoor environment.

Using multiple linear regression analysis based on research results the researchers made a equation for the Worker Evaluation of Productivity (WEP) according to a 9-point scale, with dissatisfaction with the indoor environment, job stress and job dissatisfaction as variables according to a 7-point scale.

The equation is as follows:

$$\text{WEP} = 6.739 - 0.419.E - 0.164.JD - 0.048.JS$$

Where:

- WEP = Worker Evaluation of Productivity
- E = Dissatisfaction with the indoor environment
- JD = Job dissatisfaction
- JS = Job stress.

It is clear from this equation that the indoor environment has a relatively substantial effect on productivity in relation to the other parameters. It is also clear that employees regard the indoor environment more critically in proportion to the extent to which the other parameters are comparatively unsatisfactory.

WEP can be regarded as a measure of what the employee himself thinks, regardless of whether that opinion is correct. If employees feel that the physical and psychological conditions in the office affect their productivity, that view is important because it likely too affects other areas of the work. Researchers regard the WEP as a suitable yardstick for productivity (28).

The interaction of the organizational, psychosocial, personal and indoor environmental quality effects (see figure 2.1.1) are still not thoroughly investigated. The same is the case with the interaction of the indoor environmental parameters itself and the influence on the percentage of dissatisfied and performance loss of people. The literature with regard of those relationships is scarce and still premature (33), (34), (35), (36), (37), (38). Most studies that investigated the influence of the indoor environmental quality on dissatisfied or performance focused solely on the thermal environment or indoor air quality or acoustics.

Since the (improvement of the) relationships/models to estimate effects in this thesis are based on already conducted studies, the amount of data available was not considered sufficient to create relationships/models which could estimate the effects with regard to other aspects than

solely the thermal environment or indoor air quality or acoustics. The interest in this thesis was given to studies on the mathematical relationship between thermal sensation and performance, dissatisfied and performance, Carbon dioxide concentration and performance and speech intelligibility and performance.

2.1.5 The thermal indoor environment

The thermal environment has a considerable effect on performance and is even measurable within the comfort zone (31). Unlike sound and light, the thermal environment affects all workers, regardless of the nature of their activities (39).

2.1.6 Indoor air quality

Research results have demonstrated that the indoor air quality has a significant effect on the productivity of employees, both in positive and in negative terms (40). In for instance a normal office with good climate control it was possible to produce two different air qualities. The percentage of dissatisfied employees was 15% (Category A according to NPR-CR 1752 (22)) and 23% respectively (roughly corresponding to Category B). The same test subjects worked for 4,5 consecutive hours on simulated office work. Their productivity proved to be 6,5% higher with air of the highest quality, and they also displayed fewer symptoms of Sick Building Syndrome (40). Later studies confirm the positive effect of good air quality on productivity. These research results strongly justify providing employees with good air quality in the future (41).

2.1.7 The auditory indoor environment

It is known that sound levels above a critical limit can cause hearing damage. This limit must of course be respected. Nevertheless in the case of for instance open offices (42) or sound levels in combination with temperature (33) research results assuredly show that noise prove to be of influence on performance (34).

2.1.8 Level of control

Most users' complaints are about the temperature and draught and to a lesser extent about noise, lighting and air pollution. This holds especially true if the temperature and ventilation are only controlled centrally without the users being able to exert any control. Aspects such as noise and lighting, however, are often mainly influenced by changes at a level in the building that can be influenced by the user (e.g. the internal lay-out, the work station set-ups that are partly determined by the users). There are indications that if users are able to exercise greater control over the indoor working environment, there is an improvement in performance, involvement in the work and morale. This implies an increase in productivity within the organisation (figure 2.1.2) (30), (43), (44). A recent study executed at the Eindhoven University of Technology showed that office workers that say to have a high amount of control over their indoor climate perceive to be significantly more productive than those that say to have a low amount of control. The quantitative effect of improving a no control situation towards a full control situation was estimated to be at least 6% (45).

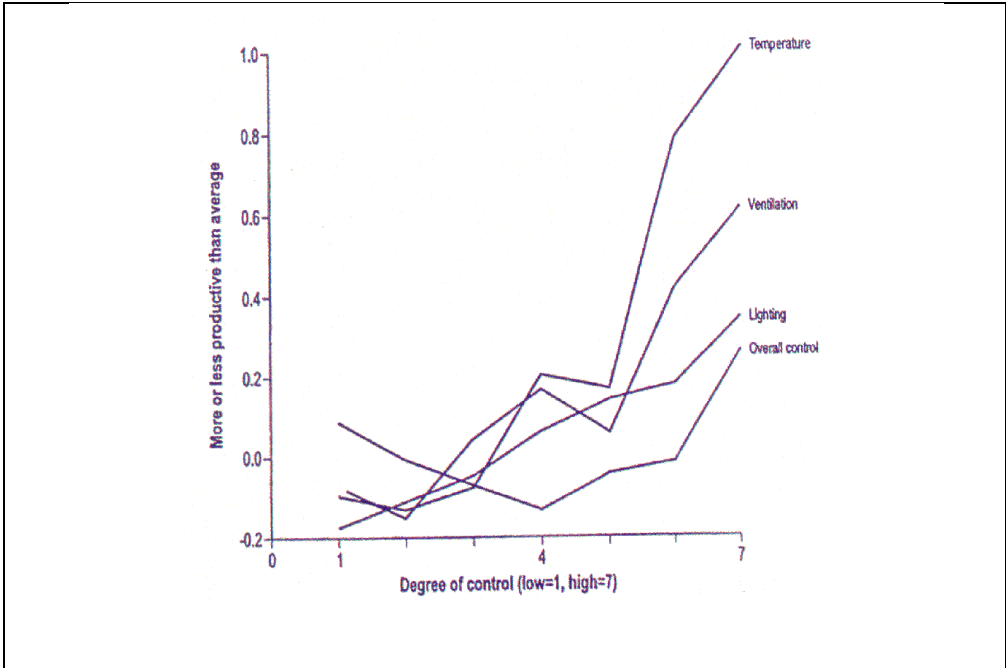

Figure 2.1.2. - Relationship between self-reports of productivity and levels of control (30).

2.1.9 Overview selected experiments

Table 2.1.1 shows an overview of the in the literature selected experiments investigating the mathematical relationship between the indoor environmental aspects and the performance change. The below mentioned experiments are chosen from the literature because they concern studies in one explicitly sought mathematical relationships between indoor environment quality factors and the performance in carrying out certain tasks. For clarity, the most relevant aspects of these experiments are summarized in Table 2.1.1. and the subsequent summaries.

Table 2.1.1. Overview of selected experiments.

First author	Ref.	Environmental aspect	Experiment	IEQ factor
Roelofsen	(46)	Thermal	Laboratory	PMV
Mohamed et al.	(47)	Thermal	Laboratory	PMV
Mohamed et al.	(48)	Thermal	Field	PMV
Kosonen et al.	(49)	Thermal	Laboratory	PMV
Jensen et al.	(50)	Thermal	Field	PMV
Lan et al.	(51)	Thermal	Laboratory	PMV
Zhao et al.	(52)	Thermal	Laboratory	WBGT
Wargocki et al.	(40)	Air quality	Laboratory	PD
Jacobs et al.	(53)	Air quality	Laboratory/Field	CO ₂ / PD
Hongisto	(42)	Noise	Laboratory/Field	STI

Roelofsen (46)

Berglund et al. (54) used the human thermophysiological model of Gagge (55) to relate the performance loss with the discomfort-scale. This relationship predicted the extent the productivity of normally dressed office workers might vary depending on the indoor temperature.

Their analysis is based on the assumption that thermal stress perceived by the worker as thermal discomfort is the best indicator of performance loss. Roelofen (46) used the Gagge model (55) further and converted the Discomfort-values to two other standardized thermal comfort indices, namely the Predicted Mean Vote (PMV) and the Predicted Percentage of Dissatisfied (PPD) (56), enabling the model to be used with various combinations of thermal factors. The performance loss equation as derived by Roelofsen is applied in a study, as shown in appendix 13.1.

Mohamed et al. (47)

Mohamed et al. (47) report on a research study that focused on predicting the loss of construction workers' productivity due to thermal environment variations. The paper utilizes a statistical polynomial regression analysis to establish a relationship between productivity and the predicted mean vote (PMV) thermal comfort index. In doing so, it builds upon a substantial amount of data reported in the literature regarding construction productivity and thermal environment. A set of equations reflecting the nature of the construction task being performed as well as the thermal environment are proposed to predict the degree of change in workers' productivity, according to a change in the thermal environment. The paper also reports on an experimental investigation undertaken to validate the developed equations. Validation results indicate that the developed equations can predict productivity with a reasonable level of accuracy. Furthermore, they show that the workers' productivity decreases as the PMV index moves away from the optimum range for all the observed tasks (47).

Mohamed et al. (48)

Mohamed et al. (48) provide a critical summary of previous attempts to model the productivity-thermal environment relationship in construction. The paper builds upon the wealth of reported productivity data under a wide spectrum of thermal environment conditions and proposes a model for estimating productivity for three physically different construction tasks. The accuracy of the developed model estimates is then examined against data collected from four construction sites in the Northeast of Thailand (48).

Kosonen et al. (49)

The theoretical study of Kosonen et al. (49) reports on the assessment of productivity loss in air-conditioned office buildings using the PMV approach and makes use of Wyon's reviews [D.P. Wyon, P.O. Fanger, B.W. Olesen, C.J.K. Pedersen, The mental performance of subjects clothed for comfort at two different air temperatures, *Ergonomics* 18 (1975) 358–374; D.P. Wyon, Individual microclimate control: required range, probable benefits and current feasibility, in: *Proceedings of Indoor Air '96*, Institute of Public Health, Tokyo, 1996; D.P. Wyon, Indoor environmental effects on productivity. IAQ 96 Paths to better building environments/Keynote address. Y. Kevin. Atlanta, ASHRAE, pp. 5–15] as the basis to compare and to relate how the productivity loss could be minimised through improved thermal comfort design criteria. The finding shows that task-related performance is significantly correlated with the human perception of thermal environment that in turn is dependent on temperatures. Different combinations of thermal criteria (air velocity, clo, metabolic, etc.) can lead to similar PMV value and the PMV equation is useful to predict productivity loss that is due to the rate of change in thermal conditions. The study also highlights the issues that remain to be resolved in future research (49).

Jensen et al. (50)

A Bayesian Network approach has been developed that can compare different building designs by estimating the effects of the thermal indoor environment on the mental performance of office workers. A part of this network is based on the compilation of subjective thermal sensation data and the associated objective thermal measurements from 12,000 office occupants from different parts of the world. A Performance Index (P) is introduced that can be used to compare directly the different building designs and furthermore to assess the total economic consequences of the indoor climate with a specific building design. In this paper, focus will be on the effects of temperature on mental performance and not on other indoor climate factors. A total economic comparison of six different building designs, four located in northern Europe and two in Los Angeles, USA, was performed. The results indicate that investments in improved indoor thermal conditions can be justified economically in most cases. The Bayesian Network provides a reliable platform using probabilities for modelling the complexity while estimating the effect of indoor climate factors on human beings, due to the different ways in which humans are affected by the indoor climate (50).

Lan et al. (51)

The effects on human performance of elevated temperature causing thermal discomfort were investigated in the study of Lan et al. (51). Recruited subjects performed neurobehavioural tests examining different component skills, and addition and typing tasks that were used to replicate office work. The results show that thermal discomfort caused by elevated air temperature had a negative effect on performance. A quantitative relationship was established between thermal sensation votes and task performance. It can be used for economic calculations pertaining to building design and operation when occupant productivity is considered. The relationship indicates that optimum performance can be achieved slightly below neutral, while thermal discomfort (feeling too warm or too cold) leads to reduced performance. Consequently, it makes sense to set the PMV limits in workplaces in the range between -0.5 and 0 instead of between -0.5 and 0.5 as stipulated in the present standards. This advice is also given earlier by Roelofsen (46) and Clements-Croome (30).

Zhao et al. (52)

In this paper human body experiments and statistics analysis with the software of EXCEL were applied to establish a heat tolerance time model and a productivity model in hot and humid environment. Firstly, a chamber stimulating hot and humid environment was built and the experiment on heat tolerance and productivity in this chamber was completed. Heat tolerance time and productivity in different environments were tested with the change of air temperature and humidity in the environment chamber. According to the experiment results, regressive formulas for heat tolerance time changing with thermal environment parameter (WBGT) in three conditions of physical labour intensity were provided by statistics methods respectively. On this basis, the function of productivity changing with heat tolerance time and thermal environment parameter (WBGT) in three conditions of physical labour intensity using multiple linear regression analysis tool of EXCEL were obtained finally. F-test was also applied to verify the significance of all the established regression equations. The result shows that the effect of curve regression is significant and the regression function gives important statistic meaning and practical value to work time determination and productivity prediction in hot and humid environment (52).

Wargoeki et al. (40)

Perceived air quality, Sick Building Syndrome (SBS) symptoms and productivity were studied in an existing office in which the air pollution level could be modified by introducing or

removing a pollution source. This reversible intervention allowed the space to be classified as either non-low-polluting or low-polluting, as specified in the European design criteria for the indoor environment CEN CR 1752 (1998). The pollution source was a 20-year-old used carpet which was introduced on a rack behind a screen so that it was invisible to the occupants. Five groups of six female subjects each were exposed to the conditions in the office twice, once with the pollution source present and once with the pollution source absent, each exposure being 265 minutes in the afternoon, one group at a time. They assessed the perceived air quality and SBS-symptoms while performing simulated office work. The subject-rated acceptability of the perceived air quality in the office corresponded to 22% dissatisfied when the pollution source was present, and to 15% dissatisfied when the pollution source was absent. In the former condition there was a significantly increased prevalence of headaches ($P=0,04$) and significantly lower levels of reported effort ($P=0,02$) during the text typing and calculation tasks, both of which required a sustained level of concentration. In the text typing task, subjects worked significantly more slowly when the pollution source was present in the office ($P=0,003$), typing 6,5% less text than when the pollution source was absent from the office. Reducing the pollution load on indoor air proved to be an effective means of improving the comfort, health and productivity of building occupants (40).

Jacobs et al. (53)

In this study, the results of research by TNO (57), Wargocki et al. (58) and Shaughnessy et al. (59) are used to derive two relationships, namely a function between learning performance and the amount of fresh air into a classroom and a function between the learning performance and CO_2 -concentration in the classroom. The graphical representation of the aforementioned relationships suggest a strong performance fall below $4 \text{ dm}^3/\text{s}$ per person (in a steady state condition about 1500 ppm CO_2). Above that the learning performance at first increases still relatively strongly. Above $8 \text{ dm}^3/\text{s}$ per person (in a steady state condition about 1000 ppm CO_2) the performance gain decreases. Given the limited measurement data at higher ventilation rates no conclusion can be drawn on the ventilation level where no effect occurs. There are two corrections carried out in order to show the relationships graphically. Firstly, the learning performance in both relationships are relative, in order to allow comparison of the different tests. The performance at $4 \text{ dm}^3/\text{s}$ is taken as 100 percent, as in two out of three studies, this was a measuring point. As an exception to this in the study of Wargocki et al. a measuring point of $4.7 \text{ dm}^3/\text{s}$ per person was present. Based on the assumption of a linear relationship there is made a correction for this. Secondly, the concentration of CO_2 is converted into a ventilation rate. It is assumed that the CO_2 -production of a pupil is $17 \text{ dm}^3/\text{h}$. Possibly because no equilibrium is reached, the ventilation rate can be overestimated. The combination of the results of the three studies suggests a relationship, whereby a small ventilation rate has a considerable negative effect on the learning performance. A doubling of the ventilation rate in relation to the Dutch Building Regulations Act results in an improvement of the learning performance by about 10 percentage points. At higher ventilation rates the learning improvement do not end up increasing. At which ventilation rate it ceases to have effect on learning performance improvement, is not yet known (53).

Hongisto (42)

Speech is the most distracting sound in (open-plan) offices. Several laboratory studies have shown that speech impairs the performance of, for example, reading and short-term memory. It is not the sound level of speech that determines its distracting power but its intelligibility, which can be physically determined by measuring the Speech Transmission Index (STI). The aim of this study was to develop a mathematical model that predicts how much the performance is reduced due to speech of varying intelligibility. The model was based on the litera-

ture according to which performance decrements have been 4–45% depending on the task. The best performance occurs when speech is absent ($STI=0.0$), and the strongest performance decrement occurs when speech is perfectly heard ($STI=1.0$). The shape of the performance vs. STI between 0.0 and 1.0 was adopted from the general speech intelligibility theory. The performance starts to decrease when STI exceeds 0.2. Highest performance decrease is reached already when STI exceeds 0.60 (42). The research of Haapakangas et al. (60) conforms that the speech transmission index is a good predictor of both performance loss and subjective disturbance. The results from the research of Haapakangas et al. (60) and Haka et al. (61) provide support for the model of Hongisto. The drop in performance occurred between 'good open office' condition ($STI \leq 0.35$) and 'poor open office' condition ($STI \geq 0.65$). This is in line with Hongisto's model that predicts that performance starts to deteriorate when STI exceeds 0.30. Hongisto used the only few published studies that have investigated the effect of speech on cognitive performance with varying levels of speech intelligibility. Therefore more research is needed on the effect of speech intelligibility on task performance in order to improve the proposed model and encourage investments in acoustic improvements.

An overview, comparison and modelling of the first seven studies is presented in chapter 2.2. The studies of Wargocki et al. and Jacobs et al. are used for modelling in chapter 3. The study of Hongisto is used for modelling in chapter 4.1.

The above mentioned experiments are used to model this part of the knowledge in the literature in such a way that it will become available for the professional practice.

2.2 A computer model to assess the employees performance loss as a function of thermal discomfort or the degree of heat stress

ABSTRACT. This chapter presents an overview of different research and researchers' attempts to derive a mathematical relationship between the performance loss and the thermal (dis)comfort of working people, expressed in the mean thermal sensation.

The goal of this chapter and research is to present a single computer model and manageable design tool for a variety of disciplines i.e., mechanical engineering, building services and facility management; disciplines that participate in the design of the indoor environment of new or existing buildings and the improvement of working conditions in the workplace.

The single computer model proposed in this chapter is assembled using a validated mathematical human thermophysiological model (62) and a validated mathematical Wet Bulb Globe Temperature Index model (63), in combination with various mathematical performance (loss) models, based on comfort indices and heat stress indices. *In addition to office work also other activities are to consider with the model.*

Although not perfect, the model is especially usable in the situation of comparative studies. For instance in the early stages of the design process, the computer model assists in making better/the right (design) decisions regarding the thermal aspects of the indoor environment, whether or not in combination with validated building simulation models.

The use of a dynamic thermophysiological model, in combination with the aforementioned models, enables the evaluation of the thermal influence of every architectural and building service and related adjustments for people and organizations. The use of a combination of models, as shown above, makes it possible to negotiate solutions and better balance investments with regards for profits and workable hours.

Keywords

Thermophysiological model, thermal discomfort, heat stress, WBGT, performance, productivity.

2.2.1 Introduction

Heat and heat stress can be a major problem in work environments. Although technological techniques have made it possible to remote control certain industrial processes (e.g. from a conditioned cabin), there are still many people obliged to work in warm or hot environments.

Heat stress can occur in environments with high air temperature (e.g. the summer period), high thermal radiation (e.g. foundries, steel mills, glass- & ceramic industry, stone and cement industry & factories, furnaces etc.) or in environments where there is heavy physical work or where protective clothing is necessary. Heat stress can also occur outside a building (e.g. in the construction industry, in agriculture, in the world of sport, etc).

When exposed to heat stressing conditions the person's thermalregulatory system adjusts physiological mechanisms such as skin blood flow, and sweating to stabilize or reduce body heat gains and internal body temperatures. These and related adjustments may increase heart rate, skin temperature and moisture, fatigue and possible dehydration. Under extreme conditions, the physical effort may reach a size that it affects health. Working in a hot (and humid) environment can not only harm a person's health but will definitely affect the work performance.

While biologists, medical researchers and experts in the field of thermal physiology gathered a large amount of knowledge in the last decennia, the knowledge is still inadequate for improving the indoor environment in buildings. The reason is that the studies and calculations are not suitable for the fields of study and are not deemed manageable by the relevant disciplines (62).

The goal of this chapter and research is to present a practical tool for a variety of disciplines i.e., mechanical engineering, building services and facility management; disciplines that participate in the design of the indoor environment of new or existing buildings and the improvement of working conditions in the workplace.

The influence of the thermal environment on health, the (dis)comfort and the performance of a person in certain activities are determined by the combination of a mathematical thermo-physiological model and several performance (loss) models. This is important for the thermal aspect (design) decisions in the built environment, especially in the case of comparative studies. For this reason, this chapter presents a computer model, as a combination of the aforementioned usable models, and a literature review of this subject within the field of mechanical engineering, building services and facility management.

The mathematical models developed over the years for the calculation of different (dis)comfort indices and the empirical and analytical heat stress indices are included as well as a number of mathematical models used for the calculation of the performance loss of a person, under different thermal conditions, and the maximum allowable exposure time (AET) for certain activities. The computer model is based on a dynamic thermophysiological human model, with a broad scope, to evaluate thermal conditions for humans on the performance aspect, combined with discomfort ($-2.0 \leq PMV \leq 2.0$) or heat stress ($PMV > 2.0$).

This chapter focuses particularly on the warm and hot side of the comfort zone and a number of performance (loss) models, suitable for discomfort and heat stress as well as the calculation of the required wet bulb globe temperature, all usable in combination with a mathematical

thermophysiological model. In addition, the chosen thermophysiological human model is briefly explained, because it is already extensively described in the literature.

2.2.2 Thermophysiological human model

According to the Gagge model (55), a computer model has been assembled for the study of the thermal conditions on the performance aspect, combined with the degree of discomfort or the degree of heat stress.

The model of Gagge consists of two concentric layers or compartments, in which the inner layer represents the core and outer layer represents the skin. The two compartments exchange heat with each other by conduction and blood circulation. All of the energy of metabolism is assumed to occur in the core. The physiological mechanisms of skin blood flow, sweating, shivering etc. for thermoregulation are controlled in the Gagge model by deviations in compartment temperatures from their setpoint temperatures. The setpoints are associated with the compartment's temperature at rest in a state of thermal neutrality.

The regulatory mechanisms alter heat flows between the compartments and also with the environment to reduce the deviations from the setpoints. Continuous energy balances on the compartments enable the calculation of the rate of compartment temperature change. The rates of temperature change are integrated to determine a compartment's temperature. As a result of current conditions, activities and heat flows, core and skin temperatures change with time and can be determined together with the related physiological mechanisms of heart rate, sweating, water loss, skin moisture and heat flows etc. The computer program based on the Gagge model (55) predicts in addition to physiological variables, the sensations of body temperature (e.g. PMV), feelings of discomfort (e.g. Disc) and the percentage of dissatisfied (PPD) as well as performance (change).

The range for the model is validated by the intervals for the following personal parameters and environmental parameters (62), (64), (65):

- Metabolism : 58 – 350 [W/m²]
- Intrinsic clothing value : 0 – 3 [Clo]
- Air velocity : 0.1 – 5 [m/s]
- Relative air humidity : 30 – 100 [%]
- Air temperature : 10 – 45 [°C]
- Mean radiant temperature : 10 – 45 [°C]
- Exposition time : 0,5 – 4 hours
- Skin fold thickness : 5 – 22 mm
- Body length : 1.69 m (± 10%)
- Body weight : 70 kg (± 20%).

The Gagge model is used for research in the industry and research community, by among others the Biophysics and Biomedical Modeling Division US Army Research Institute of Environmental Medicine in the USA (66), the RWTH Aachen University (67), the Kobe university (65) and the university of Tokyo in Japan (68).

An example of the output of the computer model is shown in figure 2.2.1 for the situation:

- Metabolism : 70 W/m²
- Intrinsic clothing value : 0.7 clo
- Air velocity : 0,15 m/s

- Relative air humidity : 60%
- Operative temperature : 30 - 40°C
- Exposition time : 1 hour

Thermofysiologisch mens-model van Prof. Dr. A. P. Gagge.

MR	Tclo	ETA	Lenkte	Gewicht	Adu	RV	Vrel.	Baro	Time	CHC	TTSK	TTCR	CSW	CDIL	CSTR	HPD	Eveff
[W/m2]	[CLO]	[-]	[m]	[kg]	[m/s]	[m/s]	[ata]	[hr]	[W/(m2.K)]	[sC]	[sC]	[sC]	[gr/(hr.K)]	1/(hr.K)]	[(hr/1.K)]	[mm]	[-]
70.00	0.70	0.00	1.69	70.00	1.81	60.0	0.15	1	1.00	3.77	33.7	36.8	170	200	0.50	16.82	0.85

Tl	Tr	CHR	SET	PMW	PPD	PPDM	DISC	DISCC	DISC	Teens	HSI	HS	Ereq	AET				
[sC]	[sC]	[W/(m2.K)]	[sC]	[-]	[%]	[%]	[-]	[-]	[-]	[-]	[%]	[%]	[B/min]	[W/m2]	[min]			
30.0	30.0	4.45Uncomfortable	warm.	31.5	2.02	77	78	1.55	0.00	1.75	1.72	44	91	41.7	0	
31.0	31.0	4.49Uncomfortable	warm.	32.6	2.30	88	87	1.79	0.00	2.06	1.94	49	94	45.9	0	
32.0	32.0	4.52Uncomfortable	warm.	33.7	2.59	95	92	2.06	0.00	2.39	2.15	56	96	50.1	0	
33.0	33.0	4.56Uncomfortable	warm.	34.8	2.88	98	96	2.36	0.00	2.77	2.37	63	100	54.4	0	
34.0	34.0	4.59Uncomfortable	hot.	36.0	3.17	100	98	2.71	0.00	3.19	2.58	71	103	58.7	0	
35.0	35.0	4.63Uncomfortable	hot.	37.1	3.47	100	99	3.10	0.00	3.67	2.80	81	107	63.2	0	
36.0	36.0	4.66Uncomfortable	hot.	38.2	3.77	100	99	3.57	0.00	4.24	3.03	92	112	67.7	0	
37.0	37.0	4.70Very	uncomfortable	hot.	39.3	4.07	100	100	3.95	0.00	4.70	3.36	103	118	72.0	1021
38.0	38.0	4.74Very	uncomfortable	hot.	40.3	4.34	100	100	3.95	0.00	4.70	4.02	111	121	75.2	318
39.0	39.0	4.78Very	uncomfortable	hot.	41.3	4.61	100	100	3.95	0.00	4.70	4.09	123	127	78.9	163
40.0	40.0	4.82Limited	tolerance.	42.3	4.89	100	100	4.92	0.00	4.70	4.19	139	133	82.8	105	

Tl	Tdew	To	Tcl	Tsk	Tcr	Tm	Tml	Tmh	Tskm	Tsf	Praw	Pwet	Pwett	Cres	DRY	RM	ALPHA	Ppcl	PPHq	STO	SVPD	PMVSET	PPDS	PPDSM
[sC]	[sC]	[sC]	[sC]	[sC]	[sC]	[sC]	[sC]	[sC]	[sC]	[sC]	[sC]	[sC]	[sC]	[sC]	[sC]	[sC]	[sC]	[sC]	[sC]	[sC]	[sC]	[sC]	[sC]	[sC]
30.0	21.4	30.0	32.5	35.1	36.9	36.8	36.5	37.1	35.2	33.7	0.33	0.37	0.00	0.4	23.9	70.0	0.07	0.48	2546	30.3	2706	2.01	77	78
31.0	22.3	31.0	33.1	35.2	36.9	36.8	36.5	37.1	35.4	33.7	0.38	0.42	0.00	0.3	20.0	70.0	0.07	0.48	2696	31.2	2852	2.28	88	86
32.0	23.3	32.0	33.7	35.4	36.9	36.8	36.5	37.1	35.6	33.7	0.44	0.47	0.00	0.2	16.1	70.0	0.06	0.48	2853	32.2	3004	2.57	95	92
33.0	24.2	33.0	34.2	35.5	36.9	36.9	36.5	37.1	35.7	33.7	0.50	0.53	0.00	0.1	12.1	70.0	0.06	0.48	3019	33.1	3163	2.87	98	96
34.0	25.1	34.0	34.8	35.7	37.0	36.9	36.5	37.1	35.8	33.7	0.58	0.60	0.00	0.0	8.0	70.0	0.06	0.48	3192	34.1	3331	3.18	100	98
35.0	26.1	35.0	35.4	35.8	37.0	36.9	36.5	37.1	36.0	33.7	0.66	0.68	0.00	-0.1	3.9	70.0	0.06	0.48	3374	35.0	3506	3.48	100	99
36.0	27.0	36.0	36.0	35.9	37.0	37.0	36.5	37.1	36.1	33.7	0.76	0.77	0.00	-0.2	-0.3	70.0	0.06	0.49	3565	36.0	3689	3.79	100	99
37.0	27.9	37.0	36.6	36.1	37.0	37.0	36.5	37.1	36.3	33.7	0.84	0.85	0.00	-0.3	-4.2	70.0	0.05	0.49	3766	37.0	3883	4.08	100	100
38.0	28.9	38.0	37.3	36.5	37.2	37.3	36.5	37.1	36.7	33.7	0.84	0.85	0.00	-0.4	-7.1	70.0	0.05	0.49	3976	37.9	4089	4.27	100	100
39.0	29.8	39.0	38.0	36.8	37.3	37.3	36.5	37.1	37.0	33.7	0.84	0.85	0.00	-0.5	-10.5	70.0	0.05	0.49	4196	38.9	4303	4.47	100	100
40.0	30.7	40.0	38.6	37.1	37.5	37.5	36.5	37.1	37.3	33.7	0.84	0.85	0.00	-0.6	-14.0	70.0	0.05	0.49	4426	39.8	4526	4.70	100	100

Tl	STORC	STORE	SKBP	REGSW	Esk	Ersw	Edif	Eres	Edrip	Drip	Emax	VSK	RMSK	Tacc	Prod	Perfd	Pdic	ET	WBOT	Thtt	Pwbtg
[sC/hr]	[W/m2]	[W/m2]	[l/(m2.hr)]	[gr/(hr.m2)]	[W/m2]	[W/m2]	[W/m2]	[W/m2]	[W/m2]	[gr/(m2.hr)]	[W/m2]	[W/m2]	[W/m2]	[W/m2]	[W/m2]	[W/m2]	[W/m2]	[W/m2]	[W/m2]	[hr]	[%]
30.0	0.00	0.13	26.21	54.48	41.57	37.05	4.52	4.01	0.00	0.00	95.58	3692	0.65	67	76	23.7	21.4	30.9	25.9	0.00	0.0
31.0	0.00	0.17	29.15	61.23	45.69	41.64	4.05	3.83	0.00	0.00	92.82	3952	0.69	58	73	26.6	24.3	32.0	26.8	0.00	0.0
32.0	0.01	0.22	32.43	68.10	49.87	46.31	3.56	3.64	0.00	0.00	89.75	4220	0.73	48	71	29.4	27.2	33.1	27.7	0.00	0.0
33.0	0.01	0.28	36.08	75.11	54.10	51.07	3.03	3.44	0.00	0.00	86.33	4498	0.78	36	68	32.2	30.2	34.3	28.6	0.00	0.0
34.0	0.01	0.35	40.07	82.25	58.40	55.93	2.47	3.23	0.00	0.00	82.54	4785	0.82	23	65	35.5	33.4	35.4	29.5	0.00	0.0
35.0	0.01	0.43	44.40	89.54	62.77	60.89	1.88	3.01	0.00	0.00	78.37	5082	0.86	9	60	40.4	37.3	36.6	30.4	0.00	0.0
36.0	0.01	0.51	49.05	96.98	67.20	65.94	1.25	2.78	0.00	0.00	73.81	5389	0.91	0	50	49.8	42.3	37.8	31.3	0.00	0.0
37.0	0.06	2.41	56.30	108.48	69.58	68.79	0.78	2.54	4.98	7.32	69.58	5649	0.94	0	32	68.3	47.2	38.9	32.2	0.00	0.0
38.0	0.20	7.70	78.83	141.82	67.49	66.73	0.76	2.28	29.71	43.69	67.49	5796	0.95	0	0	100.0	47.2	40.0	33.2	0.00	0.0
39.0	0.40	15.00	90.00	184.06	63.93	63.21	0.72	2.02	61.96	91.11	63.93	5915	0.95	0	0	100.0	47.2	41.0	34.1	3.48	89.4
40.0	0.62	23.20	90.00	235.73	59.68	59.01	0.67	1.74	101.29	148.95	59.68	6027	0.96	0	0	100.0	47.2	42.1	35.0	3.04	83.0

DISC [+/- 0.5] :

- 3 = Cold.
- 2 = Cool.
- 1 = Slightly cool.
- 0 = Comfortable and pleasant.
- 1 = Slightly uncomfortable but acceptable.
- 2 = Uncomfortable and unpleasant.
- 3 = Very uncomfortable.
- 4 = Limited tolerance.
- 5 = Intolerable.

Figure 2.2.1. Output of the assembled computer model, according to the Gagge model (this study).

Finally, individual characteristics, other than metabolism, clothing resistance, body weight and body length act as an important parameter in thermal regulation and need to be introduced into the Gagge model/computer model as an improvement along with age, sex, body fat, fitness, and so on. Modifying the Gagge model/computer model with individual characteristics opens up the possibility of evaluating the differences between subpopulations (e.g. elderly and non-elderly). These additional aspects however will not be addressed in this chapter.

2.2.3 Performance loss as a function of discomfort

Different researchers have made an attempt to derive a mathematical relationship between the performance loss and the thermal (dis)comfort of working people, expressed in a category scale of individual whole body thermal sensation. The following section provides an overview of the relationships that currently exist, with a mutual comparison of previously performed research on performance loss as a function of the indoor temperature.

2.2.4 Performance loss as a function of the indoor temperature

Seppanen, Fisk & Faulkner (69) have collected, for the office situation, the results of several experiments on performance loss as a function of the indoor temperature. In Figure 2.2.2 the

collected results of those experiments are displayed graphically, including the results of a later research of Tawada et al. (70). The thick printed line in the figure represents the relationship that Seppanen, Fisk & Faulkner (69) derived for the warm side of the comfort zone based on the abovementioned experiments (excl. Tawada et al. (70)). According to this relationship (Seppanen et al. (69)) the performance loss per °C above 25 ° is 2%.

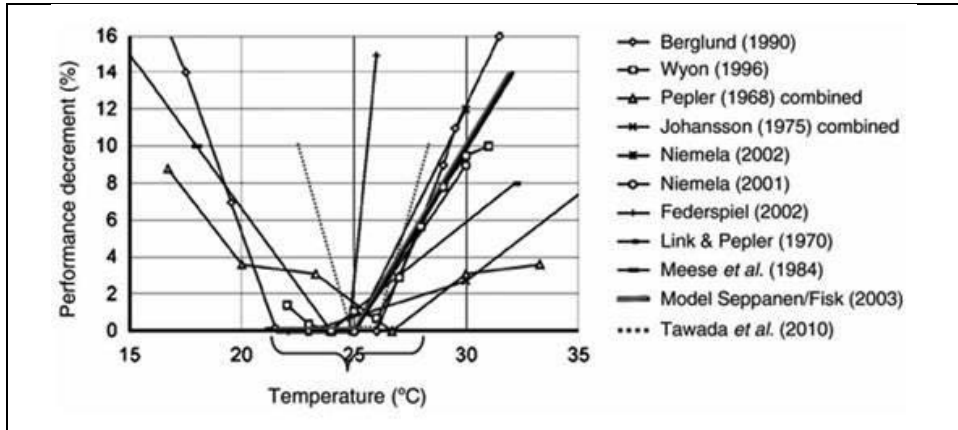

Figure 2.2.2. Summary of the studies on the effect of room temperature on decrement of performances and productivity [Seppanen et al. (69)]. Sources adapted from Seppanen et al. (69), with the addition of Tawada et al. (70) (71).

A survey conducted by the Loughborough University of Technology (72) shows the relationship Berglund et al. (54) derived (see Berglund 1990 in Figure 2.2.2) as reasonably in line with other research results (viz. Boyce and Griffiths (73), Wyon et. al (74), Hettinger (75), Wyatt (76), Allen & Fischer (77) and Lorsch & Abdou (78)) and suitable for comparative studies on the performance change relating with to the thermal indoor environment in offices.

The results of Berglund et al. (54) in combination with the Gagge-model (55) match indeed reasonably well with the research results of Hettinger (75) on the performance level of office staff for a wide range of air temperatures and relative humidity on the warm side of the comfort zone (see Figure 2.2.3). In the results of Hettinger besides temperature also the humidity of the air is considered, as is not the case in the other performance loss studies.

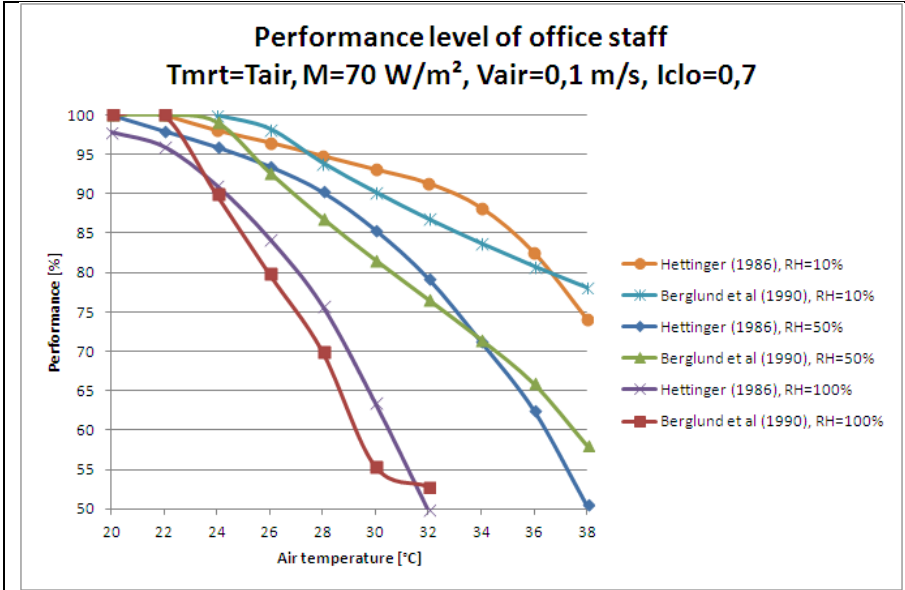

Figure 2.2.3. Comparison of the results of Berglund et al. (54) with the results of Hettinger (75).

Berglund et al. (54) used the human thermophysiological model of Gagge (55) to relate the performance loss with the Disc-scale. This relationship predicted the extent the productivity, of normally dressed office workers, might vary, depending on the indoor temperature. Their analysis is based on the assumption that thermal stress, perceived by the worker as thermal discomfort, is the best indicator of performance loss. Roelofsen (46) used the Gagge model (55) further and converted the Disc-values to two other standardized thermal comfort indices, namely the Predicted Mean Vote (PMV) and the Predicted Percentage of Dissatisfied (PPD) (56), enabling the model to be used with various combinations of thermal factors.

2.2.5 Performance loss as a function of the mean thermal sensation

A relationship between the performance loss and the thermal discomfort is in line with methods used worldwide to assess the indoor thermal climate according to International Standard Organization’s ISO 7730 [e.g. (56)] and based on the predicted mean vote (PMV).

2.2.6 The research of Roelofsen

Based on the research of Berglund et al. (54), the research of Roelofsen (46) derived, the following formula:

- $P = b_0 + b_1 \cdot PMV + b_2 \cdot PMV^2 + b_3 \cdot PMV^3 + b_4 \cdot PMV^4 + b_5 \cdot PMV^5 + b_6 \cdot PMV^6$

Herein is:

- P = the performance loss [%]; $P \geq 0$
- b_0 t/m b_5 = regression coefficient [-]; See Table 2.2.1.
- PMV = predicted mean vote, according to ISO-7730 (56).

Table 2.2.1. Regression coefficients are shown in the equation of the performance loss.

Regression coefficients	Cold side of comfort zone	Warm side of comfort zone
b_0	1.280	-0.154
b_1	15.995	3.882
b_2	31.507	25.176
b_3	11.755	-26.641
b_4	1.474	13.110
b_5	0	-3.130
b_6	0	0.293

2.2.7 The research of Mohamed & Korb

In 2002 Mohamed & Korb (47) found relationships for the performance loss of light, medium and heavy construction work as a function of the mean thermal sensation, based on 200 datasets of research conducted by several other scientists (79), (80), (81), (82), (83), namely:

- $PI = 102 - 0.80 \cdot PMV - 1.84 \cdot PMV^2$
- $Pm = 102 + 1.19 \cdot PMV - 2.17 \cdot PMV^2$
- $Ph = 83 + 21.64 \cdot PMV - 9.53 \cdot PMV^2 + 0.91 \cdot PMV^3$

Herein is:

- PI = the productivity of light construction work (Metabolism < 130 W/m²) [%]
- Pm = the productivity of mean construction work (130 ≤ Metabolism ≤ 190 W/m²) [%]
- Ph = the productivity of heavy construction work (190 < Metabolism ≤ 350 W/m²) [%]
- PI, Pm en $Ph \leq 100$ [%]
- PMV = predicted mean vote, according to ISO-7730 (56).

The relationships are validated based on experiments with 15 healthy male volunteers, between the ages of 24 and 36 years old, located in a climate chamber, and for the following activities.

Light construction work

- Attaching paper to the wall (Metabolism=110 W/m²)

Medium construction work

- Laying vinyl floor tiles (Metabolism=170 W/m²)

Heavy construction work

- Pushing a wheelbarrow (Metabolism=230 W/m²) and shoveling sand (Metabolism=250 W/m²).

In 2003, Mohamed & Korb (48) compared to their previous publications on this subject (47), published updated relationships for the performance loss of construction work as a function of the mean thermal sensation, namely:

- $PI = 99.91 - 0.796 \cdot PMV - 1.843 \cdot PMV^2$
- $Pm = 99.81 + 1.30 \cdot PMV - 2.27 \cdot PMV^2$
- $Ph = 83.952 + 15.09 \cdot PMV - 4.76 \cdot PMV^2$

Herein is:

- PI = the productivity of light construction work (Metabolism < 130 W/m²) [%]
- Pm = the productivity of mean construction work (130 ≤ Metabolism ≤ 190 W/m²) [%]
- Ph = the productivity of heavy construction work (190 < Metabolism ≤ 350 W/m²) [%]

- $PI, Pm \text{ en } Ph \leq 100$ [%]
- $PMV =$ predicted mean vote, according to ISO-7730 (56).

The relationships are validated, with data collected at four construction sites in the Northeast of Thailand, for the following activities.

Light construction work

- Painting (Metabolism=120 W/m²)

Medium construction work

- Brick-laying (Metabolism=190 W/m²)

Heavy construction work

- Excavation (Metabolism=350 W/m²).

In both publications of Mohamed & Korb (47) and (48) productivity is calculated on the basis of the model of Fanger (84), according to ISO 7730 (56). The model of Fanger, according to ISO 7730, is validated for:

- $-2 < \text{Predicted Mean Vote (PMV)} < 2$
- $46 \text{ W/m}^2 < \text{Metabolism} < 232 \text{ W/m}^2$
- $0 \text{ clo} < \text{Intrinsic clothing resistance} < 2 \text{ clo}$
- $10^\circ\text{C} < \text{Air temperature} < 30^\circ\text{C}$
- $10^\circ\text{C} < \text{Mean radiant temperature} < 40^\circ\text{C}$
- $0 \text{ m/s} < \text{Mean air velocity} < 1 \text{ m/s}$
- $0 \text{ Pa} < \text{Water vapor pressure} < 2700 \text{ Pa}$.

The relationships validated by Mohamed & Korb (47); (48) are noticeable because conditions fall outside the above limits (viz. metabolism higher than 232 W/m², and air temperatures less than 10 °C and higher than 40 °C and PMV-values greater than 2).

The adjusted relationships derived by Mohamed & Korb (48) for the performance loss of construction work are displayed graphically in Figure 2.2.4.

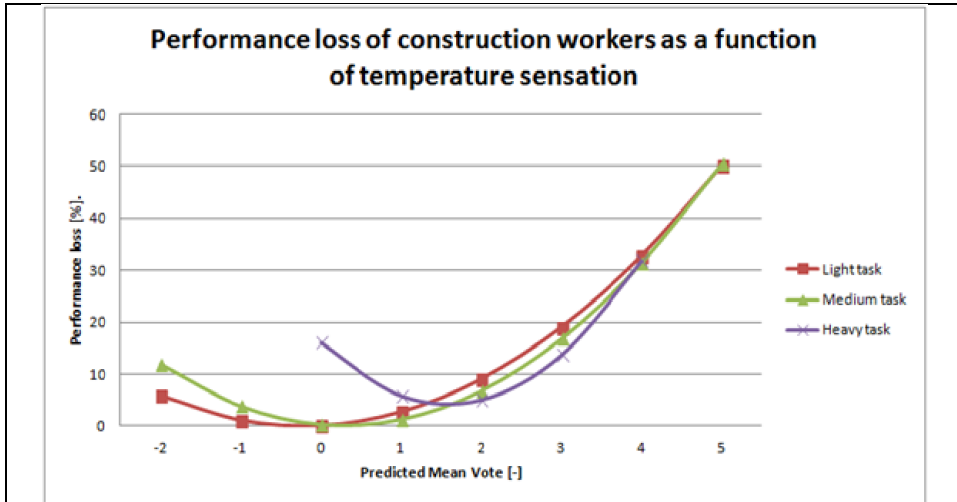

Figure 2.2.4. Performance loss of construction work (48).

2.2.8 The research of Kosonen & Tan

Kosonen & Tan (49) published two relationships for the performance loss of typing and thinking as a function of the mean thermal sensation for the warm side of the comfort zone (ergo, $PMV \geq 0$), based on the research of Wyon et al. (85), a study with 16 females and 16 male participants aged between 18-25 years, and Wyon (86). These relationships are:

Typing

$$P = 4.8988 + 32.123*PMV + 50.24*PMV^2 - 8.1178*PMV^3 - 183.75*PMV^4 + 198.41*PMV^5 - 60.543*PMV^6$$

Thinking

$$P = 1.8763 + 13.389*PMV + 19.226*PMV^2 - 10.401*PMV^3 - 1.5526*PMV^4 + 1.5928*PMV^5$$

Herein is:

- P = the performance loss [%]; $P \geq 0$
- PMV = predicted mean vote, according to ISO-7730 (56).

The performance loss formulas of Kosonen & Tan (49) provide a larger performance loss than the calculated relationship derived by Roelofsens (46)

2.2.9 The research of Jensen, Toftum & Friis-Hansen

In 2009 Jensen, Toftum & Friis-Hansen (50) published a relationship based on addition tasks by 12.000 occupants (male and female with an age range of ≥ 14 years old) in 124 different buildings. The relationship of Jensen, et. al (50) is:

$$RP = 0.9945 - 0.0123*PMV - 0.0069*PMV^2$$

Herein is:

- RP = the relative performance [-]

- PMV = predicted mean vote, according to ISO-7730 (56)

The performance loss calculated with the formula of Jensen et al. (50) is lower than the performance loss calculated with the relationship derived by Roelofsen (46).

2.2.10 The research of Lan, Wargocki & Lian

In 2011 Lan, Wargocki & Lian (51) published a relationship, based on text typing, addition and stroop and number calculation, in a study including 6 females and 6 males with an average age of 23 ± 2 years, namely:

- $RP = 99.865 - 0.215 \cdot PMV - 0.529 \cdot PMV^2 - 0.035 \cdot PMV^3$

Herein is:

- RP = the relative performance [%]
- PMV = predicted mean vote, according to ISO-7730 (56).

The performance loss calculated by Lan et al. (51) is lower than the performance loss derived from Jensen et al. (50). According to a study of Leyten et al. (87) the relationship found by Lan et al. is less representative for office work in an air conditioned environment than the relationship found by Jensen et al. (50), among other things because of the relatively short exposure time (80 minutes) and the relatively long pauses between the exposures, which probably causes underestimation of the temperature effect.

In Figure 2.2.5, the aforementioned relationships on office activities are graphically displayed, for the warm side of the comfort zone.

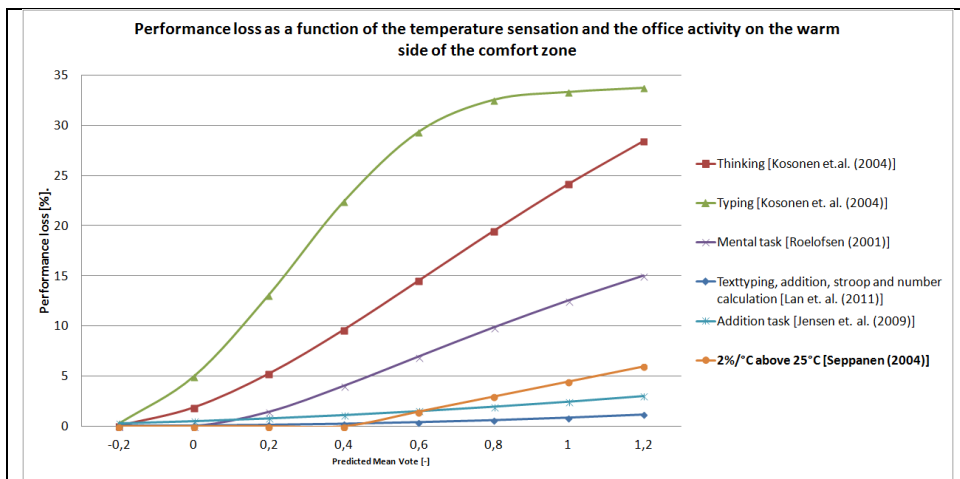

Figure 2.2.5. Office activities.

2.2.11 Performance loss related to thermal discomfort

The functions for performance change due to thermal discomfort {ergo: $-2.0 \leq PMV \leq 2.0$ }, are by default included in the assembled computer model, and explained in [Mohammed & Korb (47), (48), Berglund et al. (54) and Roelofsen (46). Other functions for performance

change may be called upon in the computer model, if necessary, and are explained in (49), (50) and (51).

2.2.12 Standardization of performance loss indicators

Based on a number of indicators these research results show that it is not easy to establish office work performance loss. The various activities, representative for office work, apparently can differ substantially in performance loss (e.g. thinking versus typing and typing versus addition). When putting together a mix of activities representative for an office work, it is important to define to what extent the different activities are included in the study (See Figure 2.2.5.).

Since performance change with investments in the indoor environment are of great interest to investors, designers, facility managers, construction managers, project developers and scientists, the results of scientific research relating performance loss with parameters of the built environment can provide valuable information to enhance human performance. Thus it makes sense to develop relationships that can and will be used within the framework of feasibility studies, design decisions, environmental controls and compiling and checking performance specifications, as well as handling complaints.

A global standardization of indicators for the performance loss in the built environment for activities and a mix of activities by sector, such as those expected in offices, nursing homes, schools, and so on, may solve the problem of the unequivocalness. An example of specification of tasks is shown in NEMA (88):

- performing tasks more accurately
- performing tasks faster without loss of accuracy
- capability to perform tasks longer without tiring
- learning more effectively
- being more creative
- sustaining stress more effectively
- working together more harmoniously
- being more able to cope with unforeseen circumstances
- feeling healthier and therefore spending more time at work
- accepting more responsibility
- responding more positively to requests.

2.2.13 Recommended heat stress limits

In order to assess whether a situation is too hot or too dangerous the limit values as shown in Table 2.2.2 should be considered.

Table 2.2.2. Recommended limits (89)

			Not-acclimatized		Acclimatized	
			Warning	Danger	Warning	Danger
Maximum Sweat-rate	Resting	W/m^2 (g/h)	100 (260)	150 (390)	200 (520)	300 (780)
	SW_{max} Arbejde	W/m^2 (g/h)	200 (520)	250 (650)	300 (780)	400 (1040)
Skin humidity	W_{max}		0,85		1,00	
Dehy-dration	D_{max}	Wh/m^2 (g)	1000 (2600)	1250 (3250)	1500 (3900)	2000 (5200)
Heat Storage	Q_{max}	Wh/m^2	50	60	50	60
Corre-sponding change of Rectal- and Skin tempera-ture	Δt_{re}	$^{\circ}C$	0,8	1	0,8	1
	Δt_{sk}	$^{\circ}C$	2,4	3	2,4	3

Estimation of sweat in g/h or g are based on a mean person with 1,8 m² surface area

T06/52Q80

For acclimatized subjects the calculated maximum sweat rate is greater by 25% and the calculated maximum skin wetness w_{max} ($w_{max} = Esk/Emax = \text{total evaporative heat at the skin surface} / \text{maximum evaporative heat at the skin surface}$) is 1 instead of 0.85 (for non-acclimatized subjects) [NEN-EN-ISO-7933 (2004)].

It should be clear that it is difficult to evaluate a situation on the upper limit values in practice without the use of a thermophysiological human model or extensive measurements on people. For that reason, several researchers attempted to develop heat stress indices as a function of certain personal and environmental parameters to express the degree of heat stress related to the physiological strain responses of the human body (89).

2.2.14 Heat stress indices

Heat stress indices can be divided into empirical and analytical heat stress indices. A comprehensive exposition to heat stress indices is found in (89).

2.2.15 Empirical heat stress indices

An empirical heat stress index is generally based on a correlation between two or more thermal parameters and a human response. The relationship is based on testing people. Examples of empirical heat stress indices are:

- The Effective Temperature Index (ET)
- The Corrected Effective Temperature (CET)
- The Predicted Four Hours Sweat RATE (P4SR)
- Wet Globe Temperature (WGT)
- Wet Bulb Globe Temperature Index (WBGT).

The WBGT-index is standardized (90) and applied worldwide.

2.2.16 Analytical heat stress indices

An analytical heat stress index is generally based on the heat balance of the human body. This type of indices always contains the four environmental parameters, as well as the personal parameters of normal activity and clothing resistance. Examples of analytical heat stress indices are:

- The Heat Stress Index (HSI)
- Required Sweat Rate
- The New Effective Temperature
- The Standard Effective Temperature (SET*)
- PMV* (the operative temperature in Fanger’s equation (56) is replaced by SET*).

The Required Sweat Rate is standardized (91).

Within the method for determining the Heat Stress Index (HSI) there is the ' Allowable Exposure Time ' (AET). AET is based on the calculated required sweat loss (Ereq) and the maximum sweat loss (Emax). The interpretation of the Heat Stress Index is shown in Table 2.2.3.

Table 2.2.3. Interpretation of Heat Stress Index (HSI) (89).

HSI	Effect of eight-hour exposure
-20	Mild cold strain
0	No thermal strain
10-30	Mild to moderate heat strain. Little effect on physical work, but possible decrement on skilled work
40-60	Severe heat strain, involving threat to health unless physically fit. Acclimatisation required
70-90	Very severe heat strain. Personnel should be selected by medical examination. Ensure adequate water and salt intake
100	Maximum strain tolerated by fit acclimatised young men
Over 100	Exposure time limited by rise in deep body temperature

2.2.17 Wet Bulb Globe Temperature Index (WBGT)

The International Standard NEN-ISO 7243 (91) is based on the use of the WBGT index in the evaluation of hot working environments. To determine the Wet Bulb Globe Temperature Index in practice three sensors (See Figure 2.2.6) are necessary to measure the following parameters:

- The black globe temperature
- The natural wet bulb temperature
- The air temperature.



Figure 2.2.6. WBGT transducers.

These transducers are chosen because they respond to environmental parameters, very similar to the human body. The relationship that best correlated with human response is:

- $WBGT = 0.7 \cdot T_{nw} + 0.3 \cdot T_g$

Herein is:

- T_{nw} = the natural wet bulb temperature [°C]
- T_g = the black globe temperature [°C].

In direct sunlight, the black globe temperature overestimates the radiation influence. This is why a third parameter is introduced. In this situation, the measured values are combined with the following relationship:

- $WBGT = 0.7 \cdot T_{nw} + 0.2 \cdot T_g + 0.1 T_a$

Herein is:

- T_a = the air temperature [°C].

2.2.18 Calculation of the WBGT

The WBGT index is a heat stress index most often used in practice and is established according to measurements. Since many research results are related to the WBGT index it makes sense to calculate the WBGT index. Several scientists have discovered that, in practice, the regression functions often result in large deviations with the measured values of the WBGT (92), (93).

In order to calculate the WBGT index more accurately, without the use of a regression formula, a mathematical model is assembled and displayed as follows and is described and validated in (63), (94). The mathematical WBGT model below is added to the computer model.

2.2.19 Wet bulb temperature transducer

The heat balance for the transducer for measuring the wet bulb temperature is:

- $H_e \cdot (T_{db} - T_{nw}) + e_{nw} \cdot \sigma \cdot (T_{nr}^4 - T_{nw}^4) = H_e \cdot (P_{snw} - RH \cdot P_{sdb})$

Herein is:

- T_{db} = the dry bulb temperature [°C]
- T_{nw} = the natural wet bulb temperature [°C]

- T_{mr} = the mean radiant temperature [°C]
- e_{nw} = the emission coefficient of the wet fuze, 0.95 [-]
- P_{snw} = the saturated vapor pressure at T_{nw} [mm Hg]
- P_{sdb} = the saturated vapor pressure at T_{db} [mm Hg]
- H_c = the convective heat coefficient [W/(m².K)]
- H_e = the evaporation coefficient [W/(m². mm Hg)]
- RH = the relative air humidity [%]
- σ = Stefan-Boltzmann constant, $5.6696 \cdot 10^8$ [W/(m².K⁴)]

The convective heat coefficient is to calculate with:

- $H_c = 42.024 \cdot V_{air}^{0.466}$ [W/(m².K)]

The evaporation coefficient is to calculate with:

- $H_e = LR \cdot H_c$ [W/(m². mm Hg)]

Herein is:

- V_{air} = the air velocity [m/s]
- LR = modified Lewis relation [°C/mm HG]

2.2.20 Globe temperature transducer

The heat balance of the transducer for measuring the globe temperature is:

- $H_{cg} \cdot (T_g - T_{db}) = e_g \cdot \sigma \cdot (T_{mr}^4 - T_g^4)$

Herein is:

- T_g = the globe temperature [°C]
- e_g = the emission coefficient of the black globe, 0.95 [-]

The convective heat coefficient of the 15 cm diameter globe is to calculate with:

- $H_{cg} = 15.889 \cdot V_{air}^{0.6}$ [W/(m².K)]

The formulas for the convective heat coefficients are valid for $V_{air} \geq 0.1$ m/s.

The saturated vapor pressure at a temperature (t) can be calculated by:

- $P_s = 6.168 + 0.0358 \cdot t^2 - 0.55 \cdot 10^{-3} \cdot t^3 + 0.105 \cdot 10^{-4} \cdot t^4$ [mm Hg].

2.2.21 Performance loss due to heat stress

This chapter focuses particularly on the hot side of the comfort zone and a number of performance (loss) models, suitable for the calculation of the performance (loss) under heat stress.

2.2.22 The research of Zhao Zhu & Lu.

The research of Zhao, Zhu & Lu (52) is used to determine the performance loss due to heat stress. In this research, 204 healthy students (age: 19 – 26 years) were asked to carry out work in a climate chamber under controlled conditions, in groups of four at air temperatures ranging from 30 to 40 °C and a relative humidity between 40% and 90%.

The work was divided into three categories. One person per group of four performed heavy work, two persons performed medium-duty work and one person performed light work. The heavy work consisted of lifting weights. The medium-duty work consisted of installation work (i.e., connecting pipes). The light work consisted of reading comprehensively. A person should only stop the work if the physiological conditions (i.e., blood pressure, heart rate and

body temperature) indicated danger or whether the person was no longer able to perform the work. The time the work was stopped was registered.

The performance was determined by comparing productivity every twenty minutes during heat stress, with the productivity in the non heat stress situation (26°C/60% and 0.2 m/s). After twenty minutes, the subjects rested for five minutes and drank an adequate quantity of water. Blood pressure, heart rate and body temperature were measured and checked to determine if the execution of work could commence.

Performance loss

The research of Zhao et al. (52) has resulted in two equations per work category for the situation $WBGT \geq 34$. According to the research of Zhao et al. (52), the concept of 'heat tolerance time' is only of importance in the case of $WBGT \geq 34$.

Heavy work

- $T_{htt} = 0.0519*WBGT^3 - 5.6694*WBGT^2 + 206.04*WBGT - 2490.3$ [h].
- $P_{wbgt} = -0.5963*t^2 + 0.9115*t - 0.0676*WBGT + 2.44$ [%]
- $t \leq T_{htt}$

Medium-duty work

- $T_{htt} = 0.1508*WBGT^3 - 16.0601*WBGT^2 + 608.11*WBGT - 7411.8$ [h].
- $P_{wbgt} = -0.364*t^2 + 0.7476*t - 0.05301*WBGT + 2.09$ [%]
- $t \leq T_{htt}$

Light work

- $T_{htt} = 0.0869*WBGT^3 - 9.3769*WBGT^2 + 336.24*WBGT - 4004.5$ [h].
- $P_{wbgt} = -0.286*t^2 + 0.6256*t - 0.07*WBGT + 2.94$ [%]
- $t \leq T_{htt}$

Herein is:

- T_{htt} = the heat tolerance time [h]
- P_{wbgt} = the performance [%].

The mathematical model of Zhao, Zhu & Lu (52), displayed above, is included in the assembled computer model.

2.2.23 The research of Berglund, Gonzalez & Gagge

Berglund, Gonzalez & Gagge (54) derived a performance loss equation for mental activities with a remarkably broad scope regarding discomfort on the warm and hot side of the comfort zone, by using the Gagge model (55), and the research of Mackworth (95) namely:

- $Perfd = -7.5851 + 27.138*Disc - 6.7545*Disc^2 + 0.85945*Disc^3$ [%], $P \leq 100$.

Herein is:

- $Perfd$ = the performance loss [%]
- $Disc$ = the discomfort, according to a 6 point scale of 0-5.

The equation is based on the following principles:

- Test subjects : Men
- Clothing : short trouser
- Age : 18 – 35 years

- Air temperature : 29.4 – 40.6 [°C]
- Relative air humidity : 63 – 70 [%]
- Exposition time : 3 [hour]
- Discomfort-scale : 0.14 – 11.4 (ergo: comfortable – Intolerable).

The calculation results with the equation of Berglund et al. (54) in combination with the Gagge-model (55) show agreement with regard to research results of Hettinger (75). The research results of Hettinger (75) also have a fairly broad scope with regard to the enthalpy of the ambient air. The air temperature, shown in the research of Hettinger (75), on the performance of office employees varied from 18 to 38 °C and a relative humidity of 10 to 100%. The equation of Berglund et al. (54) is also added to the assembled computer model.

2.2.24 Example: Influence of hot and humid environment on mental work

The following is an example to demonstrate the use of the computer model. The model determines to what extent the air humidity, with very high air temperatures, affects the heat stress and the mental performance of employees. The following principles are applied:

- Metabolism = 70 [W/m²]
- Clothing resistance = 0.7 [clo]
- Air velocity = 0.2 [m/s]
- Mean radiant temperature = Air temperature (N.B.: in practice this will likely differ)
- Exposition time = 120 [min]
- WBGT ≥ Reference Value of WBGT, according to NEN-ISO-7243. Ergo, the permitted exposure time is important.

A number of relevant calculation results are, by comparison, shown in Table 2.2.4 and Table 2.2.5.

Table 2.2.4. Calculation results, RH=80% and RH=70%.

T _{air}	RH=80%						RH=70%					
	WBGT	HSI	AET	T _{htt}	P _{wbgt}	Perfd	WBGT	HSI	AET	T _{htt}	P _{wbgt}	Perfd
[°C]	[°C]	[-]	[min]	[min]	[%]	[%]	[°C]	[-]	[min]	[min]	[%]	[%]
34	31.9	102	1766	-	-	38	30.7	89	-	-	-	37
35	32.8	111	398	-	-	44	31.6	101	6077	-	-	43
36	33.8	124	199	-	-	55	32.6	104	902	-	-	53
37	34.8	138	134	193	61	77	33.5	115	272	-	-	73
38	35.7	155	101	142	55	100	34.5	126	165	202	64	100
39	36.7	173	81	85	-	100	35.4	138	119	161	57	100
40	37.7	196	67	48	-	100	36.4	151	93	103	-	100

Table 2.2.5. Calculation results, RH=60% and RH=50%.

T _{air}	RH=60%						RH=50%					
	WBGT	HSI	AET	T _{htt}	P _{wbgt}	Perfd	WBGT	HSI	AET	T _{htt}	P _{wbgt}	Perfd
[°C]	[°C]	[-]	[min]	[min]	[%]	[%]	[°C]	[-]	[min]	[min]	[min]	[%]
34	29.5	71	-	-	-	36	28.1	59	-	-	-	34
35	30.4	81	-	-	-	40	29.0	66	-	-	-	38
36	31.3	92	-	-	-	50	29.9	73	-	-	-	46
37	32.2	101	3321	-	-	68	30.8	81	-	-	-	60
38	33.1	107	538	-	-	100	31.7	91	-	-	-	89
39	34.0	115	237	209	67	100	32.5	101	5045	-	-	100
40	35.0	124	154	184	60	100	33.4	106	549	-	-	100

The shaded area in the table indicates : WBGT ≤ Reference value or WBGT, according to NEN-ISO-7243.

Herein is:

- T_{air} = Air temperature [$^{\circ}\text{C}$]
- WBGT = Wet Bulb Globe Temperature [$^{\circ}\text{C}$]
- HSI = Heat Stress Index [-]
- AET = Allowable Exposure Time [min]
- T_{htt} = Heat tolerance time [min]
- P_{wbgt} = Performance {Reading comprehensively} = $\text{Productivity}_{\text{actual}}/\text{Productivity}_{\text{standard}}$ { $T_{\text{top}}=26^{\circ}\text{C}$, $\text{RV}=60\%$, $V_{\text{air}}=0,2 \text{ m/s}$ } [%].
- Perf d = Performance loss {mental activity} [%].

Based on the calculation results, a situation of very high air temperature and humidity of the air, at an $\text{RH} \geq 50\%$, significantly affects the degree of heat stress, and the permitted exposure time and work performance According to the model of Berglund et al. (54), the performance loss for mental work is 100%, if $\text{RH} \geq 60\%$, with an air temperature of 38°C and more.

2.2.25 Conclusion

The chapter presents an overview of different research studies and researchers' attempts to derive a mathematical relationship between the performance loss and the thermal (dis)comfort of working people, expressed in the mean thermal sensation. The goal of this chapter and research is to present a single computer model and manageable design tool for a variety of disciplines i.e., mechanical engineering, building services and facility management; disciplines that participate in the design of the indoor environment of new or existing buildings and the improvement of working conditions in the workplace.

The single computer model proposed in this chapter is assembled using a validated mathematical human thermophysiological model and a validated mathematical WBGT model, in combination with various mathematical performance (loss) models, based on comfort indices and heat stress indices. Although not perfect, the model is especially usable in the situation of comparative studies. For instance in the early stages of the design process, the computer model assists in making better/the right (design) decisions regarding the thermal aspects of the indoor environment, whether or not in combination with validated building simulation models.

The use of a dynamic thermophysiological model, in combination with the aforementioned models, enables the evaluation of the thermal influence of every architectural and building service and related adjustments for people and organizations. For example, the reduction of the average number of unworkable or less than workable hours per year results in less of a loss in productivity for a company or institute. Experience has shown that with the use of a thermophysiological model, in combination with the aforementioned models, the proposed recommendations differ greatly from the conventional solutions without the use of such models. In addition, the use of a combination of models, as shown above, makes it possible to negotiate solutions and better balance investments with regards for profits in workable hours (62), (96,97).

Not rarely is it shown that taking the right measures to improve the indoor climate will result in significant energy savings. This side effect is not a coincidence, but a consequence of the applied strategy for resolving the problems with the eye focused on human health (62), (96), (97).

For the International Organization for Standardization (ISO) has clearly a role to play with regard to global standardization of performance loss indicators in the built environment for activities and a mix of certain activities by sector (like these are to be expected in offices, nursing homes, schools, and so on), so that innovation, but above all the improvement and the pursuit of high-value, within the built environment will be given a worldwide stimulus.

2.2.26 Acknowledgments

The assistance of dr. C. Bazley for editing of this chapter is gratefully acknowledged. Special thanks goes to dr. L.G. Berglund for reviewing and editing of this chapter.

2.3 Improvement of the Stolwijk model by adjusting the model with regard of clothing, thermal sensation and skin temperature

ABSTRACT.

There has been a growing demand from research and the industry for detailed models predicting human thermophysiological responses. Thermophysiological models, as a design aid, are necessary for the design and evaluation of the indoor thermal climate. Stolwijk (98) developed a thermophysiological human model which, to day, is still the basis and inspiration for many other thermophysiological human models (99), (100). The multizonal Stolwijk model as compared to the two-node Gagge model (55) was more extensive in scope, e.g. because the heat balance of the body is divided into the head, the trunk, arms, hands, legs and feet. Some later on developed thermophysiological models are usually tailored to specific applications, for instance the cold side of the comfortzone (101) or Chinese people (102). Often the source code of the computer programs of these models are not released and the computer programs are not made available for the professional practice. For that reason is in this chapter chosen for the by NASA developed Stolwijk model. The model is made available by NASA and still used for research in the industry and research community by among others NASA (18), the Biophysics and Biomedical Modeling Division US Army Research Institute of Environmental Medicine (66) and universities (103), (104), (105).

The original Stolwijk model is not equipped with clothing, thermal sensation, comfort indices, individual characteristics and performance loss models.

This chapter attempts to modify the model to include clothing, thermal sensation as well as the calculation of the percentage of dissatisfied as a result of the general discomfort, so the model is useful for the evaluation of thermal comfort in the professional practice of the built environment.

Some in the literature described methods with regard of clothing, the research of Fiala as well as some in the literature recommended and validated adjustments, to improve the simulation of the skin temperature per body segment, are implemented in the here assembled Stolwijk computer model. Finally, for verification of the above adjustments, the model is compared with experiments conducted in the field of thermal sensation at various forms of temperature change.

By adding clothing and thermal sensation, suitable for the assessment of stationary and dynamic thermal conditions, and fixed with this the percentage of dissatisfied, the scope of the Stolwijk model has become larger than it was before.

On the basis of the calculations and the experimental results, it is concluded that the adjusted Stolwijk model is suitable for the simulation of the thermal sensation under dynamic thermal conditions.

Keywords

Mathematical human modelling, dynamic thermal sensation.

2.3.1 Introduction

There has been a growing demand from research and the industry for detailed models predicting human thermophysiological responses. Thermophysiological models, as a design aid, are necessary for the design and evaluation of the indoor thermal climate.

Stolwijk (98) developed a thermophysiological human model which, to day, is still the basis and inspiration for many other thermophysiological human models (99). Some later on developed thermophysiological models are usually tailored to specific applications, for instance the cold side of the comfortzone (101) or Chinese people (102). Often the source code of the computer programs of these models are not released and the computer programs are not made available for the professional practice.

The Stolwijk model was developed for the NASA (National Aeronautics and Space Administration) with the aim to create a mathematical model to simulate the thermoregulation of a human, under dynamic conditions. This model simulated the physiological responses of people in different environmental conditions. Default in this model was a naked male person with a length of 1.72 m and a weight of 74.4 kg. The Stolwijk model as compared to the Gagge model (55) was more extensive in scope, e.g. because the heat balance of the body is divided into the head, the trunk, arms, hands, legs and feet. In addition, the aforementioned body parts were divided into a core, a muscle layer, a fat layer and a skin layer. NASA made the Stolwijk model available for the professional practice and is well described in literature (98), (106), (107), (108) and extensively validated (107), (109), (103), (110). Because the body was divided into several body parts, one would expect that the Stolwijk model basically is suitable for the evaluation of the general and local discomfort. The original Stolwijk model however was not equipped with clothing, thermal sensation, comfort indices, individual characteristics and performance (loss) models. The model is made available by NASA and still used for research in the industry and research community by among others NASA (18), the Biophysics and Biomedical Modeling Division US Army Research Institute of Environmental Medicine (66) and universities (103), (104), (105).

This chapter attempts to modify the model to include clothing, thermal sensation as well as the calculation of the percentage of dissatisfied as a result of the general discomfort; so the model is useful for the evaluation of thermal comfort in the built environment. Furthermore some in the literature recommended and validated adjustments, to improve the simulation of the skin temperature per body segment (103), are implemented in this reconfigured Stolwijk model. Finally, for verification of the above adjustments, the model is compared with experiments conducted in the field of thermal sensation at various forms of temperature change.

2.3.2 Stolwijk model

Passive part

The passive part of the model consists of five cylinders and a sphere with adjusted dimensions (the dimensions are determined by measurements on subjects) (see Figure 2.3.1). The cylinders represent the trunk, arms, hands, legs and feet, the sphere represents the head. Each element consists four concentric layers or compartments that comprise the core, the muscle tissue, the fat and the skin layers. The model also contains a central blood compartment, which represents the large arteries and veins. In this compartment heat is exchanged with the other compartments by convective heat distribution (this occurs when blood flows to the other compartments). The model assumes that the body is symmetrically built up; the legs are represented by one cylinder. The total passive system consists of 25 nodes: five cylinders and a sphere, each consisting four layers, and one central blood compartment.

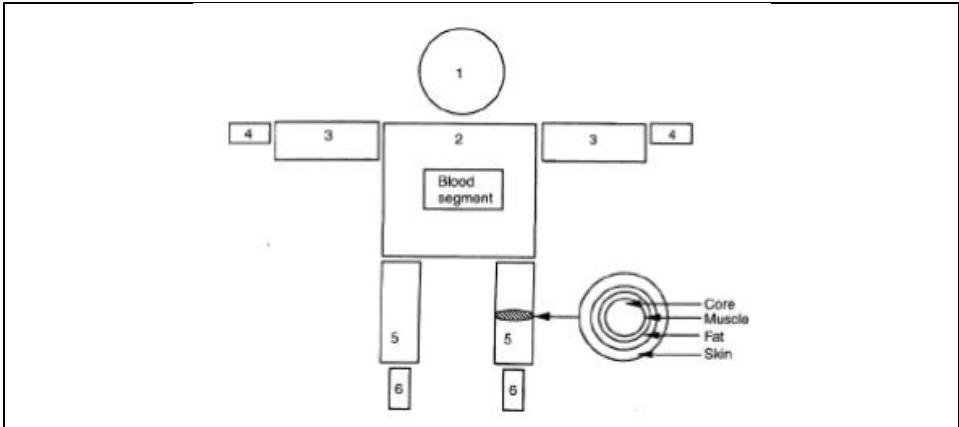

Figure 2.3.1. Schematic representation of the passive part of the Stolwijk model (108).

Active part

The active part of the model is the thermoregulation system (see Figure 2.3.2) which perceives the ambient temperature and consists of an integrated regulatory system. It is a simplified representation of the actual human thermoregulation system and is based on set point values. The set point value is basically the temperature for each node that a node would have in a neutral condition. If the value in a node is different from this set point value then the regulatory mechanisms are used.

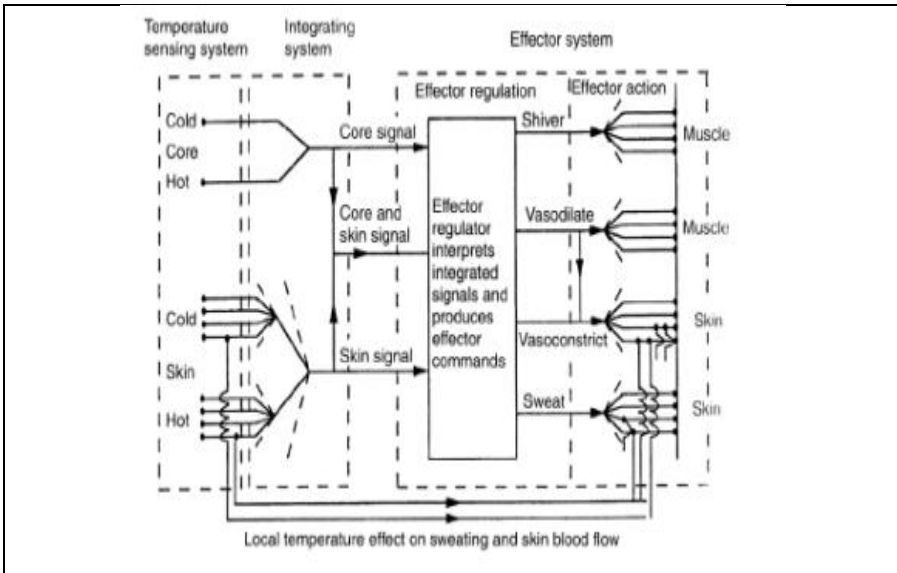

Figure 2.3.2. Schematic representation of the active part of the Stolwijk model (108).

2.3.3 Clothing

The original Stolwijk model was not equipped with clothing. In order for the model to be useful in the evaluation of the thermal comfort within the built environment it is necessary that clothing can be included in the assessment.

For that reason, the Stolwijk model, for all body segments, is modified with the following equations:

- $Fcl_i = 1 / (1 + 0.155 * (\alpha_{c,i} + \alpha_{r,i})) * clo_i * 1.163$
- $Facl = 1 + 0.15 * clo_i$
- $clo_e = clo_i - (Facl - 1) / (0.155 * Facl * (\alpha_{c,i} + \alpha_{r,i}))$
- $Fpcl_i = 1 / (1 + 0.143 * \alpha_{c,i} * SQR(v_{air}/0.1)) * clo_e * 1.163$
- $Lr_i = 2.02 * (T_{sk,i} + 273.15) / 273.15$
- $E_{max_i} = (P_{skin_i} - P_{air}) * Lr * \alpha_{c,i} * SQR(v_{air}/0.1) * Fpcl_i * S_i$
- $HF_{sk,i} = Q_{sk,i} - BC_{sk,i} - E_{sk,i} + TD_{fat,i} - (\alpha_{r,i} * Fcl_i * (T_{sk,i} - T_{mrt}) - \alpha_{c,i} * Fcl_i * SQR(v_{air}/0.1) * (T_{sk,i} - T_{air})) * S_i$

Herein is:

- i = number segment [-]
- Fcl = Burton clothing efficiency factor [-]
- $Fpcl$ = Nishi permeation efficiency factor for clothing [-]
- E_{max} = maximum evaporative heat loss [kcal/h]
- α_c = convective heat transfer coefficient [kcal/(m².h.K)]
- clo_i = intrinsic clothing resistance [clo]
- clo_e = effective clothing resistance [clo]
- P_{skin} = saturated water vapor pressure at skin temperature [mmHg]
- P_{air} = vapor pressure in environment [mmHg]
- v_{air} = air velocity [m/s]
- HF_{sk} = rate of heat flow into or from segment [kcal/h]
- Q_{sk} = total metabolic heat production [kcal/h]
- BC_{sk} = convective heat transfer between central blood and segment [kcal/h]
- E_{sk} = total evaporative heat
- TD_{fat} = thermal conductance between fat and skin [kcal/h]
- α_r = radiant heat transfer coefficient [kcal/(m².h.K)]
- T_{sk} = skin temperature [°C]
- T_{mrt} = mean radiant temperature [°C]
- T_{air} = air temperature [°C]
- S = surface body part [m²]
- Lr = Lewis relation; ratio of the evaporative heat transfer coefficient to the convective heat transfer coefficient [°C/mmHg].

In this study the calculation of the clo value is executed with a for this study assembled computer program, based on a model of J. Lotens (111). It calculates the clothing insulation values for a four cylindrical model of the human body. The model is covered with a clothing layer except for head and hands (111).

2.3.4 Dynamic thermal sensation

In 1998 Fiala also developed a thermophysiological model (112), based on the Stolwijk model. Other models, like for instance the ThermoSEM model used by the Maastricht University and the Eindhoven University of Technology, are in turn based on the Fiala model (113). The

original model of Fiala also assumes a standard male person weighing 73.5 kg, a body fat percentage of 14%, a Dubois area of 1.9 m² and a basal metabolic rate of 87.1 Watt. As with the Stolwijk model, the model of Fiala is split into passive and active parts. The core temperature, the mean skin temperature and the rate at which the mean skin temperature changes are the parameters which control the regulatory mechanisms. The control principle is equivalent to the control system of the Stolwijk model; as the core temperature or the mean skin temperature differs from the set point values than the regulatory mechanisms are in operation (114).

In the Fiala model an equation is included to predict the thermal sensation under dynamic conditions, the so called Dynamic Thermal Sensation (DTS), based on the simulated core temperature and the mean skin temperature. The equation for predicting the thermal sensation is based on a large number of independent experiments. Using a multivariate analysis it was found that the mean skin temperature, the core temperature and the rate at which the mean skin temperature changes are the parameters affecting the thermal sensation under dynamic conditions. The thermal sensation was assessed on the basis of the ASHRAE seven-point scale. Experiments showed that the predicted DTS and the PMV were in agreement. In the studies of Fiala two versions of the dynamic thermal sensation were published. Both versions are included in the modified Stolwijk computer model, according to the following equations:

DTS-version 1 (112)

- $DTS1=3*\tanh(f_{sk}+\phi+\psi)$ [-]

Where:

- $f_{sk} = 1.026*\Delta T_{sk,m}$ [-] ; for $\Delta T_{sk,m} > 0$
- $f_{sk} = 0.298*\Delta T_{sk,m}$ [-] ; for $\Delta T_{sk,m} < 0$
- $\Delta T_{sk,m} = (T_{mean\ skin} - 34.4)$ [K]
- $\phi = 6.662*\exp(-0.565/\Delta T_{hy})*\exp(-7.634/(5-\Delta T_{sk,m}))$ [-] ; $\phi=0$ when $\Delta T_{hy}\leq 0$ or $\Delta T_{sk,m}\geq 5$
- $\Delta T_{hy} = (T_{hypothalamic} - 37.0)$ [K]
- $\psi = (\tau + \tau_+) / (1+\phi)$ [-]
- $\tau = 0.114*dT_{sk,m}/dt$ [-] ; for $dT_{sk,m}/dt < 0$
- $\tau_+ = 0.137*(dT_{sk,m}/dt)_{max}.\exp(-0.681*\Delta t)$ [-] ; for $dT_{sk,m}/dt > 0$
- $\Delta t = t-t_0$ [h]
- $t_0 =$ time of occurrence of highest rate $dT_{sk,m}/dt$ [h].

DTS-version 2 (19)

- $DTS2=3*\tanh(f_{sk}+\phi+\psi)$ [-]

Where:

- $f_{sk} = 1.08*\Delta T_{sk,m}$ [-] ; for $\Delta T_{sk,m} > 0$
- $f_{sk} = 0.30*\Delta T_{sk,m}$ [-] ; for $\Delta T_{sk,m} < 0$
- $\Delta T_{sk,m} = (T_{mean\ skin} - 34.4)$ [K]
- $\phi = 7.94*\exp(-0.902/(\Delta T_{hy}+0.4))+7.612/(\Delta T_{sk,m}-4)$ [-] ; $\phi=0$ when $\Delta T_{hy}+0.4\leq 0$ or $\Delta T_{sk,m}-4\geq 0$
- $\Delta T_{hy} = (T_{hypothalamic} - 37.0)$ [K]
- $\psi = (\tau + \tau_+) / (1+\phi)$ [-]
- $\tau = 0.11*dT_{sk,m}/dt$ [-] ; for $dT_{sk,m}/dt < 0$
- $\tau_+ = 1.91*(dT_{sk,m}/dt)_{max}.\exp(-0.681*\Delta t)$ [-] ; for $dT_{sk,m}/dt > 0$

- $\Delta t = t - t_0$ [h]
- $t_0 =$ time of occurrence of highest rate $dT_{sk,m}/dt$ [h].

2.3.5 Predicted percentage of dissatisfied

The individual assessments result in a certain spread around the average value. It is useful to predict the percentage of people who will normally experience the thermal environment as uncomfortable (PPD). This PPD (Predicted Percentage of Dissatisfied) can be derived from the PMV (Predicted Mean Vote), according to (NEN-EN-)ISO-7730 (56). The PPD provides a quantitative prediction in percentage terms of the number of people who are dissatisfied with the thermal climate. DTS and the PMV are in general agreement with each other (112) and it is possible to calculate the PPD using the following formulation:

- $PPD = 100 - 95 * (-0.03353 * DTS^4 - 0.2179 * DTS^2)$ [%].

2.3.6 Validation and modification of the Stolwijk model

The characteristics of the multi-segmented human thermal model of Stolwijk were evaluated by Munir et al. (103) using skin temperature measurements at low activity in transient environments by comparing the results of two series of experiments, involving ten and seven subjects. The subjects were exposed to stepwise changes in environmental conditions, including neutral, low, and high ambient temperatures. It was concluded that the original Stolwijk model accurately predicted the absolute value of and the tendency of the transient mean skin temperature. This suggests that the original Stolwijk model was valid for the prediction of the transient mean skin temperature of an “average” person in low-activity conditions. Some of the body segments showed deviations of local skin temperature. Modification of the distribution of the basal skin blood flow and the distributions of vasoconstriction and workload significantly improved the predicted results of both thermally neutral condition and thermal-transient conditions (103).

The above mentioned modifications are displayed in Table 2.3.1 and included in this modified Stolwijk computer model.

Table 2.3.1. Modifications in the Stolwijk model (103).

Segment	Basal effective bloodflow [l/h]	Fraction of vasoconstriction command applicable to skin of segment I	Distribution extra heat production muscle compartments
	BFB(I) [l/h]	SKINC(I) [-]	WORKM(I) [-]
Head	4.54	0.06	0.00
Trunk	3.88	0.06	0.66
Arms	1.10	0.19	0.19
Hands	1.50	0.11	0.02
Legs	1.79	0.20	0.11
Feet	0.66	0.38	0.02

2.3.7 Steady state

Along with the development of a thermophysiological model, based on Chinese people (SJTU model), Zhou et al. (102) compared a number of models for a stationary situation. Table 5.2 shows the prediction results of Zhou et al. (102) with different thermal sensation models, all

based on western people. For comparison, the calculation results of the modified Stolwijk model are included, at the end of Table 2.3.2.

Table 2.3.2. Prediction of thermal sensation with different models for a steady state situation (102), (this study).

Model	Thermal sensation [-]	Toperative [°C]				
		20	23	26	29	32
Fanger/ISO-7730	PMV	-1.88	-0.84	0.19	1.24	2.31
Fiala	DTS	-2.29	-1.65	-0.82	0.10	1.97
UC Berkeley	TS	-1.61	-0.56	0.08	0.88	2.45
Stolwijk (this study)	DTS1	-1.83	-1.05	-0.07	1.03	1.80
Stolwijk (this study)	DTS2	-1.84	-1.01	0.23	1.31	2.02

Activity = 1 met; clothing resistance = 0,57 clo; air velocity = 0.1 m/s and relative humidity = 50%.

The Stolwijk model in combination with the DTS2 version of the dynamic thermal sensation, in the stationary situation, best approximates the Fanger/ISO 7730 model.

2.3.8 Step changes in ambient temperature

In the experiments of Gagge et al. (115) three seminude (dressed only in shorts) male subjects, seated quietly, were exposed for two hours to steady state ambient temperatures of around 13, 18 and 48°C. The two-hour exposures to around 18°C and 48°C were part of two separate four-hour experiments in which the subjects underwent sudden changes in ambient temperature from neutral thermal sensation to the particular climate and back to neutral. The subjects were quickly transferred after one hour (t=60 min) into another room at either 18°C or 48°C. After 2 hours (t=180 min) the subjects moved back into the neutral environment for one hour. The wall temperature was equal to the temperature of the still air. Air movement was constant at 0,05 m/s and the relative humidity was less then 40%.

The results of the experiments as well as the results of the simulation with the modified Stolwijk model are displayed in figure 2.3.3 to 2.3.8.

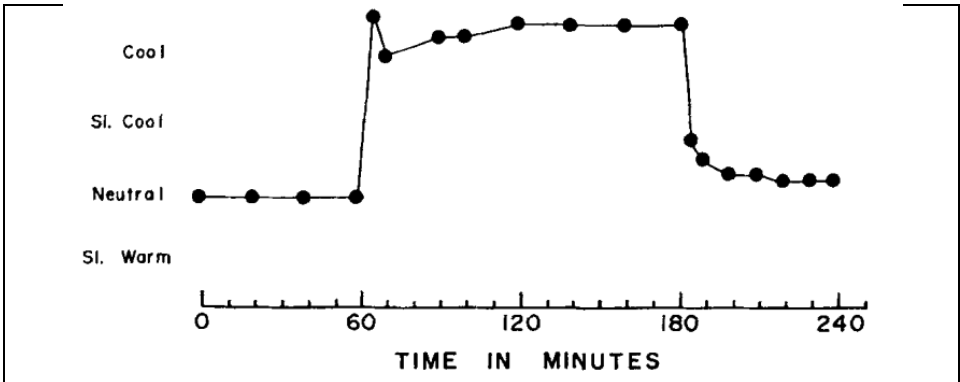

Figure 2.3.3. Vair=0.05 m/s, Iclo=0. Neutral: 29°C/RH=40%, Cool:17.5°C/RH=31%, Neutral: 29°C/RH41% [(115)].

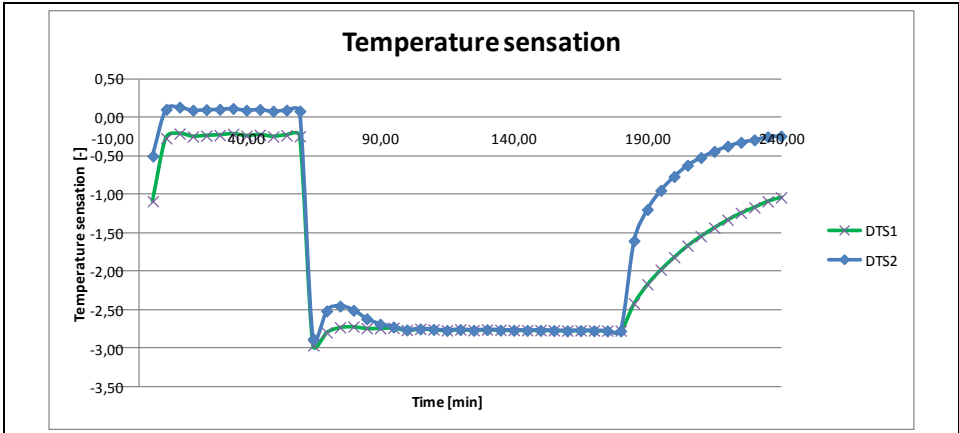

Figure 2.3.4. Simulated Neutral-Cool-Neutral situation as displayed in figure 2.3.3.

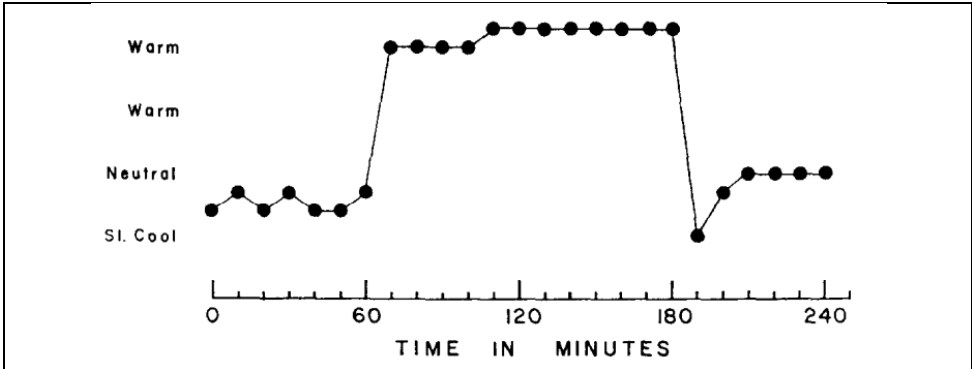

Figure 2.3.5. $V_{air}=0.05$ m/s, $I_{clo}=0$. Neutral: 28.1°C/RH=43%, Warm: 47.8°C/RH=27%, Neutral: 28.3°C/RH=44% (115).

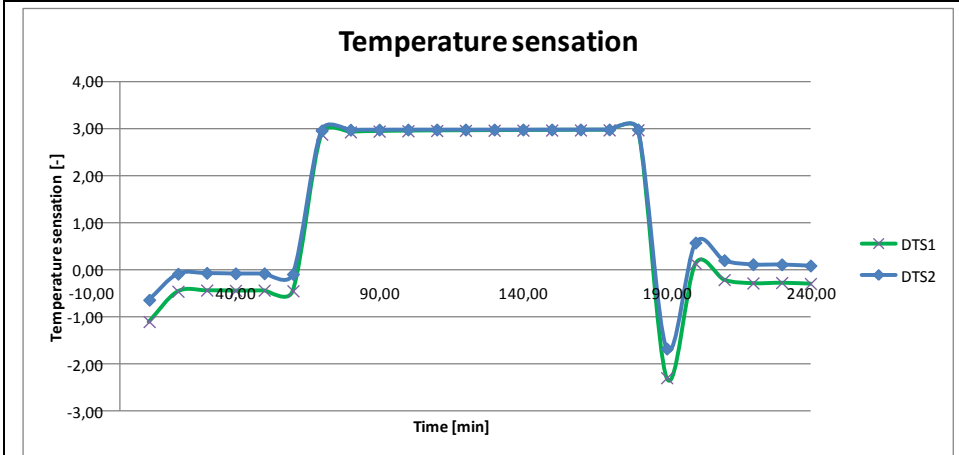

Figure 2.3.6. Simulated Neutral-Warm-Neutral situation as displayed in figure 2.3.5.

Shitzer et al. (116) research ran three experiments with five young male subjects (age 22–27 years) to investigate the effects of three different environments on the recovery from heat stress. The duration of all three experiments was two hours. The first hour was spent on a bicycle ergometer working at a load of about 60 Watt in a 40°C and about 25% relative humidity chamber. In the second hour, subjects were exposed while sitting in a more comfortable environment. These environments included a fixed temperature equal to the one preferred by each subject in a preliminary test (condition 1) and two varied schemes which were either at 5°C above (condition 2) or 5°C below (condition 3) the preferred temperature. Changes in chamber temperature were made according to the subjects requests.

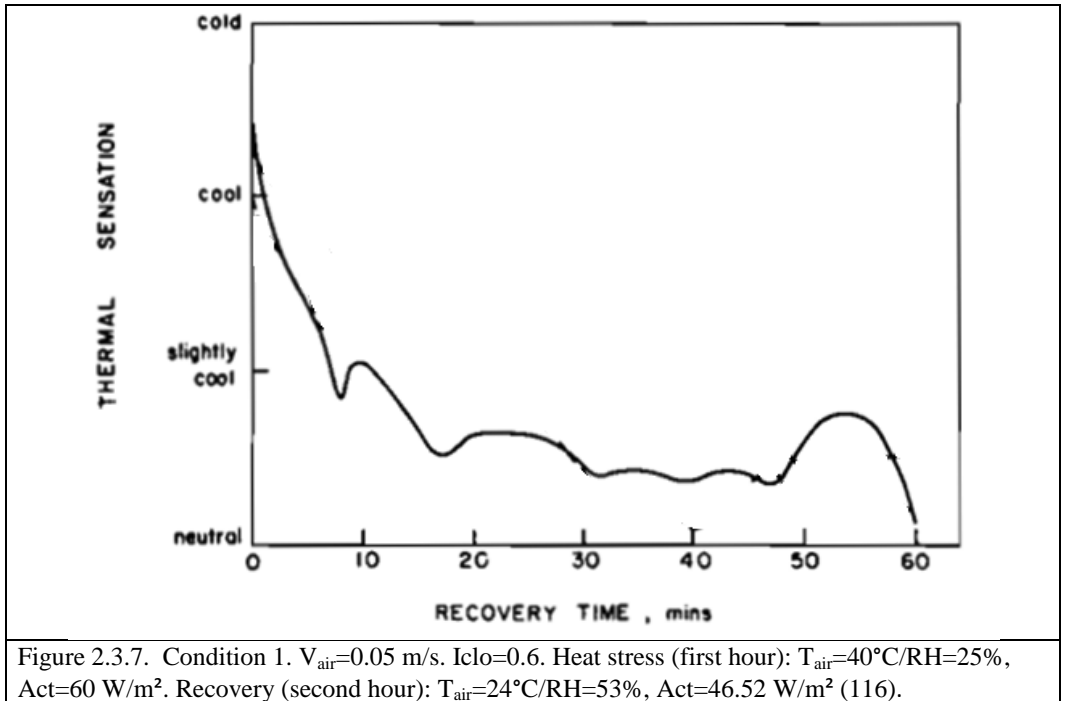

Figure 2.3.7. Condition 1. $V_{air}=0.05$ m/s. $I_{clo}=0.6$. Heat stress (first hour): $T_{air}=40^{\circ}\text{C}/\text{RH}=25\%$, $Act=60$ W/m². Recovery (second hour): $T_{air}=24^{\circ}\text{C}/\text{RH}=53\%$, $Act=46.52$ W/m² (116).

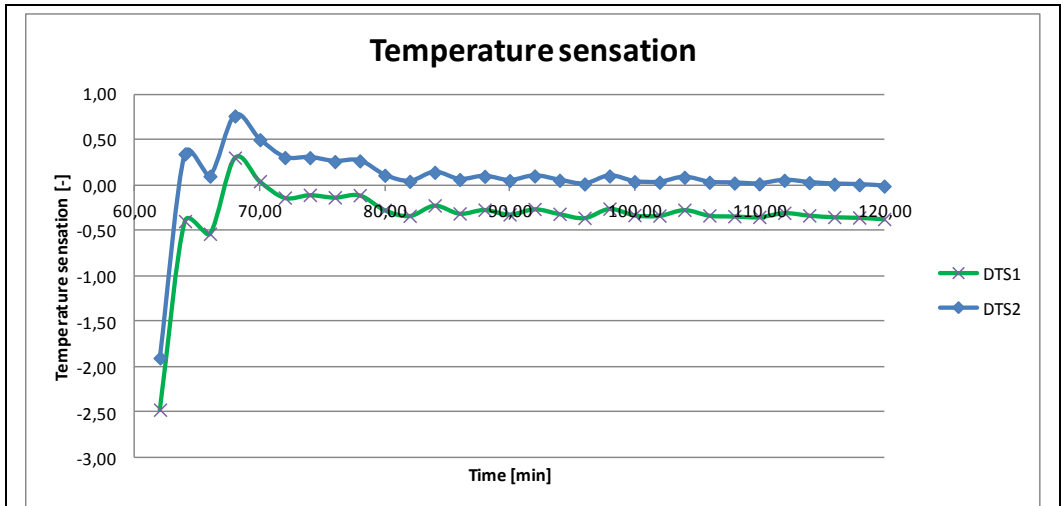

Figure 2.3.8. Simulated thermal sensation condition 1 (Recovery: second hour) as displayed in figure 2.3.7.

2.3.9 Temperature ramp

The study of Berglund and Gonzalez (117) consisted of testing subjects dressed in three different levels of clothing (0,38, 0,54 and 0,74 clo_{intrinsic}) each of whom experienced seven rates of temperature change (0, ±0,5, ±1 and ±1,5 K/h). Twelve college-age subjects (6 men and 6 women) were exposed for each of the 21 test conditions. The 0 K/h tests were used as controls. The air and wall temperatures were always equal and the air movement was constant 0,1 m/s. Throughout the testing the dew point was 12 °C. Each subject was randomly assigned to a group of three men and three women. There were six groups in all for a total of 36 participants. Each group tested seven random combinations of clothing and temperature change including a control condition on seven consecutive afternoons. Two different groups experienced each test condition.

The subjects entered the test chamber at 12:30 p.m. Until 1:00 p.m. the temperature was held at a constant 25°C at which time the temperature ramp commenced. Every half an hour starting at 1:00 p.m. the subjects marked a thermal response ballot to indicate their judgement of thermal sensation, discomfort and thermal acceptability. The subjects were not allowed to discuss the environment or how they felt. The subjects were not given any information about the environment or that it was changing. During the tests the subjects did other things i.e. conversed, studied, played games or did other things like sewing and sketching. They were not completely sedentary but walked slowly about the test chamber for five minutes every thirty minutes (≈ 1,2 met) (117).

According to Berglund and Gonzalez (117) the mean thermal sensation votes of the experiments can be described by a multiple linear regression in terms of the operative temperature and clo_{nevin}:

- $T_{sens} = 0.305 * T_{operative} + 0.996 * clo_{nevin} - 8.08$ ($r=0.95$).

Herein is:

- T_{sens} = thermal sensation, according to a seven point scale [-]
- $T_{operative}$ = The operative temperature [°C]
- Clo_{nevin} = the clothing resistance according to the method used by Nevin [clo]

- $Cl_{o\text{intrinsic}} = 0.79 * Cl_{o\text{nevin}}$ (118).

The simulated situations with the Stolwijk model are plotted against thermal sensations for all test conditions (117) in figure 2.3.9 to 2.3.26.

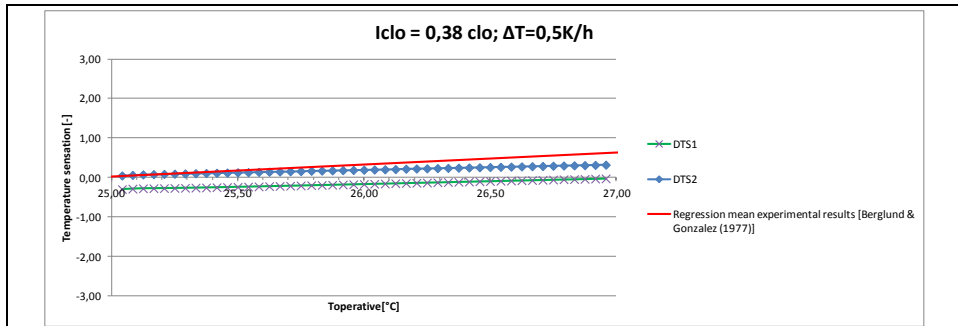

Figure 2.3.9. Temperature ramp $\Delta T=0.5$ K/h, $Iclo_{\text{intrinsic}} = 0.38$.

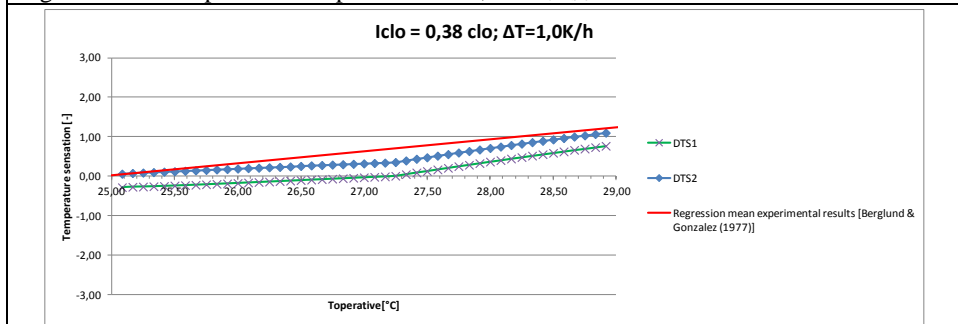

Figure 2.3.10. Temperature ramp $\Delta T=1.0$ K/h, $Iclo_{\text{intrinsic}} = 0.38$.

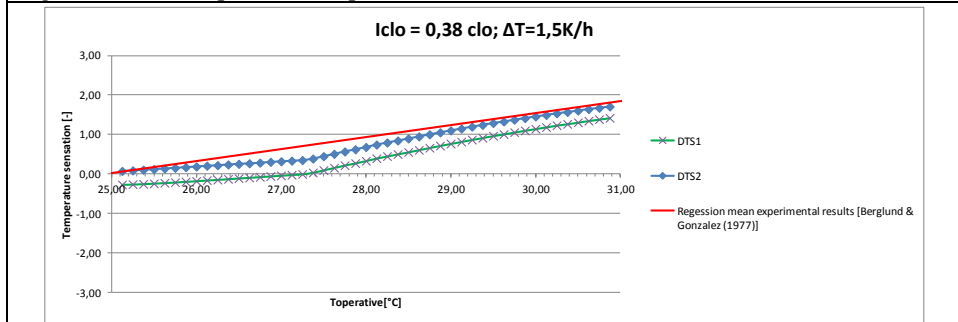

Figure 2.3.11. Temperature ramp $\Delta T=1.5$ K/h, $Iclo_{\text{intrinsic}} = 0.38$.

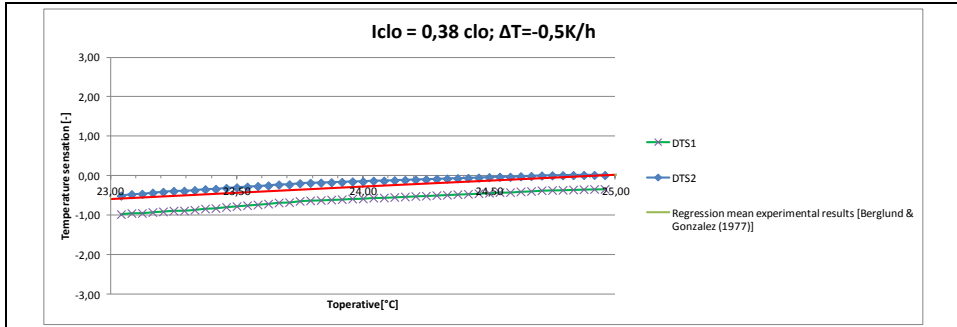

Figure 2.3.12. Temperature ramp $\Delta T = -0.5$ K/h, $I_{clo_{intrinsic}} = 0.38$.

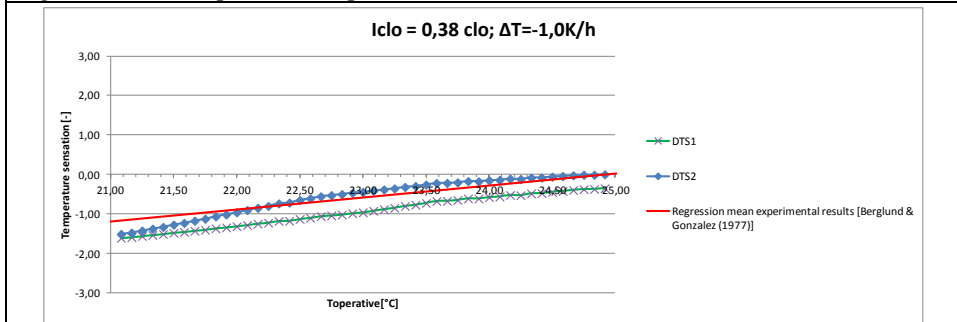

Figure 2.3.13. Temperature ramp $\Delta T = -1.0$ K/h, $I_{clo_{intrinsic}} = 0.38$.

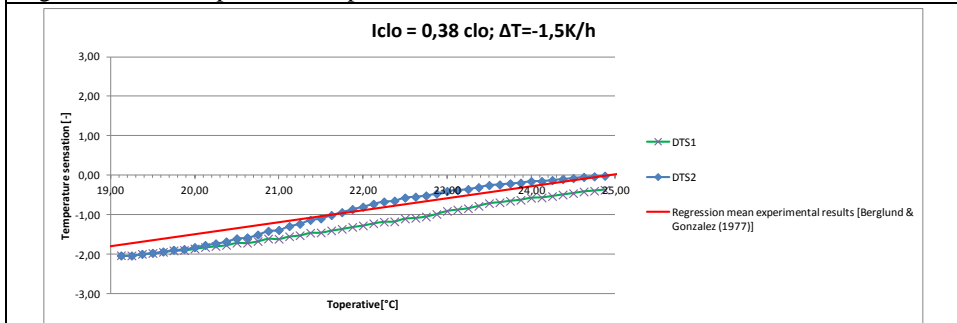

Figure 2.3.14. Temperature ramp $\Delta T = -1.5$ K/h, $I_{clo_{intrinsic}} = 0.38$.

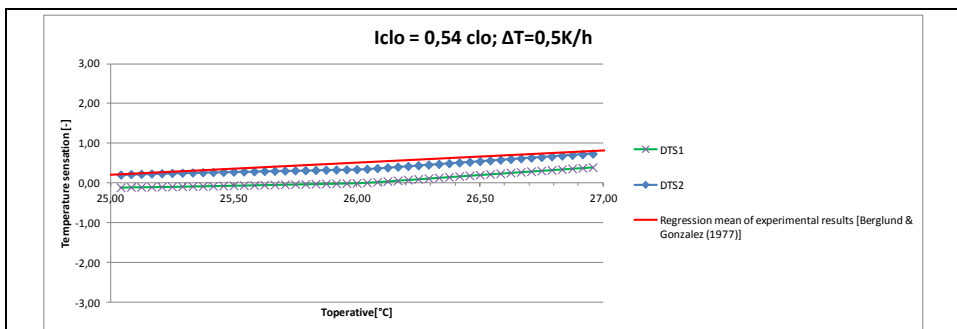

Figure 2.3.15. Temperature ramp $\Delta T = 0.5$ K/h, $I_{clo_{intrinsic}} = 0.54$.

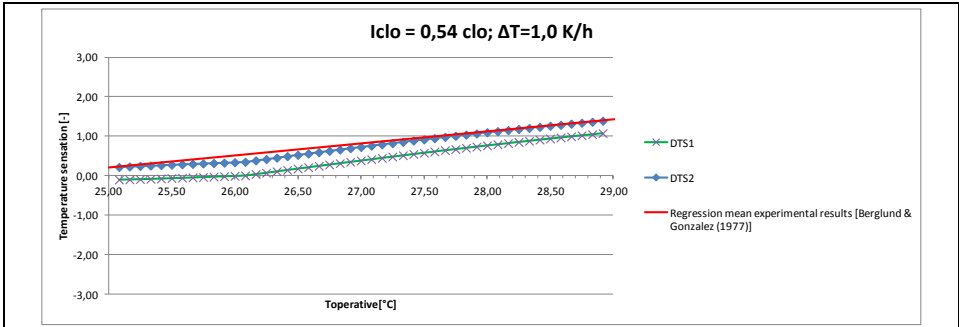

Figure 2.3.16. Temperature ramp $\Delta T=1.0$ K/h, $I_{clo_{intrinsic}} = 0.54$.

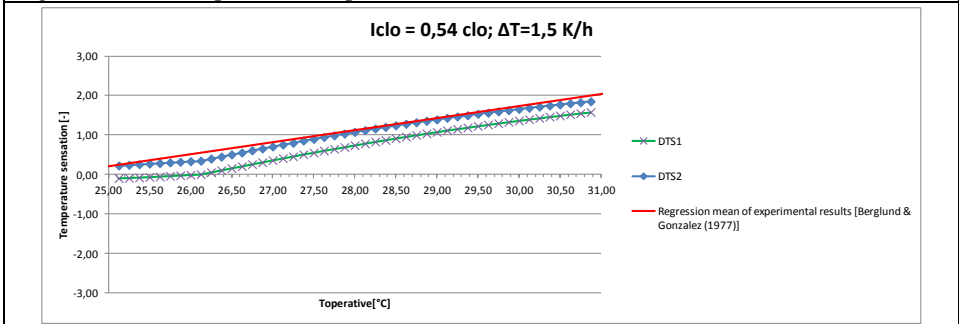

Figure 2.3.17. Temperature ramp $\Delta T=1.5$ K/h, $I_{clo_{intrinsic}} = 0.54$.

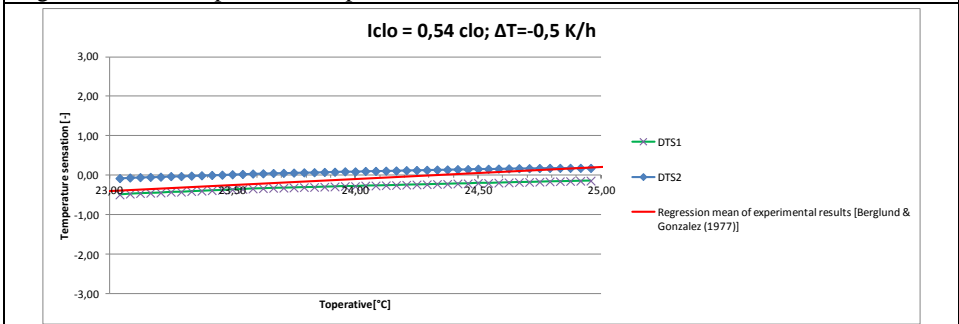

Figure 2.3.18. Temperature ramp $\Delta T=-0.5$ K/h, $I_{clo_{intrinsic}} = 0.54$.

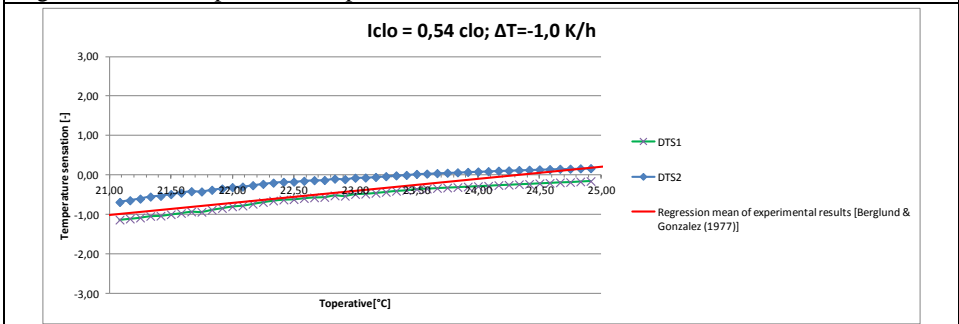

Figure 2.3.19. Temperature ramp $\Delta T=-1.0$ K/h, $I_{clo_{intrinsic}} = 0.54$.

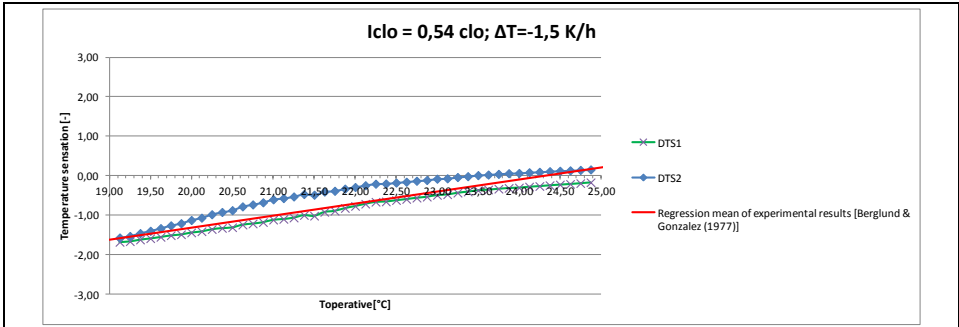

Figure 2.3.20. Temperature ramp $\Delta T = -1.5$ K/h, $I_{clo_{intrinsic}} = 0.54$.

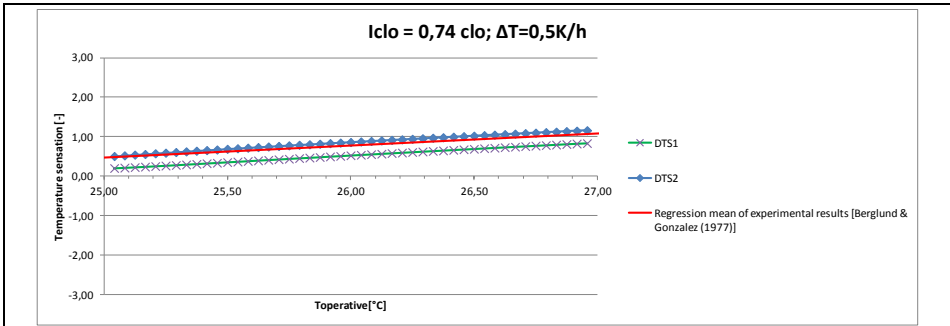

Figure 2.3.21. Temperature ramp $\Delta T = 0.5$ K/h, $I_{clo_{intrinsic}} = 0.74$.

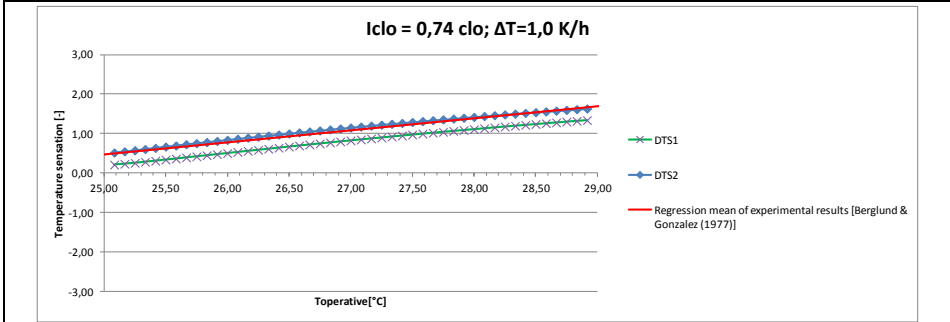

Figure 2.3.22. Temperature ramp $\Delta T = 1.0$ K/h, $I_{clo_{intrinsic}} = 0.74$.

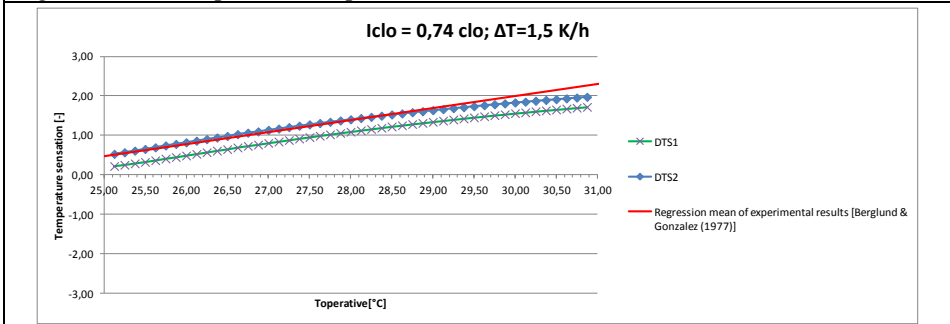

Figure 2.3.23. Temperature ramp $\Delta T = 1.5$ K/h, $I_{clo_{intrinsic}} = 0.74$.

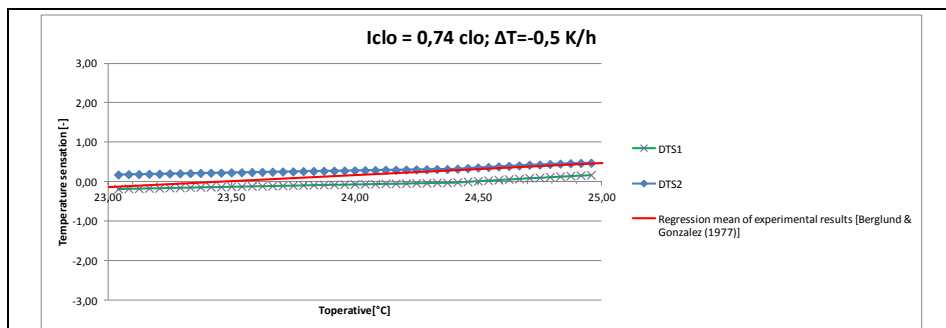

Figure 2.3.24. Temperature ramp $\Delta T = -0.5$ K/h, $I_{clo_{intrinsic}} = 0.74$.

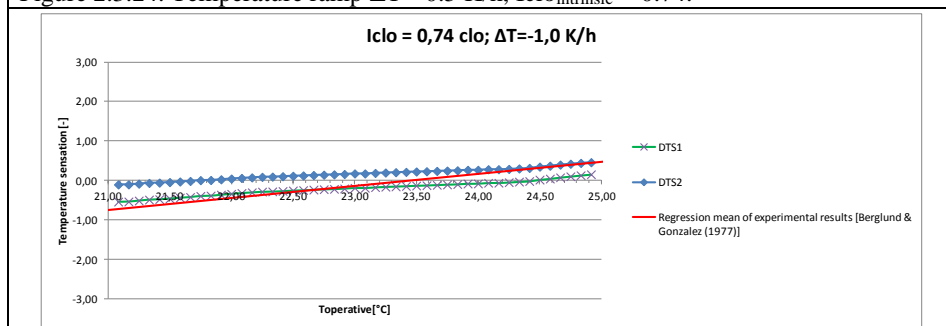

Figure 2.3.25. Temperature ramp $\Delta T = -1.0$ K/h, $I_{clo_{intrinsic}} = 0.74$

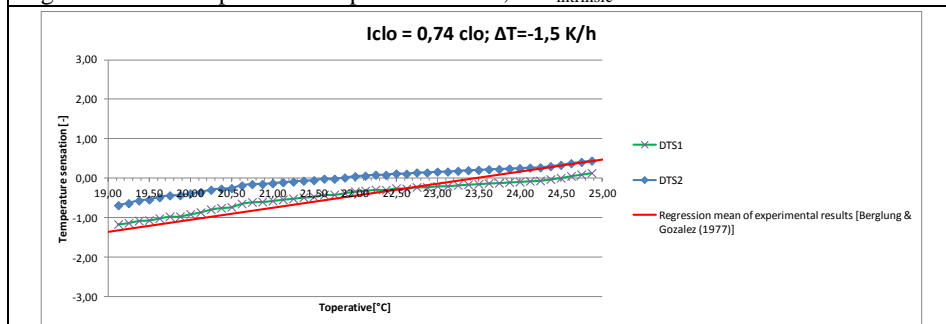

Figure 2.3.26. Temperature ramp $\Delta T = -1.5$ K/h, $I_{clo_{intrinsic}} = 0.74$

2.3.10 Cyclic variations in operative temperature

Schellen (114) studied the effects of a moderate temperature drift on physiological responses, thermal comfort, and productivity of eight young adults (age 22–25 years) and eight older subjects (age 67–73 years). The subjects were exposed to two different conditions: S1-a control condition; constant temperature of 21.5°C; duration: 8 h; and S2-a transient condition; temperature range: 17–25°C, duration: 8 h, temperature drift: first 4 h: +2 K/h, last 4 h: -2 K/h. The subjects visited the climate room on two occasions (S1 and S2) with different indoor climate conditions. The order of the conditions alternated (e.g. subject 1 started with S1 and ended with S2, subject 2 started with S2 and ended with S1, subject three started with S1, etc.). To increase the mixing of the air a fan was installed, resulting in a air velocity near the subject of 0.19 m/s. The total heat resistance of the clothing, including desk chair, was approximately 0.98 clo. The subjects continuously performed office tasks; their metabolic rate was approximately 1.2 met (114).

The simulated S2-situation with the Stolwijk model is plotted against thermal sensations for all test conditions (114) in figure 2.3.27.

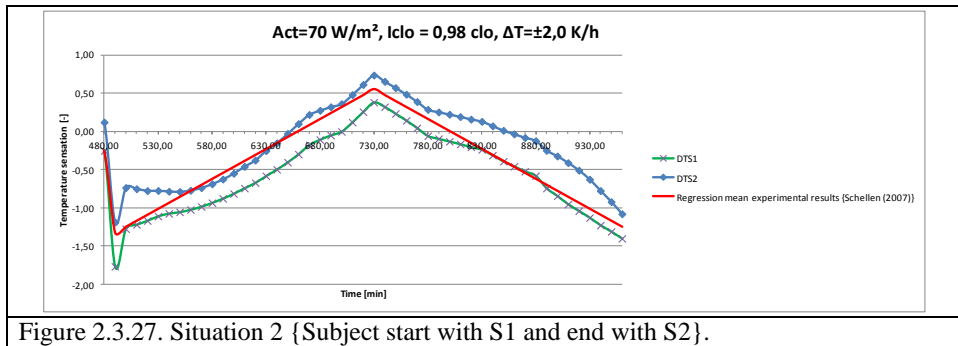

Figure 2.3.27. Situation 2 {Subject start with S1 and end with S2}.

In the study of Nevin et al. (119) a total of eleven female office workers and seven male college students participated in the experiments. The individuals were combined in three groups; each group participated on separate days. The groups were classified into five young females (22 years \pm 3 years standard deviation), six older females (44 years \pm 11 years standard deviation) and seven males (25 years \pm 4 years standard deviation). Because at the time of the experiment only four elderly females were available along with two 33-year-old females it was decided to include all six as a separate group referred to only as “older female group”. Elderly males were not available at the time of the experiments. All subjects were in good health and were paid for their participation. Each group was exposed simultaneously to a air temperature swing of \pm 0.3 K/min ($T_{air,mean} = 25^{\circ}C$, $T_{air,max}=30^{\circ}C$, $T_{air,min} = 20^{\circ}C$) during two hours. Each of the subjects rested on a plastic/aluminium legged office chair for 15 minutes and walked around the chamber at a rate of 50 steps/min for 5 minutes. The pace was kept constant by using a metronome. The activity level for the walking period for both male and female subjects was about 1.2 met, for a total of 15 minutes with a rest of 5 minutes. The mean air velocity was 0.1 m/s and relative humidity was kept constant at 50%. During the first half hour the air temperature was set at 25°C (119).

The simulated situation with the Stolwijk model is plotted against thermal sensations for the test conditions with the older females and the young males and females respectively in figure 2.3.28 and figure 2.3.29.

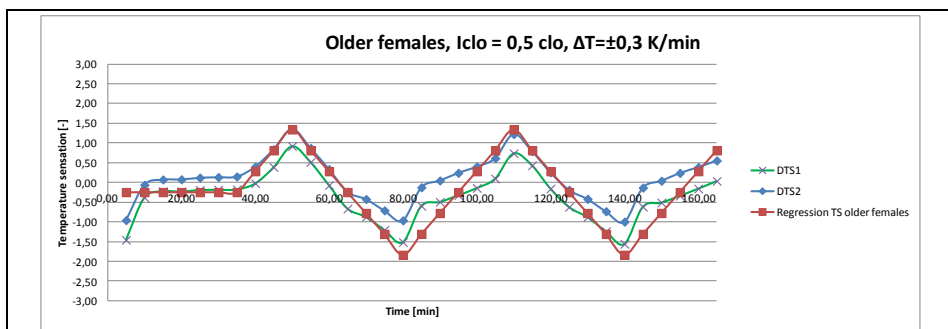

Figure 2.3.28. Simulation Stolwijk model versus regression thermal sensation older female (119).

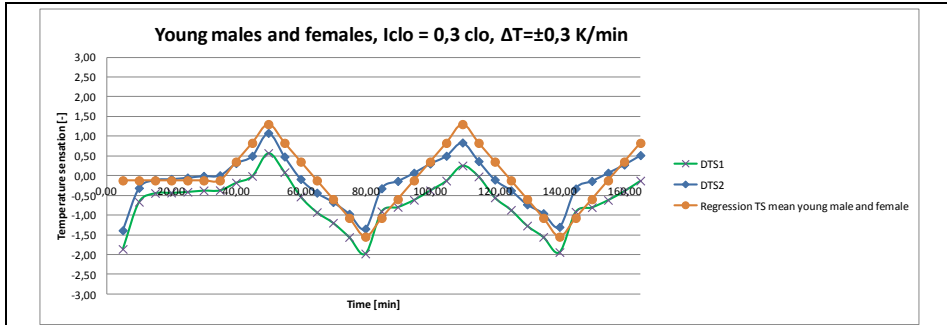

Figure 2.3.29. Simulation Stolwijk versus regression mean experimental results young males and females (119).

2.3.11 Conclusion

It is concluded on the basis of the calculations and the experimental results that:

- In general the second version of the dynamic thermal sensation (DTS2), combined with the Stolwijk model, proved to be more accurate than the first version (DTS1)
- especially in a quiet constant linear temperature decreasing situation, at the cold end of the comfort zone, the experimental results better match with the thermal sensation, according to the first version of the dynamic thermal sensation model of Fiala (DTS1), in combination with the Stolwijk model.

The Stolwijk model is more valuable by adding clothing and thermal sensation, suitable for the assessment of static and dynamic conditions, and the predicted percentage of dissatisfied. Based on on the reserach of Munir et al. (Munir, Takada, & Matsushita, 2009), an investigation on the improvemnt of the calculation of the skin temperature, the extent to which the Stolwijk model is suitable for the evaluation of local discomfort should be investigated. The Stolwijk model can, for example, be used for the assessment of individual ventilation and air conditioning systems. It is also possible to modify the Stolwijk model with individual characteristics, so the differences between subpopulations (e.g. young and old) can be assessed.

2.4 A proposal for a new model for determining the thermal sensation in a step change transient homogeneous thermal environment

ABSTRACT. This chapter examines to which extent the by Takada et al. (120) derived equation is useful for the calculation of the dynamic thermal sensation in general. Furthermore it is examined whether a more accurate model for the calculation of the thermal sensation in a step change transient thermal environment is to derive, with the use of the adjusted Stolwijk model and the data obtained in the classic experiments of Gagge, Stolwijk and Hardy (115), Gagge and Stolwijk and Saltin (121) and the recent experiments of Xiuyuan Du et al. (122) and Hong Liu et al. (123). In this comparison the DTS-model of Fiala et al. (19) is included.

Keywords

Thermal indoor environment, Thermal sensation, Transients, Human thermal model.

2.4.1 Introduction

Thermal environments in free-running buildings, in which natural ventilation is dominant, can be regarded as dynamic thermal environments. These situations cannot be evaluated by the PMV/PPD-method, according to ISO-7730 (56), (124), as is nevertheless done in most comparative studies with regard of adaptation for lack of better. With an understanding of the thermal sensation in transient thermal environments the field of study is one step closer to the solution of the problem to understand human response and thermal comfort in the ubiquitous dynamic thermal environment. The understanding of the human response and thermal comfort in the transient thermal environment ought to be a common research goal within the field of study (124).

The previous chapter in the thesis shows that the dynamic thermal sensation (DTS), as published by Fiala (112), and Fiala et al. (19), combined with the here adapted Stolwijk model, at sedentary activities, is in reasonably good agreement with the research results of the known experiments in the literature. In particular, the second version of the dynamic thermal sensation, such as published in Fiala et al. (19), generally exhibit the best impression in relation to the above mentioned experiments.

For the Predicted Mean Vote (PMV) for instance, as an index for steady state the predicted thermal sensation in the steady state can be calculated directly from the given thermal environmental conditions. For the transient state however it is necessary to divide the processes into two parts. When experimental thermophysiological responses are available based on measurements, one is able to build a model to predict thermal sensation from the thermophysiological responses. If the experimental physiological responses are not available as measured data, it is possible to obtain them from a human thermal model, though a possible error in the model (65), (103) will be mixed in the prediction of the thermal sensation. Some models for predicting transient thermal sensation based on thermophysiological responses have been proposed in the literature. Wang (125) for instance proposed a regression model based on the skin temperature and the heat storage of the human body. The simulation of reality with this model leaves much to be desired, according to Jones (126). Fiala et al. (19) presented regression equations based on the mean skin temperature and its time differential and core temperature (see chapter 2.3.4 in this thesis). Zhang et al. (127), (128), (129) proposed a model for predicting the local sensation of individual body parts and the whole-body thermal sensation in non-uniform transient environments by using the mean and local skin temperatures, their time differential, and the time differential of the core temperature. The necessity of considering the core temperature or its time differential as an explanatory variable for the transient thermal sensation is not clearly indicated in these studies (120).

At present for the calculation of the whole-body thermal sensation in homogenous transient thermal environments there seems to be no better model yet than the DTS-model as derived by Fiala et al. (19). In Takada et al. (120), however, an alternative method is proposed in order to derive another mathematical description of the thermal sensation in homogenous step change transient thermal environments. Like Fiala (112) also Takada et al. (120) used a (non-) linear multiple regression analysis, based on experimental research, to derive mathematical relationships. Fiala, for example, has attempted to decompose the dynamic thermal sensation in a triad of components for which each influence a mathematical relationship is being derived, such as extensively described in the thesis of Fiala (112). Takada et al. (120) have this trouble avoided by gathering all influences in an additive of Lorentzian cumulative functions for the measured skin temperature and the measured differential of this temperature. In the publication of Takada et al. (120) an equation is displayed with which the dynamic thermal

sensation can be calculated within the framework of the measurements conducted by them. This chapter examines to which extent the by Takada et al. (120) derived equation is useful for the calculation of the dynamic thermal sensation in general. Furthermore it is examined whether a more accurate model for the calculation of the thermal sensation in a step change transient thermal environment is to derive, with the use of the adjusted Stolwijk model and the data obtained in the classic experiments of Gagge, Stolwijk and Hardy (115), Gagge and Stolwijk and Saltin (121) and the recent experiments of Xiuyuan Du et al. (122) and Hong Liu et al. (123). In this comparison the DTS-model of Fiala et al. (19) is included.

2.4.2 Research Takada et al. (120)

This study attempts to build and validate an equation that explains whole-body thermal sensation in the non-steady state based on only the mean skin temperature and its time differential, namely:

$$TS = a_0 + a_1 * (0.5 + \text{Arctan}((T_{sk} - a_2)/a_3)/\pi) + b_1 * (0.5 + \text{Arctan}((dT_{sk}/dt - b_2)/b_3)/\pi)$$

Herein is:

- TS = whole-body thermal sensation, according to the seven-point ASHRAE thermal sensation scale (-3 cold to 3 hot)
- π = 3.14159
- T_{sk} = mean skin temperature [°C]
- dT_{sk}/dt = time differential of the mean skin temperature [°C/min]
- a_1 - b_3 = coefficients [-].

This approach relies on nonlinear regression and uses the data obtained in three types of experiments on various types of thermally transient exposure in a sedentary condition. By showing the agreement between the thermal sensation votes from the experimental data and the data calculated by the proposed equation, which is an additive of Lorentzian cumulative functions, successfully predicted thermal sensation in the non-steady state for sedentary conditions in a thermally homogeneous environment. The validity of the proposed equation for the condition was also shown through field experiments, which included not only sedentary conditions in an thermally homogeneous environment but also walking processes and situations in which the subjects were exposed to inhomogeneous environments such as non-airconditioned rooms and outdoor spaces. The proposed equation was shown to predict the trend of thermal sensation vote for not only sedentary conditions in thermally homogeneous environments but also light exercise activities in inhomogeneous environments, unless the direction of the change (i.e., increase or decrease) in the local skin temperatures between body segments did not differ significantly. In this study, the core temperature was not studied as a parameter for explaining the thermal sensation; at this moment, it is not possible to completely deny the contribution of core temperature to thermal sensation in the non-steady state. However, it was shown that the equation as a function of mean skin temperature and its time differential can be used for many situations that appear in the everyday scenes encountered in human living (120).

2.4.3 Application of the proposal of Takada et al. (120)

In order to determine whether it is possible to derive a reliable alternative equation for the dynamic thermal sensation in combination with the adjusted Stolwijk model (see chapter 2.3.4 in this thesis), four experimental studies on thermal sensation among step-change transient environments are used for this. One of these studies are the experiments of Gagge, Stolwijk and Hardy (115), also used by Fiala in his dissertation (112) for the derivation of the DTS

model, and recent experimental studies of Xiuyuan Du et al. (122) and Hong Liu et al. (123) which connect well with the experiments of Gagge, Stolwijk and Hardy (115). In addition the experiments of Gagge, Stolwijk and Saltin (121) are used because in these experiments the subjects were exposed to various transient thermal environments at different levels of physical activity (3 - 9 met) instead of the sedentary activity (0.8 - 1 met) in the aforementioned experiments.

Research Gagge, Stolwijk and Hardy (115)

During the experiments of Gagge et al. (11), three male subjects (22-24 years old) who were exposed for one hour in an environment of 29°C and then quickly transferred to a room at 17.5°C for 2 hours. At 180 minutes, the subjects moved back into the room at 29°C for one hour. Complete heat balances were measured by partitioned calorimetry each 5 minutes, and readings were made of rectal, tympanic, and mean skin temperatures, weight loss, metabolic rate, ambient temperature, relative humidity, and air movement, as well as heart rate. Insensible heat loss by evaporation and metabolic rate during the 4-hour period was essentially constant at minimal levels. A similar experiment for a warm transient was executed with three subjects exposed for one hour at a neutral temperature of 28°C and then quickly transferred to a hot environment at 48°C for 2 hours; the subjects were transferred quickly back to the neutral environment, 28°C, for the final hour (115).

Research Gagge, Stolwijk and Saltin (121)

Four young men (22-32 years old) were exposed to various transient thermal conditions at different levels of activity. The routine experimental protocol was generally as follows: After 30 minutes of bed rest in a thermally neutral room (26-28°C), the subject, dressed in shorts, socks, and rubber shoes, entered the test chamber and took his seat on the bicycle. Test Measurements and exercise began within 5 minutes. The two lowest work loads (approximately 40 minutes each) were performed usually in sequence during the same experimental period. The heaviest work load was performed on a separate day. From the start of the experiment category estimates of sensation (7-point scale) were recorded simultaneously with each skin temperature measurement. This occurred at 7-10 minutes intervals till the end of the experiment. Sweat rate measurements were observed after 20-minute intervals during a short (2-minute) rest period. In the present experimental series on exercise at three work levels (25%, 50% and 75% maximal oxygen uptake) and three temperature levels (10°C, 20°C and 30°C, 30-40% RH, 0.20-0.25 m/s), or under nine different combinations, a total of 72 experimental runs were performed on the four subjects. At least one experimental run at each condition was performed on each of the four subjects (121).

Research Xiuyuan Du et al. (122)

This paper reports on studies of the effect of temperature step-change (between a cool and a neutral environment) on human thermal sensation and skin temperature. Experiments with three temperature conditions were carried out in a climate chamber during the period in winter. Twelve male subjects (age: 20-30 years) participated in the experiments simulating moving inside and outside of rooms or cabins with air conditioning. Skin temperatures and thermal sensation were recorded. Results showed overshoot and asymmetry of the thermal sensation vote due to the step-change. Skin temperature changed immediately when subjects entered a new environment. When moving into a neutral environment from cool, dynamic thermal sensation was in the thermal comfort zone and overshoot was not obvious. Air-conditioning in a transitional area should be considered to limit temperature difference to not more than 5°C to decrease the unacceptability of temperature step-change. The linear relationship between thermal sensation and skin temperature or gradient of skin temperature does not apply in a step-change environment. Different cool conditions (12-15 and 17°C; air veloci-

ty < 0,1 m/s; RH ≈ 54-58%) were created in the climate chamber (4m*3m*2.7m, Room 1, and a neutral environment (22°C; air velocity < 0,1 m/s; RH ≈ 44-51%) was created by air-conditioning in next door observing room (4m*3m*2.7m, Room 2), both of which could be individually controlled for environmental variables. A typical uniform clothing combination (1.17 clo) was adopted for subjects to avoid the effect of difference in clothing insulation. During the experiment, the sedentary subjects could read newspapers and magazines ($M = 1$ met) (122).

Research Hong Liu et al. (123)

Experiments were conducted in a climate chamber (Room 1, 4m*3m*2.7 m) and an adjacent air-conditioning room (Room 2, 4m*3 m*2.9 m) with a door connecting them. The environmental variables for these two rooms can be individually controlled. The climate chamber was used to create three temperatures, 32°C, 30°C, 28°C which were selected to represent the ambient temperatures that occur in the warm seasons, while the air-conditioning room was used to maintain a neutral one of 25°C. The temperature differences between the two rooms are 7 K, 5 K, and 3 K, respectively. The relative humidity (RH) in both rooms were controlled to be approximately 60% and air velocity was less than 0.1 m/s. A total of 20 healthy male college students ranging in age from 22 years to 25 years participated in the experiments. All the students were not currently taking prescription medication and had no history of cardiovascular disease. Subjects were asked to avoid caffeine, alcohol, and intense physical activity at least 12 h prior to tests. Each subject provided his or her basic information (e.g., age, height, weight) prior to the tests, and participated voluntarily in all three tests. They were briefed on the purpose of the tests, were familiar with experimental procedures and were trained to know the test procedure well. During the experiment period, they were required to wear a uniform clothing including short-sleeved T-shirt, short trousers and sock with an insulation level of 0.5 clo (1clo = 0.155 m² K/W) referenced from clothing garment checklists in ASHRAE Standard 55. All experiments were conducted in summer from June to July in 2012, but not immediately after breakfast or lunch. Each test experience lasted for 2 h. In each test, the subject arrived at Room 2 and rested for about 20 min, then entered the climate chamber (Room 1) and put on uniform clothing. Before the beginning of the experiment, subjects were given sedentary activities (reading) for 30 min for acclimation to the thermal environment and keep the metabolism stable. The thermal sensation survey and skin temperature measurements were performed simultaneously. Subjects were asked to report their perception in a questionnaire every 10 min. After 30 min, the subjects moved into the cooler chamber (Room 2). The subjects voted for their thermal sensation immediately after entering Room 2. Next, the subjects completed a 60-min test in Room 2 where they voted for their thermal sensation every 2 min in the early 10 min and then every 10 min for the rest 50 min. Finally, the subjects returned back to Room 1 remaining for 30 min. In the final 30 min, they voted every 2 min in the early 10 min and every 10 min for the rest 20 min. The skin temperature was recorded every minute in the whole test (123).

2.4.4 Method and result

The environmental conditions and individual parameters of each experiment are used in the adjusted Stolwijk model. With the above assumptions each experiment is recalculated with the Stolwijk model. In the situations with high metabolisms the mechanical efficiency is taken into account, according to ISSO-researchreport 5 (130). The calculated hypothalamic temperature, skin temperature and their differential, together with the experimentally determined thermal sensation for all experiments are used for non-linear regression analysis, on the basis of an additive of Lorentzian cumulative functions. The in this way derived new model for the prediction to temperature step-change and the response of whole-body transient thermal sensation reads as follows:

TTS-Model

$$TTS = 3 * \tanh(a_0 + a_1 * (0.5 + \text{Arctan}((\Delta T_{sk} - a_2)/a_3)/\pi)) + b_1 * (0.5 + \text{Arctan}((dT_{hyp}/dt - b_2)/b_3)/\pi) + c_1 * (0.5 + \text{Arctan}((dT_{sk}/dt - c_2)/c_3)/\pi) + d_1 * (0.5 + \text{Arctan}((\Delta T_{hyp} - d_2)/d_3)/\pi)$$

Herein is:

- TTS = whole-body transient thermal sensation, according to the seven-point ASHRAE thermal sensation scale (-3 cold to 3 hot)
- π = 3.14159
- T_{sk} = mean skin temperature [°C]
- ΔT_{sk} = ($T_{skin} - 34.4$) [K]
- ΔT_{hyp} = (Thyothalamic-37) [K]
- dT_{sk}/dt = time differential of the mean skin temperature [°C/min]
- dT_{hyp}/dt = time differential of the hypothalamic temperature [°C/min].

The preliminary coefficients of the model are displayed in Table 2.4.1.

Table 2.4.1. Preliminary coefficients of the TTS-model.

Activity [met]	$\Delta T_{sk} < 0$ [K]	$\Delta T_{sk} \geq 0$ [K]	$dT_{sk}/dt < 0$ [K/min]	$dT_{sk}/dt \geq 0$ [K/min]
Sedentary [0.8-1.0]	a0 = -2.063588 a1 = 9.982887 a2 = -1.872745 a3 = 13.81587	a0 = 3.352346 a1 = 1.072634 a2 = 0.42778 a3 = 0.089753	c1 = 3.27785 c2 = 0.04048 c3 = 0.018565	c1 = 0.780937 c2 = 0.001583 c3 = 0.030654
Physical [3.0-9.0]	a0 = -8.246002 a1 = 1.644913 a2 = -1.267434 a3 = 0.471258	a0 = -8.792261 a1 = 5.210176 a2 = 0.606483 a3 = 1.286529	c1 = 8.174161 c2 = -0.897781 c3 = 0.397515	c1 = 12.16729 c2 = -6.632809 c3 = 23.69986
Mean of both	a0 = -30.38835 a1 = 26.28107 a2 = 1.38932 a3 = 37.47551	a0 = -28.55317 a1 = 13.94224 a2 = -3.349546 a3 = 2.584304	c1 = 67.29822 c2 = 3.106636 c3 = 5.232534	c1 = 39.7846 c2 = -5.659669 c3 = 29.16001
	ΔT_{hyp} [K]		dT_{hyp}/dt [K/min]	
Sedentary [0.8-1.0]	b1 = -0.469034 b2 = 0.006125 b3 = 0.00000461		d1 = -4.494957 d2 = -2.481599 d3 = 1.368073	
Physical [3.0-9.0]	b1 = 0.143838 b2 = 0.028509 b3 = 0.000000203		d1 = -14.77825 d2 = 11.37101 d3 = 16.96701	
Mean of both	b1 = 0.301446 b2 = 0.025319 b3 = 0.00000129		d1 = -1.501634 d2 = 1.310154 d3 = 0.138942	

2.4.5 Comparison of the calculation results and the experimental results

The calculation results ($TTS_{\text{mean of both}}$) versus the experimental results, with regard of only the sedentary activity, and the equation of Takada et al. (120) are displayed graphically in Figure 2.4.1.

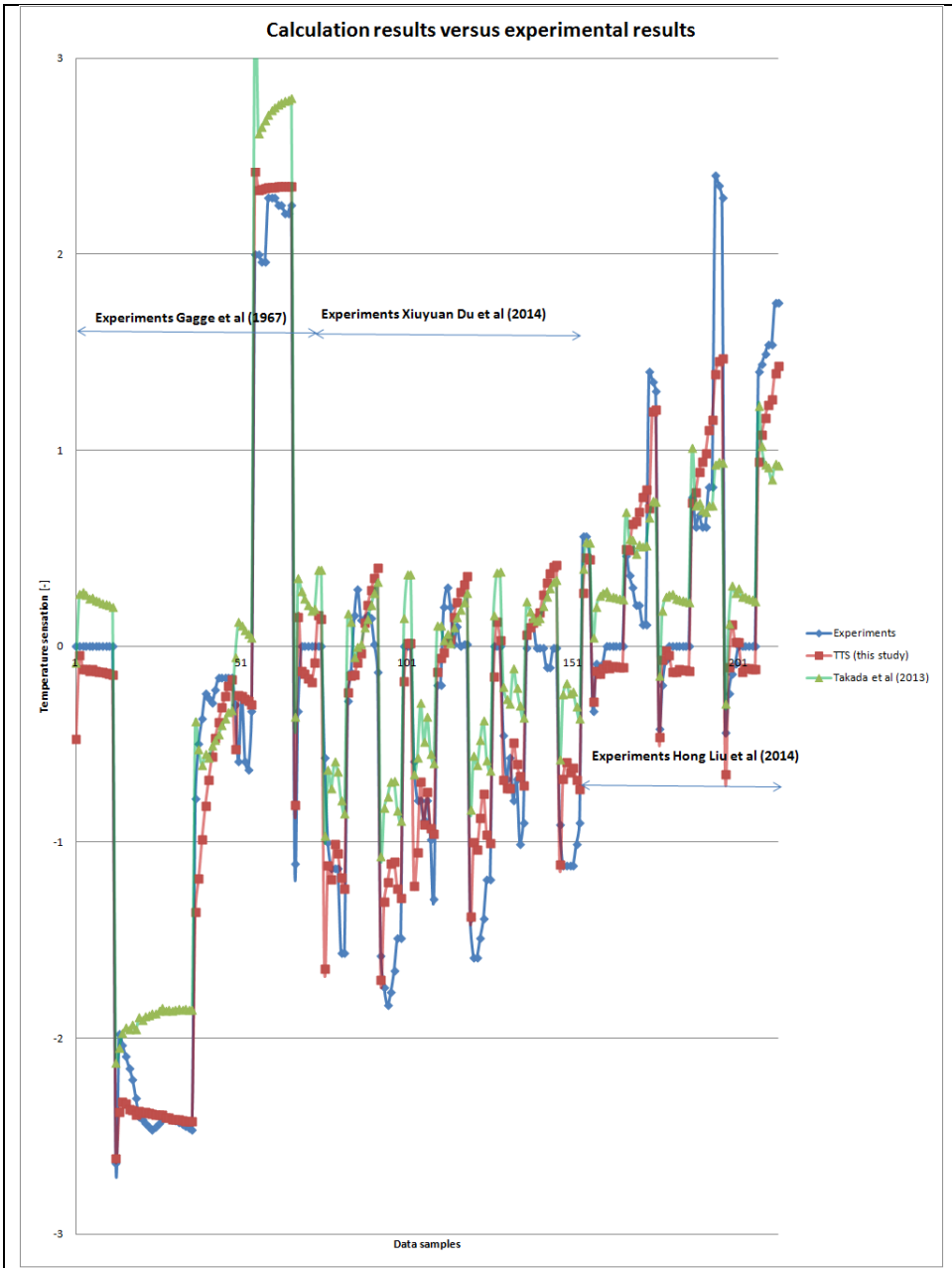

Figure 2.4.1. Calculation results ($TTS_{\text{mean of both}}$) versus experimental results (sedentary activity) and the equation of Takada et al. (120).

The calculation results (mean of both) versus all experimental results, with regard of the sedentary and the physical activity, and the DTS-model of Fiala et al. (19) are displayed graphically in Figure 2.4.2.

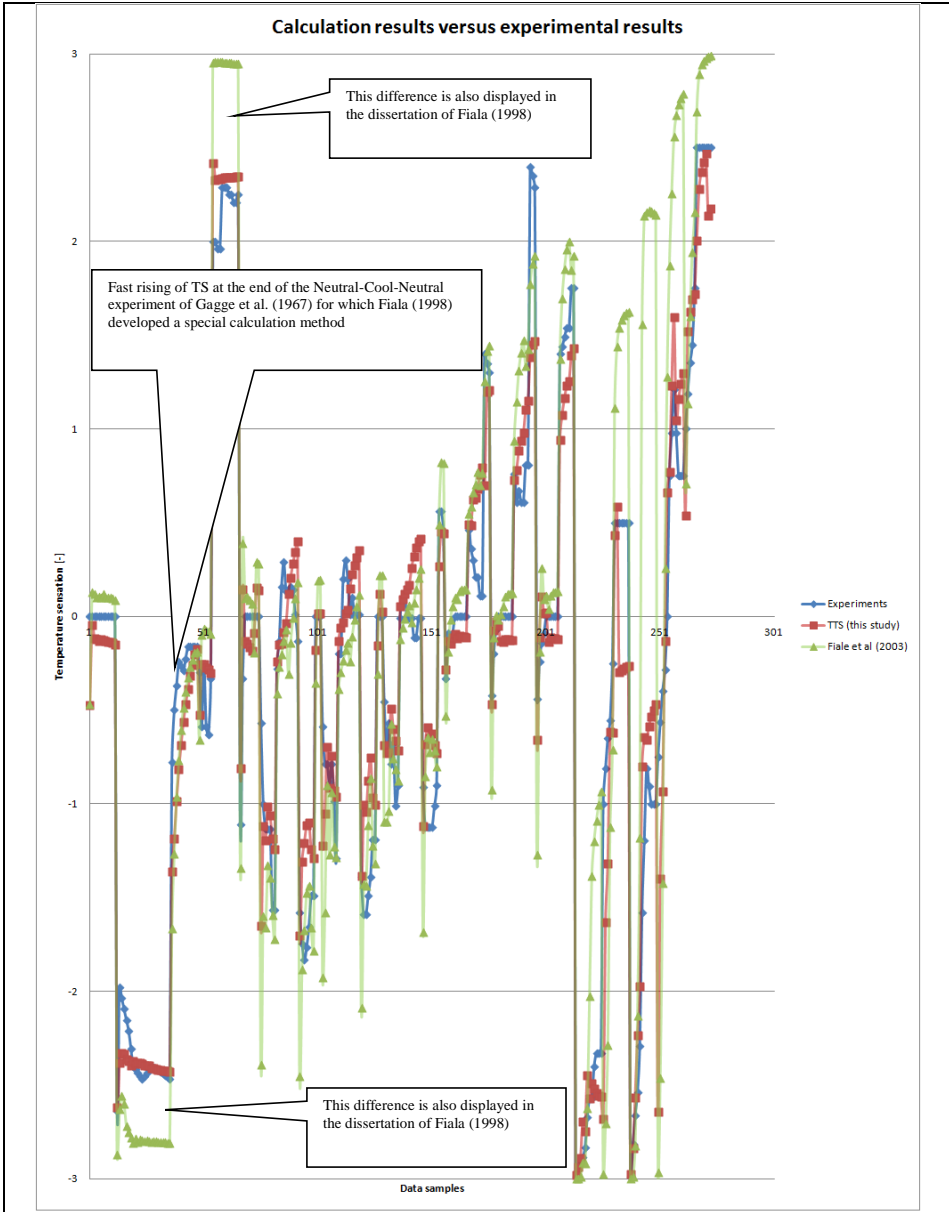

Figure 2.4.2. Calculation results ($TTS_{\text{mean of both}}$) versus experimental results (sedentary and physical activity) and the DTS-model of Fiala et al. (19).

The mean deviation and correlation coefficient of two thermal sensation models, with regard of all the experiments (sedentary and physical activity), are displayed in Table 2.4.2.

Table 2.4.2. Survey of the mean deviation and correlation coefficient (R) with regard of all the experiments (sedentary and physical activity).

Thermal sensation model	Mean deviation [-]	R [-]	R ² [-]
Fiala et al. (2003)	0,781	0,888	0,789
TTS _{mean of both} (this study)	0,361	0,962	0,925

The calculation results (TTS_{sedentary}) versus the experimental results, with regard of only the sedentary activity, and the DTS-model of Fiala et al. (19) are displayed graphically in Figure 2.4.3.

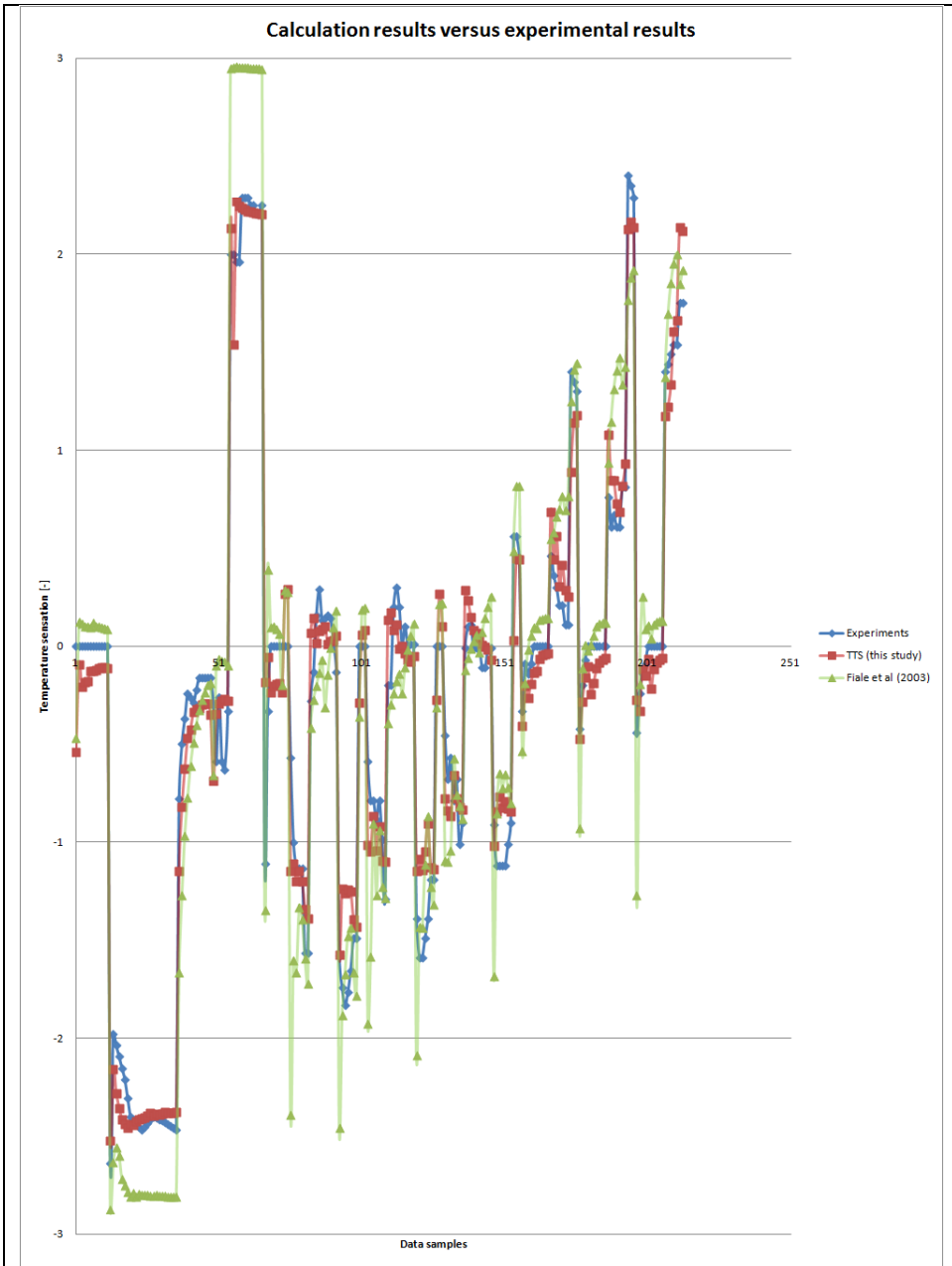

Figure 2.4.3. Calculation results ($TTS_{\text{sedentary}}$) versus experimental results (sedentary) and the DTS-model of Fiala et al. (19).

The mean deviation and correlation coefficient of three thermal sensation models, with regard of the experiments concerning the sedentary activity, are displayed in Table 2.4.3.

Table 2.4.3. Survey of the mean deviation and correlation coefficient (R) with regard of the experiments (sedentary activity).

Thermal sensation model	Mean deviation [-]	R [-]	R ² [-]
Takada et al. (2013)	0,490	0,937	0,878
Fiala et al. (2003)	0,416	0,967	0,935
TTS _{sedentary} (this study)	0,218	0,982	0,964

The calculation results (TTS_{physical}; light blue line) versus the experimental results (green line), with regard of different levels of physical activity, are displayed graphically in the figures 2.4.4 – 2.4.8. For comparison, also the calculation results of the DTS model in combination with the thermophysiological IESD-Fiala model (version 3.0), are shown in the figures (red line). The dark blue line represents the calculation results of the DTS-model (second version) of Fiala et al. in combination with the thermophysiological model of Stolwijk.

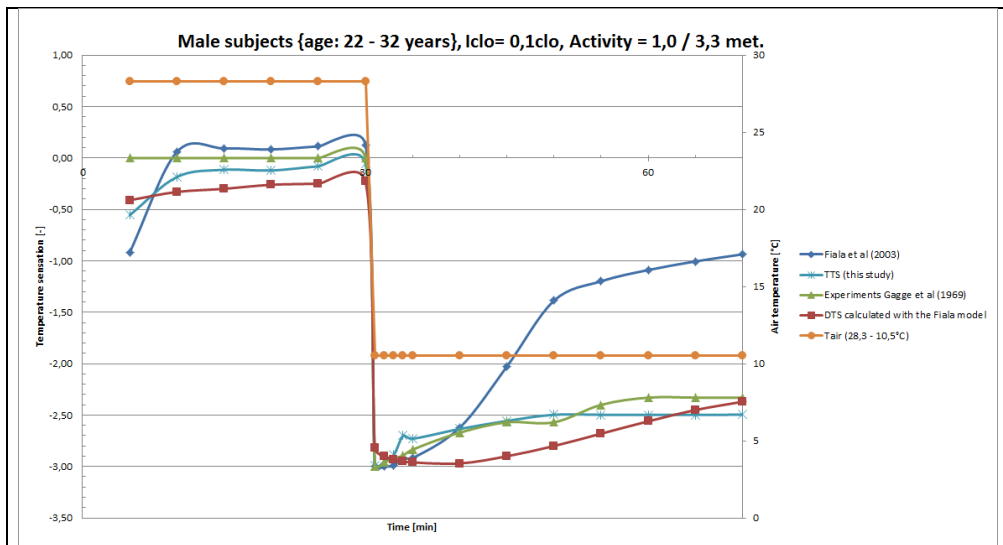

Figure 2.4.4. Calculation results (TTS_{physical}) versus experimental results and the DTS-model of Fiala et al. (19) in combination with the Stolwijk model (dark blue line) and the DTS calculated with the Fiala human model (red line). T_{air} : 28.3-10.5°C; Activity: 1,0-3,3 met.

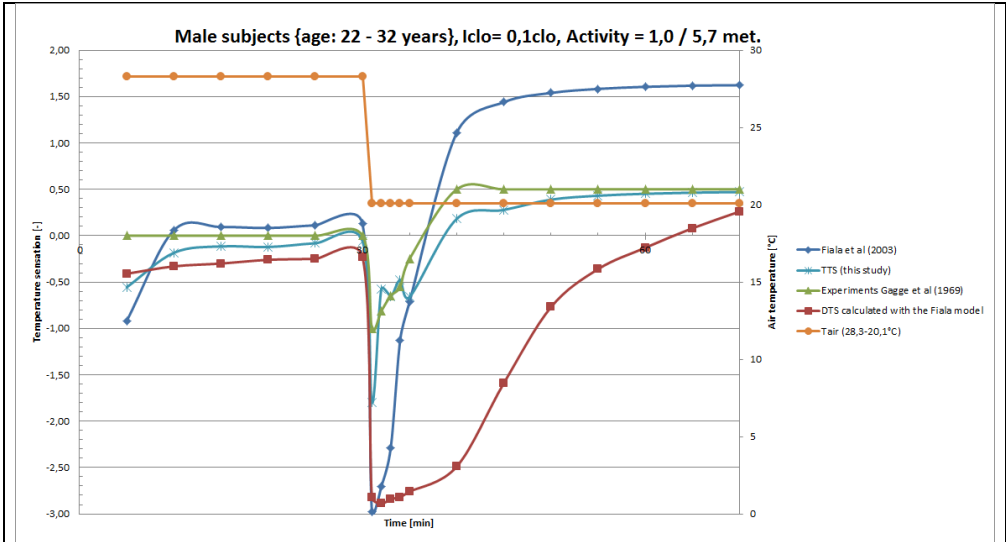

Figure 2.4.5. Calculation results (TTS_{physical}) versus experimental results and the DTS-model of Fiala et al. (19) in combination with the Stolwijk model (dark blue line) and the DTS calculated with the Fiala human model (red line). $T_{\text{air}} : 28.3-20.1^{\circ}\text{C}$; Activity: 1,0-5,7 met.

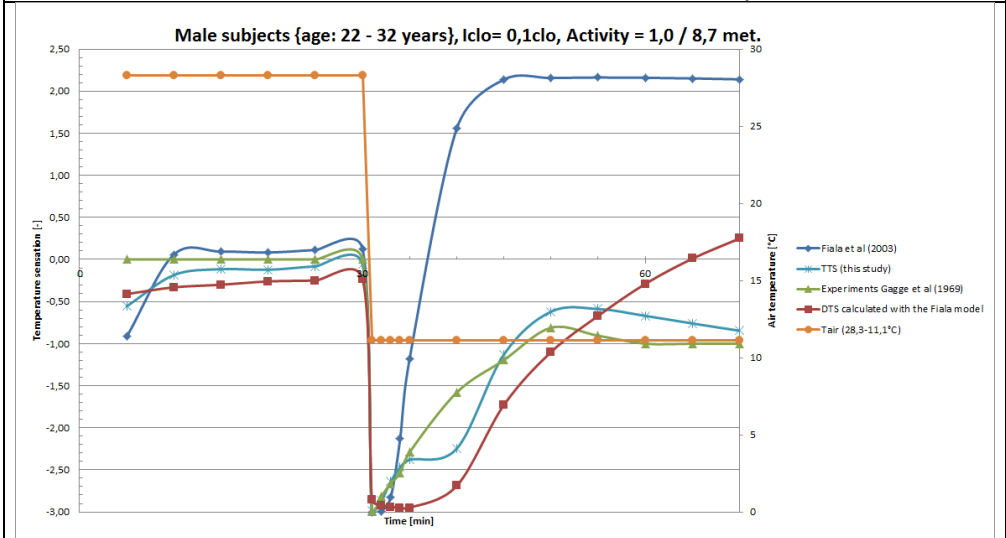

Figure 2.4.6. Calculation results (TTS_{physical}) versus experimental results and the DTS-model of Fiala et al. (19) in combination with the Stolwijk model (dark blue line) and the DTS calculated with the Fiala human model (red line). $T_{\text{air}} : 28.3-11.1^{\circ}\text{C}$; Activity: 1,0-8,7 met.

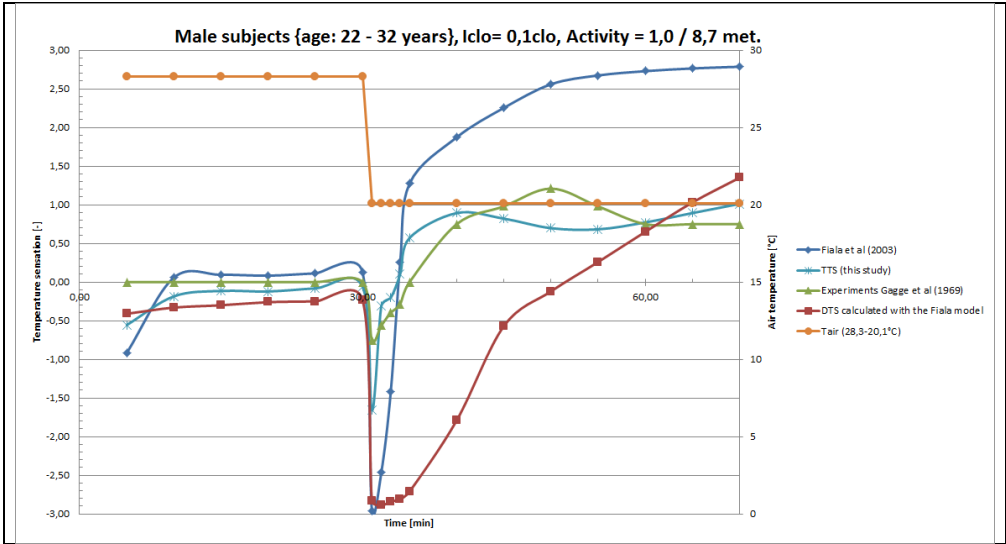

Figure 2.4.7. Calculation results (TTS_{physical}) versus experimental results and the DTS-model of Fiala et al. (19) in combination with the Stolwijk model (dark blue line) and the DTS calculated with the Fiala human model (red line). T_{air} : 28.3-20.1°C; Activity: 1,0-8,7 met.

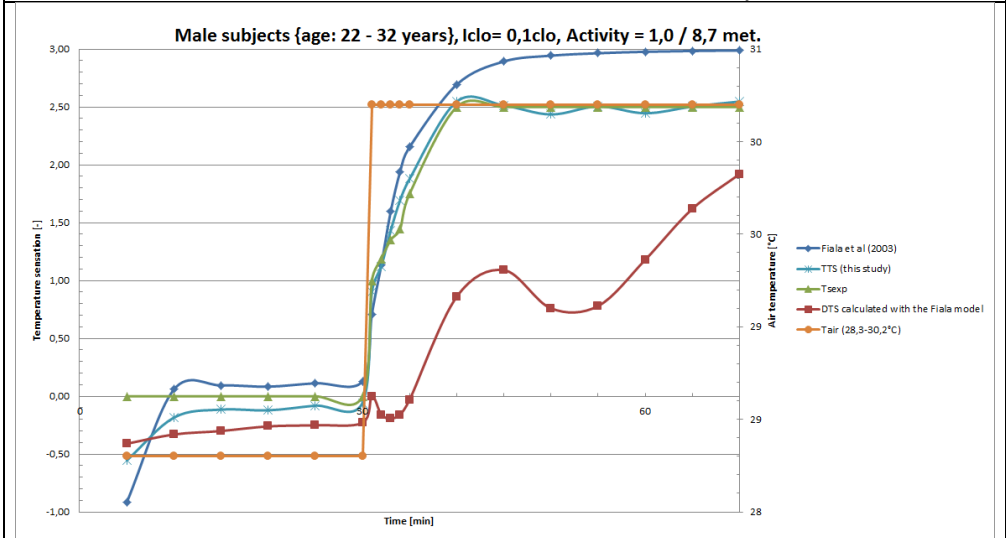

Figure 2.4.8. Calculation results (TTS_{physical}) versus experimental results and the DTS-model of Fiala et al. (19) in combination with the Stolwijk model (dark blue line) and the DTS calculated with the Fiala human model (red line). T_{air} : 28.3-30.2°C; Activity: 1,0-8,7 met.

2.4.6 Application and improvement of the TTS-model

In order to determine to which extent the TTS-model, derived on the basis of only a limited number of experiments as described above, is already suitable for the calculation of the thermal sensation in other experiments, use is made of the research of Goto et al. (131).

This study investigated the effect on thermal perception and thermophysiological variables of controlled metabolic excursions of various intensities and durations. Twenty-four subjects were alternately seated on a chair or exercised by walking on a treadmill at a temperature predicted to be neutral at sedentary activity. In a second experimental series, subjects alternated between rest and exercise as well as between exercise at different intensities at two temperature levels. Measurements comprised skin and oesophageal temperatures, heart rate and subjective responses. Thermal sensation started to rise or decline immediately (within 1 min) after a change of activity, which means that even moderate activity changes of short duration affect thermal perceptions of humans. After approximately 15–20 min under constant activity, subjective thermal responses approximated the steady-state response. The sensitivity of thermal sensation to changes in core temperature was higher for activity down-steps than for up-steps. The current study comprised two stages. In the first, subjects were alternately seated on a chair or exercised by walking on a treadmill at a temperature predicted to be neutral at sedentary activity. In the second stage, subjects alternated between rest and exercise as well as between exercise at different intensities. Different subjects were used in the two stages. In the present study, relative work load (RW) was determined as the ratio of the heart rate recorded at each exercise intensity to the maximal heart rate. The heart rate of a subject resting on a chair corresponded to 0% work load while 100% corresponded to a subject exercising at their own maximal intensity. For each subject, the metabolic rate was approximated with the measured heart rate as input to a linear interpolation between the heart rate at sedentary activity, at which metabolic rate (M) was assumed constant at 58.2 W/m², and the heart rate recorded at the maximum work load at each subject's maximum oxygen consumption (131).

Stage 1 experiments

In each experimental session, subjects were randomly assigned to three exercise bouts used to study decay of metabolic heat and one bout for the study of accumulation of heat. The duration of the accumulation phase was held constant at 30 min and it was always the final bout of exercise performed during a session. All exercise took place on a treadmill. Between bouts of exercise, subjects performed sedentary work (reading, writing). Twenty-four subjects (12 female and 12 male) participated as volunteers. They were mostly university students and were paid for their participation. It was intended that each subject should participate in three experimental sessions, but subjective responses were recorded from only 22 of the subjects for all experimental conditions. During the experiments, subjects wore a standard uniform consisting of a thin, long-sleeve cotton shirt, trousers and their own underwear. The clothing insulation of this ensemble was around 0.7 clo, including chair insulation (0.08 clo), as measured by a seated thermal manikin. All experiments were carried out in a climate chamber at the International Centre for Indoor Environment and Energy, Technical University of Denmark. In the chamber, mean radiant temperature was equal to air temperature and the air velocity was low (<0.1 m/s). All experiments in this stage were conducted at a temperature of 26°C. The relative humidity was not controlled, and varied in the range between 15% and 50% between experimental sessions. There was only negligible variation of rh within sessions. Each experiment commenced with subjects getting dressed in the uniforms and attaching the heart rate sensor to their chest before entering the chamber. During the first 30 min of an experiment, subjects adapted to the environment at sedentary activity before starting the first bout of walking activity. During the rest periods, subjects answered questions regarding thermal sensation on a 9-point scale (ASHRAE 7-pt scale with very hot and very cold added as end points), thermal comfort, thermal acceptability, and temperature preference every minute during the first 6 min after the metabolic step-change and every 3rd minute during the remaining period. During the walking period of the accumulation phase, subjects answered only one question

regarding their thermal sensation. Skin temperature was measured on 12 subjects at nine points (forehead, chest, back, anterior thigh, posterior thigh, shin, calf, upper arm, hand). Oesophageal temperature was measured on six subjects with a copper-constantan thermocouple with silicone tube, which had an accuracy of $\pm 0.1^{\circ}\text{C}$ (131).

Stage 2 experiments

The stage 2 experiments were designed to investigate whether the rate of change of thermal sensation was affected by ambient temperature. Also, the experiments were performed to investigate human response to metabolic step changes between different exercise intensities as well as between rest and exercise. Twenty-four subjects (12 female and 12 male) participated as volunteers. Each subject participated in only one experimental session. The experimental uniform was the same as in the stage 1 experiments. In a random, but balanced, order subjects were assigned to three exercise bouts to study accumulation and decay of metabolic heat at a temperature of 21°C . The exercise intensities were 20%, 40% and 60% RW, and the exercise durations were 15 min. After these exercise bouts, subjects entered an adjacent climate chamber, held at 26°C , and were assigned to three successive exercise intensities, which were increased from 20% to 60% and back to 20% RW. The exercise at each intensity had a duration of 9 min and the treadmill speed was changed within 1 min between each 9-min period at constant intensity. This part of an experimental session was conducted at a temperature of 26°C . Between bouts of exercise, subjects performed sedentary work (reading, writing). Two adjacent and interconnecting chambers (5 and 6) accommodated the experiments. The temperature of chamber 5 was 21°C , and that of chamber 6 was 26°C . The relative humidity of chamber 5 varied in the range between 20% and 60%, and that of chamber 6 varied in the range between 15% and 45%. Each experiment commenced with subjects getting dressed in the uniforms and attaching the heart rate sensor to their chest before entering chamber 5. During the first 30 min, subjects adapted to the environment at sedentary activity before starting the first bout of walking activity. After three walking periods and three rest periods, subjects were asked to enter chamber 6. Subjects then started the successive exercise series after 20–40 min of adaptation to the environment at sedentary activity (131).

Calculation results

The calculation results of the TTS-model and the DTS-model (second version) in combination with the Stolwijk model versus the experimental results of Goto et al. (131) are displayed graphically in the figures 2.4.9 – 2.4.14.

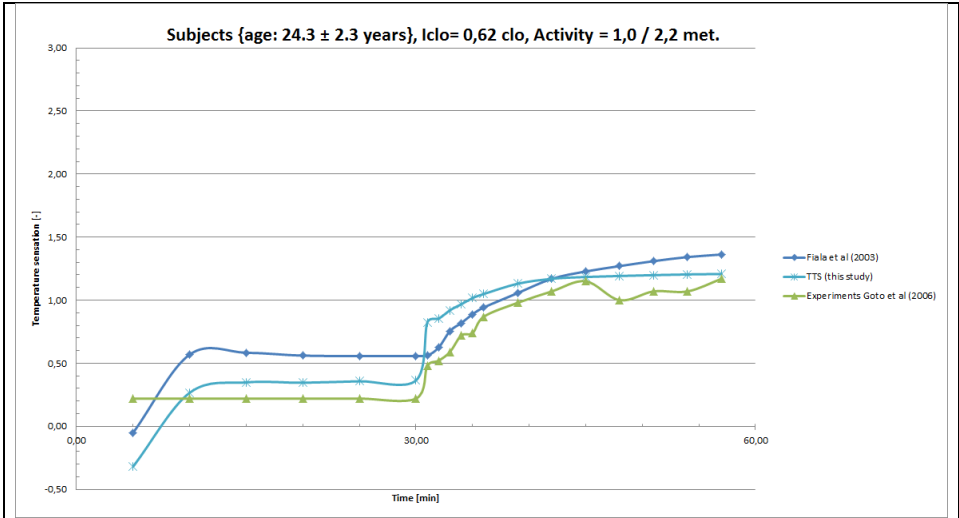

Figure 2.4.9. Average thermal sensation after an up-step of exercise (20% RW) in stage 1 experiment.

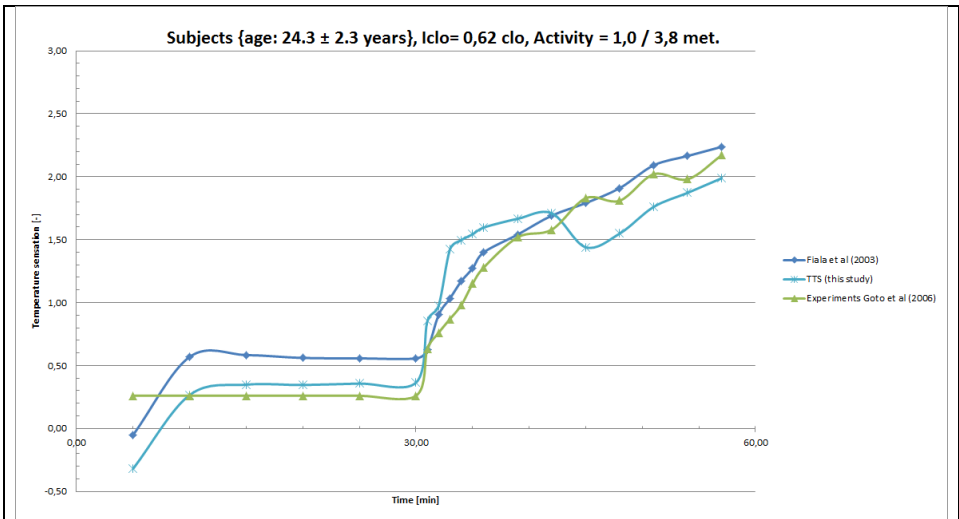

Figure 2.4.10. Average thermal sensation after an up-step of exercise (40% RW) in stage 1 experiment.

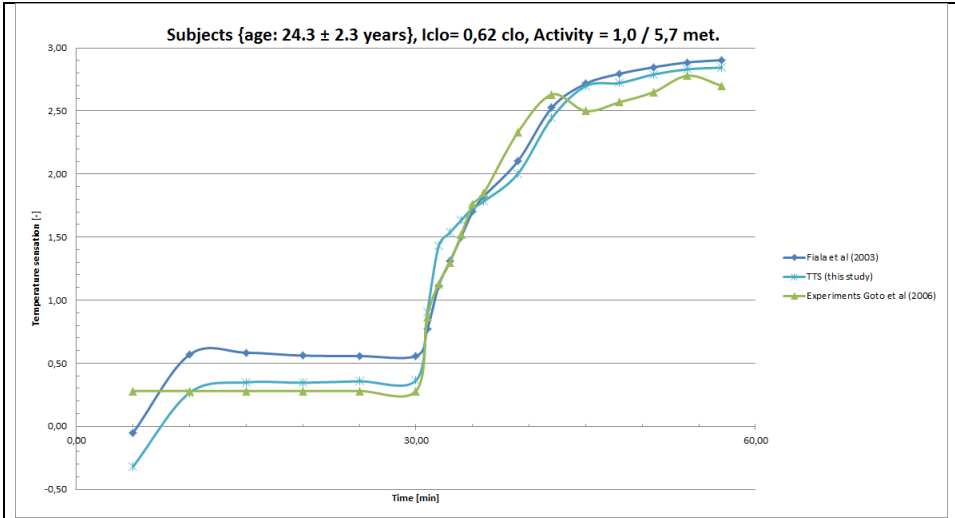

Figure 2.4.11. Average thermal sensation after an up-step of exercise (60% RW) in stage 1 experiment.

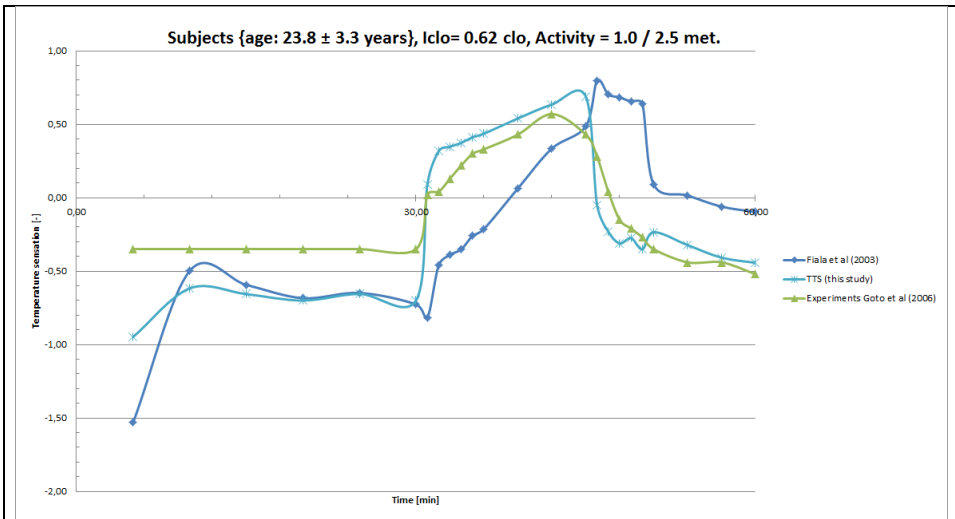

Figure 2.4.12. Average thermal sensation with metabolic step-changes (0-20-0% RW) at 21°C of stage 2 experiment.

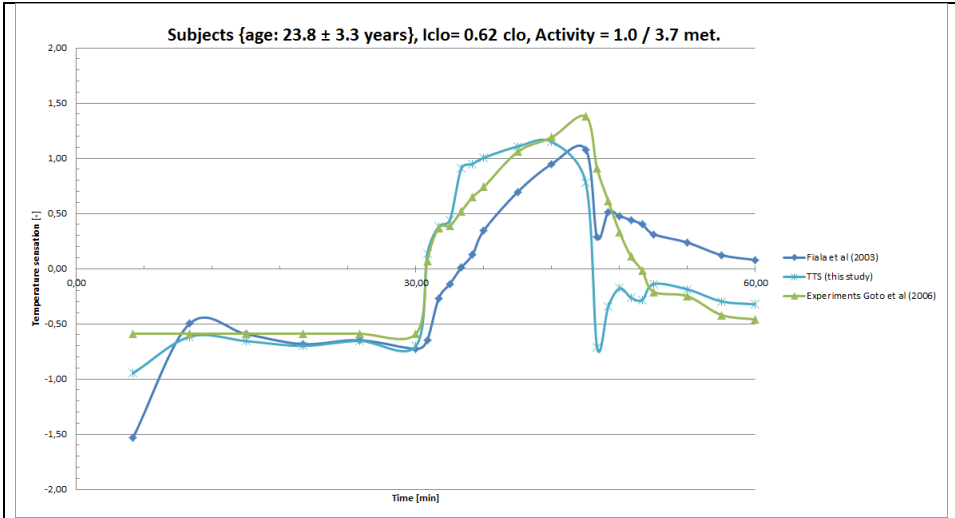

Figure 2.4.13. Average thermal sensation with metabolic step-changes (0-40-0% RW) at 21°C of stage 2 experiment.

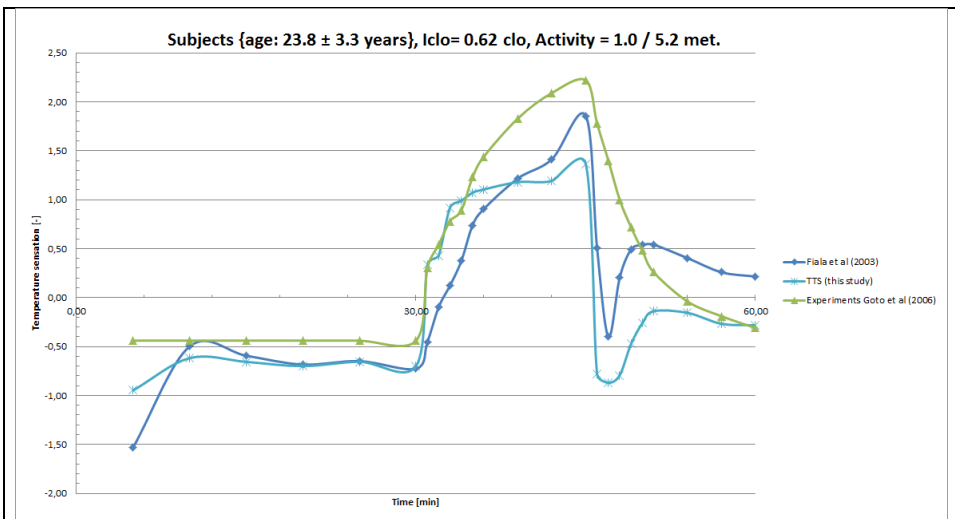

Figure 2.4.14. Average thermal sensation with metabolic step-changes (0-60-0% RW) at 21°C of stage 2 experiment

The calculation results in Figures 2.4.13 and 2.4.14 show that within a decrease of metabolism there is a calculated undershoot of the thermal sensation which in reality doesn't occur. This indicates that the above situation is not known within the TTS-model. It is therefore advisable to use the experiments of Goto et al. (131) too in the derivation of coefficients in the TTS model. When the research results of Goto et al. (131) are included too in the derivation of the coefficients in the model than the adjusted coefficients are as displayed in Table 2.4.4.

Table 2.4.4. Adjusted coefficients of the TTS-model.

Activity [met]	$\Delta T_{sk < 0}$ [K]	$\Delta T_{sk \geq 0}$ [K]	$dT_{sk}/dt < 0$ [K/min]	$dT_{sk}/dt \geq 0$ [K/min]
Sedentary [0.8-1.0]	a0 = -10.0399521 a1 = 53.11225722 a2 = 26.63436155 a3 = 15.2633374	a0 = -1.246481875 a1 = 0.896983751 a2 = 0.40460998 a3 = 0.071579496	c1 = 35.83061211 c2 = 0.755610333 c3 = 0.15460694	c1 = 2.724189911 c2 = -0.039145888 c3 = 0.020192419
Physical [2.2-9.0]	a0 = -23.5072273 a1 = 2.228417288 a2 = -1.086042979 a3 = 0.714328235	a0 = -67.53168806 a1 = 48.83209002 a2 = -1.774948018 a3 = 0.392444918	c1 = 12.71522776 c2 = -1.113147345 c3 = 0.527215648	c1 = 10.96912946 c2 = -0.104337416 c3 = 0.005107006
Mean of both	a0 = -4.12635799 a1 = 7.929701101 a2 = 3.395151936 a3 = 4.78581774	a0 = -3.872242142 a1 = 2.846750559 a2 = 0.020641815 a3 = 0.891059178	c1 = 4.254275525 c2 = 0.001002048 c3 = 0.953917458	c1 = 2.736357959 c2 = -0.035450512 c3 = 0.026335738
	ΔT_{hyp} [K]		dT_{hyp}/dt [K/min]	
Sedentary [0.8-1.0]	b1 = -0.961064917 b2 = -0.070137053 b3 = 0.023639935		d1 = -0.195117863 d2 = -0.171638776 d3 = 0.002005248	
Physical [2.2-9.0]	b1 = 11.58911992 b2 = -0.095950405 b3 = 0.007515518		d1 = -0.900904574 d2 = 1.196506786 d3 = 0.066725999	
Mean of both	b1 = 3.408864704 b2 = 18.55280105 b3 = 5.502834303		d1 = -0.504119772 d2 = 1.075881675 d3 = 0.00000017153	

The mean deviation and correlation coefficient of the thermal sensation models, with regard of the experiments, are displayed in Table 2.4.5.

Table 2.4.5. Survey of the mean deviation and correlation coefficient (R) with regard of the experiments.

Activity	Temperature sensation model	Mean deviation [-]	R [-]	R ² [-]
Sedentary 0.8-1.0 met)	Fiala et al. (2003)	0,449	0,950	0,903
	TTS _{sedentary} (this study)	0,221	0,980	0,960
Physical (2.2-9.0 met)	Fiala et al. (2003)	1,048	0,808	0,653
	TTS _{physical} (this study)	0,266	0,985	0,970
0.8-9.0 met	Fiala et al. (2003)	0,712	0,889	0,790
	TTS _{mean of both} (this study)	0,381	0,957	0,915

By adjusting the coefficients in the model the calculation results, in particular the Figures 2.3.12 and 2.3.13, also change (see the figures 2.4.15 and 2.4.16).

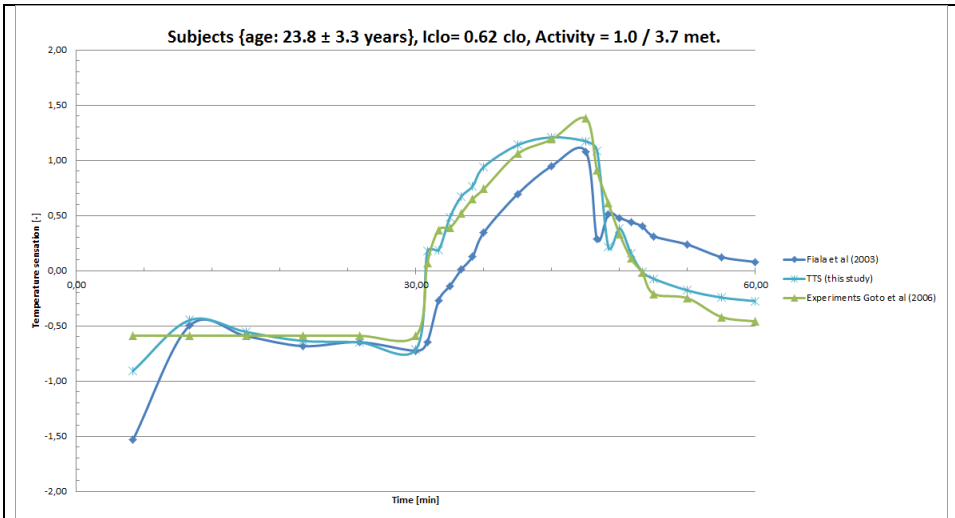

Figure 2.4.15. Average thermal sensation with metabolic step-changes (0-40-0% RW) at 21°C of stage 2 experiment (to compare with figure 2.4.13).

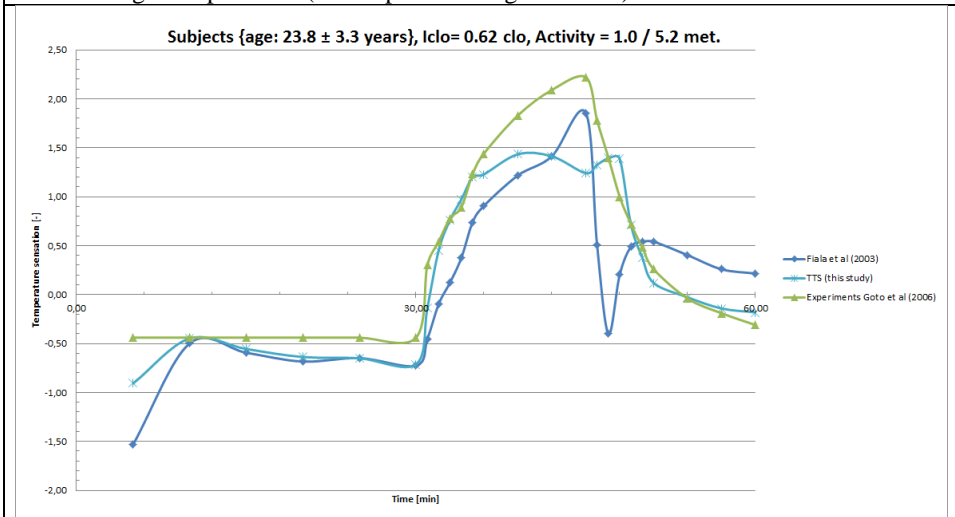

Figure 2.4.16. Average thermal sensation with metabolic step-changes (0-60-0% RW) at 21°C of stage 2 experiment (to compare with figure 2.4.14).

2.4.7 Conclusion

- This chapter shows that it is possible to derive a new reliable thermal sensation model, for a homogenous step-change transient thermal environment, by use of an additive of Lorentzian cumulative functions, on the basis of a thermophysiological model instead of measured data
- The difference with the equation derived by Takada et al. (120) is probably a result of not normalizing the skin temperature in their equation, with reference to for instance 34.4 °C, as advised and described in their publication. Regression analysis shows however better results when core temperature and the time differential of the core

temperature are taken along too besides the mean skin temperature and its time differential

- It is shown that in the considered situations the calculation results of the TTS-model are more accurate than with use of the DTS-model of Fiala et al. (19) on the basis of the Stolwijk model. This is not a result of the use of the Stolwijk model because the here displayed differences, between the experiments of Gagge et al. (115) and the DTS-method of Fiala (see figure 2.4.2), are also shown in the thesis of Fiala (112) in combination with the human thermal model of Fiala itself. The differences are a result of the thermal sensation model. A similar deviation is to recognize in the case of a high metabolism (viz. 8.7 met, see figure 2.4.6-2.4.8). A variation of the air temperature of 11.1 to 30.2 °C and a variation in the skin temperature of about 3K (viz. 34,1 – 37,2°C) shows a varying of the DTS from 2.14 to 2.99 (see figure 2.4.6-2.4.8). According to the experiments of Gagge et al. (121) however the thermal sensation should vary from -1 to 2.5, at the end of the experiments (see figures 2.4.6-2.4.8).
- It is shown that the calculation results of the TTS-model in combination with the Stolwijk model, at high metabolic rates (M; definitely if $M > 3.3$ met), are more accurate than the calculation results of the DTS-model in combination with the Fiala human model. (see figures 2.4.4 – 2.4.8)
- According to the literature the DTS model in combination with the Fiala human model has been tested until a metabolism (M) of 10 met (132), however it is shown that at high metabolic rates (definitely if $M > 3,3$ met), with or without use of the Fiala human model, the DTS model can be inaccurate (see figures 2.4.4 – 2.4.8). The reason for this could not be further pursued accurately since the Fiala human model is not an open source computer program.
- The fast rising of the thermal sensation at the end of the Neutral-Cool-Neutral-experiment of Gagge et al. (115) (see figure 2.4.2), for which Fiala (112) proposed a kind of numerical method to calculate this situation, is with the TTS-model analytically and straight forward calculable. In particular, this part of the calculation is an advantage with regard of the DTS-model of Fiala (19).
- The validity of the proposed model and (preliminary) coefficients is shown by the agreement between the thermal sensation votes from the experimental data, the validated Fiala DTS-model and the data calculated by the proposed TTS-model. It is revealed that the derived model successfully predicts thermal sensation at sedentary and physical activities in step-change transient thermally homogenous environments
- It is necessary to expand the number of experiments, on the basis of which the equation is derived, so that the scope of the model is extended, as Fiala did the same in the case of the DTS-model
- Thermal environments in free-running buildings, in which natural ventilation is dominant, can be regarded as dynamic thermal environments (124). These situations cannot be evaluated by the PMV/PPD-method, according to ISO-7730 (56), (124), as is nevertheless done in most comparative studies with regard of adaptation, for lack of better. With an accurate calculation of the thermal sensation in transient environments the field of study is one step closer to the solution of the problem to understand human response and thermal comfort in the ubiquitous dynamic thermal environment
- A suggestion is to standardize the classic and known experiments in the literature in future, on the basis of which reliable equations are to derive, so that for each dynamic human thermophysiological model equivalent to or more advanced than the Stolwijk model, the appropriate coefficients are to determine on the basis of the here proposed TTS-model.

3 Indoor Air Quality

- 3.1 Improvement and use of the carbon dioxide relationship for the evaluation of the perceived air quality depending on the air pollution caused by human bioeffluents

ABSTRACT. This chapter describes a method by which the perceived air pollution (in Olf), caused by human bioeffluents, and the percentage of dissatisfied as well as the performance improvement can be related to the difference in carbon dioxide concentrations of the air in the occupied zone and the supplied fresh air, without resorting to a panel trained in evaluating the air quality. This makes it possible, by means of relatively simple CO₂ and air flow quantity measurements, to make a quality assessment of the indoor air in meanings like percentage of dissatisfied, productivity change and olf in stead of just parts per million CO₂, as one is often used to in the professional practice.

Keywords

Air quality, carbon dioxide, olf, decipol, CR-1752, comfort, category, dissatisfied, performance, productivity.

3.1.1 Introduction

Some 27 years ago Fanger published a method to evaluate the perceived air quality (21). This method makes use of the human olfactory sensing device, i.e. the nose. This means that a situation is evaluated by a panel of people trained in evaluating the air quality by means of smell (133). Various research institutes (The Netherlands Organisation for Applied Scientific Research, the Fraunhofer Institute and the University of Rome) are occupied with the development of a so called “nose simulator” which incorporates quartz sensors. Each sensor responds to a particular smell or combination of smells, and the reaction is computer analysed by comparing the result with the established responses from a trained panel of people.

Despite these efforts, no portable, handy and dependable device has been developed yet with which one person is able to execute measurements of the air quality in a fast, simple and inexpensive manner.

Practically Fanger found that during the course of carrying out the air quality investigations, it was necessary for the panel to visit the buildings several times (on average two or three times). In the first instance to establish the pollution load of the building when occupied and ventilated; a second time to determine the pollution load of the building unoccupied however actively ventilated and a third time when the building was both unoccupied and unventilated to investigate the pollution loading as a direct result of the building materials. Subsequently, it was found possible to reduce the actual number of panel visits by correlating carbon dioxide measurements to the perceived responses of the trained persons (134).

These measurements are particularly interesting where human bioeffluents are the main pollution source i.e. congress assembly rooms, sport halls and fitness rooms, however equally applicable where other pollution sources affect the overall air quality (134).

Research has shown that, very quickly, the benefits resulting from even a small productivity increase far exceeds the investment necessary to improve the working environment (96).

3.1.2 The carbon dioxide production and human bioeffluents

Human bioeffluents are not easy to measure. Exhaled air consists predominantly of carbon dioxide, and it has been a long held opinion that man was the largest air source of pollution, therefore carbon dioxide concentration could be considered to be a good indicator of the total perceived air quality in a room.

Fanger and others proved that carbon dioxide concentrations and bioeffluents indeed correlated well with each other (135), (136) but that the percentage of carbon dioxide surely may not be seen as a totally attributable indicator of the total perceived air pollution in a room (137). This could only be the case in situations in which bioeffluents could be identified as the main air pollution source. Carbon dioxide concentration measurement is relatively simple to carry out, therefore it is a useful aid in determining air quality.

3.1.3 Air quality and CO₂ concentration

Air quality may be expressed as a percentage in terms of the number of persons evaluating the air as being unacceptable upon first entering a space. When CO₂ concentration is used the unitary indicator of air quality it must be defined i.e. ppm, vol %, mg/m³, or m³/m³. The important factor here is however the relationship between the CO₂ concentration and the percentage of dissatisfied due to bioeffluents in a space. To deduce this relationship the defined air pollution rates in “olf” at various metabolic rates, formulated by Fanger (Table 3.1.1) and the relationship between CO₂ production and metabolic rate are used. Thereafter, by means of

multiple linear regression analysis, a relationship is deduced between the air volume per “olf” and the CO₂ concentration differences between the outside and inside air.

Table 3.1.1. Pollution rate per person (21).

<i>Activity (met*)</i>	<i>Olf</i>
Seated/sedentary, 1-1,2 met	1
Physical activity – low, 3 met	4
Physical activity – average 6 met	10
Physical activity - high 10 met	20

By re-applying the defined CO₂ concentration differential (ΔCO_2) in the deduced exponential function for the percentage of dissatisfied, as established by Fanger (viz. $\text{PD}_{\text{olf}} = 395 \cdot \exp(-1.83 \cdot q^{0.25})$), the following equation will result :

$$\text{PD}_{\text{CO}_2} = 395 \cdot \exp(-35.69857 \cdot (C_i - C_0)^{-0.3388155} \cdot V^{-0.08881763}), \{R^2 = 0.99998; \sigma = 0.0024\}$$

A similar formula is published in the Dutch-European guideline NPR-CR-1752 (22) as follows:

$$\text{PD}_{\text{NPR-CR-1752}} = 395 \cdot \exp(-15.15 \cdot (C_i - C_0)^{-0.25});$$

In which:

- C_i = CO₂ concentration in the occupied space in ppm;
- C_0 = CO₂ concentration in the supply air in ppm;
- V = supplied fresh air quantity in m³/h per person.

For comparison, the calculation results of the three above-mentioned exponential functions are shown for a number of situations in Table 3.1.2, wherein ideal mixing is assumed. It is noted that the displayed large CO₂-concentration differences here with a properly sized ventilation system will not occur.

Table 3.1.2. Percentage of dissatisfied due to the air quality.

Fresh air [m ³ /(h.pp)]	Parameter	Unit	Metabolism [Met]			
			1.1	3	6	10
20	ΔCO_2	[ppm]	832	-	-	-
	PD _{CO₂}	[%]	23.9	-	-	-
	PD _{olf}	[%]	23.8	-	-	-
	PD _{cr1752}	[%]	23.5	-	-	-
30	ΔCO_2	[ppm]	555	1513	-	-
	PD _{CO₂}	[%]	17.7	43.3	-	-
	PD _{olf}	[%]	17.6	43.8	-	-
	PD _{cr1752}	[%]	17.4	34.8	-	-
40	ΔCO_2	[ppm]	416	1135	-	-
	PD _{CO₂}	[%]	14.1	36.8	-	-
	PD _{olf}	[%]	14.0	37.2	-	-
	PD _{cr1752}	[%]	13.8	29.0	-	-
50	ΔCO_2	[ppm]	333	908	-	-
	PD _{CO₂}	[%]	11.6	32.1	-	-
	PD _{olf}	[%]	11.5	32.5	-	-
	PD _{cr1752}	[%]	11.4	25.0	-	-
60	ΔCO_2	[ppm]	277	756	1513	-
	PD _{CO₂}	[%]	9.9	28.6	49.5	-
	PD _{olf}	[%]	9.8	28.9	49.4	-
	PD _{cr1752}	[%]	9.6	22.0	34.8	-
70	ΔCO_2	[ppm]	238	648	1297	-
	PD _{CO₂}	[%]	8.5	25.8	45.6	-
	PD _{olf}	[%]	8.5	26.1	45.5	-
	PD _{cr1752}	[%]	8.3	19.6	31.6	-
80	ΔCO_2	[ppm]	208	567	1135	-
	PD _{CO₂}	[%]	7.5	23.5	42.4	-
	PD _{olf}	[%]	7.4	23.8	42.3	-
	PD _{cr1752}	[%]	7.3	17.7	29.0	-
100	ΔCO_2	[ppm]	166	454	908	1513
	PD _{CO₂}	[%]	6.0	20.0	37.3	54.3
	PD _{olf}	[%]	5.9	20.3	37.2	54.2
	PD _{cr1752}	[%]	5.8	14.8	25.0	34.8

3.1.4 (Dutch-)European guideline (NPR-)CR-1752

The (Dutch-)European Practical guideline (NPR-)CR-1752 “Ventilation of Buildings – Design Criteria for the internal conditions”, dated January 1999 (22), defines three categories of air quality, shown in Table 3.1.3.

Table 3.1.3. Three Categories of Air Quality, in accordance with NPR-CR-1752 (22).

Category	Perceived Air Quality		CO ₂ -concentration difference relative to outside ¹⁾ [ppm]
	Dissatisfied [%]	Decipol [dp]	
A	<15	<1.0	<460
B	<20	<1.4	< 60
C	<30	<2.5	<1190

¹⁾ Occupants with a sedentary activity are the only air pollution source. The Ventilation Effectiveness = 1.

3.1.5 Air quality and productivity

Investigations by Wargoeki et al. (40) have demonstrated that air quality can have significant positive and/or negative effects upon the productivity of office workers. An office with climatic control system was used to create various air quality situations. The same group of people worked continuously in a simulated office environment for 4½ hours. The performances, dependent upon the actual office activity, when in an environment using air of the highest quality, were impressively higher than other circumstances. Furthermore, the amount of Sick Building Syndrome symptoms was much less than occurred when the ventilation air was of an inferior quality.

By combining these research results together with calculation method, proscribed earlier, it is possible to relate the influence of the air quality and the comfort of office workers to the CO₂ concentration difference between the space and the outside air, as shown in Figure 3.1.1.

The presumption is that the office workers are the only source of air pollution and that the air is properly mixed. The values of the (blue) curve with no plot symbol are to be read off from the Y-axis on the left and the values of the (red) curves with plot symbols are to be read off from the Y-axis on the right. The category definitions refer to the percentage of dissatisfied.

The impact of air quality on employee performance and comfort in office environments

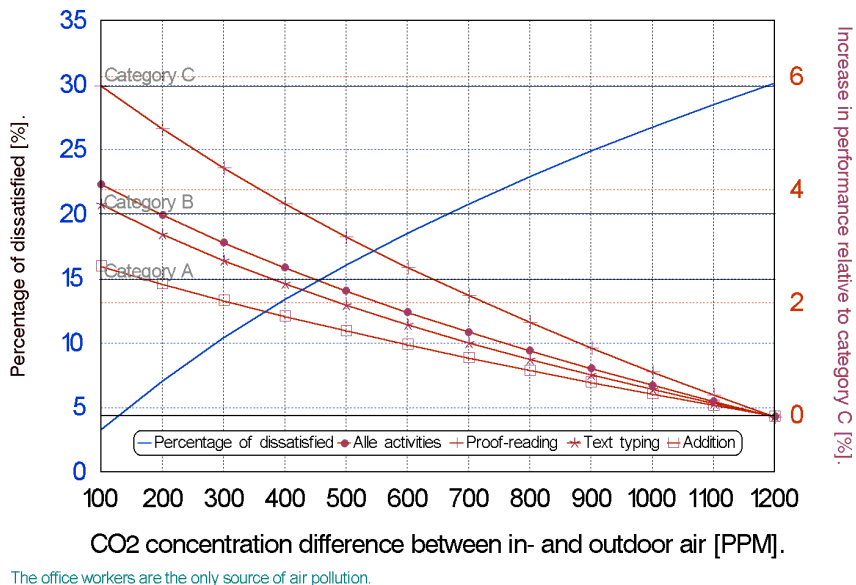

Figure 3.1.1. The impact of air quality on employee performance and comfort in office environments.

It should be clear that, in the event that the occupying office workers are not the sole source of the air pollution then if the percentage of dissatisfaction remains the same the CO₂ concentration difference between the in- and outdoor air should be lower than purely if the source was the office workers.

In figure 3.1.2, an example of a situation is illustrated in which the pollution rate, as a result of the furnishing and installations, is 0.05 olf/m² (in other words a “low olf” building) and that a very good outside air quality is available at 0.1 decipol.

The impact of air quality on employee performance and comfort in low-olf office environments

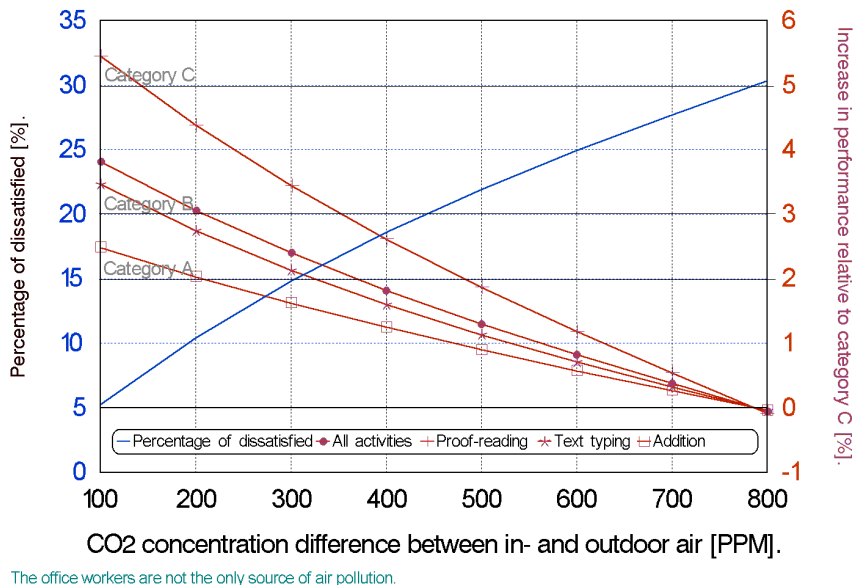

Figure 3.1.2. The impact of air quality on employee performance and comfort, in low-olf office environments.

3.1.6 Conclusion

This chapter introduces a formula which shows that the percentage of dissatisfied, due to the perceived air quality in a room, is a function of the CO₂ concentration difference between the air in the occupied space, and the quality of fresh air, as well as the amount of fresh air, supplied to each person, when the air is polluted by people. This makes it possible, by means of relatively simple CO₂ and air flow quantity measurements, to make a quality assessment of the pollution in the air (in “olf”) as well as a judgement in regard to performance differences (relative to category C [minimum] conforming with NPR-CR-1752), without using a group/team or panel of trained persons (134).

The formula published in the Practical Recommendations for percentage dissatisfaction (PD_{NPR-CR-1752}) when compared with the other two exponential formulas (PD_{CO₂} en PD_{olf}) shows a marked deviation when a higher metabolic rate than 1.1 met is used, therefore is probably only relevant to low metabolic activities.

The calculation results in Table 3.1.2 shows also that even if there is an increase in the air quantity (with a constant CO₂ concentration difference) the percentage of dissatisfied (PD_{CO₂} and PD_{olf}) increases and is consequently larger than one would expect from a purely CO₂ concentration difference. This however confirms the conclusions drawn from the research by Rasmussen (135). During the previously mentioned research, with the same CO₂ concentration and body odour intensity – according to a slightly modified Yaglou scale – the actual body odour produced by persons, performing higher levels of physical activity, were found to be less acceptable than the body odour produced under less strenuous physical activity.

The methodology described here lends itself to the study of the air quality, whereby a fast and simple impression of the role the type of air pollution (viz. building and/or occupants) plays in the result.

Furthermore, and in the absence of reliable measuring instrumentation, the use of this method can lead to the possibility of simplified practical air quality investigations (134). Combining these results with the research results of Wargocki et al. (40), it is also possible to quantify the effects upon productivity, due to air quality, under comparable office accommodation situations. The research results of Wargocki et al. show that the influence of air quality is greatest for people carrying out office tasks like proof reading than for persons involved in tasks like addition and text typing (40).

- 3.2 A new methodology for the evaluation of the perceived air quality depending on the temperature and the humidity of the air and the air pollution caused by human bioeffluents

ABSTRACT. Different researchers found an influence of the air temperature and the air humidity on the perceived air quality which within the olf-decipol-method of Fanger is not taken into account. The aim of this research is to examine to what extent, with the aid of the freshness of the air and the olf-decipol-method of Fanger, it is possible to distract a methodology for the evaluation of the perceived air quality depending on the temperature and the humidity of the air and the air pollution caused by human bioeffluents.

Keywords

Perceived air quality, human bioeffluents, olf, decipol, temperature, humidity, freshness, percentage of dissatisfied, performance, fatigue.

3.2.1 Introduction

About twenty seven years ago Fanger published for the first time a method to assess the perceived indoor air quality (21). This method uses the air quality assessed through the human nose by a group of people (panel) that is trained in observing the air-quality (133). Fanger introduced two new concepts, namely the olf and the observed decipol respectively for air pollution and air quality.

Later on other researchers noted the influence of air enthalpy on the perceived air quality that within the method of Fanger is not taken into account (138), (139). Today, there is no generally applicable mathematical model with which the percentage of dissatisfied due to the perceived air quality as a function of the air temperature and the air humidity can be expressed and that takes into account all forms of air pollution (e.g. caused by humans, the interior, the ventilation system and the outdoor air) in practice, without making use of a group of trained people on observing the air quality. For the time being there is no handy and reliable electronically device in trade that, quickly, easily, used by one person and without much costs, measures the perceived indoor air quality, in accordance with the olf-decipol-method of Fanger. This makes the applicability of the olf-decipol-method in practice difficult. Besides that there is another problem with regard of the olf-decipol method which have to be solved. In the approach of the olf-decipol method the perceived air quality is modelled using one exposure-response relationship between ventilation rate and the perceived quality of air polluted by human bioeffluents, independently of the type of pollution source. But as shown in a research of Knudsen et al. (140) the relationship between the ventilation rate and the perceived quality of air polluted by human bioeffluents is different from the corresponding relationships for building materials. The slope of 0.25 ± 0.08 is lower for the majority of the building materials. This implies that the effect on the perceived air quality of a change in ventilation rate will be underestimated when using the relationship for human bioeffluents rather than the actual relationship (140). However this study is limited to the air pollution caused by humans, on which the olf-decipol method has been developed.

As long as this situation applies it is obvious to consider to which extent, with relatively simple to determine indicators such as the CO-and the CO₂-percentage, a right connection can be found with the latest insights (141), (142). Following the aforesaid problems, Clements-Croome proposed the freshness of the air as a scale to determine the percentage of dissatisfied due to the perceived air quality as a function of the freshness instead of the decipol (143). The aim of this research is to examine to what extent using the freshness of the air and the olf-decipol-method of Fanger an in practice usable methodology for the evaluation of the perceived air quality is to derive, depending on the temperature and the humidity of the air and the air pollution caused by human bioeffluents; also in view of the current laws and regulations. After all the Dutch regulations for indoor air quality considers only the air pollution that people cause, since this source is unavoidable. Other air pollution sources affecting indoor air quality (such as interior design, installations, the building and the outdoor air) in the Dutch laws and regulations are disregarded and are the responsibility of the market parties (144).

The research of Berglund & Cain (138) is the first, well documented, research in which the influence of the air temperature and the air humidity on the perceived air quality is demonstrated and where the subjects themselves are the only source of contamination. In the later research of Fang et al. (139) certain building materials are the sources of pollution. Having regard to the objective it seems therefore to make sense at first to start off on the basis of the research of Berglund & Cain (138).

3.2.2 Research Berglund & Cain

The research was conducted in a test chamber using a group of twenty persons, consisting of 10 men and 10 women aged from 18 to 62 years, which were divided in groups of 5 people. The temperature and relative humidity in the test room were adjustable. The ventilation amounted $267 \text{ m}^3/\text{h} \pm 31 \text{ m}^3/\text{h}$. Subjects responses were measured at three metabolisms, namely: 0.94 met (sitting), 1.95 met (five-minute walk, stand for five minutes) and 2.82 met (continuous walking). The average clothing resistance was $0.56 \pm 0.04 \text{ clo}$. All test subjects took part in twenty seven different tests of one hour, defined by the combination of three air temperatures, three relative humidities and three metabolisms.

Of five people the body temperature, the skin temperature, the heart rate and the skin humidity were continuously measured, while two times each test the oxygen consumption was measured. From this the actual metabolism could accurately be calculated. The subjects gave immediately after entering the test room and every 15 minutes after that their judgement on the indoor air quality on the basis of a questionnaire. Three questions were directly related to the air quality (freshness, stuffiness, acceptability) and four indirectly (skin moisture, humidity, air motion and thermal sensation).

The research showed, in addition to the influence of the enthalpy of the air on the perceived air quality, also that the air temperature had a somewhat more potent influence on perceived air quality than did humidity. The chamber contained essentially no active odor sources, except for the occupants themselves, and had the relatively high ventilation rate of at least 15 l/s per person of clean air. The perceived air quality and the freshness of the air turned out to be almost independent of the time within the experiment. This was not due to adaptation since the maximum exposure time was one hour and research shows that adaptation occurs only after approximately one hour exposure (145). A person's olfactory system adapts to odor in a short time so odor intensity decreases with exposure, but in this case the staleness perception did not diminish with time, implying that the chamber air was odorless.

It was concluded that the temperature and the humidity of the air in certain cases might be of larger affect on the perceived air quality than the air-pollution itself. Which supports the proposal by Clements-Croome to use the freshness of the air as a scale to evaluate the perceived air quality.

3.2.3 Freshness of air

One of the aims of this research is the mathematical relationship between the freshness of the air, the air pollution caused by human bioeffluents, the air temperature and the air humidity. For that, use is made of the research results of Berglund & Cain (138).

By means of multiple regression analysis the relationship is established with the freshness of the air as a function of the ratio of the rate of air pollution generation to the rate of fresh air inlet flow as well as the dry and the latent heat transfer on the surface of the nasal mucosa. The heat transfer in the nose is taken because the nose is the primary sensory surface where the freshness of the air is observed. The heat balance on the nasal mucosa assume the minimum surface temperature of $30.2 \text{ }^\circ\text{C}$ (146) and a relative humidity of 100% (20). Further is used the air pollution load in olf at different metabolisms, as determined by Fanger (21), for which, in this study, the following relationship is derived:

$$G = 0.985.M^{1.299} \{R^2 = 0.9999; \sigma = 2.62.10^{-2}\} \quad (1)$$

Herein is:

- G = air pollution load per person[olf]
- M = metabolism [met].

In this study analysis by multiple regression obtained an equation for the freshness of the air, on the basis of an air pollution load balance (shaded in blue) and a heat and moisture balance of the nasal mucosa (shaded red), reads:

$$F = a + b.(30.2 - t_a) + c.(42.94 - 0.01.p_a) + d.10.G/(V.\epsilon), \{R^2 = 0.918; \sigma = 0.239\} (2)$$

Herein is:

- F = freshness of the air, according to a seven point scale [0-6]
- t_a = air temperature [°C]
- p_a = vapor pressure of the air [Pa]
- G = air pollution load [olf]
- V = fresh air quantity [l/s]
- ϵ = ventilation-effectivity, according to NPR-CR-1752 (22)
- a = 5.627
- b = -0.265; regression coefficient convective heat transfer
- c = -0.044; regression coefficient latent heat transfer
- d = 0.232; regression coefficient air pollution load.

In Figure 3.2.1 the observed values (138) and the predicted values (formula 2) for the freshness of the air are compared to each other.

The developed model is valid for:

- $21^\circ\text{C} \leq t_a \leq 27^\circ\text{C}$
- $717 \text{ Pa} \leq p_a \leq 2339 \text{ Pa}$
- $3.9 \text{ l/(s.olf)} \leq V/G \leq 16.3 \text{ l/(s.olf)}$
- $0.94 \text{ met} \leq \text{metabolism} \leq 2.82 \text{ met}$
- $18 \leq \text{age} \leq 62 \text{ years}$.

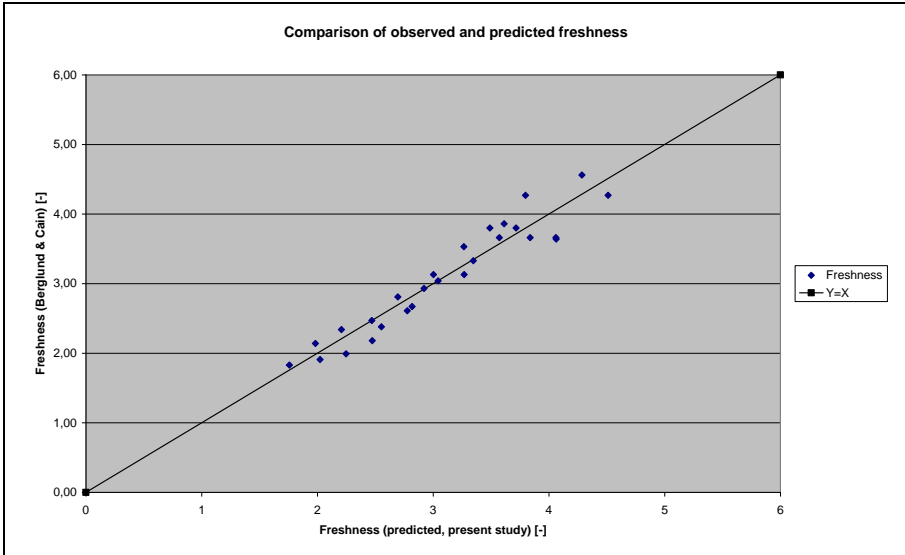

Figure 3.2.1. Comparison of observed and predicted freshness.

Figure 3.2.1 shows that the predicted freshness of the air well matches with the observed freshness of the air.

3.2.4 The percentage of dissatisfied

In the research of Berglund & Cain the subjects were not explicitly asked about the dissatisfaction but if the observed air quality was sufficiently unacceptable for them to make a change as in leave the place, open a window, turn on a fan, etc. For this research it is assumed that the number of dissatisfied is determined by the subjects who find the observed air quality sufficiently unacceptable to make a change. With this premise, based on the research results of Berglund & Cain, the following function for the percentage of dissatisfied was derived:

$$PD = 100 / (1 + \exp^{(4.901 - 1.215.F)}) \{R^2 = 0.78; \sigma = 9.09\} \quad (3)$$

Herein is:

- PD = percentage of dissatisfied due to the air quality [%]
- F = freshness of the air [0-6].

According to the research of Clements-Croome (143) the percentage of dissatisfied, as a function of the freshness of the air in existing offices, is to be calculated with the function:

$$PD = 100 \cdot \exp^{(-0.652 \cdot (F + 6))} \quad (4a)$$

Herein is:

- PD = percentage of dissatisfied due to the air quality [%]
- F = freshness of the air [0 - 6].

According to the research of Fanger et al. (147) (subjects: 27 men and 27 women , age range 18 – 30 years) and on the basis of multiple regression in this study an equation is obtained for the percentage of dissatisfied due to perceived air quality as a function of freshness:

$$PD = 100 / (1 + \exp^{(6.65 - 1.588 * F)}), \{R^2 = 0.83; \sigma = 6.86\} \quad (4b)$$

Herein is:

- PD = percentage of dissatisfied due to the air quality [%]
- F = freshness of the air [0 - 6].

In Figure 3.2.2 are displayed graphically the percentage of dissatisfied from the research of Berglund & Cain (138), the predicted percentage of dissatisfied calculated using the formula (3) derived in this study (red curve) as well as the formula (4a) from Clements-Croome (dark blue curve). For completeness also the research results of Toftum et al. (20) (students; 19 men and 19 women) and Fanger et al. (147), formula 4b, are included.

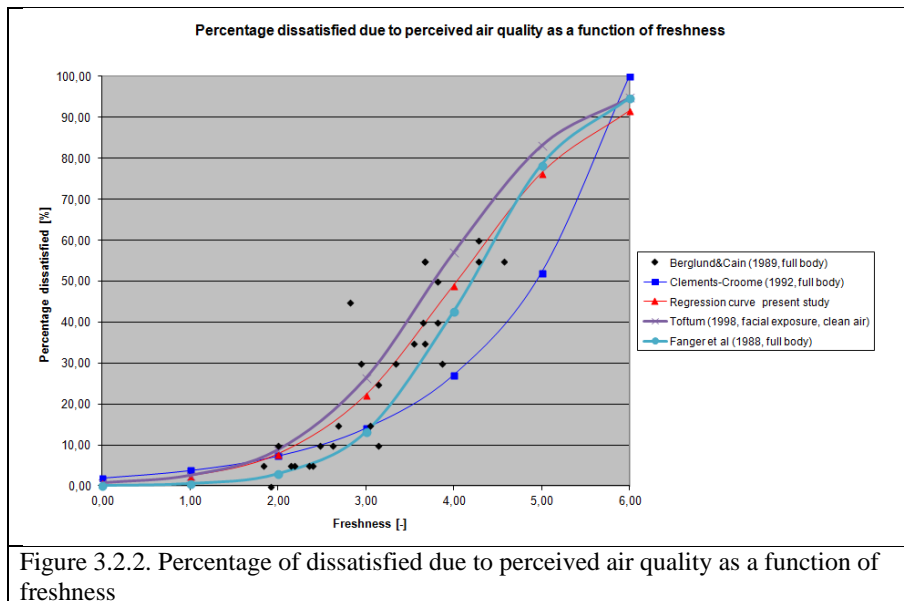

Figure 3.2.2. Percentage of dissatisfied due to perceived air quality as a function of freshness

3.2.5 The percentage of dissatisfied due to the freshness of clean air

An attempt has been made to compare the model developed here with the results of other surveys, in which the influence of the enthalpy on the acceptance and the dissatisfaction of clean air is determined (139), Toftum et al. (20) (see Figures 3.2.3-3.2.5).

In some cases, the ambient air from the climatic chamber was transported to the face (facial exposure) of the subjects, who stood outside the climatic chamber instead of the situation where the whole body of the subjects was exposed to the ambient air in the climatic chamber (full body exposure), such as in the investigation of Berglund & Cain (138). The percentage of dissatisfied as a result of the perceived air quality in the investigation of Fang et al. (139) is, for the situation of facial and full body exposure, determined with both the Wargocki et al. (148) and the Gunnarsen & Fanger (149) derived formulas, namely:

Facial exposure (148)

$$PD = 100 / (1 + \exp^{(4.28 * Acc + 0.42)}) \quad (5)$$

Herein is:

- PD = percentage of dissatisfied due to the air quality [%]
- Acc = acceptability of the air [-].

Full body exposure (149)

$$PD = 100 / (1 + \text{Exp}^{(5.28 \cdot \text{Acc} + 0.18)}) \quad (6)$$

Herein is:

- PD = percentage of dissatisfied due to the air quality [%]
- Acc = acceptability of the air [-].

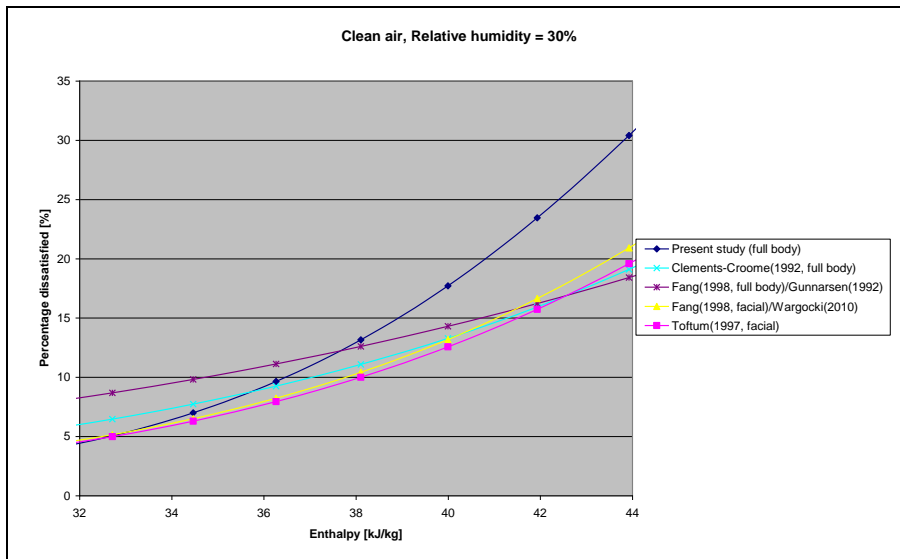

Figure 3.2.3. The influence of the enthalpy on the dissatisfaction of clean air

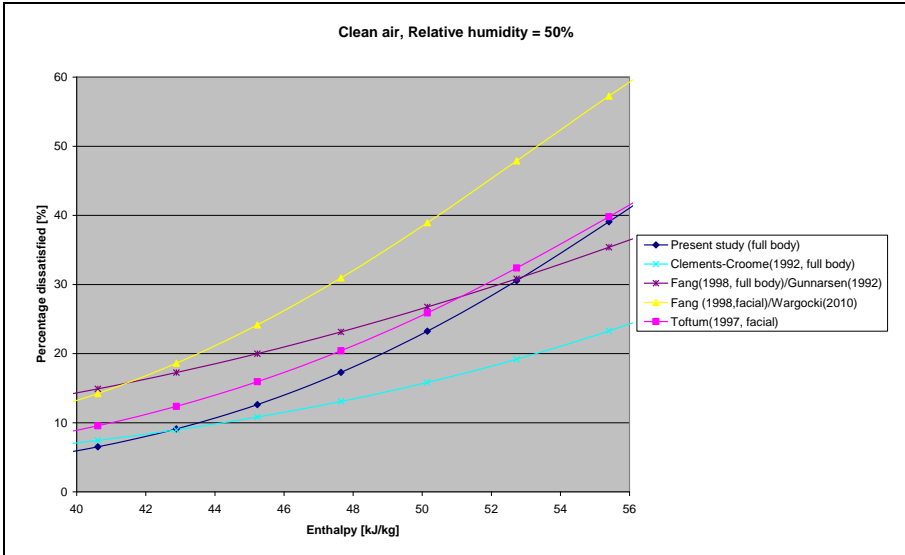

Figure 3.2.4. The influence of the enthalpy on the dissatisfaction of clean air

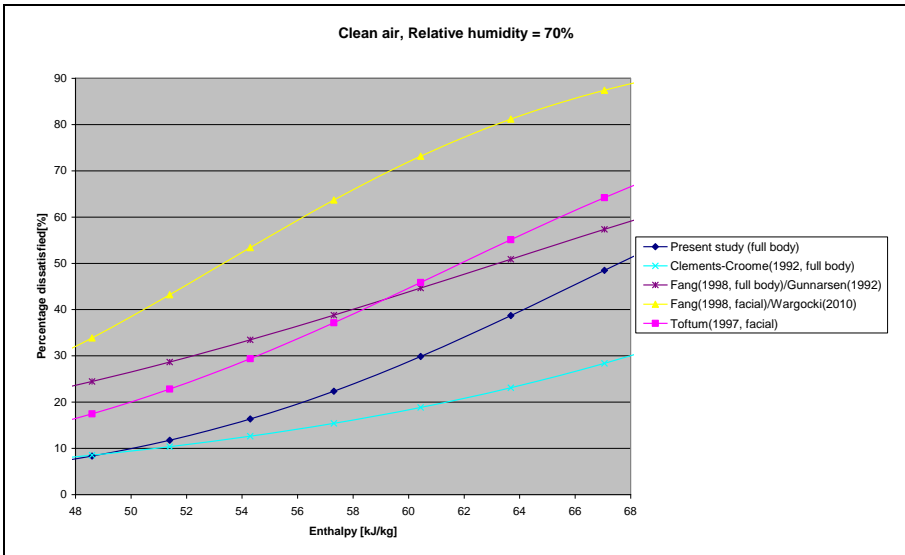

Figure 3.2.5. The influence of the enthalpy on the dissatisfaction of clean air

Figures 3.2.3-3.2.5 show that the model developed here (full body exposure):

- at a low relative air humidity (RH = 30%) and a relatively high air temperature (> ca. 25 °C) differs from other research results
- at a normal to a high relative humidity is approximately in the middle of other research results
- at high relative humidity the predicted percentage of dissatisfied is lower for full body exposure than the facial exposure research results of Fang and Toftum where the ambient air from the climatic chamber is transported to the face (facial exposure) of the subjects. Which corresponds to the findings of Fang et. al (1998).

3.2.6 Influence of air temperature, relative air humidity and air quality

The freshness of the air is in the research of Berglund & Cain (138) was scored on a seven point scale from 0 to 6. Clements-Croome (143) also used a seven point scale for the freshness of the air, however from -3 to 3, with a verbal qualification of the freshness of the air. This is shown in Table 3.2.1.

Table 3.2.1. Freshness of the air.

Study	Scale and rating (qualification)								
	Stale								Fresh
Berglund & Cain (1989)	Score	6	5	4	3	2	1	0	
		Very	Fairly	Slightly	Neither	Slightly	Fairly	Very	
Clements-Croome (2008)	Score	-3	-2	-1	0	1	2	3	

To get an impression of the influence of air temperature and relative humidity on perceived air freshness for air quality categories A, B and C, according to (NPR) CR-1752 (22), the model predictions for freshness of air are graphically displayed in the figures 3.2.6 through 3.2.8. For illustration the verbal qualification, according to the research by Clements-Croome (143) is also shown. The comfort area, depending on the air quality category, is shaded green in the charts.

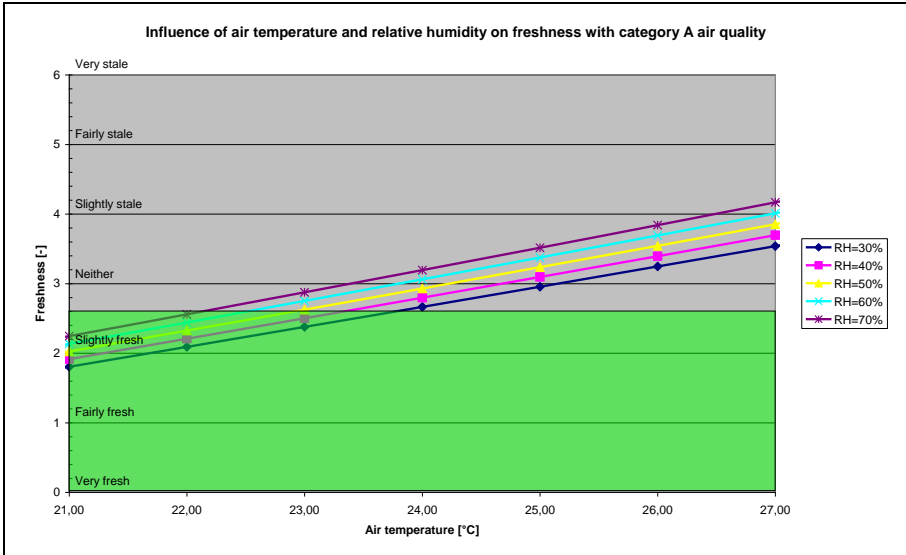

Figure 3.2.6. Category A air quality {PD<15%, V/G=10 l/(s.olf)}.

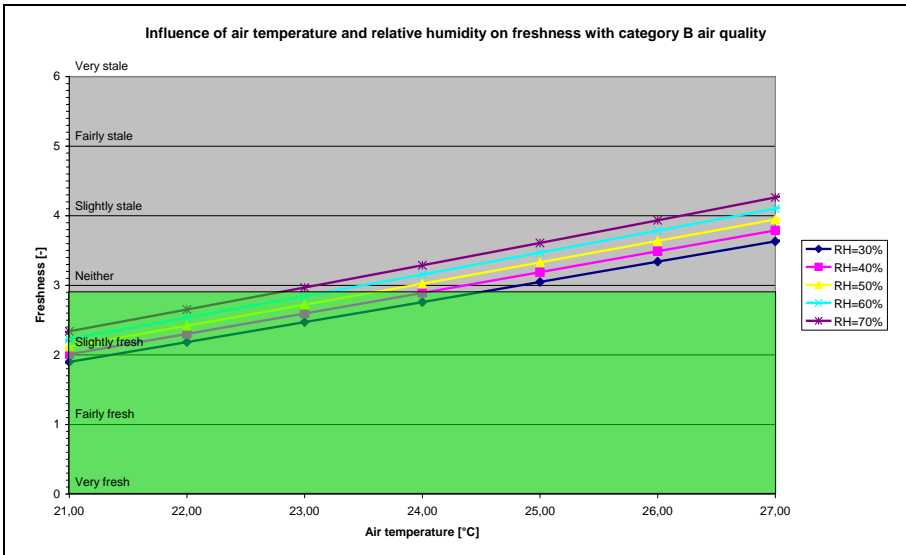

Figure 3.2.7. Category B air quality {PD<20%, V/G=7 l/(s.olf)}.

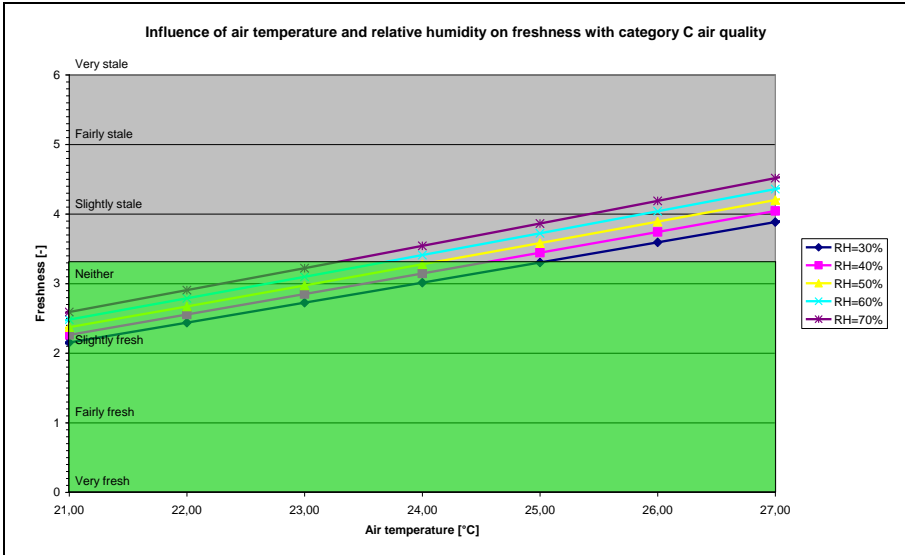

Figure 3.2.8. Category C air quality {PD<30%, V/G=4 l/(s.olf)}.

3.2.7 Influence of freshness on the percentage of dissatisfied

Figures 3.2.9 through 3.2.11 graphically show to what extent the freshness of the air affects the air quality as a result of the percentage of dissatisfied, according to (NPR-)CR-1752 (22). The comfort area, depending on the air quality category, is shaded green in the charts.

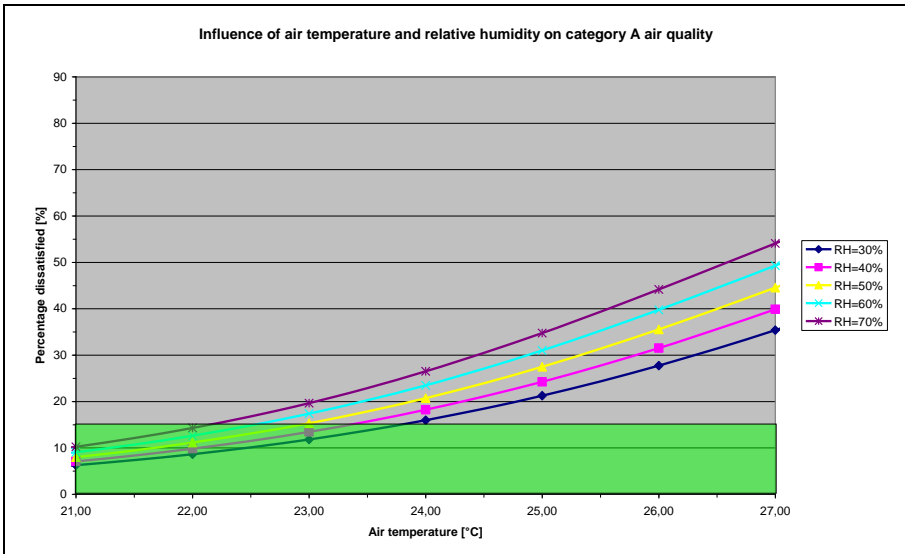

Figure 3.2.9. Category A air quality {PD<15%, V/G=10 l/(s.olf)}.

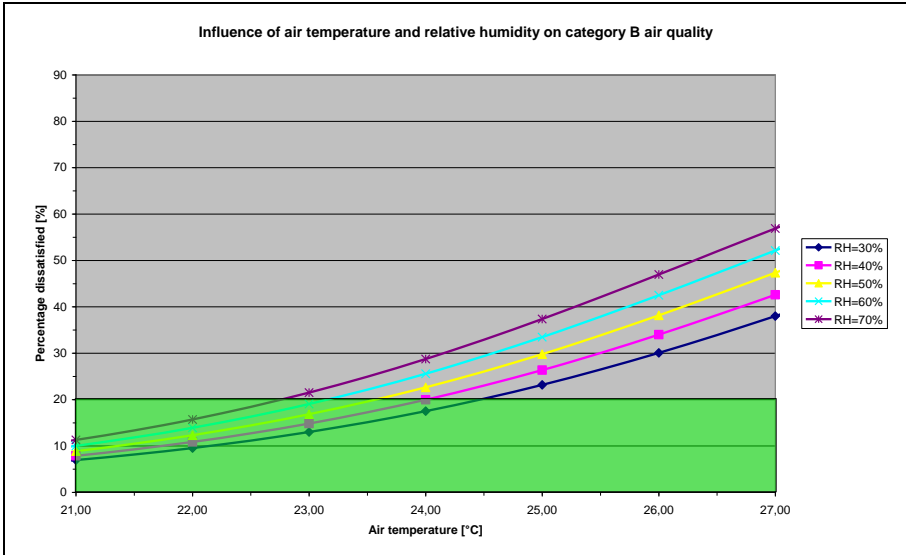

Figure 3.2.10. Category B air quality {PD<20%, V/G=7 l/(s.olf)}.

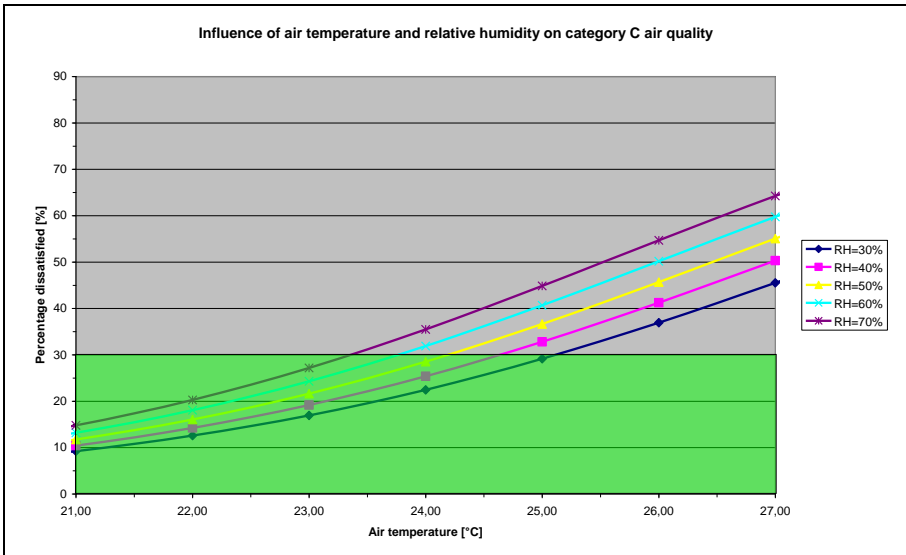

Figure 3.2.11. Category C air quality {PD<30%, V/G=4 l/(s.olf)}.

3.2.8 The carbon dioxide percentage

According to Roelofsen (142), the following relationship exists between the carbon dioxide levels above outdoor air, the inlet air quantity per person and the percentage of dissatisfied. The formula fits in well with the olf-decipol-method of Fanger, in situations where man is the main air pollution source.

$$PD = 395 * \text{Exp}(-35.699 \cdot \Delta\text{CO}_2^{-0.339} \cdot V^{-0.089}) \quad (7)$$

Herein is:

- PD = the percentage of dissatisfied [%]
- V = the inlet air quantity per person [m³/(h.pp)]
- ΔCO₂ = the carbon dioxide level above outdoor air [ppm].

In (NPR-)CR-1752 (22) a similar link between the carbon dioxide levels above outdoor air and the percentage of dissatisfied is shown, however if the metabolism is limited to 1.1 met.

$$PD = 395 * \text{Exp}(-15.15 * \Delta CO_2^{-0.25}) \quad (8)$$

Herein is:

- PD = the percentage of dissatisfied [%]
- ΔCO₂ = the carbon dioxide level above outdoor air [ppm].

In situations where the carbon dioxide level above outdoor air (in the living area) is the indicator of the air quality instead of the air pollution load in olf, formula 2 is to rewrite, namely:

$$F = a + b.(30.2 - ta) + c.(42.94 - 0.01.pa) + d.\Delta CO_2, \{R^2 = 0.919; \sigma = 0.238\} \quad (9)$$

Herein is:

- F = freshness of the air, according to a seven point scale [0-6]
- ta = air temperature [°C]
- pa = vapor pressure of the air [Pa]
- ΔCO₂ = the carbon dioxide level above outdoor [ppm]
- a = 5.536
- b = -0.265; regression coefficient convective heat transfer
- c = -0.044; regression coefficient latent heat transfer
- d = 0.085.10⁻²; regression coefficient air pollution load.

In Figure 3.2.12, the percentage of dissatisfied is displayed as a function of the carbon dioxide levels above outdoor, on the basis of formula 7 and 9. It is based on an inlet air quantity per person of 53.4 m³/(h. pp) and a relative air humidity of 50%.

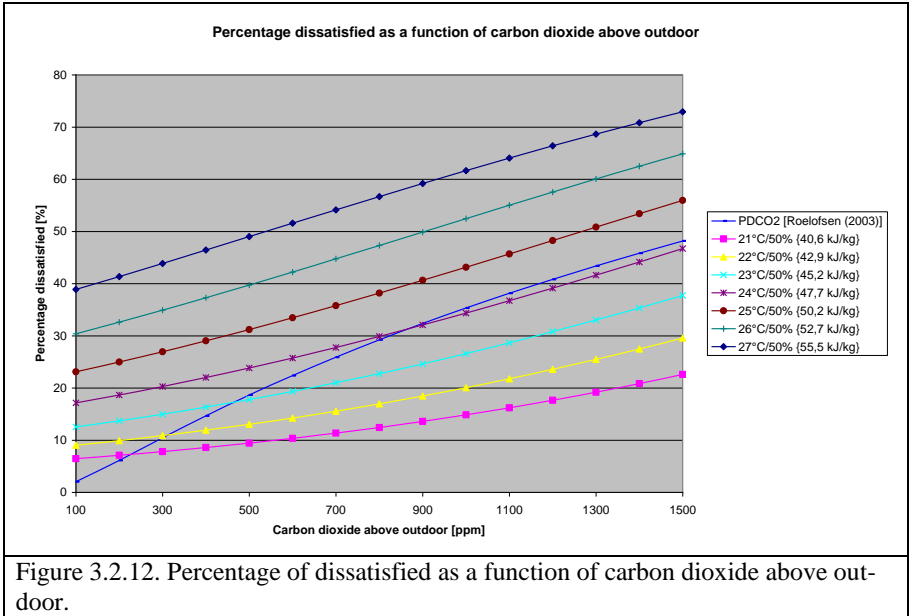

Figure 3.2.12. Percentage of dissatisfied as a function of carbon dioxide above outdoor.

Figure 3.2.12 shows the influence of the air temperature in combination with the carbon dioxide levels above the outdoor air on the percentage of dissatisfied as a result of the perceived air quality. Figure 3.2.12 shows that, for 50% relative humidity, the air temperature above a certain limit, in this case ca. 24 °C (enthalpy 47.7 kJ/kg), has extremely negative effects on the percentage of dissatisfied as a result of the CO₂-level. On the other hand, with a lower air temperature it shows a significant positive effect. Once again, a reason to design a cool climate, when it concerns the convective heat balance in a room.

3.2.9 Influence of freshness on the learning performance

Jacobs et al. (53) have developed, on the basis of a number of investigations into the impact of air quality on the learning performance of pupils, a mathematical relationship between the relative learning performance and the carbon dioxide level, namely:

$$RP = 322 * CO_2^{-0.159} \quad (10)$$

Herein is:

- RP = relative performance [%]
- CO₂ = The carbon dioxide concentration [ppm].

To rewrite formula 8 and use it in formula 10 one obtains a relationship between the relative performance and the percentage of dissatisfied as a result of the perceived air quality. Ignored is that formula 8 is developed on the basis of the CO₂ production of a standard adult person. Strictly speaking formula 8 needs to be adjusted in this respect.

$$RP = 322 * (((LN(PD/395))/-15.15)^{-4} + CO_{2 \text{ outdoor air}})^{-0.159} \quad (11)$$

Figures 3.2.13-3.2.15 show to what extent freshness affects the learning performance. The comfort zone and their relative performance, depending on the category air quality, according

to (NPR-)CR-1752, is shaded green in the charts. The carbon dioxide content of the outdoor air is presumed to be 390 ppm.

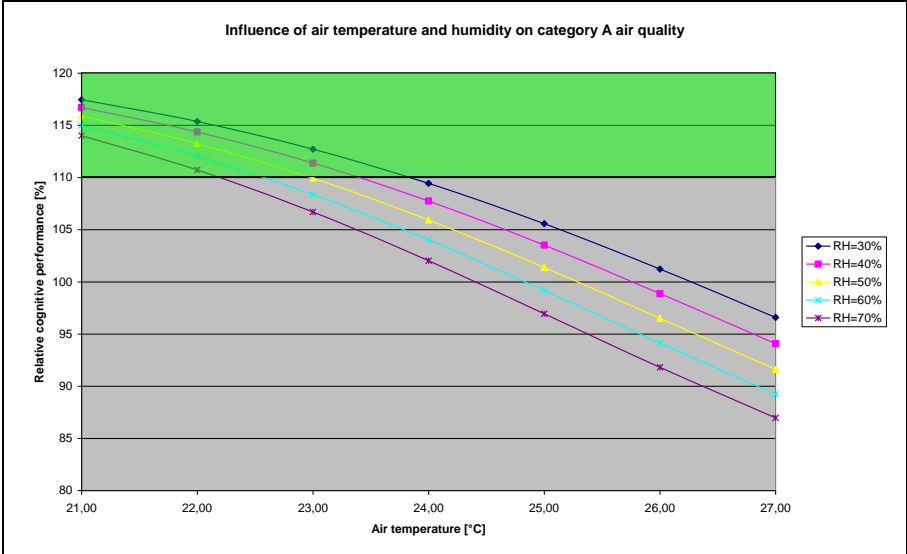

Figure 3.2.13. Influence of air temperature on category A air quality.

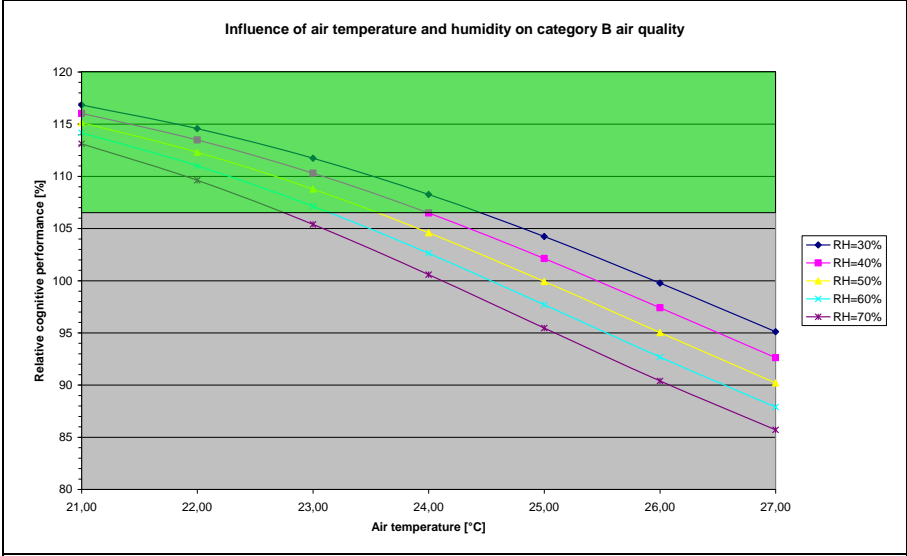

Figure 3.2.14. Influence of air temperature on category B air quality.

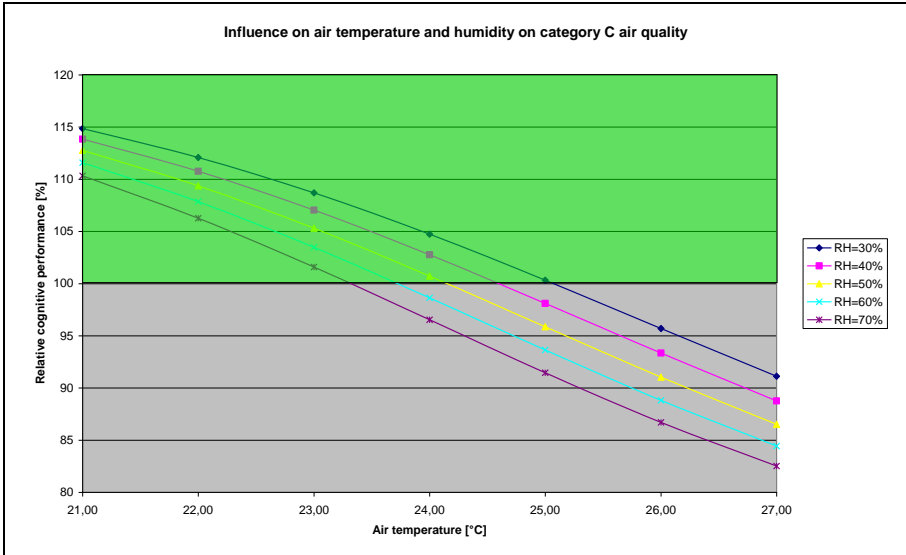

Figure 3.2.15. Influence of air temperature on category C air quality.

3.2.10 Influence of freshness on office activities

Wargocki et al. (150) have shown on the basis of a number of independent studies that air quality affects the performance of office work (Text typing, addition and proof reading). The research results of Wargocki are graphically shown in Figure 3.2.16.

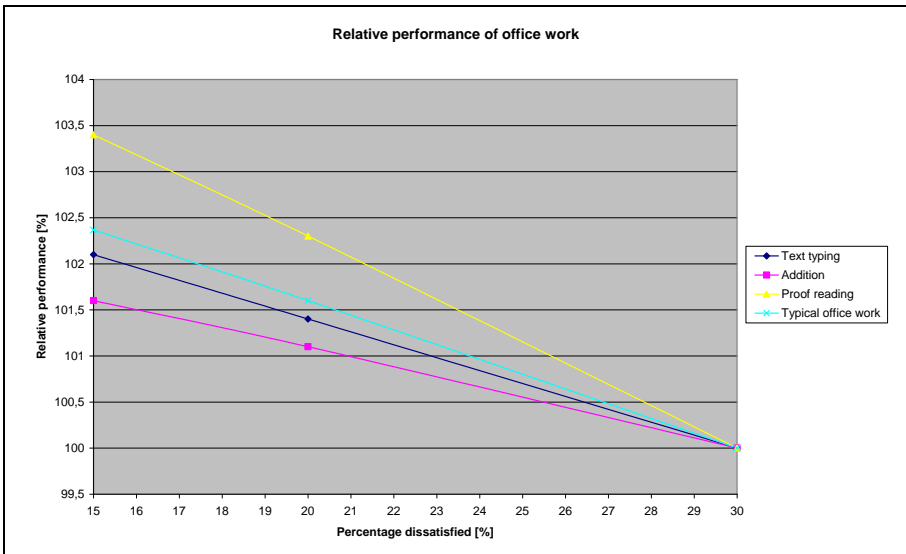

Figure 3.2.16. Relative performance of office work.

The research results in figure 3.2.16 can be displayed with the following trend lines:

- Text typing : $RP = -0.1400.PD + 104.20$ (12)
- Addition : $RP = -0.1071.PD + 103.22$ (13)
- Proof reading : $RP = -0.2271.PD + 106.82$ (14)
- Typical office work : $RP = -0.1581.PD + 104.75$ (15); mean of (12) to (14).

Herein is:

- RP = the relative performance [%]
- PD = the percentage of dissatisfied due to the perceived air quality [%].

Striking is the greater influence of the air quality on performance in the case of non-routine work, for which creative thinking is important (eg. Proof reading).

In figures 3.2.17-3.2.19 it is shown to what extent freshness affects creative thinking. The comfort area and their relative performance, depending on the category air quality, is shaded green in the charts.

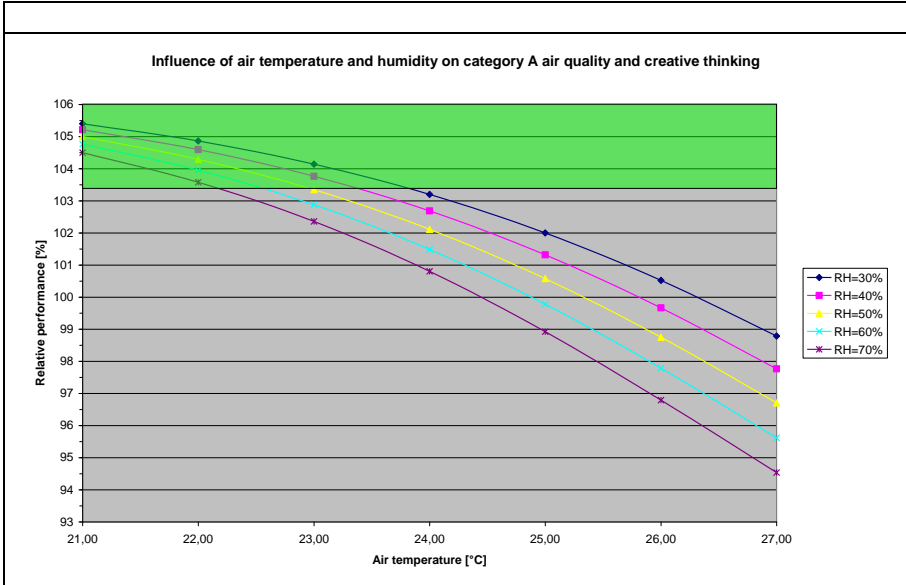

Figure 3.2.17. Influence of air temperature on category A air quality and creative thinking.

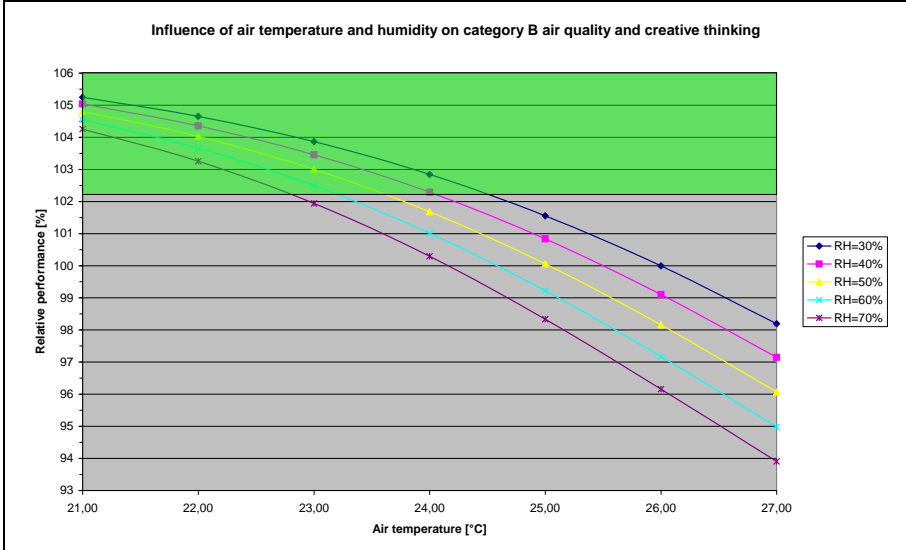

Figure 3.2.18. Influence of air temperature on category B air quality and creative thinking.

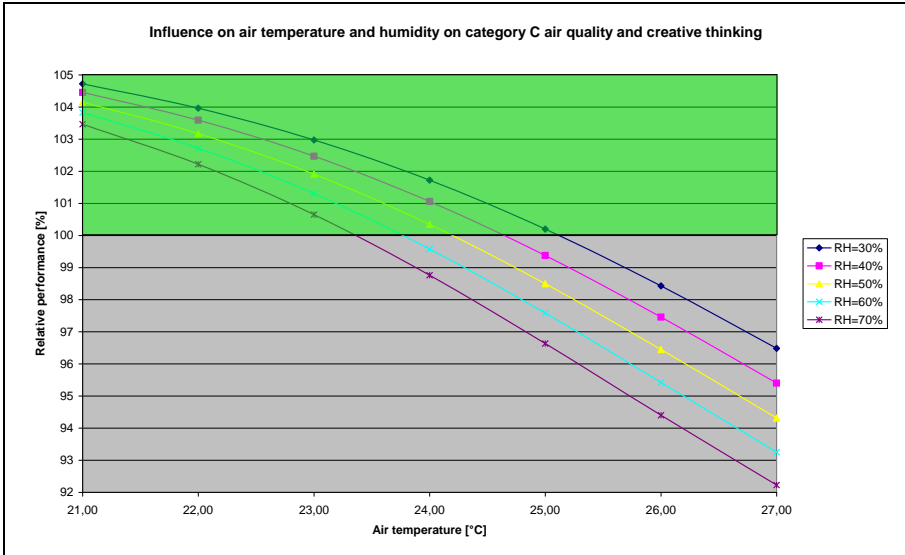

Figure 3.2.19. Influence of air temperature on category C air quality and creative thinking.

3.2.11 Freshness as a function of the carbon dioxide percentage versus of

In equation 9 the carbon dioxide level is not related to the air quantity per person, as proposed by Roelofsen (142), so some deviation can arise with equation 2 based on the pollution load in of. If this, assuming the equations 2 and 7, is done though then this results in a equation, applicable for metabolisms greater than or equal to 1.1 met, of which the results almost match the calculation results based on equation 2 (at full mixing); namely:

$$F = a + b.(30.2 - ta) + c.(42.94 - 0.01.pa) + d.\Delta CO_2^{1.356} \cdot V^{0.356} \quad (16)$$

Herein is:

- F = freshness of the air according to a seven point scale [0-6]
- ta = air temperature [°C]
- pa = vapor pressure [Pa]
- ΔCO_2 = the carbon dioxide level above outdoor [ppm]
- V = the inlet air quantity per person [m³/(h.pp)]
- a = 5.627
- b = -0.265; regression coefficient convective heat transfer
- c = -0.044; regression coefficient latent heat transfer
- d = 1.602.10⁻⁵; regression coefficient pollution load.

In an identical manner for a metabolism of 1.1 the following equation can be derived, on the basis of the equations 2 and 8:

$$F = a + b.(30.2 - ta) + c.(42.94 - 0.01.pa) + d.\Delta CO_2 \quad (17)$$

Herein is:

- F = freshness of the air according to seven point scale [0-6]
- ta = air temperature [°C]
- pa = vapor pressure [Pa]

- ΔCO_2 = the carbon dioxide level above outdoor [ppm]
- a = 5.627
- b = -0.265; regression coefficient convective heat transfer
- c = -0.044; regression coefficient latent heat transfer
- d = $0.04939 \cdot 10^{-2}$; regression coefficient pollution load.

One and other is, based on calculations, developed further in Tables 3.2.2 through 3.2.5.

Herein is:

- ΔCO_2 = the carbon dioxide level above outdoor [ppm]
- T_{air} = the air temperature [$^{\circ}\text{C}$]
- Fresh air = the air quantity per person [$\text{m}^3/(\text{h} \cdot \text{pp})$]
- PD_{CO_2} = the percentage of dissatisfied according to equation 16
- PD_{olf} = het percentage of dissatisfied according to equation 2
- $\text{PD}_{\text{cr1752}}$ = het percentage of dissatisfied according to equation 17.

Table 3.2.2. Percentage of dissatisfied due to the perceived air quality (Relative air humidity = 60%).

Fresh air [m ³ / (h·pp)]	Parameter	Metabolism [Met]																							
		1.1						3.0						6.0						10.0					
		T _{air} [°C]						T _{air} [°C]						T _{air} [°C]						T _{air} [°C]					
		21	23	25	27	21	23	25	27	21	23	25	27	21	23	25	27	21	23	25	27	21	23	25	27
20	ACO ₂	832																							
	PD ₀₀₂	11.8	22.1	31.7	56.7	-	-	-	-	-	-	-	-	-	-	-	-	-	-	-	-	-	-	-	-
	PD _{08r}	11.7	21.9	37.5	56.5	-	-	-	-	-	-	-	-	-	-	-	-	-	-	-	-	-	-	-	-
	PD _{08r82}	11.7	21.8	37.3	56.3	-	-	-	-	-	-	-	-	-	-	-	-	-	-	-	-	-	-	-	-
30	ACO ₂	555																							
	PD ₀₀₂	10.1	19.3	33.7	52.4	23.4	39.2	58.0	74.9	-	-	-	-	-	-	-	-	-	-	-	-	-	-	-	-
	PD _{08r}	10.1	19.2	33.6	52.3	23.7	39.6	58.3	75.1	-	-	-	-	-	-	-	-	-	-	-	-	-	-	-	-
	PD _{08r82}	10.1	19.1	33.5	52.2	16.6	29.5	47.2	66.0	-	-	-	-	-	-	-	-	-	-	-	-	-	-	-	-
40	ACO ₂	416																							
	PD ₀₀₂	9.4	18.0	31.9	50.3	17.9	31.6	49.7	68.1	-	-	-	-	-	-	-	-	-	-	-	-	-	-	-	-
	PD _{08r}	9.4	17.9	31.8	50.2	18.1	31.8	49.9	68.3	-	-	-	-	-	-	-	-	-	-	-	-	-	-	-	-
	PD _{08r82}	9.3	17.8	31.7	50.1	13.7	25.0	41.6	60.7	-	-	-	-	-	-	-	-	-	-	-	-	-	-	-	-
50	ACO ₂	333																							
	PD ₀₀₂	9.0	17.2	30.7	49.0	15.2	27.4	44.7	63.6	-	-	-	-	-	-	-	-	-	-	-	-	-	-	-	-
	PD _{08r}	8.9	17.2	30.7	48.9	15.3	27.6	44.9	63.8	-	-	-	-	-	-	-	-	-	-	-	-	-	-	-	-
	PD _{08r82}	8.9	17.1	30.6	48.8	12.1	22.6	38.4	57.4	-	-	-	-	-	-	-	-	-	-	-	-	-	-	-	-
60	ACO ₂	277																							
	PD ₀₀₂	8.7	16.7	30.0	48.1	13.5	24.8	41.4	60.4	30.8	48.4	66.7	81.3	-	-	-	-	-	-	-	-	-	-	-	-
	PD _{08r}	8.7	16.7	30.0	48.1	13.6	25.0	41.5	60.6	30.3	47.9	66.2	80.9	-	-	-	-	-	-	-	-	-	-	-	-
	PD _{08r82}	8.6	16.6	29.9	48.0	11.2	21.0	36.3	55.2	16.6	29	47.2	66.0	-	-	-	-	-	-	-	-	-	-	-	-
70	ACO ₂	238																							
	PD ₀₀₂	8.5	16.4	29.5	47.5	12.4	23.1	39.1	58.1	25.8	42.4	61.1	77.3	-	-	-	-	-	-	-	-	-	-	-	-
	PD _{08r}	8.5	16.4	29.5	47.5	12.5	23.2	39.2	58.3	25.4	41.9	60.6	76.9	-	-	-	-	-	-	-	-	-	-	-	-
	PD _{08r82}	8.5	16.3	29.4	47.4	10.6	20.0	34.8	53.6	14.8	26.9	44.0	63.0	-	-	-	-	-	-	-	-	-	-	-	-
80	ACO ₂	208																							
	PD ₀₀₂	8.4	16.1	29.1	47.1	11.7	21.8	37.4	56.4	22.5	38.0	56.6	73.9	-	-	-	-	-	-	-	-	-	-	-	-
	PD _{08r}	8.3	16.1	29.1	47.0	11.7	21.9	37.5	56.5	22.2	37.6	56.2	73.5	-	-	-	-	-	-	-	-	-	-	-	-
	PD _{08r82}	8.3	16.1	29.0	47.0	10.1	19.2	33.7	52.3	13.7	25.0	41.6	60.7	-	-	-	-	-	-	-	-	-	-	-	-
100	ACO ₂	166																							
	PD ₀₀₂	8.2	15.8	28.6	46.4	10.7	20.2	35.1	53.9	18.3	32.1	50.3	68.6	38.5	56.9	73.8	85.9	-	-	-	-	-	-	-	-
	PD _{08r}	8.1	15.8	28.6	46.4	10.7	20.2	35.2	54.0	18.1	31.8	49.9	68.3	37.9	56.3	73.9	85.6	-	-	-	-	-	-	-	-
	PD _{08r82}	8.1	15.7	28.5	46.3	9.5	18.2	32.2	50.6	12.1	22.6	38.4	57.4	16.6	29.5	47.2	66.0	-	-	-	-	-	-	-	-

Table 3.2.3. Percentage of dissatisfied due to the perceived air quality (Relative air humidity = 50%).

Fresh air [m ³ / (h,ppb)]	Para meter	Metabolism [W/m ²]															
		1.1			3.0			6.0			10.0						
		21	23	25	21	23	25	27	21	23	25	27	21	23	25	27	
20	AC _{O₂}	832															
	PD _{CO₂}	10.5	19.6	33.8	52.0	-	-	-	-	-	-	-	-	-	-	-	
	PD _{Air}	10.4	19.5	33.6	51.8	-	-	-	-	-	-	-	-	-	-	-	
30	AC _{O₂}	555															
	PD _{CO₂}	9.0	17.0	30.1	47.7	21.1	35.7	53.8	71.1	-	-	-	-	-	-	-	
	PD _{Air}	9.0	17.0	30.0	47.5	21.3	36.0	54.1	71.4	-	-	-	-	-	-	-	
40	AC _{O₂}	416															
	PD _{CO₂}	8.3	15.8	28.3	45.5	16.1	28.4	45.4	63.8	-	-	-	-	-	-	-	
	PD _{Air}	8.3	15.8	28.2	45.4	16.2	28.6	45.7	64.1	-	-	-	-	-	-	-	
50	AC _{O₂}	333															
	PD _{CO₂}	7.9	15.2	27.3	44.3	13.5	24.5	40.5	59.1	-	-	-	-	-	-	-	
	PD _{Air}	7.9	15.1	27.2	44.2	13.6	24.7	40.7	59.3	-	-	-	-	-	-	-	
60	AC _{O₂}	277															
	PD _{CO₂}	7.7	14.7	26.6	43.4	12.0	22.1	37.3	55.8	28.0	44.7	62.9	78.2	-	-	-	
	PD _{Air}	7.7	14.7	26.5	43.3	12.1	22.3	37.5	56.0	27.6	44.1	62.3	77.8	-	-	-	
70	AC _{O₂}	238															
	PD _{CO₂}	7.5	14.4	26.1	42.8	11.1	20.5	35.1	53.4	23.4	38.7	57.0	73.7	-	-	-	
	PD _{Air}	7.5	14.4	26.1	42.7	11.1	20.6	35.3	53.6	23.0	38.3	56.5	73.4	-	-	-	
80	AC _{O₂}	208															
	PD _{CO₂}	7.4	14.2	25.8	42.4	10.4	19.4	33.5	51.6	20.2	34.5	52.5	70.0	-	-	-	
	PD _{Air}	7.4	14.2	25.7	42.3	10.4	19.5	33.6	51.8	20.0	34.1	52.0	69.7	-	-	-	
100	AC _{O₂}	166															
	PD _{CO₂}	7.2	13.9	25.3	41.7	9.5	17.9	31.3	49.1	16.4	28.9	46.0	64.4	35.4	53.2	70.4	83.5
	PD _{Air}	7.2	13.9	25.2	41.6	9.5	17.9	31.4	49.2	16.2	28.6	45.7	64.1	34.8	52.6	69.9	83.1

Table 3.2.4. Percentage of dissatisfied due to the perceived air quality (Relative air humidity = 40%).

Fresh air [m ³ / (h·pp)]	Parameter	Metabolism [Met]																							
		1.1						3.0						6.0						10.0					
		T _{air} [°C]						T _{air} [°C]						T _{air} [°C]						T _{air} [°C]					
		21	23	25	27	21	23	25	27	21	23	25	27	21	23	25	27	21	23	25	27	21	23	25	27
20	ΔCO ₂	832																							
	PD _{CO2}	9.3	17.3	30.1	47.2	-	-	-	-	-	-	-	-	-	-	-	-	-	-	-	-	-	-	-	-
	PD _{OR}	9.3	17.2	30.0	47.0	-	-	-	-	-	-	-	-	-	-	-	-	-	-	-	-	-	-	-	-
	PD _{CHRS2}	9.2	17.1	29.8	46.8	-	-	-	-	-	-	-	-	-	-	-	-	-	-	-	-	-	-	-	-
30	ΔCO ₂	555						1513																	
	PD _{CO2}	8.0	15.0	26.6	42.9	19.0	32.3	49.6	67.1	-	-	-	-	-	-	-	-	-	-	-	-	-	-	-	-
	PD _{OR}	7.9	14.9	26.5	42.8	19.2	32.6	49.9	67.4	-	-	-	-	-	-	-	-	-	-	-	-	-	-	-	-
	PD _{CHRS2}	7.9	14.9	26.4	42.7	13.2	23.7	39.0	57.0	-	-	-	-	-	-	-	-	-	-	-	-	-	-	-	-
40	ΔCO ₂	416						1135																	
	PD _{CO2}	7.4	13.9	25.0	40.9	14.4	25.5	41.3	59.3	-	-	-	-	-	-	-	-	-	-	-	-	-	-	-	-
	PD _{OR}	7.3	13.9	24.9	40.8	14.5	25.7	41.5	59.6	-	-	-	-	-	-	-	-	-	-	-	-	-	-	-	-
	PD _{CHRS2}	7.3	13.9	24.8	40.7	10.8	19.8	33.7	51.3	-	-	-	-	-	-	-	-	-	-	-	-	-	-	-	-
50	ΔCO ₂	333						908																	
	PD _{CO2}	7.0	13.3	24.0	39.6	12.1	21.9	36.5	54.4	-	-	-	-	-	-	-	-	-	-	-	-	-	-	-	-
	PD _{OR}	7.0	13.3	24.0	39.5	12.1	22.0	36.7	54.6	-	-	-	-	-	-	-	-	-	-	-	-	-	-	-	-
	PD _{CHRS2}	7.0	13.3	23.9	39.5	9.6	17.8	30.7	47.9	-	-	-	-	-	-	-	-	-	-	-	-	-	-	-	-
60	ΔCO ₂	277						756						1513											
	PD _{CO2}	6.8	12.9	23.4	38.8	10.7	19.7	33.5	51.0	25.4	41.0	58.8	74.8	-	-	-	-	-	-	-	-	-	-	-	-
	PD _{OR}	6.8	12.9	23.4	38.7	10.8	19.8	33.6	51.2	25.0	40.5	58.3	74.3	-	-	-	-	-	-	-	-	-	-	-	-
	PD _{CHRS2}	6.8	12.9	23.3	38.7	8.8	16.5	28.8	45.7	13.2	23.7	39.0	57.0	-	-	-	-	-	-	-	-	-	-	-	-
70	ΔCO ₂	238						648						1297											
	PD _{CO2}	6.6	12.7	23.0	38.2	9.8	18.2	31.4	48.7	21.1	35.3	52.8	69.9	-	-	-	-	-	-	-	-	-	-	-	-
	PD _{OR}	6.6	12.6	22.9	38.2	9.8	18.3	31.5	48.8	20.7	34.8	52.3	69.5	-	-	-	-	-	-	-	-	-	-	-	-
	PD _{CHRS2}	6.6	12.6	22.9	38.1	8.3	15.6	27.5	44.1	11.8	21.4	35.9	53.8	-	-	-	-	-	-	-	-	-	-	-	-
80	ΔCO ₂	208						567						1135											
	PD _{CO2}	6.5	12.5	22.7	37.8	9.2	17.1	29.8	46.9	18.2	31.2	48.2	65.9	-	-	-	-	-	-	-	-	-	-	-	-
	PD _{OR}	6.6	12.4	22.6	37.7	9.3	17.2	30.0	47.8	17.9	30.8	47.8	65.5	-	-	-	-	-	-	-	-	-	-	-	-
	PD _{CHRS2}	6.5	12.4	22.6	37.7	7.9	15.0	26.6	42.9	10.8	19.8	33.7	51.3	-	-	-	-	-	-	-	-	-	-	-	-
100	ΔCO ₂	166						454						908						1513					
	PD _{CO2}	6.4	12.2	22.2	37.2	8.4	15.8	27.8	44.4	14.7	25.9	41.9	59.9	32.4	49.5	66.8	80.7	-	-	-	-	-	-	-	-
	PD _{OR}	6.4	12.2	22.2	37.1	8.4	15.8	27.9	44.5	14.5	25.7	41.5	59.6	31.8	48.8	66.2	80.2	-	-	-	-	-	-	-	-
	PD _{CHRS2}	6.4	12.2	22.2	37.1	7.5	14.1	25.3	41.2	9.6	17.8	30.7	47.9	13.2	23.7	39.0	57.0	-	-	-	-	-	-	-	-

Table 3.2.5. Percentage of dissatisfied due to the perceived air quality (Relative air humidity = 30%).

Fresh air [m ³ / (h·pp)]	Para meter	Metabolism [Meat]																							
		1.1						3.0						6.0						10.0					
		21	23	25	27	21	23	25	27	21	23	25	27	21	23	25	27	21	23	25	27				
20	ACO ₂	8.3	15.3	26.7	42.5	-	-	-	-	-	-	-	-	-	-	-	-	-	-	-	-				
	PD _{CO2}	8.2	15.2	26.5	42.3	-	-	-	-	-	-	-	-	-	-	-	-	-	-	-	-				
	PD _{olf}	8.1	15.1	26.4	42.1	-	-	-	-	-	-	-	-	-	-	-	-	-	-	-	-				
30	ACO ₂	7.0	13.2	23.5	38.4	17.0	29.1	45.3	62.7	-	-	-	-	-	-	-	-	-	-	-	-				
	PD _{CO2}	7.0	13.1	23.4	38.2	17.2	29.4	45.7	63.1	-	-	-	-	-	-	-	-	-	-	-	-				
	PD _{olf}	7.0	13.1	23.3	38.1	14.8	21.1	35.0	52.2	-	-	-	-	-	-	-	-	-	-	-	-				
40	ACO ₂	6.5	12.2	22.0	36.3	12.8	22.7	37.2	54.6	-	-	-	-	-	-	-	-	-	-	-	-				
	PD _{CO2}	6.5	12.2	21.9	36.2	12.9	22.9	37.5	54.9	-	-	-	-	-	-	-	-	-	-	-	-				
	PD _{olf}	6.5	12.2	21.8	36.2	9.6	17.6	30.0	46.6	-	-	-	-	-	-	-	-	-	-	-	-				
50	ACO ₂	6.2	11.7	21.1	35.2	10.7	19.4	32.7	49.6	-	-	-	-	-	-	-	-	-	-	-	-				
	PD _{CO2}	6.2	11.7	21.0	35.1	10.8	19.5	32.9	49.8	-	-	-	-	-	-	-	-	-	-	-	-				
	PD _{olf}	6.2	11.7	21.0	35.0	8.5	15.7	27.3	43.2	-	-	-	-	-	-	-	-	-	-	-	-				
60	ACO ₂	6.0	11.3	20.5	34.4	9.5	17.4	29.8	46.3	23.0	37.4	54.7	71.0	-	-	-	-	-	-	-	-				
	PD _{CO2}	6.0	11.3	20.5	34.3	9.6	17.5	30.0	46.5	22.6	36.9	54.1	70.5	-	-	-	-	-	-	-	-				
	PD _{olf}	6.0	11.3	20.4	34.3	7.8	14.5	25.5	41.0	11.8	21.1	35.0	52.2	-	-	-	-	-	-	-	-				
70	ACO ₂	5.9	11.1	20.1	33.8	8.7	16.1	27.8	43.9	18.9	31.9	48.6	65.7	-	-	-	-	-	-	-	-				
	PD _{CO2}	5.9	11.1	20.1	33.8	8.8	16.1	28.0	44.1	18.6	31.5	48.1	65.3	-	-	-	-	-	-	-	-				
	PD _{olf}	5.8	11.1	20.0	33.7	7.3	13.7	24.3	39.4	10.5	19.0	32.1	48.0	-	-	-	-	-	-	-	-				
80	ACO ₂	5.8	10.9	19.8	33.4	8.2	15.1	26.4	42.2	16.3	28.1	44.0	61.5	-	-	-	-	-	-	-	-				
	PD _{CO2}	5.8	10.9	19.8	33.4	8.2	15.2	26.5	42.3	16.0	27.7	43.6	61.1	-	-	-	-	-	-	-	-				
	PD _{olf}	5.7	10.9	19.8	33.3	7.0	13.2	23.4	38.3	9.6	17.6	30.0	46.6	-	-	-	-	-	-	-	-				
100	ACO ₂	5.6	10.7	19.4	32.8	7.4	13.9	24.5	39.7	13.1	23.2	37.8	55.2	29.6	45.7	62.9	77.5	-	-	-	-				
	PD _{CO2}	5.6	10.7	19.4	32.8	7.5	13.9	24.6	39.8	12.9	22.9	37.5	54.9	29.0	45.1	62.3	77.1	-	-	-	-				
	PD _{olf}	5.6	10.6	19.4	32.8	7.0	12.4	22.2	36.7	8.5	15.7	27.3	43.2	11.8	21.1	35.0	52.2	-	-	-	-				

For completeness in Table 3.2.6 a summary is shown of the calculated percentage of dissatisfied due to the perceived air quality if the influence of the enthalpy is not included in the evaluation (ergo. merely on the basis of the olf-decopolmethod and the equations 7 and 8; see chapter 3.2.8).

Herein is:

- ΔCO₂ = the carbon dioxide level above outdoor [ppm]
- PD_{CO2} = the percentage of dissatisfied according to equation 7
- PD_{olf} = het percentage of dissatisfied according to the olf-decopol-method
- PD_{cr1752} = het percentage of dissatisfied according to equation 8.

Table 3.2.6.

Percentage of dissatisfied due to the air quality. exclusive the influence of the enthalpy.

Fresh air [m ³ /(h.pp)]	Parameter	Unit	Metabolism [Met]			
			1.1	3	6	10
20	ΔCO_2	[ppm]	832	-	-	-
	PD _{CO₂}	[%]	23.9	-	-	-
	PD _{olf}	[%]	23.8	-	-	-
	PD _{cr1752}	[%]	23.5	-	-	-
30	ΔCO_2	[ppm]	555	1513	-	-
	PD _{CO₂}	[%]	17.7	43.3	-	-
	PD _{olf}	[%]	17.6	43.8	-	-
	PD _{cr1752}	[%]	17.4	34.8	-	-
40	ΔCO_2	[ppm]	416	1135	-	-
	PD _{CO₂}	[%]	14.1	36.8	-	-
	PD _{olf}	[%]	14.0	37.2	-	-
	PD _{cr1752}	[%]	13.8	29.0	-	-
50	ΔCO_2	[ppm]	333	908	-	-
	PD _{CO₂}	[%]	11.6	32.1	-	-
	PD _{olf}	[%]	11.5	32.5	-	-
	PD _{cr1752}	[%]	11.4	25.0	-	-
60	ΔCO_2	[ppm]	277	756	1513	-
	PD _{CO₂}	[%]	9.9	28.6	49.5	-
	PD _{olf}	[%]	9.8	28.9	49.4	-
	PD _{cr1752}	[%]	9.6	22.0	34.8	-
70	ΔCO_2	[ppm]	238	648	1297	-
	PD _{CO₂}	[%]	8.5	25.8	45.6	-
	PD _{olf}	[%]	8.5	26.1	45.5	-
	PD _{cr1752}	[%]	8.3	19.6	31.6	-
80	ΔCO_2	[ppm]	208	567	1135	-
	PD _{CO₂}	[%]	7.5	23.5	42.4	-
	PD _{olf}	[%]	7.4	23.8	42.3	-
	PD _{cr1752}	[%]	7.3	17.7	29.0	-
100	ΔCO_2	[ppm]	166	454	908	1513
	PD _{CO₂}	[%]	6.0	20.0	37.3	54.3
	PD _{olf}	[%]	5.9	20.3	37.2	54.2
	PD _{cr1752}	[%]	5.8	14.8	25.0	34.8

3.2.12 Fatigue as a function of the percentage of dissatisfied due to the perceived air quality.

In a research of Haneda et al. (35) (12 male subjects (age: 22.0 ± 1.7 years), concerning the combined effects of thermal environment and ventilation rate on productivity, a strong correlation between the percentage of dissatisfied due to the perceived air quality and the fatigue level was obtained. The evaluation of fatigue was based on Yoshitake's method (151), consisting thirty symptoms of fatigue (152). (153).

The relationship of the votes and the regression curve are shown in figure 3.2.20

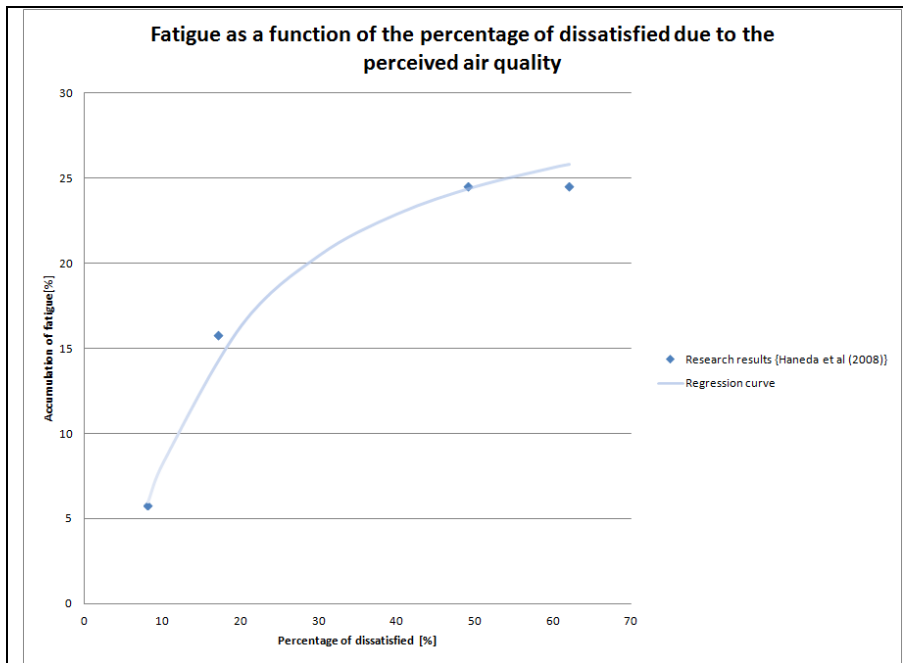

Figure 3.2.20. Percentage of dissatisfied with indoor air quality and the accumulation of the level of fatigue during a 350 minutes exposure (35).

The equation of the regression curve is derived in this study:

$$Y = \exp(3.469 - 13.43 / PD) \quad R^2 = 0.992; \sigma = 0.072.$$

Herein is:

Y = accumulation of fatigue [%]

PD = percentage of dissatisfied due to the perceived air quality [%].

3.2.13 Practice application

Office building

Within the framework of a second opinion on a recently completed new government office building in Amersfoort in the Netherlands with air quality complaints, an investigation was conducted. From the survey forms that users of the building had to fill in, it turned out that on 1 to 3 december, 10-12 december and 16 december 2013 the employees complained about the air quality, to warm situations and headaches.

In the figures 3.2.21 and 3.2.22 the percentage of dissatisfied is evaluated on the basis of the method, as described in the (NPR-)CR-1752 and on the basis of the model developed in this study based on the freshness of the air. Figure 3.2.21 is for the time interval of 30 November to 18 December, while figure 3.2.22 is only for 16 December. Figures 3.2.23 and 3.2.24 show the recorded air temperature and vapor pressure for 16 December.

The air temperature, air humidity and carbon dioxide concentrations are measured in the actual situation. The percentage of dissatisfied are calculated, according to NPR-CR-1752 and the evaluation method based on the freshness of the air.

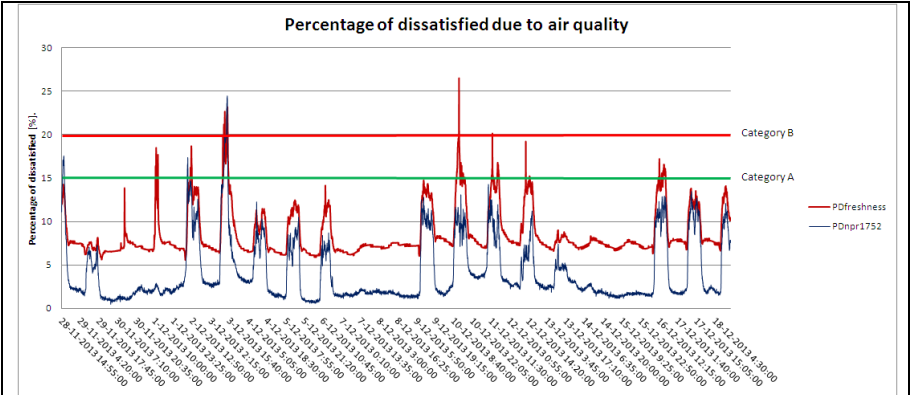

Figure 3.2.21. Actual situation (before adjustments).

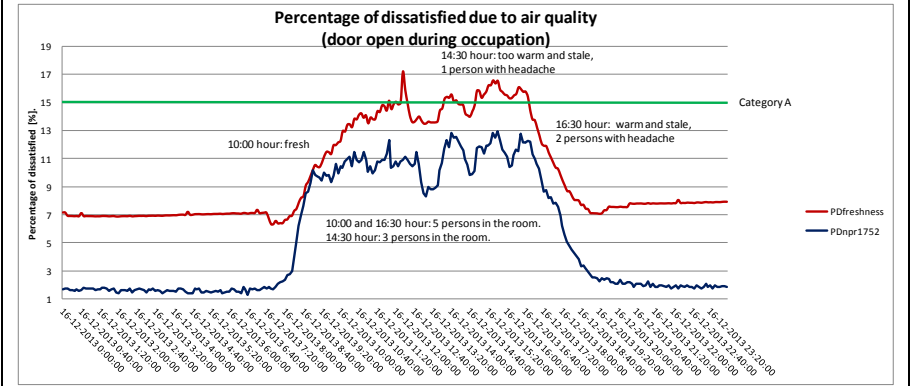

Figure 3.2.22. Actual situation (before adjustments) at 16-12-2013.

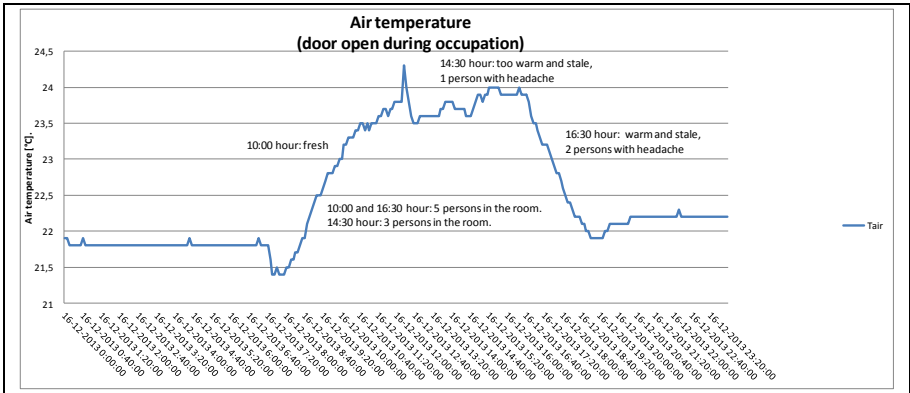

Figure 3.2.23. Air temperature at 16-12-2013.

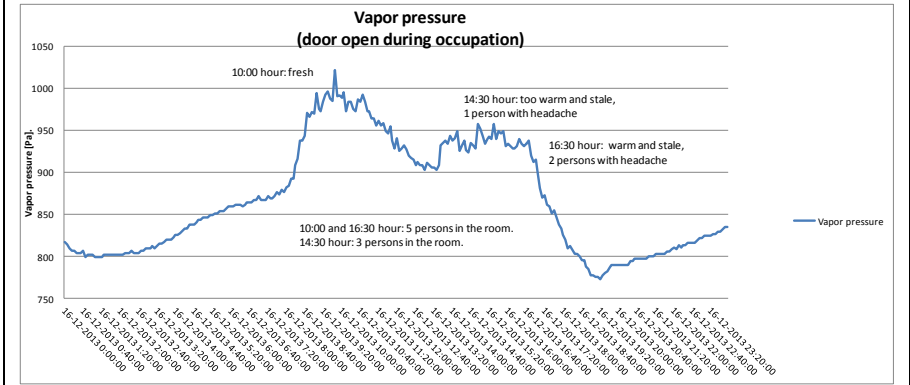

Figure 3.2.24. Vapor pressure at 16-12-2013.

The aforesaid complaints concerning the air quality are not well explained by the evaluation method of (NPR-)CR-1752 (blue curve in figures 3.2.21 and 3.2.22). The evaluation method based on the freshness of the air however fitted better with the complaints about the air quality on the aforesaid days (red curve in figures 3.1.21 and 3.2.22). In addition, it is noticeable that the curve of the percentage of dissatisfied, based on the freshness of the air, is higher than the percentage of dissatisfied, based on the CO₂-percentage, and is also better in line with the opinion of the users about the air quality in the building in general (i.e. stale). In figure 3.2.25 the situation after adjustments (namely a balanced ventilation system instead of a negative pressure ventilation system) in the same room is displayed. There are, in the current situation, indeed significant fewer reported complaints, as confirmed by the user and the owner of the building. The new method confirms that too. The evaluation method based on only the carbon dioxide concentration (according to NPR-CR-1752) presents however once again the opposite picture.

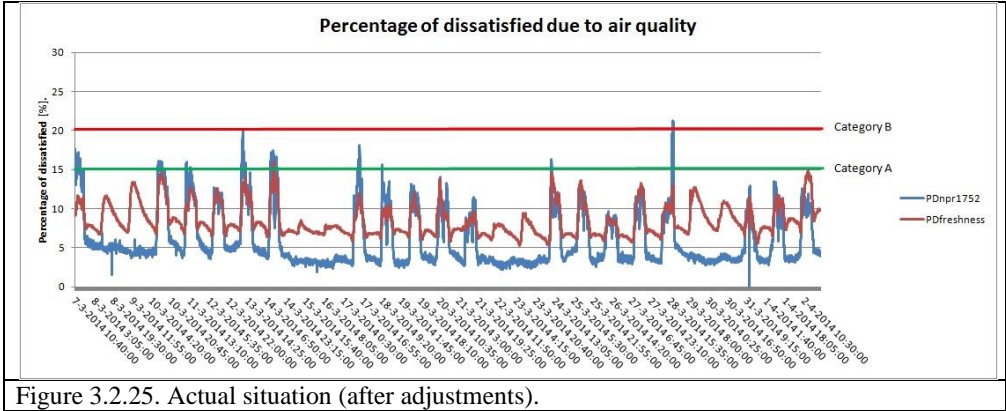

Figure 3.2.25. Actual situation (after adjustments).

Nursing home

The people in a nursing home complained about a stale indoor air quality. At entrance of the restaurant in the building the stale air quality was clearly noticeable. In order to explain and solve the problem climate measurements have been carried out over a period of one month. The calculation results, on the basis of the climate measurements, are shown in figure 3.2.26. Also in this situation, the complaints concerning the air quality were not well explained by the evaluation method of (NPR-)CR-1752 (blue curve in figures 3.2.26). The evaluation method based on the freshness of the air however fitted better with the complaints about the noticeable stale air quality in the building (red curve in figures 3.2.26).

The air temperature, air humidity and carbon dioxide concentrations are measured in the actual situation. The percentage of dissatisfied are calculated, according to NPR-CR-1752 and the evaluation method based on the freshness of the air.

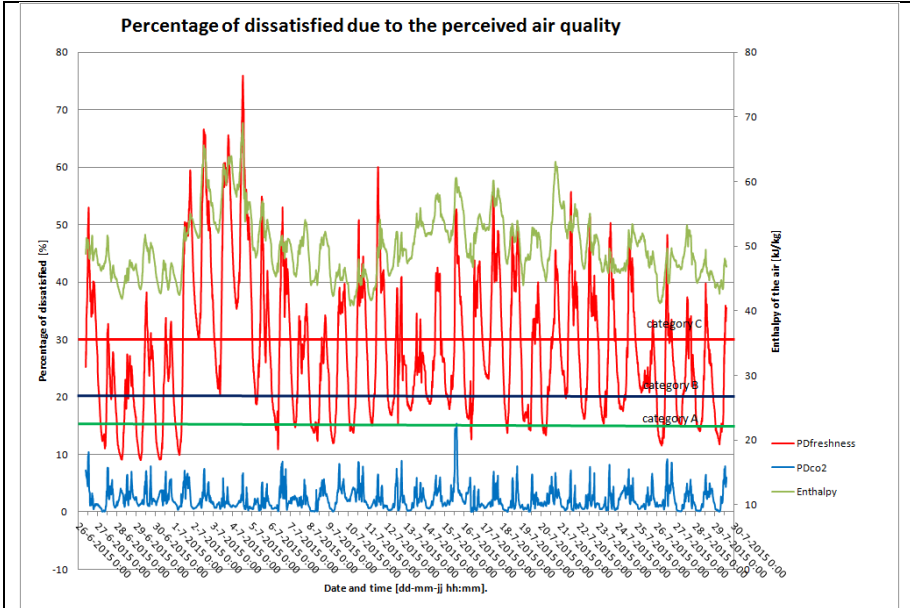

Figure 3.2. 26. Indoor air quality in the restaurant of a nursing home.

Table 3.2.7. Nursing home - statistical survey climate measurements.

	Air temperature	Relative air humidity	CO ₂ -concentration
	[°C]	[%]	[ppm]
Minimum	21.8	26.4	324
Maximum	30.6	66.8	795
Mean	25.5	46.6	396
Standard deviation	1.7	7.6	50

3.2.14 Conclusion

On the basis of this study, the following is concluded:

- The freshness of the air, polluted by people, is quite accurately calculated on the basis of the air temperature, the relative air humidity as well as the quotient of the amount of air pollution and the fresh air supplied
- As proposed by Clements-Croome (143) it turns out to make sense to involve the freshness of the air in the evaluation of the perceived air quality, so the influence of air temperature and air humidity is taken into account
- The freshness of the air and the acceptance of the air quality are determined by the air temperature, the vapor pressure and the air pollution; and in terms of influence, in particular, in that order. This is also apparent from the examination of Fang et al. (139), (145)
- The calculated percentage of dissatisfied due to the perceived air quality, on the basis of the olf-decipolmethod of Fanger, without the influence of the temperature and humidity of the air, is about the average of the percentages calculated on the basis of the method as shown in this study
- The calculation results in Tables 3.2.2 through 3.2.6 show that with an increase in metabolism and at rising air volumes (with a constant CO₂-concentration difference) also increases the percentage of dissatisfied and is larger than one would expect on the basis of the

CO₂ concentration difference (see the PDco₂-values and PDolf-values) under the shaded cells in the Tables). This corresponds to one of the conclusions from the research by Rasmussen (135), (142)

- In general one prefers indoor air with an average score for the freshness lower than 2.6 (i.e. 15% dissatisfied), according to the seven point scale used here [0-6]
- Depending on the desired level of air quality the percentage of dissatisfied due to the perceived air quality as well as the (learning) performance, especially at an air temperature higher than ca. 23 to 24° C is significantly negative affected by the freshness of the air
- The need for fresh air implies a preference for radiant heating and cool designing above convective heating, which will result in a more pleasant indoor air quality and reduce the use of energy
- If a climate control system is deliberately designed on the basis of temperature transgressions, one needs to realize that the temperature transgressions strongly affect the freshness of the air and thus the percentage of dissatisfied due to the perceived air quality. The evaluation of the thermal indoor climate and the perceived air quality are in that situation not to be considered independently of each other
- If a climate control system is designed on the basis of temperature transgressions one should execute, in the design stage, not only temperature transgression calculations but also transgression calculations of the percentage of dissatisfied due to the perceived air quality to evaluate the indoor environment correctly. Ergo, this means another way of designing than is usual in the current professional practice
- The method described here lends itself to examine the perceived air pollution (in olf) by persons, based on a few relatively simple measurements of environmental parameters without having to use a group of trained people on air quality (so called odor panels) (142).
- This method leads to a simplification of an in practice to perform air quality research, as long as there is no handy and reliable measuring device available for the measurement of the perceived air quality (142)
- The extent to which the air velocity and air flow direction on facial height possibly affect the freshness of the air needs to be further examined.

3.2.15 Acknowledgments

Thanks are due to dr. L.G. Berglund for his interest and help during this work as well as for reviewing and editing of this chapter.

4 Noise

4.1 Improvement and application of the relationship between the performance loss in open office spaces due to noise by speech

ABSTRACT. The purpose of this chapter is to show how the performance of the personnel can be negatively affected by conversations, adjacent to the working space, in an open-plan office environment. Using two scientific mathematical models it is possible to quantify the performance losses, as a result of adjacent conversations, with various desk layouts in an open-plan office. The results obtained from the underlying unique Finnish study, based on a gathering of studies, can be improved by applying a regression analysis to the recorded research results. A similar study of more recent date is not found in the literature. The in this chapter modified deviation formula, in our opinion, not only corresponds more closely to the research results, but produces a better translation of the speech transmission index to the intelligibility qualifications, as shown in the guideline NPR 3438 (154). It is reasonable to conclude that performance loss, as a result of a poor acoustic situation, can be related to the speech intelligibility in a space. The relationship between the speech transmission index and performance loss makes it possible to design on the basis of productivity improvement, resulting in a comfortable acoustic working environment and a consistent financial advantage for the organisation.

Keywords

Productivity, performance, noise, acoustics, speech, transmission, intelligibility, open-plan offices, separation screens, STI.

4.1.1 *Introduction*

More and more people are currently employed in the services sector and spend most of their working days inside a building. A working environment which is as healthy and comfortable as possible is therefore not unimportant, if people are to function undisturbed and at their best within an organisation.

Noise, especially in an enclosed space, is an important aspect which affects both the feeling of “well-being” and concentration in regard to functional performance. Personnel costs are of a significantly higher factor than the costs for organisational accommodation, therefore any productivity losses, expressed in financial terms, clearly represents large amounts of money. Noise is often defined as undesired sound. Any sound, however, that is disturbing is, in principle, noise. This can often mean that it is not the particular sound or the magnitude of the sound which is defined as noise, but the perception of the sound by the subject listener to which extent the sound is experienced as noise. This is also relative to the working circumstances at that moment in time. Every day noise or noise within a noisy environment can be described as noise when it disturbs or affects the capacity of the person to perform the working function.

Noise causes personnel to become irritated and interrupted and to perform less well, especially in situations requiring creativity and thought, and may cause, occasionally, short term memory loss. Noise has a negative and often a slowing down effect upon performance and memory. Noise in offices is a problem which is, currently and unfortunately, rarely recognised by the management in a corporate organisation (155).

Two major reasons for the increase in objectionable noise in the work place can be blamed upon the introduction of open-plan offices and the transformation of formerly closed office work areas into transparent and open character work areas. Magnification of the problem has been caused by the intensification of the occupancy levels and the use of speaker enabled telephone and computer communications.

This chapter will show, by means of two scientific models, how the performance of the personnel can be negatively affected by conversations, adjacent to the working space, in an open-plan office environment.

4.1.2 *The open-plan office*

Office spaces can be roughly divided into two categories.

Open office spaces with high concentration levels of work areas (see figures 4.1.1 and 4.1.2), subdivided, or not, by screens and filing cabinets and, conventional individual compartmentalised offices separated from each other.



Figure 4.1.1. Open office space.

Open-plan offices are often preferred, partly because the working areas within the office space are 50% smaller than in conventional, individual, office accommodations.

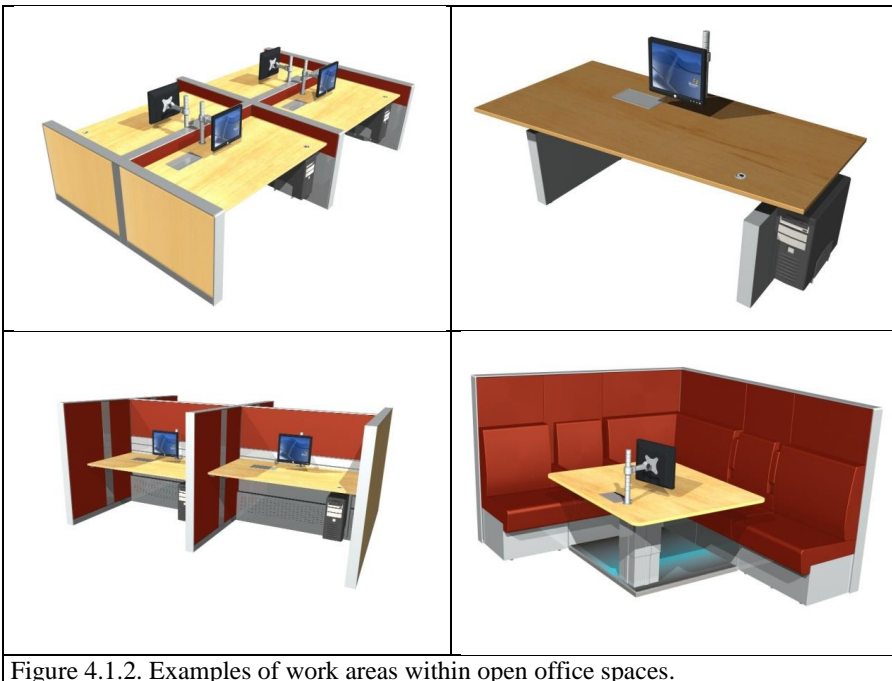

Figure 4.1.2. Examples of work areas within open office spaces.

Alterations to the layout within open offices are simpler to carry out. An open-plan office is also easier to rent. Furthermore, the economic advantages of open-plan offices can be improved by the following:

- The shorter working distances

- The promotion of better:
 - communications
 - information routes
 - colleague relations
 - work involvement
 - transparency and openness
 - fresh and modern architecture.

Undesirable acoustic consequences – due to, for example, lack of speech privacy and reduced concentration as an outcome of overhearing other conversations - are often ignored, or not taken seriously, during strategic accommodation decisions, because of the apparent advantages of the open-plan office economics and organisational benefits; since it is expected that the personnel will, in due course, adjust to the new office noise situation.

From various studies, it has been shown that speech (incidental and/or formal meeting discussions, telephone conversations etc.) form the most disturbing source of noise in an open office accommodation. The disturbance is not, apparently, due to any increase of speech volume, whether individually or due to a multitude of voices speaking simultaneously but, and in particular, as a result of over-hearing a conversation which is distracting. Studies reveal that once a person has been distracted it will take ten minutes or more for that person to return to the same concentration level they were at before the distraction. In practice, every day, in an open-plan office, there are virtually constant conversations which can be of a disturbing nature (156). The reduction of the speech intelligibility disturbance between various working areas in open-plan offices takes on great importance.

4.1.3 Speech intelligibility versus Speech privacy

Speech Intelligibility

The speech intelligibility in a space can be evaluated on the basis of the STI (Speech Transmission Index) as mentioned in NEN-EN-ISO-9921 (157). The STI is a measurable and calculable value for the speech intelligibility, whereby the values vary between 0 (not intelligible) to 1 (perfectly intelligible). Speech is modulated by a test signal which has particular speech characteristics; given that speech can be described as a broad band white noise modulated with particular fluctuation frequencies. At the receiver location, the modulation depth of the received signal, over various frequency bands, is compared to the test signal transmitted. The speech intelligibility is related to the reduction in the modulation depth.

Speech privacy

Speech privacy is the complete opposite of speech intelligibility and can best be shown on the basis of the Privacy Index, as follows:

Privacy Index = 1 – Speech transmission index [-].

The relationship speech transmission index, speech intelligibility and speech privacy is shown in Table 4.1.1.

Table 4.1.1. Translation STI to the intelligibility qualities, NPR 3438 (154).

STI [-]	Speech intelligibility	Speech privacy
0.00 – 0.30	Bad	Good
0.30 – 0.45	Poor	Reasonable
0.45 – 0.60	Reasonable	Bad
0.60 – 0.75	Good	Very bad
0.75 – 1.00	Excellent	No

For an good speech privacy, a speech transmission index equal to or smaller than 0.2 is advised (158). In order to evaluate the speech intelligibility between two adjacent working areas, whether or not separated by a sound barrier, this study uses the Cope-Calc validated computerprogram of the National Research Council Canada (159) based on the Wang and Bradley model (160).

4.1.4 Other influential aspects

When reading, the sounds of a conversation are only a disturbance if there is a similarity between the text being read and the content of the conversation, and not by the loudness of the speech. Conversations have a more negative influence than any back ground noise, if the conversation concerns a recognisable subject.

Conversations that one cannot follow, for example in a foreign language, are much less disturbing. Noise can also have a negative influence on the memory. Conversational noise makes memory retention more difficult. Other sorts of noises are disturbing but to a lesser extent. Performance studies carried out in noisy situations but with a good acoustic environments do not always reveal large differences. This can be answered by understanding that one compensates and subdues daily and familiar background noises by a higher level of concentration. However, this very often results in tiredness, lack of comprehension and irritation. One performs less well and cooperation is poorer with colleagues (155).

Human beings have an almost instinctive reaction to sound. There is always a reaction to a new sound and this causes a lack of focus in the activity being carried out.

The consequences can be that important details are overlooked and/or the creative thought processes are detrimentally disturbed (155).

Mans sensory perceptions keep a persons active and subconsciously aware of what is occurring around them, but only to a certain level. Above this level, any disturbance is disruptive. The disturbance level is variable from person to person and is dependent upon the work activity, the situation, other overriding sensory impressions etc. Sound can also result in performance improvement. Certain monotonous manual work, such as painting and decorating and production line work can perceive sound as acceptable. Conversely, more difficult tasks demand concentration. The activity level of an individual is also influenced by personal circumstances, such as health, sleep, drugs, medications, work pressures etc (155).

Noise becomes a disturbance when one is deciding how to carry out a particular activity. Unwelcome noise causes one to diminish the value of and ignore available information. The result is that the activity is not always performed in the best manner (155).

Noise is an influence on strategic solutions to a problem. If one is affected by noise, human nature chooses the simplest most favoured strategy, even when, subsequently, circumstances change and the noise disappears (155)

Noise increases working pressure. A problem that could be solved by using a little more effort may be carried out, but less effectively, despite every intentions of more effort (155).

Noise reduces performance capability, even when the noise has subsided and may later result in tiredness, irritability and depression (155).

Noise disturbs verbal communication and makes speech and hearing less distinct. A noisy environment demands more effort to speak and listen. The difficulty is increased when the listener must also remain concentrated on their work (155).

4.1.5 Performance loss

It is reasonable to conclude that performance loss, as a result of a poor acoustic situation, can be related to the speech intelligibility in a space. For this purpose, the research results from the Institute of Occupational Health in Finland (42) are used. A summary of the results from this unique Finnish study, a collection of studies regarding the relationship between speech intelligibility and performance loss, show that the performance loss varies between 4 and 45%, dependent upon the task. The best performance was shown to occur when there was no speech present (STI=0) and the largest performance loss occurred when speech was perfectly intelligible (STI=1). Between these two extremes, the assumption is that, the performance loss, as a function of the speech intelligibility, in principle, follows a similar curve to the subjective speech intelligibility, as a function of the speech transmission index, conforming to IEC 60268-16 with a maximum of 7%, which is the minimum performance loss, within the parameters of the previously mentioned inventory for proofreading (see the red curve with squares in figure 4.1.3).

In the Finnish study, the model was not influenced by a regression analysis of the research results. Consequently, and for this presentation, it seems sensible to perform a regression analysis upon the results in order to evaluate the extent to which this may affect the eventual model. The results are graphically shown in figure 4.1.3 and the blue curve with circles illustrates the influence of the regression analysis.

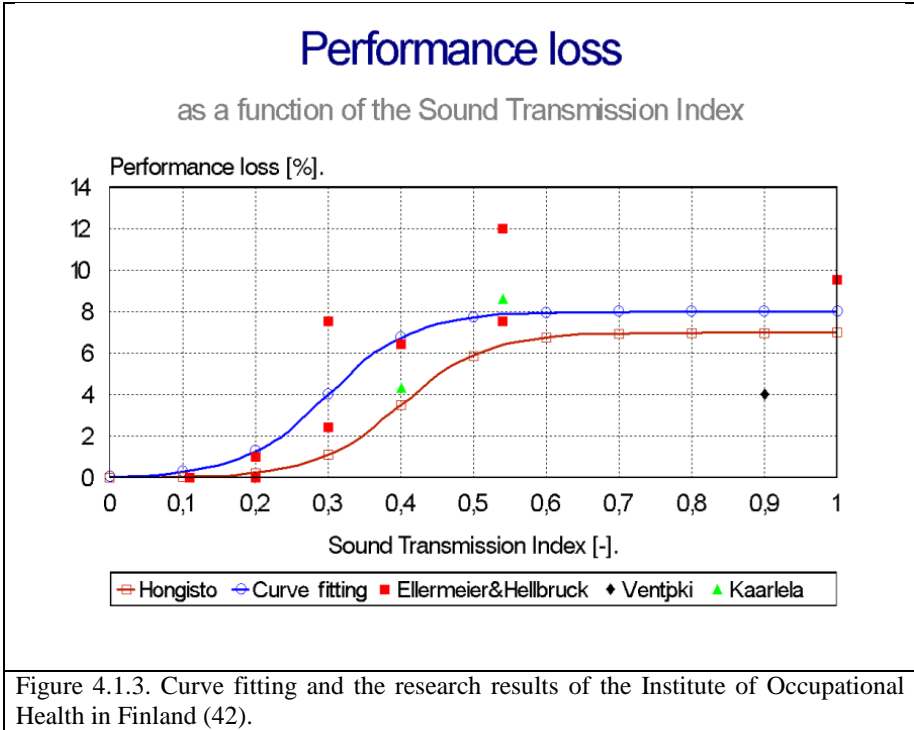

By means of the Boltzmann sigmoid function, which is advised in the previously mentioned study, the deviation in the prediction model due to regression analysis conforms to the following formula (see blue curve with circles in figure 4.1.3):

$$DP = 8.04 * (1 - 1 / (1 + \text{EXP}((\text{STI} - 0.304) / 0.054))), R^2=0.693, \sigma=2.24.$$

Where:
 DP = performance loss [%]
 STI = speech transmission index [-].

The maximum of the modified deviation formula appears to be somewhat higher than the Finnish study. Larger differences are also apparent between the speech transmission indexes 0.2 and 0.5. In our opinion, the application of this deviant formula not only corresponds more closely to the research results but produces a better translation of the speech transmission index to the intelligibility qualifications, as shown in the NPR 3438 (154). The model should be further developed by continuing the studies of Ellermeier & Hellbrück and Venetjoki et al. as mentioned in the Finnish study. For the record it is pointed out that culture may be of influence. This should be further investigated too in future research.

4.1.6 Situation under consideration

To obtain an impression of the performance loss by an employee in an open-plan office situation, a calculation study has been carried out. An open work area is considered, as shown in figure 4.1.4, whereby the screen height, the sound absorption coefficient of the ceiling and the background noise levels are variables. In order to remain in line with the previously men-

tioned Finnish study, their proposed prediction model is used instead of the modified deviation function.

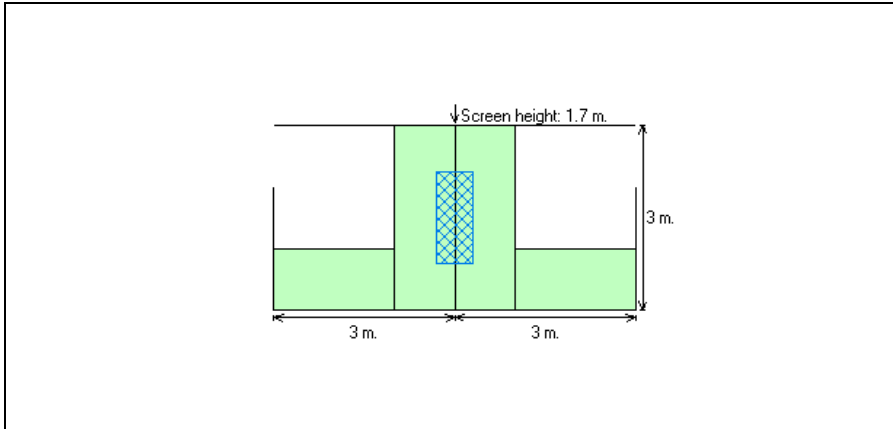

Figure 4.1.4. Plan considered work station diagram (top view): Two desks opposite of each other; lights (open grill) over screen.

4.1.7 Calculation results

The calculated results are shown graphically in the figures 4.1.5 to 4.1.7.

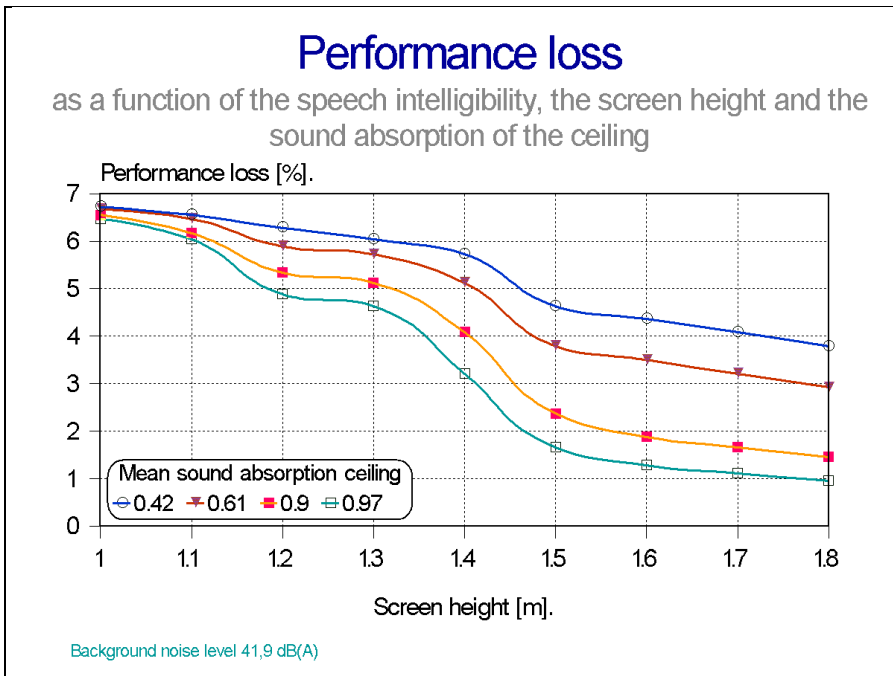

Figure 4.1.5. Summary of calculated results (this study).

Performance loss

as a function of the speech intelligibility, the screen height and the sound absorption of the ceiling

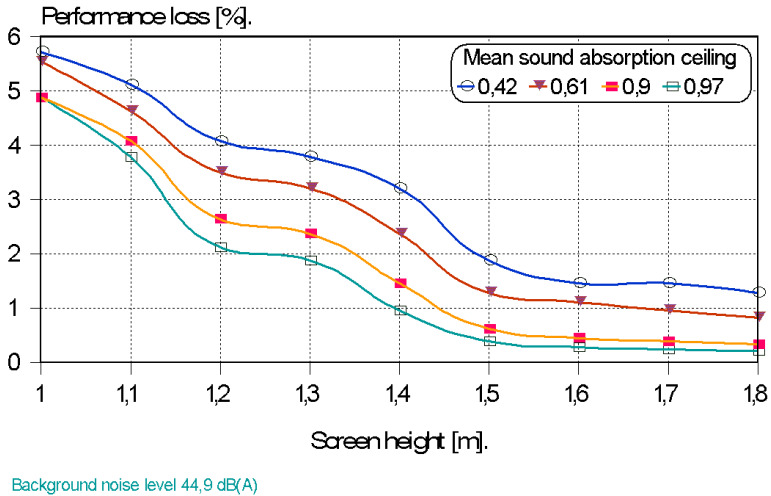

Figure 4.1.6. Summary of calculated results (this study).

Performance loss

as a function of the speech intelligibility, the screen height and the sound absorption of the ceiling

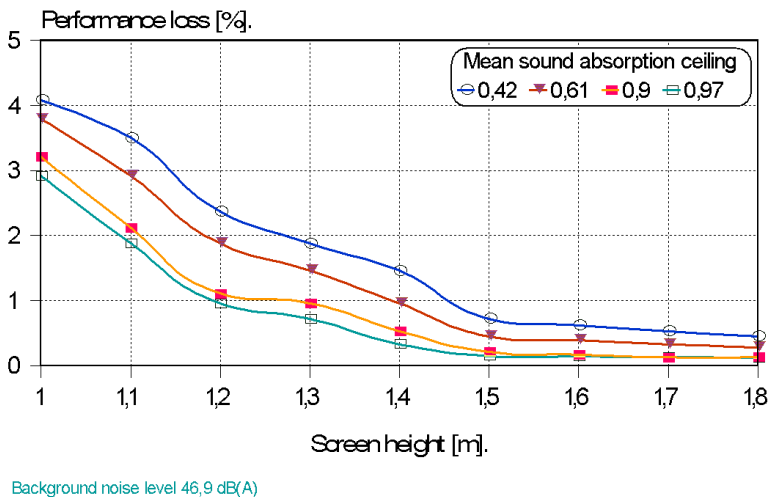

Figure 4.1.7. Summary of calculated results (this study).

4.1.8 Conclusions

Based upon of the observations, the following can be concluded:

- Using the relationship between the speech transmission index and performance loss in combination with the Wang & Bradley model it is possible to quantify the performance losses, as a result of adjacent conversations, with various desk layouts in an open-plan office.
- The results obtained from the Finnish study can be improved by applying a regression analysis to the recorded research results.
- The modified deviation formula, in our opinion, not only corresponds more closely to the research results, shown in figure 4.1.3, but produces a better translation of the speech transmission index to the intelligibility qualifications, as shown in the NPR 3438 (154).
- The maximum performance loss for office workers influenced by intelligible adjacent conversations would be approximately 8%, using the modified deviation formula.
- By applying the modified deviation formula, the curves shown in figures 4.1.5 to 4.1.7 would be drawn somewhat higher in the graphical representation.
- Especially for the speech transmission index interval between 0.2 and 0.5, the modified deviation formula produces a larger off-set compared with the Finnish study.
- The speech transmission index should be lower than 0.5 to produce any positive influence upon performance.
- In order to obtain acceptable conversation privacy, a speech transmission index lower or equal to 0.2 is advised. (158).
- An increase in background noise level causes a worsening of the speech intelligibility of the participants and a decrease in performance loss. An open-plan office requires a minimum background noise level of 45 dB(A), where potentially disturbing conversations/discussions are carried on. The background noise level may, however, never be higher than 48 dB(A) (158).
- Practically speaking, this means that ceilings with very good sound absorbing qualities together with high separation screens should be used in order to mask speech sounds. Without these measures, a good speech privacy is impossible in an open-plan office environment.
- Other general measures to limit or prevent noisy activities will improve speech privacy and increase performance.
- In addition, it is strongly recommended that during the design of an open-plan office environment, the incorporation of smaller closed office spaces should be planned, where employees may retreat for telephone conversations or to carry out activities which require more creativity and/or accuracy.

4.2 A new methodology for the evaluation of environmental noise based upon the percentage of dissatisfied

ABSTRACT. This chapter is a proposal and a first step to develop a method to evaluate and classify environmental noise, conforming to NEN-EN-15251 (23) and NPR-CR-1752 (22), in a built-up area based upon the percentage of dissatisfied related to the equivalent background noise. In the Dutch/European practical recommendations NPR-CR-1752 and the EN-15251 three categories of the indoor environment in buildings are prescribed (category A, B and C). In the recommendations, the limit whereby the percentage of dissatisfied should remain under varies in each category for both the thermal indoor environment and the air quality. The categories for noise and illumination criteria are not yet explicitly related to a percentage of dissatisfied. Using the percentage of dissatisfied as the evaluation criterion, when related to the equivalent background noise, produces a more refined evaluation of comfort than an evaluation based upon the percentage of seriously disturbed or the effects of sleep deprivation in relation to external noise. Furthermore, this corresponds to the European standards and recommendations concerning quality grouping of the indoor environment, based upon the percentage of dissatisfied. Based upon recent European undertakings concerning the development of categories for the indoor environment based upon the percentage of dissatisfied, it is desirable to utilise these categories to noise aspects too, and to relate it to the equivalent background noise level.

Keywords

Environmental noise, noise control, dissatisfied, discomfort, EN 15251, CR 1752, comfort categories, environmental regulations.

4.2.1 Introduction

With the noise level it is possible to make a judgement of the results upon the indoor environment caused by environmental noise via of a, so-called, “dose-effect relationship”. The “dose-effect relationships” are determined from reaction responses obtained from people who have been subject to the noise level. In general, these reaction studies have been used to determine “percentages of seriously disturbed” and the percentage of the population that would suffer sleep deprivation related to outdoor noise levels (161). It now appears that these earlier reaction studies do not correspond with the present situation. This is, for example, the case of the “dose-effect relationships” caused by air traffic noise, tabulated in Ke (Kosten - units) (162), (163) and as a consequence, there even exists a movement to remove the legal protection caused by the noise from Schiphol airport (164). For the good order the reaction study for the Ke, carried out in 1962 and 1963, was performed using about 1000 residents living adjacent to, the formerly known, Schiphol airport (162).

In practice, within the housing proces, it is desirable to divide the aspects of the indoor environment into quality categories (165), (166). In the present situation it seems that a classification for noise and sound insulation according to, for example, NEN-1070 (167) may be a more practical approach. The classification in this standard is, principally, based upon an interval subdivision of the percentage of disturbed by noise together with an associated qualification description (see annex C in NEN-1070). However, in view of European developments (e.g. CR-1752 (22), EN-15251 Ontw. (168) en (NEN-)EN-15251 (23)) considering classification of the indoor environment based upon the percentage of dissatisfied, it makes sense to use this parameter for the evaluation of noise too.

In the European guideline CR-1752 and the European standard EN-15251 three categories of the indoor environment in buildings are prescribed (category A, B and C). In the recommendations, the limit whereby the percentage of dissatisfied should remain under varies in each category for both the thermal indoor environment and the indoor air quality. The criteria in the categories for the aspects noise and light are not yet explicitly related to a percentage of dissatisfied. The abovementioned guideline and standard are very important to the field of study because it makes sense to use them in, especially performance based, contracts and programs of requirements within the housing proces. Most clients within the housing process have no affinity with arguments like Lden, LAeq or whatsoever. However the argument Percentage of Dissatisfied is understood by everyone.

This chapter formulates therefore an idea and proposes a method, in line with the European developments regarding indoor environments, for the evaluation and classification of environmental noise in the built environment by means of the percentage of dissatisfied.

4.2.2 Road traffic noise and the percentage of dissatisfied

In a collective study carried out by two departments within the University of Lyngby in Denmark (169), under conditioned circumstances in two climate chambers, the relative influences of air quality, noise and thermal effects were investigated in regard to discomfort. In one of the climate chambers one set of subjects were exposed to various thermal effects and air quality levels. At the same time and for each of the variable situations, in the second climate chamber, a second set of subjects were exposed to various noise levels, comparable to a road traffic noise level spectrum, but in a thermally neutral and good air quality environment, to investigate to which extent the noise level caused the same level of discomfort. In all 68 comparable studies were carried out in the climate chambers with the same group of 16 subjects (8 men and 8 women; seated; typical indoor winter clothing).

In the aforementioned study the analytical relationship of the percentage dissatisfied (169) for equivalent noise levels was not fully worked out, i.e.

$$PD_{\text{noise}} = 4.35 \int_{-\infty}^{\text{noiselevel}} \exp\left(-\left(\frac{x-58.6}{13.0}\right)^2\right) dx [\%].$$

4.2.3 Numerical approximation method

The above integral is, with the aid the Simpson integration rule, calculable.

By regression analysis of the calculated results and the application of a Boltzmann-Sigmoid function, as a starting point, it is possible to create the following function:

$$PD_{\text{noise}} = 101.12 - 101.70 / [1 + \exp\{(L_{\text{Aeq}} - 58.56) / 5.40\}] [\%]; \{R^2=1\}.$$

Where:

PD_{noise} = percentage of dissatisfied as a result of road traffic noise; $0 \leq PD_{\text{noise}} \leq 100$ [%]

L_{Aeq} = the A weighted equivalent background noise level as a result of road traffic noise [dB(A)].

Both functions are shown in figure 4.2.1.

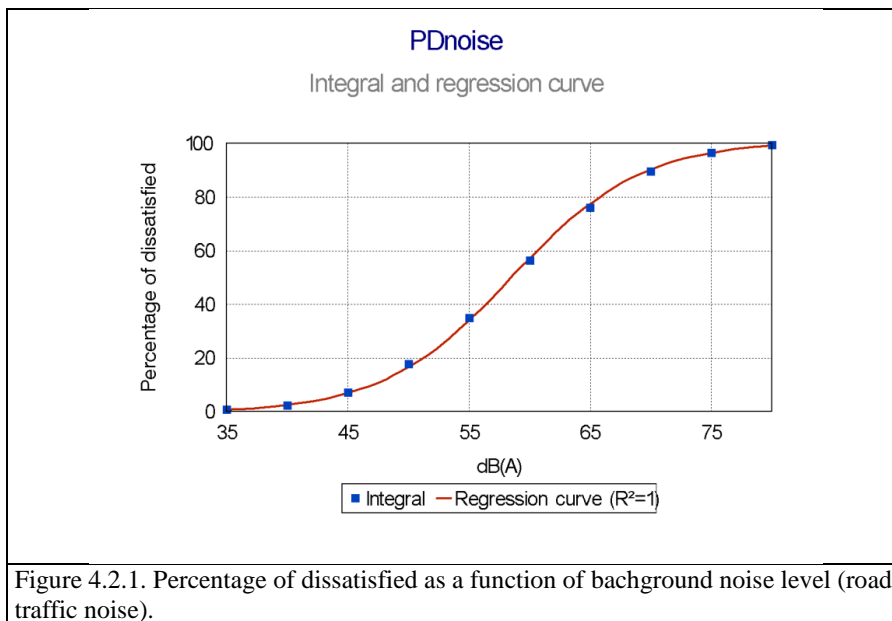

Figure 4.2.1. Percentage of dissatisfied as a function of background noise level (road traffic noise).

4.2.4 Cumulative noise level calculation method

In annex 1 of “Reken- en Meetvoorschrift Geluidhinder 2006” (170) a Dutch Governmental Noise regulation, a calculation method for cumulative noise levels is shown. In this calculation method the noise level from rail traffic (L_{RL}), industry (L_{IL}) and air traffic (L_{LL}) is converted into a noise level for road traffic which causes the same disturbance (L_{RL}^* , L_{IL}^* , L_{VL}^*). The reduction mentioned in article 110g of the regulation for road vehicle noise is not used in

this calculation procedure. All these values must be expressed as L_{den} , with the exception of industrial noise, whose noise level is determined according to the applicable legal definition. This calculation method can be used when there is exposure to more than one noise source.

Formulae:

- $L_{RL}^* = 0.95 * L_{RL} - 1.40$
- $L_{LL}^* = 0.98 * L_{LL} + 7.03$
- $L_{IL}^* = 1.00 * L_{IL} + 1.00$
- $L_{VL}^* = 1.00 * L_{VL} + 0.00$

If all applicable sources are converted to L^* values then the accumulated value can be calculated by means of the so called energy summation. The calculation form is:

$$L_{cum} = 10 \log \left[\sum_{n=1}^N 10^{\uparrow} (L_n^* / 10) \right]$$

Where all applicable sources N are accumulated and the index n can stand for RL, LL, IL and VL.

The accumulated value can eventually be converted to a noise level equivalent to one of the source noises.

4.2.5 Calculation results

Using the previously mentioned relationship of the percentage of dissatisfied as a function of the equivalent noise level and the calculation method, according to “Reken- en meetvoorschrift Geluidhinder” (170), it is possible to calculate for each noise source or combination of noise sources the percentage of dissatisfied as a function of the equivalent noise level. The calculation results are shown in the following graphical representation, figure 4.2.2.

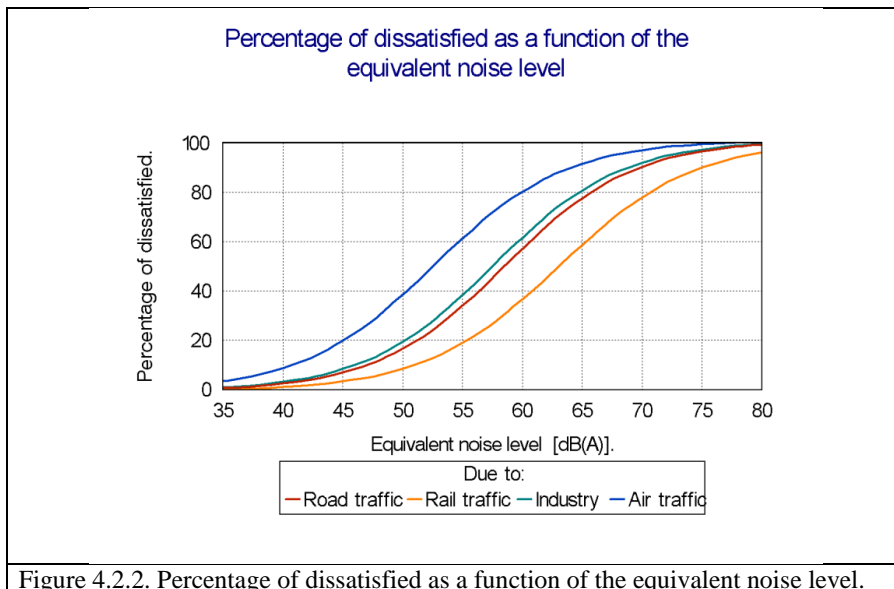

Figure 4.2.2. Percentage of dissatisfied as a function of the equivalent noise level.

Table 4.2.1 more accurately summarises the maximum noise level per source within a percentage of dissatisfied of 0 to 20%.

Table 4.2.1. Maximum equivalent noise level as a function of the percentage of dissatisfied.

Percentage of dissatisfied {PD _{noise} } [%]	L _{road} [dB(A)]	L _{rail} [dB(A)]	L _{industry} [dB(A)]	L _{air} [dB(A)]
0	31	34	30	25
5	43	47	42	37
10	47	51	46	41
15	49	53	48	43
20	51	55	50	45

Shaded: L_{Aeq} ≤ 45 dB(A).

A proposal for a classification of the environmental noise level within buildings coming from traffic and industry is shown in Table 4.2.2.

Table 4.2.2. Proposal for classification.

Category	PD _{noise} [%]	L _{cum} [dB(A)]	Back ground noise level per source sort without the other source sorts [dB(A)]			
			L _{road}	L _{rail}	L _{industry}	L _{air}
A	< 1	< 36	< 36	< 39	< 35	< 29
B	< 5	< 43	< 43	< 47	< 42	< 37
C	< 10	< 47	< 47	< 51	< 46	< 41

Figure 4.2.3 shows, graphically, for each noise source, the percentage of dissatisfied and the percentage of seriously disturbed (161) as a function of the equivalent noise level. Eventual differences between outside noise levels (Miedema curves) and inside (PD_{noise}) are ignored.

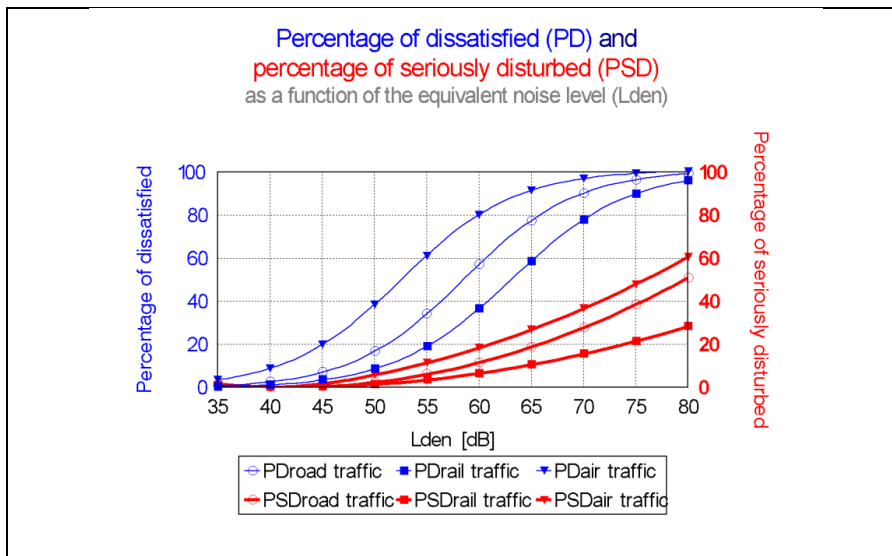

Figure 4.2.3. Percentage of dissatisfied and percentage of seriously disturbed as a function of the equivalent noise level.

N.B.: The thin (blue) curves relate to the left y-axis and the thicker (red) curves to the right y-axis.

4.2.6 Conclusion

- It makes sense to use the guideline CR-1752 and standard EN-15251 within the frame of, especially performance based, contracts and programs of requirements in the housing process.
- Using the percentage of dissatisfied for classification and as a evaluation criterion is understood by everyone
- Using the percentage of dissatisfied as the evaluation criterion, related to the equivalent background noise level, produces a more refined evaluation of comfort than an evaluation based upon the percentage of seriously disturbed or the effects of sleep deprivation in relation to the environmental noise (161)
- The method and proposal for classification is a useful addition to the European standard and guideline concerning classification of the indoor environment, based upon the percentage of dissatisfied, as referred to.

Noise levels to about 45 dB/dB(A)

From, in particular, Table 4.2.1, it appears that, with the exception of air traffic, the percentage of dissatisfied, at a noise level approaching 45 dB /dB(A) per source, remains below 10%. Rail traffic noise is even less than 5%.

Only air traffic noise causes the amount of dissatisfaction, dependent upon the noise level, to be relatively high.

Noise levels above ca. 45 dB(A)

Noise levels above 45 to 50 dB(A) causes the percentage of dissatisfied, due to all noise sources, to rise significantly.

4.2.7 Suggestions for further investigation

This chapter is a proposal and a first step to develop a method to evaluate and classify environmental noise, according to CR-1752 (22) and EN-15251 (168), (23) based upon the percentage of dissatisfied, related to the equivalent background noise level.

The following steps are suggested:

- further investigation into the reliability and applicability.
- additional improvements and an extension of sources like the noise from restaurants, cafes and bars.
- to implement the method and proposal for classification in the guideline CR-1752 and the standard EN-15251.

5 Age

5.1 Design criteria for the indoor environment as a function of age

ABSTRACT If the society has the opinion that older people should work longer and should take care for themselves than, in the built environment, and particularly in the housing process, we have to note that the elderly have different requirements on health than young people. In the law and regulations, as well as the standards and guidelines, for elderly, however, are not explicitly taken into account.

Build with more care for health offers the possibility to reduce the chance of disease(s) and (the feeling of) insecurity, to stimulate the physical and mental activity and to provide support in the daily work and life operations. It increases the possibility of self-care and informal care and increases the quality of professional care. Viewed from this perspective the right performance requirements on the well-being of elderly are evident and the standards and guidelines are to be adapted as a matter of urgency.

This chapter is a first translation into a guideline for the indoor environment (acoustics, light, air quality and the indoor thermal climate) as a function of age.

Keywords

Comfort, healthcare design, indoor environmental quality, mathematical modelling, performance.

5.1.1 Introduction

Currently, 33.5 percent of the potential population (20-64-years olds) in the Netherlands is 50-plus. In 2025, this is expected to be 36,0 percent. The percentage will then decrease again to 31.4 percent in 2040. The ratio of the population aged of over 65 years compared with the potential population is currently 26,8 percent and will change to 49.6 percent till 2040 to go then down again (171). In particular the number of over 65 compared to the potential population will increase significantly in the coming years. This ageing aspect plus related problems (particularly the care and the pensions) mean that politicians are of the opinion that people should work longer (potential population augmentation) and take care of themselves longer (reduction care) than is usual at this time. Some political parties are even of the opinion that the pensionable age in 2040, depending on the CPB figures (CPB: Netherlands Bureau for Economic Policy Analysis), should be raised to 70 years (172), (173).

If the society is of the opinion that older people should work longer and should take care for themselves then, in the built environment, and particularly in the housing process, we have to note that the elderly have different requirements of health than young people. This is caused by the decline in sensory, physiological, neural and cognitive systems, depending on age (174). In the law and regulations, as well as the standards and guidelines, the elderly, however, are not explicitly taken into account, with the result that in the current situation housing for the elderly is more likely to be a disability than a comfortable, inspirational or safe environment (175), (176), (177), (178), (179), (180), (181), (182), (183) in short, a healthy environment, in accordance with the definition of the WHO¹, (173).

Build with more care for health offers the possibility to reduce the chance of disease(s) and (the feeling of) insecurity, to stimulate the physical and mental activity and to provide support in the daily work and life operations. It increases the possibility of self-care and informal care and increases the quality of professional care (184). Viewed from this perspective right performance requirements on the well-being of elderly are evident (184), (174) and the standards and guidelines are to be adapted as a matter of urgency (174), (173).

A beginning of a positioning relative to the challenges of the built environment for this subject, with the emphasis on the building services is published in (173).

This literature study is a first translation into a guideline for the indoor environment (acoustics, light, air quality and the indoor thermal climate) as a function of age. The impact on non-vital people (i.e. suffering from dementia) is disregarded.

¹) The definition of health, according to the World Health Organisation (WHO) as contained in its constitution reads: "Health is a state of complete physical, mental and social well-being and not merely the absence of disease or infirmity."

5.1.2 Decline in aerobic capacity with age

The ability of older persons to function independently is dependent largely on the maintenance of sufficient aerobic capacity and strength to perform daily activities. Peak aerobic capacity (characterized by the maximal oxygen uptake of a person; VO_2 max or peak VO_2 [$\text{mL}/(\text{kg}\cdot\text{min})$]) is widely recognized to decline with age; 10% per decade in sedentary persons ≥ 25 years of age and 15% per decade between the ages of 50 and 75 years, on the basis of cross-sectional data (185). The longitudinal rate of decline in peak VO_2 in healthy adults is not constant across the age span in healthy persons, as assumed by cross-sectional studies, but accelerates markedly with each successive age decade, especially in men, regardless of physical activity habits (186). The accelerated rate of decline of peak aerobic capacity has substantial implications with regard to functional independence and quality of life, not only in healthy older persons, but particularly when disease-related deficits are superimposed (186). The rate of decline accelerated from 3% to 6% per 10 years in the 20s and 30s to 20% per 10 years in the 70s and beyond (186). The rate of decline for each decade is larger in men than in women from the 40s onward (186). From the 50s onward, longitudinal declines in peak VO_2 for men and women are substantially larger than cross-sectional declines (186).

5.1.3 Light

General

Well seeing depends on (187):

- Good eyes (particularly the accommodation capacity and the adaptation capacity)
- Brains
- Observing time
- Contrast
- Enough light
- Age.

The effects of old age for the eye are (187), (188):

- The decrease in pupil diameter, having the consequence that less light falls on the retina
- A thickening, yellowing and inflexibility of the lens
- The less transparency of the lens
- The milky white of the glassy body
- The decrease in the density of the photoreceptors
- A biochemical and anatomical degeneration of the retina
- Aqueous eyes.

As people age, the accommodation and the adaptation capacity of the eye reduce significantly. Research shows that, for example, the accommodation capacity of the eye, already after 55 years on average virtually reduce till nil, thus the amount of light that reaches the retina decreases and the stray light in the eye increases. In addition shows the spectral sensitivity of the eye to change with age. From previous enumeration it may prove that the general consequence for the elderly is a reduction in light sensitivity and color award as well as an increase in sensitivity to glare (174).

In the state-of-the-art (188) of the available knowledge and insights in the field of good and healthy lighting for seniors with attention to the knowledge gaps is in a conclusion summarized and is used in this chapter of this study. It presents a set of specifications to which a light concept in a home or living in a small scale community should meet elements, to provide op-

timal support, well-being and health of older people with the aim to stimulate a positive impact to remain independently for a longer period.

Relative light need

The relative light need, at the same view task, is depending on the age, namely (189):

- 10 years : 0.82
- 15 years : 0.89
- 25 years : 1.00
- 35 years : 1.29
- 45 years : 1.6
- 55 years : 2.26
- 65 years : 3.15
- 75 years : 4.99
- 85 years : 6.74
- 95 years : 8.20

Hence, for example, a 45-years-old needs roughly twice the illumination of a 10-years-old and a third of that of a 75-years-old. The recommendations in standards and guidelines apply to the non-ageing eye.

Desired light level for the elderly

The desired light level will change in time. The question is therefore whether for the elderly in general there is an optimum in light level. The visual performance at higher light levels increases, but the height of the desired light level is partly dependent on the aging of the eye and the presence of any eye diseases. The optimum light level follows personal preference and best performance. This calls for an adjustable lighting system that is tuned on the basis of personal preference and best performance and grows with the person. To be able to give an order of magnitude of the light levels, for the elderly from approximately 60 years, three to eight times the standard minimum visual light requirement (en. 1500 to 4000 lux for viewing task reading) can be held on. In addition possibly there should also be compensation for specific eye diseases. The light level in the various rooms is depending on the task in the space. The light level on the walking routes (100 lux, according to (190) for the non-ageing eye), for example, should be at a minimum of 300 lux at floor level but should be able to be increased to 800 lux, depending on the preference and needs of the users. For a kitchen and bathroom it can be held on the 1000 – 2500 lux respectively the counter top and the person (188).

Uniformity of the light distribution

In the environment of the elderly, the eye must be prevented from adapting constantly between high and low light levels, this causes fatigue and headache. A uniformity of at least 70% on the task level and 50% in the room is acceptable (188), (190)

Color reproduction

For a good color perception, the use of light sources with good color-reproduction (Ra-value > 85) is necessary. For visual viewing tasks, fluorescent light is preferred over filament lamps because of the higher blue component in the light as a compensation for yellowing of the eye lens. It is considered good in a living room to choose warm-white light (2700-3000 K) (188).

Brightnesses

Although for the older eye more light is needed in order to see, excessive brightnesses around older people must be avoided. This results in uncomfortable situations in which portions of the

subject will be veiled. Glass planes (Note: also on the north side of a building) must be equipped with an automatically controlled brightness resistance. Starting point at the permissible brightnesses is preventing exceeding of the relationship between task: direct face-field: environment. This relationship should be preferably 1: 3: 10 (188).

Interior trim

The window frames should be finished with a lightcolor to reduce contrast differences with the daylight. Curtains for the same reason, should be preferably in a light color. Walls, floor and walls should be preferably finished with a light color too. Door knobs, banisters, brackets, pathways, railings, etc. and other elements that serve for grabbing or support, serve to be executed in high contrast with the surroundings (188).

View

In a sitting position, one needs to have an exterior view. In high-rise buildings, it is important that one can see the street from a sitting position at the window. Of interest is that there is variation in the view and the elderly is encouraged, so that the elder does not quickly get bored and the high vertical luminous intensity on the eye provides the necessary biological incentive (188).

Daylight

Windows that reach the ceiling give a higher daylight contribution deeper in space, allowing a better distribution of daylight in the room.

Sun protection is preferably on the outside of the facade and protects against direct light in such a way that the color of the interior is not affected. Awnings are preferably in a light color to let enough light in the interior. Awnings in one color are preferred over striped ones. Striped awnings with contrast colors, such as white and dark blue, are more tiresome for the eye than awnings in white and yellow. Brightness resistance control consists preferably of horizontal blinds, because they can be set in such a way that the view outside is preserved (188).

5.1.4 Thermal indoor climate

General

According to experiments of Fanger (84) the thermal comfort of a person is not dependent on gender, race, country of origin or age.

Age

Outside the comfort area, on the other hand, age does affect the thermal sensation and the performance of the elderly. The latent heat loss of the elderly is shown, for example, to be less than that of young people, also notes Fanger (84) in his dissertation. This combined with a difference in clothing behavior/-adaptation (191) explains why the body of the elderly cools less, especially in the warm part outside the comfort area.

It has been observed that the metabolism of the elderly is lower than that of young people (84). This might be one of the reasons too for the difference in the desired indoor temperature in practice in relation to young people.

Vitality

Garssen et al. (178) examined mortality in the Netherlands during the heat wave in 2003. They concluded that the extra mortality in this summer was between 1400 and 2200 dead. They found this additional mortality, as well as other researchers, at the highest age groups (65 years). But also for the age group 40-59 years was death in August 2003 11% higher than

normal. In younger age groups mortality did not increase.

Medications

Little is known about the exact influence of medications (eg. Beta-blockers, high blood pressure, etc.) and/or alcohol use on the thermoregulation system of man.

General thermal comfort

Hwang and Chen (191) investigated the behavior, the adaptation and thermal comfort of elderly people in residential environments. The research results are also compared with a similar study carried out previously, by Chen and Hwang, with young people. In this research one has derived two curves for the predicted percentage of dissatisfied (PPD) as a function of the mean thermal sensation vote (MTSV); one for the elderly and one for young people. The research results are displayed graphically in figure 5.1.1.

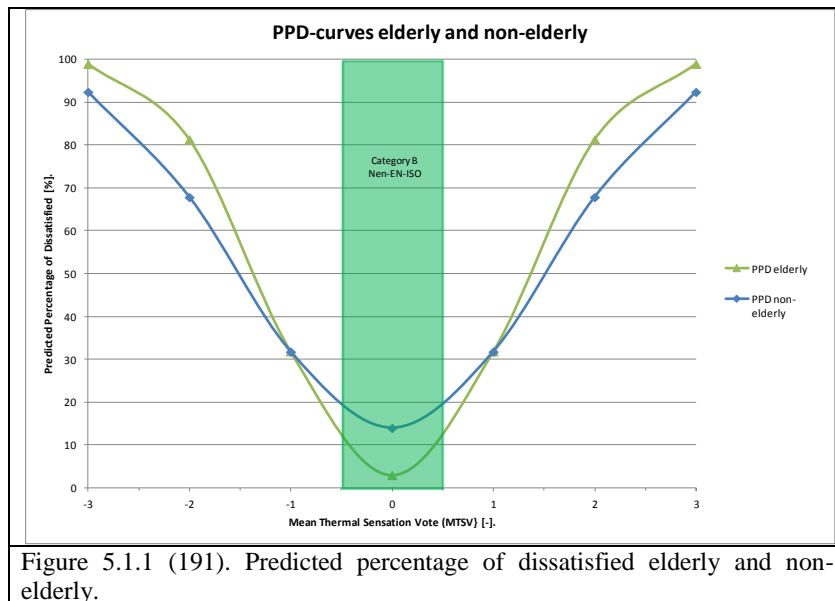

Figure 5.1.1 (191). Predicted percentage of dissatisfied elderly and non-elderly.

The neutral temperature for the elderly was in this research 25.2 ° C and 23.2 ° C, respectively, for the summer and winter situation. The area with 80% thermal acceptance in summer ranged for elderly between 23.2 and 27.1 ° C operative temperature relative to 23.0 and 28.6 ° C operative temperature for young people. The area with 80% thermal acceptance in the winter situation ranged for elderly between 20.5 and 25.9 ° C operative temperature. The research results show that older and younger people, even in the same environment, respond differently to the thermal indoor climate.

Also, the research results of Hwang and Chen show that in the case of elderly, outside the area, where we still reasonably speak about comfort (i.e. $|MTSV| \leq 0.8$), there is more dissatisfied about temperature underruns and temperature overruns than in the case of young people. Research by Roelofsen (96) and a later research by Roelofsen and 't Hooft (97) demonstrated for the office situation already that, if performance is included in the evaluation, it doesn't make sense to design climate installations on the basis of temperature underruns and temperature overruns. The research results of Hwang and Chen reflect that it makes sense not to do also in the living arrangements of the elderly, especially with professional care. The literature also

indicates that mild cold exposure (20°C at 0.04 clo) already can lead to increased systolic blood pressure in the elderly (180). Therefore, it is wise to protect the elderly against thermal fluctuations, even though they are minor (192).

Partial thermal discomfort - Draught

Draught is defined as an unwanted local cooling of the human body caused by air movements. Research of Griefahn et al. (193) indicates to what extent the metabolism and the external mechanical power affects draught. According to Fanger the basal metabolism of elderly is below that of 20-year-olds (average 4,7 W/m²). The draught model by Griefahn et al. (193) is based on the draught model, according to NEN-EN-ISO 7730, and has, in terms of parameters, a wider range of application than the draught model, according to NEN-EN-ISO 7730. This last model is derived by research on young adults (20-24 years of age) and is not validated to elderly (194).

The percentage of dissatisfied caused by draught, according to the research of Griefahn et al. (193), validated to people of 18 to 51 years of age, is calculated with the following function:

$$PD = (t_{sk} - t_a) \cdot (v_a - 0.05)^{0.623} \cdot (3.143 + 0.37 \cdot v_a \cdot Tu) \cdot (1 - 0.0061 \cdot (M - W - 70))$$

Herein is:

- PD = the percentage of dissatisfied caused by draught [%]
- $t_{sk} = 32.3 + 0.079 \cdot t_a - 0.019 \cdot (M - W)$ [°C]
- t_a = the air temperature [°C]
- v_a = the mean air velocity [m/s]
- Tu = the turbulence intensity [%]
- M = metabolism [W/m²]
- W = the external mechanical power [W/m²].

Owing to the wider range of application of this draught model, with regard of the draught model in (NEN)-EN-ISO-7730, it would seem advisable to use the draught model of Griefahn et al. (2002) in future to evaluate the interior concepts on the aspect of draught (195). The model does, however, need to be modified to include the effects of thermal sensation and the direction of the air stream, so that it becomes applicable to a thermally cool environment (PMV < 0) and different air streams, as displayed in the appendix (appendix 13.2).

Elderly and draught

The elderly are thought to be more sensitive to draught. However Griefahn et al. (196) found no systematic alterations with age. The only reasonable explanation for the discrepancy between the common experience in the field and the results in the laboratory (179 participants between 18-68 years) is that the elderly in usual situations are physically less active and thereby, due to a lower metabolic heat production, more sensitive to convective heat loss (196).

Fatigue

According to a common belief that fatigue after a bad sleep determines the response to draught and cold, Fanger's workgroup advised their participants to have a goodnight's sleep before the experimental sessions (197), (194). Indeed, an increased sensitivity, associated with fatigue was significantly more often related to a rather cool sensation, a preference for a higher temperature and draught-induced discomfort in the research of Griefahn et al. (196).

5.1.5 Individual differences

Recent research at the Technical University of Eindhoven shows that elderly (67-73 years), at varying temperature, have on average colder extremities than young adults (22-25 years). At the same room temperature their fingertips in that group are on average 2.6 °C colder than the fingertips of young adults. In the design of climate systems one should for that reason give more consideration to the individual differences (e.g. heating in table tops connected to presence detection) (198), (199). A lower skin temperature for women as compared to men was found too at a research of Hashiguchi et al. (200) on the influence of vertical temperature gradients on the thermal comfort and the cognitive performance of men and women.

5.1.6 Air quality

Research shows that the carbon dioxide (CO₂) content in indoor air is a suitable indicator of the air pollution caused by man (142), (135). Several studies pay attention to the changed insights on the criterion for CO₂ concentration in the indoor air (201). For healthy adults (20 – 55 years) one would like a limit value of 800 ppm (parts per million) to persist, for the elderly (> 55 years) and children 700 ppm and for the group with ailment and intolerance 600 ppm. A CO₂ concentration from 600 to 700 ppm can cause irritation to the eyes and the respiratory tracts. The Dutch Building Act (2003), however, is based on 1200 ppm (202); which is in marked contrast with the aforementioned insights.

Taking into account the above limit values, according to (201), in accordance with the method described in Roelofsen (142), the following minimum required air volume per person can be calculated, as shown in Table 5.1.1 (shaded cells).

Table 5.1.1. Required fresh air quantity (seated activity, ideal mixing).

CO ₂ -limit value ²⁾ [ppm]	Young people [m ³ /h/pp]	The elderly [m ³ /h/pp]
1200	22.5	21.0
800	44.4	41.4
700	58.7	54.8
600	86.7	80.9

²⁾ Carbon dioxide level outdoors = 390 ppm.

5.1.7 Noise

General

According to a literature study of Parsons (174) the decrease in hearing sensitivity is the result of noise exposure, disease, trauma and age. With increasing age of the elderly:

- higher sound levels are needed, especially in the high frequencies from 1000 Hz, in order to recognize sound
- background noise and unwanted signals are more difficult to filter
- difficulty arises with varying changes in sound
- an intolerance arises for irritating sound
- more hearing abnormalities arise (e.g. Tinnitus).

Environmental noise

Analyses of Van Gerven et. al. (203) consistently show that annoyance from noise follows an inverted U-shaped pattern as a function of age, where the youngest and oldest respondents report the lowest, and people in their mid-40s report the highest levels of annoyance (see figure 5.1.2).

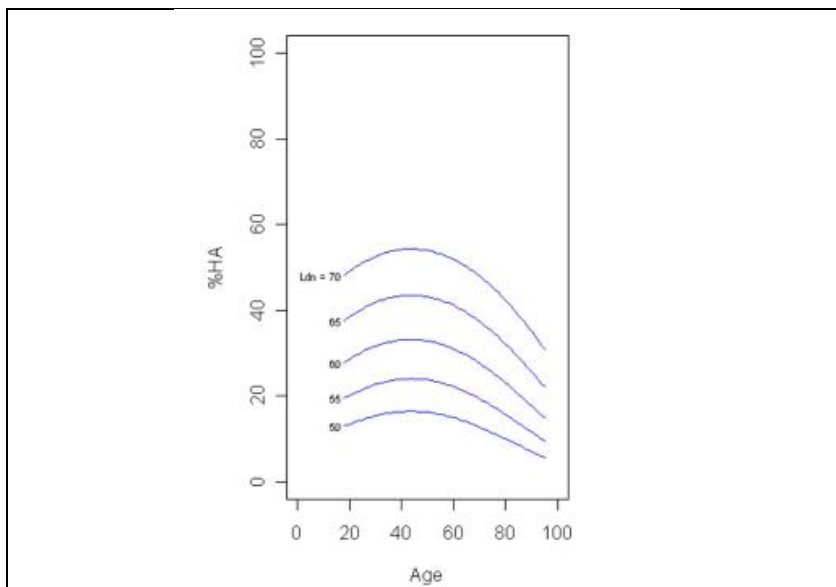

Figure 5.1.2. Predicted percentage of highly annoyed persons (%HA) as a function of age and noise level (Ldn in dB(A)). Ldn is defined in terms of L_{Aeq} (average equivalent noise level) during daytime and nighttime, and applies a 10 dB(A) penalty to noise in the night (203).

For example, among 45-year-olds, their model predicts up to 10% more highly annoyed individuals than among 20-year-olds, and up to 20% more highly annoyed individuals than among 80-year-olds. This pattern of results was found in a very large, pooled international dataset as well as in a separate large aircraft noise dataset (Amsterdam Airport Schiphol; 62,983 individuals aged between 15 and 102 years). The latter appears to have been affected by the social unrest that was evoked by plans to expand Amsterdam Airport Schiphol. However, this was only the case for the model coefficients, not for the nature of the effect of age on annoyance (e.g., the age at which annoyance peaks). The samples analysed in their study are highly representative, not only because of their size, but also because they include individuals from culturally and socially diverse countries, including two non-Western countries, Turkey and Japan. This adds to the potential importance of the current results.

Speech intelligibility

In 1980 Houtgast, Steeneken and Plomp have developed a method to assess the speech intelligibility in rooms, on the basis of the Speech Transmission Index (STI) (204).

The STI is a measurable and computable quantity of speech intelligibility whose value varies between 0 (not intelligible) and 1 (excellent intelligible). Voice is modulated by a test signal with certain speech characteristics; based on the concept that speech can be described by a broadband white noise modulated with certain fluctuation frequencies. At the place of receipt is the modulation depth of the received signal in a number of frequency bands compared to that of the test signal. The speech intelligibility loss is related to the reduction in the modulation depth.

The relationship between the speech transmission index and the speech intelligibility is explained in more detail in Table 5.1.2.

Table 5.1.2. Translation speech transmission index to intelligibility qualifications (154).

Speech transmission index [-]	Speech intelligibility
0.00 – 0.30	Bad
0.30 – 0.45	Poor
0.45 – 0.60	Fair
0.60 – 0.75	Good
0.75 – 1.00	Excellent

Correction by age

The STI-method does not take into account the decline in hearing of the elderly. It is for that reason that Plomp and Mimpen figured out a correction method (205), with which the age of the elderly is considered in the evaluation of the speech intelligibility in a space and which is connected to the STI-method.

Plomp and Mimpen (205) utilize the parameter “Speech Hearing Loss in noise” as a function of the age group (SHL_D), as shown in Table 5.1.3.

Table 5.1.3. “Speech Hearing Loss in noise” as a function of the age group.

	SHL _D in dB per age group							
	20-29	30-39	40-49	50-59	60-69	70-79	80-89	90-96
Men	0.0	0.2	0.8	1.2	2.5	4.2	7.0	-
Women	-	-	-	-	3.0	3.3	5.6	10.7

With a transition in STI-differences, on the basis of the above parameter it is possible to consider hearing loss in the evaluation of the speech intelligibility for the elderly. Every 3 dB of SHL_D in Table 5.1.3 means an increase of 0.1 in STI. For correct understanding of 50% of sentences in noise, subjects aged between 80 and 90 for example need a STI of 0.2 to 0.3 higher than young subjects. This may demonstrate that taking more care of the acoustics of rooms frequented by elderly people is highly recommendable (206).

The link between the average percentage of men and women with hearing loss exceeding for speech in noise as a function of age is displayed graphically in figure 5.1.3. For example, suppose that in an auditorium the speaker cannot be understood by those subjects with a SHDL_D of more than 5 dB. Figure 5.1.3 shows that, at the age of 75, 35% of the population will belong to that category (206).

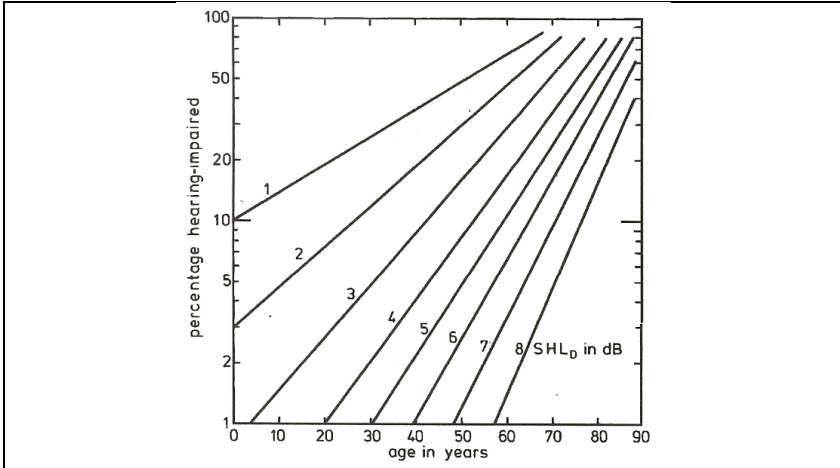

Figure 5.1.3. The average percentage of men and women with hearing loss exceeding for speech in noise as a function of age (206).

In Figure 5.1.4 is displayed graphically the speech intelligibility for different age groups, as a function of the average reverberation time in a situation of a meeting room (Volume: 143 m³) in which someone talk with an average raised voice (60.7 dB (A)).

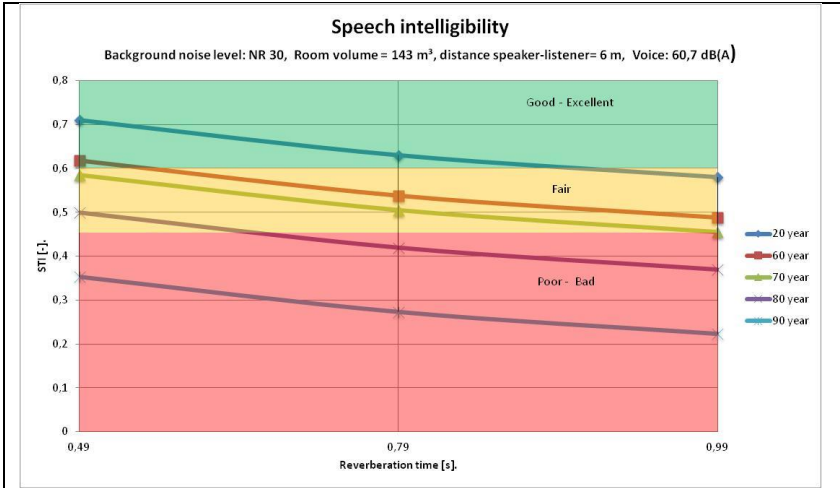

Figure 5.1.4. Speech intelligibility for different age groups as a function of the mean reverberation time (this study).

On the basis of the calculation results in figure 5.1.4, it is plain to see that what for a younger person, 20-29 years old, is to understand good to excellent, for the elderly, at higher average reverberation times, is soon no longer good. At a higher background noise level this effect is increased.

5.1.8 Build for health and performance enhancement

After the above, it is obvious that older people have a lower tolerance for uncomfortable situations than young people. The built environment strongly affects the working, learning, health,

care and healing process, the support of older people and the reducing of errors, accidents, inconvenience and the (feeling of) insecurity. The built environment with smart technology, is to arrange things in such a way that people are inspired, become more active, learn better and are less likely to get sick and be uncertain and heal faster, receive faster aid, are less likely to fall victim to accidents and are better facilitated in their activities (183).

The largest cost for healthcare institutions are salaries and costs for delivering care. Investments in buildings are only a small part of the total cost. Investments in a healthy built environment brings several benefits.

Light

The Netherlands Institute for Neuroscience (NIN) shows that good lighting in nursing homes is not just important for the residents, but also facilitates care. Extra light inhibits depression among residents and stimulates the memory function and the orientation ability. Another positive effect of good light during the day is reduction of nightly unrest at (demented) elderly (207), (208), (209). Varadarajan (210) shows in his research that the lighting level affects the number of errors that the nursing staff makes when preparing and handing out medications in a nursing facility.

Noise

A study by Harris and Reitz (211) shows that the speech intelligibility in the elderly, stronger than in young people, is influenced by the background sound level and reverberation time in a room. This effect is of negative affect on the participation of older people in the social life and the community life.

Scientific research shows that less noise lowers the blood pressure of patients in health care institutions, their sleep improves and reduces costly reuptakes. It also turns out that noise reduction helps reduce perceived pain and intake of pain medication, and can help to reduce the risk of burnout among employees (212).

Cognitive performance and profitability

Several scientific studies show that the indoor environment affects alertness and cognitive performance of people (213), (145), (57), (214), (215).

Learning performance can be distinguished from office work performance. Learning performance is considered to be efficiency to acquire knowledge, but office work performance is more likely to be efficiency to utilize the acquired knowledge. Intervention field experiments by Goto and Ito (216) were conducted on late-teen subjects (16-22 years) according to a procedure with a video lecture and examination. The examination score was found to be improved when PMV was close to zero, or outdoor air supply rate was increased. Based on the comparisons with previous studies, it was considered that the learning performance of young people (16-22 years) is more affected by the indoor temperature and outdoor air supply rate than that of older people (late-20 to 40 years).

Profitability calculations show that an investment in improving thermal indoor climate in an office situation has recouped within one to two years if the performance improvement of the employees is taken into account in the consideration (96), (97).

Green

Maas has assessed in her thesis (217) that there is a strong relationship between greenery and health. This is particularly the case with children, elderly and people belonging to a lower socio-economic status. With this aspect it is obvious to think of a greater expansion of greenery in the society in combination with smart technology to re-vitalize the elderly (e.g. vitality parks and gardens – e.g. the TimePoint-system at the Maxispark in Leidsche Rijn in the

Netherlands).

A study conducted by KPMG, commissioned by the Ministry of Economical Affairs, Agriculture and Innovation, shows that more greenery reduces the number of patients, for seven diseases, and saves on the cost of care and absenteeism. The payback period is expected to be between five and twelve years (218).

5.1.9 Conclusion

To increase well-being for people with different ages the design criteria for the indoor environment should be changed because research show that:

- older and younger people, even in the same environment, respond differently to the indoor environment
- older people have a lower tolerance for uncomfortable situations than young people.

To which extent a built environment, according to, for example, the healing environment principle, is of influence on the health and the performance of older people and health care professionals is not yet to answer. For that more research is needed than is considered within the framework of this study.

However build with care for health offers the possibility to:

- reduce the chance of disease and (the feeling of) insecurity,
- stimulate physical and mental activity,
- offer support in the daily work and life operations.

It increases the possibility of self-care and informal care and increases the quality of professional care (184). Viewed from this perspective the right performance requirements on the well-being for elderly are evident (184), (174) and the models, standards and guidelines are to be adapted as a matter of urgency, as the current evaluation models and criteria are often based on research at young adults in particular (174)

The performance requirements of the indoor environment aspects are not or insufficiently being studied for their effect on quality of life, care and health (184). This is research that needs to be performed. The conducted surveys up to now show, however, already that an unhealthy environment burdens staff in charge and has a negative impact on the functioning and recovery of elderly and patients. Improving the built environment, makes it a remarkable cost-efficient way to support the performance of employees, the recovery of patients and the operation of elderly. These characteristics serve to be of influence on the design and operation of care and treatment institutions. The relationship between the physical environment and the aforementioned characteristics offers the possibility to design on performance improvement resulting in a green and healthy environment for the users and a consistent financial benefit to the organization.

5.2 The influence of age on thermal sensation and dissatisfied

ABSTRACT. The key question in this study is: "Is the influence of age on thermal sensation and dissatisfied mathematically to describe?". This study proves that it is possible to mathematically describe the influence of age, by means of a comparison between the calculation results of a thermophysiological two-node model, adjusted for individual characteristics, and different experimental studies.

Since the various subgroups of elderly are increasing in number disproportionately to other age groups, adapting the existing thermophysiological human models, for predicting the thermal response of people depending on age and sex, is important. In this way, useful insights can be realized from modelling the thermal behavior and response patterns of the elderly for the future design of buildings and climate installations.

Keywords

Thermal comfort, mathematical modelling, individual characteristics, thermal sensation, predicted percentage of dissatisfied, elderly, non-elderly.

5.2.1 Introduction

To increase wellbeing of people with different ages the design criteria for the indoor climate should be adapted (219), because it appears that:

- Elderly people and non-elderly, in the same environment, experience the indoor climate differently
- Elderly people have a lower tolerance for uncomfortable situations than non-elderly.

Since the various subgroups of elderly are increasing in number disproportionately to other age groups, adapting the existing thermophysiological human models, for predicting the thermal response of people depending on age and sex, is important. In this way, useful insights can be realized from modelling the thermal behavior and response patterns of the elderly for the future design of buildings and climate installations (220).

In this study it is investigated to which extent the influence of age on thermal sensation and dissatisfied is mathematically to describe.

By means of a comparison between different experimental studies and a thermophysiological two node model, adjusted for individual characteristics, it is proved that it is possible to mathematically describe the influence of age on thermal sensation and dissatisfied.

5.2.2 Functional changes with age

With age functional changes occur in the body which impacts on the thermoregulatory system of the human body. The result is the alteration of the older individual's response to variations in the ambient temperature in contrast with the non-elderly. Reduced cardiac output, reduced muscle mass, reduced temperature sensitivity, atrophy of the skin, an increase in body fat and reduction in basal metabolic rate, are some of the effects of ageing. There is a gradual age-related loss of neural tissue up to 46% in humans over the age of 50 years. From the age of 20 to 60 years, neural losses are only around 0.1% per year but the process speeds up thereafter with reported cerebral blood flow decreasing by 20%. The progressive loss of neurons and the associated reduction in impulse velocity and changes within the spinal cord typically leads to a slowing of reaction times. This can create problems for an older person encountering painful or harmful stimuli. Neurotransmitters in the body also suffer from age-related decline in their synthesis and receptors. The peripheral nerve cells often show a progressive degeneration with age which results in the slowing of the conduction of nerve impulses by around 5 to 10%. These depletions of the neurotransmitters and alterations in nerve density, electrophysiological and neurochemical properties of the afferent pathway to the brain significantly alter structures and functions of the nervous system. Indeed, all these changes affect how an older person's body responds to the thermal challenge of either hot or cold stress (221). Some of the risk factors of an older person's response to heat include, increased threshold of sweating with a diminished sweating response which has the likelihood of inducing heat accumulation in the older person's body. Other risk factors include reduced vasodilation (the widening of blood vessels) and ability to adapt. These conditions are likely to expose the older person to thermal injuries including hyperthermia (elevated body temperature due to failed thermoregulation) and heat stroke (hyperthermia with a body temperature greater than 40,6°C). In response to cold exposure, the risk factors of ageing include delayed onset of shivering, which has a high likelihood of causing drastic fall in the older person's core body temperature. Other risk factors include diminished shivering response and vasoconstrictions (the narrowing of blood vessels) which may expose older persons to thermal cooling including moderate to severe hypothermia (a body core temperature below 35°C) (220).

5.2.3 *Methods and Results*

Fanger Model

The Fanger model (84), as described in NEN-EN-ISO-7730 (56), is based on experiments with young subjects. By far the greatest number of comfort studies have been carried out with young people as subjects, and consequently the existing knowledge on the influence of age on the comfort conditions is slight. In order to investigate this aspect, Fanger conducted an experiment, by with 128 elderly Danish persons (age $68,0 \pm 4,7$ years), who were exposed to exactly the same environmental conditions as the 128 Danish students (age $23,1 \pm 2,2$ years). The large age difference (45 years) between the two groups was primarily chosen to investigate whether a significant age-conditioned difference exists at all. As half of the subjects were females and half males, it was possible to study the influence of the sex on the comfort conditions also. The experiments showed no difference in comfort conditions between elderly and college-age persons, and it seems reasonable, therefore, to assume that the comfort equation applies to all adults. The results of the experiment showed however that the insensible perspiration for the elderly is lower than that for the college-age group. The decrease found in the evaporative heat loss for the elderly is about the same as the decrease in metabolic rate. These offset each other in the heat balance, and offer a reasonable explanation why no difference was found in the preferred temperature between the two age-groups. The reason for decreased insensible perspiration for the elderly could be that a change in the vapor diffusion resistance of the skin occurs as a consequence of age. Furthermore it should be remarked that behavior, at least for very elderly persons, tend toward quiet activity, and should be taken into account in the design of environments for older people (84).

Hwang and Chen (191)

Hwang and Chen (191) investigated the behavior, the adaptation and thermal comfort of elderly people (Age 71 ± 7 years) in residential environments. The research results are also compared with a similar study carried out previously, by Chen and Hwang, with young people (Age 34 ± 10 years). In this research two curves were derived for the Predicted Percentage of Dissatisfied (PPD) as a function of the mean thermal sensation vote (MTSV); one for the elderly and one for younger people. The research results are displayed graphically in figure 5.2.1.

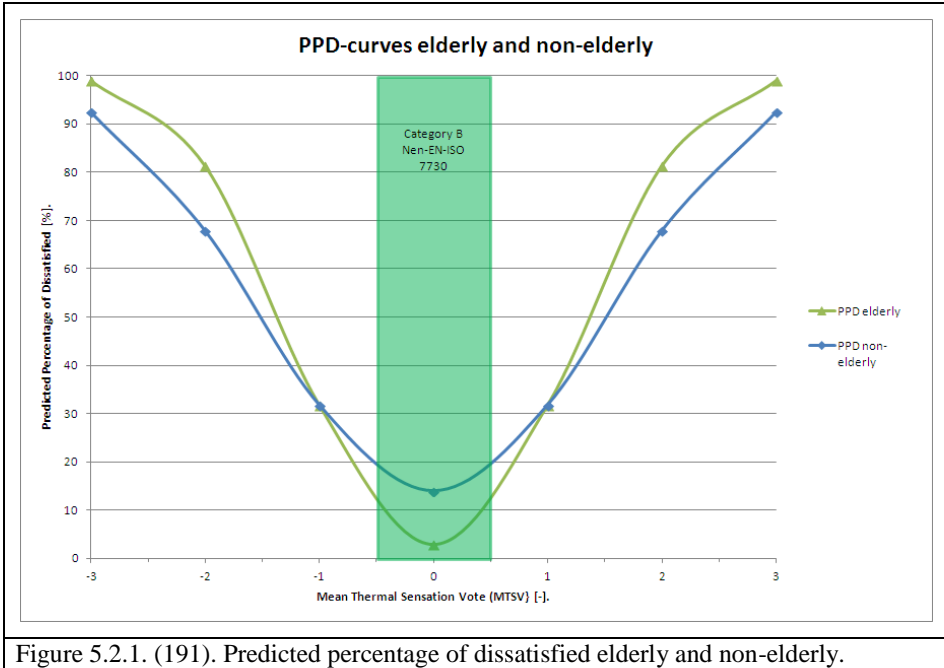

Figure 5.2.1. (191). Predicted percentage of dissatisfied elderly and non-elderly.

The equations for the overall Predicted Percentage of Dissatisfied (PPD), developed by Hwang and Cheng, are:

Non-elderly

- $PPD = 100 - 86 \cdot \exp(-0,2272 \cdot MTSV^2 - 0,0479 \cdot MTSV^4)$

Elderly

- $PPD = 100 - 97 \cdot \exp(-0,3338 \cdot MTSV^2 - 0,01972 \cdot MTSV^4)$

Herein is:

- MTSV = Mean Thermal Sensation Vote [-].

The neutral temperature for the elderly was in this research 25.2 °C and 23.2 °C respectively for the summer and winter situation. The area with 80% thermal acceptance in summer ranged for the elderly between 23.2 and 27.1 °C operative temperature relative to 23.0 °C and 28.6 °C operative temperature for young people. The area with 80% thermal acceptance in the winter situation ranged for the elderly between 20.5 °C and 25.9 °C operative temperature. In this study data from non-elderly in the winter situation are not published. The research results show that older and younger people, even in the same environment, respond differently to the thermal indoor climate.

Also, the research results of Hwang and Chen show that in the case of the elderly, outside the area, where we can still reasonably speak about comfort (i.e. $|MTSV| \leq 0.8$), there is more dissatisfaction about temperature underruns and temperature overruns than in the case of young people. Research by Roelofsen (96) and a later research by Roelofsen and 't Hooft (97) demonstrated for the office situation already that if performance is included in the evaluation, it does not make sense to design climate installations on the basis of temperature underruns

and temperature overruns. The research results of Hwang and Chen reflect that it makes sense not to do so also in the living arrangements of the elderly, especially with professional care. The literature also indicates that mild cold exposure (20°C at 0.04 clo) already can lead to increased systolic blood pressure in the elderly (180). Therefore, it is wise to protect the elderly against thermal fluctuations, even though they are minor (192).

Schellen et al. (199)

Schellen et al. studied the effects of a moderate temperature drift on physiological responses, thermal comfort, and productivity of eight young adults (age 22–25 years) and eight older subjects (age 67–73 years). They were exposed to two different conditions: a control condition; constant temperature of 21.5°C; duration: 8 h (S1 session); and a transient condition (S2 session); temperature range: 17–25°C, duration: 8 h, temperature drift: first 4 h: +2 K/h, last 4 h: –2 K/h. The results indicate that thermal sensation of the elderly was, in general, 0.5 scale units lower in comparison with their younger counterparts. Furthermore, the elderly showed more distal vasoconstriction during both conditions. Nevertheless, thermal sensation of the elderly was related to air temperature only, while thermal sensation of the younger adults was also related to skin temperature. During the constant temperature session, the elderly preferred a higher temperature in comparison with the young adults. A temperature drift up to ± 2 K/h in the range of 17–25 °C is assessed as applicable and did not lead to unacceptable conditions. Although the Fanger model is developed for steady state conditions Schellen et al. (199), in accordance with other researchers [cited in Schellen et al. (199)], conclude that the Predicted Mean Vote (PMV) might also be applicable for transient conditions.

Individualized model of human thermoregulation

In order to calculate the thermal differences between the elderly and non elderly a computer program, in first instance assembled for the calculation of the performance loss as a function of thermal discomfort or heat stress (222); see chapter 2.1 in this thesis), on the basis of the two-node Gagge model (55), is adjusted with individual characteristics, according to a study of Havenith (223).

These individual characteristics, besides the personal parameters that are already incorporated in the Gagge model (i.e. metabolic rate, mechanical efficiency, length, weight, skin fold, and clothing resistance), are:

- Gender
- Age
- Percentage of body fat
- Fitness (i.e. VO_{2max})
- Number of acclimated days.

The adjusted two-node model is used to simulate the S1 and S2 session of the research of Schellen et al. (199). Some of the calculation results, as well as the measured results of the research of Schellen et al., are displayed in the figures 5.2.2 to 5.2.4.

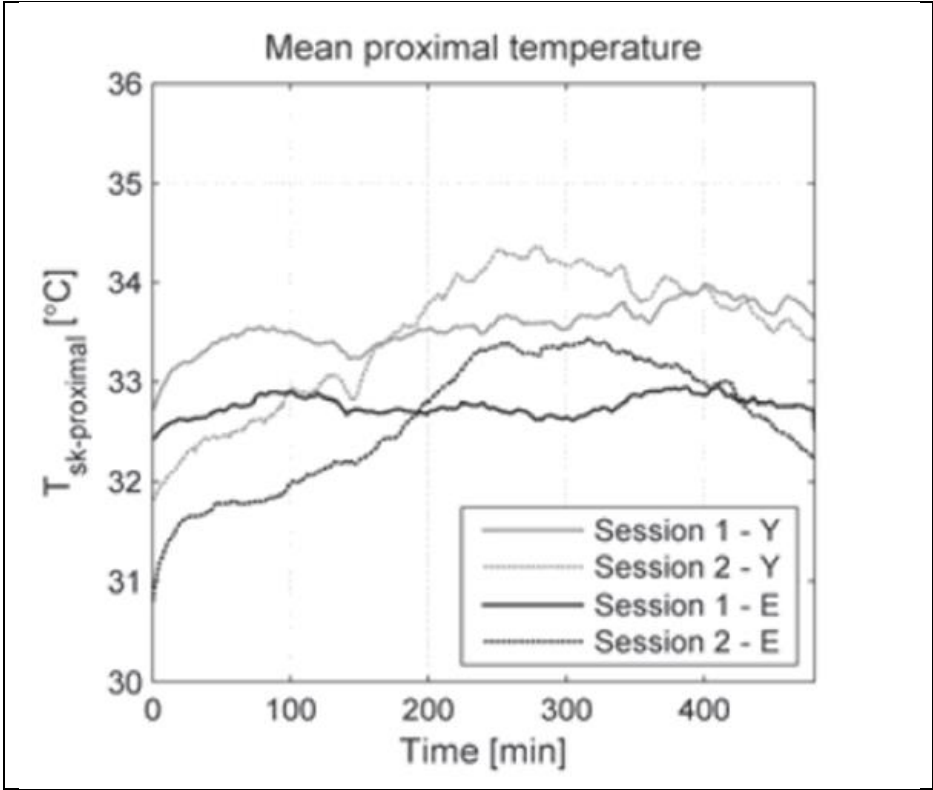

Figure 5.2.2a. Measured skin proximal temperature S1 and S2 session Schellen et al. (199). Y=Non elderly, E=Elderly.

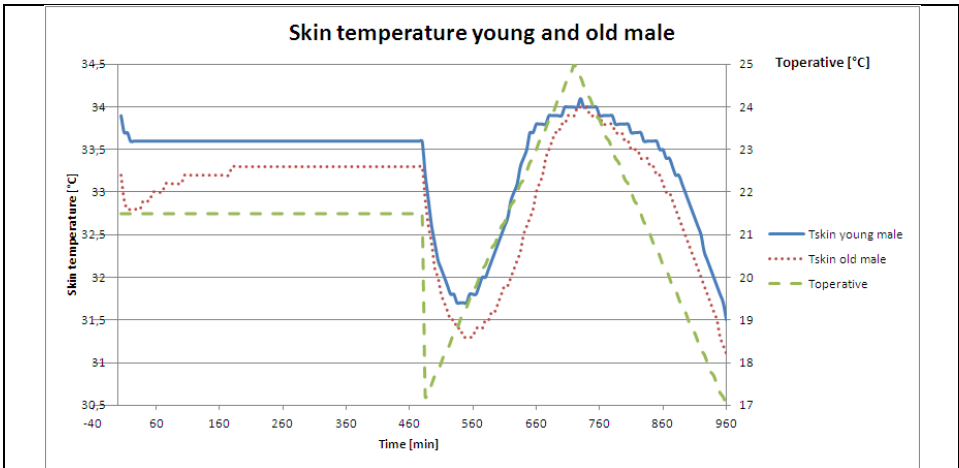

Figure 5.2.2b. Calculated skin temperature with the adjusted two-node model (this study).

Without the adjustment of specific control parameters (e.g. sweat control), the model appears to overestimate the maximum skin temperature for the elderly (figure 5.2.2a and 5.2.2b).

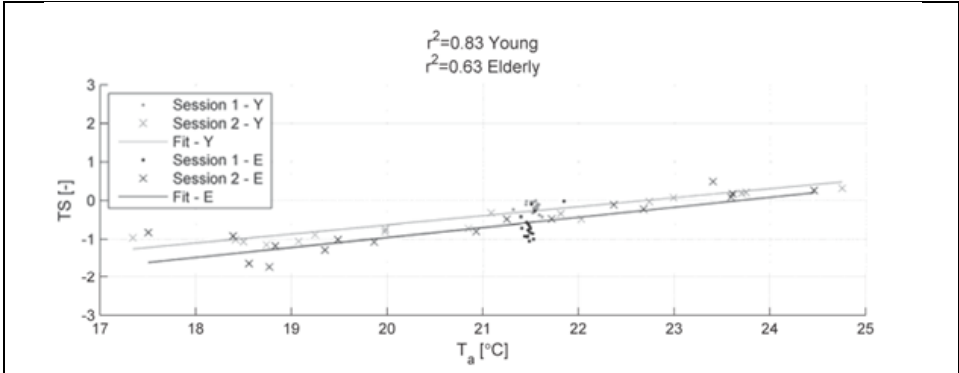

Figure 5.2.3a. Linear regression analysis S1 and S2 session Schellen et al. (199).

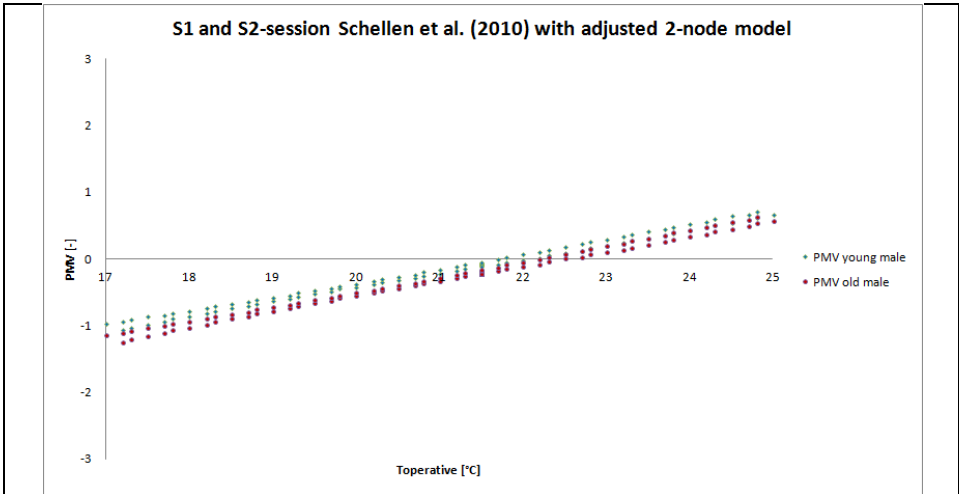

Figure 5.2.3b. Linear regression analysis calculated PMV for S1 and S2 session with the adjusted two-node model (this study).

The results of the experiments of Schellen et al. (199) (see figure 5.2.3a), indicate that thermal sensation of the elderly was 0.5 scale units lower in comparison with their younger counterparts. In the case of the adjusted two-node model the difference is around 0.3 scale unit lower (figure 5.2.3b).

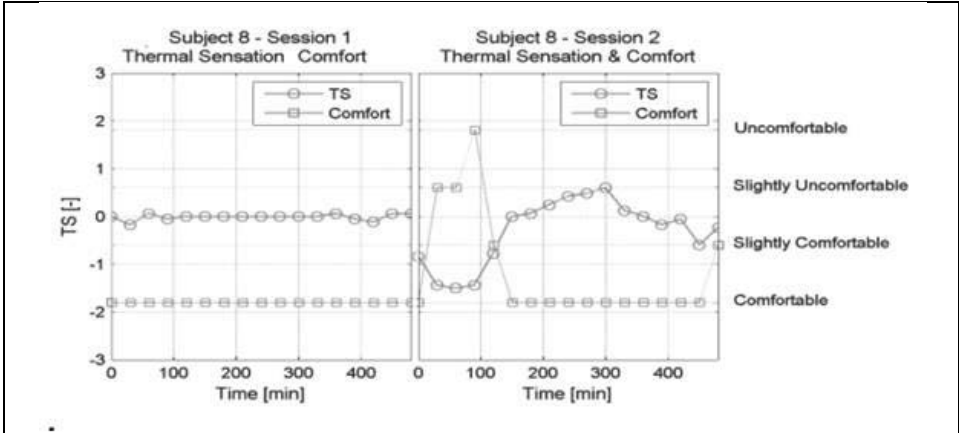

Figure 5.2.4 a. Thermal sensation young individual Schellen et al. (199).

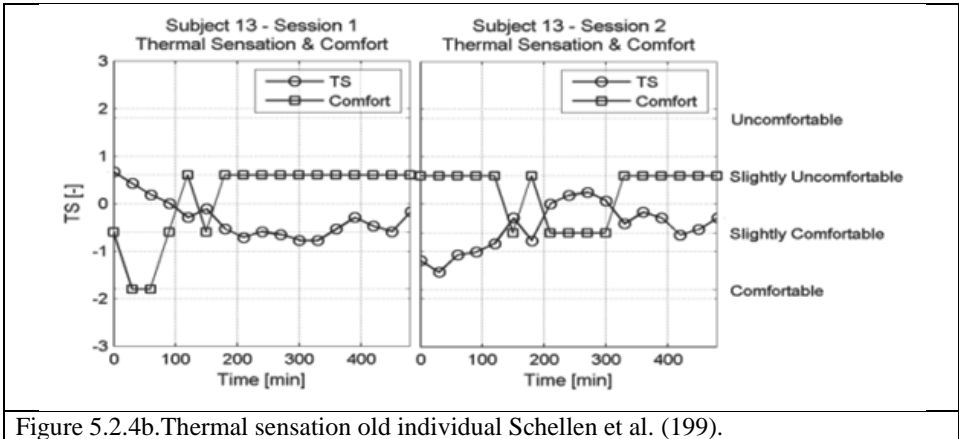

Figure 5.2.4b. Thermal sensation old individual Schellen et al. (199).

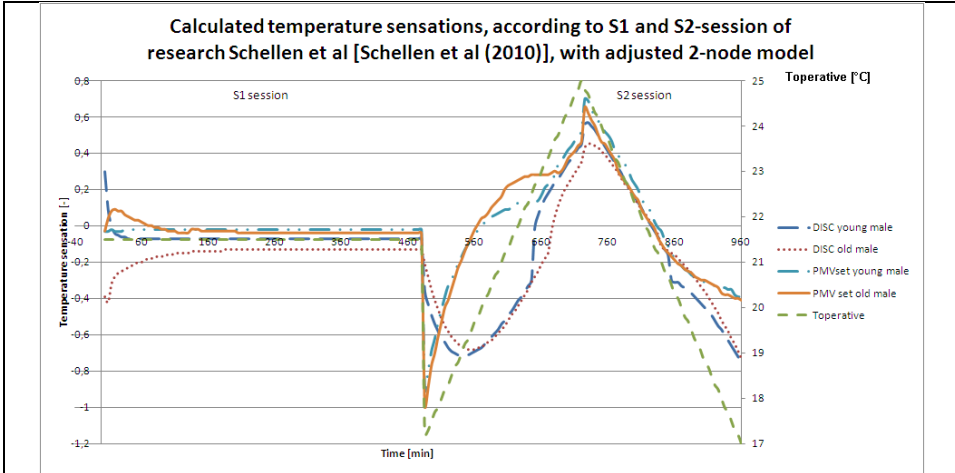

Figure 5.2.4c. Calculated thermal sensations S1 and S2 session with adjusted two-node model (this study).

The calculated PMV and PMVset thermal sensations, with the adjusted two-node model, appears to be in the same order of magnitude as the measured thermal sensations by Schellen et al. (199) (figures 5.2.4a to 5.3.4c).

Gonzalez (224)

This paper reviews laboratory studies and research needs in human physiology that will be important in specifying thermal acceptability; it compares these results with guidelines proposed by the Federal Energy Administration (FEA) for summer and winter months. Male and female subjects, in both younger and older age groups, were exposed while sedentary or slightly active, to fluctuating dry bulb temperature (at 50% relative humidity) and to constant dry bulb temperatures (at 40%, 60% and 80% relative humidity) in summer experiments. In winter experimental subjects were exposed to 20°C and colder environments and were allowed extra outer clothing to avoid cold discomfort. Clothing insulation was directly evaluated. In both studies evaluations of whole body thermal discomfort and thermal sensation were made; Additionally, in winter studies direct votes of acceptability by the subjects, as well as regional thermal sensation (face, trunk and extremities) were taken. A method of estimating preferred comfort and neutral thermal sensation temperatures is described for fluctuating air temperature conditions. The results of summer studies indicate that 60% relative humidity at 26,7°C is the maximum limit for thermal acceptability which corresponds to a 28 ET* or 2°C above the optimal ASHRAE neutral/comfort zone. The results of the winter experiments showed that the FEA winter temperature guideline lower limit (20°C) proved 80% acceptable. Specific groups of individuals have been identified for whom winter and summer guidelines will be wholly acceptable. Relative humidity in the first part of the experiments was kept constant at 50% and dry-bulb temperature altered ± 5 K from a starting temperature of 25°C with the room control set at an average rate of ± 0.3 K/min over a 2 hour period (224).

From the point of view of comfort this temperature fluctuation in the aforementioned did not meet the criterion of Sprague and McNall (225), as mentioned in the thesis of Fanger (84):

- $(cph) \cdot \Delta t^2 < 4.6 [^{\circ}C^2/hr]$

Herein is:

- Δt = The peak to peak amplitude of air temperature [$^{\circ}\text{C}$]
- cph = is the cycling frequency [hr^{-1}].

According to Gonzalez the differences in thermoregulatory response between sexes as well as between the elderly and non-elderly, as shown in several investigations of different researchers, become apparent especially under fluctuating temperature conditions (224). This could be the reason why Fanger did not find any differences, other than a difference in metabolic rate and evaporation, taken into account in advance.

Sometimes fluctuations in air temperature may be beneficial because they may have a stimulating and invigorating effect on the organism. However, this assertion is purely speculative and lacks documentation. In rooms occupied by many persons, over a period, when the temperature fluctuates beyond the limits stated above creates a larger number of dissatisfied than when the temperature is kept constant, according to Fanger (84).

Equations for average thermal sensation estimates as a function of Standard Effective Temperature (SET^*), or Standard Operative Temperature (STO) at 50% relative humidity, with fluctuating temperature conditions, were developed for young females ($\text{Iclo}=0,3$), older females ($\text{Iclo}=0.5$) and young males ($\text{Iclo}=0.3$), in a summer situation. The regression equations are:

Young females (Age 22 ± 3 years)

- $\text{T}_{\text{sens}} = 0.360 \cdot \text{SET}^* - 8.57$

Older females (Age 44 ± 11 years)

- $\text{T}_{\text{sens}} = 0.318 \cdot \text{SET}^* - 8.01$

Young males (Age 25 ± 4 years)

- $\text{T}_{\text{sens}} = 0.232 \cdot \text{SET}^* - 5.15$.

Data from the elderly males were not yet available at the time of this part of the experiments.

The three regression equations are graphically displayed in figure 5.2.5. The green shaded area in figure 5.2.5 is the comfort zone, according to category B in NEN-EN-ISO-7730 (56), NPR-CR-1752 (22) and category II in NEN-EN-15251 (23).

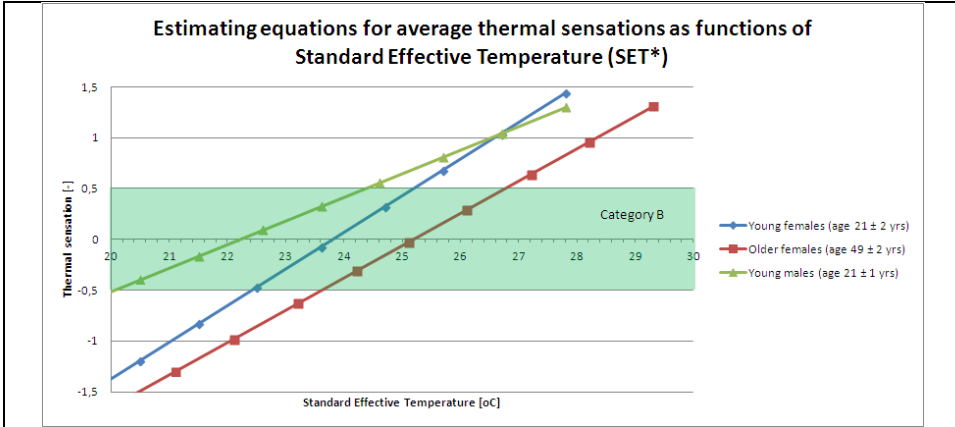

Figure 5.2.5. Regression equations.

The mean difference of the thermal sensation of older females with their younger counterparts is about 0.5 scale-unit. This agrees with the findings of Schellen et al. (199).

Rewriting the regression equations

It is possible to rewrite the aforementioned regression equations in:

Young females

- $T_{sens} = 1.100 \cdot PMV - 0.040$

Older females

- $T_{sens} = 0.972 \cdot PMV - 0.472$

Young Males

- $T_{sens} = 0.709 \cdot PMV + 0.347$

In figure 5.2.6 the SET*-regression equations are graphically displayed as well as the mean of the three SET*-regression equations and the Predicted Mean Vote (PMV), according to NEN-ISO-7730, as a function of the Standard Effective Temperature (SET*). The green shaded area in figure 5.2.6 is the comfort zone, according to category B in NEN-EN-ISO-7730 (56), NPR-CR-1752 (22) and category II in NEN-EN-15251 (23).

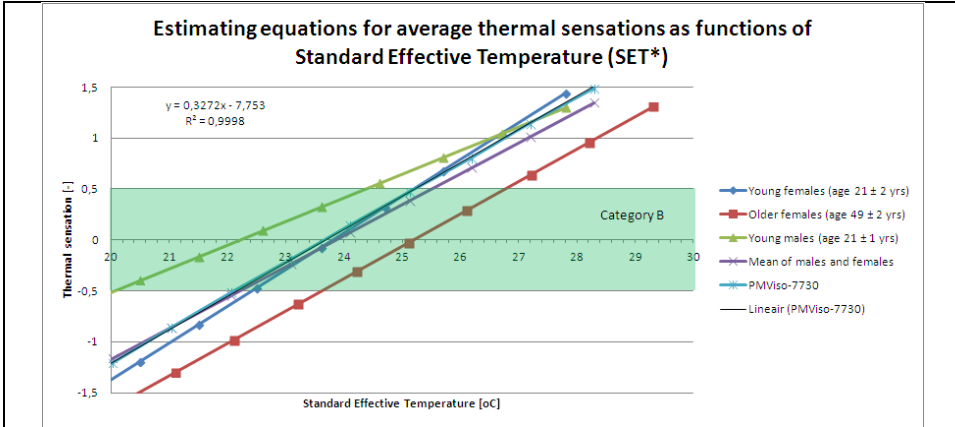

Figure 5.2.6. SET*-regression equations.

The mean of the three SET*-regression equations is almost the same as the line PMV, according to NEN-EN-ISO-7730, as a function of SET*. Therefore, it looks like that the Fanger model predicts well the mean of thermal sensation of the elderly and non elderly together. However, for the calculation of the thermal sensation of each of the groups of the elderly and non elderly separately one needs to correct the Predicted Mean Vote (PMV), according to NEN-EN-ISO 7730, with each of the PMV-regression equations above.

5.2.4 Discussion

Transients

Schellen et al. (199), in accordance with other researchers, found that for all slopes the relation between instantaneous mean thermal sensation and the prediction by the PMV-model (56) was in reasonably good agreement.

When the ambient temperature changes rapidly, the thermal sensation changes are far more rapid than the body temperatures. In a series of experiments by Gagge et al. (115), men exposed to sudden changes in temperature, immediately experienced thermal sensation changes when the air temperature changed, even though it took many minutes for the skin and deep body temperature to change. The sensation anticipated the changes in air temperature and the subject felt as warm as he would in steady state conditions in that air temperature, even though his physiological temperatures were nowhere near the steady-state value.

In transient conditions, therefore, thermal comfort may be predicted more accurately from a knowledge of the air temperature than from a knowledge of the skin and body temperatures. Rather surprisingly, this holds true for more normal conditions and several investigators have found higher correlations between warmth votes and air temperatures than between warmth votes and skin temperature (226).

Thermal sensation

A person cannot actually sense air temperature directly. All a person senses is the heat flow at his nerve endings, which are situated below the surface of the skin. It would be desirable if a person's sensation of warmth and comfort is to predict entirely from a knowledge of his physical state. This has proved surprisingly difficult to do and it is often possible to predict warmth sensation more accurately from the air temperature than from mean skin (e.g. DISCC-scale in the Gagge model (55) and deep body temperature (e.g. Tsens and the DISC-scale in the

Gagge model) (226) or even the degree of sweating (e.g. DISCW- and DISC-scale in the Gagge model).

That the aforementioned is consistent with the experiments of Gonzalez (224), is shown in figures 5.2.7. In figure 5.2.7a the results of Gonzalez are displayed. In figure 5.2.7b the calculation results of the adjusted two-node model are displayed.

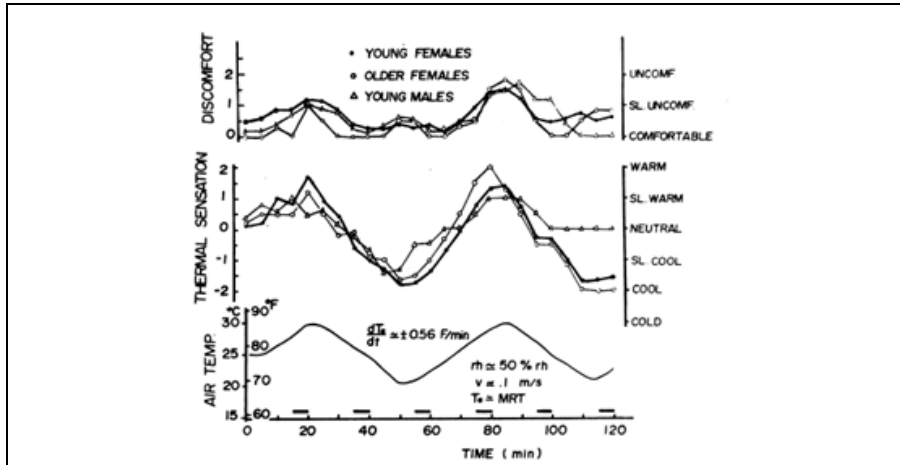

Figure 5.2.7a. Results Gonzalez (224).

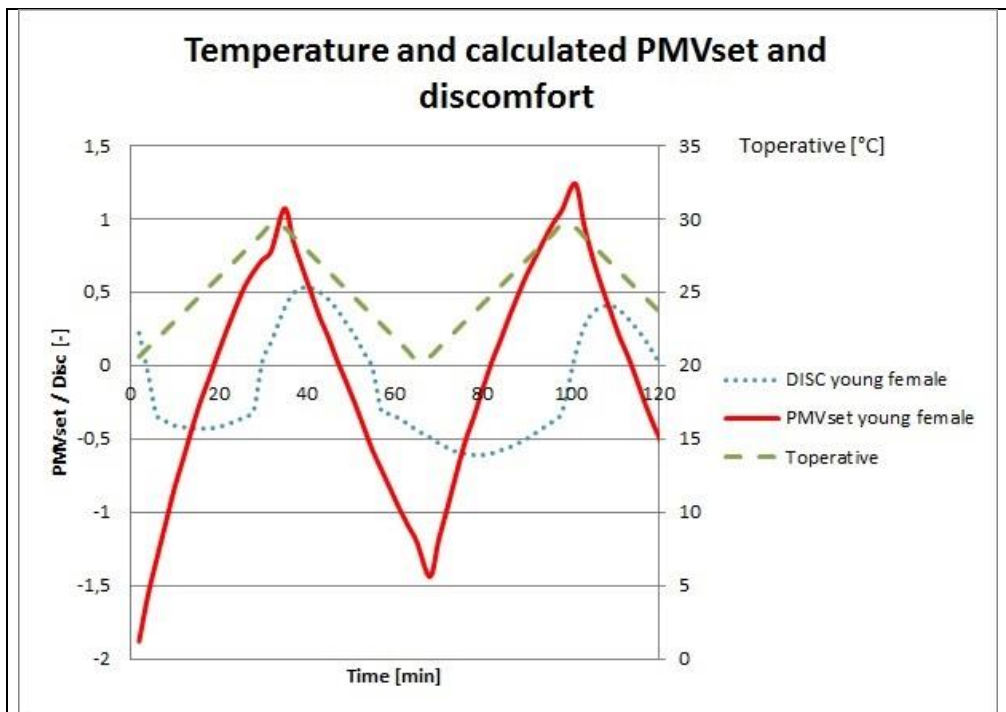

Figure 5.2.7b. Calculation results of the adjusted two-node model (this study).

The results of Gonzalez (figure 5.2.7a) show that the thermal sensation immediately changes as the air temperature changes. However in the case of the simulation with the adjusted two-node model (figure 5.2.7b) the calculated discomfort (DISC) is not present but only the calculated PMVset, as developed by Gagge et al. (55), is present. The calculated DISC is a function of the mean body temperature and the degree of sweating (55). The PMVset however is a function of the Standard Effective Temperature (SET) (55) and the external thermal load on the body. The Standard Effective Temperature (SET) is defined as the dry bulb temperature of a hypothetical isothermal environment at 50% relative humidity in which a human subject, while wearing clothing, standard for the activity concerned, would have the same skin wetness and heat exchange at the skin surface as he would have in the actual test environment. The PMVset is proposed by Gagge for any dry or humid environment by simply replacing operative temperature in Fanger's comfort equation with SET. With this the classical difference between PMV and DISC as predictors of warm discomfort, occurring at very high and very low humidity, is solved, according to Gagge et al. (55).

The conclusion of Schellen et al. (199) and other researchers [mentioned in Schellen et al. (199)] that the Predicted Mean Vote (PMV) might also be applicable for certain transient conditions is in accordance with the experiments of Gonzalez (224).

5.2.5 Conclusion

The relationship between the percentage of dissatisfied and the predicted mean vote in the Fanger model was developed on the basis of an analysis of the experiment with 128 Danish elderly and 128 Danish non elderly as well as the American experiments of Nevin et al. (227) and Rohles (228) who used mainly young subjects. The experiments of Fanger (84); chapter 3 in his book) showed that there was no significant difference in the preferred temperature between the elderly and the non-elderly in the steady state situation. However a possible difference in the percentage dissatisfied between the elderly and non elderly was not shown by Fanger. On the other hand Hwang and Chen (191) developed two relationships, one for the elderly and one for non-elderly, which offered the possibility of difference between the elderly and non-elderly regarding the percentage of dissatisfied.

According to Gonzalez the differences in thermoregulatory response between sexes and the elderly and non-elderly, as shown in several investigations of different researchers, become apparent especially under fluctuating temperature conditions (224). This could be the reason why Fanger did not find any differences, other than a difference in metabolic rate and evaporation that in advance can be taken into account.

The Fanger model predicts well the mean of thermal sensation of the elderly and non elderly together, in steady state and fluctuating temperature conditions. However for the calculation of the thermal sensation of each of the groups of the elderly and non elderly separately one needs to correct the Predicted Mean Vote (PMV),

The results of the experiments of Schellen et al. (199) (see figure 5.2.3a), as well as the PMV-calculations with the adjusted two-node model (see figure 5.2.3b), indicated that thermal sensation of the elderly was, in general, 0.5 scale units lower in comparison with their younger counterparts. A temperature drift up to ± 2 K/h in the range of 17–25 °C was assessed as applicable and will not lead to unacceptable conditions.

In the experiments of Gonzalez (224) a dry-bulb temperature alternating ± 5 K from a starting temperature of 25°C, with the room control set at an average rate of ± 0.3 K/min, over a 2

hour period, resulted also in a thermal sensation of older females of about 0.5 scale unit lower in comparison with the young females.

Furthermore:

- SET^* preferred temperature is significantly different between the young male and both female groups
- The SET^* preferred temperature for younger females is lower as compared with the older female group. This may be the result of a lower metabolic heat production in older females
- Young females and older females have a significantly higher warmth sensitivity than the male group
- There was no significant difference in warmth sensitivity between the young and older groups
- In the winter study, the older individuals complained less of the cold than the younger females and had less cool discomfort at both 20°C and 15°C, which agrees with the findings of Hwang and Chen (191).

The decrease found in the evaporative heat loss for the elderly is a reason for concern because of the diminished vasodilations, vasoconstrictions and shivering response, for example in the case of temperature overshoots of the comfort zone. The experiments of Gonzalez showed that elderly are not excessively disturbed by warm situations. However, because of the general lower physical fitness and resulting lower sweat secretion and poor skin circulation, the level of skin wetness does not serve as an early cue for thermal discomfort in the elderly as it does for more fit individuals. Other symptoms of distress (i.e. syncope, headache, etc.) are less ostensible and can occur at higher levels of humidity and ambient temperature. Therefore, special consideration should be given to the elderly (224).

The calculated PMV and PMV_{set} thermal sensations, with the adjusted two-node model, appears to be in the same order of magnitude as the observed thermal sensations by Schellen et al. (199) and Gonzalez (224).

The Predicted Mean Vote (PMV) might also be applicable for certain transient conditions, according to experiments of Schellen et al. (199) and other researchers (cited in the article of Schellen et al.).

Havenith (223) mentions that his study was to determine the possibilities of individualization, wherein the average gain was less important than the differentiation in gain between individuals. For that reason this topic was not further pursued. Leads to follow on this subject are e.g. sweat evaporative efficiency and sweat delay. In order to provide a better understanding of the processes which take place in heat exposure, control equations with realistic control parameters would obviously be preferable and therefore this point should be addressed in future. However the introduction of individual characteristics in the computer simulation model of human thermoregulation significantly contributes to the model's predictive power for individual's heat stress response. Nevertheless, still a substantial part of the differences in individual responses remains unexplained (223).

Since the various subgroups of elderly are increasing in number disproportionately to other age groups, adapting the existing thermophysiological human models, for predicting the thermal response of people depending on age and sex, is important (220), (223), Rida et al. (229), Takada et al. (230), Zhang et al. (231), Van Marken Lichtenbelt et al. (232). In this way, useful insights can be gained, from modelling the thermal behavior and response patterns of elderly, for the future design of buildings and climate installations (220).

The elderly and non-elderly experience the indoor climate differently. The elderly have a lower tolerance than the non-elderly for uncomfortable conditions. The proper performance requirements for the well-being of the elderly are evident. Therefore as a matter of urgency the standards and guidelines are to be adapted (219).

6 Epilogue

6.1 Answering the research questions

The aim of this PhD thesis was to create models that predict well-being, perception and performance change, to assist practitioners, that are closer to reality than existing models. This is of importance as the improvement of the indoor environment could be seen as an investment in the quality of the work environment, which could pay off in a better performance, higher comfort or better health.

To contribute to this aim studies are performed and models are made of the effects of interior and system changes on elements that are of interest to all stakeholders in the housing process in the previous chapters. The key questions are:

- Is improvement of current models possible to define more precise the relationship between the physical aspects of the indoor environment and the perception of those aspects?
- Is improvement of current models possible to define more precise the predicted percentage of dissatisfied and the performance change of people?

There are many ways to model the effect of the environment on the human. In this PhD-thesis the original S-O-R model of Woodworth (13) is chosen, which is still used much in the psychology and marketing field of study. In describing the effect of the environment there are many models which are probably more precise like for instance the adapted S-O-R-model of Jacobi (233). For organizing the chapters of this thesis the original S-O-R-model was appropriate. Also, for the subjects of perception and performance change it was useful, but for applications like the holistic approach to the environment the models of for instance Ahmadpour et al. (234), Bazley (44) or Clements-Croome (235) are more useful.

Regarding the first question this PhD thesis shows that it is possible to improve current models to define more precise the influence of the physical aspects of the indoor environment on perception for the professional practice. The chapters 2.3, 2.4, 3.2, 5.1 and 5.2 for instance show, depending on the indoor environmental aspect, new quantitative relationships and the improvement of existing models to evaluate more precise the influence of the physical environment on perception. For instance by adding clothing and thermal sensation, suitable for the assessment of dynamic thermal conditions (the so called Dynamic thermal sensation (DTS) and Transient Thermal Sensation (TTS)) to the Stolwijk model (107) the scope of the thermophysiological model has become larger than it was before. The model is hereby suitable for the simulation of the thermal sensation and clothing under dynamic thermal conditions. Before this adjustments, and the assembling of a computer program, it was not possible to simulate dynamic thermal conditions with clothing and thermal sensation with the Stolwijk model. This opens the way to further improvement and use of the Stolwijk model in the professional practice. Of course specific validation still needs to be done to check if the predicted effects are really found in practice. The model in chapter 3.2 shows the quantitative relationship between the freshness of the air and the temperature and humidity of the polluted air, caused by the presence of people. The model corresponds with the olf-decipol method of Fanger (236), which however does not take into account the temperature and humidity of the air. This chapter showed by applying the method in practice that complaints concerning the air are not well explained by the evaluation method of NPR-CR-1752 (22), based on carbon dioxide concentration measurements. The evaluation method based on the freshness of the air fitted better with the complaints about the air quality in practice, as is shown chapter 3.2.13, which might explain the relevance of the evaluation method based on the freshness of the air. Further evaluation is necessary to validate the accuracy of the model in practice.

In addition, in chapter 3.2.12. an equation is derived between the accumulation of fatigue and the percentage of dissatisfied due to the perceived air quality. In chapter 5.1 it is shown in

which way the speech intelligibility as a function of age is to be calculated, on the basis of the STI method (204). In chapter 5.2, based on a for this study assembled computerprogram, the research of Gonzalez (224) and the research of Schellen et al. (199), it is shown that the thermal sensation of the elderly is in general 0.5 scale units lower in comparison with their younger counterparts, in the case of a moderate temperature drift. It is shown that the difference, between elderly and non-elderly, in thermal comfort is to quantify, related to the Fanger model. This is modelled in chapter 5.2, also here a precise check whether the predicted outcomes are corresponding with practice still needs to be done.

Regarding the second question this PhD thesis shows that it is possible to improve current models to come with a prediction closer to the percentage of dissatisfied. For instance in chapter 2.3 it is shown, by research of Fiala, that the Dynamic thermal sensation (DTS) and the Predicted Mean Vote (PMV) are in general agreement with each other and that it is possible to calculate the Predicted Percentage of Dissatisfied (PPD) on the basis of the DTS. Chapter 2.4 describes a proposal for a new model for determining the thermal sensation in a step change transient homogeneous thermal environment that is more accurate and has a larger scope than the DTS-model of Fiala et al. (18). A suggestion is to standardize the classic and known experiments in the literature in future, on the basis of which reliable equations can be derived, so that for each dynamic human thermophysiological model equivalent to or more accurate than the Stolwijk model, the appropriate coefficients can be determined on the basis of the here proposed TTS-model. Appendix 13.2 focuses on a combination of new relationships with regard of predicted percentage of dissatisfied due to draught. With this combination of new relationships, programmed in a CFD-model, the scope of the here assembled model is larger than the current draught model in NEN-EN-ISO-7730. In chapter 3.1 a new relationship is derived between the carbon dioxide concentration and the predicted percentage of dissatisfied due to the perceived air quality. This new relationship has a larger scope, with regard to metabolic rate, than the relationship displayed in NPR-CR-1752, which is only valid for a metabolic rate of 1.1 met. In chapter 3.2 a new relationship is derived between the freshness of the air and the predicted percentage of dissatisfied due to the perceived air quality. The model in chapter 4.2 shows new quantitative relationships between the equivalent background noise level and the predicted percentage of dissatisfied due to environmental noise (viz. road traffic, rail traffic, industry and air traffic). There is still information missing in this model with regard of noise from restaurants, cafes and bars and all sorts of noise produced inside a building (e.g. floor impact noise, bathroom drainage noise, conversation noise and music). In chapter 5.2 relationships are shown for the Predicted Percentage of Dissatisfied and the Mean Thermal Sensation Vote for both elderly and non-elderly. Further evaluation is necessary to validate the accuracy of the relationships in practice.

Regarding the second question this PhD thesis indicates that human performance loss can be influenced by discomfort. The models and the for this study assembled computerprograms in chapter , 2.2, 3, 4.1 and appendix 13.1 (viz. based on the performance loss equation derived by Roelofsen (46)) show quantitative relationships between the performance loss of people and thermal sensation or the perceived air quality or the speech intelligibility. In chapter 2.2 several performance loss equations as a function of thermal sensation, with different scopes, are implemented in one for this study assembled computer program, based on an in the literature validated thermophysiological human model, usable for the professional practice. In the chapters 3.1 and 3.2 several equations, with different scopes, are shown in which the performance loss is a function of the predicted percentage of dissatisfied due to the perceived air quality. Striking is the greater influence of the air quality on performance in the case of non-routine work, for which creative thinking is important (eg. Proof reading). In chapter 4.1 a

new quantitative relationship is shown between the performance loss and the speech intelligibility. We could establish mathematically how much these aspects do change the performance of people. The question is however whether this is found in reality as well. The difficulty in checking this is that many factors influence comfort and performance (9).

The reflection on the studies in this PhD show that especially verification of the models as future research is important to check the models, optimize these or replace models by other ones.

6.2 Validity and reliability

The validity of the proposed models is partly shown by the similarity between the results from the experimental data and the data calculated by the proposed and derived models. It is revealed that the derived models successfully predict the perception or the percentage of dissatisfied or the performance change, depending on the subject and consideration. Further research however have to show the statistical proof of the findings in practice.

Performance loss

Since performance change with investments in the indoor environment are of great interest to investors, designers, facility managers, construction managers, project developers and scientists, the results of scientific research relating performance loss with parameters of the built environment can provide valuable information to enhance human performance. Thus it makes sense to develop relationships that can and will be used within the framework of feasibility studies, design decisions, environmental controls and compiling and checking performance specifications, as well as handling complaints.

Most of the performance loss relationships, with the exception of the last study of Mohamed and Korb (48) as well as the study of Jensen et al. (50), are developed under laboratory circumstances without the influence of interaction of the affecting factors as mentioned in figure 6.2.1.

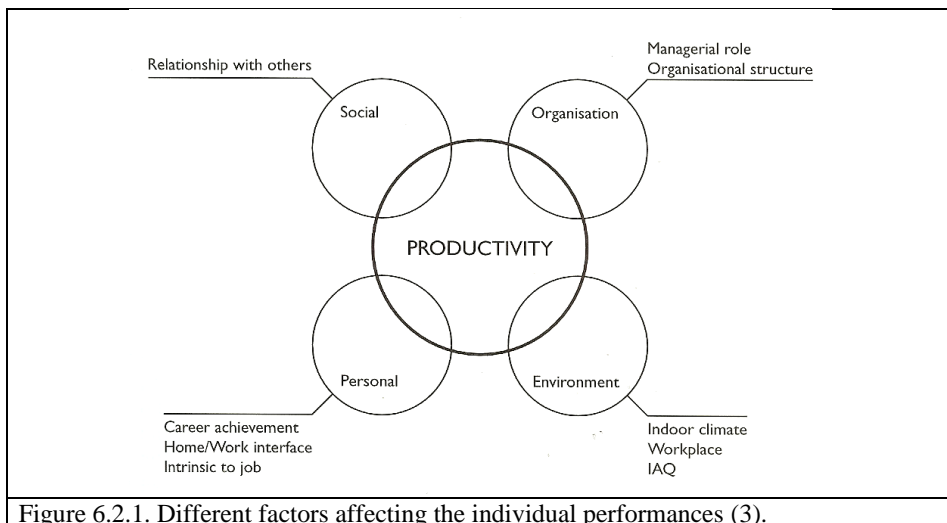

Figure 6.2.1. Different factors affecting the individual performances (3).

Some studies are based on only a few often young subjects (e.g. Lan et al. (51) used 12 subjects; average age 23 ± 2 years) and relatively short exposure times (e.g. 80 minutes). Other

studies are although based on more subjects still only applicable on young subjects (204 students; age: 19-26 years) and heat stress situations, like the research of Zhao et al. (52). The study of Berglund and Gonzalez (54) is based on an exposure time of three hours and subjects in the age of 18 - 35 years. The relationship of Jensen et al. is developed on the basis of 12.700 subjects and an age range of ≥ 14 years (N.B.: even an age ≥ 55 years; exposure time unknown), however only for a mathematical task, namely the addition of numbers. Also in connection with the precision one has to have knowledge about the research results and how to interpret the findings.

The economic consequences of even relatively small increases in performance could have a short payback time of an investment in improving the indoor environment (28), (31), (46), (237), (97). Often in rentability calculations assumptions have to be taken, like for instance the interest rate, price increases, clo-value and metabolic rate. The more assumptions the less realistic estimations of the performance calculations can be expected. Therefore it is necessary that the uncertainty is evaluated in the performance calculations of the performance tools, on the basis of a sensitivity analysis for instance. Important is that the performance relationships of course are used for the tasks and circumstances for which they are developed. Besides this, it is advised to use the relationships only in the case of comparative studies.

If

- a performance increase of 5-15% and a reduction in absenteeism of 2.5% can be achieved by improving the indoor environmental quality
- a minor 1% increase in office work can off-set the annual costs of ventilating the building
- the full costs of installation and running the buildings can be off-set by productivity gains of just under 10%
- doubling the outdoor air supply rate can reduce illness and sick leave prevalence roughly by 10%, and increase office work by roughly 1.5%
- every 10% reduction in the percentage of dissatisfied with air quality can increase the performance of office work by roughly 1%
- a reduction of indoor air temperatures above 22°C by 1% can roughly increase the performance by office work by 1%
- the pay-back time for investments to improve indoor environmental quality is generally below two years

, as for instance is claimed by ISSO/SBR Guideline Healthy Buildings (237) and REHVA Guidebook no.6 (31) on the basis of different scientific studies, there is no economical impediment for not prioritizing the quality of the indoor environment. However because the interaction of the organizational, psychosocial, personal and indoor environmental quality effects (see figure 6.2.1) are still not thoroughly investigated, it is however still up to especially the designers to convince other stakeholders that a good indoor environment, created already in the design phase, contributes to an increased employee performance (31).

Since performance change with investments in the indoor environment are of great interest to investors, designers, facility managers, construction managers, project developers and scientists, the results of scientific research relating performance loss with parameters of the built environment can provide valuable information to enhance human performance. Thus it makes sense to develop relationships that can and will be used within the framework of feasibility studies, design decisions, environmental controls and compiling and checking performance specifications, as well as handling complaints.

Standardization

A global standardization of indicators for the performance loss in the built environment for activities and a mix of activities by sector, such as those expected in offices, nursing homes, schools, and so on, may solve the problem of the unequivocalness. For that the International Organization for Standardization (ISO) has clearly a role to play, so that innovation, but above all the improvement and the pursuit of high-value, within the built environment will be given a worldwide stimulus. Increasingly there are initiatives to recognize that focus on moving towards achieving a worldwide consensus on an agreed method of measuring productivity of people in organizations in practice (5).

A suggestion is to standardize the classic and known experiments in the literature in future, with regard of this subject, on the basis of which reliable equations are to derive. In this way for each dynamic thermophysiological human model, equivalent to or more advanced than the Stolwijk model, the appropriate coefficients are to determine on the basis of the here proposed TTS-model.

6.3 Applicability

In chapter 2.2, based on different scientific studies, an effect of the indoor thermal environment on mental and physical performance is found. In REHVA Guidebook no.6 (31) as well as in appendix 13.1 it is shown that the economic consequences of the effect can be large. Taking this into consideration, for Grontmij this was a reason to use the effects of indoor environment quality on performance especially in the initiative/programming phase, design phase and maintenance phase of the building process (see figure 6.3.1) to estimate the building costs (Programming / Design) and monitor the energy and indoor environment situation in buildings in the real situation (Maintenance), which again may justify investments in solutions that improve the indoor environment.

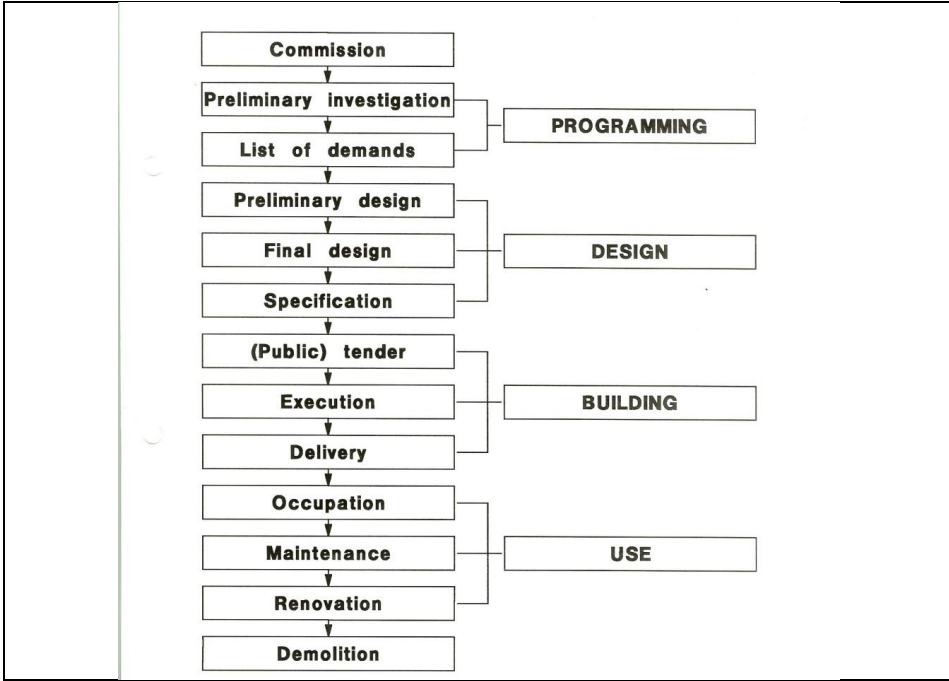

Figure 6.3.1. Building process.

6.4 Accessibility

Accessibility of the calculation method is a problem of implementing performance calculations in practice. After all one has to have knowledge about the research results and how to interpret the findings. To stimulate a more extensive utilization of the performance calculations in the building process the performance relationships are an integrated part of the Grontmij human and building simulation software and monitoring software, to be used by the specialists in the field of study.

6.5 Main outcomes and food for further research per chapter

Thermal indoor environment

The single computer model proposed in chapter 2.2 of this thesis is especially usable in the situation of comparative studies. For instance in the early stages of the design process, the computer model assists in choosing between scenarios to make a better or correct (design) decisions regarding the thermal aspects of the indoor environment, whether or not in combination with validated building simulation models. The use of a dynamic thermophysiological human model, in combination with the performance loss and buildings simulation models, enables the evaluation of the thermal influence of architectural and building service related adjustments for people and organizations. The use of a combination of models, as is shown in appendix 13.1 in this thesis, makes it even possible to negotiate solutions and better balance investments with regards to profits of workable hours. In the Netherlands, a new method (Adaptive Temperature Limits method (238)) has been developed to be able to evaluate the indoor thermal comfort in office buildings. This method, which also distinguishes three comfort classes, is not used in these comparisons since buildings with climate installations, without the use of windows, to maintain the indoor thermal climate, show large discrepancies

compared to the current GBA evaluation method, on the basis of which most office buildings in the Netherlands are designed. Furthermore a study of Hensen and Centerova (239) shows that in a major part of the year (October – May) in the Netherlands (and the Czech Republic) the adaptive thermal comfort is not relevant. More information can be found in (240) and (239). The above conclusions are drawn on the basis of models. It is scientifically interesting to validate the models and see if predicted effects are found in practice. There is a need for this future research as relationships can be improved or replaced by new ones.

There has been a growing demand from research and the industry for models predicting human thermophysiological responses. Reliable and detailed thermophysiological human models are necessary for the design of the indoor thermal climate. The Stolwijk model (107), still the basis and inspiration for many other thermophysiological human models (99), as compared to the Gagge model (55) that is used in the computer model mentioned above, is more extensive in scope, e.g. because the heat balance of the body is divided into the head, the trunk, arms, hands, legs and feet. In addition, the aforementioned body parts are divided into a core, a muscle layer, a fat layer and a skin layer. By adding clothing and thermal sensation and connected to this the percentage of dissatisfied, as is done in chapter 2.3 and 2.4 in this thesis, the scope of the Stolwijk model has become considerably larger than it was before.

As a result of the improvement of the calculation of the skin temperature, based on the investigation of Munir et al. (103) the extent to which the Stolwijk model is suitable for the evaluation of local discomfort (e.g. thermal sensation of the extremities or draught, like is done in appendix 13.2 of this thesis with the use of a CFD-model) asks for further study. Further research is needed how to modify the Stolwijk model with for instance:

- individual characteristics, like is done in chapter 5.2 of this thesis with regard of the Gagge model (55), so the differences between subpopulations (e.g. young and old) can be assessed and
- performance loss models, as well as
- a more accurate whole-body thermal sensation model, for the non-steady state situation, as is proposed in chapter 2.4 and
- a local thermal sensation model, equivalent to or more accurate than the thermal sensation and comfort model of Zhang et al. (127), (128) and with a larger scope (e.g. Metabolism ≥ 1 met).

The relationship between the indoor environment, perception and human performance makes it possible to design on the basis of productivity improvement, resulting in a comfortable working environment and a consistent financial advantage for the organisation. If the indoor environment is assessed in the context of comfort and performance, the participants in the housing process who are generally less interested in aspects like wellbeing will eventually incorporate investments in the quality of the workplace in their objects (in connection with the ability to sell and lease real-estate).

Air quality

The olf-decibel method of Fanger (21) uses the air quality assessed through the human nose by a group of people (panel) that is trained in observing the air-quality. Although not perfect, there is to this day no better method developed for the evaluation of the perceived indoor air quality. For the time being there is no handy and reliable electronically device in trade that, quickly, easily, used by one person and without much costs, measures the perceived indoor air quality. This makes the evaluation of the perceived air quality in practice difficult. As long as this situation applies it is obvious to consider to which extent, with relatively simple to determine indicators such as the CO- and the CO₂-percentage, a right connection can be found with

the latest insights (141), (142). Chapter 3.1 of this thesis introduces an equation which shows that the percentage of dissatisfied due to the perceived indoor air quality is a function of the CO₂ concentration difference between the air in the occupied space and the supplied fresh air, as well as the amount of fresh air, supplied to each person, when the air is polluted by the presence of people. The equation is valid for a metabolism equal to or larger than 1,1 met, unlike the equation, based on the CO₂ concentration difference, mentioned in NPR-CR-1752 (22), which is only valid for a metabolism of 1,1 met. In chapter 3.2 of this thesis it is shown, with regard to the research of Berglund and Cain (138), that the freshness of the air, polluted by people, is quite accurately calculated on the basis of the air temperature, the relative air humidity as well as the quotient of the amount of air pollution (in olf) and the fresh air supplied. By using the aforementioned derived CO₂-difference equation the freshness equation, based on air temperature, relative air humidity and the air pollution, is rewritten in an equation based on the air temperature, the relative air humidity and the CO₂-concentration difference. The method described here lends itself to examine the perceived air pollution by persons, based on a few relatively simple measurements of environmental parameters without having to use a group of trained people on air quality (so called odor panels) (142). This method leads to a simplification of an in practice to perform air quality research, as long as there is no handy and reliable measuring device available for the measurement of the perceived air quality, as a function of the temperature and the humidity of the air and the air pollution, when air is polluted by the presence of people (142). In two practical applications (see chapter 3.2) it is shown that the complaints concerning the air quality were not well explained by the evaluation method of (NPR-)CR-1752. The evaluation method based on the freshness of the air however fitted better with the complaints about the noticeable stale air quality in the buildings. The air pollution, polluted by other pollution sources, needs to be further investigated. The Dutch regulations for indoor air quality however consider only the air pollution that people cause, since this source is unavoidable. Other air pollution sources affecting indoor air quality (such as interior design, installations, the building and the outdoor air) in the Dutch laws and regulations are disregarded and are the responsibility of the market parties (144).

Nowadays, there are four tasks which the building services should achieve to promote good health (241):

- Minimalisation of infection risk
- Prevention of chronic diseases
- Support to well-being
- Lower use of resources.

In this manner the building services are no longer classified by the nature of the installed material but by the function to pursue (241).

The aforementioned task list calls for new starting points for the building services in order to reduce new health risks, increase well-being and to minimise the use of resources in an increasingly aging and urbanising society. The aforementioned changes are however only to be employed by usage of starting points more focused on persons (241). This calls for a greater integration of knowledge on building services and health. The building service engineers need knowledge of biology, chemistry, physiology, epidemiology and psychology to meet these new challenges (241). For the assessment of energy saving measures both the implications to the environment as those for the public health are of interest (241), (144).

The need for fresh air implies a preference for radiant heating and cool air above convective heating, after all a high temperature and high humidity of the air reduces the evaporation to the mucosal surface, which results in discomfort (41), (chapter 3.2). The result is probably a more enjoyable indoor air quality, and reduces the use of energy. If, for that matter, a climate

control system is deliberately designed on the basis of air temperature transgressions, one needs to realize that the air temperature transgressions strongly affect the freshness of the air and thus the percentage of dissatisfied due to the perceived air quality (chapter 3.2). The evaluation of the thermal indoor climate and the perceived air quality are in that situation not to be considered independently of each other (chapter 3.2). In that case it is advised to use, in the design stage, not only air temperature transgression calculations but also transgression calculations of the percentage of dissatisfied due to the perceived air quality to evaluate the indoor environment correctly (chapter 3.2). Ergo, this means another way of designing than is usual in the current professional practice.

Most comfort studies and models are based on college-age persons (84) and the assumption that people are exposed to only one indoor environmental aspect at a time (33). However, people in buildings differ in age and are exposed to a combination of environmental aspects. Studies show that well-being of people on one indoor environmental aspect can be influenced by another indoor environmental aspect (33). The study of the freshness of the indoor air, in chapter 3.2 of this thesis, is an example of this phenomenon. It will be clear that a lot more whole body and body part exposure studies need to be executed before there is enough knowledge to understand and quantify all combinations. In this context environmental psychology will be increasingly important within the disciplines that deal with the built environment. The current methods of risk assessment are still inadequate in this regard. Several researchers support a more holistic way of evaluating indoor environments and argue that a clear understanding of how the human body and mind receive, perceive and respond to indoor conditions is needed (242), (8), (30), (27), (32), (243), (6).

Acoustics

In practice, within the housing proces, it is desirable to divide the aspects of the indoor environment into quality categories (165), (166). In the present situation it seems that a classification for noise and sound insulation according to, for example, NEN-1070 (167) may be a more practical approach. The classification in this standard is, principally, based upon an interval subdivision of the percentage of disturbed by noise together with an associated qualification description (see annex C in NEN-1070). However, in view of European developments (e.g. CR-1752 (22), EN-15251 Ontw. (168) and (NEN-)EN-15251 (23)) considering classification of the indoor environment based upon the percentage of dissatisfied, it makes sense to use this parameter (viz. the percentage of dissatisfied) for the evaluation of noise too. Chapter 4.2 in this thesis proposes a first step to develop a method to evaluate and classify environmental noise, conforming to NEN-EN-15251 (23) and NPR-CR-1752 (22), in a built-up area based upon the percentage of dissatisfied related to the equivalent background noise. The model could be extended (e.g. the noise from restaurants, cafes and bars) and the same could be done for all sorts of noise produced inside a building (e.g. floor impact noise, bathroom drainage noise, conversation noise and music). Furthermore in chapter 4.1 of this thesis it is shown that it is possible to model the performance losses, as a result of adjacent conversations, with various desk layouts in an open-plan office. In chapter 5.1 a correction method is shown to predict speech intelligibility as a function of age. However further investigation is needed into the reliability, the applicability and the verification of the models.

Age

If the society has the opinion that older people should work longer and should take care for themselves longer, the built environment, and particularly the housing process has different requirements for health than young people. Adapting to this demand is described in the chapters 5.1 and 5.2 of this thesis. To which extent a built environment has influence on the health

and the performance of older people and health care professionals is not yet answered. More research is needed than considered within the framework of this study.

However building with care for health offers the possibility to:

- reduce the chance of disease and (the feeling of) insecurity,
- stimulate physical and mental activity,
- offer support in the daily work and life operations.

It increases the possibility of self-care and informal care and increases the quality of professional care (184). Viewed from this perspective the right performance requirements for the well-being of elderly are evident (184), (174). The performance requirements of the indoor environment aspects are not or insufficiently been studied regarding quality of life, care and health (184). This research still needs to be performed. The conducted surveys up to now show that an unhealthy environment burdens staff in charge and has a negative impact on the functioning and recovery of elderly and patients (184). Improving the built environment, makes it a remarkable cost-efficient way to support the performance of employees, the recovery of patients and the well being of elderly. These characteristics serve to be of influence on the design and operation of care institutions and nursing homes. The relationship between the physical environment and the aforementioned characteristics offers the possibility to design on performance improvement resulting in a green and healthy environment for the users and a consistent financial benefit to the organization.

Due to new ways of working in buildings and an ageing population there is a strong need for knowledge on the impact of the individual differences (e.g. sex and age) on the well-being and performance of people working in an organization. There is a need for adapting the existing thermophysiological human models to predict the thermal response of people depending on age and sex, as described in chapter 5.2 of this thesis. This is important because various subgroups of elderly are increasing in number disproportionate to other age groups. Useful insights can be gained, from modelling the thermal behavior and response patterns of elderly, for the future design of buildings and climate installations. The elderly and non-elderly experience the indoor climate different. The elderly have a lower tolerance than the non-elderly for uncomfortable conditions (191). The proper performance requirements for the well-being of the elderly are evident. Therefore the models, standards and guidelines should be adapted. A first translation into a guideline for the indoor environment (acoustics, light, air quality and the indoor thermal climate) as a function of age is given in chapter 5.1.

In addition to the previous studies, there are several other challenges to be tackled before a generally applicable model can be developed in the assessment of the comfort and performance differences in all design considerations of the indoor environment.

Future research is needed to verify the models and to generate input for better models, but this PhD thesis shows that much knowledge can be integrated in the current models making predictions more accurate and probably valuable. The predictions could be more precise and show potential effects on performance, comfort and satisfaction making even calculations on return on investments possible.

7 Summary

Designing on the basis of well-being caused by the indoor environment is an opportunity for companies as it has possibilities for comfort and productivity enhancement. There is much knowledge in the scientific literature to make more informed decisions than now. The problem however is that the latest knowledge is not available in existing models to predict a comfortable and productive indoor environment by designers of buildings and climate installations.

This thesis is a capita selecta of studies, each with the aim of developing a better model for predicting indoor environmental quality, based on available knowledge. With the improved models it is better to estimate the perception, the percentage of dissatisfied or the change in performance due to the indoor environment.

The key questions of this PhD-thesis are:

- Is improvement of current models possible to define more precise the relationship between the physical aspects of the indoor environment and the perception of those aspects?
- Is improvement of current models possible to define more precise the percentage of dissatisfied and the change of performance of people?

Regarding the first question this PhD thesis shows that it is possible to improve current models to define more precise the influence of the physical aspects of the indoor environment on discomfort. The chapters 2.3, 2.4, 3.2, 5.1 and 5.2 for instance show, dependent on the indoor environment aspect, new quantitative relationships and the improvement of existing models to evaluate more precise the influence of the physical environment on the human perception and by extension comfort.

For instance by adding clothing and thermal sensation, suitable for the assessment of dynamic thermal conditions (the so called Dynamic thermal sensation (DTS) and Transient Thermal Sensation (TTS)), to the Stolwijk model (107) the scope of the model has become larger than it was before. The model is hereby suitable for the simulation of the thermal sensation and clothing under dynamic thermal conditions. Before this adjustments, and the assembling of a computer program, it was not possible to simulate dynamic thermal conditions with clothing and thermal sensation with the Stolwijk model.

The model in chapter 3.2 shows the quantitative relationship between the freshness of the air and the temperature and humidity of the polluted air, caused by the presence of people. The model corresponds with the olf-decipol method of Fanger (236), which however does not take into account the temperature and humidity of the air. In practice complaints concerning the air are not well explained by the evaluation method of NPR-CR-1752 (22), based on carbon dioxide concentration measurements. The evaluation method based on the freshness of the air however fits better with the complaints about the air quality in practice based on comparison with data in the literature. Also an equation is derived between the accumulation of fatigue and the percentage of dissatisfied due to the perceived air quality.

In chapter 5.1 it is shown in which way the speech intelligibility as a function of age is to be calculated, on the basis of the STI method (204). In chapter 5.2, based on a for this study assembled computerprogram, the research of Gonzalez (224) and the research of Schellen et al. (199), it is shown that the thermal sensation of the elderly is, in general 0,5 scale units, lower in comparison with their younger counterparts, in the case of a moderate temperature drift. It is shown that the difference, between elderly and non-elderly, in thermal comfort is to quantify, related to the Fanger model.

Regarding the first part of the second question this PhD thesis shows that it is possible to improve current models to define more precise the percentage of dissatisfied. For instance in

chapter 2.3 it is shown, by research of Fiala, that the Dynamic thermal sensation (DTS) and the Predicted Mean Vote (PMV) are in general agreement with each other and that it is possible to calculate the Predicted Percentage of Dissatisfied (PPD) on the basis of the DTS. Appendix 13.2 focuses on a combination of new relationships with regard of predicted percentage of dissatisfied due to draught. With this combination of new relationships, programmed in a CFD-model, the scope of the here assembled model is much larger than the current draught model in NEN-EN-ISO-7730. In chapter 3.1 a new relationship is derived between the carbon dioxide concentration and the predicted percentage of dissatisfied due to the perceived air quality. This new relationship has a larger scope, with regard of metabolic rate, than the relationship displayed in NPR-CR-1752, which is only valid for a metabolic rate of 1,1 met. In chapter 3.2 a new relationship is derived between the freshness of the air and the predicted percentage of dissatisfied due to the perceived air quality. The model in chapter 4.2 shows new quantitative relationships between the equivalent background noise level and the predicted percentage of dissatisfied due to environmental noise (viz. road traffic, rail traffic, industry and air traffic). In chapter 5.2 relationships are shown between the predicted percentage of dissatisfied (PPD) and the Mean Thermal Sensation Vote of both elderly and non-elderly. It is advised to validate the models with new studies to verify if predicted effects are found in practice and whether the relationships can be improved or replaced by new ones.

Regarding the second part of the second question this PhD thesis shows how much the performance loss of people is influenced by discomfort. The models in chapter 2.2, 3, 4.1 and appendix 13.1 show quantitative relationships between the performance loss of people and thermal sensation or the perceived air quality or the speech intelligibility. In chapter 2.2 several performance loss equations as a function of thermal sensation, with different scopes, are implemented in one for this study assembled computer program, based on a thermophysiological human model. In the chapters 3.1 and 3.2 several equations, with different scopes, are shown in which the performance loss is a function of the predicted percentage of dissatisfied due to the perceived air quality. In chapter 4.1 a new quantitative relationship is shown between the performance loss and the speech intelligibility. Also, with regard to this point further validation is needed to verify if predicted effects are found in practice and whether the relationships can be improved or replaced by new ones.

Apart from answering the research questions the research in this PhD also has some shortcomings and asks for future research, especially in the area of validation of the models and international standardisation to make comparison of different studies possible. In table 7.1 an overview is shown on future research needs for the different areas.

Despite the shortcomings, this PhD shows that on the basis of literature data calculations can be made which can support decisions on indoor climate better than the now often used models.

Table 7.1. An overview of future research needed to model relationships between the indoor environment and perception and performance change.

<p><i>Thermal indoor climate</i></p> <ul style="list-style-type: none"> • Further research is needed how to modify the Stolwijk model with for instance: <ul style="list-style-type: none"> ○ individual characteristics, like is done in chapter 5.2 of this thesis with regard of the Gagge model (55), so the differences between subpopulations (e.g. young and old) can be assessed ○ performance loss models ○ a more accurate whole-body thermal sensation model, for the non-steady state situation,

<p>as is proposed in chapter 2.4</p> <ul style="list-style-type: none"> ○ a local thermal sensation model, equivalent to or more accurate than the thermal sensation and comfort model of Zhang et al. (126), (127) and with a larger scope (e.g. Metabolism ≥ 1 met). ● Standardize the classic and known thermal sensation experiments in the literature in future, on the basis of which reliable equations are to derive. In such a way that for each dynamic thermophysiological human model, equivalent to or more advanced than the Stolwijk model, the appropriate coefficients are to determine on the basis of the here proposed (TTS-) model in chapter 2.4
<p><i>Draught</i></p> <ul style="list-style-type: none"> ● To further investigate in how far the influence of the air direction, of which the sensation of draught could be a function of the metabolism, may not be fully taken into account in the formula of Griefahn et al. ● The (NEN-EN-)ISO 7730, pertaining to draught, should be reviewed and improved upon, for instance, in the manner mentioned in appendix 13.2
<p><i>Air quality</i></p> <ul style="list-style-type: none"> ● The extent to which the air velocity and air flow direction on facial height possibly affect the freshness of the air needs to be further examined
<p><i>Acoustics</i></p> <ul style="list-style-type: none"> ● Hongisto used the only few published studies that have investigated the effect of speech on cognitive performance with varying levels of speech intelligibility. Therefore more research is needed on the effect of speech intelligibility on task performance in order to improve the proposed model and encourage investments in acoustic improvements
<p><i>Environmental noise</i></p> <ul style="list-style-type: none"> ● Additional improvements and an extension of sources, for the new methodology in chapter 4.2, like the noise from restaurants, cafes and bars ● To implement the method and proposal for classification, in chapter 4.2, in the guideline CR-1752 and the standard EN-15251
<p><i>Ageing</i></p> <ul style="list-style-type: none"> ● To increase well-being for people with different ages the design criteria for the indoor environment should be further investigated and adapted because research show that: <ul style="list-style-type: none"> ○ older and younger people, even in the same environment, respond differently to the indoor environment ○ older people have a lower tolerance for uncomfortable situations than young people

8 Samenvatting

Ontwerpen op basis van welzijn tengevolge van het binnenmilieu is een kans voor ondernemingen omdat het mogelijkheden biedt voor comfort- en productiviteitsverbetering. Er is veel kennis in de wetenschappelijke literatuur aanwezig om verantwoorde beslissingen te nemen dan nu het geval is. Het probleem is echter dat de meest recente kennis niet beschikbaar is in bestaande modellen die door ontwerpers van (installaties in) gebouwen kunnen worden gebruikt ter voorspelling van een comfortabel en productief binnenmilieu. Dit proefschrift is een *capita selecta* van studies, elk met als doel het ontwikkelen van een betere methode ter voorspelling van de binnenmilieukwaliteit, gebaseerd op beschikbare kennis. Met de verbeterde modellen kan beter de perceptie, het percentage ontevreden of de prestatieverandering tengevolge van het binnenmilieu worden ingeschat.

De belangrijkste vragen van dit proefschrift zijn:

- Is verbetering van de huidige modellen mogelijk, opdat nauwkeuriger de relatie tussen de fysische aspecten van het binnenmilieu en de perceptie van die aspecten is te bepalen?
- Is verbetering van de huidige modellen mogelijk, opdat nauwkeuriger het percentage ontevreden en de prestatieverandering van mensen is vast te stellen?

Wat betreft de eerste vraag laat dit proefschrift zien dat het mogelijk is om bestaande modellen te verbeteren om nauwkeuriger te bepalen wat de invloed is van de fysische aspecten van het binnenmilieu op de perceptie van deze aspecten, en in het verlengde hiervan op comfort. In de hoofdstukken 2.3, 2.4, 3.2, 5.1 en 5.2 bijvoorbeeld worden, afhankelijk van het binnenmilieuaspect, nieuwe kwantitatieve relaties weergegeven en bestaande modellen verbeterd met als doel de invloed van de fysische omgeving op het comfortgevoel beter te kunnen beoordelen. Bijvoorbeeld door het toevoegen van kleding en temperatuursensatie, geschikt voor de beoordeling van dynamisch thermische condities (de zg. Dynamic thermal sensation (DTS) en de Transient Thermal Sensation (TTS)), aan het Stolwijk model (107), is het toepassingsgebied van het model groter geworden dan voorheen het geval was. Het model is hiermee geschikt voor de simulatie van de temperatuursensatie en kleding onder dynamisch thermische omstandigheden. Vóór deze aanpassingen, en de samenstelling van een computerprogramma, was het niet mogelijk om dynamisch thermische omstandigheden met kleding en temperatuursensatie te simuleren met het Stolwijk model.

Het model in hoofdstuk 3.2 toont de kwantitatieve relatie tussen de frisheid van de lucht, de temperatuur en de vochtigheid van de verontreinigde lucht veroorzaakt door de aanwezigheid van mensen. Het model komt overeen met de olf-decipoel methode van Fanger (64), die echter niet met de temperatuur en vochtigheid van de lucht rekening houdt. In de praktijk kunnen klachten over de onfrisse luchtkwaliteit niet altijd goed worden verklaard aan de hand van de evaluatiemethode, conform NPR-CR-1752 (44), gebaseerd op de gemeten koolstofdioxideconcentratie in de lucht. De evaluatiemethode gebaseerd op de frisheid van de lucht sluit echter beter aan op de klachten over de onfrisse luchtkwaliteit in de praktijk. Daarnaast is een kwantitatieve relatie afgeleid tussen de accumulatie van de vermoeidheid en het percentage ontevreden tengevolge van de waargenomen luchtkwaliteit. In hoofdstuk 5.1 wordt weergegeven op welke wijze de spraakverstaanbaarheid als functie van de leeftijd wordt berekend, op basis van de STI-methode (204).

In hoofdstuk 5.2, op basis van een voor dit onderzoek samengesteld computerprogramma, het onderzoek van Gonzalez (221) en het onderzoek Schellen et al. (197), wordt aangetoond dat de thermische gewaarwording van ouderen in het algemeen 0.5 PMV-eenheden lager is in vergelijking met jongeren, bij een gematigde temperatuurwisseling. Getoond wordt dat het mogelijk is het verschil in thermisch comfort, tussen ouderen en niet-ouderen, te kwantificeren, in relatie tot het Fangermodel.

Voor wat betreft het eerste deel in de tweede vraag laat dit proefschrift zien dat het mogelijk is om met verbetering van de huidige modellen beter het voorspelde percentage ontevreden enen is te bepalen. Bijvoorbeeld in hoofdstuk 2.3 wordt weergegeven dat, aan de hand van onderzoek door Fiala, de Dynamic thermal sensation (DTS) en de voorspelde gemiddelde uitspraak over het thermisch binnenklimaat (PMV) goed met elkaar overeenstemmen en dat het mogelijk is om het voorspelde percentage ontevreden enen te berekenen (PPD) op basis van de DTS. Appendix 13.1 richt zich op een combinatie van nieuwe kwantitatieve relaties ten aanzien van het voorspelde percentage ontevreden enen tengevolge van tocht. Met deze combinatie van relaties, geprogrammeerd in een CFD-model, is het toepassingsgebied van het hier samengestelde model veel groter dan het huidige tochtmodel, conform NEN-EN-ISO-7730. In hoofdstuk 3.1 een nieuwe relatie afgeleid tussen de kooldioxideconcentratie en het voorspelde percentage ontevreden enen tengevolge van de waargenomen luchtkwaliteit. Deze nieuwe relatie heeft een groter toepassingsgebied, met betrekking tot het metabolisme, dan de vergelijking zoals weergegeven in NPR-CR-1752, die alleen geldig is voor een metabolisme van 1,1 met. In hoofdstuk 3.2 is een nieuwe relatie afgeleid tussen de frisheid van de lucht en het voorspelde percentage ontevreden enen tengevolge van de waargenomen luchtkwaliteit. Het model in hoofdstuk 4.2 toont nieuwe kwantitatieve relaties tussen het equivalente achtergrondgeluivniveau en het voorspelde percentage ontevreden enen ten gevolge van het omgevingslawaai (nl. Wegverkeer, railverkeer, industrie en luchtverkeer). In hoofdstuk 5.2 worden kwantitatieve relaties weergegeven tussen het voorspelde percentage ontevreden enen en de gemiddelde thermische sensatie van zowel ouderen als niet-ouderen. Geadviseerd wordt om de modellen aan de hand van nieuwe studies te valideren en te controleren of voorspelde effecten ook in de praktijk worden gevonden en of de relaties kunnen worden verbeterd of vervangen door nieuwe.

Voor wat betreft het tweede deel in de tweede vraag laat dit proefschrift zien in hoeverre het prestatieverlies van mensen wordt beïnvloed door discomfort. De modellen in hoofdstuk 2.2, 3, 4.1 en appendix 13.1 tonen kwantitatieve relaties tussen het prestatieverlies van mensen en de temperatuursensatie of de waargenomen luchtkwaliteit of de spraakverstaanbaarheid. In hoofdstuk 2.2 zijn verschillende prestatieverliesvergelijkingen, als functie van de temperatuursensatie, met verschillende toepassingsgebieden, geïmplementeerd in een voor deze studie samengesteld computerprogramma, gebaseerd op een in de literatuur gevalideerd thermofysiologisch mensmodel. In de hoofdstukken 3.1 en 3.2 is een aantal vergelijkingen, met verschillende toepassingsgebieden, weergegeven waarbij het prestatieverlies een functie is van het voorspelde percentage ontevreden enen tengevolge van de waargenomen luchtkwaliteit. In hoofdstuk 4.1 wordt een nieuwe kwantitatieve relatie weergegeven tussen het prestatieverlies en de spraakverstaanbaarheid. Ook met betrekking tot dit punt is validatie gewenst, ter controle of voorspelde effecten zich ook in de praktijk voordoen en of de relaties kunnen worden verbeterd of vervangen door nieuwe.

Afgezien van het beantwoorden van de onderzoeksvragen heeft het onderzoek in dit proefschrift een aantal tekortkomingen die om nader onderzoek vragen, met name op het gebied van de validatie van de modellen en de internationale normalisatie om het vergelijken van verschillende studies mogelijk te maken. In tabel 8.1 wordt voor de verschillende aspecten een overzicht weergegeven van de behoefte aan nader onderzoek.

Ondanks de tekortkomingen, blijkt uit dit onderzoek dat op basis van literatuurgegevens berekeningen kunnen worden gemaakt waarmee ontwerpbeslissingen beter zijn te onderbouwen dan het geval is met de tegenwoordig vaak gebruikte modellen.

Tabel 8.1. Een overzicht van toekomstig noodzakelijk onderzoek ter modellering van de relatie tussen het binnenmilieu en de perceptie en de prestatieverandering.

<i>Thermisch binnenklimaat</i>
<ul style="list-style-type: none"> • Meer onderzoek is nodig om het Stolwijk model geschikt te maken voor bijvoorbeeld: <ul style="list-style-type: none"> ○ individuele kenmerken, zoals is gedaan in hoofdstuk 5.2 van dit proefschrift met betrekking tot het Gagge model (55), zodat de verschillen tussen subpopulaties (bv. jong en oud) kunnen worden vastgesteld ○ prestatieverliesmodellen ○ een nauwkeuriger thermisch sensatiemodel, voor het gehele lichaam, geschikt voor niet-stationaire situaties, zoals is voorgesteld in hoofdstuk 2.4 ○ een model voor de partiële thermische sensatie en comfort, equivalent aan of beter dan het thermische sensatie en comfortmodel van Zhang et al. (126), (127) en met een groter toepassingsgebied (bv. Metabolisme ≥ 1 met). • Het in de toekomst normaliseren van de klassieke en bekende thermische sensatiestudies in de literatuur op basis waarvan betrouwbare vergelijkingen zijn af te leiden. Zodat voor elk dynamisch thermofysiologisch mensmodel, equivalent aan of geavanceerder dan het Stolwijkmodel, de juiste coëfficiënten zijn vast te stellen op basis van het voorgestelde (TTS-model) in hoofdstuk 2.4
<i>Tocht</i>
<ul style="list-style-type: none"> • Nader onderzoeken in hoeverre de invloed van de stromingsrichting, waarbij de hierdoor veroorzaakte tochtsensatie een functie van het metabolisme kan zijn, wellicht niet volledig is verdisconteerd in de formule van Griefahn et al. • De (NEN-EN-)ISO 7730 dient, voor wat betreft het tochtaspect, te worden aangepast en verbeterd, bijvoorbeeld op de wijze zoals beschreven in appendix 13.2
<i>Luchtkwaliteit</i>
<ul style="list-style-type: none"> • De mate waarin de luchtsnelheid en de stromingsrichting op gezichtshoogte mogelijk van invloed kan zijn op de frisheid van de lucht dient nader te worden onderzocht
<i>Akoestiek</i>
<ul style="list-style-type: none"> • Hongisto gebruikte de weinige studies, waarbij het effect is onderzocht van spraak op de cognitieve prestatie bij verschillende niveau's van spraakverstaanbaarheid. Om die reden is aanvullend onderzoek nodig naar het effect van spraakverstaanbaarheid op de prestatie, om het hier voorgestelde model te verbeteren en om investeringen in akoestische verbeteringen aan te moedigen
<i>Omgevingslawaai</i>
<ul style="list-style-type: none"> • Verbeteringen en een uitbreiding van geluidbronnen, zoals horecalawaai, in de nieuwe methodology in hoofdstuk 4.2 • De methode en de voorgestelde classificatie, in hoofdstuk 4.2, implementeren in de richtlijn NPR-CR-1752 alsmede de norm EN-15251

Ouderdom

- Om het welzijn van personen, met verschillende leeftijden, te vergroten dienen de ontwerpcriteria voor het binnenmilieu nader te worden onderzocht en aangepast omdat onderzoek uitwijst dat:
 - oude en jonge mensen, zelfs in dezelfde omgeving, verschillend reageren op het binnenmilieu
 - oude mensen over een lagere tolerantie voor oncomfortable situaties beschikken dan jonge mensen

Paul Roelofsen is born in Amsterdam, the Netherlands, on the 9th of April in 1958 as the son of Gerda de Lange en Carel Roelofsen. He is raised in Helmond, a town in the south-eastern part of the Netherlands. He followed his secondary education at the National Athenaeum in Helmond, from which he graduated in 1976. Following this, he studied Architecture, Urban Planning and Housing at the Eindhoven University of Technology specialising in the Physical Aspects of the Built Environment from 1976 until 1983. After graduation, he continued his education through postgraduate studies in Mechanical Engineering (1986), Environment & Noise (1997), Facility Management (2000) and Quality Management (2004).

Paul is a visiting lecturer and occupies various supplementary functions within both his working and tutoring activities. He is also active with various contact groups, related to his expertise in building constructional techniques, and performs several functions for, and within, these groups. The IFMA Award of Excellence for outstanding contributions to the Facility Management profession was presented to Paul in the USA in 2004 as well as an Award for Building Services Innovation in the Netherlands in 2007. In 2012 he started his PhD at the Faculty Industrial Design Engineering, section Applied Ergonomics and Design, of the Delft University of Technology in the Netherlands. Paul was a senior consultant at Grontmij (part of Sweco) at the time this study was executed. At the moment Paul is a senior consultant at BAM Techniek – Energy Systems and lives with his two children, Marjolein en Gijs, in Amersfoort in the Netherlands.

10 Publications

The following published papers are related to this thesis

- Roelofs P, Koolmonoxide en tabaksrook, TVVL-Magazine 1998; May: 18-20.
- Roelofs P, The design of the workplace as a strategy for productivity enhancement 2001, Proceedings 7th REHVA World Congress Clima 2000/Napoli 2001.
- Roelofs P, The impact of office environments on employee performance, Journal of Facilities Management 2002; 1(3): 247-264.
- Roelofs P, The impact of air quality on employee performance – Carbon dioxide as a performance indicator for the perceived air quality, Facility Management Journal 2003, September/October: 42-48.
- Roelofs P, A consulting engineer point of view, WS4 “Indoor Environmental Quality and Productivity: Challenges for Future Work”, Clima 2007 “WellBeing Indoors”, 10-14 June 2007, Helsinki, Finland
- Roelofs P, ‘t Hooft E, Healthy investments in HVAC systems, Journal of Facilities Management 2008; 6(1): 69-79.
- Roelofs P, Performance loss in open plan offices due to noise by speech, Journal of Facilities Management 2008; 6(3): 202-211.
- Roelofs P, Evaluation of draught in surgical operating theatres: proposed revision to (NEN)-EN-ISO-7730, Journal of Facilities Management 2011; 9(1): 64-70.
- Roelofs P. Nieuw Bouwbesluit gaat voorbij aan gezond binnenmilieu, TVVL-Magazine. 2012; January: 24-25
- Roelofs P, Evaluation of environmental noise based upon the percentage of dissatisfied, Journal of Facilities Management 2012, 10(2): 133-139.
- Roelofs P, Healthy ageing and the built environment, Intelligent Buildings International 2014; 6(1): 3-10.
- Roelofs P, Healthy ageing – Design criteria for the indoor environment for vital elderly, Intelligent Buildings International 2014; 6(1): 11-15
- Roelofs P., Interior environments for different ages, Proceedings of the 5th International Conference on Applied Human Factors and Ergonomics AHFE 2014, Kraków, Poland, 19-23 July 2014
- Roelofs P, Healthy ageing: differences between elderly and non-elderly in thermal sensation and dissatisfied, Intelligent Buildings International 2015; DOI: 10.1080/17508975.2015.1063474:1-15.
- Roelofs P, A computer model for the assessment of employee performance loss as a function of thermal discomfort or degree of heat stress, Intelligent Buildings International 2015; DOI 10.1080/17508975.2015.1011071: 1-20.
- Roelofs P, Vink P, Improvement of the Stolwijk model with regard of clothing, thermal sensation and skin temperature 2016, Work, 54(4): 1009-1024.

11 Acknowledgement

This work could not have been completed without the support of colleagues, friends and family members; some of them I would like to mention in particular.

Grontmij Nederland B.V. supported and funded the study and gave me the opportunity to fulfill a long cherished wish. For which I am grateful. I am especially indebted to Robert Phillippi, Peter Matlung, Barry van Sloten, Herman Snoek and Hubert Habib for their contribution in supporting the project.

Special thanks goes to Peter Matlung for his encouragements and support during my PhD study.

Professor Vorenkamp with his inspiring lessons and attention to his students laid an important fundament for my further scientific development.

Professor dr. Vink, my promotor, who offered me the opportunity to do this project and supported me mentally. His starting point is the centrality of the human being rather than the technique. He has managed to put together an excellent research team, with a strong social bond. In his way of leadership he showed me a lot of freedom. That motivated me enormous. A true professor. Thank you for achieving the right balance between independence, control and challenge.

The support of Egbert 't Hooft is gratefully acknowledged. In all the years as a colleague he was my sounding board with whom I was able to discuss the results of my work. Thank you for the reviewing and the editing of my reports and articles.

Steve Taylor who helped me with the translation of several articles.

Dr. Conne Bazley who helped me with the editing of several articles.

During my consultancy work my life has been enriched with new international friends. I met professor dr. Derek Clements-Croome at the Clima 2000, 7th World Congress in Naples, as one of the key-note speakers. Since then we kept in touch and he motivated me with his attention and support.

Professor dr. Michael Pitt who recognized immediately the importance of the relationship between the physical environment and the human performance within the facility management field of study and helped me with carry out my ideas to facility managers all over the world.

Dr. Larry Berglund I got to know through his research. Larry has a lot of research experience and has a lot of unique issues investigated. His studies, I read, fascinated me every time. Fortunately, Larry was always willing to answer my questions and willing to help me with my research, when I asked for it. Thanks for that.

One of my best friends, Hans Bloemen, who, as vice-president Facility Management of AHOLD at that time, and like me a visiting lecturer at FMH, gave me the faith I needed to start the research. Thank you for the inspiring discussions till late in the morning along with all the fine whisky's and wines from your basement.

Dr. Atze Boerstra and dr. Iris Bakker who as first suggested me to turn my plans, about the relationship between indoor environment, perception and performance change, into a PhD project.

My dear friends and family members, I thank you very much for your hospitality, support and interest and provide me distraction next to my thesis work.

My two children, Marjolein en Gijs, they motivated me to continue in a time when our domestic life changed dramatically. You have shown to be a crack unit together. I love you both so much.

My parents, who always followed my activities with lots of love, care and attention. This thesis is emerged from the spiritual luggage I have inherited from them and the opportunities they offered me in life. Mom, I hope you are able to be a witness of it all somehow because you especially have earned this.

Finally, I dedicate this thesis, firstly, with love, to Jessica, who means a lot to me. Dear Jessica, the thesis work is done. This project is finished. Thanks for your patience, support and unconditional love. Let's go to the next new challenge. Let's enjoy our road through life together, with the children around us. I wish that joy lasts a life time.

Thank you all!

1. BOMA. Office Tenant Moves and Changes. Building Owners and Managers Association International. 1988.
2. Leyten J, Kurvers S. Gezonde kantoren nog niet vanzelfsprekend. Facility Management Magazine. 2000 February;: p. 14-20.
3. Clements-Croome D. Creating the Productive Workplace London: Taylor & Francis Ltd.; 2006.
4. Jones Lang LaSalle. JLL Occupier Special Duurzaamheid 2013. Amsterdam;: 2013.
5. Healthy Buildings Europe 2015. [Online].; 2015. Available from: <http://hb2015-europe.org>.
6. Clements-Croome D. Creative and productive workplaces: a review. Intelligent Buildings International. 2015 mei 19; <http://dx.doi.org/10.1080/17508975.2015.1019698>: p. 1-20.
7. Riratanaphong C. Performance measurement of workplace change in two cultural contexts. Thesis. Delft: Delft University of Technology , Faculty of Architecture and the Built Environment, Real Estate and Housing Department; 2014. Report No.: ISBN 978-94-6186-265-5.
8. Bluysen PM. The Healthy Indoor Environment: Taylor & Francis Ltd; 2013.
9. Vink P, Koningsveld EAP, Molenbroek JF. Positive outcomes of participatory ergonomics in terms greater comfort and higher productivity. Applied Ergonomics. 2006; 37: p. 537-546.
10. in 't Veld J. Analyse van organisatieproblemen - Een toepassing van denken in systemen en processen. zesde herziene druk, vierde oplage ed. The Netherlands: Stenfert Kroese/Educatieve Partners; 1996.
11. Bluysen PM. Understanding the indoor environment. Inaugural speech. Delft: Delft University of Technology, Faculty of Architecture; 2013.
12. Watson JB. Behaviorism (revised edition) Chicago: University of Chicago Press; 1930.
13. Woodworth RS. Dynamics of behavior Oxford: Henry Holt & Co., Inc.; 1958.
14. Goi MT, Kalidas V, Zeeshan M. Personality as a Moderator of SOR Model. Review of Integrated Business and Economics Research. 2014; 3(2): p. ISSN:2304-1013 (Online); 2304-1269 (CDROM).
15. Changa HJ, Eckman M, Yan RN. Application of the stimulus-Organism-Response model to the retail environment: the role of hedonic motivation in impulse buying behaviour. The International Review of Retail, Distribution and Consumer Research. 2011; 21(3): p. 233-249.
16. He L, Chen L, Hoyle C, Yannou B. Choice modeling for Usage Context-Based Design. Journal of Mechanical Design. 2012; 134(3): p. (11 pages): DOI:10.1115/1.4005860.
17. Roel MKW. Wettelijke eisen en Rgd-richtlijnen voor bouwfysica. Den Haag;: 1994.
18. Miskovich RS, Byerly JV, Miller SW. Adaptation of 25-node human thermal model for use in Sierra Nevada Corporation's Dream Chaser® System-level Thermal Desktop Model. In Thermal & Fluids Analysis Workshop (TFAWS) 2014 Proceedings; 2014; NASA, Glenn Research Center, Cleveland. p. 1-16.
19. Fiala D, Lomas KJ, Stohrer M. First principles modelling of thermal sensation responses in steady state and transient boundary conditions. ASHRAE Transactions. 2003; 109(1): p. 179-186.
20. Toftum J, Jørgensen AS, Fanger PO. Upper limits of air humidity for preventing warm respiratory discomfort. Energy and Buildings. 1998; 28: p. 15-23.
21. Fanger PO. Introduction of the of- and the decipol-unit to quantify air pollution perceived by

- humans indoors and outdoors. *Energy and Buildings*. 1988; 12: p. 1-6.
22. NPR-CR-1752. Ventilation for buildings - Design criteria for the indoor environment. CEN-report. Delft; 1999 January.
 23. NEN-EN-15251. Indoor environmental input parameters for design and assessment of energy performance of buildings addressing indoor air quality, thermal environment, lighting and acoustics. Delft; 2007.
 24. ABSIC / CMU. Health, Productivity and the Triple Bottom Line. [Online].; 2007 [cited 2016 april 14]. Available from: http://www.cmu.edu/iwess/workshops/absic_dec_2007/BIDS%20ABSIC_FINAL%202007.pdf.
 25. Boerstra AC, Dijken F. www.kantoorvolenergie.nl. [Online]. Den Haag; 2015 [cited 2016 April 19]. Available from: <http://www.kantoorvolenergie.nl/wp-content/uploads/downloads/2015/10/BBA-Rapport-Kentallen-binnenmilieu-productiviteit-151015.pdf>.
 26. Preller L, Zweers T, Boleij JSM, Brunekreef B. Gezondheidsklachten en klachten over het binnenklimaat in kantoorgebouwen Den Haag: SZW-DGA; 1990.
 27. Clements-Croome D, Baizhan L. Assessment of the Influence of Indoor Environment on te Job Stress and Productivity of Occupants in Offices. In *Healthy Buildings / IAQ '97*; 1997. p. 495-500.
 28. Rolloos M. *Praktijkboek Gezonde Gebouwen: Een gezond binnenmilieu betaald zichzelf terug*; 1997.
 29. Lorsch HG, Abdou OA. The Impact of the Building Indoor Environment on Occupant Productivity, Part 2: Effects of Temperature. *ASHRAE Transactions*. 1994; 100(2): p. 895-901.
 30. Clements-Croome D. *Naturally Ventilated Buildings* London: E & FN Spon; 1997.
 31. Wargocki P, Seppanen O, Andersson J, Boerstra A, Clements-Croome D, Fitzner K, et al. Guidebook No. 6. "Indoor Climate and Productivity in Offices". REHVA; 2006.
 32. Clements-Croome D, Kaluarachchi Y. An assessment of the Influence of the Indoor Environment on the Productivity of Occupants in Offices. *Design, Construction and Operation of Healthy Buildings*. 2000;: p. 67-81.
 33. Witterseh T. Environmental perception, SBS symptoms and the performance of office work under Combined Exposures to temperature, Noise and Air Pollution. Thesis, MEK-I-Pd.D.01-01. Lyngby: Technical University of Denmark, International Centre for Indoor Environment and Energy, Department of Mechanical Engineering; 2001. Report No.: ISBN: 87-7475-201-4.
 34. Balazova I, Clausen G, Rindel JH, Poulsen T, Wyon DP. Open-plan office environments: A laboratory experiment to examine the effect of office noise and temperature on human perception, comfort and office work performance. *Proceedings of Indoor Air*. 2008 August 17-28.
 35. Haneda M, Tanabe Si, Nishihara N, Nakamura S. The combined effects of thermal environment and ventilation rate on productivity. In *Indoor Air 2008 - Paper ID:108*; 2008; Copenhagen.
 36. Shek KW, Chan WT. Combined comfort model of thermal comfort and air quality on buses in Hong Kong. *Science of the total environment*. 2008; 389: p. 277-282.
 37. Pellerin N, Candas V. Combined effects of temperature and noise on human discomfort. *Physiology & Behavior*. 2003; 78: p. 99-106.
 38. Liebl A, Haller J, Jodicke B, Baumgartner H, Schlittmeier S, Helbruck J. Combined effects of acoustic and visual distratction on cognitive performance and well-being. *Applied Ergonomics*. 2012; 43: p. 424-434.
 39. Wyon DP. The Effects of Indoor Climate on Productivity and Performance. *VVS & Energi*. 1986; 3: p. 59-65.
 40. Wargocki P, Wyon DP, Baik YK, Clausen G, Fanger PO. Perceived Air Quality, Sick Building Syndrome (SBS) Symptoms and Productivity in an Office with Two Different Pollution Loads. *Indoor Air*. 1999 September; 9(3): p. 165-179.
 41. Fanger PO. Toekomstvisie van een Deen op de klimaattechniek. *TVVL-Magazine*. 2000 January;: p. 32-33.
 42. Hongisto V. A model predicting the effect of speech of varying intelligibility on work performance. *Indoor Air*. 2005; 15(6): p. 458-468.
 43. Burge S, Hedge A, Wilson S, Bass JH, Robertson A. Sick Building Syndrome: a study of 4373

- office workers. *Annals of Occupational Hygiene*. 1987; 31: p. 493-504.
44. Bazley CM. *Beyond Comfort in Built Environments*. Thesis. Delft: Delft University of Technology, Industrial Design Engineering; 2015. Report No.: ISBN 978-0-979496308-7.
 45. Boerstra AC, Loomans MGLC, Hensen JLM. Personal control over indoor climate and productivity. In *Proceedings of Indoor Air 2014*; 2014; Hongkong. p. 1-8.
 46. Roelofsen P. The design of the workplace as a strategy for productivity enhancement. In 7th REHVA World Congress, Clima 2000/Napoli 2001, 15-18 september; 2001; Napoli (I): REHVA.
 47. Mohamed S, Korb S. Thermal environment effects on construction workers' productivity. *Work Study*. 2002; 51(6): p. 297-302.
 48. Mohamed S, Korb S. Thermal environment effects on construction workers' productivity: some evidence from Thailand. *Building and Environment*. 2003; 38: p. 339-345.
 49. Kosonen R, Tan F. Assessment of productivity loss in air-conditioned buildings using PMV-index. *Energy and Buildings*. 2004; 36: p. 987-993.
 50. Jensen KL, Toftum J, Friis-Hansen P. A bayesian network approach to the evaluation of building design and its consequences for employee performance and operational costs. *Building and Environment*. 2009; 44: p. 456-462.
 51. Lan L, Wargocki P, Lian Z. Quantitative measurement of productivity loss due to thermal discomfort. *Energy and Buildings*. 2011; 43: p. 1057-1062.
 52. Zhao J, Zhu N, Lu S. Productivity model in hot and humid environment based on heat tolerance time analysis. *Building and Environment*. 2009; 44: p. 2204-2207.
 53. Jacobs P, Van Dijken F, Boerstra A. Prestatie-eisen ventilatie in klaslokalen. *VV+*. 2007; p. 490-493.
 54. Berglund LG, Gonzalez RR, Gagge AP. Predicting human performance decrement from thermal discomfort and ET. In *The fifth international conference on indoor air quality and climate*, July 29 - August 3; 1990; Toronto. p. 215-220.
 55. Gagge AP, Fobelets AP, Berglund LG. A standard predictive index of human response to the thermal environment. *ASHRAE Transactions*. 1986; Vol. 92, part2.
 56. NEN-EN-ISO-7730. Ergonomics of the thermal environment - Analytical determination and interpretation of thermal comfort using calculation of the PMV and PPD indices and local thermal comfort criteria (ISO 7730:2005.IDT). 2005..
 57. De Gids WF, Oel CJ, Phaff JC, Kalkman A. Het effect van ventilatie op de cognitieve prestaties van leerlingen op een basisschool. TNO-2006-D-1078/B. Delft: TNO , Bouw en Ondergrond; 2007.
 58. Wargocki P, Wyon DP, Matysiak B, Irgens S. The effects of classroom air temperature and outdoor supply rate on the performance of school work by children. In *Indoor Air: Proceedings of the 10th international conference on indoor air quality and climate*; 2005; Beijing. p. 368-372.
 59. Shaughnessy RJ, Havinen-Shaughnessy U, Nevalainen A, Moschandreas D. A preliminary study on the association between ventilation rates in classrooms and student performance. *Indoor Air*. 2006; 6(6): p. 465-468.
 60. Haapakangas A, Haka M, Keskinen E, Hongisto V. Effect of speech intelligibility on task performance - an experimental laboratory study. In *9th International Congress on Noise as a Public Health Problem (ICBEN)* ; 2008; Foxwoods, CT, USA.
 61. Haka M, Haapakangas A, Keranen J, Hakala J, Keskinen E, Hongisto V. Performance effects and subjective disturbance of speech in acoustically different office types – a laboratory experiment. *Indoor Air*. 2009; 19: p. 454-467.
 62. Pernot CEE, Euser P. *Voorstudie over de behaaglijkheidscriteria in gebouwen in de zomersituatie*. Eindhoven: TH-Eindhoven, Bouwkunde; 1981. Report No.: 000.335.
 63. Sullivan CD, Gorton RL. A method of calculation of WBGT from environmental factors. *ASHRAE Transactions*. 1976; 82(2): p. 279-292.
 64. Doherty T, Arens EA. Evaluation of the physiological bases of thermal comfort models. *ASHRAE transactions*. 1988;(Vol. 94, Part 1): p. 1371-1385.
 65. Takada S, Sakiyama T, Matsushita T. Validity of the two-node model for predicting steady-state

- skin temperature. *Building and Environment*. 2011; 46: p. 597-604.
66. Berglund LG, Yokota M, Potter AW. Thermophysiological responses of sailors in a disabled submarine with interior cabin temperature and humidity slowly rising as predicted by computer simulation techniques. Technical Report. Natick, Massachusetts: Biophysics and Biomedical Modeling Division, U.S. Army Research Institute of Environmental Medicine; 2013. Report No.: T13-06.
 67. Wölki D, Bruntjen MA, Schmidt C, Van Treeck C. A dynamic index for transient thermal comfortprediction. In Fifth German-Austrian IBPSA Conference; 2014; Aachen. p. 38-47.
 68. Ooka R, Minami Y, Sakoi T, Tsuzuki K, Rijal HB. Improvement of sweating model in 2-Node Model and its application to thermal. *Building and Environment*. 2010; 45: p. 1565–1573.
 69. Seppanen O, Fisk WJ, Faulkner J. Control of temperature for health and productivity in offices. Espoo, Finland: Helsinki University of Technology, Institute of Heating Ventilation and Air Conditioning; 2004. Report No.: LBNL-55448.
 70. Tawada T, Ikaga T, Murakami S, Uchida S, Ueda H. The total effect on performance and energy consumption caused by office's thermal environment. *Journal of Architecture, Planning, Environment and Energy*. 2010;(648): p. 213-219.
 71. Zhang H, Arens E, Pasut W. Air temperature thresholds for indoor comfort and perceived air quality. *Building Research & Information*. 2011; 39(2): p. 134-144.
 72. Loveday DL, Hanby VI, Woodward WB. A software toolfor relating the comfort and productivity of occupants in commercial buildings. CIBSE National Conference. 1995;; p. 69-75.
 73. Boyce PR, Griffiths ID. Performance and thermal comfort. *Ergonomics*. 1971; 14(4): p. 457-468.
 74. Wyon DP, Andersen MD, Lundqvist GR. The effects of moderate Heat Stress on mental performance. *Scand. J. Work Environ. and Health*. 1979; 5: p. 352-361.
 75. Hettinger T. Klima und Luft am Arbeitsplatz, Messtechnisches Taschenbuch für den Betriebspraktiker - Einfluss des Klimas auf den Menschen Eissing G, editor. Köln: Institut für Angewandte Arbeitswissenschaft, Wirtschaftsverlag Bachem; 1986.
 76. Wyatt TJ. The DSCH approach to more natural indoor climates. In Proc. Clima 2000 Conference, paper 69; 1993; London.
 77. Allen MA, Fischer GJ. Ambient temperature effects on paired associate learning. *Ergonomics*. 1978; 21(2): p. 95-101.
 78. Lorsch HG, Abdou OA. The Impact of the Building Indoor Environment on Occupant Productivity, Part 3: Effects of Indoor Air Quality. *ASHRAE Transactions*. 1994; 100(2): p. 902-913.
 79. Bilhaif A. The influence of high temperatures on the productivity of construction workers. (Unpublished) PhD Thesis. Reading: University of Reading; 1990.
 80. Koehn E, Brown G. Climatic effects on construction. *Journal of Construction Engineering and Management*. 1985; 111(2): p. 129-137.
 81. NECA. The effect of temperature on productivity. Washington D.C.; 1974.
 82. Thomas HR, Sakarcan AS. Forecasting labor productivity using factor model. *Journal of Construction Engineering and Management*. 1994; 120(1): p. 228-239.
 83. Thomas HR, Yiakoumis I. Analysis of the combined effects of learning and weather on construction productivity. In Paper presented at the 5th International Symposium on the Organization and Management of Construction; 1987; London.
 84. Fanger PO. *Thermal Comfort - Analysis and applications in environmental engineering*. 2nd ed.: McGraw-Hill Book Company; 1972.
 85. Wyon DP, Fanger PO, Olesen BW, Pedersen CJK. The mental performanceof subjects clothed for comfort at two different air temperatures. *Ergonomics*. 1975; 18: p. 358-374.
 86. Wyon DP. Individual microclimate control: Required range, probable benefits and current feasibility. In Proceedings of 7th International Conference on Indoor Air Quality and Climate. Indoor Air 1996; 1996; Nagoya, Japan: Institute of Public Health. p. 27-36.
 87. Leyten J, Kurvers SR, Raue AK. Temperature, thermal sensation and workers' performance in air-conditioned and free-running environments. *Architectural Science Review*. 2012; 56(1): p. 14-21.

88. NEMA. Lighting and human performance, a review. Washington D.C.; 1989.
89. Bruel & Kjaer. Technical Review, no. 2, "Heat Stress". Technical Review. Naerum.; 1985. Report No.: 2.
90. NEN-ISO 7243. Hot environments - Estimation of the heat stress on working man, based on the WBGT-index (Wet Bulb Globe Temperature). Delft.; 1989.
91. NEN-EN-ISO 7933. Ergonomics of the thermal environment - Analytical determination and interpretation of heat strain using calculation of the predicted heat strain (ISO 7933: 2004). Delft.; 2004.
92. Bernard TE, Hanna WM. Environmental effects on WBGT and HSI using a computer simulation. *International Journal of Industrial Ergonomics*. 1988; 3: p. 103-113.
93. Brief RS, Confer RG. Comparison of heat stress indices. *American Industrial Hygiene Association Journal*. 2010; 32(1): p. 11-16.
94. Azer NZ, Hsu S. OSHA Heat Stress standards and the WBGT index. *ASHRAE Transactions*. 1977; 83(2): p. 30-40.
95. Mackworth NH. Effects of heat on wireless operators hearing and recording morse code messages. *British Journal of Industrial Medicine*. 1946; 3: p. 143-158.
96. Roelofsen P. The impact of office environments on employee performance. *Journal of Facilities Management*. 2002; Vol. 1, no. 3: p. 247-264.
97. Roelofsen P, 't Hooft E. Healthy investments in HVAC systems. *Journal of Facilities Management*. 2008; Vol. 6, no. 1: p. 69-79.
98. Stolwijk JAJ, Hardy JD. Temperature regulation in man - A theoretical study. *Pflügers Archiv*. 1966;(291): p. 129-162.
99. Katic K, Zeiler W, Boxem G. Thermophysiological models: a first comparison. In *BauSIM 2014 - Fifth German-Austrian IBPSA Conference*; 2014; Aachen. p. 595-602.
100. Katic K, Rongling L, Zeiler W. Thermophysiological models and their applications: A review. *Building and Environment*. 2016; 106: p. 286-300.
101. Gordon RG. The response of a human temperature regulatory system model in the cold. PhD thesis. Santa Barbara, CA: University of California; 1974.
102. Zhou X, Zhang H, Lian Z, Lan L. Predict thermal sensations of chinese people using a thermophysiological and comfort model. In *Preprint, Proceedings of Indoor Air 2014*; 2014: Center for the Built Environment UC Berkeley. p. 1-8.
103. Munir A, Takada S, Matsushita T. Re-evaluation of Stolwijk's 25-node human thermal model under thermal-transient conditions: Prediction of skin temperature in low-activity conditions. *Building and Environment*. 2009; 44(9): p. 1777-1787.
104. Munir A, Takada S, Matshushita T, Kubo H. Prediction of human thermophysiological responses during shower bathing. *International Journal of Biometeorology*. 2010 March; 54(2): p. 165-178.
105. *Ingegneria medica Universita' di Tor Vergata Roma. Termofluidodinamica dei sistemi biologici*. [Online].; 2016 [cited 2016 February 15. Available from: <http://ingegneriamedica.altervista.org/doc/termoregolazione.pdf>.
106. Gagge AP, Hardy JD, Stolwijk JAJ. *Physiological and Behavioral temperature regulation* Gagge AP, Hardy JD, Stolwijk JAJ, editors. USA: Thomas Publishers; 1970.
107. Stolwijk JAJ. A mathematical model of physiological temperature regulation in man. Washington D.C.; 1971. Report No.: NASA CR-1855.
108. Stolwijk JAJ, Hardy JD. Control of body temperature, in *Handbook of Physiology* Bethesda, Maryland: American Physiological Society; 1977.
109. Konz S, Hwang C, Dhiman B, Duncan J, Masud A. An experimental validation of mathematical simulation of human thermoregulation. *Comput. Biol. Med.* 1977; Vol. 7: p. 71-82.
110. Haslam RA, Parsons KC. A comparison of models for predicting human response to hot and cold environments. *Ergonomics*. 1987;(11): p. 1599-1614; DOI:10.1080/00140138708966050.
111. Woerlee M. SETMA - A mathematical model of the human thermoregulation for predicting thermal comfort under various environmental conditions. BGD-report 305/38. The Hague: Medical Department , section Work Physiology; 1982.

112. Fiala D. Dynamic simulation of human transfer and thermal comfort. Thesis. Leicester: Montfort University Leicester/Fh Stuttgart-Hochschule fur Technik, Institute of Energy and Sustainable Development/Jospeh-von-Egle Institut fur angewandte Forschung ; 1998.
113. Schellen L, Loomans MGLC, Kingma BRM, de Wit MH, Frijns AJH, van Marken Lichtenbelt WD. The use of a thermophysiological model in the built environment to predict thermal sensation coupling with the indoor environment and thermal sensation. *Building and Environment*. 2013; 59: p. 10-22.
114. Schellen L. De invloed van een dynamisch binnenklimaat op thermisch comfort en productiviteit - Een onderzoek met proefpersonen onder laboratoriumcondities. Afstudeerproject. Eindhoven: Technische Universiteit, Bouwkunde; 2007. Report No.: 0532632.
115. Gagge AP, Stolwijk JAJ, Hardy JD. Comfort and thermal sensations and associated physiological responses at various ambient temperatures. *Environmental Research*. 1967 January 10;(1): p. 1-20.
116. Shitzer A, Rasmussen EB, Fanger PO. Human responses during recovery from heat stress with relation to comfort. *Ergonomics*. 2007 May 1; 21(1): p. 21-34.
117. Berglund LG, Gonzalez RG. Application of acceptable temperature drifts to built environments as a mode of energy conservation. *ASHRAE Journal*. 1977; 19(12): p. 110-121.
118. Nishi Y, Gonzalez R, Nevins RG, Gagge AP. Field measurement of clothing thermal insulation. *ASHRAE Transactions*. 1976; 82(2): p. 248-259.
119. Nevins RG, Gonzalez RR, Nishi Y, Gagge AP. Effect of changes in ambient temperature and level of humidity on comfort and thermal sensations. *ASHRAE Transactions*. 1975; Vol 81(2): p. 169-182.
120. Takada S, Matsumoto S, Matsushita T. Prediction of whole-body thermal sensation in the non-steady state based on skin temperatures. *Building and Environment*. 2013;(68): p. 123-133.
121. Gagge AP, Stolwijk JAJ, Saltin B. Comfort and thermal sensations and associated physiological responses during exercise at various ambient temperatures. *Environmental Research*. 1969; 2: p. 209-229.
122. Xiuyuan Du , Baizhan Li , Hong Liu , Dong Yang , Wei Yu , Jianke Liao , et al. The response of human thermal sensation and its prediction to temperature step-change (cool-neutral-cool). *Plos One*. 2014; Vol. 9(Issue 8): p. 1-10.
123. Hong Liu , Jianke Liao , Dong Yang , Xiuyuan Du , Pengchao Hu , Yu Yang , et al. The response of human thermal perception and skin temperature to step-change transient thermal environments. *Building and Environment*. 2014; 73: p. 232-238.
124. Zhu Y, Quyang Q, Cao B, Zhou X, Yu J. Dynamic thermal environment and thermal comfort. *Indoor Air*. 2016; 26: p. 125-137.
125. Wang X. Thermal comfort and sensation under transient conditions. Doctoral thesis. Stockholm: Thr Royal Institute of Technology, Department of Energy Technology, Division of Heating and Ventilation; 2003. Report No.: S-100 44.
126. Jones BW. Capabilities and limitations of thermal models for use in thermal comfort models. *Energy and Buildings*. 2002; 34: p. 653-659.
127. Zhang H, Arens E, Huizenga C. Thermal sensation and comfort models for non-uniform and transient environments: part I: local sensation of individual body parts. *Building and Environment*. 2010; 45: p. 380-388.
128. Zhang H, Arens E, Huizenga C. Thermal sensation and comfort models for non-uniform and transient environments: part II: local comfort of individual body parts. *Building and Environment*. 2010; 45: p. 389-398.
129. Zhang H, Arens E, Huizenga C. Thermal sensation and comfort models for non-uniform and transient environments: part III: whole-body sensation and comfort. *Building and Environment*. 2010; 45: p. 399-410.
130. ISSO-researchrapport 5. Ontwerpbinnencondities en thermische behaaglijkheid in gebouwen. Rotterdam: ISSO; 1990.
131. Goto J, Toftum J, de Dear R, Fanger PO. Thermal sensation and thermophysiological responses to metabolic step-changes. *Int. J. Biometeorol*. 2006; 50: p. 323-332.

132. Fiala D, Lomas KJ. The Dynamic Effect of Adaptive Human Responses in the Sensation of Thermal Comfort. In *Moving Thermal Comfort Standards into the 21th Century*, Conference Proc.; 2001; Windsor, UK. p. 147-157.
133. Bluysen PM. Air quality evaluated by a trained panel. PhD-Thesis. Lyngby: Technical University of Denmark, Laboratory of Heating and Air Conditioning; 1990.
134. Pejtersen J, Leif O, Skar S, Clausen G, Fanger PO. A simple method to determine the olf load in a building. In *The fifth International Conference on Indoor Air Quality and Climate*; 1990; Toronto: Canada.
135. Rasmussen C. The influence of human activity on ventilation requirements for the control of body odour. In *Clima 2000*; 1985; Copenhagen: REHVA. p. 357-362.
136. Zhang X, P. Wargocki, Lian Z, Thyregod C. Effects of Exposure to Carbon Dioxide and Bioeffluents on Perceived Air Quality, Self-assessed Acute Health Symptoms and Cognitive Performance. *Indoor Air*. 2016 January 30.
137. Lauridsen J, Muhaxheri M, Clausen GH, al e. Ventilation and background odour in offices. In *Indoor Air'87*, Proceedings of the 4th International Conference on Indoor Air Quality and Climate; 1987; Berlin. p. 640-644.
138. Berglund LS, Cain WS. Perceived air quality and the thermal environment. In *Proceedings of the ASHRAE/SOEH Conference I.A.Q '89 - The Human Equation: Health and Comfort*; 1989.
139. Fang L, Clausen G, Fanger PO. Impact of temperature and humidity on perception of indoor air quality during immediate and longer whole-body exposures. *Indoor Air*. 1998; 8: p. 80-90.
140. Knudsen HN, Wargocki P, Vondruskova J. Effect of ventilation on perceived quality of air by building materials - A summary of reported data. In *Proceedings of Healthy Buildings*; 2006; Lisboa. p. 57-62.
141. Roelofsens P. Koolmonoxide en tabaksrook. *TVVL-Magazine*. 1998 May;: p. 18-20.
142. Roelofsens P. The impact of air quality on employee performance - Carbon dioxide as performance indicator for the perceived air quality. *Facility Management Journal*. 2003 September/October;: p. 42-48.
143. Clements-Croome DJ. Work performance, productivity and indoor air. *SJWEH Suppl*. 2008;(4): p. 69-78.
144. Roelofsens P. Nieuw Bouwbesluit gaat voorbij aan gezond binnenmilieu. *TVVL-Magazine*. 2012 January;: p. 24-25.
145. Fang L, Wyon DP, Clausen G, Fanger PO. Impact of indoor air temperature and humidity in an office on perceived air quality, SBS symptoms and performance. *Indoor Air*. 2004; Vol. 14: p. 74-81.
146. Lindeman J, Leiacker R, Rettinger G, Keck T. Nasal mucosal temperature respiration. *Clin. Otolaryngol*. 2007; 27: p. 135-139.
147. Fanger PO, Lauridsen J, Bluysen P, Clausen G. Air pollution in offices and assembly halls, quantified by the olf unit. *Energy and Buildings*. 1988;(12): p. 7-19.
148. Wargocki P, Knudsen HN, Krzyzanowska J. Some methodological aspects of sensory testing of indoor air quality. *Clima 2010*, 10th REHVA World Congress. 2010.
149. Gunnarsen L, Fanger PO. Adaptation to indoor air pollution. *Environment International*. 1992; 18: p. 43-54.
150. Wargocki P, Wyon DP, Fanger PO. Productivity is affected by the air quality in offices. In *Proceedings of Healthy Buildings*; 2000. p. 635-640.
151. Yoshitake H. Occupational fatigue-approach from subjective symptom. Tokyo;: 1973.
152. Nishihara N, Wargocki P, Tanabe Si. Cerebral blood flow, fatigue, mental effort and task performance on offices with two different pollution loads. *Building and Environment*. 2014;: p. 153-164.
153. Tanabe S, Nishihara N. Productivity and fatigue. *Indoor Air*. 2004;: p. 126-133.
154. NPR 3438. Ergonomie - Geluidhinder op de arbeidsplaats - bepaling van de mate van verstoring van communicatie en concentratie. 2007..
155. Russel P. Geluid en het moderne kantoor Helsingborg: Hilanders; 1999.

156. Folsom FW, Koenig TA. The impact of open plan speech noise on employee productivity & satisfaction and the facility solutions. [Online].; 2007. Available from: www.ifma-holland.nl/files/Congressen/The_Impact_of_Open_Plan_Speech_Noise_on.doc.
157. NEN-EN-ISO-9921. Ergonomie - beoordeling van spraakverstaanbaarheid. Delft.; 2003.
158. Bradley JS, Gover BN. Criteria for acoustic comfort in open-plan offices. In Inter-Noise 2004, 33rd International Congress on Noise Control Engineering; 2004; Prague.
159. Bradley JS. Measuring and Predicting Speech Privacy in Open-Plan Spaces. Canadian Acoustics. 2007; 35(3): p. 136-137.
160. Wang C, Bradley JS. NRCC-46314, Sound propagation between two adjacent rectangular workstations in an open plan office. I Mathematical modelling. ; 2002.
161. Gezondheidsraad - Commissie "Uniforme geluidsdosismaat". Omgevingslawaaï beoordelen - Voorstel voor een uniform systeem van geluidmaten ter beoordeling van hinder en slaapverstoring door geluid. [Online].; 1997 [cited 2014 January 12. Available from: <http://www.gezondheidsraad.nl/sites/default/files/9723N.pdf>.
162. Van Deventer FWJ. Basiskennis geluidzonering luchtvaart. [Online].; 2004 [cited 2014 January 12. Available from: http://www.vlieghinder.nl/images/knipsels/Basiskennis_Geluidzonering_Luchtvaart.pdf.
163. Haan F, Van Keken K. Geluidmeting Schiphol failliet. De Volkskrant. 2008 february 5.
164. Haighton M. Schaf wettelijke bescherming tegen lawaai van Schiphol af. De Volkskrant. 2008 september 27.
165. ISSO-89. Binnenklimaat scholen. Rotterdam.; 2008.
166. Elkhuizen B, Nijboer C. Kwaliteitslabel woningen omvat energie en comfort. VV+. 2007 december.; p. 816-821.
167. NEN-1070. Noise Control in buildings - Specification and rating of quality. Delft.; 1990.
168. EN-15251 Ontw. Criteria for the indoor environment including thermal, indoor air quality, light and noise. ; 2005.
169. Clausen G, Carrick L, Fanger PO, Kim SW, Poulsen T, Rindel JH. A comparative study of discomfort caused by indoor air pollution, thermal load and noise. Indoor Air. 1993.; p. 255-262.
170. Reken- en meetvoorschrift Geluidhinder 2006 (annex 1), www.stillerverkeer.nl. 2006.
171. CBS, Statline: www.statline.cbs.nl. Statline. [Online]. [cited 2012 October. Available from: www.statline.cbs.nl.
172. Giebel R, Herderscheë G. Geen woord over uitholling - De grote thema's (2). De Volkskrant. 2012 September 7.
173. Roelofsen P. Healthy Ageing and the built environment. Intelligent Buildings International. 2014; 6(1): p. 3-10.
174. Parsons K. Standards for physical environments occupied by elderly people. Journal of the human environmental system. 2008; Vol. 11, no. 1: p. 13-18.
175. Trouw. Drie doden door hittegolf in verpleeghuis. Trouw. 2006 July 28: p. <http://www.trouw.nl/tr/nl/4324/Nieuws/article/detail/1512083/2006/07/28/Drie-doden-in-verpleeghuis-door-hitte.dhtml>.
176. Tijdschrift voor Ouderengeneeskunde. Verpleeghuis De Geinsche hof. Tijdschrift voor Ouderengeneeskunde. 2007 April;(Volume 32, Issue 2): p. 68-69.
177. Borst V, Schols JMGA, Mackenbach JP. Toegenomen verpleeghuispatiënten bij extreme buitentemperatuur; toename groter bij hitte dan bij koude. Nederlands Tijdschrift voor Geneeskunde. 1997;(141, 2180-3).
178. Garssen J, Harmsen C, De Beer J. The effect of the summer 2003 heat wave on mortality in the Netherlands. Eurosurveillance. 2005;(Volume 10, Issue 7).
179. Van de Leemput J. De tol van de hittegolf. Monitor. 2008 June/July: p. 22.
180. He J, Whelton PK. Elevated systolic blood pressure and risk of cardiovascular and renal disease: Overview of evidence from observational epidemiologic studies and randomized controlled trials. Am. Heart. J. 1999;(vol. 138, Issue 3): p. 211-219.

181. Beemster W. [www.stedebouwarchitectuur.nl](http://www.stedebouwarchitectuur.nl/nieuws/nieuws/brandveiligheid-in-veel-zorginstellingen-schiet.108121.lynkx?utm_campaign=12september2012&utm_content=Nieuws&utm_medium=email&utm_source=eZineSenA). [Online].; 2012 [cited 2012 September. Available from: http://www.stedebouwarchitectuur.nl/nieuws/nieuws/brandveiligheid-in-veel-zorginstellingen-schiet.108121.lynkx?utm_campaign=12september2012&utm_content=Nieuws&utm_medium=email&utm_source=eZineSenA.
182. Luscuere PG, Borst V. Airconditioning in nursing homes till death do us part? In Proceedings of Indoor Air '02; 2002; Monterey. p. 1032-1037.
183. Mohammadi M. Thesis "Empowering Seniors through Domestic homes - Integrating intelligent technology in senior citizens homes by merging the perspectives of demand and supply". Eindhoven University of Technology, Thesis Faculty of Architecture Building and Planning; 2010.
184. Kort HSM. Information Expertise Center - Repository TU/e. [Online]. Eindhoven; 2012 [cited 2012. Available from: <http://repository.tue.nl/737536>.
185. Hollenberg M, Yang J, Haight TJ, Tager IB. Longitudinal Changes in Aerobic Capacity: Implications for Concepts of Aging. *Journal of Gerontology*. 2006; 61A(8): p. 851-858.
186. Fleg JL, Morrell CH, Bos AG, Brant LJ, Talbot LA, Wright JG, et al. Circulation - Journal of the American Heart Association. [Online].; 2005 [cited 2016 February 16. Available from: <http://circ.ahajournals.org/content/112/5/674>.
187. Van den Broek A. Lichtbeleving van de oudere weggebruiker. In Philips-presentation Expertmeeting "LED-lighting A44"; 2011.
188. Aries MBC, Van der Vlies RD, Westerlaken AC. Inventarisatie en vastlegging van de state-of-art kennis over licht en ouderen. TNO-034-UTC-201-00148. Delft: TNO, Bouw en Ondergrond; 2010.
189. Turner PL, Van Someren EJW, Mainster MA. The role of environmental light in sleep and health: Effects of ocular aging and cataract surgery. *Sleep Medicine Reviews*. 2010; 14: p. 269-280.
190. NEN-EN-12464. Light and lighting - lighting of work places - Part 1: Indoor work places. 2003 maart..
191. Hwang RL, Chen CP. Field study on behaviors and adaptation of elderly people and their thermal comfort requirements in residential environments. *Indoor Air*. 2010; Vol. 20: p. 235-245.
192. Schellen L. Verschillen in thermisch comfort tussen jongeren en ouderen. *Thematech-Installaties in de zorg*. 2012; no. 26: p. 15-17.
193. Griefahn B, Künemund C, Gehring U. Evaluation of draught in the workplace. *Ergonomics*. 2002; 45:2: p. 124-135.
194. Fanger PO, Melikov AK, Hanzawa H, Ring J. Air Turbulence and Sensation of Draught. *Energy & Buildings*. 1988; 12: p. 21-39.
195. Roelofsen P. Evaluation draught in surgical operating theatres: proposed revision to (NEN)-EN-ISO-7730. *Journal of Facilities Management*. 2011; Vol. 9, no. 1: p. 64-70.
196. Griefahn B, Künemund C. The effects of gender, age and fatigue to susceptibility to draft discomfort. *Journal of Thermal Biology*. 2001; 20: p. 395-400.
197. Fanger PO, Christensen NK. Perception of draught in ventilated spaces. *Ergonomics*. 1986; 29:2: p. 215-235.
198. Mudde T. Vrouw lijdt meer kou op kantoor dan mannelijke collega. *De Volkskrant*. 2012 September 18.
199. Schellen L, Van Marken Lichtenbelt WD, Loomans MGLC, Toftum J, De Wit MH. Differences between young adults and elderly in thermal comfort, productivity, and thermal physiology in response to a moderate temperature drift and a steady-state condition. *Indoor Air*. 2010; 20: p. 273-283.
200. Hashiguchi N, Feng Y, Tochiyama Y. Gender differences in thermal comfort and mental performance at different vertical air temperatures. *Eur. J. Appl. Physiol*. 2010;(Vol. 4): p. 41-48.
201. Van Luxemburg LCJ, Pernot CEE, Rutten PGS. Van binnenmilieu-klachten tot gezondheidsclassificatie van nieuwe en te renoveren woningen (GCW). 2. Van gezondheidsrisico naar Bouwbesluit-systematiek. 96-CBO-R1285. TNO; 1997.
202. Bronswijk JEMH, Van Dongen JEF, Koren LGH, Pernot CEE. Relatie EPC en gezondheidsrisico's als onderdeel van het kwaliteitsniveau van gebouwen. TNO-2003-GGI-

- RO75, ISBN-90-5986-047-0. Delft: TNO; 2003.
203. Van Gerven PWM, Vos H, Van Boxtel MPJ, Janssen SA, Miedema HME. Annoyance from environmental noise across the lifespan. *J. Acoust. Soc. Am.* 2009 July; 126 (1): p. 187-194.
 204. Houtgast T, Steeneken HJM, Plomp R. Predicting speech intelligibility in rooms from the modulation transfer function. I: General room acoustics. *Acoustica.* 1980; 46: p. 60-72.
 205. Plomp R, Mimpen AM. Speech-reception threshold for sentences as a function of age and noise level. *J. Acoust. Soc. Am.* 1979; Vol. 66: p. 1333-1342.
 206. Plomp R, Duquesnoy AJ. Room acoustics for the aged. *J. Acoust. Soc. A.* 1980 December; 68(6): p. 1616-1621.
 207. FMT Gezondheidszorg. Positieve invloed van dynamisch licht op ernstig verwarde patiënten. FMT Gezondheidszorg. 2010.
 208. De Graaff MJ, Buijs RM, Hoekstra JBL, Fliers E, Holleman F. Melatonine: Fysiologische en patofysiologische aspecten en mogelijke toepassingen. *Nederlands Tijdschrift voor Geneeskunde.* 2006; Vol. 150, no. 36: p. 1971-1975.
 209. Riemersma-Van der Lek RF, Swaab DF, Twisk J, Hol EM, Witte JG, Hoogendijk JG, et al. The JAMA Network - The Journal of the American Medical Association. [Online].; 2008 [cited 2013 June 25. Available from: <http://jama.jamanetwork.com/article.aspx?articleid=273623>.
 210. Varadarjan R. The effect of illumination on medication preparation errors in a long term care facility. Dissertation. Auburn university; 2011.
 211. Harris RW, Reitz ML. Effects of room reverberation and noise on speech discrimination by the elderly. *Audiology.* 1985; Vol. 24: p. 319-324.
 212. Ulrich RS. SMARTech - Scholarly Materials and Research at Tech. [Online].; 2008 [cited 2012 November. Available from: <http://smartech.gatech.edu/handle/1853/25676>.
 213. Wargocki P, Wyon DP. Effects of HVAC on student performance. *ASHRAE Journal.* 2006 October; Vol. 48: p. 23-28.
 214. Kretschmer V, Griefahn B, Schmidt KH. Bright light and night work: effects on selective and divided attention in elderly persons. *Lighting Research and Technology.* 2011; 43: p. 473-486.
 215. Galván VV, Vessal RS, Golley MT. The effects of cell phone conversations on the attention and memory of bystanders. *PLOS ONE.* 2013; Vol.10, Issue 3: p. 1-10.
 216. Goto T, Ito K. The effects of indoor temperature and outdoor air supply rate on learning performance of late-teen students. In *ROOMVENT Proceedings*; 2009; Busan, Korea. p. 934-941.
 217. Maas J. Thesis "Vitamin G - Green Environments - Healthy Environments". Thesis. University Utrecht; 2009.
 218. KPMG. Sustainability - Groen, gezond en productief - The economics of ecosystems & biodiversity (TEEB NL): Natuur en gezondheid. [Online].; 2012 [cited 2013 March 12. Available from: <http://www.kpmg.com/NL/nl/IssuesAndInsights/ArticlesPublications/Documents/PDF/Sustainability/Groen-gezond-en-productief.pdf>.
 219. Roelofsen P. Healthy Ageing - Design criteria for the indoor environment for vital elderly. *Intelligent Buildings International.* 2014; Vol. 6, Issue 1: p. 11-25.
 220. Novieto DT. Adapting a human thermoregulation model for predicting the thermal response of older persons. Leicester, UK: Montfort University, Institute of Energy and Sustainable Development; 2013.
 221. Stevens JC, Choo KK. Temperature sensitivity of the body surface over the life span. *Somatosensory & Motor Research.* 1998; 15(1): p. 13-28.
 222. Roelofsen P. A computer model for the assessment of employee performance loss as a function of thermal discomfort or degree of heat stress. *Intelligent Buildings International.* 2015 February 23; DOI:10.1080/17508975.2015.101107: p. 1-20.
 223. Havenith G. Individualized model of human thermoregulation for the simulation of heat stress respons. *J. Appl. Physiol.* 2001; 90: p. 1943-1953.
 224. Gonzalez RR. Experimental analysis of thermal acceptability. In *NBS Special Publication 491*,

- Thermal Analysis - Human Comfort - Indoor Environments, C13, 10:491; 1977; Gaithersburg, Maryland: US Department of Commerce / National Bureau of Standards. p. 131-151.
225. Sprague CH, McNall PE. The effects of fluctuating temperature and relative humidity on the thermal sensation (thermal comfort) of sedentary subjects. ASHRAE Transactions. 1970;(76, Part 1).
 226. McIntyre DA. Indoor Climate London: Applied Science Publishers LTD; 1980.
 227. Nevins RG, Rohles FH, Springer W, Feyerherm AM. A temperature-humidity chart for thermal comfort of seated persons. ASHRAE Transactions. 1966; 72. I: p. 283-291.
 228. Rohles FH. Thermal sensations of sedentary man in moderate temperature. Special Report. Kansas State University, Institute for Environmental Research; 1970.
 229. Rida M, Ghaddar N, Ghali K, Hoballah J. Elderly bioheat modeling: changes in physiology, thermoregulation and blood flow circulation. International Journal of Biometeorology. 2013 November;(Volume 58, Issue 9): p. 1825-1843.
 230. Takada S, Kolayashi H, Matsushita T. Thermal model of human body fitted with individual characteristics of body regulation. Building and Environment. 2009; Vol. 44(Issue 3): p. 463-470.
 231. Zhang H, Huizenga C, Arens E, Yu T. Considering individual physiological differences in a human thermal model. J. of Thermal Biology. 2001; Vol. 26, Issue 4-5: p. 401-408.
 232. Van Marken Lichtenbelt WP, Frijns AJH, Fiala D, Janssen FEM, Van Ooijen AMJ, Steenhoven AA. Effect of individual characteristics on a mathematical model of human thermoregulation. J. of Thermal Biology. 2004; 29: p. 577-581.
 233. Jacobi J. Stimulus-Organism-Response Reconsidered: An Evolutionary Step in Modeling (Consumer) Behavior. Journal of Consumer Psychology. 2002; 12(1): p. 51-57.
 234. Ahmadpour N, Robert J, Lindgaard G. The thematic structure of passenger comfort experience and its relationship to the context features in the aircraft cabin. Ergonomics. 2014; 57(6): p. 801-815.
 235. Clements-Croome D. Assessing performance of green intelligent buildings. [Online].; 2015 [cited 2016 July 5]. Available from: <http://www.slideshare.net/kcscroom/assessing-the-performance-of-green-intelligent-buildings>.
 236. Fanger PO. Healthy Buildings with moderate enthalpy and low pollution load. Design, Construction and Operations of Healthy Buildings. 1998.
 237. ISSO/SBR. Guideline Healthy Buildings: Indoor environment, productivity and absenteeism. ISSO/SBR. 2002 September.
 238. Kurvers S, van der Linden K, van Beek M. A field study of the performance of the Dutch Adaptive Temperature Limits guideline. In Proceedings of Clima 2007 WellBeing Indoors; 2007.
 239. Hensen JLM, Centnerova L. Is adaptieve thermische behaaglijkheid relevant voor de Nederlandse situatie? Verwarming en Ventilatie. 2002; Vol. 59(4): p. 20-38.
 240. 't Hooft EN. New ways for thermal comfort in office buildings? TVVL-Magazine. 2006 March;; p. 16-22.
 241. Franchimon F. Thesis "Healthy Building Services for the 21st century". Thesis. Eindhoven University of Technology, Department of Architecture, Building and Planning; 2009. Report No.: ISBN 978-90-386-1524-4.
 242. Bluysen PM. The Indoor Environment Handbook: Taylor & Francis Ltd; 2009.
 243. Bazley CM, Vink P. The effects of Expectations and an office environment on comfort experience. In Vink P, Kantola J. Advances in Occupational, Social, and Organizational Ergonomics.: CRC Press Taylor & Francis Group; 2010.
 244. Griefahn B, Künemund C, Gehring U. Wirkung und Bewertung von Zugluft am Arbeitsplatz. Universität Dortmund, Institut für Arbeitsphysiologie ; 1999.
 245. College bouw ziekenhuisvoorzieningen. In perspectief. 2003 May.
 246. Toftum J. Trækgener i det industrielle arbejdsmiljø. Danmarks Tekniske Universitet, laboratoriet for varme- og klimateknik; 1994.
 247. Toftum J, Nielsen R. Draught sensitivity is influenced by general thermal sensation. International Journal of Industrial Ergonomics. 1996; 18: p. 295-305.

248. Zhou G. Impact of airflow direction on perceived draught discomfort. [Online].; 2004 [cited 2011]. Available from: <http://www.ie.dtu.dk/resresults.asp?ID=25>.
249. Mayer E, Schwab R. Untersuchung der physikalischen Ursachen von Zugluft. Gesundheits Ingenieur - Haustechnik - Bauphysik - Umwelttechnik. 1990; 111(Heft 1): p. 17-30.
250. Melhado MA, Beyer PO, Hensen JM, Siqueira LFG. Study of the thermal comfort, of the energy consumption and of the indoor environment control in surgery rooms. In Proceeding Indoor Air; 2005.
251. Linssen JPA. Brand in huis - Overleven of overlijden. Afstudeerverslag (version for publication: 1 october). , Werktuigbouwkunde: Fire Safety Engineering; 2011.

13 Appendix

13.1 Healthy investments in HVAC systems

ABSTRACT. The purpose of this chapter is to demonstrate that it is completely rational to invest in climate installations designed on the highest comfort category.

By means of a study on a office building model it is proved that the benefits of a higher comfort category outweigh the costs of the additional investment, with marginally higher energy costs for cooling.

Depending on the type of climate installation and the comfort class, the additional investment costs can be recovered within six months to two years, due to a higher level of comfort and raised productivity.

The relationship between the thermal environment and productivity makes it possible to design on the basis of productivity improvement, resulting in a comfortable working environment and a consistent financial advantage for the organisation. If the indoor environment is henceforth assessed in the context of comfort and productivity, the participants in the housing process who are generally less interested in the aspects mentioned above will eventually incorporate investments in the quality of the workplace in their objects (in connection with the ability to sell and lease real- estate).

Keywords

Productivity, performance, indoor environment, comfort level, thermal comfort, investments.

13.1.1 Introduction

Office buildings and their related heating, ventilation and air conditioning (HVAC) installations are designed to achieve a safe, healthy, comfortable and productive environment for the occupants in which to function.

To achieve such an appropriate indoor environment there are many HVAC installation concepts which could be considered, each with its own characteristics and potential preferential application. Due to the diversity of the practical installation concepts, it is not always possible to make a simple choice to meet the desired indoor environmental requirements. In order to make a conscious and rational choice for the climate installation together with the corresponding comfort level it is not only necessary to evaluate the direct costs, such as the investment, energy consumption and maintenance, but also the indirect consequential costs influenced by productivity and absenteeism. Furthermore, in respect to energy performance standards, the integral energy economy of the building and the installations has to be taken into account.

This article illustrates, using a reference building model as a study object, the effectiveness of investing in installations for a good indoor thermal climate by means of comparing the costs plus benefits of various types of climate installations and the defined comfort classes (96). In this way, the representativeness is guaranteed and possible research effects in the comparative study are minimized.

13.1.2 Reference building model

The costs and benefits of the climate installations relative to the quality of the indoor thermal climate can be illustrated by the use of a reference building model. The building model comprises 5 floor levels and has 140 office rooms with none opening windows. The dimensional details are shown in Table 13.1.1 The long facades of the building are oriented to face north and south.

Table 13.1.1. Details of reference building model.

<i>Item</i>	<i>Description</i>	<i>Quantity/size</i>
GENERAL	<ul style="list-style-type: none"> - number of floors - building size - total floor area (gross) - total floor area (nett) - building volume (gross) - building volume (nett) - A_0/V-relation ¹⁾ - office space size - total number of offices - building orientation - facades 	<ul style="list-style-type: none"> 5 50.4 x 12.6 x 16 m 3.175 m² 2.722 m² 10.160 m³ 7.350 m³ 0.32 m²/m³ 3.6 x 5.4 x 2.7 m 140 long facades N and S closed
HEIGHT	<ul style="list-style-type: none"> - height between floors - internal free height - building height 	<ul style="list-style-type: none"> 3.2 m 2.7 m 16.0 m
BUILDING EXTERIOR	<ul style="list-style-type: none"> - façade area - window area - roof area - floor area – ground floor - total area building exterior - percentage glass in facades 	<ul style="list-style-type: none"> 2.016 m² 564 m² 635 m² 635 m² 3.286 m² 35 % in N- and S-facades

¹⁾ A_0 = total area of the building exterior [m²]
 V = gross building volume [m³]

To obtain building permission, for an office building and associated technical installations, the energy performance coefficient of the building must not exceed 1.5 [-], this is the ratio of the actual and permitted energy consumption. This dimensionless coefficient is calculated and determined in accordance with the Dutch standard NEN 2916 and the guideline NPR 2917 plus the calculation programme (EPU version v2.02). The underlying criteria for calculating the energy performance coefficient are shown in Table 13.1.2.

Table 13.1.2. Conditions for the energy efficiency calculations.

<i>General</i>	
• Function	: office building (100%).
<i>Construction materials</i>	
• U-values:	
◦ Sun reflecting HR ⁺⁺ glass	: 1.1 W/(m ² .K)
◦ Windows including frame	: 1.7 W/(m ² .K)
• Rc-values:	
◦ Ground floor	: 3.0 m ² .K/W
◦ Exterior facade	: 3.0 m ² .K/W
◦ Roof	: 3.0 m ² .K/W
• Solar heat gain factor glass	: 0.32
• Light transmission factor glass	: 0.60
• Internal sun reflection blinds	: hand operated on South facade (Solar heat gain factor = 0.24)
• Glass percentage	: 35% of the exterior façade area
• Openable windows	: with double-seal closing
• Infiltration	: 0.2 dm ³ /(s.m ²)
• Thermal capacity:	
◦ Floor mass	: ≥ 400 kg/m ²
◦ Ceilings	: closed.
<i>Mechanical services Installations</i>	
• Climate system	: mech. supply and return air with cooling
• Air change rate	: dep. on installation concept/orientation
• Air volume control (fans):	
◦ Installation type 1	: variable air volume
◦ Installation type 2	: constant air volume
• Recirculation	: none (100% fresh outside air)
• Heat recovery	: thermal and moisture recovery wheel
• Room (space) heating	: high temp with radiators
• Humidification	: none
• Heating source	: high efficiency boilers
• Cooling source	: recip. compressor cooling machine
• Domestic tap water	: local electrical boiler, outlets within 3 m.
<i>Electrical installations</i>	
• Installed lighting power	: 12 W/m ² (HF lighting)
• Lighting regulation	: day-light sensing and timer switching.

Only climate installations that meet the specified criteria would be applied. Equally, the criteria for the building and the lighting installations would be the same for each variant. In the event that adjustments to the applied installations are deemed necessary in order to meet the required energy performance coefficient, these will be incorporated within the climate installation.

13.1.3 Indoor thermal climate

Thermal comfort is quantified in the Predicted Mean Vote (PMV). The PMV is the calculation variable, based on the heat balance of the human body, which predicts the average value of the assessment of a large group of healthy people who make a pronouncement on the thermal perception of the environment on the basis of the following seven point scale:

hot	warm	slightly warm	neutral	slightly cool	cool	cold
+3	+2	+1	0	-1	-2	-3

The individual assessments result in a certain spread around the average value. It is therefore useful to predict the percentage of people that will normally experience the thermal environment as uncomfortable, ie the predicted percentage of dissatisfied (PPD). The PPD provides a quantitative prediction in percentage terms of the number of people that are dissatisfied with the climate.

In the reference building model the following comfort categories will be taken into consideration:

- Category A: **high** comfort (-0.2 < PMV < +0.2) (max. 6% dissatisfaction)
- Category B: **standard** comfort (-0.5 < PMV < +0.5) (max. 10% dissatisfaction)
- Category C: **minimum** comfort (-0.7 < PMV < +0.7) (max. 15% dissatisfaction).

The above mentioned requirements are to be met during all working hours.

During the summer period, the following maximum indoor temperatures (56) (rounded up by 0.5 K), are permitted, for all working hours under office conditions:

- Category A: **high** comfort : $T_{\max} = 24.5^{\circ}\text{C}$
- Category B: **standard** comfort : $T_{\max} = 25.5^{\circ}\text{C}$
- Category C: **minimum** comfort : $T_{\max} = 26.5^{\circ}\text{C}$.

¹⁾ The maximum indoor temperatures are based upon the following Dutch comfort convention parameters:

- clothing insulation = 0.7 Clo
- metabolic rate = 1.2 Met
- rel. air speed = 0.15 m/s
- relative humidity = 50%
- $T_{\text{air}} = T_{\text{radiation}}$.

The previously mentioned climate classifications are standardised in EN-ISO 7730 (56), CR 1752 (22) and EN 15251 (23). For comparison, calculations based on the thermal conditions specified by the Government Buildings Agency (GBA) (maximum of 150 weighted temperature transgression hours), are also carried out.

Another method (Adaptive Temperature Limits method (238)) has been developed to be able to evaluate the indoor thermal comfort in (office) buildings. This method, which also distinguishes three comfort classes, is not used in these comparisons since buildings with none opening windows show large discrepancies compared to the in the professional practice still mostly used GBA evaluation method. More information can be found in (240). Both methods are explained in the annexes of the European Standard EN 15251 (23).

13.1.4 Installation concepts

The comparative study is carried out for two different types of climate installation:

- Installation type 1: Mechanical ventilation with cooled air and radiator heating (Figure 13.1.1).
- Installation type 2: Mechanical ventilation with local cooling and heating (Figure 13.1.2).

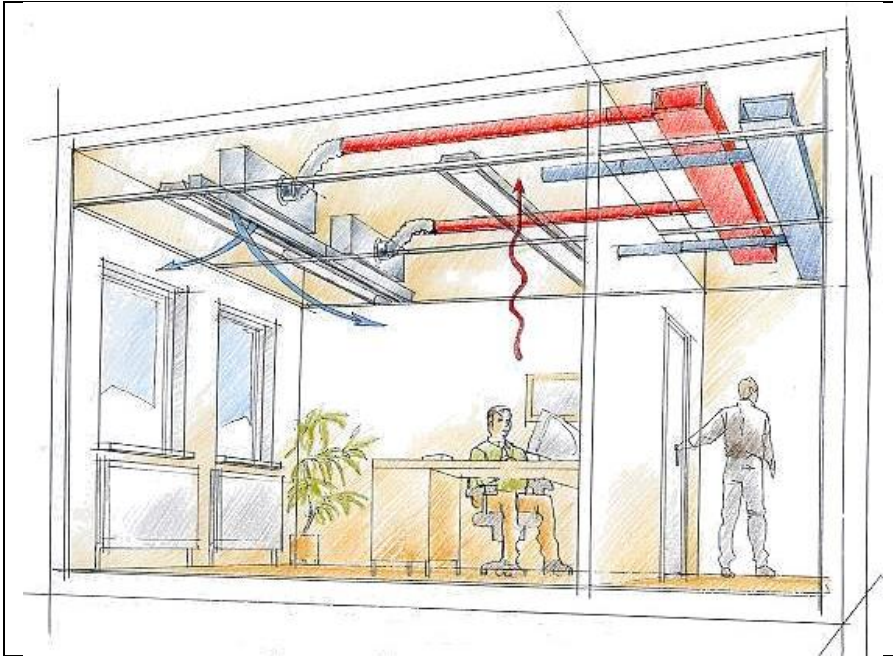

Figure 13.1.1. Mechanical ventilation with cooled air and radiator heating.

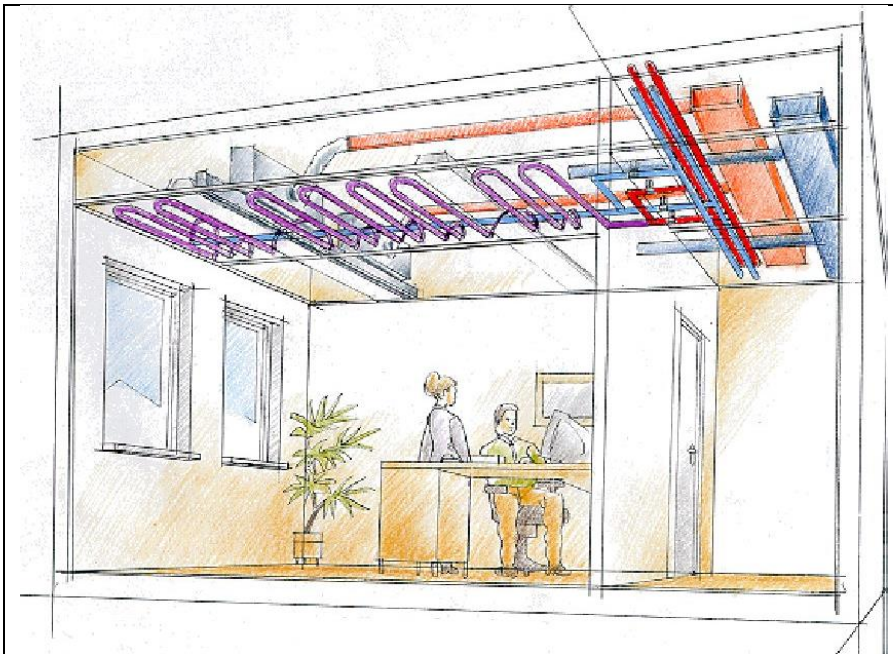

Figure 13.1.2. Mechanical ventilation with local cooling and heating (climate ceiling).

A standard office room, measuring 3.6m x 5.4m x 2.7m with no opening windows and using the ambient conditions for the Dutch reference year, when applied in a validated building simulation model (VA114 computer program) provides the following installation capacities:

Table 13.1.3.: Summary of installation capacities (56) of a standard office room.

Thermal climate	Installation type	North facade				South facade ²⁾			
		Air-flow ³⁾ [m ³ /h]	Q cooling local ⁴⁾ [W]	Tmax ⁵⁾ [°C]	Number weighted hours	Air-flow ³⁾ [m ³ /h]	Q cooling local ⁴⁾ [W]	Tmax ⁵⁾ [°C]	Number weighted hours
Category A	1 ⁶⁾	245	-	24.5	0	385 ⁷⁾	-	24.5	0
	2	110	440	24.5	0	110	900	24.5	0
Category B	1 ⁶⁾	195	-	25.5	0	322 ⁷⁾	-	25.5	10
	2	110	280	25.5	0	110	690	25.5	18
Category C	1 ⁶⁾	165	-	26.5	94	270	-	26.5	83
	2	110	180	26.5	122	110	520	26.5	109
GBA climate	1 ⁶⁾	160	-	26.6	149	255	-	26.8	142
	2	110	172	26.6	150	110	485	26.8	149

¹⁾ Based upon the following indoor heat loads:

- sensible heat from a person : 8 W/m²
- installed lighting load : 12 W/m² (with day-light switching)
- heat from equipment : 20 W/m²

²⁾ Provided with hand operated indoor sun shading

³⁾ Concerns supply of fresh air

⁴⁾ Local cooling capacity, excluding ventilation air at:

- average water temperature of 17°C
- room temperature 25°C

⁵⁾ Concerns maximum air temperature during working hours

⁶⁾ Variable air volume system being applied

⁷⁾ Practically less usable due to the air change rate being greater than 6,0 m³/(h.m³).

The calculated results show that with the application of installation type 1 (cooling by means of ventilation air), for category A, the necessary ventilation rate for south facing areas, greatly exceeds a six fold air change rate. Since this does not achieve an adequate economic solution and because of the possibility of draughts and discomfort, practically this is not a realistic option and is not considered further.

A further issue which arises is the choice of the installation type to be considered for the GBA and category C climate. Due to the more favourable investment cost, the best practical choice would be for cooling by means of the ventilation air and not for cooling by means of climate ceilings, induction units or fan coil units. These local cooling installation types are better applied to indoor thermal climates for categories A and B whereby larger cooling capacities are required.

The reference, therefore, is based upon the GBA climate. The indoor climate during the summer will be achieved by supplying cooled ventilation air.

13.1.5 Annual costs for the climate installation

For the reference building, with various comfort classes and installation types, the annual energy costs can be estimated for conventional heating and cooling sources being applied high efficiency boilers and reciprocating compressor cooling machines.

Table 13.1.4.: Summary annual energy consumption and costs (56) per m² gross floor area.

Thermal climate	Installation type	Energy consumption			Energy costs		
		Gas ²⁾ [m ³ /(m ² .a)]	Electricity ³⁾ [kW.h/(m ² .a)]	Primary [MJ/(m ² .a)]	Gas ⁴⁾ [€/m ² .a]	Electricity ⁵⁾ [€/m ² .a]	Total [€/m ² .a]
Category A	1	-	-	-	-	-	-

Thermal climate	Installation type	Energy consumption			Energy costs		
		Gas ²⁾ [m ³ /(m ² .a)]	Electricity ³⁾ [kW.h/(m ² .a)]	Primary [MJ/(m ² .a)]	Gas ⁴⁾ [€/m ² .a)]	Electricity ⁵⁾ [€/m ² .a)]	Total [€/m ² .a)]
	2	6.0	19.6	392	3.00	2.35	5.35
Category B	1	6.3	19.7	403	3.15	2.37	5.52
	2	6.0	19.2	388	3.00	2.30	5.30
Category C	1	6.3	19.2	399	3.15	2.30	5.45
	2	-	-	-	-	-	-
GBA climate	1	6.1	19.0	390	3.05	2.28	5.33
	2	-	-	-	-	-	-

¹⁾ Not including lighting

²⁾ Energy consumption for room heating

³⁾ Energy consumption for room cooling and transport (fan and pump energy)

⁴⁾ Based on a gas price of € 0.50/m³ (incl. energy taxes but excl. VAT)

⁵⁾ Based on an electricity price of € 0.12/kW.h (incl. energy taxes but excl. VAT).

By an annual anticipated gas consumption of ca. 20,000 m³ and an electricity consumption of ca. 250,000 kW.h for the whole building (incl. lighting, PC's, elevators, copying machines, pantry facilities etc.), the costs for energy would be about € 40,000,- per year. Should the choice have been to install a category A or B climate, instead of the GBA climate, the energy costs would be marginally more (1.5%).

A summary of the investment costs and the annual energy costs are shown in Table 13.1.5.

Table 13.1.5.: Summary annual costs climate installation (excl. VAT) per m² gross floor area.

Thermal climate	Installation type	Investment [€/m ²]	Annual costs			Total [€/m ² .a)]
			Energy [€/m ² .a)]	Maintenance ¹⁾ [€/m ² .a)]	Depreciation ²⁾ [€/m ² .a)]	
Category A	1	-	-	-	-	-
	2 ³⁾	290	5.35	2.90	28.90	37.15
Category B	1	250	5.52	2.50	24.90	32.92
	2 ³⁾	270	5.30	2.70	26.90	34.90
Category C	1	215	5.45	2.30	21.42	29.17
	2	-	-	-	-	-
GBA-climate	1	210	5.33	2.10	20.92	28.35
	2	-	-	-	-	-

¹⁾ The maintenance costs are assumed to be 1% of the investment costs

²⁾ Based on a depreciation period of 15 years at an interest rate of 5.5% (annuity factor = 0.099626)

³⁾ Based on a system with a climate ceiling (most expensive HVCA concept with local heating and cooling).

Remarks:

Practically speaking, systems with local cooling and heating are available in various forms, such as:

- Basic ventilation with radiator heating and ceiling cooling.
- Basic ventilation with heating and cooling by means of induction units.
- Basic ventilation with heating and cooling by means of fan coil units
- Basic ventilation with heating and cooling by means of climate ceilings.

The comparison is based on the use of climate ceilings, i.e. the system with local heating and cooling and consequently the highest investment cost.

13.1.6 Productivity

Research has shown that a good indoor climate has positive effects on the personal productivity and reduces the absenteeism. Productivity is defined as output per employee hour, quality considered. The indoor environment relates to the thermal, acoustic and visual climate and

the air quality. Whenever a building, having little or no climate complaints, is compared with a building with relatively high levels of complaints the productivity is about 10 to 15% higher and the absenteeism 2.5% lower, according to the ISSO/SBR guideline Healthy Buildings “Indoor environment, productivity and absenteeism” (237). See Table 13.1.6.

Table 13.1.6. Effects of indoor environment on productivity and absenteeism (237).

	Increase productivity	Reduction absenteeism
• Good indoor environment	10 - 15%	2,5%
• Good ventilation	1 - 2%	0,5%
• Good temperature	7%	--
• Good temperature control	2 - 3%	0,5%
• Good lighting	2 - 3%	--
• Good day light	--	0,5%

This chapter deals only with the effects of the indoor thermal comfort level on the performance change. On the basis of the investigation of Roelofsen (96) (see Figure 13.1.3.), productivity enhancement can be calculated relative to the reference GBA climate for various situations. The results are shown in Table 13.1.7.

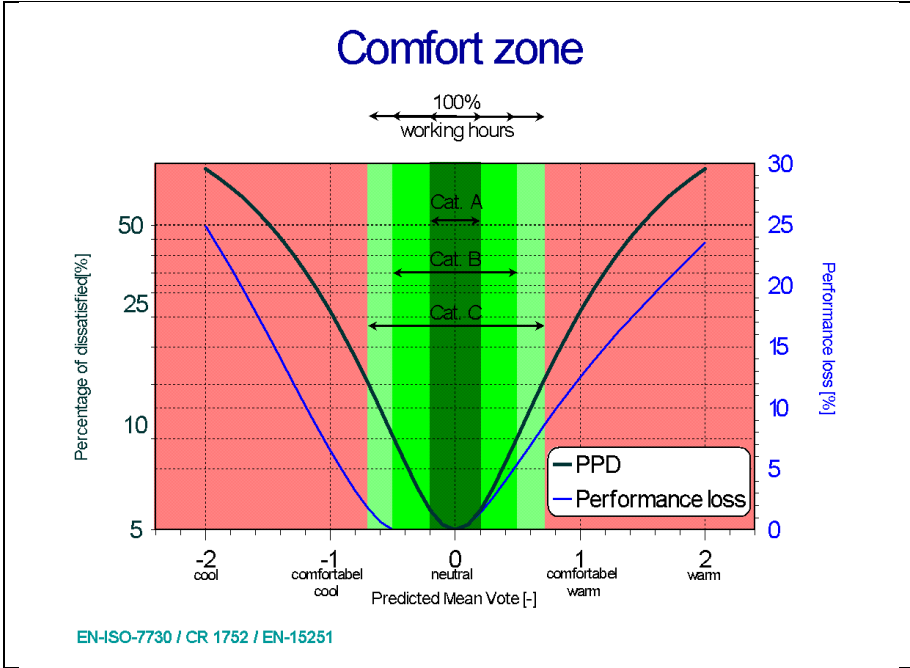

Figure 13.1.3. Comfort level and performance loss (96).

Table 13.1.7.: Summary of productivity improvement compared to the GBA climate

Thermal climate	Installation type	Orientation	Productivity improvement		
			Average [%]	Maximum [%]	Building average [%]
Category A	1	N	-	-	-
		S	-	-	
	2	N	1.1	7.1	0.9
		S	0.7	6.3	
Category B	1	N	0.8	3.8	0.6
		S	0.5	1.9	
	2	N	0.8	3.7	0.7
		S	0.6	3.6	
Category C	1	N	0.2	0.6	0.2
		S	0.2	1.0	
	2	N	-	-	-
		S	-	-	

In the reference building model the number of persons is taken to be, in total 280, with an average annual income of € 35,000,- per person. This means that, inclusive of social costs, pension premiums, accommodation costs etc., the total organisation cost would be about € 65,000,- per employee.

This can be expressed financially, whereby a 1% higher productivity corresponds to a saving of about € 57.32/m² gross floor area. The calculated results are summarised in Table 13.1.8.

Table 13.1.8.: Costs per m² gross floor area and simple return on investment period.

Thermal climate	Installation type	Extra investment ¹⁾ [€/m ²]	Productivity improvement ¹⁾ [€/(m ² .a)]	Extra costs ^{1) 2)} [€/(m ² .a)]	Nett return [€/(m ² .a)]	Return on investment period SPOT ³⁾ [a]
Category A	1	-	-	-	-	-
	2	80.00	51.59	8.80	42.79	1.9
Category B	1	40.00	34.39	4.57	29.82	1.3
	2	60.00	40.12	6.55	33.57	1.8
Category C	1	5.00	11.46	0.82	10.64	0.5
	2	-	-	-	-	-

¹⁾ Compared to the reference GBA climate

²⁾ Includes annual extra costs for energy, maintenance and depreciation (see Table 13.1.5.)

³⁾ SPOT: simple pay out time, defined as (extra) investment / nett return.

13.1.7 Conclusion

For the reference office building using the Dutch conventional GBA-climate with 150 weighted temperature transgression hours, a comparison is drawn for the extra investment costs and productivity improvement results which would apply for two different climate systems (one system with air cooling and the other system with local cooling) and each related to the three higher thermal climate comfort classes (categories A, B and C).

Based on the calculated results, the following conclusions can be drawn:

- In the Netherlands the commonly used GBA climate with 150 weighted temperature transgression hours is poorer in terms of productivity than climate category C having no allowable transgression hours of $PMV \geq +0.5$.
- The additional investment costs for climate installations having full air ventilation cooling (installation type 1) can, when compared to the reference GBA climate installation, be shown to recover these costs within 0.5 and 1.3 years, depending on the comfort class.
- Climate installations with local cooling (installation type 2) recover the extra costs within 1.8 and 1.9 years, also dependent on the comfort class. The differences between the return on investment periods is much smaller for these type of installation compared to installation type 1 (with air cooling).
- The annual energy consumption costs are only marginally higher (1.5%) even with the higher comfort class.

It should be observed that, related to productivity losses, the PMV category A limits are -0.5 and 0 because no productivity losses occur (96) rather than the $-0.2 < PMV < +0.2$ which is mentioned in CR 1752 and EN 15251.

The calculated results clearly show that the extra investment costs for a climate installation designed and based upon a higher comfort level than the GBA-climate can be recovered within six month to two years due to the improvements in the productivity of the occupants. Installations with local cooling have such a small return on investment time difference, for various climate comfort classes, that it is recommended to design for the highest comfort class.

It is, therefore, completely reasonable and rational to invest in installations for a good indoor thermal climate of a higher comfort classification without having to accept allowable high temperature transgressions (no PMV transgressions).

The relationship between the thermal environment and productivity makes it possible to design on the basis of productivity improvement, resulting in a comfortable working environment and a consistent financial advantage for the organisation. If the indoor environment is

henceforth assessed in the context of comfort and productivity, the participants in the housing process who are generally less interested in the aspects mentioned above will eventually incorporate investments in the quality of the workplace in their objects (in connection with the ability to sell and lease real-estate) (96).

13.2 Proposed revision to (NEN)-EN-ISO-7730 - Evaluation of draught in surgical operating theatres

ABSTRACT. The purpose of this chapter is to show that it is advisable to evaluate draught in a room, in this example an operating theatre, in a different manner than the method according to NEN-EN-ISO-7730 (56). The NEN-EN-ISO-7730 is an international standard for the analytical determination and interpretation of the thermal comfort of the human body and the local thermal comfort like for instance draught.

Using a CFD computer program it is possible to evaluate draught in an operating theatre in the design stage, according to different mathematical draught models.

It would seem advisable to begin with the draught model developed by Griefahn et al. (244). The model does, however, need to be modified to include the effects of thermal sensation and the direction of the air stream, so that it becomes applicable to a thermally cool environment ($PMV < 0$) and a vertical air stream, the air pattern prescribed for an operating theatre.

It can be demonstrated that by implementing this proposal in a CFD program, the possibility exists to be able to evaluate, in a responsible fashion, the results for a much broader range of parameters than is currently possible by means of the NEN-EN-ISO-7730 (56).

Keywords

Surgical operating theatres, Temperature, Air, International standards.

13.2.1 Introduction

In the Netherlands almost all surgical operating theatres are provided with a supply air plenum having dimensions of 1,2 meter x 2,4 meter. The application of such a plenum is extremely important in order to ensure that filtered clean air flows from the whole plenum area vertically downwards over the open incision of the patient and, to a certain extent, also over the operating team and tables upon which the surgical instruments are laid out.

Nowadays, due to new insights into infection prevention, the air distribution within an operating theatre proposes to use a much larger supply air plenum of 3,5 meter x 3,5 meter together with a proportionally larger supply air quantity. In this manner, the operating table, the operating team and the surgical instrument tables are fully enveloped by the clean, filtered air from the ceiling. As a consequence, the surroundings and adjacent rooms become less critical objects since the chances of bacterial contamination are significantly reduced.

Such developments therefore not only have an impact on the technical installations but also on the layouts of the surgical departments (245).

Due to the larger plenum and supply air volume, the members of the surgical team would now be “washed over” with cooled air, and as a consequence of the differing activity levels and clothing, it is appropriate to consider any effects of unwelcome draughts which may occur.

13.2.2 Draught

Draught is defined as an unwelcome cooling of a part of the human body as a result of air movement.

Draught, conforming to NEN-EN-ISO 7730

Currently, it is conventional to determine the effects of comfort, caused by draught, through the use of a mathematical skin model, whereby the percentage of complainants can be calculated and predicted using the parameters of air temperature, the average air speed and air turbulence intensity, in accordance with NEN-EN-ISO-7730 (56). The NEN-EN-ISO-7730 is an international standard for the analytical determination and interpretation of the thermal comfort of the human body and the local thermal comfort like for instance draught.

This draught model was based upon a study of 150 test persons, in an air temperature between 20 and 26°C, an average (horizontal) air speed of between 0,1 and 0,4 m/s and a turbulence intensity between 10 and 70%. The model is specifically applicable to occupants with a low activity level i.e. in the main seated (metabolism $\approx 70 \text{ W/m}^2$), and in surroundings where the body is considered to be in a thermally neutral state ($\text{PMV} = 0$).

In an operating theatre the temperature is often lower than 20°C, the metabolic rate is much higher than 70 W/m^2 and the air flow is vertical instead of horizontal. The application of the aforementioned comfort draught model would not appear to be appropriate for evaluating discomfort due to draughts in an operating theatre.

The following parameters used in the comfort model therefore, cannot be applied and need to be re-assessed:

- The metabolic rate and the activity
- The thermal sensation (m.n. PMV < 0)
- The direction of airflow

Influences of metabolism and activity upon the sensation of draught.

Studies carried out by Toftum (246) and Griefahn et al. (244) give an indication as to how far the metabolism and externally transmitted activity heat influences draught.

The draught models of Toftum and Griefahn are based upon the draught model conforming to NEN-EN-ISO-7730.

In Table 13.2.1 a comparison is shown between the applicable parameter ranges for the various draught models.

Table 13.2.1. Applicable ranges for the draught models.

Draught model	Metabolism [W/m ²]	Air temperature [°C]	Average air speed [m/s]	Turbulence intensity [%]
NEN-EN-ISO 7730 (56)	≈ 70	20 - 26	0,1 - 0,4	10 - 70
Toftum (246)	104 - 129	11 - 20	0,1 - 0,4	10 - 40
Griefahn et al. (244)	≈ 60 - 156	11 - 23	0,1 - 0,4	20 - 90

From Table 13.2.1, it would appear that the draught model formulated by Griefahn et al. has the largest applicable parameter range. The Griefahn et al. experiments show that the model which had been developed by them had the largest correlation with the experimental results. Discomfort, due to draught, formulated by Griefahn et al., may be calculated using the following formula:

$$PD = (t_{sk}-t_a).(v_a-0,05)^{0,623} .(3,143+0,37.v_a.Tu).(1-0,0061.(M-W-70))$$

Where:

- PD = the percentage of dissatisfied due to draught [%]
- $t_{sk} = 32,3 + 0,079 * t_a - 0,019 * (M-W)$ [°C]
- t_a = the air temperature [°C]
- v_a = the average air speed [m/s]
- Tu = the turbulence intensity [%]
- M = Metabolic rate [W/m²]
- W = externally transmitted, activity related, heat rate [W/m²].

13.2.3 Influence of temperature upon sensitivity to draught

Another study carried out by Toftum (247) showed that the sensation of cooler/colder temperatures (PMV < 0) significantly increases discomfort. Consequently, the percentage dissatisfaction, as a result of the sensation of draught, was greater as a result of cooler/colder temperatures than by neutral (PMV ≈ 0) temperature. This also seems to explain why persons, active in a cooler environment, complain of draught even when the average air speed is lower.

The influence of the thermal sensation upon discomfort, as a result of draught, is calculated by the following formula presented by Toftum & Nielsen:

$$PD_{cool}/PD_{neutral} = 100/(1+\exp(-\beta \cdot TMV_{cool} - \ln(PD_{neutral}/(100-PD_{neutral})))) \cdot PD_{neutral}$$

Where:

- $PD_{neutral}$ = percentage of dissatisfied due to draught with a neutral thermal sensation ($TMV \approx 0$) [%]
- PD_{cool} = percentage of dissatisfied due to draught in a cooler environment [%]
- β = regression coefficient: -0,829 [-]
- TMV = thermal sensation in a cool environment ($TMV < 0$) [-].

Influence of air flow direction upon draught

All the previously mentioned draught models are based upon a horizontal air stream. Other studies ((248); (249)) indicate that the air stream direction has a dramatic effect upon the feeling of draught discomfort. Occupants subject to an air flow in a downward direction appear to be less conscious of draughts than when in a horizontal air stream.

The influence of the flow direction upon discomfort as a result of draught is expressed in the following formula, developed by Genhon Zhou, below:

$$PD_{flow\ direction}/PD_{neutral} = \exp(d \cdot (t_a - 24)) \text{ [-]}$$

Where:

- $PD_{flow\ direction}$ = percentage of dissatisfied due to draught as a function of flow direction [%]
- d = coefficient, conforming to Table 13.2.2 [-]
- t_a = air temperature [°C].

Table 13.2.2. Coefficient (d) dependent upon the flow direction (248).

Flow direction	d
Vertically downwards	0,12
Horizontal	0
Vertically upwards	-0,05

13.2.4 Calculation results

To give an idea of how the calculated results differ from each other and with the aid of a CFD computer program, the percentage dissatisfaction has been calculated for each model in an operating theatre with a supply air plenum of 3,5 m x 3,5m.

The following parameters, for a surgeon (250), have been used:

- Metabolism : 128 W/m²
- Mechanical efficiency : 0,086 [-]
- Intrinsic clothing resistance : 0,95 clo.

Percentage of dissatisfied due to draught at 1700 mm (neck level) above the floor.

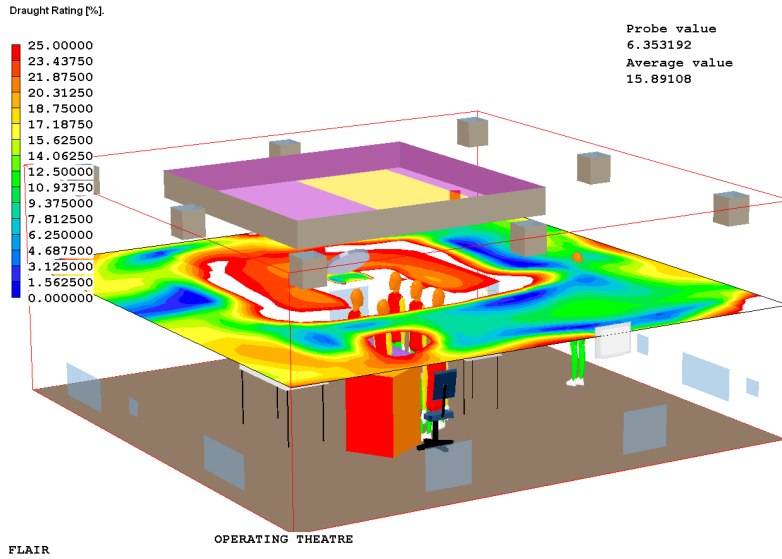

Figure 13.2.1. According to NEN-EN-ISO 7730 (56).

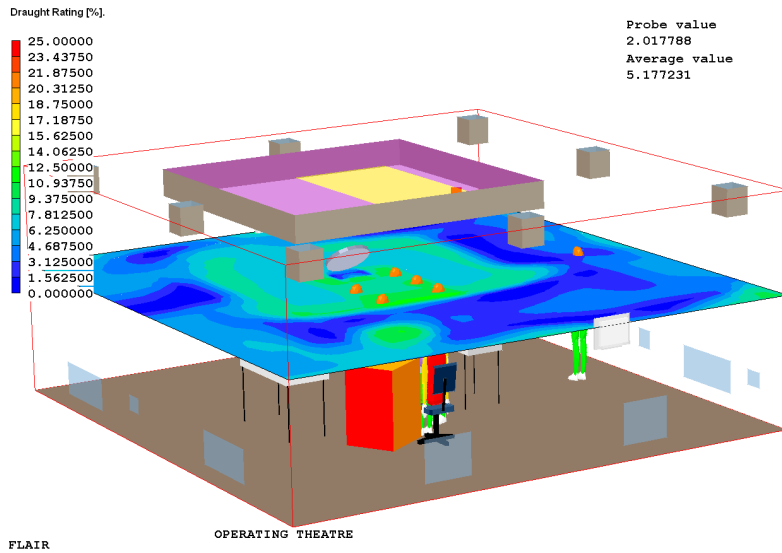

Figure 13.2.2. According to Toftum (246).

Percentage of dissatisfied due to draught at 1700 mm (neck level) above the floor.

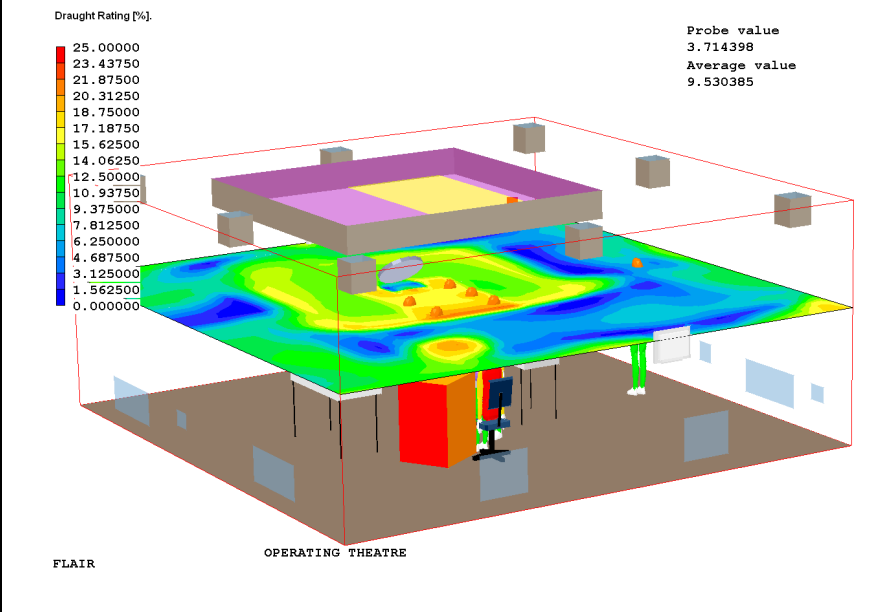

Figure 13.2.3. According to Griefahn et al. (244).

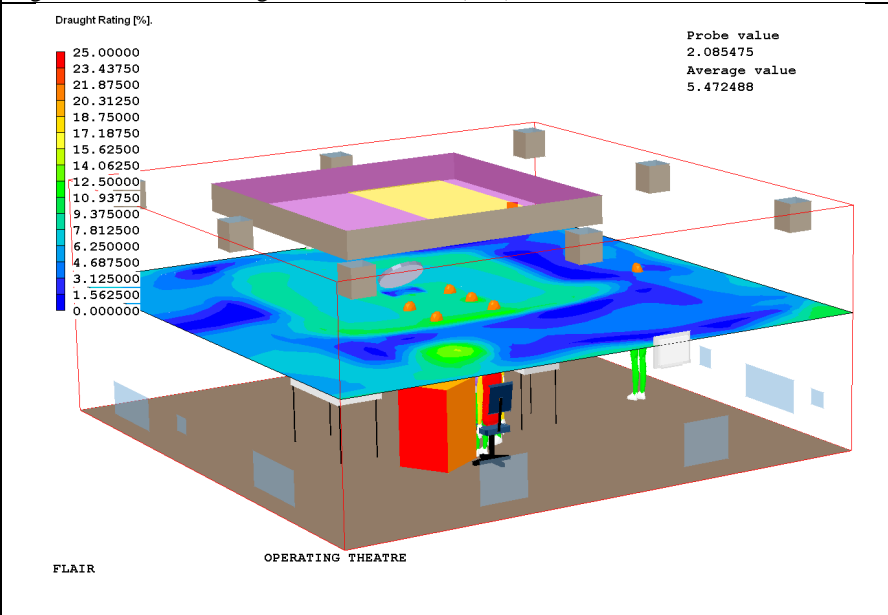

Figure 13.2.4. According to proposition (this study).

13.2.5 Conclusion and recommendation

It is evident that the draught model conforming to NEN-EN-ISO-7730 is not applicable for evaluating draughts in an operating theatre or in any other situations where occupants are not performing a calmly sitting activity ($M \approx 70 \text{ W/m}^2$) in thermally neutral surroundings ($PMV \approx 0$) and with an essentially horizontal air flow.

It would seem advisable to begin with the draught model developed by Griefahn et al. (244). The model does, however, need to be modified to include the effects of thermal sensation and the direction of the air stream, so that it becomes applicable to a thermally cool environment ($PMV < 0$) and a vertical air stream, the air pattern prescribed for an operating theatre.

It can be demonstrated that by implementing this proposal in a CFD program, the possibility exists to be able to evaluate, in a responsible fashion, the results for a much broader range of parameters than is currently possible by means of the NEN-EN-ISO-7730.

Recommendation:

- To further investigate in how far the influence of the air direction, of which the sensation of draught could be a function of the metabolism, may not be fully taken into account in the formula of Griefahn et al.
- The (NEN-EN-)ISO 7730, pertaining to draught, should be reviewed and improved upon, for instance, in the manner mentioned herein.

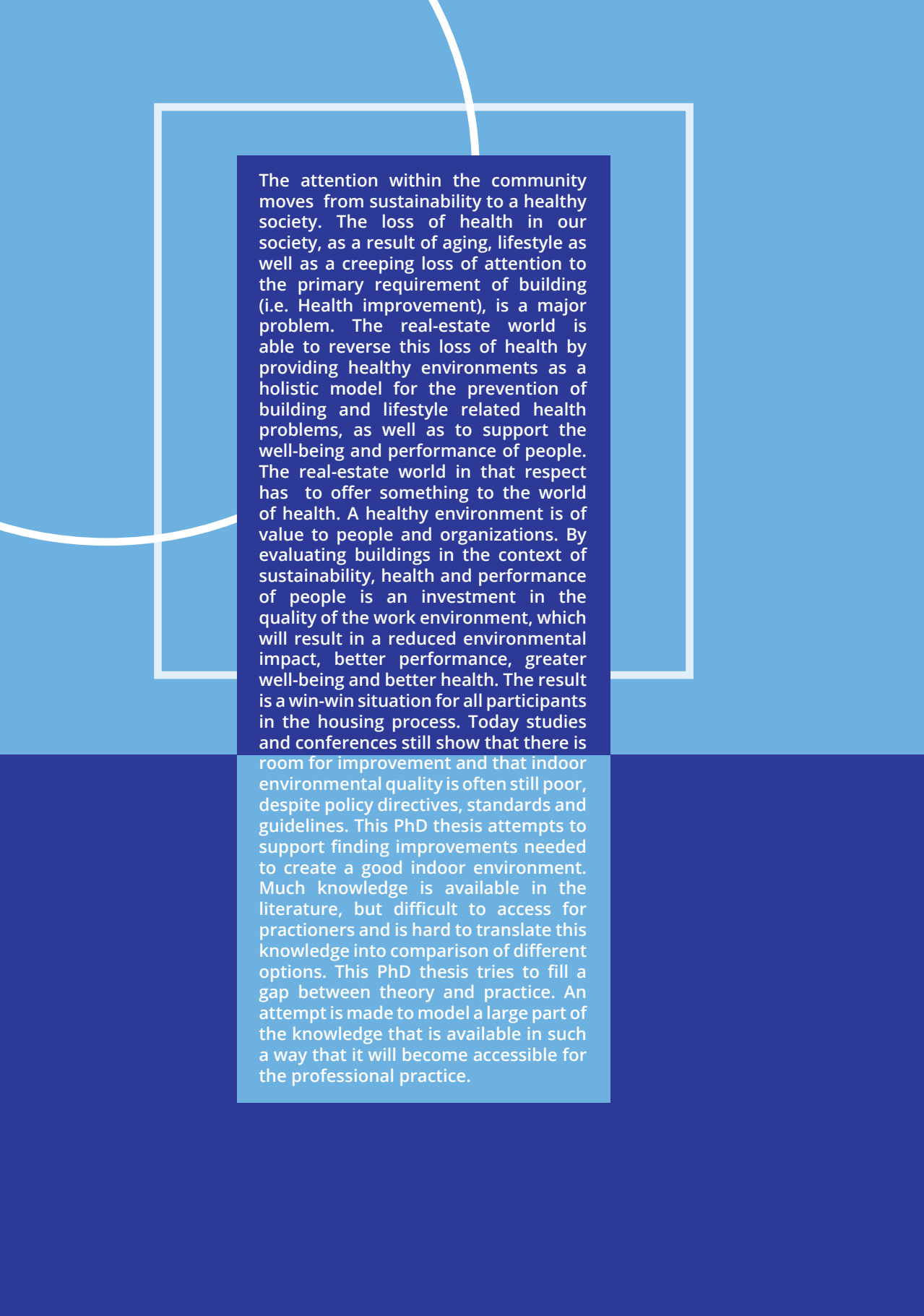

The attention within the community moves from sustainability to a healthy society. The loss of health in our society, as a result of aging, lifestyle as well as a creeping loss of attention to the primary requirement of building (i.e. Health improvement), is a major problem. The real-estate world is able to reverse this loss of health by providing healthy environments as a holistic model for the prevention of building and lifestyle related health problems, as well as to support the well-being and performance of people. The real-estate world in that respect has to offer something to the world of health. A healthy environment is of value to people and organizations. By evaluating buildings in the context of sustainability, health and performance of people is an investment in the quality of the work environment, which will result in a reduced environmental impact, better performance, greater well-being and better health. The result is a win-win situation for all participants in the housing process. Today studies and conferences still show that there is room for improvement and that indoor environmental quality is often still poor, despite policy directives, standards and guidelines. This PhD thesis attempts to support finding improvements needed to create a good indoor environment. Much knowledge is available in the literature, but difficult to access for practioners and is hard to translate this knowledge into comparison of different options. This PhD thesis tries to fill a gap between theory and practice. An attempt is made to model a large part of the knowledge that is available in such a way that it will become accessible for the professional practice.