

THERMAL COMFORT RESEARCH IN A NATURALLY-VENTILATED HIGH-RISE RESIDENTIAL BUILDING

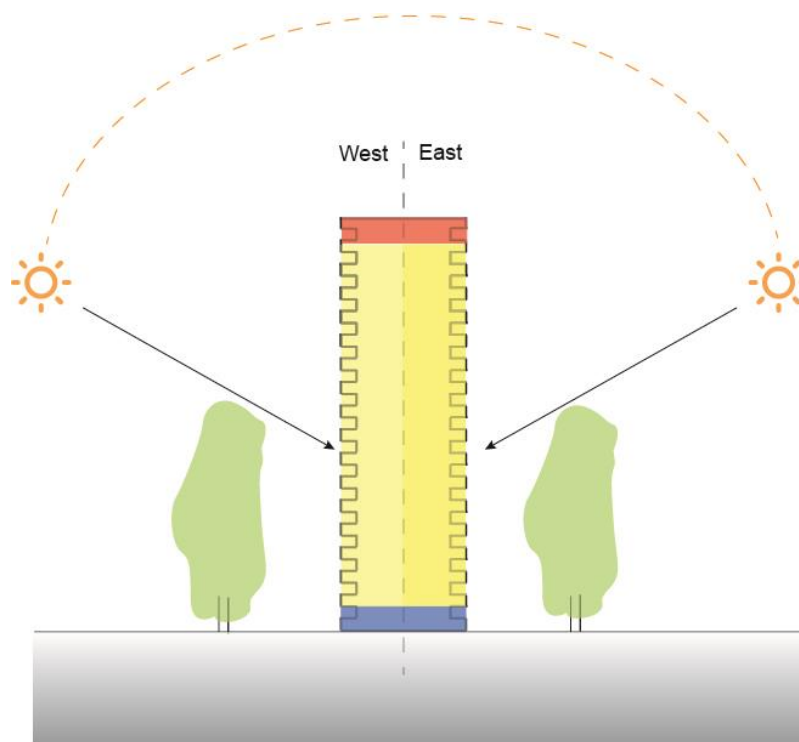

Thermal Comfort Research in Naturally Ventilated High-Rise Residential Building

For one student dormitory with field study and simulation approach

by

Xiangyu Zheng

Graduation Thesis
Master of Science in Building Engineering
at
Faculty of Civil Engineering and Geosciences
Delft University of Technology, Delft, The Netherlands
December 3th 2015

Graduation Committee:

Prof. Philomena M. Bluysen

Dr.Ir. Peter J.W. van den Engel

Dr.Ir. H.R. Schipper

Ir. S.C. Kurvers

Telephone : (31) 659725809

Email: xiangyu-belief@hotmail.com

Abstract

Natural ventilation is a traditional but effective way in buildings to adjust the indoor environment. It has also been proved to be effective in today's design, if applied appropriately. At the same time, there is a growing trend that higher and higher buildings are constructed in the crowded city area. Air velocity, temperature and other factors have already been found to change with height, and the difference in thermal comfort can also affect the architectural design. Therefore, we do need to know the thermal comfort distribution in high rise buildings.

However, research about how to properly realize natural ventilation in a high rise residential building properly is still in early stage. In most cases, designers just choose completely mechanical system to deal with all the climate problems. This may be acceptable for commercial buildings, but in residential buildings natural systems are preferred by most people. The aim of this thesis is to investigate the thermal comfort distribution in a naturally ventilated high rise residential building, and find out if the suitable solutions can be implemented to improve it.

To study this question, a case study was carried out in a high rise student dormitory in Delft, Netherlands in July 2015. Field study (questionnaires and measurement) and CFD simulation were applied simultaneously in the research process to validate each other. The temperature, air velocity, humidity and subjective behaviours were investigated.

The results show how the thermal comfort level is distributed in both building scale and room scale. Based on the analysis about the problems found in the survey, possible refurbishment method is also suggested.

Acknowledgement

After around ten-month work, my master graduation thesis is finally finished. Hereby I would like to thank for all the people who helped me in this process.

I want to thank the whole committee. Peter van den Engel supported me from the beginning of the research. His kindness and patience really backed me up all the time. Roel Schipper helped me to get rid of the toughest stage when I got lost, which avoided us to be bogged down. Prof. Philomena Bluysen gave me lots of academic guidance. Her rigorous attitude towards science made me learn a lot from this research. Stanley Kurvers gave me many detailed help from the beginning of the experiment. That really helped to push the project.

I would like also to thank all the people who provided me help in the thesis. Eric van den Ham and Gerrit Nagtegaal are thanked here for their contribution to the experiment equipment. That plays an important in the whole experiment.

Contents

Abstract	iv
Acknowledgement.....	v
1. Introduction.....	1
1.1 Background	1
1.2 Problem Statement.....	2
1.3 Research Objective	2
1.4 Research Question.....	2
1.5 Research Methodology	3
CHAPTER 2. State Of Art.....	5
2.1 Appropriate Indoor Environment.....	5
2.1.1 Ventilation Rate.....	5
2.1.2 Thermal Comfort Criteria	6
2.1.3 Thermal Neutral Temperature in Different Regions.....	12
2.1.4 Variables for Survey	12
2.1.5 Other Parameters Affecting Comfort.....	15
2.2 Thermal Comfort in Existing High Rise Residential Buildings.....	17
2.3 Principles in Natural Ventilation	18
2.3.1 Driving Force	18
2.3.2 Ventilation Type	19
2.3.3 Natural Ventilation Potential.....	20
2.3.4 Wind Gradient.....	21
2.4 Natural Ventilation Techniques in High Rise building	22
2.4.1 Window	22
2.4.1 Ventilation Grills.....	23
2.4.2 Façade System	24
2.4.3 Other Passive Techniques.....	25
2.5 Conclusion	27
CHAPTER 3. Field Study	28
3.1 Building Information.....	28
3.2 Local Climate.....	32
3.3 Parameters	34
3.4 Instruments	36

3.5 Questionnaire Design	39
3.6 Field Survey Procedures	40
3.6.1 Survey Period	40
3.6.2 Survey Process.....	41
3.7 Survey Basic Results	47
CHAPTER 4. Simulation Model.....	49
4.1 Model information	49
4.2 Accuracy Analysis	54
CHAPTER 5. Results Analysis	56
5.1 General Comfort.....	56
5.2 Building Scale Analysis	66
5.2.1 General Temperature Comparison	66
5.2.2 Temperature Comparison of Same Floor&Side.....	67
5.2.3 Temperature Comparison of Different Floor	69
5.2.4 Temperature Comparison of Opposite Side	72
5.2.5 Wind velocity Comparison.....	73
5.2.6 Humidity Comparison.....	74
5.2.7 Summary and Conclusion	75
5.3 Room Scale Analysis	76
5.3.1 Temperature Distribution.....	76
5.3.2 Air velocity distribution.....	85
5.3.3 Summary and Conclusion	95
CHAPTER 6. Discussion and Refurbishment Possibilities	96
6.1 Thermal Comfort Distribution	96
6.2 Problem Analysis.....	104
6.3 Solutions and Recommendations.....	106
6.3.1 Building Scale Strategy.....	106
6.3.2 Rooms Scale Design	109
CHAPTER 7. Conclusions and Recommendations.....	116
7.1 Conclusions.....	116
7.2 Recommendations and Further Research	118
References	120
Appendix.....	124

A. Questionnaire	124
B. List of Figures	130
C. List of Tables.....	134
D. Field Study Results	134
E. Simulation results for recommendations.....	135

1. Introduction

1.1 Background

High rise building is a growing trend in many big cities all over the world, especially in Asia. In 2014, 3 high rise buildings more than 200m were built in Europe and the trend will keep growing [1]. Though lots of high rise buildings spring up in the world every year, most of them are very similar in the huge amount of energy consumption and little access to the nature.

Because of the invention of modern HVAC (heating, ventilating, and air conditioning) systems, architects might assume that they create buildings without consideration about the building climate issue.

Due to the high wind velocity at high altitude, mechanical ventilation systems are usually applied in most high rise buildings. Though mechanical systems can provide an acceptable temperature and humidity during most of the time, they do not guarantee a good indoor environment. According to research by Seppanen, the prevalence of the Sick Building Syndrome (SBS) in mechanically ventilated buildings is typically higher by roughly 30% to 200% than in naturally ventilated ones [2].

Comfort is also an important issue in residential buildings. More than 40% of the users of high rise buildings want to have an operable window to permit fresh air or some other access to the outside [3]. A naturally ventilated building can largely increase the satisfaction and provide a healthier indoor environment, which is also related to productivity. Residents in a naturally ventilated building tend to work more efficiently than those who work in a mechanically ventilated building [4]. Although productivity for residential buildings is less important than for office buildings, it is likely that the users will appreciate the contact with the external climate, which could increase the value of the property.

Energy is another main issue when choosing between natural ventilation and mechanical system. Based on related research, natural ventilation systems can help to reduce around 40% of the energy consumption in residential buildings, compared with mechanically ventilated ones [5].

Natural ventilation can be a very effective way to improve the thermal comfort level and decrease energy consumption. However, we still need to do more research about the thermal comfort in high rise buildings, before we can really make “climate design”.

1.2 Problem Statement

Although there are some high rise buildings with natural ventilation systems, the real thermal comfort has been checked only in few of them, especially not in residential buildings. It is not clear about how residents feel in these naturally ventilated high rise buildings and whether these designs are good from thermal comfort perspective. If we want to make future architectural designs better, we do need do know what is happening in the buildings.

1.3 Research Objective

To solve the problem above, it is needed to investigate the thermal comfort distribution and main causes of discomfort in existing high rise buildings. Since there might be spatial difference, it is essential to research this topic in both building scale and room scale. If such a research will point out specific problems, solutions will need to be found for these.

1.4 Research Question

How can we naturally ventilate high rise residential buildings resulting in good thermal comfort?

Sub research questions:

The above question can be divided into smaller questions below:

1. How do residents really feel in this building?

The residents' real feeling is vital in the research. The general comfort level, thermal comfort, the sensation to air velocity and many other factors should be checked to answer this question.

2. What is the main disturbance affecting residents' thermal comfort in the naturally ventilated high rise buildings?

Because of the first question, we have already known the residents' sensation in the building. Then it is interesting to further research what makes them feel uncomfortable. That is the necessary prerequisite to find out the specific solutions for the building.

3. How can we improve the thermal comfort by natural or passive solutions?

Apart from general rules, feasible solutions to improve the thermal comfort in this specific building are also needed. Since the owner has no plan or budget to refurbish the building in the short term, the refurbishment advice will be more introductory in this stage.

1.5 Research Methodology

In order to answer the questions above, multiple research methods have been combined with each other. Simulation, Measurement and Questionnaire Survey are the main research methods that have been applied in this study. The relations between the three different methods are showed in Figure 1:

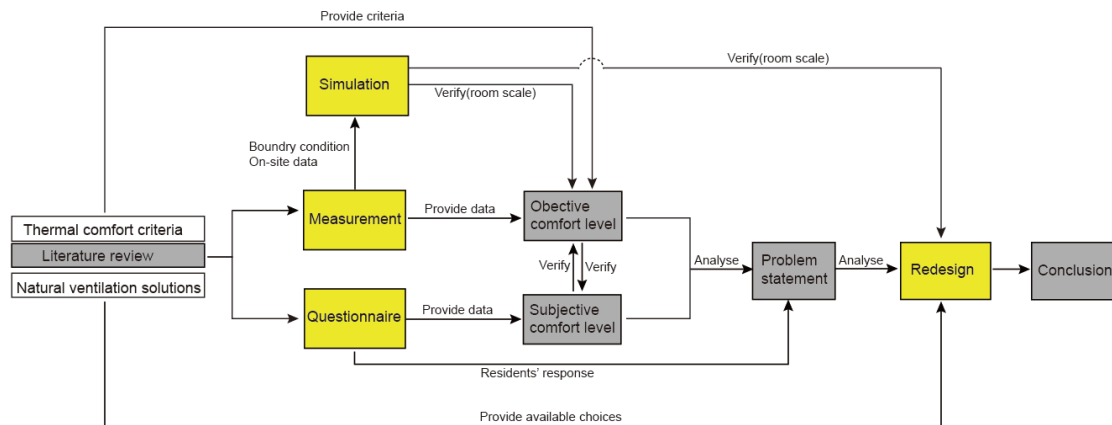

Figure 1: Workflow of the research

The literature review is the first stage. Measurement methods, questionnaire template, local climate and other necessary information will be derived from the literature. On the basis of that, a detailed survey plan can be made.

The field study will consist of two parts: a questionnaire survey and an on-site measurement campaign. In the experimental period, the measurement campaign will record the climate data, which can be compared with the standard to check the objective thermal comfort level. The recorded data will also be used to provide boundary conditions for the simulation. On the other hand, the questionnaire survey focuses on the subjective feeling of the residents, which can be used to verify the objective thermal sensation. It can also help the researchers to find out what are the main problems from residents' perspective.

Since it is not predictably feasible to record the data at all the corners in the room in different cases, simulation will be used to verify the thermal comfort level in various situations. Setting up too many equipment to measure temperature and air velocity will seriously affect the residents' normal life. Moreover, not so many sensors are available. With the help of CFD simulation, we can simulate any situation at low costs.

Based on the field study results, the problems will be analysed. It is expected that this analysis will identify the predominant factor that causes discomfort. If the comfort level is not good enough, suitable natural solutions will be given to improve the thermal comfort. With the help of CFD simulation, it is also possible to verify the effect of the new design.

CHAPTER 2. State Of Art

2.1 Appropriate Indoor Environment

Natural ventilation systems do not only provide fresh air, but also affect the indoor thermal environment a lot. Since the research focuses on thermal comfort, we have to pay attention to the quality of the indoor environment. What kind of indoor environment is expected by the residents? How to judge whether an indoor environment is good or not? What are the criteria for the indoor environment? These kinds of questions will be answered in this section.

2.1.1 Ventilation Rate

Ventilation is changing of air in an enclosed space [6]. It is a general way to provide fresh air for the occupants. The freshness of the air is related to the Indoor air quality (IAQ), though is a more complex issue. Lots of criteria, such as Carbon Dioxide (CO₂) concentration, pollution, flavour, are considered in an IAQ check. Since ventilation can refresh the air completely, it is the ultimate strategy to control IAQ.

In the building codes of most countries, ventilation rate (time/hour) is a basic but very important criterion to judge whether a ventilation system is qualified. It means how many times the indoor air volume is replaced by fresh air per hour. According to the standards in different regions, there are various limits to ventilation rate. A ventilation rate of 0.5h⁻¹ is commonly agreed upon in most European countries [7]. The value can be further categorized by different type of rooms. In Netherlands, the requirement for kitchen is 21dm³/s, which is higher than that for rooms with other functions.

The common way to check the ventilation rate is to calculate it by the size of the extractor (m³/h) and supply openings. In the most residential buildings in Netherlands, there are extractors to guarantee minimum ventilation rate. Hence it is

only needed to check whether the fan works well and the size of the fan is appropriate, and whether sufficient supply air can be provided through grills or ducts elsewhere in the room.

To evaluate the freshness level of a certain point, the local mean age needs to be checked. The local mean age of air at a point represents the time the supply air takes to reach that point [8]. However, the age of air is difficult to measure on site. The common way is to check it in CFD simulation.

2.1.2 Thermal Comfort Criteria

To assess whether the thermal comfort is satisfying, a series of criteria should be given at the beginning. How to define good thermal comfort? This question will be answered in this section.

The research about thermal comfort was set up since the 1930s. Generally, there are two main widely accepted theories about thermal comfort: the steady-state model by Fanger and the adaptive model by De Fergus [9]. In the current standards, these two theories are combined to provide more sophisticated criteria from different perspective.

Fanger s Thermal Comfort Theory

The steady-state model is the most commonly used one for air-conditioned space. Fanger developed theories and formula of human body heat exchange [10]. In his model, the human body is assumed to get thermal equilibrium in a stationary situation, which means that the energy released by the body's metabolism is equal to energy removed from the area [11].

To evaluate the indoor climate, a Predicted Mean Vote (PMV) system was developed. In this scale, the thermal comfort level can be an integer. There are two systems, varying from -5 to 5, or varying from -3 to 3. The later one is used in the ASHRAE standard. The meaning of the scale is showed in Table 1.

Table 1: seven-point PMV thermal sensation scale

-3	-2	-1	0	1	2	3
Cold	Cool	Slightly Cool	Neutral	Slightly warm	Warm	Hot

Since people's perception usually differs, PPD (Predicted Percentage Dissatisfied) was introduced by Fanger to check the thermal comfort level from statistical perspective. The PPD predicts the number of thermally dissatisfied persons among a large group of people [21]. There is also relationship between PMV and the percentage of people that experience the environment as warm or cold [11]. The relationship is showed in Figure 2.

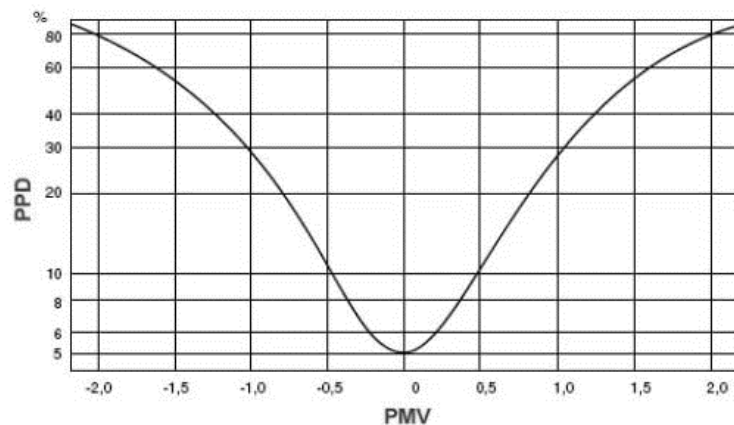
**Figure 2: PPD as function of PMV**

It should be noticed that the theory is based on a specific environment. An air velocity of 0.15m/s and a relative humidity of 50% were assumed as the prerequisite. In reality, the air velocity and humidity will definitely fluctuate. The upper limit for relative humidity is 70% and the lower limit is 30%. Based on these data and assumption, a set of neutral temperatures were derived.

Based on lots of field surveys all over the world, de Dear and Brager stated that PMV prediction fits to air-conditioned buildings well. However, the result for naturally for naturally ventilated buildings was not predicted precisely by the PMV theory [12].

Adaptive Thermal Comfort Theory

Nicol and Humphreys established the adaptive thermal comfort theory in 1970s [9]. This theory is widely used in naturally ventilated buildings all over the world. According to the research by Nicol et al, in a naturally ventilated environment, a thermal balance model does not reflect people's feeling correctly. The adaptive thermal comfort theory shows the principle below:

If a change occurs such as to produce discomfort, people react in ways which tend to restore their comfort [13].

For example, if the weather turns cold and as a result of this, the indoor temperature decreases, the residents will wear more clothes to stay warm. As a result, they still can feel comfortable in the new situation.

Defined by de Dear, naturally ventilated buildings are “buildings with operable windows and ceiling fans within small single or dual occupant offices that afford high degrees of adaptive opportunity” [14]. The adaptive thermal comfort thereby is widely used in naturally ventilated buildings that are very common in tropical and subtropical regions like Southeast Asia and Middle East. Since the theory is “adaptive”, it also indicates that it might adapt to local climate, leading to a different neutral temperature for adaptive thermal comfort.

From Figure 3, we can find that 90% of people will feel the temperature acceptable in an environment with 29 °C, while it is 30 °C outside. If it is mechanically cooled, the temperature needs to be lowered to 23 °C, which undoubtedly requires much more energy.

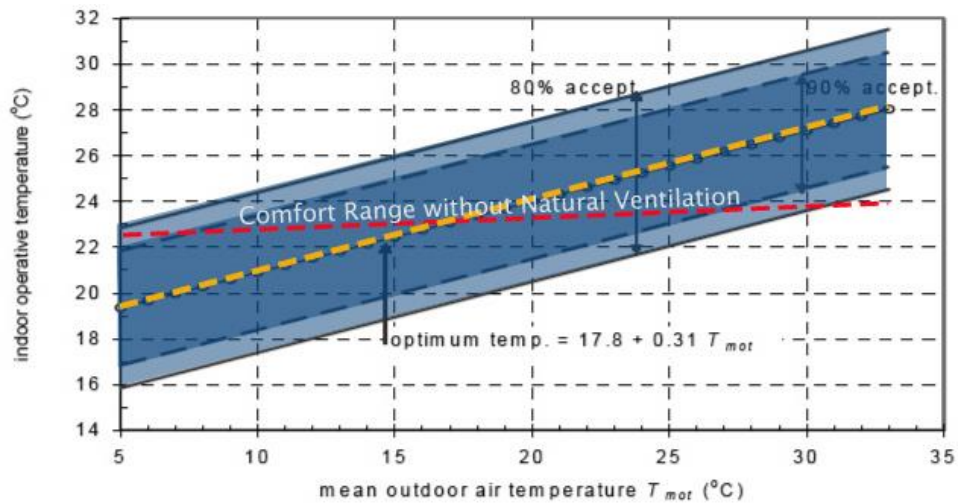

Figure 3: Adaptive thermal comfort [1]

The perceived temperature can be lowered by air movement in a free-running building to some extent.

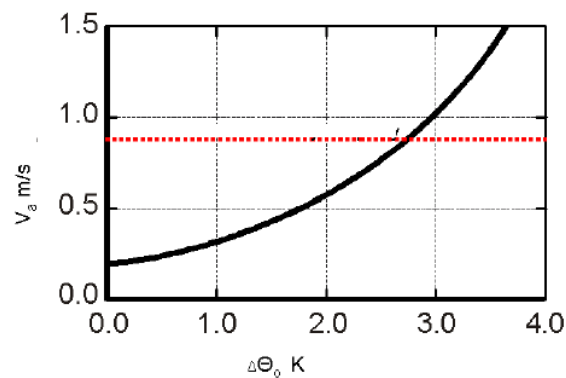

Figure 4: Wind velocity and perceived temperature variation [15]

If there is breeze of wind, the upper limit for acceptable indoor operative temperature can be further increased because of the evaporative effect. As shown in Figure 4, we can find that a breeze of 0.8m/s can reduce 2.6 °C perceived temperature. This kind of change can be realized by natural wind or a fan. Though the temperature does not really change, people may feel much cooler. However, the wind velocity limits are different in different regions. In Europe, air speeds appropriate for indoor environments with mechanical system do not exceed 0.2 m/s [1], while air velocity of 1 m/s is the upper limit [16].

Residents' expectation for thermal neutral temperature differs, depending on a set of variables, such as area, education, etc. According to Jie Han et al, when the operative temperatures are the same, the Mean thermal sensation vote of a rural area is 0.4°C higher than that of the urban area [18]. Therefore, it is better to make on site measurement and survey and refer to local research, rather than just apply the standard.

There are some conditions to apply adaptive thermal comfort theory:

- (1) Spaces cannot have a mechanical cooling system or just mechanical ventilation with unconditioned air. In either situation the windows should be the primary way to adjust thermal comfort.
- (2) Occupants must be able to adapt their clothing to the environment freely.
- (3) The theory is valid when the temperature ranges from 10°C to 33°C. [48]

Criteria Chosen

“Indoor environment-related input parameters for design and assessment of energy performance of buildings for indoor air quality, thermal comfort, lighting and acoustics” NEN-EN-15251 is chosen as the criteria to judge whether it is thermally comfortable in this research.

Table 2: Categories of the building types

Category	Explanation
I	High level of expectation and is recommended for spaces occupied by very sensitive and fragile persons with special requirements like handicapped, sick, very young children and elderly persons
II	Normal level of expectation and should be used for new buildings and renovations
III	An acceptable, moderate level of expectation and may be used for existing buildings
IV	Values outside the criteria for the above categories This category should only be accepted for a limited part of the year

Different kinds of buildings have different requirement in the indoor environment quality. The detailed classification is shown in Table 2.

The running mean-temperature can be calculated by a function of external temperature. Exponentially weighted running mean of the daily mean external air temperature Θ_{ed} is such a series, and is calculated from the formula:

$$\Theta_{rm} = (1 - \alpha) \cdot \{ \Theta_{ed-1} + \alpha \cdot \Theta_{ed-2} + \alpha^2 \Theta_{ed-3} \dots \} \quad (1)$$

This equation can be simplified to

$$\Theta_{rm} = (1 - \alpha) \Theta_{ed-1} + \alpha \cdot \Theta_{rm-1} \quad (2)$$

Where

Θ_{rm} = Running mean temperature for today

Θ_{rm-1} = Running mean temperature for previous day

Θ_{ed-1} is the daily mean external temperature for the previous day

Θ_{ed-2} is the daily mean external temperature for the day before and so on.

α is a constant between 0 and 1. Recommended to use 0,8

When the running mean-temperature is available, we can refer to Figure 5 to find out the operative indoor temperature that is suitable for the situation. Each point responds to an upper limit and a lower limit, which show the comfort zone for the room.

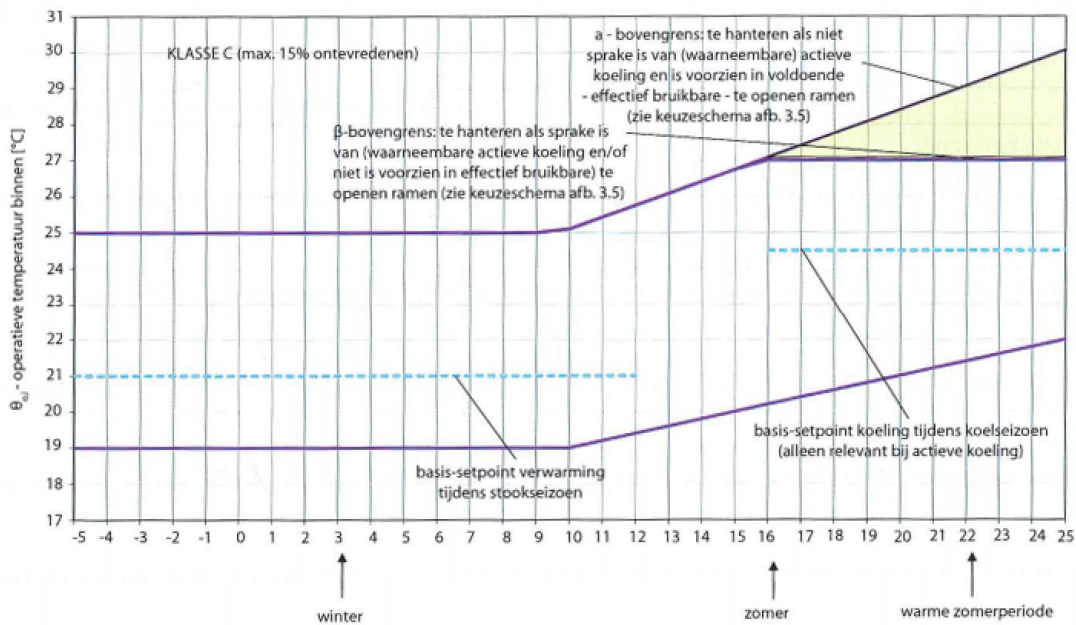

Figure 5: Class C- requirement for the operative indoor temperature, related to running mean outdoor temperature [62]

2.1.3 Thermal Neutral Temperature in Different Regions

In the building that will be investigated later, residents come from all over the world, which make their background vary a lot. This might be an important factor in their sensation. Hence, the thermal neutral temperatures in different regions are compared here.

In Section 3.7 of the report, the statistical data of the residents' nationalities are analyzed in detail. According to the investigation, Indian, Chinese and Greek form the majority in the interviewees. However, most of them have been living in Netherlands for around one year, which allowed them to adapt to the local climate. As a consequence, the thermal neutral temperature of these three countries and the Netherlands are needed.

In summer, the comfort neutral temperature is 29.2°C in India [55], while that is 26°C in China and 28.5°C in Greece [56] [57]. According to NEN-EN 15251[54], the residents feel neutral when the temperature ranges from 23-26 °C in a building with mechanical heating system in Netherlands. The exact temperature depends on the outdoor temperature.

We can find that the thermal neutral temperature is highest in India, and followed by Greece, China and Netherlands. However, the interviewees from these 3 countries react to the climate in a completely different way. This will be explained in Section 5.2 in detail.

2.1.4 Variables for Survey

To apply these theories in reality, occupants' feeling needs to be measured to get a conclusion of the indoor thermal comfort level. The main parameters and the ways to measure them are explained in detail. There are four types of common measurements in comfort surveys:

(1) Physical Measurement

There are four important physical variables in thermal comfort theory:

Air temperature (T_a)	[°C]
Radiant temperature (T_r)	[°C]
Air velocity (v)	[m/s]
Relative Humidity (H)	[%]

Radiant temperature is more complicated to measure. Hence, it can be calculated from globe temperature by the equation below:

For a 40 mm diameter globe

$$T_r = T_g + 4.02v^{0.5}(T_g - T_a)$$

Operative temperature (T_{op})°C is used in ASHRAE 55 and EN 15251 for the standard comfort temperature. This parameter cannot be measured directly, but can be calculated by the equation below:

$$T_{op} = 0.5 T_a + 0.5 T_r$$

Accuracy:

For temperature, 0.5 °C is expected can achievable by common instruments. 0.1 m/s is expected to be guaranteed for air velocity measurement. 5% RH is needed for humidity measurement [59].

(2) Subjective Measurement

Subjective measurement is intended to check the residents' subjective perception. To understand how they really feel, a questionnaire survey is designed to research this question.

The questionnaire needs to be carefully designed to find out the real answer in a correct way. It should be noticed that what you interpret a question is often different to what others understand, so it is wise to check how other people understand the questions before the survey [19]. Questions containing inductivity should be avoided, since they will affect the residents' judgement.

If we want to get a scientific result of the subjective measures, specific survey methods and sample size is necessary. Larger sample size of the survey provides better accuracy for the research, but it will also bring extra cost. To provide useful amount of information, a sample size containing at least 20 subjects is needed for an efficient questionnaire survey [13].

(3) Behavior

Occupant's behaviour, such as window open/closed, fans on/off, also plays an important role in thermal comfort.

In a naturally ventilated space, people always have high freedom to control the system, especially in residential building. This will play an important role in the ventilation level [7]. Lack of understanding of the system usually leads to inappropriate ventilation result, and the ventilation rate can differ a lot.

Occupant behaviour also affects the simulation results to a large extent. Though the simulation softwares are becoming more and more precise nowadays, there are often large discrepancies between calculated and measured performance of the building. Occupant behaviour is the main cause of the inaccuracy, and usually it is quite difficult to include it in the simulation [39].

Due to these two reasons, a survey about the occupants' behaviour is needed to help to reduce the deviation and error in the research.

Questionnaire is main way to research the interviewees' behaviour. Various questions can be included in the questionnaire. At the same time, some information, such as whether the window is used properly, can also be observed by the researcher. That can verify the response of the residents and provide more accurate data.

2.1.5 Other Parameters Affecting Comfort

Though thermal comfort can be expressed by PMV and PPD as a whole, thermal dissatisfaction can also be induced by unwanted cooling or heating of one particular part of the body [21]. Therefore, there are some other parameters related to thermal comfort, which might affect the indoor comfort level.

Turbulence Intensity

In 1988, Fanger stated that an air flow with high turbulence intensity causes more dissatisfaction, compared with the air flow with a more homogeneous temperature and constant velocity [27].

Local air temperature, local mean air velocity and local turbulence intensity are the parameters in this calculation. Turbulence intensity (T_u) is a dimensionless number indicated in percent (%). Increasing turbulence intensity makes the residents more sensitive to the air movements, and it leads to a 'rather cool' thermal sensation [26].

It is possible to measure the turbulence intensity with directional sensors by calculating the standard deviations of the velocity components. However, this requires a special sensor which is fast and small enough to follow the velocity fluctuations [22].

Vertical Air Temperature Difference

People may feel the environment uncomfortable if the air temperature difference between head and ankles is high. As shown in Figure 6, the relationship between percentage dissatisfied and vertical temperature difference follow the graph below:

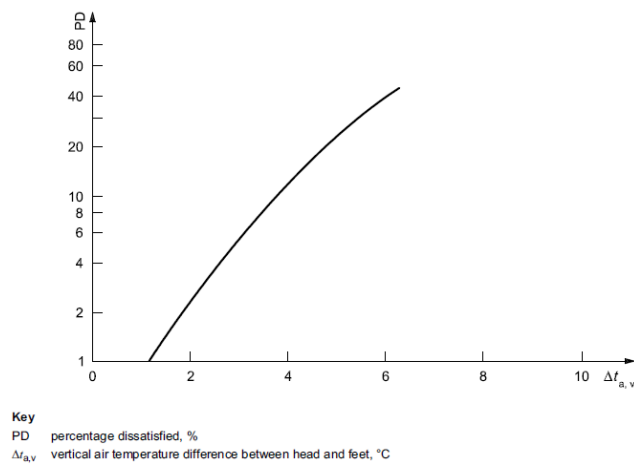

Figure 6: Local discomfort caused by vertical air temperature difference [21]

Warm and Cool Floors

When the floor is warm or cold, people may also feel dissatisfied because they can feel it by their feet. This might be related to the occupants' shoes, so further detailed research is needed.

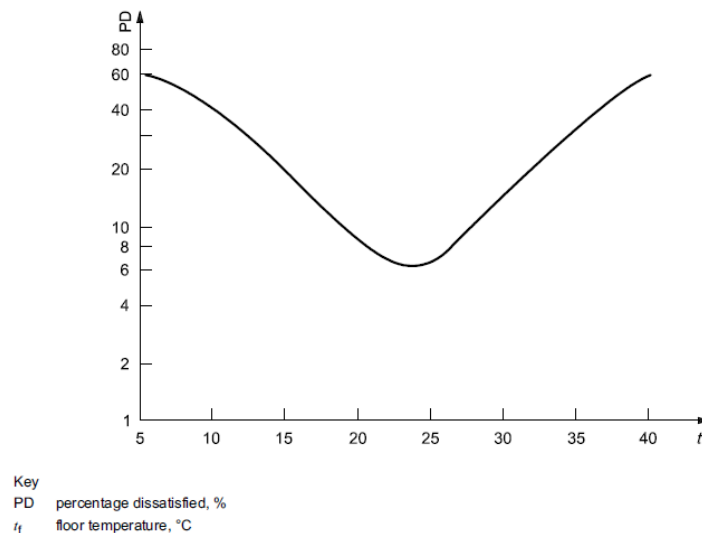

Figure 7: Local thermal discomfort caused by warm or cold floors [21]

Radiant Asymmetry

Radiant asymmetry can also cause discomfort. For example, warm ceiling and cool walls. In Netherlands, the buildings are usually only equipped with heaters to adjust the indoor climate, since the summer here is not so hot in most time. As a result, the radiant asymmetry is more possible to happen in winter or some extreme nights in summer.

Conclusion

Compared with other parameters, these parameters are not so dominant in thermal comfort. However, if we want to check the thermal comfort in a small scale, extra effort in this part can help to further understand the real sensation of the occupants, especially when these problems are found by investigation.

2.2 Thermal Comfort in Existing High Rise Residential Buildings

Though there are many high rise residential buildings constructed all over the world, the thermal comfort level in them was only checked in few of them, most of which were carried out in Southeast Asia.

In Hong Kong, a questionnaire survey was done in a few high rise residences in summer. The results suggested that more than 70% of the respondents felt stuffy because of the poor IAQ, while two thirds of the respondents didn't know that a ventilation switch could be turned on to improve indoor air quality. Lack of knowledge of ventilation control devices was the major problem, indicating an urgent need for user education [23].

In Singapore, a questionnaire survey was carried out by N.H. Wong. It was found that residents in the middle part of the building tend to be more unsatisfied with the thermal comfort, while the residents on the top floor hold a more positive opinion about that. However, a percentage of residents on the top floor held the opinion that the wind was too strong [28]. Though strong wind is usually annoying, it can also become positive factor in such hot climate in Singapore.

In Kuala Lumpur, Malaysia, two high rise dormitory buildings were researched by on-site measurement. This research focused on the special character of a high rise building. It was found that the temperature in the high rise building rises with the

height. The temperature is apparently higher on west side, compared with that on other sides [29].

In Hyderabad, India, the thermal comfort in naturally ventilated apartments was researched for three months in 2008 by Madhavi Indraganti. It was found that adaptive opportunity is vital in thermal sensation. The percentage of subjects who voted comfortable on thermal sensation scale rose from 40% to 94%, when there was adequate chance to adapt the indoor climate. Indian people can adapt well to the climate, when they wear the traditional cloth-lungi, which can be easily adjusted without changing clothes. The air velocity was found to remain at around 0.4 m/s most of the time, as the subjects could control the environment as they want [25].

Unfortunately, similar research focusing on high rise residential building in the Netherlands was not found in literature study. As we know, most of the dwellings here are low rise or houses. Moreover, the summer here is not hot in most of the time, so thermal comfort in summer has not been a prior concern in the past years. However, climate change causes more and more hot days. The average temperature has increased by 1.4°C in the period from 1951 to 2013, and the trend will continue in the following years [30]. The development in building technology also allows people to chase for better living quality in the buildings.

Conclusion

The research about thermal comfort in high rise building is still very limited. According to the previous research, we know that the wind velocity, temperature can change with the height and direction. It is interesting to know the thermal comfort level in the high rise buildings in the Netherlands.

2.3 Principles in Natural Ventilation

2.3.1 Driving Force

The driving force for natural ventilation in a high rise building is the same as in other buildings. Air pressure difference is the basic physical mechanism for air flow, and

pressure difference is generated by the effect of wind and temperature difference (which can lead to buoyancy). Therefore, natural ventilation can be categorized into “wind-induced” and “buoyancy-induced” [4]. In most cases, two driving forces are combined to make the system more reliable.

In most regions, natural ventilation is not capable to provide thermal comfort for a whole year, due to extreme weather in some period. As a consequence, a mixed-mode system is commonly used to serve the residents.

2.3.2 Ventilation Type

There are many parameters affecting the performance of natural ventilation, but the effect weights are not equal. Natural ventilation mode is found to be the most influencing parameter in a high rise residential building, compared with other factors such as window type, window-to-wall ratio, window orientation [31].

Natural ventilation can be categorised by ventilation method. Single-sided ventilation, Cross ventilation and Stack ventilation are the three main categories. In a room with single-side ventilation, air enters and through the opening on the same side it is exhausted from. Cross ventilation relies on the air flow between the two sides of the building, which is usually driven by the air pressure windward and leeward. Stack ventilation involves the entry of fresh air at a low level and its exhaust at a higher level of the building.

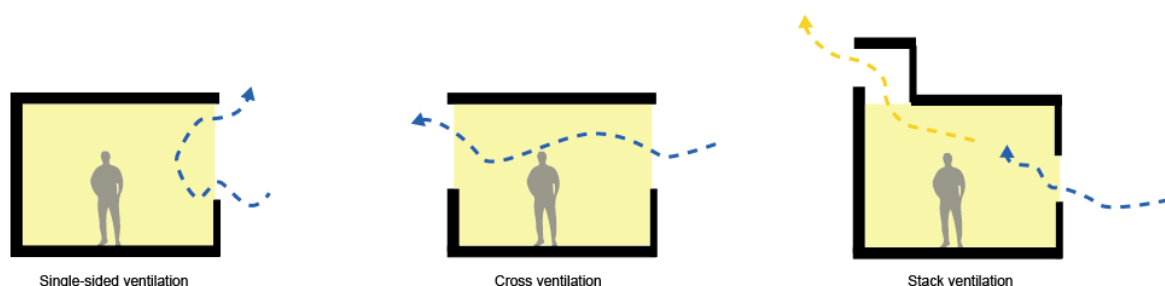

Figure 8: Basic ventilation types

The efficiency of the three modes is different. Cross ventilation usually promises the highest efficiency of natural ventilation, which can provide around 2-5 times the

ventilation rate compared to a single-sided window. Moreover, compared with single-sided system, cross ventilation implies opening sizes 15-20 times smaller for the same rate of ventilation [31][45]. The efficiency of stack effect largely depends on the height of the system.

Natural ventilation can be categorised by the system that is contained. It can be in contingency mode, which means the building is designed to be naturally ventilated, but with possibility to switch to air-condition system or vice versa. It can also be in zoned mode, which means there are different systems in different zones. The last one is complementary mode, which allow both air-condition and natural ventilation to work in the same space. If it is not feasible to rely on natural ventilation solely, the way to combine different systems needs to be considered [4].

2.3.3 Natural Ventilation Potential

Natural ventilation potential can be represented by how much time a building can be naturally ventilated. Thermal comfort and wind pressure are the dominant factors in this issue. Longer natural ventilation period usually leads to higher comfort level and less energy consumption. Although there are already some researches about the natural ventilation potential in different regions, they often show different results.

The efficiency of natural ventilation usually varies in different regions. In European countries, where the climate is temperate, the natural ventilation system can be used in 40% to 80% of the time in a year, which has been proved by a few real projects, such as the Commerzbank in Frankfort and 30 St. Mary Axe in London [4]. Therefore, buildings in Europe are usually equipped with a hybrid system. In hot and humid climate areas, natural ventilation systems usually can be used in 20%-78% of the time in a year [32][33][34]. Real efficiency depends largely on the design.

There are already many basic researches about natural ventilation potential, but only a few of them are based on real project and residents' comfort. Further research about the use of natural ventilation in real building from occupants' comfort perspective is helpful to verify the existing research.

2.3.4 Wind Gradient

Wind velocity and the wind pressure on the building increase by the height. As shown in Figure 9, the wind pressure on top floor of a high rise building can be higher than the wind pressure on the ground floor. As a result, the wind pressure acting on the windows on top floor is also higher, which can lead to higher indoor air velocity.

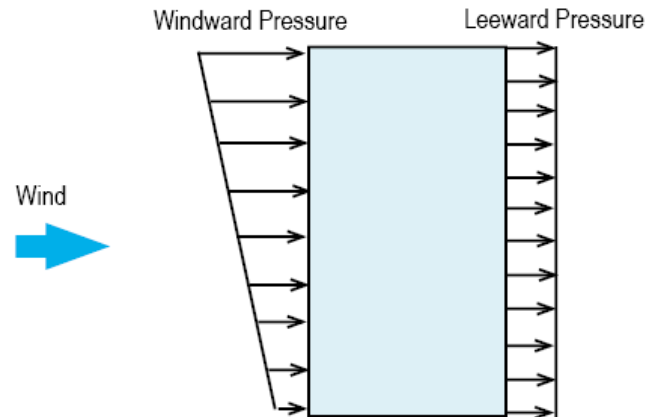

Figure 9: Wind gradient

Wind velocity gradient change follows the function below:

$$v_z = v_{zg} \cdot \left(\frac{z}{z_g} \right)^{\alpha} \cdot b, \quad 0 < z < z_g$$

Where:

v_z = speed of the wind at height z

v_{zg} = gradient wind at gradient height z_g

α = exponential coefficient

b = constant value depending on terrain category ($b = 1.0$ for open terrain category)

Terrain is the surrounding of the building or structure. It shall be assessed on the basis of the following category descriptions [24]:

- Category 1: Exposed open terrain with few or no obstructions and water surfaces at serviceability wind speeds.
- Category 2: Water surfaces, open terrain, grassland with few, well-scattered obstructions having heights generally from 1.5 m to 10m.
- Category 3: Terrain with numerous closely spaced obstructions 3 m to 5 m high, such as

- areas of suburban housing.
- Category 4: Terrain with numerous large, high (10 m to 30 m high) and closely spaced obstructions, such as large city centers and well-developed industrial complexes.

It should be noticed that the air velocity in urban area is usually more complicated due to the city geometry. In most cases, on-site measurements or wind tunnel research is needed to gain the precise air velocity.

2.4 Natural Ventilation Techniques in High Rise building

Natural ventilation is a process of using natural outside air movement and pressure differences to replace the indoor air and cool down the building. In reality, natural system is usually combined with mechanical system to provide more reliability. If we want to apply the criteria of natural ventilation, the residents should be able to adjust the natural system as they want, and the natural system can work independently.

2.4.1 Window

The window, which is the most common way for natural ventilation in residential buildings, provides a good balance in comfort and cost. In most cases, the proportion of windows open is lowest in winter, and highest in summer, which can be shown by a function [37]. According to the research by Raja et al in UK, when the indoor temperature in a naturally ventilated building rises to higher than 27°C, almost 100% of the windows are open. When the temperature is in upper twenties, most people choose to turn on the fans, which is the same in UK and Pakistan. Few windows are open when the outdoor temperature is less than 15 °C [38].

People also have preference about the size of the windows. It is interesting to notice that people prefer to open smaller windows when the temperature increases [39]. Large windows are sometimes not easy to adjust adequately, while small windows have fewer problems in this aspect.

Since the ventilation rate is largely influenced by the occupants, further research about the driving force of occupants' window opening behaviour was developed by Fabi et al [40]. It was shown that type of dwelling (single house or apartment), the orientation of the building and type of the room (bedroom, living room or kitchen) are the main parameters found to affect the occupants' behaviour.

However, sometimes it is necessary to use special windows in a high rise building, due to the high wind velocity. Sudden gale can cause discomfort. Moreover, traditional window on a high rise building make object falling from high altitudes possible, which is very dangerous for the pedestrians nearby. Therefore, the type of window should fit to the surrounding and the building itself.

2.4.1 Ventilation Grills

Ventilation grill is a common ventilation device with many small holes or slots on a board. Air can penetrate the ventilation grill through the holes, while rain and unflavoured breaking in can be avoided. The Netherlands is a country with much rain and wind. Therefore, ventilation grills are very common in the land. Moreover, it is regulated in the Dutch building code (Bouwvesluit) that **(a)** the air velocity at the ventilator should not be more than 0.2m/s **(b)** the residents should be able to adjust the system properly. Ventilation grill is ideal for both of these two requirements.

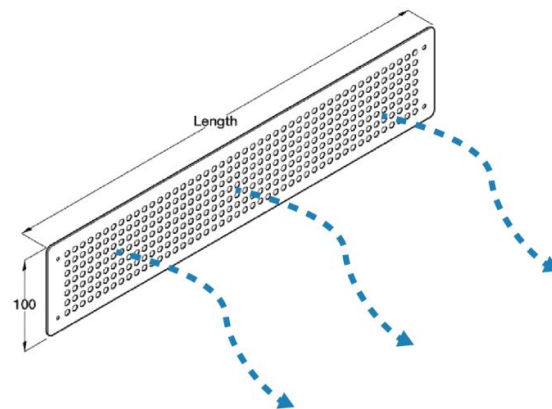

Figure 10: Ventilation grill

Since the size of the holes or slots is very limited, it cannot provide large amount of fresh air. The air velocity penetrating the holes is also limited by the small size. As a result, it is not so efficient in cooling.

2.4.2 Façade System

Façade is the exterior side of a building, which is one of the most significant technologies for energy savings in a building [41]. In modern architecture, it is also called envelope or shell, since they are not integrated into the main structure as before. In a modern high rise building, the façade has direct contact to the outside, which makes it very important in natural ventilation design.

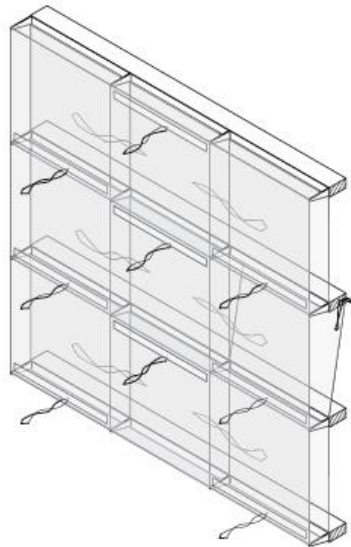

Figure 11: Double façade system

Source: Ulrich Knaack et al, 2007

Double skin façade (DBS) is a growing technology in the past years, which is resulted from the shift of various function related to the interior functions of the building immediately behind the façade [42]. Lots of studies have proved that it can contribute to better comfort and energy efficiency.

For natural ventilation buildings, double skin façade can also plays an important role to improve the indoor comfort level. According to Sabrina and Kenneth, most of the DSF performance researches are carried out in temperate climate [43]. Most of the research is about office buildings, but not so much studies are about high rise residential buildings. Hence, further research about naturally ventilated DSF in

tropical areas and residential buildings is still in early stages.

Climate adaptive façade is a new trend nowadays. To correspond to the climate, the façade can change to some extent to meet the requirements for comfort and energy consumption. On time scale, it can be divided into seconds, Minutes, Hours, Diurnal and Seasons. On physical domains, its function can be classified into four areas: Thermal, optical, air-flow and electrical [44]. Monsoon responding façade can be an effective approach to natural ventilation. According to a responsive façade design of a library building in Korea, the energy consumption for cooling in summer can be reduced by 12% if a monsoon responsive façade is applied [61].

2.4.3 Other Passive Techniques

Apart from the three basic ventilation techniques mentioned above, there are also other wind techniques that can help to naturally ventilate a building or contribute to the indoor thermal comfort. They have specific function, but they need lots of effort and cost to refurbish the building, which is not so practical in such a dormitory building. Therefore they are introduced here briefly to show the possibilities.

Wing Wall:



Figure 12: Menara UMNO

Source: [<http://www.payer.de>]

“Wing wall” is a wall that can guide the wind directions. It is applied in Menara UMNO (by Ken Yeang), which is famous for its green high rise concept. Since the prevailing wind direction is not ideal for natural ventilation, the “wing wall” is designed to change the wind direction nearby the building.

Solar Chimney:

If the driving force for natural ventilation is not enough, some techniques such as solar chimney can be used as a supplement. Solar chimney utilizes the radiation from the sun to heat the air in the solar chimney. Due to the buoyancy, hot air automatically rises to the top of the solar chimney and flow out, which can lead the air flow in the whole building.

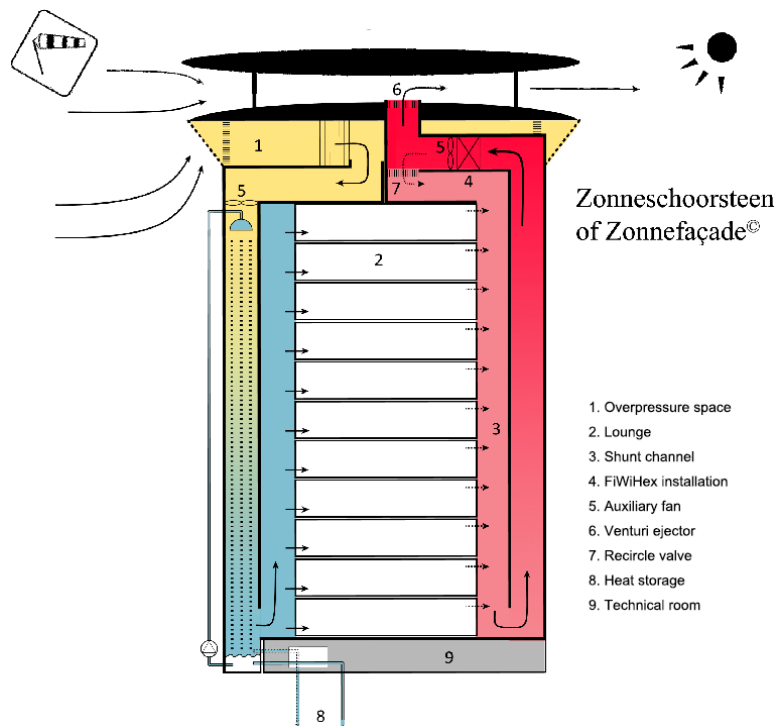

Figure 13: Solar chimney

Source: [<https://bronconsult.org/>]

Extra Supplementary Strategies:

According to Gratia et al, there are several extra passive strategies for improving thermal comfort except natural ventilation [46]:

- Thermal mass effect: Thermal mass can keep the temperature more stable in one day. The temperature of the building with large thermal mass changes very slowly with the

weather change.

- Night ventilation: The temperature at night is usually lower than day time, which is very beneficial for ventilation. Night ventilation is widely used all over the world in summer.
- Passive solar heating: In winter, solar radiation is a good heat source to heat the building.
- Evaporative cooling: When water evaporates, lots of heat is brought away. Evaporative cooling is very effective in hot and dry climate.

When these techniques are combined with natural ventilation system appropriately, the indoor thermal performance can be further improved.

2.5 Conclusion

Natural ventilation has a large potential in energy saving and comfort improving. When the height of residential buildings tends to increase, it is necessary to research on how we can provide natural ventilation for residents there.

Previous researches have already proven that the thermal comfort level in a high rise residential building can differ by height and direction. However, the number of cases is still very limited, and there is not such research done in the Netherlands. To better understand the thermal comfort level in high rise residential buildings in the region, it is valuable to make on-site measurement to check whether it is really comfortable, and find out how we can improve it.

Lots of natural ventilation technologies are available nowadays, but it is still not clear what the appropriate way is to provide natural ventilation in high rise residential buildings. To deal with high wind speed on high altitude and other challenges in high rise buildings, more detailed work is needed to check residents' feeling. After that, we can find out which system is more suitable in this kind of circumstance.

CHAPTER 3. Field Study

In this research, the field study is crucial to assessing the comfort level in a specific building and providing data for the further simulation. The field study consists of two parts: a questionnaire survey and measurements. They are closely related and they were carried out in the same period. With the help of the field study, real and detailed data about the comfort level in a local building can be gained, which is the basis of this research.

In this chapter, a detailed plan of the field study, including building information, survey method parameters, experiment equipment and questionnaire design, shall be explained.

3.1 Building Information

The research is intended to study thermal comfort in a typical naturally ventilated residential high rise building in the Netherlands. Moreover, there should be sufficient interviewees living there, and the residents are expected to be willing to cooperate with the research.



Figure 14: Perspective of Roland Holstlaan(1-749)

Source: [<http://www.tudelft.nl/>]

Roland Holstlaan(1-749), built in 1966, is a 17 floor student dormitory building with 340 studios and 34 two room apartments, which perfectly meets the requirements of the research. The main façades of the building face east and west, but with an 18.5° deviation to the south (counter clockwise). This is shown in Figure 15.



Figure 15: Roland Holstlaan(1-749) on a satellite map

The building has a hybrid ventilation system composed of windows, ventilation grills and mechanical exhaust. The extractors are connected to central exhaust ventilation on the roof, as shown in Figure 16. It is possible to slightly adjust the size of the extractors in the room but that is only accessible by the maintenance staff. The windows and ventilation grills are the only devices that can be controlled by the occupants in the building.



Figure 16: The ventilation exhaust on the roof

Most of the occupants of the building are international students, who only live here 1 or 2 years. Due to historical reasons, there are also a few residents with other backgrounds living in the building, which makes the composition of the residents

complex. Attention should be paid to this, since different backgrounds can cause different perception and expectation and sensation of the environment.



Figure 17: Wall construction 1



Figure 18: Wall construction 2

The main structure of the building is made of steel frame and concrete floors, which has relatively a low thermal mass when compared with traditional brick buildings. The walls are constructed by wooden hollow partition wall and Lime sand stone (Kalkzandsteen) walls, which is kind of typical Dutch building material. Figure 17 and Figure 18 are photos taken in the maintenance room, where the construction of the building is exposed.

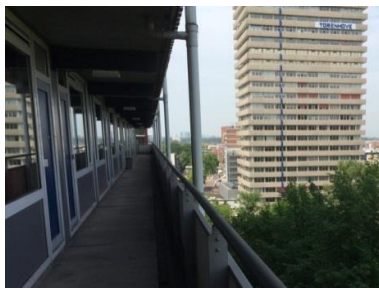

Figure 19: The corridor on the middle floor

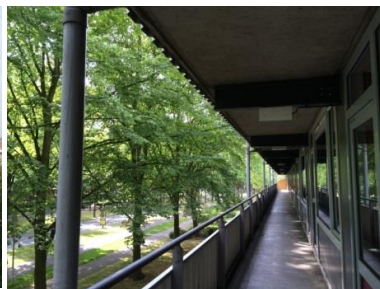

Figure 20: The corridor on the lower floor



Figure 21: The surroundings

The building is perfectly symmetrically arranged. There are corridors on both sides of the building, which face east and west separately. All the rooms are located along the corridors. The only window and door also face the corridor, which can cause privacy problems in reality. The symmetry layout also leads to various indoor climates in different sides of the building. As shown in Figure 19, the top floors are exposed to

the sunshine directly, which can gain more heat from the sun. As shown in Figure 20, the rooms below the 11th floor are shaded by tall trees, which might cause reduction of sunlight. On the ground there are lots of trees as shown in Figure 21.



Figure 22: Photo in one room in the building

Source: [<http://www.tudelft.nl/>]

Figure 22 shows the interior of one room. The layout of the room is regular and compact. Figure 23 is a 3D model of the room. It can be seen from the graph that the room is around 20m² large in total. The kitchen, the toilet (containing the bathroom) and the living room are compactly arranged together. A tiny room in the right side of the model is a lobby to place the shoes and coats. Since it is usually separated from the living room by a door, it is excluded from the simulation model in this research. Along the corridor are the ventilation grill and window, which are the only operable parts for the occupants.

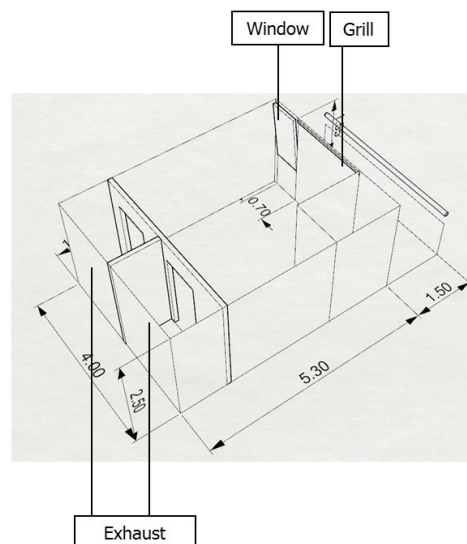

Figure 23: A room 3D model

3.2 Local Climate

According to Köppen climate classification, the climate in the Netherlands is typical *temperate maritime climate*, influenced by the North Sea and Atlantic Ocean, with cool summers and moderate winters. The full-day average temperature in winter is around 2°C -5 °C, and the average temperature in the summer is approximately 17°C - 20 °C. However, the average maximum temperature in summer is higher than 22°C and an extreme temperature of higher than 38°C was recorded.

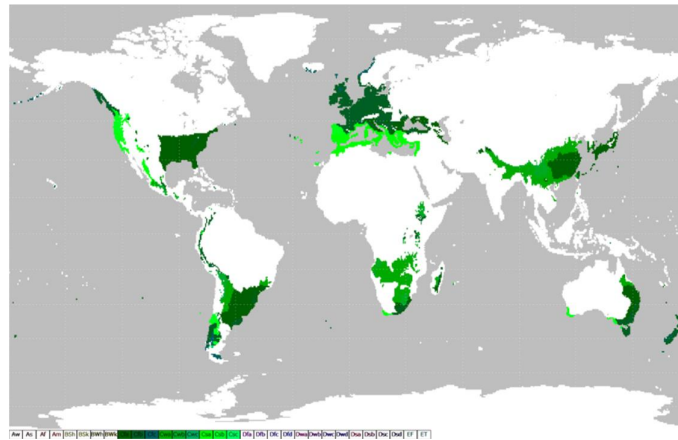

Figure 24: Köppen climate classification

Source: [<https://nl.wikipedia.org/>]

As shown in Figure 25 and Figure 26, the prevailing wind direction in Rotterdam in the summer seasons is southwest. The data is collected only 5km away from the studied building, so it can be directly used here. Most of the time, the wind velocity is between 3-4 Bft, which is equal to 3.4-7.9m/s. This is regarded as gentle breeze.

Windroos Rotterdam, klimatologie juli

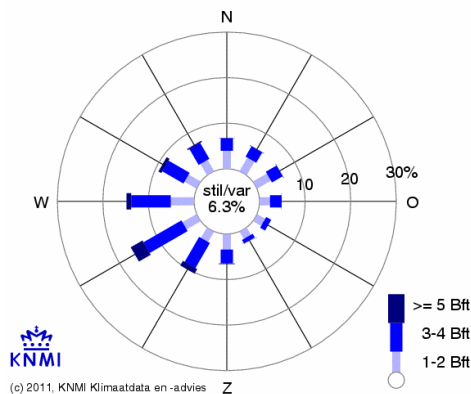

Figure 25: Wind Rose Rotterdam, July

Windroos Rotterdam, klimatologie augustus

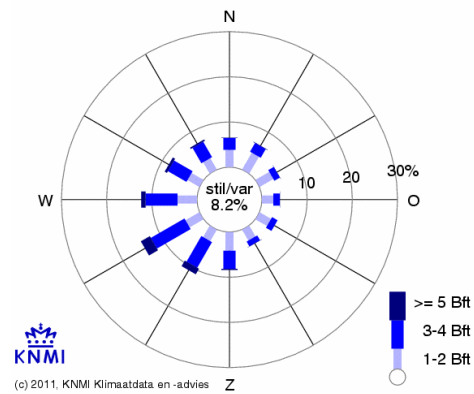

Figure 26: Wind Rose Rotterdam, August

Source: [<http://www.knmi.nl>]

As mentioned in section 2.1.2, the Running mean outdoor temperature (RMOT) Θ_{rm} should be derived from the outdoor temperature. The climate data is collected from the Netherlands Meteorology Institute website [<http://www.knmi.nl/>]. Based on the formula in Section 2.1.2 and the climate data, we can calculate the Running mean outdoor temperature Θ_{rm} for each day in the experimental period. The temperature in these days and corresponding results are shown in Table 3 below.

Table 3: Mean outdoor temperature and corresponding Running mean temperature + Comfort limits

Date	Mean outdoor temperature	Θ_{rm}	$\Theta_{o,l,min}$ minimum	$\Theta_{o,l,max}$ maximum
20150623	12.8			
20150624	16.3			
20150625	18.1			
20150626	20.3			
20150627	17.4			
20150628	18.6			
20150629	18			
20150630	21.6			
20150701	27	15.1	19.0	25.083
20150702	24	16.8	20.0	26.772
20150703	23.3	17.5	20.4	27.340
20150704	23.9	17.8	20.5	27.569
20150705	19.6	18.3	20.6	27.675
20150706	18.3	17.8	20.7	27.840
20150707	19.4	17.1	20.6	27.668
20150708	16.2	16.7	20.4	27.453
20150709	13.9	15.4	20.3	27.304
20150710	18.1	14.1	20.1	26.896
20150711	20.4	13.9	19.8	26.458
20150712	17.8	14.2	19.8	26.397
20150713	17.5	14.1	19.8	26.493
20150714	17.9	14.0	19.8	26.457
20150715	17.7	14.0	19.8	26.427
20150716	19.2	14.1	19.8	26.413

The maximum running outdoor temperature $\Theta_{o,l,max}$ and minimum running outdoor temperature $\Theta_{o,l,min}$ define the comfort zone in this period, which is shown in Figure 27.

The comfort zone graph can be combined with the real temperature variation curve to show whether the indoor temperature is satisfying. The comparison of the comfort zone and real temperature are introduced in section 5.2.1.

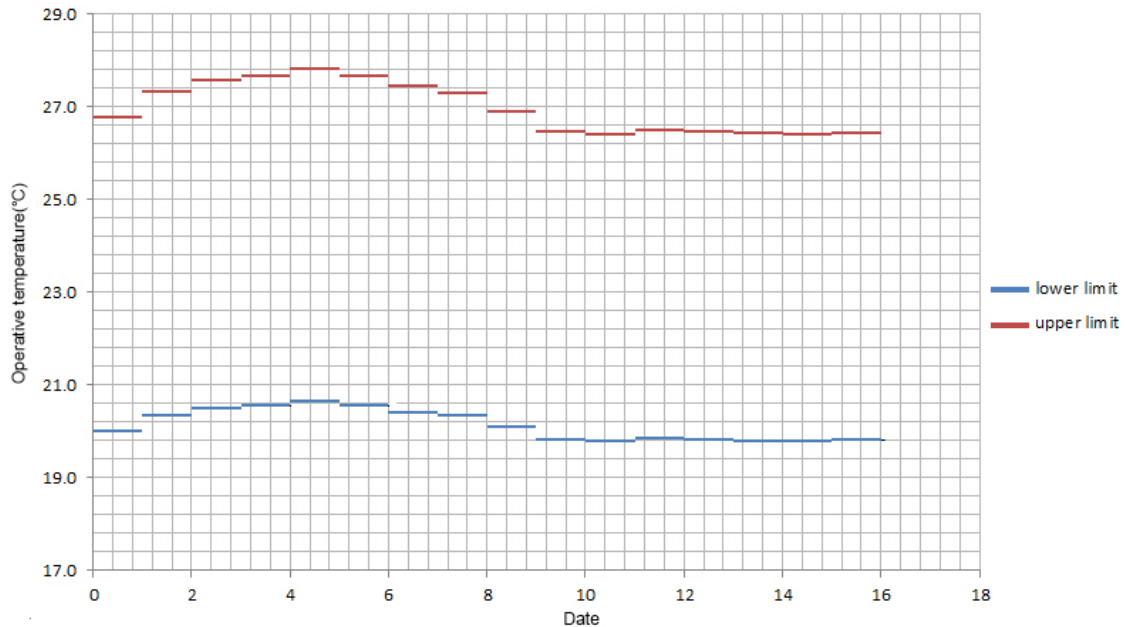

Figure 27: Comfort zone in experimental period

3.3 Parameters

The measured parameters can be divided into physical parameters and subjective parameters. Physical parameters are measured by equipment or gained from the local meteorology station.

Important Physical Variables Measured On Site

To assess the indoor thermal comfort, three most crucial parameters are chosen to be measured on site.

- Operative temperature (T_o) [°C]
- Air velocity (V_{air}) [m/s]
- Relative Humidity(ϕ) [%]

Compared with air temperature and radiant temperature, the operative temperature is more commonly used in standards, such as ASHRAE 55 and NEN-EN 15251, and it is also more practical to be measured. As a consequence, operative temperature will be measured instead of air temperature and radiant temperature in this research. In most standards, relative humidity is chosen as the criterion instead of vapour pressure. Humidity can be measured directly by the sensors. Air velocity is measured by a handheld hot-wire air velocity meter, which cannot measure vector but scalar quantity. Consequently, the air velocity will be measured in 10 minutes to get an average value, which can help to reduce inaccuracy.

Physical Variables Gained From meteorology station

Since the meteorology station can provide more precise local climate data, there are four important parameters selected to be gained from the meteorology station directly.

- Solar radiation [W/m²]
- Air temperature(T_{out}) [°C]
- Wind velocity (V_{wind}) [m/s]
- Wind direction (0-360) [°]
- Relative Humidity(ϕ) [%]

Due to limited availability of equipment, it is not possible to measure all these parameters continuously on site. Therefore, local climate data will be gained from the meteorological station in Rotterdam. There is always deviation between the on-site data and the data from the meteorology station since different circumstance can affect the micro-climate. However, the difference is acceptable in just 5 km distance.

The basic parameters--air temperature, relative humidity and wind velocity, are undoubtedly needed to be compared with the indoor environment. Except from the basic parameters, solar radiation and wind direction are also required. Solar radiation can help to assess the heat gained by the building.

Subjective Perception and Residents Behaviour

Apart from the objective measurement, subjective perception of the residents and their behaviour are also important in the thermal comfort assessment. These will be studied by a questionnaire survey.

Subjective sensation consists of a series of different parameters. It plays an important role to assess the thermal comfort level from the residents' perspective, which can also help to avoid error in the measurement. Since thermal comfort is the main focus of this research, thermal sensation is definitely the most important issue. Questions investigate the thermal sensation on a 7 point ASHRAE-scale: -3, -2, -1, 0, +1, +2 and +3 (cold, cool, slightly cool, neutral, slightly warm, warm, and hot) in both summer and winter. To make the layout of the questionnaire clear and in order, the 7-point scale is also applied in many other questions, which can reduce the time needed for the interviewees to understand the questions.

Residents' behaviour can also make difference in thermal comfort assessment. For example, whether the window is open, the status of the fan, whether air-conditioner is turned on, and the frequency of sports. All these parameters can lead to residents' different perception to the same weather. Some of these variables can be observed by the interviewer directly, but asking the occupants to verify the observation can make the results more reliable.

Not only the residents' thermal perception, but also other aspects, such as noise level and privacy issue were studied. Although these parameters are not directly related to thermal comfort, they still affect residents' degree of satisfaction. Only considering the thermal comfort without any consideration to other aspects might lead to a final design which is bad in other disciplines.

3.4 Instruments

In this section, all the instruments used in the measurement are introduced. Figure 28 is a photo of the equipment collected in the toolbox.



Figure 28: The equipment used in the measurement

Table 4 is a list of the instruments and their detailed information. To measure the three most important parameters—temperature, humidity and air velocity on site, four different types of sensors are chosen. As there were not enough “iButtons(thermal&humidity)” available, 4 “Escort Juniors-Thermal&Humidity meter” are added as supplement to measure the humidity.

Table 4: Equipment list

Name	Model	quantity	Resolution	Accuracy
iButton(thermal&humidity))	DS1923	1	0.0625°C	±0.5°C
iButton(thermal)	DS1921H	32	0.0625°C	±0.5°C
Air velocity meter	Extech SDL350 CFM	1	0.01m/s	±5%rdg
Thermal&humidity Data Logger	Escort Juniors EJ-HS-B	4	0.3°C 0.5% RH	± 3%

The iButton is a micro sensor around 1.5cm² large, which can be easily stucked on any surface or object. It can record the data continuously for 14 days with an interval of 10 minutes, so it is necessary to replace them during the experimental period. There are two kinds of iButtons: Thermal iButton and thermal&humidity iButton. Thermal

iButton can only record temperatures, while thermal&humidity iButton can record both temperature and humidity.



Figure 29: iButton

Source: [<https://www.maximintegrated.com/>]

The “Escort Juniors” thermal&humidity Data Logger is a relatively larger sensor with a diameter of 7 cm. It can be installed in a room to measure the humidity and operative temperature. However, the resident complained about the noise caused by this equipment after the Data Logger had been installed. Every ten minutes, the indicator shines and the sensor makes a sound, which is annoying especially at night. As a result, except the one had been installed, no more of this type of sensor was used.



Figure 30: “Escort Juniors” Thermal&Humidity Data Logger

Source: [<http://www.polylam.com/>]

The “Extech SDL350 CFM” Hot Wire CFM Thermo-Anemometer is a handheld multi-functional sensor that can measure temperature, humidity and air velocity. A hot wire air velocity sensor can only measure the velocity but not the direction. Since the wind direction is unknown and changing, the preciseness of the measurement might be affected. In this research, the instrument is only used to measure the air velocity.



Figure 31: Hot Wire CFM Thermo-Anemometer

Source: [<http://www.extech.com>]

3.5 Questionnaire Design

The questionnaire survey plays an important role to reflect residents' feeling and subjective opinion, which is difficult to be measured by equipment. The questionnaire is preferred to be as compact as possible, since people might lose patience if it is too long. The final questionnaire is designed to be a 7-minute long questionnaire. However, the real time that the residents need to finish it differs a lot. Some interviewees had not finished the questionnaire, fifteen minutes after the questionnaire had been handed in to them.

The questionnaire in this research is designed based on the indoor comfort questionnaire by Professor Bluysen[51]. Based on the research questions of this research, some specific questions are added and unrelated questions are deleted to make the questionnaire more compact and targeted. The full questionnaire can found in Appendix A.

To make it easier to process the data and more clear for the interviewees, the questionnaire is divided into 5 main parts:

- *Personal Information:* Basic personal information, such as nationality and floor, is asked to be answered in the first part. Compared with the questions in other parts, the questions in this part are relatively easy, which is friendly to the interviewees.
- *Lifestyle:* This part focuses on the lifestyle of the residents. It is intended to assess whether the lifestyle might affect the comfort level.

- *Systems and Activities*: Questions in this part focus on the system of the building and how the residents control it. It can help the researchers to know the equipment in the residents' room. For example, an extra heater or a fan bought by themselves.
- *Humidity*: Humidity is separated from the comfort part, because the questions are not in a 7-point scale, and there are also questions about how they hang their clothes after washing.
- *Comfort*: This part is the most important part in the questionnaire. A series of questions about comfort in different seasons and different aspects are asked here. In this part, a 7-point scale is applied in most of the questions, which makes it easier for the interviewees to fill it in.
- *Remarks*: Apart from the questions that are offered, there might be extra information that the interviewees would like to mention. This part is to provide such a chance for them.

3.6 Field Survey Procedures

The field study is made up of 2 parts: a measurement and questionnaire survey. Since they are closely related and carried out at the same time, they will be introduced in this section together.

3.6.1 Survey Period

The measurements were expected to be carried out in two weeks in July or August, which is summer in the northern hemisphere. Finally, it was done from 1st July to 16th July in 2015.

Summer days with a high risk of discomfort are preferred to provide more summer data. Since the weather in the Netherlands is changeable and unstable, weather forecast plays an important role in choosing the data. The temperature on 1st July reached 35°C in the afternoon, which is quite rare in Netherlands. Hence the experiment starts from that day.

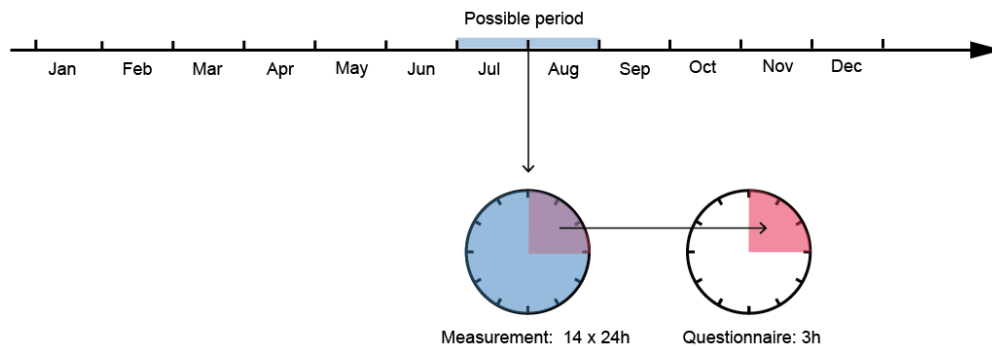

Figure 32: Experiment time period

The measurements lasted 2 weeks to get sufficient variation in temperature and climate. The questionnaires were delivered at the same time each day, because people interviewed in the morning and in the afternoon might have different reactions.

3.6.2 Survey Process

The survey process can be divided into 4 parts: *Residents interview*, *Instrument set-up*, *Data collecting* and *data analysis*. They were carried out in the same order as in the survey process.

(1) Residents Interview

There are more than 380 rooms in the building in Roland Holstlaan, while only 305 of them have the same layout. Different layouts of the rooms will probably lead to different comfort levels. To avoid this predictable error, only the 305 typical rooms are visited.

The interview of the residents is intended not only for the questionnaire survey, but also for permission to install sensors in the residents' rooms. Therefore, it is necessary to ask whether the occupants would like to accept a sensor in their room, when the questionnaire is delivered. Another prerequisite is that they would live in this room in the following two weeks. Since it was already summer vacation, it further reduced the number of possible interviewees.

Each questionnaire is expected to be finished by the interviewee in around 7 minutes (3 minutes for explanation not included). Since the residents live in different rooms, it is not possible to explain the purpose and the survey to all of them at the same time. Therefore, the residents were interviewed one by one. This also offered the researcher a chance to really talk with the interviewees and observe the thermal comfort situation in their rooms.

To provide useful amount of information, 20 subjects are the minimum sample size [16]. Finally, all the rooms were visited, and 96 effective questionnaires were gained.

(2) Instrument Set-up

Measuring physical variables are the main aim of the measurement. The measurements were carried out in specific rooms of the building and in some points on the corridor.

All the equipment needs to be ready before the measurement. Before visiting the residents, all the sensors are programmed to start measurement after the visiting, which can guarantee the correctness of the data.

The rooms to be measured should be well distributed. Since the researchers can only visit the residents one by one and ask for their permission, it is not possible to arrange all the measured rooms in advance. Furthermore, the residents should live in the room for most of the experimental period, which is essential for the concept of a “naturally ventilated room”. In reality, we tried to find out the suitable rooms following one the following situation:

- *Rooms on the same side and same floor:* Rooms on same floor and same side have a minimum difference. However, there still is a possible difference caused by solar radiation in different times of one day. The aim of this comparison is to check whether there are apparent difference among the rooms on the same floor and the same side.
- *Rooms on the same side but on different floors:* Height is a vital parameter in a high rise building. Air velocity and solar radiation can vary by the height. Therefore it is valuable to compare different rooms on different heights, from the ground floor to the top floor.

- *Rooms on a different side but on the same floor:* Obviously, solar radiation on different façades of the building is different due to the sun path. Its influence on the thermal comfort can be assessed in the comparison.

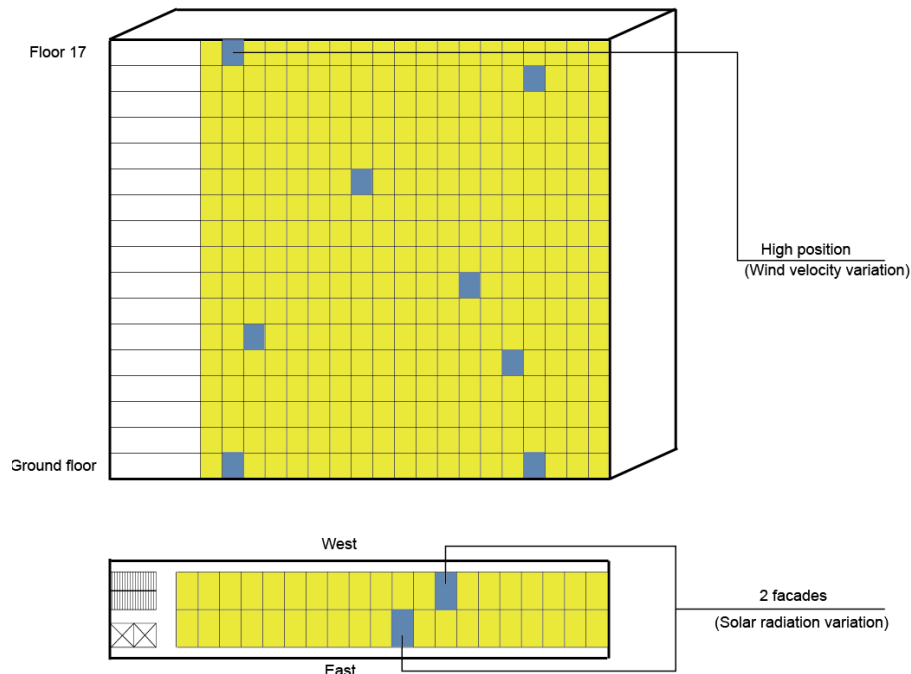

Figure 33: The diagram for the distribution of the measured rooms'

Measurement points on the corridors:

The air velocity was measured on the corridors to check whether the air velocity varies with the height in such a high rise building. There are 6 measure points for this measurement, as shown below:

- 17th floor East
- 9th floor East
- 1th floor East
- 17th floor West
- 9th floor West
- 1th floor West

On each side, there were three measure points on different height, varying from the 1st floor to the top floor. The ground floor is not included, because the layout there is completely different.



Figure 34: Wind velocity measurement on the corridor

Measurement points in the room:

There should be measurement points at the main inlet and outlet, and at different parts in the studio. Two sensors are installed in the toilet and kitchen to assess whether there is temperature difference there. In the living room (bedroom), there is one humidity and temperature sensor on 1.5m height, close to the desk. Next to this is another temperature sensor to measure the wall temperature, so it is installed in the reversed direction. On the ground there is one sensor to measure the floor temperature. The last sensor is installed close to the ventilation grill, which can provide the data for the inlet air temperature. One air velocity meter is set up in the middle of the room to assess the indoor air velocity. In Figure 35, all the measure points are showed in a floor plan and a cross section.

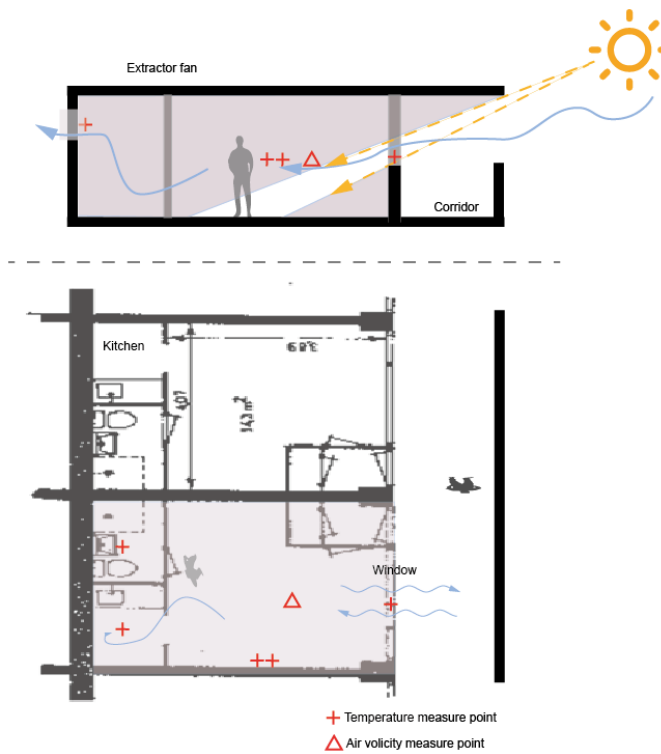

Figure 35: Measure points locations

Since there are not so many sensors available, a detailed measurement is only carried out in several rooms. For the other rooms, only one temperature sensor is installed in the living room on 1.5m height, close to the desk.

How the equipment is fixed is showed in Figure 36 and Figure 37. The iButtons are so small that they can be easily fixed on any surface by tape. The air velocity meter has a long measuring bar, which can extend to 1.5m long. Therefore it can reach any corner of the room without difficulty. The air velocity meter is held by the researcher. It is installed in the centre of the room for a 10-minutes measurement when the interviewee is filling in the questionnaire.



Figure 36: Fixed ibutton



Figure 37: Fixed air velocity meter

(3) Data Collecting

The data can be collected automatically by the sensors. However, the memory capacity of the sensor is only enough for 14 days with a 10-minute interval. Some sensors were installed before 1st of July, so they had to be refreshed in the experimental period. Touching the sensors by hand will definitely change the temperature gained. Therefore, this kind of outliers should be rejected in data processing in a later stage.

(4) Data analysis

The results of the questionnaires were analysed in a statistical way. SPSS and Excel are simultaneously used to process the data. Satisfaction rate, the main complaints, the gender, the age and other related parameters are analysed in this stage. In total, more than 80 parameters can be derived from the questionnaires.

The on-site measured data is the basis for the thermal comfort analysis and CFD simulation model. For the thermal comfort analysis, the data is also processed by SPSS and Excel, like with the questionnaire. The data for CFD simulations were derived from the on-site measurement and analysed to gain suitable boundary conditions.

Detailed data analysis and results are explained in Chapter5.

3.7 Survey Basic Results

The basic information of the survey, such as the number of the interviewees, are analysed in this section.

In this building, the layouts of 305 rooms are the same. Therefore the questionnaires are delivered in these rooms. In total, 96 effective questionnaires were gained in total, which accounts for 31% of the total number.

As shown in Figure 38, around 1/3 of the interviewees were female, which is very similar to the gender distribution of the TUDelft Msc students. This can validate the randomness of the survey.

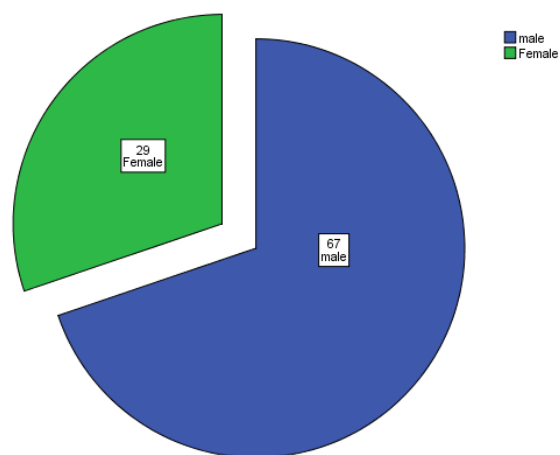

Figure 38: Gender distribution of the residents

Most residents in this building are young students or researchers in Delft University of Technology (TU Delft), but there are also people with other backgrounds. From Figure 39, we can find that most interviewees' ages range from 22 to 26, which is a typical master student age range. There are also some people who are younger or older. They are bachelor students or the original residents who have been here for decades.

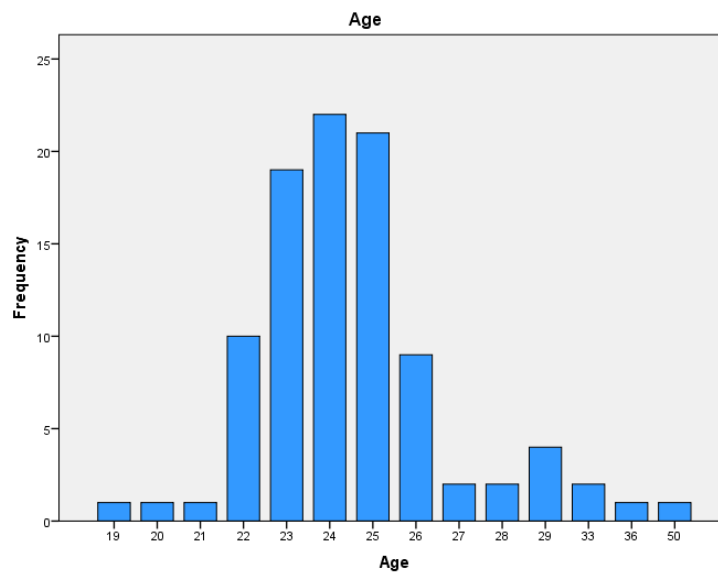

Figure 39: Age distribution of the residents

The nationalities of the residents differ a lot. As shown in Figure 40, approximately 70% of the interviewees come from India, China and Greece. They compose the majority in the building. It seems that the percentage of the Indian students in this building is much higher than the percentage of the Indian students in TUDelft. According to the discussion with the students, it is found that many people from the same country would like to choose the same building when choosing dormitory. This might be the cause of the phenomenon.

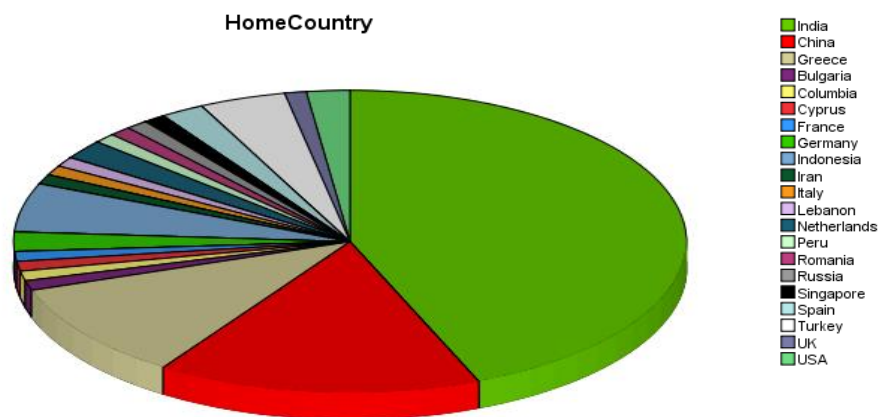

Figure 40: Nationality distribution of the residents

According to the analysis above, the reliability of the survey can be confirmed to some extent. The nationality distribution of the interviewees can make a difference in their thermal sensation, and this will be further analysed in Section 5.2.1.

CHAPTER 4. Simulation Model

4.1 Model information

The CFD simulation model can help us to understand the indoor airflow and the temperature distribution. The model for this research is built with FLUENT 14.5 in ANSYS workbench, which is one of the best CFD simulation softwares at present.

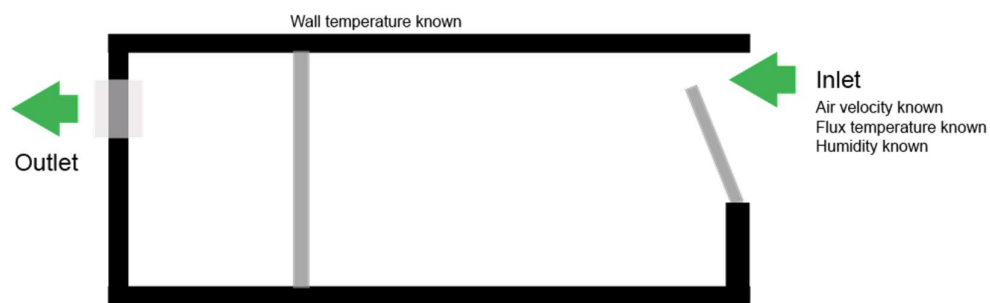

Figure 41: Diagram for the CFD model

To simulate the model in CFD software, the researched room needs to be simplified and modelled. As shown in Figure 41, the room is regarded as a continuous space with inlets and outlets in the CFD model, which has specific boundary condition. A typical room in the researched building can be simplified as a space made up of several boxes, as shown in Figure 42. The size of the “boxes” was measured directly on site.

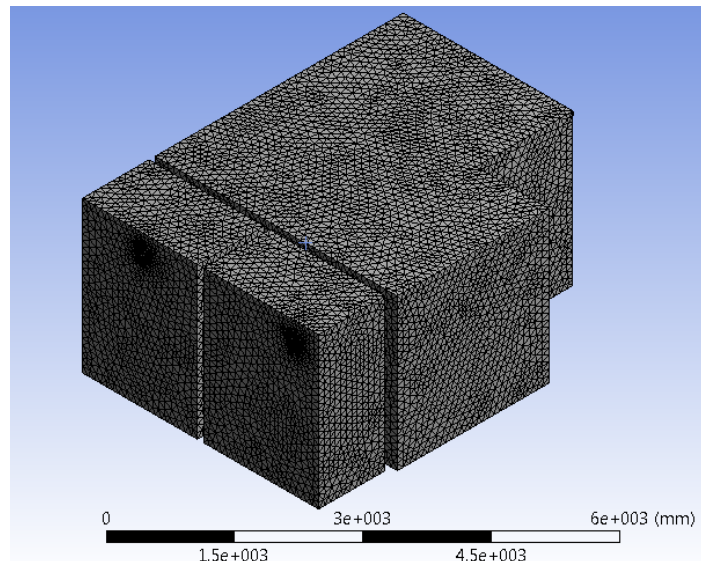

Figure 42: Mesh of the CFD model

Figure 42 shows the CFD model with mesh. The mesh close to the window, the grill and the extractors is more dense, because the sizes of these holes are even smaller than the common mesh size. For the rest part of the mesh, it is regularly distributed since there is no other special irregularity in the room.

There are two extractors located in toilet and kitchen. Since they keep extracting air out of the room, they are regarded as outlets in this model. The window and ventilation grill can be inlet or outlet in different cases, which depends on how the whole system is set.

The air velocity at the extractor was measured directly on site in a 10-minute period, which can guarantee the correctness. The velocity of the natural wind is set to be 1.2m/s, which is also gained from the measurements in a typical summer day. And the wind temperature is assumed to be 25°C. The wall temperature is set to be 30 °C, which can simulate the really hot situation in summer. Since it is a transient state model, solar radiation is neglected in this condition.

To realize the simulation with a relatively limited software version, the model is simplified based on some basic theories. There are 3 different models built for the simulation. The main differences are the boundary conditions and the status of the window. Table 5 shows the boundary conditions of the 3 cases in general.

Table 5: Boundary conditions of different cases

	Case 1	Case 2	Case 3
Ventilation Grill	Inlet	Unknown	Unknown
	Unknown	Unknown	Unknown
Extractor	Outlet	Outlet	Outlet
	4.3m/s	4.3m/s	4.3m/s
Window	-	Inlet + Outlet	Inlet + Outlet
		1.2m/s ;25 °C	1.2m/s ;25 °C
Wall	30 °C		

The extractors are not controllable, at least the residents there don't know how to adjust it. Therefore the extractors are set to be constant open. Based on the on-site measurement, the air velocity at the extractors is approximately 4.3m/s, which is used in the simulation.

The ventilation grill is also set to be open in 3 cases in the simulation. There must be at least one inlet in the CFD simulation. In reality, there is still infiltration ventilation existing, if all the controllable openings are closed. However, that is not the focus of this research, and that cannot provide sufficient air flow to create thermal comfort. Therefore, only the ventilation grill can be set as inlet in the CFD simulation, when the window is closed.

Moreover, "open" is the most status of the ventilation grill. According to the questionnaire, 68% of the residents set the ventilation grill open when they ventilating their room, which is also verified by the observation of the researcher.

Consequently, window is the main variable in this simulation. The details and how the model is simplified are explained separately below:

Case 1: EXTRACTOR (open) + GRILL (open) + WINDOW (Closed)

In Case 1, the extractors and the ventilation grills are open, while the window is closed. Figure 43 shows how it looks like from the corridor.



Figure 43: Closed window

As mentioned before, the extractor is a constant outlet with an air velocity of 4.3m/s. The ventilation grill work as a pressure inlet. The air always come into the room from it, while the air is extracted through the extractor. Therefore the air velocity at the grill can be easily calculated, since the outflow it already known.

Case2: EXTRACTOR (open) + GRILL (open) + WINDOW (Open from the bottom)

In Case 2, the extractors and the ventilation grills are open, and the window is open from the bottom. Figure 44 shows how it looks like from the corridor.

When the window is opened from the bottom, it can only provide a limited amount of fresh air since it is not very large. However, this is still the most common way for the residents to ventilate the room, because this way of opening the window can avoid some safety and privacy problems, such as breaking in and spying.



Figure 44: Window open from the bottom

To simulate the natural situation, the window itself is divided into 3 parts: 2 side parts and 1 top part. Due to the buoyancy, cold air drops and hot air rise up. As a

consequence, the wind usually flows into the room from the side parts of the window, and the top part is regarded as a outlet, where the air pressure is 0.

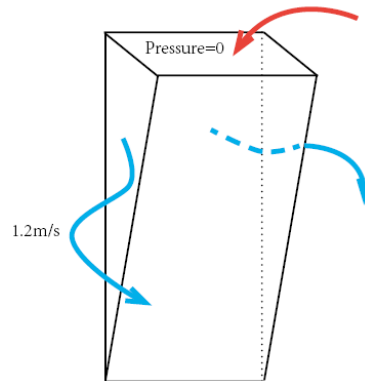

Figure 45: Simplification of the window

Case3: EXTRACTOR (open) + GRILL (open) + WINDOW (Open from the side)

In Case 3, the extractors and the ventilation grills are open, and the window is open from the side. Figure 46 shows how it looks like from inside.



Figure 46: Window open from the side

When window is open from the side, maximum ventilation can be realized. The window can be opened with any angle in reality. However, only when the window is opened mamimumly or completely closed, it is stable. Therefore, the window is assumed to be completely open in Case 3.

In this case, the wdin pattern is more similar to a single-sided ventilation, because the air replaced the extractor is much less than that by the natural wind. Since the window is completely open, it can be regared as a whole. As shown inFigure 47, the

air pressure and velocity is gradedly distributed in reality. In the model, to realize that with limited software capacity, the distribution is simplified as the right graph.

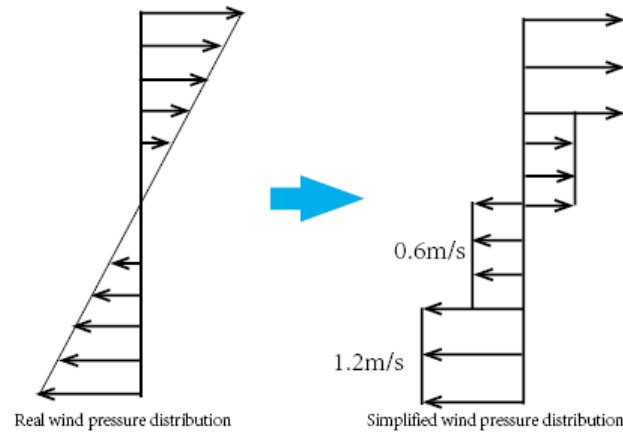

Figure 47: Principle of the simplification

4.2 Accuracy Analysis

CFD simulation is one kind of FEM (Finite Element Method) calculation method to simulate real fluid on a computer. According to previous researchers' experience and comparison, there is always difference between reality and simulation. To assess the validity of the simulation in the research, the reasons of accuracy are analysed in this section.

(1) Inaccuracy caused by simplification

The most accurate way for natural ventilation simulation is to build a wind tunnel in CFD software and put the building in it. That kind of model is usually on an urban scale (1000m), while the scale of the ventilation grill and window is on a much smaller scale (0.01m). If it is expected to simulate precisely in that way, a huge number of cells is needed. The software and hardware condition are not able to support us to do such huge calculation, so a less but acceptably precise method is chosen.

The furniture and residents themselves have volume, which can affect the path of the air flow. In the simulation, the room is assumed to be an empty one without any furniture. Fewer obstructions in the rooms allow the wind to flow more freely, and this might result in higher air velocity in the simulation result.

(2) ANSYS Fluent student version

The simulation quality is hindered because the Student version only allows a certain limit (512,000) in cell numbers when wanting to refine the meshing, which can greatly affect the calculations. Finally, the Elements number for our model is 465136, which is almost the maximum we can utilize in the simulation. Since more cell numbers are possible, the mesh quality is also affected.

(3) Mesh quality

Since the number of cells is limited, it is not possible for us to have the finest cells in all the parts of the model. Therefore the cells cannot be so uniform in the parts close to the extractors and grills, where the size of the cells changes greatly.

The mesh used in the model had various irregularities, resulting in asymmetric model during the simulations. With a limited time to understand the program and content, the mesh was built with the simplest method using ANSYS Workbench, which made it difficult to refine the mesh more elegantly.

(3)Quantity of iterations:

For the calculations 300 iterations were performed, however, more iteration would allow a more accurate result. As shown in Figure 48, the Residual decreases sharply from iteration 1 to iteration 200, and then it keeps decreasing but with a very slow speed. Since the scaled residential doesn't vary drastically after 600 iterations, perhaps more times in iterations are not necessary. It is important to note, that whilst more iterations may produce a better visual result, this is also a lot more time-consuming. As the model is to verify the measurement, the number of iterations here is acceptable.

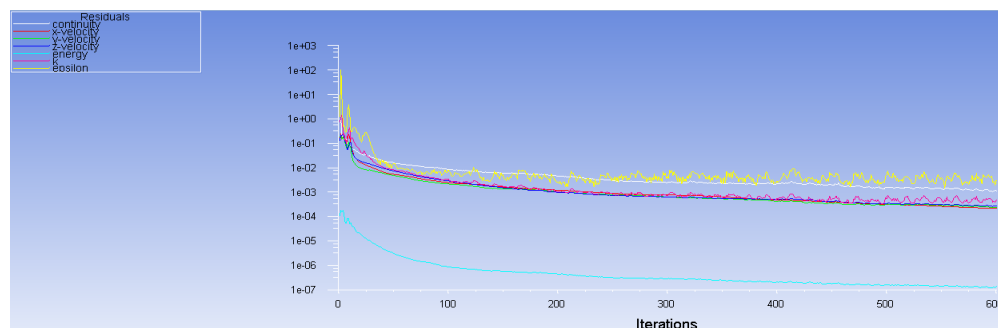

Figure 48: Residuals graph of the simulation

CHAPTER 5. Results Analysis

The field study results and simulation results are closely related, and they can verify each other. Therefore they are combined in this chapter and redivided into 3 sections:

- *General Comfort Analysis*
- *Building Scale Analysis*
- *Room Scale Analysis*

General Comfort Analysis focuses on the comfort level from a more general perspective. Not only thermal comfort, but also other aspects of comfort are analysed together in this section. Building Scale Analysis and Room Scale Analysis are dealing with specific thermal comfort analysis. Building scale Analysis investigates the difference among different parts of the building, while more attention is paid to the thermal comfort of the residents themselves in Room Scale Analysis.

5.1 General Comfort

Overall Comfort Level

The comfort level is determined by many factors, including objective ones and subjective ones. Thermal comfort is however the main focus of this research.

Comfort Overall in summer								
	1	2	3	4	5	6	7	
Unsatisfactory	<input type="checkbox"/>	<input type="checkbox"/>	<input type="checkbox"/>	<input type="checkbox"/>	<input type="checkbox"/>	<input type="checkbox"/>	<input type="checkbox"/>	Satisfactory

To begin with, how do the occupants feel in this building? The question above was mentioned in the questionnaire. On a 7-point scale, 1 means dissatisfied and 7 means satisfied. From Table 6, it can be found that the general comfort level in winter was around 4.7, while that in summer was only around 3.1. It is obvious that residents are more dissatisfied in summer. The standard deviation ranges from 1.5 to 1.9

Table 6: Statistic results of general comfort classified by gender

Comfort Overall in summer				Comfort Overall in winter			
Gender	Mean	N	Std. Deviation	Gender	Mean	N	Std. Deviation
male	3.18	66	1.568	male	4.78	64	1.647
Female	3.04	28	1.856	Female	4.63	27	1.523
Total	3.14	94	1.650	Total	4.74	91	1.604

There is also a subtle difference between genders. No matter in winter or summer, women always graded the comfort level lower. In winter, the difference is even larger than in summer.

Temperature in summer								
Too cold	<input type="checkbox"/>	<input type="checkbox"/>	<input type="checkbox"/>	<input type="checkbox"/>	<input type="checkbox"/>	<input type="checkbox"/>	<input type="checkbox"/>	Too hot

Apart from general comfort, thermal comfort might also differ by gender. The question above was mentioned in the questionnaire to assess the subjective thermal comfort for the residents.

Table 7: Statistic results of thermal comfort classified by gender

Thermal Comfort in summer				Thermal Comfort in winter			
Gender	Mean	N	Std. Deviation	Gender	Mean	N	Std. Deviation
male	5.94	66	0.959	male	3.52	64	1.260
Female	5.50	28	1.291	Female	3.46	27	1.170
Total	5.81	94	1.080	Total	3.50	91	1.227

In summer, the mean thermal comfort vote for men was 5.94, while that for women was 5.50. The standard deviations were 0.959 and 1.291 respectively. In winter, the mean thermal comfort vote for males was 3.52, while that for females was 3.46. The standard deviations are 0.260 and 1.170 respectively.

Table 8: Independent Samples Test of PMV in summer

		Levene's Test for Equality of Variances		t-test for Equality of Means						
		F	Sig.	t	df	Sig. (2-tailed)	Mean Difference	Std. Error Difference	95% Confidence Interval of the Difference	
									Lower	Upper
Temperature in summer	Equal variances assumed	6.905	.010	1.826	92	.071	.439	.241	-.039	.917
	Equal variances not assumed			1.621	40.201	.113	.439	.271	-.108	.987

As shown in Table 8, an independent-samples t-test was used to check the thermal comfort in males and females in the researched building in summer. Since Sig. (2-tailed) value is greater than 0.05, it can be concluded that there is no statistically significant difference in winter thermal comfort for male and female cases; $t(40) = 1.621$, $p = 0.113$. These results suggest that the effect of gender is not significant on thermal comfort in summer.

Table 9: Independent Samples Test of PMV in winter

		Levene's Test for Equality of Variances		t-test for Equality of Means						
		F	Sig.	t	df	Sig. (2-tailed)	Mean Difference	Std. Error Difference	95% Confidence Interval of the Difference	
									Lower	Upper
Temperature in winter	Equal variances assumed	.487	.487	.184	90	.855	.051	.280	-.504	.607
	Equal variances not assumed			.189	55.242	.851	.051	.271	-.493	.595

As shown in Table 9, an independent-samples t-test was used to check the statistical relevance of thermal comfort in males and females in the researched building in winter. Since Sig. (2-tailed) value is greater than 0.05, it can be concluded that there is no statistically significant difference in winter thermal comfort for male and female cases; $t(90) = 0.184$, $p = 0.855$. These results suggest that the effect of gender is not significant on thermal comfort in winter.

People coming from different regions might have different perception of the overall comfort level.

Table 10: Overall comfort distribution by nationality in summer

Comfort Overall in summer			
Home Country	Mean	n	Std. Deviation
China	4.27	15	1.831
Greece	2.90	10	1.969
India	2.70	40	1.522

From Table 10, it can be found that Chinese residents were relatively more satisfied with the overall comfort than people from India and Greece who feel overall comfort more dissatisfied. The standard deviation ranged from 1.5 to 1.9, which is the same as that in gender classification.

To make the problem more specific, thermal comfort is further analysed here. On a 7-point scale, 1 means cold and 7 means hot. Table 11 shows the mean thermal comfort level of the residents classified by nationality. It is shown that Indian residents are most sensitive to hot weather. Greek people and Chinese residents rank second and third.

Table 11: Thermal comfort in summer

Temperature in summer			
Home Country	Mean	N	Std. Deviation
India	6.00	41	.975
China	5.36	14	1.216
Greece	5.60	10	1.350

As mentioned in Section 2.1.3, the thermal neutral temperature is highest in India, followed by Greece and China. However, the results in this research show a completely different trend. This will be discussed in Section 6.1.

Table 12: Independent Sample Test of PMV between Indian and Chinese

		Levene's Test for Equality of Variances		t-test for Equality of Means						
		F	Sig.	t	df	Sig. (2-tailed)	Mean Difference	Std. Error Difference	95% Confidence Interval of the Difference	
									Lower	Upper
Temperature in summer	Equal variances assumed	3.326	.074	1.999	53	.051	.643	.322	-.002	1.288
	Equal variances not assumed			1.792	19.035	.089	.643	.359	-.108	1.394

As shown in Table 12 an independent-samples t-test was used to check the thermal comfort in Indian and Chinese residents the researched building in winter. Since Sig. (2-tailed) value is greater than 0.05, it can be concluded that there is no statistically significant difference in summer thermal comfort for residents from China and India; $t(53) = 1.999$, $p = 0.051$. These results suggest that the effect of nationality is not significant on thermal comfort in summer.

Table 13: Independent Sample Test of PMV between Chinese and Greek

		Levene's Test for Equality of Variances		t-test for Equality of Means						
		F	Sig.	t	df	Sig. (2-tailed)	Mean Difference	Std. Error Difference	95% Confidence Interval of the Difference	
									Lower	Upper
Temperature in summer	Equal variances assumed	.001	.973	-.461	22	.649	-.243	.527	-1.335	.850
	Equal variances not assumed			-.453	18.216	.656	-.243	.536	-1.369	.883

As shown in Table 13, an independent-samples t-test was used to check the thermal comfort in Chinese and Greek residents in the researched building in winter. Since Sig. (2-tailed) value is greater than 0.05, it can be concluded that there is no statistically significant difference in summer thermal comfort for residents from China and Greece; $t(22) = -0.461$, $p = 0.649$. These results suggest that the effect of nationality is not significant on thermal comfort in summer.

Inconvenience and Problems

What makes the residents feel uncomfortable? To find out the main reasons why the residents feel comfortable, the following question was included in the questionnaire survey:

<p>Generally, what would be the main reasons for discomfort in your room? (Multi-choice)</p> <p><input type="checkbox"/> Too cold</p> <p><input type="checkbox"/> Too hot</p> <p><input type="checkbox"/> Temperature too variable</p> <p><input type="checkbox"/> Temperature not enough variable</p> <p><input type="checkbox"/> Air too humid</p> <p><input type="checkbox"/> Air too dry</p> <p><input type="checkbox"/> Air too stuffy</p> <p><input type="checkbox"/> Air too smelly</p> <p><input type="checkbox"/> Not enough light</p> <p><input type="checkbox"/> Too much light</p> <p><input type="checkbox"/> Too much glare from sun and sky</p> <p><input type="checkbox"/> Too much glare from artificial light</p> <p><input type="checkbox"/> Too much noise from outside the building</p> <p><input type="checkbox"/> Too much noise from building systems (e.g. heating, ventilation, air conditioning, plumbing etc.)</p> <p><input type="checkbox"/> Noise (other than from building systems)</p> <p><input type="checkbox"/> Too much vibration</p> <p><input type="checkbox"/> Other _____</p>

Figure 49 shows the statistical results of this question. It can be found that “Too hot” was chosen by most of the residents (64 of 96), and it is closely related to our thermal comfort focus. Noise was also an important issue, according to 35 residents. 28 interviewees chose “too much glare” from the sky, while 26 residents chose “Not enough light”. “Air too stuffy”, “Air too dry”, “Too cold”, “Air too smelly” and “Too much vibration” were also chosen by more than 20 interviewees in the survey.

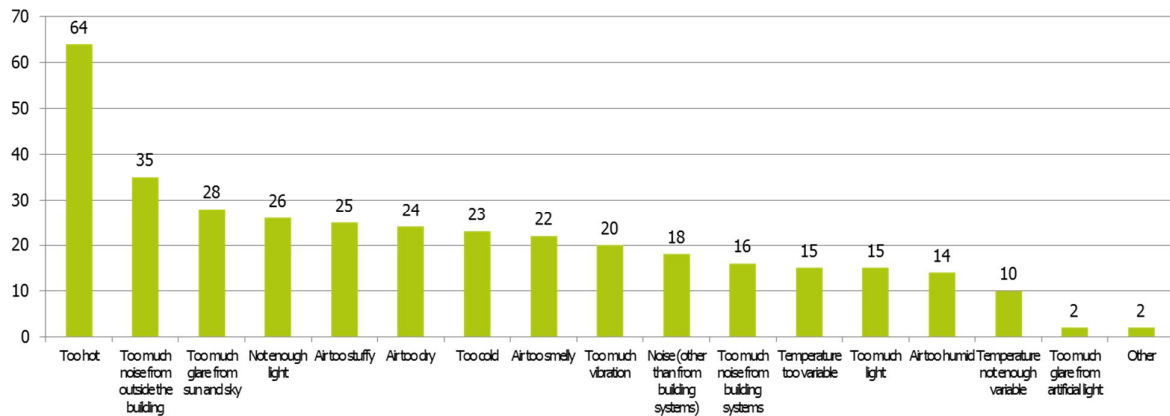

Figure 49: Main causes of discomfort

Since the window plays a vital role in the natural ventilation system in this researched building, the following questions below were included in the questionnaire:

- Are you able to open the window(s) whenever you want? Yes No
- If you are not able to open the window whenever you want to, how come? (Multi-choice)
 - You are not able to reach the window easily
 - It is not easy to position the window in an adequate position
 - Hindrance by draught
 - Hindrance by noise from outside
 - Anti-thief
 - Other reason(s): _____ (Please write it down)

Interestingly, some of the interviewees chose “Yes” in the first question, but they still chose the reasons that they could not open the window freely. This seems a bit contradictory, but it reflects the real situation of the residents. They think they can open the window freely, but there are still some difficulties preventing them to do that.

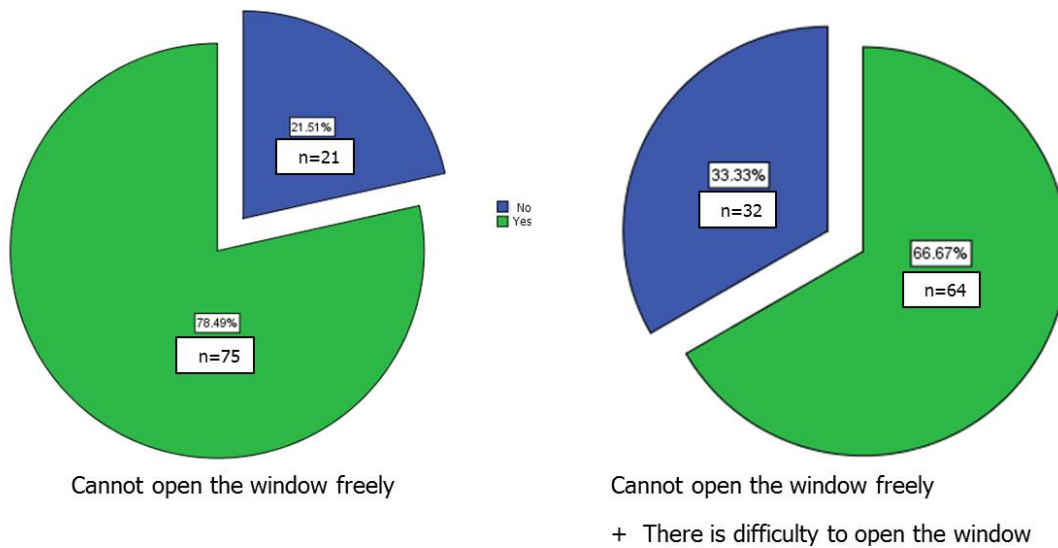

Figure 50: Whether the residents are able to open the window freely

The statistical result is shown in Figure 50. According to this pie chart, it can be found that 1/3 of the interviewees think they cannot open the window freely or there are difficulties to open the window.

What prevent the residents from using the window(s) as they like? To find out the answer to this question, the choices of the residents on the second question above were counted.

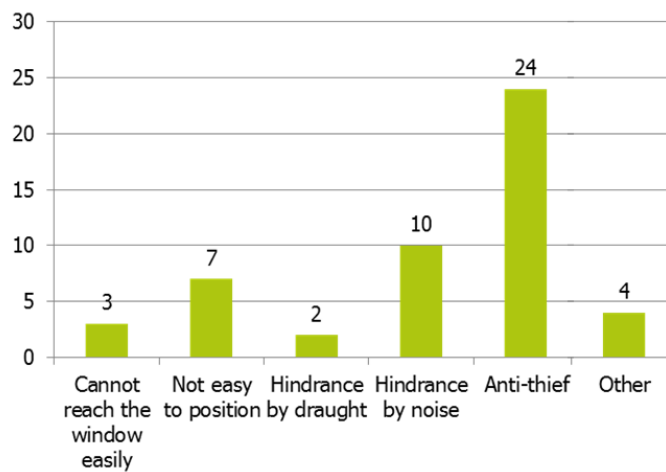

Figure 51: Reasons that prevent the residents to open the window freely

Figure 51 shows that 24 of the interviewees choose 'Anti-thief' on this question. Since 32 interviewees found it difficult to open the window freely, 24 here means 75% of

them think 'Anti-thief' is the main reason. Noise, Control difficulties were also chosen by around 1/3 of the interviewees who have difficulties with opening the window.

It should be noticed that "privacy problem" was mentioned by 4 interviewees in "other" and 5 interviewees in the discussion part, because it was not listed in the questionnaire. In total, 9 interviewees complained about it, which is almost the same as the number of the residents who complained about noise. Moreover, people reported the problem independently. If people write it down without any hint from the interviewer, this problem definitely affect their life a lot. Therefore we should pay more attention to this issue.

'Anti-thief' is a safety issue. To clarify it, the safety condition in the surrounding was addressed by the crime accounting data from Dutch police website. According to Figure 52, the crime rate in this area(the red dot is the building) in the past three monthes is much higher than in the campus (right part of the map). It seems that the safety in this area is not good, and it does influence the residents' feeling of unsafety.

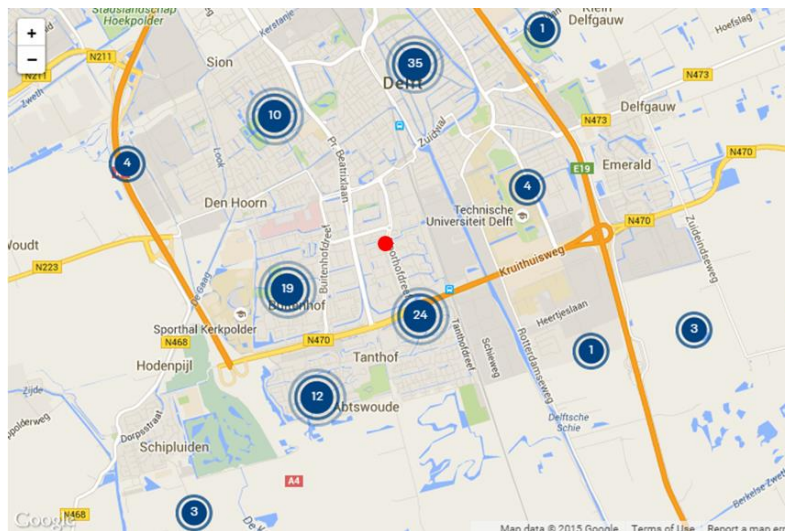

Figure 52: Crime accounting map

Source: [politie.nl]

When there is no proper privacy-protecting method, the residents will shut their curtain as the last solution to avoid unfavourable glaring. as shown in Figure 53, it would be very annoying for the residents, if there is not such a film there.



Figure 53: The effect of privacy film

To verify the relevance between privacy film and curtain status, the researcher did a further field study about the relationship between whether there is a visual privacy film present and whether the residents shut the curtain. The investigation was carried out from 16:00-17:00 on 2nd Sep, which was a Wednesday.

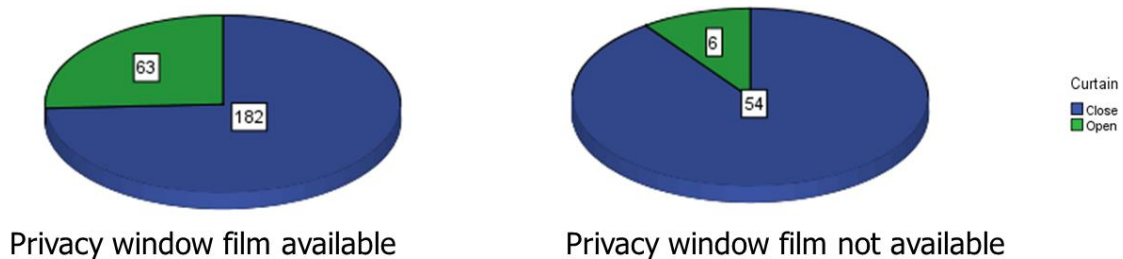

Figure 54: The influence of the visual privacy film

Figure 54 shows the result of the investigation. Left pie chart shows the group with privacy film, while the right pie chart shows the group without privacy film. In the rooms with visual privacy film, around 25% of the residents opened their curtain. In the rooms without visual privacy film, only 11% of the residents did that. The difference is obvious and it indicates the importance of appropriate privacy-protecting opportunities.

Conclusion

According to the results above, a general idea about the comfort level in the building can be drawn, and the reasons of discomfort are analysed.

The general comfort and thermal comfort level were analysed by gender and nationality. Although the mean value differs by gender and nationality, there is no significantly statistical relationship found in the t-test.

“Too hot” was found to be the main reason of discomfort for most residents in the building, which verifies the necessity to improve the thermal comfort level in this building.

Meanwhile, 1/3 residents complained that they couldn't open the window freely or there is difficulty to do that. The main reason is about safety and privacy, and the privacy window film plays an important role in this issue.

Therefore, further research about thermal comfort in this building, and the possibilities to naturally ventilate the rooms are further analysed in section 5.2 and 5.3. In chapter 6, specific solutions are discussed to solve the problems.

5.2 Building Scale Analysis

Building scale analysis focuses on the difference of thermal comfort from a entity perspective. The differences between different parts of the researched building will be analysed in this section.

5.2.1 General Temperature Comparison

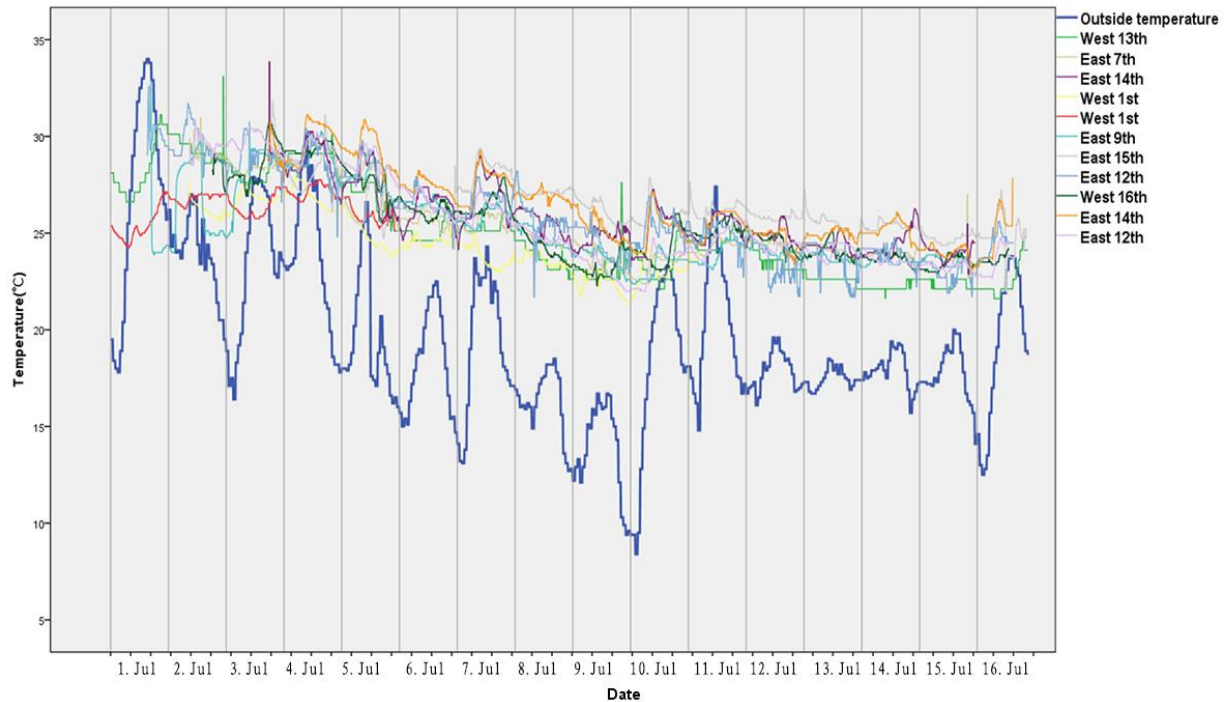

Figure 55: The temperature curve in the experimental period

Figure 55 shows the temperature variation curve from 1st July to 16th July in 2015. The thick blue line represents the outdoor air temperature gained from meteorology station 5km away, while the other lines represent the operative temperature in different rooms in the building. It can be found that the outdoor temperature is lower than the indoor temperatures most time during the experimental period, except for several temperature peaks. Although the outdoor temperature reached 34°C on 1st.July, it was just a few hours in the afternoon. The outdoor temperature can change more than 15°C in one day, while the difference of the indoor operative temperature in one room usually doesn't exceed 3 °C, which is quite stable. On the other hand, during a longer period of more than 10 days, the indoor temperature tends to be closer to the outdoor temperature.

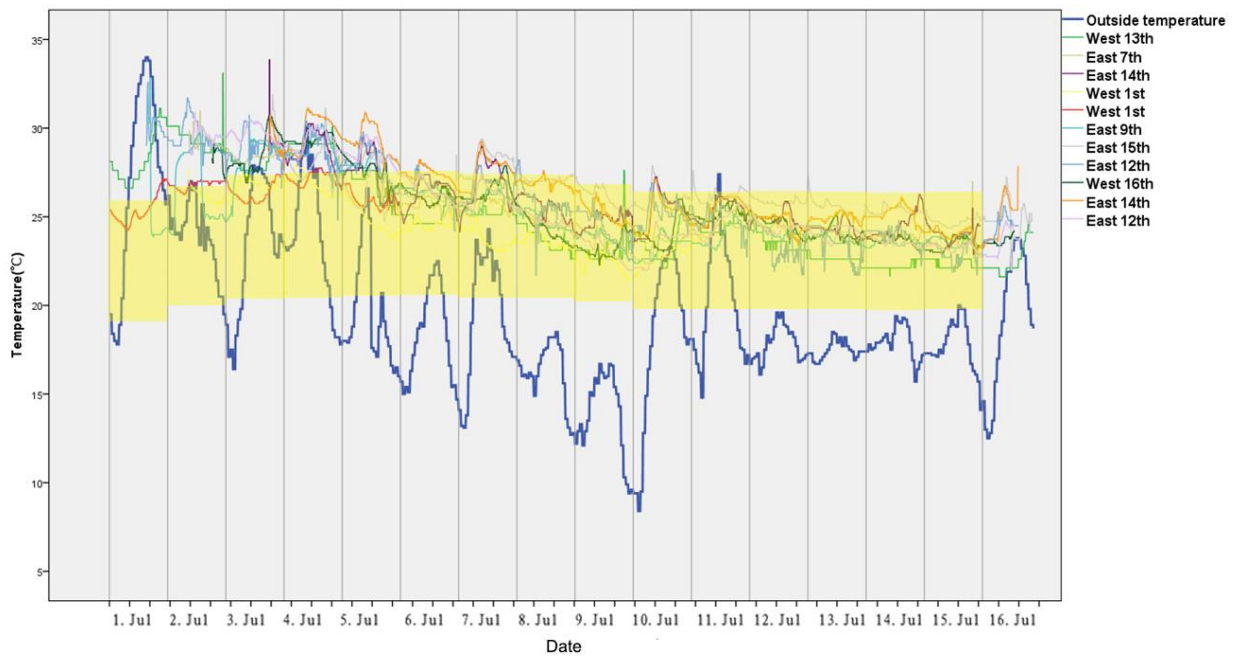

Figure 56: Comfort zone with real temperature comparison

As explained in Section 2.1.2, the comfort zone is drawn from the outdoor air temperature in the pasting days. When comparing the real temperature and the comfort zone, the thermal comfort level can be illustrated more clearly. As shown in Figure 56, the indoor temperature in most rooms was within the comfort zone from 6th July to 16th July. The outdoor temperature on 1st.July exceeded comfort zone a lot in day time, which resulted in high indoor temperature in the following 4 days.

5.2.2 Temperature Comparison of Same Floor&Side

Before analysing the temperature difference in various floors and locations, it is necessary to know whether the temperatures in the same floor and same façade are always the same. Therefore, the temperatures on 12th floor in the east side and 14th floor in the east side are compared separately.

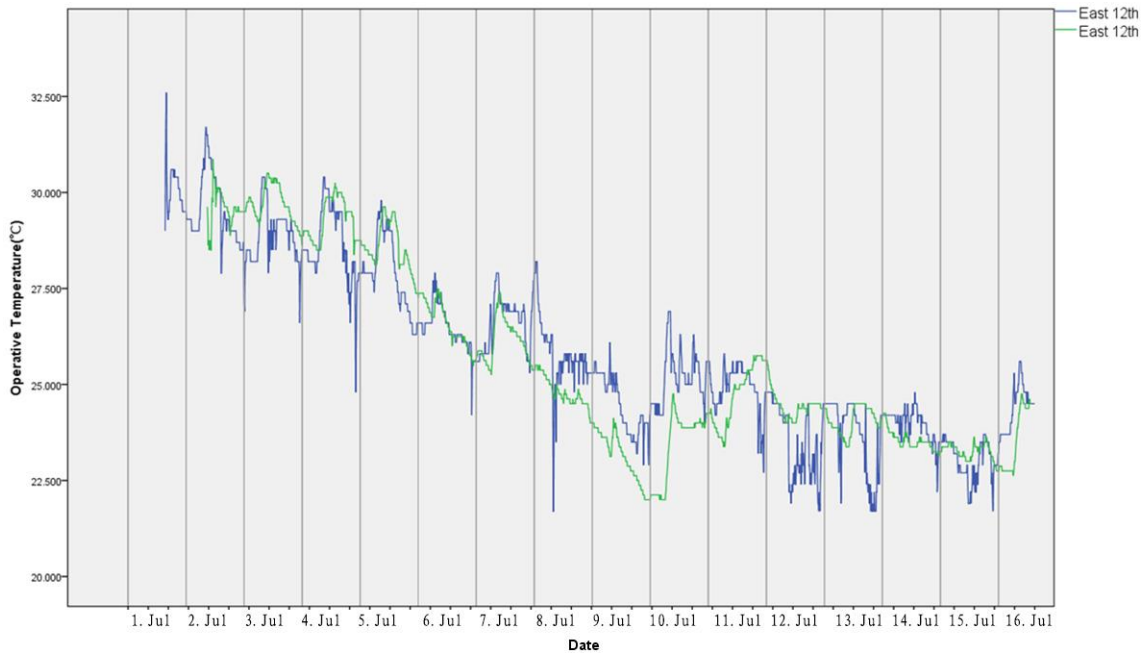

Figure 57: The operative temperature in two rooms on 12th floor on the east side

Figure 57 shows the temperatures in two rooms on 12th floor on east side of the researched building. Apparently, the temperatures in these two rooms were very close to each other. In the 14-day period, the difference was usually less than 1 °C. There was not one room that is always warmer or cooler.

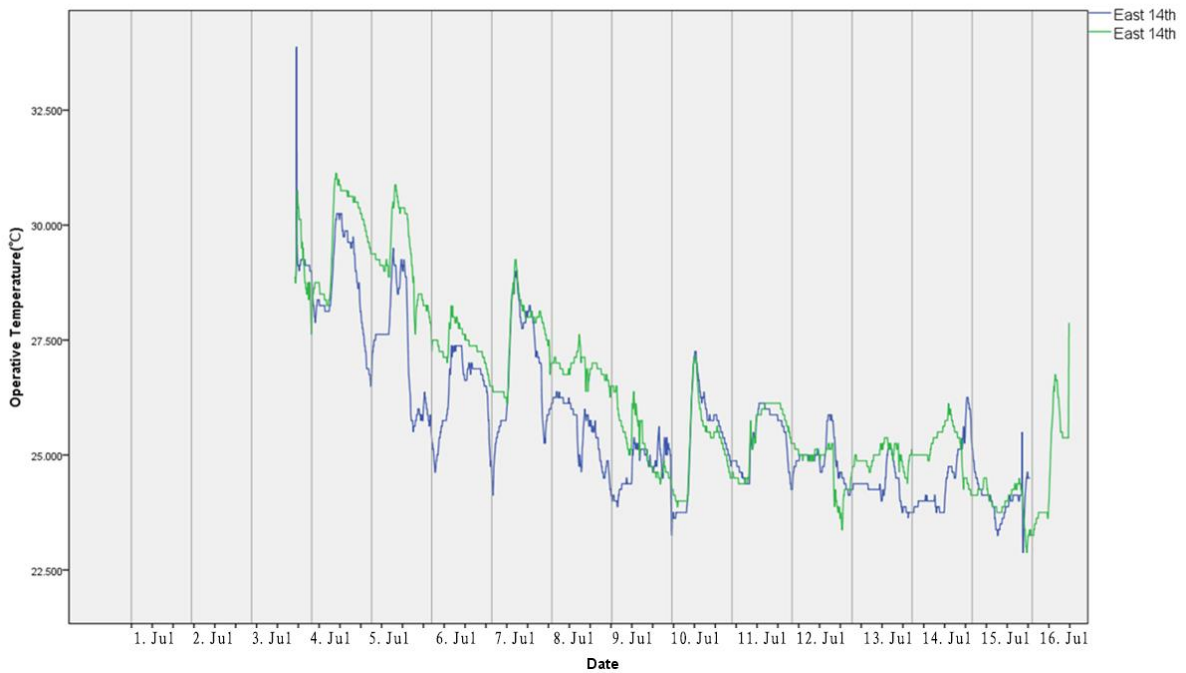

Figure 58: The operative temperature in two rooms on 14th floor on the east side

To double check the results, the same comparison is made on 14th floor, which is shown in Figure 58. At the beginning, the two lines are almost together. Then the green line representing operative temperature becomes higher than that of the blue one for around half of the whole period by approximately 0.7°C. After that, they get close to each other again.

5.2.3 Temperature Comparison of Different Floor

Height is an important characteristic aspect of a high rise building, which has already been found to be influential on thermal comfort in a high rise building[28]. Therefore, the temperature difference between different floors would be one of the most important parameter in this study.

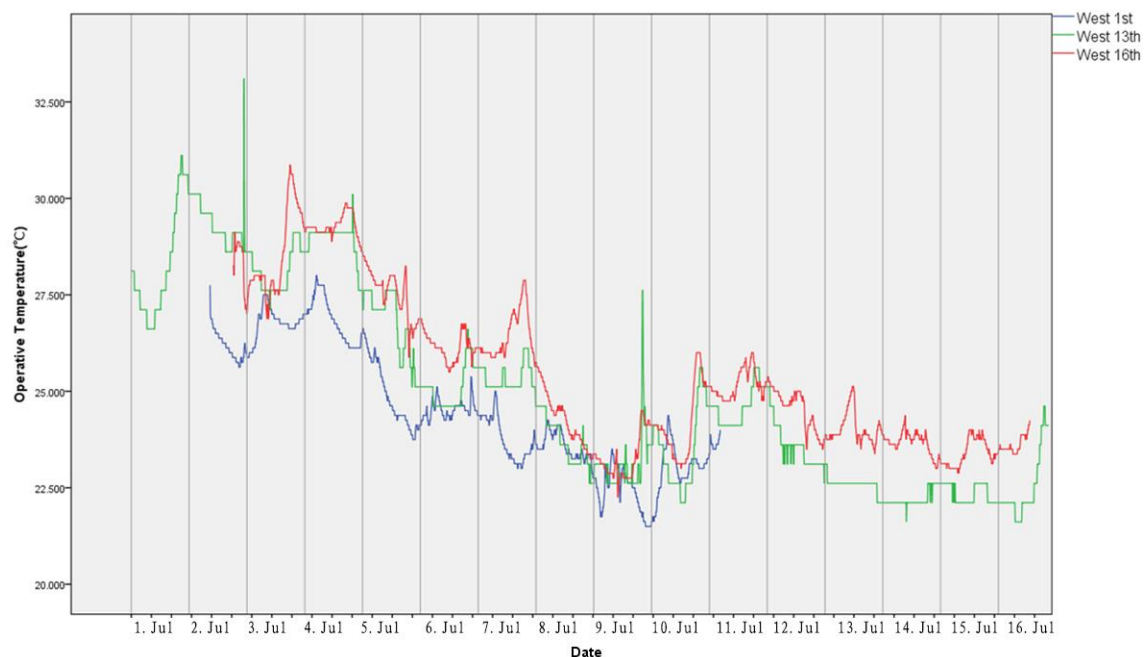

Figure 59: The operative temperature comparison on the different floors on the west side

In Figure 59, there are 3 lines representing the operative temperatures on different floors on the west side. The red line represents the operative temperature on 16th floor, and it is always higher than the other two floors. The temperature on the 13th floor is represented by the green line, and it lies in the middle of the other two lines in most times. Meanwhile, the temperature on the 1st floor is always the lowest. The

difference between two lines next to each other lies in a range of 0-2°C, and it fluctuates a lot. Interestingly, the operative temperatures of different rooms tend to be close to each other when the temperature is low.

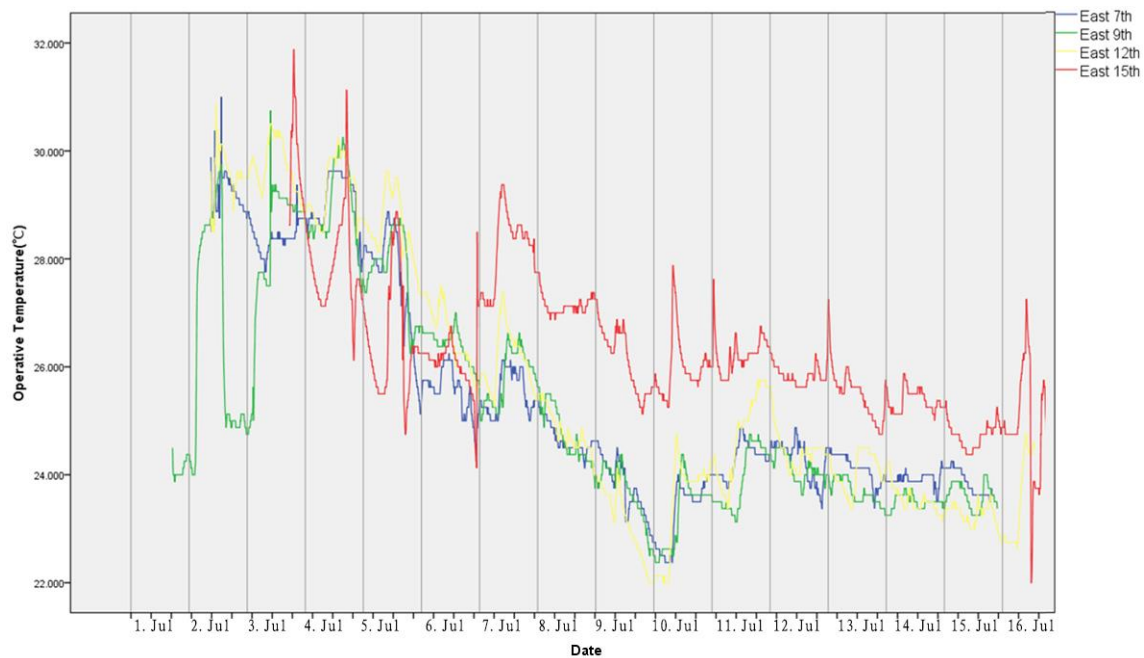

Figure 60: The operative temperature comparison on the different floors on east side

On the east side, a similar trend can be found. In Figure 60, there are 4 lines representing the temperature of the different floors on the west side. When the temperature is very high, the temperature lines intertwine with each other closely. When the temperature drops, the temperature on 15th floor still keeps high. At the same time, the temperature on 7th, 9th and 12th floor are still very close in this period.

The green line and the red lines fluctuate a lot at the beginning, which is much more than the common variation in a room. The owners of these two rooms didn't want the researcher to enter their room, so they just gained the sensors from the researcher and installed them by themselves. As a consequence, they might have delayed the installing of the sensor, so the data recorded was not exactly the indoor temperature in their rooms, but somewhere else.

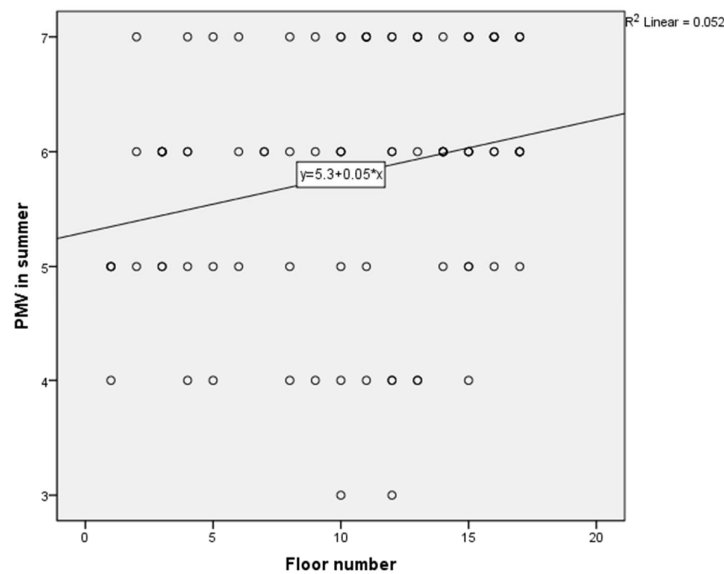

Figure 61 : Residents' response to the temperature on the different floors

To verify the results from the subjective perspective, the residents' thermal perception was counted. Figure 61 shows interviewees' average thermal sensation in summer. On vertical axis, 7 represents hot and 1 represents cold. People living at the top floors feel hotter, while the residents on the 1st floor feel more neutral. In the middle floors, the sensation can fluctuate and there is no specific rule. The fitted line clearly indicates the trend. Table 14 shows the mean value and other related information in list.

Table 14: Mean PMV of the residents for summer case

Floor number	Mean	N	Std. Deviation
1	4.75	4	.500
2	6.00	3	1.000
3	5.71	7	.488
4	5.60	5	1.140
5	5.33	3	1.528
6	6.00	3	1.000
7	6.00	2	.000
8	5.50	4	1.291
9	5.67	3	1.528
10	5.50	8	1.414
11	6.17	6	1.329
12	5.29	7	1.604
13	5.83	6	1.472
14	6.00	7	.577
15	5.89	9	1.054
16	6.50	8	.756
17	6.22	9	.667
Total	5.81	94	1.080

5.2.4 Temperature Comparison of Opposite Side

Since the building is mainly east-west oriented, there should be some difference in temperature due to different solar radiation on different sides. The researcher didn't manage to set the sensors exactly on the same floor at both sides, so the temperatures on close as possible floors are chosen.

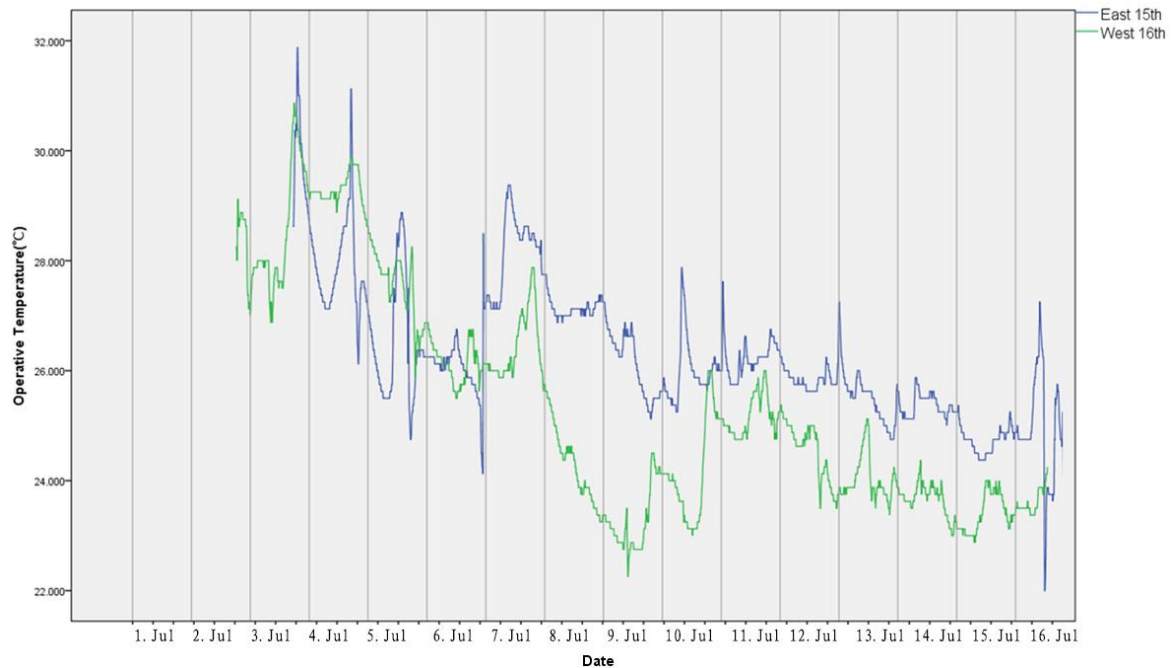

Figure 62: The operative temperature comparison of the close floors on different sides

From Figure 62, it can be found that the temperature on the west side is lower than that on the east side during most of the time. The maximum temperature difference lies around 2°C. While the temperature is higher, they are closer to each other. At the beginning, the temperature on the east side fluctuates a lot. As mentioned in Section 5.2.3, the sensor on 15th floor was installed by the occupant herself, so she has delayed to install it, which leads to inaccuracy.

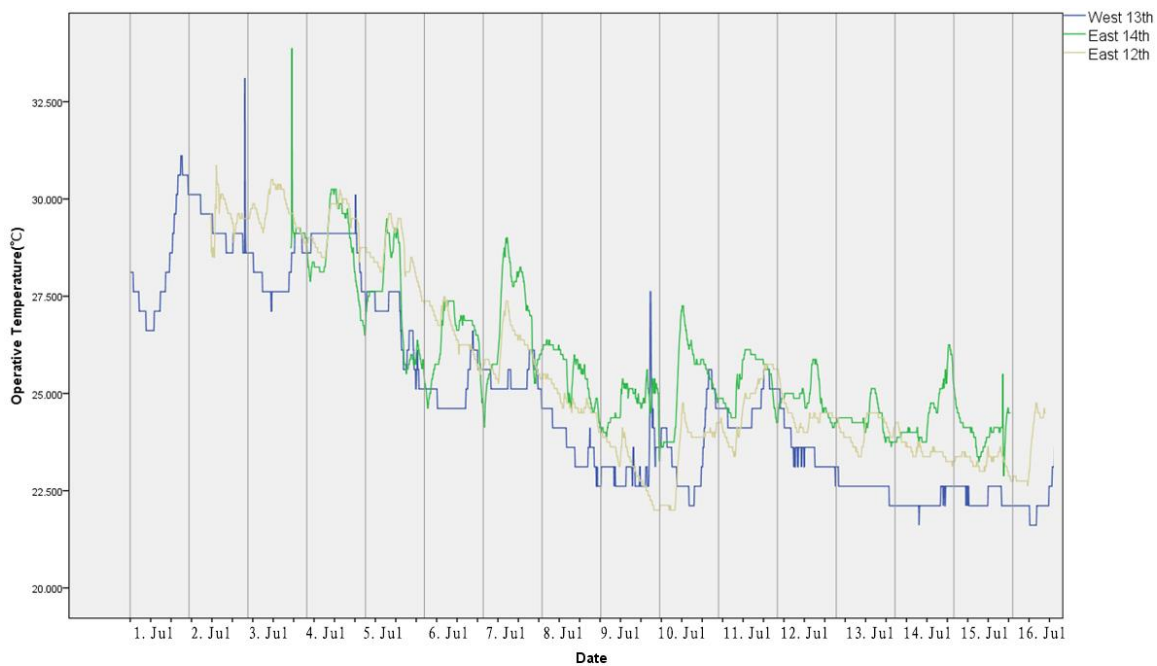

Figure 63: The operative temperature comparison of the close floors on different sides

Similar rules rule can be found in Figure 63. In this graph, only a red line represents the temperature in one room on the west side. It can be found that the temperature on the west side is usually lower than the temperatures in any other rooms on the east sides. The difference tends to be smaller when the temperature is higher. In general, the difference is less than 1°C.

5.2.5 Wind velocity Comparison

At building-scale, the air velocity was measured on the outside corridors, and the values are compared with the values received from the Rotterdam Meteorology station, which is 5 kilometres away from the building.

Table 15: Wind velocity distribution

Floor	Wind velocity-East(m/s)	Std.Deviation	Wind velocity-West(m/s)	Std.Deviation	Wind velocity-Meteorology station(m/s)
17	0.23	0.12	1.28	0.75	-
9	0.48	0.39	2.31	1.15	-
1	0.69	0.38	1.92	0.88	-
0	-	-	-	-	5

From Table 15, it can be found that the air velocity doesn't really increase with the height. On the west side, the air velocity on the top floor is 1.28 m/s, which is even lower than that on the 1st floor. On the east side, the air velocity on the top floor is 0.23 m/s, which is also lower than that on the 1st floor. The air velocities on east side were always lower than those on west side in the experiment. All of the air velocities measured in the building were much lower than that at the meteorology station (5 m/s). The standard deviations of the measured wind velocity differ from 0.12 to 1.15, which is quite large compared with the wind velocity.

5.2.6 Humidity Comparison

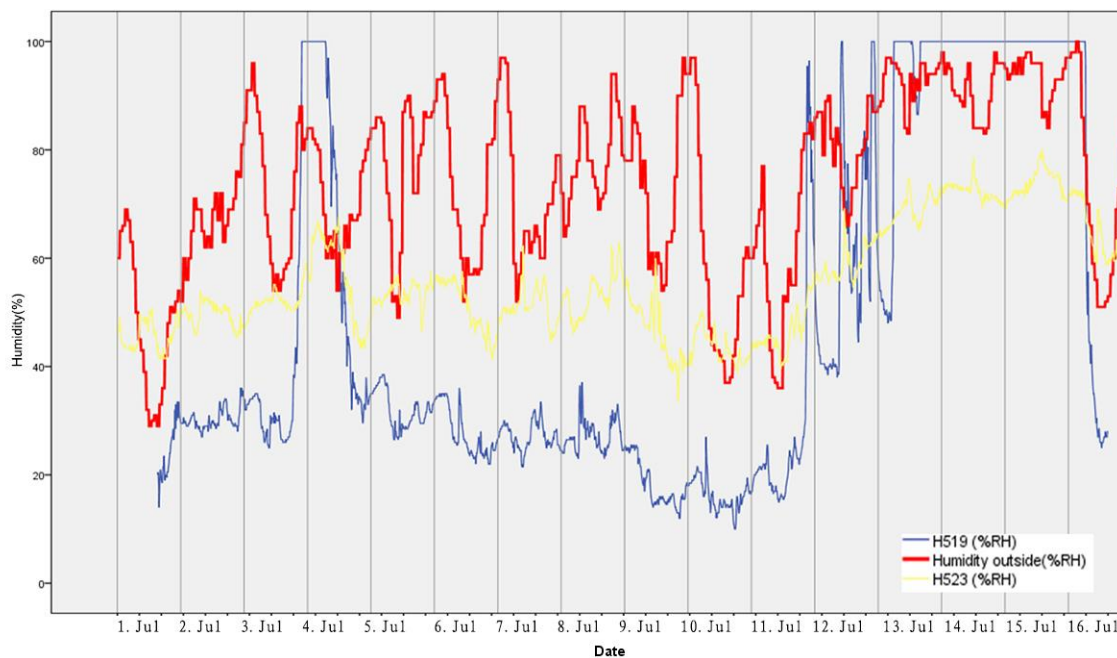

Figure 64: The humidity comparison in different rooms

The humidity monitors were set up in two rooms (519 and 523), and the results are shown in Figure 64. The blue line and the yellow lines represent the humidity in room 519 and 523 respectively, and the thick red line represents the outdoor humidity. From the graph, it can be found that the outdoor humidity is usually higher than the humidity in any room.

The humidity data in room 519 reached 100% for several times during the experimental period. According to the discussion with the resident in that room, nothing special happened in those days. Normally, it is not realistic for the humidity to stay at 100% for so long time. Hence it is more reasonable to assume that something happened with the sensor. For example, condensation occurred or the equipment was just malfunctioning.

5.2.7 Summary and Conclusion

In this section, thermal comfort level is carefully analysed at a building scale. In general, the indoor temperature in most rooms lied in the comfort zone most of the time in the experimental period, except 4 days after the extremely hot day on 1st July.

From spatial distribution perspective, temperature on the top floors was found to be 1-2°C higher than 1st floor, and the temperature on the floors in the middle falls in between. PMV vote verified that residents also felt the same trend. The temperature on the east side was found to be 1-2°C higher than that on the west side.

Wind velocity was also found to be different on different orientations, but there was no significant difference found between different heights. Air velocity measured on the west outside corridor was found to be higher than that on the east corridor. On different height, the difference was not significant.

It is found that the indoor humidity is relatively lower and more stable than the outdoor humidity. The sample size of humidity measurement is relatively small, and there might be error in the measurement.

Further analysis about thermal comfort at room scale is given in the next section.

5.3 Room Scale Analysis

The thermal comfort level is analysed in this section at room scale. As a result, it focuses more on the thermal comfort of the residents. Temperature and air velocity are separately analysed in this section. Both measurement and simulation are simultaneously applied in this section to verify each other and gain more precise results.

5.3.1 Temperature Distribution

A. Measurement Results Analysis

First of all, the general temperature in a room should be analyzed. Figure 65 shows the operative temperature data in one room for the whole experimental period. The thick black line represents the outdoor temperature while the other seven lines represent the indoor operative temperature of different locations in the room.

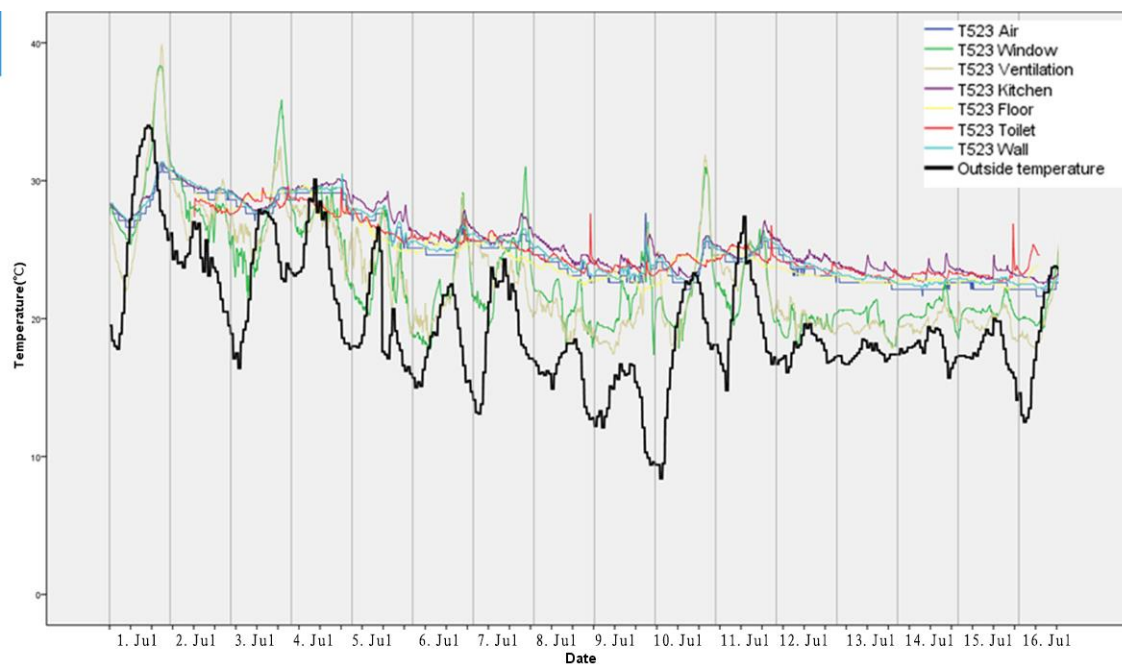

Figure 65: Temperature comparison in one room

The indoor temperature was more stable and higher than the outdoor temperature during most time in the experimental period. From the graph, it can easily be found that two green lines are closer to the thick black line, compared with other lines. These two lines represent the temperature measured at the window and ventilation

grill, which have direct contact with the outdoor air. The difference among the temperatures at other measurement points is less than 1°C , and there is not a point that is always hotter.



Figure 66: Comparison of the operative temperature and wall temperature

From Figure 66, it can be found that there is subtle difference between the wall and air temperature. The air temperature is always slightly lower than the wall temperature. Although the difference is even less than 0.5°C , the trend is very clear.

It should be noticed that the sensor is made of metal, which is thermally conductive. Since the sensor was directly fixed on the wall without any thermal insulation, the measured air temperature could be affected by the wall temperature. Therefore, the real difference might be more than that we measured in this set-up.

The resolution of the blue line seems to be different to that of the green line. After double check, it was found that the resolution of the sensor represented by the blue line might be wrongly set as 0.5°C , which can cause inaccuracy.

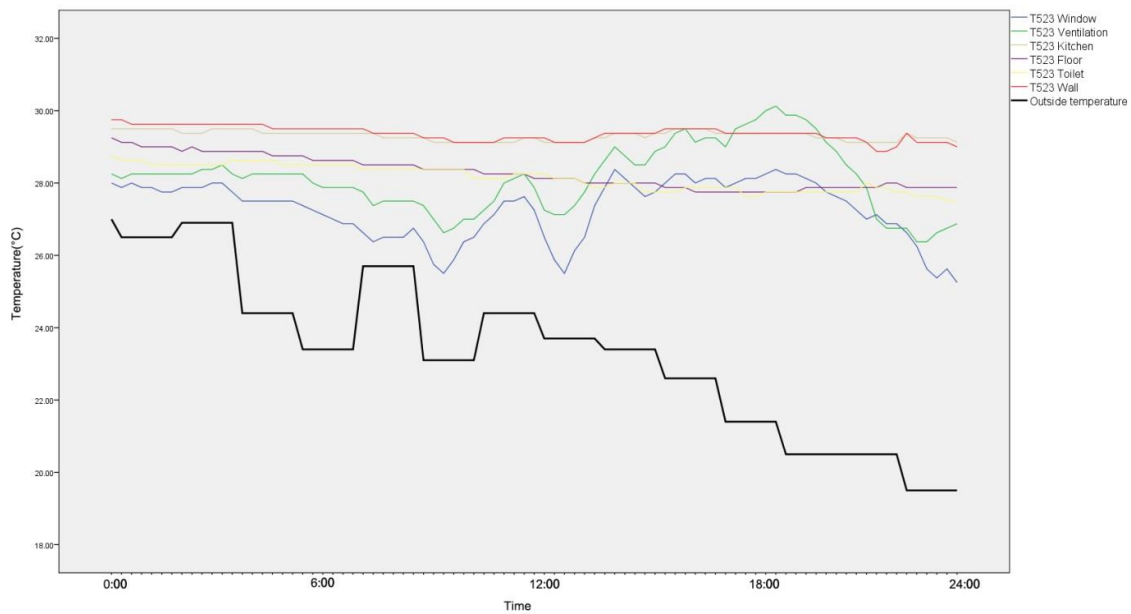

Figure 67: Temperature variation on 2nd July

To better understand the temperature variation in one-day scale, the temperature variation on 2nd of July—the first day after the extremely hot day is showed in Figure 67. The temperature in the room was around 29°C for a whole day, which is definitely too hot. The temperature of the window and ventilation grill fluctuated more, but it was still out of the comfort zone. The thick black line represents the outdoor temperature, and it drops rapidly after 12:00. However, the indoor temperature changed very little.

B. Simulation Results Analysis

To understand the detailed temperature distribution at human scale in the room, CFD simulations of one typical room was made. As mentioned in Section 4.1, three different cases were simulated. The results are shown in two cross-sections and one horizontal section. The chosen sections are listed in Table 16.

Table 16: Sections showed in the CFD simulation

	<p>Horizontal section: This section is set up at 1.5m height, which can show the temperature and the air velocity at the residents' sitting height.</p>
	<p>Section A: This cross section cuts the room at the exhaust in the kitchen. Moreover, it is close to the window. Therefore the air pattern from the inlet to the outlet can be clearly shown in this section.</p>
	<p>Section C: This section is cut at the extractor in the toilet and the corner part of the living room. It can help us to understand the air pattern in the inner part of the room.</p>

Case1: Extractor+ Ventilation Grille

Residents who really care about their privacy always shut the curtain. In this situation, only the ventilation grille can provide air. Hence, Case 1 is very common in the building.

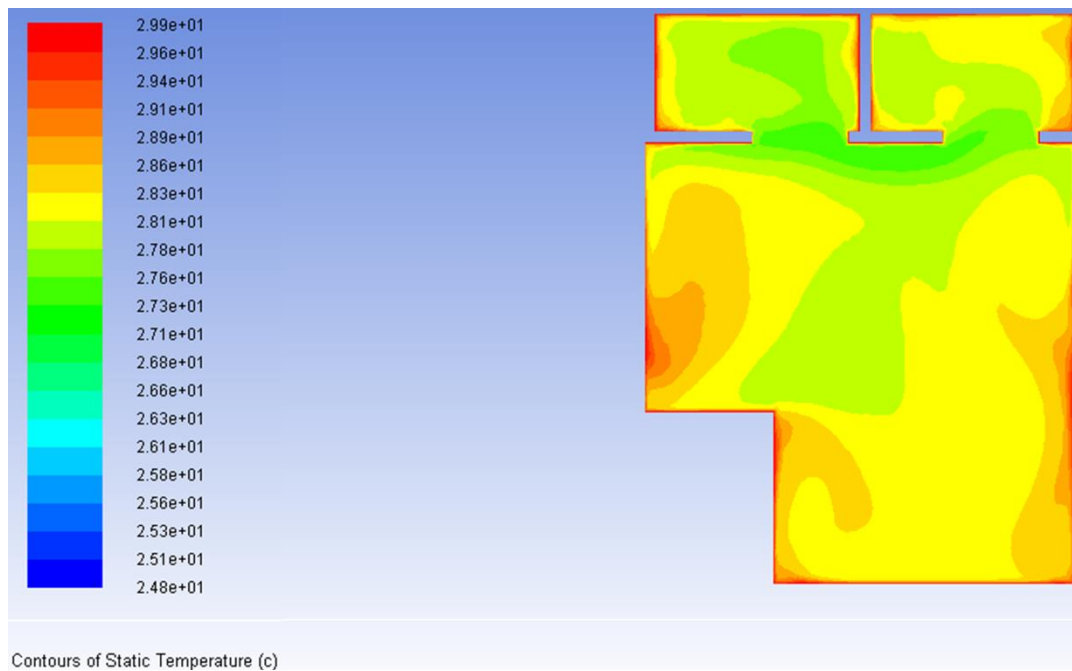

Figure 68: the temperature contours for case1- Horizontal

From Figure 68, the temperature contours indicate clearly that the temperature in most parts of the room can only be only 1 or 2°C lower than the wall temperature. Interestingly, the most cool part is in the kitchen and toilet, which is far away from the inlet. Apparently, the cooling effect is not so good in this situation. Since the ventilation grill is the only air inlet, there is not enough cool air to cool down the room. In the left part of the section, there is a blind corner for ventilation, which lead to higher temperatures there.

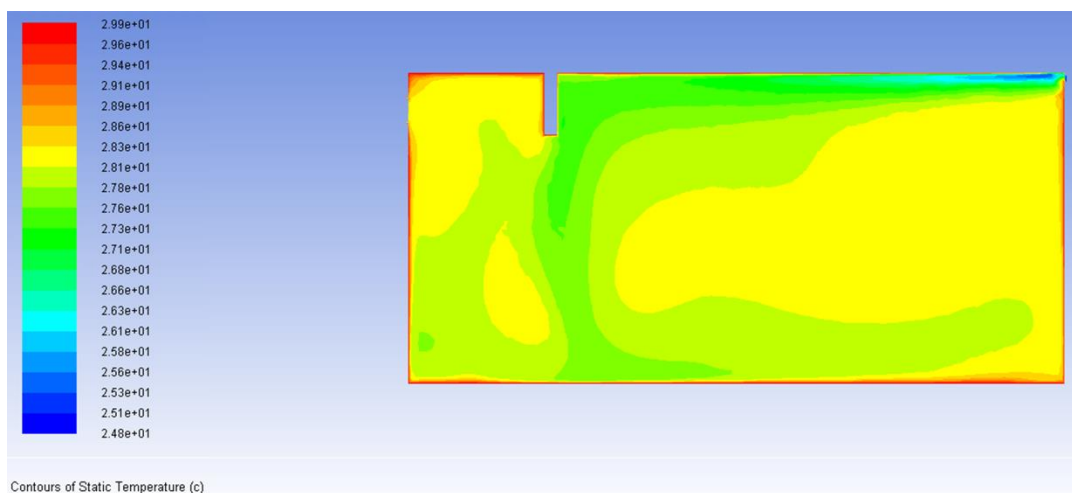

Figure 69: the temperature contours for case1- SectionA

Figure 69 shows the temperature distribution in Section A. From the temperature contours above, it can be found that the cold air is mainly close to the ceiling, and some parts in the kitchen and the ground. This can explain why toilet and kitchen are cooler than the living room, as shown in Figure 68. The air directly flows via the room and goes to the exhausts in the toilet and the kitchen. Due to gravity, the cool air falls down, but it only cools down the ground and the toilet, which doesn't help to improve the comfort level at human height.

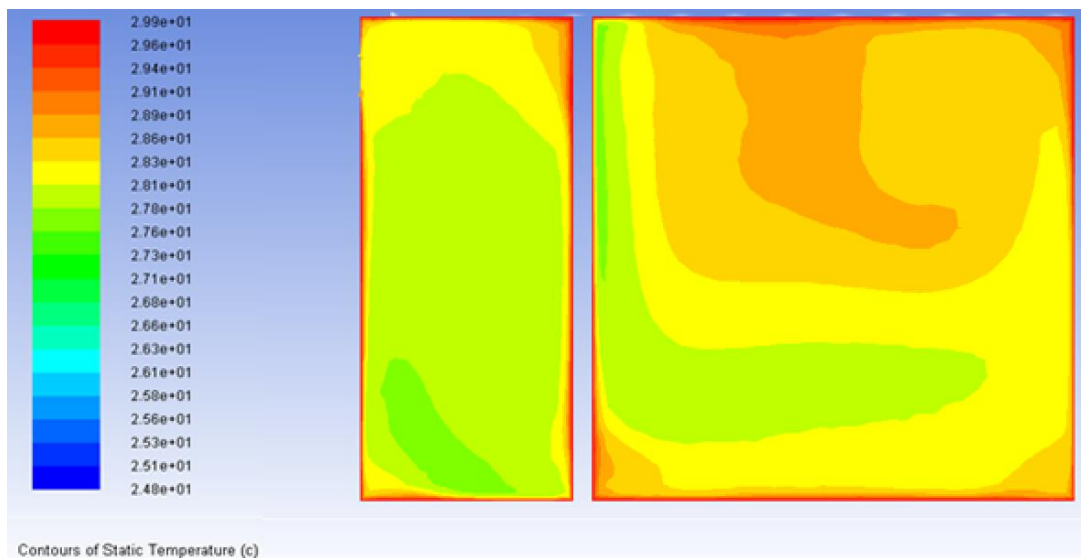

Figure 70: the temperature contours for case1- Section C

Figure 70 shows the thermal pattern in Section C. In this section, the situation is very similar. The toilet is relatively cooler than the living room part, while it is hot in the upper part of the living room.

Case2: Extractor+ Ventilation Grill+ Window (Open from the bottom)

For most residents, Case 2 is acceptable when they are at home. They only need to open part of the curtain and then they can enjoy more fresh air. The indoor operative temperature is also found to be similar to the on-site measurements.

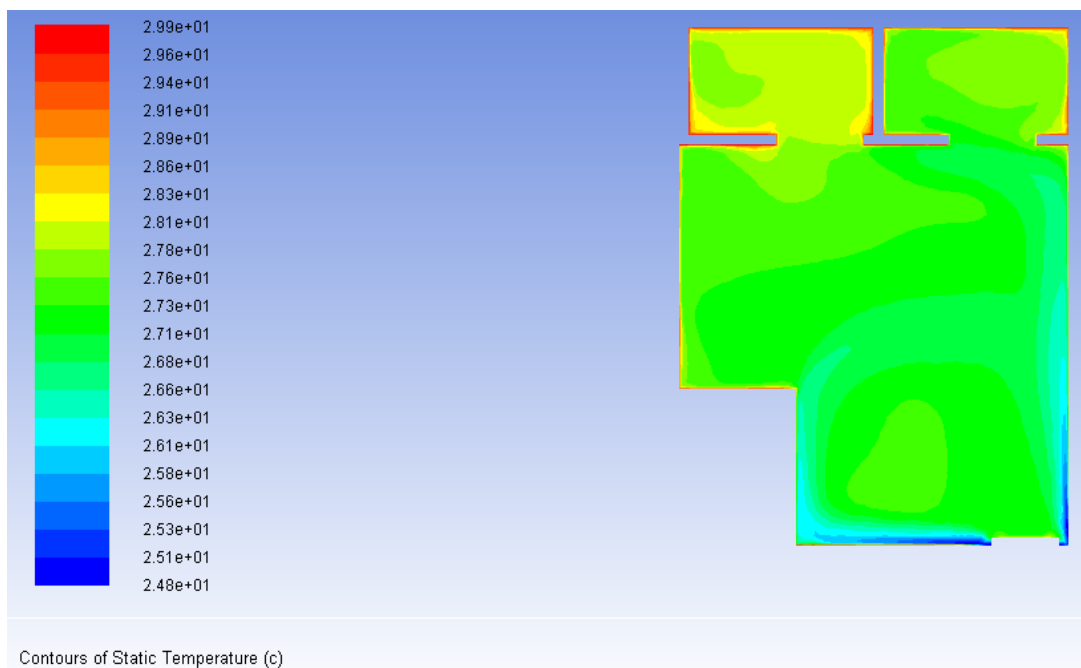

Figure 71: the temperature contours for case2- Horizontal

In Figure 71, it is obvious that the temperature distribution in case 2 is better than in case 1. In the horizontal section above, we can find that the temperature in most parts of the room are green, which represent 27°C . That is 2°C lower than that in the same area in case 1, and the distribution of air temperature is also much better. There is no apparent blind corner for ventilation.

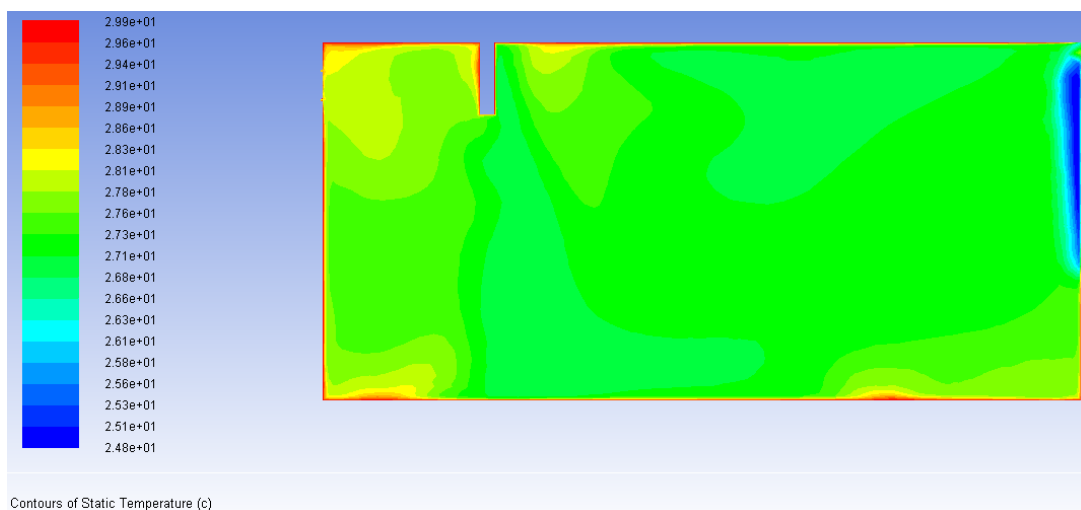

Figure 72: the temperature contours for case2- Section A

Figure 72 can also validate our conclusion. The temperature close to the window is the lowest, since it is the main air inlet, and the thermal insulation of the window is not so good as the wall. This is also verified by the measurement. The temperature in the rest area are around 27 °C. We can still find the same colder area close to the ceiling and the toilet, but the difference is very subtle and negelectable.

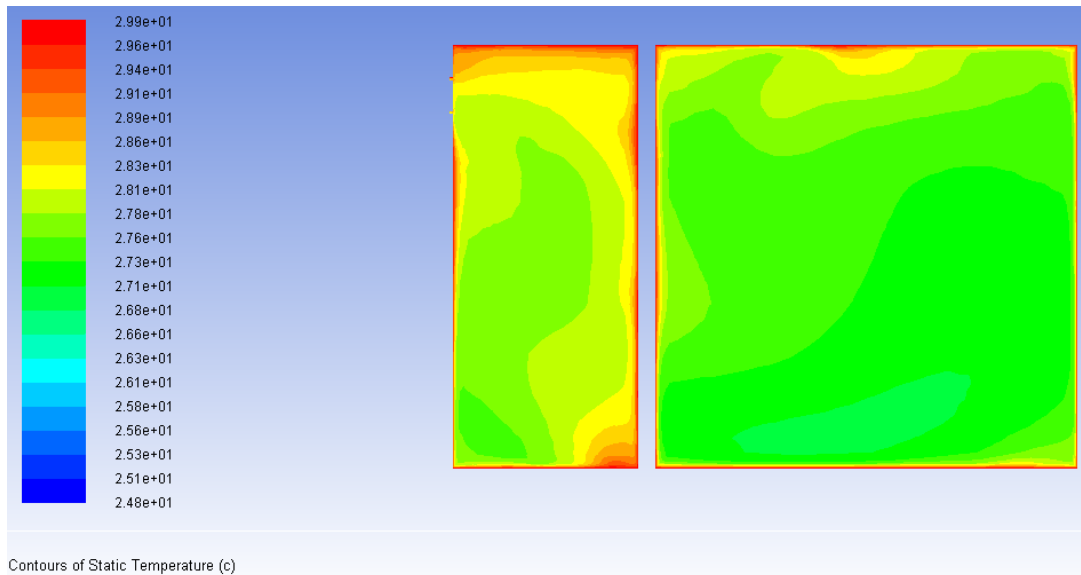

Figure 73: the temperature contours for case2- Section C

The same conclusion can be drawn from Figure 73. The temperature is well distributed and the temperature is not so high any more. There are blind corners in the toilet, but that will not affect the thermal comfort a lot, since the residents only stay there for a very short time.

Case3: Extractor+ Ventilation Grill+ Window (Open from the side)

Case 3 is relatively ideal for thermal comfort, but that is not acceptable for everyone. To realize this case, the residents have to open most part of the curtain. Since the window is completely open, it is easy for strangers to burst into the room through the window, which gives the feeling of unsafety. Therefore, noone does that when they are out or sleeping. Even when they are at home, many residents still don't like this way because of the unsafety feeling, especially for the female residents.

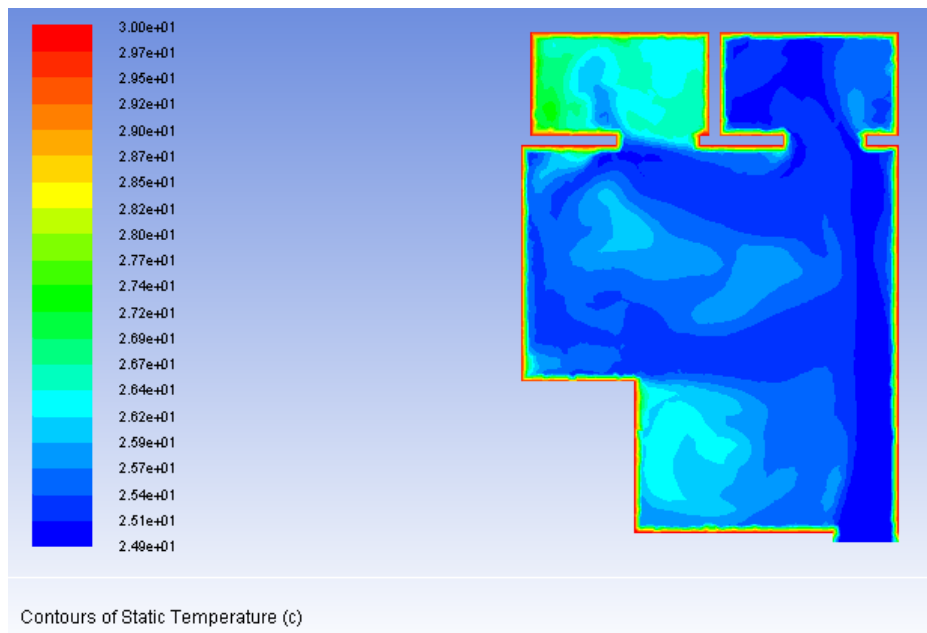

Figure 74: the temperature contours for case3- Horizontal

Figure 74 shows the horizontal temperature distribution in Case 3. As shown in the graph, most parts of the room are blue, which represents 25°C to 26°C, which is almost the same as the temperature of the natural wind. Natural wind really cools down most parts in the room in this case, and the potential is largely utilized. There is an obvious cold flow from the window, and it forms a “cold band”, where the air is coolest. As a result, the areas directly affected by the wind are around 1°C colder than the other areas.

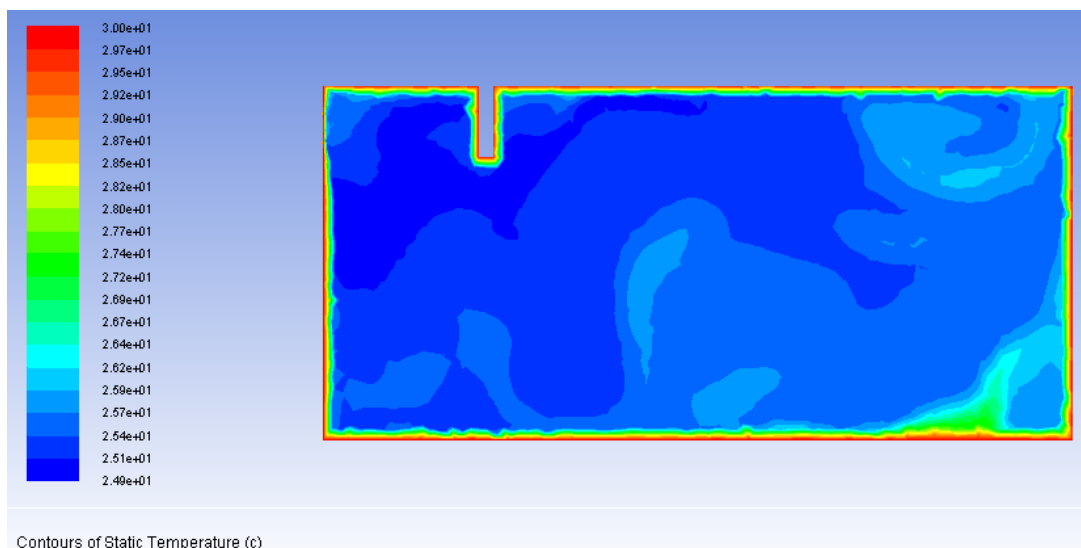

Figure 75: the temperature contours for case3- Section A

In Figure 75, it can be found that the indoor temperature is almost the same as the inlet air temperature--around 25 °C, which is quite good for a summer situation. The temperature at different height doesn't differ more than 1°C, which is also ideal. There is only a small blind corner under the window, but residents seldom stay there.

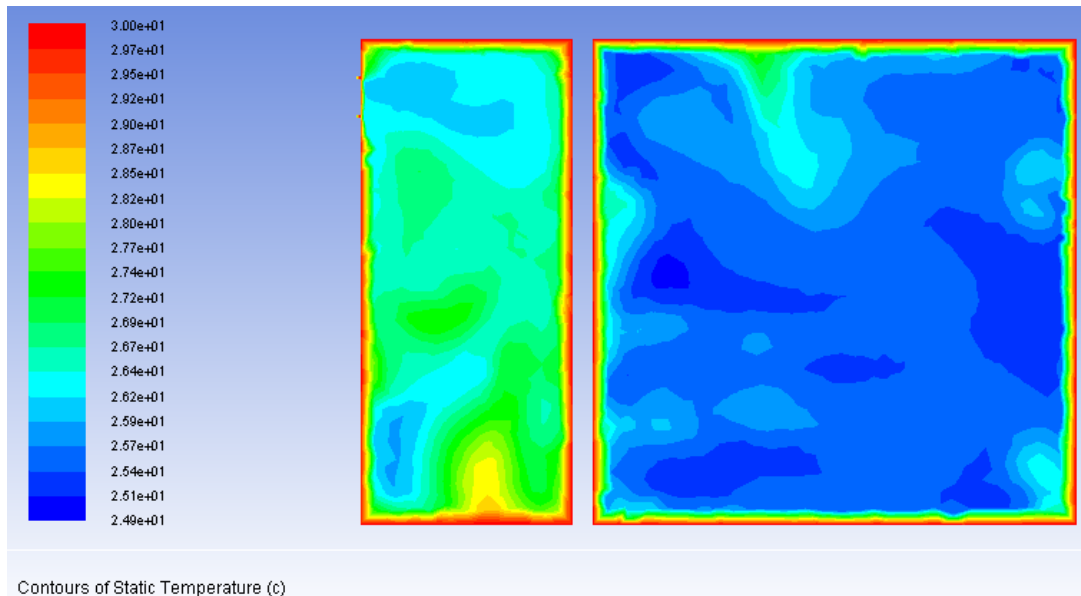

Figure 76: the temperature contours for case3- Section C

In Figure 76, it can be found that the temperature is a bit higher than in section A, since it is farther away from the window. The temperature in right part (living room) is around 25.5°C, which is very close to the inlet air temperature. The temperature in left part (toilet) is around 27°C.

5.3.2 Air velocity distribution

Apart from temperature, air velocity is also a predominant parameter in thermal comfort assessment. In this section, the air velocity distribution will be further analysed to assess room-scale thermal comfort.

A. Measurement Results Analysis

The air velocity was measured in three rooms. In room 523, the window was open from the bottom, and the window was closed in the other two rooms. The air velocity

sensor was set up in the centre of the rooms at 1.5m height, as mentioned in section 3.6.2. It measured the actual air velocity over 1 hour and then the average air velocity in this period was gained.

Table 17: Indoor air velocity in different rooms

Room number	Average Air velocities(m/s)	Maximum Air velocities(m/s)
523	0.0131	0.25
11	0.0045	0.28
517	0.0012	0.19

According to the measurement results shown in Table 17, the average air velocity in all the three rooms is usually very low, and the average air velocity in rooms 523 is obviously higher than that in rooms 11 and 517. It should be noticed that a low average air velocity doesn't mean that the air is always so still, since the value is out of the measuring range of the equipment. In fact, it indicates that there is no wind in most periods, while at other times there can be wind. The maximum air velocity in the rooms, where the window was open, reached 0.19m/s and 0.28m/s, which is close to that in the room with the window open.

As mentioned in Section 2.1.2, an indoor air velocity under 0.2 m/s is regarded as comfortable, and 1m/s is an acceptable upper limit [1][16]. Therefore, the measured air velocity in the building reached the standard.

To further clarify this issue from occupants' perspective, the residents' vote to indoor air movement in summer was statistically calculated. Below is the question in the questionnaire:

Air movement in summer							
Too draughty	<input type="checkbox"/>	<input type="checkbox"/>	<input type="checkbox"/>	<input type="checkbox"/>	<input type="checkbox"/>	<input type="checkbox"/>	Too still

Figure 77 shows the results and the fitted line. In a 7-point scale, 1 means windy and 7 means stuffy. It can be found that more people felt it stuffier rather than windier. There is subtle difference between floors, but it is not significant.

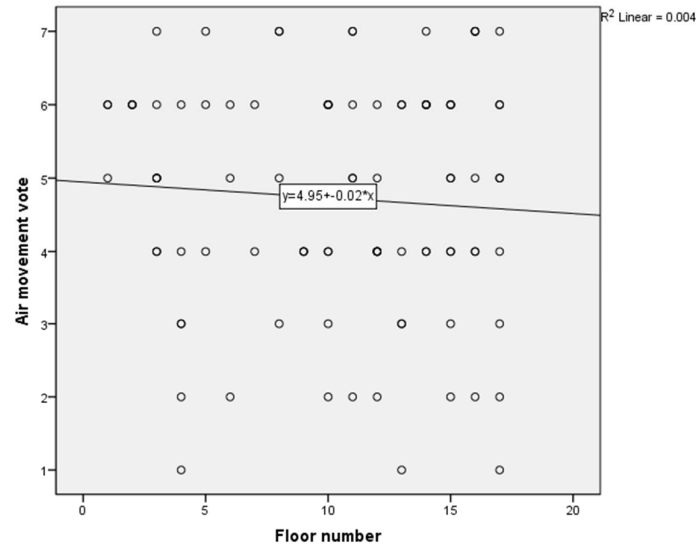

Figure 77: Indoor air movement vote graph

Table 18 shows detailed statistical results of the indoor air movement vote. In total, 94 interviews living on different floors answered this question. On average, the indoor air movement vote result is 4.72, which is neutral but a bit stuffy.

Table 18: Indoor air movement vote statistical results by floor

Floor number	Mean	N	Std. Deviation
1	5.67	3	.577
2	6.00	3	.000
3	5.14	7	1.069
4	3.17	6	1.722
5	5.67	3	1.528
6	4.33	3	2.082
7	5.00	2	1.414
8	5.50	4	1.915
9	4.00	3	.000
10	4.63	8	1.598
11	5.33	6	1.862
12	4.13	8	1.126
13	3.83	6	1.941
14	5.57	7	1.134
15	4.56	9	1.424
16	5.14	7	1.952
17	4.33	9	2.000
Total	4.72	94	1.602

B. Simulation Results Analysis

As mentioned in Section 4.1, three different cases are simulated. Like section 5.3.1, the air velocity will also be analysed for the different cases in this section.

Case1: Extractor+ Ventilation Grill

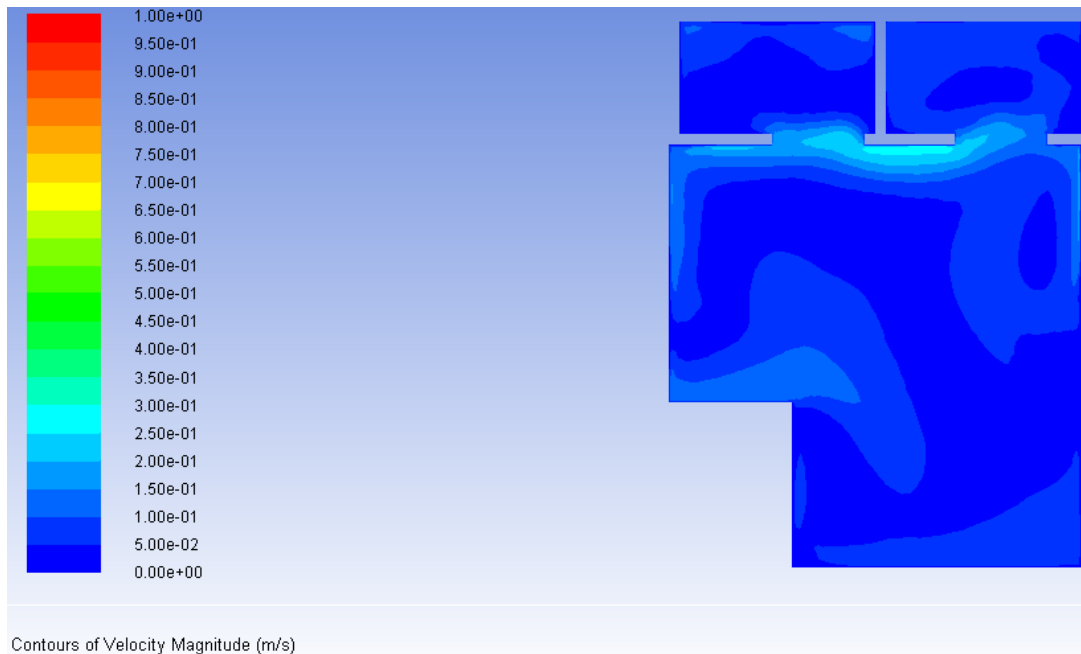

Figure 78: the air velocity contours for case1- Horizontal

In Figure 78, it can be found that the contours are dark blue in largest part of the room, which means air velocity is very low. Since the extractor is designed just for ventilation, but not for cooling, it is not surprising. The air velocity is less than 0.1m/s in the center part of the room, where the researcher also did the on-site measurements. Low air velocity can hardly provide extra cooling feeling. On the other hand, there is also no need to worry about draught problem.

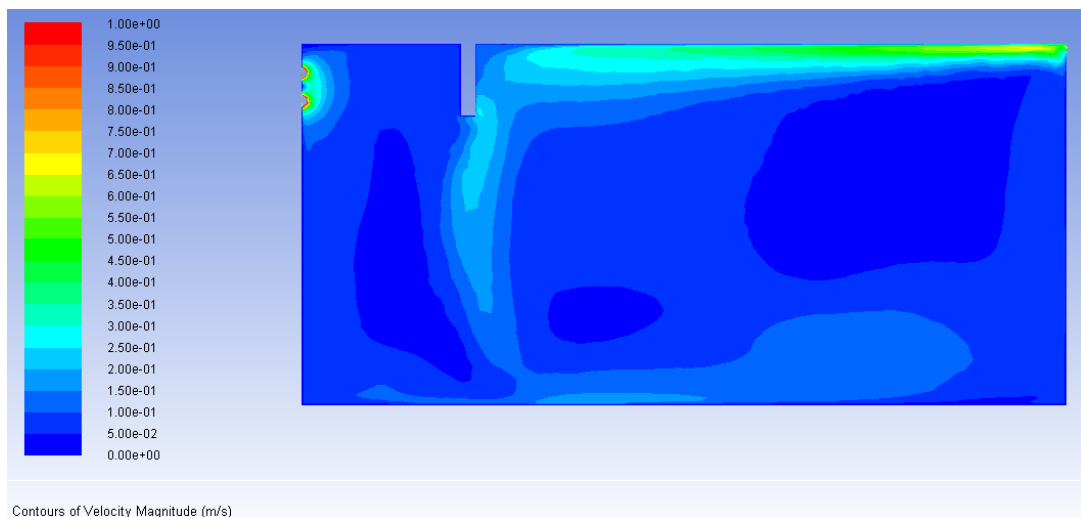

Figure 79: the air velocity contours for case1- Section A

The air velocity contours in Figure 79 explain why the temperature is lower in the ceiling part. The air velocity is higher in the ceiling part, which can bring more fresh cold air. The air flows into the room until it is obstructed by the wall on the door, and then it flows down. All the areas with high velocity are out of residents' reach. The high air velocity on the left is caused by the small outlet of the extractor, and the amount of air is also very small.

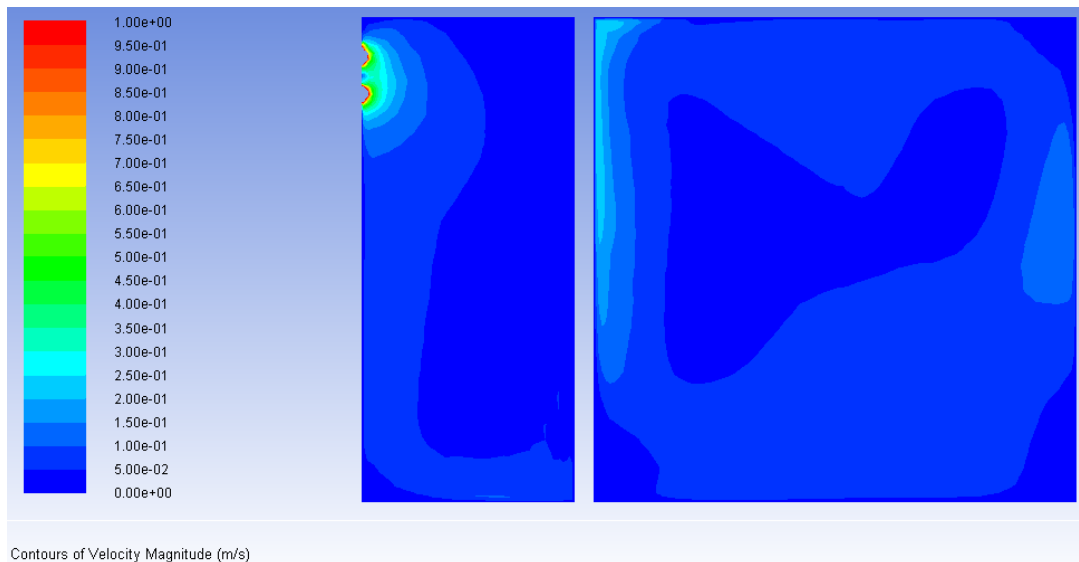

Figure 80: the air velocity contours for case1-Section C

Figure 80 shows a similar situation. The air velocity is usually less than 0.1m/s except for the extractor part. There is no extra cooling effect for the residents by means of such low air velocity.

Case2: Extractor+ Ventilation Grill+ Window (Open from the bottom)

The temperature distribution in case 2 is found to be much better than in case 1, and so is the air velocity distribution.

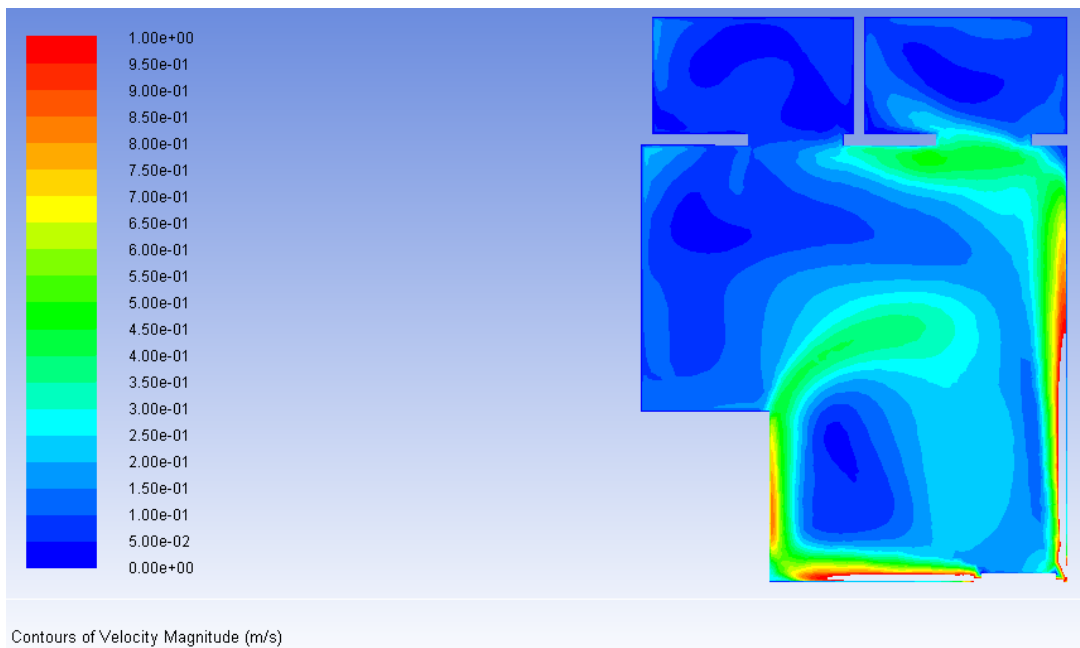

Figure 81: the air velocity contours for case2- Horizontal

As shown in Figure 81, the air velocity in case 2 is much higher than in case 1. The air velocity on the path of the wind can be higher than 1m/s, which is enough to cause discomfort. Fortunately, the area with high velocities are close to the wall, which is not the main activity area for the residents. The distribution is not so uniform. Despite these area, the air velocity in the rest area is still less than 0.15m/s.

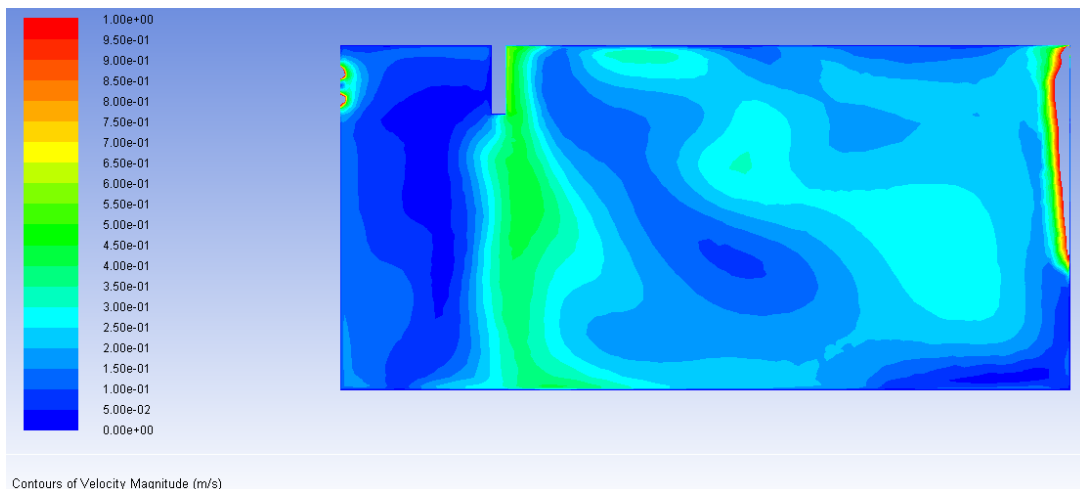

Figure 82: the air velocity contours for case2- Section A

From the air velocity contour Figure 82, we can see the air flow pattern in the vertical section. Although the air velocity is very high at the inlet parts, it drops dramatically in a short distance. The air velocity can reach around 0.5m/s at the door to the toilet, which plays a role of “bottleneck” in the room. Since all the air has to pass through the door, the air velocity there increases due to the accumulative effect. Generally, the air velocity distribution is satisfying.

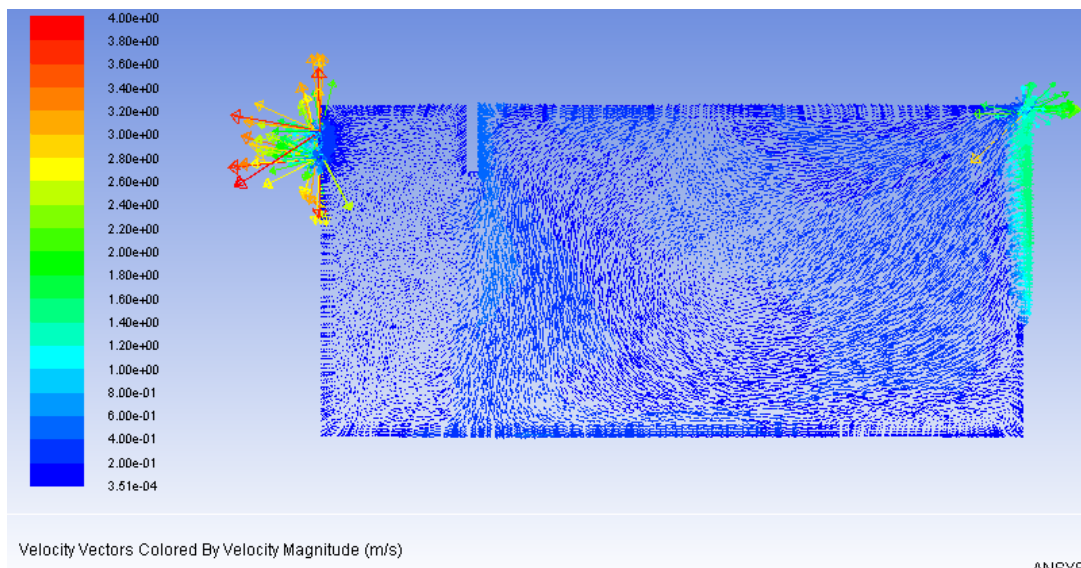

Figure 83: the air velocity Vectors for case2- Section A

To make it more clear, we can refer to the velocity vector graph Figure 83. At the ventilation grille, there are many vectors directing outside the room, while there is also a few vectors directing inside the room. It means that the ventilation grill is mainly a outlet in this situation, while there is also inward air at the same time.

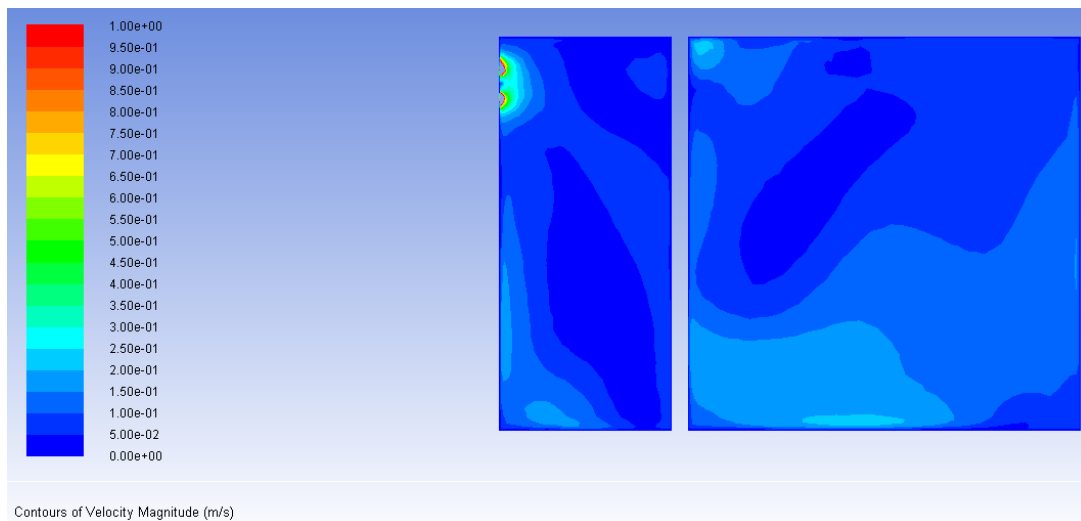

Figure 84: the air velocity Vectors for case2- Section C

Figure 84 clearly shows the air velocity pattern in the inner part of the room. In general, the air velocity is less than 0.2m/s. From Figure 4, it can be found that a air velocity of 0.2m/s can hardly provide any cooling effect. Since the inner part is usually occupied by a bed, it is not a problem that the air velocity is low.

Case3: Extractor+ Ventilation Grill+ Window (Open from the side)

In case 3, the air velocity is much higher than that in other two cases. To show the contours more clear, the upper limit of the air velocity is always set to be 1m/s. The void(empty) part close to the window means that the air velocity is more than 1m/s, which is out of the comfort zone.

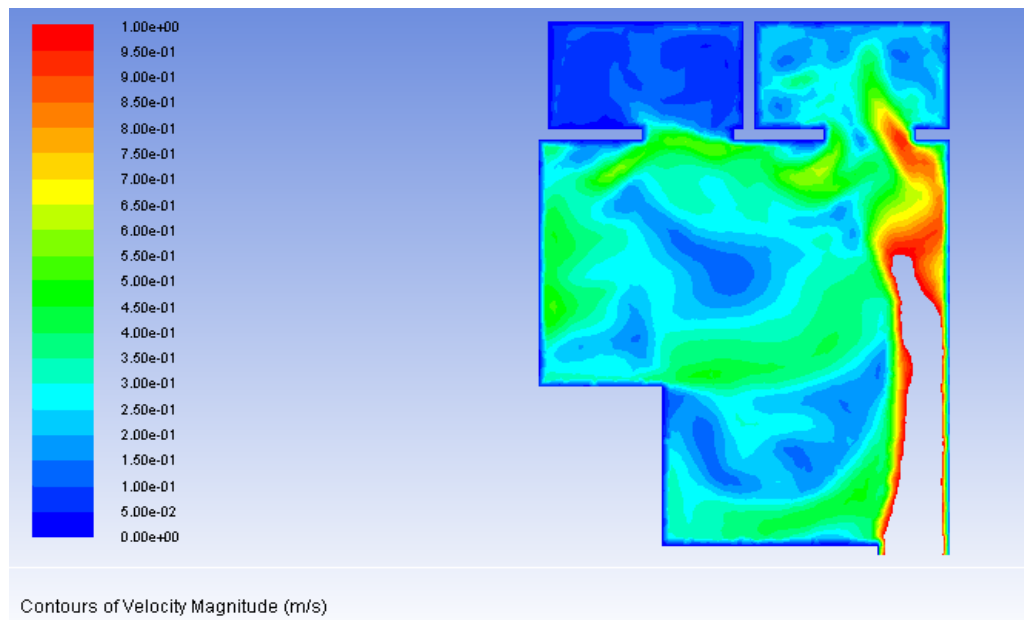

Figure 85: the air velocity contours for case3- horizontal

From Figure 85, it can be found that the air velocity reaches 0.5m/s in most areas in the room. The direct wind even makes the indoor air velocity exceed 1m/s in the area close to the window. This is already higher than the upper limit of 1m/s.

Though it is assumed that the natural wind blows into the room perpendicular to the wall with a velocity of 1m/s, it can be different in reality. If the wind blows in another direction, the air velocity in the center part will increase to higher than 1m/s. Though some people can endure it, it is still out of the comfort zone.

However, as shown in Figure 77, only a few interviewees complained about high air velocities in the room, while most of them thought their rooms are too stuffy in summer. Moreover, a few people mentioned that they need an extra fan in summer. Since the natural wind is difficult to simulate precisely in this scale, we just try to give a rough idea about this issue.

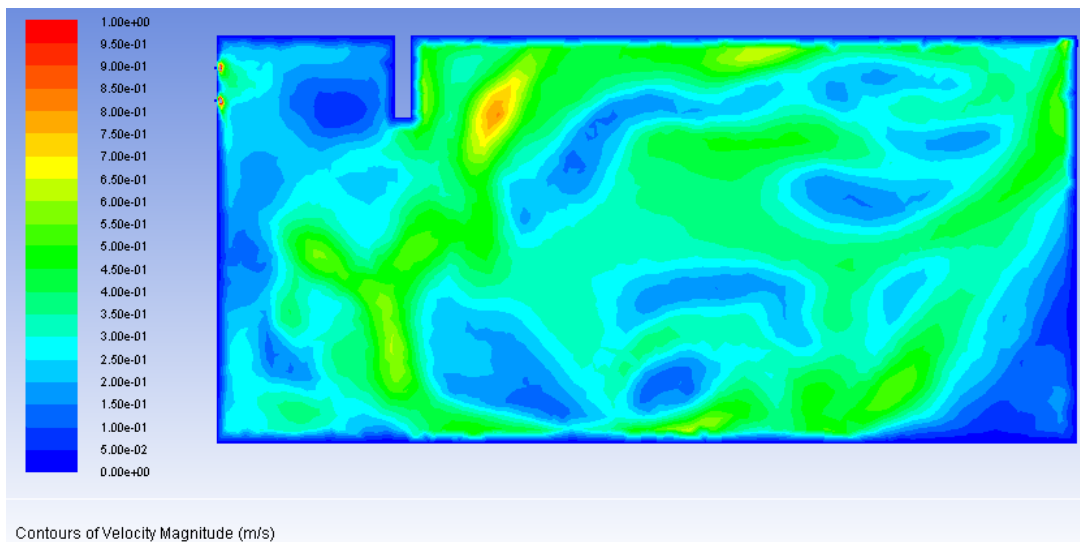

Figure 86: the air velocity contours for case3- Section A

From Figure 86, it can be found that the air velocity is distributed in a chaotic way. The air velocity is around 0.5m/s in most areas, which is very ideal from thermal perspective. However, this is a unstable pattern, which might change in reality.

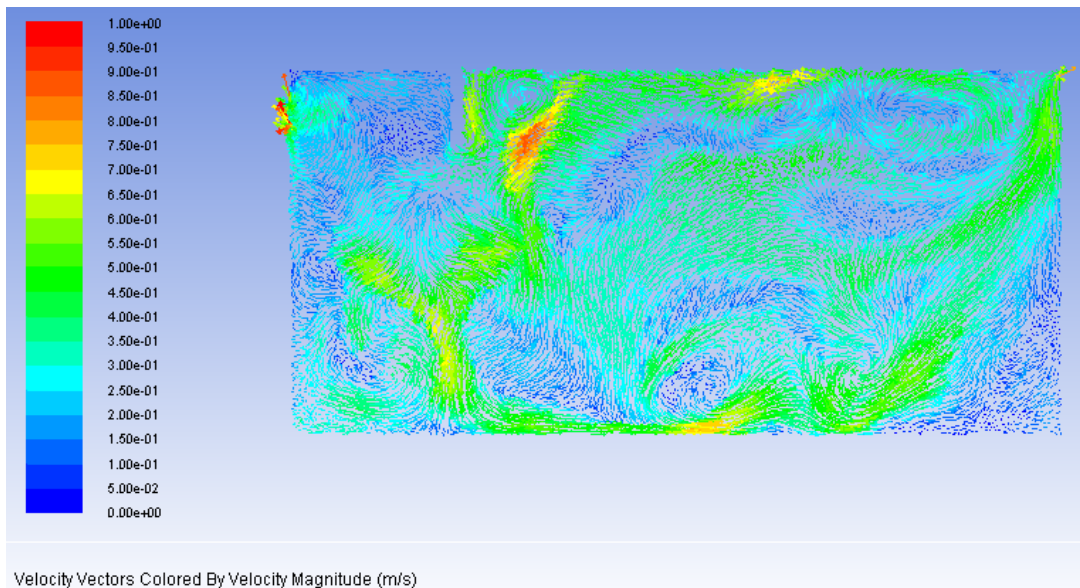

Figure 87: the air velocity vector for case3- Section A

From Figure 87, much turbulence can be found in the air velocity vector graph of the room, both near the ceiling and the ground, which cause the chaotic air velocity distribution. Turbulence can exaggerate the feeling of draught, which can cause discomfort to the residents[27]. It is hard to judge whether the turbulence is positive in this case, since extra cooling and more turbulence appear at the same time.

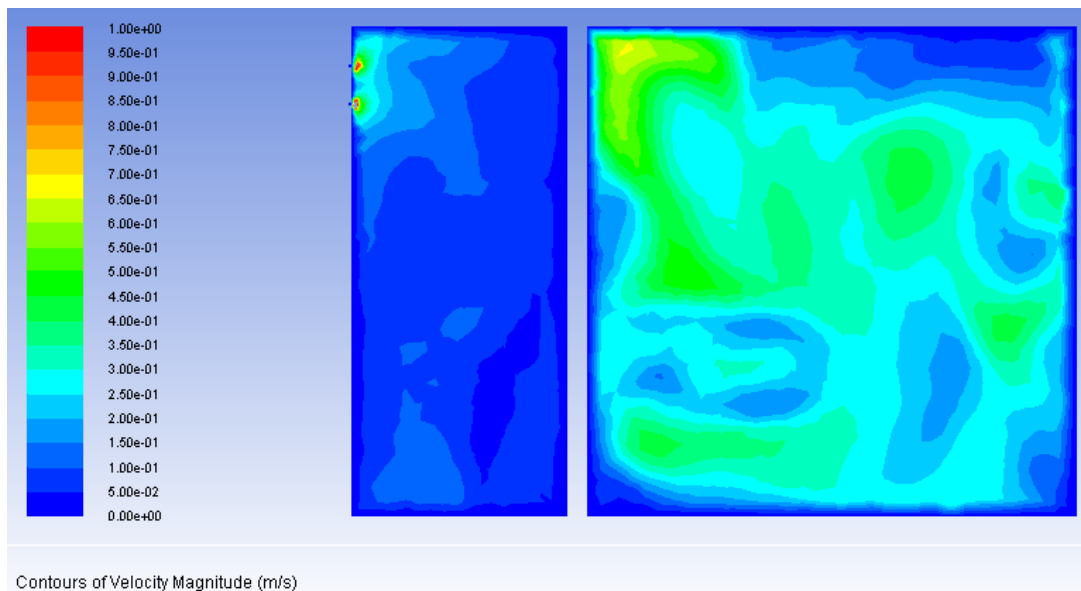

Figure 88: the air velocity contours for case3- Section C

Figure 88 shows the air flow pattern in the inner part of the living room of Case 3. In most areas in the living room, the air velocities range from 0.2m/s and 0.4m/s, which can lower the residents' thermal perception by 1°C. This is favourable for cooling.

5.3.3 Summary and Conclusion

In the three cases of CFD simulation, the indoor temperature was found to be most ideal in case 3 and worst in case 1, and the indoor air velocity can also be effectively increased by means of changing the status of the window. Therefore, the thermal comfort can be really well if the windows are used properly.

The closer to the window, the more is the area influenced by outside weather. The air velocity in the inner part of the living room was found to be lower than other parts in the room.

When natural wind is dominating, the distribution of temperature and air velocity tends to be chaotic. This indicates the possibility of turbulence in the room. However, the difference was not found in the measurement. The temperature difference in different rooms was never more than 1°C.

CHAPTER 6. Discussion and Refurbishment Possibilities

In Chapter 5, all the results of the field study and the simulation are preliminarily analysed. In this chapter, these data will be further discussed to draw conclusions, and formulate recommendations for possible refurbishment in the future.

6.1 Thermal Comfort Distribution

The comfort level can be influenced by different parameters. In this section, these parameters will be divided in to residents' parameters and spatial parameters.

Residents Classification

Residents can be classified by many parameters. Therefore, hereby nationality and gender are analysed to check whether they have statistical relevance to the thermal comfort.

1) Gender

As shown in Table 6, the average general comfort level of females is always lower than that of males. When it comes to thermal comfort, the conclusion is similar. Relatively, males tend to feel the environment warmer than females, as shown in Table 7. However, t-test showed that thermal comfort level is not statistically closely related to gender. The hypothesis that women are more unsatisfied in the residential building was not verified in this case study.

It has been proved by many researches all over the world that females were found to be less satisfied than males with room temperatures during the winter season, but more satisfied with room temperatures during the summer season [52][53][56].

It seems that the case study in this building contradict with other researches all over the world. However, it should be noticed that the sample size of different

genders and different nationalities are not equal, which can cause inaccuracy to some extent.

2) Nationality

The second affecting factor researched in this research is nationality. Among the three classified groups of interviewees, Chinese residents were found to be most satisfied with the general comfort level. Indian residents and Greek residents are generally unsatisfied. When the question is precisely about thermal comfort, the difference in thermal comfort vote still can be around 0.64 on a 7-point scale. Chinese interviewees were still found to be most neutral to the temperature, while Indian and Greek interviewees felt the rooms hotter. However, t-test showed that thermal comfort level is not statistically closely related to nationality. Therefore, the difference cannot be directly related to the nationality. However, how can we explain this difference?

Since the thermal neutral temperature in Greece and India is higher than that in China, it is interesting that Greek people and Indian people are more sensitive to high temperature than Chinese people. To figure out the reason, the researcher discussed this with the Indian residents there.

“Because there is air-conditioner in India!”---Munjal Salva

This is a typical response when the researcher asked the Indian people about this question. Since the temperature in India is always so hot, people prefer to have air-conditioner in their room in India, if they can afford it. Students who can study abroad might come from relatively richer families. Therefore, air-conditioner should be common for them to use in India in summer.

For Greek people, the problem might be more about humidity. In Greece, the humidity is usually very low in summer, which makes most of the Greek residents find the summer in Netherlands too humid. This was verified by several residents who discussed with the researcher. Since humidity is highly related to thermal comfort, the difference in thermal comfort perception is not surprising.

Another important reason might be about culture. In Chinese culture, complaining is not so appreciated as enduring in daily life. As a consequence, people might prefer to respond more positively to the questions, though they might feel hotter in fact. According to the research by Igor and Sofia in 2006[63], the thermal comfort level is intertwined with psychological and socio-cultural process, and it is not always accurate to compare the thermal comfort among people from different countries directly.

According to De dear et al [13], the residents' expectation plays an important role in thermal comfort. Since these residents came from warmer areas, they would expect that the summer in the Netherlands is pleasantly cool. When they found that the summer in Netherlands can be hot and humid, which is out of their expectation, they might think that it was too hot.

In conclusion, the thermal comfort perception by people from different countries does differ in this research, but it is not statistically proven yet. Further research about residents with different background is needed.

Spatial Classification

Spatial parameters make a high-rise building different to other kind of buildings. Hereby, three different spatial parameters are discussed.

1) Same corridor

The temperatures at different locations of one outside corridor are usually very close to each other. Due to the sun path, even for the rooms on the same floor and same façades, there can be a radiation difference. As shown in Figure 57 and Figure 58, in the two comparisons of rooms on the same floor and same side, there is no apparent temperature difference found among rooms at the same corridor.

Since the difference at the same corridor is usually less than 0.5°C and there is not an apparently warmer room, the temperature in different rooms on the same corridor can be regarded as the same. This also allows the researcher to use the data in any room at the same corridor to represent the climate data in other rooms.

2) Different Height

The height of the floor does play an important role in thermal comfort. The indoor temperature was found to be highest on the top floor and lowest on ground floor. The temperature in middle floors are intermediate and the temperature difference between each other is not apparent. Residents' perceptual evaluations also showed the same conclusion.

Solar radiation, thermal mass and surrounding can be the reasons for this phenomenon. Compared with other parts of the building, the roof can absorb the most heat from solar radiation, which will lead to higher temperature there. Due to thermal conductivity, the temperature on the top floors can be directly increased. On the other hand, the earth has huge thermal mass, which fluctuates very little in one day. Even at an extremely hot day, the earth can keep absorbing heat from the ground floors in terms of thermal conductivity. As a result, the temperature on ground floor might tend to be lower than other floors, which was observed in the field study. Related research in Southeast Asia also has also proven that the indoor temperature can rise with the height in a high rise building [28][29].



Figure 89: The surrounding of the building

Source: [<https://www.google.nl/maps>]

In contrast to temperature, air velocity didn't increase with the height in this research, which is not in line with the wind gradient theory. Table 15 shows that the wind velocities on different floors were very close to each other. Figure 77 shows that residents on the higher floors higher air velocity in their rooms, but the

difference is very little. Although the indoor air velocity can be controlled by the residents, it is still related to the outdoor air velocity.

This contradicts to the expectation. As mentioned in 2.3.4, wind velocity increases with the height. According to Wong et al in 2006[28], the residents on higher floors feel higher indoor air velocity in their rooms. Therefore, there should be more significant difference between air velocities on different floors.

The contradiction can be caused by measurement error. The air velocities at different height were not measured at the same time due to the equipment availability. Since the difference between different floors was not great, it is possible that the air velocity just changed in the experimental period. Moreover, the measurement for wind velocity on the outside corridor only lasted 10 minutes for each floor. There is higher possibility to go wrong in such a short period.

The complex surrounding geometry can also be the cause of this phenomenon. The building is located in the city area, which can be seen from Figure 89. In urban area, there are many street canyons, which leads to many turbulence and the air velocity can be more complicated. According to Eliasson et al in 2006[58], wind flow within the canyon may change rapidly, while wind velocity closely follows the log wind profile law when above the canyon. Since there are also high-rise buildings nearby, the wind pattern can be affected a lot even on high altitude.

3) Different Orientation

The orientation of the façades also has much influence on the thermal comfort of the residents. As shown in Figure 62 and Figure 63, the temperature in the rooms on west side is lower than the temperature in the rooms on east side. This contradicts the expectation. According to the research by Dahlan in 2008[29], the temperature on the west side is usually higher than that on the east side. The west façade of the researched building does not face directly west, but with an 18.5° deviation to south. Since the Netherlands is in the northern Hemisphere, the south

facade actually gains more heat compared with the north one. Therefore, the west should be even hotter.

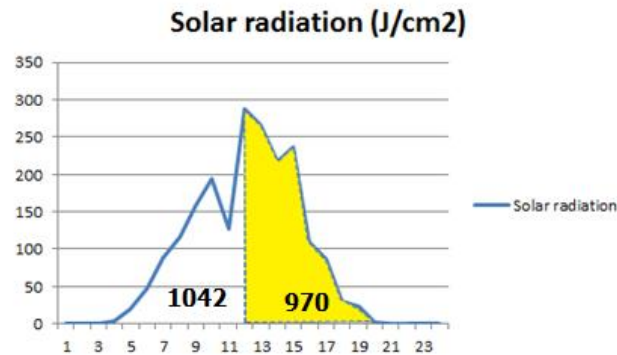

Figure 90: The solar radiation distribution in 1st July

To check the radiation issue, the solar radiation graph on one typical summer day is drawn. According to Figure 90, the maximum solar radiation is stronger in the afternoon, but it doesn't last so long as in the morning. As a consequence, the accumulated heat gain in the afternoon is even a bit less than that in the morning.

Moreover, Residents on the west side might tend to shut the curtain in the afternoon to avoid direct glare, while residents on the east side probably prefer to have some more sunlight in the morning. When the curtain is shut, it will reflect part of the radiation back, which can also reduce the heat gain.

Air velocity on the corridor is also influenced by the orientation. Table 15 shows that the air velocities on the west corridor were apparently higher than that on the east corridor. Since south-west is the prevailing wind direction, this is not a surprising result.

4) Entity of the high rise building

Since both the height and the direction can affect the temperature in the rooms, what is the resultant? As mentioned before, top floors tend to be hot, ground floor tends to be colder, and west façade tends to be colder. Is the ground floor on the west the coldest? Is the top floor on the east hottest?

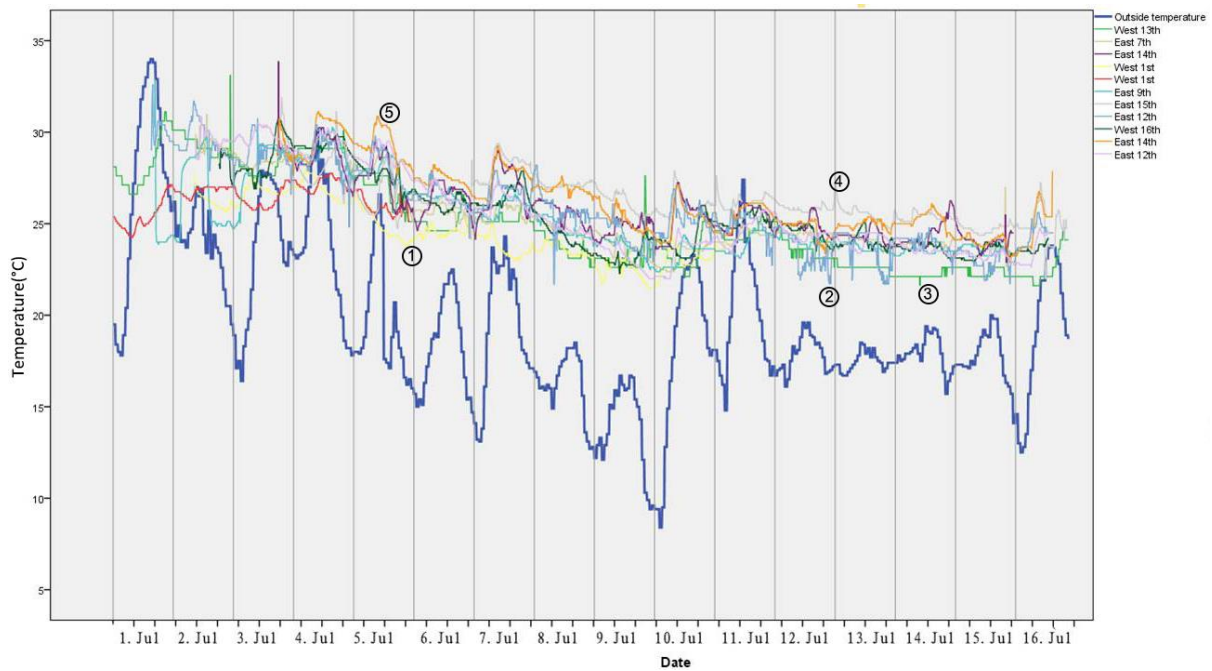

Figure 91: Temperature lines

As shown in Figure 91, the yellow line ①, which represents the room on the 1st floor on the west, is almost always the lowest one among all the lines from 2nd July to 10th July. The orange line ⑤ and the grey line ④ representing the rooms on the 14th and 15th floor on the east are mainly the highest. Apparently, they were the hottest and coolest rooms in the experimental period. The difference between them is around 4-5°C, which is almost the maximum temperature difference between rooms.

However, the behaviour of the residents to control the system is also important. It should also be noticed that line ② and line ③ are the lowest from 10th July to 16th July. They represent east 12th floor and west 13th floor separately. For these two rooms, they are not on perfect locations, but were just cooled down by the residents' behaviour at room level. Compared with other rooms on the same floor, they were still around 3°C lower. Since the orientation and height doesn't make a difference here, the behaviour of the residents is the only "game changer".

4) Room

In a room in the studied building, the thermal comfort level largely depends on the status of the window. Since the rooms are not large, single-sided ventilation is able to provide enough fresh air and cooling in the assumed cases. If the window is

closed, the amount of fresh air is very limited, and the thermal comfort level is not influenced by the outdoor air very much. When the window is open from the bottom, which is kind of half-open status, the thermal comfort level falls in between the other two modes.

Due to safety concern, residents would not to open the window at night, which makes it impossible to utilize night ventilation to cool down the room. That might be the main reason why most rooms stayed hot for 4 days after 1st July, even if the outdoor temperature is already not hot anymore.

The closer to the window, the more influence there is from the outdoor air. The temperature tends to be higher and air velocity tends to be lower in the inner part of the room. Due to the thermal mass and obstruction of the room itself, the natural wind tends to become warmer and more still in the flowing process in the room.

Natural wind might make the residents feel draughty when the window is opened from the side. According to Fanger and Melikov [27], high turbulence intensity had a significant impact on the occurrence of draught sensation. From Figure 87, it can be found that there can be turbulence all over the room. However, no resident complains about draughty in the room.

Conclusion

Thermal comfort and related parameters' distribution in the researched building is discussed in this section. In general, the comfort level is satisfying except the 1st day and the following 4 days. Difference in different groups of people was found to be not really statistically related, while the difference between different parts of the building was verified by the on-site measurement.

In the next section, the cause of discomfort for residents are analysed in detail.

6.2 Problem Analysis

The thermal comfort level has been assessed in section 5.2.1, and it was found that the indoor temperature was within the comfort zone most of the time during the experimental period. However, the indoor temperature stayed high for 4 days after the 1st July was. According to the questionnaire survey, high temperature is the main problem that cause discomfort in summer. Therefore, the focus of the problem analysis is to improve the thermal comfort in summer.

As analysed in section 6.1, the indoor temperature in different rooms can differ 4-5°C, which is enough to create a more comfortable room even at the hottest day. Though the rooms with a good location have higher possibility to be cooler in summer, other rooms can also be made cool by means of appropriate ventilation strategies by the residents.

Because of the thermal mass, the temperature of the construction of the room changes much more slowly than the air temperature. The air temperature gained from the simulation is not the same as the temperature of the building itself. A hot wall can keep radiating heat, which will affect the residents' perception and heat the room. As a result, the room might turn hot again when the window is closed. At night, most residents would close the window for safety reasons. Since the outdoor air temperature is the lowest in the evening and night, they will lose the chance to utilize night ventilation. As a result, the temperature of the whole building cools down more slowly in this situation.

When the window is open, the natural ventilation can effectively cool down the room. Though the wind velocity can be relatively high in some periods, the residents don't really feel it in reality. However, the residents cannot really open the window freely, even when it is very hot in the room, and they do want more wind. The main hindrances are privacy and safety.

Privacy and safety are closely related aspects. Due to the big window on the corridor, the residents usually feel that the passers are staring at them, which they perceive as

unsafe and harmful to privacy. Figure 52 clearly shows that the area is not so safe in reality. Moreover, the design of the window makes residents feel unsafe.

There is a opaque film on the window to prevent unfriendly stare, which is shown in Figure 92. However, 60 of the 205 rooms don't have such a film, and the films on the windows of the rest rooms are not complete anymore. In some rooms, the film only covers part of the window, which is not enough to effectively protect the residents' privacy. How come?

"The films turn yellow in around 2 years. Then they will not be reinstalled unless residents ask for that."

said by the caretaker from DUWO(the owner and managing company of the building). Around 1/3 of them are not installed properly nowadays. However, privacy films with good quality doesn't turn yellow. It is not a real excuse for this problem.



Figure 92: The photo for the windows with and without films

Since the sun-visual privacy film on the window doesn't work so well, that does affect residents' behaviour to some extent. If they want to protect their privacy, the only way is to shut the curtain. When the curtain is shut, it is difficult to use the window properly due to the obstruction of curtain. Consequently, the wind cannot help to cool down the room in this situation.

Conclusion

Thermal comfort level can be largely improved if the windows can be used freely. However, due to the privacy and safety problem, the residents cannot do that as they want. Therefore, the key of the thermal comfort problem is to solve the dilemma between opening the window and exposure to strangers. Solutions and recommendations are given in the next section based on this dilemma.

6.3 Solutions and Recommendations

In chapter 5, the results are analysed in building scale and room scale, which provides us deeper understanding into the thermal comfort in a high-rise building. To respond to the findings, the solutions are also given in two different scales. Strategic recommendations are given at building scale, and more detailed design possibilities are discussed at room scale.

6.3.1 Building Scale Strategy

As discussed in section 6.1, thermal comfort distribution is not the same in different parts of a high-rise building. As a consequence, different strategies in different parts can help to improve thermal comfort more effectively. Figure 93 shows the thermal comfort distribution in the researched building. Red means hot, blue means neutral and yellow means warm. Different strategies are provided for these three zones.

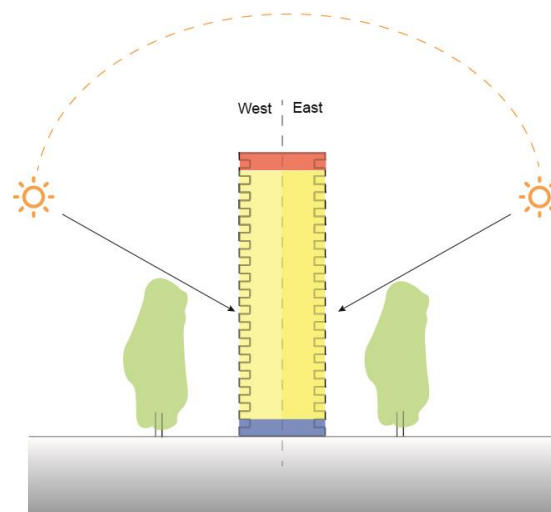

Figure 93: Thermal comfort distribution in the researched building

First floor

The temperatures in the rooms on the first floor were found to be in the comfort zone even on 1st of July--an extremely hot day with an air maximum temperature of 34°C. If the rooms there can keep cool in such weather, it can definitely keep cool in other days in summer. Therefore, the best solution for this floor is just to maintain the status quo.

Top floors

Top floors are hottest in the researched building. There must be some extra solutions to improve the thermal comfort there in summer.

As been discussed, solar radiation on the roof makes the top floors hotter than other floors. Therefore, the extra heat on the roof should be reduced or isolated from the building. Figure 94 is the photo of the shading roof of Menara UMNO in Malaysia. It was designed to deal with the strong sun radiation in Southeast Asia, and it has been proven that it works very well.

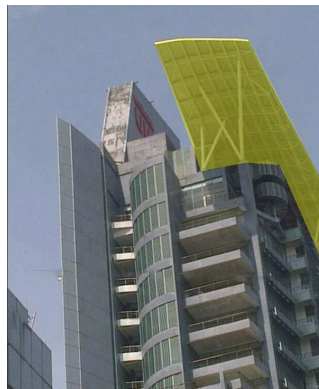

Figure 94: The shading roof of Menara UMNO

Source:[<https://weehingthong.wordpress.com/>]

As shown in Figure 95, if an extra insulation roof is added, then the temperature of the top floors can be lowered to the temperature as that in middle high floors. However, the thermal comfort level is still not satisfying in that case. Therefore, more solutions are needed.

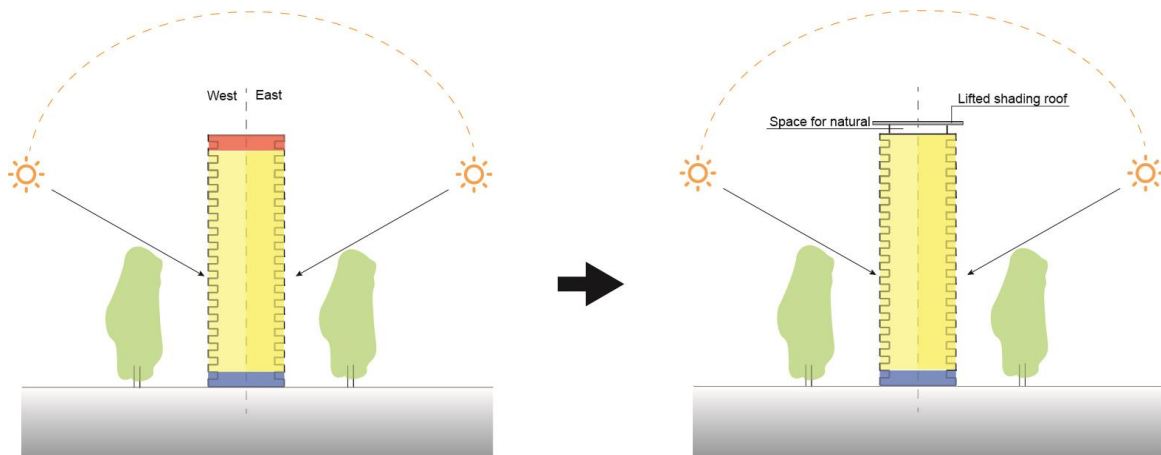

Figure 95: Comparison of the thermal comfort before and after renovation

Middle floors

The temperatures in the rooms on the middle floors could exceed the maximum comfort temperature in hot days, which needs further improvement.

As discussed in section 6.1, the thermal mass of the building prevents the rooms to be cooled down rapidly. If the total heat gain is controlled, the whole building can be cooled down. Then it doesn't matter whether the residents open the window or not. To reduce total heat gain, the easiest way seems to be adding external shading system.

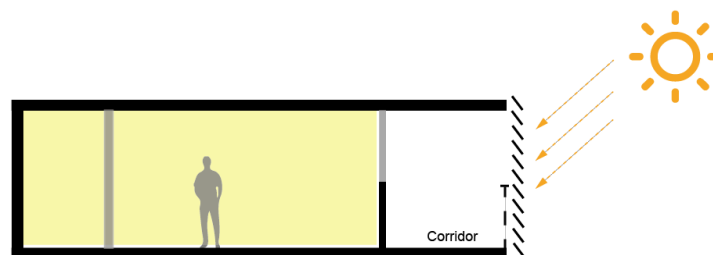

Figure 96: The principle of an external shading system

The disadvantages of this solution are also apparent. This method cannot help to solve the privacy problem. The residents, who don't open the window due to the privacy problem, will still do that as usual. On the other hand, a fixed external shading system will block the view and the heat in winter. The hot days usually doesn't exceed 15 days, while the cold winter lasts months. In the long winter in the Netherlands, sun light is very valuable for the residents, and that is why there are so many Dutch houses with huge window. Therefore, it is not wise to obstruct the sun

light as a strategy. Instead of that, room scale design can help to solve the thermal comfort problems more flexibly.

6.3.2 Rooms Scale Design

As mentioned in section 6.3.1, room-scale redesign is needed for all the rooms except those on the 1st floor. Based on the analyses in section 6.1 and 6.2, it can be found that privacy does play an important role in the thermal comfort issue in the building. The main goal is to get a balance between privacy and thermal comfort.

Solutions are classified by A, B and C. All of them can be chosen separately, but the most ideal way from thermal comfort perspective is to combine them together. After the introduction of these three solutions, an integrated solution will be explained.

A. Privacy-protecting film/curtain

Since it is already known that visual privacy film can definitely help to relieve the privacy problem, applying it in all the rooms is the most practical and easiest solution. The cost to install visual privacy film is low, which is also cost effective.

It should be noticed that this solution can only relieve the unsafety feeling to some extent. There might be still some residents who prefer to shut the curtain and the window directly. Therefore, if we want to solve the problem better, further measures should be taken to deal with the privacy and safety issue or to improve thermal comfort level.

Moreover, a fixed film on the whole window will block the view outside, which is not pleasant. Another possible solution is to apply adjustable shading system. Figure 97 shows a window with adjustable shading produced by VELUX Company. This kind of design provides more flexibility for the residents, which makes it possible for them to adjust the system as they want.



Figure 97: Velux window with adjustable shading system

Source: [<http://www.mgmtimber.co.uk>]

B. Extra fan for the residents

As has been proven all over the world, a fan can effectively help to improve the thermal comfort [15]. This solution was also mentioned by many interviewees, when they were talking with the interviewer. Some residents already have one in their rooms.

Installing a fan is very practical. The cost is relatively higher than just a window film, but it is still lower than any refurbishment to the window or facade. The fan is also very handy to be installed. If it is a moveable one, it even doesn't need to be installed. This can definitely reduce more cost in labour.

The disadvantage is that a fan doesn't help to cool down the building thermally. According to Son.H Ho[60], a ceiling fan can sometimes even increase the indoor temperature, since the circulating the heat around the room instead of moving it to the outlet. However, owing to the wind velocity created by the fan, the PMV value decreases toward cooler side and thus over-compensates the temperature rise.

C. Refurbishment

If it is possible for the ventilation system work well while the privacy and safety is protected, the residents will be glad to use it without worry. Therefore, the key point is how to balance them. Hereby, two solutions are given to deal with the thermal comfort problem.

H window

H window is a flexible window system. As shown in Figure 98 a), the H window can be opened from the top with a small angle. Such a small cavity is harder for the passer-by's to look through, which is good in privacy protection. As shown in Figure 98 b), it can also be opened very large.



Figure 98: H window

Source: [<http://www.thehwindow.com/>]

The effect of natural ventilation depends on the status of the window. However, there is a contradiction between efficiency and safety. Larger opening can provide more cool air, but it also increases the risk of burglar. Therefore, the flexibility is another reason to choose this window system.

Ventilator

It is possible that some residents always feel unsafe, when the window is open. In this situation, the only solution is to enhance the air flow mechanically. Therefore, a ventilator can be installed to provide more natural air at hot summer night.

Integrated Solution

All these solutions can contribute to better thermal comfort in this building. The most ideal way is to combine an adjustable window curtain and new window system, and provide fans for everyone as an extra option.

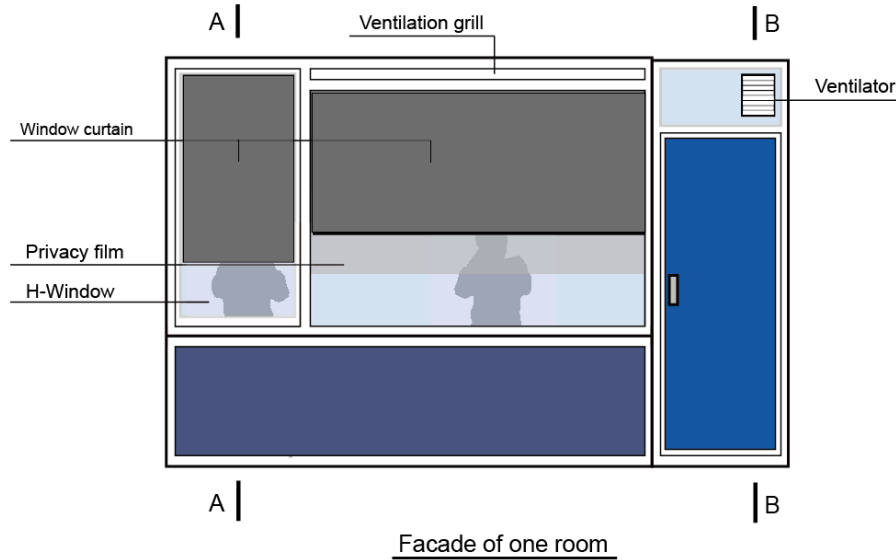

Figure 99: Room façade

Figure 99 shows the new façade of the room. From the façade, it can be seen that the “window curtain” attached on the window can be easily adjusted to provide privacy protection. A new ventilator is installed, and the inlet is on the top of the door. Rectangular duct is chosen for the ventilator, since the whole façade is composed on rectangular. The façade looks more homogeneous in this way.

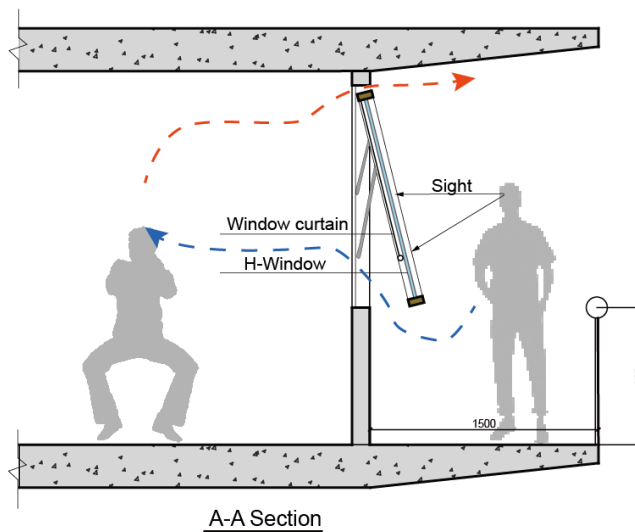

Figure 100: Section A-A

From the section shown in Figure 100, we can find that the air flow can enter the room easily when the curtain is closed. Window is opened from the top, which largely reduces the chance for the passer-by's to look into the room through the cavity between the window and the window frame. The curtain is installed on the window, so it does not obstruct the airflow even if the residents completely shut it. As a result, even at night, residents can enjoy natural light without worry about offending to their privacy.

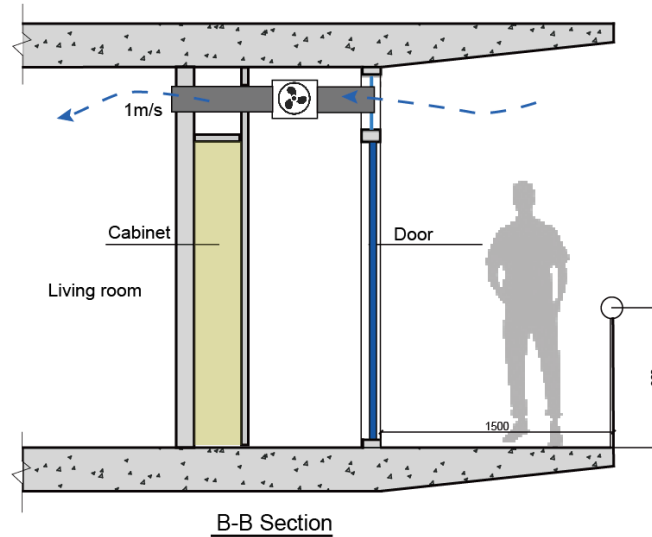

Figure 101: Section B-B

Figure 101 show the B-B section. It can be seen that a fan is installed between the outdoor and the living room. The fan is installed outside the living room, so the noise level can be lowered to some extent.

Conclusively, compared with the old system, only the window and curtain need to be replaced, and the ventilator can be installed easily without great change. Therefore, it is also a very handy and effective solution.

CFD Verification

To assess the effect of the H window, two cases of CFD simulation was carried out. It simulates two possible choices for the residents at night. The main results are shown below, and the rest results are shown in Appendix E.

Case 4 simulates the minimum opening status, as shown in Figure 98. In Case 5, the window is assumed to be completely closed, since it's assumed that the owner really

cares about safety. In this case, he/she can still use the ventilator to get the room cooled down.

On-site measurement is not possible at this stage. Therefore the boundary condition of case 4 is assumed to be the same as introduced in Chapter 4. For case 5, the size of the ventilator is set to be 20cmx30cm, and the air velocity at the inlet is set as 1m/s.

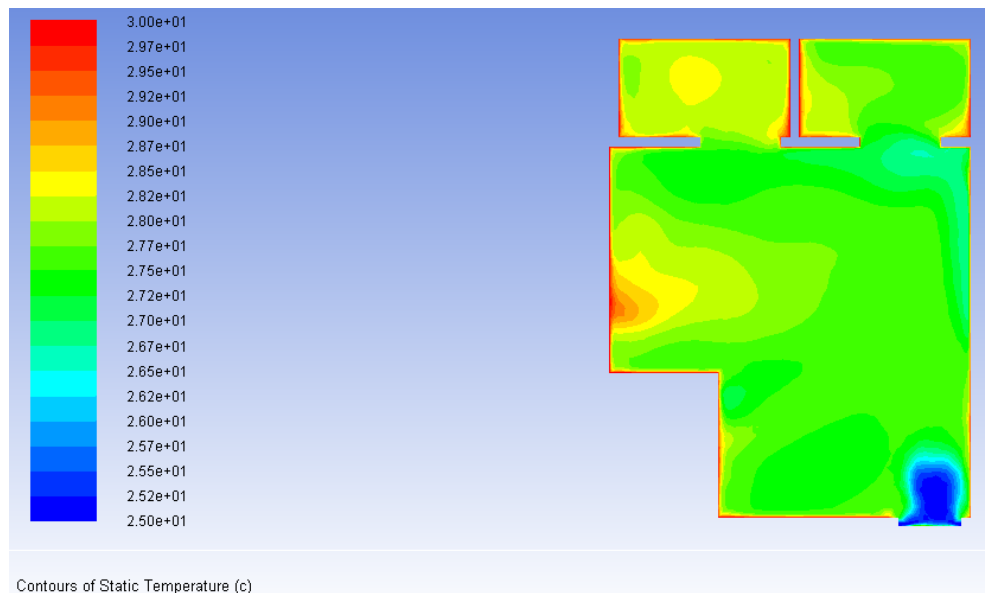

Figure 102: Case 4-Temperature contours

Figure 102 shows the temperature distribution in case 4. It can be found that the most parts of the room are green, which means that the temperature there is around 27°C. That is already in the comfort zone.

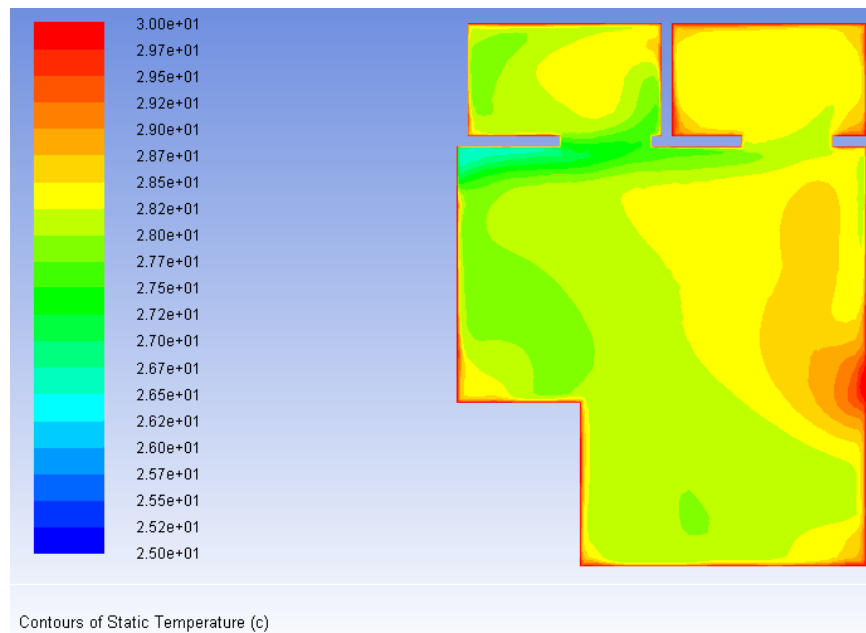

Figure 103: Case 5- Temperature contours

Figure 103 shows the temperature distribution in case 5. It can be found that the most parts of the room are yellow-green, which means that the temperature there is around 28°C. It is not as good as the case with window open, but it is still much better than just close the window. Since the temperature can be decreased in this way, the temperature of the building itself can be lowered more rapidly at night in this way. As a result, the temperature of the rooms can also be lowered in return.

CHAPTER 7. Conclusions and Recommendations

In this chapter, the research questions will be answered again briefly to finish this research. Moreover, recommendations for further research will also be given as a reference for the possible researchers in the future.

7.1 Conclusions

With the field study and ANSYS Fluent program simulation, a Dutch residential high rise building was researched to analyse the thermal comfort level with a hybrid-ventilation system during summer condition. In total, 96 residents were interviewed and plenty climate data was recorded during the 2-week experimental period. To better understand the indoor air pattern, 3 models for CFD simulation were also built. Based on all these research, we got the conclusions about the thermal comfort level in a naturally ventilated high rise residential building.

Main Research Question:

How can we naturally ventilate a high rise residential building with good thermal comfort?

Thermal comfort in a high rise residential building is closely related to the spatial location, the background of the residents, and the status of the ventilation system. To provide better thermal comfort, all these factors should be considered simultaneously.

Sub Research Questions:

1) How do residents really feel in this building?

The factors related to thermal comfort follow the rules below:

- **Residents with different gender might have different thermal perception.**

On average, females tend to feel the environment colder and less satisfied, while males are on the contrary. However there is not statistically significant relevance.

- **Residents from different countries might have different thermal perception.**

Compared with residents from cooler areas, residents from warmer areas don't really prefer higher temperature. On the contrast, they were found to prefer lower indoor temperature in the research. However, the difference is not really significant from statistical perspective.

- **The air velocity doesn't increase with the floor height.**

Due to the complex geometry Compared with the air velocity on the ground, the air velocity on the top floor is even lower. As a result, there is not extra natural ventilation driving force on higher floors.

- **The temperatures in different façades vary with the direction.**

The temperature in the rooms on the west side was found to be usually colder than that in the rooms on the east side. The difference can be around 1-2°C.

- **The temperatures in different floors do change with the height.**

The temperature in top 2 floors was found to be relatively higher. At the same time, the temperature on the ground floor is apparently lower than that on the floors in the middle. In the middle floors, the temperature is positively correlated to the height. The difference between the top floor and the 1st floor can be around 1-2°C.

- **Exact temperature and wind pattern in the room depends on the weather and status of ventilation system.**

In the room, the temperatures are almost the same except the area close to the window. The temperature close to the window and ventilation grill falls in between the outdoor temperature and the indoor operative temperature. The larger the opening is, the more cooling effect can natural wind provide.

2) What Is the Main Disturbance Affecting Residents' Thermal Comfort in the Naturally Ventilated High Rise Buildings?

- In the building in this research, the main problem affecting thermal comfort is that it is usually too hot in the rooms in summer. However, the real problem is that the residents cannot open the curtain and window as they want, because they feel it

unsafe or their privacy is offended if they do that. The dilemma between getting natural wind and privacy protection is the key issue in the thermal comfort problem of this building.

3) How Can We Improve the Thermal Comfort by Natural or Passive Solutions?

- At building scale, different strategies are needed for different parts of a high-rise building, and this can affect the form of the building.
- Good thermal comfort can be realized by sophisticated window system and appropriate privacy film in most of the days in Netherlands in summer, but an extra mechanical ventilator can makes it more acceptable people who is more sensitive to safety.

7.2 Recommendations and Further Research

This research has provides a rough idea about how the thermal comfort level is distributed in a high rise residential building, in large scale and small scale. However, there is still further research can be done about this topic in the future.

Field Study in Other Seasons

The field study of this research is carried out in summer. The interviewees may hold different opinions about the thermal comfort level in the building, when they are really in winter. The temperature distribution can also vary in another season.

In winter, the outdoor temperature is usually much lower than the indoor temperature in Netherlands, which is on the contrary to the summer case. If measurements can be carried out in winter, we can probably find out the difference of the distribution in winter and summer.

Field Survey in Other Types Climate

Climate type is vital when designing a building with natural ventilation. In a different type of climate, will the thermal distribution different?

The climate type of Netherlands is temperate maritime climate. The research in another climate type will help us to understand how high rise buildings react to different climates.

Field Study in High Rise Buildings with Different Forms

The shape of a building can definitely affect the thermal comfort distribution. However, in the research, we only researched one basic shape: slab-shape apartment building with 17 floors.

Due to the material strength limitation, most high rise buildings cannot have so many variations in the form. Box-shape, slab-shape, cylinder-shape are the most common shapes in high rise building. If more field study in high buildings with different forms can be carried, we can gain more data in this aspect.

More Precise Simulation to Validate the Research

The difficulty in simulating a high rise building is that both building-scale and room-scale are needed. Since the mesh number is unlimited, it is difficult to combine them together now.

More precise CFD simulation can help us to know the nature of the thermal comfort distribution. We will be able to quantitatively predict the comfort distribution, which makes the climate design handier.

References

- [1] Daniel Safarik and Antony Wood, "CTBUH Year in Review: Tall Trends of 2014, and Forecasts for 2015". 2014
- [2] Seppanen, O., and W. J. Fisk. "Relationship of SBS-symptoms and ventilation system type in office buildings." Lawrence Berkeley National Laboratory (2002).
- [3] Ken yeang. Bioclimatic Skyscrapers. P25. 1994
- [4] Antony Wood & Ruba Salib; Natural Ventilation in High-rise Office Building; 2013
- [5] Zhou, Chaobin, Zhiqiang Wang, Qingyan Chen, Yi Jiang, and Jingjing Pei. "Design optimization and field demonstration of natural ventilation for high-rise residential buildings." *Energy and Buildings* 82 (2014): 457-465.
- [6] Khan, Naghman, Yuehong Su, and Saffa B. Riffat. "A review on wind driven ventilation techniques." *Energy and Buildings* 40, no. 8 (2008): 1586-1604.
- [7] Dimitroulopoulou, C. "Ventilation in European dwellings: A review." *Building and Environment* 47 (2012): 109-125.
- [8] Xing, H., A. Hatton, and H. B. Awbi. "A study of the air quality in the breathing zone in a room with displacement ventilation." *Building and environment* 36, no. 7 (2001): 809-820.
- [9] Taleghani, Mohammad, Martin Tenpierik, Stanley Kurvers, and Andy van den Dobbelen. "A review into thermal comfort in buildings." *Renewable and Sustainable Energy Reviews* 26 (2013): 201-215.
- [10] Fanger, Poul O. "Thermal comfort. Analysis and applications in environmental engineering." *Thermal comfort. Analysis and applications in environmental engineering.* (1970).
- [11] AC. van der Linden; *Building Physics*; Chapter5;5-6;2008
- [12] de Dear, Richard J., and Gail S. Brager. "Thermal comfort in naturally ventilated buildings: revisions to ASHRAE Standard 55." *Energy and buildings* 34, no. 6 (2002): 549-561.
- [13] Fergus et al; *Adaptive thermal comfort*; 2012
- [14] van der Linden, Kees AC, Stanley SR Kurvers, Arjen AK Raue, and Atze AC Boerstra. "Indoor climate guidelines in The Netherlands: Developments towards adaptive thermal comfort." *Construction Innovation* 7, no. 1 (2007): 72-84.
- [15] NEN Standard EN15251. *Indoor environmental input parameters for design and assessment of energy performance of buildings- addressing indoor air quality, thermal environment, lighting and acoustics.* Comité Européen de Normalisation, Brussels (2007)
- [16] Nicol, Fergus. "Adaptive thermal comfort standards in the hot-humid tropics." *Energy and Buildings* 36, no. 7 (2004): 628-637.
- [17] ASHRAE Standard 55, *Thermal Environmental Conditions for Human Occupancy* ; 2004
- [18] Han, Jie, Wei Yang, Jin Zhou, Guoqiang Zhang, Quan Zhang, and Demetrios J. Moschandreas. "A comparative analysis of urban and rural residential thermal comfort

- under natural ventilation environment." *Energy and Buildings* 41, no. 2 (2009): 139-145.
- [19] Philomena M. Bluysen; *The Healthy Indoor Environment*; 2014
- [20] Yang, Liu, Haiyan Yan, and Joseph C. Lam. "Thermal comfort and building energy consumption implications—a review." *Applied Energy* 115 (2014): 164-173.
- [21] ISO 7730, 2005. Moderate thermal environments – determination of the PMV and PPD indices and specification of the conditions for thermal comfort. ISO, Geneva.
- [22] Koskela, H., J. Heikkinen, R. Niemelä, and T. Hautalampi. "Turbulence correction for thermal comfort calculation." *Building and Environment* 36, no. 2 (2001): 247-255.
- [23] Lin, Zhongping, and Shiming Deng. "A questionnaire survey on sleeping thermal environment and bedroom air conditioning in high-rise residences in Hong Kong." *Energy and Buildings* 38, no. 11 (2006): 1302-1307.
- [24] AS-NZS 1170-2 (2011) (English): Structural design actions - Part 2: Wind actions
- [25] Indraganti, Madhavi. "Thermal comfort in naturally ventilated apartments in summer: findings from a field study in Hyderabad, India." *Applied Energy* 87, no. 3 (2010): 866-883.
- [26] Griefahn, Barbara, Christa Künemund, and Ulrike Gehring. "The significance of air velocity and turbulence intensity for responses to horizontal drafts in a constant air temperature of 23° C." *International Journal of Industrial Ergonomics* 26, no. 6 (2000): 639-649.
- [27] Fanger, Povl Ole, Arsen Krikor Melikov, H. Hanzawa, and J. Ring. "Air turbulence and sensation of draught." *Energy and buildings* 12, no. 1 (1988): 21-39.
- [28] Wong, N. H., H. Feriadi, P. Y. Lim, K. W. Tham, C. Sekhar, and K. W. Cheong. "Thermal comfort evaluation of naturally ventilated public housing in Singapore." *Building and Environment* 37, no. 12 (2002): 1267-1277.
- [29] Dahlan, Nur Dalilah, Phillip John Jones, Donald Kneale Alexander, E. Salleh, and Dylan Dixon. "Field measurement and subjects' votes assessment on thermal comfort in high-rise hostels in Malaysia." *Indoor and Built Environment* 17, no. 4 (2008): 334-345.
- [30] Albert Klein Tank, Jules Beersma, Janette Bessembinder, Bart van den Hurk and Geert Lenderink; "KNMI' climate scenarios for the Netherlands 14" ;(2015).
- [31] Fung, Y. W., and W. L. Lee. "Identifying the most influential parameter affecting natural ventilation performance in high-rise high-density residential buildings." *Indoor and Built Environment* (2014): 1420326X14536189
- [32] Prajongsan, Pimolsiri, and Steve Sharples. "Enhancing natural ventilation, thermal comfort and energy savings in high-rise residential buildings in Bangkok through the use of ventilation shafts." *Building and Environment* 50 (2012): 104-113.
- [33] Tantasavasdi, Chalermwat, Jelena Srebric, and Qingyan Chen. "Natural ventilation design for houses in Thailand." *Energy and Buildings* 33, no. 8 (2001): 815-824.
- [34] Liping, Wang, and Wong Nyuk Hien. "Applying natural ventilation for thermal comfort in residential buildings in Singapore." *Architectural Science Review* 50, no. 3 (2007): 224-233.
- [35] Luo, Zhiwen, Jianing Zhao, Jun Gao, and Lixia He. "Estimating natural-ventilation potential considering both thermal comfort and IAQ issues." *Building and environment* 42, no. 6 (2007): 2289-2298.

- [36] Yang, Lina, Guoqiang Zhang, Yuguo Li, and Youming Chen. "Investigating potential of natural driving forces for ventilation in four major cities in China." *Building and Environment* 40, no. 6 (2005): 738-746.
- [37] Rijal, Hom B., Paul Tuohy, Michael A. Humphreys, J. Fergus Nicol, Aizaz Samuel, and J. Clarke. "Using results from field surveys to predict the effect of open windows on thermal comfort and energy use in buildings." *Energy and Buildings* 39, no. 7 (2007): 823-836.
- [38] Raja, Iftikhar A., J. Fergus Nicol, Kathryn J. McCartney, and Michael A. Humphreys. "Thermal comfort: use of controls in naturally ventilated buildings." *Energy and Buildings* 33, no. 3 (2001): 235-244.
- [39] Roetzel, Astrid, Aris Tsangrassoulis, Udo Dietrich, and Sabine Busching. "A review of occupant control on natural ventilation." *Renewable and Sustainable Energy Reviews* 14, no. 3 (2010): 1001-1013.
- [40] Fabi, Valentina, Rune Vinther Andersen, Stefano Corgnati, and Bjarne W. Olesen. "Occupants' window opening behaviour: A literature review of factors influencing occupant behaviour and models." *Building and Environment* 58 (2012): 188-198.
- [41] Haase, M., and A. Amato. "An investigation of the potential for natural ventilation and building orientation to achieve thermal comfort in warm and humid climates." *Solar Energy* 83, no. 3 (2009): 389-399.
- [42] Knaack, Ulrich, Tillmann Klein, Marcel Bilow, and Thomas Auer. *Façades: principles of construction*. Birkhäuser, 2014.
- [43] Barbosa, Sabrina, and Kenneth Ip. "Perspectives of double skin façades for naturally ventilated buildings: A review." *Renewable and Sustainable Energy Reviews* 40 (2014): 1019-1029.
- [44] Loonen, R. C. G. M., M. Trčka, Daniel Cóstola, and J. L. M. Hensen. "Climate adaptive building shells: State-of-the-art and future challenges." *Renewable and Sustainable Energy Reviews* 25 (2013): 483-493.
- [45] Gratia, Elisabeth, and André De Herde. "Is day natural ventilation still possible in office buildings with a double-skin façade?." *Building and Environment* 39, no. 4 (2004): 399-409.
- [46] Haase, M., and A. Amato. "An investigation of the potential for natural ventilation and building orientation to achieve thermal comfort in warm and humid climates." *Solar Energy* 83, no. 3 (2009): 389-399.
- [47] Lam, Joseph C., Liu Yang, and Jiaping Liu. "Development of passive design zones in China using bioclimatic approach." *Energy Conversion and management* 47.6 (2006): 746-762.
- [48] Philomena M. Bluyssen; *The Indoor Environment Handbook*; 2009
- [49] Herbert, GM Joselin, Selvaraj Niyan, E. Sreevalsan, and S. Rajapandian. "A review of wind energy technologies." *Renewable and sustainable energy Reviews* 11, no. 6 (2007): 1117-1145.
- [50] *Thermal design code for civil building (GB 50176-93)*. Beijing: China Planning Press; 1993 [in Chinese].
- [51] Philomena M. Bluyssen; *All you need to know about indoor air*; Delft Academic Press VSSD; 2015

- [52] Karjalainen, Sami. "Gender differences in thermal comfort and use of thermostats in everyday thermal environments." *Building and environment* 42, no. 4 (2007): 1594-1603.
- [53] Indraganti, Madhavi, and Kavita Daryani Rao. "Effect of age, gender, economic group and tenure on thermal comfort: a field study in residential buildings in hot and dry climate with seasonal variations." *Energy and buildings* 42, no. 3 (2010): 273-281.
- [54] NEN-EN 15251, Indoor environmental input parameters for design and assessment of energy performance of buildings addressing indoor air quality, thermal environment, lighting and acoustics, 2007
- [55] Indraganti, Madhavi. "Using the adaptive model of thermal comfort for obtaining indoor neutral temperature: findings from a field study in Hyderabad, India." *Building and environment* 45, no. 3 (2010): 519-536.
- [56] Lan, Li, Zhiwei Lian, Weiwei Liu, and Yuanmou Liu. "Investigation of gender difference in thermal comfort for Chinese people." *European Journal of Applied Physiology* 102, no. 4 (2008): 471-480.
- [57] Nikolopoulou, Marialena, and Spyros Lykoudis. "Thermal comfort in outdoor urban spaces: analysis across different European countries." *Building and Environment* 41, no. 11 (2006): 1455-1470.
- [58] Eliasson, Ingegärd, Brian Offerle, C. S. B. Grimmond, and Sven Lindqvist. "Wind fields and turbulence statistics in an urban street canyon." *Atmospheric Environment* 40, no. 1 (2006): 1-16.
- [59] ISO 7726, 2001. Ergonomics of the thermal environment - Instruments for measuring physical quantities. ISO, Geneva.
- [60] Ho, Son H., Luis Rosario, and Muhammad M. Rahman. "Thermal comfort enhancement by using a ceiling fan." *Applied Thermal Engineering* 29, no. 8 (2009): 1648-1656.
- [61] Hong, Taehoon, Jimin Kim, Juyoung Lee, Choongwan Koo, and Hyo Seon Park. "Assessment of seasonal energy efficiency strategies of a double skin façade in a monsoon climate region." *Energies* 6, no. 9 (2013): 4352-4376.
- [62] Thermische behaaglijkheid; ISSO-publicatie74
- [63] Knez, Igor, and Sofia Thorsson. "Influences of culture and environmental attitude on thermal, emotional and perceptual evaluations of a public square." *International journal of biometeorology* 50, no. 5 (2006): 258-268.

Appendix

A. Questionnaire

Questionnaire Indoor Climate in Roland Holstlaan

This questionnaire is part of my graduation thesis, which is about the thermal comfort and natural ventilation in high rise buildings. The research will help us to understand the indoor environment and provide further possibilities to improve the living condition in this and other similar buildings. The questionnaire is confidential.

Your participation will contribute to understanding indoor air quality and make it better. Thanks a lot for your help!

If you have any questions or you want to know further information of the project, feel free to contact me by the email below.

Kind regards,
Xiangyu Zheng
Graduate candidate in Building Engineering
X.Zheng-1@student.tudelft.nl

The questionnaire will take around 6 minutes.

1. PERSONAL INFORMATION

What is the date today? _____

How old are you? _____

What is your gender? Male Female Other

Where is your hometown?(City and country) _____

Where did you spend most of the time in the past four years? (City and country) _____

When did you come to Netherlands? _____

How long have you been living in this building? _____ months

How long will you live in this room in the future? _____ months

On which floor do you live? _____ floor

On which side of the building do you live? East West

2. LIFESTYLE

On a typical weekday, how many hours do you spend inside your home (including when you are sleeping)? _____hours

On a typical weekend, how many hours do you spend inside your home (including when you are sleeping)? _____hours

Do you go sports? Yes No

On average, how many days per week do you work-out (sports like gym, commuting by bike or foot, etc.)? _____days

With how many other persons do you share your apartment?

only myself 1 2 3 more_____

3. SYSTEMS AND ACTIVITIES

What is the type of heating system in your home?

Heater installed by DUWO Extra heater installed by your self

Is there a possibility to control the humidity (with a humidifier or integrated into the air conditioning system) in your home? Yes No

What kind of ventilation device is there in your room?

Operable Windows Mechanical extractor Fans Others:_____ (Please write it down)

Are you able to open the window(s) whenever you want? Yes No

If you are not able to open the window whenever you want to, how come? (Multi-choice)

You are not able to reach the window easily

It is not easy to position the window in an adequate position

Hindrance by draught

Hindrance by noise from outside

Anti-thief

Other reason(s): _____ (Please write it down)

Please specify the average frequency you have your window opened in a week.

- Every day
- Between 1-4 times a week
- Once per week or less

Please specify the average time you have your window opened in hours in one day.

_____hours

Usually, how do you set the ventilation system?

- Open the ventilation grill only
- Open the window from the side only
- Open the window from the top only
- Open the window from the top+ Open the ventilation grill
- Open the window from the side+ Open the ventilation grill

Please hatch the average period you shut the curtain(s) in a summer day by shadows.

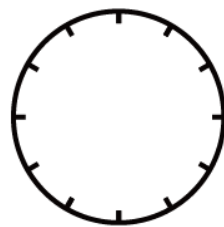

AM

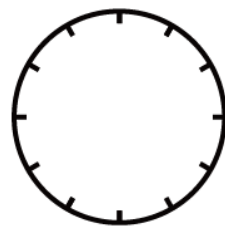

PM

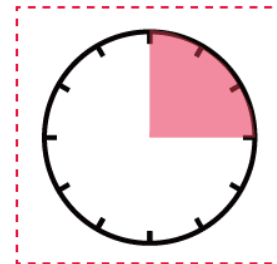

Example

4. HUMIDITY

Does condensation tend to form on windows?

- Yes, on the outside
- Yes, on the inside
- No

How do you dry your clothes?

- Hanging outside
- Hanging inside
- With a dryer

5. COMFORT

On a scale of 1 to 7, how would you describe typical living conditions in your house in general?

(If you have already experienced the season here)

Comfort Overall in summer

	1	2	3	4	5	6	7	
Unsatisfactory	<input type="checkbox"/>	<input type="checkbox"/>	<input type="checkbox"/>	<input type="checkbox"/>	<input type="checkbox"/>	<input type="checkbox"/>	<input type="checkbox"/>	Satisfactory

Temperature in summer

Too cold Too hot

Varies during the day Stable

Air movement in summer

Too draughty Too still

Air quality in summer

Humid Dry

Stuffy Fresh

Smelly Odorless

Noise from outside or other flat in summer

Unsatisfactory Satisfactory

Vibration in summer

Unsatisfactory Satisfactory

Comfort Overall in winter

	1	2	3	4	5	6	7	
Unsatisfactory	<input type="checkbox"/>	<input type="checkbox"/>	<input type="checkbox"/>	<input type="checkbox"/>	<input type="checkbox"/>	<input type="checkbox"/>	<input type="checkbox"/>	Satisfactory

Temperature in winter

Too cold Too hot

Varies during the day Stable

Air movement

Too draughty Too still

Air quality in winter

Humid Dry

Stuffy Fresh

Smelly Odorless

Noise from outside or other flat in winter

Unsatisfactory Satisfactory

Vibration in winter

winter

Unsatisfactory Satisfactory

How is your comfort today?

1 2 3 4 5 6 7
 Unsatisfactory Satisfactory

Temperature

Too cold Too hot

Varies during the day Stable

Air movement

Too draughty Too still

Do you often experience discomfort by cold at your lower legs, ankles or feet?

Always Often Sometimes Occasionally Never

Do you often experience discomfort by draught?

Always Often Sometimes Occasionally Never

Do you often experience discomfort by varying temperatures in different areas of the room?

Always Often Sometimes Occasionally Never

In summer, in how many days do you feel the indoor temperature is too high? _____ days

Less than 2 days 2-5 days 5-10 days More than 10 days

Do you get disturbed due to direct sun light when sun rising/setting? Yes No

Generally, what would be the main reasons for discomfort in your room? (Multi-choice)

- Too cold
- Too hot
- Temperature too variable
- Temperature not enough variable
- Air too humid
- Air too dry

- Air too stuffy
- Air too smelly
- Not enough light
- Too much light
- Too much glare from sun and sky
- Too much glare from artificial light
- Too much noise from outside the building
- Too much noise from building systems (e.g. heating, ventilation, air conditioning, plumbing etc.)
- Noise (other than from building systems)
- Too much vibration
- Other _____

6. REMARKS

Do you want to get further information about the research? If so, please provide your email address:

If you have any other complaints or recommendations concerning this research, please describe them below

Thanks a lot for your participation!

B. List of Figures

Figure 1: Workflow of the research	3
Figure 2: PPD as function of PMV	7
Figure 3: Adaptive thermal comfort [1]	9
Figure 4: Wind velocity and perceived temperature variation [15]	9
Figure 5: Class C- requirement for the operative indoor temperature, related to running mean out door temperature [62]	11
Figure 6: Local discomfort caused by vertical air temperature difference [21]	16
Figure 7: Local thermal discomfort caused by warm or cold floors [21]	16
Figure 8: Basic ventilation types	19
Figure 9: Wind gradient	21
Figure 10: Ventilation grill	23
Figure 11: Double façade system	24
Figure 12: Menara UMNO	25
Figure 13: Solar chimney	26
Figure 14: Perspective of Roland Holstlaan(1-749)	28
Figure 15: Roland Holstlaan(1-749) on a satellite map	29
Figure 16: The ventilation exhaust on the roof	29
Figure 17: Wall construction 1	30
Figure 18: Wall construction 2	30
Figure 19: The corridor on	30
Figure 20: The corridor on	30
Figure 21: The surroundings	30
Figure 22: Photo in one room in the building	31
Figure 23: A room 3D model	31
Figure 24: Koppen climate classification	32
Figure 25: Wind Rose Rotterdam, July	32
Figure 26: Wind Rose Rotterdam, August	32
Figure 27: Comfort zone in experimental period	34
Figure 28: The equipment used in the measurement	37
Figure 29: iButton	38
Figure 30: “Escort Juniors” Thermal&Humidity Data Logger	38

Figure 31: Hot Wire CFM Thermo-Anemometer	39
Figure 32: Experiment time period	41
Figure 33: The diagram for the distribution of the measured rooms'	43
Figure 34: Wind velocity measurement on the corridor	44
Figure 35: Measure points locations	45
Figure 36: Fixed ibutton	46
Figure 37: Fixed air velocity meter	46
Figure 38: Gender distribution of the residents	47
Figure 39: Age distribution of the residents	48
Figure 40: Nationality distribution of the residents	48
Figure 41: Diagram for the CFD model	49
Figure 42: Mesh of the CFD model	50
Figure 43: Closed window	52
Figure 44: Window open from the bottom	52
Figure 45: Simplification of the window	53
Figure 46: Window open from the side	53
Figure 47: Principle of the simplification	54
Figure 48: Residuals graph of the simulation	55
Figure 49: Main causes of discomfort	61
Figure 50: Whether the residents are able to open the window freely	62
Figure 51: Reasons that prevent the residents to open the window freely	62
Figure 52: Crime accounting map	63
Figure 53: The effect of privacy film	64
Figure 54: The influence of the visual privacy film	64
Figure 55: The temperature curve in the experimental period	66
Figure 56: Comfort zone with real temperature comparison	67
Figure 57: The operative temperature in two rooms on 12 th floor on the east side	68
Figure 58: The operative temperature in two rooms on 14 th floor on the east side	68
Figure 59: The operative temperature comparison on the different floors on the west side	69

Figure 60: The operative temperature comparison on the different floors on east side	70
Figure 61 : Residents' response to the temperature on the different floors	71
Figure 62: The operative temperature comparison of the close floors on different sides	72
Figure 63: The operative temperature comparison of the close floors on different sides	73
Figure 64: The humidity comparison in different rooms	74
Figure 65: Temperature comparison in one room	76
Figure 66: Comparison of the operative temperature and wall temperature	77
Figure 67: Temperature variation on 2 nd July	78
Figure 68: the temperature contours for case1- Horizontal	80
Figure 69: the temperature contours for case1- SectionA	80
Figure 70: the temperature contours for case1- Section C	81
Figure 71: the temperature contours for case2- Horizontal	82
Figure 72: the temperature contours for case2- Section A	82
Figure 73: the temperature contours for case2- Section C	83
Figure 74: the temperature contours for case3- Horizontal	84
Figure 75: the temperature contours for case3- Section A	84
Figure 76: the temperature contours for case3- Section C	85
Figure 77: Indoor air movement vote graph	87
Figure 78: the air velocity contours for case1- Horizontal	88
Figure 79: the air velocity contours for case1- Section A	88
Figure 80: the air velocity contours for case1-Section C	89
Figure 81: the air velocity contours for case2- Horizontal	90
Figure 82: the air velocity contours for case2- Section A	90
Figure 83: the air velocity Vectors for case2- Section A	91
Figure 84: the air velocity Vectors for case2- Section C	92
Figure 85: the air velocity contours for case3- horizontal	93
Figure 86: the air velocity contours for case3- Section A	94
Figure 87: the air velocity vector for case3- Section A	94
Figure 88: the air velocity contours for case3- Section C	95
Figure 89: The surrounding of the building	99

Figure 90: The solar radiation distribution in 1 st July	101
Figure 91: Temperature lines	102
Figure 92: The photo for the windows with and without films	105
Figure 93: Thermal comfort distribution in the researched building	106
Figure 94: The shading roof of Menara UMNO	107
Figure 95: Comparison of the thermal comfort before and after renovation	108
Figure 96: The principle of an external shading system	108
Figure 97: Velux window with adjustable shading system	110
Figure 98: H window	111
Figure 99: Room façade	112
Figure 100: Section A-A	112
Figure 101: Section B-B	113
Figure 102: Case 4-Temperature contours	114
Figure 103: Case 5- Temperature contours	115
Figure 104: Case4- Section A-temperature contours	135
Figure 105: Case4- Horizontal section-velocity contours	135
Figure 106: Case4- section A- velocity contours	136
Figure 107: Case5- section A- Temperature contours	136
Figure 108: Case 5- Horizontal section- Temperature contours	137
Figure 109: Case 5- section A- Temperature contours	137

C. List of Tables

Table 1: seven-point PMV thermal sensation scale	7
Table 2: Categories of the building types	10
Table 3: Mean outdoor temperature and corresponding Running mean temperature + Comfort limits	33
Table 4: Equipment list	37
Table 5: Boundary conditions of different cases	51
Table 6: Statistic results of general comfort classified by gender	57
Table 7: Statistic results of thermal comfort classified by gender	57
Table 8: Independent Samples Test of PMV in summer	57
Table 9: Independent Samples Test of PMV in winter	58
Table 10: Overall comfort distribution by nationality in summer	58
Table 11: Thermal comfort in summer	59
Table 12: Independent Sample Test of PMV between Indian and Chinese	59
Table 13: Independent Sample Test of PMV between Chinese and Greek	60
Table 14: Mean PMV of the residents for summer case	71
Table 15: Wind velocity distribution	73
Table 16: Sections showed in the CFD simulation	79
Table 17: Indoor air velocity in different rooms	86
Table 18: Indoor air movement vote statistical results by floor	87

D. Field Study Results

There are 96 questionnaires and measurement data for 15 days for the research. It is so large that it is not practical to include all of them in a word version. All the results are processed in SPSS. Therefore, the original SPSS file is attached in the CD.

E. Simulation results for recommendations

Case 4: H window- minimum open at night

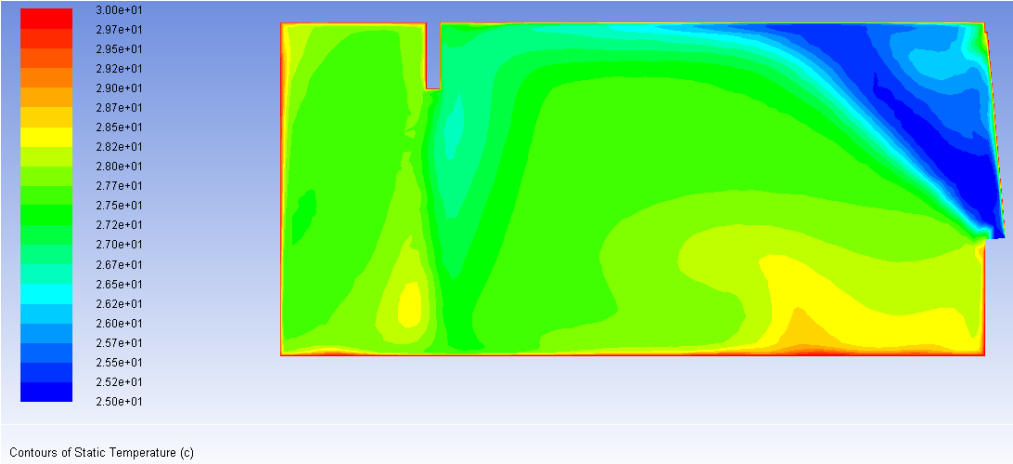

Figure 104: Case4- Section A-temperature contours

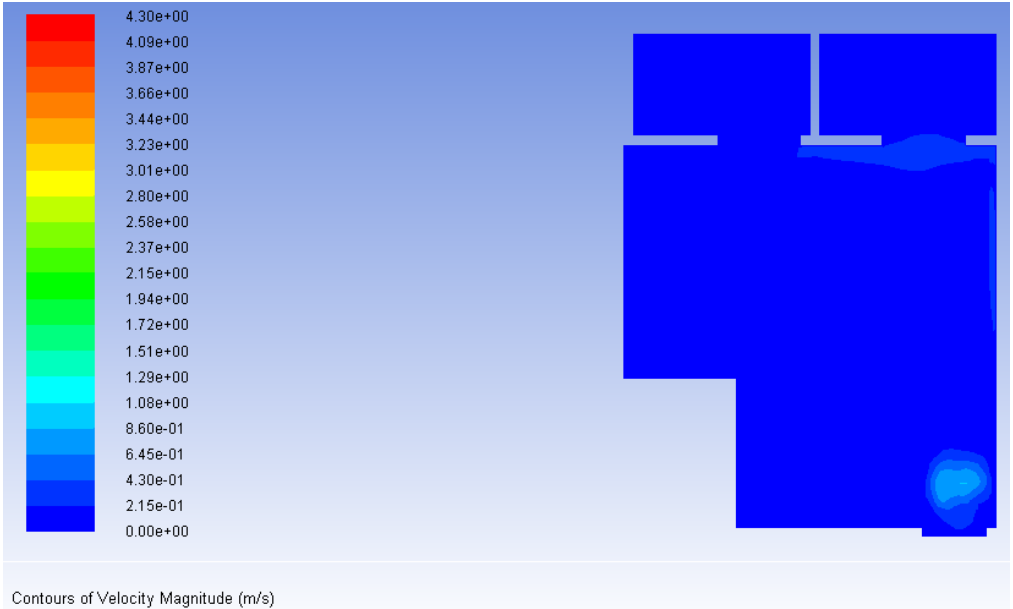

Figure 105: Case4- Horizontal section-velocity contours

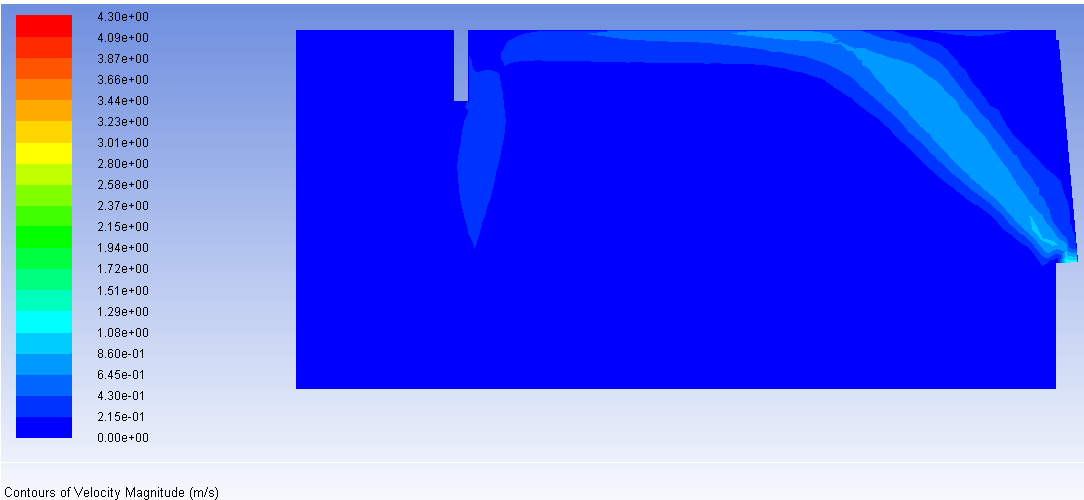

Figure 106: Case4- section A- velocity contours

Case 5: Only ventilator and grill open

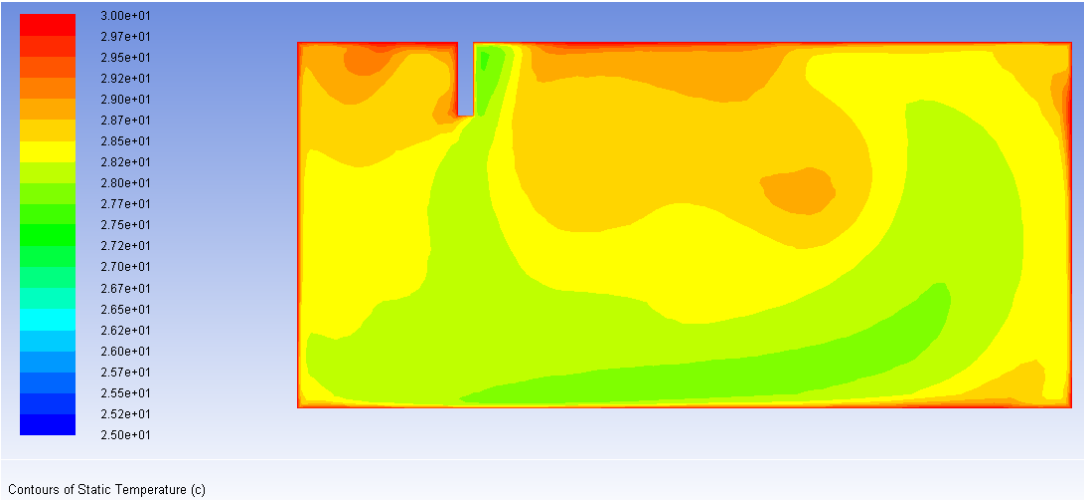

Figure 107: Case5- section A- Temperature contours

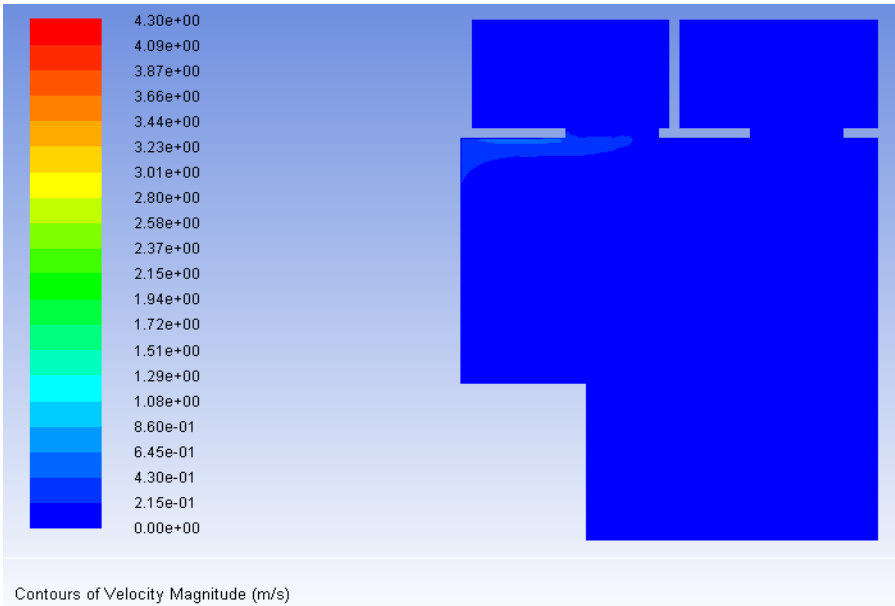

Figure 108: Case 5- Horizontal section- Temperature contours

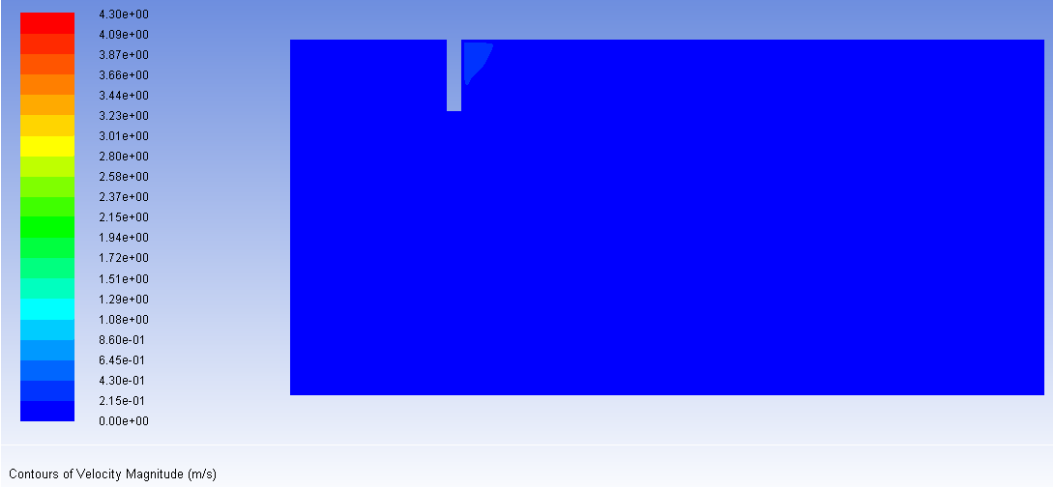

Figure 109: Case 5- section A- Temperature contours