

Advanced Partial Discharge Diagnostic of MV Power Cable System Using Oscillating Wave Test System

Key Words: Discharging faults, predictive maintenance, fault location, cable insulation, cable accessories

Medium-voltage cables are of key importance in the power distribution network. The enormous lengths of cable now installed, together with the socioeconomic costs of failure, have identified MV cable networks as a target for further attention.

Quality-assured components have been assembled together in a medium-voltage supply network which, if it fails, will cause repair costs, customer complaints, and loss of revenue or even associated claims. In fact, many sections of the network are frequently very mature, consisting of earlier types of components such as paper oil cables and bitumen joints. Mixtures of component types, ages, and workmanship standards result in a network whose reliability is difficult to predict. The modern trend is for asset managers in electrical utility companies to instigate predictive maintenance programs in an attempt to repair potentially faulty network components before problems occur. Of course, such a program must show a cost benefit.

The detection, location, and recognition of partial discharges (PD) at an early stage of possible insulation failure in medium voltage are of great importance for maintenance purposes. As a result, maintenance actions can be planned more precisely to prevent unexpected discontinuities in operation of the cable network (Fig. 1).

To obtain a sensitive picture of discharging faults in power cables the PD should be ignited, detected, and located at power frequencies that are comparable to operating conditions at 50 or 60 Hz. In this way, realistic magnitudes in [pC] and reproducible patterns of discharges in a power cable can be obtained. PD measurements during service as well as on-site continuous energizing at 50(60) Hz of MV cables are not always economically realistic for on-site inspections. Different energizing methods have been introduced and employed during recent years [1-4,6]. Therefore, based on the assumption that sensitive detection of critical PD sites occurs

**Edward Gulski, Frank J. Wester,
and Johan J. Smit**

Delft University of Technology

Paul N. Seitz

Seitz Instruments AG

Mark Turner

Heafely Test AG, Tettex Instruments Division

The enormous lengths of cable now installed, together with the socioeconomic costs of failure, have identified MV cable networks as a target for further attention.

by a method most similar to 50 Hz energizing conditions, a method as introduced in [4,6,7] for on-site PD diagnosis of MV cables will be discussed (Fig. 2).

Oscillating Wave Test System (OWTS)

Basic Theory of Oscillating Waves

With this method, the cable sample is charged with a DC power supply over a period of just a few seconds to the usual service voltage (Fig. 4). Then a specially designed solid state switch connects an air-core inductor to the cable sample in a closure time of $<1\mu\text{s}$ (Fig. 3). Now series of voltage-cycles start oscillating with the resonant frequency of the circuit:

$$f = 1 / (2\pi * \sqrt{L * C}) ,$$

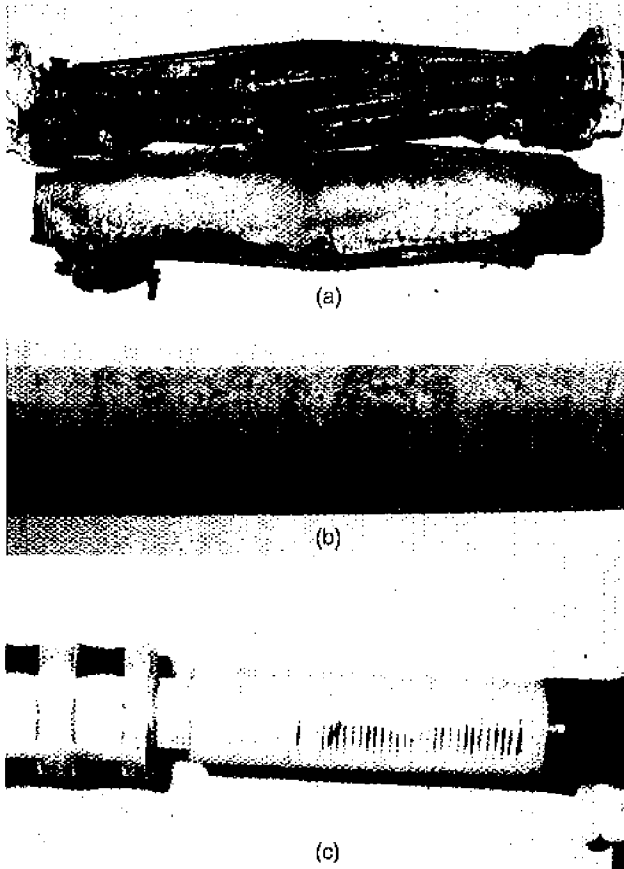

Fig. 1 Examples of defects, insulation degradation, and failures possible in a medium-voltage cable system:
 a) exploded oil-filled cable joint, due to water entering in the joint as three-phase short circuit occurred
 b) treeing in the insulation of a 45-year-old 50 kV mass-impregnated power cable
 c) mounting defect in a cable joint for plastic-insulated 10 kV cable: carbon tracks after not properly removed semicon

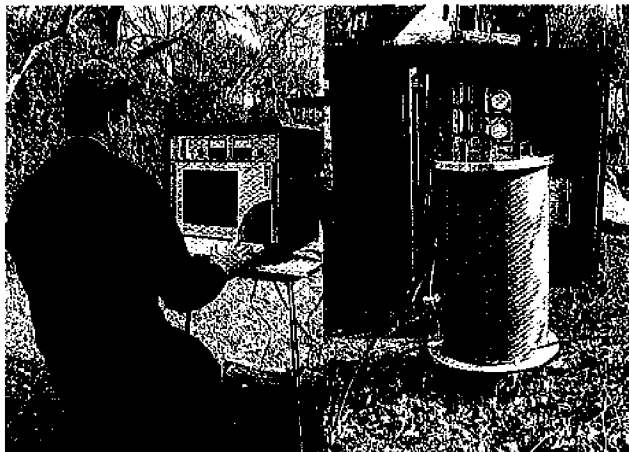

Fig. 2 Engineer performing cable measurements in the field

where L represents the fixed inductance of the air core and C represents the capacitance of the cable sample (Fig. 5).

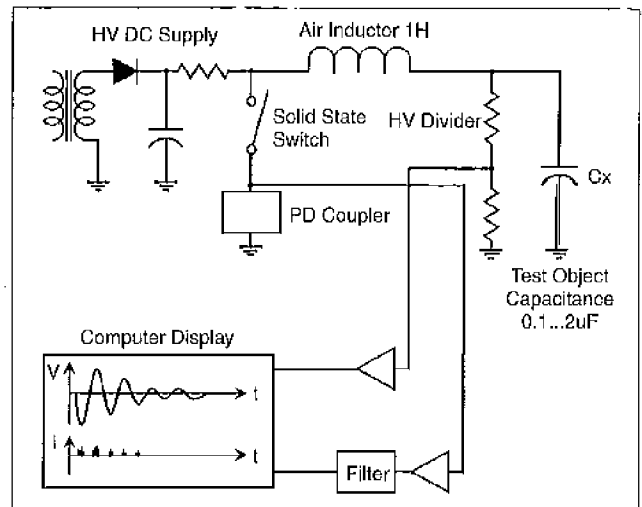

Fig. 3 Schematic diagram of the OWTS measuring circuit for on-site PD detection and location in power cables (<50 kV)

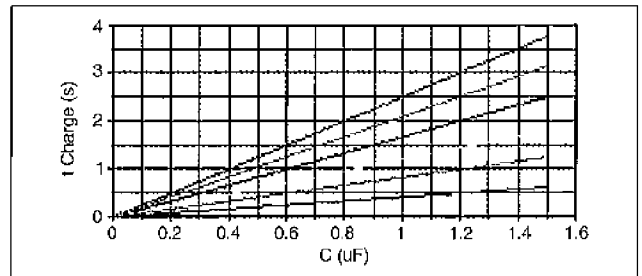

Fig. 4 Charging times needed to charge different cable samples capacitances to a specific voltage level in [kV] (top down: 30, 25, 20, 15, 10, 5)

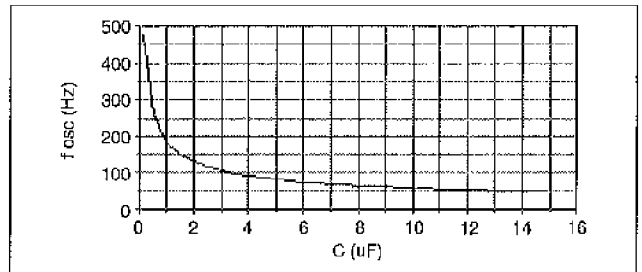

Fig. 5 Oscillating wave frequency as function of the cable capacitance

The air core inductor has a low loss factor and design, so that the resonant frequency lies close to the range of power frequency of the service voltage: 50Hz to 1 kHz. Due to the fact that the insulation of power cables usually has a relative low dissipation factor, the Q of the resonant circuit remains high depending upon cable: 30 to more than 100 (Fig. 6). As a result, a slowly decaying oscillating waveform (decay time 0.3 to 1 second) of test voltage is applied to energize the cable sample. During tens of power frequency cycles the PD signals are initiated in a way similar to 50 (60) Hz inception conditions. All of these PD pulses are measured using a fast digitizer.

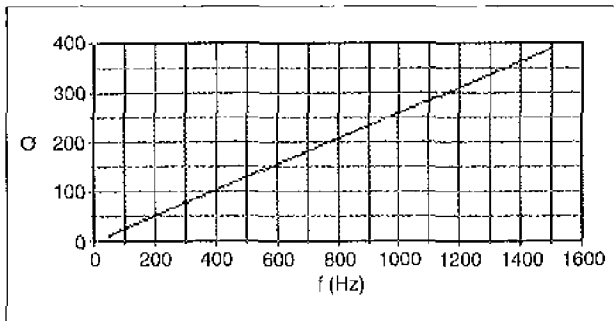

Fig. 6 Q of the resonance circuit as function of the oscillating wave frequency

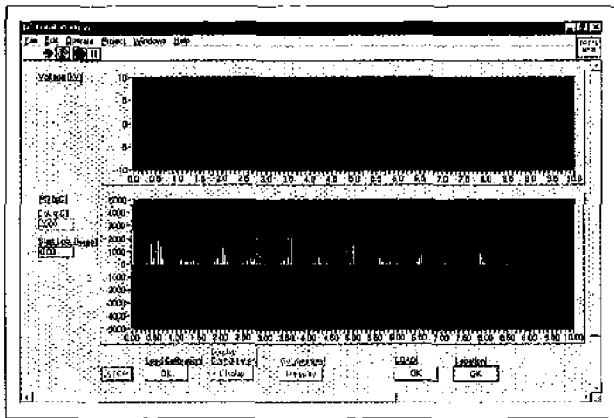

Fig. 7 Example of PD pulses as measured during 12 kV oscillating wave on a 10 kV XLPE power cable, having internal discharges

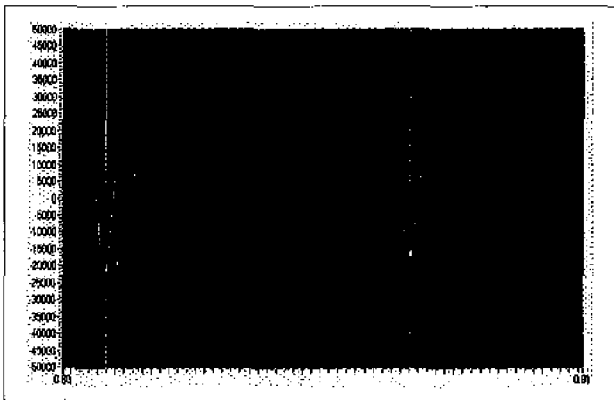

Fig. 8 Example of PD site location after 9 kV oscillating wave charging of a 10 kV paper-oil power cable

PD Detection

The advantage of a high Q circuit is that PD can be measured on-site for a series of undisturbed sinusoidal cycles of the test voltage. For this purpose a special PD detection circuit has been used providing sensitive detection of discharge signals. Due to the fact that the switched DC power supply produces disturbances during charging of the cable sample, the PD circuit is therefore inhibited during this time. During

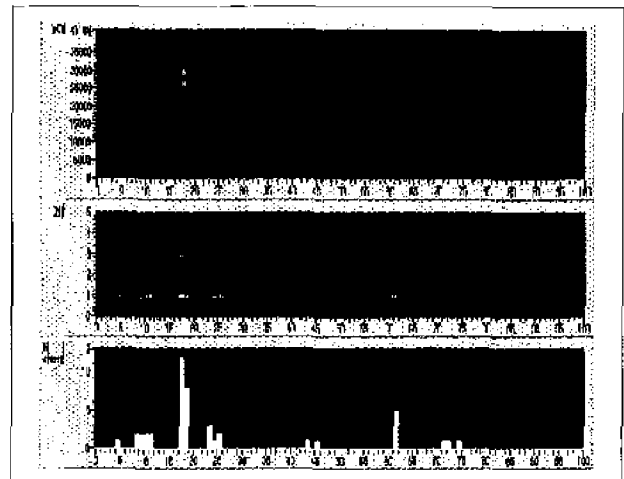

Fig. 9 Example of statistical evaluation obtained after oscillating waves applied to a 840m long 10 kV paper-oil power cable; top = PD magnitudes versus location in the cable; middle = PD intensity versus location in the cable; bottom = PD intensity (5m classes) versus location in the cable

the oscillating phase of the test cycle the DC power supply is disconnected to provide sensitive PD measurement (Fig. 7).

Since the oscillating frequency represents the AC conditions of the power line frequency, the measurement bandwidth of the PD circuit has been chosen in accordance with IEC 60270 recommendations. For the purpose of location by travelling waves, the bandwidth is increased up to 10 MHz (Fig. 8). In combination with a 100 MHz digitizer and depending upon cable type—e.g., XLPE or paper-oil—the detection and location of PD pulses remains sensitive for cable length of few kilometers.

PD Evaluation

The PD signals, which are ignited during one or more oscillating waves and are detected by the system, can be processed for two purposes.

First, each of the PD pulses can be analyzed for reflections using travelling wave analysis (Fig. 9). Statistical evaluation of PD signals obtained after several oscillating waves can be used to evaluate the location of discharge sites in the power cable (Fig. 9).

Second, values of capacitance C and $\tan \delta$ can be calculated based upon the oscillating wave time and frequency characteristics (Fig. 10).

Third, after several oscillating waves the whole discharge sequence can be resolved into a phase-resolved PD pattern. In this way patterns can be obtained that are similar to those recognized under 50 (60) Hz conditions (Fig. 11).

For recognition purposes such PD phase-resolved patterns can additionally be processed using statistical discrimination and classification tools [8,9]. As a result, PD databases with reference to typical degradation examples in cables or cable accessories can be created for maintenance purposes [10].

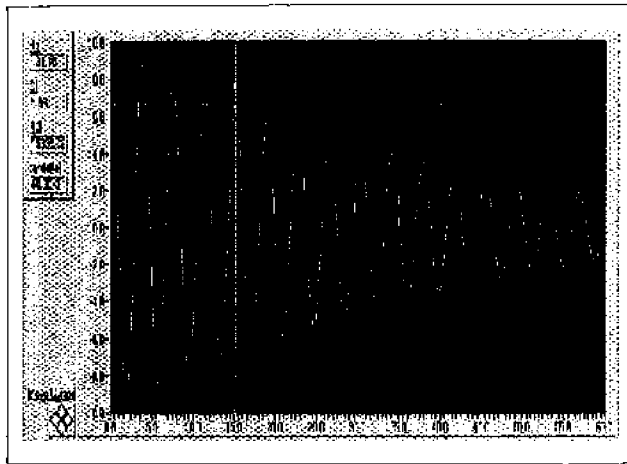

Fig. 10 Example of calculation of C and $\tan \delta$ on the basis of oscillating wave time

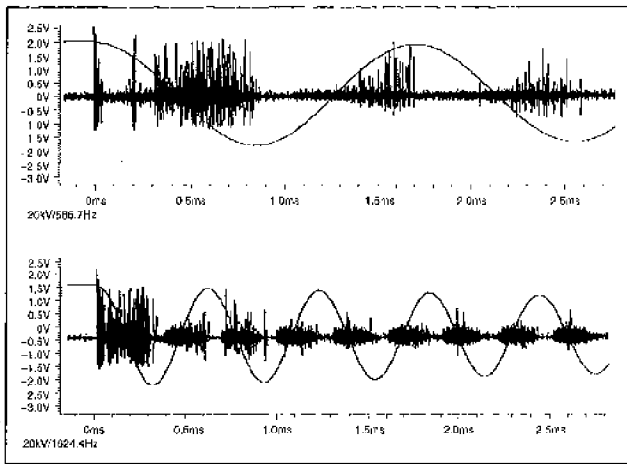

Fig. 11 Comparison of phase-resolved PD patterns obtained by OWTS for the same internal defects for two different wave frequencies

Comparison to 50 Hz AC Energizing Method

Evaluating insulation condition of a cable section on the basis of the PD activity, several aspects are of importance [11, 12]. Among others, the evaluation of PD inception voltages as well as the measurable PD amplitudes and finally the phase-resolved PD patterns are important by analysis of discharging site in a cable section.

To prove that PD phenomena (inception condition, PD level) as observed at oscillating wave voltage stress are truly representative of a 50/60 Hz wave applied voltage, several on-site tests have been performed in the past, where the cable samples are stressed with 50 Hz ac voltages and oscillating wave voltages. In the following important results of these investigations are presented.

PD Inception Voltage and PD Magnitude

Laboratory experiments have been performed to provide insight into the inception conditions and measurable PD amplitude [7]. A series of PD measurements were performed on

Defect	ac 50 Hz		OWTS 1066 Hz	
	U_{inc} [kV]	PD [pC]	U_{inc} [kV]	PD [pC]
Bad Contact between Semicon and the Stress Cone	2.6	25	3	30
Bad Adjustment of the Stress Cone	15	20	13	40
Internal Cavities	13	150	14	70

Fig. 12 Comparison of PD magnitudes and inception voltages obtained for the same internal defects in cable accessories by different charging voltages: 50 Hz (ac) power frequency and oscillating wave voltages of 1066 Hz

Test Voltage		ac 50 Hz	OWTS 220 Hz
		12 kV (A) (B) (C)	450 pC 370 pC 500 pC
16 kV (A) (B) (C)	850 pC 700 pC 770 pC	950 pC 850 pC 900 pC	

Fig. 13 Comparison of PD magnitudes measured using 50 Hz (ac) power frequency, and oscillating wave voltages of 220 Hz applied on three 323.5 m long 50 kV mass power cables: (A), (B), and (C) at 12 kV and 16 kV two voltage levels

realistic internal defects made in 6 kV plastic insulated cable accessories. In particular, the same samples have been energized with initially 50 Hz and then again using 1066 Hz oscillating wave voltages. In Fig. 12, results of inception voltages and measurable in [pC]/[nC] PD levels are summarized.

In Fig. 13, a comparison of PD magnitudes measured at two voltage levels on three cable samples is shown. Using both methods, the inception of discharges was detected at the following voltages: sample (A): 6 kV; sample (B): 3 kV; sample (C): 5 kV.

It follows from these figures that in comparison with 50 Hz (ac) the PD level as well as the PD inception voltages are in the same range. As a result, taking into account the stochastic behavior of internal discharges no significant difference has been observed.

PD Location Mapping

It is known that a local presence of discharges in a cable section or in cable accessories indicates possible defect, e.g., mounting defect, local insulation degradation. Therefore, in

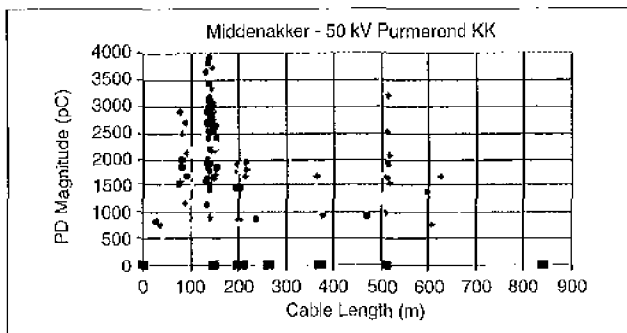

Fig. 14 PD location mapping made on the basis of PD measurements using oscillating wave charging (2.5 times) of a 840 m long, 17-year-old 10 kV paper/oil power cable

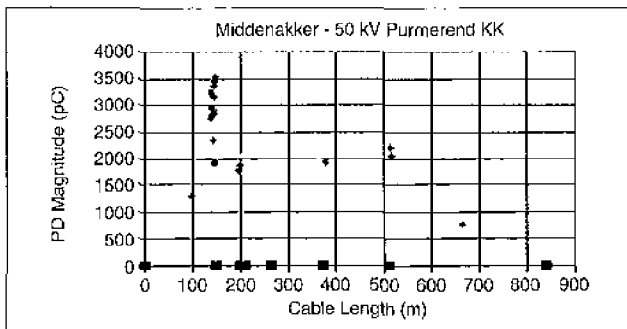

Fig. 15 PD location mapping made on the basis of PD measurements using 50 Hz ac energizing (15 minutes) of a 840 m long, 17-year-old 10 kV paper/oil power cable

	Voltage [kV]	Measured PD [pC]		
		Cable a	Cable b	Cable c
Phase U	0.3 U_0	-	-	1500
	0.5 U_0	1400	2500	3500
	U_0	2900	2900	4000
Phase V	0.3 U_0	-	-	1500
	0.5 U_0	1400	2500	3500
	U_0	3000	3000	4500
Phase W	0.3 U_0	-	-	1700
	0.5 U_0	1600	2500	3300
	U_0	2900	3000	4100

the case that the PD inception voltage, the detectable PD magnitudes as well as phase-resolved PD patterns can be a symptom for deviation of insulation conditions of a particular cable section, sensitive location of discharging sites is important. For this purpose as mentioned in the previous text, several PD pulses are analyzed as travelling waves for their reflections. As a result a PD location mapping can be made, showing the PD amplitudes or intensity in function of the cable length and the location of cable accessories (Figs. 14 and 15).

In Figs. 14 and 15, PD location mappings are shown, which have been obtained using both methods applied to the

same 840 m-long 10 kV cable section. It follows from these figures that, using both methods, the same discharge sites are ignited producing similar PD magnitudes. In particular, both the ac 50 Hz energizing as well as the oscillating wave charging indicates in the joint located at 150 m PD discharge activity of 4000 pC, which is much higher than elsewhere in the cable section.

Unless in this particular joint a deviating PD behavior has been found, to judge the seriousness of the source of these discharges for the insulation condition of this particular cable, further investigation of discharging defects in these type of accessories is necessary.

Field Experiences

Based on three examples from field measurements several relevant aspects related to PD diagnostics of medium-voltage power cables are discussed here [12,13].

Different Insulation Conditions

Measurements discussed in this example are performed on three 10 kV paper/oil power cable sections:

- 3-core 240 mm² Al cable section of 840 m, dating from 1982;
- 3-core 95 mm² Cu cable section of 775 m, dating from 1963;
- 3-core 240 mm² Al cable section of 4823 m, dating from 1993.

The PD measurement results from the three cable sections are reflected in Table I. This comparison of PD inception conditions and PD amplitudes shows that in each of the cable sections different processes occur:

- unless at U_0 cables a and b show the same PD magnitudes, at $\frac{1}{2} U_0$ cable b shows much higher PD than cable a;
- cable c shows in comparison to cables a and b at all voltages much higher PD magnitudes.

This small comparison may indicate that unless negligible differences in PD magnitudes as observed at U_0 various degradation processes are going on in all the three cable sections. Figure 16 shows the PD mappings as made for all three cables investigated. The mappings are obtained from several PD measurements at oscillating voltages up to 2 U_0 .

According to [14], the use of higher frequencies at 2* U_0 should not influence the destructiveness of the test procedure than at 50/60 Hz ac energizing method. On the contrary, it has been shown in [14,15] that the breakdown at oscillating voltages are up to two times higher compared to 50/60Hz.

The upper evaluation clearly shows PD activity on different joints (black squares) of a cable section. For example, there is a concentration of PD at the cable joint of 150 m from the measuring place, with amplitudes up to 4000 pC in all three phases. The cable joint at 500 m shows a PD concentration with PD amplitudes up to 3500 pC, but mainly in the red phases.

The second evaluation shows that PD concentrations can also occur on a location between two joints, in the paper/oil

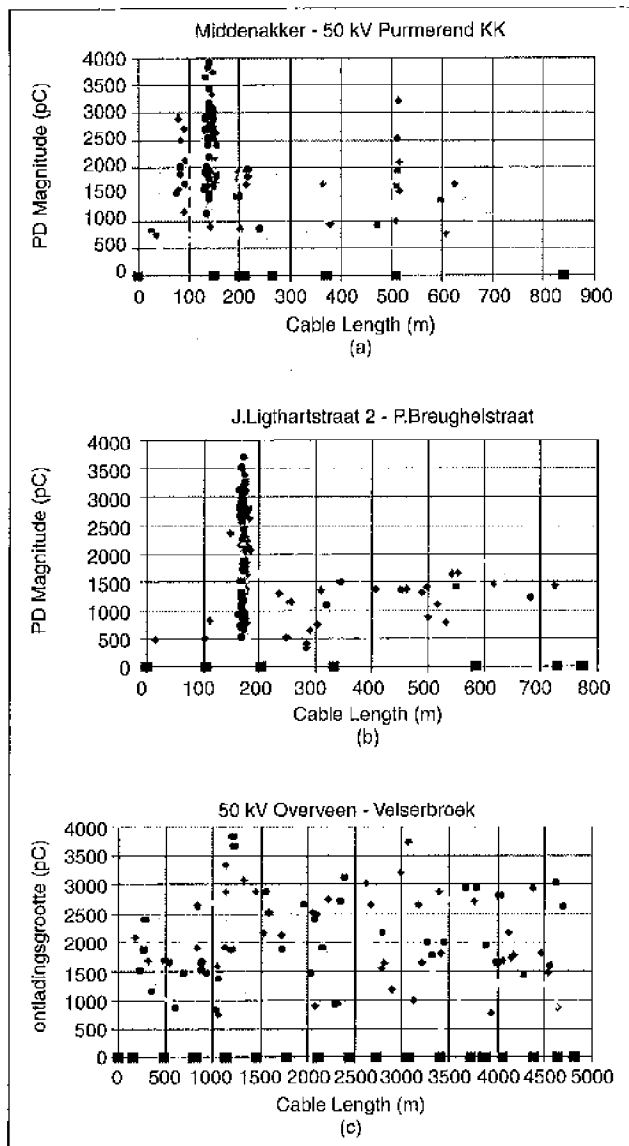

Fig. 16 PD mapping from measurements on three 10 kV paper oil power cables (black squares are the locations of the cable joints):
 a) PD concentration located on the cable joints
 b) PD concentration in cable insulation
 c) no clear PD concentration

cable insulation. In this case, a clear concentration of PD is located at 175 m from the measuring place, between the cable joints at 105 and 200 m. The network documentation reveals that at this location, the cable runs through a pipeline under a motorway.

The third PD mapping of Fig. 16 shows that a clear concentration of PD in the cable section is not always the case. A number of PD pulses is measured in the three phases, but they all come from different locations in the cable section.

It follows from the comparison that degradation process of a joint or local damage of cable insulation or even the insulation degradation of the whole cable section shows at U_0 comparable PD magnitudes. The combination of these val-

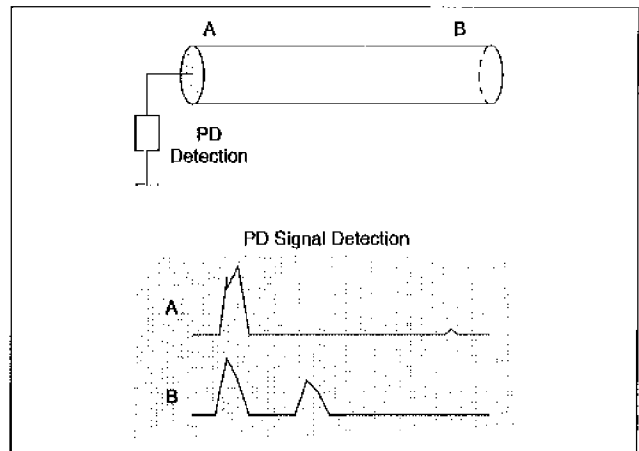

Fig. 17 Due to the attenuation of PD signals, PD pulses from the opposite than the remote side are better detectable as the pulses on the remote side in long length power cable sections. PD located at A give very small reflections, in contrast to PD located at B

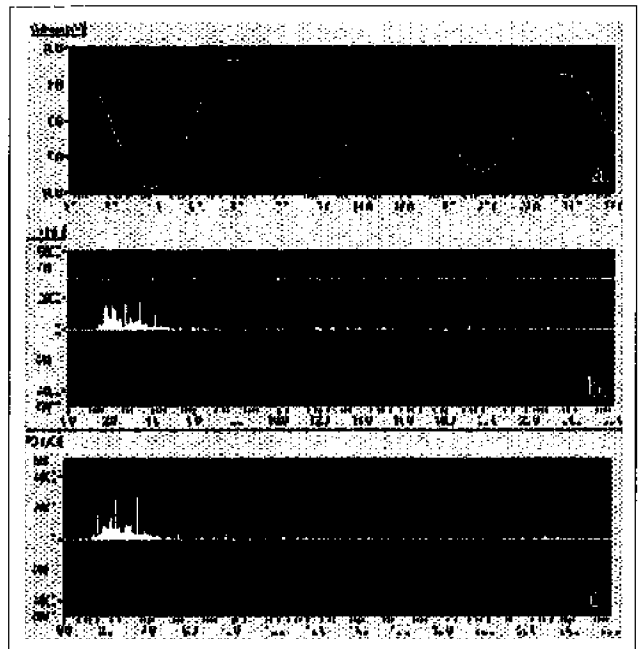

Fig. 18 Result from measurements on a 4823 m long 10 kV paper/oil power cable:
 a) test voltage of 120 Hz
 b) PD signals measured on 50 kV Overveen side
 c) PD pattern measured on Velsbroek side

ues with the PD inception conditions and determination of discharge sites provides additional information for condition evaluation.

Nevertheless, at this moment no statements can be made about the criticality of these defects, but it is known that PD concentrations are more harmful than discharges in the whole length of the cable without concentrations. To obtain this information more systematic on-site tests are necessary on similar cables as well as laboratory investigation on service aged cable samples and accessories.

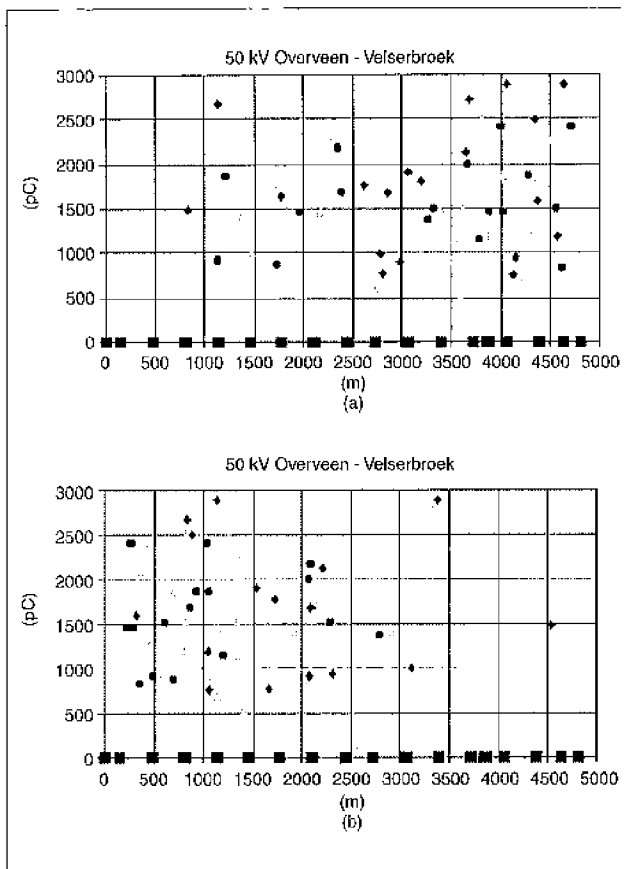

Fig. 19 PD mappings obtained from measurement on the both sides of a 4823 m long 10 kV power cable sections. PD in the opposite half from the measuring side could be detected. Mapping a) was obtained from measurements on side A and mapping b) from measurements on side B

U_{top}	phase U	phase V	phase W
5 kV	150 pC	200 pC	150 pC
12 kV	380 pC	400 pC	400 pC
22 kV	800 pC	800 pC	850 pC

PD Pattern Analysis for Long-Length Cables

It is known that due to attenuation of PD signals, the detection and location of discharges in long-length cables (> 4km) is difficult. In particular, pulses coming from the opposite of the remote end are better detectable than those coming from the remote side (see Fig. 17).

To discuss this problem, measurements are performed on a 3-core 240 mm² Al cable section dating from 1993. Total length of this paper/oil cable section is 4823 m. Measurements on this cable section are performed on both sides. Figure 18 shows the measurement results from the two sides of the cable section (b and c) at a test voltage of 9 kV_{top} (a). Inception voltage, PD levels, and PD patterns are similar for both measuring sides.

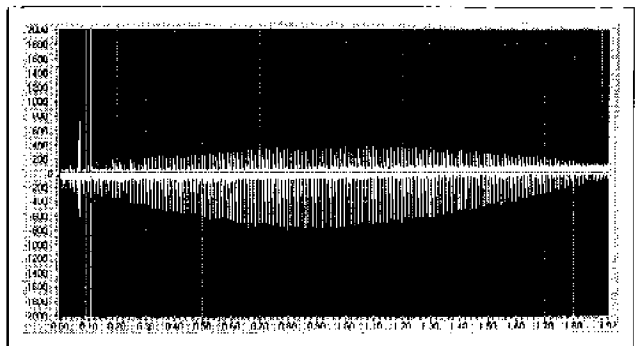

Fig. 20 Sine resembling PD pattern in the negative half of the power frequency cycle, measured on five 50 kV paper/oil power cables; location of the PD pulses was not possible

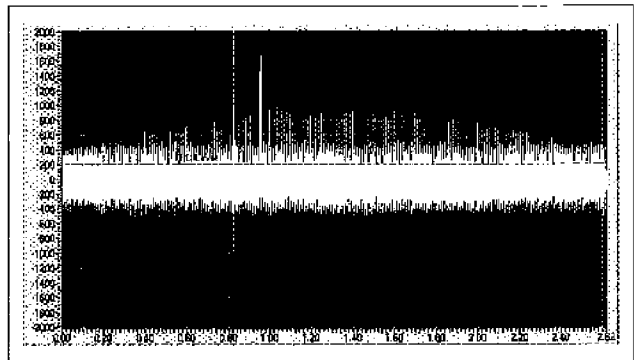

Fig. 21 Sine resembling PD pattern in the positive half of the power frequency cycle with high peaks, measured on a 2080 m long 50 kV power cable. The location of the high PD signals can be determined

Location of the detected PD signals can be made for those pulses originating from PD sources on the opposite half of the cable section from the measuring side. Figure 19 a shows the mapping of located PD from the 50 kV Overveen side, the mapping from the Velsbroek side is reflected in Fig. 19 b.

As shown in this example, a combination of PD measurements on both sides, combined with PD inception voltage, PD magnitudes, and patterns can support PD diagnostics of long-length power cables.

Location of Discharge Sites in Combination with PD Patterns

This example handles the measurements performed on six 1-core 120 mm² 50 kV mass power cable, three with a length of 3235 m, the other three with a length of 2080 m. The measuring results from OWTS of one of the cables is reflected in Table II (other cables show same results). The cable was measured with OWTS up to 22 kV_{top}. The table shows a slight growth of PD amplitude as voltages increase.

A notable fact from the performed measurement is that with five of the six cables, no particular location of the measured PD activities, as shown in examples 1 and 2, could be determined. Figure 20 shows the measured PD patterns with OWTS from these power cables. The PD shows a sine-resembling pattern.

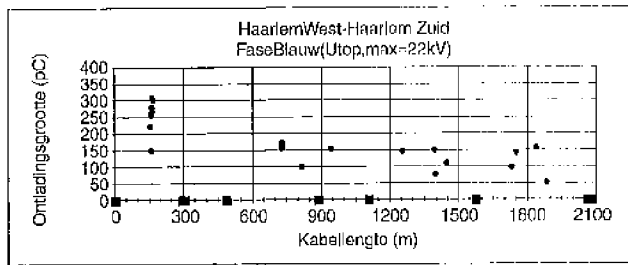

Fig. 22 PD mapping of high amplitudes PD signals as shown in Fig. 23

Based on this fact and that PD magnitudes are in the low range the PD activity originates from the total length of the cable, caused by degradation of the insulation material during the 45 years of exploitation.

In one of the six measured cables, it was possible to locate the discharges. Figure 21 shows the measured PD pattern from this power cable. Here, the sine-resembling pattern is visible too, but also high PD signals are towering above the pattern. From these high PD peaks, the location can be determined. An overview of the located PD is shown in Fig. 22. A concentration of PD is located at 15.5 m from the measuring side.

Summary

- Stressing cables with oscillating waves provides ignition conditions for partial discharges that are similar to 50 Hz AC energizing conditions. In this way the PD inception voltage, PD magnitudes as well as the phase-resolved PD patterns are representative for discharging defects. Moreover, based on the traveling wave principle particular discharge sites can be traced back. As a result, it can be concluded that OWTS is a practical and convenient solution for on-site PD diagnosis of medium-voltage power cables.
- With regard to using OWTS as diagnostic tools for after-laying tests or maintenance purposes of MV cable networks, several aspects are of importance. Discharges detected in a cable section can be related to different insulation conditions:
 - discharging in a particular cable accessory;
 - discharge sites in the cable insulation;
 - discharging of the cables insulation without particular discharge site.
- The detection of discharges in a cable is not sufficient to judge the seriousness of the discharge source for the insulation condition of a particular cable or an accessory. For this purpose detailed investigation of discharging defects in a type of insulation is necessary:
- analysis of PD inception conditions, PD magnitudes and phase-resolved PD patterns;
- ageing and degradation effects in the insulation and their manifesting by partial discharges.
- Verifying these results on systematic feedback from on-site tests, the OWTS method as a compact and nondestructive tool can become an indispensable tool for diagnosis support- and condition-based maintenance of medium-voltage power cable systems.

Further Research

The goal for electricity utilities is to obtain a sensitive determination of the insulation condition of the medium-voltage power cable network. To build up a cable diagnostic, a systematic approach is necessary. Therefore, high-risk cable sections in the network should be identified and PD measurements on these cable sections performed. In particular three steps should be taken to develop a condition based diagnostics:

1. From the measurements, systematic information should be obtained on typical PD behaviors for different cable sections. This information contains the inception conditions of the PD (inception voltage, PD magnitude, cable temperature), the phase resolved patterns of the measured PD signals, and furthermore the location of the PD in the cable system (cable insulation, cable joints, or cable terminations).
2. Evaluation of important degradation processes in service of power cables should be made by identification of relevant parameters to indicate the condition of the cable. By developing a database, evaluations of the systematic measurements are simplified.
3. Finally, the implementation of diagnostics and knowledge rules for different insulation materials (cable insulation, accessories) should be made and the application in the field checked.



Edward Gulski was born in 1958 in Poland. In 1982 he received his Masters degree in Information Technology from the Dresden University of Technology in Germany, and from 1982 through 1986 he was a research assistant in the HV laboratory there.

In 1987 he began research in the partial discharge diagnostics field, relocating to the Netherlands' Delft University HV Laboratory. In 1991 he received his Ph.D. degree from Delft University of Technology. At present, he is an associate professor involved in education and research in the field of insulation diagnosis of HV components. He is a member of different CIGRE working groups and task forces.



Frank J. Wester was born in 1972 in the Netherlands. In 1998 he received his M.S. in electrical engineering at Delft University of Technology in the field of advanced on-line diagnostics on GIS. Since 1998 he was employed at NUON ENW in Amsterdam, the Netherlands, as a diagnostic engineer. He is also working toward a Ph.D. in the field of on-site diagnostics for condition-based maintenance of medium-voltage power cable networks at the HV Laboratory at the Delft University of Technology.



Johan J. Smit was born in 1949 in the Netherlands. In 1974 he received his Master's thesis degree in experimental physics at the University of Amsterdam, and in 1979 he received his Ph.D. at the State University of Leiden for his research in magnetism on behalf of the National Science Foundation. He was employed for 17 years at KEMA in Arnhem, where he became section manager within the transmission and distribution com-

pany. Since 1996 he has been a professor in high-voltage technology at the Delft University of Technology. Currently his specific areas of interest are dc and ac HV materials, advanced diagnostics, and maintenance support systems. He is a member of the Technical Committee of IEC '98 on Electrical Insulation Systems. In 1993 he became secretary of Cigre Study committee 14, Materials for Technology, of which he is now chairman.



Paul N. Seitz was born in 1940 in Switzerland. In 1964 he received his B.S. in electrical engineering from the HTL of Zurich. From 1965 through 1972 he worked in the U.S. semiconductor industry, at Transiron and Fairchild, designing integrated circuit test systems.

In 1972 he co-founded, with other engineers, Quantor Corp. and worked as senior design engineer for microfilm recorders. In 1974 he was hired as chief engineer at Tettex Instruments, designing partial discharge and tan delta test equipment. In 1983 he joined HAEFELY in Basel and headed the electronic department in charge of the design of partial discharge, impulse, and tan delta test systems. In 1993 he started his own company, SEITZ Instruments AG, and presently designs and manufactures instruments for the high-voltage field.



Mark Turner was born in 1962 in England. He received his training as an electronics engineer and avionics technician with the Royal Air Force and then changed to a sales career in test instrumentation, attaining his first management position in 1988. Areas of focus from 1985 to 1990 included TV and radio test equipment, oscilloscopes, power supplies, and logic analyzers. 1990 to 1996 was spent in a variety of different sales and marketing roles with Robinson Instruments, a UK manufacturer of partial discharge detectors, military chart recorders, and naval switchgear. In 1996 he left the UK to join the Tettex Division of Haeefely Test AG and is currently studying for an executive MBA at St. Gallen in Switzerland.

References

1. *Partial Discharge Measurements*, IEC 60270, Third edition, 1998-06.

Coaxial 30kV Connectors

(continued from page 11)



Gerhard H. Schröder has studied telecommunications and holds a Ph.D. in high-voltage engineering and gas discharge physics. He is head of a team that has built a large part of CERN's fast pulsed magnet systems and is now in charge of the construction of the kicker magnet systems of the Large Hadron Collider.

References

1. P.E. Faugeras, E. Frick, C.G. Harrison, H. Kuhn, V. Rödel, G.H. Schröder, and J.P. Zanasco, The SPS Fast Pulsed Magnet System, Paper presented at the 12th Modular Symposium, New York, 1976.

2. E. Pultrum and E. Hetzel, *VLF Discharge Detection as a Diagnostic Tool for MV Cables*, IEEE PES 1997 Summer Meeting, 20-24 July 1997, Berlin.
3. E. Lemke, P. Schmiegel, H. Elze, and D. Russwurm, *Procedure for Evaluation of Dielectric Properties Based on Complex Discharge Analysing*, IEEE International Symposium on EI, Montreal, Canada, 16-19 June, 1996.
4. R. Parth, W. Kalkner, and I. Krage, *Vergleich von Diagnosesystemen zur Beurteilung des Alterungszustandes PE/VPV-isolierter Mittelspannungskabel*, Elektrizitätswirtschaft, Jg. 96 (1997).
5. J.T. Holbøll and H. Edin, *PD-Detection vs. Loss Measurements at High Voltages with Variable Frequencies*, 10th Int. Symposium on HV Engineering, Montreal, Canada, 1997.
6. E. Galski, J.J. Smit, P.N. Seitz, R.E.F. Koning, and M. Turner, *On-site PD diagnostics of medium-voltage power cables*, Jicable'99, Paris, 20-24 June 1999.
7. E. Galski, J.J. Smit, P.N. Seitz, and J.C. Smit, *PD Measurements On-site using Oscillating Wave Test System*, IEEE International Symposium on EI, Washington DC, USA, 7-10 June 1998.
8. E. Galski and P. Seitz, *Computer-aided registration and analysis of PD in HV equipment*, 8th ISH, Yokohama, Japan, 1993.
9. E. Galski, H.P. Burger, A. Ziclonka, R. Brooks, *Classification of Defects in HV Components by Fractal Analysis*, CEIDP, San Francisco, 1996.
10. E. Galski, J.J. Smit, and R. Brooks, *PD Databases for Diagnosis support of HV Components*, 1998 IEEE International Symposium on EI, Washington.
11. E. Galski, J.J. Smit, P.N. Seitz, J.C. Smit, and M. Turner, *On-site PD diagnostics of power cables using oscillating wave test system*, ISH'99, London, 23-27 August 1999.
12. F.J. Wester, E. Galski, J.J. Smit, and P.N. Seitz, *Experiences from on-site PD measurements using oscillating wave test system*, ISH'99, London, 23-27 August 1999.
13. F.J. Wester, E. Galski, and J.J. Smit, *Electrical and acoustical PD on-site diagnostics of service aged medium voltage power cables*, Jicable'99, Paris, 20-24 June 1999.
14. E. Gockenbach, *Breakdown behaviour of polymer insulating material at different frequencies*, Haeefely HV Testing & Diagnostics Seminar '99, San Antonio, 9-10 June 1999.
15. R. Bach and W. Kalkner, *Comparative study on alternative test voltages for layered medium voltage cables*, ISH'91, Dresden, 26-30 August 1991.