

Double-curved panels produced in a flexible mould with self-compacting fibre-reinforced concrete

Steffen Grünewald^{1,2}, Roel Schipper¹, Dick Hordijk¹

1: Department of Structural and Building Engineering, Delft University of Technology, The Netherlands

2: Magnel Laboratory for Concrete Research, Ghent University, Ghent, Belgium

The number of applications with thin flat, curved or double-curved elements often produced as architectural elements for façades is rising fast. If the repetition factor of the elements is limited, which is often the case in free-form architecture, the high number of unique moulds makes this type of architecture economically less viable. Furthermore, a large volume of waste is produced through milling as a consequence of the production of unique elements. The reinforcement of thin panels poses specific demands on the material selection and production process, which directly affects their structural performance. This paper discusses a flexible mould technique, which has been developed in order to produce thin double-curved elements with concrete. Fibres are added to provide strength and ductility, the degree to what was determined by flexural testing of prisms and point-loading of thin plates.

Keywords: Flexible mould, quality criteria, fibres, self-compacting concrete, high-performance concrete, flexural behaviour

1 Introduction

Architecture with curved geometry, found for example in domes and vaults and later also in shell structures, has been appreciated throughout the centuries because of their inspiring and appealing shapes and structural benefits; in the last decades of the previous century these type of structures have become more and more rare. Three parallel developments have recently refreshed the interest for complex and double-curved geometry: 1) recent CAD-paradigms offer strong tools for parametric and complex-shaped 3D-modelling, 2) rapidly improving computational power of engineering tools enable the structural analysis of these shapes and 3) these technological boosts enable and inspire architects and structural designers to apply such shapes in real buildings and structures, shapes that are beautiful and functional at the same time [1]. In addition, recent developments in concrete technology, such as ultra-high performance concrete (UHPC), self-compacting concrete (SCC) and the thorough understanding of rheology, allows using concrete for lightweight highly complex-shaped structures. Timber, steel and plastic composites have been used to produce formwork for double-curved elements; in many cases, the CNC-milling technique was applied. However, free-form buildings still tend to be expensive.

With the use and re-use of a flexible system, the desired shapes can be realised and formwork waste avoided. The main targets for the development of the flexible mould technique at Delft University of Technology was the optimization of the production process and the realization of complex shapes with an economical and accurate reuseable system. High and ultra-high strength concretes with initial self-compacting consistency have been applied to produce thin panels. Because of the slenderness and relatively low weight of thin panels they can also be used as an alternative solution for protecting, reinforcing or secondary load-carrying layers. Thin façade panels attached to a structure can be loaded for example in bending (global behaviour) and very local by punching or anchorage forces (local behaviour). The use of fibres to reinforce panels is very effective compared to other alternatives like the placement of textiles or steel reinforcement. During the production of elements with the flexible mould technique, reinforcement also has to follow the deformation of the formwork.

2 Flexible mould technique

In order to reduce formwork costs and to realise complex shapes with concrete, a flexible mould system need to be reusable, adjustable and robust. The shape of the formwork can be changed after each casting; the supporting edges of the mould can be positioned in very different arrangements on the mould surface. The principle of the flexible mould system is shown in Figure 1. The six steps are: (1) the support structure of the mould is positioned according to the design coordinates; the mould bottom is carried by a secondary load-carrying frame, (2) the mould is filled with SCC; fibres or textiles can be used as reinforcement, (3) structural build-up of concrete in the plastic stage increases the yield strength during the rest period, (4) the mould is carefully deformed into its final shape, (5) concrete hardens in the deformed mould and finally, (6) the curved element is demoulded.

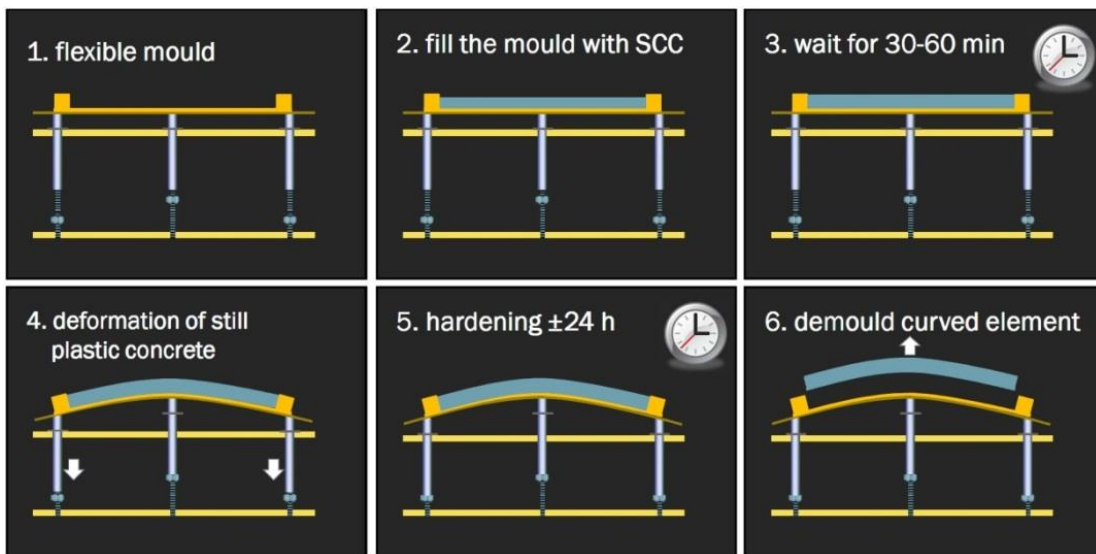

Figure 1: Different steps of the production of a curved element with the flexible mould system [2].

Critical aspects for the flexible mould technique are the design of the support structure, the bottom and walls of the mould and the rheological characteristics of the concrete. During the deformation of the mould, strains and stresses are the result of the curved shape. Deforming a flat surface into a double-curved surface is fundamentally impossible, unless large strains in the plane of the mould can occur through the use of a very elastic mould and deformable support layer [3]. The use of such an elastic layer, however, inherently results in the contradiction that the discrete grid of vertically adjustable actuators supporting the mould, might become visible in the resulting concrete panel. On the one hand, flexibility is required, on the other hand, stiffness is also a necessity. Eigenraam [4] improved the initial mould system allowing more flexibility and it offers better control and accuracy of the support structure. A recent patent describes the mould system that made this control and accuracy possible [5]. Although the basics are relatively simple, the system could as well be combined with a computer-controlled apparatus for height control, such as the Pinbed Wizard, of which recently a working prototype was completed [6]. This system has advantages with regard to the production capacity. For the realization of any building of serious scale hundreds to thousands panels need to be produced. Figure 2 shows examples of successfully deformed double-curved (left) and curved (right) elements. Though it should be realised that upscaling of a mould poses more stringent demands with regard to its capacity to transfer strains and to carry loads.

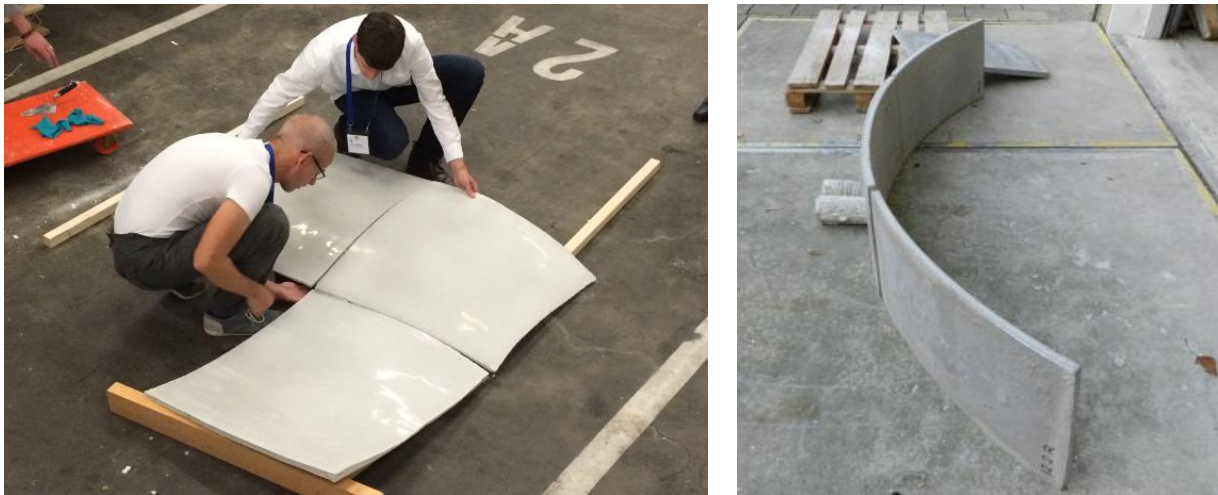

Figure 2: Two configurations of deformed double-curved (left) and single-curved (right) panels.

The rheological characteristics of the concrete, and thixotropy in particular, are key properties for the production of a panel with the deformed mould. After mixing, the concrete has to be self-compacting in order to be cast without compaction energy. In time, the yield strength increases due to the reversible and non-reversible structural build-up of the concrete, which is schematically shown as a linear increase in Figure 3a. According to [7], the hardening process does not significantly affect the yield strength during the ‘dormant period’ (the first one or two hours after adding water to the cement). However, Roussel et al. [8] showed that in thixotropic mixtures early hydration (CSH-nucleation starting directly after mixing) certainly is responsible for a far larger part of the thixotropic behaviour than colloidal effects. CSH-bridges can still be broken relatively easy, and will rebuild at rest as long as sufficient reactive material is available, which explains the thixotropic behaviour that is observed at the macro-scale. The tensile strain of concrete after the deformation of the mould is the largest at the outer fibre of the cross-section and at the location with the largest curvature (= the smallest radius). The deformability of concrete decreases in time. The decrease is small in the early age phase and decrease more rapidly when setting initiates; this behaviour is idealised by the dashed line in Figure 3b. Depending on the curvature of the element and the slope of the concrete, an ‘open window’ is obtained to deform the mould, which is more narrow for a larger slope.

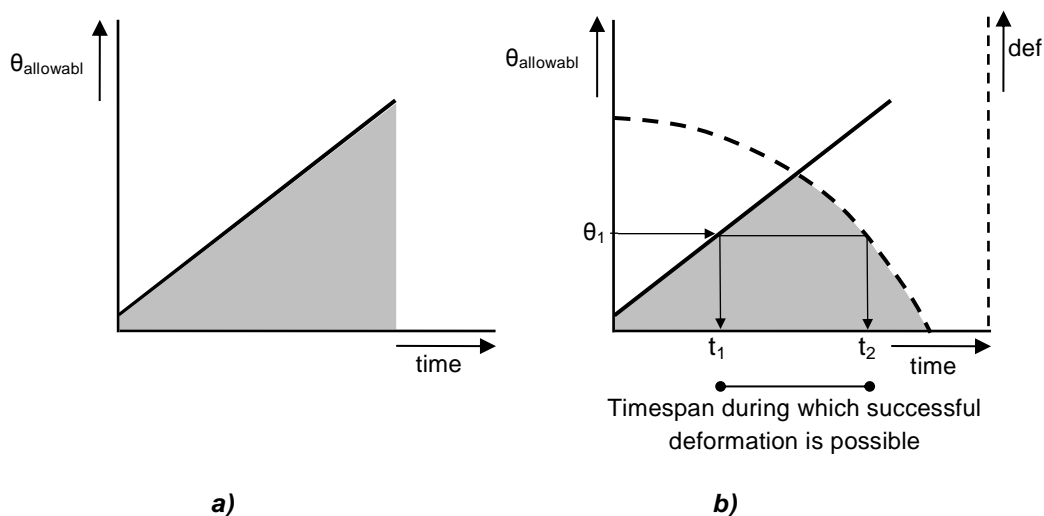

Figure 3: Increase of yield strength of concrete in time (a) and decrease of deformability and timespan to deform the mould (b) [9].

Figure 3 illustrates that, at a given slope of the concrete (angle θ_1), the mould cannot be deformed earlier than t_1 , which is the lower boundary for the moment of deformation. At this moment, deformation is still possible since the strength of the CSH-bonds is limited. However, these bonds will, at a certain instant, have grown so strong that plastic deformation of the concrete is no longer possible. This is the moment t_2 and it is the upper boundary; the moment t_2 after casting depends on both the curvature and the thickness of the element.

3 Mixture development

For the production of double-curved elements with a flexible mould the requirements for the mix design concern production aspects as well as the structural capacity of the elements. The feasibility of the flexible mould technique was tested with a variety of mixtures. A SCC with high fluidity, sufficient segregation resistance as well as a very high strength was developed, which allowed the addition of a high fibre dosage. Such a mixture can be applied in combination with the flexible mould method, and, after hardening, offers sufficient strength and stiffness needed, for example, for double-curved façade elements that were discussed above. Table 1 shows the mixture applied for the flexural tests (Mix A) and the three mixtures (Mix 1-3) that were applied to produce thin plates (Chapter 4). Since the fibre type applied for Mix A was not available anymore when Mix 1-3 were produced, the same fibre factor (= the product of fibre volume times the aspect ratio L_f/d_f) as for Mix A was maintained for Mix 3, which became the 100% fibre content. The fibre content of Mix 2 is 50% of Mix 3. The addition of 155 kg/m³ steel fibres resulted in an increase in compressive strength at 56 days after casting of 16,1 MPa (10,9 %), when compared to the reference mixture without fibres. At the highest fibre dosage (Mix 3) the splitting tensile strength was 17,4 MPa, which is a strength increase of 38 % compared to the reference mixture without fibres (Mix 1).

Table 1: Mixture composition of SCC with and without steel fibres.

Component		Mix A	Mix 1	Mix 2	Mix 3
CEM I 52.5 R	[kg/m ³]	358	358	358	358
CEM III/A 52.5	[kg/m ³]	555	555	555	555
Silica fume	[kg/m ³]	61	61	61	61
Sand (0.125-0.5)	[kg/m ³]	549	574	562	549
Sand (0.5-1.0)	[kg/m ³]	549	574	562	549
Steel fibres (13/0.16)	[kg/m ³]	125	0	0	0
Steel fibres (13/0.20)	[kg/m ³]	0	0	77,5	155
Superplasticizer	[kg/m ³]	21,0	21,0	21,0	21,0
Total water (incl. superplasticizer)	[kg/m ³]	226	226	226	226
Water/cement-ratio	[-]	0.25	0.25	0.25	0.25
Compressive strength, 56 d	[MPa]	-	148,1	144,7	164,2
Splitting tensile strength, 56 d	[MPa]	-	12,6	16,4	17,4

Three-point flexural tests (four prisms of $600 \cdot 150 \cdot 150 \text{ mm}^3$) were conducted to determine the load-displacement relation. The span between the two supports was 500 mm; the notch in the middle of the beam had a depth of $25 \pm 1 \text{ mm}$. Two Linear Variable Displacement Transducers (LVDT) with a measuring length of 100 mm were arranged at the tip of the notch (front and back side) in order to determine the horizontal displacement. The experiments were carried out deformation-controlled at a constant rate of deformation of $50 \text{ } \mu\text{m/s}$; a test was stopped when the load was below 0.2 kN. The control signal was the average of both LVDT-measurements. Figure 4 summarises the results of four flexural tests. The average load curve has a maximum of 73 kN (variation at the displacement of the maximum load is 7.5%), which translates to an equivalent flexural strength $f_{fctm,fl}$ of 23.4 MPa.

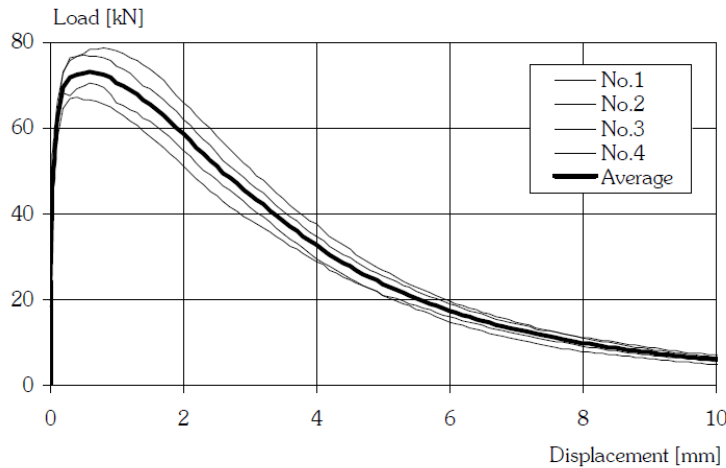

Figure 4: Flexural results and average of four prisms produced with SCC containing 125 kg/m^3 steel fibres.

The multi-layer procedure of Hordijk [10] was applied to determine the material behaviour in tension based on a recalculation of the flexural behaviour with inverse analysis. The multi-layer procedure starts with the assumption of a finite number of layers (500 layers in this case), by variation of strains and the required balance of forces the bending moment was calculated. A crack opening was converted to a strain by assuming an influence length of half the remaining beam height above the notch. In tension, a combined stress-strain/stress-crack width behaviour (Figure 5) was assumed.

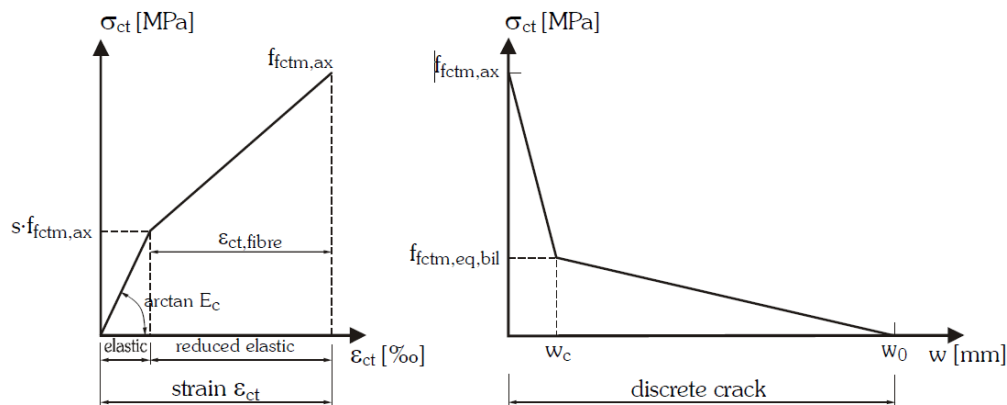

Figure 5: Combined stress-strain/stress-crack width model in tension applied for the inverse analysis.

The applied model consists of three parts: 1) one that accounts for the elastic behaviour of the beam, 2) one that allows taking into account a reduced elastic stiffness and to model flexural hardening and 3) a stress-crack width relation. Input for the analysis were the compressive strength (122.3 MPa) and the modulus of elasticity (45700 MPa), which were determined on

prisms in compression. The bending response was fitted up to the displacement at which the bending load was lower than 0.2 kN. Four accuracy checks were carried out; the deviation of each check had to be lower than 4%. The checks (simulation/experiment) were executed for the flexural loads (at the maximum and 75% of the experimental maximum load) and the fracture energy (up to 75% of the experimental maximum load and up to 10 mm). Table 2 shows the obtained tension model parameters from the inverse analysis.

Table 2: Model parameters for SCC containing 125 kg/m³ steel fibres.

	$S \cdot f_{ctm,ax}$ [MPa]	$\varepsilon_{ct,fibre}$ [‰]	$f_{ctm,ax}$ [MPa]	W_C [mm]	$f_{ctm,eq,bil}$ [MPa]	W_0 [mm]
Mix A	8.23	1.0	9.60	2.3	4.02	4.8

4 Testing of thin panels

The performance of 15 mm thin panels cast with SCC (with or without steel fibres) was determined by locally applying a point load (Figure 6). In total, six thin plates (dimensions: 600·600·15 mm³) were produced and tested. The dosage of steel fibres (straight, $L_f=13$ mm, $d_f=0,20$ mm) was varied (0; 0,99 and 1,97 Vol.-%); two plates were produced with the mixtures shown earlier in Table 1. A welded frame with four adjustable supporting columns (area of plate: 30·30 mm²) was arranged in a quadratic layout (600·600 mm²); the columns supported a plate at its four edges. The frame was sufficiently stiff in order to prevent deformations and the displacement of the supports. The top of each column consisted of a steel plate (40·40·15 mm³) welded on a M24-bolt in order to be able to adjust the height of the supports. The contact area of the loading head of the testing machine and the plates had the dimensions of 25·25 mm². The tests were carried out deformation-controlled; the load and the deflection of a plate (at the loading head) were continuously recorded during testing.

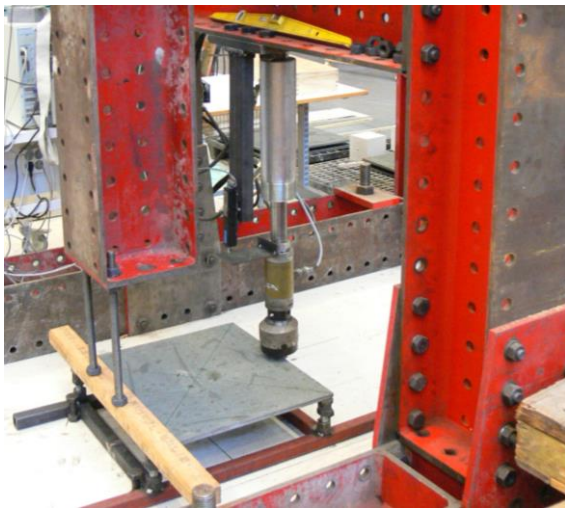

Figure 6: The testing machine with a thin plate placed on four supports; the loading head is placed between two supports at the edge of the plate.

SCC (volume: 60 litres) was prepared with a forced-pan type mixer. The casting method (Figure 7) was chosen to optimize the performance of the fibres by aligning them in the direction of principal stresses. Self-levelling concrete was filled in a bucket and the formwork was filled according to the casting procedure indicated by Figure 7. The most critical loading point of the plate was assumed to be at the edge in the middle of the span between the supports; fibres aligned parallel to the walls of the formwork improve the load-bearing capacity in this loading case. The fibres orient due to the flow through the bucket and due to the free flow in the mould

mainly parallel to the walls of the formwork. The slump flow was 799 mm (Mix 1, without fibres), 752 mm (Mix 2, $V_f=77,5 \text{ kg/m}^3$) and 688 mm (Mix 3, $V_f=155 \text{ kg/m}^3$).

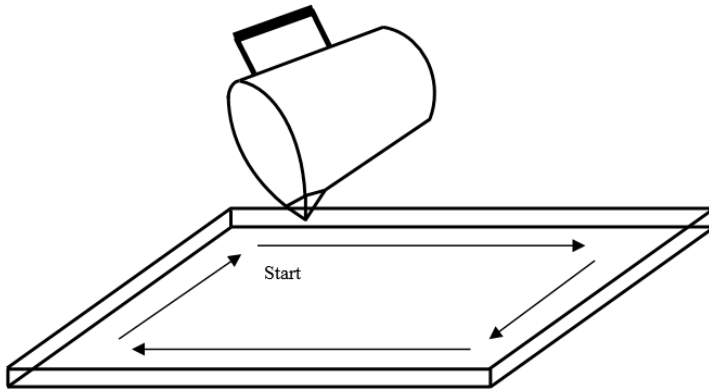

Figure 7. Applied filling procedure for thin plates.

The six plates were tested 56 days after casting; Figure 8 presents the load-deflection results. The fibres (Plates 3 to 6) significantly increased the maximum load and ductility of the plates compared to the reference plates (Plates 1 and 2). The load-increase (average of two results) was 393% relative to the maximum load obtained with the reference plates (without fibres) with 50% of the maximum fibre dosage and 507% with 100% of the maximum fibre dosage, respectively. The improvement of the maximum flexural strength with $77,5 \text{ kg/m}^3$ additional fibres was only 29% (fibre content 1,97 Vol.-% compared to 0,99 Vol.-%).

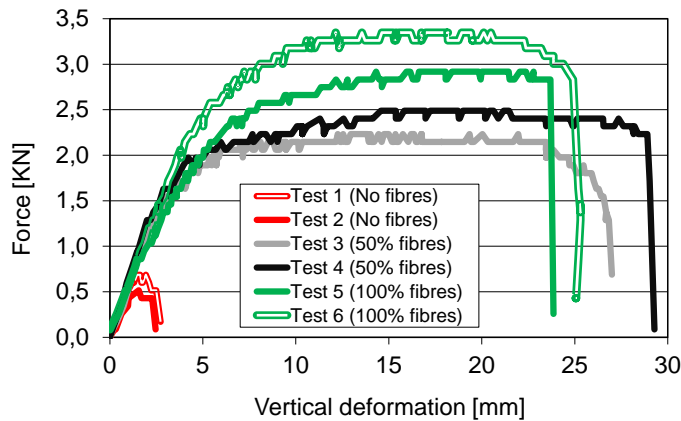

Figure 8: Load-deflection diagram for six plates: concentrated loading of thin plates.

The deflection at the maximum load is the sum of the elastic deformation of the plate and a local deformation (by opening of cracks) close to the loading head. Figures 9a and 9b show the failure pattern of respectively Plate 1, without fibres and Plate 6, with fibres. Plates 1-2 failed brittle in bending with a single crack running through the middle of the plate between the supports (Figure 9a shows Plate 1). The maximum load for the two plates without fibres was only 0,52 kN (Plate 2). In contrast, Plates 3-6 locally failed in the vicinity of the loading head. Figure 9b shows Plate 6 with a fibre dosage of $V_f=155 \text{ kg/m}^3$. When a plate contained fibres, only a relative small part of the plate was pushed down by the loading head. The flexural strength of Plate 6 was the highest of all plates (maximum load of 3.3 kN). Compared to the other plates relatively more fibres crossed the cracks of Plate 6 around the loading position. A secondary crack surface was observed only for Plate 6 (Figure 9b: in the middle of the pushed down part), which contributed to the load-bearing capacity.

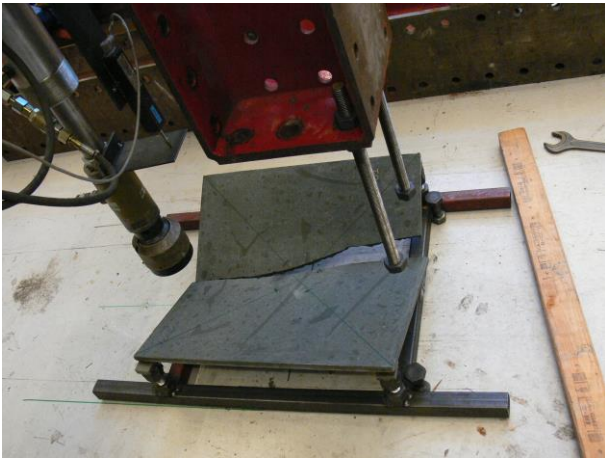

Figure 9a: Failure pattern of Plate 1 after the execution of the test.

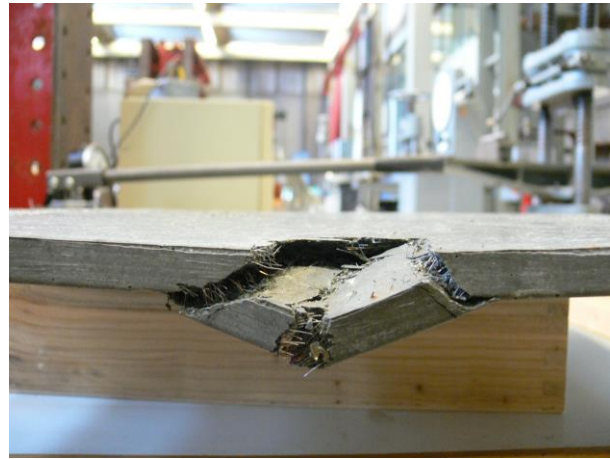

Figure 9b: Horizontal view on Plate 6 after the execution of the test.

5 Conclusions

With the flexible mould technique thin curved and double-curved concrete panels can be produced at lower costs and with less waste compared to CNC-milled formwork. Especially, projects with a larger number of unique elements can benefit from this technique. The mix design and rheological characteristics of concrete can be adopted in order to match with the demands concerning element geometry and required production robustness. The flexural performance of thin plates can be significantly improved by the addition of steel fibres, which improved both the global and local performance of thin panels.

References

- [1] Scheurer, F.: Materialising Complexity, *Architectural Design*, John Wiley & Sons, 80, p. 86-93, 2010.
- [2] Schipper, H.R.: Double-curved precast concrete elements – Research into the technical viability of the flexible mould method, PhD-thesis, Department of Structural and Building Engineering, Delft University of Technology, ISBN: 978-94-6299-154-5, 2015.
- [3] Schipper, H.R., Janssen, B.: Curving Concrete - A Method for Manufacturing Double Curved Precast Concrete Panels using a Flexible Mould, Proceedings of the IABSE-IASS conference, London, 2011.
- [4] Eigenraam, P.: Flexible mould for production of double-curved concrete elements, Master-thesis, Delft University of Technology, 2013.
- [5] Eigenraam, P., Schipper, H.R.: Patent NL2011770C: Apparatus for forming a curved panel from a flat panel, <http://worldwide.espacenet.com>, 2015.
- [6] FD Technologies: Adjustable mould, <http://fdtechnologies.eu/>, 2015.
- [7] Van Breugel, K.: Simulation of Hydration and Formation of Structure in Hardening Cement-Based Materials, Delft University Press, 1997.
- [8] Roussel, N.; Ovarlez, G.; Garrault, S., Brumaud, C.: The origins of thixotropy of fresh cement pastes, *Cement and Concrete Research*, 42, p. 148-157, 2012.
- [9] Grünewald, S., Janssen, B., Schipper, H.R., Vollers, K.J., Walraven, J.C.: Deliberate deformation of concrete after casting, International Conference on Flexible Formwork, Bath: University of Bath, p. 132-139, 2012.
- [10] Hordijk, D.: Local approach to fatigue of concrete, PhD-thesis, Department of Structural and Building Engineering, Delft University of Technology, 1991.