

Document Version

Final published version

Licence

CC BY

Citation (APA)

Hostinský, V., Sodja, J., Jebáček, I., & Navrátil, J. (2024). Unified model of sandwich panel core and faces for aeroelastic optimization. In *Aeroelasticity & Structural Dynamics in a Fast Changing World 17 – 21 June 2024, The Hague, The Netherlands* Article IFASD 2024-133

Important note

To cite this publication, please use the final published version (if applicable).
Please check the document version above.

Copyright

In case the licence states “Dutch Copyright Act (Article 25fa)”, this publication was made available Green Open Access via the TU Delft Institutional Repository pursuant to Dutch Copyright Act (Article 25fa, the Taverne amendment). This provision does not affect copyright ownership.
Unless copyright is transferred by contract or statute, it remains with the copyright holder.

Sharing and reuse

Other than for strictly personal use, it is not permitted to download, forward or distribute the text or part of it, without the consent of the author(s) and/or copyright holder(s), unless the work is under an open content license such as Creative Commons.

Takedown policy

Please contact us and provide details if you believe this document breaches copyrights.
We will remove access to the work immediately and investigate your claim.

UNIFIED MODEL OF SANDWICH PANEL CORE AND FACES FOR AEROELASTIC OPTIMIZATION

Vladimír Hostinský¹, Jurij Sodja², Ivo Jebáček¹ and Jan Navrátil¹

¹ Institute of Aerospace Engineering, Brno University of Technology, Czechia

² Aerospace Structures & Materials, Technical University Delft, Netherlands

Keywords: metamaterials, honeycombs, aeroelastic tailoring, sandwich panel

Abstract: Metamaterials show a considerable potential in the field of complex optimization of aerospace structures. To fully exploit this potential, the authors present a novel approach to modeling the structural response of a sandwich panel with metamaterial core and CFRP skins that could be used within a single-step optimization process. The proposed approach is illustrated using a model of a panel with aluminum honeycomb core. Obtained results confirm the high potential of the inclusion of the core optimization into the optimization framework. Simple preliminary validation utilizing the finite element analysis presented in the closure of this study yielded a satisfactory agreement with the results of the proposed analytical model. The maximum reached difference of five percent can be attributed to a different shape of deformation of the honeycomb core within the sandwich as opposed to a deformation of the honeycomb core alone.

1 INTRODUCTION

A significant proportion of the total weight of any aircraft consists of the weight of its structural components. Any reduction in the weight of the structure can result in a notable increase in either the useful payload or the fuel efficiency of the aircraft, which in turn can lead to a significant reduction in the cost and environmental impact of its operations. This creates a need to fully exploit the potential of any material used in aerospace structures not only through the optimal shaping of the structural components but also through precise optimization of the properties of the material itself. This tailoring approach has already been extensively researched in association with laminate composite structure design.

The recent developments in additive manufacturing and computer-driven manufacturing have revealed new possibilities for tailoring other bulk materials, such as aluminum alloys, titanium alloys or polymers. This has led to the creation of a new class of cellular materials, known as mechanical metamaterials [1-4], whose mechanical properties can be altered by modifying the geometry of the material cells. Due to the nature of their manufacturing, the majority of metamaterials are based on polymers or titanium and aluminum alloys, which limits their ability to compete with the high strength-to-weight ratio and levels of anisotropy achievable by CFRP composites. However, they could be utilized effectively to complement these materials and expand the scope of optimization by creating fully optimized hybrid structures.

The potential advantages of integrating mechanical metamaterials and carbon fiber-reinforced polymer (CFRP) composites into aircraft structural design can be investigated by implementing both into a state-of-the-art aeroelastic optimization framework that will optimize a structure consisting of sandwich panels with a metamaterial core and CFRP skins. Previous research in the field of sandwich optimization employs a two-step approach for the optimization of the skin and core of the sandwich panel [5]. In the context of aeroelastic design, core

optimization is limited to the use of a core with fixed properties [6], a core with variable thickness [7], and a core made of functionally graded foam [8].

This study proposes a novel model of a hybrid sandwich that will allow simultaneous single-step optimization of metamaterial core and CFRP skins by describing the material through a combination of skin lamination parameters and geometrical properties of the core. The novel approach is based on a combination of existing models that utilize a fixed number of design variables. This allows for the implementation of a gradient-based optimizer, which is frequently used in the preliminary design optimization of aerospace structures.[9,10]

One of the major challenges of introducing a new material into the design process is the lack of models that describe its behavior. To avoid this problem, a honeycomb core was chosen as an example of a metamaterial with well-described behavior and a large enough number of design parameters that can be used as optimized variables.

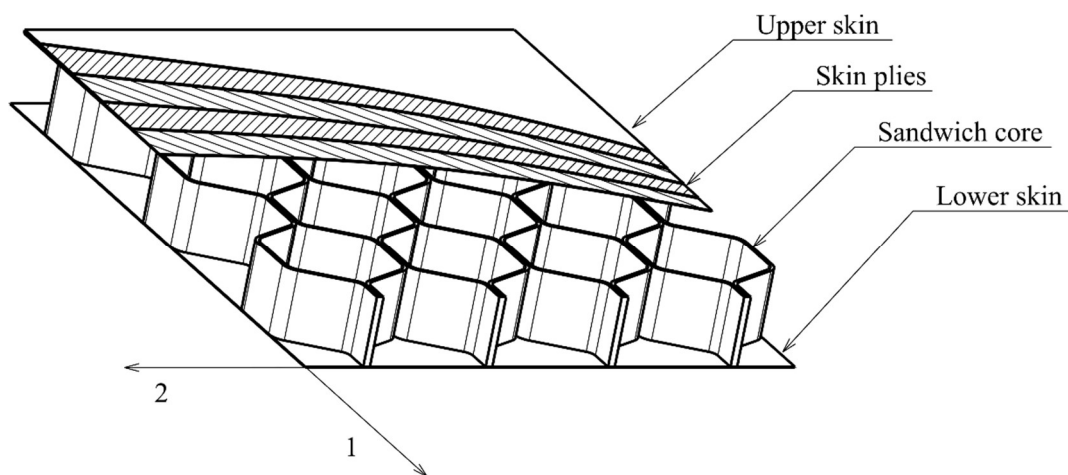

Figure 1: Sandwich components and main material directions.

Authors present a model of a sandwich panel with the commonly used combination of CFRP skins and an aluminum alloy honeycomb core (Fig. 1), based on the sandwich stiffness calculation approach described by Silva et al. [11] The lamination parameter approach [12] is used to describe the structural response of the skins, the homogenized mechanical properties of the honeycomb core are obtained using an analytical model of double-walled honeycomb properties developed by Masters and Evans [13]. The final model will be able to calculate a stiffness matrix of the sandwich panel based on the fixed number of design variables (core geometrical properties, skin lamination parameters and thickness) and constant material properties of the honeycomb core and laminate skin.

To validate the proposed approach, the stiffness properties of several core geometries obtained by the proposed framework were compared to those of finite element models of the sandwich panel with the same initial geometry and layout.

2 PROPOSED MODEL

The proposed model can be divided into two submodels, one describing the behavior of the skins and the other representing the core, both using **A**, **B** and **D** stiffness matrices to represent the resulting structural response of the corresponding component. To obtain a single

set of stiffness matrices of the sandwich panel, the component stiffness matrices are transposed using offsets integrated into Classical Laminate Theory (CLT) as described later in the article.

2.1 Skin submodel

To satisfy the need for a fixed number of design variables imposed by the intended use within an optimization framework based on a gradient-based optimizer, the skin submodel uses lamination parameters to describe the skin layout. This approach, first proposed by Tsai and Hahn [14], uses 12 lamination parameters, 5 material invariants, and a skin thickness to fully describe any laminate layout.

The lamination parameters can be divided into three types corresponding to the in-plane, out-of-plane, and coupled structural response of the laminate. For a laminate layout with constant ply thickness, the 12 lamination parameters can be obtained from the following equations [15]:

$$V_1^A, V_2^A, V_3^A, V_4^A = \frac{1}{N} \sum_{i=1}^N \cos(2\theta_i), \sin(2\theta_i), \cos(4\theta_i), \sin(4\theta_i) \quad (1)$$

$$V_1^B, V_2^B, V_3^B, V_4^B = \frac{2}{N^2} \sum_{i=1}^N (Z_i^2 - Z_{i-1}^2) (\cos(2\theta_i), \sin(2\theta_i), \cos(4\theta_i), \sin(4\theta_i)) \quad (2)$$

$$V_1^D, V_2^D, V_3^D, V_4^D = \frac{4}{N^2} \sum_{i=1}^N (Z_i^3 - Z_{i-1}^3) (\cos(2\theta_i), \sin(2\theta_i), \cos(4\theta_i), \sin(4\theta_i)) \quad (3)$$

where N is the number of plies in the laminate, $Z_i = -N/2 + i$ and θ_i is the fibre angle of ply i .

Furthermore, the following set of equations, based on the approach introduced by Tsai and Pagano [12], is used to establish a relationship between the A, B, and D matrices and the lamination parameters:

$$\mathbf{A} = h(\mathbf{\Gamma}_0 + \mathbf{\Gamma}_1 V_1^A + \mathbf{\Gamma}_2 V_2^A + \mathbf{\Gamma}_3 V_3^A + \mathbf{\Gamma}_4 V_4^A) \quad (4)$$

$$\mathbf{B} = \frac{h^2}{4} (\mathbf{\Gamma}_1 V_1^B + \mathbf{\Gamma}_2 V_2^B + \mathbf{\Gamma}_3 V_3^B + \mathbf{\Gamma}_4 V_4^B) \quad (5)$$

$$\mathbf{D} = \frac{h^3}{12} (\mathbf{\Gamma}_0 + \mathbf{\Gamma}_1 V_1^D + \mathbf{\Gamma}_2 V_2^D + \mathbf{\Gamma}_3 V_3^D + \mathbf{\Gamma}_4 V_4^D) \quad (6)$$

where h is the total thickness of the lamina, and matrices denoted by $\mathbf{\Gamma}$ are five material invariant matrices defined as follows:

$$\mathbf{\Gamma}_0 = \begin{bmatrix} U_1 & U_4 & 0 \\ U_4 & U_1 & 0 \\ 0 & 0 & U_5 \end{bmatrix}, \mathbf{\Gamma}_1 = \begin{bmatrix} U_2 & 0 & 0 \\ 0 & -U_2 & 0 \\ 0 & 0 & 0 \end{bmatrix}, \mathbf{\Gamma}_2 = \begin{bmatrix} 0 & 0 & U_2/2 \\ 0 & 0 & U_2/2 \\ U_2/2 & U_2/2 & 0 \end{bmatrix} \quad (7-9)$$

$$\mathbf{\Gamma}_3 = \begin{bmatrix} U_3 & -U_{-3} & 0 \\ -U_3 & U_3 & 0 \\ 0 & 0 & U_3 \end{bmatrix}, \mathbf{\Gamma}_4 = \begin{bmatrix} 0 & 0 & U_3 \\ 0 & 0 & -U_3 \\ U_3 & -U_3 & 0 \end{bmatrix} \quad (10,11)$$

The set of material invariants U_{1-5} represents the material properties independent of the laminate layout. As such, they can be described as functions of the ply stiffness matrix \mathbf{Q} , which is presented in [12]. Matrix \mathbf{Q} can be easily obtained from the predefined ply

properties, namely the in-plane elastic moduli in the main material directions, in-plane shear modulus, Poisson's ratio, and ply thickness.

The aforementioned process enables the skin submodel to calculate the stiffness matrices \mathbf{A} , \mathbf{B} , and \mathbf{D} , as defined by equations (4-6), through two distinct approaches. The matrices can be calculated directly using the predefined material invariant matrices Γ_{1-5} , laminate thickness h and 12 lamination parameters. This approach can be employed within the optimization process (Figure 4), offering the advantage of a fixed number of input variables. The second approach calculates the stiffness matrices using the full length of the process, commencing with predefined ply properties and laminate layout. This approach can be employed during a simple calculation of sandwich properties or the creation of an initial guess for use in the optimization process.

2.2 Parametrized model of the core

The honeycomb core geometry can be fully described by a set of seven parameters (Tab. 1, Fig. 2). When combined with the properties of the bulk material of the core, these parameters can be used to analytically predict the homogenized mechanical properties of the core, which are represented by stiffness matrices \mathbf{A}_c , \mathbf{B}_c and \mathbf{D}_c .

Double wall length	h	[mm]
Inclined wall length	l	[mm]
Wall thickness	t	[mm]
Core thickness	b	[mm]
Cell angle	θ_c	[°]
Core orientation within the sandwich	ϕ_c	[°]
Corner bend length	q	[mm]

Table 1: Geometric parameters describing the honeycomb core.

The most notable and widely used model is that of Gibson and Ashby [16], which was later refined and further validated by Malek and Gibson [17]. Although it offers a refined version for calculating the properties of more commercially available double-walled honeycombs [18], the model neglects the effects of the axial elastic elongation of cell walls. In practice, this renders the resulting homogenized in-plane properties the same for single-walled and double-walled honeycomb structures. The model utilized in this study, developed by Masters and Evans [13], predicts the homogenized properties by accounting for inclined wall bending, hinging in the cell corners and also the axial elongation of the walls. Although it has been proven inaccurate in the region of higher core densities [19], it is sufficiently precise for the intended use within the optimization of lightweight aerospace sandwich panels.

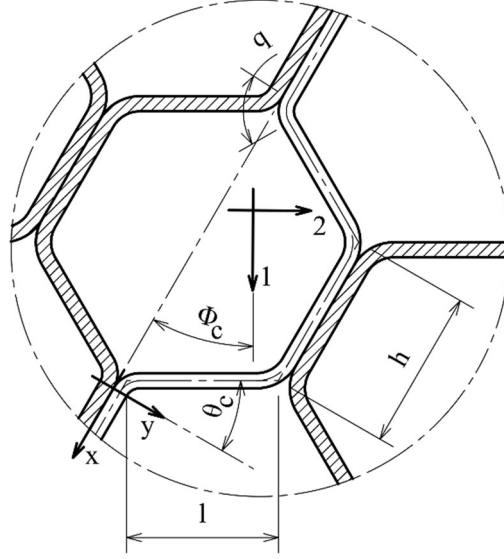

Figure 2: Honeycomb core geometry.

The model of Masters and Evans employed in this study employs a concept of force constants that relate the applied force to one of the three deformation modes (wall flexing, corner hinging, and wall stretching). In general, the force constant can be described by the following equation:

$$F = K_i \delta, \quad (12)$$

in which F is the applied force, K_i is the force constant and δ is the displacement. Three force constants corresponding to the three deformation modes can be related to the basic geometry of the core and the elastic modulus of the bulk material of the core E_s using the set of equations in Table 2. In calculation of the hinging force constant, it is assumed that local hinging is predominant over hinging by shear deformation, which is true for honeycomb cores with $t/l < 0.2$. [13]

Flexure force constant	$K_f = \frac{E_s b t^3}{l^3}$ (13)
Stretching force constant	$K_s = \frac{b t E_s}{l}$ (14)
Hinging force constant	$K_h = \frac{E_s b t^3}{6 l^2 q}$ (15)

Table 2: Force constants.

The three force constants can be combined with the equation (12) to estimate the total deformation of the core from which the homogenized properties of the core, consisting of the two in-plane moduli E_X and E_Y , in-plane shear modulus G_{XY} and Poisson's ratio ν_{XY} , can be easily derived as described in detail in [13].

The obtained material properties correspond with the coordinate system of the core (x,y in Figure 2). In order to obtain homogenized stiffness matrices of the core \mathbf{A}_C , \mathbf{B}_C and \mathbf{D}_C corresponding to the main material coordinate system (1,2 in Figure 2), the core is treated as a single ply

laminate with a ply angle ϕ_c , for which homogenized stiffness matrices of the core are calculated by employing basic principles of the CLT [14].

2.3 Sandwich representation

The stiffness matrices of the core and skins of the sandwich were calculated with respect to the central plane of the given sandwich component (e.g. upper skin or core). Silva and Meddaikar in [11] present a following approach to create a single set of stiffness matrices representing the homogenized properties of the sandwich panel:

$$A = \sum_{i=1}^N A_i \quad (16)$$

$$B_u = \sum_{i=1}^N B_{ui} - \frac{h_i}{2} A_{ui} \quad (17)$$

$$B_l = \sum_{i=1}^N B_{li} + \frac{h_i}{2} A_{li} \quad (18)$$

$$D = \sum_{i=1}^N D_i + h_o(B_{li} - B_{ui}) + \frac{h_i^2}{4} A_i \quad (19)$$

The matrices \mathbf{B}_i and \mathbf{D}_i of each sandwich component are offset by the distance between the sandwich central plane and the relative position of the component central plane h_i . Coupling matrices \mathbf{B}_{U_i} and \mathbf{B}_{L_i} correspond to the upper and the lower skin respectively. Note that $\mathbf{B}_U = -\mathbf{B}_L$ when the skin laminate layouts are symmetric to each other. The coupling stiffness matrix \mathbf{B} of the entire sandwich can be obtained by superposing coupling matrices of skins \mathbf{B}_U , \mathbf{B}_L and the coupling stiffness matrix of the core \mathbf{B}_C . To obtain \mathbf{A} , \mathbf{B} and \mathbf{D} matrix of a sandwich with a single core material and two skins, the equations (16-19) can be rewritten in the following way:

$$A = A_C + A_U + A_L \quad (20)$$

$$B = B_U - \frac{h_o}{2} A_U + B_L + \frac{h_o}{2} A_L \quad (21)$$

$$D = D_C + D_U + D_L + h_o(B_L - B_U) + \frac{h_o^2}{4} A \quad (22)$$

Where h_o is the offset thickness described in the Figure 3, which can be calculated as follows:

$$h_o = \frac{T}{2} + \frac{b}{2}$$

Where T is the overall thickness of the laminate skin and b is the thickness of the core.

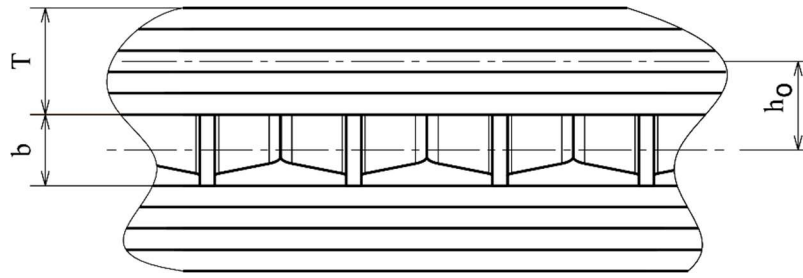

Figure 3: The offset thickness h_0

2.4 Model integration

Stiffness matrices obtained from equations (20-22) can be used to predict the homogenized material properties of a complex sandwich panel during structural analysis and optimization. An overall scheme of the model and its possible integration into the optimization framework is shown in the Figure 4.

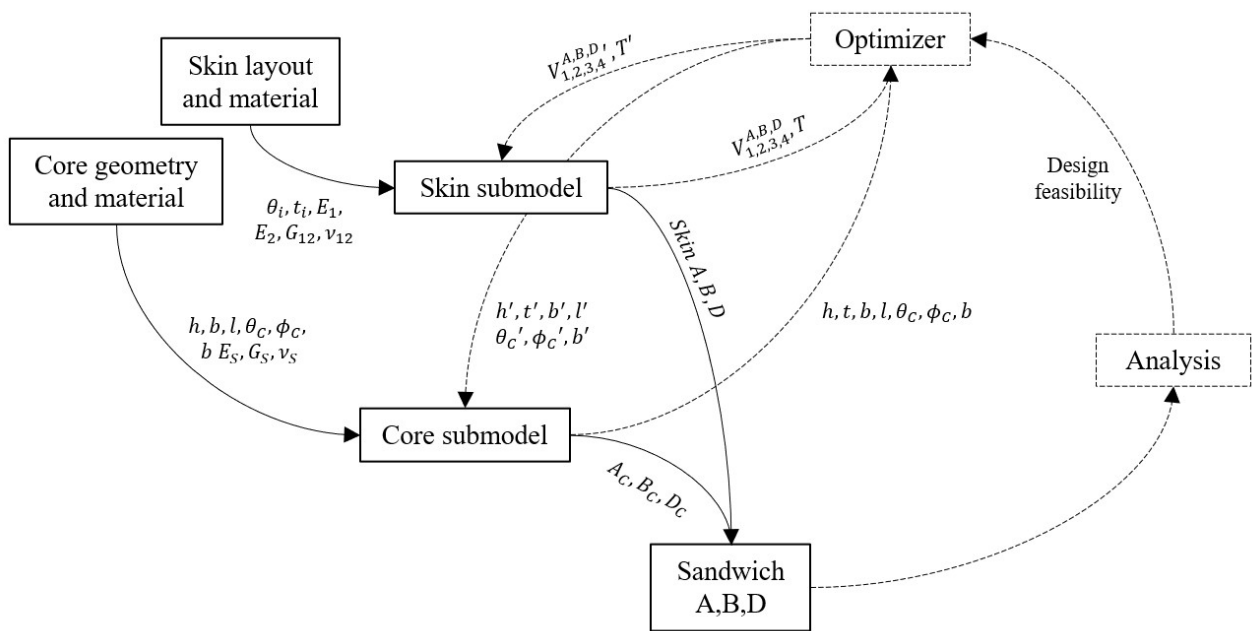

Figure 4: Model integration.

The gradient-based optimizer is provided with a set of 12 lamination parameters, skin thickness, 7 core design parameters and returns the optimized values of these parameters (marked with an apostrophe) based on the results of the analysis.

3 ANALYTICAL RESULTS

The newly created model was employed in a trade-off study to assess the potential impact of specific geometrical parameters of the honeycomb core on the outcomes of future optimization. The evaluation consisted of determining the homogenized properties of the typical sample panels with carbon fiber-reinforced polymer (CFRP) laminate skins and aluminum cores within a design space region defined by four variable core geometrical

parameters, as detailed in Table 3, and ten fixed parameters in Table 4. Four homogenized properties of the panel were evaluated across the selected design region: level of anisotropy E_1/E_2 , Poisson's ratio ν , flexural modulus E_{F1} and shear modulus G_{12} .

Parameter description	Denotation	Studied range
Double wall length to inclined wall length ratio	h/l	0.5 - 20
Wall thickness to inclined wall length ratio	t/l	0.01 - 0.1
Core thickness	b	0 - 50 mm
Cell angle	θ_c	-45 to 45°

Table 3: Trade-off study design parameters

l	10 mm	Upper skin layout	[45, -45, 0, 0, 0°]
ϕ_c	0°	Lower skin layout	[0, 0, 0, -45, 45°]
q	0.31	T	0.5 mm
E_S	70 GPa	E_{11}	100 GPa
G_S	26 GPa	E_{22}	20 GPa
		G_{12}	10 GPa

Table 4: Fixed properties of core (left) and skin (right)

The results presented in Figure 6 demonstrate a significant impact of the cell angle θ_c on the level of anisotropy E_1/E_2 , with a notable difference in the extreme values observed in both the lower t/l region (greater than 80%) and the higher t/l region (greater than 720%). Although accompanied by an increase in the relative density of the panel shown in Figure 7, this influence could be of significant importance during the future optimization of the panel and could be used to advantage to increase local directional stiffness.

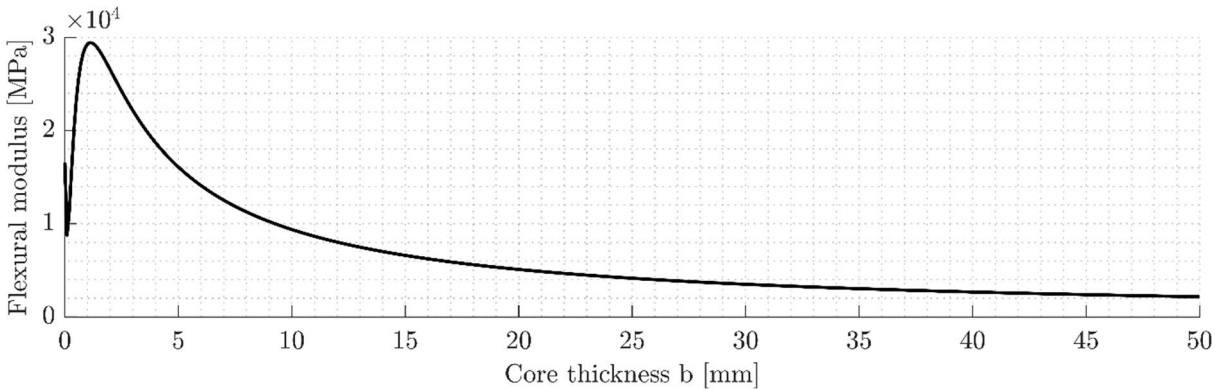

Figure 5: Dependency of flexural modulus on the core thickness b , $\theta_c=30^\circ$, $h/l=1$, $t/l=0.01$.

Another potentially advantageous phenomenon is the influence of the core thickness b on the homogenized flexural modulus shown in Figure 5. The data indicates a significant increase in the value of flexural modulus within a low thickness region. This suggests that the optimized panel could achieve an optimally high value of flexural stiffness without a significant weight penalty.

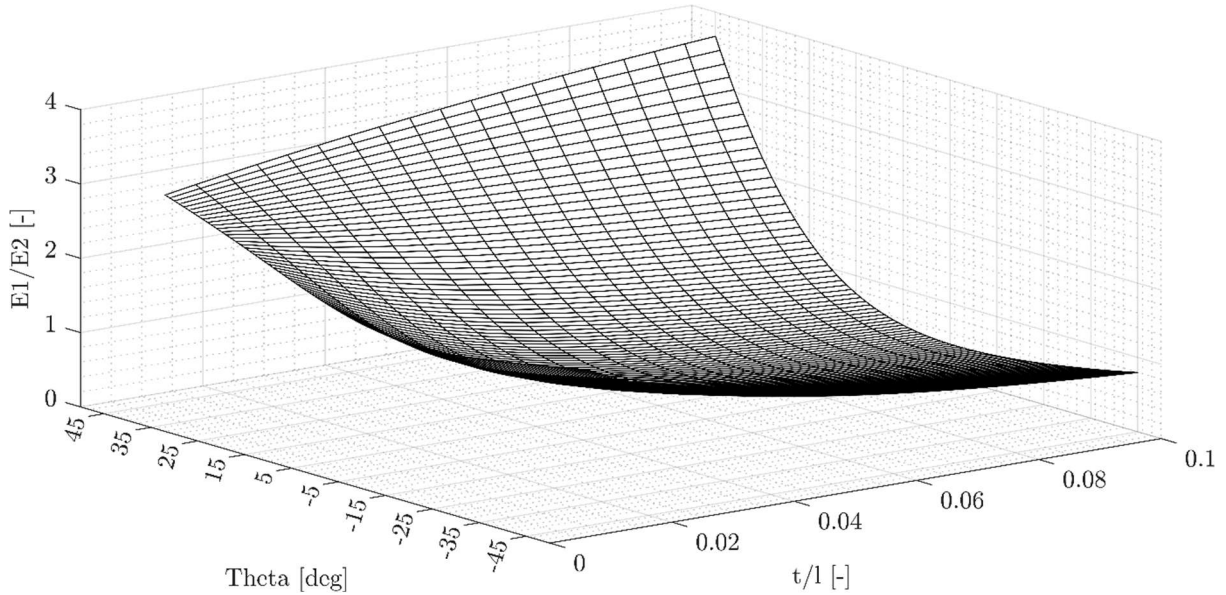

Figure 6: Influence of cell angle and t/l ratio on anisotropy level E_1/E_2 , $h/l=1$.

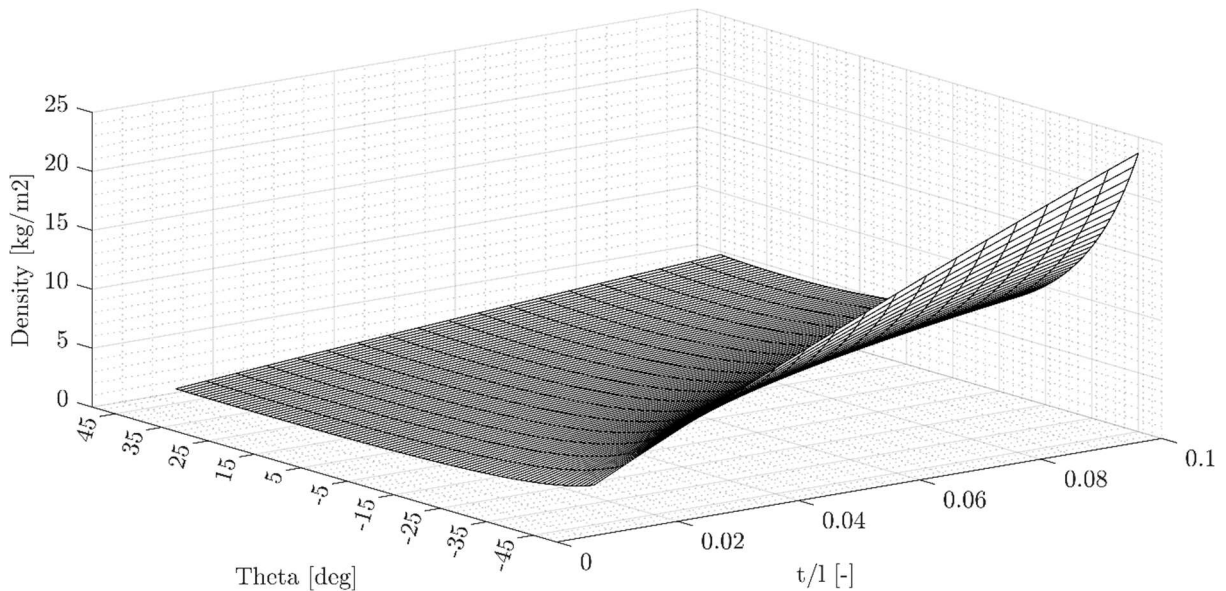

Figure 7: Influence of cell angle and t/l ratio on relative density of the panel, $h/l=1$.

4 PRELIMINARY VALIDATION

In order to validate the proposed model and presented results, finite element analysis was employed. A set of seven sample panels with carbon fiber-reinforced polymer (CFRP) laminate skins and aluminum cores, with differing core cell angles θ_c was selected to represent a portion

of the possible design space of the sandwich panel. The remaining properties of the panel were maintained at the values utilized in the preceding trade-off study (Table 4), with h/l fixed at a value of 1 and t/l set to 0.01.

The finite element models were constructed using quadrilateral shell elements with a maximum length of the element edge of 0.5 mm. The samples were subjected to a predefined displacement of 0.2% of the sample length. The resultant Young's moduli E_{1N} in direction 1 were then obtained based on the estimation of the force acting on the fixed constraint of the sample. A comparison with the moduli E_{1A} obtained from the analytical model can be seen in Figure 5 and Table 4.

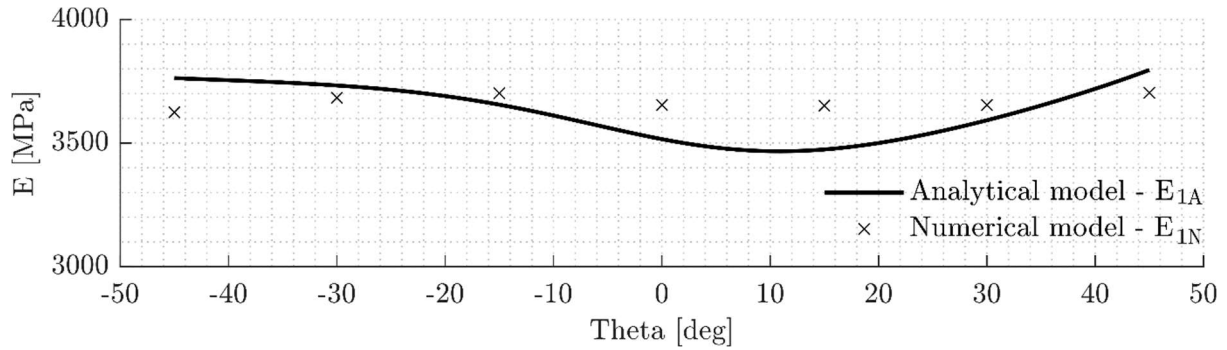

Figure 5: Result comparison

Sample	1	2	3	4	5	6	7
θ_c	-45°	-30°	-15°	0°	15°	30°	45°
E_{1A} [MPa]	3688	3703	3656	3549	3469	3523	3727
E_{1N} [MPa]	3625	3683	3702	3654	3652	3655	3704
δ	1.73%	0.54%	-1.23%	-2.88%	-5.01%	-3.61%	0.62%

Table 4: Validation results

The results of the validation demonstrate a satisfactory agreement between the obtained Young's moduli with a maximum difference of 5%, which is suitable for a preliminary design tool. The FEA results indicate a lower degree of dependency of the modulus on the cell angle. This phenomenon can be attributed to the shape of the core cell deformation within the sandwich. The cell walls in the honeycomb structure without skin (Figure 6 left) have a higher freedom to deform as a simple beam as modelled by the analytical approach while their displacement within the sandwich is more constrained (Figure 6 right).

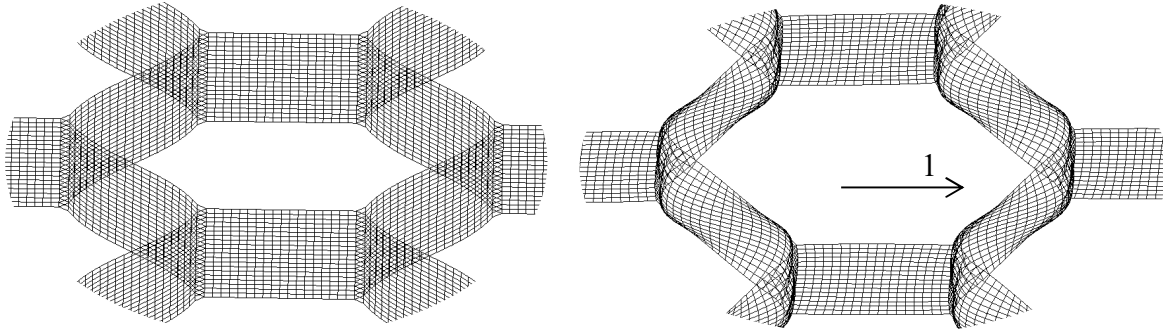

Figure 6: Deformed shapes of honeycomb cores subjected to a tension load in the direction 1. Core alone (left) and core within the sandwich (right).

Although this preliminary validation signifies a degree of agreement between the models, the complexity of the design space of the sandwich panel and their deformation behavior affected by the constraints of the sandwich skins necessitates a more comprehensive validation approach that would verify the precision of the proposed model through the entire design space, thus ensuring the reliability of the model within the optimization process.

5 CONCLUSIONS

This study presents an ongoing effort to model a sandwich panel with optimizable core and skins that can be used within a preliminary single-step optimization of aerospace structures. The proposed approach allows to represent any optimized sandwich structure by a fixed number of design variables and based on them can predict the in-plane elastic modulus of the sandwich with a precision that is satisfactory for use in the preliminary design optimization.

The results obtained by the model demonstrate a high degree of variability in the anisotropy levels achieved by the resulting panel, as well as the potential to reach the maximum flexural rigidity obtainable without a weight penalty. These behaviors confirm the high potential of hybrid structures used within the optimization process.

The complexity of the sandwich design space necessitates the implementation of more complex validation procedures to further verify the viability of the approach within the optimization process. Once the validation is complete, the proposed model, which has been supplemented with a set of analytical descriptions of sandwich panel failure modes, will be included in the process of aeroelastic optimization. The complete model should permit the optimization of a sandwich structure with any core metamaterial whose material properties can be homogenized and parametrized based on its geometrical properties and whose failure modes can be analytically described.

ACKNOWLEDGEMENTS

This work has been supported by the Horizon Europe program of the European Union under Grant Agreement No. 101079091 and the project No. FSI-S-23-8163 funded by The Ministry of Education, Youth and Sport (MEYS, MŠMT in Czech) institutional support.

REFERENCES

- [1] M. Kadic, T. Bückmann, R. Schittny, and M. Wegener, “Metamaterials beyond electromagnetism,” *Reports on Progress in Physics*, vol. 76, no. 12, p. 126501, Dec. 2013, doi: 10.1088/0034-4885/76/12/126501.

- [2] A. A. Zadpoor, “Mechanical meta-materials,” *Mater Horiz*, vol. 3, no. 5, pp. 371–381, Aug. 2016, doi: 10.1039/C6MH00065G.
- [3] X. Cheng *et al.*, “Design and mechanical characteristics of auxetic metamaterial with tunable stiffness,” *Int J Mech Sci*, vol. 223, Jun. 2022, doi: 10.1016/J.IJMECSCI.2022.107286.
- [4] X. Zheng *et al.*, “Multiscale metallic metamaterials,” *Nat Mater*, vol. 15, no. 10, pp. 1100–1106, Jul. 2016, doi: 10.1038/NMAT4694.
- [5] A. Catapano and M. Montemurro, “A multi-scale approach for the optimum design of sandwich plates with honeycomb core. Part I: homogenisation of core properties,” *Compos Struct*, vol. 118, no. 1, pp. 664–676, Dec. 2014, doi: 10.1016/J.COMPSTRUCT.2014.07.057.
- [6] P. Jin, B. Song, X. Zhong, T. Yu, and F. Xu, “Aeroelastic tailoring of composite sandwich panel with lamination parameters,” *Proc Inst Mech Eng G J Aerosp Eng*, vol. 230, no. 1, pp. 105–117, Jan. 2016, doi: 10.1177/0954410015587724.
- [7] P. Jin and X. Zhong, “Flutter Characteristic Study of Composite Sandwich Panel with Functionally Graded Foam Core,” *International Journal of Aerospace Engineering*, vol. 2016, 2016, doi: 10.1155/2016/7971435.
- [8] N. P. M. Werter and R. De Breuker, “A novel dynamic aeroelastic framework for aeroelastic tailoring and structural optimisation,” *Compos Struct*, vol. 158, pp. 369–386, Dec. 2016, doi: 10.1016/J.COMPSTRUCT.2016.09.044.
- [9] T. R. Brooks, G. Kennedy, and J. R. R. A. Martins, “High-fidelity Aerostructural Optimization of a High Aspect Ratio Tow-steered Wing,” in *57th AIAA/ASCE/AHS/ASC Structures, Structural Dynamics, and Materials Conference*, Reston, Virginia: American Institute of Aeronautics and Astronautics, Jan. 2016. doi: 10.2514/6.2016-1179.
- [10] G. H. C. Silva and Y. Meddaikar, “Lamination parameters for sandwich and hybrid material composites,” *AIAA Journal*, vol. 58, no. 10, pp. 4604–4611, 2020, doi: 10.2514/1.J059093.
- [11] S. W. Tsai and N. J. Pagano, “Invariant Properties of Composite Materials,” 1968. Accessed: Apr. 27, 2024. [Online]. Available: <https://apps.dtic.mil/sti/pdfs/AD0668761.pdf>
- [12] I. G. Masters and K. E. Evans, “Models for the elastic deformation of honeycombs,” 1996.
- [13] Stephen W. Tsai and Hong T. Hahn, *Introduction to Composite Materials*. CRC Press, 1980.
- [14] T. Macquart, N. Werter, and R. De Breuker, “Aeroelastic design of blended composite structures using lamination parameters,” in *Journal of Aircraft*, American Institute of Aeronautics and Astronautics Inc., 2017, pp. 561–571. doi: 10.2514/1.C033859.
- [15] L. J. Gibson and M. F. Ashby, *Cellular Solids*. Cambridge University Press, 1997. doi: 10.1017/CBO9781139878326.
- [16] S. Malek and L. Gibson, “Effective elastic properties of periodic hexagonal honeycombs,” *Mechanics of Materials*, vol. 91, no. P1, pp. 226–240, Dec. 2015, doi: 10.1016/j.mechmat.2015.07.008.

- [17] T. Bitzer, *Honeycomb Technology*. Dordrecht: Springer Netherlands, 1997. doi: 10.1007/978-94-011-5856-5.
- [18] S. Balawi and J. L. Abot, “The effect of honeycomb relative density on its effective in-plane elastic moduli: An experimental study,” *Compos Struct*, vol. 84, no. 4, pp. 293–299, Aug. 2008, doi: 10.1016/j.compstruct.2007.08.009.

COPYRIGHT STATEMENT

The authors confirm that they, and/or their company or organisation, hold copyright on all of the original material included in this paper. The authors also confirm that they have obtained permission from the copyright holder of any third-party material included in this paper to publish it as part of their paper. The authors confirm that they give permission, or have obtained permission from the copyright holder of this paper, for the publication and public distribution of this paper as part of the IFASD 2024 proceedings or as individual off-prints from the proceedings.