

Affordable Condominium Housing

A comparative analysis of low-income homeownership in Colombia and Ecuador

Donoso-gomez, Rosa

DOI

[10.7480/abe.2018.23](https://doi.org/10.7480/abe.2018.23)

Publication date

2018

Document Version

Final published version

Citation (APA)

Donoso-gomez, R. (2018). *Affordable Condominium Housing: A comparative analysis of low-income homeownership in Colombia and Ecuador*. [Dissertation (TU Delft), Delft University of Technology]. A+BE | Architecture and the Built Environment. <https://doi.org/10.7480/abe.2018.23>

Important note

To cite this publication, please use the final published version (if applicable).
Please check the document version above.

Copyright

Other than for strictly personal use, it is not permitted to download, forward or distribute the text or part of it, without the consent of the author(s) and/or copyright holder(s), unless the work is under an open content license such as Creative Commons.

Takedown policy

Please contact us and provide details if you believe this document breaches copyrights.
We will remove access to the work immediately and investigate your claim.



A3

Architecture
and the
Built environment

#23
2018

Affordable Condominium Housing

A comparative analysis of low-income homeownership in Colombia and Ecuador

Rosa Elena Donoso Gomez

Affordable Condominium Housing

A comparative analysis of low-income homeownership in Colombia and Ecuador

Rosa Elena Donoso Gomez

*Delft University of Technology, Faculty of Architecture and the Built Environment,
Department of OTB - Research for the Built Environment*



abe.tudelft.nl

Design: Sirene Ontwerpers, Rotterdam

ISBN 978-94-6366-076-1

ISSN 2212-3202

© 2018 Rosa Elena Donoso Gomez

All rights reserved. No part of the material protected by this copyright notice may be reproduced or utilized in any form or by any means, electronic or mechanical, including photocopying, recording or by any information storage and retrieval system, without written permission from the author.

Unless otherwise specified, all the photographs in this thesis were taken by the author. For the use of illustrations effort has been made to ask permission for the legal owners as far as possible. We apologize for those cases in which we did not succeed. These legal owners are kindly requested to contact the publisher.

Affordable Condominium Housing

**A comparative analysis of low-income
homeownership in Colombia and Ecuador**

Dissertation

for the purpose of obtaining the degree of doctor
at Delft University of Technology
by the authority of the Rector Magnificus prof. dr. ir. T.H.J.J. van der Hagen,
chair of the Board for Doctorates
to be defended publicly on
Friday 28 September 2018 at 10:00 o'clock

By

Rosa Elena DONOSO GOMEZ
Master of Science in Community and Regional Planning
University of Texas at Austin, United States of America
born in Guayaquil, Ecuador

This dissertation has been approved by the promotor

Composition of the doctoral committee:

Rector magnificus	chairperson
Prof. dr. ir. M.G. Elsinga	Delft University of Technology, promotor
Prof. dr. P.J. Boelhouwer	Delft University of Technology, copromotor

Independent members:

Prof. dr. B. Bengtsson	Uppsala University
Prof. dr. M.J. Oxley	Cambridge University
Dr. ir. C.J. Klaufus	University of Amsterdam
Prof. dr. E.M. van Bueren	Delft University of Technology
Prof. dr. H.D. Ploeger	Delft University of Technology

This PhD research project was supported by the Grant Award of EP-Nuffic,
Netherlands Fellowship Programme [NFP/PHD, CF7538/11] 2011-2015
Managed by the Valorisation Centre of Delft University of Technology

Contents (Concise)

Part I

- 1 Introduction to affordable condominium housing 35
 - 2 Conceptual approach 49
 - 3 Research design and methods 83
-

Part II

- 4 Housing market and affordable housing policy 111
 - 5 The formal institution: The horizontal property law 135
-

Part III

- 6 Professionals in provision of affordable condominiums 171
 - 7 Maintenance arrangements in condominium tenure:
The household perspective 213
 - 8 Conclusion: The balance between property
law and self-organization 235
-

Preface

In a highly urbanized future, it will be critical to know how to make high density housing in condominium ownership sustainable and resilient. With this in mind, it has been a privilege to be able to dedicate these years of PhD research to understanding collective ownership in condominiums. This thesis is just a starting point; there is still plenty of research to be done and comparisons to be made about condominium housing in cities around the world.

I am grateful that I found OTB at TU Delft, where I was able to realize this project, and my promotors Prof. Marja Elsinga and Prof. Peter Boelhouwer, who supervised and guided my research, helping me to be able to stress the importance of this topic. The condominium is a form of ownership that can be found in many countries around the world. While this research is specifically about affordable condominiums in Quito and Bogota, I wanted to bring this research to a place like TU Delft, where world-wide problems on the built environment are studied, to emphasize the more general nature of research on this topic across different societies.

I was awarded with the Netherlands Fellowship to pursue my research project in 2011. With this funding, I was not only able to support my PhD research position at OTB during that period, but also fund both my field trips and survey. The fellowship also gave me the opportunity to live in The Netherlands, one of the most beautiful countries in the world, and one where I had always wanted to live because of both its urban and rural landscapes, and especially because of its social housing system whose history is fascinating for an urban planner.

A research project like this one cannot be achieved alone. As a thesis that uses the theory of collective action and that looks at the importance of trust and cooperation for achieving better collective goods, I cannot finish this project without expressing my gratitude to all the different people that believed this is an important phenomenon to research and thanking those that stayed close to me during these years.

I want express my gratitude to NUFFIC for funding my research project, and to thank Veronique van der Vast from the Valorization Center of TU Delft who assisted me by managing the fellowship grant.

Special thanks to my promotors Marja Elsinga and Peter Boelhouwer. Marja, you always provided me with the freedom and trust necessary to develop my research, and gave me the sharpest comments when necessary to keep my research concise and on track.

It has been a pleasure to have an inspiring supervisor like you. To both of you, many thanks for supporting my extra-curricular activities such as with my founding role in A+BE PhD council, while representing the student council at the Research Council of BK, while teaching in Quito, or while I was organizing academic side events. You also supported me when I decided to accept the job at the municipality of Quito when I moved back to Ecuador even though we knew it might delay finishing this thesis.

Thanks to my colleagues of the Housing Systems research group at OTB: Marietta Haffner, Kees Dol, Joris Hoekstra, Harry Boumeester and Harry van der Heijden, for sharing with me interesting conversations about housing market problems in Europe. To my office mates, Christian Lennartz and to Wenjing Deng, thanks for your friendship and support. Thanks to Sylvia Janssen for supervising my survey sample design and analysis. Thanks also to Henny Coolen, and to PhD colleagues Sanne Boschmam and Jaume Tessera who took the time to understand the complexity of the research and gave me key advice about the statistical analysis and the use of STATA.

Thanks to my PhD colleagues and the other researchers at OTB who became my friends during these years: Flavia, Dasa, Sanne, Fanny, Kees, Nurul, Igor, Luz Maria. It is great when it is possible to share life with people that like doing scientific research and to have fun at the same time. I am grateful for having a group of Latin American and Spanish friends; Bea, Daniel, Teo, Hugo, Flavia, Camilo, Toño, you guys became my Delft family. To Isadora Espinosa, Pedro Calle, and Simon, and to Dasa Majcen and Pedro Inacio and Tera, there are not enough words to express how grateful I am to have shared precious moments with you. To my friends in Nijmegen and Delft, especially to my Dutch housemates Carla, Renate and Marloes, I was lucky to find such great friends to introduce me to Dutch life. To Sarah Chebaro, an architect housemate who thought it was fun to draw my condominium case studies for me. And to my Ecuadorian friends, Vanessa Rodriguez and Adrian Jaramillo, I was lucky to have you around and close by during those times.

In Quito and Bogota, I would like to thank all the residents that allowed me to enter into their common properties, and to the presidents or managers of the buildings. Their insights on problems with managing their common property helped me when defining the research design and planning the comparative research. Also, there are many other actors that I would like to thank, and I am sure it is not possible to name them all. In Quito thanks to Jenny Diaz, Alexandra Mina, Alexandra Jaramillo, Silvana Ruiz, Lucia Ruiz, Eduardo Castro, Maria Elena Acosta, Pablo Valencia, Mario Burbano de Lara and to colleagues at FLACSO, Marco Cordova and Ramiro Rojas, who permitted me hold the focus group event at FLACSO in Quito, and to all that came and participated and volunteered in the workshop. In Bogota thanks to Alejandro Florian, Germán Molano, Laura Salamanca, Jorge Enrique Torres and Elizabeth Perez, Alejandro Peláez, Valentina

Peláez, to Delly Betin Aguas, Monica Aldana, Sergio Ballen, Juan Yunda, Ricardo Ortiz, Carolina Pardo. To Maria Mercedes Maldonado, who permitted me to hold the focus group event at the Secretaría de Habitat auditorium. To my host family in Bogota, my friend Lorena Avella, her mother Lilia and the rest of the family, thank you all!

After discovering that Bogota had interesting arrangements in which social managers work with social housing projects, I invited some of these professionals to come to Quito in January of 2013, to meet their Ecuadorian counterparts doing social management, or *acompañamiento social* as it called in Latin America. Together with Fundación Bien Estar, one of the few organizations with experience in condominium social management in Ecuador, we organized an event which people from both the Municipality and the Housing Ministry attended. We shared the different approaches to social management from the two countries. Thanks to Mutualista Pichincha and their directive board, to Pablo Valencia for organizing this event together with me. Thanks to Laura Salamanca and Pilar Leguísamo from Responder Corporation for coming to Ecuador to share their extensive experience helping communities to self-organize and take responsibility of their common property.

My oldest friends know about the ups and downs during all these years. To my friends Maria Augusta Almeida, Paola Silva, Nathalie Alvarez, Cristina Pazmiño, Sofia Valdiviezo, Carolina Proaño, and Jonathan Villacis, thank you all for keeping me close to you even though I have been abroad for too long and missed so many life-events with you and your families.

Many thanks to my coworkers and friends at Municipality of Quito, and to Jacobo Herdoiza, a friend and colleague that believed in my PhD project from the starting point; thank you for always supporting my academic activities and perspectives in housing policy and urban development.

And last but not least, I am grateful of my family who accepted my life abroad and kept me always connected to my country. Thanks to Lucila, Teo, Nino, Patriciño, Juancar, Mom and Dad for always being there supporting both my academic and travel ambitions. I love my country but I love living abroad too. Thanks to technology I was able to remain as close as possible to you. And to Simeon, my love and life partner who patiently encouraged me to finish the thesis as we welcomed a new member to our family. Emilio, you became my true inspiration to send the final draft of this thesis before your arrival; I love you.

Contents

List of Tables	14
List of Figures	16
Summary	17
Samenvatting	25

Part I

1	Introduction to affordable condominium housing	35
1.1	The research problem: Housing policy and deteriorated units	36
1.2	Research approach	40
1.3	Thesis outline	45
2	Conceptual approach	49
2.1	Comparative housing research	50
2.2	Condominium: Individual and common property	62
2.3	Housing institutions as collective action	79
3	Research design and methods	83
3.1	Introduction	83
3.2	Collection of policy and housing market data	86
3.3	Comparative analysis of condominium property laws	89
3.4	Focus groups	90
3.5	Case-study selection	94
3.6	Quantitative survey	101
3.7	Mixed-method approach	106

Part II

4	Housing market and affordable housing policy	111
4.1	Introduction	111
4.2	Housing policy in historical perspective in Colombia and Ecuador	112
4.3	Housing market in Bogota, Colombia	120
4.4	Housing market in Quito, Ecuador	126
4.5	Comparative perspective	132
5	The formal institution: The horizontal property law	135
5.1	Introduction	135
5.2	Studies on condominium regulation	137
5.3	Agents in the condominium regime	142
5.4	Structure of the Horizontal Property Law	149
5.5	Conclusion	167

Part III

6	Professionals in provision of affordable condominiums	171
6.1	Introduction	171
6.2	Literature on network governance	173
6.3	Composition of the low-income condominium policy network	175
6.4	Characteristics of the policy network	184
6.5	Perception of maintenance problems	196
6.6	Conclusion	207
7	Maintenance arrangements in condominium tenure: The household perspective	213
7.1	IAD framework applied to affordable condominium maintenance problems	215
7.2	Dependent variable: Perceived maintenance level (PML)	215
7.3	Independent variables: Elements of the action-situation	217
7.4	Multivariate Regression Model for Bogota and Quito	225
7.5	Comparison of results	229
7.6	Conclusion	232

8 Conclusion: The balance between property law and self-organization 235

- 8.1 Introduction 235
- 8.2 Results 236
- 8.3 Discussion 246
- 8.4 Future research and data collection 248

Appendix

- Appendix A List of interviewees in Bogota and Quito 253
- Appendix B Survey Questionnaire 257
- Appendix C Case studies in Bogota and Quito 265

- References 287
- Curriculum vitae 295

List of Tables

1.1	Thesis outline	48	5.2	Three levels of rules in the action situation (source: Ostrom et al., 2006:46)	141
2.1	Bundle of rights in common property resources (Source: Ostrom, 1992:250-251)	64	5.3	Legal environment of organizations' Integrative Model (source: Edelman & Suchman, 1997)	142
2.2	Bundle of rights in condominiums associated with positions (source: adapted from Ostrom (2003:251))	65	5.4	Actors classified by position: external or internal to condominium property (source: comparative analysis of the law)	147
2.3	Cluster of variables explaining actors' behaviors (source: Ostrom et al., 2006:33)	77	5.5	Formal institutions and institutional arrangements in Colombia and Ecuador	148
3.1	Research design	84	5.6	Majority rule required in assembly meetings in Colombia	155
3.2	Actors and governance levels of governance of low-income condominium policy network (source: Analysis of horizontal property law, empirical research)	91	5.7	Majority rule required in assembly meetings in Ecuador	163
3.3	Methodology for the systematic analysis of the focus groups' second activity and posters	93	6.1	Actors involved in the policy network in Bogota and Quito	176
3.4	Controlled variables for case study selection	96	6.2	Social management organizations, Bogota and Quito. (author, based on fieldwork)	181
3.5	Surveyed nested sample of households in Bogota and Quito	102	6.3	Actors' goals in policy network in Bogota and Quito	187
3.6	Three main common property elements and the selected	104	6.4	Actors' resources in policy network in Bogota and Quito	189
4.1	System of housing incentives for low-income homeownership	119	6.5	Bogota - problems identified in production phase	199
4.2	Subsidy levels by income range in Colombia (elaborated by the author, based on information available at the Welfare Family Agencies, website.)	124	6.6	Quito - problems identified in production phase	199
4.3	Subsidy policy for new dwellings in Ecuador (source: http://www.habitatyvivienda.gob. ec/)	131	6.7	Bogota - problems identified in exchange phase	200
5.1	Seven types of rules that may affect the structure of the situation (source: Ostrom et al., 2006:42)	141	6.8	Quito - problems identified in exchange phase	200
			6.9	Bogota - problems identified in consumption phase	202
			6.10	Quito - problems identified in consumption phase	202

6.11	Proposed solutions in Bogota	203
6.12	Proposed solutions in Quito	204
7.1	Common property elements in Perceived Maintenance Level (PML)	216
7.2	Descriptive statistics of the Perceived Maintenance Level (PML) by case study	216
7.3	Blocks of variables associated with the perceived maintenance outcome (<i>based on Ostrom (2007) and Poteete et al. (2010) for condominium maintenance arrangements</i>)	217
7.4	Community characteristics variables	218
7.5	Socio-economic characteristics of surveyed households in Bogota and Quito	219
7.6	Institutions and governance variables	221
7.7	Resource physical characteristics variables	223
7.8	Variables tested for significant bivariate relationship with PML, for Bogota and Quito separately	224
7.9	OLS nested model for Bogota	226
7.10	OLS nested model for Quito	228
7.11	Comparison of variables associated with PML in Bogota and Quito	229

List of Figures

- 1.1 Mid-rise buildings built in 2010-2012 in Bogota, Colombia. (*Photo credit: Rosa E. Donoso*) 36
- 2.1 A framework for institutional analysis (*adapted from Ostrom 2005:15. source: Poteete, Jansen, and Ostrom, 2010:41*). 77
- 2.2 Conceptual framework to study affordable condominium deterioration levels. Based on Ostrom (1990)(*source: Poteete, Jansen, and Ostrom, 2010:41*). 78
- 2.3 Institutional levels in condominium tenure 80
- 3.1 Selection of case studies in Quito (Q01-Q04) and Bogota (B01-B4) 95
- 4.1 Bogota: percentage of occupied housing units by tenure 1964-2014 (*sources: Data from Census by DANE (Censo de poblacion y vivienda); data for 2007 estimated by CENAC; data for 2014 by ECV Survey (Colombia)*). 121
- 4.2 Bogota: percentage of housing units by type 1973-2005 (*source: Census, DANE*) 122
- 4.3 Bogota's housing stock: percentage of housing units under condominium regime 1964-2005 (*sources: Census Data (Dane) and Cadastre Bogota, July 2011*) 123
- 4.4 Allocated subsidies in Colombia 1991-2009 (*source: Ministry of Environment, Housing and Regional Development (in: Arbelaez et al, 2011)*) 125
- 4.5 Quito: percentage of occupied housing units by tenure 1962-2010 (*sources: INEC varios years*) 127
- 4.6 Quito: percentage of housing units by type (1962-2010)(*source: Data from Census INEC (Censo de poblacion y vivienda)*). Elaborated by the author. 128
- 4.7 Quito's housing stock: percentage of housing units in condominium regime 1962-2010 130
- 4.8 Subsidy allocation for new dwellings from its start in 1999 until 2012 in Ecuador (*source: Housing Ministry (MIDUVI, 2012), provided for this research. Elaborated by the author*) 132
- 6.1 Actors and interdependency (*source: Focus groups results, empirical research, 2012*) 193
- 6.2 Focus group – Quito (*Photo credit: R.E.Donoso*) 198

Summary

Introduction

Both the general public and policy makers see home ownership as a major life goal. Owning a home is a form of capital that creates a social safety net (Elsinga, 2005; Moser, 2009). Home ownership can also help boost self-esteem and contribute to housing satisfaction (Elsinga & Hoekstra, 2005; Marcuse, 1972). In South America, owning your own home is a way to ensure basic economic security and is a dream shared by everyone. For this reason, large-scale investments are needed in owner-occupied homes for low-income buyers. A different light is shed on this dream however when it becomes clear that the quality of subsidized property for low-income groups is subpar due to poor maintenance and buildings quickly deteriorate. This occurs in Chile, Mexico, Brazil, Colombia and Ecuador (Paquette-Vasalli & Sanchez, 2009; Rodriguez & Sugranyes, 2005; Rojas, 2010).

Most studies into housing quality and poor maintenance have been conducted among single-family homes owned by individuals. In South America, especially in cities, low-income homes are usually apartments. This means ownership is shared with other building residents. Most maintenance-related issues occur in joint ownership properties and there is little literature available on this topic.

The aim of this study is to gain more insight into how homeowner's associations work in low-income owner-occupied apartments. When parts of the residential buildings such as the ground on which they are built and the infrastructure are joint property, then a homeowner's association is necessary to keep maintenance of the common property parts. The lack of maintenance of these communal areas is a problem of increasing proportions, which has prompted this research. Which factors play a decisive role in how homeowner's associations function and how building maintenance is organized, how important is the horizontal property law and how does this affect low-income housing policy in Colombia and Ecuador?

This PhD dissertation consists of three components: Part 1 presents the research question, the theoretical framework and the research methods. Part 2 discusses the formal institutions (the rules of the game) involved: housing policy and the property law. Part 3 discusses the informal rules which include the cooperation between professionals and the interaction with residents (the play of the game). The summary includes conclusions and implications for follow-up research and policy.

Theory and research methods

Comparative housing research can serve multiple purposes; for example to evaluate policy and perhaps implement policy that has been successful in other countries. This dissertation is based on a comparative study of two countries and uses the “middle range approach” as discussed in Haffner et al. (2010). With this approach, the assumption is that institutional differences between countries are of crucial importance, but that a comparison is worthwhile and may prove beneficial. This dissertation has a comparative structure that takes institutional differences that are important to home ownership of low-income families into account (Elsinga, 1998; Oxley, 2001; Ruonavaara, 1993; Stephens, 2011). The central hypothesis is that the design of the horizontal property law is of great importance to the effectiveness of homeowner’s associations and maintenance levels of buildings and homes. A comparison of Colombia and Ecuador, neighboring countries with similar housing systems and cultures but different horizontal property law, is a good way to test this hypothesis.

The horizontal property law or law for condominium form of ownership is a formal institution. Formal institutions, together with the informal institutions such as values, determine the rules of the game for actors. (North, 1994:360). This institutional approach is beneficial to studying the functioning of homeowner’s associations. In the further elaboration of the research framework, Ostrom’s (1990, 2005) institutional analysis and development framework (IAD) was used as a starting point.

The Institutional Analysis & Development (IAD) framework makes it possible to analyze the actions in a complex situation and to map the multiple positions of actors. The IAD framework distinguishes three groups of important factors: characteristics of the community, the rules used and the physical characteristics of the common property (Ostrom, 1990, 2005). An important assumption is that actors are not necessarily selfish and rational. Another assumption is that people are not by definition

helpless and unable to work together. The Ostrom approach provides researchers with a framework for mapping out the potential contributions of a community. This framework provides good leads for the analysis of the central problem in this dissertation: poor maintenance in collective homeownership.

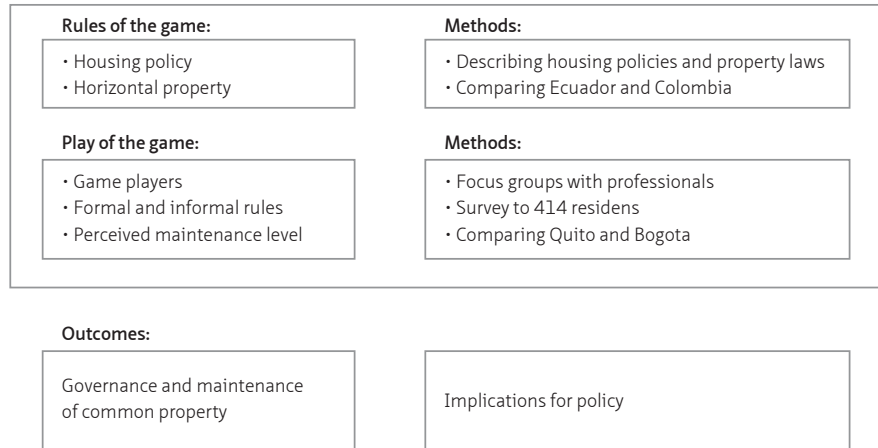


Figure 1. Comparative institutional approach

Figure 1 explains the comparative institutional approach. The first part of the analysis focuses on the formal institutions: the housing policy and horizontal property law (Rules of the game). Policy documents and available statistics were studied in the analysis of housing policy. Subsequently, the property law in Colombia and Ecuador were subjected to a thorough analysis of the law. The focus was on the regulations in the law that support self-government or instead stipulate the role of a professional to be in charge of management and maintenance

A network analysis was then applied to study cooperation among the professionals involved in the provision of low-income housing in condominium. This analysis involved professionals from the municipality, developers, property managers, banks and social workers in Quito and then Bogota. These analyses were conducted using focus groups. The main focus during the discussion was the recognition of the problem of poor maintenance, an analysis of the possible causes and an exploration of possible solutions. The network approach appears to be useful because it shows that there is complexity and a large degree of interdependence among actors.

The analysis of the role of the residents was identified with a survey among 414 residents of 8 different housing complexes with low-income condominium housing. It involved 4 blocks from different construction years in Quito and 4 blocks from different construction years in Bogota. The questionnaire distributed among residents was inspired by Ostrom's IAD framework.

The "mixed method" approach was necessary to map the interaction between formal and informal institutions. This approach is the result of the choice for a "middle range" approach that distills the similarities and differences between two cities/countries with different institutions. The aim is to learn lessons that can lead to improvements in the maintenance in homeowner's associations for low-income households.

"Rules of the game"

In both Bogota and Quito, the majority of households live in owner-occupied dwellings, mostly apartments in condominium. The government housing policy in both countries mainly consists of subsidizing owner-occupied homes for low-income households. The description of the housing policy shows that building homes is a complex affair that requires a great deal of cooperation between parties including local governments, developers, the land registry, funding bodies and the national government as the subsidy provider. Finally it appears that the registration of the policy outcome gives incomplete information for policy evaluation. In practice, homes that are built are registered as single units when they are actually part of housing complex in condominium.

The horizontal property law plays a key role in how homeowner's associations function. The law defines which actors are responsible for the management and maintenance of the shared property. Research has revealed that there are key differences between the laws in the two countries. In Colombia the law stipulates that the first assembly meeting of the homeowner's association must be called by the builder. In Ostrom's words: Colombia has embedded a collective choice-rule in a constitutional one. This concerns a clear and unambiguous anchoring of the body most important to how a homeowner's association functions. In Ecuador, the law does not provide a definitive answer on when a homeowner's association should be established. In practice, it turns out that it's usually up to the project developer to make this decision. Another important difference between the two laws is the responsibility for the management of the homeowner's association. In Colombia, the law stipulates that this must be

organized by a professional and paid manager of the homeowner's association, whereas the law in Ecuador is more flexible and it allows for the position to be filled by a volunteer or paid position if the association can afford it.

“Play of the game”

In both Bogota and in Quito, professionals have indicated that in the realization of owner-occupied apartments for low-income families, they depend on the local government and funding bodies. In both cities a link was found between maintenance issues related to homeowner's associations and the contents of the horizontal property law specifically lack of clarity about the rights and obligations of the joint owners. The law is not clear to everyone and not everyone is aware of the law. The analysis shows that all participants acknowledge the problem, can identify various causes and agree that it is unclear who the responsible party or problem owner is.

For Bogota, research showed that overdue maintenance problems are usually due to poor management decisions by the professional responsible for the homeowner's association. Research in Quito yields other explanations: a lack of community spirit, lack of respect for rules and standards and different ideas about the use of common spaces. From this it can be concluded that there is a connection between how homeowner's associations in Bogota and Quito function and the property laws in Colombia and Ecuador. In the words of Ostrom: “the activities and policies of external political regimes can affect the level and type of self-organization to achieve collective benefits” (Ostrom, 1990: 190). The professionals recognize and emphasize that their role and interpretation affects how homeowner's associations function in the long term.

The perception and opinion of the residents about maintenance problems was mapped out on the basis of a survey that was carried out in 2014. The survey included questions about the composition and characteristics of the households, their awareness of their position in the homeowner's association, their behavior and their relationship with the condominium regulations. The results are in line with Ostrom's framework. It appears that: (1) trust in leaders of the community, (2) agreement about who is responsible for maintenance, (3) participation in assembly meetings, and (4) adequate physical conditions of the building, are conditions for adequate maintenance outcomes. Owners collectively need information, as well as knowledge about rules, to be able to manage the condominium.

Conclusions

The results show that legal obligations can have a counterproductive effect on the involvement and self-organization of homeowners. The property law in Colombia stipulates that a professional administrator must be appointed to manage the homeowner's association. The result is that residents feel less personal responsibility and attend fewer meetings of the homeowner's association.

In Ecuador, the rules for maintenance are much more flexible and the chairman of the homeowner's association can assume the role of manager. As a result, the residents appear to be more involved in the homeowner's association's decision-making processes, but are generally less satisfied with the outcome.

The horizontal property law plays a key role in achieving better maintenance results in Bogota. The project developer is responsible for ensuring the legal requirement to appoint a professional homeowner's association administrator. The law stipulates that a maintenance plan must be drawn up before building materials in the residences start showing signs of deterioration. A maintenance plan and a detailed payment plan for contributions to the homeowner's association must be ready by the time the homes are completed and residents move in. This is in line with Ostrom's IAD framework, when she says that when rules of the game are known, specifically the benefits and costs, the outcomes are more satisfactory (Ostrom, 1990).

Most studies into maintenance by homeowner's associations research the relationship between maintenance and the characteristics of households and homes (Orban, 2006; Alterman, 2010; Hastings et al., 2006). This study also included these variables in addition to the formal rules and the ability to self-organize in homeowner's associations. By using the IAD framework, it became possible to investigate the interaction between formal and informal institutions (play of the game). A comparison of the "play of the game" in Bogota and Quito allowed for conclusions to be drawn about the influence of the differences in both countries' property laws.

Uncovering the relationship between the horizontal property law and its effect on the functioning of a homeowner's association through a combination of quantitative and qualitative research is an added value of this research. The significance of these outcomes goes beyond Bogota and Quito and contributes to insight into mechanisms in the functioning of home owner's associations in general (Bengtsson & Hertting, 2014).

Implications for future research

This research provides input for the research questions of the future. A first follow-up line of inquiry is the impact of the functioning of homeowner's associations and the maintenance results on the increasing value of homes. Further studies are required into the functioning of the owner-occupied apartment market and specifically the role of collectivity in housing preferences, how maintenance fees are set and how the organization of a homeowner's association influences the value of apartments.

Dilapidated homes have a major impact on the quality of life in neighborhoods. Urbanization, densification and promoting homeownership go hand in hand. The share of owner-occupied apartments is raising rapidly and with it the risk of poorly functioning homeowner's associations. The management of collective homeownership is part of the research agenda of sustainable, resilient and smart cities.

This dissertation presents a framework for international comparative research into the functioning of homeowner's associations. Insight into the interaction between formal and informal institutions is crucial in a world in which citizens have to take personal responsibility, governments have ambitious goals and quality of housing and life is at risk.

This dissertation shows that the number of homeowners' associations is greater than official records indicate. There is room for improvement when it comes to the registration of property because this is essential to good housing policy implementation and evaluation.

Policy implications

As cities grow, densification and the continued construction of apartment buildings require policy for owner-occupied apartments that is featured prominently in housing policy. Poor maintenance of common property parts is a collective issue that has major implications for the quality of life in urban areas and the asset of individual homeowners. National policy for the construction of subsidized owner-occupied homes must be accompanied by local policies for the proper management of homeowner's associations.

The quality and sustainability of low-income housing should be part of housing policy monitoring and evaluation. Shared spaces and common land with facilities deserve special attention. The joint ownership of land and facilities can also be a source of income and joy.

Climate change has implications for the quality and sustainability requirements of homes, which will inevitably lead to large-scale renovations. Renovation requires collective decision-making for façades and other parts of the building that are viewed as the collective property of the homeowner's association. The availability of funding options is also extremely important for these types of renovations and this is a responsibility for the government and for profit and non-profit financial institutions to facilitate access to financing that can be paid off by the homeowner's association.

Natural disasters such as earthquakes occur frequently in Bogota and Quito. Joint ownership requires joint insurance for earthquake damage. The 2016 Quito earthquake may serve as a wake-up call in this respect. If there are collective action dilemmas and apartment buildings do not comply with the law regarding the obligatory requirement to have insurance for all kinds of damages, the government can play a role in overcoming these dilemmas by offering guarantees. Policy for condominium ownership in growing cities is essential to creating resilient cities.

The old adage 'my home is my castle' is in dire need of adaptation in the case of condominiums, as "our castle" would be more appropriate here.

Samenvatting

Introductie

Een eigen huis wordt zowel door veel huishoudens als door beleidsmakers gezien als cruciaal. Een eigen huis is een vorm van vermogen en daarmee een sociaal vangnet (Elsinga, 2005; Moser, 2009), bovendien kan het bijdragen aan de eigenwaarde en tevredenheid met de woonsituatie (Elsinga & Hoekstra, 2005; Marcuse, 1972). In Latijns America wordt de eigen woning beschouwd als basiszekerheid en droom voor een ieder. Er wordt daarom op grote schaal en voor grote bedragen geïnvesteerd in koopwoningen voor mensen met een laag inkomen. Deze droom komt echter in een ander daglicht te staan als blijkt dat gesubsidieerde koopappartementen voor lage inkomensgroepen snel verloederen door slecht onderhoud zoals blijkt in Chili, Mexico, Brazilië en ook Colombia en Ecuador (Paquette-Vasalli & Sanchez, 2009; Rodriguez & Sugranyes, 2005; Rojas, 2010).

Het meeste onderzoek naar woningkwaliteit en gebrekkig onderhoud van woningen is uitgevoerd onder huishoudens die individueel eigenaar zijn van een woning. In Latijns Amerika, met name de grote steden, zijn woningen voor lage inkomens doorgaans appartementen en dus is er sprake van gezamenlijk eigendom. Juist in dat gemeenschappelijke eigendom komen veel problemen voor en daar is nog weinig onderzoek naar gedaan.

Het doel van dit onderzoek is het verkrijgen van meer inzicht in het functioneren van verenigingen van eigenaren (VVE) bij koopappartementen voor lage inkomens. Bij een VVE zijn delen van woongebouwen zoals de grond en de infrastructuur van het gebouw gezamenlijk eigendom. Het gebrek aan onderhoud van deze gemeenschappelijke woningdelen is een probleem dat steeds grotere vormen aanneemt en vormde daarom aanleiding voor dit proefschrift. Welke factoren spelen een doorslaggevende rol voor het functioneren van VVE's en daarmee voor onderhoud van woningen, hoe belangrijk is de appartementswet en wat betekent dit voor woonbeleid voor lage inkomens in Colombia en Ecuador?

Het proefschrift bestaat uit drie delen. Deel 1 presenteert de onderzoeksvraag, het theoretisch raamwerk en de onderzoeksmethoden. Deel 2 gaat in op de formele instituties (the rules of the game) die van belang zijn: woonbeleid en appartementsrecht. Deel 3 gaat in op de informele instituties: de samenwerking tussen professionals en interactie met bewoners (the play of the game). De samenvatting sluit af met de conclusies en implicaties voor vervolgonderzoek en beleid.

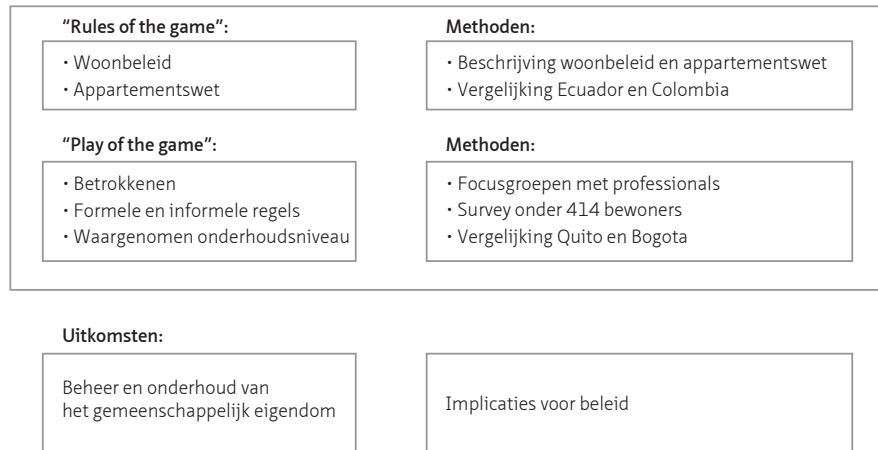
Theorie en onderzoeksmethoden

Vergelijkend woononderzoek kan verschillende doelen dienen; bijvoorbeeld om beleid te evalueren en eventueel om succesvol beleid in het ene land te implementeren in een ander land. Dit proefschrift kiest voor een vergelijking van twee landen en hanteert de zogenaamde “middle range approach” (Haffner et al., 2010). De veronderstelling bij deze benadering is dat institutionele verschillen tussen landen cruciaal zijn, maar dat een vergelijking de moeite waard is. Dit proefschrift kent een vergelijkende opzet die rekening houdt met de institutionele verschillen die van belang zijn bij eigen woningbezit voor lage inkomens (Elsinga, 1998; Oxley, 2001; Ruonavaara, 1993; Stephens, 2011). De centrale hypothese is dat de inrichting van de appartementswet van groot belang is voor het functioneren van verenigingen eigenaren en daarmee op het onderhoudsniveau van de woningen. Een vergelijking van Colombia en Ecuador, buurlanden met vergelijkbare huisvestingssystemen en cultuur, maar verschillende appartementswetten is een goede manier om deze hypothese te testen.

De appartementswet is een formele institutie. Formele instituties bepalen samen met de informele instituties zoals normen, waarden en codes, de regels van het spel voor actoren. (North, 1994:360). Deze institutionele benadering blijkt vruchtbaar voor het bestuderen van het functioneren van verenigingen van eigenaren. Bij het verder uitwerken van het onderzoekskader werd het institutionele raamwerk van Ostrom (1990, 2005) als vertrekpunt genomen.

Het Institutional Analysis & Development (IAD) raamwerk maakt het mogelijk om de acties in een complexe situatie te analyseren en de meervoudige posities van actoren in kaart te brengen. Het AID raamwerk maakt daarbij onderscheid in drie groepen van belangrijke factoren: kenmerken van de community, de gehanteerde regels en de fysieke kenmerken (Ostrom, 1990, 2005). Een belangrijke aanname is dat actoren niet per definitie egoïstisch en rationeel zijn. Een andere aanname is dat mensen niet per definitie hulpeloos zijn en niet in staat om samen te werken. De benadering van

Ostrom geeft onderzoekers een kader om de potentiële bijdrage van de community in kaart te brengen. Dit raamwerk biedt goede aanknopingspunten voor de analyse van het centrale probleem in dit proefschrift: gebrekkig onderhoud bij collectief woningbezit.



Figuur 1. Comparatieve institutionele benadering

In figuur 1 wordt de comparative institutionele benadering uitgewerkt. Het eerste deel van de analyse focust op de formele instituties: het woonbeleid en de appartementswet. Bij de analyse van het woonbeleid werden beleidsdocumenten en beschikbare statistieken bestudeerd. Vervolgens zijn de appartementswetten in de Colombia en Ecuador aan een grondige wetsanalyse onderworpen. Hierbij werd met name gefocussed op de voorschriften in appartementswetten zijn die zelfbestuur ondersteunen of juist de rol van een professional voorschrijven.

Vervolgens is een netwerkanalyse toegepast op de samenwerking tussen de betrokken professionals. Het ging om professionals bij de gemeente, bij ontwikkelaars, vastgoedbeheerders, banken en sociaal werkers in Quito en daarna in Bogota. Deze analyses zijn uitgevoerd in een focusgroep setting. Centraal hierbij stond de herkenning van het probleem gebrekkig onderhoud, een analyse van de oorzaken en een verkenning van mogelijke oplossingen. De netwerkbenadering blijkt nuttig omdat daarmee duidelijk werd dat er sprake is van complexiteit en grote onderlinge afhankelijkheid.

De analyse van de rol van de bewoners werd in beeld gebracht met een enquête onder 414 bewoners van 8 verschillende wooncomplexen met koopwoningen voor lage inkomens. Het ging om 4 woningcomplexen uit verschillende bouwjaren in Quito en 4 complexen uit verschillende bouwjaren in Bogota. De vragenlijst die verspreid werd onder bewoners, was geïnspireerd op het IAD-raamwerk van Ostrom.

De “mixed method” benadering was noodzakelijk om de interactie tussen formele en informele instituties in kaart te brengen. Deze aanpak vloeit voort uit de keuze voor een “middle range” benadering waarin overeenkomsten en verschillen tussen twee steden/landen met verschillende instituties worden gedestilleerd. Het doel daarbij is lessen te leren die kunnen leiden tot verbetering van het onderhoud in verenigingen van eigenaren voor lage inkomens.

“Rules of the game”

In zowel Bogota als Quito heeft het merendeel van de huishoudens een koophuis en in veel gevallen gaat het om een appartement. Het woonbeleid van de overheden in beide landen bestaat vooral uit het subsidiëren van koopwoningen voor lage inkomens. De beschrijving van het woonbeleid laat zien dat het realiseren van de woningen een complexe aangelegenheid is die samenwerking vergt van vele partijen zoals lokale overheid, ontwikkelaars, kadaster, financiers en de landelijke overheid als subsidieverstrekker. Ten slotte blijkt dat de registratie een probleem is: woningen die geregistreerd staan als individueel eigendom, blijken in de praktijk deel uit te maken van verenigingen van eigenaren.

De appartementswet speelt een belangrijke rol in het functioneren van verenigingen van eigenaren. De wet omschrijft welke actoren verantwoordelijk zijn voor beheer en onderhoud van het gemeenschappelijk eigendom. Er blijkt sprake van cruciale verschillen tussen de wetten in de twee landen. In Colombia schrijft de wet voor wanneer een vereniging van eigenaren in het leven moet worden geroepen. In woorden van Ostrom: Colombia heeft een collectieve keuze regel ingebed in een grondrechtelijke. Het gaat om een heldere en duidelijke verankering van het belangrijkste orgaan voor het functioneren van een VVE. In Ecuador geeft de wet geen uitsluitel over wanneer precies een VVE in het leven moet worden geroepen. In de praktijk blijkt het aan de projectontwikkelaar om te beslissen wanneer een vve wordt opgericht. Een ander belangrijk verschil tussen de twee wetten is de verantwoordelijkheid voor het beheer van de VVE. In Colombia is wettelijk geregeld dat

dit moet worden uitgevoerd door een professionele betaalde VVE beheerder, terwijl de wet in Ecuador ruimte laat voor invulling door een vrijwilliger.

“Play of the game”

In zowel Bogota als in Quito gaven professionals aan dat zij bij het realiseren van koopappartementen voor lage inkomens afhankelijk zijn van de gemeenten en van financiers. In beide steden werd de link gelegd tussen problemen met het onderhoud bij vereniging van eigenaren en de inhoud van de appartementswet, met name onduidelijkheid over de rechten en plichten van de gezamenlijke eigenaren. De wet is niet voor iedereen duidelijk en ook niet bij iedereen bekend. De analyse maakte duidelijk dat alle participanten het probleem herkennen, verschillende oorzaken zien en het er over eens zijn dat het niet duidelijk is wie de eigenaar is van het probleem.

In Bogota kwam naar voren dat het probleem van achterstallig onderhoud vooral is te wijten aan slecht management van professionele VVE beheerders. In Quito komen andere verklaringen naar voren: gebrek aan gemeenschapszin, gebrek aan respect voor regels en normen en verschillende ideeën over het gebruik van gemeenschappelijke ruimten. Hieruit kan de conclusie worden getrokken dat er een verband bestaat tussen het functioneren van VVEs in Bogota en Quito en de appartementswetten in Colombia en Ecuador. In de woorden van Ostrom: “The activities and policies of external political regimes can affect the level and type of self-organization to achieve collective benefits” (Ostrom, 1990: 190). De professionals herkennen en benadrukken dat hun rol en invulling daarvan effect heeft op het latere functioneren van verenigingen van eigenaren.

De perceptie en mening van de bewoners over het onderhoud werd in kaart gebracht aan de hand van een enquête die in 2014 werd uitgevoerd. In de enquête werd gevraagd naar de kenmerken van de huishoudens, hun kennis van hun positie in de vereniging van eigenaren, hun gedrag en hun analyse van de problemen. De uitkomsten zijn in lijn met Ostroms IAD framework: Wanneer er sprake is van 1) vertrouwen in de leiders van de community, 2) overeenstemming over de verantwoordelijkheid voor onderhoud, 3) deelname aan de VVE vergaderingen 4) een adequate fysieke conditie, blijken voorwaarden voor een positieve evaluatie van de onderhoudssituatie. Voor het adequaat functioneren van een VVE is het noodzakelijk dat bewoners kennis hebben van de onderhoudssituatie en -planning en van de regels.

Conclusies

De resultaten laten zien dat wettelijke verplichtingen een contraproductief effect kunnen hebben op de betrokkenheid en zelforganisatie van eigenaren. De appartementswet in Colombia schrijft voor dat er een professionele VVE-beheerder moet worden aangesteld, dit leidde tot minder verantwoordelijkheidsgevoel bij bewoners en beperkte deelname aan vergaderingen van de VVE.

In Ecuador zijn de regels voor onderhoud veel flexibeler en kan de voorzitter van de VVE de rol van beheerder op zich nemen. De bewoners blijken daardoor meer betrokken bij de besluitvorming in de VVE, echter ze zijn minder tevreden met de uitkomst.

De appartementswet speelt een belangrijke rol in het realiseren van beter onderhoudsresultaten in Bogota. De wettelijke verplichting tot een professionele VVE-beheerder wordt uitgevoerd door de projectontwikkelaar als eerste eigenaar. De wet schrijft voor dat er een onderhoudsplan is voordat de materialen in de woningen verslechtering vertonen. Dus als de woningen worden overgedragen aan de bewoners ligt er een onderhoudsplan en is ook helder wat de eigenaren moeten betalen aan de VVE. Dit is in overeenstemming met het IAD raamwerk van Ostrom: “when the rules of the game are known, specifically the benefits and costs, the outcomes are more satisfactory” (Ostrom, 1990).

De meeste studies naar onderhoud van VVEs onderzoeken de relatie tussen onderhoud en de kenmerken van huishoudens en woningen (Orban, 2006; Alterman, 2010; Hastings et al., 2006). Ook in dit onderzoek zijn deze variabelen betrokken, maar daarnaast zijn ook de formele regels en de zelforganisatie in het onderzoek betrokken. Door gebruik van het IAD raamwerk werd het mogelijk de interactie tussen formele en informele instituties (“play of the game”) te onderzoeken. Door een vergelijking van de “play of the game” in Bogota en Quito konden conclusies worden getrokken over de invloed van de verschillen in de appartementswetten tussen de twee landen.

Het analyseren van de relatie tussen de appartementswet en het effect daarvan op het functioneren van een VVE door middel van combinaties van kwantitatief en kwalitatief onderzoek is een meerwaarde van dit onderzoek. De betekenis van deze uitkomsten gaat verder dan Bogota en Quito en draagt bij aan inzicht in mechanismes bij het functioneren van VVEs in het algemeen (Bengtsson & Hertting, 2014).

Implicatie voor toekomstig onderzoek

Dit onderzoek geeft stof tot onderzoeksvragen voor de toekomst. Een eerste vervolgvraag is de impact van het functioneren van VVEs en de onderhoudsuitkomsten op de waardeontwikkeling van de woningen. Het is belangrijk dat onderzoek wordt gedaan naar het functioneren van de markt voor appartementen en in het bijzonder hoe collectiviteit een rol speelt in de woonvoorkeuren, hoe prijzen voor onderhoud worden bepaald en hoe de organisatie van de VVE van invloed is op de waarde van de appartementen.

Verwaarlozing van woningen heeft een grote impact op de leefbaarheid van buurten. Urbanisatie, verdichting en stimulering van het eigen woningbezit gaan hand in hand. Het aandeel koopappartementen stijgt snel en daarmee ook het risico op slecht functionerende verenigingen van eigenaren. Het beheer van collectief woningeigendom hoort op de onderzoeksagenda van duurzame, veerkrachtige en slimme steden.

Dit proefschrift presenteert een raamwerk voor internationaal vergelijkend onderzoek naar het functioneren van verenigingen van eigenaren. Kennis van de interactie tussen formele en informele instituties is cruciaal in een wereld waarin burgers eigen verantwoordelijkheid moeten nemen, overheden ambitieuze doelen hebben en de leefbaarheid onder druk staat.

Dit proefschrift laat zien dat het aantal verenigingen van eigenaren groter is dan blijkt uit de officiële registratie. Registratie van eigendom is voor verbetering vatbaar en cruciaal voor goed beleid.

Implicaties voor beleid

Aangezien steden groeien verdichten en steeds meer appartementen bouwen verdient beleid voor koopappartementen een prominente plek in het woonbeleid. Gebrekkig onderhoud van appartementen is een collectief probleem met grote consequenties voor de leefbaarheid van steden en het vermogen van individuele eigenaren. Nationaal beleid voor de productie van gesubsidieerde koopwoningen dient vergezeld te gaan van lokaal beleid voor goed beheer van verenigingen van eigenaren.

De kwaliteit en duurzaamheid van woningen voor lage inkomens zou onderdeel moeten uitmaken van evaluaties van woonbeleid. Hierbij verdienen gemeenschappelijke ruimten, gemeenschappelijke grond met faciliteiten bijzondere aandacht. Het gemeenschappelijk eigendom zeker van grond en faciliteiten kan ook een bron van inkomsten en vreugde zijn.

Klimaatverandering impliceert hogere kwaliteits- en duurzaamheidseisen aan woningen en resulteert in een enorme renovatieopgave. Renovatie vergt even als onderhoud collectieve besluitvorming voor bijvoorbeeld gevels als collectief eigendom van de vereniging. Bovendien is het van groot belang dat er ook financieringsmogelijkheden zijn voor deze renovaties; een zorg van overheid en (non) profit financiële instellingen.

Natuurrampen zoals aardbevingen zijn een bekend fenomeen in Bogota en Quito. Gezamenlijk eigendom vergt een gezamenlijke verzekering voor aardbevingsschade. De aardbeving in Quito in 2016 kan in dat opzicht worden beschouwd als een wake up call. Indien er sprake is van collectieve actie dilemma's, kan de overheid een rol nemen om het dilemma te doorbreken met een garantie. Beleid voor collectief woningeigendom in groeiende steden is cruciaal in het streven naar veerkrachtige steden.

Het aloude adagium 'my home is my castle' is aan aanpassing toe wat betreft koopappartementen, het zou "our castle" moeten zijn.

Part I

Research problem, theories, and methods

The first part of this thesis comprises the introduction, the conceptual approach, the research design, and the research questions and methods.

1 Introduction to affordable condominium housing

Condominium (n) / kəndə'mɪniəm/¹

From Latin com (cun)- "together" + dominum "right of ownership"

The aim of this thesis is to help policymakers better understand why low- and middle-income homeowners have difficulties with the maintenance of common property parts of the buildings they occupy. Homeowners are expected to be in control of their units, but why are some of them not taking care of their properties? What is the problem in the context of Latin American housing policy? Which factors play a distinctive role, and what does this mean for Colombian and Ecuadorian policies on affordable housing?

Low- and middle-income households in Latin America can achieve the dream of homeownership by buying an affordable unit with the assistance of subsidy to make the down-payment. Both subsidization programs and affordable housing provision are regulated by government. The urban property system to which these housing solutions are directed is the condominium regime. By comparing cases from two capital cities of Latin America, namely Bogota, Colombia and Quito, Ecuador, this thesis seeks to unravel the institutional complexity of the policy system and homeownership in condominium.

As cities grow and communities are built in greater density, the meaning of homeownership changes. In an urbanized world, homeownership occurs in multifamily and collective arrangements of land and architecture (Robertson, 2012). That description points to the kind of homeownership that is the focus of this study: low-income families in dwellings in horizontal property. Horizontal property is the term used in property law to refer to the ownership of air space within a collective structure, which is also called condominium (Lujanen, 2010). To gain a better understanding of the maintenance of horizontal property, it is necessary to understand the bundle of rights and the collective action dilemmas existing in a common property such as the condominium. In the context of condominium housing, owning a home of one's own implies a more complex configuration of rights than just the possession of a single unit.

1

Online etymology dictionary. <http://www.etymonline.com/>

§ 1.1 The research problem: Housing policy and deteriorated units



FIGURE 1.1 Mid-rise buildings built in 2010-2012 in Bogota, Colombia. (Photo credit: Rosa E. Donoso)

The picture above illustrates two of the main social housing sectors in Latin America. Ascending towards the top of the hills is a typical informal settlement, where each dwelling was incrementally self-built by their occupants. Whether attached or detached, each household is responsible for their own self-built house. The importance of squatter settlements, their formative processes, and the habitat conditions in this sector have dominated housing policy research in developing countries. However, as cities shift towards more formal and dense housing solutions, other housing conditions and problems come to the fore that warrant observation and study.

Since the mid-twentieth century, Latin America's national governments have built mid-rise apartments for owner-occupation in an effort to address the housing needs of low-income families in cities. Nowadays, under a new policy network, these dwellings continue to be produced but now in conjunction with the private sector. The formal market for affordable housing comprises dwellings that are generally mass-produced

and that have building permits and property titles. The informal market operates outside the bounds of prescribed legal systems and modern urban development patterns. Informal housing includes dwellings that are self-built over time without participation of the construction companies and investors that are typically involved in the formal housing market.

However, apart from the process of housing provision, the key difference between the squatter houses on the hills and the mid-rise buildings pictured above lies in the form of tenure. First of all, self-built houses are owner-occupied dwellings on individual plots of land. In contrast, apartments are individually owned but at the same time are partly common property with respect to both the building and the land. In short, these apartments fall under the condominium regime. Owning a single-family house is very different than owning an apartment or a unit in condominium. In a single-family house the burden of maintenance weighs on the household; in condominium, both the decision-making about and the costs of maintenance are shared with co-owners and other occupants.

'A home of one's own' is perceived by families and policymakers as a fact of life. Homeownership is the preferred form of tenure in housing policies. Over the last few decades the growth of homeownership has been remarkable around the world (Piketty, 2014). From a social policy perspective, homeownership is considered an important economic asset for low-income families (Elsinga, 2005; Moser, 2009), as well as a source of self-esteem and satisfaction (Elsinga & Hoekstra, 2005; Marcuse, 1972). "Owning rather than renting is thought to foster higher levels of perceived control over life events" (Rohe & Basolo, 1997:797). However, other investigators have demonstrated that homeownership is highly affected by location and neighborhoods effects, implying that there are other factors besides the individual control over the dwelling to consider in housing research (Galster, 1987). It is assumed that owner-occupiers will maintain their properties better than tenants or landlords (owner-investors). And likewise, several claims have been made about the benefits of homeownership for low-income families.

Besides the benefits that homeownership presumably bring to low-income families, the literature describes some risks and reveals how certain assumptions about the benefits of homeownership fall short when low-income families become owner-occupiers (Galster, 1983; Littlewood & Munro, 1996). Failure to maintain the dwellings is one effect that may actually create more problems for a low-income family. The literature warns about the potential for a low return on investment and negative equity when the unit deteriorates, which can make homeownership more of a problem than a solution (Scanlon, 1998). Low-income homeowners often neglect the maintenance of their properties for social and economic reasons, but possibly also

because of the poor quality of the structure, which makes maintenance of a dwelling more costly (Galster, 1983; Scanlon, 1998).

Recent studies in Latin American consolidated self-help neighborhoods² have documented a need for better upkeep and housing rehabilitation policies (Ward, Jiménez & Virgilio, 2014).³ Within the formal sector in Chile, Mexico, and Brazil there is evidence that subsidized dwellings in ownership start to deteriorate prematurely, just a few years after the new homeowners move into the dwelling (Paquette-Vasalli & Sanchez, 2009; Rodriguez & Sugranyes, 2005; Rojas, 2010). Similar problems are observed in Colombia and Ecuador, as will be elaborated in this thesis.

Under the right to housing, different housing policies have been applied in Latin American countries. As set forth above, two housing sectors have been targeted by housing policy programs seeking to guarantee that the population lives in adequate homes (UN-HABITAT, 2011). Policies focusing on informal settlements pursue regularization and improvement of facilities in the public domain such as streets and public services. Within the formal sector, government incentives promote the production of new dwellings for affordable ownership (Donoso & Elsinga, 2016; Ferguson & Navarrete, 2003; Zanetta, 2001). The right to an adequate home is not necessarily a right to own a home (Florian, 2012; Rolnik, 2013). However, owning a home is an important social aspiration and a dream providing direction in people's lives (Elsinga & Hoekstra, 2005; Ronald, 2008).

A market-oriented, subsidized mechanism for low-income homeownership was first adopted in Chile in 1977; today the policy is commonplace in Latin America (Ferguson, Rubinstein & Vial, 1996; Gilbert, 2004). It has been adopted as a successful strategy to increase the provision of affordable dwellings and homeownership (Rojas, 2001). However, after more than three decades of implementation some problems have come to light, including the lack of maintenance (Rojas, 2010).

2 I prefer to call them self-help neighborhoods instead of slum areas or informal settlements because most of them today have had urban improvements programs.

3 Rehabilitation is needed in particular in those settlements that are thirty to forty years old, located in the inner-suburban areas of Latin American cities, and currently owned by low- and middle-income families. To read more about this research, see Ward et al., 2014.

Research focusing on housing quality or lack of maintenance, in either formal or informal⁴ situations, is generally focused on individual households owning a single-family house or an individual flat.⁵ In Latin America, particularly in big cities, low-income homeownership exists under multifamily and shared ownership regimes, which implies different institutional arrangements than would pertain to a single-family house. How might our understanding of the deterioration of dwellings change when these are under a condominium regime?

The body of literature about condominiums rarely distinguishes those that are produced and inhabited by lower-income groups, but there are some exceptions (Esquivel, 2008; Rodriguez & Sugranyes, 2005; Werczberger & Ginsberg, 1987). However, since management problems have become more common, housing scholars have started to investigate the challenges of condominium maintenance in different parts of the world. For example, privatization of the state housing stock in Eastern Europe raised awareness of the need to address the repair and management problems that came to light when social housing was converted to condominiums (Grover, Munro-Faure & Solviev, 2002; Orban, 2006; Rabenhorst & Ignatova, 2009; Soaita, 2012).

In the last decade, research coming from Latin America – notably Chile (Rodriguez & Sugranyes, 2005), Mexico (Esquivel, 2008; Paquette-Vasalli & Sanchez, 2009), Colombia (Mejia, 2006), and Brazil (Paz, 2014; Rolnik & Royer, 2014) -- has demonstrated that the lack of maintenance of dwellings built with the help of subsidy policies for low-income homeownership is a common problem in affordable condominium housing. In this context comparisons would yield particularly useful insights, allowing the policymakers to better understand the problems and to find policy solutions. Considering that the subsidy policy approach to low-income homeownership has been transferred to many countries in the Latin American region (Ferguson et al., 1996; Gilbert, 2004), it is surprising that cross-national comparisons have not yet been made to study deterioration in the condominium housing stock of low-income homeowners.

4 Informal housing is a term used within the Latin American research community to refer to the self-help processes of housing provision without building permits and formal registration at the city level. In these settlements land ownership is sometimes legal or in the processes of land titling.

5 The literature of maintenance practices of European social housing is not necessarily similar to the Latin American cases since the institutions and people in charge of maintenance are different.

§ 1.2 Research approach

Buildings under a condominium regime can be considered as communities, albeit 'loose' or hybrid ones, since the institutional structure is prescribed or already defined during the housing provision process (Ball & Harloe, 1992) and established in the property model implied in horizontal property law (Lujanen, 2010; Merwe, van de, 2015; Orban, 2006). Houses in condominiums are private goods, although their main characteristic is the common property of the land, structure, and infrastructure of the buildings. Common property elements need to be maintained collectively. Therefore, this thesis assumes that condominiums can be studied as common property resources (Ostrom, 1990).

The research approach uses Ostrom's Institutional Analysis and Development (IAD) framework. Its starting point is the observation of how rules, governance practices, and physical characteristics of a common property resource influence collective action. Since the 'resource' is the outcome of a housing policy, concretely people's homes, the research approach is aligned with comparative housing research theories as used in housing systems studies (Haffner, Hoekstra, Oxley & van der Heijden, 2010; Oxley, 2001; Toussaint, 2011). By comparing two systems, drawing cases from two countries, it is possible to test whether the law and context, including each network of actors, are significant variables and have an influence on the policy outcome.

The main pillar of affordable condominium housing is a formal institution: the law of horizontal property or condominium law (Blandy & Hunter, 2012; Lujanen, 2010; Orban, 2006). Nonetheless, "as expressed in forms of life, institutions are analysed only in so far as they form a consensual backdrop against which action is negotiated and its meanings formed" (Giddens, 1979:50). Therefore, even though the law is a key variable in this research, the goal of this thesis is to observe how it is interpreted and ascertain whether maintenance practices are actually influenced by laws.

The institutional approach applied in this thesis is explained in more detail in chapter 2. At this point, however, a brief introduction is necessary to frame the scope of the research and its main questions.

Institutions are the underlying rules of the game, as North (1994) explained. Institutions "are made up of formal constraints (e.g. rules, laws, constitutions), informal constraints (e.g. norms of behavior, conventions, self-imposed codes of conduct), and their enforcement characteristics" (North, 1994:360). In affordable condominium housing both formal and informal institutions can be observed, especially where the economic and sociological meanings of housing and communities

merge (Ostrom, 1990; Ronald, 2005; Toussaint, 2011). This thesis is about people's homes and their collective maintenance practices, so the meanings of housing institutions are of particular importance (Bengtsson & Ruonavaara, 2011; Elsinga, 1998; Ronald, 2008; Ronald & Hirayama, 2006).

The notion of governance often "emphasizes that policies are formulated and implemented in multi-actor, networked environments, in which actors pursue different goals" (Rhodes, 1997 in Bueren & Heuvelhof, 2005:47). Governance is about the cooperative process, "about organizing, about running organizations, about steering" (Bortel, van, 2012:93). Governance occurs in horizontal arenas of policymaking, where public, private, and self-governed actors contribute to the formation of the different governance arrangements that are generally involved in the production and implementation of public policy (Sørensen & Torfing, 2007).

Governance of the condominium occurs in different but coexisting arenas, such as during the production of condominium housing, and afterwards when homeowners move into the new dwellings and live there as co-owners. The main assumption of this thesis is that condominium property law brings structure to the governance arrangements that are necessary to produce, own, and live in condominium property. Actors involved in housing provision, including the professionals, are regulated by this law; it also stipulates the homeowners' rights and obligations. As explained by the theory of governance and institutions, formal institutions bring some order into chaos, but "they do not determine the course and outcomes of the game" (Bueren & Heuvelhof, 2005:48). Moreover, in comparative housing research, not only formal but also informal institutions matter when observing housing systems' structures and outcomes (Toussaint, 2011; Heijden, van der, 2013).

The main outcome under scrutiny here is the maintenance level of condominium housing. There are several factors that may influence the perception of maintenance levels, and this thesis makes a diagnosis of these factors, as set forth in Ostrom's IAD framework. Two types of factors are subjected to analysis. First, this thesis evaluates the opinions and positions of the policymakers and professionals involved in the production of affordable housing in condominium. And second, this thesis considers the factors or variables that take into account the characteristics of the community of homeowners, their perceptions regarding the rule of law, and their opinions about the physical characteristics of the resource. Chapter 6 deals with the governance of both policy actors and housing development processes as they are perceived by the professionals involved in the provision process. Then, chapter 7 deals with the characteristics of low- and middle-income owners in condominium.

To what extent do both formal and informal institutions affect the maintenance outcome? This thesis advances the comparative housing approach by bringing Ostrom's (1990) scholarly position to bear on the role of the institutions in the condominium tenure. Condominium tenure is a form of co-ownership with ancient institutional roots but taking specific forms in different parts of the world. In Latin America, modern condominium laws regulate individual and collective rights and obligations and also regulate the homeowners associations (Merwe, van de, 2008).

This is a study about how human beings interact when involved in a common property resource such as housing in condominium (Orban, 2006; Ostrom, 1990, 2009a). As Ostrom mentioned in her lecture when receiving the Nobel Prize in Economics in 2009, citing Douglas North (1990):

"The humans we study have complex motivational structures and establish diverse private-for-profit, governmental, and community institutional arrangements that operate at multiple scales to generate productive and innovative as well as destructive and perverse outcomes (North 1990, 2005)." (Ostrom, 2009a:408)

Ostrom's framework envisions human beings not only as rational and egoistic, or as helpless and trapped in the prisoner's dilemma, incapable of cooperating to manage and maintain their common property. In fact, and in real life, humans communicate and interact:

"When boundedly rational individuals do interact over time, it is reasonable to assume that they learn more accurate information about the actions they can take and the likely actions of other individuals..." (Ostrom, 2009a:430)

Therefore, in this research the starting point regarding the behavior of actors in the system is aligned with Ostrom's position. Rather than looking at communities of low-income homeowners as inevitably problematic or helpless, taking Ostrom's approach we observe their potential, their internal resourcefulness, and the mechanisms

through which satisfactory outcomes are to some extent achieved as perceived by the households themselves.

This research is not just about co-owners; it is also about their relationship with actors in the housing system. Professionals and developers are part of a network in which they often interact, developing common ideas and strategies to build affordable housing. The provision process leading to low-income homeownership in condominium creates a complex system among users (owners and tenants) and developers, together with the lending sector and the state.

If the goal is to understand, and then compare, which factors are associated with perceived maintenance levels of common property elements, it is necessary to unravel the meanings of homeownership in the condominium tenure and the housing system for low-income homeownership. As Stephens explains, housing tenure is an important institution in the system and goes to the heart of the 'distinctive' nature of housing in both comparative research and welfare policy (2011:345). To perform an institutional analysis of low-income homeownership policy in Latin America, a conceptual approach was chosen that foregrounds the institutions of condominium tenure and therefore brings the latent collective action dilemmas to light (Orban, 2006; Ostrom, 1990).

§ 1.2.1 Comparing Bogota, Colombia and Quito, Ecuador: Hypothesis

The literature generally discusses problems with condominium maintenance within a single institutional context. In contrast, this thesis discusses data from Bogota, Colombia and Quito, Ecuador. These two Latin American capitals have different property laws but similar subsidy policies for promoting low-income homeownership in condominiums. The underlying hypothesis is that this difference in property law impacts on the functioning of condominium development and management and in turn on maintenance outcomes as perceived by the residents themselves. Chapter 2 explains the comparative approach taken here and chapter 3 presents the research design, which was systematically applied in both contexts to permit comparison of the condominium situations.

Colombia and Ecuador have very similar policies for promoting low-income and middle-income owner-occupation. The policy regulates both the subsidy allocation process and the affordable housing market. Chapter 4 expands on this regulatory framework and gives information about the respective housing markets.

What distinguishes the housing systems of these two countries is their horizontal property law. It was updated in 2001 in Colombia, which at that point had the newest revised law on this kind of property of any country in Latin America. In Ecuador, the law dates back to the 1960s, though it was not codified until the 1990s, and some of its articles were most recently amended in 2011 in 2015. Colombia was chosen as the setting for a case study because its law is the most up to date. Since this formal institution was designed to make the property regime work, it can be assumed that the owners perceive its outcomes as optimal. The best way to know whether outcomes are in fact optimal is to compare them with outcomes in a similar affordable condominium housing system. Ecuador was chosen as the other setting for a case study because it has an older version of the property law, but also because it is the country of origin of the author of this thesis, which would makes the research environment more accessible.

Condominium tenure does not exist in a vacuum; it is influenced by the urban history of multi-family buildings in these capital cities, and by the social and the economic conditions of the context of study. I propose a framework to compare and analyze the different systems while taking into account specific institutions implied in the provision process of affordable condominiums. Scholars have been involved in long debates about what it really means to do comparative housing research that considers tenure as a key variable in the comparison of different systems (Elsinga, 1998; Oxley, 2001; Ruonavaara, 1993; Stephens, 2011). The recommendation is to focus on the legal aspects that make a tenure form internationally comparable and 'conceptually equivalent' across different national contexts (Pickvance, 2001).

§ 1.2.2 Condominium ownership and collective action

The literature on meanings of homeownership, such as the study by Saunders (1990), takes the position that although some of the benefits of homeownership do not necessarily derive from the tenure form, there are some advantages that come "directly from rights established through title to property" (1990:97). One of these is the 'right to modify', or the right to do as one pleases with the property (Saunders, 1990). As said before, homeownership in a single-family house is different than in a multi-family building. In multi-family buildings, one cannot do what one pleases with elements that belong to common property.

By law, the right to modify the property is constrained or enhanced by the collective property rights. For instance, it is possible to modify parts of the common property such as the facades if it is agreed to do so by majority rule in the assembly of owners

meeting, under which some of the costs can be collectively assumed. Taking into account the bundle of rights and the physical qualities of the resource, the common property can be a rival and non-excludable good. It is rivalrous because the use and over-use of the common property can reduce the availability of the resource to other co-owners. And it is non-excludable because co-owners that do not pay the maintenance fee, or that do not attend the assembly meeting, cannot be excluded from entering and using some of the basic common areas such as the stairs or elevators. Owners can be sanctioned when they do not collaborate but cannot be excluded from entering into their common property. But how easy or how difficult is it to sanction your next-door neighbor? Situations like these illustrate the ambiguous boundary between the formal rule and the informal one and influence decision-making and collective action (Orban, 2006).

§ 1.3 Thesis outline

The thesis is organized in three parts: (I) housing theory and methods, (II) condominium formal institutions, and (III) condominium informal institutions, followed by the conclusion.

Part I presents both the conceptual approach and the methods applied to understand low-income maintenance problems. Chapter 2 introduces theories of comparative housing research, revising the convergence and divergence comparative systems approach, and explains the middle-range approach, an approach in which both formal and informal institutions matter. Going deeper into the institutional debate in housing research, this chapter then examines the role of homeownership institutions and expands on how that role might change in reference to collective ownership in condominium. The second part of this chapter treats individual and collective ownership in condominium, including the bundle of rights, the collective action dilemmas, and their possible solutions. Finally, the Institutional Analysis and Development framework of Ostrom (1990) is presented as the main conceptual approach that guides this research.

Chapter 3 discusses the research design and the methods that were applied to answer the research questions posed in this thesis. It includes the methodological sections of the consecutive chapters, namely the process of data collection, methods for the analysis of property law, focus groups, and case-study selection for the quantitative survey. The sample design as well as the multiple variables and statistical methods applied are explained in this chapter.

After part I of the book, each subsequent chapter addresses a specific research question using either qualitative or quantitative data (see Table 1.1).

Part II turns to the formal institutions in condominium, first in light of policy and market data and second in terms of the property law. Chapter 4 gives some historical background on the changing role of government in housing policy, taking a path-dependence policy approach towards homeownership. The chapter explains the constitutional housing rights in both Colombia and Ecuador, and outlines the current subsidy policy for homeownership. Then the housing markets of Bogota and Quito are analyzed using census and cadaster data.

Chapter 5 focuses on the property law of condominium, which is the main formal institution of interest in this study and the one on which the main hypothesis of this thesis is based. This analysis takes a socio-legal perspective, explaining the structure of the law by showing who and what are regulated by it. The results of the comparative analysis advance our understanding of how this formal institution differs between the case-study cities. The identified differences and similarities form the basis for part III of the research.

Part III takes a broader view and introduces the informal institutions. It starts with two chapters on how condominium rules and maintenance problems are perceived by different actors. Chapter 6 uses information from the analysis of property law by looking into how professionals and government agencies perceive the maintenance problems of low-income condominiums. Then the external network of actors involved in condominium governance is sketched. The picture is assembled from the results of focus groups, demonstrating the interests of each party, the policy network characteristics, and the role of key professional actors in the system, such as the social manager, the property manager, and municipal property registry and cadaster departments.

Chapter 7 explores how low-income homeowners perceive their maintenance problems in a rule-structure situation such as found in the condominium regime. While chapter 6 presents the external actors, chapter 7 turns the attention to the internal actors: homeowners and residents in condominium property. The dependent

variable is the perceived maintenance level (PML) of their own housing complex. Using the IAD framework, a series of variables regarding (1) community socio-economic characteristics and trust, (2) property law, and (3) physical qualities of the housing complex are then explained which ones are statistically associated or not associated with the maintenance level. Both formal and informal institutions are tested using multivariate regression methods in Bogota and Quito.

The final part of the thesis resumes the application of the middle-range approach to the housing systems and housing theory. The condominium form of tenure involves formal and informal institutional variables, as will be demonstrated in the comparative analysis. Regarding policies to cope with the deterioration of low-income condominiums, this research makes some recommendations in the last chapter.

MAIN HYPOTHESIS	The more modern property law in Colombia has a positive impact on self-organization and in turn on the perceived maintenance level	
Chapter 1	Introduction	
Part I	Theories and Methods	
Chapter 2	Conceptual approach	
Chapter 3	Research design and methods	
Part II	Formal Institutions	
Chapter 4	Housing market and policy	
	Research questions	How have housing policies been adopted in both Colombia and Ecuador? How does the incentive-based policy work in producing condominiums? What are the differences or similarities?
Chapter 5	Condominium Law	
	Research questions	Who and what are regulated by horizontal property law? How does the regulatory system operate in condominium? What are the similarities and differences between Colombia and Ecuador?
Part III	Informal Institutions & Governance	
Chapter 6	Network of professionals	
	Research questions	How do professionals perceive maintenance problems? How do they deal with these problems? How do they perceive the role of the law? What are the similarities and differences between Bogota and Quito?
Chapter 7	Governance of low-income homeowners	
	Research questions	Which factors are related to the perceived maintenance level (PML) of the common property? Do these factors differ between Bogota and Quito?
Conclusion	Condominium housing institutions: governance and collective action Responding to the main hypothesis: the laws make a difference for maintenance outcomes	

TABLE 1.1 Thesis outline

2 Conceptual approach

This thesis makes a theoretical and methodological contribution to the field by integrating the institutional theory of the commons to the middle-range, comparative housing approach. With the aim of understanding homeownership under divergent condominium regimes, the theory of the commons was deemed appropriate to explain the institutional complexity of this form of tenure. Accordingly, the thesis integrates the Comparative Housing Systems approach with the Institutional Development Framework (IAD) (Ostrom, 1990). Thus, the overarching goal of this thesis is to use self-governance theories to understand formal and informal institutions within a comparative housing approach (Oxley & Haffner, 2012; Ploeger, Lawson & Bontje, 2001).

The comparative housing approach will be explained first, in section 2.2, since it frames the institutional analysis of a particular housing sector in the two selected Latin American countries. The key concepts and definitions in comparative housing research are related to housing institutions, specifically to meanings of tenure (Bengtsson & Ruonavaara, 2011; Elsinga, De Decker, Teller & Toussaint, 2007; Oxley, 2001; Toussaint, 2011).

The idea of homeownership in condominium is deconstructed, in section 2.3, by looking into the bundle of rights implied by the concept of a common property resource. Low-income homeownership within a common property resource inevitably runs into collective action dilemmas (Chu, Chang & Sing, 2012). In a subsequent search for solutions, Ostrom's IAD framework is a suitable starting point to diagnose the situation (Chu et al., 2012; Orban, 2006; Ostrom et al., 2006). The framework is suitable because it can help the researcher to understand and compare the complex system in which institutions of homeownership operate and change.

The complete institutional model to diagnose the structure of the situation is the subject of section 2.4. It should be kept in mind that in order to study the outcomes attributable to institutions and group behavior, it is necessary to choose a specific arena of action. To that end, section 2.4 defines maintenance as the 'action-situation' of this study. Maintenance is the arena in which it is possible to observe those rights and obligations that are not only individual but also collective. To evaluate the outcomes, the IAD model suggests the inclusion of the following variables that correspond to three levels: (1) the rules that individuals use, (2) the attributes of the physical world, and (3) the nature of the *community*. A cluster of these three factors can influence what occurs in the action-situation. Participants and their positions in that action-situation

are the relevant units of analysis; participants make decisions depending on the information they have, which depends in turn on their position, and these decisions are linked to costs and benefits and potential outcomes (Ostrom et al., 2006:27-37).

To close the chapter, section 2.5 summarizes how the theories explained here are to be applied. It elucidates the integration of Ostrom's theory with housing institutions, specifically regarding the study of condominium tenure.

§ 2.1 Comparative housing research

§ 2.1.1 Convergence versus divergence: A middle-range approach

Cross-national comparisons of housing problems, markets, and policies have been made since the 1960s. The researchers in that field generally cite Donnison's book, *The Government of Housing* (1967), as the starting point for comparative housing studies. His premise is that countries will proceed from pre-industrialism to post-industrialism, setting in train a transformation in social bonds and social policy due to urbanization, individualization, and industrialization (Heijden, van der, 2013). The role of government in these development phases will be to focus on either residual or more comprehensive housing policies. Thus, the idea and form of the welfare state and the role of housing are prominent in Donnison's thought. Without observing the differences between political or institutional backgrounds of the countries he compared, he identified three housing policy models: haphazard intervention, social or residual, and comprehensive. As Kemeny elaborates, Donnison's book does not actually refer to theory. Reading between the lines, however, one finds traces of convergence theory, since the result of evolutionary thought is the ultimate convergence of social structures (Kemeny, 1992). As argued in Donnison (1967) and Donnison & Urgerson (1982), "differences between the housing situation and the nature of the housing policy in different countries are connected with the developmental phase of the individual countries" (Heijden, van der, 2013:9).

The liberal point of view expressed in Donnison's work about the convergence of housing policies was challenged in the 1980s from a neo-marxist perspective (Harloe, Ball & Martens, 1988). Arguing within a framework of the structure of housing

provision (Ball & Harloe, 1992), they asserted that changes in policy cannot be studied as if they exist in a static institutional context, and that policy studies need to consider actions by market actors (Heijden, van der, 2013). The idea that housing policy is not isolated from other institutional and contextual factors started to take root in comparative housing research. That idea of embeddedness subsequently grew into a more systemic vantage point from which to study housing problems and policy solutions.

The structure of housing provision (SHP) approach suggests that the property rights regime is associated with the way that housing is consumed (Ball & Harloe, 1992). In this view, property rights are themselves a type of social relation, not only among owner-occupiers but with all of the stakeholders in the system as well (Ball & Harloe, 1992:3). As Oxley (1991) explains, the structure of provision is useful as a 'theoretical string' that helps to tie things together, similar to other views such as 'privatization' or 'convergence' in comparative housing research (1991:69). Ruonavaara (1990) notes that it is possible to use the SHP approach from a non-functionalist perspective by making explicit the mechanisms and actors involved in the system. Citing the work of Harloe (1981), where he explains the growth of homeownership in contrast to the unprofitable private rental market in the British context, Ruonavaara shows that there are elements that can help explain a systems view and its mechanisms by reformulating Harloe's account:

"The reformulated account identifies a number of actors: suppliers seeking profitable investment opportunities, consumers making choices to obtain the desired kind of housing and policies searching for solutions and electoral support. These are also the main actors of previous models, now linked together in one model. The outcome, the growth of owner-occupation, is an unintended (but probably not unanticipated) result of the actions of the different actor groups pursuing their own objectives. The role of consumers is twofold but not a very active one: on one hand their resources make home-ownership profitable, on the other hand they constitute the electorate the politicians draw their support from. The other two actors categories are the more active ones." (Ruonavaara, 1990:140)

In this paper Ruonavaara explains that in the reformulated account of the structure of the housing provision, the state and its policy are key participants interacting with and supporting the tenure change in the system. Ruonavaara's interpretation also reflects

the systemic view of the SHP framework as a complex interplay of actors with different interests and powers. Seen in this way, the SHP approach is useful because it draws upon provision phases to portray each actor's interactions.

The divergence theory developed by Kemeny introduces new conceptual approaches to housing welfare regimes, as derived from Esping-Andersen's typology of welfare states. His main point is to give a central role to housing, not only in society in general but in welfare states in particular (Lennartz, 2011). Regarding rental housing systems in European countries, Kemeny observes that a dominant tenure form will influence the welfare state from a wider perspective (Lennartz, 2011:347). Advanced industrial societies in countries where homeownership predominates are associated with a privatist ideology and a residual policy of welfare (Kemeny, 1992, 1995). On the other hand, societies with a representative rental sector are associated with ideologies of collectivism and more commitment to welfare provision (Hoekstra, 2010).

A lesson to be drawn from Kemeny's position is that housing should be considered in context, which means looking at both homeowning and rental societies. This also means looking into the historical tendency of a society to pursue a certain path towards a preference for a certain kind of housing policy. The divergence approach is supported by the path-dependence theory in housing; in short, history matters, since it influences social and political processes (Bengtsson & Ruonavaara, 2010; Malpass, 2011).

This section comes to grips with the theoretical and methodological grounds of the scholarly work on comparative housing research. A more systemic approach to the study of housing situations has been developed to encompass the institutional complexity in which housing markets are embedded (Boelhouwer and van der Heijden, 1992; Hoekstra, 2010; Heijden, van der, 2013). Therefore, Boelhouwer and van der Heijden (1992) proposed a systemic approach in which housing systems are not determined by economic and demographic developments alone. This approach explains why systems matter and includes both policy outcomes and institutional frameworks, which are necessary in order to compare housing systems in different countries.

Comparisons of housing systems are carried out for many purposes (Lawson, 2001; Lundqvist, 1991; Bengtsson & Ruonavaara, 2011). These include the evaluation of policies, their transferability, and outcomes, as well as the development of welfare theories following the convergence or divergence path of housing policies (Doling, 1997; Heijden, van der, 2013; Hoekstra, 2010).

Theoretical approaches and methods have been evolving in order to explain rather than just describe "similarities by common processes and differences by variation" in the

housing systems of the countries or localities of study (Oxley & Haffner, 2012:199). In the search for explanatory models, and as explained above, different approaches have been applied to conduct international comparative research as a way to explain and theorize the differences and similarities between housing systems (Bengtsson & Ruonavaara, 2011; Boelhouwer & van der Heijden, 1993a; Doling, 1997; Harloe & Martens, 1984). Two methodologies have traditionally guided the housing debate: the universalistic and the particularistic.

A basic tenet of the universalistic approach is that the terminologies used to describe tenure forms are the same regardless of the context. This kind of research assumes that homeownership and private and social renting are equivalent, and the studies describe similar phenomena in all countries included in the comparative studies (Hantrais, 2009). A prime example is the body of housing reports produced by UN Habitat or the World Bank, organizations that need to generalize about housing conditions in order to develop global indicators. The main difference between universalistic and particularistic approaches lies in the level of generalization.

While the universalistic approach generalizes and tries to establish the unilinear and global dimensions of phenomena, the particularistic approach only juxtaposes one country against others, whereby generalization is not the main goal (Kemeny & Lowe, 1998). The highest level of generalization is pursued in the universalistic approach, which seeks to discover similarities, assuming the convergence of development paths with a causal relation to welfare and housing. These two approaches define the two extremes on the continuum of comparative housing research. However, over the last few decades we have seen the emergence of a middle-range approach seeking to “propose typologies of housing systems derived from cultural, ideological, political dominance or other theories as the basis for understanding differences between groups of societies” (Kemeny & Lowe, 1998:161-162).

Haffner et al. (2009, 2010) proposed using a ‘middle-way’ approach to understand the private rental sector in different European countries. Their rationale for preferring a middle way is couched in the debate on tenure form in comparative research. They argue that “even though there is a large variation in tenure forms, it is still possible to construct a typology of housing tenure that uses categories that are similar enough to allow comparison across countries” (2010:359). Their approach does not emphasize differences, which would imply that private renting is unique to each country; nor does it emphasize similarities, which would imply that private renting is the same in all countries. Instead, their study of the private rental sector places emphasis on and is embedded in the historical and cultural context (Haffner et al., 2010:366). But to identify patterns and typologies, the middle-range approach needs a grounding in theory. Recognizing that need, the researchers justify the use of their approach on

three conditions: commensurability (forms of tenure can be comparable); context; and theory. They call for more qualitative research to flesh out the three conditions for conducting comparative analysis (Haffner, Hoekstra, Oxley & van der Heijden, 2009).

The debate (see also Elsinga & Hoekstra 2005; Hoekstra, 2010; and Heijden, van der, 2013) cites European studies or research done in countries with similar industrialized patterns of development. But more and more, the debate refers to housing systems and policy from other parts of the world; for example Choe (2011) has done such work in South Korea. Therefore, the middle-range approach, where history and context matter, is a comparative framework that is particularly suited to the Latin American context. It allows systemic analysis of countries that might appear homogeneous (such as Latin American countries) but actually differ when phenomena are observed in context and through an institutional lens.

The welfare typology was developed for European comparisons of housing systems. Although it is interesting, that typology is not so useful to explain the current situation in Latin America. As other scholars have noted, housing policy in the Latin American region cannot follow the same social democratic, corporate, or neoliberal welfare regime typologies used in the most advanced capitalist countries (Balchin & Stewart, 2001:334). As these authors note, housing policies have developed along a different path in Latin America. There, housing policy has consistently concerned low-income homeownership throughout the twentieth century. Despite the different political regimes, from dictatorships to conservative democracies, other neoliberal and even socialistic democracies, housing policies regarding the formal provision of housing for low-income and working-class families have predominantly been low-income homeownership schemes.

Comparative housing research can be applied to improve housing policy implementation and to facilitate the transplantation of policy from one context into another (Oxley, 2001). However, in order to make comparisons useful, they would “all have to be based on an understanding of the meanings and definitions of tenure” that pertain in each country being compared (Haffner et al., 2010:358). Consider the debate on housing asset-based welfare and the meaning of housing for welfare (Castles & Ferrera, 1996; Doling & Elsinga, 2013; Doling & Ronald, 2010; Groves, Murie & Watson, 2007). For many countries, asset-based welfare is the housing welfare regime of the future. To make this welfare regime work, contextual factors of both formal and informal institutions are important (Toussaint, 2011).

For example, policies and informal institutions, such as the cultural meaning of a home as an asset, do matter in the release of housing equity (Toussaint, 2011). She demonstrates how formal and informal institutions interact at the household level in

building up and releasing housing equity. In summary, housing research in the Delft group has shifted its focus away from policy towards systems analysis, applying a middle-range approach to compare housing systems by analyzing and unraveling the institutions involved.

The following sections define how housing institutions in general and condominium tenure in particular contribute to an understanding of the subject of this study.

§ 2.1.2 Housing tenure institutions

"Housing occupies a unique place in people's lives. As the reference point of daily life, it is the prime reflection of individual desires, hopes, needs and status. It protects privacy and self-determination, yet is strongly affected by political, economic and social developments." (Toussaint, 2011:27).

It is not a simple task to unravel the meaning of housing tenure, picking out the various political and institutional contexts together with the diverse meanings attached to the tenure forms (Elsinga, 1998; Ruonavaara, 1993). Social renting in the Netherlands is institutionally different than renting in a Scandinavian country. And institutional differences deserve attention when making housing market comparisons. In Latin America, homeownership in an informal or self-help settlement is different from homeownership of a dwelling produced by developers, although both may be intended for low-income families and both certainly occupy a unique place in people's lives. In the Latin American census data, the tenure in both settings is categorized as homeownership, following the type and not the form of tenure involved (Ruonavaara, 1993). Housing census data generally refers to taxonomic forms of tenure and does not give information on the substantive characteristics of the tenure form (Barlow & Duncan, 1988). Therefore, important details on the provision, actors, and institutions cannot be understood by looking only at the country's statistical housing surveys.

The concept of housing tenure may be hard to apply if it is not clearly explained. Ruonavaara (1993), joining the discussion started by Barlow and Duncan (1998), asserted that there are basically two types of tenure, owning and renting, which are categories that allow for general cross-national comparisons. However, instead of

what Barlow and Duncan (1998) called the *substance* of a particular type of tenure, it is better to consider its *form*, referring to the particular “historically and geographically specific institutional arrangement through which possession of housing is organized” (Ruonavaara, 1993:11). When studying housing in condominium tenure, one is observing a form of tenure, including the institutions behind a complex development process and the bundle of rights involved.

Owning a home (as a private and individual good) is a very recent phenomenon in urban history (Saunders, 1990). It is surprising that the desire to own a house has not been questioned but rather is considered self-evident. The role of housing (and the land it occupies) has clearly become a key economic asset in capitalist societies (Piketty, 2014). Over the twentieth century, owning one’s home came to be understood as a *natural* desire and a source of *housing satisfaction* in human beings (Elsinga & Hoekstra, 2005). Some assumptions about homeownership are obviously tautological, both in research and political discourses: because many people own and would like to own, making all kinds of sacrifices and major life-course decisions on this basis, it is common to assume that *of course* everyone wants to own their own place. As Saunders puts it, homeownership has become a fact of life that is rarely questioned (Saunders, 1990:59).

Studying the British case, in his book *A Nation of Home Owners* (1990), Saunders continues a long-standing debate in housing studies about the expected social and economic benefits of being an owner in contrast to being a tenant. He is worried about the outcomes of contrasting ownership and renting, since it neglects issues of class and inequality that affect the more vulnerable households and individuals who cannot afford to make homeownership a sustainable goal. In other contexts it has been demonstrated that both renters and homeowners can experience the same level of satisfaction. Most of the time the social status and the quality of the dwelling are at least as important as the role of tenure. The meanings of homeownership can therefore differ, depending on the institutional and cultural context of study (Elsinga, 1998:138).

In a seminal paper, Marcuse (1972) discussed the sometimes dangerous assumptions that are made about the financial benefits of homeownership for low-income people. He described five financial issues that are generally assumed as benefits of homeownership in comparison to renting: investment opportunities, maintenance advantages, tax benefits, transfer costs, and risks of change in housing cost. In terms of maintenance factors, Marcuse pointed out that owner-occupier homes may be better maintained than homes where the owner is an investor and does not live in the property. When an owner is also the occupant, he or she is close to the physical problems and can decide more promptly to attend to issues than an owner-investor

who has a tenant in the unit. For Marcuse, there is a difference in attitudes when comparing the owner-occupier with the owner-investor. For the owner-occupier, two interests are more important than money when considering proper upkeep to a property: “they have pride, status, personal enjoyment, community respect, and other such intangibles pushing them” (Marcuse, 1972:140). The other expected benefit is financial, since with good maintenance, the value of the unit to the owner will be greater. However, as Marcuse also noted, these issues can change depending on legal or institutional arrangements. In light of these issues Marcuse questioned whether these assumptions would still hold when the observed population consists of owner-occupiers in low-income condominiums.

Marcuse’s main concern is the danger of taking ownership’s financial benefits for granted without considering the possible outcomes. For example, observing the market effects of owner-occupancy, he noticed that low-income owner-occupiers can be caught up in the processes of neighborhood decline, which are generally followed by a “decrease in real estate prices, aging of the housing stock, reduced maintenance and increased deterioration, increased density of occupancy,” among other effects (1972:139). There are many other factors that can affect policy outcomes in low-income homeownership policies. He concluded that “the answer to the stance that public policy should take towards homeownership for low-income families lies in the possibilities of institutional changes in existing tenure arrangements, and in the social or political, not the financial characteristics of homeownership” (Marcuse, 1972:143). The recommendation is clear: to focus on tenure institutions and their complexity.

The debate about the natural desire for and benefits of homeownership appears to be fed by the situation in Europe or the USA, but it is also pertinent to Latin America. Ideas about ‘a home of one’s own’ are reflected in policies such as those governing low-income subsidized homeownership in Latin America and even in the policies that secure tenure in the informal settlements (Ward et al., 2014). Both the formal provision of low-cost dwellings and the existence of land titling programs are based on familiar ideas about housing as being important for households in terms of self-determination and economic stability. Some scholars have studied the outcomes of the titling programs for informal settlements, hoping to find the dreamed-for capitalist land market envisioned by De Soto (2001). Considering De Soto’s book “primarily as a mystification of property law,” Gilbert (2002) noted the existence of enough evidence that “actually contradicts the claim that granting formal property rights is a central ingredient of housing improvement” (Gilbert, 2012a:vii). Security of tenure in Latin American self-help settlements is granted in many other informal ways, and people improve and continue building their self-help dwellings either with or without a property title. However, as the longitudinal research done on consolidated settlements

in selected Latin American countries demonstrates, new policies to rehabilitate and improve the self-help innerburbs (former suburbs) are necessary (Ward et al., 2014).

Nevertheless, in many cases ownership or possession of a home can contribute to securing the social and economic lifecycle of a family. As a resource, a home can create benefits that might bring the family out of poverty (Moser, 2009). Moser's research shows that a home can become an asset that generates income when the resident sets up a small business in it. Living rooms of low-income dwellings are commonly transformed into barbershops, stores, or seamstress workshops. These enterprises are often organized by women in order to generate income while keeping up with their household and childcare responsibilities. By focusing on these kinds of resources, Moser contributed to the homeownership sustainability debate by showing both the 'tangible and intangible assets' the poor actually have instead of focusing on what they do not have. By doing research in a low-income self-help neighborhood in Guayaquil, Ecuador, Moser discovered that housing is a tangible productive asset connected with intangible ones such as household relations and social capital (Moser, 1998). Moser's research and methods demonstrate the value of including both formal and informal institutions in the study of poverty and housing-related problems.

The focus of these perspectives on homeownership is the individual household, which corresponds with the focus of most scholarship: the owners of single-family houses. Separate debates concern the benefits of homeownership and owner-occupation as a preferred tenure type, but little research has been done on what it means to be a homeowner in multi-owned complexes, which are typical under the condominium regime (Blandy, Dupuis & Dixon, 2010). Many of the individual responsibilities as a homeowner still pertain in condominium. Yet others, such as maintenance or the freedom to set up a business in your home, are highly constrained by the community and the form of ownership involved. Since there are formal rules that can shape the way multi-ownership is arranged, the ownership form in itself might not be as disadvantageous as the social dilemmas that may arise in a property that is collectively owned.

Looking at a housing system from an institutional perspective, the focus is on the various arenas in which actors meet. Within those arenas they adapt to the rule-structured situation of tenure and policy and simultaneously to other actors' behavior as well (DiMaggio & Powell, 1983). In this thesis, these arenas are assumed to arise in response to the condominium institutions and the housing provision process. Both create the environment in which actors will consider their strategies and where they will take their chances and develop either cooperative or conflictive positions when following their interests. Bengtsson (2012) asserted that tenure institutions are important in research efforts that aim to integrate the role of households and of

other actors around them and their effects into the analysis of policy outcomes. As he explained:

"Housing tenures should be seen as the most important political institutions of housing provision as welfare state policy. Forms of tenure are vital to housing policy and implementation at all levels because they define the formal position of residents in their capacities as owners (Bengtsson, 2012:209)."

One of the main lines of inquiry found in current work on institutional analysis within the fields of economics and sociology concerns how institutions change. While change refers to how the actors in interdependent relationships adapt to other actors in the network, institutional change refers to how actors behave within a rule-structure arena, more specifically, to how they follow or modify rules when developing formal or informal monitoring and sanctioning processes (Nee, 1998).

By linking the institutional theories to the housing systems approach, two questions come to the fore. How do the tenure institutions of the system (formal and informal) influence (or change) actors' behavior. And, in turn, how does institutional change influence policy outcomes? Boelhouwer and van der Heijden (1992) noted that in housing market and policy research a key issue remains unresolved: "what the influence of similar institutions is on the actions of government" (1992:11). Since then, institutional analysis in multi-owned housing research has revealed critical aspects of actors' governance and the functioning of the network that have measurable effects on markets and policy (Alterman, 2010; Orban, 2006; Yau, 2014; Yau & Ho, 2009).

Ostrom defined institutions broadly as "the prescriptions that humans use to organize all forms of repetitive and structured interactions including those within families, neighborhoods, markets, firms, sports leagues, churches, private associations, and governments at all scales" (Ostrom, 2005:3). Nee and Ingram defined an institution as a "*web of interrelated norms* – formal and informal – governing social relationships" (Nee & Ingram, 1998:19) (emphasis in the original). The mechanisms and the effect of the interaction between formal and informal institutions like those discussed in this thesis constitute the core of the scholarly debate within institutional theory.

The institutional approach focuses on the rules of the game. These are either formal rules such as those based on property law or informal rules such as those based on

the trust that develops (or fails to develop) between actors. In housing research, it is necessary to recognize that sometimes “households’ norms and routines diverge from the rationality assumptions” (Toussaint, 2011:9). Moreover, households’ behavior might also diverge from the stipulations of the property law and policy. This kind of ‘non-rational’ behavior is not confined to households, though. Other actors in the housing system can behave in rather informal ways within the rule-structured situation, developing strategies and actions based on trust with the goal of increasing efficiency in policy implementation.

Scholars in the fields of economics and sociology have been seeking agreement on the levels that exist in institutional analysis and its mechanisms (DiMaggio & Powell, 1983; Williamson, 2000). The work of the Nobel Laureate in Economics (2009) Elinor Ostrom demonstrates that it is possible to accept the institutional diversity involved in structured human interactions, which can help to avoid indeterminacy in the research on social and economic behavior (Ostrom, 2005). Ostrom and her colleagues developed the Institutional Analysis and Development (IAD) framework as a tool to study the diversity of institutions involved in both common pool resources and common property resources.

Institutional views on the housing provision process, such as the one proposed by Ball (1998), clarify that the ‘structure’ of interest is the “network of organizations and market involved in a particular form of building provision” (1998:1513). Both organizations (actors) and markets (dwellings in demand and supply) influence each other and are constrained by the same rules of the game in the context of any specific particular housing sector and policy process. As the housing systems research group at OTB, TU Delft understands it, the institutional level is precisely where the demand and supply side of the housing market meet (Heijden, van der, 2013). This institutional view is contingent on the historical and political process under which the provision of housing is taking place (Bengtsson, 2012; Boelhouwer & van der Heijden, 1993b; Malpass, 2011). In the end this is a ‘nested’ approach that focuses on *tenure* as the specific arena in which to study institutions from a systemic point of view.

On one hand, the formal institutions that this thesis investigates follow the two basic rules that bind actors in the particular housing systems under study. As it is defined in Baldwin (1990), a ‘rule’ refers to written statements, such as legislation, a code of practice, or guidance notes, (Baldwin, 1990). Accordingly, “enforcement of the rule does not only look at the formal prosecution, but to all forms of compliance-seeking” (Baldwin, 1990: 321), such as those established informally within the policy networks and communities of owners. Rules are also called regulations, such as the internal regulations in condominium property (statutes) or ‘policy by regulation’ (Black, 2002), as in the case of the subsidy policy regulating the market for and provision of low-cost

dwellings in Colombia and Ecuador. The government regulates for a public purpose, but policy implementation is no longer centralized within the government structure (Baldwin & Cave, 1999). These housing policies or rules are designed to regulate different actors in the policy network; policies are considered in the institutional and regulatory debates as a 'decentered' form of the state (Black, 2002).

The first formal institution examined in the research is the policy law that regulates the housing market of low-cost dwellings that will be purchased by low-income families. The subsidy policy defines the price and minimum size of the dwellings and also stipulates some of the mechanisms for subsidy allocation. The policy regulation is considered comparable for the two selected countries from Latin America (an analysis of these regulations will be presented in chapter 4). The second formal institution, which is central to the research, is the law of horizontal property or condominium. The condominium law is the formal institution designed to constitute, regulate, and facilitate condominium governance.⁶

On the other hand, the research identifies the informal institutions that have developed around the formal ones. This requires the investigator to focus on actors' perceptions of the problem, which will reveal the 'informal institutions' (Toussaint, 2011:11). The only way to study institutions is to see them in action, observing which actors interact and how they behave in a particular *action-situation* such as that surrounding maintenance practices regarding the common property. This research chooses *maintenance* as the particular situation that brings actors together. The factors affecting the action-situation of interest are set forth in section 2.4 of this chapter.

Williamson's (2000) work in institutional economics has found that the definition of actors used in institutional analysis is useful because it focuses on key attributes of actors whose behavior is studied, including their positions and the resources they share. Studies of social human behavior can be broad and complex, as behavior is studied by almost all social science disciplines. Therefore, as Williamson elaborated, there is close unanimity in institutional analysis "on the idea of limited cognitive competence – often referred to as bounded rationality." He pointed out that there are cognitive limits on the complex contracts and that some explanations are 'unavoidably incomplete,' especially when considering the opportunistic behavior that actors sometimes demonstrate (2000: 59-60). However, he also pointed out another quality that can help balance incompleteness: foresight, or the capacity of actors to imagine and see problems (Williamson, 2000:60).

Actors in the housing system of study have choices; in Ostrom's (2005) words:

"Individuals interacting within rule-structured situations face choices regarding the actions and strategies they take, leading to consequences for themselves and for others (Ostrom, 2005:3)."

This notion of a chain of events is important in the present research. It helped the investigator to visualize and focus on an action-situation in which actors' interactions might have a systemic effect on the outcome: they have consequences for themselves as well as for others. Policy problems or a lack of maintenance affect not only the households but also other actors, including the state, developers, and the lending sector. Therefore, interaction between external and internal factors is considered here, as implied in Ostrom's IAD framework set forth in the next section.

§ 2.2 **Condominium: Individual and common property**

§ 2.2.1 **Bundle of rights in condominium**

The 'bundle of rights' refers to "all the various rights obtained by ownership of property" (Blandy et al., 2006:2366). Going one step further to understand owner-occupation in condominium, it is important to see that it mixes individual rights with collective rights; therefore the implications of this regime are better understood by looking at rights and obligations in a 'bundle'. The formal institutions have to be the focal point of analysis when the tenure form is seen as the key factor in the policy system. From that perspective, the investigator is better prepared to later understand how actors both interpret and change those rules in their everyday practices. Therefore, this section delves into the rights in a common property, which are more complex than just the right of alienation (*sale or transfer*) of a property. Special attention is given to those rights and obligations regarding *maintenance*.

The bundle of rights is a particularly useful angle from which to study governance institutions in common property resources (Ostrom, 2005). However, researchers studying condominium problems from a socio-legal perspective on the property law (Blandy et al., 2006; Blandy & Hunter, 2012; Edelman & Suchman, 1997) have also used the concept. The advantage of the 'bundle of rights' view is that it draws attention to those rights that are linked to or 'nested' in other rights with respect to the collective ownership and management of a common property resource (Ostrom, 2007), such as occurs in the condominium regime.

Ownership rights in common property are more complex than the individual right to sell and make a profit or to transfer. For example, in a common property resource, there is a *collective right* to exclude others from access and use of the private resource (Ostrom, 2003). The understanding of those collective rights is important since, in practice, individual property rights are contingent on collective rights. Blandy and Goodchild explain that the bundle of rights view has "the merit of shifting the focus of analysis away from a home (or any other land use) considered as an object to the interests of the different parties involved in buying, selling and living in a home" (Blandy & Goodchild, 1999:34). The bundle of rights, therefore, shifts the emphasis to the relationships that actors have with each other regarding a 'thing'.

Conventional wisdom divides individual property rights into three major categories, namely private, state, or communal rights (Demsetz, 1967:354). But, according to Poteete, Janssen and Ostrom (2010) this division does not reflect other institutional diversity existing in different property rights systems (Poteete, Janssen & Ostrom, 2010:46). Property rights, as defined by Ostrom, "define actions that individuals can take in relation to other individuals regarding some 'thing'; and if one individual has a right, someone else has a commensurate duty to observe that right" (Ostrom, 2003:249). As Schlager and Ostrom explained, "*rights* refer to particular actions that are authorized, and *rules* refer to the prescriptions that create authorization" (Schlager & Ostrom, 1992:250) (*italics mine*). Both rules and rights are therefore formal institutions.

Many studies on common property resources have been conducted, providing empirical grounds to propose the existence of five rights in the 'bundle'. These are access, withdrawal, management, exclusion, and alienation (Schlager & Ostrom, 1992), which are defined as follows in Table 2.1.

Access:	A right to enter a defined physical property
Withdrawal:	A right to obtain the “products” of a resource
Management:	A right to regulate the use patterns and transform a resource system by making improvements
Exclusion:	A right to determine who else will have the right of access to a resource and whether that right can be transferred
Alienation:	A right to sell or lease any of the above four rights

TABLE 2.1 Bundle of rights in common property resources (Source: Ostrom, 1992:250-251)

Scholars studying institutions of the commons have noticed that, depending on the rules, these rights can be constituted, monitored, or controlled by *collective-choice* rights and *operational-choice* rights. These two categories may be used to classify the individual and collective rights that are involved in a common property resource, depending on who possesses the rights. Especially when observing management strategies of the common resource, the rights of both individuals and collectivities can include some or all of the rights mentioned above. For example, a family has the right to access and enter into a national park (a common *natural* resource) and can purchase the operational right to use and enjoy the natural park facilities. However, the family does not have the right to harvest the forest (Ostrom, 2003). The family in this example becomes an ‘authorized entrant’.

In a common property resource, the owners are not the only parties to operational rights. There are also other users of the property, such as tenants, workers doing maintenance, or the property manager. In a condominium (a common *property* resource), an owner of a unit using its right of alienation can put the unit onto the rental market. The tenant enters the community as a user, purchasing some of the *operational-choice* rights of use of the common property. Tenants, as ‘authorized users’ according to the collective-choice rules (under condominium law), do not have the right to vote in the assembly of owners; they only have the operational-choice right to enter and use the common property.

As Ostrom (1992) explains, “the rights of authorized users are defined by others who hold collective-choice rights of management and exclusion” (1992:252). Regarding users such as tenants, however, there are specific rules protecting their rights and obligations. Therefore, in the condominium law, which is at the same level as the tenancy law, the relationship between the owner and tenant is defined under the principle of solidarity and responsibility for the property that is being rented out. This relationship is not yet well documented in the housing literature, but as will be evident from the empirical data presented in the next chapters, tenants are important users and, in the end, participants in common resource management.

To summarize, Table 2.2 below shows how the five rights are associated with different positions or actors involved in condominium tenure. Special attention is given to the right and obligation to manage and maintain the property, which is the phenomenon that we are investigating as a problematic housing policy outcome. Rights and obligations augment or diminish, depending on the actor's position. In the table, owners are included both as a collective (i.e. the assembly of owners, which is the only formal moment when key decisions can be made) and as individuals, on the basis of their rights regarding the interior and private space of their dwelling. Other actors' positions are as the authorized claimant and user and the authorized entrants.

	Owners in HOA	Owner*	Authorized claimant	Authorized user (tenant)	Authorized entrant
Access	x	x	x	x	x
Withdrawal	x	x	x	x	-
Management	x	<—	x	-	-
Exclusion	x	x	-	x	-
Alienation	x	x	-	-	-

TABLE 2.2 Bundle of rights in condominiums associated with positions (source: adapted from Ostrom (2003:251))

* Owners, as individuals, have four rights regarding their private space (interior of the flat) and five rights in collective spaces (as shown by the arrow <—).

HOA = Homeowners association

Owners in assembly meetings have all five rights regarding the common property. In the literature on multi-owned housing, the association of homeowners, or HOAs as they are called in the USA (McKenzie, 1994) and VVEs in the Netherlands (Meijer & Smid, 1994; Weesep, van, 1984), are similar forms of condominium owners' associations. 'HOA' is an umbrella term covering many other forms of collective ownership; it is not unique to condominiums. The reason for including the position of owners in the *assembly* rather than in the *association* is that the laws in the context of this study use the wording Assembly of Owners when referring to the association and the key meeting moment of owners. Moreover, in this particular analysis it would be redundant to use the term HOA: owners in condominium are by default already associated. Deconstruction of the rights and obligations is therefore critical. Owners practice and exercise their rights explicitly during the assembly meeting. According to the formal rules, *owners in assembly* is the only moment when decisions to adopt new rules, such as establishing a maintenance budget or hiring a property manager, can be made. The minutes of a meeting are a legally binding document.

The condominium regime recognizes individual property as well. An individual owner has the right of access, withdrawal, exclusion, and alienation within a particular private

and exclusive space. The right of access can be connected to some of the collective-choice rules. For example, the right to grant access (and to exclude someone) from one's own home (the private and exclusive space) is guaranteed, but what residents do inside their homes can relate to operational rules established for the collective, such as regulations for keeping quiet after midnight, restrictions on having pets inside the flat, or any other social and informal rule regarding good-neighbor relationships. Alienation is also better defined in conjunction with collective-choice rights. For instance, an owner individually owns a flat, to be used as a residence, but does not have the right to change its use from residential to commercial unless this is agreed unanimously in an assembly meeting, which would make the necessary changes in the general regulations of the common property.

The right to manage, in principle falling under the collective-choice arrangements, could be construed as the fifth right for individuals, in view of the physical attributes of the resource. It is a gray area, in that sense. Management and maintenance decisions depend on the kind of intended improvements. If improvements are made to kitchen cabinets, which technically belong to the interior and fall into the exclusive ownership domain, then it is possible to make improvements independently. However, if the desired improvement involves changing the location of the kitchen or moving walls, then this intervention would require a redesign and change of the communal water pipes, sewage, and electricity systems. Since such extensive renovation would impact elements that are part of the common property, then, according to the property law, permission from the management of the building would be required. It may or may not be possible to obtain their permission, since it is contingent on collective decision making.

Another example is the maintenance or renovation of windows to improve insulation for energy efficiency. Like any other element of the facade, windows are part of the common property. Renovation of the facade can clearly benefit all parties, due to the physical improvements, overall increased quality, and energy consumption of the building. Since the facade is common property, its renovation and the costs thereof may be assumed in collective. However, due to problems and difficulties in decision making, including a lack of interest or inability to pay for renovation, owners sometimes decide to carry out improvements by themselves. The other scenario is that the association of owners could decide to renovate the facades without requiring the contribution of some owners. Owners in condominium do not have the right to avoid management responsibilities, according to the collective-choice rules.

Other actors besides owner-occupiers are also involved in the management of the common property. An authorized claimant is a person who has 'operational rights' given by the owner. When there are owner-investors, such as those who leave and rent

the units to others, the rights and obligations are sometimes assumed by a family member or other person external to the community of owners. An authorized user such as a tenant may or may not be an authorized claimant. Under a contract with a tenant, the owner passes on some of the rights of use for both the individual and common property parts of the property. Owners can sometimes give their tenant permission to attend the assembly of owners and vote in their name, thereby transferring some of their rights and obligations to participate in management. A tenant acquires the right to exclude others from the individual private rented space, but he or she does not have the right to exclude others from the common spaces. An authorized entrant, for example, can be a visitor or an external property manager hired to take care of maintenance of the common property. It can also be a person working with individual households (like a nanny) who would first need permission to enter into the private common property before going into a private apartment.

The objective here was to give an indication of the contents of a particular 'bundle of rights' and how its composition can change, depending on who holds the rights and at what level (collective or operational rule). Its composition also depends on the physical aspect of the property: the 'thing' can be a common property element, or it can be the individual and exclusive space inside an apartment or unit.

To close this section about the condominium bundle of rights, there are two clear distinctions to be made. First, in each property that is under the condominium regime there are several formal rules, ranging from the property law to the internal regulations that are required by law. In this thesis, it is clear that the *rights* are not equivalent to the *rules*: "for every right an individual holds, rules exist that authorize or require particular actions in exercising that property right" (Schlager & Ostrom, 1992:250).

The second distinction, which will be better explained in the next section, is the fact that the condominium bundles of rights and rules create a common property resource (CPR). The distinction is made in terms of the rights of excludability and because the common property is also a rival good. Owners have the right – in collective – to exclude others from physically entering into the boundaries of their resource. And it is rivalrous because the use and overuse of the common property can reduce the availability of the resource to other co-owners. The complex bundle of rights is an indication of the latent collective action dilemmas that come to light when looking at everyday practices and decision making for maintenance of the common property.

The next section expands on collective action dilemmas in condominium. As Ostrom et al. (2006:15) explained, not all situations in common property resource management are dilemmas.

In institutional economics, collective action dilemmas are the informal institutions that arise around a rule-structured situation. Collective action might have an effect on the economic and policy outcomes (Assche, Beunen & Duineveld, 2014; Ostrom, 1990). As discussed above, actors are not purely rational individuals, so they may exhibit either non-cooperative or cooperative behavior. The possibility of collective action dilemmas is the distinctive feature of homeownership in condominium. Well known theories have been used to explain collective action dilemmas in organizations. This thesis turns to the Institutional Analysis and Development framework (IAD) of Ostrom (2005) to understand collective action dilemmas as they relate to the comparative analysis of the two condominium housing systems under study.

§ 2.2.2 Collective action dilemmas

The effect of the institutions in condominium on maintenance of the collective resource can best be appreciated in light of the latent collective action dilemmas that individuals and the group of owners will face to achieve a *collective good*. The collective good in this study is the level of maintenance of the common property parts.⁷ The social dilemmas that arise can affect the process of collective action and, in turn, the outcomes. This section links the literature about collective action dilemmas to the institutional analysis of the condominium regime. That background was essential to the research design and analysis since it helped define the variables that come into play when institutions are in action.

Marcus Olson (*The Logic of Collective Action*, 1965) theorized about groups' collective action dilemma. Orban (2006), who used collective action theories to explain groups' cooperative behavior in Hungarian condominiums, explained that collective action theory is "concerned with the question of how people behave and act in groups when pursuing their common goals, how *collective action for a collective good*, that is cooperation, can or cannot take place" (Orban, 2006:13) (emphasis in the original). Olson's seminal work proposing the theory of collective action helped to explain key aspects of group behavior as it affects policy and economic development. He challenged the traditional group theory, which poses that groups or organizations are formed by individuals with common interests (Ostrom, 1990). But their common interests may

7

In condominiums, there are different collective goods that may be studied; *maintenance outcome* is just one of them. Others might be small collective action-situations such as attendance of the assembly meeting of owners or a particular decision on the maintenance budget.

or may not be sufficient to guarantee collective action (Olson, 1965: 2). For Olson, the outcome of the group behavior depends on individual incentives and choices:

"What a group does will depend on what the individuals in that group do, and what the individuals do depends on the relative advantages to them of alternative courses of action (Olson, 1965:23)."

Individual choices regarding a collective good depend on the characteristics of the goods and the community involved. First, regarding the characteristics of the good, as explained by Ostrom (2003), Olson's initial theoretical contribution is to distinguish those goods from which it is possible to exclude others. Excludability of a resource creates the differences between a common pool resource and those of common property resources:

"Whether it's costly or not to exclude beneficiaries from consuming a good, once it is provided, is the most important theoretical distinction to be made among goods. It separates those where temptations to free ride exist and goods where individuals cannot free ride and still benefit (2003:261)."

Another important distinction pertaining to the condominium is the characteristic of rivalry. A common good is rivalrous when "consumption of units by one person subtracts from the availability of benefits to others" (Ostrom, 2003:261). Over-consumption of either a common pool resource or a common property resource can lead to degradation and potentially to the *tragedy of the commons*, as advanced by Hardin (1968).

Hardin's metaphor of the *tragedy of the commons* looks into the dilemma that can accompany the use of a natural common resource. The story of herders who overharvested their pasture and destroyed their common resource illustrates how rational individuals' interest in maximizing their utility can create both a positive (and *individual*) effect and, at the same time, a negative (*collective*) effect (Hardin, 1968:1244). The condominium, by extension, is a resource that can be over-consumed and, if not protected or maintained, the negative effects will accrue to all owners and

users collectively. Hardin's metaphor, however, did not assume the existence of any rules or norms in the situation (Ostrom, 2007). In real life, herders might have kin relationships, or they may have a long, indigenous history of communal grazing and organization, or there may be formal institutions regulating management that can change and guide social behavior and common agreements to make their system sustainable. The individual incentive to maximize the return of their investment might not be the only interest involved. As Olson explained, "economic incentives are not ... the only incentives; people are sometimes also motivated by a desire to win prestige, respect, friendship, and other social and psychological objectives" (Olson, 1982:60).

Regarding the characteristics of the group, the second main contribution of Olson's work is the argument that group size can positively or negatively influence collective action. In a large group, single individual contributions to the collective good might not make perceptible differences to the group as a whole. On the contrary, lack of payment towards the collective good in a large group is more difficult to trace or notice for the rest of the group, which creates the conditions that may lead to free-riding. According to Olson, small groups can work better because monitoring and social sanctioning practices can be more direct. However, costs such as maintenance fees can be higher within smaller groups since they are spread over a smaller group of shareholders. On the one hand, sharing costs within a large group of owners might create a cost-distributive effect that could address affordability problems. On the other hand, the size of the group can create other costs, such as difficulties in decision making and with formal and social monitoring.

There is no consensus about the exact relationship between group size and its effects (Poteete & Ostrom, 2004). It is interesting to observe that the relationships might be positive or negative, depending on the institutional arrangements in place. Scholars studying condominium maintenance problems have included the variable of size in their models, generally defining it as the total number of flats in the units, as a proxy for group size (Chu et al., 2012; Ho & Gao, 2013; Orban, 2006; Soaita, 2012; Werczberger & Ginsberg, 1987). For example, Orban (2006) found that size negatively influences the cooperative potential in condominium (correlation -0.451), but the effect is small (R square .203), indicating that other variables are influencing cooperation (Orban, 2006).

Other scholars acknowledge that size might not have a strong effect. Therefore they do not include it in their models, since other institutional variables can be just as important (Choe, 1992; Yau, 2012, 2014). For Ostrom, group size is not a definite condition for collective action, and it is not the only group characteristic that needs attention. Size can also be related to the physical characteristics of the common property that has to be maintained. There is a difference in costs whether there are two

entrances or one, as noted by Werczberger and Ginsberg (2007). Whether the variable pertains to the group or the resource, size may affect the 'calculus and strategies' of individuals by making them think their contribution will actually be noticed and that it can make a difference in the collective good (Poteete & Ostrom, 2004:439-440).

A property rights regime that creates a non-excludable and rival good can lead to opportunistic behavior or the free-rider problem (Cárdenas, 2009; Olson, 1965; Ostrom, 1990). This phenomenon was touched upon earlier as occurring in condominium regimes, particularly as it affects maintenance outcomes (Chen & Webster, 2005; Chu et al., 2012; Ho & Gao, 2013; Orban, 2006; Yau, 2011). The well-known narrative of the free-rider explains the behavior of an actor who has complete information about benefits, costs, and strategies to decide on individual action: a rational actor. The rational actor will decide to take a 'free ride' on the expenses and costs of others unless he or she finds it is profitable to cooperate (Bengtsson, 1998). If the costs of collaboration do not equal its benefits, the rational actor will choose to not cooperate. If every actor decides to free-ride, then the collective benefit will not be produced. If free-riders were present, scholars would recognize a collective action dilemma:

"Collective action dilemma: a game with many actors who benefit from cooperation but find it impossible, or at least difficult, to achieve cooperation (also known as 'n-person prisoner's dilemma' and the 'tragedy of the commons') (B. Bengtsson, 2012:226)."

The collective action dilemma is the result of individual rational choice or a social dilemma. In psychology, Dawes and Messick (2000) have defined social dilemma as the 'paradoxical possibility' of individuals, a problem that has been studied in almost all the social sciences (2000:111):

"Social dilemmas are situations in which each member of a group has a clear and unambiguous incentive to make a choice that- when made by all members- provides poorer outcomes for all than they would have received if none had made the choice. Thus, by doing what seems individually reasonable and rational, people end up doing less well than they would have done if they had acted unreasonably or irrationally (Dawes & Messick, 2000:111)."

Or, as Ostrom says:

"The temptation to free-ride, however, may dominate the decision process, and thus all will end up where no one wanted to be. Alternatively, some may provide while others free-ride, leading to less than the optimal level of provision of the collective benefit (Ostrom, 1990:6)."

The theoretical assumption of rationality of actors means that individuals will always choose self-benefit (less individual cost) rather than collective benefit, even if the collective outcome is, in the long term, more beneficial to all. The rational choice is to do nothing, to not cooperate or 'to defect,' as it is called in game theory. In game theory, rational individual behavior is explained using mathematical models based on the prisoner's dilemma theorem. The prisoner's dilemma is a conflict that one player has to grapple with when choosing between what is best individually and what is best for the group as a whole.

As Ostrom (1990) explained, the prisoner's dilemma is a non-cooperative game because "communication among players is forbidden or impossible or simply irrelevant as long as it is not explicitly modeled as part of the game" (1990:4). This is a theoretical game where there is no trust; each prisoner does not trust the other to remain silent. Also, it is assumed that each player has 'complete information' about the situation, which means that each player has all the information about the full structure of the game and the payoffs. Ostrom ascribed the fascination of this theorem among social and economic scientists to the following:

"The paradox that individually rational strategies lead to collectively irrational outcomes seems to challenge a fundamental faith that rational human beings can achieve rational results (Ostrom, 1990: 5)."

For Ostrom, these models are important, but she warned about the danger of adopting them as the foundation for policy formulation (Ostrom, 1990:6). The danger lies in believing that human beings are trapped in non-collaborative rational and self-interested behavior, as if they were incapable of changing the rules, or as if humans live

in a vacuum that makes them incapable of improving their conditions in a collective without the influence of either formal or informal institutions, such as trust and social capital, which in fact exist in many communities.

Over the last few decades, these models have influenced the study of organizations, markets, and the provision of public goods (Ostrom, 1990). An enormous amount of scholarly research has been done to test the theories, both in laboratories, where it is easier to assume rationality of the participants, and in the field, where it is harder to assume rational behavior with no influence of context. In the social sciences, these models have been treated only as metaphors (Ostrom, 1990). Some scholars have criticized these theories for promoting the privatization of many important communal resources and commons, arguing that individual self-interests will fail to meet and sustain collective interests and efforts (McGinnis & Ostrom, 2014). The critics have, in fact, failed to recognize the existence of millions of instances of commons, markets, and organizations that are very much capable of sustaining and managing the collective good. Therefore, when studying groups and the collective good they do or do not achieve, instead of only studying what makes groups fail, we should also study what make groups strong and successful.

Orban (2006) explained that collective action dilemmas occur not only when consuming a good but also when providing it to a group of people (2006:13). Orban's remark reminds us that collective action dilemmas may exist alongside housing provision processes when other actors are involved in building, selling, or renting the units to low- and middle-income homeowners. Therefore, condominium common property collective action can occur at different levels of governance, thereby creating a nested system within the bounds of property law. These nested governance levels in housing institutions were explained earlier (in a previous section of this chapter).

Actors involved in building and selling are providing a common good and have different interests than future owners. On both sides, however, the external interests pertain to the same common resource. To understand how actors in the course of the housing provision phases, such as professionals (developer, lending sector, property management, and social management), are involved requires some knowledge of these external groups' characteristics and how the collective good *maintenance* is perceived by them.

To summarize, models such as the *tragedy of the commons* elucidate the suboptimal collective outcome explained by the prisoner's dilemma. In both cases the logic of the free-riding rational actor is evident when considering four characteristics of the good and the group: rivalry, excludability, size, and trust. However, the outcomes are also influenced by other institutions, such as the rules of the game. The next section of this

chapter concentrates on the solutions to collective action problems to understand the other factors that might be involved.

§ 2.2.3 Solutions to collective action problems

Olson's free-rider idea has deeply influenced the conventional wisdom about collective action with the mistaken belief that an external solution is the 'only' solution to collective action problems (Ostrom, 1990). In Olson's words, "the collective good will *not* be provided unless there is coercion or some outside inducement that will lead the members of the large group to act in their common interest" (Olson, 1965:44). His solution basically goes back to Hobbes' *Leviathan* (Orban, 2006).

Other scholars concerned with how to avoid the tragedy of the commons, particularly regarding natural resources, have advocated the development of private property systems. However, regarding the condominium private property system, Ostrom noted that "even when particular rights are unitized, quantified and salable, the resource *system* is still likely to be owned in common rather than individually" (Ostrom, 1990:13). She then asked, is there really an 'only' way to solve collective action dilemmas?

Since Olson's work of 1964, much work has shown that there are many other solutions to the free-rider problem. The development of models following the prisoner's dilemma problem in game theory have also shed light on what happens when people have different – and iterative – opportunities to develop strategies of action, which can lead to achieving collective goods.

"Instead of basing policy on the presumption that the individuals involved are helpless, I wish to learn more from the experience of individuals in field settings. Why have some efforts to solve commons problems failed, while others have succeeded? What can we learn from experience that will help stimulate the development and use of a better theory of collective action – one that will identify the key variables that can enhance or detract from the capabilities of individuals to solve problems? (Ostrom, 1990:14) "

The literature on the governance and management of commons presents a diversity of solutions to the free-rider problem. Law and formal institutions matter, and some solutions can concentrate on regulation that ensures strong monitoring and sanctions policies (Williamson, 2000). However, these are not the only options, as can be seen in condominium dilemmas, where monitoring and sanctions are already established in the property law, as particularly evident in Ecuador and Colombia. Apparently these regulations are not sufficient to enforce and ensure optimal outcomes for maintenance.

The pay-offs of some people's free-rider behavior put the community into the situation explained by game theory and the prisoner's dilemma models (Ostrom, 1990). Co-owners have fewer incentives to cooperate in governance and management of the common property if they don't see others doing so, if there are no communication pathways, or if there is insufficient information to guide individual strategies.

The first step towards finding a solution is to understand that the 'tragedy' is predictable; by implication, it is possible to manage and avoid degradation or deterioration by ensuring organization. The literature contains optimistic arguments based on evidence demonstrating that in the field, so outside the laboratories and computer models, individuals cooperate in many ways. Moreover, it has been demonstrated that the assumptions underlying the old collective action models hardly apply in the real world, such as the perfect rational individual, homogeneous groups, or the lack of institutions (Simpson, 2006; Simpson, Willer & Ridgeway, 2012). The extensive body of case studies has revealed other factors, such as the group's social norms and the processes of iterative cooperative games, that may also promote and sustain trust (Hardin, 1992; Ruttan, 2006), reciprocity (Axelrod, 1981), and ideas of collective efficacy (Kleinhans & Bolt, 2013; Yau, 2014). Interdependence, otherwise called 'mutual dependency' between actors (Bueren & Heuvelhof, 2005), also influences nonrational group behavior (Olson, 1965:43). Moreover, key physical aspects of common resources themselves are said to interact with informal institutions (Agrawal, 2001; Ostrom, 2007; Toussaint, 2011).

Understanding the institutional diversity involved in a situation is a difficult but very important process in the search for policy solutions. It requires insight into the physical characteristics of the resource, the users' attributes, and governance (rules and interaction with rules), as suggested by Ostrom (2007). Solutions that work in laboratory and model-like settings might not work in the same way in the field. The recommendation is to first diagnose the collective action problem and to start by identifying the relevant variables regarding the key action-situation of study (Ostrom, 2010). In the next section, where the focus is on housing, Ostrom's institutional framework is applied to the dilemma of affordable condominium maintenance.

§ 2.2.4 Institutional Analysis and Development (IAD) framework

The theories behind the IAD framework help explain the dilemmas of groups when they engage in cooperative behavior and shed light on how these dilemmas affect collective outcomes in different contexts, such as governments, markets, or in local situations of everyday life. The historical roots of this approach, as explained by Ostrom, include political economy (e.g., Hobbes, Montesquieu), institutional economics, public choice theory (i.e., Olson 1965), transaction costs economics (i.e., Williamson, 1965), and non-cooperative game theory (i.e., Harsanyi & Selten, 1988) (Ostrom et al., 2006:25). Institutional diversity implies that many different theories can become effective tools for explaining the different situations and policy problems present in common pool and common property resource management (Ostrom, 2005).

A framework is there to orient the analysis, but it does not necessarily need to be visible in the institutional analysis. In Ostrom's words, "it is the questions that are generated by using the framework that appear in most analyses rather than the intellectual scaffolding used by the analysis to diagnose, explain and prescribe" (Ostrom et al., 2006:25). Many of her writings use the IAD framework to analyze a set of elements that can be found in many situations. These are guidelines, and it is up to the analyst to decide which factors are necessary to explain the institutional problem of concern (Ostrom, 2009c; Poteete et al., 2010). The framework suggests observing or making assumptions about what occurs with certain elements that might be influencing the situation of study: first, what occurs in an action arena; and second, the attributes of (1) *the rules* that individuals use, (2) the attributes of the *physical world*, and (3) the nature of the *community*.

IAD set of elements in action arenas

Given the multiple levels of analysis in institutional analysis, IAD recommends selecting an *action arena*. This 'conceptual unit' is subsequently deconstructed in order to understand its structure and outcomes. The action arena has two parts: an action-situation and actors.

Action-situation "refers to the social space where individuals interact, exchange goods and services, engage in appropriation and provision activities, solve problems, or fight (among the many things that individuals do in action-situations)" (Ostrom et al., 2006:28). The action-situation has seven parts: (1) *participants*, who are in different (2) *positions*, who decide on different (3) *actions*, according to the (4) *information* they

possess and how these are (5) *linked to* potential (6) *outcomes*, considering the (7) *costs and benefits* of the actions and outcomes (Ostrom et al., 2006:29).

When studying a commons dilemma, it is necessary to understand and predict how actors will behave in an action-situation. An actor can be an individual, a group, or a corporation. In this context, the IAD framework recommends observing and making assumptions about the following four clusters of variables about actors (see Table 2.3).

(1)	Preference evaluations that actors assign to potential actions and outcomes
(2)	The way actors acquire, process, retain, and use knowledge contingencies and information
(3)	The selection criteria actors use to decide upon a particular course of action
(4)	The resources that an actor brings to a situation

TABLE 2.3 Cluster of variables explaining actors' behaviors (source: Ostrom et al., 2006:33)

Factors affecting the action arena

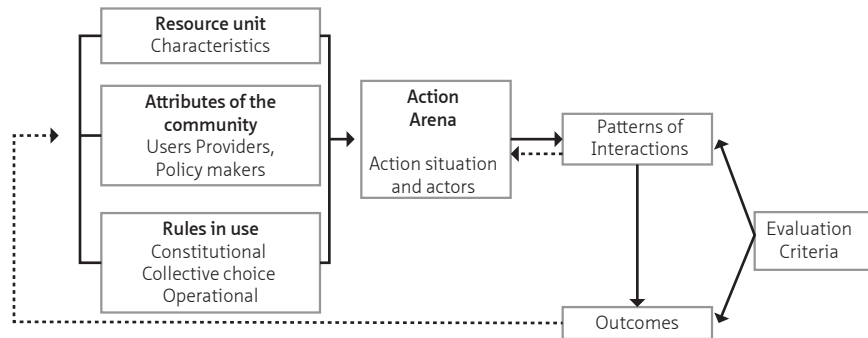


FIGURE 2.1 A framework for institutional analysis (adapted from Ostrom 2005:15. source: Poteete, Jansen, and Ostrom, 2010:41).

The IAD framework shown in Figure 2.1 assumes that there are external factors such as the rules, the resource characteristics, and the nature of the community involved that work together with the action arena. All these factors influence the way the action-situation is conceptualized and will therefore affect the outcomes. An institutional analysis should begin by understanding these factors, including the rules that apply to them: these may be constitutional rules, collective choice rules, or operational

choice rules. The physical attributes of the resource under consideration will depend on the particular common pool resource or common property resource of study and on those situations related to the action arena. As Ostrom explained, fishers' issues in the oceans are not the same as fishers' issues in the fish market. Different situations and the different physical attributes of the resource involved, such as the fish as the resource unit, the ocean as the resource system, or the market spaces, need to be specified when developing an institutional analysis.

The explanatory variables for the characteristics of the resource system, the attributes of the community, and the rules in use will be determined in light of the particular questions posed by each analyst and the different levels of analysis for the action arena under study. This thesis defines the action arena as maintenance of the common property. Maintenance is the arena in which to observe the rules of the game, payoffs, and various factors influencing actors' behavior. Both the level of policy and the co-owners' governance level are considered to interact within the action arena. In summary, the general conceptual model for the development of theories in which factors affect the maintenance of the common property resource of low-income families and why they do so is described in the following diagram (Figure 2.2):

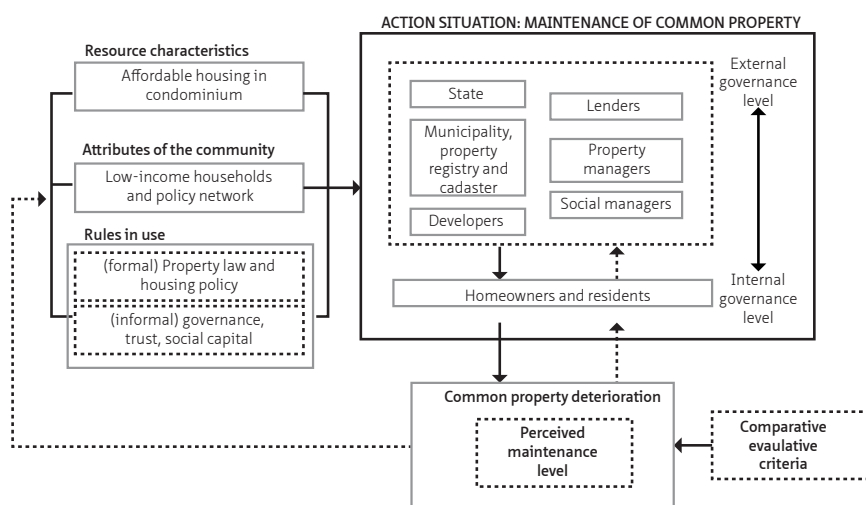


FIGURE 2.2 Conceptual framework to study affordable condominium deterioration levels. Based on Ostrom (1990)(source: Poteete, Jansen, and Ostrom, 2010:41).

Three clusters of variables representing the characteristics of the resource (affordable condominium housing), the attributes of the community, and the rules in use could all

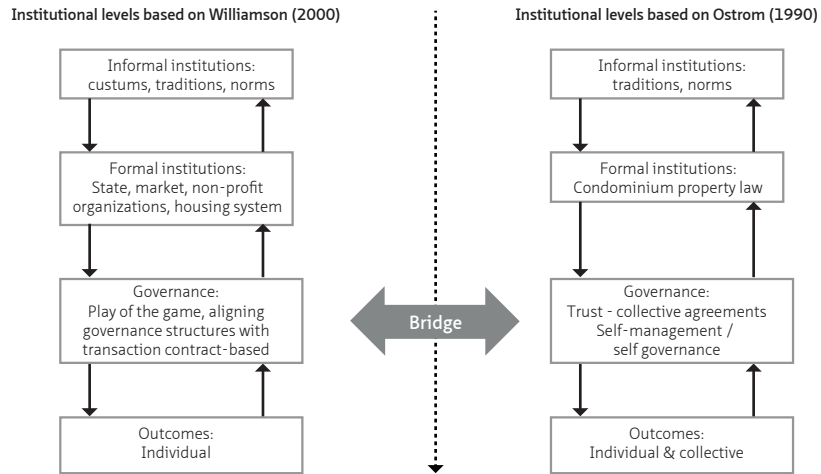
influence how the actors who are involved in the maintenance practices of the common property will behave (Ostrom, 2003:262). Actors are also participants. Each occupies a specific position from which to make decisions, based on the available information, which are linked to potential outcomes (Ostrom et al., 2006:27-37). The outcome of interest here is the maintenance level as perceived by policymakers, housing provision actors, and residents in affordable condominium housing.

Each city has its own institutional context, and this particular set of institutions will be expected to yield different outcomes in the provision and maintenance of low-income condominiums. In order to compare and explain the differences that will be observed in each city, a series of hypotheses has been developed. Since the law in Colombia has been updated more than that of Ecuador, all hypotheses will pertain to the Colombian context and outcomes, which will form the reference for comparison.

§ 2.3 Housing institutions as collective action

This last section sums up the theories presented in this chapter from the perspective of the institutional approach that guides this study (see Figure 2.3). The goal of this approach is to understand the different institutional levels in condominium. Collective action is necessary in order to keep the common property well maintained (Orban, 2006; Ostrom, 1990; Yau, 2014). From the perspective of comparative housing systems, collective action is seen in the relationship between professional housing providers and housing consumers. Both sectors need to cooperate in the phases of housing provision, wherein every actor has a specific goal and interest, be it building or buying the dwelling.

For the professionals involved in the production and transaction of housing, condominium regulations are critical, as these steer the process of provision. At this point in the development process, rules are designed for the future condominium property. This is a top-down institutional solution in the condominium regime, and a collective action solution as promulgated by Williamson (2000). The bundles of rights in condominium determine the rights and duties of the residents. Moreover, the rights invest them with the power of self-management and self-governance. The right to change the rules is the main collective right. In Ostrom's (1990) view, this is one of the most important principles in governance of the common property: the collective power to modify rules either by establishing other formal rules or by developing informal ones.



Condominium institutions

FIGURE 2.3 Institutional levels in condominium tenure

When the researcher selects and compares different low-income condominiums, the goal is twofold: to understand how the institutions of the condominium form of tenure differ from each other; and to ascertain whether one law in one context actually makes a difference by comparing it with the other context that has a different law. Initially, the research will focus on the formal institutions that constitute the bundle of rights of the actors involved in condominium ownership, such as the property law and how actors interpret and use it.

The fact that the bundle of rights can be observed among homeowners does not necessarily mean that the study has to be targeted to the selfish rational individual. Rather, it can look at residents in light of the boundaries within which they operate. These boundaries are based either on trust and knowledge about each other (informal institutions), or on compliance with the law (formal institutions). Therefore, this thesis studies governance from two angles: the Ostrom approach and the Williamson approach.

Both top-down and bottom-up institutional solutions for governance can be found in condominium. The law is the top-down agreement that households accept when buying a house or an apartment in condominium property. But are the rules clear about maintenance? What do people think about aspects of the top-down solution such as the regulations set forth in the property law? Do they acknowledge these regulations, and do these regulations play a role in the maintenance outcomes? The use of Ostrom’s framework recognizes the role of collective arrangements that are

informally developed -- for instance, trust, leadership, and learning processes within governance structures -- as key variables that might influence collective actions. In the present research such informal arrangements are important since the study is about people's homes; a home is a locus of emotional and social ties among members of the household and with neighbors.

This thesis explores top-down solutions in part I and bottom-up initiatives in part II. The next chapter presents the research design according to the phases of institutional analysis in this PhD project. For each phase of the analysis, the data and methodology used is explained.

3 Research design and methods

§ 3.1 Introduction

This thesis examines condominiums in Colombia and Ecuador, particularly those facilitated by state-led policies for low-income homeownership. As explained in the preceding chapters, comparing two similar markets for low-income homeowners under different property laws makes it possible to distinguish the effects of these institutions on maintenance outcomes. However, since the housing stock in both markets shows signs of deterioration, a comparative research design offers the advantage of pursuing hypotheses amenable to both qualitative and quantitative methods (Oxley, 2001). This chapter focuses on the methods applied in the present study to collect and analyze the data. The research design of this thesis was developed by integrating two established frameworks. One is the comparative housing system perspective (Boelhouwer & van der Heijden, 1993b; Doling, 1997; Oxley, 2001), which is grounded in institutional concepts of tenure (Elsinga, 2005; Ruonavaara, 1993). The other is the perspective recommended by Ostrom (1990, 2007), which studies outcomes by looking at the effects that these might have on (1) the characteristics of the households and community, (2) the physical characteristics of the housing complex, including the common property parts and individual units, and (3) the governance system (law and network of actors).

The research project was rolled out in three stages, reflecting the multilevel character of the phenomena of interest, from the macro (policy and law) to the micro level (policy actors and low-income households). First, the focus was on the policy setting and the historical housing context. In a second stage, the focus was on the comparative analysis of the formal institutions such as the property law. In the third stage, the focus shifted to the actors and their perceptions. Attention to the behavior of actors incorporates the informal institutions within the policy network and enacted by the households in the system. Table 3.1 below lists the methods used to collect data and to analyze each of the hypotheses at each of the three stages. This chapter briefly explains the methods applied in stage 1 and 2 and then concentrates on the methods for stage 3: the design of focus groups with policymaking and professional stakeholders and the quantitative survey of households. Before proceeding with that explanation, though, it is necessary to describe the design of the survey and introduce the cases selected for comparison.

Research design	Method	Data	Comparative analysis
Main hypothesis: The more modern property law in Colombia has a positive impact on self-organization and in turn on the perceived maintenance level			
Part II			
Formal Institutions			
Chapter 4	Housing market and policy Hypothesis: Deterioration paths seen in the privately owned affordable housing complexes is disregarded in the available market and policy data	Qualitative & Quantitative	Literature and policy reports Census data and collection of new data from cadaster Subsidy policy results and interviews with key stakeholders
Chapter 5	Condominium law Questions: Who and what are regulated by the horizontal property law? How does the regulatory system in condominiums operate? What are the similarities and differences between Colombia and Ecuador's horizontal property laws?	Qualitative	Horizontal property law of Colombia and Ecuador References on socio-legal analysis
Part III			
Informal Institutions & Governance			
Chapter 6	Network of professionals Questions: How do the professionals perceive the maintenance problem? How do they deal with it? How do they perceive the role of the law?	Qualitative	Focus groups to collect policy actors' and professionals' perspectives on interdependency and maintenance problems
Chapter 7	Governance of low-income homeowners Questions: Which factors involved in the affordable condominium system are related to the perceived maintenance level (PML) of the common property? Do these factors differ between Bogota and Quito?	Quantitative	Household survey, sample from selected condominium cases in each city
Conclusion	Condominium housing institutions: collective action Responding to the main hypothesis: do laws make a difference with respect to maintenance outcomes?		

TABLE 3.1 Research design

Section 3.2 describes the collection and analysis of policy and housing market data from both cities. Section 3.3 presents the methods applied to compare the horizontal

property laws of each country. Section 3.4 introduces the design and analysis of focus groups conducted in Quito and Bogota. Section 3.5 narrates and describes the selection of condominium housing complexes as cases. Section 3.6 explains the survey sample and questionnaire design and presents the statistical model. Finally, section 3.7 reflects on existing data and methods, considering the reliability of that body of research and how replicable it may be in other contexts.

Networks in housing provision

As set forth in the introduction to this chapter, the actors' perceptions are studied at two regulatory levels to simplify the researcher's task; the focus is narrowed to two levels of governance. One is the policy network, which comprises the actors engaged in housing provision during the policy implementation process (developers, the lending sector, the state). The other is the internal level, or the households' institutional arrangements regarding their common property and relevant external actors. At both levels formal and informal institutions are integrated in a housing system approach to reveal the mechanisms through which institutions shape the parameters of choice (Nee & Ingram, 1998:19).

"Specifying the mechanisms through which institutions shape the parameters of choice is important to an adequate sociological understanding of economic action. These social mechanisms, we argue, involve processes that are built into ongoing social relationships - the domain of network analysis in sociology (Nee & Ingram, 1998:19)."

Understanding how the external and the internal network cooperate to achieve a collective outcome is therefore critical from the housing system perspective. From the literature, one suggested pathway to cooperation is to adjust perceptions, "which can create a common ground for collective decision making and joint action" (Termeer & Koppenjan, 1997:97). Managing complex networks, particularly those pursuing public policy, is an important task for government (Kickert, Klijn & Koppenjan, 1997). In a policy network environment, relationships are based on interdependence of resources, whereby actors have to cooperate with each other to access these resources and achieve particular and policy goals (Bruijn & Ten Heuvelhof, 2000; Bortel, van, 2009). Interdependent relationships exist, though "not necessarily based on equity, between public, private and civil society actors" (Klijn and Skelcher, 2007: 587). Asymmetry in

interdependent relationships between actors should be considered in a governance network analysis, because one has to be aware that actors do not have equal power and resources. In the condominium, for instance, developers might have land but need buyers, and the latter are low-income owners that will pay for and assume property rights.

Policy networks are not always transparent and can become ‘impenetrable structures of interest,’ which, as Kickert et al. (1997) note, “can prevent necessary innovations in public policy and form a threat to the effectiveness, efficiency and democratic legitimization of the public sector” (Kickert et al. 1997:9, citing Marsh & Rhodes 1992:249-68). Actors in the policy network can encounter the same kind of cooperation problems as those experienced by homeowners inside the communities. The policy network approach is used to explain the perceptions and positions of the external actors regarding the problems that low-income owners have with maintaining the common property (chapter 5).

The next section reviews the literature on institutions of homeownership in order to shed light on the meaning of the institutions studied in this thesis. According to Giddens (1979), “as expressed in forms of life, institutions are analysed only in so far as they form a consensual backdrop against which action is negotiated and its meanings formed” (Giddens, 1979:50). Institutions become observable when actors assign meanings and interpret their role as homeowners. Generally these meanings express the idea of a homeowner in single-family ownership. However, it will be interesting to trace how these meanings and the institutions surrounding them may or may not change when observing the actors’ behavior in condominium ownership.

§ 3.2 Collection of policy and housing market data

For the policy and housing market aspects of this research, descriptive statistics from census and cadaster data complement the narrative of policy approaches in both countries. The analysis of this data is presented in chapter 4.

The goal in this stage was twofold: to show the centrality of low-income homeownership in the housing policy history; and to demonstrate that available statistics used for policy analysis are not sufficient to analyze the extent of the deterioration problems of common property in the condominium regime. First, quantitative data was collected to describe and compare the path of housing policy by

looking at some of the generally documented outcomes, such as the total number of dwellings and subsidies given to families. Then census data was collected, specifically on housing markets in Bogota and Quito. Third, cadaster data was retrieved to track the growth of the condominium housing sector since the 1960s. Despite the importance of the currently available data for both policy and housing analysis, at this stage of the research it was only useful to sketch the context in which the housing market research was conducted.

For the historical overview of housing policy, secondary sources were used, namely statistics published in the literature and in official public documents. An effort was made to concentrate on data that gives an impression of the policy outcomes achieved at the city level, both in Bogota and Quito. This data is better understood when it is juxtaposed with census data in order to analyze the growth of homeownership in both countries.

Census information about tenure focuses on *types* of occupation rather than *forms* of tenure. While this data provides a general description of the market, it cannot be filtered regarding the condominium form of tenure. In both countries, the census specifies types of occupation, including categories such as owner-occupancy, renting, and other (i.e., prisons, convents). In condominiums the units may be occupied by both renters and owners. Therefore, it would be useful to designate condominium as a distinct category, as this would allow researchers to assess another institutional level, one that intersects the standard classification in terms of tenure forms and types of occupation.

Condominium is a form of tenure and not a housing type (Rosen & Walks, 2013). Since condominium tenure is not captured by the survey's categories of the types of tenure, it is not possible to do cross analyses of housing typology by condominium tenure. The housing typology in the censuses of both countries is 'single-family', 'apartment', or 'other', the last including local categories such as *ranchos* or *covachas*.⁸ Apartments may or may not be classified under condominium tenure. Single-family detached houses may be on single lots in real individual property or within a gated community that can be subdivided under a condominium regime. Single-family attached dwellings, or rowhouses, if individually owned, probably will be under condominium tenure since the structure and land are shared. Therefore, census categories miss the opportunity to capture information about condominium housing conditions. In terms of form of tenure, the occupants of condominium housing may be owners and renters, whereas in terms of housing type, condominiums can be multi-family as well as single-family.

Census data can also shed light on the quality of the built housing stock. However, the census usually concentrates on the quality of the individual units that are occupied rather than on the common property elements shared by different owners simultaneously. Although there are drawbacks to the available census data, chapter 4 describes the market using the last census of housing in Colombia, which was conducted in 2005, with another intermediate survey done in 2007. In Ecuador, the last census of housing and population dates back to 2010.

Due to the lack of sufficient census and housing survey data for both case-study contexts, it was necessary to search for other sources. Housing policy data on the total number of families that have received a subsidy to purchase a low-cost dwelling is readily available. However, that information is not very useful for the current research purposes, since it does not give any details about whether the purchased unit is under condominium tenure or in a single-family house. Subsidy data distinguishes between urban and rural housing subsidies but not between categories of housing type or tenure form. It is possible to find out how many individual units have been built, but not how many complexes in co-ownership have been developed since the 1960s.

To find out how many housing units there are in condominium within the housing market of each city, data was requested from municipal cadaster departments in both Bogota and Quito. They provided a general list of units in condominium that had been built and registered until the summer of 2011. That list is merely an indication of the number of individual units and does not distinguish shared ownership. Still, this is primary data that can be used to show both the growth in and total market share of residential units under the condominium regime in the Bogota and Quito housing markets.

It turned out to be difficult to draw a sample from the whole population of middle-income and low-income condominiums built under the affordable housing policy in the main cities and to assess the physical conditions of the housing stock in common property in the cities as a whole. The research design of this project was highly influenced by the drawbacks of the existing data. A small-N household-level survey was envisioned to be able to delve into the condominium arrangements and co-owners' behavior regarding maintenance of a common property resource. Case studies in condominium ownership were selected in each city to draw the sample of households from these locations. Section 3.4 expands on the case-study selection. The strategy to design the survey is explained in sections 3.4 and 3.5 of this chapter.

§ 3.3 Comparative analysis of condominium property laws

The comparison concentrates on the current laws of the condominium regime, or horizontal property laws, as they are called in the Latin American region. The Colombian Horizontal Property Law was first adopted in 1948, but the current version is Law 675 of 2001. In Ecuador, the current law was adopted in 1960, with its regulatory law (*Reglamento Ley*) enacted in 1995 and 1998. Some articles of the law of 1960 were modified in 2011. The regulatory law has also been amended at different times, sometimes by presidential decree. Although there have been some modifications to the Ecuadorian law, the Horizontal Property Law of 1960 is still the main formal institution in effect for the condominium regime.

As explained in the previous chapter, the property law scrutinized in this analysis is the central formal institution governing the common property resource. It is assumed that the law establishes the rules that authorize or require a particular action in exercising a property right (Schlager & Ostrom, 1992). A rule provides information, but access to information does not mean that actors will follow the rule.

The comparison takes a socio-legal perspective of the law (Blandy et al., 2006; Edelman & Suchman, 1997). Here, we treat the law as an independent variable in order to see its effects in each studied context. Who are the parties being regulated by the horizontal property law? How is the law structured? What are the similarities and differences between horizontal property laws in Colombia and Ecuador?

To answer these questions it is first necessary to understand the content of each property law from a comparative perspective. The goal of this research stage was to see who is addressed by the law and how the law regulates the bundle of rights of the common property resource. For this purpose a coding strategy was developed to analyze and compare each article of the laws. The coding was based on the conceptual framework (see chapter 2), using three levels of coding: (1) the actors and institutional arrangements, (2) the phases of housing provision, and (3) the environment of the laws. Once this analysis had been performed, it was possible to trace the different actors and their positions regarding the common property resource and its maintenance. The analysis was extensive, covering all arenas that the law regulates, but not all parts of the law pertain to the maintenance issues of the common property resource. Therefore, the analysis in chapter 5 uses the extensive analysis but focuses on those operational and constitutional rules that are relevant to the self-management and maintenance of the common property resource. The data analysis focuses on those articles that are meant to regulate maintenance actions both at the collective-choice level and operational-choice level (Ostrom, 2005).

§ 3.4 Focus groups

A focus group methodology was applied to assess the problem as it is perceived by policymakers and professionals who are involved in the implementation of low-income housing policy and low-cost housing provision. The focus groups held in Bogota and Quito in October and November of 2012 were intended as means to collect data and to observe actors interacting with each other and debating about the problem.

Focus groups are a specific type of a group interview and are often conducted in studies of governance networks in which the researcher plays an active role during the discussion (Damgaard & Sørensen, 2007:180). This type differs from in-depth and individual interviews in that it is more concerned with organizational and policy implementation issues and less with particular or personal information about the actor. The group dynamics and interaction in a focus group stimulate experts and professionals to discuss their different perspectives (Stewart & Shamdasani, 1990). It works like this: a comment from one individual often produces more ideas and new comments from others in the group. Therefore, conversation around a key topic is nourished by the synergy generated within the group (Krueger & Casey, 2009). The basic idea is that comments would emerge spontaneously following the guidance of the moderator (Fallow & Brown, 2002). The focus group method is a useful way to discover how respondents talk about a particular problem; there is no correct comment or answer and there is no need to reach agreement in the group discussion (Hennink, Hutter & Bailey, 2011).

The participants in the focus groups in Bogota and Quito belong to the external policy network, as defined in the conceptual framework of this research (see Table 3.2). These actors were identified during exploratory interviews with key stakeholders and through the analysis of policy documents and the detailed examination of the horizontal property law. The underlined actor included in the table below is one that was not mentioned in the laws of either Colombia or Ecuador but was considered to belong to the network. In the same vein, social managers were also invited to attend. This is a ‘purposive sampling’ technique that is generally applied in focus groups (Fallow & Brown, 2002:161).

To collect information, simultaneous focus groups were organized in each city as part of a workshop event. The event was planned for one Saturday morning in Quito, and it was repeated a month later in Bogota. At each event, the problem of the study and the agenda were presented in a plenary session. The purpose of the event and the simultaneous focus groups was stated and the presence of different actors from the external network was recognized by the researcher, who pointed out the importance of

the event. In a round-robin format, all participants were asked to introduce themselves and share their expectations about the discussion that the event will promote. Certain words -- such as maintenance, horizontal property law, and condominium -- were deliberately not mentioned in the invitation, introduction, and questions. It was expected that the participants would bring up these topics in their discussions and comments. The main words defining the problem of the study were the 'deterioration of the social interest housing stock'. 'Social interest housing' is the English translation of *Vivienda de Interés Social*, which in this thesis it is better called *affordable housing*. The focus groups were held in Spanish; therefore, the notes, discussion guidelines, recordings, and transcripts are also in Spanish. The planning was done both in English and Spanish, and self-recorded information on cards was translated from Spanish into English for the analysis.

EXTERNAL	INTERNAL
Ministry	Owners (individual households)
Municipality	Tenants (users by contract)
Building permit department	Developer/owner
Cadaster	Owners as collective: Assembly of owners
Property register	Board of homeowners
Notary	Property manager
Developer	
Lender	
Property manager	
Social manager	

TABLE 3.2 Actors and governance levels of governance of low-income condominium policy network (source: *Analysis of horizontal property law, empirical research*)

* Only external actors were invited to the focus group.

Invitations to attend the focus group event introduced the topic of the research, its objectives, and the agenda for the day. The letter also mentioned who else was invited so that actors might see the event as a networking opportunity and therefore as an incentive to come to the event. In Bogota, the event took place in a large meeting room of the Habitat Department of the Municipality of Bogota.⁹ In Quito, the plenary meeting

9

Secretaría del Hábitat, Alcaldía Mayor de Bogotá, thanks to Dr. Maria Mercedes Maldonado, who authorized and provided the institutional support to hold the workshop on Saturday, November 24th, 2012.

and group interviews took place in FLACSO's¹⁰ academic building. In addition to the interest and concerns shown by the participants, both the location and the institutional support from the Municipality of Bogota and FLACSO positively influenced the high response rate to the event.

In each city, 50 invitations were physically distributed by a mailman who was hired specifically to distribute and check the receipt of the invitations. The response rate and attendance at the focus group event was remarkable, with more than 50% of the invited actors confirmed in each city. In Bogota a total of 27 actors attended the focus group event, while in Quito 31 people attended. Six focus groups were simultaneously held in Quito, and then the same strategy was applied in Bogota, where it was possible to hold five simultaneous focus groups. Groups of five or six participants were invited to sit at round tables. Each table was organized to ensure heterogeneity among the actors so that different perspectives could be brought up in the discussions. Each table had at least one person representing the following actors: housing ministry, municipality, developer, property manager, nonprofit social managers, and property registry. One facilitator was assigned to each table to assist in the discussion and to record information. Considering the research funds available, and given personal experience in participatory and group discussions, the principal investigator was the moderator of the event. This fact influenced the techniques for recording information, since as researcher and moderator it was necessary to be aware of multiple aspects at the same time, and some information might have been overlooked.

Focus groups included two discussion activities, ranging from general to more specific; the first activity concerned roles and resources. In institutional and network analysis, the first step is to identify actors' positions (Poteete et al., 2010). The objective was to trace and visualize resource interdependencies and to identify the actors' main roles and how they measure outcomes (Kickert et al., 1997). The idea was to test whether the actors see themselves as 'participants' in the action-situation under study. The moment they see themselves as participants, they can see the interdependencies and the links among them. Different characteristics of the network were recorded, such as multi-formity, interdependence, and closedness (as used in van Bortel & Elsinga, 2007). Every position of a participant is associated with authorized set of actions that are linked to outcomes in the process (Ostrom et al., 2006:30). These positions can be traced by identifying their interests and the resources they possess and those that are shared (Enserink et al., 2010).

10

Facultad Latinoamericana de Ciencias Sociales, Quito, Ecuador, thanks to the support of Dr. Ramiro Rojas and Arq. Marco Cordova, assistant professors of the Public Policy and City Studies program.

The second activity was devoted to the actors' perceptions of the maintenance of low-income condominium housing. The strategy of presenting a 'vignette' was used to offer a scenario of a deteriorated housing stock. The vignette was also presented as a poster so that actors could see pictures of the deteriorated housing complex. Actors were asked to respond to three questions: (1) What went wrong? (2) What caused the deterioration? and (3) What can be done to solve the problem? This activity was designed to reveal whether actors consider themselves involved (as participants) in the action-situation under study. Moreover, it was useful to hear what the participants said about the responsibilities of other actors regarding the problem.

During both activities, information was self-recorded by the participants, who were asked to write down their thoughts and responses on colored cards, which were later hung on boards. During the second activity, those boards included a timeline of housing provision phases (production, exchange, and consumption). While responding to the three questions, participants were asked to locate the card according to the phase of housing provision pertaining to their comment. Secondly, information was captured in voice recordings. Thirdly, the facilitators, principal researcher, and moderator made field notes. Analysis of data then took into account these three sources of information, using some quotes from the transcriptions of the colored cards and the voice recordings. The systematic analysis followed the sequence of the questions, responding to the sub-questions regarding actors, institutions, and the phase in housing provision (see Table 3.3).

QUESTION	LEVEL 1	LEVEL 2	Level 3
1 What went wrong?	Are problems related to formal or informal processes; external or internal institutions?	Who is the actor mentioned or implied?	During production, exchange, or consumption?
2 What are the problems?	Are they physical or organizational (cooperation) problems? Other?	Who is the actor mentioned or implied?	During production, exchange, or consumption?
3 What are the solutions?	Are solutions formal or informal? Within external or internal existing institutions, or new ones?	Who is the actor mentioned or implied?	During production, exchange, or consumption?

TABLE 3.3 Methodology for the systematic analysis of the focus groups' second activity and posters

In light of the data in each table, it is apparent that the total number of focus groups held in each city was adequate. The information started to repeat itself, showing 'data saturation' (Hennink et al., 2011). Some of the actors who accepted the invitation and attended the focus group event had a special interest in talking about the problem.

Others were just curious about the event and saw the invitation as a networking opportunity. Therefore, it was necessary to be aware that a small amount of bias can exist in the collected data. The qualitative research and analysis methods covered in chapter 6 deal with possibly biased information by clarifying the role of each actor and his or her position in the network.

The participants are key stakeholders. Their opinions are interpreted in their contexts, and their agency in policymaking is of significance in both cities. The participants had the opportunity to evaluate the event: the course of the day, the methods, and the moderator. Overall, they rated the event as positive and useful, especially with respect to the group of people invited to the meeting.¹¹ See Appendix A for a detailed list of participants in both cities and the guidelines for the discussion, as well as a translated summary of the collected data.








Judging from observations of the principal investigator, some collective learning took place during the focus group discussions. This may have had some influence on the actors' behavior by changing how they perceived other actors' positions in the network. Transformation of perceptions and learning from others' opinions is generally expected as an immediate outcome of focus group interviews (Damgaard & Sørensen, 2007:206). The interactive aspect of a focus group helps actors to reformulate their points of view and sometimes to reconsider their own ideas about and their understanding of a topic (Fallow & Brown, 2002:159). The data from and results of this stage of the research are analyzed in chapter 6 of this thesis.

§ 3.5 Case-study selection

Four housing complexes in condominium tenure were selected in each city (Figure 3.1). The first reason to select cases was to have a sample of housing complexes in condominium from which to draw the small-N survey of households in co-ownership. The second reason was to remain consistent with Ostrom's method to understand collective action and governance of the common property (Poteete et al., 2010) and to be able to compare the phenomena between the two cities.

11

An exit questionnaire was given to all participants.

<p>Q01</p>  <p>528 units 1974</p>	<p>Q02</p>  <p>16 to 50 units 2003</p>	<p>Q03</p>  <p>74 to 120 units 2010-2014</p>	<p>Q04</p>  <p>50 to 104 units 2013</p>
<p>B01</p>  <p>960 units 1958</p>	<p>B02</p>  <p>198 units 2003</p>	<p>B03</p>  <p>83 units 2010</p>	<p>B04</p>  <p>230 units 2013</p>

State-centered provision

Subsidy-based housing policy

1980 /1990

FIGURE 3.1 Selection of case studies in Quito (Q01-Q04) and Bogota (B01-B4)

Common property resource case studies

For an institutional analysis of common property resource management, it is useful to conduct small case studies and compare them. This case-study approach offers the specific context from which to develop theories of the different relationships of the phenomena that are observed:

"Close examination of individual cases offers opportunities to develop concepts and theory, identify the limits of general relationships and disprove deterministic hypotheses, control for confounding effects through within-case comparisons, and disentangle causal processes. The case study method is especially appealing in the effort to make sense of complex processes. (Poteete et al., 2010:33)"

There are some disadvantages, as set forth in the literature, to the case study as a method in the social sciences. One issue is external validity, possibly making it difficult but feasible, to replicate the analysis. The other is confusion about what a case really is. This research is a multi-level case study: first comes the city, second the housing complexes, and third the household. However, in this chapter the qualitative and quantitative research cases are specifically the housing complexes from which (1) interviews with key internal actors were conducted and (2) a sample of households was drawn for the quantitative survey. The external validity and the possibility of replication are tied to the selection of variables. Considering the various forms that housing complexes can take, the variables selected for this research can be found in all cases, regardless of differences in architectural and urban design. Knowing that condominium tenure is a global issue, and following the literature and studies on condominium maintenance and collective action dilemmas, researchers will acknowledge that they could find and test the selected variables in other contexts too. Therefore it is plausible that the theoretical and methodological approaches underlying this thesis can be replicated in other contexts to compare the theoretical results.

	YEAR BUILT	HOUSING/LAND POLICY	DEMAND SUBSIDY	SOCIAL MANAGEMENT	DWELLINGS PER COMPLEX*	TYPOLOGY
Bogota						
B01	1958	ICT	No	Yes	752	High- and middle-rise block towers
B02	2003	Market approach	Yes	Yes**	184	Terrace dwellings
B03	2010	Ciudad USME	Yes	No	83	Middle-rise building
B04	2012	Ciudad Verde	Mixed	Yes	240	Middle-rise building
Quito						
Q01	1974	BEV-JNV	No	No	480	Middle-rise building.
Q02	2003	Vivienda Solidaria	Mixed	No	16-50	Rehabilitated historic center house
Q03	2010	Market approach	Yes	Yes**	74-120	Terrace dwellings
Q04	2012	Ciudad Bicentenario	Yes	Yes	50-104	Mixed, middle-rise building and terraced dwellings

TABLE 3.4 Controlled variables for case study selection

* In Ecuador these vary, since case selection is based on the housing program.

** Social managers were hired after problems within the community affecting the development and external actors.

This thesis applies a case-study method with qualitative and quantitative statistical analysis. Individual perceptions affect collective outcomes. Thus, there was a need to gain access to certain housing complexes where it was possible to hold in-depth interviews with key informants as well as the household survey. Both sources of

information were deemed to elucidate group behavior and agreements on managing the common resource and carrying out maintenance. A total of four cases (housing complexes) were selected in each city. These cases were chosen by controlling for the following characteristics of the resource. According to theory, these are important physical categories that can have an effect on collective outcomes of maintenance. Four attributes were taken into account for the selection of cases: (1) year of construction and type of government intervention, (2) involvement of social management in the process, (3) size, and (4) housing typology. These may be seen as conditions that ensure variation in the selection of cases among properties sharing the same condominium regime (see Table 3.4).

Government involvement and year of construction

The first controlled factor in the selected cases is government intervention. There are many housing complexes that were built throughout the several decades in which the homeownership program was implemented. How to choose among these? The selection ensures that at least one case dates from the beginning of the low-income homeownership policy and other cases are from the current period. Government involvement is what distinguishes the selected cases from other high-end condominiums in the market. Case selection by either state-led or subsidy-based policy inevitably helps to set a time variable, since the form of policy correlates with the year of construction. The age of the housing complex is important because deterioration can depend on how old the materials used in the buildings and units are. A general hypothesis would be that the older the case, the more deteriorated it will be, unless other factors play a more important role.

The first housing complexes built both in Quito and Bogota are iconic buildings due to the novelty of state-led provision at the time. One case representing the first generation of middle-income and low-income housing in condominium was chosen in each city: the Urban Center Antonio Nariño in Bogota (1958) and Condominiums Luluncoto in Quito (1974). The next three selected cases in each city belong to a more recent period, the decades after the 1990s, when the policy was liberalized and the subsidy implemented.

In Quito, one of the first housing programs that was built in collaboration with the municipality was *Vivienda Solidaria* (Q02), whereby low- and middle-income families were able to purchase dwellings with a down-payment subsidy. The program got started in the historic center of Quito in the late 1990s and ended in 2003 when people moved into the new dwellings. The selection was intended to ensure a similar age of cases. Accordingly, a housing development built in 2003 in Bogota was chosen

to make it comparable to Q02 in terms of year of construction. The second selected case in Bogota, *Alameda del Parque* (B02), is the first affordable housing project built by a private developer. It is a project of single-family houses in condominium tenure purchased with subsidy. The particular aspect of this project is the involvement of social managers.

Next, two projects built in 2010 were selected in Quito and Bogota. In Quito, case Q03, *Alba Azul*, was completed with the collaboration of many actors, including a nonprofit organization as the main lender, a private developer in charge of construction and sales, and the housing ministry as the subsidy provider. In Bogota, case B03 is a five-story building located in USME, an urban area in the southern part of Bogota's capital district. This affordable housing property was built by a private developer.

In addition to the subsidy policy, many affordable housing projects were developed together with land policies and programs resorting under the municipalities and intended to provide affordable land for social interest housing. This is the policy context for cases Q04 in Quito and B04 in Bogota. To make affordable housing possible, the municipalities played a key role in both the urban design and development of a large housing development project. Urban blocks would then be given or sold to private developers, who would build the homes. Q04, *Ciudad Bicentenario*, is located in the very north of Quito Metropolitan District, and B04, *Ciudad Verde*, is a new town that was built to provide affordable housing on the periphery of Bogota. It was among these big developments that some housing complexes were chosen for the investigation.

Involvement of social managers (Acompañamiento social)

During the first year of research, social managers were identified as actors in the system. Social managers are professionals with training in social work and social psychology. Their role is to assist the developer (of either private or public agency) handle relationships with the community of the future homeowners. For instance, social managers organize information meetings about the tenure form of condominium. They also bring together the community by helping its members identify leaders and assisting with the constitution of the board of homeowners and other institutional arrangements required by law. Each social manager has a different method and approach to the communities. Their work ranges from facilitating two or three informative meetings to organizing sustained work with the community during the process of provision. Regardless of their method, the role of the social manager is temporary.

Formal actors would be those that come to the action-situation because they are authorized participants according to the rules of the game; among them is the property manager. By contrast, an informal actor is someone who participates in the action-situation (maintenance) even though the contribution of that actor is not mentioned in the laws and policies. The role of social manager is rather informal. There is no explicit policy that requires the involvement of social managers in the housing provision process in Colombia and Ecuador. Nor are there any guidelines or policies regulating their involvement with the collective rights and obligations of homeowners. Although not explicitly mentioned in the regulatory frameworks, their role appears to be important.

During the research, social management was observed in just a few projects, and some differences in its implementation were noted between Bogota and Quito. Thus, the cases in each city were selected to ensure that the sample has some projects with social management during the provision phases and others that function without it. The social manager is an outsider who can influence what occurs among the homeowners. Chapter 6 expands on the role of the social manager; in chapter 7 this actor is included as a dummy variable to consider the effects of such involvement on the statistical analysis. Social managers can be private social entrepreneurs or they can be public actors, resorting under municipal housing departments or the housing ministry. Table 3.1, which shows a list of the selected cases, has a column showing whether intervention by social managers has occurred.

Size and housing typology

Size, both of the group and the resource, is an important variable in collective action theory, so it had to be taken into account when selecting the cases. A variable to control for when selecting housing complexes was the total number of dwellings they comprised. Here it was necessary to be consistent with previous research on condominiums, which defines the size of the resource as the total number of dwellings (Werczberger & Ginsberg, 1987; Yau, 2011). Therefore, when selecting cases for this study, care was taken to choose complexes that did not all have the same number of dwellings.

The case selection naturally differentiates by location and typology, although the controlled factors are mainly tied to the housing program and, therefore, to the year of construction. By definition, cases from the period when government acted as builder are more centrally located than those built in 2012. Multi-family structures can take the form of a mid-rise building, a group of townhouses, detached dwellings, or a combination of these. The effect of typology, however, will be analyzed in a descriptive

format, including diagrams to clarify what the common property of each housing complex is. The common property resource needs maintenance, and it must be clear what those common elements are. In summary, the number of dwellings is deemed to be an appropriate variable, as it is easily comparable and amenable to this particular research design.

The definitive selection of cases involved a careful process of ensuring that some conditions were met, including being able to access and survey the owners living in the housing complexes. Certain cases had to be eliminated because some of the conditions were not met, and the goal of the selection procedure was to ensure both comparability across the cases and access to the complexes. Although some complexes were evidently heading towards physical deterioration of the common property elements, it was not always possible to access information about this impending problem. In some instances there was no working board of homeowners; in others it proved difficult to find homeowners willing to initiate contact with the research project. Other complexes had obvious problems with security or were located within distressed areas, making it difficult or even dangerous for a single researcher to perform fieldwork. Therefore, the definitive selection of cases might not include the most deteriorated or problematic housing complexes from each city. As Ostrom would say, researching failure in collective action is sometimes more difficult than researching success, but we can learn lessons from both (Poteete et al., 2010).

The following section includes a brief description of the selected cases in Bogota and Quito. In each case the investigator was able to interview both the president of the board of homeowners and the person who acts as the property manager. In Quito, these two roles are sometimes performed by the same person. Each case is introduced by describing a particular aspect of its history and identifying who was involved in the building and sales process. Then, using qualitative data from the interviews and pictures and diagrams about the property, the description includes some details about the physical configuration, typology, and size of the common property. Third, the narrative concentrates on how the particular community manages the institutional arrangements regarding maintenance issues. Data about the attributes of the community of homeowners and how they evaluate their maintenance of the common property is presented and analyzed in chapter 7.

§ 3.6 Quantitative survey

The survey was deemed an appropriate means to elucidate how a sample of co-owners perceive maintenance levels of their common property and identify the factors related to these perceptions. More details on the survey questionnaire and statistical analysis are included in Chapter 7. To investigate the factors that influence households' collective action, the study used the IAD framework (Ostrom, 1990, 2007) as a model to select the main variables of interest: (i) attributes of the community, (ii) attributes of the physical resource, and (iii) governance system. This section first explains the sample design and fieldwork, then it presents the questions and variables used in the analysis, and finally it outlines the quantitative methods applied in the analyses.

§ 3.6.1 Sample design and fieldwork

The small-N sample design took into consideration both the case-study characteristics and the comparative approach. In view of the multi-level approach of the research and the limitations on the budget, access to dwellings, and time to perform the data collection, a random sample of 50 households from each of the four selected housing complexes was drawn. Therefore, considering that the case sizes (total number of dwellings in shared property) are different, the goal was to survey 200 households in Bogota and 200 households in Quito, thereby ensuring a balanced sample of households per case and per city for the sake of comparability.

Both the postal and telephone survey options were rejected because of local conditions and the difficulty of obtaining both postal addresses and phone numbers. To ensure a high response rate, the fieldwork plan and questionnaire were designed as an interviewer-administered survey, to be completed after ringing the doorbell of random units within each selected case. Trained interviewers were hired to administer the interviews, and an interviewer supervisor was also employed.¹² To be able to access the common property, authorization was solicited from the board of homeowners

12 CENAC was contracted to assist with the interviewing process in Bogota, where a team of six interviewers with a supervisor worked for four weekends to complete the expected sample. In Quito, a team of six interviewers and supervisors worked during four consecutive weekends. In both cities interviewers were given a one-day workshop and training to familiarize them with the questionnaire and let them practice how to introduce the purpose of the research and themselves.

and/or the property manager in charge.¹³ This made it likely that we could get a high response rate. Table 3.5 shows the total number of interviews per housing complex that was achieved. The goal was reached by collecting data from a total N universe of 414 households, being 200 from Bogota's cases and 214 from Quito's cases, creating a nested sample of household information.

Cities (2)	BOGOTA				QUITO			
Cases (8)	B01	B02	B03	B04	Q01	Q02	Q03	Q04
Households samples	54	50	46	50	56	52	50	56
Total (N = 414)	n = 200				n = 214			

TABLE 3.5 Surveyed nested sample of households in Bogota and Quito

The pilot questionnaire was first tested in both cities and then adjusted accordingly. Some terminology was adapted, since the laws and the communities use different wording for key concepts, including the 'board of homeowners'. In Bogota, the board is called a council but in Ecuador a central committee or *directiva*. The interviewer-administered questionnaire took about 30 to 40 minutes to complete with each head of household, and a team of six interviewers surveyed 50 households from one housing complex on a weekend day. In general, the fieldwork consisted of one month in Bogota and one month in Quito. Since a flyer was distributed a couple of days before the interviewers knocked on doors, people were already familiar with the survey, and this facilitated the self-introduction of the interviewer. The flyer or invitation to participate in the survey was addressed to both tenants and owner-occupiers.

The following section describes the nested-level approach and identifies the variables. The households in the sample are not independent from the context to which they belong. Households coming from each case (B01, B02...B04; Q01, Q02...Q04) are dependent on their common property resource. Both Bogota and Quito are macro-level units in the sample, each subject to a different legal context due to the property laws. Households are at the micro level where the dependent variable is defined.

13

Only common properties from which authorization was received from their board or property manager were surveyed.

§ 3.6.2 Multiple variables and statistical methods

The sample is structured hierarchically: a sample of households within a case and within a city. There is one single outcome that is measured at the lowest level: individual perception of maintenance level (PML). According to Ostrom's theory and model, the characteristics of the resource and the governance system (formal rules) might have an influence on both individual and collective outcomes. The perceived maintenance level (PML) becomes the main dependent variable as the key outcome of the action-situation of study.

How the PML score varies depends on the households, the case (resource attributes), or the city (different property law). The variance needs to be explained with a multivariate statistical model, which is basically a hierarchical system of regression equations. The univariate relationship between each variable is explored by a general linear model controlling for the city in order to discern comparative effects. Only statistically significant variables will be included in a regression controlling for factors regarding the common property attributes and legal context. However, for the final model two different regressions will be developed, and the results will be carefully evaluated in light of the sample design.

Dependent variable: Perceived maintenance level

Maintenance entails processes and actions targeted to manage the use and deterioration processes of the physical elements of a building. How acceptable is the maintenance level of a property? The answer to this question is given by the owner and the user of the building and its common physical parts (Lowry, 2002; Mossel, 2008; Straub, 2002).

The survey questionnaire used for the case studies in Bogota and Quito did not imply any particular problem with maintenance. The assessment of the maintenance level was left to the residents themselves. The questionnaire allowed each household to provide any information about problems by answering yes/no and open questions. Each was also asked to grade the maintenance level of ten selected common property elements, from which a score was calculated. Ten elements shown in Table 3.6 represent the three main common property components covered in the questionnaire: (1) land, (2) structure, and (3) infrastructure. In the present study, three common elements were measured that belong to the category of land: the gardens, walkways, and parking areas. There are five elements that belong to the category of structure: entrance, facades, stairs, roofs, and the common room where assembly meetings can be held. Lastly, there are two elements that fall into the category of infrastructure: water pipes and lighting in public/private areas.

Other elements of the common good such as service equipment (elevators, water pumps, office supplies) were not included in the questionnaire because these elements require more technical assessment; furthermore, not all buildings in condominium have elevators or water pumps. The methods and questionnaire design had to ensure the compatibility of the results. Information about elements that require more technical assessment was collected in the interviews with the president of the board of homeowners or with the property manager.

Common property category	Physical elements
Land	Gardens, walkways, and parking areas
Structure	Entrance, facades, stairs, roofs, and the common room where assembly meetings can be held
Infrastructure	Water pipes and lighting in public/private areas

TABLE 3.6 Three main common property elements and the selected

There are many common elements of a building in condominium for which the maintenance can be assessed separately. The ones that were chosen are clearly elements that households can easily recognize and grade as to their own perceived level of maintenance. In the literature, Werczberger and Ginsberg evaluated maintenance by observing the upkeep of the entrances of buildings, looking at the doors, staircases, and mailboxes (Werczberger & Ginsberg, 1987). However, theirs was an external evaluation made by the researchers themselves.

In another study, Orban was able to use a survey that had been conducted by government where the general condition of the building was assessed, including the quality of the surroundings.¹⁴ Orban applied a factor analysis to choose variables to determine building condition, but the dependent variable was the cooperative potential. Therefore, she estimated the probability of the effect of rundown conditions on the surroundings but did not take household evaluation of the common property into account (Orban, 2006). Soaita (2012), studying Rumanian condominiums, made a ranked-priorities table for repair and renovation of the residential block, such as pipe renewal, staircase painting, exteriors, roofing, and upkeep of green areas (Soaita, 2012:1021). That study, also presented descriptive statistics linking these results with qualitative data.

14

Six factors: police factor, rundown and dirty house factor, reconstruction factor, shabby surroundings factor, development factor, and industrial factor. All these factors explained 63% of the total variance in a logistic regression of participation rate (0=participation rate under 50% and 1=participation rate above 50%).

The diversity in the physical characteristics and the architectural design of housing blocks and complexes in condominium make the assessment of the maintenance level of the common property resource a challenge. It becomes even more difficult when the purpose is to compare the outcomes in two different countries. Therefore, this study developed a measure that follows the standard definition of common property in condominium for this study: land, structure, and infrastructure as latent variables. These three elements will always be found in common property irrespective of the context of analysis.¹⁵ In the survey (question 18)¹⁶ the head of household that was interviewed was asked to grade maintenance level of each individual element of the three main categories: well maintained, maintained and not maintained. An option of does not apply to that building was also included. Responses from each of the ten elements were recoded to build a score of over 30 points. A higher score towards 30 means a higher level of perceived level of maintenance.

Independent variables

Each variable that corresponds to the attributes of the community, governance, or resource characteristics will enter the model only if after performing a bivariate analysis it shows a statistically association with the perceived maintenance level (PML). Association is measured using correlation analysis when variables are continuous and using ANOVA when the measurement is categorical. To test the between-subject effects within the two cities, a general linear model is used in SPSS, analyzing each variable in relationship to the PML and the city. With this test it is possible to observe when a variable is significantly associated with the PML in one city but not in the other, or in both. Moreover, knowing the independent effect without controlling for other variables first helps to see more clearly how the effect changes once other case-level or city-level factors are controlled and not assumed as constant.

The attributes of the community imply latent variables such as socioeconomic characteristics, history of use, and also trust and social capital as suggested levels included in the theory of the commons. The second-tier level is defined by the researcher and is measured in the questionnaire. Trust and social capital are both informal institutions and are included in the model in order to test their effect on the

15 Other high-end condominium developments will have common swimming pool areas and many other facilities or amenities that are not found in the selected cases of study. Affordable housing projects have the most basic common areas possible; these are not luxury complexes or condos.

16 Questionnaire included in the appendix.

outcomes. Question 39 of the questionnaire for instance asks: How much trust do you have that the money that people pay for the maintenance fee is well administered? And question 52 asks: How much trust does the Management Council/Board of homeowners inspire?

Governance system variables regard both the household level and the case level, such as the dummy variable involvement of 'social management'. The independent variables in the third block correspond to those that measure the attributes of the physical common property. Data entry and preparation (recoding) was necessary in order to start the comparative, multi-level analysis of the different effects in each city regarding the maintenance outcome.

§ 3.7 **Mixed-method approach**

Combining qualitative and quantitative methods (Brannen, 2005; Glaser & Strauss, 1967; Greene, Caracelli & Graham, 1989; Guest, 2012), is a scientific research strategy implying a cycle that includes the contextualization and the findings of qualitative research stages developed at the beginning of the research project, which is significant for the design, validation, and interpretation of the quantitative stage (Brannen, 2005; Hennink et al., 2011). The survey and quantitative analysis at the end helps to test both contextual and theoretical hypotheses and to develop theories for maintenance issues in common property resources.

Case selection in this thesis not only provides a basis for drawing a sample of households in common property but also shows the variability of affordable condominium housing in the market. The variability of physical resource attributes among the cases presents a challenge to the effort to understand the problems that arise in a condominium regime. This study shows how these constraints can be addressed in a larger-scale survey. However, the combination of qualitative and quantitative research is a critical methodological decision, as it allows us to interpret the quantitative results.

Consecutive field research for data collection that involved traveling to both Bogota and Quito was done in 2011, 2012, and 2014. Data was collected through (1) interviews (May-July 2011), (2) focus groups (October-November 2012), and (3) case-household surveys (February-March 2014). After each fieldwork period, data was analyzed in the Netherlands. When data is not available and accessible, it is necessary to collect it,

which requires careful planning and dedicated research funds. Fieldwork is intensive, and data takes a considerable amount of time to process. The research design in the first stages informed the subsequent second and third phases of the research. Therefore, it may be concluded that the research design proved successful and can be replicated in other contexts.

Part II

This part is devoted to formal institutions.

The housing market and the subsidy policies promoting homeownership are covered in chapter 4. An analysis of the property law of each country is presented in chapter 5.

4 Housing market and affordable housing policy

§ 4.1 Introduction

The first step in the comparative analysis is to examine the data on housing markets and subsidy policy. The underlying hypothesis is that those sources ignore the path of deterioration seen in privately owned affordable housing complexes.

This hypothesis challenges the idea that it is possible to analyze condominium deterioration processes with conventional quantitative methods of policy analysis. Does the available data reveal how many condominiums exist in the housing sector? What can we know about the deterioration process? Section 3.2 of the preceding chapter described the data on which this comparative analysis is based and explained its limitations with respect to the low-income condominium housing stock.

Condominiums were initially developed in both Colombia and Ecuador with the support of housing policies for low-income homeownership. Condominiums, or 'condos', are buildings in multi-owned structures (Blandy et al., 2010) that constituted a new form of home ownership in capital cities such as Bogota and Quito. Condos were first built when both populations and housing needs were rising. The governments decided to create public, national institutions to mass-produce affordable housing in multi-family buildings (Ballen, 2009; Montoya, 2004). Development began in 1958 in Bogota and in 1960 in Quito after the adoption of the horizontal property laws in each country. Those years establish a point of departure for the housing policy and market analysis that is the subject of this chapter.

This chapter concentrates on the comparative analysis of housing markets and incentive-based policy for low-income homeownership in Bogota and Quito, and it is divided into three parts. Section 4.2 explains, from a historical perspective, how housing policies in both Colombia and Ecuador were adopted under the constitutional housing rights and how the role of government has changed. Section 4.3 treats Colombia's policies and Bogota's housing market data with a particular emphasis on the incentive-based policy for low-income homeownership. Section 4.4 treats

Ecuadorian policies and Quito's housing market data and describes the incentive-based policy as it is applied in Quito. Section 4.5 summarizes the findings from the comparative analysis, accentuating the similarities and differences between the housing markets of Bogota and Quito.

§ 4.2 Housing policy in historical perspective in Colombia and Ecuador

Latin American housing markets have both formal and informal housing sectors; for each there are specific policies and programs, which are funded and developed by the national governments (Blanco, Cibils & Muñoz, 2014; UN-HABITAT, 2010). The formal housing market comprises housing that is generally mass-produced and that has building permits and property titles; the informal market occurs outside the bounds of the legal systems and prescribed patterns of urban development. Informal housing includes dwellings that are self-built over time without participation of the construction companies and investors that are typically involved in the formal housing market. It is common for homeownership and renting to coexist within the formal and informal markets in Latin American countries, and they certainly do in Bogota and Quito. This section examines some of the policies and programs developed within the formal sector, specifically those facilitating low-income homeownership in condominium.

The foundation on which housing policy is developed, either in the formal or informal sectors, is institutional: the constitutional housing rights and the human rights declaration regarding living standards, which includes the right to adequate housing (art. 25, Human Rights Declaration). This section is subdivided into two parts. The first reviews the constitutional housing rights of both Colombia and Ecuador. The second subsection offers a historical overview of the policies that facilitated low-income homeownership. The goal is to revisit the institutions and governance of policy and programs encouraging low-income homeownership to see how these have changed through the years, considering the role of government and the participation of the private sector.

§ 4.2.1 Constitutional housing rights

The existence of the right to housing within the national constitutions of Colombia (1991) and Ecuador (2008) has its origins in the Human Rights Declaration of 1948. Both countries have signed the International Covenant on Economic, Social and Cultural Rights, which is the international treaty adopted by the United Nations General Assembly in 1966. The Colombian State signed and ratified the treaty under law 74 of 1968 (Florian, 2012). Ecuador signed and ratified the treaty in January of 1969 (Garcia, 2014).

The right to housing in the Human Rights Declaration is mentioned in art. 25, which stipulates that everyone has “the right to a standard of living adequate for the health and well-being of himself and of his family, including food, clothing, housing and medical care and necessary social services ...”. This article names housing among the central and basic conditions that humans need to live, along with food, clothing, and health. Later, the United Nations’ definition of adequate housing was clarified, focusing on seven factors that together comprise the standard of living in adequate housing. An adequate home has the following elements: (1) security of tenure; (2) availability of services, materials, and infrastructure; (3) affordability; (4) habitability; (5) accessibility; (6) location; and (7) cultural adequacy (UN-HABITAT, 2014). Both renting and owner-occupation should occur in adequate homes. If a country wants to fully satisfy the right to housing for its population, it has to start out on a complex process and realize that a long road lies ahead. That ambition can be achieved gradually, considering that the process involves adopting a series of laws and programs regarding different aspects of housing (Florian, 2012). To ensure this right, governments have recourse to various instruments, such as planning and land use laws, property and rental laws, and even construction regulation, to mention just a few.

In view of what the housing right might involve, both Colombia and Ecuador have included the right to housing in their constitutions. Colombia's housing right is enshrined in the Constitution of 1991, Article 51:

Article 51. Every Colombian has the right to a decent housing. The State will arrange the necessary conditions to effectuate this right effective and will promote social interest housing plans, adequate long-term financing and associative forms to execute these housing programs."

(original language:)

Artículo 51. Todos los colombianos tienen derecho a una vivienda digna. El Estado fijará las condiciones necesarias para hacer efectivo este derecho y promoverá planes de vivienda de interés social, sistemas adecuados de financiación a largo plazo y formas asociativas de ejecución de estos programas de vivienda.

As this right is enshrined in the constitution, it is understandable that the national government would promote public policy under three main housing strategies: a) mass housing provision; b) adequate long-term financing systems; and c) different forms of association to manage the development and financing programs (Florian, 2012:109). Florian also pointed out that since the adoption of the right to decent housing was included in the Constitution of 1991, no efforts have been made to define what decent housing means for public policy in Colombia. Florian suggested following the guidance of the International Covenant on Economic, Social, and Cultural Rights regarding what it means to ensure adequate living standards. The seven elements mentioned above serve in the end as parameters to measure the adequacy of someone's home (Florian, 2012, p.110).

It is helpful to use the seven parameters as indicators of whether housing is adequate, and in that vein Florian identified a group of collective conditions external to the housing unit: infrastructure, public services, location, transportation connectivity, education, and health-related services (Florian, 2012). Another group of parameters refers to those qualities of the house existing inside the space occupied by each family. Government involvement as well as housing policies and programs generally concern the first group of rights, since they are considered a priority; collective conditions are not only more expensive but also require the coordination of city planning regulations and management.

As will be shown in the next sections, housing subsidy policy in Colombia is focused on two aspects of art. 51. First, it promotes the provision of affordable dwellings; second, it facilitates a financial market that would create opportunities to buy mass-produced dwellings. Both the provision and the financing mechanisms steer the institutions and actors towards housing units that will be sold in the market. Although the Constitution does not explicitly grant people the right to a house in ownership, both the policy and programs are geared towards this end. In a sense, talking about housing rights is like talking about merchandise that can either be bought or not. According to the United Nations Declaration, a housing right is more complex than an individual right to a private good.

In comparison, the Ecuadorian Constitution (2008) defines the housing right more extensively. It includes a right to 'habitat and housing' in articles 30 and 31. Then articles 375 to 376 explain the responsibilities and competencies that local governments must have to ensure the right to habitat and housing.

Article 30. Everyone, independently of their economic or social situation, has a right to a safe and healthy habitat and adequate and decent housing.

Article 31. Everyone has the right to enjoy the city and its public spaces under the principles of sustainability, social justice, respect for different cultures, and a balance between the urban and the rural. The right to the city is based on the democratic management of it, on the social and environmental function of property and of the city, in full exercise of citizenship.

(original language:)

Artículo 30. Las personas tienen derecho a un hábitat seguro y saludable, y a una vivienda adecuada y digna, con independencia de su situación social y económica.

Artículo 31. Las personas tienen derecho al disfrute pleno de la ciudad y de sus espacios públicos, bajo los principios de sustentabilidad, justicia social, respeto a las diferentes culturas urbanas y equilibrio entre lo urbano y lo rural. El ejercicio del derecho a la ciudad se basa en la gestión democrática de ésta, en la función social y ambiental de la propiedad y de la ciudad, y en el ejercicio pleno de la ciudadanía.

Unlike the wording of the constitutional housing right in Colombia, the Ecuadorian Constitution first presents the main principles and then rights are elaborated. Later, art. 375 to 376 within the Good Living¹⁷ regime of the Constitution expand on the ways in which the national state is bound to guarantee people's right to habitat and housing. The first obligation is to generate the necessary information for the design of strategies and programs. The second is to maintain a modern and geo-referenced cadaster of habitat and housing. Third, the state should implement and evaluate policy, plans, and habitat programs for universal access to housing. Fourth, the state will improve precarious housing conditions by creating shelters and public spaces and by promoting renting. Fifth, the government will develop plans for social interest housing and related financing programs through public banks and other financial institutions, mainly serving low-income people and female heads of household. Sixth, the state will guarantee the provision of public services to schools and public hospitals. Seventh, it will ensure that everyone has the right to rental contracts at a fair price and without abuses. Lastly, the eighth obligation is to guarantee public access to seashores and river basins; furthermore, the state will be responsible for the planning, regulation, control, financing, and development of policies for habitat and housing. To effectuate this right, art. 376 allows municipalities to expropriate, reserve, and control land for the future.

In summary, the Constitution of Ecuador asserts the right to housing in conjunction with the rights to habitat, which includes those collective rights that Florian explained with respect to the Colombian law. However, a special feature of the Ecuador's constitutional housing right is the clear separation of rights from the rules on how to put these rights into practice. In this section, it has been shown that the state plays a particularly prominent role in the coordination of the efforts of municipalities. Another aspect of how these rights are implemented is revealed by looking into the types of tenure, both renting and owning.

Housing rights can be understood as complex, not limited to the right to homeownership or a dwelling in private property (Florian, 2003:6). This conceptualization of the right to housing has steered all of society's and government's efforts to address housing problems towards producing new homeowners (Florian, 2003:7). While there are many ways to solve housing problems, homeownership is often treated as a self-evident solution in policies framed under the constitutional housing rights as it will be seen in the policy sections of this chapter.

§ 4.2.2 The changing role of government in housing policy

Within the formal provision of housing, national governments have intervened in different ways over the decades. This section gives an overview of the programs that illustrate the changing role of government in order to provide some context for understanding current subsidy policy. As this section demonstrates, even though the strategies have changed, the focus on policies for owner-occupation remains central. This path dependence in homeownership is evident in the housing data presented in the following sections.

Colombia created the Institute of Territorial Credit (ICT) in 1939. Decades later, Ecuador created the Ecuadorian Housing Bank (BEV) together with National Housing Board (JNV) in the 1960s. National governments in Colombia and Ecuador created these housing institutions with the role of affordable housing providers for low- and middle-income families during periods of rapid urbanization and population growth. These institutions, that were both financiers and builders, also built public services and streets of housing developments and financed the mortgages for families buying social interest housing (Held, 2000). Many of the housing complexes dating from this phase of housing policy were built in mid-rise apartments in the style of European modern architecture (Ballen, 2009).

By the 1990s, the production of housing by the national governments was not sufficient to meet the housing need in the capital cities of Bogota and Quito (Lizarralde, 2015; Molsalve, 2003). The evidence of a shortfall is clear from the rapid expansion during this period of informal settlements in both cities (Gilbert & Ward, 1982). Moreover, it became obvious that public housing was not built for the poorest; the programs excluded people with informal jobs and those who cannot apply for a mortgage (Maldonado, 2005). Therefore, by the beginning of the 1980s, housing policy implementation took a different approach, turning away from the state-led mass-provision of finished dwellings for owner-occupation.

Research into informal activity helped to clarify that squatter settlements were not exactly a housing problem; rather, these were better seen as a housing solution provided by and for the urban poor (Bromley, 2003; Mangin, 1967; Rojas, 2010). Learning from informal and, more specifically, incremental ways to build a house, international agencies began to fund different housing programs with an emphasis on serviced land. The main thrust of this policy phase was to provide small plots of land with public services and finished streets. On these lots, families were able to build their houses with professional assistance, through community work, or by themselves. In practice these sites-and-services policies did not last long, since cheap land and urban

expansion became of overriding importance (Zanetta, 2001). Since sites-and-services housing policy did not produce the expected outcomes, different Latin American countries embarked on developing a new approach.

At the end of the 1980s in Colombia and the beginning of the 1990s in Ecuador, public policy implementation and public services provision underwent change. This is the phase during which privatization of public services took place. In the process, development was reoriented towards a neoliberal agenda in which the role of nation states in public policy started to shrink (Rolnik, 2013). Decentralization of policy implementation along with the modernization processes taking hold during the 1990s changed the way government implemented housing programs. Its role shifted away from direct involvement in provision towards subsidization alone (Klaufus, 2010). For example, the role and functions of the ICT in Colombia were absorbed into a new institution, the National Institute for Social Interest Housing and Urban Reform (called INURBE). In 1991 the law created both INURBE and the system of incentives enabling the affordable housing market. Later, INURBE was closed but the system of family subsidies remained in Colombia.

Something similar occurred in Ecuador in the 1990s. The Ministry of Urban Development and Housing was created to manage the first international loan given by the Inter-American Development Bank with the intention to launch the subsidy program or housing certificate (*bono de vivienda*) for low-income homeownership (Klaufus, 2010). When the subsidy policy was launched, the Ecuadorian Housing Bank (BEV) stopped building housing units (Personal interview with former President of Ecuador, Sixto Duran Ballen, 2011).

The main idea behind the incentive-based housing program is to create a system to provide affordable housing for low-income families. This system is built upon a network of both public and private actors, who create a market of low-cost housing for low-income owner-occupation. To steer the actors in this system, the government planned a subsidy policy, actually an incentive or down-payment assistance, to help families become eligible for loans in the financial market (Ferguson et al., 1996). This incentive attracts housing developers into the affordable housing market because the subsidy secures an effective demand or prospective buyers (Ferguson & Navarrete, 2003).

The structure of this last phase of housing policy is similar in many Latin American countries (Gilbert, 2004, 2012b; Rojas, 2001). The next section examines the subsidy strategy in more detail.

§ 4.2.3 The Latin American subsidy policy for low-income homeownership

This section describes the basic structure of the program and its main objectives. The specific details will be explained in the section devoted to each country. In principle, households have to meet requirements under the following headings: a) subsidy, b) savings, and c) mortgage.

Regarding the requirements under heading a), to be eligible for a subsidy a household first needs to prove vulnerable conditions or poverty levels; second, the household cannot have any other property in ownership. Income eligibility thresholds are set according to each country's economic conditions and monthly basic salary standards. The subsidy, which is given directly to the builder of the project, is granted to households that have already chosen a project in which they are interested.

To complete the application process, households need to have some savings in a bank account. In Colombia this particular part is arranged jointly with the private organizations that manage social security funds. The amount of savings, together with the subsidy, would make a household eligible for a small mortgage with any private bank that is part of the incentive system for housing.

Table 4.1 below summarizes the different actors involved in the system and their roles. In subsequent sections, this table will be adapted to the specific situation of each country and city. In the end, the role of the municipalities is critical; it is the land policy that makes it possible to provide more affordable land for builders of low-cost housing.

ORGANIZATION	INSTITUTIONS: REGULATION
Housing Ministry	Subsidy allocation and affordable housing provision
Municipality	Land policy instruments for affordable housing provision
Lending sector	Affordable financing for low-income families Builder's financing mechanisms

TABLE 4.1 System of housing incentives for low-income homeownership

§ 4.3 Housing market in Bogota, Colombia

Bogota, known as the Capital District of Colombia, is the biggest and most populous city in the country with 7,785,965 inhabitants (Dane, 2014). In 1964 the population was 1,697,311 and it grew rapidly to 3,982,941 in 1985. The annual growth rate in the 1960s was 7.83% but has since slowed down to 1.85%, calculated in 2010.

The territorial and political organization of Colombia, based on the 1991 Constitution, positions the Capital District at a similar administrative level as one of the departments of Colombia, which are like provinces in other countries like in Ecuador. As a Capital District, it has a two-tiered system of government: first the city level with a city council; second the 20 'localities', each with an appointed mayor and an elected council from the corresponding territory (Ardilla-Gomez, 1997). Since 1983, the city charges public service fees according to division of the territory into six socioeconomic levels. The city is stratified by the quality of the housing stock as it is organized by homogeneous characteristics, following physical and habitat features (Alzate, 2006). The stratification goes from stratum 1, which means poor housing quality and socioeconomic levels, to stratum six in wealthier zones (Alzate, 2006). During phases of exploratory research, it was confirmed that stratum 1 consists mostly of barrios that grew more informally, and social interest housing is generally built in locations qualified as strata 2 and 3.

The Capital District has a total of 2,421,945 households (DANE_ECV, 2014). Household composition breaks down as follows: 12% one-person households, 20% two-person, 26% three-person, 26% four-person, and 16% households with more than five people. Ideally the housing stock of the city should adjust itself to that composition to avoid overcrowding. In general numbers, comparing the total number of households with the total number of housing units as of 2014 (2,391,709) yields a quantitative housing deficit of 30,236 units.

Data from 2014 shows that 9.1% (220,801) of the households have some housing deficit, either quantitative or qualitative. Out of all households coping with a housing deficit, 60.4% have some sort of qualitative deficit; for instance, they may need improvements in the house structure, within the infrastructure, or public services. Households with a quantitative deficit are those that need a separate dwelling; this group represents 39.6% of those identified with a deficit (Habitat Bogota, 2014).

§ 4.3.1 Owner- and renter-occupied stock

As the population grows, owner-occupation is reduced while renting becomes more common. Figure 4.1 shows that in the 1960s more than 60% of households were owner-occupiers and about 25% were renters. Even though homeownership is the focus of the housing policies implemented in both formal and informal housing markets, renting is clearly on the rise in Bogota. Currently, the number of households renting matches the number occupying their dwellings as owners. Of the 1,088,102 households that owned the dwelling they occupy, 82% owned it outright while 18% of them were still paying a mortgage (DANE, ECV 2014).

The forms of occupancy classified as 'other' refer to dwellings that are occupied as part of a service performed, such as domestic work or in exchange for some kind of labor. The category also includes occupancy as usufruct, such as an apartment given to one member of family but not in exchange for rent. These particular forms of occupancy decreased considerably from the 1960s until 2005. However, statistics show an increase to 14% in 2007 and then a reduction to less than 10% in 2014.

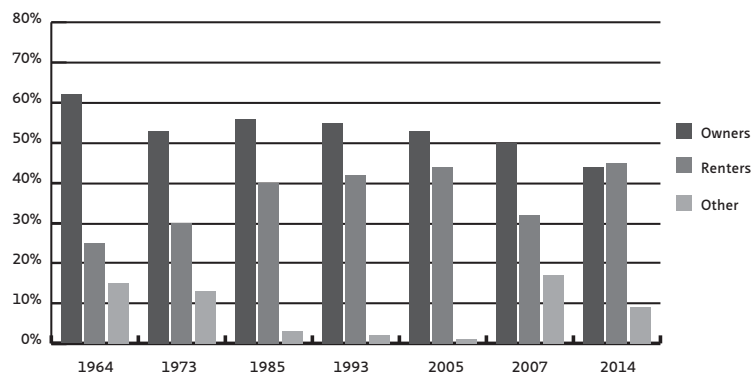


FIGURE 4.1 Bogota: percentage of occupied housing units by tenure 1964-2014 (sources: Data from Census by DANE (*Censo de poblacion y vivienda*); data for 2007 estimated by CENAC; data for 2014 by ECV Survey (Colombia)).

Other = other forms of tenure are 'service' or 'usufructo'.
Elaborated by the author.

§ 4.3.2 Housing by type

Figure 4.2 arranges the total number of occupied dwellings by typology. Units are classified as single-family (attached or detached), apartments or flats, single rooms, or 'other', such as convents or jails. Looking at the statistics since the 1970s, it appears that the trend of densification in Bogota was followed by changes in the housing stock. Bogota has changed; from a city of low-density, single-family houses in the 1970s it has turned into a city of high-density apartment dwellings, markedly from 2005 onward. The lines indicating the different types in the graph below intersect in about the year 2000, and from then provision changes the direction towards more production of apartments and less single family dwellings. Currently, the housing stock consists of more than 50% apartments and 40% single-family dwellings, with the rest being other types of housing.

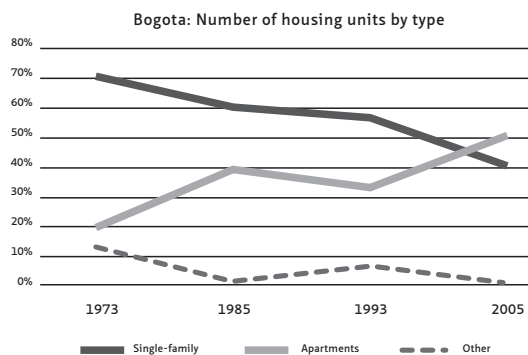


FIGURE 4.2 Bogota: percentage of housing units by type 1973-2005 (source: Census, DANE)

Other = cuartos, inquilinato, desechos, rancho, carpa, en construcción, colectivas.

Elaborated by the author. .

§ 4.3.3 Condominium housing stock in Bogota

As explained in chapter 3, one limitation of a census and surveys of quality of life is that these register the type of tenure, not its form. The problem is that a typology does not provide information about the form of tenure of the unit. Both renting and owning, and both single-family houses and apartments, can fall under the condominium

regime. Therefore, cadaster data was gathered and analyzed to compile the statistics represented in Figure 4.3. That graph visualizes how relevant the understanding of condominium institutions and governance problems is to managing the housing stock of a city. The share of housing units in condominium is as high as 60% of the housing stock, which means that there are about 1,358,025 units in condominium in Bogota (Cadastre, 2016). It was not possible to determine the number of complexes in condominium on the basis of the current data available from the census and housing surveys. Looking at Figure 4.4, however, one observes a consistent growth of housing in condominium tenure through the decades since the adoption of the horizontal property law in Colombia in 1948.

Bogota is stratified by income and the quality of the housing stock, which allows the cadaster to provide information about condominium housing by economic strata. The most updated information from 2015 provided by the Cadaster of Bogota for this research shows that 0.08% of the units in stratum 1 are in condominium (1138 units), while 16.80% are in stratum 2 (228,241 units). The biggest share of housing in condominium is in stratum 3 with 31.95% (434,026 units) and stratum 4 with 30.20% (410,313 units). Housing in horizontal property of strata 5 and 6 together represents 21% of the housing stock. This information confirms that condominium tenure in Bogota is not particularly intended for higher-income occupants. In summary, the city has a total of 663,405 units in condominium from strata 1 to 3, corresponding to low- and middle-income groups.

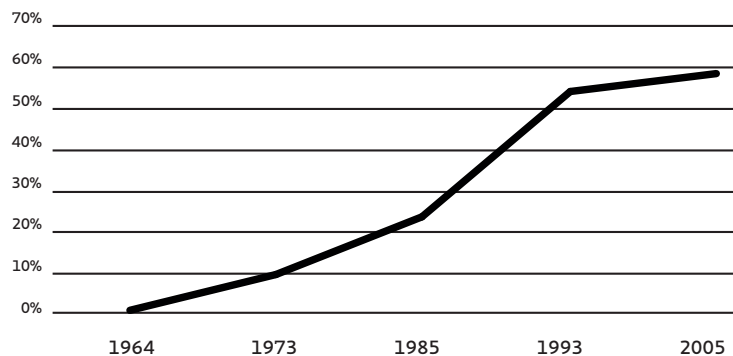


FIGURE 4.3 Bogota's housing stock: percentage of housing units under condominium regime 1964-2005 (sources: Census Data (Dane) and Cadastre Bogota, July 2011)

Horizontal Property or condominium property. Elaborated by the author.

§ 4.3.4 Subsidy policy in Bogota, Colombia

The national subsidy policy created in 1991 in Colombia provides one-time assistance for households to purchase a house or an apartment that has been identified as social interest housing (VIS). Even though the subsidy system has undergone some minor changes through the decades, the system and the actors involved remain similar. There are four organizations through which households apply for and receive subsidies in Colombia. All are related to the welfare institutions that manage savings or pension funds, and also some of the subsidies are channeled through the public agrarian bank when the recipient is a family living in a rural area. These four organizations are: (1) the National Savings Fund (FNA); (2) the Family Welfare Agency, which is made up of private agencies (Cajas de Compensación Familia, CCF) that manage pension funds of workers in the formal economy; (3) the Military Housing Promotion Agency; and (4) the Public Agricultural Bank (Arbelaez, Camacho & Fajardo, 2011).

INCOME RANGE (SMLVM*)	INCOME CEILING SMLVM -2016 = 644,360 COLOMBIAN PESOS	SUBSIDISED SMLVM UNITS	IN COLOMBIAN PESOS	IN US DOLLARS (2016)
>0 - 1.00	644 350	22	14 175 700	4 976
>1.00 - 1.50	966 525	21.5	13 853 525	4 863
>1.50 - 2.00	1 288 700	21	13 531 350	4 750
>2.00 - 2.25	1 449 788	19	12 242 650	4 297
>2.25 - 2.50	1 610 875	17	10 953 950	3 845
>2.50 - 2.75	1 771 963	15	9 665 250	3 393
>2.75 - 3.00	1 933 050	13	8 376 550	2 940
>3.00 - 3.50	2 255 225	9	5 799 150	2 036
>3.50 - 4.00	2 577 400	4	2 577 400	905

TABLE 4.2 Subsidy levels by income range in Colombia (elaborated by the author, based on information available at the Welfare Family Agencies, website.)

SMLVM = four basic monthly salaries COP 644,360 (Colombian pesos) in 2015

From 1991 until 2009, the FNA and CCF allocated 72% of the subsidies. The rest were allocated by the Military Housing Promotion Agency and the Public Agricultural Bank (Arbelaez et al., 2011). The Family Welfare Agency, comprised of numerous *Cajas de Compensación Familiar* (CCF), was created in 1954. Today Colombia has a total of 53 CCF agencies around the country, and workers are free to choose the one through which they want to be registered. By definition they are “juridical persons of private rights, without profit purpose, organized as corporations, that conform to welfare functions,

which are controlled by and under supervision of the State” (Art. 39 Law 21, 1982 in Colombia, 2004: 2). Law 21 of 1982 requires every employer in Colombia to give four percent of the total payroll to the CCFs. These funds are distributed among different channels of welfare assistance, such as housing subsidies, health, education, and unemployment.

Only families that earn less than four basic monthly salaries (SMLMV) are eligible for the housing subsidy (see Table 4.2). The subsidy can be granted to (1) purchase a new home, (2) build on a plot of land, or (3) refurbish a dwelling. The amount of subsidy depends on the income of the family that applies for it. Moreover, the award is progressive, which means that lower-income families receive higher amounts of subsidy than families earning almost four SMLMV. The following table specifies the relationship between income and subsidy and the total amount a family can receive.

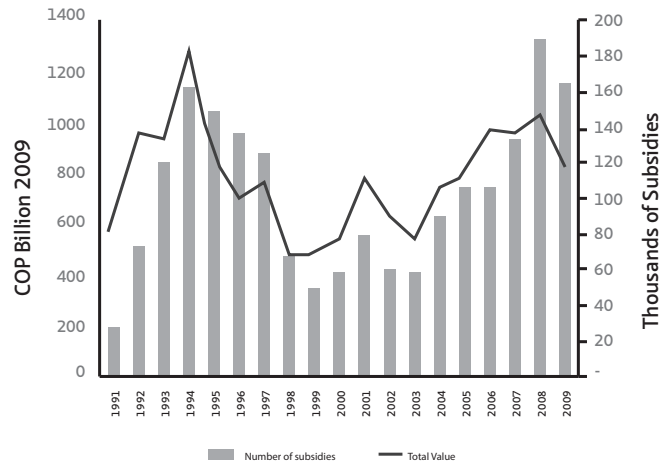


FIGURE 4.4 Allocated subsidies in Colombia 1991-2009 (source: Ministry of Environment, Housing and Regional Development (in: Arbelaez et al., 2011))

Figure 4.4 shows how the total amount dedicated to the subsidy has changed over the years. In 1991, the government invested over 500 million in Colombia pesos but was only able to allocate slightly more than twenty thousand subsidies. To ensure that there are houses on the market for people to buy, housing provision needs to go hand in hand with the subsidy allocation system. By 2009, the subsidy allocation improved, dedicating more than 800 million Colombian pesos and allocating 160 thousand subsidies. City-level land policy and regulation are also related to the increase in housing provision. In summary, the policy regulates the system and how it works for

households. The total amount of funding allocated for the subsidy is based on housing deficit calculations, and the funds are distributed around the country. However, since Bogota is the biggest city in Colombia and has the highest housing deficit indicators, it is generally the territory that receives and allocates most of the subsidies (CAMACOL, 2012).

§ 4.4 Housing market in Quito, Ecuador

Quito, the capital of Ecuador, has 2,239,191 inhabitants (Census, 2010). In 1993, during the decentralization and modernization process, Quito became a metropolitan district in order to carry out elements of public policy and policy implementation. One of its new competencies was the promotion of housing policies and programs. As a metropolitan district, Quito has a city council, directed by an elected mayor. The territory is divided into eight administrative zones, each managed by a person appointed by the mayor and the city council.

The population of the city is divided into a total of 640,753 households with an average size of three to four persons (INEC, 2010). To avoid overcrowding, the housing stock would ideally be adjusted to the current composition of households. Comparing the number of households with the total stock of 764,167 units, it appears that the city had no quantitative deficit in 2010. However, of that total, 634,611 housing units are actually occupied; 47,053 households are absent and 59,944 units are unoccupied. Additionally, 22,111 housing units were under construction in 2010.

Housing quality is measured in the census survey by observing the conditions of building materials of roofs, floors, and walls. The survey then includes qualitative measures to indicate whether the materials are in good, regular, or bad condition. In addition to these physical parts of the dwelling, another indicator of quality is the presence of both a tap for drinking water and a toilet inside the dwelling. In terms of these indicators, 71% of dwellings in the urban part of Quito have a roof of good quality, 25% have one of regular quality, and 4% have a bad roof. The same proportions apply to the quality of walls and floors. To summarize, about 25% of the housing stock has qualitative deficits that can be repaired or maintained, and about 4% of the housing stock needs to be replaced.

Out of a total of 466,960 housing units in urban Quito, leaving those in the rural parts of the metropolitan area out, about 20,000 units need repair on their roofs, walls,

and floors. Again, this information pertains to the individual unit, but for an analysis of condominium it is also necessary to know the state of the common property parts, which is generally not assessed in current housing surveys.

§ 4.4.1 Renters and owner-occupied stock

Tenure data on the period 1961 to 2010 from Quito demonstrates that while rental occupancy has decreased, the number of homeowner-occupied units has increased (see Figure 4.5). In 1961, 35% of all households owned the units they occupied, while 50% of the population were renters. The 1960s marked the starting point of the housing policy of mass provision of housing for homeowners. The city was growing and people were moving into the capital. During this decade, the growth of homeownership was constant, reaching 50% by 2010.

The household-level information reveals that, out of the 468,702 households in urban Quito, 148,089 own their dwelling outright while 35,123 are still paying on the mortgage. Another 38,758 own their dwelling because it was inherited or a gift. There are 202,417 households that rent, 3,521 that live in the place they occupy in exchange for service, and 1,248 that rent under the antichresis model, a form of lease (INEC, 2016).

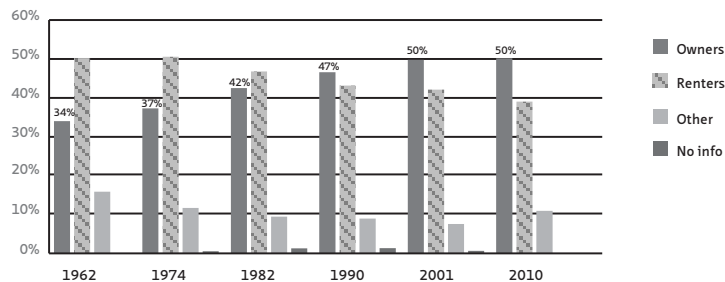


FIGURE 4.5 Quito: percentage of occupied housing units by tenure 1962-2010 (sources: INEC varios years)
Other = other forms of tenure are 'service' or 'usufructo'.
Elaborated by the author.

In Figure 4.5, the forms of occupancy classified as 'other' refer to dwellings that are occupied as part of a service performed, such as domestic work or in exchange for some kind of labor. That category also includes occupancy as usufruct, such as an apartment

given to one member of the family but not in exchange for rent. The incidence of such 'other' forms of occupancy has remained relatively constant over the past the decades, affecting around 10% of the population.

§ 4.4.2 Housing by type in Quito

Figure 4.6 shows the total number of occupied dwellings by typology. Units can be single-family (attached or detached), apartments or flats, single rooms, or 'other', such as convents or jails. An overview of the statistics since the 1960s shows a sharp drop in Quito's single-family housing market in the 1970s, when oil production started in Ecuador and boosted the economy. During the 1970s, cities grew rapidly as centers of new employment. Urban growth was particularly strong in Quito, where apartment living was more culturally acceptable than in other cities of Ecuador; both private and public developers built mid-rise apartments in different parts of the city. Figure 4.6 shows the trend in apartment development. Starting from zero in the 1960s, when the horizontal property law was first promulgated, it rose to 20% in only a decade in the 1970s, and then continued to grow, supplying more than 30% of the market by 2010.

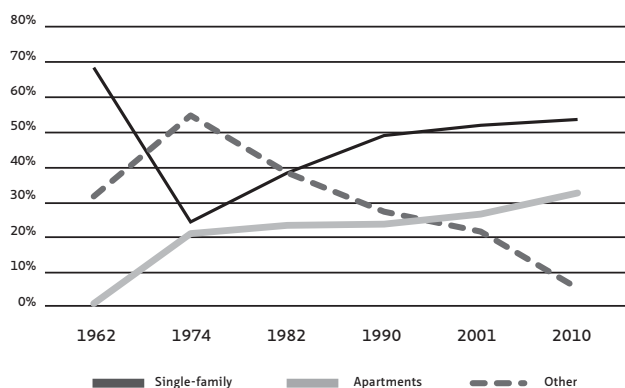


FIGURE 4.6 Quito: percentage of housing units by type (1962-2010)(source: Data from Census INEC (*Censo de poblacion y vivienda*). Elaborated by the author.

After the drop in single-family development in the 1970s, the trend of single-family housing was revived. Quito expanded its territory in all directions, even into the valleys of Los Chillos and Tumbaco, which are 400 meters below the main plateau of the city. Single-family houses are the preferred typology in the housing market, and housing developers have responded to this demand. Today more than 50% of the housing market consists of single-family dwellings, either attached or detached.

As explained earlier, condominium housing is not related to housing typology. Both apartments and single-family housing can be developed under the condominium form of tenure. However, neither the census nor the housing data provide information at this level. Therefore data had to be obtained from the cadaster department of the municipality in order to investigate the condominium market in Quito.

§ 4.4.3 Condominium housing stock in Quito

The data presented in this section was obtained from the cadaster in 2011. As explained in chapter 3, there are some limitations to the census data, so other databases had to be accessed. Considering that the housing market in a Latin American city operates both formally and informally, the cadaster data relates to the formal market. As shown in Figure 4.7, out of all registered units with residential use in the cadaster, 45% are under the condominium regime. Comparing this number to the total number of housing units in the city, 21% of the housing stock in Quito is under the condominium regime.

With this data it is possible to demonstrate that the condominium regime is a housing sector that goes unreported in the census and housing data. This omission is harmful when measuring housing quality regarding the elements of the property. Census and housing data only refers to individual units. However, when housing is collective it is also necessary to measure the common elements, such as the common patio, internal walkways, pipes, and other structural elements of the building or housing complex.

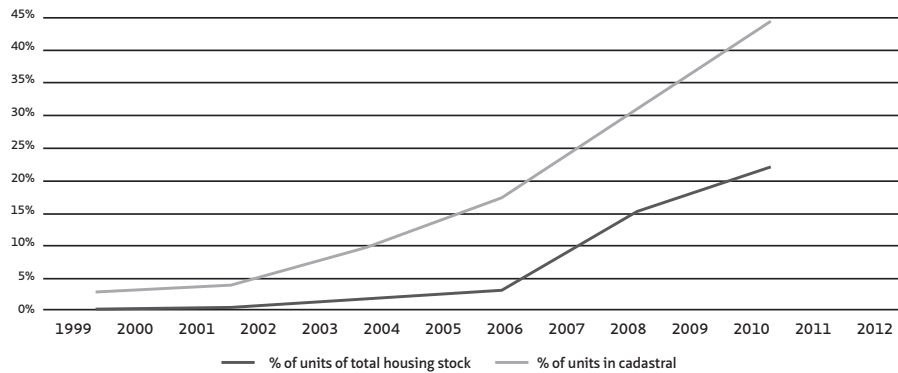


FIGURE 4.7 Quito's housing stock: percentage of housing units in condominium regime 1962-2010

Sources: Census Data (INEC) and Cadastre Information, Informatics' Department June, 2011.

Note: Total number of housing units from Census data includes data from all the metropolitan areas (DMQ). Cadastre information includes as housing units: 'Casas/lote' and 'Departamentos'. Years correspond to cadastral date. 5.6% of missing year values. Computed on SPSS 14.

Elaborated by the author.

§ 4.4.4 Subsidy policy in Quito, Ecuador

The national subsidy policy that was created in 1998 is a one-time assistance for households to purchase a house or an apartment identified as social interest housing (VIS). The Ministry of Urban Development and Housing (MIDUVI), which was established in 1992, incorporated the voucher system into the subsidy housing policy not only to help people buy new affordable dwellings but also to offer a subsidy for housing improvement or refurbishment (Acosta, 2009). The total amount dedicated to the national subsidy policy varies according to the political administration in charge. For example, in 1998 a total of 23,833 subsidies were given to families for new dwellings and 24,054 for housing improvement. During the next presidency starting in 2003, only 10,623 subsidies were granted for new housing while 15,702 were granted for housing improvement (Acosta, 2009:100). This illustrates that changes in housing subsidy policy are recurrent, so shifts are inherent in the not-so-stable system of subsidy allocation.

A considerable amount of change has occurred since 2007 under the new socialist government and in a more politically stable Ecuador. After 2001, the currency was dollarized; Ecuador started using the American dollar as its official currency. By stabilizing inflation, the dollarization process has increased the amounts budgeted

for housing policy as well as other welfare policies established in the new Constitution of 2008. In addition to the political context, oil prices rose internationally to over 100 dollars per barrel. The effect on the local economy made a high amount of liquidity available to a government for social policies. However, after almost five years of bonanza, oil prices dropped drastically in 2014, starting an economic crisis. Currently, many of the social policies implemented in Ecuador under this government have therefore been left without liquidity.

The economic situation has affected not only housing programs but other sectors of the economy as well; nonetheless, the changes in housing policy are important for the economy at large. The subsidy ceilings were raised in order to keep up with the new construction prices and housing needs. After 2007, the subsidy for new dwellings was increased from 4,000 dollars to almost 6,000 dollars for urban dwellings and similar increases were made in subsidies for housing built for households living in rural areas. Additionally, families could apply for generous relocation subsidies if they lived in areas susceptible to natural hazards, and a subsidy was offered for people with disabilities. Finally, a new subsidy was put in place to facilitate the land titling programs for families living in squatter settlements (Acosta, 2009).

In the course of a research project like this one, the data keeps changing due to different political decisions; the amounts given in Table 4.3 changed at least twice in the last four years. The data presented there refers to the policy of 2013, when the basic income salary (SBU) was 318 dollars. In 2016 the SBU was 366 dollars. The subsidy for apartments and for single-family housing is intended for households that earn up to 2.9 times the SBU, which put the income ceiling at about 922 dollars in 2013 and at 1061.4 dollars in 2016.

TYPE OF SUBSIDY	ELEGIBLE FAMILY INCOME	VALUE OF HOUSING UNIT (IN US DOLLARS)	OBLIGATORY SAVING (IN US DOLLARS)	SUBSIDY LEVEL (IN US DOLLARS)
Subsidy for new housing (apartments)	Unitl 2.9 SBU	15,000	434	6000
		20,000	723	5000
		25,000	1978	3500
		30,000	2529	2500
Subsidy to buy single-family house	Unitl 2.9 SBU	15,000	706	5000
		20,000	1129	4000
		25,000	2472	3000
		30,000	3146	2000

TABLE 4.3 Subsidy policy for new dwellings in Ecuador (source: <http://www.habitatyvivienda.gob.ec/>)

*SBU - Salario Básico Unificado. In 2015 it was \$354

In Ecuador, the subsidy policy is expressed in the formula SAVINGS + SUBSIDY + CREDIT, which in Spanish is *Ahorro, Bono y Credito*, abbreviated as ABC. Households have access to the credit through banks or financial institutions that are registered with the National Corporation for Popular and Solidarity Finances. This corporation acts as a mortgage security guarantee system along with the private institutions that are registered. The savings account the households need to open is also connected to the National Corporation for Popular and Solidarity Finances.

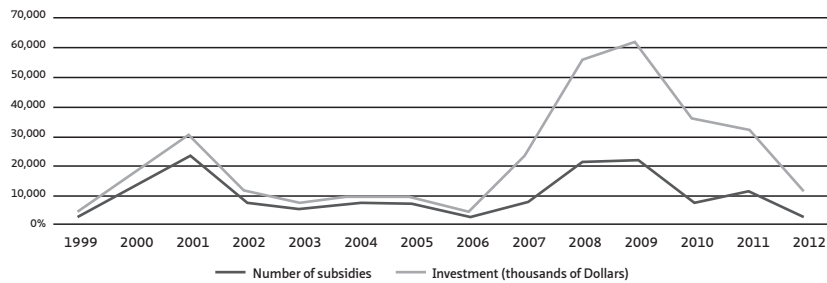


FIGURE 4.8 Subsidy allocation for new dwellings from its start in 1999 until 2012 in Ecuador (source: Housing Ministry (MIDUVI, 2012), provided for this research. Elaborated by the author)

Figure 4.8 shows both the total amount of money invested in new urban dwellings and the total amount of subsidy that was actually given to families at the national level. Using information from 2012, as provided by the Ministry of Urban Development and Housing for this research project, it appears that the investment was high after 2006 but the subsidy allocation was low. There were some problems in housing provision by the private sector, as also happened when the government was building by itself.

§ 4.5 Comparative perspective

Both countries have had housing policy and programs managing the provision of housing for owner-occupation since the mid-twentieth century, and in Colombia these existed even earlier than in Ecuador. The constitutions of both countries recognize the right to housing, and therefore policies in both countries are aimed at reducing housing deficits through the provision of new dwellings. It is interesting to trace the path dependence of policy promoting owner-occupation, as it elucidates the way

both markets and policy adapt to the homeownership goal. Even though the role of government in housing provision has changed, the focus of policy on homeownership remains the same.

It was decided to base this analysis on the kind of information that is available in both Bogota and Quito so that the results would be comparable. The purpose of the market analysis was not to examine affordability or quantitative deficit but rather to characterize the condominium housing market in these two capital cities. Since affordable condominiums, both as single-family housing and as apartments, are subsidized by the government, the analysis could be based on the assumption that all the units developed in both Bogota and Quito are units that fall under the condominium regime.

The limitations of the data hamper a full understanding of the conditions of condominium housing, as has been demonstrated in this chapter. However, some very important historical data has been presented here, and it is interesting to compare it. In Bogota, renting is the main housing tenure, although about half of the households own the place they occupy. In terms of typology, the construction of single-family housing development is surpassed by the supply of apartment housing. Likewise, the high proportion of apartment housing in the stock is correlated with the high percentage of condominiums in the city. In Quito, even though the renter-occupied housing stock is large, owner-occupation is strong. The stock of single-family housing is still a key sector in the housing market. However, even though single-family housing is primarily built as individual units, these are developed in condominium tenure in small housing complexes.

The subsidy policy and the number of dwellings built under this program give some indication of how many of the units on the housing market are basically promoted with subsidies for homeownership. The statistics on subsidy for both countries show the total number of units as individual units, but they are not. A more accurate database of policy outcomes could provide the number of housing complexes or the number of condominiums developed in addition to the total number of individual units. As these affordable units will remain under condominium governance, these housing complexes are prone to deterioration if they fail to organize themselves.

The section above that introduced the policies mentioned the different actors that form critical parts of the system. In Bogota, the role of the Welfare Family Agencies is pivotal within the subsidy allocation system and currently even in housing provision. These private institutions with a public purpose have direct relationships with future homeowners; they know their housing demands and can therefore organize housing provision more efficiently than in Quito.

In Ecuador, the subsidy allocation system is managed by the Ministry of Urban Development and Housing in a decentralized institution working with provincial offices. That ministry registers and certifies developers as affordable housing providers. Only those that are registered are able to build and sell affordable housing because they can count on receiving the subsidies upfront, which gives developers an incentive to build for the future homeowners that are subsidy holders.

The above overview of the existing data (or the data that is lacking) provides a justification for the research approach and the comparative analysis that are presented in the next chapters. The discussion of the existing data also demonstrates that the condominium form of tenure is largely overlooked in current housing analysis and policy outcomes statistics.

5 The formal institution: The horizontal property law

§ 5.1 Introduction

The amount of literature on institutional analysis is vast. But what an institution means is not always clear, which has led to some problems in the social sciences. Misunderstanding can arise from the language used in the discourse on institutional analysis. In this regard, Ostrom explains that “rules and norms are at the heart of many core theoretical questions having to do with how individuals coordinate activities with one another” (Ostrom, 2005:179). Rules help to coordinate activities, as the law of horizontal property aims to do, in addition to constituting property rights in a bundle for both individual and collective owners. Although laws are produced and interpreted in the social arena (Keog & D’Arcy, 1999 cited in Oxley, 2004), this chapter treats the law on horizontal property as a formal body of regulations that creates a rule-structured boundary around the different actors. Seen thus, the law is the main formal institution that organizes authorized actions in the provision of housing in condominium (Ostrom et al., 2006).

Legal scholars have already explained how the condominium property system can operate using Ostrom’s design principles (Glasse & Berrisfor, 2015). Ostrom (1990) did not identify any specific rules or written laws underpinning successful management of a common property resource. However, she did find a set of design principles that are present in all of the cases that she studied. She compared these to cases that had failed, thereby confirming the validity and identifying the qualities of robust institutions in common property resource management (Ostrom, 2009b). These principles fall under the following headings: (1) clearly defined boundaries; (2) proportional equivalence between benefits and costs; (3) collective choice arrangements; (4) monitoring; (5) graduated sanctions; (6) conflict resolution mechanisms, (7) minimal recognition of rights to organize, and (8) nested enterprises (Ostrom, 1990:90). Many of these arrangements can be either laid down in law or agreed upon informally by the agents that manage the common resource.

Within the multilevel structure of the IAD framework (Ostrom et al., 2006), there are three levels of rules that a common property resource may have. These are the operational, collective-choice, and constitutional-choice rules.

What the role of the law of horizontal property entails for governance and management of condominiums is central to this thesis. In line with this interest, the following questions will be answered in this chapter:

- Which parties are regulated by the horizontal property law?
- How is the law structured?
- What are the similarities and differences between Colombia and Ecuador’s horizontal property laws?

Section 5.2 gives an overview of the literature on condominiums. Some of that research looks into the historical grounds of this form of ownership. And some contemporary research has been done from a socio-legal angle showing the conflicts regarding rules and actors. The socio-legal perspective taken in this chapter is introduced in this section, along with the levels of rules identified by Ostrom.

Section 5.3 responds to the first question by showing which parties are regulated by the law. This section identifies which agents of condominium institutions are involved in the rule-structured situation of low-income condominium housing development processes, emphasizing how the law regulates interactions among them (Ostrom, 2005).

Section 5.4 responds to the second question by explaining the structure of the horizontal property laws of Colombia and Ecuador. The socio-legal framework helps to deconstruct the structure of both laws, highlighting the different legal environments in which the laws operate. By understanding the structure of the laws, it is possible to assess which of Ostrom’s principles are embedded in the respective property laws.

Section 5.5 concludes the chapter with an account of what is regulated in the condominium regime. The emphasis lies on governance and management of the maintenance of the common property resource. This section takes a comparative perspective and draws out the differences between the laws, which will set the stage for comparisons in subsequent chapters of this thesis.

§ 5.2 Studies on condominium regulation

Condominium property law is known by different names, depending on the region where it is located. It is called strata title in countries with a common-law tradition such as Australia and Israel (Alterman, 2010). In countries with a civil law tradition, condominium law is called apartment law in the Netherlands (Weesep, van, 1984), while it is called condominium or horizontal property in Eastern Europe (Orban, 2006; Soaita, 2012) and Latin America. Condominium property is also found in Asia and Africa; depending on the country, there are mixtures of common-law and civil law provisions within the condominium rules (Chen, 2011; Hsieh, 2009; Merwe, van der, 2015; Park & Baek, 2012).

In China and Hong Kong, which have public ownership of land, multi-family regulations concern management strategies, not the common ownership of the land and the building (Yau & Ho, 2009; Yip, 2010). In the USA, individual states adopted enabling legislation, learning from practices in Latin America, more specifically from the law in Puerto Rico, after the Supreme Court allowed US financial institutions to issue mortgages on property in condominiums in the 1960s (Rohan, 1978; Weesep, van, 1987; Rosen & Walks, 2013).

The Napoleonic Code of 1804 is important in countries where civil law pertains, or where the French and Spanish legal systems have had a strong influence, notably in Latin America.

Article 664 of the Napoleonic Code is the direct reference for the separate ownership of floors and the regulation of maintenance and repairs of common property elements (Bennett, 2011; Merwe, van der, 2015):

Art. 664. When the different stories of a house belong to different proprietors, if the titles to the property do not regulate the mode of reparations and reconstructions, they must be made in manner following:

The main walls and the roof are at the charge of all the proprietors, each in proportion to the value of the story belonging to him.

The proprietor of each story makes the floor belonging thereto.

The proprietor of the first story erects the staircase which conducts to it; the proprietor of the second story carries the stairs from where the former ends to his apartments; and so of the rest.¹⁸

France, where urban density is high, particularly in Paris, became the model for the transfer of property rights of vertical space and airspace. In the 1860s, French notaries developed “improved techniques for conveyancing, and these were codified into law” (Glasse & Berrisfor, 2015:216). This is how the ‘condominium model’ started to spread around the world. Even though there are some differences among countries, the basic rule stipulates the individual ownership of the apartment space and the common ownership of the rest, including land (Lujanen, 2010).

The legal framework under which housing providers sell condominium housing has been studied by legal scholars in the United States since the first condominium act was passed in the 1960s. At first it was seen as something completely new but necessary to build the American metropolis, where apartment real estate and offices can be easily traded in the market (Cribbet, 1963). The transactional efficiency of units in condominiums was preferred to that of the cooperatives, as Hansmann (1991) noted when explaining the spread of condominium tenure in the United States. Mortgage financing in cooperatives is collective, whereas in condominiums financing applies to the individual unit (Hansmann, 1991). The condominium scheme was initially used for housing purposes but was later it extended to offices, time-shared vacation homes, and detached single-family dwellings in gated communities (Hansmann, 1991).

Cribbet (1963) narrated the history of condominium living in other parts of the world¹⁹ and mentioned that European countries already had some experience with shared ownership in the Middle Ages. In time, “splitting up of ownership of housing units became excessive, and since there were no clear rules as to repair and maintenance of the structure, disputes became common” (Cribbet, 1963:1210). Glasse and Berrisfor (2015) noted that solving this kind of maintenance disputes was the main goal of article 644 of the Napoleonic Code.

18 http://www.napoleon-series.org/research/government/code/book2/c_title04.html#chapter3

19 Cribbet mentioned the examples of co-ownership (*Geschosseigentum* or *Stockwerkseigentum*) during the twelfth century in Germany, as well as similar ones from the late Middle Ages in France and Switzerland, including reference to parts of the Napoleonic Code which over the years developed into the *réglement de copropriété*. For England he mentioned the *Coke on Littleton* policy as a way to enable ownership rights in a portion of a building. (pp.1212)

Rohan examined the new legislative foundation for the condominium regime that was enabled by the federal government of the United States. He identified some imperfections in it, specifically regarding the “failure to clarify the unit owner’s posture (and that of his household) with respect to tort liability and insurance” (Rohan, 1967: 305). Judging the condominium form of ownership as the future and best option for both multi-family and low-income homeownership schemes, Rohan raised many questions about overseeing liability problems in a co-ownership regime. For instance, he asked, “what is the nature and extent of the risk assumed as co-owner of the project and its facilities?” (Rohan, 1967: 305).

He noted that condominium regulations are silent on liability issues. In practice this means that a co-owner cannot sue the negligent one when maintenance issues arise regarding shared elements in common property. Instead, the owners’ association or the maintenance person is liable. Noting that this silence in the law can lead to deterioration and violation of statutory duties, Rohan proposed some solutions in accordance with the legal culture and the status of the jurisprudence existing in the USA. Back in the 1960s he suggested the inclusion of rules in condominium laws to allow owners to sue negligent ones for maintenance issues.

A recent edited book by Cornelius van der Merwe, *European Condominium Law* (2015), is an extensive compilation of the genesis of condominium laws in Europe, demonstrating the long history of this form of ownership regime. As explained there, the “condominium concept has three components: (a) individual ownership of an apartment; (b) co-ownership (joint ownership) of the land and the common parts of the building; and (c) membership of an incorporated or unincorporated owner’s association” (Merwe, van der, 2015:5). Accordingly, a condominium law is both a law of property and a law of association (Merwe, van der, 2015).

The thesis of Annamaria Orban (2006) is one of the few that draw a connection between condominium property law and the privatization and maintenance of social housing in Hungary. The condominium was chosen as the form of property regime during the transition period in Hungary, as elsewhere in Eastern Europe (Orban, 2006; Soaita, 2012). She traced the evolution of condominium regulation in Hungary before analyzing how households interpret the law. She looked in detail at the changes made to the 1924 Condominium Act when it was revised in the Decree Law of Condominium in 1977. She then examined the adoption of the Condominium Act of 1997 when privatization started in the social housing of the socialist period (Orban, 2006). She emphasized how remarkable it was that the Act of 1997 provided an opportunity to improve condominium governance and management. However, she noted that it did not resolve many issues, such as differences in institutional powers between the chair or president of the owners’ association and the property manager.

She also mentioned that this process created a unique opportunity to call for the professionalization of the role of property manager. Moreover, the act did not incorporate the good qualities of the more flexible law of 1924, under which condominium associations could become legal entities, entailing unitary legal representation in cases when borrowing is necessary to finance improvements. A last point of criticism is that the opportunity was lost to allow old condominiums to be transformed into other forms of property, such as cooperatives.

Owners are critical actors in condominium, but developers, property managers, and municipal authorities also play key roles within the condominium regime. Their involvement shows that multi-owned housing developments operate in a network of actors, at different phases, with certain legal frameworks that regulate the development process and others that regulate the housing complex (Blandy et al., 2010). The book by Blandy et al. (2010) presents ample evidence that condominium development and governance often encounter problems. By including articles from the UK, the USA, Israel, Singapore, Hong Kong, China, Australia, and New Zealand the book shows that conflicts of interest among actors is a recurrent problem. Various authors mentioned that while tenants are important actors, as occupants they have no formal rights of participation.

Much of the legal literature on the condominium regime deals with juridical history, ending with the modern statutory body of law on mainly dualistic condominium regimes, wherein individual and collective rights coexist. Some research deals with common-law countries and therefore with a variety of condominium regulations, though these are similar from a socio-legal perspective to condominiums in countries that under civil law codes (Blandy et al., 2010). The socio-legal perspective is an approach that institutional analysts use to study how actors and institutions interact within the condominium regime (Ostrom et al., 2006).

The IAD framework elucidates how rules affect the structure of an action-situation by clustering different types and levels of rules. "This is seen as a first step in a theory about how rules relate to the structure of action-situations, thereby affecting the way individuals behave and achieve outcomes" (Ostrom et al., 2006: 40). The types of rules shown in Table 5.2 exist within the levels that Ostrom identified, namely nested levels of operational rules, collective-choice rules, and constitutional rules (< 5.2).

In institutional analysis rules are "prescriptions that define what actions (or outcomes) are *required, prohibited, or permitted*, and the sanctions authorized if the rules are not followed" (Ostrom et al., 2006: 38). In an action-situation, the actors may have prescribed positions and authorized actions they can take. There is a set of possible actions they can take or not; actors can follow the rule, not follow the rule, or change it.

From a socio-legal perspective, rules can be written to facilitate, regulate, or constitute different actions (Edelman & Suchman, 1997). Some of them can be changed in common property resources by collective-choice rules, as will be seen in some parts of the two laws examined here.

RULE TYPE	DEFINITION
1. Position rules	Specify a set of positions and how many participants are to hold each position
2. Boundary rules	Specify how participants enter or leave these positions
3. Authority rules	Specify which set of actions is assigned to which position at each node of a decision tree
4. Aggregation rules	Specify the transformation function to be used at a particular node, to map actions into intermediate or final outcomes
5. Scope rules	Specify the set of outcomes that may be affected, including whether outcomes are intermediate or final
6. Information rules	Specify the information available to each position at a decision node
7. Payoff rules	Specify how benefits and costs are required, permitted or forbidden in relation to players, based on the full set of actions taken and outcomes reached

TABLE 5.1 Seven types of rules that may affect the structure of the situation (source: Ostrom et al., 2006:42)

RULE LEVEL	DEFINITION
Operational rules	Directly affect day-to-day decisions made by the participants in any setting.
Collective-choice rules	Affect operational activities and results through their effects in determining who is eligible and the specific rules to be used in changing operational rules. Specify the terms and conditions for interpreting, enforcing and altering operational rules.
Constitutional-choice rules	Affect operational activities and their effects in determining who is eligible and the rules to be used in crafting the set of collective-choice rules that in turn affect the set of operational rules.

TABLE 5.2 Three levels of rules in the action situation (source: Ostrom et al., 2006:46)

The socio-legal approach summarized in Table 5.3 looks into the legal environments according to the categories proposed by Edelman and Suchman (1997). With these categories in mind, property laws from Colombia and Ecuador were coded and analyzed. The research strategy is to study law as a system of procedural rules. Some rules *facilitate* the arena for action as well as procedures for dispute resolution for actors and institutions. The *regulatory* environment seeks to control processes and sanction the behavior of actors and institutions. The *constitutive* environments are expressed in articles of the law that establish when new institutions are formed and come into action, or when they cease to exist (Edelman & Suchman, 1997:479).

	LAW AS TEMPLATE FOR INTERACTION	EMPIRICAL INTERPRETATION/ PRACTICE OF LAW
Facilitative environment	Arena, tools for legal interactions and dispute resolution	Constantly transformed in the organizational context
Regulatory environment	Law seeking to control agents and institutional arrangements agent's behavior	Organizations define the meaning of compliance
Constitutive environment	Legal forms and categories, rules, principles and values	Often arise out of organizational practices and norms

TABLE 5.3 Legal environment of organizations' Integrative Model (source: Edelman & Suchman, 1997)

In that light, the horizontal property law is the rule that prescribes and defines which actions are required, permitted, or prohibited. These stipulations will be written into different parts of the law and for different actors. Rules apply depending on an actor's position regarding the governance and management of the common property resource.

§ 5.3 Agents in the condominium regime

§ 5.3.1 Agents and institutions in the horizontal property law of Colombia

Agents

Within the Colombian legal framework there is a notion of the *initial owner* whose rights and responsibilities resemble the role of the *housing developer*, even though the term 'housing developer' is not explicitly mentioned in the text of the law.²⁰ At the same time, the law gives separate treatment to two roles: the *individual owner* and the *co-owner*. This separation is reminiscent of the dualistic condominium regime explained by van der Merwe (2015). In addition to the role of the individual and the co-

20

This might be related to the legal process of incorporation or declaration of the horizontal property, because even though the developer takes care of the production process, the party who might sign the papers of declaration is the owner of the land. Although the owner of the land can be the same developer, it can instead be a trust (*fideicomiso*) who has the rights of usufruct of the land for housing purposes.

owner, the Colombian law includes the rights and responsibilities of other occupants such as *tenants*, thereby establishing a solidarity responsibility regarding the exclusive use of the apartment space.

The processes of constituting, organizing, and managing the condominium also require input from other actors that appear to be outsiders to the condominium regime. These external actors are (1) the *manager*, who can be hired by the *initial owner* or the *organized co-owners*; (2) the *municipality*, including departments such as the building permit office, the cadaster, and the property registry; (3) the *notary*, who legalizes all the various documents; and (4) the *insurance company* that will have to establish a relationship with the condominium at multiple levels, taking care of the individual property (for which insurance is not obligatory) and of the common property areas (insurance for repair in case of emergencies such as earthquakes is mandatory). Additionally, another actor is (5) the *lender*, who for some legal status in the process of the constitution of horizontal property is required to issue individual mortgages to future homeowners.

Institutions

In Colombia the main formal institutions created by law are the *regulatory documents*, which comprise the complete set of documents and information about the housing project. They include a complete table of property coefficients²¹, the document stating the rules and norms for governance and maintenance of the housing project and, finally, according to the law, the set of plans and construction details. All these documents will be part of the *declaration process*. Another formal institution is the *individual property title*, which is arranged as the development process moves forward and at such time as the social housing developer is prepared to transfer the property to a new owner. When a piece of land is built on with different kinds of houses or mid-rise buildings, the property is subdivided in condominium, thereby establishing the shares, and with each share a new property title can be established.

One of the signs of a modern condominium law is the capacity of the owners' association to appoint a legal entity or a *juridical person* which can represent the condominium in legal matters and contracts. For instance, that may occur with insurance, contracts with property management, or when it is necessary to sue an owner after defaulting on maintenance fees. According to the law, it is in the power

21

Property coefficients (*coeficientes de propiedad o alicuotas*) of the shared property are calculated in order to establish the individual property rights of one owner. The legal term in the law is "alícuota".

of the assembly of owners to choose who will represent the horizontal property as a juridical person. This person is the president of the administrative council or the property manager, if there is one. The law facilitates the process and states that to register the juridical person an *internal regulatory document* has to be approved in assembly, notarized, and registered. Therefore, the administration council will have to work and prepare the internal regulatory document to be approved in an assembly meeting. The *assembly of owners*, the management or *administration council*, and the *council for co-residency* are different institutional arrangements that the law in Colombia constitutes as one of the obligations that owners must meet in order to participate in the governance of the collective property. The *council for co-residency* (*Consejo de convivencia*) is an institutional arrangement that was included in Law 675, 2001 to instate a new internal solution to manage conflicts inside the condominiums.

§ 5.3.2 Agents and institutions in the horizontal property law of Ecuador

Agents

The system of agents in Ecuador is similar to the system in Colombia, although the language of the document or the names of actors may differ. In Ecuador, the law establishes processes for constituting the horizontal property and specifies which documents are important in this process. According to the law, these first steps are the responsibility of whoever is developing housing project. The agent involved in the first steps of horizontal property declaration processes is not explicitly named as the developer, but rather it is the step that is mentioned in the text.

In accordance with the notion of a dualistic form of tenure in condominium, the law and the bylaws refer to both individual owners and co-owners. An *individual owner* has rights over designated areas of individual and exclusive domain of the property, as well as rights as a *co-owner* over the areas of common domain of the property. The standard bylaws enacted in 1999, called the General Regulatory Law of Horizontal Property (1999) (GRLHP-1999), refers to *co-owners* and not individual owners. Moreover, the GRLHP-1999 refers to the 'user' or 'occupant' when establishing the rights and duties of the *tenant*, an agent that is missing in the general Law of 1960.

The external agents of the condominium are similar to those in Colombia, yet their roles are sometimes different. In Ecuador, these agents are (1) a *manager*, who is generally responsible for managing the representation of the juridical person of

the horizontal property;²² (2) the *municipality*, also including departments such as the building permit office and the cadaster; (3) the *notary*, who also has to legalize every document before it goes to the fourth agent; and (4) the *property registry*. The *insurance company* is also involved with the condominium regime because co-owners are obliged to get insurance to protect their common property against fire and mechanical problems with the elevators. These insurance packages include coverage for damages incurred by natural hazards such as earthquake.²³ Finally, another external agent mentioned in the law is the *lending sector* which will issue the mortgage for the low-income household. The mortgage deed will not be issued until the declaration of the horizontal property is properly arranged. As it occurs with the agent that initiates the first main documents to declare one property into horizontal property, the law mentions the mortgage as a formal institution and does not directly mention the agent involved (the banks or other financing institutions).

Institutions

The *Declaration of Horizontal Property* is a notarial document that provides all relevant information about the project. It includes the complete set of plans for the project and the table that specifies the share values, or participation quotas (*aliquotas*). This document contains the bylaws or the internal regulation (*reglamento interno*), which can be basically the same as the GRLHP of 1999 if the developer does not want to draft a new internal regulation. The *individual property title* is also an institution in horizontal property. It can be arranged once the declaration of the co-ownership regime is declared and a single title deed can be issued for a specific share value or participation quota.

Ecuadorian condominiums have a *juridical person* which can be represented by a manager or the president of the 'board of homeowners'. The administrative council or the 'board', as it is called in Ecuador, is also a group of owners elected in an assembly meeting. In Ecuador the institution in charge of keeping the records of who represents the juridical person is the Property Registry Office, but the process and the documents necessary to register the juridical person are the same as in Colombia.

22 This person can be an external manager or can be the *president* of the elected board.

23 Case-study research in Bogota and Quito demonstrates how expensive and unaffordable the insurance policy is for the co-owners. Low-income condominiums in Quito have not even thought about that. In Bogota, new low-income condominiums, which were established under the new Law 675, comply with the obligation to fund the insurance policy. As they can't raise the maintenance fee to pay for the insurance policy, they hold a series of informal events such as parties or lotteries in order to collect funds in other ways.

The legal entity of the condominium or the *juridical person* can represent the condominium in legal matters and contracts. For instance, this may involve insurance, contracts with property management, or bringing a lawsuit against an owner when defaults on maintenance fees accumulate. According to the law, it is in the power of the assembly of owners to choose who will represent the horizontal property as a juridical person; and this person is the president of the administrative council or the property manager, if there is one.

In contrast with Colombia, Ecuadorian law does not require the constitution of the *strata council*. In Ecuador, conflict resolution mechanisms are established by law, as will be explained in subsequent sections of this chapter.

§ 5.3.3 Comparison

Both national laws were analyzed, looking at their agents and institutions. Regarding the agents at whom the laws were directed, the analysis and comparison demonstrates that some agents are linked to the common property resource and others are related to it but are external, such as the professionals and organizations involved in the provision of housing. Table 5.4 below summarizes the range of actors serving as agents of the law.

Agents are discussed here by dividing them into two governance levels. The first list includes agents that are external to the future collective rights of ownership in condominium. They are either individuals or organizations; these parties are involved in housing policy, the building industry and finance, and local government development departments. Also external are the cadaster, notaries, the insurance companies, and the property managers. The last can be either external or internal, depending on whether he/she is also a paid or unpaid co-owner. When an external property manager is hired by the assembly of owners, that person assumes obligations and enters into a direct relationship with the internal actors. The table below lists the actors in clusters based on their public or private nature in the market.

At the internal level of the common property regime, there are both individual and collective actors. The laws of Colombia and Ecuador address the individual co-owner but sometimes the owner in a collective sense using the term co-owner. The Ecuadorian law is more inclined to use the term 'co-owner' (*copropietario*) than the law in Colombia. The actor that is not defined in the law of Ecuador as explicitly as in the Colombian law is the 'initial owner', the owner of the land who will subdivide the

whole into horizontal property parts. The same initial owner has important roles to play later after the main institutions of the condominium are established.

EXTERNAL	INTERNAL
Professionals and organizations	Individual
Ministry	Initial owner*
Building license department (Municipality)	Developer as co-owner
Cadastre (Municipality)	Owners (occupants and non-occupants)
Property registry (Municipality)	Tenants or users by contract
Notary	Property manager (co-owner unpaid or paid)
	INTERNAL
Developer	Collective
Lenders	
Property managers (paid, individual or companies)	Assembly of co-owners
Insurance companies	Board of homeowners**
Security company*	Strata council*

TABLE 5.4 Actors classified by position: external or internal to condominium property (source: comparative analysis of the law)

* Only in Colombian law.

** Represented by the juridical person of the horizontal property in both countries.

Both laws presume that owners will let their units; therefore tenants are part of the body of regulatory body. As investor but not occupant, the owner can transfer voting rights to the tenant or other representative as a proxy. Nevertheless, the non-present owner remains a co-owner within the governance structure. Even though he/she does not occupy the unit, that person has the obligation to be represented in the assembly of owners, even if the unit is not occupied at all.

The property manager is regulated in both laws, although the Ecuadorian law is more flexible and states that the manager can be paid or unpaid. An unpaid manager is someone from the community that assumes leadership on the board of homeowners. In Colombia, the property manager is always paid, as required by law.

The assembly of owners is the most important institution of the condominium regime since it has collective-choice powers to change some operational rules of the internal regulatory document. The assembly chooses who will represent them, electing a president as required by law. The assembly also approves in an assembly meeting the person who will become the property manager. In Colombia this will be a different actor than the president, whereas in Ecuador the property manager can be the same

person as the president or another professional. The property manager is the actor that assumes the role of juridical person of the condominium.

The juridical person is another important institution in condominium. The person who represents the condominium can sign insurance contracts, hiring contracts, and file a lawsuit if necessary.

In Colombia, another role of the assembly meeting that differs from that in Ecuador is the obligation to elect a council for co-residence (*Concejo de Convivencia*). The task of that committee is to assist in conflict resolution by seeking informal solutions.

The property regime of the condominium changes in the course of the housing provision process. While the units are being built, the governance of the external network of actors is critical. Not only are these external parties in charge of the construction process but they are also responsible for the constitution of the governing bodies and formal institutions of the property regime. The next part of the comparative analysis of the laws will concentrate on the structure of the laws and will describe the regulatory environments of each country.

COLOMBIA	ECUADOR
Formal institutions	
Horizontal property law (Law 675, 2001)	Horizontal property law 1960*
N/A	General Regulatory Law of Horizontal Property (1999)
Regulatory document**	Declaration of horizontal property**
Individual property deeds	Individual property deed
Internal regulations	Internal regulations
Manual of co-residency	N/A
Institutional arrangements	
General assembly of homeowners	Assembly of co-owners
Administrative council	President of the assembly, or board of homeowners
Juridical person	Juridical person
Condominium owners council	N/A

TABLE 5.5 Formal institutions and institutional arrangements in Colombia and Ecuador

* With amendments of 2011.

**Includes (1) the table of participation quotas adding 100% of square meters built over the common property of land, (2) architectural and infrastructure plans approved by the municipality, and (3) regulations of rights and obligations, and rules for the association.

§ 5.4 Structure of the Horizontal Property Law

§ 5.4.1 Structure of the law in Colombia (2001)

Colombia's first horizontal property law was drafted in 1948 (Law 182) but not adopted until 1958. Its adoption coincided with the sale of apartments in the first modern *unite d' habitation* complex built in Bogota. In 1985 a new law was adopted to avoid juridical problems with existing condominiums. Colombia maintained both the old and the new legal frameworks, creating a two-tier regulatory system. In 1998 a new law to regulate gated communities was adopted, as the existing regulations had become inefficient due to the complexity of the sector. Some of these developments were garden city gated communities. Others shared building structures and land so they were classified as condominiums and therefore had to comply with the 1985 law (Nader, 2002). Three years later, in 2001 the Ministry of Development presented to Congress a proposal that would fix the two- and three-tier system that had arisen under all these different laws. The open debate culminated in a single consolidated new law in 2001 (Velásquez, 2001).

The 2001 law is composed of 87 articles under four headings (called titles). Title I (art. 1 to art. 57) covers organizational issues: general definitions and objectives; the constitution, dissolution, and reconstruction of horizontal property; the definition of private and common goods; participation quotas or share values; horizontal property as a legal entity; and articles about the various governing bodies such as the general assembly, the administrative council, the manager, and the financial inspector. Title II (art. 58 to art. 62) is about the process and sanctions aimed at resolving community conflicts and addressing non-compliance with economic obligations. Title III (art. 63 to art. 84) incorporates special norms for gated communities²⁴ creating a subordinated regime for this form of property. Finally, Title IV (art. 85 to art. 87) includes general final dispositions of the law.

Facilitative environment

The facilitative legal environment consists of procedural rules that define the arena of action. For the Colombian condominium property law, the facilitative environment may be described under the following categories: (1) objectives and principles; (2) procedures for exchange of property; (3) definition of individual and common goods; and (4) procedures for conflict resolution.

1. Objectives and principles:

The law's objectives are (1) to regulate the special form of property domain where private and collective rights are expressed over the land and other common goods and (2) to guarantee security and a peaceful living environment as well as the social functions of property.²⁵ The law contains the basic principles that will guide the proclamations of the law and will guide the content of the Declaration and Regulatory Document (art. 2). Principles such as 'social and ecological function of property', 'solidarity', 'peace', 'respect for human dignity', 'entrepreneurial initiatives', and 'due process' are the priorities for setting the ground rules of the condominium regime. The 'social function of property' refers to a Constitutional principle: that individual property rights are limited and regulated by the state, and that property owners have rights but also responsibilities to society. In Columbia, urban management tools such as zoning, expropriation, and property taxes were developed under this Constitutional principle.

2. Procedures for the exchange of property:

Colombia's horizontal property law states that the initial owners will transfer their responsibilities to manage common goods to a newly formed owners' representative body after 51% of the property shares have been sold (art. 24 and 52). How management is carried out before 51% of the property is sold is unclear. The initial owner, who in some cases is the developer, owns most of the shares of property during this stage. There is no need to call an assembly meeting if the developer can make majority decisions by itself.

After 51% of the units have been sold and the responsibilities have been transferred to the assembly of owners, the developer remains part of the owners' association until the sales are completed. The path is clear at this point: the co-owners have to wait until the initial owners have transferred their collective rights and collective decision-making

powers. At the same time the developer depends on the co-owners' cooperation in fulfilling their responsibility for governance and maintenance costs as long as the developer remains a co-owner (i.e., while finishing the sales).

One obligation of the general assembly of owners is to elect a manager; however, a provisional manager will have been hired by the developer in the interim (art. 52). The general assembly then has to decide whether to continue with the same manager or to hire a new one. New duties that fall to the collective owners have to be managed while settling the transaction processes with the new owners. These are moments when the facilitative environment of the law merges with the constitutional environment. To be able to take action and collectively start the decision-making process at the governing level, some formal institutions and new institutional arrangements have to be taken care of. There are no sanctions for the initial owners in the event they would fail to comply with the rules for transaction processes.

3. Individual and common goods:

*Colombia: private goods or goods of exclusive domain, common goods and non-essential common goods.*²⁶

Art. 16 specifies that private goods, or 'goods of particular domain' have to be identified in the regulatory document or declaration and in the plans of the complex. The article also explains that the property of a private good implies co-ownership of the common goods of the building in proportion to each owner's individual participation quota.

Additionally, this article circumscribes the rules in the regard to the roles for the municipality, and specifically for the cadaster, in relation to what is understood as a private good. It states that property taxes will be calculated and charged individually, in proportion to the participation quota. Owners of private goods have collective obligations and these are clearly linked to the fact that the property is a small part of a bigger building.

The term 'non-essential common goods' refers to parts of the collective property that, because of their location in the building, can be assigned in exclusive domain, such as the backyard or parking lots. Conversely, examples of essential common goods would be the staircase, walkways, etc.

26

In Spanish: *bienes privados o de dominio particular, bienes comunes, bienes comunes no esenciales*

4. Procedures for conflict resolution

Conflicts under the condominium regime can come from various sources; some of them may originate in the relationship to the management, others in the maintenance of the property (Orban, 2006). The law suggests that to manage internal conflicts, the administrative council will constitute the council for c-residency (*concejo de convivencia*) consisting of three co-owners who are supposed to resolve conflicts using their own personal skills and dialogue. The members of this committee are not empowered to impose sanctions.

Constitutive legal environment

The constitutive legal environment relates to the provisions that allow instatement of the main institutions mentioned above, in addition to the constitutive rule that gives voting power to owners. Regarding this environment the following categories of constitutional rules were identified: (1) bylaws; (2) assembly of owners; (3) juridical person; (4) voting rules.

1. Condominium bylaws

The bylaws are contained in the *regulatory document*. Art. 3 defines it as ‘the statute that regulates the specific rights and obligations of co-owners of a building or a housing complex under the horizontal property regime’. Article 4 states that the constitution under the horizontal property regime, a notarial public instrument, is recorded in the property registry, whereby the juridical person of the condominium is born.

Then in an extensive and detailed text, art. 5 outlines the minimum contents of the ‘deed’ (*escritura*), bylaws, and regulation (*reglamento*). In general, the bylaws give the name of the owner (initial owner), the name of the building, and information about the land on which the buildings in condominium are located, including the registration folios of each individual unit, jointly called goods of individual domain (*bienes de dominio particular*). The registration of these goods of individual domain has to conform to the blueprints, or to both the architectural and construction plans that had been approved by the municipal entity. The same should occur with regard to the common property elements, including those that are essential and those that have been assigned to other uses in the building. The bylaws also specify the ‘co-ownership

quotas' (*coeficientes de copropiedad*) and modules of contribution (*módulos de contribución*).²⁷

In addition to the basic rules defining the individual and the common property, this article mandates that the bylaws will contain regulations regarding 'organization, management, and control of the juridical person that is born under the administration of this law and the rules that govern the organization and functioning of the building or complex'. To draft these regulations, developers follow the articles included in the same law about governance and management of condominiums. But art. 5 contains three extra paragraphs in which it is clearly stated that regulations cannot determine what is not allowed under this law, and that any internal regulation can overrule any of the property rights regarding a piece of individual domain.

Article 6, in accordance with article 4, states that to notarize the bylaws it is necessary to submit the blueprints or plans (architectural and engineering plans) with the building license. And if the drafted bylaws diverge from the submitted plans, the notary should make a note of the discrepancies.

2. Assembly of owners

.....

The assembly is constituted by the owners of private goods. If they cannot attend, the owner can delegate their responsibility to the tenant or another person. According to the law, decisions made in the assembly are binding for every owner, including the absentees, and all other users and occupants of the building. When constituting the assembly, the law prescribes twelve specific functions. Some of these are related to the establishment of formal institutions; for instance, they may require elected members to serve on the strata council or the administrative council. In summary, this law (1) constitutes the governance body and defines when and how many times can it meet, (2) includes details and rules on taking minutes, and (3) mentions other general prescriptions on how to run an assembly.

27

Modules of contribution (*módulos de contribución*) are defined in art. 31, explaining that every internal regulation of horizontal property should regulate how some of common goods and services in the common property, that are not intended for general use because of their nature and location, will be managed and how costs of use and maintenance of these elements will be charged to co-owners.

3. Juridical person

At the first assembly meeting of co-owners, decisions will be made on hiring an external administrator or appointing a member of the administrative council as the legal representative of the juridical person. The juridical person is the institutional arrangement that holds collective powers. That person is responsible for signing contracts with other internal employees in charge of maintenance, or with maintenance companies for the repair of elevators and water pumps, for garden maintenance, or for security. The objective is to 'correctly and efficiently administer the common services and goods, and to manage issues of common interest to the owners of private goods to comply with the law' (art. 32 to art. 36).

According to article 8, it is the mayor's responsibility to keep the records and certify the existence of horizontal property juridical persons. Condominiums elect or reelect the president of the assembly meeting, and in this meeting the property manager can also be reappointed or changed. Then the person whose name is under the legal entity will change too. And therefore, to keep the registration of the legal entity current, the records in the municipal system have to be updated every time there is a change in who represents the common property juridical person. To constitute a juridical person, it is necessary to present the notarial document of the bylaws, which is deposited at the property registry office, plus the documents such as the minutes of the assembly meeting that validate the decision.

4. Voting rules

Participation quotas determine the following: (1) the proportion of rights of each owner of private goods over the common goods of the building; (2) the percentage of participation at the general assembly of owners; and (3) the modules of contribution by which each owner will contribute to common expenses.²⁸ Table 5.6 shows the various points at which a majority is necessary, and votes will count in terms of the percentages or shares held by owners. The categories were constructed to allow comparison with Ecuadorian law. In Colombia, no matter what kind of change is envisioned, the voting rules are the same: in order to approve a rule change, agreement must be reached by 70% of the ownership shares. This is not the same as 70% of the owners. However, in affordable housing projects, since all dwellings tend to be of the same size, the effect of this rule is similar to the practice of using the number of owners, as in other condominium buildings.

	VOTES IN PROPERTY SHARES
Quorum in assembly meeting	51%
Approval of a budget, and monthly fees, or extraordinary fees	70%
Reconstruction of the building (when the damage is over 75%)	70%
Reforms to the declaration documents	70%
Removal of non-essential common good	70%
Decisions to include individual meters for utility bills	70%
Change of use of a particular domain good	70%
Liquidation and dissolution of horizontal property	70%

TABLE 5.6 Majority rule required in assembly meetings in Colombia

Regulatory legal environment

Maintenance fees are generally collected on a monthly basis. Art. 30 of the law prescribes what to do when a co-owner gets behind. First, interest can be added to the outstanding balance and charged monthly until the owner makes the payment. Part of the protocol to sanction non-payers is to post a list with the names of those in arrears in places where it can be seen by all co-owners.

When a co-owner is in debt, the person who represents the juridical person of the horizontal property can start due process to demand payment. Art. 48 says that under a competent judge, the juridical person representing the horizontal property can file suit. All the necessary documents to prove the case must be submitted, including the minutes of the assembly meeting at which powers were given to the legal representative of the horizontal property. The law recommends using the executive process instead of trying other conflict resolution mechanisms.

Art. 49 regulates how the property manager, the accountant, and individual owners can appeal the general assembly's decisions if these do not comply with the law or with the internal regulations of the horizontal property.

Art. 58 to 62 regulate what to do when owners do not follow other rules. This part of the law pertains to those rules that are not related to the maintenance fee or other non-money-related obligations, such as attending the assembly meeting, or operational rules regarding the use of common areas. Other non-monetary rules include those about the hours when loud music is allowed at gatherings and parties, about keeping pets inside the apartments, and about the preservation of architectural features of the facades or the structure.

Every horizontal property regulation can stipulate its own sanctions for these non-monetary obligations, although the scope of such sanctions is restricted by the law. Sanctions can take three forms: (1) posting a notice naming those who have broken a rule; (2) setting fines for every breach; and (3) restricting the use of non-essential common goods, such as recreational zones, but never essential ones like the elevator or stairways. Sanctions have to be specified in the internal regulations and approved in the assembly meeting.

To sum up, the Colombian Horizontal Property Law has clearly defined three legal environments, each encompassing a particular regulatory objective. The facilitative, constitutive, and regulatory environments take into account both the external actors that are involved during the housing provision process, including the key position of the initial owner, and the internal actors such as the co-owners.

§ 5.4.2 Structure of law in Ecuador (1960)

In 1960, with a conservative government in power,²⁹ the Ecuadorian president issued an executive decree to adopt the horizontal property regime. According to the ‘exposition of motives’³⁰ for the decree, the condominium regime is meant to address the need to regulate the property of flats or apartments. The need arose because the Civil Code only dedicated a few articles to this form of property. Also, the motivation says that the Civil Code did not provide enough scope to allow more businesses of this nature to develop. The first proposal was submitted to Congress in 1954, without passing the second debate for definitive adoption. It was not until 1960 that both the national housing institutions (BEV & JNV) and the national pension funds institute (later, in 1970, the IESS, Ecuadorian Institute for Social Security) asked the president to officially adopt the horizontal property regime in order to resolve the emerging housing need (Personal interview, Sixto Duran Ballen, 2011).

The motivation goes on to say that the law is necessary to address the emerging quantitative and qualitative housing deficit. This implies that the country needed a legal framework suitable for the promotion of more affordable housing for ownership. The horizontal property law’s ‘exposition of motives’ mentions the urgency of putting

29 The president was Camilo Ponce Enriquez, founder of the conservative party PSC (*Partido Social Cristiano*).

30 Exposition of motives, Horizontal property law, 1960. Decree Emergency Law No. 08, Official Registry no. 1069.

the necessary regulations in place, in order to make transactions with future co-owners and to protect the investment of the pension funds that were already building housing for their associated workers.³¹

The Law of 1960 contains 25 articles, but these were not codified until almost forty years later, in 1999.³² Codification was mandated by article 11 of the 1960's law to create a standard regulatory body 'to specify reciprocal rights and duties of co-owners'. The standard regulatory law was adopted in 1999 as the General Regulatory Law of Horizontal Property (GRLH-1999) with the objective of 'establishing principles and norms' that will command all goods in condominium or horizontal property. According to article 11 of the law (1960), if the condominium organization does not create an internal regulatory body, the GRLH-1999³³ will apply. The regulatory law contains 65 articles. Therefore, there are two legal documents to consider: one that constitutes and facilitates processes to declare that a building consists of horizontal property; and another that regulates the horizontal property regime, specifying both individual and collective rights and setting forth the roles to be performed by the association of owners and their representatives. Both legal documents together make a body of regulations comparable to the Colombian horizontal property law.

The Ecuadorian law was amended recently, in September 2011. Representatives of commercial condominiums, in conjunction with real estate construction companies, lobbied the national assembly to amend some of the articles of the law of 1960. Specifically, these groups asked for (1) the modification or elimination of the veto power of one single owner when repairs to the building are necessary; (2) the interpretation regarding the form of association in relationship to tax obligations; and (3) the assurance of due process for collecting unpaid common expenses. These amendments were adopted as part of the reform of the horizontal property regime. Changes to the law were made with the purpose of clarifying institutional environments regulating constitutional co-ownership rights such as voting powers and to introduce sanctions that were missing in the original law.

31 Emergency Decree March 15, 1960, Horizontal property law, R.O.

32 The first regulatory body was adopted by Executive Decree 1708, August 5th, 1998, Official Registry 378, during the Presidency of Jamil Mahuad. This decree was revoked by another Executive Decree issued by the same President in 1999: Executive Decree 1229, August 27th, arguing that previous norms do not comply with current needs (exposition of motives included in the law).

33 Name in Spanish is REGLAMENTO GENERAL DE LA LEY DE PROPIEDAD HORIZONTAL

Facilitative legal environment

The facilitative legal environment in the Ecuadorian condominium regime consists of four categories that are the same as under Colombian law. These are (1) objectives and principles; (2) procedures for exchange of property; (3) definition of individual and common goods; and (4) procedures for conflict resolution.

1. Objectives and principles

The Ecuadorian law (1960) does not include general objectives and principles such as peace or due process as it is included in the Colombian Law. The Ecuadorian context in the 1960s was different. Fifty years ago, when the condominium was a new phenomenon, the law needed to explain to agents and institutions under what conditions land and buildings can be declared horizontal property and how that regime should work.

At the beginning of the text, article 1 of the law specifies that:

Property in the form of an apartment, a single-family one-story dwelling, or a group of houses, when they are independent with an access from the street or other communal spaces, can be property of different owners.

This passage is a clear reference to Ecuador's Civil Code.³⁴ The law mentions the individual title deed as the document that will state how the property will be identified in terms of its location in the building. Moreover, the law clarifies that 'ground floor' is different from the first floor, as the ground floor corresponds to areas located at street level. Basically, these initial articles clarify the physical arrangement of the property, providing an almost self-evident description of the physical property.

Although the 1960 law did not include any general principles, the General Regulatory Law of Ecuador (GRLHP, 1999) filled this gap. It mentions the principle of solidarity between co-owners and other occupants. Solidarity is encouraged among owners and tenants and other occupants by making them responsible for responding to possible

34

Ecuador, Civil Code, Art. 895 in Eguiguren (2008).

damages and violations to the law regarding issues of condominium administration and maintenance.³⁵

Whether in the primary text or in a separate regulation, both the Colombian and Ecuadorian laws included some general principles and definitions of the property regime. These passages are crucial to the production of condominium housing as they are addressed to the agents and institutions of the housing system as a whole. The intended audience includes initial and future owners, occupants, and other actors with a stake in horizontal property, since general principles need to be read and enforced by the various agents along the trajectory of the provision of housing.

2. Procedures for the exchange of property

The Ecuadorian horizontal property law does not explicitly regulate the time frame when the housing developer will meet with the owners holding property rights in common, unlike Colombian law which requires that step when co-ownership reaches 51%. Nevertheless, the law establishes some facilitative processes. Furthermore, it makes clear that after the construction of the building is completed, documents such as the plans of the building identifying which land and spaces are held in common and which are exclusive should be registered with the property registrar and the cadaster.³⁶ This facilitative environment is designed with the developer in mind. It ensures the existence of information and records of the building to support the future exercise of individual and collective property rights. In the case of Ecuador, the law's facilitative environment ensures that the condominium has been properly declared, a process that involves four agents: the social housing developer, the property registry, the cadaster, and the building license department.

The same initial principles apply at this stage in housing provision. However, the articles defining and explaining the physical property over which owners can exercise their rights and duties are both facilitative and regulatory environments, dealing with the rights and duties tied to the physical collective property. The notion of individual and common goods is explained within the facilitative environment with respect to the consumption stage, but it is specified during subsequent steps leading up to the production stage, particularly the steps of architectural design and the drafting of declaratory documents.

35 Ecuador, 1999. General Regulatory Law of Horizontal Property, Art. 3.

36 Ecuador, Law of Horizontal Property, 1960-2011. Art. 10

3. Individual and common goods

*Ecuador: individual common goods, general common goods, and exclusive goods.*³⁷

Each owner, while being the exclusive owner of the flat or commercial space,³⁸ is also a co-owner (*condómino*) of goods designed for common use.³⁹ When the law was revised in 2011, it clarified the definition of 'common goods' for cases when the dwellings are designed as a complex of different residential blocks and when the understanding of the common areas is ambiguous. The law explains that 'general common goods' correspond to every good that is useful to all co-owners, also allowing for the use of the exclusive goods. There are also 'individual common goods', which are goods that correspond to common areas assigned in the declaration or by an assembly meeting to owners of each tower.

This comparison of the two laws helps to refine some basic concepts underpinning the definitions of individual and common goods in the condominium regime. What the law leaves unsaid is that the main 'common good' is the plot of land. The urban and architectural design of the project mentions 'individual or private domain goods' such as the interior of the housing unit. If the unit has a garden or terrace for private use and with exclusive access, the garden area will be a 'common good of private domain'. Common and individual domain areas are all quantified in square meters and converted into shares. These numbers are useful for calculating the final price of the housing units and to constitute the table of participation quotas of the declaration document.

4. Procedures for conflict resolution

In Ecuador, the law of 1960 makes no institutional arrangement for conflict resolution such as the council for co-residency (*concejo de convivencia*) in Colombia. However, the General Regulatory Law of 1999 states that to resolve any controversy among co-owners and users (tenants), the parties can be called to take part in a short verbal conciliatory process under the direction of any administrative body of the horizontal property regime.⁴⁰ Issues raised by co-owners and the controversies between them can also be addressed under the law of mediation and arbitration, according to the horizontal property law.

37 In Spanish: *bienes comunes individuales, bienes comunes generales, bienes exclusivos*

38 The condominium law applies to both residential and commercial properties.

39 Art. 2

40 Ecuador 1999, General Regulatory Law of Horizontal Property, Art. 63.

Constitutive legal environment

The constitutive legal environment of the condominium regime consists of those parts of the law that allow or mandate the constitution of the following formal institutions and organizations. These are (1) bylaws; (2) assembly of owners; (3) juridical person; and (4) voting rules.

1. Condominium bylaws

Basically, the bylaws in condominium comprise a set of documents that together become part of the internal constitution or statute of the condominium. This broader set is called the declaration of horizontal property (*declaratoria de propiedad horizontal*). Art. 10 of the law says that once the building in horizontal property is finished, the plans explaining 'with clarity' both common areas and spaces of exclusive property will be recorded in a notarial document and later registered in the cadaster. One copy of the plans will be recorded in the property registry and another in the cadaster. The article does not mention whether a copy should stay with the future co-owners.

Together with the plans, a set of internal regulations are written by the developer, and these should be registered with the property registry office too. Art. 12 of the law prescribes the content of the internal regulations:

Rules for management and conservation of common goods, functions that correspond to the assembly of co-owners, rights and obligations and form of election of the property manager, allocation of management fees among co-owners, and everything that impinges upon the interests of co-owners and of maintenance and conservation of the building. (art. 12)

The internal regulations are registered initially by the developer. Later, when the assembly of owners has assumed the powers of collective ownership, the internal regulatory documents can be modified when a two-thirds majority of the property owners approves the changes at an assembly meeting.

2. Assembly of co-owners

The law in Ecuador mentions the assembly of co-owners in art. 12, cited above as the principal body with the obligation to adopt the rules and capable of changing some rules too. The law of 1960 explains that owners constitute an association that will be in charge of the administration of the common goods, referring to the General Regulatory document (GRLHP) as the main guidance for the association of owners' activities. In 1999, the GRLHP included the chapter on governance bodies and renamed the association of owners as the assembly of co-owners. Unlike Colombia's law, in Ecuador the law stipulates that owners have the right to vote in assembly if their administration fees are paid.⁴¹

In the regulatory documents of 1999, art. 20 in chapter V on the rights and obligations of co-owners states that owners have the obligation to attend the assembly meeting and can use their freedom of speech through the right to vote, ask questions, or use any other powers given to co-owners as specified in the law.

3. Juridical person

In Ecuador the process of creating the records to certify the existence of horizontal property is similar to the rules in Colombia, but the inscription takes place in the property registry office, not at a municipal planning or cadaster department. The property registry office requires more than a copy of the declaration process. It also requires the new regulatory document that has been revised and approved by the assembly meeting. The person designated as the property manager, either paid or not paid, represents the juridical person. The minutes of the assembly meeting, which are signed by co-owners when the decision has been approved, is a binding document that will accompany the documents that need to be registered in the property registry office.

4. Voting rules

Voting rules are specified in separate articles in the law and within the internal regulatory law. Different rules may apply, depending on which rule is being enacted or changed. Table 5.7 summarizes the different voting rules depending on the issue for which approval is sought.

41

General Regulatory Law of Horizontal Property (1999) Art. 39

	% SHARES
Quorum	51%
Approval of a budget and common expenses	51%
Approval of a budget for extraordinary fees	2/3 of owners
Modification of facades and other elements of the common goods	75%
To remodel and make improvements inside the private unit without affecting the structure of the building	60%
Dissolution is not allowed while the buildings still exists	-

TABLE 5.7 Majority rule required in assembly meetings in Ecuador

Regulatory legal environment

One of the main obligations of co-owners is to pay for management and maintenance activities on the common property. The amount of the fee is approved in the assembly meeting according to a maintenance budget and then divided according to participation quotas. This decision, which is also recorded in the minutes of the meeting, is legally binding (*titulo ejecutivo*).

1. Sanctions

Article 13 of the law of 1960 is one of those articles that had been modified in 2011. The amendment makes it clear that the decision of the assembly meeting can be enforced by law and that, if necessary, the co-owner can be sued if he or she is behind in payments. The law prescribes that the decision to sue can be enforced when the owner is behind by two or more payments.

Regarding other rules on the use of the common property, art. 12 of the regulatory law of 1999 prohibits various uses of common spaces. For instance, it is not allowed to hang objects or clothing from the facades, to obstruct walkways, to install machines that make noise, or to use the apartment in a way that is not specified in the regulations. In total, the article contains twelve rules. In addition, the assembly of owners can impose rules for the management, preservation, and maintenance of the goods constituted in horizontal property, setting these forth in their internal regulatory documents. Unfortunately, the law does not mention how to enforce or sanction owners if they do not comply.

Article 19 treats sanctions, but only mentions the rule regarding what to do when an owner is behind in payments.

2. Accountability

It is the role of the president of the board or the property manager (if they are different persons) to oversee fulfillment of the obligations. Article 60 of the regulatory law of 1999 describes the responsibility of the property manager, assigning him/her (under point h) the responsibility to sanction owners that do not follow the rules or do not comply with the decisions made in the assembly meeting regarding the use of the common property. The fines thereby collected will be deposited in the common reserve fund of the horizontal property.

§ 5.4.3 Comparison

A facilitative legal environment is a legal context that includes “passive procedural vehicles and forums that organizations may mobilize to resolve disputes, to structure their relations with other organizations, to govern their employees, to influence the behavior of regulatory agencies, and to gather information” (Edelman & Stryker, 2005). The horizontal property law creates a facilitative environment when it:

- explains objectives and principles designed to influence behavior, under which the regime will be governed;
- includes passive procedural rules for the exchange of property;
- defines individual and common goods over which owners have rights and duties; and
- establishes procedures for conflict resolution.

Comparing these two laws from the perspective of Ostrom’s, it can be said that the objective of the facilitative environment of both Colombia’s and Ecuador’s laws, is to define the boundaries for common property resource governance and management. The facilitative environment is set forth in the law intended to be read by the *initial owner* and by *owners* giving thereby treating both parties as *co-owners*. Additionally, other agents are mentioned under the heading of the facilitative environment, including municipal agents issuing construction licenses, the cadaster, and the property registrar.

Under the definition of individual and common goods, the Columbian and Ecuadorian laws use different terminology but refer to the same concepts. However, the Colombian law makes one additional distinction that actually proves useful for determining sanctions in the regulatory environment. The Colombian law distinguishes between non-essential and essential goods. For example, a non-essential good is a garden area

or the common room for assembly meeting. An essential good is the elevator or the stairs, or the walkway to access to the individual property. This distinction is not made in the Ecuadorian law.

Other important differences concern the rules for the exchange of property. The Colombian law clearly prescribes the moment when it is compulsory for the initial owner to install provisional property management. Furthermore, when 51% of units are sold, the initial owner has to call an assembly meeting and constitute the other important institutions of the horizontal property regime. These kinds of rules regarding provisional property management and calling an assembly meeting are not included in the Ecuadorian law.

The constitutive legal environment corresponds to sections of the horizontal property law that will shape the institutions of the property regime by organizing roles and governance. The main principles have to be defined and the physical areas have to be described by the facilitative environment documents. The law subsequently establishes specific rules to constitute formal institutions such as the horizontal property documents or bylaws, the purchase agreement, and the individual title deed. The law requires the constitution of institutional arrangements as well as of formal institutions for the provision of housing.

First, during the production process, the *declaration* is drafted, including land measurement details, architectural and engineering drawings, and the regulatory document containing the participation quotas or value shares (*alícuotas*) in relation to the total number of square meters in the structure. Second, during the exchange processes and after the declaration of the regime has been registered with the property registry, it is possible to draft *purchase agreements* that later will become *individual property titles*, at which time *mortgage deeds* will be issued. The declaration of the property regime also includes the bylaws of the new owners' association in condominium.

The *declaration* document under which property is divided into a condominium is drafted by the housing development agents, or the initial owners as these agents are known under Colombian law. This document includes the drawings and engineering details of the building, differentiating between individual and common property elements. Rights and responsibilities of individual and exclusive use of the property are part of a constitutive and regulatory environment of the law and are specified in this document. In Colombia this document is called the *regulatory document* while in Ecuador it is called the *declaration of horizontal property*. Both include the internal regulations under which the condominium will be governed. It is also an obligatory document to be able to start sales.

Various articles of the law require distinguishing individual from collective goods, both at an early stage in the design and plans and later on in the declaration documents. This information forms the basis for calculating value shares or property quotas. These shares are the means by which votes are distributed among owners in condominium governance. In Bogota and Quito, the voting arrangements are usually based on participation quotas as a way to express individual rights in collective property matters.

Voting rules in Colombia are the same no matter what the decision is about. At least 75% of the quotas⁴² have to concur in order to reach a decision. In Ecuador, the voting rules change depending on the issue being decided on, as shown in Table 5.7 above.

Regulatory Legal Environment

This legal environment is the document that sets the sanctions and enforcement procedures. Laws create a regulatory environment “invoking societal authority over various aspects of organizational life” (Edelman & Suchman, 1997: 483). To understand the regulatory environment of the horizontal property law, it is necessary to turn to examples of compliance, or to see the law in action. However, for this part of the analysis, both laws were examined in terms of their regulatory powers that can or cannot sanction or oversee compliance with maintenance and governance arrangements.

Both laws contain rules to sanction situations such as non-payment or non-participation by the owner. All rules on sanctions or conflict resolution apply once the owners are living in the condominium. They do not apply during production; for example, under Colombian law, there are no sanctions if the initial owner fails to establish the provisional property management or if it fails to call the first assembly meeting.

Under both laws the sanctions can escalate. For example, in Colombia the council of co-residency (*consejo de convivencia*) will intervene before the conflict goes to the property manager, the president, or to court. Although it is not regulated, something similar for conflict resolution is included in the Ecuadorian law to solve conflicts before it goes to court. Both legal frameworks presume that non-compliance with agreements can be addressed through conflict resolution mechanisms before imposing fines or other economic or legal sanctions.

42

The table of participation quotas must be submitted in order to get approval for the project’s construction license from the municipality. For example, if a building has a total of 1000m² of floorspace, and a standard affordable dwelling has 50m², the owner has individual rights in an assembly meeting that carry a weight of 0.05 in votes; similarly, the total costs of maintenance are divided by this share of ownership.

§ 5.5 Conclusion

In this chapter the horizontal property law was analyzed as the main formal institution of the condominium regime. Even though other rules apply to the system of condominium housing provision, for instance subsidy regulations and municipal license norms, the horizontal property law is the body of regulatory documents that prescribes who can be involved as agents in the common property that will be constituted, self-governed, and maintained.

The research question investigated in this chapter concerns which agents and institutions are regulated by the law, how the law is structured, and which similarities and differences exist between the laws of Colombia and Ecuador. The material presented above has demonstrated that, in general, both countries clearly define the position of the different actors involved. For example both horizontal property laws define the role, rights, and obligations of owners as individuals and as co-owners.

Some differences were observed between the laws. It was found that the Colombian law regulates the moment when the assembly of owners should be first constituted, thereby inaugurating the main self-governance institutional arrangement. Placing these observations in Ostrom's framework, the common property resource in Colombia has a collective-choice rule nested into a constitutional one, a very important condition for creating the governing body of the condominium. In Ecuador, in contrast, the collective-choice rule for constituting the first governing body is not defined, thereby leaving ambiguity about the process when the condominiums are new. For old ones, however, there is a collective-choice rule that owners can use to call an assembly meeting if necessary.

The condominium is an interesting example of a common good. Since it is produced by developers, the rules are not constituted or written by those who are going to govern and use the building or housing complex. In that sense, Ostrom's principles have proved useful but only to some extent, since they do not take into account the complexity involved in the housing provision process. The principles of a common property resource in Ostrom's perspective, assume that the rules are designed by those who are going to implement them. Although rules are not drafted by the 'users' of the resource, the IAD framework as presented earlier (in chapter 2) includes the rules as these apply to some of the three variables influencing the outcomes of an action-situation. In this case, the main variable is the law of horizontal property.

In terms of structure, and in accordance with condominium regimes elsewhere in the world, the two horizontal property laws compared here are similar. As expected,

both countries regulate the general aspects: individual property rights; the common property resource; governance and management. However, when observing the law through the housing provision states, the Colombian law recognizes collective property transfer, a process that is not covered by rules in the Ecuadorian law.

Bringing Ostrom's (1990) framework to bear on this comparison, similarities come into view regarding the governing norms. In particular, the two laws are similar with regard to the collective-choice rules and the obligations to use the internal regulations as the main constitutional body that can be modified according to the agreements made in an assembly meeting. But there are also differences. Voting rules are straightforward in Colombia, where 70% of the participation quotas is needed for a simple majority in every instance. In Ecuador, in contrast, the voting rules vary depending on the rule or action to be adopted. The effect of these differences warrants further examination in other analyses, but in the present investigation it may indirectly influence some of the variables, as will be shown in the next chapters.

Regarding sanctions, the Colombian law does not impose any 'graduated sanction' on the initial owner if he/she fails to transfer the property, or if the regulatory document submitted to the property registry contains mistakes.

In both countries the bylaws of condominium, the most important rules in play, are drafted without participation or approval of the co-owners. That issue has already been noted by Blandy et al. (2010) as a critical moment in the condominium property regime.

To conclude this chapter about the horizontal property law, it remains to say that these rules were written for the actors, either external or internal, within the condominium regime. Embedding the comparative analysis in Ostrom's self-governance framework it has made it possible to identify the various environments and actors involved.

Part III

The next two chapters deal with governance, considering how actors perceive the maintenance problems and how the formal rules are actually followed. In accordance with Ostrom's framework, this research is based on the assumption that informal institutions or solutions will be developed by the actors involved, who thereby change the rules that have been established or reinterpret the law.

Chapter 6 presents the qualitative results of the focus groups that were attended by professionals and actors from public organizations. The analysis expands on how they perceive the problems encountered in the housing policy network due to deterioration and their own roles in that process.

Chapter 7 presents the results of a survey conducted among a sample of low- and middle-income condominium owners. The aim was twofold: to understand their perception of the maintenance problems; and to find out whether they followed self-organization strategies in the condominium regime or developed new rules ones, either formal or informal.

6 Professionals in provision of affordable condominiums

§ 6.1 Introduction

Ostrom's work on the governance of common resources demonstrates that theories of collective action are useful to study certain variables but not the whole system. Her argument is that theories of collective action do not take into account "the process of accretion of institutional capital" (Ostrom, 1990:190). Therefore, policy analysis draws attention to how the group of actors, both internal and external, experience incremental learning in a process of self-organization. As Ostrom found, inadequate attention has been given to "how the activities and policies of external political regimes can affect the level and type of self-organization to achieve collective benefits" (Ostrom, 1990:190). Any theory of self-organization and self-governance must therefore take into account the strategies of external actors when explaining behavior and outcomes.

This chapter builds upon Ostrom's theoretical groundwork in policy analysis to examine the behavior of the external actors in the affordable housing policy network of Bogota and Quito. Specifically, these are the professionals involved in this particular housing sector. The policy networks to which they belong are in charge of producing condominiums for low- and middle-income families. In light of the comparative analysis of the legal environment in the previous chapter, it is clear which external actors are recognized in the property law. Nonetheless, some other actors are not regulated by the law, even though they participate in the network and have to follow the rules too. Unregulated actors, such as social managers, have a direct relationship with the condominiums and thereby have a direct bearing on the incremental learning about condominium rules and self-organization.

Professionals in the policy network are considered external actors because they are not co-owners. Instead, they interact through either collective-choice rules or operational rules, both of which are important to the governance of low-income condominiums. The exception is the housing developer, who is both external and internal, depending on the phase of housing provision in which he/she is positioned. As long as the

developer is still selling the units, that company or individual is a co-owner and has to follow the same rules as the co-owners.

Four research questions will be addressed in this chapter:

- 1 How is the policy network composed and what are its characteristics?
- 2 How do professionals perceive deterioration processes in condominiums? And how do they deal with deterioration? Do they take recourse to the property law?
- 3 What are the similarities and differences between the policy networks in Bogota and Quito?
- 4 Does the network approach help explain collective action in the policy network?

Exploratory interviews were held with key external actors in both Bogota and Quito. The responses helped to identify who belongs to the network, and the identified individuals were invited to take part in the focus groups. Focus groups were planned and held in both Quito and Bogota in the fall of 2012. The selected individuals were invited to spend one morning with other people who were involved in housing provision. For consistency, the group interviews, questions, and methodology were the same in both research settings. The focus group methodology used for these sessions was explained in a previous chapter (section 3.4). The group interviews revolved around two activities. The objective of the first one was to observe the composition and characteristics of the network. The second one was intended to observe how actors perceive the causes of and solutions for deterioration of the common property.

Section 6.2 reviews the literature on network governance. Section 6.3 responds to the chapter's first and third research questions by comparing the members of the policy network in Bogota and Quito and identifying the similarities and differences between the two networks. These comparisons are based on the interviews and focus groups, and some passages from the narratives are presented as evidence.

Section 6.4 addresses the other aspect of the first question, namely the characteristics of the networks in Bogota and Quito. The discussion is based on the network perspective and data collected in the first activity of the focus groups held in both cities.

Section 6.5 responds to the second research question by describing how actors perceive the deterioration path of dwellings built for low-income households. During the focus groups, the participants were presented with a case in the form of a vignette. They were then asked a series of questions in order to find out when they thought deterioration problems were likely to begin.

The chapter closes by drawing some conclusions and responding to the fourth question. These concern the role of the different actors, how they perceived the problems, and which solutions they see for Quito and Bogota.

§ 6.2 Literature on network governance

The rise of the network society prompted the emergence of the network governance perspective. From that perspective, government plays neither a hierarchical nor a centralized role in the implementation of public policy (Bortel, van, 2016). A network perspective is useful for understanding governance that is connected to a specific field of public policy in which the actors may be public, semi-public, or private. A 'policy network' consists of actors in their institutional and organization contexts. The networks have the capacity to collaborate, and that capacity will influence the outcomes of policy implementation (Bueren, van & ten Heuvelhof, 2005; Bortel, van & Elsinga, 2007; Kickert et al., 1997). This was a novel perspective when it emerged in the 1990s, since it connected the analysis of public policy processes with the fields of political science and organizational theory. Investigators started looking at "the distribution of power and dependencies, organizational features and interorganizational relations" (Kickert et al., 1997:1). It has since been used to understand policy networks like those operating in areas such as agriculture, social security, health, and housing (Kickert et al., 1997:2).

This perspective lends itself to integration into Ostrom's framework. Like Ostrom, other scholars working on networks also seek to understand institutional change, particularly how actors adapt institutions to specific situations to achieve policy goals. If problems arise in the policy network, and it can be made more effective or efficient, then the question is how to improve the situation by managing and steering the network. Ostrom (1990) and Kickert, Klijn, and Koppenjan (1997) recognized that existing networks have self-regulatory practices that are "based on knowledge of local circumstances, and shared rules and perceptions" (Kickert et al. 1997:51). Therefore, in order to improve the outcomes, the internal practices and social capital within the networks should be acknowledged, without imposing unnecessary new rules to replace existing ones.

Whether public or private, every party has its own interests and goals (Rhodes, 1997). Relationships in a policy network environment are based on the interdependence of resources; the actors need to cooperate with each other in order to access these

resources and achieve particular policy goals (Bruijn, de & ten Heuvelhof, 2000; Bortel, van, 2009). Interdependence among actors is induced by “the fragmentation of resources, such as funding, expertise, land and democratic legitimation, and links with local communities” (Bortel, van, 2016: 58). Interdependent relationships are “not necessarily based on equity, between public, private and civil society actors” (Klijn & Skelcher, 2007:587). Asymmetry in interdependent relationships should be taken into account in a policy network analysis. It should be recognized that not all actors have equal power; for example, not all of them are able to change rules or processes, to bear information, or hold financial resources.

Power, from a network perspective, is linked to the resources that an actor possesses. It can create asymmetry in relationships based on resource dependence, but it is not the only factor influencing the interactions in the network. An actor’s norms and meaning structures can also influence how the members of the network behave and cooperate (Klijn, 1997). Moreover, a network perspective assumes that relationships between organizations can affect the behavior of other individual actors (Bortel, van, 2009; Mullins & Rhodes, 2007). Ultimately, a governance network perspective analyzes “the relation patterns between actors, their interdependencies and the way these patterns and interdependencies influence the policy process” (Klijn, 1997:30).

It has been argued that “actors have their own definition of the world that surrounds them, which consists in their definition of the problem, their image of other actors in the policy network, the nature of their dependence upon others and vice versa, and the advantages and disadvantages of working together” (Termeer & Koppenjan, 1997:79). The characteristics of actors change according to their position in the network, taking into account an actor’s position as a public or a private organization. For example, the role of the housing company of the Municipality of Quito sometimes resembles that of a private developer when it acts as both a private and a public entity.

Diversity within networks warrants due consideration. As Ostrom (1990) sees it, the number of actors involved will not necessarily influence cooperation. However, this does not mean that the more actors, the better; it is advisable to include only those who are strictly necessary to the particular policy field. However, diversity means complexity, which has a bearing on attempts to influence or steer behavior of actors in a policy network. Multifirmity requires other skills than those used in traditional management settings; instead, it requires management at a distance, taking into account “the multifirmity of the network and the actors who operate within it” (Kickert et al., 1997:54).

The closed nature of networks can also present challenges to policy network management. The concept of closedness comes from systems theory; a closed network does not react to external input as more open ones will do. Thus, a closed network will process input in its own way, recognizing that complex social systems are self-regulating (Kickert et al., 1997:55). Given these characteristics, there is going to be uncertainty about whether the network or a group of actors within it react, or not, to steering signals from the network management. The advantage of closedness lies in the high levels of social capital. As Ostrom and policy network scholars note, closedness is an important characteristic, imbuing networks with a capacity for self-management which can be adjusted or steered using minimal coercion or resources.

§ 6.3 **Composition of the low-income condominium policy network**

Professionals in the external network are agents of condominium governance. They can be either individuals or organizations. Some were already mentioned in chapter 4, when analyzing the housing market and the subsidy policy for low-income homeownership. In both Colombia and Ecuador, the design and implementation of housing policy have changed from a hierarchical towards a horizontal structure, whereby the role of government has become somewhat dispersed. Participation of both public and private organizations is now needed to achieve national housing policy goals.

The analysis of the property law in both countries allowed us to identify which actors are directly mentioned in and regulated by the horizontal property law. Some of them are external to the condominium housing arrangements, while others are internal, having rights and obligations to govern and maintain the common property. These analyses, together with information from the semi-structured interviews, helped us to construct the list of actors in the policy network. In Table 6.1, the external actors for each city are listed and classified as public or private actors.

In general, the policy networks of Bogota and Quito have similar configurations. At least, they are composed of the same kind of actors: public actors like the ministry, municipal departments, the property registry, and public savings funds that also act as mortgage lenders. However, there is a public actor in Quito that does not exist as a public actor in Bogota: the public social manager. And among the private actors, there is one important actor in Bogota that does not exist in Quito: the property manager. Although there are property managers in the housing market in Quito, seldom does

one find an affordable housing project with a property manager. There is also another actor in Bogota, the Family Welfare Funds (*Cajas de Compensación*), which are the non-profit private entities through which government facilitates the subsidy policy. This role was already identified in chapter 4 as a difference between Bogota and Quito related to how the subsidy policy works in Bogota.

The comparison and the socio-legal analysis of the property law bring two actors into the foreground. Both are external to the policy network but their work is directly related to the internal governance of condominiums. These are the property managers and the social managers.

	BOGOTA	QUITO
Public		
	Ministry	Ministry
	Municipality	Municipality
	Cadaster	Cadaster
	Property registry	Property registry
	National Savings Fund (FNA)	Social security institute (IESS-BIESS)*
		Municipal housing company
		Social managers of ministry or municipal housing company
Private		
	Developers	Developers
	Lenders	Lenders
	Property managers	N/A***
	Notaries	Notaries
	Social managers	Social managers
	Family welfare funds**	N/A
	Insurance companies	N/A***
	Security companies	N/A***

TABLE 6.1 Actors involved in the policy network in Bogota and Quito

* It is also a public bank.

** In Spanish *cajas de compensación familiar*. More about these is explained in Chapter 4.

*** Not common in affordable condominium projects, but exist in the market.

§ 6.3.1 Social management (*gestión social*)

The research in both Bogota and Quito identified social managers that are involved in the governance of low-income condominiums. They are not regulated by the law, nor do they fall under policy regulations. Social managers can be private or public organizations, they may be working for the ministry, the municipality, or with the developer. Here the term ‘social manager’ is used to express their role in facilitating the process of community building, which entails a general understanding of the internal governance arrangements of the condominium.⁴³

Social managers are positions that have emerged in both cities. These actors assume facilitating and mediating roles in the provision of affordable housing and the enforcement of condominium regulations. It is not clear whether they pursue any sort of altruistic aims, such as trying to help low-income families, or have a professional relationship aligned with the developers’ goals. Either way, they strive to attain the more general goals of affordable housing policy.

The people working as social managers are social workers, social psychologists, sociologists, or economists. They have developed methodologies to facilitate interaction between professionals and homeowners during the transaction process. In practice, what they do is to assist with community building, particularly by identifying leaders that can support the construction of social capital.⁴⁴

During the focus group sessions and interviews, these actors expressed concern about how little the owners seem to know about the horizontal property regime. They agree with the property managers that the lack of knowledge and information on condominium governance and management can cause some nuisance, affecting the decision-making process that forms the basis for maintaining the property. Social managers in Bogota and Quito agree that their role in the network is unique. They are the only actors with enough training and the necessary social skills to transmit information and to help build social capital among residents as these co-owners take over the governance and management responsibilities.

43 In Bogota, people use terms like “gestión social” (social management); in Quito, “acompañamiento social” (social mentoring).

44 The social manager mentioned the social capital of the community as an indicator of the work they do. Bogota, Focus Group 2, November, 2012.

The role of the social manager is temporary, being confined to the first months while people are moving into the units. Not all affordable housing developers in Bogota, and certainly not all in Quito, hire social managers to help with the governance arrangements during the property exchange processes. Their participation and the work they do in both cities is informal and not regulated by any norm or law related to housing policy. Therefore, their participation is not compulsory; rather, their emergence is an outgrowth of governance arrangements.

To their mind, good indicators of successful work with the community would include (1) less conflict among residents, (2) a functioning board, and (3) less default on the agreed maintenance fee. One indication of success in Bogota is the presence of a property manager performing proper maintenance. In general these indicators are measured only a few weeks after these actors finish their workshops with the community. Developers in Bogota, notably two big housing development companies,⁴⁵ contract out property management or even have their own social management department on which leaders of the housing complexes can call for assistance. *Constructora Bolivar* of Colombia confers a Bolivar Award for condominiums in recognition of good performance to any of the low-income condominiums built by them. The award recognizes their success with internal organization and compliance regarding maintenance of the common property.⁴⁶ *Constructora Bolivar* also has a property manager's association, through which they can continue providing training skills for people that will participate in that capacity. This association also provides technical assistance for property managers. As the company explains it, this is part of their social contract with society, which is tied to building affordable housing. They ensure sustainability of finance and management, care for the environment, and engagement with the community. These kinds of strategies are inspired by the private sector and can lead to support in the long term for low-income condominiums; whereas these strategies are applied in Bogota, they are not followed by developers in Quito.

Considering the role and position of these actors, both in Bogota and Quito, some differences and similarities may be relevant to the performance of the governance of the condominium. In both cases, there are not many social managers; basically, social managers specialized in condominium issues are pioneers. In Bogota, which has a more liberal tradition, social managers are private entrepreneurs that work for the developer. In Quito, on the other hand, there is greater diversity among the actors

45 Like Amarillo and Constructora Bolivar

46 <http://premiobolivar.com/>

that play roles as social entrepreneurs. The few that have emerged in Quito in recent history have been private non-profits. Over the past two years, both the municipality and the ministry have established their own departments to perform the role of social managers. This highlights a difference in the approach when compared with Bogota's private-sector strategies. The incorporation of actors with social skills into policy teams suggests that the other actors are aware of a problem. It is also a sign that they believe the social manager's presence will influence how owners assume their role in the governance of the condominium.

The fact that in Quito social management is hired or incentivized by the public sector demonstrates a concern with the policy outcomes. The discourse about the role of social managers is couched in the language used by some Latin American scholars in housing research who argue for what is called the 'social construction of habitat'. That concept denotes a constructivist approach to housing, an approach widely pursued in Ecuador by actors that favor social housing policies.

In Colombia, in contrast, it is the developers that promote social management. In Bogota, these actors are also concerned with how communities manage and maintain their buildings. Even more importantly, they care about their success as developers and their reputation among low-income housing consumers. Since Bogota has more affordable housing developers than Quito, competition among them is stiffer in Bogota; therefore the actors in the housing development process try hard to win more clients for their projects.

The interview with a social entrepreneur in Bogota revealed the need to hold informational sessions with the project managers of the development companies (Graña and Amarilo):

[original version]

L: Entonces nos dimos cuenta de una cuestión bien importante y es que los técnicos, por naturaleza no son sociales, los técnicos son generadores de conflictos con el cliente, porque ellos son así.

R: Son los que generan conflicto?

L: Si, entonces nosotros dijimos entonces lo primero que hay que hacer es conciencia social en el personal técnico de obra para que entiendan, que lo que están haciendo es importante y que va a afectar la vida de seres

humanos. Entonces nosotros generamos todo un tema de capacitaciones, Graña inmediatamente se la creyó. Amarilo, lo hicimos hace poco, pero Graña inmediatamente dijo, esto hay que hacer con todo el equipo técnico, y lo hicieron con toda la empresa, dictarles unas conferencias, unas capacitaciones para que ellos entendieran, que era lo que hacia gestión social, y porque lo hacia y para que lo hacia. Desde ahí tenemos muchos hinchas en los mismos gerentes de proyecto. La ignorancia no es solo en nuestras comunidades, la ignorancia también es nuestra, las constructoras, del equipo que esta haciendo parte, los desarrolladores del proyecto

[translation]

L: So, we noticed a very important aspect, that is that technicians, by nature, are not social, technicians are conflict generators with the clients, because they are like that.

R: They are the ones that generate conflict?

L: Yes, then we said the first thing to do is create social consciousness within the technical workers involved in the building process so that they can understand that what they are doing is very important and that it will affect the life of human beings. Then we generated, a little while ago, a series of lectures, Graña immediately bought into the idea. Amarilo, we did it a while ago, but Graña immediately said, we need to do this with all the technical team, and they did with all the company, giving lectures, and training to make them understand what that social management does and why we do it. Since then we have many fans of the project managers. Ignorance is not only found in our communities, ignorance is also our own, the builder's, the team that is part of the project development.

Since the social management role is not regulated by policy norms, different strategies have been developed in Bogota and Quito. Each company can take a different approach to the work they do with the community of co-owners. Table 6.2 includes the list of social managers in Bogota and Quito and shows their relationship to the affordable housing projects that were studied. In Bogota, they are all part of the private sector, whereas in Quito they are both public and private.

In Bogota private initiatives include corporations, horizontal property training schools, and social movements such as the *Nodo de Propiedad Horizontal de Bogota*. Their

participation in the policy network is sometimes by invitation from developers and sometimes by way of their involvement in social housing movements.

In Quito, on the other hand, both the municipality and the ministry put social workers in charge of social management. Most of their interventions concern rules and manners for co-residence and the rights and obligations of co-owners. Whereas in Quito there is no formal course in which both owners and future leaders can receive training in governance and management in horizontal property, that opportunity does exist in Bogota.

SOCIAL MANAGER	BOGOTA	QUITO
Public	N/A	++
Private	+++	+++
Characteristics	Corporation, Independent training school, Developer's department.	Foundation, Women's association, Municipal department.
Contracted by	Developers	Developers, Public departments

TABLE 6.2 Social management organizations, Bogota and Quito. (author, based on fieldwork)

Some of these social managers have more than ten years of experience; this is true of the *Responder* corporation in Bogota and the *Bien Estar* foundation in Quito. They have each developed their own methods through the years, regularly evaluating their performance to improve the outcomes and their strategies. They both work on co-residence rules, help to identify leaders in the community, and then support decision-making to make the first internal regulations, the co-residence agreement, and help establish the first board of homeowners. They both engage with the communities step by step while sharing information about the rights and obligations, opportunities, and difficulties about living in horizontal property. Maintenance of the buildings is delegated to the property manager, while the expenses or costs need to be assumed by all in a cooperative manner.⁴⁷

47

In 2013 together with Fundación Bien Estar we organized a meeting in Quito where leaders of Fundación Responder, Fundación Bien Estar and Social Management of the Housing Ministry were able to discuss and share methods for and approaches to the work they do.

§ 6.3.2 Property Manager

Another key actor directly linked to the maintenance of the condominium is the property manager. In low-income condominiums, this role is not generally performed by a large management company. Instead, the association of homeowners employs an individual who earns a basic monthly salary; alternatively, this person can be hired by the developer during the phases of exchange of property. The property manager does not have a definite position as an actor in the external or internal networks. The laws of horizontal property are prescriptive in this sense; therefore, the final result is an outcome of the processes of governance and decision-making, whether at the external or internal level. The networks of Bogota and Quito differ quite significantly in this respect.

By law, in Bogota, having a property manager is obligatory. This actor should be hired by the developer during construction, and the developer should keep this employee on a provisional contract until the exchange of common property is finished.

The property manager then becomes an external actor that responds to the interests and goals of the developer. When the assembly of owners is constituted, owners can decide to hire a new property manager, which by law becomes the representative of the legal entity of the condominium. The property manager is an actor in the internal network, and as such he/she can respond to the interests of the homeowners when problems arise with the developer. As a property manager who participated in the focus group in Bogota expressed:

"There is something that we have not been taking into account in this discussion, let's say during production, well, it is time to 'give a stick' to [put pressure on] the developers ("*dar palo al constructor*") so that they can take this into account and look for solutions, because at the end of the day, when problems of deterioration caused by bad construction or bad materials occur, they are the ones that have to respond. Some problems are only evident when people use the dwelling. So there are problems with the guarantee: with the request process and compliance as the responsibility of the developer."⁴⁸

In Quito, on the other hand, a provisional property manager is not compulsory. By law, however, the board of homeowners, acting upon the assembly's decision, can hire an external property manager or, if they cannot afford one, can delegate management responsibilities to the president of the assembly of homeowners. Accordingly, the position of the property manager falls under the governance arrangements between co-owners and the developer.

The position of the property manager, whether internal or external, will influence the perspective of other actors involved in the network as well. Moreover, it will influence the maintenance of the common property. Some property managers do not want to work with low-income condominiums because they know that people cannot afford the expense, or because there is no board of homeowners capable of enacting the formal procedures to hire them.⁴⁹ As expressed by the same property manager in the focus group in Bogota:

"There is another aspect of the problems that the owners and residents have, which is about the profiling of the customers, so that somebody has to see that the monthly mortgage payment, plus the maintenance fee has an approximate value of x is something that they can afford. And even though by the laws of consumers the builder's sales office has to be transparent about these costs."⁵⁰

The property manager is an actor that stands between the owners' interests and the developer's position. In the course of their job, property managers are directly affected by affordability problems and the lack of information about the property regime. Property managers in Bogota organize different activities to raise funds in other, more creative ways. They may hold parties or raffles to collect money to cover, for example, the costs of improving or renovating floors or the tiles in common areas.

In Colombia, even though the law requires a property manager, some low-income condominiums cannot afford one. The obligatory role of the property manager has been an incentive to create learning centers where individuals can train and become

49 Conversations with property managers of low-income condominiums in Bogota, June, 2011, September

50 Horizontal property manager of a low-income condominium. Focus group 3, Bogota, November, 2012 [recording min.1:12'10"]

professionals in condominium property management. In Ecuador, in contrast, property management by an external actor is not obligatory. The president of the board can assume that role as an internal actor if the condominium has established a board of homeowners and kept it running through the years.

§ 6.4 Characteristics of the policy network

Using information from semi-structured interviews and focus groups, this section compares three characteristics of the network: multiformity, interdependence, and closedness.

§ 6.4.1 Multiformity

Multiformity, in the network perspective, lies inside an organization, guiding its core values and goals (Kickert et al., 1997). The present research has identified several differences in values and goals between Bogota and Quito. In terms of goals, the actors from Bogota and Quito that have corresponding roles, it is interesting to observe some differences between their values; those differences have actually influenced the behavior and therefore the characteristics of the network.

Values

Actors' values comprise one of the dimensions that can illustrate the multiformity of a network. Different values make the network characteristics more complex, and if differences do not complement each other they can lead to conflict. Differences in values are evident from the actors' lines of reasoning, which influence how they perceive other actors' behavior in the network. For example, a complex relationship in which values diverge sometimes grows between the developer and the property registry officer, as seen in both Bogota and Quito. Ultimately, the role of the property registry is to guarantee that the formal processes related to the ownership regime and housing policy are carried out correctly and that the outcomes are recorded in the title deed in compliance with established rules. Interviews showed the importance of honesty and accuracy for a robust property registry, yet these may conflict with the values of

some developers who prefer efficiency and, for the sake of expediency, might register condominiums with documents that include mistakes.⁵¹

As one official from the property registry in Bogota put it:

"...to definitely receive the subsidy is when they [developers] come through my office. If the title is not registered, even though the subsidy has been approved, and even though the title is written and complies with general requisites, with the savings and all that is ok, but if it doesn't comply with the legal requisites they don't give the subsidy, until they receive my signature. And then they can get the 'certificate of freedom for property transactions' [*certificado de libertad y tradicion*'] stating that they [dwellings] comply with all requisites of the law of social interest housing or housing of priority interest."⁵²

The perception of the developers regarding the position of the property registry is generally ambivalent. The property registry has the power to stop the process until all documents are correct, referring to documents of the individual purchaser and those of the condominium. The differences in values influence another network characteristic, namely closedness, as expressed in the veto power of the property registry office, which will be discussed further in a following section. Developers need to carefully consider this phase in their project management in order to ensure their expected outcomes. They need to stick to values such as accuracy, responsibility, and honesty regarding the technical work they perform.

In other cases, the values may differ but cooperation may still be possible. In Bogota values such as social responsibility in the work they perform made some developers absorb the costs of hiring social managers to facilitate community building. At the same time, that action facilitated the closing of sales, which in turn is good for the developers' main goal. Social responsibility was one of the values mentioned in Bogota, along with the quality of housing provided for all of the income groups they serve.

51 Interviews with stakeholders of property registry offices, in both Bogota and Quito, mentioned difficulties with developers regarding compliance. When specific information about the properties is not correct, the process is delayed until the developer can re-submit the documentation for further registration. Of course, not all developers make mistakes.

52 Property Registrar, Focus group 4, Bogota, November, 2013.

Competition with other affordable housing developers makes the developers value the quality of the housing complexes; that is unlike the situation in Quito, where the developers did not mention quality.

In Quito, the values of the developers, such as their technical responsibility in the provision process and their conviction of the need to provide affordable housing, kept them in the network. They stayed in that network, even though it was difficult to continue operating in that market. The reason for this difficulty was the lack of trust in the subsidy housing program. This is another value that developers in Quito hold dear; they want stability and continuation of the subsidy policy in order to plan their investments and housing developments. However, developers have lost faith in the housing program due to the changes that are made to its policy mechanisms every time there is a new official in charge at the housing ministry.

Goals

Looking at the public and private actors in both networks, one discerns common ground in their goals. Table 6.3 presents a list of actors and their goals, as derived from their remarks during the semi-structured interviews, when asked about their role in the network and their main goal as an organization. Let us start with a comparison of the roles and goals of the housing ministry in both countries. Colombia's goal of raising the number of homeowners is more clearly articulated than that of Ecuador. In the Ecuadorian national plan, the goal of achieving adequate housing for all is stated from a human rights perspective. Therefore, if Colombia's focus is on subsidy policy, its goal is to allocate as much money as possible to building for owner-occupancy. The goal of allocating a certain number of subsidies for low-income homeownership is difficult to achieve in both cities. A subsidy is not considered 'allocated' until the owner has completed the purchase process and has received the unit from the housing developer or from the organization in charge of selling the units.

When looking at the diversity of organizations and actors involved, it appears that each one has different goals; while one wants to allocate and close mortgages, others want well managed communities. The situation is similar in Bogota and Quito. Despite their differences, the networks of Bogota and Quito produce affordable housing. The organizations have been working together for more than two decades, so they know how to manage their differences. For example, because Ecuadorian developers do not have much faith in the subsidy policy, they become very active as soon as policies seem about to change. They get involved in the policy process to ensure that the subsidy policy remains in force, ensuring a strategy to achieve adequate housing.

Even though organizations have different values, they are prone to collaborate due to other factors such as interdependence. As for Ecuadorian developers, they depend on the housing ministry to keep their business going; otherwise, dwellings would not be so affordable to low- and middle-income families.

BOGOTA	ORGANIZATION GOALS	QUITO	ORGANIZATION GOALS
Public			
Ministry	More homeowners	Ministry	Subsidy allocation for homeownership
Municipality	Achieve provision of affordable housing in the city	Municipality	Achieve provision for affordable housing in the city
Cadaster	Updated information of land and properties	Cadaster	Updated information of land and properties
Property registry	Record correct information in titles	Property registry	Record correct information in titles
National Savings Fund (FNA)	Good savings and percentage of mortgages financially closed	Social security institute (IESS-BIESS)	Issue mortgages financially closed
N/A		Municipal housing company	Produced and sold percentage of affordable dwellings
N/A		Social managers of ministry or municipal housing company	Sustainable communities
Private			
Developers	Dwelling sales, profit	Developers	Sold dwellings, profit
Lenders	No defaults mortgages, percentage of closed ones	Lenders	No defaults mortgages, percentage of closed ones
Property managers	Earnings based on co-owners' maintenance fee payment culture	N/A	
Notaries	Earnings due to high number of sold dwellings	Notaries	Earnings due to high number of sold dwellings
Social managers	Well-managed communities	Social managers	Well-managed communities
Family welfare funds	Subsidy allocation	N/A	
Insurance companies	Building insurances	Insurance companies	
Security companies	Contracts with co-owners	Security companies	

TABLE 6.3 Actors' goals in policy network in Bogota and Quito

§ 6.4.2 Interdependence

Interdependence is an important factor. It shows the relative position of each actor in the network, considering the resources they use to achieve their goals. The distribution of resources across all of the players demonstrates the level of interdependence among them, especially when one actor needs the resource that another actor possesses or manages. For instance, the provision of housing is contingent upon the allocation of subsidies in the form of a down payment for low-income housing. That is a subsidy given by the government through different organizations in Bogota and by the ministry itself in Quito. The provision process is also highly dependent on municipalities' norms and regulations for land and housing development, particularly on their capacity to provide cheap land with basic services, in order to develop housing for the poor.

A strong dependence on the municipality's norms and regulations emerged as the main resource dependence that everyone in the focus groups mentioned.⁵³ Strong dependence was also mentioned with regard to the availability of cheap, developed land. For instance, one participant in Bogota framed dependence in this way:

"First you need land; otherwise you cannot give titles of units that are built in the air."⁵⁴

Table 6.4 names the actors and the main resources they use to achieve their goal. The chart only includes data that was collected during the focus groups. Therefore, an abbreviation in the table denotes 'not present' (np) for the actors did not in attendance at the focus groups held in Bogota. The fact that actors such as the ministry and cadaster did not attend the meeting is most likely a sign that they do not see a role for themselves in the network. Apparently they did not have any interest in participating with the other actors in the network.

53 During the focus groups, the participants were asked to assume that subsidies and land are a resource that in fact exists, an assumption that was posited to avoid never-ending discussions about the presence or absence of these two key resources for housing policy. The important question concerns who has these resources and what their relationships are with other actors.

54 Focus group, table 1, Quito, October, 2013.

BOGOTA	ORGANIZATION RESOURCES	QUITO	ORGANIZATION RESOURCES
Public			
Ministry	N/P*	Ministry	Subsidies as affordable housing incentives
Municipality (several departments)	Land management, subsidies, human resources, norms, design, projects, urban planning, different forms of associations	Municipality	Planning and license departments, norms and management, procedure norms, ordinances.
Metrovivienda	Land management and development	Public housing company	Municipal norms, private finance, housing program, land, technical human resources, municipal budget, management capacity
Cadaster	N/P	Cadaster	Information, ordinances for property registry and appraisal
Property registry	Laws, subsidy policy, horizontal property law	Property registry	Horizontal property law, domain historical data, tools to guarantee legality of property transactions
National Savings Fund**	Savings, subsidies, developers with green stamp, land	Social security institute	Annual budget for investment, Mortgages
		Social managers	Condominium communities
Private			
Developers	Materials, building capacity, economic resources, subsidies, loans, knowledge, information	Developers	Private finance, technical knowledge, human resource, national subsidies, social accompaniment, efficient housing construction, experience
Lenders	N/P	Lenders	Knowledge and experience in housing finance and development, support for affordable housing developments, loans for builders and buyers
Property managers	Management, training, normas, owners, maintenance fees, training and education capacity	Property managers	N/A
Notaries	N/P	Notaries	Norms, and instruments for titling
Social managers	Community, horizontal property law	Social managers	Comprehensive product for community management
Family welfare funds	Subsidies, housing policy, housing supply	N/A	

TABLE 6.4 Actors' resources in policy network in Bogota and Quito

Source: Focus group, activity 1

* Not present in focus group.

** Public lending (FNA).

The other key resource that makes two actors interdependent is financing, both for the future low-income owner and for the developer. As one actor in Bogota put it, no matter what they do, the process of provision only goes part of the way toward satisfying their needs if other actors in the network do not collaborate with them:

"There are units for which we cannot finish the sales process because it is not possible to do a financial closing or because the subsidy is delayed, the financial entities also delay the transfer of money or because the municipal services departments do not give the certificate of utilities availability, so all this is an indicator. We can produce, but if the other entities do not support the process of sales then we are stuck halfway, with the costs of the effort."⁵⁵

The goal of the subsidy is to ensure that the amount, together with a small sum in savings and a small loan, will be enough for the beneficiary to afford a low-cost dwelling. Affordability problems among low-income people can kick in at this point in the process and would therefore affect the network as a whole. This linkage illustrates the interdependence that arises among future owners and the lending organization, the notary, and the property registry, a relationship that ultimately affects cooperation among all actors in the policy network and how they achieve their interests.

The actors that mentioned experiencing direct interdependence with low-income owners were the property managers and the social managers. They referred to low-income owners as 'beneficiaries', 'the community', or 'the owners'. The actors in these two management positions saw the owners as a kind of general resource for achieving their goals, implying that they perceived owners as a collective and not as individual households.

The position of the ministry in the network resembles its position in the vertical structure of government. That may be inferred from how strongly the external actors in Quito perceived their relationship with the ministry, a relationship based on the subsidy resources that the government provides. This interdependence is not asynchronous, because the relationship during implementation of policy is not temporary. The ministry, the developer, the municipality, and the owners will be

engaged in the process for several years, at least until all the dwellings have been built and sold. The situation is different in Bogota. The Colombian ministry has less presence in the network than it does in Quito. The institutional design of the policy and the role of the Family Welfare Fund make the network of Bogota more horizontal than that of Quito regarding the role of the housing ministry.

Looking more closely at interdependencies, it appears that some actors think the interdependence with regulations and norms and the registration of condominium properties is complex. Norms and regulations refer principally to (1) the housing law that regulates the subsidy allocation process, (2) city spatial plans, (3) building codes, and (4) horizontal property law. Actors in the focus groups perceived the regulations as complex because they tend to change according to political conditions.⁵⁶ From a network perspective, a lack of stable regulations can lead to problems when the effect of regulations is to establish unstable arenas and patterns of interaction, thereby affecting the outcomes of the governance network. Those actors that establish and manage processes related to normative and regulatory resources have a very strong position in the network. These strong actors are the ministry, the municipality (building permit department, cadaster), and the property registry.

Actors such as the building permit department, the cadaster, and the property registry have a difficult role. They have to make sure that every project and every dwelling is in compliance with the legal procedures of securing homeownership.⁵⁷ These processes generally take time and are often referred to by the developers as the most critical moments in the development of housing. Successful interaction with these three departments will mean that negotiation with lenders (mortgage money transferred) and with the ministry (subsidy) will allow the financial process to be completed.

The research for this thesis revealed an interdependence between these departments and the social manager. That interdependence is perceived as strong because the actors can serve as mediators; they recognize problems and difficulties in governance or even delays in housing provision. In Quito, the municipal housing department, which

56 In practice, it is only the city's spatial plans and the housing law that change frequently, as these are susceptible to planning processes and political decisions. The housing law that regulates the subsidy is perceived as changeable because it is contingent on national goals, development plans, and spatial plans, all of which tend to change according to local political dynamics. Changes in policy norms create changes at the procedural level, thereby complicating the provision process; actors then need some time to adapt to new institutional changes.

57 The municipality of Bogota has a department in charge of the control of housing developers to avoid fraud for consumers. Developers need to register the project information with this department in order to get authorization to sell housing units. In Quito, there is no department that resembles this role.

acts as a public developer in the network, has a team of social workers. In September 2012, the ministry of housing (MIDUVI) installed a new department with the task of managing the social process for community organization. Some private developers have also incorporated the collaboration with social managers into the provision process.⁵⁸ The position of this actor in Quito is not yet clear in terms of the network described in the previous sections.

The role of the social manager in Bogota is accompanied by the role of the provisional property manager, as required of the developer by the property law. According to the law on horizontal property, the developer is obliged to employ a provisional property manager until 51% of the units have been sold. At that point, the law requires the developer to organize the first assembly meeting in order to transfer the powers of governance and maintenance of the property to the new community. Interdependence with the developer throughout this process is critical because, until all sales are finished, the developer is also a co-owner in the condominium. While still trying to finish up the sales, the developer will be concerned about maintenance. In that light, the developer may turn to marketing strategies that are generally used to attract buyers and create an environment of confidence with an eye to future projects.

This is the period of time in which interdependence between owners and developer is vulnerable to conflicts. The presence of the developer inside the ownership regime creates the perfect environment for a free-rider culture among new owners. That is because the developer is still covering most of maintenance costs and responsibilities. Meanwhile, the developer is not sharing information or the power of decision-making with the new owners.⁵⁹ The interdependence established by the developer as owner is a disincentive for advancing the self-government process. The interaction changes when the social manager is present because owners then have direct access to an actor who can mediate on interdependence issues with the developer. Even though in Bogota a property manager is required by law, few developers have incorporated the assistance of social managers until the community is ready to take responsibility. Some developers, in both Bogota and Quito, prefer to engage teams with social expertise in condominium organization to facilitate successful financial and social conditions for closing of the project. So doing would ensure their return on investment and complete

58 Municipal Public Housing Corporation (Empresa Publica Metropolitana de Vivienda), interview and visit to Ciudad Bicentenario housing development with Alexandra Jaramillo, Quito, Sept, 2012. Mutualista Pichincha housing development, and Bien Estar Foundation. MIDUVI, new department of 'gestion social' (social management).

59 While the developer finishes the sales process, post-sales problems with the construction of the property start to appear, and the developer is responsible for fixing those problems.

the project on time, as planned. The social managers, being hired by the developer, are in a difficult position both inside and outside the condominium governance levels. They depend on the developer's resources as well as on the owners' participation for the work they do.⁶⁰ Consider, for example, what is still going on in *Ciudad Verde*, the urban development project from which one of the condominiums for the survey was chosen. There, the private developer is still in charge of the maintenance of some areas. So the developer hired a social management corporation to help maintain the organization of the many housing blocks that are built. In the end these costs accrue to the developer.

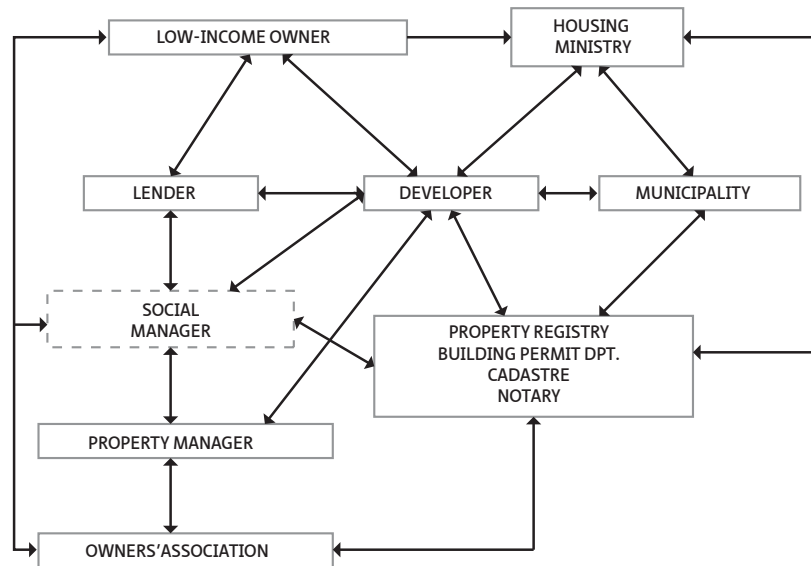


FIGURE 6.1 Actors and interdependency (source: Focus groups results, empirical research, 2012)

Figure 6.1 is a diagram of the interdependent relationships among all of the actors who participated in the focus groups in both cities.⁶¹ At the top are the two main actors in housing policy: the end-beneficiary of the subsidy; and the low-income owners,

60 Their work involves a series of workshops and activities with owners as informative meetings but also community building. During these workshops, social entrepreneurs identify leaders in the community that can assume roles on the board of homeowners.

61 Social managers appear in a dotted box because their presence is exceptional; only a few social entrepreneurs were found. Considering the system as a whole, the norm is that there is no social entrepreneur.

who are directly connected to the policies of the housing ministry since they form the target group. The developer, the municipality, and the lender appear at the second level; they are related to the actors above and below them. Other actors such as the social manager and the property manager are critical to the relationship with the lender and developers. Finally, the owner's association is the collective actor that closes the circle of interdependent relationships in this network. Once it has been constituted, the association finishes the development phase and takes over the governance and management responsibilities. The position of the social manager is different and its box is therefore drawn with dotted lines suggesting porous boundaries. Although he/she is the only actor that is not regulated by the law, the social manager is nevertheless part of the policy network.

§ 6.4.3 Closedness

Actors in this policy network of affordable housing under a condominium regime respond to certain steering policies, especially the ministry's rules for subsidy allocation. When they do not respond to steering policies, or other interventions, it can be said that the actor demonstrates a closedness characteristic within the network (De Bruijn & Ten Heuvelhof, 2012).

However, the process for developing housing in coordination with a set of actors that will use the subsidy is not specified in detail and is thus left to governance dynamics. In this context, from a network perspective, some actors will be less responsive to steering policies than others. Also, some actors have veto power within the network, meaning that their level of autonomy allows them to choose whether or not to participate in policy the network, or even to stop the process until there is compliance with their own rules.

Differences in how actors respond to steering policies reflect each actor's frame of reference, which is built on the core values of its organization. Some closedness to the steering signals of policy is necessary. In the dynamic political context of Colombia and Ecuador, in which national policies for subsidy allocation adhere to political trends, some level of closedness is beneficial, as it ensures continuity in the provision of housing thanks to the autonomy of certain players.

Closedness as expressed by the property registry, that was also perceived by the developer on the part of the registry is also necessary to some extent. If the dwellings are to be owned, the property registrar will be a key actor, ensuring the legality of the process and assuring that the documentation is complete.

It is relevant to point out some closedness characteristics of the developer. These vary, depending on whether the developer is a private enterprise or whether it is the municipality acting in that capacity. The developer's position is strong, but also vulnerable. If developers' financial interests are not assured, they will not enter the policy network, putting the ministry in a difficult position with respect to achieving policy goals.

Closedness on the part of the developer can provoke conflict. Once the property rights have already been established as collective ownership, the owners can become more active and exercise their self-governance powers. However, this is not convenient for the developer until the project is completely finished. Closedness of the developer is mediated by the temporary property manager or by the social manager, if there is one. In cases where there is neither a property manager nor a social manager, some owners have taken on leadership roles. Based on their recently acquired property rights, they can mediate with the developer to make the co-owners' voice heard.

§ 6.4.4 Conclusion about characteristics of the network

Network characteristics such as multiformity (of goals and values), interdependence, and closedness give information about the behavior of actors and their positions in a process that requires collaboration in order to achieve the goals of each one. In this analysis, the property manager and the social manager stand out as those actors that had contacts with families in both cities. Other actors, such as the municipal departments and developers reaffirmed their interdependent role, demonstrating that they are part of a network.

Actors from both cities mentioned that during the policy implementation process they relied on stable municipal rules for housing development and that finance actors were crucial to achieving their goals. In this regard, there were no differences between the networks of Bogota and Quito.

A difference was found between the cities regarding the role of the cadaster. In Bogota, this actor did not attend the focus group sessions, implying a lack of interest in getting to know or in participating with other actors in the network. The opposite occurred in Quito, where the role of the cadaster is critical to housing development.

In summary, the system of housing policy implementation in both Bogota and Quito can be described and analyzed in terms of network theory since it is clearly

not a hierarchical structure anymore. In general, the actors acknowledge the need to collaborate, since they see their own position in terms of interdependent relationships.

§ 6.5 Perception of maintenance problems

The second activity during the focus groups sessions in Bogota and Quito included discussion of a vignette. The participants were presented with the scenario of an affordable housing complex, built by a private developer, which starts to deteriorate as soon as people move in. The same hypothetical case was used in both cities. It was presented in Spanish, so the version below is the translation.

VIGNETTE

Hypothetical case presented (with pictures):

A housing developer is ready to build an affordable housing project. After two years the dwellings are built and about 120 families will start moving into the housing complex. These dwellings are in a closed housing complex arrangement, and families are now supposed to take responsibility for maintenance of the complex. One owner will say, "I didn't know I have to pay this fee, no one told me, I already pay the bank."

Two more years pass and the housing development project starts to show signs of a lack of maintenance and deterioration. Some parts of the common property need finishing and the community is not doing much to change that.

Participants of the focus groups were asked two broad questions:

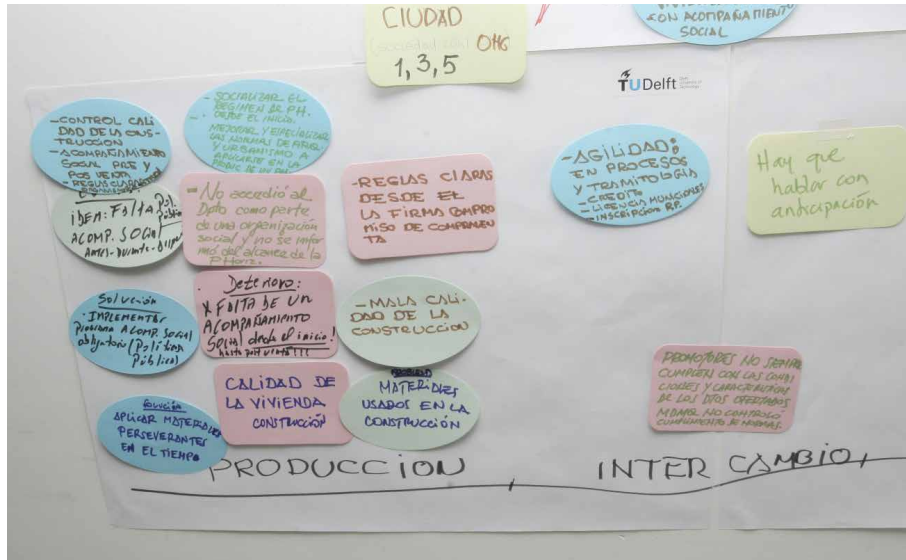
- 1 What went wrong, what causes deterioration?; and
- 2 What can be done to solve the problem?

The methodology called for active participation. This entailed writing ideas on cards and then placing these on a flip-over board. Participants were asked to draw a line on the paper-board to represent the timeline of housing provision, dividing it into the three phases of production, transaction, and consumption (see picture). The timeline of housing provision was used to guide actors to think of responses and situations that occur in each phase. Each focus group had a paper-board to work on and to affix the cards on which they responded to the questions regarding the case presented in the vignette (see chapter 3 for more detail).

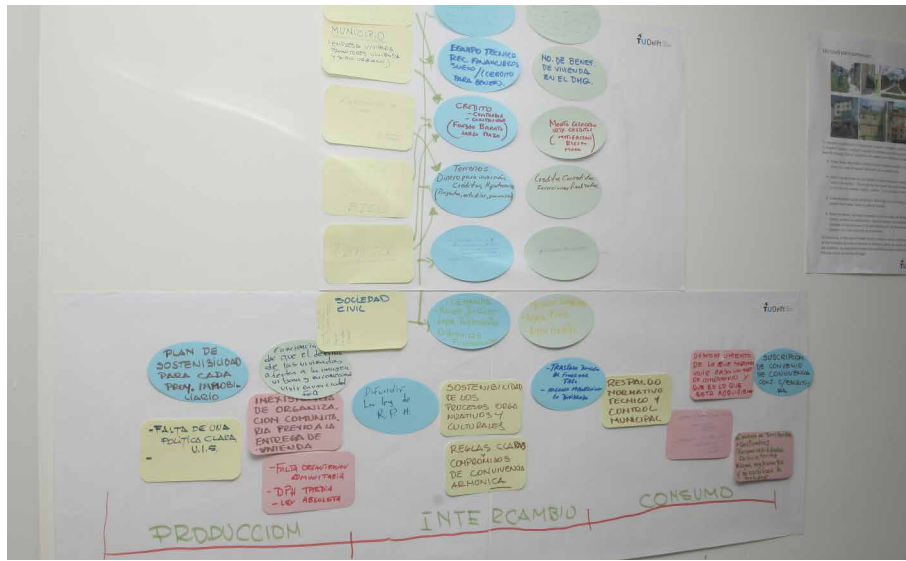
The responses reveal how the actors perceived the deterioration path presented in the vignette. The following sections analyze the responses in relation to each of the three phases of housing provision and draw comparisons between the perceptions in Bogota and Quito.



1



2



3

FIGURE 6.2 Focus group – Quito (Photo credit: R.E.Donos)

§ 6.5.1 Perceptions of problems in Bogota and Quito

Perceptions within the policy network in Bogota suggest that most of the problems during the production phase are related to inadequate coverage of the housing policy. As one of the actors wrote: *"The problem appears during consumption but the origin could have been the design or management that did not take into account the social aspect. All because of failures in policy design."* Table 6.5 below summarizes the responses related to the production phase. In Bogota, a problem that was mentioned in all focus groups was the misinterpretation of the economic capacity of the buyers. The estimates did not take maintenance costs into account. That comment led to a discussion of problems related to the design and the poor materials used in housing construction.

PROBLEM IDENTIFIED IN PRODUCTION PHASE	RECURRENCE OF RESPONSE IN FOCUS GROUP
Maintenance costs not considered in economic capacity of buyers	+++++
Design of dwellings, lack of finishes, poor materials	++++
Social configuration of communities	+++
Lack of coordination	++
Insufficient information given to buyers	+

TABLE 6.5 Bogota - problems identified in production phase

PROBLEM IDENTIFIED IN PRODUCTION PHASE	RECURRENCE OF RESPONSE IN FOCUS GROUP
Bad quality of construction and building standards	+++
Incomplete information about horizontal property	+++
Delays with construction process	+
Lack of community organization before moving in	+

TABLE 6.6 Quito - problems identified in production phase

In Quito, three of the focus groups mentioned the bad quality of construction and the building standards as the origins of the deterioration process, thus tracing its origin back to the production phase of housing provision. On this topic their perceptions correspond to those of their counterparts in Bogota, where bad quality of standardized construction and poor materials were mentioned as part of the cause of deterioration. Another perceived problem in Quito which was recurrently mentioned in the focus

groups is the lack of complete information about the horizontal property law. The future homeowners or beneficiaries of the housing policy are insufficiently informed. In Quito the law of horizontal property was mentioned from the very beginning as an important resource during the production phase. Table 6.6 shows which types of problems were identified and the degree to which each response recurred in the focus groups.

PROBLEM IDENTIFIED IN EXCHANGE PHASE	RECURRENCE OF RESPONSE IN FOCUS GROUP
Lack of information about maintenance costs	+++
Lack of social management in the process	++
Lack of information about property law	++

TABLE 6.7 Bogota - problems identified in exchange phase

PROBLEM IDENTIFIED IN EXCHANGE PHASE	RECURRENCE OF RESPONSE IN FOCUS GROUP
Internal regulations were not written with the community, lack of community organization	+++++
Lack of information about the law, rights and obligations	+++
Developers' lack of compliance with offered quality of buildings	++
Complexity with horizontal property law regulations	++
Delays in exchange processes	+
Buyers do not like the condominium regime	+
Poor construction quality	+

TABLE 6.8 Quito - problems identified in exchange phase

Other problems were identified that occurred during the exchange and consumption phases of housing provision. Regarding the exchange phase, the participants in Bogota identified a 'lack of information' about property law and maintenance costs as problematic factors that influence deterioration processes, as shown in Table 6.7. It is interesting that unlike the actors in Quito, who mentioned a lack of information about the law during the production phase, the actors in Bogota raised a more specific point regarding the exchange phase, namely the need to explain the legal obligations in detail. The necessary knowledge about maintenance costs can include the specific costs involved in certain complexes. Since not all affordable housing complexes are the same, each will require tailor-made planning and management for maintenance.

In Quito, the number of problems identified regarding the exchange phase was considerable. Again, the lack of information about the owner's rights and obligations was mentioned. However, it was very interesting that the actors mentioned one of the formal rules in condominium, namely internal regulation. They were concerned about the lack of participation of the owners in this phase, which they saw as problematic or even as a cause of deterioration. Other problems identified during the focus groups in Quito are related to the formal procedures for development, notably the need to register a horizontal property project in the cadaster and in the property registry before sales can start. Table 6.8 shows the problems perceived to have originated during the exchange phase.

Tables 6.9 and 6.10 list the more recurrent comments regarding problems that caused deterioration and are related to the consumption phase of the hypothetical case. In Bogota, actors mentioned the high level of household mobility, tying it to occupancy by tenants who do not have sense of ownership, as something problematic and related to deterioration. Renters were considered problematic by actors in that focus group; however, this comment appears only in this one table as it did not come up in the other phases. The same applies to the concern about the builder's construction guarantee, which the owners find difficult to use when materials or construction problems show up in the building. The actor mentioned that this problem was evident from experience. Even though it was not a recurrent comment in other focus groups, it is interesting to take note of the responsibility of an external actor (builder) for an internal governance problem.

The importance of management practice and economic resources for maintenance were the most recurrent comments regarding the consumption phase. The first comment, on management, expresses the perception that property managers can be either external or internal to the community. In Bogota, this role is obligatory and it is a paid job. However this comment may be related to a lack of economic resources for maintenance, which was also a recurrent comment in Bogota.

In Quito, problems causing deterioration were attributed to weak community organization and a lack of leadership. Another cause was perceived as the culture of individual living, implying different habits than collective ones, which can be related to the lack of respect for collective norms, rights, and obligations in condominium. Other comments were less recurrent: problems with economic capacity; the quality of construction, which includes materials that are difficult to maintain; and even informality, as when a co-owner pursues renovation or makes extensions in the building without due process (approval in assembly of owners).

PROBLEM IDENTIFIED IN CONSUMPTION PHASE	RECURRENCE OF RESPONSE IN FOCUS GROUP
Bad management	+++++
Insufficient economic resources for maintenance	+++
Lack of appropriation of common property as owners	++
Insufficient information	++
Failure with builder's guarantees	+
Renters do not have sense of ownership	+
Lack of social cohesion among co-owners	+

TABLE 6.9 Bogota - problems identified in consumption phase

PROBLEM IDENTIFIED IN CONSUMPTION PHASE	RECURRENCE OF RESPONSE IN FOCUS GROUP
Weak community organization, lack of leadership	+++
Lack of respect for norms, rights and obligations	+++
Cultural background of individual living, different habits	+++
Insufficient responsibility of condominium owners	++
Lack of maintenance, defaults on maintenance fee	++
Law is not adjusted to reality	++
Lack of maintenance by the property manager	+
Insufficient economic capacity	+
Building materials, environment more difficult to maintain	+
Lack of municipal control	+
Changes to building, informality	+

TABLE 6.10 Quito - problems identified in consumption phase

§ 6.5.2 Solutions

The focus groups also considered possible solutions for deterioration in low-income condominiums. As with the questions discussed above, the participants were asked to write up proposed solutions on cards and place them on the housing provision timeline that had already been drawn on the flip-over board mounted on the wall. Tables 6.11 and 6.12 summarize the solutions that participants brought up in the discussion, both in Bogota and Quito.

PRODUCTION		EXCHANGE		CONSUMPTION	
Planning for sustainability, all phases; self-sustainable communities	+++	Training with contracts, co-residents, common property, ownership	+++	Establish income-generating units inside condominiums to finance maintenance	+++
	++	Social and juridical information	++	Lower taxes	+
Different forms of ownership, organization and governance, "Juntas de acción comunal"	++	Established methodology to work with communities, maintenance fees	++	Use common areas to generate income	+
Education and training	+	Sensitize co-owners about the risk of de-valorization of their property	+		
Public policy to regulate social managers	+				
Involvement of all actors with future co-owners	+				
Include maintenance in financial assessments	+				
Maintenance of social interest housing projects to municipality	+				
Transparent information	+				

TABLE 6.11 Proposed solutions in Bogota

In Bogota three key solutions emerged, once for each provision phase. The participants came up with more solutions for the production phase than for the other provision phases. The most recurrent one is to plan for self-sustaining communities, a solution that could influence the outcomes of other phases too. The second most frequently mentioned solution is to think in terms of other forms of organization and of tenure when designing housing policies.

One of the solutions for the exchange process concerns training or preparation to become an owner. Specifically, training regarding the purchase contract would prepare the owners for co-residence, common property maintenance, and ownership by informing them about the rules. In regard to the consumption phase, actors in Bogota considered that affordable condominiums could include units or spaces that might be used to generate income to finance maintenance.

The list of suggested solutions for the production phase in Bogota can be useful when looking for ways to improve policy. Provision of full information and training was also considered important, and not only during the exchange process. Other forms of organization and ownership that would imply a change in the institutions of governance were also mentioned. For instance, attention was drawn to *Juntas de Accion*

Comunal, which are governance structures that have traditionally shaped the way low-income barrios are organized.

From a financial point of view, one solution would be to include maintenance costs in the financial assessment for a mortgage. That expense is apparently ignored in the economic analysis of the capacity to repay a mortgage, with the result that people cannot afford to pay any other costs, such as the monthly maintenance fee.

Working with the community and training the owners were mentioned as solutions. Furthermore, the actors recognize the importance of a single methodology for working with communities and determining how they can deal with maintenance costs. Many organizations already exist in Bogota to facilitate community self-organization. As they see it, there is every reason to seek common ground for intervening with communities, evaluating previous work, and improving methods of intervention.

PRODUCTION		EXCHANGE		CONSUMPTION			
Quality control of construction and materials	++++	Information about urbanization and building codes, law of horizontal property	+++	Establish internal norms and regulations according to social group	+		
Establish a financial equilibrium point before starting a new project	+	Training of community work	+	Practice "good living" concept	+		
Initiate and implement obligatory social management	++	Agreements with different institutions to expedite sales and transaction process	+	Maintenance with community work (minga)	+		
Disseminate information on the law of horizontal property	+	Include maintenance fees in mortgage financial assessments	+	Sign co-residence agreement when signing property title	+		
		Establish loans for condominium maintenance		+		Create a co-residence manual	+
		Establish minimum standards of building quality					

TABLE 6.12 Proposed solutions in Quito

Among the solutions proposed by the focus groups in Quito, two in particular stand out. Regarding the production phase, there is a need to improve quality control for construction and materials in affordable housing projects. Regarding the exchange phase, it could be useful to share information about building codes, and the law of horizontal property with future low-income owners.

There are more solutions of interest in Table 6.12. Regarding the production phase, two focus groups mentioned the possibility of making a social manager compulsory

as a means to prevent dwellings from deteriorating. And information on the law of horizontal property could be disseminated in the social management process.

Several solutions were mentioned for the exchange phase. One is to include maintenance fees in the financial assessment of the owner's capacity to repay the mortgage. Another is the possibility to establish loans for condominium maintenance. Regarding the construction process, one solution is to reach agreements with other institutions make the sales and transaction processes more efficient.

Ways to prevent deterioration during the consumption phase include community work, such as self-organization and informal activities. Other solutions belong to the realm of formal institutions, such as a co-residence manual, or the need to include a signature, as a contract, attesting that one agrees to comply with the co-residence rules, when the owner signs the property title.

In Bogota, the focus groups mentioned that deterioration during the exchange and consumption phases is related to bad management and a lack of funds. By citing 'bad management' they attribute the problem to an external actor, not to the community of owners. In a way, that perception is consistent with the Colombian horizontal property law. However, a lack of funds is a problem that the manager encounters in the community. The proposed solutions amount to more training for management and changes in norms so that communities can generate income using the common property resources. These solutions are therefore best understood as belonging to the realm of formal institutional change.

§ 6.5.3 Comparison of perceived problems and solutions

In both Bogota and Quito, the professionals involved in housing provision recognized the problems regarding the deterioration process that affordable housing projects are confronting. They had the opportunity to formulate some solutions and discuss these with other professionals. From a comparative point of view, the perceptions of the problems that cause deterioration differ between Bogota and Quito. The divergence is most apparent within the phases of housing provision. Those problems are related to either formal institutions, such as condominium rules, or informal institutions, such as problems in the network or at the level of community governance.

To begin with deterioration problems, in both Bogota and Quito these are perceived to be related with the policy approach. In Bogota, professionals mentioned the

need to take the costs associated with maintenance into account when making a financial analysis of a household's capacity to purchase an affordable house. In Quito, professionals mentioned the problem too, but one that arose later in the process of housing provision, namely during the consumption phase. Secondly, professionals in Bogota were concerned with the low quality of construction, as were their counterparts in Quito. One perceived problem with the initial design of housing policy is related to the rules that apply to housing subsidy holders and the other to the rules that apply to the quality of dwellings. Solutions that were elicited during the second activity of the focus group were correspondingly related to these two topics.

Other perceived problems are related to governance and the implementation of policy. Lack of sufficient information for homeowners was mentioned as one of the problems causing deterioration. Regarding the exchange process in housing provision, professionals in both Bogota and Quito stated that complete information should be provided. That would include education about the law of horizontal property, one's rights, and the obligations of living under a condominium regime. At this level, there was convergence of opinion across the cities. A problem that was mentioned in Quito but not in Bogota concerns a formal rule of condominium: the internal regulation or the statute of the condominium property system. The lack of participation by future homeowners when internal regulations are being drafted is perceived as problematic. In accordance with housing development processes, internal regulations are written by the first owner who signs the declaration of the condominium regime for the land.

In summary, maintenance problems are perceived differently when the timeline of policy implementation is brought into the picture. That timeline is drawn as spanning the provision processes: production, exchange, and consumption. The same difference applies to solutions. Some of these can be implemented from the beginning with a better drafted policy, which would include the role of social manager whose activities begin towards the end of the housing provision process.

In both cities, maintenance problems were seen as starting in the very first part of the process. In Bogota maintenance problems were attributed to policy, but they were attributed to incomplete information and bad construction quality in Quito. In both cities, the law of horizontal property was mentioned during discussions of the transaction phase. In both cities the focus groups emphasized its importance when talking about problems due to a lack of information among co-owners about their rights and obligations regarding the costs and benefits of maintenance. In Bogota, one actor mentioned that the rules could be adapted to the socio-economic environment of the communities and adjusted to the specific affordable housing projects. In Quito, an actor said that the rules are not adapted to accommodate the reality of the projects. In that light, the law itself may be seen as problematic, not only because of the way

it is written but also because of the lack of knowledge about it and uncertainty about how to use it. Regarding the consumption phase, bad management in Bogota is the most recurrent reason that was given for deterioration. In Quito three factors were considered important: lack of community organization; lack of respect for norms and obligations; and the different habits of co-residence in multi-family buildings. An insufficient economic capacity was mentioned in Quito, but not as frequently as in Bogota.

It is therefore interesting that management was recognized in Bogota as playing a key role in keeping up maintenance but not recognized as such in Quito. In Quito, more importance was assigned to characteristics of the community.

§ 6.6 Conclusion

The objective of this chapter was to unravel a set of interlaced perceptions: how professionals see their own role, what they consider to be the causes of maintenance problems, and what kinds of solutions they propose. To structure their responses, the following three research questions were formulated:

- 1 *How is the policy network composed and how can it be characterized? What are the similarities and differences between Bogota and Quito?*

The policy network is complex; it has many of the characteristics described by scholars of governance network theories. The actors engage in interdependent relationships with each other; they exhibit a multiformity of values and goals; and there is closedness of key actors. These are characteristics that work together to explain the complexity of the policy network.

The characteristics of a network need to be understood in terms of the position of each actor: as either public or private; and as external or internal to the co-ownership regime of each housing complex that is built for low-income households. The analyses of interdependencies in the network have shown that the developer plays a complex role. That role is complex not only in the sense of having both an interest in a return on investment and a veto power to stop building affordable housing if there is lack of trust in the policy system. That role is also complex in that sense that it is a dual role: the actor is both owner and developer during most of the provision process. This actor thus possesses important information, whereby it can take advantage of its closedness

characteristic and position to accumulate power. The characteristics of closedness can vary in some ways, mainly with respect to whether the developer is a private entrepreneur or the municipal housing department itself, as in Quito.

Actors such as the property registrar, which is a public institution in charge of the legality and registration of property, hold critical information. That information is needed by the owners and property managers for maintaining the common property. The problem with the role of the property registrar offices is their closedness. They keep the process of registration and the condominium documents underlying it largely inaccessible to condominium owners.

The focus groups identified two actors as critical to network governance: the property manager and the social manager. In both cities the property manager can be a hired professional, though in practice this only occurs in Bogota. Whether this actor is internal or external, public or private, the property manager is involved in a series of interdependencies with other actors in the network.

If the property manager is a hired external professional, its role is not the same as it would be when that actor is a co-owner. Also, if the property manager was hired first by the developer, its role is not the same as it would be if he/she had been hired by the board of co-owners. As governance network theory asserts, the relationships among actors change in response to the position they occupy. The second actor identified as critical by the focus groups is the social manager. A social manager is neither required nor regulated by the law but were invited to join the network to help facilitate sales and, more importantly, to disseminate information about the institutional arrangements of condominium. However, the scope of their role is still highly dependent on the developer during the provision process. They can participate if the developer invites them or hires them to work together. Otherwise they are not part of the process.

- 2 *How do professionals perceive condominium deterioration processes? And how do they deal with it? Do they use the property law? What are the similarities and differences between Bogota and Quito?*

Deterioration of the affordable housing complexes has been recognized by a range of actors -- the developer, the lending sector, the housing ministry, the municipality, the property managers, and social managers -- as a problem that might have different origins during the housing provision process. During the focus groups, the deterioration process was seen to originate not only after low-income homeowners have moved into their new dwellings. It was also attributed to problems that had already arisen during the production and exchange phases. Therefore, other actors are implicated in the causes of deterioration processes.

Developers in Quito as well as in Bogota identified one of the main problems of deterioration as the fact that the costs and benefits of maintenance had not been incorporated in the policy at the time it was drafted, and the fact that maintenance had not been addressed in the planning stage when the construction costs were calculated. The actors complemented their perception of the problem with a solution: to manage maintenance costs and the quality of the building processes through policy. Moreover, they suggested including maintenance costs and responsibilities in a complete information package regarding common property rules. That information could then be shared with future low-income owners. To prepare for co-ownership in condominium, knowledge about costs of maintenance and regulations of the horizontal property regime is considered crucial.

At the end of the provision process low-income owners have to manage their property by themselves. In order to accomplish this, co-owners need to know about and comply with the property law as well as with the rules of community organization and management. Even if the law does not require it, the actors have agreed to bring in some other actors to help with the transition: effective property management or strong community organization facilitated with social management.

As pointed out earlier, professionals at the external level of governance do not perceive a direct relationship with the community as a whole. They only recognize their relations with the individual owners during the sales process and then they bring in the social manager to deal with the community.

The key difference between perceptions in Bogota and Quito is manifest in the role of the property manager in Colombia and that of community organization in Quito. In both places, these roles are regulated in the law of horizontal property, which makes that legislation a major factor in how those roles are perceived. In Bogota, deterioration problems are attributed to bad management or insufficient economic capacity of the owners. Both causes would in turn affect the management role of the property manager and how that role is implemented. In the end, the perception of the role of the property manager comes down to a perceived lack of compliance with legal regulations on management and maintenance.

In Quito, however, the role of the manager is prescribed by law but is neither as prominent as in Bogota nor compulsory. Thus, the group responsible for management and maintenance is perceived to be the community itself. That responsibility lies with the group. It is up to the group to take collective action and develop all the necessary strategies for the upkeep of their common property. There are also problems with leadership and social capital, in the view of the external actors. They perceive failures in organization as being the consequences of insufficient information about the law but

also of a lack of compliance with and knowledge of the condominium regime. And the solution they propose is to guarantee social management during the housing provision process so that owners will be informed about and prepared for the shared living arrangements and the regulations that fall under a condominium regime.

3 *How does the network approach help to explain collective action in the policy network?*

The network approach first helped us to study what occurs outside the common property regime. As set forth in the literature reviewed in chapter 2, Ostrom asserts that collective action theories generally missed the chance to study how external factors might affect the internal common property situations of collective action. The analysis presented in this chapter demonstrates that by applying the network governance perspective to the housing system it is possible to study those external factors, which are actors in a complex network. So doing can help unravel many of the interdependent relationships that are created in the process of condominium housing provision.

Using qualitative methods such as focus groups, with all of the actors in the network gathered around the table, we gave a vivid demonstration of how important it is to have moments to share opinions and to think in a cooperative way, thereby resolving the prisoner's dilemma, to use Ostrom's analogy. People find ways to talk about problems and thus to hammer out solutions by changing or adapting to the rules. This interaction was an important demonstration of how participants could build up their own social capital as a group, as the exercise allowed them to adapt and improve situations for themselves and for others. For instance, they could hire social managers in an effort to change the outcomes. They recognize that the law itself cannot produce the necessary social capital inside the communities of co-owners to keep up on the maintenance of the common property.

This chapter started by citing Ostrom's call for research into how "the activities and policies of external political regimes can affect the level and type of self-organization to achieve collective benefits" (Ostrom, 1990:190), and that is what has now been done here by observing networks in Bogota and Quito. The relationship of the external actors with what needs to occur later among the co-owners was described by the actors themselves. Network theory was used to unravel the perceptions of common property problems and to analyze how professionals can contribute to possible solutions by both respecting and adapting the given rules. The actors did not suggest modifying the law of horizontal property. Rather, they recommended improving the policy rules, a signal that some network steering is necessary. The problem with the law, in their view, lies in the insufficient knowledge about it, regarding both constitutional and operational rules.

Knowledge of what occurs at the external level clarifies what goes on in one part of the condominium housing sector. The next step is to observe how it is perceived internally by co-owners in condominium, which is the subject of the following chapter.



Focus group - Bogota
Photo credit: R.E.Donosó.



Focus group - Quito
Photo credit: R.E.Donosó.

7 Maintenance arrangements in condominium tenure: The household perspective⁶²

According to Ostrom, there are two conditions that can help identify a dilemma of the commons: (1) suboptimal outcomes, and (2) institutional feasible alternatives (Ostrom et al., 2006:16). Under the first condition, the strategies or actions taken by users (or resource appropriators) -- assuming a particular set of rules, technology, and attributes of the community -- will lead to an outcome that is non-satisfactory or not efficient, in the perception of the users themselves. The second condition concerns possible institutional arrangements in which users of the resource can agree to undertake a collective action. The latter condition, institutional feasible alternatives, entails changing or adapting operational rules, taking into consideration the costs and benefits at the individual level that at the same time influence the collective outcome (Ostrom et al., 2006:16). If there are no suboptimal outcomes, there is nothing problematic about a common property resource; and if there is no alternative institutional arrangement that can create better outcomes for both the individuals and the group, there is no dilemma.

Affordable condominium housing in Bogota and Quito fulfills both conditions, although the situation is specific to each housing complex. Some have deteriorated more than others, and institutional arrangements are continuously adapted to each community's situation. For example, in order to make costs more affordable, maintenance work may be done on a community work day or a *minga* (a Quechua word used in Ecuadorian and Peruvian Spanish), when everyone is expected to assist and collaborate on work instead of contributing to a monthly maintenance fee. While *mingas* are common in Quito, households in Bogota organize bazaars or little markets to collect money to cover common property insurance. Both kinds of institutional arrangement are informal, since they are not prescribed by law, but they are often implemented in housing complexes owned by low-income families.

62

The analysis of this chapter was published in the *International Journal of Housing Policy*, co-authored with Prof. Marja Elsinga. Since the theory and methods have already been covered in the previous chapters of this thesis, the analysis based on the multivariate model, in the form in which it was approved for the published article, is included here with permission of the co-authors.

This chapter is focused on internal governance, and the questions it seeks to answer are the following:

- 1 *Which factors are related to the perceived maintenance level (PML) of the common property?*
- 2 *Do these factors differ between Bogota and Quito?*

To answer these two questions, a household survey was undertaken to comparatively analyze maintenance outcomes in Bogota and Quito. The sample of surveyed households (N=414) was drawn from the selected housing complexes in each city.⁶³ The Institutional Analysis and Development (IAD) framework worked out by Ostrom (1990) was incorporated in the questionnaire design: the variables are related to (1) community characteristics, (2) institutions and governance, and (3) resource characteristics.

Section 7.1 introduces the chapter by applying the IAD framework to the condominium maintenance level, explaining how the concepts were operationalized and organized by blocks. Section 7.2 shows how the dependent variable of perceived maintenance level (PML) was calculated, as measured at the household level. Section 7.3 presents the variables and hypotheses as derived from Ostrom's framework, and their relationship is tested at the univariate level.

Section 7.4 then discusses the results of the first multivariate regression model for both Quito (7.4.1) and Bogota (7.4.2). Section 7.5 concludes the chapter by summarizing the results and the factors associated with PML in comparative perspective and by answering the chapter's research questions. These conclusions pertain to conditions in the selected housing complexes of each city. However, the models and key findings presented here are also relevant to a comprehensive study of governance of condominium tenure in cities, since these are models that can be tested or compared to other institutional conditions.

§ 7.1 IAD framework applied to affordable condominium maintenance problems

The institutional analysis and development framework (IAD) can be applied to understand the factors associated with a collective outcome (i.e., maintenance of the common property elements), although this is an individual measure. The outcome is studied as it is perceived by the individual heads of the households surveyed in the selected affordable condominiums. This measure gives us one way to diagnose the problem. The action-situation, namely maintenance, involves participants and their positions. Here, the participants are low- and middle-income households and their position is that of residents, either in owner-occupied or renter-occupied units. Ascertaining what kind of information they possess can elucidate some issues of interest for this analysis: for instance, whether they know their rights and obligations, such as the responsibility to participate in the assembly meeting of homeowners, the obligation to pay the maintenance fee, and a shared responsibility to maintain the common property.

Not every situation in a common property resource environment involves a collective action dilemma. It is important to distinguish between a dilemma of the commons and other types of situations.

§ 7.2 Dependent variable: Perceived maintenance level (PML)

To measure the performance of the condominiums we used the perceived maintenance level (PML) as the dependent variable. Households were asked to grade the level of maintenance (not maintained = 1, maintained = 2, and well maintained = 3) of a total of ten physical elements of the housing complexes that were common property and in common use. The common property elements chosen concerned the land (gardens, parking area, and walkways), the structure (facades, stairs, roofs, and common rooms for meetings), and the infrastructure (water pipes, lighting of common areas) (see Table 7.1). The sum of the scores (a total of 30 points) for the ten elements became the PML index, indicating very low perceived levels of maintenance at a minimum of 10 points and perceptions of good levels of common property maintenance at a maximum of 30 points. The reliability of the different factors related to the common property elements was tested using principal component analysis, obtaining Cronbach's Alpha coefficients of .943 for Bogota and .873 for Quito. These high coefficients indicate

that each element's grading was consistent. Table 7.2 includes the mean of the PML scores for each housing complex surveyed in Bogota and Quito. The differences within housing complexes were statistically significant ($p < .01$) in both countries.

COMMON PROPERTY	BUILDING ELEMENT	
Land		
	(1)	Gardens
	(2)	Parking areas
	(3)	Walkways
Structure		
	(4)	Facades
	(5)	Stairs
	(6)	Roofs
	(7)	Common room (for assembly meeting)
	(8)	Main entrance to complex
Infrastructure		
	(9)	Water pipes
	(10)	Lighting in common areas
Common goods		
		Not included (bank account, office equipment)*

TABLE 7.1 Common property elements in Perceived Maintenance Level (PML)

* Office equipment and bank account in low-income condominiums are common in Bogota but not in Quito.

CITY & HOUSING	COMPLEX CODE	N	MINIMUM	MAXIMUM	PML MEAN	STD. DEV.
Bogota		200	10	30	23,6	5,6
	B01	54	10	30	24,6	5,4
	B02	50	16,3	30	23,5	4,3
	B03	46	10	30	18,8	5,4
	B04	50	17,8	30	27	3,8
Quito		214	10	30	20,7	4,8
	Q01	56	10	30	19,3	4,9
	Q02	52	10	30	21,5	4,8
	Q03	50	11,3	27,5	19,5	3,8
	Q04	56	12,9	30	22,4	4,9

TABLE 7.2 Descriptive statistics of the Perceived Maintenance Level (PML) by case study

The survey included a control question to measure the convergent validity of the PML index. Perceived maintenance levels were expected to be negatively correlated with the costs of the work required to be done on those specific elements of the common property. The participants were asked about the current condition of the common property element and whether or not it needed maintenance, repair, or renovation. If the elements needed repair, this would mean that there were more costs associated with the maintenance score. The negative correlation coefficient in both Bogota (n = 200, r = -.696, p < 0.01) and Quito (n = 214, r = -.5562, p < .01) confirmed the hypothesis that a lower PML reflects the level of deterioration. This provides validation for its use as the dependent variable to measure the perceived maintenance outcome.

§ 7.3 Independent variables: Elements of the action-situation

Table 7.3 lists the topics that were included in the household survey, based on the work of Poteete, Ostrom, and Janssen (2010). *Community characteristics* concern the individual household's socioeconomic conditions, the duration of stay in the housing complex, trust in the board of the condominium, and the amount of social capital. Table 7.4 shows that age and education are significantly related to PML in Bogota but not in Quito. Also, interest in being active on the board and trust in the board were significantly related to PML, both in Bogota and Quito. Finally, the extent to which the inhabitants identify themselves with maintenance problems plays a significant role in Quito.

DEPENDENT VARIABLE: PERCEIVED MAINTENANCE LEVEL (PML)		
BLOCK 1 COMMUNITY	BLOCK 2 GOVERNANCE	BLOCK 3 PHYSICAL CHARACTERISTICS
Socioeconomic attributes	Government organisation	Size of the resource
History of use	Network structure	Quality of human-constructed facility
Trust	Property rights system	Economic value
Social capital		

TABLE 7.3 Blocks of variables associated with the perceived maintenance outcome (based on Ostrom (2007) and Poteete et al. (2010) for condominium maintenance arrangements)

COMMUNITY CHARACTERISTICS	THIRD-TIER VARIABLES
Socioeconomic attributes	Head of household gender (GENDER)
	Age of head of household (H_AGE)
	Head of household education level (EDU_LEV)
	Household income level (INCOME_RANGES)
History of use	Living time in the building or housing complex (LIV_TIME)
	Tenure, or type of occupation (TENURE)
Leadership (trust)	Level of interest in participating in the board (INTRST_BOARD)
	Interest in assuming property management role (INTRST_MNGR)
	Trust in management effectiveness (TRUST_MNGMTCOSTS)
	Trust in manager (TRUST_MANAGER)
	Trust in the board of homeowners association (TRUST_BOARD)
Social capital	How well people know the neighbors (KNOW_NGBOR)
	Collective efficacy (COMM_EFFICACY)
	Identify problems with maintenance (MAINT_PROB)

TABLE 7.4 Community characteristics variables

Condominium property rights and obligations are included within the *governance* block of variables, including the rights and operational rules, as well as monitoring and sanctions that are regulated by the property law. Table 7.4 shows that a number of variables are significantly related to PML: attendance at the general meeting was significant in both cities, while perceived responsibility for maintenance, planning for maintenance, and knowledge about funds were significant in Bogota. Variables regarding sanctions when an owner gets behind with the maintenance fee, including the informal sanction of monitoring, did not have any effect on PML in either Bogota or Quito.

The physical features of the housing complex, such as size and quality, were operationalized as the total number of housing units. The construction quality of the human-built resource was measured with a categorical question that graded the perceived quality of the common property in the built environment. The bivariate analyses found that only the perceived quality of the common property was significantly related to PML in both Bogota and Quito. However, in Quito, PML was also related to the size and quality of the housing units.

The univariate relationship of each variable with the perceived maintenance level (PML) was studied by city. The variables included in the multivariate model are only those that showed a univariate statistically significant effect in PML.

§ 7.3.1 Characteristics of the community (co-owners and tenants)

With regard to household characteristics, the second-tier variables included socioeconomic attributes, history of use, leadership (including signs of trust), and social capital. Third-tier variables such as gender, age of the head of household, household income, and household education level were the socioeconomic characteristics covered in the survey. Table 7.5 presents descriptive statistics for these variables.

		BOGOTA		QUITO	
		Count n=200	Percentage (%)	Count n=214	Percentage (%)
Gender	Male	116	58,0	131	61,2
	Female	84	42,0	83	38,8
Age	18-24 years old	6	3,0	8	3,7
	25-34 years old	59	29,6	42	19,6
	35-44 years old	50	25,1	47	22,0
	45-54 years old	41	20,6	44	20,6
	55-64 years old	21	10,6	33	15,4
	65 years old of above	22	11,1	40	18,7
Education level	Primary school or below	30	15,0	46	21,5
	Basic secondary school	20	10,0	48	22,4
	Higher secondary school	62	31,0	21	9,8
	Technical degree	38	19,0	7	3,3
	University degree or above	50	25,0	92	43,0
Household Income**	\$ 0 - 339	22	11,2	11	5,1
	\$ 340 - 679	62	31,0	45	21,0
	\$ 680 oe 1.019	37	18,5	52	24,3
	\$ 1.020 oe 1.359	23	11,5	40	18,7
	\$ 1.360 oe 1699	12	6,0	19	8,9
	\$ 1.700 or above	40	20,0	47	22,0
Tenure	Owner occupiers	128	64,0	175	81,8
		72	36,0	39	18,2

TABLE 7.5 Socio-economic characteristics of surveyed households in Bogota and Quito

*AGE and INCOME were measured as numerical variables but recoded into categorical variables n=414

**Monthly income values from Bogota were converted into dollars (exchange rate July 2014) and inflated to Colombian consumer price index (December 2014) . Scale is based on Basic Income Salary which is similar in both countries when converted into dollars: \$320 (COL) \$340 (ECU).

Tenure form identifies some elements of the history of use as an owner-occupied or tenant-occupied unit. In Bogota, 64% of the surveyed households are owner-occupiers and 36% are tenants. In Quito, 82% percent are owner-occupiers and 18% are tenants.

Variables regarding norms and social capital concern the extent to which the heads of households know their neighbors, as measured on a three-point scale (not at all, somewhat, or well). In Bogota 24% of the households said that they do not know who their neighbors are, in comparison to only 11% of the households in the Quito housing complexes. A high share of them knows 'some' of their neighbors: 68% in Bogota and 63% in Quito. Those that know all of their neighbors well make up only 8% in Bogota, but in Quito this response was much more common at 25% (Chi-square within cities sig. at $p < 0.01$).

In a separate question, households were asked whether or not they agree with this statement: *In this housing complex the community easily collaborates to keep the complex clean.* They could respond 'agree' or 'disagree'. This item measured the perception of collective efficacy of the group, which is considered another indicator of social capital in the community (Kleinhans, 2007). In Bogota, 39% agreed with the statement while 62% disagreed. And in Quito, 44% agreed while the remaining 56% disagreed.

§ 7.3.2 Rules and governance

Second-tier variables regarding governance are separated into the following groups: (1) government, (2) network structure, (3) property rights system, (4) operational rules, and (5) monitoring and sanctions (Table 7.6).

The role of government in condominiums involves coordination between households and the public sector during the subsidy allocation processes. In Bogota, 44% of households were subsidy-holders while in Quito 50% of households had received the subsidy. Interdependence with external actors, as one characteristic of the network structure (Bortel, van & Elsinga, 2007; Sorensen & Torfing, 2007), was measured by asking the head of household the following: in your opinion, *who is responsible for maintenance of the building or housing complex?* This question was open-ended; the responses were later codified as either internal or external. A high percentage of households in Bogota recognize the property manager as the principal responsible person, while in Quito the responsibility falls under the board of homeowners.

Affordable condominium housing provision often includes the participation of social managers in the housing provision process. The variable 'know rights' is a way to operationalize the influence of social managers and to see if knowing about rights positively or negatively influences PML. In Bogota 58% of households said that they know their rights while in Quito this percentage was 64%.

INSTITUTIONS AND GOVERNANCE	THIRD-TIER VARIABLES
Government	Received (or not) down-payment subsidy (GOV_SUBSIDY)
Network structure	Perceived responsibility for maintenance (MAINT_RESP)
	Received information about rights and obligations (KNOW_RIGHTS)
	Social management (SOC_MNGMT)
Property rights system	Acknowledge existence of the assembly of co-owners (ASSEMBLY)
	Assistance at assembly meeting (ATT_ASSEMBLY)
Operational rules	Proposed rule/change in assembly meeting (PART_ASSEMBLY)
	Planning for maintenance (MAINT_PLAN)
	Knowledge about reserve funds (RSVR_FUND)
	Rule about pets in the building (RULE_PETS)
	Maintenance done by community work day (INFORMAL_COMM_MAINT)
Monitoring and sanctions	Sanction if delays with payment an interest is charged (SANCTION_COURT)
	If delays with payment of maintenance fee (SANCTION_INTRST)
	Non-sanction, if late with payment, property manager awaits (SANCTION_WAIT)
	Knowledge about neighbours being late with maintenance fee (MOTR_INFORMAL)

TABLE 7.6 Institutions and governance variables

Variables about the property rights system were used to find out if both owner and tenant occupants are aware that there is an assembly of owners in the housing complex. In Bogota 88% of households responded yes, while in Quito this percentage was lower at 65%. According to the rules, at least 70% of households need to be present at the assembly meeting in order to make decisions. The percentage of households that never attend the meeting is a sign of high levels of free-riding in the complexes. Attendance at the annual assembly of homeowners is compulsory by law. Households were asked how often they attend the meeting (never = 0; sometimes = 2; always = 3). In Bogota, 38% of households said they never go to the meeting, while 46% always do, and 17% of them attend sometimes. Attendance is higher in Quito:

56% of households always go, while 20% of them never go to the assembly meeting and 25% of households go sometimes.

Regarding the operational rules for maintenance, the survey included questions about participation in the assembly meeting as well as knowledge about three issues: (1) the maintenance plan; (2) the rules on allowing pets in the building; and (3) the existence of a reserve fund. Participation in the assembly meeting means proposing or suggesting a change of a rule to improve maintenance. In that sense, only 25% of households in Bogota have participated in the assembly meeting while in Quito 49% of them have done so. Knowledge about the existence of a maintenance plan is not widespread. Only 37% of households in Bogota think there is one; similarly, in Quito just 34% of households of some kind of plan for maintenance. Whether or not there is a reserve fund for maintenance emergencies is an indicator of the presence of a plan. In Bogota 50% of households responded that they 'don't know' whether the housing complex has reserve funds for maintenance emergencies. In Quito, 35% of households said they did not know about the reserve fund. By law, in both countries communities of co-owners are obligated to create this fund.

A high proportion of households acknowledged the existence of rules or an internal norm regarding whether or not pets are permitted. In Bogota, 87% of households said 'yes', there is a rule for pet management, and a high percentage of them (82%) agreed with the rule. In Quito, 80% of households recognized there is a rule about pets, and 78% of them agreed with it.

§ 7.3.3 Physical characteristics

The unified block of variables regarding the physical characteristics recognizes that resource units' characteristics cannot be physically separated from the common property of the land, the common structure, and the infrastructure of the building. Size, value, and quality are therefore three variables that can be used to operationalize the physical characteristics of housing in condominium (Table 7.7).

RESOURCE PHYSICAL CHARACTERISTICS	THIRD-TIER VARIABLE
Size	Number of dwellings per case (RESOURCE_SIZE)
Human-constructed facility	Perceived construction quality of common property (QTY_COM_PROP)
	Construction year (CASE_YBUILT)
Economic value	Maintenance fee (MAINT_FEE)
	Up to date with maintenance fee (MAINT_FEE_PAID)
	Satisfaction (STISF)

TABLE 7.7 Resource physical characteristics variables

Size is operationalized using the total number of dwellings per complex (Orban, 2006; Yau, 2014). And construction quality is operationalized using the perception of the residents, both owners and renters. In Bogota, 78% of households graded the construction quality of their unit as ‘good quality’, while in Quito this percentage was lower, at 55%. Perceived quality of the common property was also high in Bogota, at 78%, while in Quito it was 62%.

Individual maintenance fees are calculated on the basis of the total monthly cost of maintaining all common property parts divided by the shares (shares based on square meters) owned by each household. By law it should be divided using the participation quota of square meters owned (*alicuota*). In affordable housing projects, however, the units are generally the same size. Therefore, for the calculation of fees, the maintenance costs are divided equally by the number of apartments. It is agreed to pay the fee on a monthly basis, but it is often paid by the project at hand. For instance, the manager may collect money at the moment it is necessary to mow the lawn, which comes down to investing in maintenance on a case-by-case basis. The mean amount of the maintenance fee in dollars in Bogota is \$28.00 while in Quito the mean is \$9.00.⁶⁴ The sample included some free-riders in both cities. In Bogota, 80% of households are up to date with payment, compared to 65% in Quito.

64

Data from Colombia was first converted to US dollars. Then data from Ecuador was inflated to the Colombian prices to make them comparable, using the Consumer Price Index for December 2014.

Community		BOGOTA	QUITO
Socioeconomic attributes	Gender head of household	-	-
	Age of head of household	Yes	-
	Education level head of household	Yes	-
	Household income level	-	-
History of use	Duration of stay in the housing complex	-	-
	Housing tenure, or type of occupation	-	-
Leadership (trust)	Level of interest in participating in the board	Yes	-
	Interest in assuming property management role	-	Yes
	Trust in management effectiveness	-	-
	Trust in manager	-	-
Social capital	Trust in the board of homeowners	Yes	Yes
	How well people know their neighbours	-	-
	Collective efficacy	-	-
	Identify problems with maintenance	-	Yes
Governance			
Government organisation	Received (or not) down-payment subsidy	-	-
Network structure	Perceived responsibility with maintenance	Yes	-
	Received information about rights and obligations	-	-
	Social management	-	-
Property rights system	Acknowledge existence of the assembly of co-owners	-	-
	Attendance of assembly meeting	Yes	Yes
Operational rules	Proposed rule/change in assembly meeting	-	-
	Planning for maintenance	Yes	-
	Knowledge about reserve funds	Yes	-
	Rule about pets in the building	-	-
	Maintenance done on community work day	-	-
Monitoring and sanctions	Sanction if delays with payment of maintenance fee	-	-
	Non-sanction, if late with payment, people wait	-	-
	Knowledge about neighbours being behind with maintenance fee	-	-
Physical features			
Size	Number of dwellings per case	-	Yes
Quality	Perceived construction quality of common property	Yes	Yes
	Perceived construction quality of units	-	Yes
Economic value	Construction year	-	-
	Maintenance fee	-	-
	Up to date with maintenance fee	-	-
	Satisfaction	-	-

TABLE 7.8 Variables tested for significant bivariate relationship with PML, for Bogota and Quito separately

Tests for significance: Pearson's correlation (numerical variables) and Anova (categorical variables), yes = significant

§ 7.4 **Multivariate Regression Model for Bogota and Quito**

The IAD framework was systematically applied in both cities. A multiple regression model using a nested approach with cluster correction was developed to achieve more robust variances (Williams, 2000), realizing that household perceptions might be correlated due to the sample design. The nested approach in STATA is a multivariate regression model. The variables were entered by block, following each conceptual element of the IAD model. For comparative purposes, rather than treating countries as dummy variables, we separated the data. We then developed models for each context, testing significant variables and observing R-square coefficients by blocks.

§ 7.4.1 **Model for Bogota**

From the first block of variables that operationalize community characteristics for Bogota, the variable that corresponds to the age of the head of the household had a significant influence on the PML. Younger households were more critical of maintenance levels than older households.

Education level was significant when the variables of blocks 1 and 2 were entered; however, when block 3 variables were entered into the model, education factors lost their significance. This is an indication that other institutional factors were more relevant than education level. For example, variables measuring trust in the board of homeowners and interest in being part of the board were both relevant measures regarding the role of leaders in the community, with a highly significant effect on PML. As the negative coefficient demonstrates (-2.514, $p = 0.041$), people who have some interest in assuming a role on the board of homeowners perceive more problems with maintenance levels than those who are not interested. Therefore, these are the people who are willing to participate and assume the leadership role necessary to improve maintenance outcomes.

BOGOTA - LINEAR REGRESSION – NESTED

Dependent variable: PML

	Block 1		Block 2		Block 3	
	Coef	t	Coef	t	Coef	t
Variables						
Community						
Age	.07273	2.83*	.0946	4.76*	.07529	3.76*
Education	-2.4320	-2.83*	-2.3057	-3.15*	-1.4256	-1.47
	-.3090	-0.48	-.9596	-1.26	-.1941	-0.19
Trust in board	4.7611	7.21**	3.0494	17.05**	2.1821	3.99*
	4.7955	4.05*	2.9316	4.90*	1.7944	6.79**
	2.8464	1.67	.5918	0.80	.8635	0.83
	-3.9075	-5.21*	-3.3313	-4.03*	-2.3511	-3.48*
	-1.2556	-0.82	-1.2227	-0.76	-1.4663	-0.68
Governance						
Attendance at board meetings			-2.1918	-3.53*	-2.3511	-3.48*
			-1.8927	-4.10*	-1.5946	-3.16*
Feeling responsible for maintenance			-3.4718	-3.68*	-2.9078	-3.16*
Maintenance plan			-2.3738	-6.33**	-2.3769	-11.20**
Rules for pets			-1.46	-4.84*	-1.8338	-3.11*
Physical characteristics						
Quality common property					-3.7826	-5.39*
					-3.4268	-5.08*
	Observations	193	Observations	193	Observations	193
	R-Square	0.2037	R-Square	0.34	R-Square	0.39
			Change in R-Square	0.1422	Change in R-Square	0.0540

TABLE 7.9 OLS nested model for Bogota

Robust Std. Err adjusted for 4 clusters in HOUSING_COMPLEX

*Significant at $p < .05$

**Significant at $p < .01$

Governance variables, such as those related to the network structure (maintenance responsibility), were significant and negative. The PML index for people who placed responsibility on external actors (professionals) was -2.90 points less than the PML index for those who perceived maintenance to be the responsibility of the internal actors such as the residents. Compliance with a property rights regime was measured

by looking at how often people attended assembly meetings. PML in Bogota was negatively associated with attending assembly meetings. Households that attend meetings 'sometimes' or 'always' perceive lower levels of maintenance than those households that never attend. Going to assembly meetings probably encourages a better or more transparent idea of maintenance issues in a housing complex. Variables related to the operational rules of condominiums were significant, with negative coefficients. Furthermore, knowledge about a plan increases the chances of having higher PML.

Finally, the variable that represents the quality of construction of the common property resource influenced the PML index. The relationship was negative, meaning that a good quality of construction was associated with less satisfaction with the current level of maintenance. One explanation for this could be that a good quality of construction makes any lack of maintenance more evident. The other physical characteristics, such as size, did not have any statistical influence on PML.

To summarize, community characteristic variables explain 20% of the variance in PML, and when variables regarding formal institutions are introduced, the explanatory power of PML rises by 14%. Finally, the quality of construction of common property areas increases the explanatory power of PML, leading to a total R-square of 0.40 in Bogota (Table 7.9).

§ 7.4.2 Model for Quito

The first variable regarding an individual's relationship with the condominium community is the level of interest in assuming the role of property manager. According to Ecuadorian law, this position can be filled by any co-owner of the community by being elected the president of the board of homeowners in an assembly meeting. Alternatively, if households are willing to pay for that service, the board can hire an external person or a company as property manager. The low-income condominiums surveyed in Quito did not have external property managers. The results revealed that PML scores change negatively when people are not interested in assuming this role. A high percentage of households not willing to assume a role in management is a sign of lack of interest in assuming leadership in relation to collective action issues.

The second community variable associated with PML was trust in the board of homeowners. Households in Quito have trust in their current board members, and when trust is high, the association with PML is positive.

QUITO - LINEAR REGRESSION – NESTED

Dependent variable: PML

	Block 1		Block 2		Block 3	
	Coef	t	Coef	t	Coef	t
Variables						
Community						
Willing to be manager	-1.2983	-4.56*	-1.5965	-4.60**	-1.5500	-3.06*
Trust in board	3.5112	.8759*	2.9679	4.31*	2.8086	7.50**
	3.9592	2.56	3.4026	2.19	2.7725	2.75*
	1.6050	3.09*	1.7672	4.65*	1.4310	3.40*
Responsible for problems	3.4133	5.38**	3.5547	4.44*	3.2286	3.37*
Governance						
Attendance at board meetings			2.8537	3.80*	2.5762	4.45*
			1.1073	1.28	1.0099	1.83
Physical Characteristics						
Quality unit					.6151	0.59
					2.1956	9.74**
Quality common property					1.1550	2.81*
					2.5514	1.82
Size					-.7995	-1.08
					-1.9766	-6.74**
	Observations	212	Observations	212	Observations	212
	R-Square	0.2167	R-Square	0.2543	R-Square	0.3638
			Change in R-Square	0.0377	Change in R-Square	0.1094

TABLE 7.10 OLS nested model for Quito

Robust Std. Err adjusted for 4 clusters in HOUSING_COMPLEX

*Significant at $p < .05$

** Significant at $p < .01$

Regarding governance variables, attendance at assembly meetings makes households more optimistic about the maintenance level. People who ‘sometimes’ go to assembly meetings had a PML that was 2.5 points higher than those who ‘never’ attend. Physical characteristics such as construction quality were significantly associated with PML. As expected, the better the construction quality, the higher the levels of perceived maintenance. The variable of size was negatively associated with PML: as the size of the complex increases, the PML score decreases.

In summary, individual perceptions and community characteristics explain 22% of the variance in PML, a percentage that increases by four points when the governance variables are introduced and by ten points when the variables regarding the physical characteristics are included. In total, this model explains 36% of the variance in PML among the selected housing complexes in Quito (Table 7.10).

§ 7.5 Comparison of results

The models presented above included variables regarding the three main conceptual elements of the IAD framework: (1) community; (2) governance; and (3) physical characteristics. Below we examine the extent to which the interaction between these variables and PML is similar or different in Bogota and Quito (Table 7.11).

VARIABLES	BOGOTA	COEF.	QUITO	COEF.
Community				
Socioeconomic attributes	Age of head of household	+		
	Education level	-		
Leadership (trust)	Trust in board of homeowners	+	Trust in board of homeowners	+
Norms and social capital	Interest in participating in the board	-	Will to assume a property management role	-
			Concern about maintenance problems	+
Governance				
Network structure	Maintenance responsibility	-		
Property rights system	Attendance assembly meeting	-	Attendance assembly meeting	+
Operational rules	Maintenance plan	+		
	Rule for pets	-		
Physical characteristics				
Size of the resource			Size by number of dwellings	-
Human-constructed facility	Construction quality of common areas	-	Construction quality common property	+
			Construction quality of unit	+

TABLE 7.11 Comparison of variables associated with PML in Bogota and Quito

Dependent variable: Perceived Maintenance Level (PML)

Variables such as the age of the head of the household and education level were associated with small differences in PML in Bogota but were not relevant in Quito. What both contexts reveal is the relevance of informal institutions. For instance, Bogota and Quito exhibit similar levels of trust in the board of homeowners and attitudes towards assuming roles in the management of common property, either as part of the board of co-owners in Bogota or as both owner and property manager in Quito. A specific concern about maintenance levels was a significant variable in Quito but not in Bogota. The effects of this variable can be explained with reference to the governance variables, since in Quito concern about maintenance levels was associated with attendance at assembly meetings.

The establishment of a board is obligatory and generally prescribed in condominium laws. However, whether or not people have trust in the board is something that cannot be regulated. Trust is therefore the result of informal processes or is facilitated through the involvement of social managers, who can help members of a community get to know each other and recognize trustworthy leaders.

An understanding of the condominium structure may explain the difference in levels of trust. In Bogota, some members of the boards have received training in condominium management and community organization. In Quito, however, these kinds of training opportunities are not available to low-income owners, unless a social management entity is hired by a developer. Trust needs to be sustained over time and, therefore, it matters who participates in the board or in management roles. The problem is that participation in the board of homeowners or as a manager is not a popular activity among co-owners in the sample. Consequently, rotation, as one of the democratic principles underpinning the condominium obligations, is difficult to achieve (Yip & Forrest, 2002). To summarize, community characteristic variables in both Bogota and Quito explained about 20% to 22% of the variance in PML.

As expected, and corresponding to one of the most important assumptions in this research project, there are significant differences between Bogota and Quito at the level of institutions and governance that are related to differences in the property law. Specifically, differences are seen in terms of operational rules, such as the use of the maintenance plan and, more importantly, the role of the external property manager, which is regulated in Bogota and not in Quito. Having a maintenance plan is an indication of some forethought regarding deterioration processes, and the significance of this variable with regard to PML proves its interdependence with property law prescriptions.

A similarity between the two countries with respect to governance is seen in the central role of assembly meetings of owners. As seen in the condominium bundle of rights, all five rights and obligations, including voting powers, are exercised during the meetings of homeowners. In Bogota, attendance at meetings makes households more critical about their collective maintenance outcomes. In Quito, attendance at meetings gives people a better idea of what can be achieved and therefore has a positive association with PML. Households in Bogota seem to rely on a well-functioning board and are inclined to attend meetings when not satisfied, while in Quito the opposite occurs. Since there is less trust in Quito, people concerned about maintenance levels are more inclined to attend the meeting of owners and help to improve conditions.

The incorporation of the physical characteristics of the resources in this particular analysis of condominium tenure makes Ostrom's approach appear to be a valid framework to use in the development of a comprehensive institutional analysis of this common property resource. Construction quality was measured in terms of the perceptions of the owners and residents of the housing complexes. In both cities, the quality of construction of the common property was strongly associated with PML outcomes. However, the effects were different in Bogota and Quito. In Bogota, the relationship was negative, while in Quito it was positive. One explanation for this difference may be that there are higher construction standards in Bogota, a condition encouraging a more critical perspective on maintenance levels among households.

The use of resource size as a measure is highly debated in the literature on collective action, and there is no agreement about the effect of the size of the group on collective outcomes. As Ostrom would have expected, there is no definite relationship between size and PML: the size of the housing complex had some effect in Quito but not in Bogota. More important than size is the multilevel structure of governance that a larger housing complex may develop. For example, in Bogota, the largest complex surveyed had an efficient decentralized system of governance that appears to work well, in light of the PML scores. Each housing block has an administrative committee that sends a representative to the main board of owners of the whole complex. The larger housing complexes in Bogota have higher PML scores than the smaller ones. The opposite was found in Quito. There, the largest complex lacked an efficient governance system, as it had no clear physical boundaries for management, which is in the hands of the general board. However, smaller complexes with more clearly defined boundaries for management and maintenance show higher levels of perceived maintenance.

§ 7.6 Conclusion

Most studies acknowledging the dilemma of property rights in condominiums analyze the performance of the condominium using explanatory variables such as household and building characteristics (Orban, 2006; Alterman, 2010; Hastings et al., 2006). Our study also included governance variables and applied the IAD framework to explain the interaction between the formal institution, such as the property law, and the self-organization and participation of co-owners. Using this additional framework allowed us to compare countries and to analyze interactions between the community, the governance structure (enforced by the property law), and the physical features of the condominium.

This design of this study proved to have some limitations. Despite being fully focused on the role of the law, we could not isolate the effect of the law from other factors. We can only infer relationships from our findings and present our reasoning on the relationship between the law and the variables in our survey. Moreover, the dependent variable was the perceived maintenance level, which may be influenced by factors other than the state of maintenance.

Despite these limitations, we think the outcomes can be generalized and applied beyond Bogota and Quito to rationalize condominium mechanisms. The combination of residents' perceptions with other more formal condominium processes demonstrates that governance mechanisms are implied in condominium tenure, creating a bridge between theory and the empirical setting (Bengtsson & Hertting, 2014).

Theoretically, no single variable was more important than any other. Rather, in line with Ostrom's framework, it was their interaction that had an impact on the perceptions of those involved in maintaining the common property in condominium (Ostrom, 2005). Based on the results obtained in this study, if there is (1) trust in leaders of the community, (2) agreement about who is responsible for maintenance, (3) participation in assembly meetings, and (4) adequate physical conditions of the building that can be maintained, the owners are likely to have higher estimates of the benefits (higher PML) than those who do not trust others and do not go to the meetings. One variable that made a significant difference in regression analysis was the knowledge of a maintenance plan. A planning process can be transformed into information and sustain self-organization. Owners collectively need information, as well as knowledge about rules, to be able to manage the condominium complex institutional setting.

The expected result was a positive relationship between self-organization and PML and a higher score on perceived maintenance in Bogota than in Quito. In line with our hypothesis, the results demonstrate that the perceived maintenance level of the cases in Bogota was, on average, higher than in Quito. However, contrary to our hypothesis, participating in self-organization in Bogota had a negative effect on PML, while in Quito it had a positive effect. This differential is mirrored in the negative coefficients between PML and the role of the external or professional property manager, in comparison to the positive coefficient when the property manager comes from within the community. This demonstrates that although the law prescribes the presence of paid property management, norms and trust play a more important role when the community prefers self-organizing for maintenance.

While these findings indicate that the law matters, the relationship between formal arrangements required by law, self-organization, and maintenance outcomes is more complicated than expected. What they also indicate is that the more advanced and formal organization in Bogota appeals in particular to those residents who are less satisfied with maintenance, who then tend to participate. On the other hand, it may be that people are less positive about the maintenance because they are more aware of it. It is important to further analyze this issue in order to find a good balance between formal arrangements in the law and the mechanism of self-organization.

The challenge in Bogota is to maintain the formal structure while promoting greater involvement of the inhabitants. The situation in Quito is different due to the flexible legal context; residents in Quito are more active, and they actually go to the meetings hoping to contribute solutions. The functioning of the network structure of affordable housing provision can benefit from a well-managed and effective meeting of the owners and a board that is capable of governing their common property resource. Physical characteristics such as size had opposite effects in Bogota and Quito, making the importance of this variable debatable, which is in line with earlier work on governance and management of the commons (Orban, 2006).

8 Conclusion: The balance between property law and self-organization

§ 8.1 Introduction

The first question addressed in this thesis was *Why are low-income homeowners in Bogota and Quito letting their condominiums deteriorate?* Narrowing the search for an explanation to the institutional setting, the next question was, *Is there any difference or similarity between Bogota and Quito, considering that each country has a different condominium property law?* As described at the beginning of the thesis, the housing system approach pursued by these two countries is focused on homeownership, though in a particular form of tenure: homeownership in condominium. This tenure was then explored from several angles: What kinds of formal and informal institutions play a role in the condominium regime? How is this form of homeownership to be defined? and, given that definition, How are the problems ensuing from a condominium regime to be studied? The thesis has addressed key elements of the main research questions. These elements were treated in consecutive order, since findings from the first and second part of the thesis formed critical input for the research design and the research approach implemented in the third part of the thesis. Here, in this concluding chapter, the main results are summarized separately for each part. That overview is followed by a reflection on the benefits and limitations of the underlying theory and the methodology used to answer the research questions. Last, some remarks are devoted to the implications for housing policy and future research on the topic.

To recapitulate, as explained in the introduction of this thesis, dwellings are physical structures and by their nature prone to deterioration, so they require maintenance. Therefore some level of human action is necessary to reverse or at least contain the process. Maintenance of a house is not only costly but also requires knowledge about and attention to patterns of deterioration in the materials typically found in each part. If it is a single-family house, this responsibility lies entirely with the low-income household that owns it. And housing policy research has shown how difficult it is for a low-income family to assume those costs. The affordability of maintenance

raises concerns about whether low-income families are actually capable of being homeowners in the long run.

The situation of low-income homeowners in condominium is somewhat different, however. Because their property is in part shared with others, maintenance is not an individual responsibility but a collective one. Institutionally and physically, owning a single-family house in individual property is not the same as owning a house or an apartment under the horizontal property or condominium regime.

The research was conducted in two Latin American urban contexts: Bogota and Quito. In general, housing policy in Latin America promotes homeownership. For low-income families, homeownership is highly subsidized, and Bogota and Quito exemplify these particular kinds of policies and problems.

Dwellings for low-income households started to be provided in multi-family buildings during the mid-twentieth century. To that end, a modern form of property that was already well established in Europe was adopted in Latin America: the condominium, or the horizontal property regime. The South American country with the most up-to-date law on horizontal property (re-written in 2001) is Colombia. Ecuador, in contrast, is one of the countries that still works with its first law, enacted in the 1960s, though some key amendments were introduced in 2011 and 2015.

To shed light on the deterioration path of affordable housing, this study relied on the comparative housing system approach, as it embraces the institutions and governance of a property regime that has been produced under housing policy mandates. The reason to focus on institutions and governance is explained below with reference to Elinor Ostrom's framework for studying common property regimes, the Institutional Analysis and Development Framework (IAD). That theoretical frame is appropriate because it covers formal and informal institutions, both of which play a role in maintaining physical elements of the common property resource.

§ 8.2 Results

The problem underlying this research is scrutinized by posing different questions for each stage of the research. However, an overriding hypothesis was formulated as a possible explanation of the observations regarding institutions. Pursuing that hypothesis, we could investigate whether any differences that might show up between

the Colombian and the Ecuadorian cases may be attributed to differences between the respective property laws for condominium ownership. The rationale runs as follows. Although self-organization is prescribed by law, it develops informally; in theory, formal institutions have a particular role to play in collective organization. The perceived maintenance outcomes would presumably be more satisfactory in Bogota than in Quito due to Colombia's more structured and contemporary law. Hence the hypothesis:

The more contemporary property law in Colombia has a positive impact on self-organization and in turn on the perceived maintenance level.

Part 1. Theory and methods

To find evidence in support of this hypothesis it was necessary to consider which theories would be helpful in explaining the condominium deterioration problem. Part I of the thesis presented a theoretical framework in which to place the institutional debate on collective action and the commons within the realm covered in the comparative housing systems literature. Since the problem involves a common property regime, it was necessary to couch the middle-range institutions and governance framework of the comparative housing system in broader theoretical concepts, which Ostrom's IAD framework provided. It is important to take the meaning that tenure has in a particular housing system into account when making comparative policy assessments, and that factor is given due consideration in this thesis. Both formal and informal institutions come into play when investigating the form of condominium tenure.

Chapter 2 elaborates on the debate about universalistic versus particularistic approaches to comparative housing research, explaining the level of generalization that each may have when comparing policy systems. The core issues in the debate come to light when a middle-range approach is applied. Such an approach can bring historical, cultural, or other ideological arguments to bear on the convergence or divergence among the countries under comparison. The middle-range approach identifies patterns and typologies, proposing three preconditions for a comparative study of housing systems: commensurability (forms of tenure can be comparable), context, and theory. Scholars endorsing a middle-range approach call for more qualitative research when defining the three conditions and while developing the comparative analysis (Haffner, Hoekstra, Oxley & van der Heijden, 2009).

The challenge was to identify theories that can explain the collective action dilemmas of common property resources, which are dilemmas that often arise in low-income condominium tenure, and incorporate these theories in the comparative housing research approach. In a common property regime, many factors appeared to play a role. Therefore it was useful to apply Ostrom's institutional framework; it provided a theoretical institutional backdrop against which to place both the formal and informal rules of the game. From that perspective, the main institutions of the tenure form and the physical characteristics of the resource played an important role, along with the influence of professionals and policy actors, in the maintenance outcomes of this particular property regime. This body of theory recognizes these factors as part of a system of actors and institutions. Therefore it was possible to apply it in conjunction with the comparative housing and governance network approaches.

The reason to select and compare low-income condominiums was to understand how the institutions of the condominium form of tenure differ from each other. Specifically, the goal was to ascertain whether one law, in one context, actually makes a difference when it is compared to a different law in another context. The study turned first to the formal institutions that constitute the bundle of rights of actors involved in condominium ownership; for instance, attention was first drawn to the property law and how actors interpret and use it. Some researchers have remained at that stage and, following Williamson, explained the top-down approach to a collective action solution in terms of regulation (Olson, 1965).

The notion that homeowners have a bundle of rights does not imply that we are studying selfish rational individuals; rather, we are studying residents operating within certain boundaries. Those boundaries may be based on trust and knowledge about each other (informal institutions), or they may be based on compliance with the law (formal institutions). Therefore it is useful to combine Ostrom's framework with Williamson's approach to governance. Both top-down and bottom-up institutional solutions for governance can be found in the condominium regime. The two types are even necessary for sustainable self-organized communities to thrive. Ostrom's framework recognizes the role of collective arrangements that arise informally, such as trust, leadership, and learning processes within governance structures, as variables that might influence collective actions. This integration of formal and informal arrangements is important in this thesis. The study underlying it is about people's homes, which are not just buildings. They are structures that are imbued with emotions and they afford social relations among members of the households and with neighbors.

The statement of the problem for this research was commensurate with the mixed-methods approach that has been applied throughout the thesis project. In chapter 3, all methods were described and the strategies were laid out. The different levels of

information and actors to be studied were introduced, and two approaches, namely Ostrom's framework and comparative housing systems, were integrated to allow a mix of qualitative and quantitative methods.

Part II. Formal institutions

Chapter 4 dealt with the policy for low-income homeownership. It elucidated the formal process of regulation by policy and decree that had created the system whereby professionals became involved in the provision of condominiums. The following questions were developed to guide the research:

How have housing policies been adopted in Colombia and Ecuador? How does the incentive-based policy work when producing condominiums? What are the differences or similarities in policy and market between Bogota and Quito?

Housing policies in both Colombia and Ecuador are framed under each country's constitutional housing rights with a particular emphasis on homeownership. There are policies that focus on informal settlements and other policies that promote new construction of affordable dwellings for low-income families. National governments have intervened in different ways over the decades. This chapter demonstrates that even though government strategies have shifted towards a more systemic approach to housing provision, now including the private sector, there is path dependence in policies for owner-occupation. This trend is evident from the figures on housing included in the analysis of market and census data that were presented in chapter 4.

The main idea behind the incentive-based housing program is to create a system of housing provision for low-income families that keeps the construction industry incentivized to build affordable dwellings. The goal is to have a network of both public and private actors to create a market of low-cost housing for low-income owner-occupation. The effects of such a program are more evident in Bogota than in Quito. In Bogota it is easier to find housing developers whose portfolios include the provision of subsidized dwellings.

Both the public and the private sector are able to find suitable land where they can build in accordance with the prevailing norms for urban development. In both cities, these norms are formulated to promote compact and dense development. Standardized forms of construction and design for multi-family or collective types

of housing are used by developers, who thereby take best advantage of the allowable density in land development. Since the apartments will be sold, architectural regulations and norms that apply to condominiums come into play. For instance, if the policy called for rental housing, the property of the plot of land could remain as either public or private, and this will steer who is responsible for management and maintenance.

Both countries have had policies and programs to support the provision of housing for owner-occupation since the mid-twentieth century, and Colombia had them even earlier than Ecuador. The focus of the market analysis was not to examine affordability or quantitative deficit but to characterize the condominium housing market in these two capital cities. It was therefore necessary to gather cadaster data. It revealed that 65% of the dwellings in Bogota are under the condominium regime, while in Quito 45% of the titles in the cadaster were in condominium in 2011.

The sections introducing the policies earlier in this thesis identified different actors as playing critical roles in the system. In Bogota, the role of the Welfare Family Agencies is pivotal within the subsidy allocation system and in housing provision as those agencies are builders too. Since these private institutions with a public purpose have direct relationships with the future homeowners, they know their target group's housing demands. Therefore these Colombian agencies can organize housing provision more efficiently than seems possible in Quito.

In Ecuador, the subsidy allocation system is managed by the Ministry of Urban Development and Housing in conjunction with its provincial offices. The ministry registers and certifies developers as affordable housing providers. Only those that are registered are able to build and sell affordable housing because they can receive the subsidies upfront, which is an incentive for developers.

The existing data, or the absence of it, justified both the research approach set forth at the beginning of this thesis and the comparative analysis that was presented in subsequent chapters. Furthermore, the existing data also demonstrated the extent to which the condominium form of tenure is overlooked in the current body of housing analysis as well as in statistics on policy outcomes.

Chapter 5 described and compared how the condominium laws operate in Colombia and Ecuador to answer the following subset of research questions:

What and who is regulated by the horizontal property law? How does the regulatory system work in condominium? What are the similarities and differences between Colombia and Ecuador's horizontal property laws?

The chapter analyzed each country's horizontal property law as the main formal institution of the condominium regime. Even though there are other rules impinging upon the system of condominium housing provision -- such as subsidy regulations or municipal license norms -- the horizontal property law is the regulatory body of legislation that prescribes who can be involved as agents in the common property that will be constituted, self-governed, and maintained.

Regarding the main differences between the laws, it was found that Colombia regulates the moment when the assembly of owners should be first constituted. It is also mandatory in Colombia for the developer or first owner to pass the self-governance responsibility on to the owners. To summarize the situation in Ostrom's terms, the common property resource in Colombia has a collective-choice rule nested in a constitutional one, which is a very important condition for creating the governing body of the condominium. In Ecuador, although the collective-choice rule to constitute the first governing body is defined, there is no obligation for the first owner or developer to call the first assembly meeting. Thus, Ecuadorian law leaves ambiguity in this process when the condominiums are new. The law is different when they are old; then there is a collective-choice rule that owners can use to call an assembly meeting if necessary.

Part III. Informal institutions and governance

Chapter 6 studied the network and governance of the professionals involved in the provision of low-income condominiums. And the following research questions were posed:

How do professionals perceive maintenance problems? How do they deal with maintenance? How do they perceive the role of the law? What are the similarities and differences between the two countries in this regard?

Maintenance problems were recognized by the developer, the lending sector, the housing ministry, the municipality, property managers, and social managers. In short, all of the professionals involved acknowledged that communities of homeowners have difficulties with the maintenance of their common property.

During the focus groups, issues were brought up regarding the causes of and solutions for deterioration process. These issues were treated not only as problems that originate once low-income homeowners have moved into their new dwellings. They also turned

out to be problems that already existed during the production and exchange phases of housing provision. Therefore, it was concluded that other actors besides the owners are involved in the causes of deterioration.

Developers in Quito as well as in Bogota regarded one of the main problems of deterioration to be the fact that condominium maintenance costs and benefits had not been incorporated in the policy when came into effect or when the dwelling costs and construction were being planned. The perception of the problem was complemented with a corresponding solution as stated by the actors themselves: maintenance costs and better quality of building processes need to be managed by policy. Moreover, maintenance costs and responsibilities include the incorporation of structured situations in which complete information regarding common property rules can be shared with future low-income owners. For this solution to be feasible, knowledge about the law and regulations of the horizontal property regime must become disseminated.

Ostrom's call for more attention to how "the activities and policies of external political regimes can affect the level and type of self-organization to achieve collective benefits" (Ostrom, 1990:190) has been followed up by studying the networks of Bogota and Quito. Ways in which the external actors could engage with what needs to occur later among the co-owners were identified by the actors themselves. The network theory proved a useful basis for unraveling the perceived common property problems and eliciting comments on how professionals contribute with possible solutions by both respecting and adapting to the given rules. Professionals did not suggest modifying the law of horizontal property; rather, they suggested improving the policy by adapting the rules. In short, they recognized that network steering is necessary but acknowledged that modifying policy is more feasible than changing the law. For the most part, they saw the problem with the law as a lack of knowledge about it, particularly about its constitutional and operational rules regarding condominium governance and maintenance that fall under the collective rights and obligations of the homeowners.

Chapter 7 looked at the situation from the perspective of the residents, examining the governance arrangements around the perceived problem of maintenance. Their overriding concern was whether they knew their rights and obligations regarding maintaining the common property. This concern led to the following research questions:

Which factors are related to the perceived maintenance level (PML) of the common property? Do these factors differ between Bogota and Quito?

These questions were approached using quantitative methods. A survey was designed to elicit how residents perceive factors related to both formal and informal institutions of the common property following, using the Institutional Analysis and Development Framework (IAD). Factors in the IAD framework were divided into three groups: (1) characteristics of the community; (2) governance characteristics; and (3) physical characteristics of the resource. These factors were then tested with regard to collective outcomes of study such as maintenance. The perceived maintenance level was measured at the household level.

We expected to find a higher score on perceived maintenance in Bogota than in Quito. Some of the results were in line with our hypothesis: the level of perceived maintenance was higher in Bogota, on average, than in Quito. However, contrary to our hypothesis, participating in self-organization in Bogota had a negative effect on PML, while in Quito it had a positive effect. That discrepancy is mirrored in the negative coefficients between PML and the role of the external or professional property manager, in comparison to the positive coefficient when the property manager comes from within the community. Although the law determines the presence of paid property management, norms and trust play a more important role in self-organized maintenance.

These findings indicate that the law does matter. Nonetheless, the relationship between mandatory formal arrangements, self-organization, and maintenance outcomes turned out to be more complicated than expected. What the findings also indicate is that the more advanced and formal organization in Bogota appeals particularly to people who are less satisfied with maintenance, and these are the ones who tend to participate more. On the other hand, people might be less positive about the maintenance because they know more about it. Further analysis is warranted to find a good balance between formal arrangements in the law and the mechanism of self-organization.

The challenge in Bogota is how to retain the formal structure while promoting greater involvement of the inhabitants. The situation in Quito is different due to the flexible legal context, which encourages the inhabitants to actually go to meetings in the hope of contributing solutions. The network structure of affordable housing provision could function better if the condominium operated under a well-managed and effective assembly of owners, with a board that is capable of governing their common property resource. Physical characteristics such as size, which had opposite effects in Bogota and Quito, make the importance of this variable debatable, as suggested in earlier work on governance and management of the commons (Orban, 2006).

Theoretically, no single variable is more important than any other one; rather it is their interaction that explains the perceptions of those involved in maintaining the common property in condominium (Ostrom, 2005). Based on the results obtained in this study, if there is (1) trust in leaders of the community, (2) agreement about who is responsible for maintenance, (3) participation in assembly meetings, and (4) adequate physical conditions that can be maintained, the owners are likely to have higher estimates of the benefits (higher PML) than inhabitants who do not trust others and do not go meetings. One variable that made a significant difference in the regression analysis was knowledge about a maintenance plan. A planning process can be transformed into information and sustain self-organization. Owners collectively need information, as well as knowledge about rules, to be able to manage the complexity inherent in the condominium regime.

In summary and in response to the main hypothesis:

- 1 There are important differences in the property laws and this divergence may have an effect on maintenance outcomes. For instance, the presence of a property manager is obligatory in Bogota, whereas in Quito this actor is not mandatory. Instead, the role of property management can be assumed by the president of the board of homeowners in Ecuador.
- 2 The property law of Colombia states that the developers or initial owners of the land have the obligation to arrange for temporary property management. Moreover, after selling 51% of the dwellings, they should pass full management responsibility on to a newly formed board of homeowners. Developers in Bogota often hire social managers to facilitate this transition. In Quito, management responsibilities while units are still being sold are not regulated. Hiring of social management often occurs informally in Quito due to the complexity of the provision process in this tenure. Social managers share information about the rights and obligations of homeowners in condominium.
- 3 Problems of deterioration are perceived by the external policy network in both Bogota and Quito as issues that arise due to a lack of knowledge. According to those external actors, people should know more about the law as well as about the condominium arrangements that are necessary to keep up with maintenance on the buildings. However, given that the laws differ, particularly regarding property management, in Bogota the problem is also said to be related to 'bad management' and in Quito to the lack of strong community organization.

In light of the evidence presented in this thesis, the hypothesis formulated above - '*The more contemporary property law in Colombia has a positive impact on self-organization and in turn on the perceived maintenance level*' - has been 'falsified'. As the research

demonstrates, institutions such as those regulated by the law -- for instance, the obligation to attend an assembly meeting of homeowners -- have a negative impact on self-organization in Bogota and, in turn, on the perceived maintenance level. Additionally, the Colombian law assigns the property manager a central role in maintenance. Therefore, owners take their responsibility lightly and lose interest in participating in the assembly of owners.

The opposite occurs in Quito, where the rules set forth in the law for maintenance arrangements in low-income condominiums are more flexible. There is no obligation to hire a property manager, so the president of the board can assume that role. In this context, participation in the assembly meeting, as required by law, has a positive effect on the perceived maintenance level. The reason is that the co-owners are more involved in the decision-making and have a better idea of the maintenance situation of their common property.

Nevertheless, the law is crucial to achieving better maintenance outcomes, as demonstrated in the Bogota cases. The legal obligation to have a property manager is assumed by the developer, as the first owner. Colombian law requires that the initial owner has to hire a provisional property management; therefore, maintenance arrangements are established early, before the materials actually deteriorate. By the time the common property is transferred to new low-income owners, the maintenance arrangements and costs have already been established and the fees have been set. As set forth in the IAD framework, when the benefits and costs are known, thereby setting the rules of the game, the outcomes are more satisfactory.

The old adage 'My home is my castle' is not apt for condominiums, as one's home is then 'our' castle. As cities grow and communities are built up in higher density, the meaning of homeownership changes. Therefore, different tools and strategies are needed to deal with maintenance problems. With respect to housing policy, when homeownership is not individual but collective, outcomes such as maintenance have to be incorporated in the policy evaluation. Our findings can contribute to a better understanding of the condominium tenure and its role with respect to maintenance and the risk of deterioration of common property in the context of housing policy for low-income homeownership.

§ 8.3 Discussion

This study of affordable condominium housing in two Latin American countries makes an original contribution to the housing policy literature, in the sense that this tenure form is treated here as a common property resource with particular institutional characteristics. In that regard, the added value of this study lies in its contribution not only to the housing policy literature but also to the theory and methodology of housing research. During the research process some limitations had to be overcome, which led to some adjustments in the research design.

Theory

The added value that this thesis brings to the housing policy literature lies in the exposure it gives to the Latin American experience with low-income homeownership. Less often studied than informal self-built settlements, this policy is mostly known for its subsidy allocation system and not for the form of tenure involved, in this instance the condominium. Once it is recognized as problematic, the tenure form opens up new horizons for research. It can branch out into the whole area of complex governance structures involved in the provision of housing, an area that is for the most part unstudied. So far, few Latin American studies have recognized that subsidized multi-family buildings are on a trajectory towards deterioration. Moreover, by overlooking the evidence that housing development is increasingly shifting toward the condominium form of tenure, both policy and urban design could make mistakes that will affect the owners of these projects.

The arguments presented in this thesis weigh into the housing theory debate by recognizing that homeownership is not individual but collective when the owners are in condominium regime. Welfare theories of housing are often focused on individual benefits and outcomes. But how well do these theories fit the evidence when housing is in collective ownership? Even though the thesis does not go deeply into welfare theories, learning about Latin American housing policy for low-income homeownership might be an eye-opener to scholars contemplating comparative research on this topic. Bringing theories of collective action and governance of the commons into the arena of housing theory and housing markets suggests many promising avenues of research. Whereas property is generally understood as an individual good, the condominium breaks that mold: it is certainly a hybrid form of property, and moreover one that exists all over the world.

In 2009, Williamson and Ostrom were awarded the Nobel Prize jointly, as both emphasized the importance of institutions when studying governance. Oliver Williamson received the Prize for his work on the role of institutions in overcoming opportunism in firms that hold assets, and Elinor Ostrom received it for her work on institutions in the governance of common pool resources (Earl & Potts, 2011). Both Laureates are concerned about free-riding problems in governance when managing a common asset. Although they both reaffirm the role of the rational individual in initiating collective action to achieve common goals, they take a slightly different approach to the role of institutions, formal and informal. One can imagine turning to either of these Laureates, however, for guidance when studying the condominium regime, as both of these theories and approaches merge. That said, Ostrom's approach is more general and does not exclude the combination of theories because it is interdisciplinary. As Earl and Potts (2011) argue, "this award should be seen as a boost for the behaviourally founded, evolutionary-institutional approach to economic analysis as a branch of complex system theory" (p. 2).

Methods

If housing is not an individual but a collective good, then other methodological approaches are necessary. Ostrom's framework is amenable to a study of common property resource institutions because it helps the researcher diagnose the problem. Moreover, its methodology is easily replicable in other contexts since it acknowledges that each context has particular practices.

Deterioration, entailing the need for renewal of common property elements such as facades or even of complete buildings, is evident in many countries. The features of the phenomenon are similar despite diverging institutional, social, and economic conditions. According to the literature and the empirical knowledge on condominium problems, difficulties with governance and management are not confined to low-income properties. Therefore, the same research methodology can be applied to all condominiums in the housing market.

The second part of the thesis required field research using both qualitative and quantitative methods to collect data. To study how formal and informal institutions work from the perspective of professionals in the building industry and policy actors, focus groups were held in Bogota and Quito. In that setting the problem and possible solutions to it were discussed. This qualitative approach was useful; it allowed the investigator to see how the actors in the policy network were interacting and discussing a topic. In the end, the topic appeared to be a common problem that they all recognized.

To study the condominium regime among low-income homeowners, it was necessary to design and carry out my own survey. It was administered to 414 households in total (Quito and Bogota) in 2014. The survey was designed with the Institutional Analysis and Development framework in mind. Therefore, it included questions about formal and informal institutions, the physical characteristics of the resource, and socioeconomic characteristics of the household.

The mixed-method approach was necessary to elucidate the relationship between formal and informal institutions in condominium because it places actors in their own context. In that sense this methodological choice concurs with the middle-range approach that is followed in comparative housing studies.

Risks of fieldwork

One limitation encountered during the exploratory phase of the research was the difficulty of contacting and gaining access to those condominiums that have the most serious maintenance and organization problems. At some of the buildings and housing complexes, no one wanted to speak with or even open the door to a researcher who asked how they manage the building or if they were doing anything at all about maintenance. Moreover, some condominiums are located in distressed areas, and it was not safe for a lone researcher to wander around, nor was it even safe for a group of young professionals to survey the residents.

§ 8.4 Future research and data collection

The findings presented in this thesis will hopefully contribute to a better understanding of condominium ownership. However, both the findings and the methodology developed for this project may have some implications for further research as well as for housing policy in Latin America and beyond.

Implications for further research

Innovation is urgent in the way housing data is collected at both the national surveys and the policy monitoring and evaluation. Only with more targeted data will it be possible to observe conditions such as the maintenance level of common property

elements, the existence of a working condominium association and board, and compliance with other rules established by condominium laws. Quantitative data needs to be supported with qualitative data in order to understand the informal means by which co-owners keep some degree of organization in their properties. The value of that combination has been demonstrated by this research.

If a city has a high percentage of dwellings under the condominium regime, housing market analysis must take that tenure form into account. The condition of the common property might affect property values, as it already affects the municipal appraisal for property taxes. And here, 'condition' refers not only to deterioration but more generally to the existence of common property. For example, the value could reflect the existence of a lobby area on the premises, compared to a building that does not have a lobby. Research on housing markets can help define the components of prices and put a value on design elements, thereby providing information to complement research on housing preferences too.

Deterioration of common property elements might have an effect not only on the building but also on the neighborhood. Conducting more research on neighborhood effects could shed light on condominium tenure phenomena at the urban scale.

The collected information can be utilized not only in the realms of policy and academia. It can also serve professionals involved in condominium management and maintenance, as well as the financing sector. The sector of professional services to buildings is an important job market. In this regard, Bogota is a better example than Quito, even though both cities have a whole market of professionals that offer management services to condominiums.

This research has proposed a framework within which comparative housing research on condominium tenure can be continued around the world. This tenure has been so thinly studied and rarely compared that it offers promising avenues for novel research. The groundwork done in the present research can surely be expanded upon, since cities are composed more and more of condominiums rather than single-family dwellings. Much can be learned from a comparison of self-organized communities to privately managed ones.

Implications for housing policy

With respect to housing policy evaluation of low-income homeownership programs, collective outcomes such as maintenance need to be incorporated. The efforts made by the actors in the housing system to produce not only dwellings, but housing complexes

with common green areas and other facilities should be taken into account into policy evaluation.

Climate change is steering housing policy in new directions. For instance, the renovation of the built environment is now expected to meet higher construction and habitability standards. This new vision will also have an impact on the condominium sector. There, renovation requires the same collective decision-making process as maintenance, since the facades, for instance, are collective elements. For that reason, financing mechanisms need to be expanded to include new lending products for condominium renovation and upkeep.

Natural disasters pose well-known threats in Bogota and Quito. The reconstruction of a condominium after an earthquake requires collective all-risk insurance. The experience of the earthquake that occurred along the coast of Ecuador in April 2016 was a hard lesson for owners of beach apartments in condominium. The reconstruction of tourist towns is being delayed due to the lack of collective insurance that would pay for rebuilding. The cost of this delay weighs not only on the owners that lost their property but on the town as a whole.

Cities with numerous properties in condominium, for residential or commercial purposes, should be obligated by government to buy all-risk insurance for their buildings. If collective action dilemmas prevent the purchase of that insurance, policy should come into play to generate sufficient mechanisms to guarantee coverage. Housing policy is part of a wider range of policies to make cities more resilient to natural disasters.

Appendix

Appendix A List of interviewees in Bogota and Quito

INTERVIEWS					
No.	dd.mm.yyy	Place	0h0'	Name	Actor position
01UIO11	25.03.2011	Quito	30'	Juan Manuel Najera	Fundacion Bien Estar
02UIO11	13.05.2011	Quito	50'	Juan Manuel Najera	Fundacion Bien Estar
03UIO11	25.05.2011	Quito	2h21'	Dra. Ma. Paula Romo Meeting at National Assembly of Ecuador	Justice Commission of the National Assembly of Ecuador. Reforms to the Law of Horizontal Property
04UIO11	28.05.2011	Quito	2h	Sr. Carvajal	President of Board of Co-owners Luluncoto Condominios
05UIO11	29.05.2011	Quito	28'	Patricio Gallegos	Resident and co-owner of condominium unit in San Carlos
06UIO11	02.06.2011	Quito	44'	Jenny Ruiz	Asociacion Mujeres Luchando por La Vida
07UIO11	21.06.2011	Quito	45'	Ec. Pablo Valencia	Fundacion Bien Estar
08UIO11	22.06.2011	Quito	1h10'	Ing. Jijon	Project Management Mutualista Pichincha
09UIO11	27.06.2011	Quito	23'	Ing. Miguel Aguas	Catastre office,
10UIO11	28.06.2011	Quito	24'	Homeowner since 1974	San Carlos. Edf. Salinas
11UIO11	03.07.2011	Quito	23'	Alexandra Mina	Coordinadora Asociacion Mujeres Luchando por la Vida . Homeowner in Alba Azul I
12UIO11	05.07.2011	Quito	37'	Arq. Nury Bermudez	Asesora de la Seceataria de Territorio Habitat y Vivienda, MDMQ
13UIO11	06.07.2011	Quito		Carlos Espinel	Direccion de Gestion Territorial, MDMQ
14UIO11	07.07.2011	Quito		Dr. Rodrigo Calvachi	Judirical Asesor in property titling
15UIO11	08.07.2011	Quito		Ec. Diego Aulestia	Gerente Banco del Estado Ecuador
16BOG11	12.07.2011	Bogota	2h18'	Dr. German Molano	School of Horizontal Property Management
17BOG11	12.07.2011	Bogota		Arq. Eduardo Pelaez	AVP ,
18BOG11	12.07.2011	Bogota		Arq. Valentina Pelaez	AVP, Project Management
19BOG11	13.07.2011	Bogota		Lina Plazas	AVP, Commercial area
20BOG11	13.07.2011	Bogota		Hernan Dominguez	FNA National Savings Fund
21BOG11	13.07.2011	Bogota	15'	Dra. Juliana Restrepo	Curaduria No. 4
22BOG11	13.07.2011	Bogota	30'	Dr. Jaime Serrano	Norco - inmobiliaria

>>>

INTERVIEWS					
No.	dd.mm.yyy	Place	Oh0'	Name	Actor position
23BOG11	14.07.2011	Bogota	39'	Delly Betin Aguas	Horizontal Property Manager
24BOG11	14.07.2011	Bogota	27'	Pedro Garcia	President of Condominios II
25BOG11	14.07.2011	Bogota	30'	Cristina Arizaga	Cohabitation Committee, Condo- minios II
26BOG11	16.07.2011	Bogota	38'	Milton Rodriguez	President Administration Council of Conjunto El Cerezo, USME.
27BOG11	21.07.2011	Bogota	32'	Dr. Alejandro Florian	Habitat for Humanity, Colombia
28BOG11	23.07.2011	Bogota	21'	Dra. Laura Salamanca	Corporacion Responder
29BOG11	24.07.2011	Bogota	2h	First General Assembly of Co-Ow- ners	Conjunto El Cerezo, USME.
30BOG12	30.08.2012	Bogota	50'	Arq. Juan Yunda	Taller de la Ciudad, Secretaría del Hábitat. Alcaldía Mayor de Bogota
31BOG12	30.08.2012	Bogota	35'	Mónica Aldana y Dra. Claudia Yopez	Curaduría no.1
32BOG12	30.08.2012	Bogota		Mónica Aldana	Land and development projects
33BOG12	30.08.2012	Bogota	51'	Dra. Claudia García	Amarilo, Legal Department
34BOG12	30.08.2012	Bogota	1h	Juan Carlos Vargas	Notary No.42
35BOG12	31.08.2012	Bogota		Miguel Angel Poveda	Property Manager (enc.) CUAN
36BOG12	31.08.2012	Bogota		Arq. Olga Lucia Ceballos	INJAVIU, Javeriana University
37BOG12	01.09.2012	Bogota		Ec. Jorge Erique Torres	CENAC
38BOG12	01.09.2012	Bogota	1h30'	Dra. Laura Salamanca	Corporación Responder Diplomado Administradores de Propiedad Horizontal
39BOG12	03.09.2012	Bogotá	54'	José Antonio Reina	DAVIVIENDA Puerta Grande Agency
40BOG12	03.09.2012	Bogotá	32'	Jose Andres Rios Vega	Inspección Vigilancia y Control de Vivienda de la secretaria del Hábitat. Alcaldía de Bogotá
41BOG12	03.09.2012	Bogotá	15'	Dra. Adriana Niño	Inspección Vigilancia y Control de Vivienda de la secretaria del Hábitat. Alcaldía de Bogotá
42BOG12	03.09.2012	Bogotá	15'	Arq. Gonzalo Peña	Inspección Vigilancia y Control de Vivienda de la secretaria del Hábitat. Alcaldía de Bogotá
43BOG12				Oscar Alejandro Romero	Property Registry Bogota
44BOG12	04.09.2012	Bogota		German Bulla Montaña	Nodo Distrital de Propiedad Hor- izontal
45UIO12	xx.10.2012			Arq. Ruben Paredes	Asesor subsecretaria de vivienda
46UIO12	10.2012	Quito	1h8'	Arq. Sixto Duran Ballen	Former President of Ecuador
47UIO12	11.2012	Quito	1h	Arq. Silvana Ruiz	CIUDAD
48UIO12	17.12.2012	Quito	53'	Ec. Pablo Valencia	Fundación Bien Estar

>>>

INTERVIEWS					
No.	dd.mm.yyy	Place	Oh0'	Name	Actor position
49UIO12	09.01.2013	Quito	2h38'	MIDUVI Fundacion Bien Estar TUDelft MDMQ Corp. Responder * *Bogota	Round table: Social Management in affordable housing projects.
50UIO12	09.10.2012	Quito	1h10'	Felipe Bustamante	Operations Manager Housing Ecuadorian Bank (BEV)
51UIO12	09.10.2012	Quito	17'	Jenny Ruiz	Presidenta Asociación Mujeres Luchando por la Vida
52UIO12	09.10.2012	Quito	17'	Arq. Belen Garcia	MIDUVI Provincial office, Urban SIV
53UIO14	01.02.2014	Quito	36'	Alexandra Mina Evelyn Garcia	Presidents of board of homeowners, Alba Azul I and II
54BOG14	05.02.2014	Bogota	1h3'	Dr. Victor Ibarra	Asesor en Propiedad Horizontal
55BOG14	06.02.2014	Bogota	1h18'	Dra. Claudia Yopez	Curaduria No. 1
56BOG14	12.02.2014	Bogota	30'	Anyela Moreno	Horizontal Property Manager, El Cerezo
57BOG14	12.02.2014	Bogota	30'	Nayeri	Gerencia de Información Catastral Bogota
58BOG14	23.02.2014	Bogota	1h	Beatriz Hincapie	CUAN homeowner and long-time resident
59BOG14	24.02.2014	Bogota	51'	Arq. Maria Lucia Ortega	Planner and construction manager of Alameda del Parque
60BOG14	25.02.2014	Bogota	37'	Maria Mercedes Maldonado	Subsecretaria de Habitat y Vivienda. Alcaldia de Bogota.
61UIO14	05.03.2014	Quito	25'	Marianita Suarez	Community management and homeowner in Mz.16 Solidad Bicentenario
61UIO14	06.03.2014	Quito	24'	Alexandra Jaramillo	Social Management office, Municipal Housing corporation, MDMQ
63UIO14	10.03.2014	Quito	1h12'	Arq. Eduardo Castro	Eco&Arquitectos
64UIO14	29.03.2014	Quito	39'	Board of homeowners	Alba Azul I

Appendix B Survey Questionnaire

Questionnaire in Spanish, as applied in the field

ENCUESTA A HOGARES RESIDENTES EN PROYECTOS DE VIVIENDA EN BOGOTÁ Y QUITO

CIUDAD: BOGOTÁ QUITO

FORMULARIO No.

I. IDENTIFICACIÓN DEL ENTREVISTADO

- Nombre del conjunto residencial _____
- Identificación de la unidad habitacional en el conjunto (Bloque/Torre/etc.; No. Apartamento/Casa, etc.) _____
- Género del jefe de hogar (1) Hombre (2) Mujer
- Edad del jefe de hogar _____
- ¿Cuántos hogares habitan en la vivienda? _____
- Naturaleza del hogar (1) Principal (2) Secundario

II. ASPECTOS GENERALES

- ¿Desde cuándo ocupa el hogar esta vivienda? m i m a a a a a
- ¿Desde cuándo vive el hogar en este edificio o conjunto? m i m a a a a a
- ¿Qué tipo de vivienda ocupaba su hogar antes de esta unidad?

(1) <input type="checkbox"/> Casa en barrio	(4) <input type="checkbox"/> Apartamento en edificio / conjunto cerrado
(2) <input type="checkbox"/> Apartamento en barrio	(5) <input type="checkbox"/> Cuarto (s) integrado (s) a casa o apartamento
(3) <input type="checkbox"/> Casa en conjunto cerrado	(6) <input type="checkbox"/> Vivienda rural
- ¿Cuál era la forma de tenencia de su anterior vivienda?

(1) <input type="checkbox"/> Propia	(4) <input type="checkbox"/> Con permiso del propietario, sin pago alguno (usufructo)
(2) <input type="checkbox"/> Arriendo / subarriendo	(5) <input type="checkbox"/> Posesión sin título (ocupante de hecho)
(3) <input type="checkbox"/> Familiar	(6) <input type="checkbox"/> Otra forma
- ¿En general, como residente (propietario o arrendatario) de este edificio o conjunto, cómo califica su nivel de satisfacción?

(1) <input type="checkbox"/> Nada satisfecho	(2) <input type="checkbox"/> Satisfecho	(3) <input type="checkbox"/> Muy satisfecho
--	---	---
- El edificio o conjunto cuenta con:

1. <input type="checkbox"/> SI <input type="checkbox"/> NO <input type="checkbox"/> NS	Asamblea de copropietarios
2. <input type="checkbox"/> SI <input type="checkbox"/> NO <input type="checkbox"/> NS	Consejo de administración / Directiva
3. <input type="checkbox"/> SI <input type="checkbox"/> NO <input type="checkbox"/> NS	Administrador (a)

III. CARACTERÍSTICAS DE LA VIVIENDA

- ¿Cuántos cuartos tiene a disposición el hogar en la vivienda? (Incluye sala-comedor, excluye cocina, baño y garaje) _____
- ¿Cuánto tiempo se demora el jefe de hogar en su viaje de ida al trabajo? (Si el jefe de hogar no trabaja escriba NA: No aplica) _____

IV. MANTENIMIENTO DE LA PROPIEDAD COMÚN

- ¿Cómo califica la calidad constructiva de la vivienda? (carpintería, acabados, sistema constructivo)

(1) <input type="checkbox"/> Mala calidad	a. ¿En qué se manifiesta? _____	<input type="text"/>
	b. ¿Quién es responsable de esta mala calidad? _____	<input type="text"/>
(2) <input type="checkbox"/> Calidad regular	a. ¿En qué se manifiesta? _____	<input type="text"/>
	b. ¿Quién es responsable de esta calidad regular? _____	<input type="text"/>
(3) <input type="checkbox"/> Buena calidad		

25. (En caso de haber contestado NO a TODAS las opciones de la pregunta 23) Cuando los residentes hacen obras de acabados, cambios o remodelaciones, ¿se presentan conflictos entre vecinos a causa de ruido por la obra o daños causados?

- (1) Sí ¿Cómo califica los incidentes? (1) Serio o grave (2) Conflictivo (3) Sin trascendencia
 (2) No
 (3) No aplica (no se hacen cambios o remodelaciones)

26. ¿Quién(es) es(son) responsable(s) del mantenimiento del edificio o conjunto?

27. ¿Tiene alguna preocupación u observación en particular sobre el mantenimiento de las áreas comunes de su edificio o conjunto?

- (1) Sí ¿Cuál? _____ (2) No

V. TENENCIA COLECTIVA E INDIVIDUAL - PROPIETARIOS Y ARRENDATARIOS

28. Los parqueaderos en el edificio o conjunto son:

- (1) Comunales ¿Usted dispone de parqueadero exclusivo para su vehículo?
 (1) Sí ¿Cuánto paga mensualmente? \$ _____
 (2) No
 (3) No tiene vehículo

- (2) Privados ¿Usted dispone de parqueadero exclusivo para su vehículo?
 (1) Sí Este parqueadero es:
 (1) De su propiedad
 (2) Arrendado ¿Cuánto paga mensualmente de arriendo? \$ _____
 (2) No

29. ¿Ha recibido información sobre los derechos y obligaciones de ser propietario o arrendatario en conjunto o edificio? (1) Sí (2) No

30. ¿Ha oído nombrar la ley de propiedad horizontal?

(1) Sí a. ¿A quién o a quiénes ha oído hablar de la ley de propiedad horizontal?

- | | |
|---|---|
| 1. <input type="checkbox"/> 1.SI <input type="checkbox"/> 2.NO Vecinos en mi anterior lugar de residencia | 6. <input type="checkbox"/> 1.SI <input type="checkbox"/> 2.NO Presidente del Consejo de administración / Directiva |
| 2. <input type="checkbox"/> 1.SI <input type="checkbox"/> 2.NO Administrador provisional | 7. <input type="checkbox"/> 1.SI <input type="checkbox"/> 2.NO Alcaldía |
| 3. <input type="checkbox"/> 1.SI <input type="checkbox"/> 2.NO Vecinos actuales | 8. <input type="checkbox"/> 1.SI <input type="checkbox"/> 2.NO Medios de comunicación |
| 4. <input type="checkbox"/> 1.SI <input type="checkbox"/> 2.NO Administrador | 9. <input type="checkbox"/> 1.SI <input type="checkbox"/> 2.NO Auto - educación |
| 5. <input type="checkbox"/> 1.SI <input type="checkbox"/> 2.NO Constructor | 10. <input type="checkbox"/> 1.SI <input type="checkbox"/> 2.NO Otro. ¿Cuál? _____ |

b. ¿Qué tan informado se siente sobre lo que dice la ley de propiedad horizontal?

- (1) No sabe nada de lo que dice la ley (2) Medianamente informado (3) Conoce todo lo que dice la ley

(2) No

31. ¿Tiene interés por entender mejor lo que dice la ley de propiedad horizontal? (1) Sí (2) No

32. ¿Ha tenido la oportunidad de proponer la definición de alguna(s) regla(s) para la administración y mantenimiento del conjunto?

- (1) Sí (2) No

33. ¿En qué grado conoce a la mayoría de sus vecinos? (1) Nada (2) Poco / algo (3) Bastante

34. La vivienda que ocupa actualmente es:

(1) En arriendo o subarriendo

1. ¿Qué tan satisfecho se encuentra con el acuerdo de alquiler que actualmente tiene?

- (1) Nada satisfecho (2) Satisfecho (3) Muy satisfecho

2. ¿A cuánto asciende el pago mensual por concepto de arriendo? \$ _____

3. Tiene contrato de arrendamiento:

- (1) Escrito (2) Verbal (3) No tiene contrato

4. ¿Le gustaría adquirir una vivienda (casa o apartamento) en este conjunto o edificio? (1) Sí (2) No

5. ¿El dueño de la vivienda -o un delegado de la inmobiliaria en su representación- asiste a las reuniones de asamblea de propietarios?

- (1) Sí (2) No (3) No sabe

6. ¿Cuáles de las siguientes fuentes utilizó para el pago de su vivienda?

- | | | | |
|--|---|--|-------------------|
| 1. <input type="checkbox"/> 1.SI <input type="checkbox"/> 2.NO | Crédito de banco o corporación | 6. <input type="checkbox"/> 1.SI <input type="checkbox"/> 2.NO | Préstamo familiar |
| 2. <input type="checkbox"/> 1.SI <input type="checkbox"/> 2.NO | Crédito del Fondo Nacional de Ahorro, FNA | 7. <input type="checkbox"/> 1.SI <input type="checkbox"/> 2.NO | Venta de activos |
| 3. <input type="checkbox"/> 1.SI <input type="checkbox"/> 2.NO | Giros de residentes en el exterior | 8. <input type="checkbox"/> 1.SI <input type="checkbox"/> 2.NO | Ahorros |
| 4. <input type="checkbox"/> 1.SI <input type="checkbox"/> 2.NO | Crédito de una cooperativa o fondo de empleados | 9. <input type="checkbox"/> 1.SI <input type="checkbox"/> 2.NO | Otra. ¿Cuál? |
| 5. <input type="checkbox"/> 1.SI <input type="checkbox"/> 2.NO | Préstamo de la empresa | | |

34. La vivienda que ocupa actualmente es:(Continuación) Opción (2) Propia

7. En este momento la vivienda se encuentra:

- (1) Completamente pagada
- (2) En proceso de pago ¿A cuánto asciende la cuota mensual? \$ _____

8. Si quisiera vender en este momento su vivienda, ¿en cuánto la vendería? \$ _____

9. ¿Se encuentra al día con el pago del impuesto predial?

- (1) Sí
- (2) No ¿Cuál fue el último año que pagó impuesto predial? _____

10. ¿Cuánto pagó el último año por concepto de impuesto predial? \$ _____

11. ¿Quién le vendió esta vivienda? _____

12. En general, ¿qué tan satisfecho se sintió con el proceso de compra de la vivienda?

- (1) Nada satisfecho (2) Satisfecho (3) Muy satisfecho

13. ¿Cuál es su nivel de satisfacción frente a la suficiencia de información recibida durante el proceso de compra sobre los costos actuales de mantenimiento?

- (1) Nada satisfecho (2) Satisfecho (3) Muy satisfecho

14. ¿Cuándo se realizó la primera reunión donde conoció a sus vecinos y copropietarios?

- (1) Luego de firmar la promesa de compra-venta (4) No sabe
- (2) Tras ocupar la vivienda (5) Otra ¿Cuál? _____
- (3) No ha tenido lugar aún esta reunión

15. ¿Quién le brindó información concreta sobre los derechos y obligaciones de ser propietario de una vivienda en este edificio o conjunto?

- | | | | |
|--|--------------------------------------|--|---|
| 1. <input type="checkbox"/> 1.SI <input type="checkbox"/> 2.NO | Constructora | 5. <input type="checkbox"/> 1.SI <input type="checkbox"/> 2.NO | Miembros del Consejo de administración /Directiva |
| 2. <input type="checkbox"/> 1.SI <input type="checkbox"/> 2.NO | Administrador | 6. <input type="checkbox"/> 1.SI <input type="checkbox"/> 2.NO | Experiencia o iniciativa propia |
| 3. <input type="checkbox"/> 1.SI <input type="checkbox"/> 2.NO | Trabajador(a) social/Psicologo, etc. | 7. <input type="checkbox"/> 1.SI <input type="checkbox"/> 2.NO | Nadie informó |
| 4. <input type="checkbox"/> 1.SI <input type="checkbox"/> 2.NO | Vecino | 8. <input type="checkbox"/> 1.SI <input type="checkbox"/> 2.NO | Otro. ¿Cuál? |

16. ¿Quié(e)n tuvo(vieron) la iniciativa para organizar la reunión donde se conformó la primera directiva oficial del edificio o conjunto?

17. ¿Qué tan importante es tener reuniones de información sobre cómo administrar el mantenimiento de la propiedad colectiva antes de ocupar la vivienda?

- (1) Nada importante (2) Importante (3) Muy importante

18. ¿En su opinión, quién debería ser el responsable de compartir información sobre los derechos y obligaciones de los propietarios en el edificio o conjunto?

19. ¿Si requiere información o aclaración sobre el reglamento interno a quién se acercaría?

- | | | | |
|--|--------------------------------------|--|---|
| 1. <input type="checkbox"/> 1.SI <input type="checkbox"/> 2.NO | Constructora | 5. <input type="checkbox"/> 1.SI <input type="checkbox"/> 2.NO | Miembros del Consejo de administración /Directiva |
| 2. <input type="checkbox"/> 1.SI <input type="checkbox"/> 2.NO | Administrador | 6. <input type="checkbox"/> 1.SI <input type="checkbox"/> 2.NO | Medios de comunicación |
| 3. <input type="checkbox"/> 1.SI <input type="checkbox"/> 2.NO | Trabajador(a) social/Psicologo, etc. | 7. <input type="checkbox"/> 1.SI <input type="checkbox"/> 2.NO | No busco información |
| 4. <input type="checkbox"/> 1.SI <input type="checkbox"/> 2.NO | Vecino | 8. <input type="checkbox"/> 1.SI <input type="checkbox"/> 2.NO | Otro. ¿Cuál? |

VI. ADMINISTRACIÓN

35. ¿Cómo se financia el mantenimiento del edificio o conjunto?

(1) 1.SI 2.NO Cuotas mensuales (Si respondió afirmativamente, diligencie las preguntas a, b y c)

- a. ¿El dueño o usted está al día con la cuota mensual de mantenimiento? (1) Si (2) No
- b. ¿A cuánto asciende la cuota mensual de mantenimiento? \$ _____
- c. Qué pasa si se atrasa en el pago de la cuota mensual de mantenimiento por:

1. Se le da espera
2. Se le cobra un interés como multa
3. Se le abre un juicio
4. No pasa nada

a. Un mes		
1.SI	2.NO	3.NS
1.SI	2.NO	3.NS
1.SI	2.NO	3.NS
1.SI	2.NO	3.NS

b. Tres meses o más		
1.SI	2.NO	3.NS
1.SI	2.NO	3.NS
1.SI	2.NO	3.NS
1.SI	2.NO	3.NS

(2) 1.SI 2.NO Cuotas de acuerdo a proyectos

(3) 1.SI 2.NO Otra forma ¿Cuál? _____

36. ¿Conoce usted si algún vecino no está al día en sus pagos de mantenimiento?

(1) Si (2) No

37. ¿El edificio o conjunto tiene una cuenta bancaria común?

(1) Si (2) No (3) No sabe

38. ¿Cómo realiza o radica los pagos para el mantenimiento del edificio o conjunto?

- (1) Transferencia bancaria
- (2) Depósito en efectivo a la cuenta bancaria
- (3) Efectivo entregado a un miembro del Consejo de administración /Directiva
- (4) Efectivo entregado al administrador
- (5) Otra forma ¿Cuál? _____
- (6) No sabe

39. ¿Cuánta confianza tiene en que el dinero que se paga por la cuota de mantenimiento está bien administrada?

(1) Nada de confianza (2) Algo / poca confianza (3) Confianza total

40. ¿Tiene la asamblea de propietarios un fondo de reserva económico para emergencias o futuros gastos de mantenimiento?

(1) Si (2) No (3) No sabe

41. De acuerdo con su percepción, ¿con qué tanta honestidad el administrador trata los asuntos del edificio o conjunto?

(1) Nada de honestidad (2) Algo / poca honestidad (3) Total honestidad

42. Si tiene un problema con un vecino por asuntos relacionados con el mantenimiento de la propiedad común; ¿cómo solucionaría el conflicto?

1. 1.SI 2.NO Conversando directamente con el vecino
2. 1.SI 2.NO Busca a miembros del Consejo de administración / Directiva
3. 1.SI 2.NO Busca al administrador
4. 1.SI 2.NO Acude a un comité encargado de temas de convivencia
5. 1.SI 2.NO No se soluciona
6. 1.SI 2.NO Otra forma ¿Cuál? _____

VII. TOMA DE DECISIONES

43. ¿Hay obras que se realizan en áreas comunes SIN informar a los residentes del edificio o conjunto?

(1) Si (2) No

44. ¿Cuándo fue la última reunión de asamblea general de propietarios en este edificio o conjunto? m m a a a a a a
(en la que se eligió el Consejo de administración actual)

45. ¿Con qué frecuencia asiste usted a la reunión de propietarios?

(1) Nunca (2) A veces (3) Siempre (Pase a Preg. 47) (4) No asiste porque no es propietario (Pase a Preg. 47)

46. ¿Por qué no asiste SIEMPRE a la reunión de asamblea de propietarios?

1. 1.SI 2.NO Por el horario de trabajo
2. 1.SI 2.NO Lo considera una pérdida de tiempo (no se llega a nada en las reuniones)
3. 1.SI 2.NO No le interesan los temas que se discuten
4. 1.SI 2.NO Considera que su voto no es necesario
5. 1.SI 2.NO Otra razón ¿Cuál? _____

47. ¿Los arrendatarios asisten a las reuniones del edificio o conjunto?

(1) Si (2) No (3) No sabe

48. ¿Cuántas reuniones de residentes para la toma de decisiones hay al año en el edificio o conjunto?
49. ¿Se han realizado actividades donde todos aportan con trabajo comunitario para mantener el edificio o conjunto?
- (1) Sí a. ¿Qué tipo de actividades comunitarias se han desarrollado?

- b. ¿Participa usted en este tipo de actividades? (1) Sí (2) No
- (2) No
 (3) No sabe
50. ¿Ocupa usted algún cargo o posición en el Consejo de administración / Directiva actual?
- (1) Sí
 (2) No a. ¿Ha participado en momentos anteriores como parte del Consejo de administración / Directiva? (1) Sí (2) No
- b. ¿Cuál sería su interés en participar en el Consejo de administración / Directiva?
 (1) Ninguno (2) Algo / poco (3) Total interés
51. ¿Se postularía como administrador(a) del edificio o conjunto?
- (1) Sí ¿Por qué? _____
- (2) No ¿Por qué? _____
52. ¿Qué tanta confianza le inspira el Consejo de administración / Directiva actual? (1) Ninguna (2) Algo / poca (3) Total

53. Sobre los aspectos relacionados a continuación, indiquenos si se han tomado decisiones al respecto y en caso afirmativo, si se encuentra de acuerdo con las mismas:

a. Aspectos de convivencia

1. 1.SI 2.NO Tenencia de mascotas
2. 1.SI 2.NO Control de niveles de ruido
3. 1.SI 2.NO Hábitos para secado de ropas

b. Conformidad con las decisiones adoptadas

	(1) SI	(2) NO
1.	1.	1.
2.	2.	2.
3.	3.	3.

VIII. CARACTERÍSTICAS SOCIOECONÓMICAS DEL HOGAR

54. ¿Cuántas personas hay en total en la vivienda?
55. ¿Cuántas personas conforman su hogar?
56. Cuántos miembros del hogar tienen entre:
1. 0 y 10 años
2. 11 y 18 años
3. 19 y 34 años
4. 35 y 60 años
5. Más de 60 años
57. Actualmente el jefe de este hogar:
- (1) No está casado(a) y vive en pareja hace menos de dos años (4) Está separado(a) o divorciado(a)
- (2) No está casado(a) y vive en pareja hace dos años o más (5) Está soltero(a)
- (3) Está viudo(a) (6) Está casado(a)
58. ¿Cuál es el nivel educativo más alto alcanzado por el jefe de hogar?
- (1) Ninguno (5) Media (10 a 12)
- (2) Preescolar (6) Técnico o Tecnológico
- (3) Básica primaria (1o a 5o) (7) Universitaria
- (4) Básica secundaria (6o a 9o) (8) Posgrado

59. ¿En qué ciudad o municipio nació el jefe de hogar? _____

60. ¿Cuál es la situación laboral actual del jefe de hogar?

(1) Empleado

a. ¿Cuál es el tipo de empleo?

(1) Permanente

(2) Temporal

b. ¿Cuál es la ocupación, profesión, oficio, o clase de trabajo que desempeña?

c. ¿A qué actividad se dedica principalmente la empresa o establecimiento en el que realiza su trabajo?

d. En este trabajo es:

(1) Trabajador familiar sin remuneración

(4) Empleado doméstico

(2) Obrero o empleado particular

(5) Trabajador por cuenta propia

(3) Obrero o empleado del gobierno

(6) Patrón o empleador

(2) Desocupado

(3) Inactivo

61. ¿El jefe de hogar está cotizando actualmente a un fondo de pensiones?

(1) Sí

(2) No

62. ¿A cuánto asciende el ingreso básico mensual del jefe del hogar? (por concepto de trabajo) \$ _____

63. ¿A cuánto asciende el ingreso mensual del jefe del hogar por conceptos diferentes al trabajo? \$ _____

64. ¿Cuántas personas del hogar residentes en esta vivienda trabajan? (sin incluir el jefe del hogar) _____

65. ¿Cuánto suma el ingreso mensual de los otros miembros del hogar que trabajan, devengan ingresos derivados de otras actividades o reciben ayuda económica? \$ _____

66. Finalmente, escoja por favor una o más razones por las cuales usted considera que es posible organizarse entre propietarios y arrendatarios en este edificio o conjunto:

1. 1.SÍ 2.NO Porque todos son buenos vecinos

4. 1.SÍ 2.NO Porque hay una ley de propiedad horizontal

2. 1.SÍ 2.NO Porque hay un reglamento interno que todos siguen

5. 1.SÍ 2.NO No cree que se logre organización entre vecinos

3. 1.SÍ 2.NO Porque hay normas de convivencia que respetan

Encuestador: _____

Fecha

Appendix C Case studies in Bogota and Quito

Affordable condominiums selected in Bogota, Colombia

B01- Centro Urbano Antonio Nariño (CUAN)- 1958

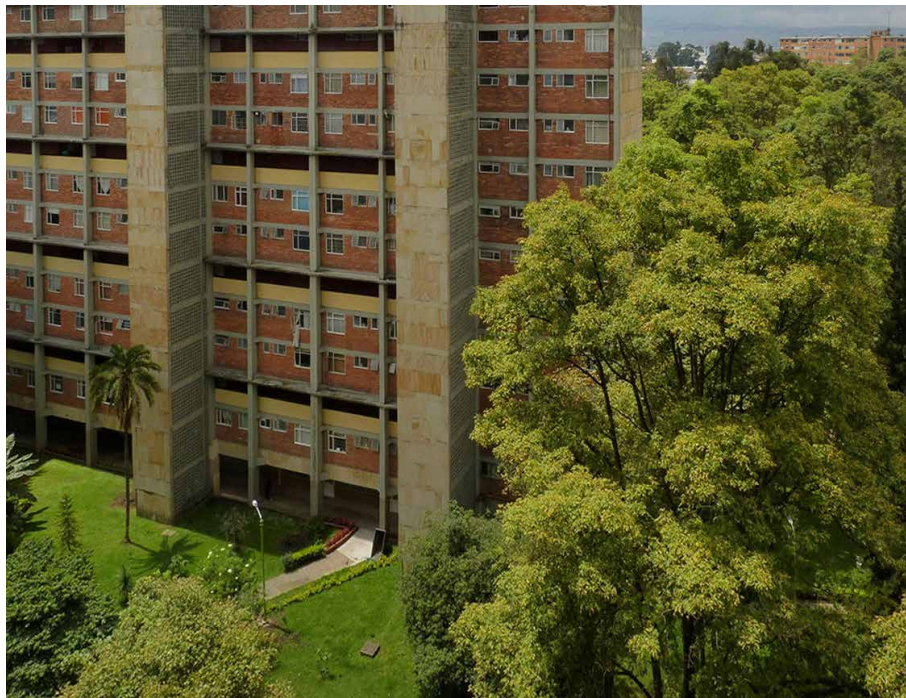
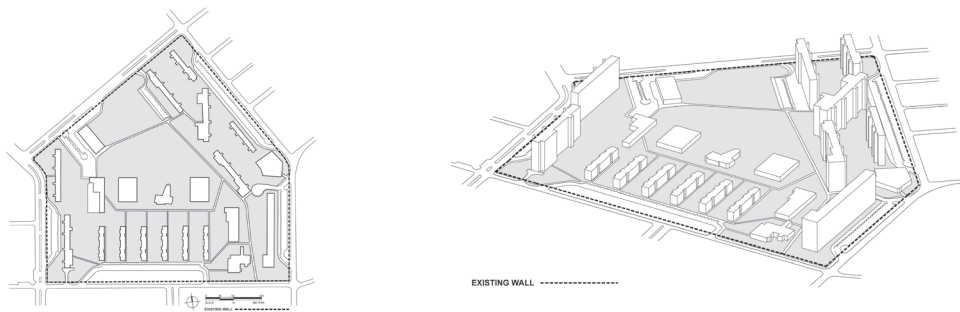


FIGURE APP.C.1 Urban Center Antonio Nariño (1958)(photo by author)

CUAN (1958) was the first high-density multi-family housing complex in the city of Bogota (Forero & Forero, 2009). It is the oldest of the selected cases in the research. Because of its physical characteristics, it has made a mark on the city and in housing policy. In the literature, it has received much attention as an example of modern housing architecture in Colombia, but little is known about how it is organized and managed in order to keep such a big estate in optimal condition. The construction was started in 1952 by the Ministry of Public Works of Colombia, but it was finished by the Popular Bank in 1958. The goal was to provide dwellings for low- and middle-income workers. This project was part of a series of housing programs for home ownership promoted by the state. The governmental housing organization, the Institute for Territorial Credit (*Instituto de Credito Territorial – ICT*), was involved in managing the selection, sales, and organization processes of the new community taking shape at CUAN. At that time, people who bought the units paid monthly installments directly to ICT. A group of social workers from ICT had been put in charge of both the selection process of families and the ‘induction process’ into multi-family living rights and obligations (Torres, 2013, personal interview).



1

2

FIGURE APP.C.2 Site plan Urban Center Antonio Nariño (by author)

In 2000, a general assembly meeting of co-owners unanimously approved a project that asked the ministry of culture to declare CUAN an estate of cultural importance for the country because of its architecture.⁶⁵ Having CUAN declared an estate

65

The association achieved its goal, and under the Ministerial Resolution 0965, CUAN received designation as an Estate of Cultural Interest of National Character in 2001. Resolution 0965 of 2001, found in the General Archive of the District Planning Department of the City of Bogota.

with architectural and cultural values was seen as a good strategy to address the deterioration process of the complex. Some co-owners had already begun to build on and occupy common areas, and the complex was at risk of losing its architectural value. However, more important than the protection of both the architectural value and the control of the use of common elements were the discounts in taxes and services that CUAN co-owners could gain if it were to be declared a residential monument.⁶⁶ A sense of pride comes to the surface in every conversation with the residents about the complex. The same year that CUAN was declared architectonic patrimony of the city, the new law of horizontal property (Law 675) was passed by the National Congress. Both events contributed to the 'new era of organization', as the president of the board of homeowners put it (personal interview, July 2011). In the same year, a new property manager was hired by the board. The new manager helped the board of owners get the complex into compliance with the new law of horizontal property and also worked to bring the association's bank account back to health without deficits.

The complex sits on an autonomous urban block of 14 hectares. It has 752 apartments distributed over eight towers or 'blocks', as they are called by the formal institutions such as the regulations, which is the statute of CUAN's horizontal property. Almost 70% of the land is open space.⁶⁷ Today, CUAN's grounds are fenced and have two guarded entrances that provide access to pedestrians and allow cars into parking lots. To enter the complex, people have to show an identification card provided by the management office or have a specific invitation from a resident. Inside the complex there is a theater (659 m²), a middle school (2427 m²), and a grocery store and other commercial spaces (1993 m²), all of which are part of the collective ownership in CUAN. Some of these buildings, such as the school grounds, theater, and commercial spaces, are rented out by the administration office of the complex. The theater is used for the annual general assembly meeting of co-owners, and it was recently renovated in 2013.

The association of co-owners, ASOCUAN, was formed back in the 1960s through the initiative of a group of residents who saw the need to have co-owner representation in order to organize the management of the residential complex while ICT was still allocating apartments to new owners. The association registered a juridical person

66 Minutes of the Ordinary Assembly Meeting of co-owners of the Urban Center Antonio Nariño (CUAN). Teatro Cadiz, Bogota. August 12, 2000.

67 Including parking lots. Gross residential density would be 49 units per hectare. Net residential density is 152 units per hectare.

later in 1977, but the position was updated and registered again in 1990.⁶⁸ Today, the role of the juridical person is assumed by the hired property manager, according to the Horizontal Property Law 675 of 2001.

The management and maintenance plan and the budgets are available in the office of the property manager, located in the same complex, and are also accessible from their website. Each plan is drawn up for five years, and the latest one extended until 2015 (At least during the period of investigation). This plan has three main components: (1) recuperation of the patrimonial value of the estate; (2) co-residence and community participation; and (3) organization of administration and finance processes.⁶⁹

Income sources are mainly the administration fee charged to each unit and rental income from the resident parking space (57% of income).⁷⁰ The rest of the budget comes from other sources in the common property such as the rents from commercial spaces, apartments owned by the association, parking for visitors, and the lease of common rooms, the football field, the theater, and other common spaces (40% of income). In total, CUAN's administration office manages an annual income of almost a million dollars. Expenses and costs of services (53%), maintenance and repairs (32%), salaries for personnel (4.4%), insurance, and other expenses, such as community events for Christmas or Mother's Day, run about a million dollars annually. Services include the subcontracting of security (private guards) and cleaning companies.

68 CUAN, 2005. Finance Report, 2005. Accessed at: www.asocuan.org, July, 2012.

69 CUAN, 2011. Quinquennial Plan 2011-2015. Accessed at: www.asocuan.org, July 2014.

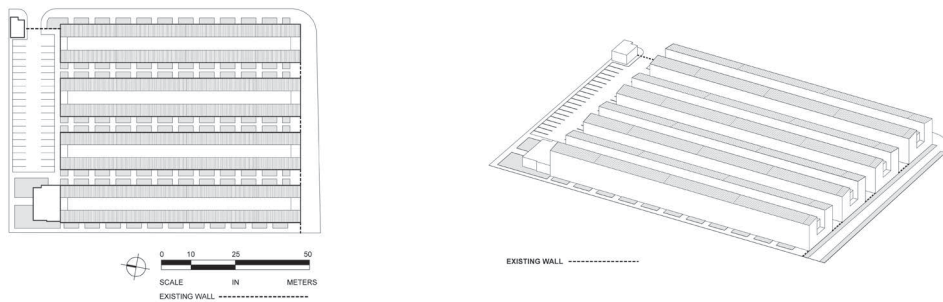
70 Budget execution report, 2012 Accessed at: www.asocuan.org, July 2014.

B02 - Alameda del Parque VIII– 2003



FIGURE APP.C.3 Alameda del Parque VIII (photo by author)

Alameda del Parque is an extensive development consisting of multiple complexes, all of which were constructed by the same private developer in Bosa, Bogotá. It was built in phases, and only one complex (Phase VIII), which was finished in 2003, was selected for the study. Due to the problems among community members in this housing complex, the builder, by recommendation of the project manager, hired a social manager to help with the social issues seen among the new community of homeowners. Some of the complexes were still in the process of sales or construction, so the builder invested in social management for the first time. After this experience, the social management corporation became an ally of the developer in facilitating the current and prospective owners' understanding of the rights and obligations of homeowners and helping with community organization.



1

2

FIGURE APP.C.4 Site plan, Alameda del Parque VIII (by author)

For the builder, *Alameda del Parque* was the first affordable housing project in its portfolio. The goal was to develop a market-based housing complex, and the key product was a single-family house (row-house), which proved to be very successful during the sales stage. Until then, as the former project manager of the project mentioned, the affordable housing options in the market were only apartments, and the builder's goal was to meet the demand for single-family houses. Additionally, these houses were developed in a condominium regime as a way to ensure some regulatory regime that would help conserve the 'order' of the complexes.

Social managers began with a social assessment in order to design their path of action.⁷¹ From the assessment, they learned about some of the issues that were causing co-residence problems among the new homeowners. The perceived problems were related to issues such as lack of control and access to the common property, condition of green areas and playgrounds, and lack of property management. They also identified other social problems, such as domestic violence, youth gangs, insecurity, and noise, as conditions that were heightening the level of social conflict already present in the community.

As community facilitators, social managers organized events so that the new neighbors could meet each other. They also identified individuals who could serve as leaders of the community and helped some of them with scholarships to receive training in horizontal property administration. They organized community days during which everyone was encouraged to fix up the little yards in front of their dwellings. Moreover, social managers helped the developers realize that the way they had designed the

71

The report that I had access to is dated April 29, 2008, "Socioeconomic Assessment and Social Management Plan," (In Spanish) prepared by CTA-Management and Development of Human Resources for Constructora Amarillo S.A.

complexes was creating problems, too. Specifically, the boundaries of the properties were not clearly defined.

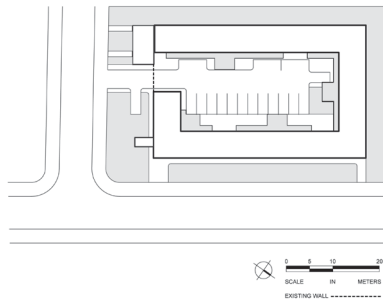
The parking lot, as in many other affordable housing projects, is communal because parking spaces are not included in the price of an individual unit. Communal parking lots generate income through rents. The problem is, how should the income be used if it is not known who the clear owner of each parking space is? As the social manager and later the property administrator mentioned in interviews, the parking lot became a disputed space. Reorganization of parking spaces to allow motorcycle and bicycle storage was necessary. Others in the community would have preferred the reorganization to include more playgrounds for children. To better distinguish the clusters of houses and borders of the common property, the facades of the complex were painted different colors, which also set off smaller areas for management purposes.

Currently, social managers are not present in this community. The property manager at the time of research was an owner of a unit in the housing complex who has received training in horizontal property management. Under his administration of the housing complex, people have started to free-ride on others. Not everyone pays the maintenance fee according to the management and maintenance plan. Additionally, some people have already built extensions on their living rooms reaching toward the common areas (see pictures) without following the formal procedures defined in the law.

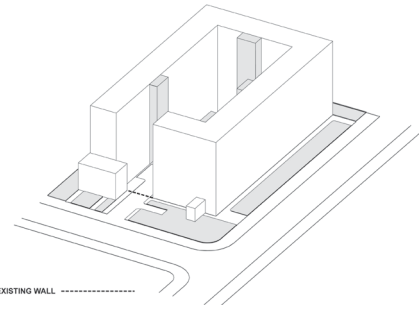


FIGURE APP.C.5 El Cerezo building. (photo by author)

El Cerezo is an affordable housing project located in USME, one of the southern land development areas of the city of Bogota set aside to provide affordable housing. The developer, the owner of a centrally located piece of land in USME, subcontracted both the architectural design and construction of the project. The sales and the accompanying subsidy application processes were carried out by the developer's sales department. The developer had a small sales office in one of the commercial spaces in the building. During the first phase of sales, the developer paid for a security service and for maintenance of the building. This changed once 51% of the units had been sold, at which point, in accordance with the law, the initial owner (the developer) had to pass on responsibility for management and maintenance to the new community of owners by calling an assembly meeting and electing a board of co-owners.



1



2

FIGURE APP.C.6 Site plan, El Cerezo (by author)

The developer did not hire a social manager to help with the transition (in contrast to the *Alameda del Parque* case). Instead, the developer sent a letter to all current new owners, and a new board assumed the responsibility for the newly established community of homeowners. A month later the new board called the first assembly of owners in order to establish the fees for maintenance and to discuss the options to hire a property manager. As a researcher I was able to attend this meeting (July 2011), which was held on a Saturday afternoon and lasted about four hours.

Some apartments and commercial spaces in the existing building were still for sale at the time. Therefore, the developer was still the owner of these units, which also made it a co-owner in the community. Although the developer was a co-owner, it did not attend or send a representative to the first homeowners' meeting. The meeting was planned by the new board, which involved inviting someone to explain the horizontal property law and presenting two candidates for the role of property manager of the community. The first part of the meeting was dedicated to providing information about the condominium regime, especially the obligation to hire a property manager and security services and to purchase earthquake insurance for the common property. During the second part, the candidates for the position of property manager role introduced themselves and outlined their costs. The community of homeowners then voted and elected one of them.

Once the new property manager had been appointed, the board members presented the budget for administration and maintenance of the building. All these costs, together with other normal expenses, would put the maintenance fee at about 60,000 Colombian pesos. The president of the board wrote these amounts on a whiteboard. Attendance at the meeting was high when it started; the room was full, with people standing and no more chairs. By the end, partly as a sign of dissent, many people had left, so when 70% of all co-owners were needed to approve a budget, there

were not enough owners present to vote. Therefore, the budget was not approved in the first assembly. The board had to call a second assembly meeting. The property manager started out in a property with a community that was already unhappy about the construction quality of the building and its maintenance fees. This was how the organization of the community of owners got started at El Cerezo.

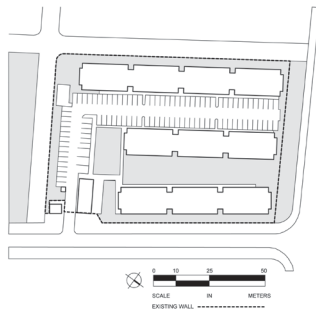
At the time of investigation, three years after the first assembly meeting at El Cerezo, common property was still organized under the supervision of a working board and a property manager. However, maintenance fees are high and problems with construction quality have led to a legal battle between the community of owners, with the property manager serving as their legal representative, and the developer. To generate income, the board leases the community meeting room for diverse activities and also leases the parking spaces, even though there are not enough spaces for all the apartments and the parking lot was designed for common use. Regarding security services (door guards), they decided to keep the role informal, so they hired two people to work as security guards. According to the current property manager, no security company is involved; formal contracts are too expensive and the condominium administration cannot afford them.

B04- Victoria II – Ciudad Verde – 2012



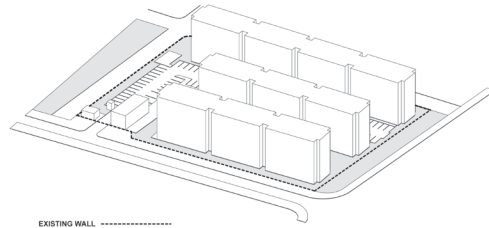
FIGURE APP.C.7 Victoria II building (photo by author)

Victoria II is one of the many condominium housing complexes built in Ciudad Verde on the periphery of Bogota. Technically, the site lies in Soacha Municipality, which could provide many public services. Nonetheless, for now the builder is assuming many of these costs in order to encourage sales in one of the biggest housing development projects in Colombia. The builder maintains the public spaces. Every block (*manzana*) consists of one housing complex in common property. Victoria II, was built by the development company *Constructora Bolivar*. This builder currently has a department called 'social capital', which is in charge of social management during the provision phases.



1

FIGURE APP.C.8 Site plan, Victoria II (by author)



2

By the time the household survey for this thesis was complete, the community of Victoria II, which had only been in existence for two years, had already received the Builder’s Prize for the best-organized condominium. The developer holds competitions and awards prizes to those projects that have demonstrated good management and maintenance paths. In this way, the developer maintains its relationship with the community of owners, offering advice about any management or maintenance issue.

The current property manager of the condominium is also a co-owner in the community. He is a professional property manager; not only did he study administration but he also took other courses and trained to learn about the specifics of horizontal property management. As he mentioned during the interview, to manage a building it is necessary to know about psychology and also how to manage money.

Affordable condominiums selected in Quito, Ecuador

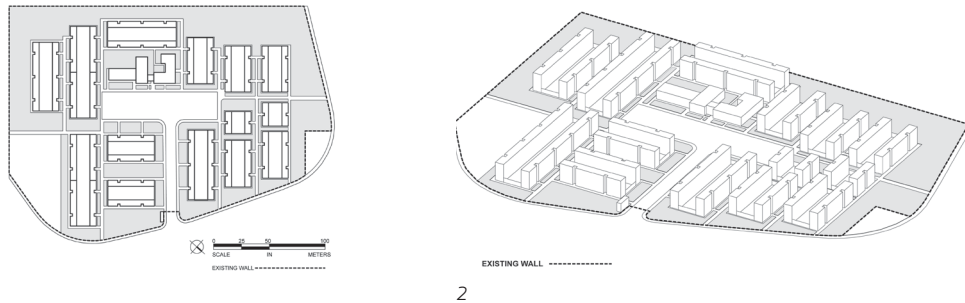
Q01 - Condominios Luluncoto- 1974



FIGURE APP.C.9 Luluncoto condominium complex (photo by author)

Luluncoto condominium was built in 1974 by the government housing institutions of the time, which were BEV (Ecuadorian Housing Bank) together with JNV (National Housing Council). The common property in condominium comprises 480 apartments,

and it takes its name from the neighborhood in which it is located.⁷² The layout of the housing complex follows the principles advanced by the Conference for International Modern Architecture (CIAM) for architecture and mass housing provision. The five-story blocks are arranged in such a way that each has ten apartments with a shared entrance door and stairways. Today the premises are surrounded by a wall, which was built through the homeowners' efforts. The wall includes a guarded entrance to control access in general but more specifically the access to the parking lot. The pedestrian entrance that faces the principal street is currently not guarded.



1
2
FIGURE APP.C.10 Site plan, Luluncoto condominium complex (by author)

The parking area is communal. There are no individual parking spaces for all 480 apartments, and parking spaces were not sold to homeowners in the 1970s. Therefore, much of the organizational effort is focused on institutional arrangements to share the use of the parking lot among those residents who own vehicles. The working board of homeowners designates a manager to organize the parking space and collect the rent. The salary of the guard for the parking lot comes out of the rental revenues. According to the interview with the manager at the time, there is no money left to maintain the parking surface and asphalt. Owner-occupiers pay a different price for a parking space than tenants in the complex.⁷³ Spaces become available to others to use or rent when someone defaults on rent payments.

72 Four housing blocks are legally part of the common property, but they are separated by an additional wall. These dwellings are owned by the workers of the aviation national army. In terms of governance and management, these dwellings are not considered in the analysis of Luluncoto (Q01).

73 The price for tenants is ten dollars higher.

This housing complex is similar to CUAN (B01) in the sense that common property resources are used to generate income. The parking lot is one example. The housing complex also has other buildings that belong to the common property, and those are leased to generate income. There is a small market on the premises as well as small buildings with service functions located in the original entrances. From the 1970s until the end of the 1980s, there was a big grocery store inside (EMPROVIT), a publicly owned enterprise. When the store closed, the building was sold to a Christian church. This church is now a co-owner, together with the owners of the 480 apartments. There is a big community house on the common property, which is leased for parties and other events organized by the residents. This is also where the general assembly of homeowners is held every year.

There is a board of homeowners, but the organization of Luluncoto condominiums is informal. No legal representative of the common property is registered in the property registry office, although this is mandated by the Ecuadorian horizontal property law. The common property does not have a bank account. Maintenance of buildings is done by blocks and by agreement among those apartments that share a common entrance. The agreement for each tower is different, with some units paying about two dollars to ensure cleaning of the stairways. When it is decided to repaint the facades, for example, a special fee is agreed upon and collected from owners in the block. Agreement per project is more common than planned maintenance.

The pictures of the complex clearly show some small units on the roof terraces that have been built by the owners. Similar structures have also been built on the grounds of each tower in the backyards. These small units, called 'minis' by the community, can be either an extra bedroom for a family, a studio type of unit, or a covered laundry area. Both the roof terraces and the backyards are legally designated as common property. These common spaces were originally divided by the builder into squares using metal screens. Each space was then assigned to a corresponding apartment for the residents' exclusive and private use. The purpose was to create individual and secure spaces to hang laundry.

Over time people started to replace the screens with concrete block walls, both on the roof terraces and in the backyards.⁷⁴ Owners apparently understood 'exclusive and private use of a common area' to mean the same as use of individual property. At some point, the municipality came into action, since no building permits had been issued to make these units legal according to city regulations. The concern was mostly about

those units built on the roof terrace because the building was designed for a certain load bearing structure, and those units could put the building at risk.

These 'minis' serve various purposes; they can be small apartments for rent, apartments where grandmothers live, or laundry areas. Units built on the ground floor are basically now extensions of the apartments on the first and second story. Informally, these additions are now the norm, since general agreement has been reached among co-owners about their encroachment on common property areas. However, some apartments are now bigger because of these extensions. Moreover, these modifications are not included in the condominium regulations, and therefore they are not covered in the property titles.

Q02- Vivienda Solidaria, CHQ – 2003

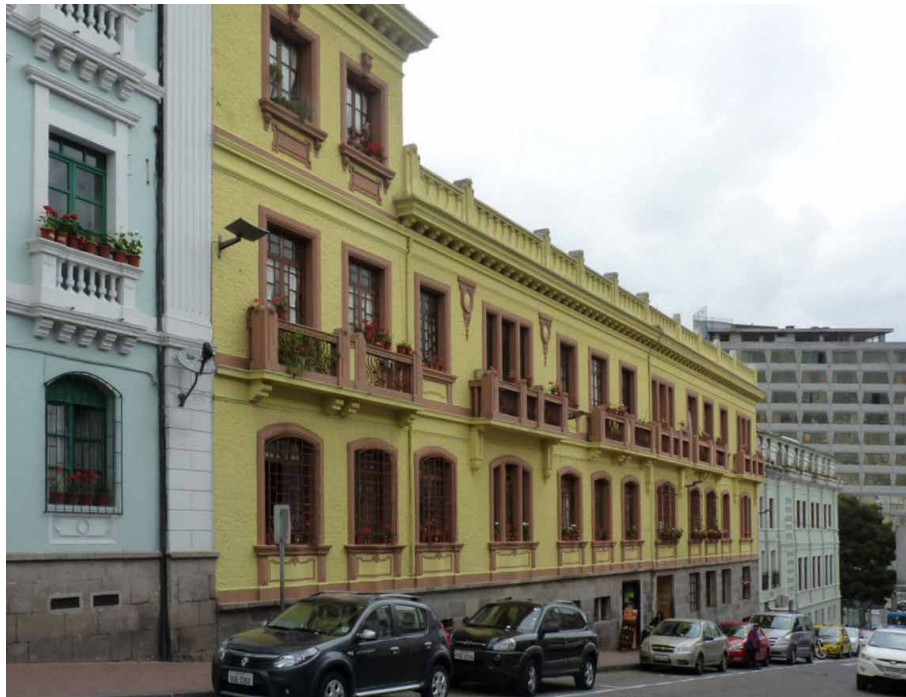
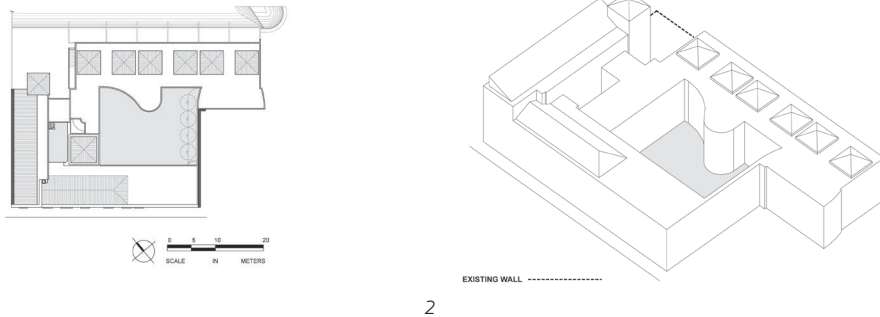


FIGURE APP.C.11 Caldas 494, *Vivienda Solidaria* Program, Historic Center of Quito (2012) (photo by author)

The *Vivienda Solidaria* program was implemented in Quito from 1997 until 2003 (Donoso, 2008). This small housing program was part of an urban renewal project to improve urban and housing conditions in the historic center. It started with ten single-family houses that were at the time tenements where very low-income families were living. The properties were bought by the municipality and transformed into small condominiums for low-income homeownership. For the construction and rehabilitation of the buildings, the tenants were rehoused in other municipally owned buildings. Some of them were able to come back as homeowners after receiving a down-payment subsidy for their mortgages. Some of the more expensive units in each property were sold to families that were not eligible for the subsidy. In this way, the program created mixed-income communities in condominium tenure. All homeowners had to pass a selection procedure established by the municipal corporation for the rehabilitation of the historic center. The main condition to become an owner in this project was to prove previous residency in the historic center of Quito (Donoso, 2008).

For a survey of some of the households in these centrally located condominiums, I selected four properties. I chose those condominium complexes where I was able to ask the homeowners' association for permission to enter the premises. There are some complexes without a working homeowners' board, which makes it more difficult to distribute flyers and to survey the residents.



1 2
 FIGURE APP.C.12 Site plan, Caldas 494. *Vivienda Solidaria* Program (by author)

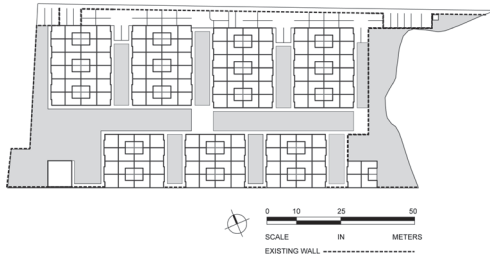
The properties that were converted into condominiums vary in size in terms of number of individual dwellings inside. The smallest has six units and the biggest has 54. Because of the location and size of the lots, these buildings do not have parking garages. Renovation of historic buildings allows major transformation inside the

structure. The facades and the configuration around a central patio are architectural elements that are protected for their historical value.⁷⁵ Every building has a patio instead of an open garden, as other condominiums generally have. Patios, however, require a different kind of maintenance than gardens. Therefore, even though these dwellings do not have a green open space, the patios become common spaces that require collective maintenance, as do the historic facades.

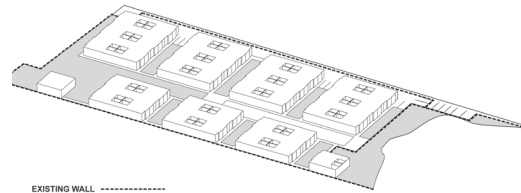
Q03- Alba Azul I & II – 2010



FIGURE APP.C.13 Alba Azul condominium complex (2012) (photo by author)



1



2

FIGURE APP.C.14 Site plan, Alba Azul condominium complex (2012) (by author).

Alba Azul I and II are two projects built through the collaboration of many actors, among which are a women’s organization, a housing and research foundation, and a housing developer. The women’s organization applied for a housing subsidy and found a developer that helped it find a piece of land to build the dwellings. Since the organization was poor, the banking system did not give it any mortgage; therefore they collaborated with the housing and research foundation. The foundation had a working program called “Paso a Paso” (Step by Step), which provided assistance in building and paying for the homes. Basically, the foundation became the lender and coordinator for the development of the housing project.

The leader of the women’s group was in charge of the individual subsidy applications. Each family applied individually, but the leader dealt with all the paperwork for 100 families. In the meantime, the developer found the land and started to design the project. Future homeowners, including the women’s group, were not asked to comment or get involved during the design phases.

The future homeowners attended several informative sessions that were held at the foundation’s office. In a sense, they started to build the community even before they moved into the finished dwellings. The lead person, who took charge of the work and subsidy application process together with the titling process, is now the president of the board of homeowners. She also performs the role of property manager.

According to the president of the board of homeowners, a monthly maintenance fee does not work in this community. Although the board has a bank account, people do not deposit their maintenance fees in it. The residents would rather make contributions depending on the project. Sometimes they do community work but, as the leaders mentioned, not everyone comes to community events. For example, the lawn of the common gardens is mown every two or three weeks. Depending on the funds available, they will either hire someone to mow or the community will do it. The housing complex

is fairly new; although it was just finished in 2010, the pictures already show the need for facade maintenance.

Q04- Ciudad Bicentenario, Blocks 7, 9, and 16 – 2012



FIGURE APP.C.15 Ciudad Bicentenario (2014) (photo by author)

Ciudad Bicentenario is a land development project promoted by the Municipality of Quito. The infrastructure costs are assumed by the municipality. Different private and nonprofit developers and cooperatives in association with the municipality can build housing complexes in this area. For the survey, three blocks of the development were selected. Each block had a different builder, but in all cases some social management was involved during the housing provision process. Once Ciudad Bicentenario was chosen as a case, a selection was made among the housing blocks within it for the

survey. They were selected depending on whether access to the premises was granted by the board of homeowners at the time.

According to the law of horizontal property in Ecuador, there is no obligation to hire an external property manager. And indeed, these housing complexes do not have an external property manager; the role is performed by the president of the board, who also acts as the legal representative of the community. Owners were invited to several workshops as part of the social management initiatives of the municipality to ensure better outcomes from the program. One of the effects is a sense of pride in the communities about their dwellings. Also, the existence of a bank account and the registration of a legal representative of the condominium gives an indication that more information is available and that there is greater decision-making capacity within the community.

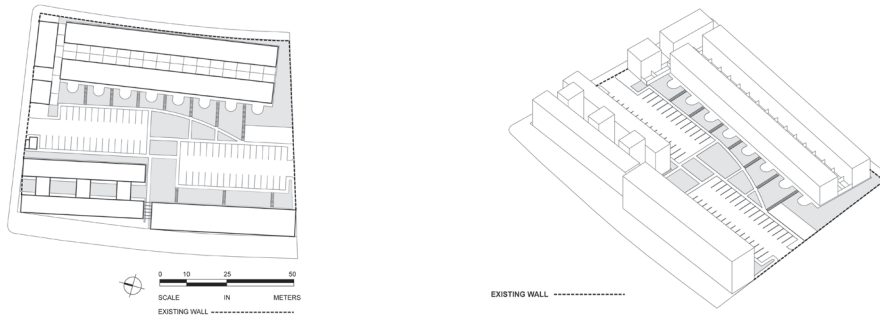


FIGURE APP.C.16 Site plan, Block 16, Ciudad Bicentenario (by author)

References

- Acosta, M. E. (2009). La gestión de la vivienda social en el Ecuador: entre la espada y la pared Ecuador Debate, 76, 93-106.
- Agrawal, A. (2001). Common Property Institutions and Sustainable Governance of Resources World Development, 29(10), 1649-1672.
- Alterman, R. (2010). The Maintenance of Residential Towers in Condominium Tenure: A comparative Analysis of Two Extremes - Israel and Florida. In S. Blandy, A. Dupuis, & J. Dixon (Eds.), Multi-owned housing: law, power and practice (pp. 73-90). Surrey: Ashgate Publishing Limited.
- Alzate, M. C. (2006). La estratificación socioeconómica para el cobro de los servicios públicos domiciliarios en Colombia. Solidaridad o focalización? Retrieved from Bogotá:
- Arbelaez, M. A., Camacho, C., & Fajardo, J. (2011). Low-income Housing Finance in Colombia. Retrieved from Washington D.C. :
- Ardilla Gomez, A. (1997). The Decentralization of the Government of Bogotá: Benefits, Problems and Possible Solutions (Master in City Planning), Massachusetts Institute of Technology, Cambridge, MA. Retrieved from <http://dspace.mit.edu/bitstream/handle/1721.1/63212/37788363-MIT.pdf?sequence=2>
- Assche, K. V., Beunen, R., & Duineveld, M. (2014). Evolutionary Governance Theory. An Introduction Heidelberg: Springer.
- Axelrod, R. (1981). The Emergence of Cooperation among Egoists. The American Political Science Review, 75(2), 306-318. doi:10.2307/1961366
- Balchin, P., & Stewart, J. (2001). Social housing in Latin America: Opportunities for affordability in a region of housing need. Journal of Housing and the Built Environment, 16(3-4), 333-341. doi:10.1023/A:1012520013862
- Baldwin, R. (1990). Why Rules Don't Work. The Modern Law Review, 53(3), 321-337.
- Baldwin, R., & Cave, M. (1999). Understanding Regulation. Theory, Strategy and Practice. Oxford: Oxford University Press.
- Ball, M., & Harloe, M. (1992). Rhetorical barriers to understanding housing provision: What the 'provision thesis' is and is not Housing Studies, 7(1), 3-15.
- Ballen, S. (2009). Vivienda social en altura. Tipologías Urbanas y directrices de producción en Bogotá Bogotá: Universidad Nacional de Colombia
- Barlow, J., & Duncan, S. (1988). The use and abuse of housing tenure. Housing Studies, 3(4), 219-231. doi:10.1080/02673038808720632
- Bengtsson, B. (1998). Tenant's Dilemma - On Collective Action in Housing. Housing Studies, 13(1), 99-120.
- Bengtsson, B. (2012). Game Theory. In S. J. Smith (Ed.), International Encyclopedia of Housing and Home (Vol. 2, pp. 227-231). Amsterdam: Elsevier.
- Bengtsson, B. (2012). Housing Politics and Political Science. In D. F. Clapham, W. A. V. Clark, & K. Gibb (Eds.), The SAGE Handbook of Housing. London: SAGE Publications Ltd.
- Bengtsson, B., & Hertting, N. (2014). Generalization by Mechanism. Thin rationality and Ideal-type Analysis in Case Study Research. Philosophy of the Social Sciences, 44(6), 707-732.
- Bengtsson, B., & Ruonavaara, H. (2010). Introduction to the Special Issue: Path Dependence in Housing. Housing, Theory and Society, 27(3), 193-203.
- Bengtsson, B., & Ruonavaara, H. (2011). Comparative Process Tracing in Housing Studies. International Journal of Housing Policy, 11(4), 395-414. doi:10.1080/14616718.2011.626603
- Bennett, D. S. (2011). Condominium Homeownership in the United States: Selected Annotated Bibliography of Legal Sources Law Library Journal, 103(2), 2011-2016. Retrieved from <http://www.aallnet.org/mm/Publications/llj/llj-Archives/Vol-103/Spring-2011/2011-16.pdf>
- Black, J. (2002). Critical Reflections on Regulation. Retrieved from London:
- Blanco, A. G., Cibils, V. F., & Muñoz, A. F. (2014). Rental Housing Wanted, Policy Options for Latin America and the Caribbean Retrieved from Washington D.C.:
- Blandy, S., Dupuis, A., & Dixon, J. (Eds.). (2010). Multi-owned housing: law, power and practice Surrey: Ashgate Publishing Limited.

- Blandy, S., Dixon, J., & Dupuis, A. (2006). Theorising Power Relationships in Multi-owned Residential Developments: Unpacking the Bundle of Rights. *Urban Studies*, 43(13), 2365-2383. doi:10.1080/00420980600970656
- Blandy, S., & Goodchild, B. (1999). From Tenure to Rights: Conceptualizing the Changing Focus of Housing Law in England. *Housing, Theory and Society*, 16(1), 31-42. doi:10.1080/14036099950150071
- Blandy, S., & Hunter, C. (2012). Socio-legal Perspectives. In S. J. Smith (Ed.), *International Encyclopedia of Housing and Home* (First Edition ed., Vol. 6). Amsterdam: Elsevier.
- Boelhouwer, P., & van der Heijden, H. (1993a). Housing policy in seven European countries: The role of politics in housing. *Netherlands journal of housing and the built environment*, 8(4), 383-404. doi:10.1007/bf02496562
- Boelhouwer, P., & van der Heijden, H. (1993b). Methodological trends in international comparative housing research. *Netherlands journal of housing and the built environment*, 8(4), 371-382. doi:10.1007/bf02496561
- Brannen, J. (2005). Mixing Methods: The Entry of Qualitative and Quantitative Approaches into the Research Process. *International Journal of Social Research Methodology*, 8(3), 173-184.
- Bromley, R. (2003). Peru 1957-1977: How time and place influenced John Turner's ideas on housing policy. *Habitat International*, 27(2), 271-292. doi:http://dx.doi.org/10.1016/S0197-3975(02)00049-8
- Bueren, E. v., & Heuvelhof, E. t. (2005). Improving governance arrangements in support of sustainable cities. *Environment and Planning B: Planning and Design*, 32, 47-66.
- CAMACOL. (2012). Subsidios Plenos y La Nueva Ley de vivienda y Desarrollo Urbano. Bogota. Retrieved from http://camacol.co/sites/default/files/secciones_internas/Informe%20Econ%C3%B3mico-Julio-No%2038_0.pdf
- Cárdenas, J. C. (2009). Dilemas de lo colectivo: instituciones, pobreza y cooperación en el manejo local de los recursos de uso común. Bogota: Universidad de Los Andes, Facultad de Economía, CEDE, Ediciones Uniandes.
- Castles, F. G., & Ferrera, M. (1996). Home Ownership and the Welfare State: Is Southern Europe Different? *South European Society and Politics*, 1(2), 163-185. doi:10.1080/13608749608539470
- Chen, S. C. Y. (2011). Common Interest Development and the Changing Roles of Government and Market in Planning. *Urban Studies*, 48(16), 3599-3612. doi:10.1177/0042098010394687
- Chen, S. C. Y., & Webster, C. J. (2005). Homeowners Associations, Collective Action and the Costs of Private Governance. *Housing Studies*, 20(2), 205-220. doi:10.1080/0267303042000331736
- Choe, J. (1992). The organization of urban common-property institutions: the case of apartment communities in Seoul. (Doctor of Philosophy), Indiana University Bloomington.
- Chu, F.-N., Chang, C.-O., & Sing, T. F. (2012). Collective action dilemmas in condominium management. *Urban Studies*, 50(1), 128-147.
- Colombia, C. d. l. R. d. (2004). Pasado, presente y futuro de las Cajas de Compensación Familiar. Bogota Retrieved from <ftp://ftp.camara.gov.co/uatl/eal/041%20CAJAS%20DE%20COMPEN-SACI%C3%83%E2%80%9CN%20FAMILIAR%20EN%20COLOMBIA.pdf>.
- Cribbet, J. E. (1963). Condominium, Home Ownership of Megalopolis? . *Michigan Law Review*, 61, 1207-1244.
- Dawes, R. M., & Messick, D. M. (2000). Social Dilemmas. *International Journal of Psychology*, 35(2), 111-116. doi:10.1080/002075900399402
- Demsetz, H. (1967). Toward a Theory of Property Rights. *The American Economic Review*, 57(2), 347-359. doi:10.2307/1821637
- DiMaggio, P. J., & Powell, W. W. (1983). The Iron Cage Revisited: Institutional Isomorphism and Collective Rationality in Organizational Fields. *American Sociological Review*, 48(2), 147-160. doi:10.2307/2095101
- Doling, J. (1997). *Comparative Housing Policy : Government and Housig in Advanced Industrialized Countries* New York: St. Martin's Press.
- Doling, J. & Elsinga, M. (2013). *Demographic change and Housing Wealth: Homeowners, Pensions and Asset-Based Welfare in Europe*. Dordrecht: Springer.
- Doling, J., & Ronald, R. (2010). Home ownership and asset-based welfare. *Journal of Housing and the Built Environment*, 25(2), 165-173.
- Donoso, R. E. (2008). A Case Study of Housing Programs in the Historic Center of Quito: The Need for Planning Direction (1990-2007). (MSc. in Community and Regional Planning), The University of Texas Austin.
- Donoso, R. E. & Elsinga, M. (2016). *Housing in Latin America and the Caribbean* In K. B. Anacker, A. Carswell, Sarah D. Kirby, & K. T. Tremblay. (Eds.), *Introduction to Housing*. Athens, GA: University of Georgia Press.

- Earl, P. E., & Potts, J. (2011). A Nobel Prize for Governance and Institutions: Oliver Williamson and Elinor Ostrom. *Review of Political Economy*, 23(1), 1-24. doi:10.1080/09538259.2011.526291
- Edelman, L. & Suchman, M. (1997). The Legal Environments of Organizations. *Annual Review of Sociology*, 23, 479-515.
- Elsinga, De Decker, P., Teller, N., & Toussaint, J. (Eds.). (2007). Home ownership Beyond asset and security. Perceptions of housing related security and insecurity in eight European countries. Amsterdam: IOS Press.
- Elsinga, M. (1998). The meaning of tenure under different conditions; empirical evidence from the Netherlands. *Netherlands journal of housing and the built environment*, 13(2), 137-155. doi:10.1007/bf02497226
- Elsinga, M. (2005). Affordable and low-risk home ownership. In P. Boelhouwer, J. Doling, & M. Elsinga (Eds.), Home ownership. Getting in, getting from, getting out. Delft: IOS Press.
- Elsinga, M., & Hoekstra, J. (2005). Homeownership and housing satisfaction. *Journal of Housing and the Built Environment*, 20, 401-424.
- Enserink, B., Hermans, L., Kwakkel, J., Thissen, W., Koppenjan, J., & Bots, P. (2010). Policy Analysis of Multi-Actor Systems The Hague: Uitgeverij LEMMA.
- Esquivel, M. T. (2008). Conjuntos Habitacionales, imaginarios de vida colectiva. *Iztapalapa*, 64-65(29), 117-143. doi:http://tesiuami.uam.mx/revistasuam/iztapalapa/viewarticle.php?id=1653
- Fallow, G., & Brown, R. B. (2002). Focusing on focus groups: lessons from a research project involving a Bangladeshi community *Qualitative Research*, 2(2), 195-208.
- Ferguson, B., & Navarrete, J. (2003). New approaches to progressive housing in Latin America: A key to habitat programs and policy. *Habitat International*, 27(2), 309-323. doi:http://dx.doi.org/10.1016/S0197-3975(03)00013-4
- Ferguson, B., Rubinstein, J., & Vial, V. D. (1996). THE DESIGN OF DIRECT DEMAND SUBSIDY PROGRAMS FOR HOUSING IN LATIN AMERICA. *Review of Urban & Regional Development Studies*, 8(2), 202-219. doi:10.1111/j.1467-940X.1996.tb00118.x
- Florian, A. (2012). El Derecho a la Vivienda. In J. F. Pinilla & M. Rengifo (Eds.), *La Ciudad y el Derecho*. Bogota: Editorial TEMIS.
- Forero S., F. E., & Forero F., J. A. (2009). *Vivienda Social, Modernidad e Informalidad en Bogota (1911-1982)*. Bogota: Universidad La Gran Colombia.
- Galster, G. C. (1983). Empirical Evidence on Cross-Tenure Differences in Home Maintenance and Conditions. *Land Economics*, 59(1), 107-113. doi:10.2307/3145880
- Galster, G. C. (1987). *Homeowners and Neighborhood Reinvestment*: Duke University Press.
- Garcia, J. (Producer). (2014). *Tratados Internacionales de Derechos Humanos: Diferenciación con otros tratados [International Human Rights Treaties: Differentiation with other treaties]*. Retrieved from <http://www.derechoecuador.com/articulos/detalle/archive/doctrinas/derechoconstitucional/2014/01/23/tratados-internacionales-de-derechos-humanos--diferenciacion--con-otros-tratados>
- Giddens, A. (1979). *Central Problems in Social Theory. Action, structure and contradiction in social analysis*. London: The Macmillan Press Ltd.
- Gilbert, A. (2004). Helping the poor through housing subsidies: lessons from Chile, Colombia and South Africa. *Habitat International*, 28, 13-40.
- Gilbert, A. (2012a). De Soto's The Mystery of Capital: reflections on the book's impact. *International Development Planning Review*, 34(2).
- Gilbert, A. (2012b). *Housing Abroad: Latin America*. The Encyclopedia of Housing. SAGE Publications, Inc. Thousand Oaks, CA: SAGE Publications, Inc.
- Gilbert, A. G., & Ward, P. M. (1982). Residential Movement among the Poor: The Constraints on Housing Choice in Latin American Cities. *Transactions of the Institute of British Geographers*, 7(2), 129-149. doi:10.2307/622218
- Glaser, B. G., & Strauss, A. L. (1967). *The Discovery of Grounded Theory: strategies for qualitative reserach* New York: Aldine de Gruyter
- Glasse, M., & Berrisfor, S. (2015). Urban Law: A Key to Accountable Urban Government and Effective Urban Service Delivery In J. Wouters, A. Ninio, T. doherly, & H. Cissé (Eds.), *The World Banck Legal Review. Improving Delivery in Development: The Role of Voice, Social Contract and Accountability (Vol. 6)*. Washington DC: The World Bank
- Greene, J. C., Caracelli, V. J., & Graham, W. F. (1989). Toward a Conceptual Framework for Mixed-Method Evaluation Designs. *Eduation Evaluation and Policy Analysis*, 11(3), 255-274.

- Grover, R., Munro-Faure, P., & Solviev, M. (2002). Housing Tenure change in the transitional economies. In G. Payne (Ed.), *Land, Rights & Innovation : Improving Tenure Security for the Urban Poor*. London: ITDG.
- Groves, R., Murie, A., & Watson, C. (2007). *Housing and the new welfare state. Perspectives from East Asia and Europe*. Aldershot: Ashgate.
- Guest, G. (2012). Describing Mixed Methods Research: An Alternative to Typologies. *Journal of Mixed Methods Research*, 20(10), 1-11.
- Haffner, M., Hoekstra, J., Oxley, M., & Heijden, H. V. D. (2010). Universalistic, Particularistic and Middle Way Approaches to Comparing the Private Rental Sector. *International Journal of Housing Policy*, 10(4), 357-377. doi:10.1080/14616718.2010.526400
- Haffner, M., Hoekstra, J., Oxley, M., & Van Der Heijden, H. (2009). *Bridging the Gap Between Social and Market Rental Housing in Six European Countries* Amsterdam: IOS Press.
- Hansmann, H. (1991). Condominium and Cooperative Housing: Transactional Efficiency, Tax Subsidies and Tenure Choice. *Journal of Legal Studies*, 20.
- Hardin, G. (1968). The Tragedy of the Commons. *Science*, 162(3859), 1243-1248. doi:10.1126/science.162.3859.1243
- Hardin, R. (1992). The Street-Level Epistemology of Trust. *Analyse and Kritik*, 14, 152-176.
- Harloe, M., & Martens, M. (1984). Comparative Housing Research. *Journal of Social Policy*, 13(03), 255-277. doi:10.1017/S0047279400013751
- Heijden, H. V. d. (2013). *West European Housing Systems in a Comparative Perspective (Vol. 46)*. Delft: IOS.
- Held, G. (2000). Políticas de vivienda de interes social orientadas al mercado: experiencias recientes con subsidios a la demanda en Chile, Costa Rica y Colombia. Retrieved from Santiago: http://repositorio.cepal.org/bitstream/handle/11362/5304/S00050485_es.pdf?sequence=1
- Hennink, M., Hutter, I., & Bailey, A. (2011). *Qualitative Reserach Methods*. London: SAGE.
- Ho, D. C. W., & Gao, W. (2013). Collective action in apartment building management in Hong Kong. *Habitat International*, 38, 10-17.
- Hoekstra, J. (2010). *Divergence in European welfare and housing systems (Vol. 38)*. Delft: IOS Press BV, Delft Univeristy Press.
- Hsieh, H. R. (2009). Issues and proposed improvements regarding condominium management in Taiwan. *Habitat International*, 33, 73-80.
- Kemeny, J. (1992). *Housing and social theory*. London: Routledge.
- Kemeny, J., & Lowe, S. (1998). Schools of Comparative Housing Research: From Convergence to Divergence. *Housing Studies*, 13(2), 161-176. doi:10.1080/02673039883380
- Kickert, W. J. M., Klijn, E.-H., & F.M.Koppenjan, J. (Eds.). (1997). *Managing Complex Networks : Strategies for the Public Sector*. London: SAGE Publications.
- Klaufus, C. (2010). The two ABCs of aided self-help housing in Ecuador. *Habitat International*, 34, 351-358.
- Kleinhans, R., & Bolt, G. (2013). More than just fear: on the intricate interplay between perceived neighborhood disorder, collective efficacy, and action *Journal of Urban Affairs*, 36(3), 420-446.
- Krueger, R. A., & Casey, M. A. (2009). *Focus Groups. A Practical Guide for Applied Research*. Thousand Oaks: SAGE.
- Lennartz, C. (2011). Power Structures and Privatization across Integrated Rental Markets: Exploring the Cleavage between Typologies of Welfare Regimes and Housing Systems. *Housing, Theory and Society*, 28(4), 342-359. doi:10.1080/14036096.2011.562626
- Littlewood, A., & Munro, M. (1996). Explaining disrepair: Examining owner occupiers' repair and maintenance behaviour. *Housing Studies*, 11(4), 503-525. doi:10.1080/02673039608720872
- Lizarralde, G. (2015). *The invisible housing*. New York: Routledge.
- Lowry, G. (2002). Modelling user acceptance of building management systems. *Automation in Construction*, 11(6), 695-705. doi:http://dx.doi.org/10.1016/S0926-5805(02)00010-9
- Lujanen, M. (2010). Legal challenges in ensuring regular maintenance and repairs of owner-occupied apartment blocks. *International Journal of Law in the Built Environment*, 2(2), 178-197. doi:10.1108/17561451011058807
- Maldonado, M. M. (2005). Es posible anticiparse a la urbanización informal? Reflexiones a partir de la Operación Urbanística Nuevo Usme, Bogota y del MacroProyecto Ciudadela Gonzalo Vallejo Restrepo, Pereira (Colombia). Retrieved from Bogota:
- Malpass, P. (2011). Path Dependence and the Measurement of Change in Housing Policy. *Housing, Theory and Society*, 28(4), 305-319. doi:10.1080/14036096.2011.554852

- Mangin, W. (1967). Latin American squatter settlements: a problem and a solution. *Latin American Research Review*, 2(3), 65-98.
- Marcuse, P. (1972). Homeownership for Low Income Families: Financial Implications. *Land Economics*, 48(2), 134-143.
- McGinnis, M. D., & Ostrom, E. (2014). Social-ecological system framework: initial changes and continuing challenges. *Ecology and Society*, 19(2). doi:10.5751/es-06387-190230
- McKenzie, E. (1994). *Privatopia: Homeowners Associations and the Rise of Residential Private Government*. New Haven: Yale University Press.
- Meijer, F., & Smid, I. (1994). Vereniging van Eigenaren: Ervaringen en Perspectieven Retrieved from
- Mejia, M. E. (2006). Del discurso de vivienda al espacio residencial. El caso de vivienda en altura en sistema constructivo de cajón. (Master), Universidad Nacional, Medellin.
- Merwe, C. G. v. d. (2008). The Adaptation of the Institution of Apartment Ownership to Civilian Property Law Structures in the Mixed Jurisdictions of South Africa, Sri Lanka and Louisiana *Electronic Journal of Comparative Law*, 12(1). Retrieved from <http://www.ejcl.org/121/art121-25.pdf>
- Merwe, C. V. D. (2015). *European Condominium Law*. Cambridge: Cambridge University Press.
- Molsalve, G. A. (2003). El Sistema de Subsidio Familiar en la Seguridad Social Colombiana. *VNIVERSITAS*, 106, 455-504.
- Montoya, A. P. (2004). *Vivienda Moderna en Colombia [Modern housing in Colombia] (Vol. 10)*. Bogota: Universidad Nacional de Colombia.
- Moser, C. (1998). The asset vulnerability framework: Reassessing urban poverty reduction strategies. *World Development*, 26(1), 1-19. doi:[http://dx.doi.org/10.1016/S0305-750X\(97\)10015-8](http://dx.doi.org/10.1016/S0305-750X(97)10015-8)
- Moser, C. (2009). *Ordinary Families, Extraordinary Lives*. Washington D.C.: Brookings Institution Press.
- Mossel, J. H. v. (2008). The purchasing of maintenance service delivery in the Dutch social housing sector: optimising commodity strategies for delivering maintenance services to tenants. (Proefschrift PhD), Delft University of Technology Delft.
- Nee, V. (1998). Norms and Networks in Economic and Organizational Performance. *The American Economic Review*, 88(2), 85-89. doi:10.2307/116898
- Nee, V., & Ingram, P. (1998). Embeddedness and Beyond: Institutions, Exchange, and Social Structure In M. C. Brinton & V. Nee (Eds.), *The New Institutionalism in Sociology* Stanford: Stanford University Press.
- North, D. (1994). Economic Performance Through Time. *The American Economic Review*, 83(3), 359-368.
- Olson, M. (1965). *Logic of Collective Action (Ninth Print, 1982 ed.)*. Cambridge: Harvard University Press.
- Orban, A. (2006). *Community action for collective goods: an interdisciplinary approach to the internal and external solutions to collective action problems. The case of Hungarian Condominiums Budapest: Akademiaiai Kiado*
- Ostrom, E. (1990). *Governing the Commons: the evolutions of institutions for collective action* Cambridge: Cambridge University Press.
- Ostrom, E. (2003). How Types of Goods and Property Rights Jointly Affect Collective Action. *Journal of Theoretical Politics*, 15(3), 239-270. doi:10.1177/0951692803015003002
- Ostrom, E. (2005). *Understanding Institutional Diversity* Princeton: Princeton University Press.
- Ostrom, E., Gardner, R., & Walker, J. (2006). *Rules, Games and Common-Pool Resources*. Ann Arbor: University of Michigan Press.
- Ostrom, E. (2007). A diagnostic approach for going beyond panaceas. *Proceedings of the National Academy of Sciences*, 104(39), 15181-15187. doi:10.1073/pnas.0702288104
- Ostrom, E. (2009a). *Beyond Markets and States: Polycentric Governance of Complex Economic Systems*. Paper presented at the Nobel Prize Lecture
- Ostrom, E. (2009b). Design Principles of Robust Property Rights Institutions: What Have We Learned? In G. K. Ingram & Y.-H. Hong (Eds.), *Property Rights and Land Policies* Cambridge: Lincoln Institute of Land Policy
- Ostrom, E. (2009c). A General Framework for Analyzing Sustainability of Social-Ecological Systems. *Science*, 325(5939), 419-422. doi:10.1126/science.1172133
- Ostrom, E. (2010). *Beyond Markets and States: Polycentric Governance of Complex Economic Systems*. *The American Economic Review*, 100(3), 641-672. doi:10.2307/27871226
- Oxley, M. (2001). Meaning, science, context and confusion in comparative housing research. *Journal of Housing and the Built Environment*, 16(1), 89-106. doi:10.1023/A:1011599006494
- Oxley, M., & Haffner, M. (2012). *Comparative Housing Research*. In S. J. Smith (Ed.), *International Encyclopedia of Housing and Home (Vol. 1, pp. 199-209)*. Amsterdam: Elsevier.

- Paquette-Vasalli, C., & Sanchez, M. Y. (2009). Massive housing production in Mexico City: debating two policies. *Centro h, Revista de la Organización Latinoamericana y del Caribe de Centros Históricos*, 3, 1390-4361. Retrieved from <http://www.redalyc.org/pdf/1151/115112536002.pdf>
- Park, S., & Baek, C. (2012). Fiscal instruments for sustainable maintenance of apartment housing in Korea. *Renewable and Sustainable Energy Reviews*, 16(7), 4432-4444. doi:<http://dx.doi.org/10.1016/j.rser.2012.05.012>
- Paz, R. D. O. d. (2014). Avaliação do Trabalho Social e dos Impactos na Vida das Famílias no Programa Minha Casa Minha Vida, no Município de Osasco/SP. Paper presented at the III Encontro da Associação Nacional de Pesquisa e Pós-graduação em Arquitetura e Urbanismo; Arquitetura, cidade e projeto: uma construção coletiva Sao Paulo.
- Pickvance, C. (2001). Four varieties of comparative analysis. *Journal of Housing and the Built Environment*, 16(1), 7-28. doi:10.1023/A:1011533211521
- Piketty, T. (2014). *Capital in the Twenty-First Century*. Cambridge: The Belknap Press of Harvard University Press.
- Ploeger, R., Lawson, J., & Bontje, M. (2001). The methodological challenge to comparative research *Journal of Housing and the Built Environment*, 16.
- Poteete, A. R., Janssen, M. A., & Ostrom, E. (2010). *Working together: collective action, the commons, and multiple methods in practice*. New Jersey: Princeton University Press.
- Poteete, A. R., & Ostrom, E. (2004). Heterogeneity, Group Size and Collective Action: The Role of Institutions in Forest Management. *Development and Change*, 35(3), 435-461. doi:10.1111/j.1467-7660.2004.00360.x
- Rabenhorst, C. S., & Ignatova, S. I. (2009). Condominium Housing and Mortgage Lending in Emergin Markets - Constraints and Opportunities. Retrieved from
- Robertson, D. (2012). Collective Ownership. In S. J. Smith (Ed.), *International Eyclopedia of Housing and Home* (Vol. 1, pp. 181-185). Amsterdam Elsevier.
- Rodriguez, A., & Sugranyes, A. (Eds.). (2005). *Los con techo. Un desafío para la política de vivienda social. [Those with Roofs. A Challenge for Social Housing Policy]* Santiago de Chile: Ediciones Sur
- Rohan, P. J. (1967). Perfecting The Condominium as a Housing Tool: Innovation in Tort Liability and Insurance. *Law and Contemporary Problems*, 32(2), 305-318.
- Rohan, P. J. (1978). The "Model Condominium Code" a Blueprint for modernizing condominium legislation *Columbia Law Review*, 18(3), 587-608.
- Rohe, W. M., & Basolo, V. (1997). Long-Term Effects of Homeownership on the Self-Perceptions and Social Interaction of Low-Income Persons. *Environment and Behavior*, 29(6), 793-819. doi:10.1177/0013916597296004
- Rojas, E. (2001). The Long Road to Housing Sector Reform: Lessons from the Chilean Housing Experience. *Housing Studies*, 16(4), 461-483. doi:10.1080/02673030120066554
- Rojas, E. (Ed.) (2010). *Building cities: Neighbourhood upgrading and urban quality of life*. Washington, D.C.: Inter-American Development Bank.
- Rolnik, R. (2013). Late Neoliberalism: The Financialization of Homeownership and Housing Rights. *International Journal of Urban and Regional Research*, 37(3), 1058-1066. doi:10.1111/1468-2427.12062
- Rolnik, R., & Royer, L. d. O. (2014). O programa Minha Casa Minha Vida nas Regiões Metropolitanas de São Paulo e Campinas: aspectos socioespaciais e segregação Paper presented at the III Encontro da Associação Nacional de Pesquisa e Pós-graduação em Arquitetura e Urbanismo; Arquitetura, cidade e projeto: uma construção coletiva Sao Paulo.
- Ronald, R. (2005). Meanings of property and home ownership consumption in divergent socio-economic conditions. In J. Doling & M. Elsinga (Eds.), *Home ownership. Getting in, getting from, gettin out. Part II* (Vol. 30). Delft: IOS Press.
- Ronald, R. (2008). *the ideology of Home Owership: Homeowner Societies and the Housing of Housing Basingstoke*: Palgrave Macmillan.
- Ronald, R., & Hirayama, Y. (2006). Housing Commodities, Context and Meaning: Transformations in Japan's Urban Condominium Sector. *Urban Studies*, 43(13), 2467-2483.
- Rosen, G., & Walks, A. (2013). Rising cities: Condominium development and the private transformation of the metropolis. *Geoforum*, 49(0), 160-172. doi:<http://dx.doi.org/10.1016/j.geoforum.2013.06.010>
- Ruonavaara, H. (1993). Types and forms of housing tenure: Towards solving the comparison/translation problem *Scandinavian Housing and Planning Research*, 10(1), 3-20.

- Ruttan, Lore M. (2006). Sociocultural Heterogeneity and the Commons. *Current Anthropology*, 47(5), 843-853. doi:10.1086/507185
- Saunders, P. (1990). *A Nation of Home Owners*. London: Unwin Hyman.
- Scanlon, E. (1998). Low-Income Homeownership Policy as a Community Development Strategy. *Journal of Community Practice*, 5(1-2), 137-154. doi:10.1300/J125v05n01_09
- Schlager, E., & Ostrom, E. (1992). Property-Rights Regimes and Natural Resources: A Conceptual Analysis. *Land Economics*, 68(3), 249-262. doi:10.2307/3146375
- Simpson, B. (2006). Social Identity and Cooperation in Social Dilemmas. *Rationality and Society*, 18(4), 443-470. doi:10.1177/1043463106066381
- Simpson, B., Willer, R., & Ridgeway, C. L. (2012). Status Hierarchies and the Organization of Collective Action. *Sociological Theory*, 30(3), 149-166. doi:10.1177/0735275112457912
- Soaita, A. M. (2012). Strategies for In Situ Home Improvement in Romanian Large Housing Estates. *Housing Studies*, 27(7), 1008-1030. doi:10.1080/02673037.2012.725833
- Sørensen, E., & Torfing, J. (Eds.). (2007). *Theories of Democratic Network Governance*. Houndmills: Palgrave Macmillan.
- Stephens, M. (2011). Comparative Housing Research: A 'System-Embedded' Approach. *International Journal of Housing Policy*, 11(4), 337-355. doi:10.1080/14616718.2011.626598
- Stewart, D. W., & Shamdasani, P. N. (1990). *Focus Groups: Theory and Practice*. Newbury Park : Sage.
- Straub, A. (2002). Strategic technical management of housing stock: lessons from Dutch housing associations. *Building Research & Information*, 30(5), 372-381. doi:10.1080/09613210210150955
- Termeer, C. J. A. M., & Koppenjan, J. F. M. (1997). Managing Perceptions in Networks In W. J. M. Kickert, E.-H. Klijn, & J. F. M. Koppenjan (Eds.), *Managing Complex Networks. Strategies for the Public Sector* (pp. 79-97). London: SAGE.
- Toussaint, J. (2011). Housing wealth in retirement strategies. Towards understanding and new hypotheses (Vol. 42). Delft: IOS Press.
- UN-HABITAT. (2010). 5 Selected Topics of the Latin American Habitat (5 Temas Selectos del Hábitat Latinoamericano). Retrieved from
- UN-HABITAT. (2011). Affordable Land and Housing in Latin America and the Caribbean. Retrieved from Nairobi:
- UN-HABITAT. (2014). The Right to Adequate Housing. Retrieved from Geneva: http://www.ohchr.org/Documents/Publications/FS21_rev_1_Housing_en.pdf
- Van Bortel, G. (2012). Institutions and Governance Networks in Housing and Urban Regeneration. In S. J. Smith, M. Elsinga, L. F. O'Mahony, O. S. Eng, S. Wachter, & S. Tsenkova (Eds.), *International Encyclopedia of Housing and Home* (Vol. 4, pp. 93-98). Oxford: Elsevier.
- Van Bortel, G. (2016). Networks and Fault lines. Understanding the role of housing associations in neighborhood regeneration: a network governance perspective. Delft: Delft University of Technology
- Van der Heijden, H. (2013). West European Housing Systems in a Comparative Perspective (Vol. 46). Delft: IOS.
- Van Weesep, J. (1984). Condominium Conversion in Amsterdam: Boon or Burden? . *Urban Geography*, 5(2), 165-177. doi:10.2747/0272-3638.5.2.165
- Van Weesep, J. (1987). "The creation of a new housing sector: condominiums in the United States". *Housing Studies* 2, 122-133
- Ward, P., Jiménez, E., & Virgilio, M. D. (Eds.). (2014). *Housing Policy in Latin American Cities. A New Generation of strategies and Approaches for 2016 UN Habitat III*. New York: Routledge.
- Werczberger, E., & Ginsberg, Y. (1987). Maintenance of shared property in low-income condominiums. *Housing Studies*, 2(3), 192-202.
- Williamson, O. E. (2000). The New Institutional Economics: Taking Stock, Looking Ahead. *Journal of Economic Literature*, 38(3), 595-613. doi:doi: 10.1257/jel.38.3.595
- Yau, Y. (2011). Collectivism and activism in housing management in Hong Kong. *Habitat International*, 35, 327-334.
- Yau, Y. (2012). Normas, sentido de comunidad y colectivismo comunal en un contexto de edificios en altura. *Revista INVI*, 27, 17-72.
- Yau, Y. (2014). Perceived efficacies and collectivism in multi-owned housing management. *Habitat International*, 43(0), 133-141. doi:http://dx.doi.org/10.1016/j.habitatint.2014.02.009
- Yau, Y., & Ho, D. C. W. (2009). The effects of building management practices on residential property prices in Hong Kong. *Journal of Building Appraisal*, 4, 157-167. doi:10.1057/jba.2008.42

- Yip, N. M. (2010). Management Rights in Multi-owned Properties in Hong Kong. In S. Blandy, A. Dupuis, & J. Dixon (Eds.), *Multi-owned housing: law, power and practice* (pp. 109-124). Surrey: Ashgate Publishing Limited
- Zanetta, C. (2001). The Evolution of the World Bank's urban lending in Latin America: from sites and services to municipal reform and beyond. *Habitat International*, 25(4), 513-533.

Curriculum vitae

Rosa Elena Donoso Gomez was born on 25 March, 1978 in Guayaquil, Ecuador, and grew up mainly in the capital, Quito. She completed a professional degree in Architecture from Universidad San Francisco de Quito with a minor in sociology in 2002, and received her Masters of Science in Community and Regional Planning at the University of Texas at Austin in 2008, with a focus on housing studies. Her professional experience combines both architecture and urban planning as well as academic research and teaching.

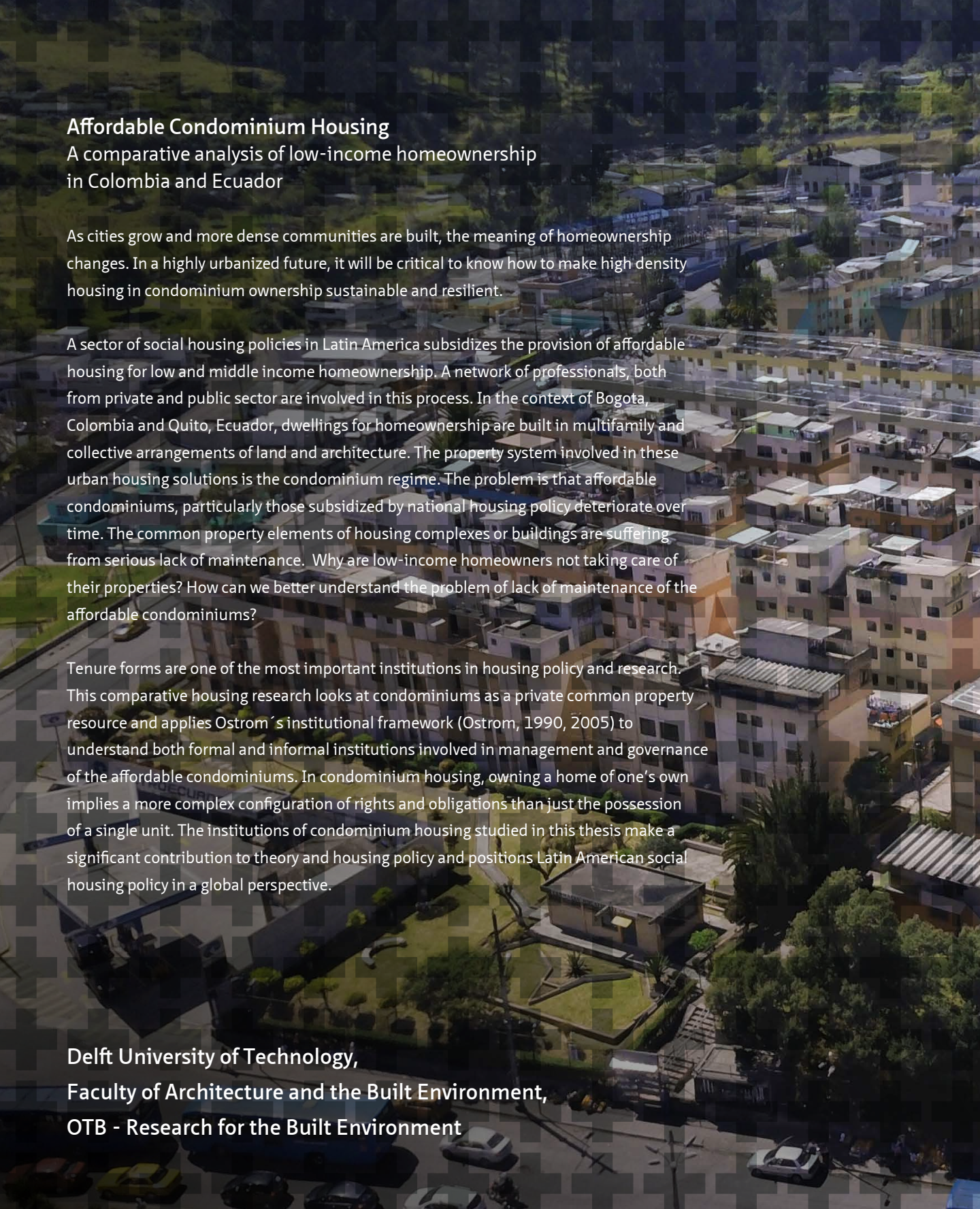
Rosa Elena has worked as a consultant for municipalities on urban plans such as with the Comprehensive Plan for the Historic Center of Quito (2003), Santo Domingo Norte informal settlement in the Dominican Republic (2008), Turubamba Sur in Quito (2011), and Santo Domingo de los Tsachilas, Ecuador (2011). She has participated in different research projects such as the participatory risk and vulnerability assessment of an informal settlement in Santo Domingo in the Dominican Republic, a project recognized by an award from the American Planning Association (2009). At the Instituto de la Ciudad, the municipality of Quito's research institute, she developed research on territorial governance, producing research articles and a book about quality of life in Quito (2009).

She has teaching experience both at undergraduate and master's levels. At UT-Austin, she was a teacher assistant of the as Physical Planning class at the master's level and Construction at the undergraduate level. In Quito she has taught undergraduate courses in Architecture School at San Francisco University (2010-2015) such as History and Theory of Architecture, Theories of Urban Design, and Housing and the City. Currently she teaches urban public policy courses at masters levels in Universidad Particular de Loja and Pontificia Universidad Católica de Quito.

Rosa Elena started doctoral studies at OTB Research Institute at the Faculty of Architecture and the Built Environment at TU Delft, in the Housing in the Changing Society research group in 2011, a position funded by the Nuffic-Netherlands Fellowship for PhD. She is a founding member of the A+BE PhD council at BK and worked for two years representing PhDs at the Research Council of the Faculty of Architecture of TU Delft.

In 2015 she returned to Quito, Ecuador where she worked as a housing and planning advisor at the Secretariat of Territory, Habitat and Housing of the Municipality of the Metropolitan District of Quito until the end of 2017. Currently she works at the

Ecuadorian-German cooperation program funded by GIZ, Sustainable Intermediate Cities, as the national advisor to construct the national applied research agenda for sustainable urban development, in the context of the New Urban Agenda, signed in Quito during Habitat III.



Affordable Condominium Housing

A comparative analysis of low-income homeownership in Colombia and Ecuador

As cities grow and more dense communities are built, the meaning of homeownership changes. In a highly urbanized future, it will be critical to know how to make high density housing in condominium ownership sustainable and resilient.

A sector of social housing policies in Latin America subsidizes the provision of affordable housing for low and middle income homeownership. A network of professionals, both from private and public sector are involved in this process. In the context of Bogota, Colombia and Quito, Ecuador, dwellings for homeownership are built in multifamily and collective arrangements of land and architecture. The property system involved in these urban housing solutions is the condominium regime. The problem is that affordable condominiums, particularly those subsidized by national housing policy deteriorate over time. The common property elements of housing complexes or buildings are suffering from serious lack of maintenance. Why are low-income homeowners not taking care of their properties? How can we better understand the problem of lack of maintenance of the affordable condominiums?

Tenure forms are one of the most important institutions in housing policy and research. This comparative housing research looks at condominiums as a private common property resource and applies Ostrom's institutional framework (Ostrom, 1990, 2005) to understand both formal and informal institutions involved in management and governance of the affordable condominiums. In condominium housing, owning a home of one's own implies a more complex configuration of rights and obligations than just the possession of a single unit. The institutions of condominium housing studied in this thesis make a significant contribution to theory and housing policy and positions Latin American social housing policy in a global perspective.

Delft University of Technology,
Faculty of Architecture and the Built Environment,
OTB - Research for the Built Environment