

URBAN ARCHITECTURE GRADUATION STUDIO



INDUSTRY :  
IMPETUS TO URBANITY

Dilara Turgut

“They(the objects) had a life and they are still alive. You just need to give them a second chance.”

*Agnès Varda, Les Glaneurs et la Glaneuse*



“They(the objects) had a life and they are still alive. You just need to give them a second chance.”

Agnès Varda, *Les Glaneurs et la Glaneuse*

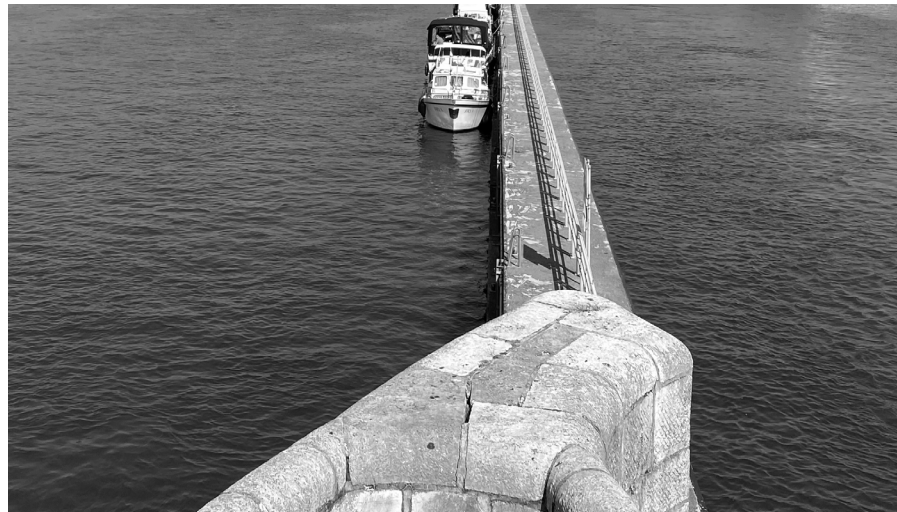



“They(the objects) had a life and they are still alive. You just need to give them a second chance.”

Agnès Varda, *Les Glaneurs et la Glaneuse*



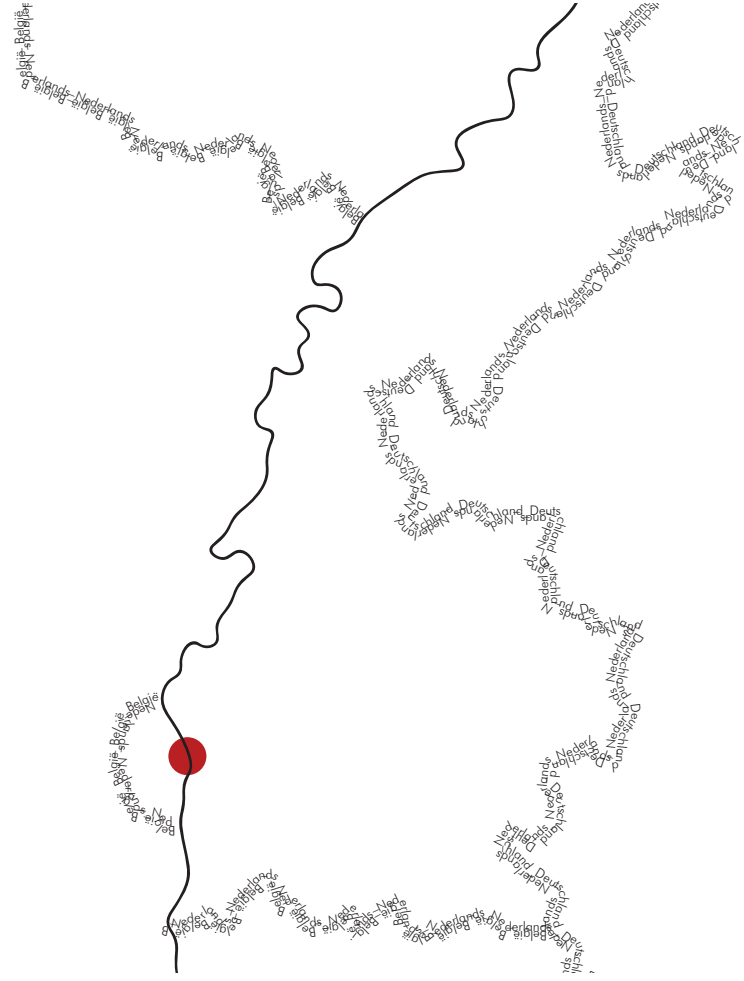

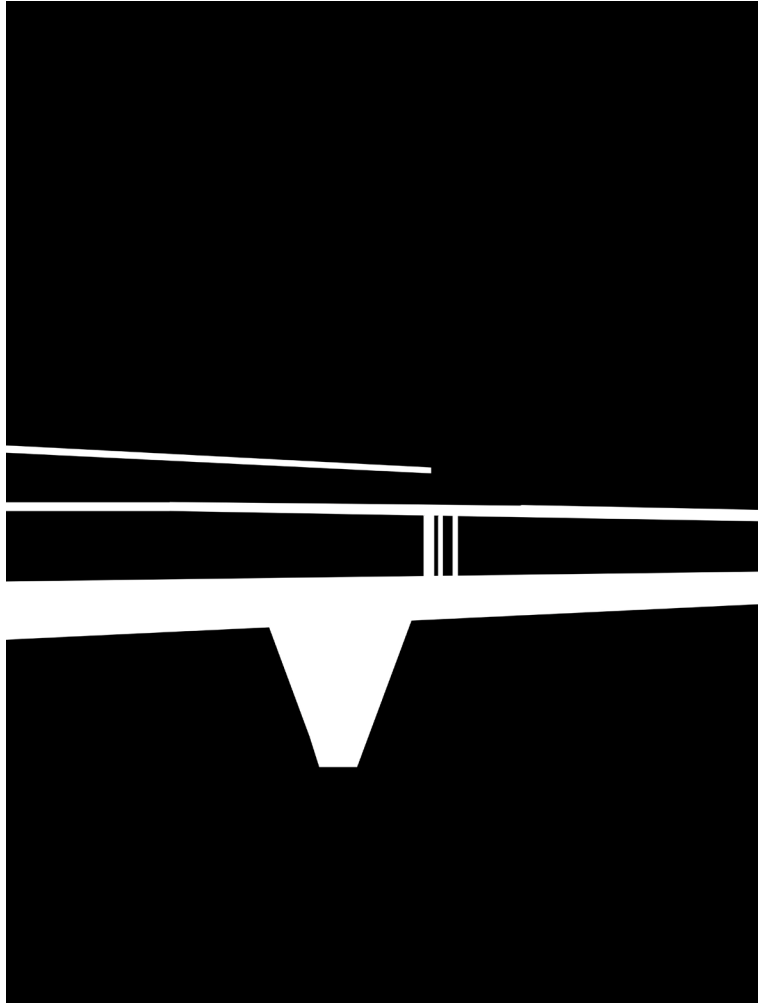



subjective territories

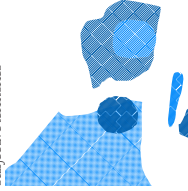

road names



future mobility



height



history - roman



jurisdictions

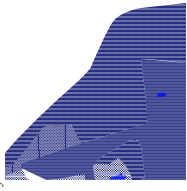

functions



mobility



built & unbuild



history - medieval



flora and fauna



transitions

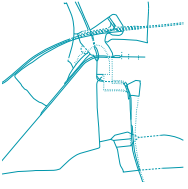

built borders

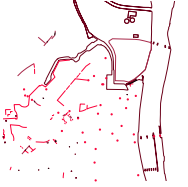

history - 2020





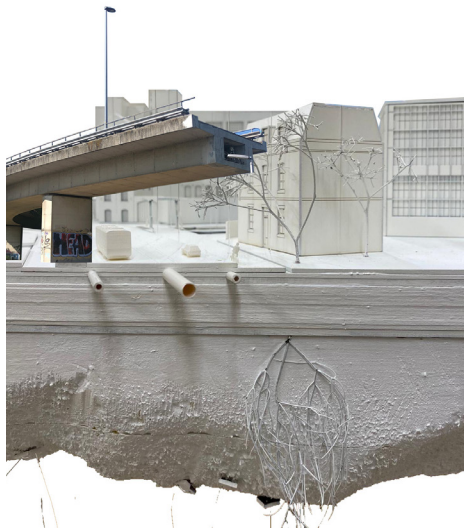

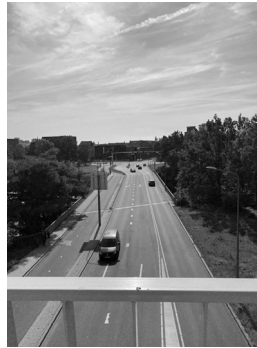

Charles Sheeler River Rouge, Plant 1932



Pierre Loup Benoit, Maastricht, 2021

understanding the segregation

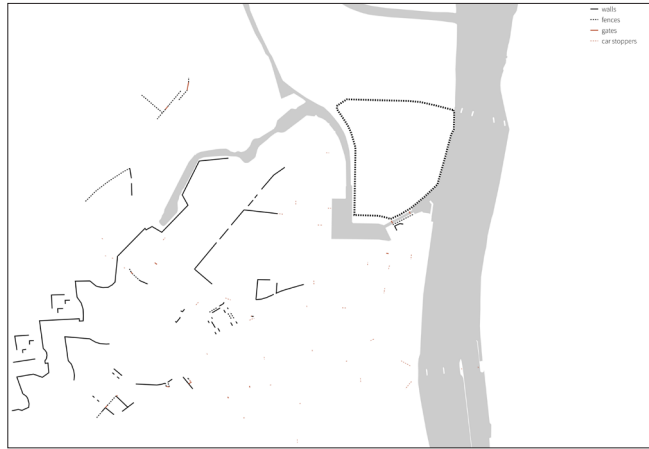

Borders



Functions

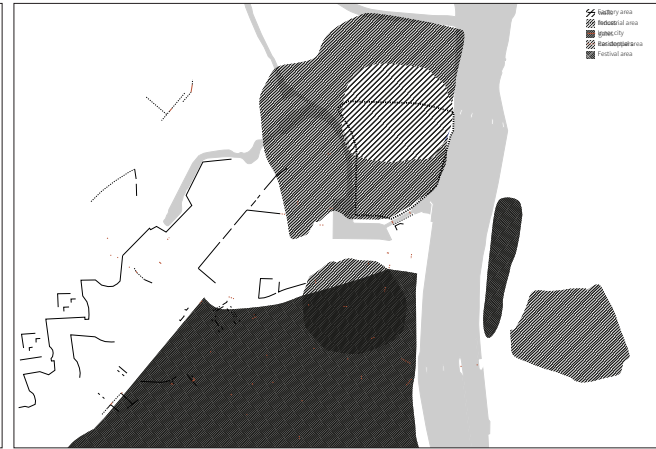

Subjective Territories

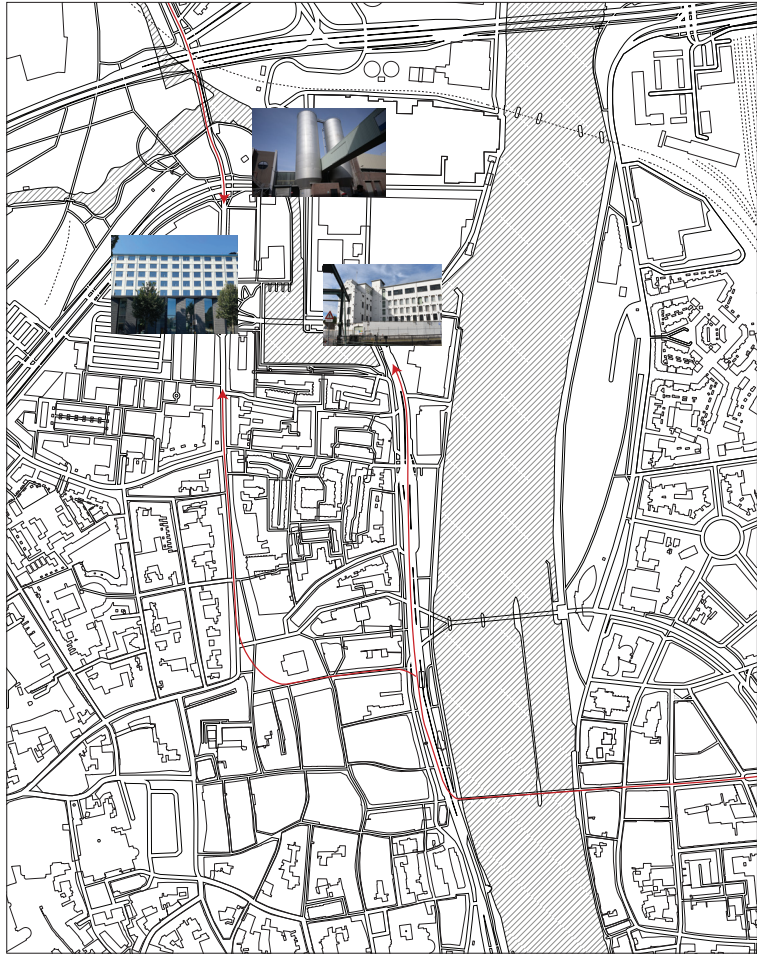

how to approach to the site

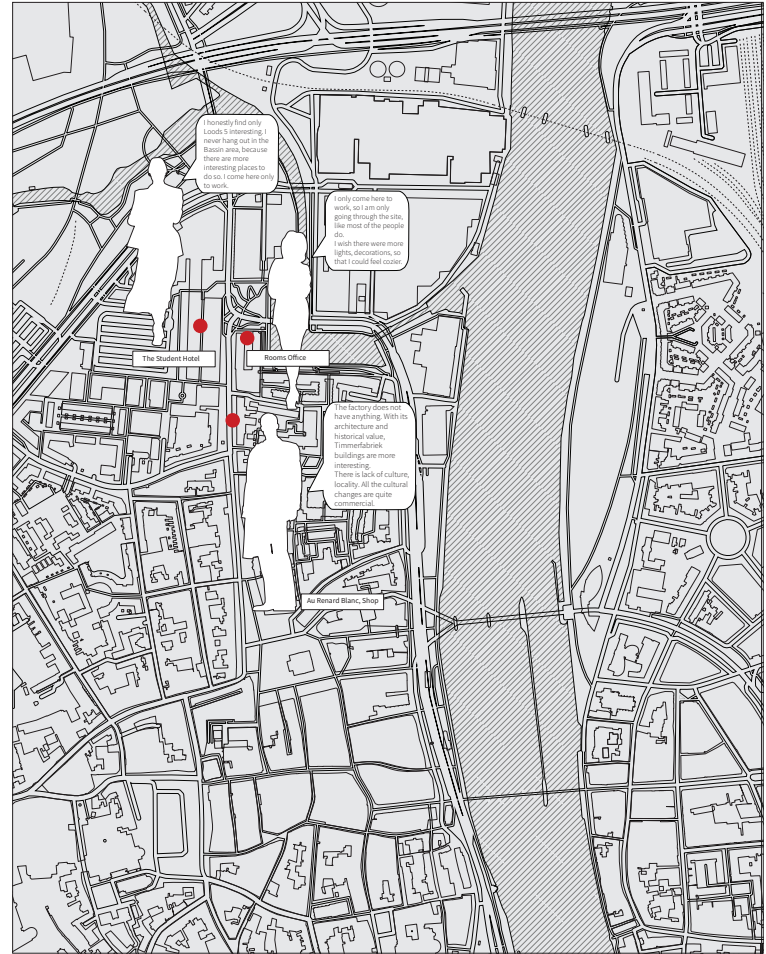

interviews

“The city is in its history.”

*Aldo Rossi, The Architecture of the City*

“The city is in its history.”  
*Aldo Rossi, The Architecture of the City*

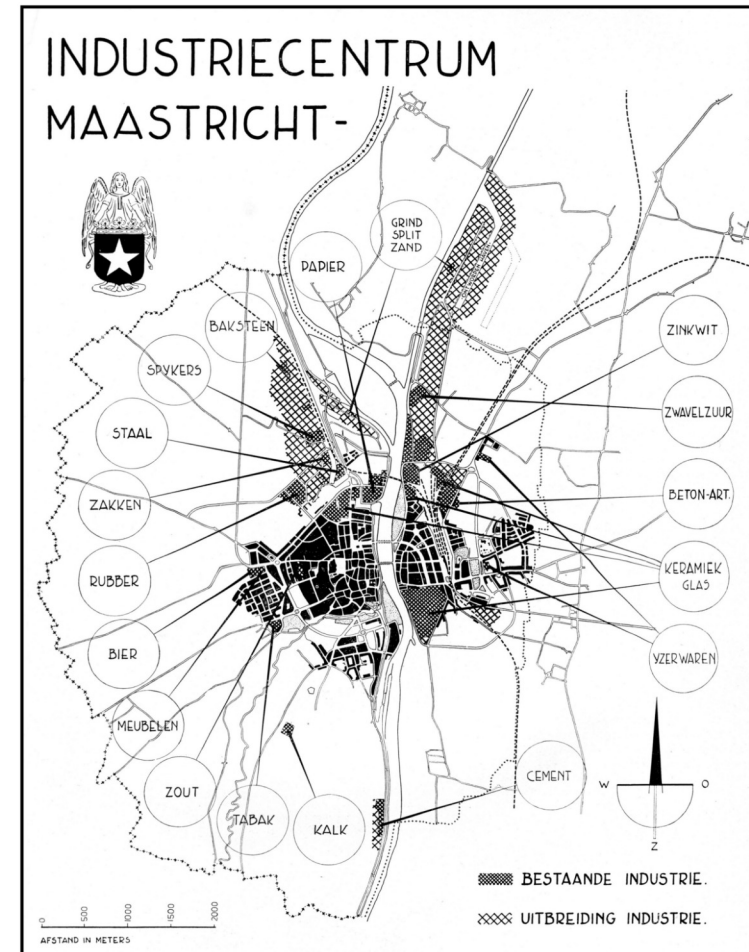

Illustratie uit: 'LIMBURG 1839-1939. Van ploeg tot afbouwamer'



Bassin, Maastricht 1935



Bassin, Maastricht 1935

19th-20th century



Industrial City Center

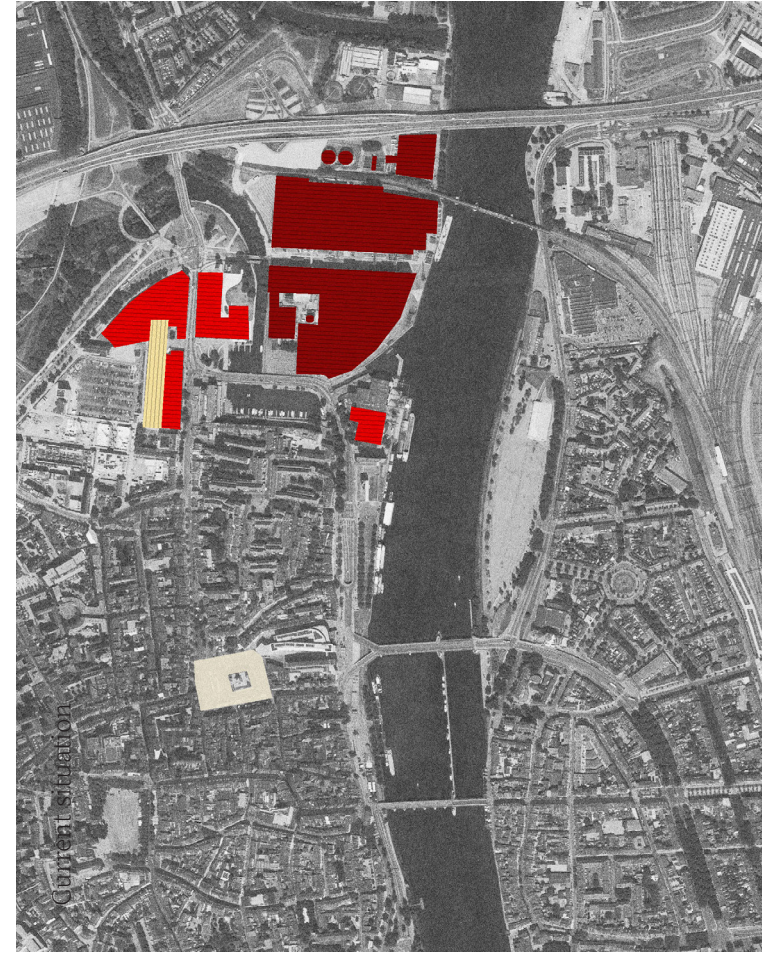

Industrial Cultural Dwelling City Center

The Student Hotel, former Sphinx Building



Abandoned Grain Factory



Lumiere Cinema, former Power Plant



Sappi Paper Factory

industry : 'diligence' and 'hard work'

Sphinx Glas Factory, n.d.



Humans?

industry : 'diligence' and 'hard work'



Sappi Maastricht

Machines?

forgotten giants

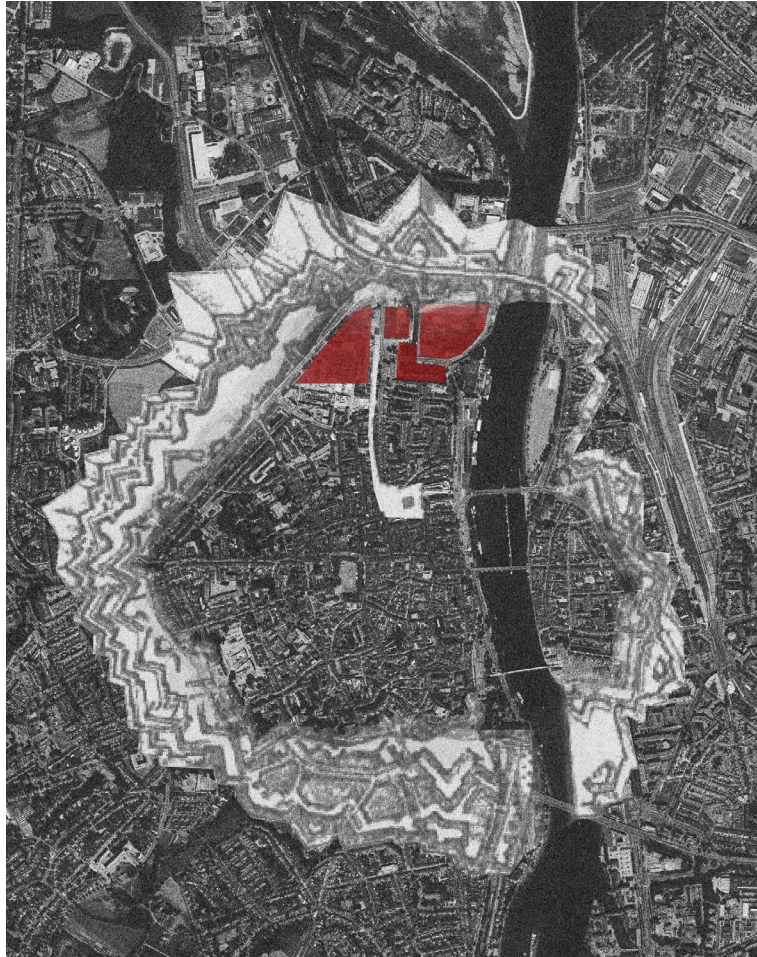

Collage map

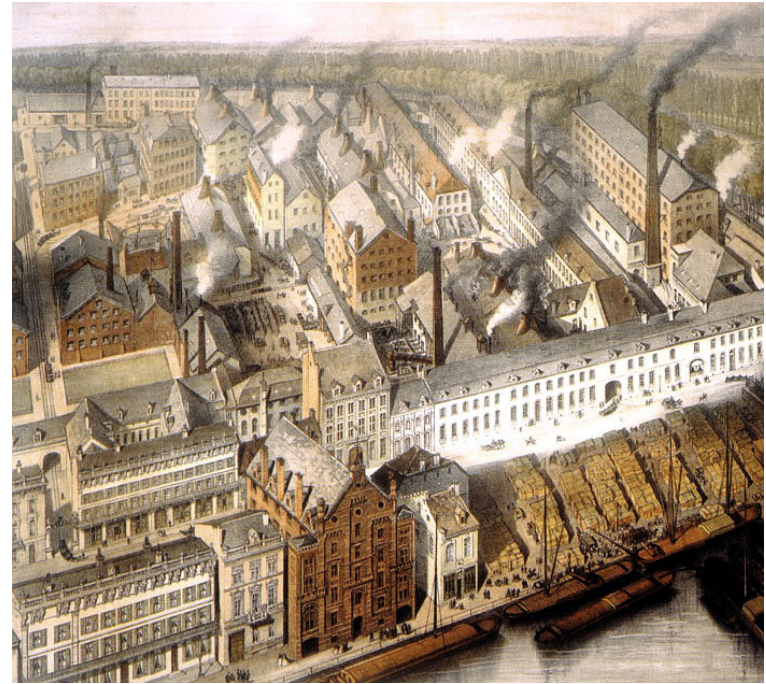

Bassin, Maastricht 1935



John Berger, Ways of Seeing, 1972





Philippus van Gulpen, Bassin, 1848

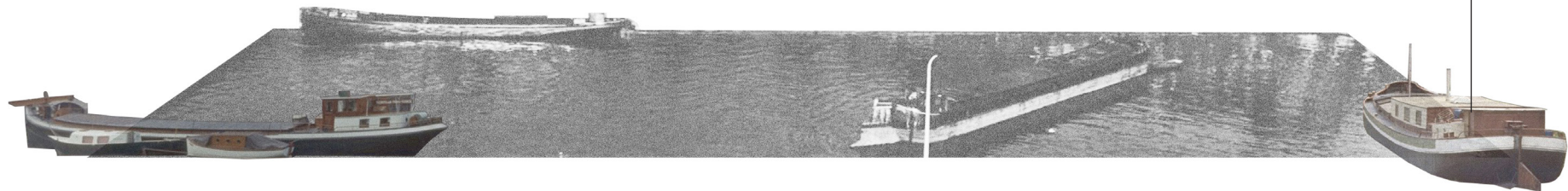

Bassin, 1826

1825

1826  
Bassin

1827  
Glass factory

1827  
Affuitenloods

1850

1826  
Bassin

1834  
De Sphinx

1827  
Affuitenloods

1851  
White Building

1875

1826  
Bassin

1905-1910  
Timmerfabriek

1906  
Power Plant

1878  
Workers' houses

1851  
White Building

1900

1826  
Bassin

1928-1941  
Eiffel Building

1905-1910  
Timmerfabriek

1906  
Power Plant

1950  
Storage

1851  
White Building

1939  
Grain Factory

1950

1826  
Bassin

1928-1941  
Eiffel Building

1905-1910  
Timmerfabriek

1906  
Power Plant

1951

1939  
Grain Factory

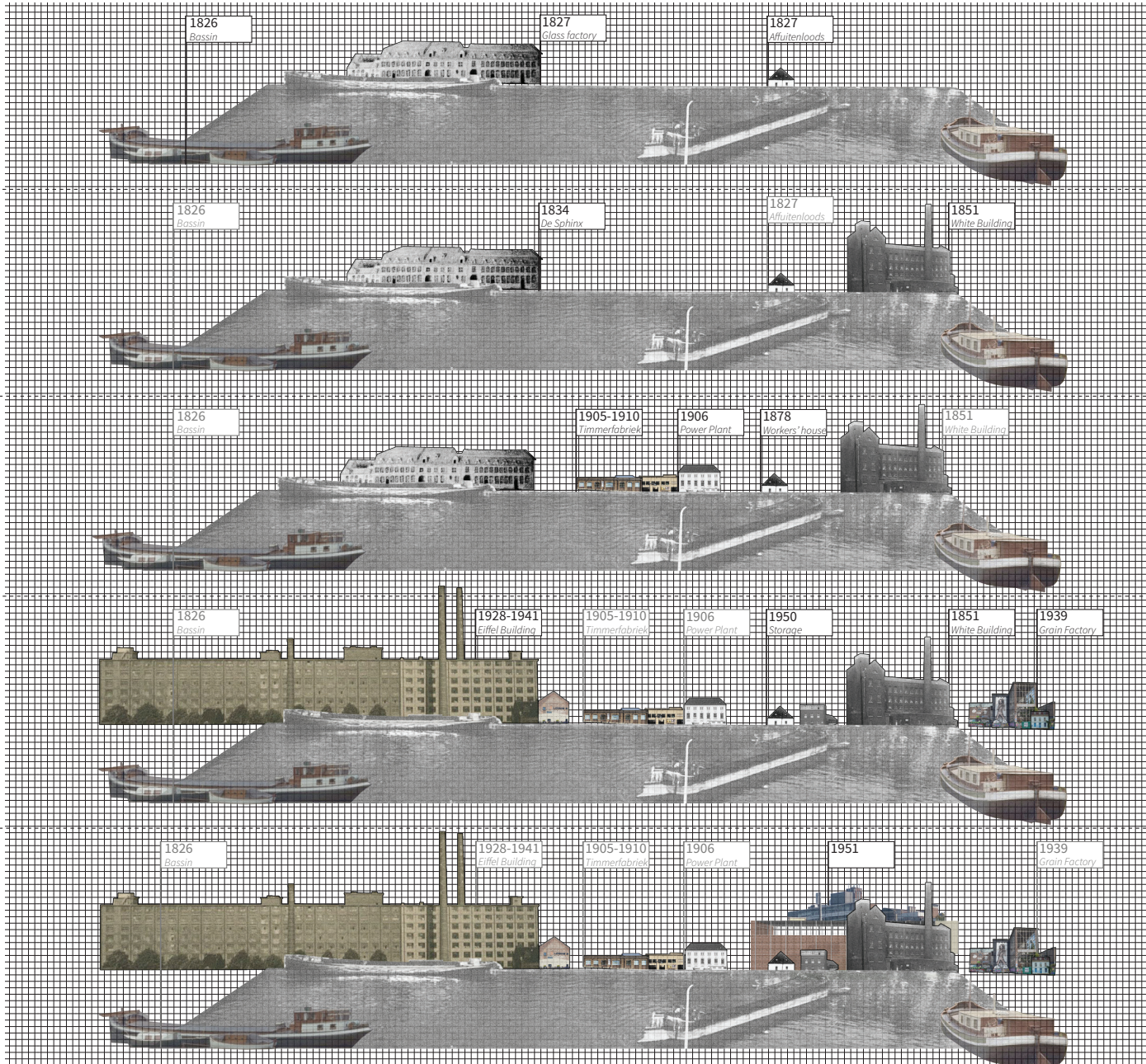



dwelling  
2016, Hotel  
*The Student Hotel*

cultural  
1999, Shop  
*Loods 5*

cultural  
2006, Museum  
*Bureau Europa*

cultural  
2006, Cinema  
*Lumiere*

Interviewee

The factory doesn't have anything. With its architecture, facade Timmerfabriek buildings are more interesting.

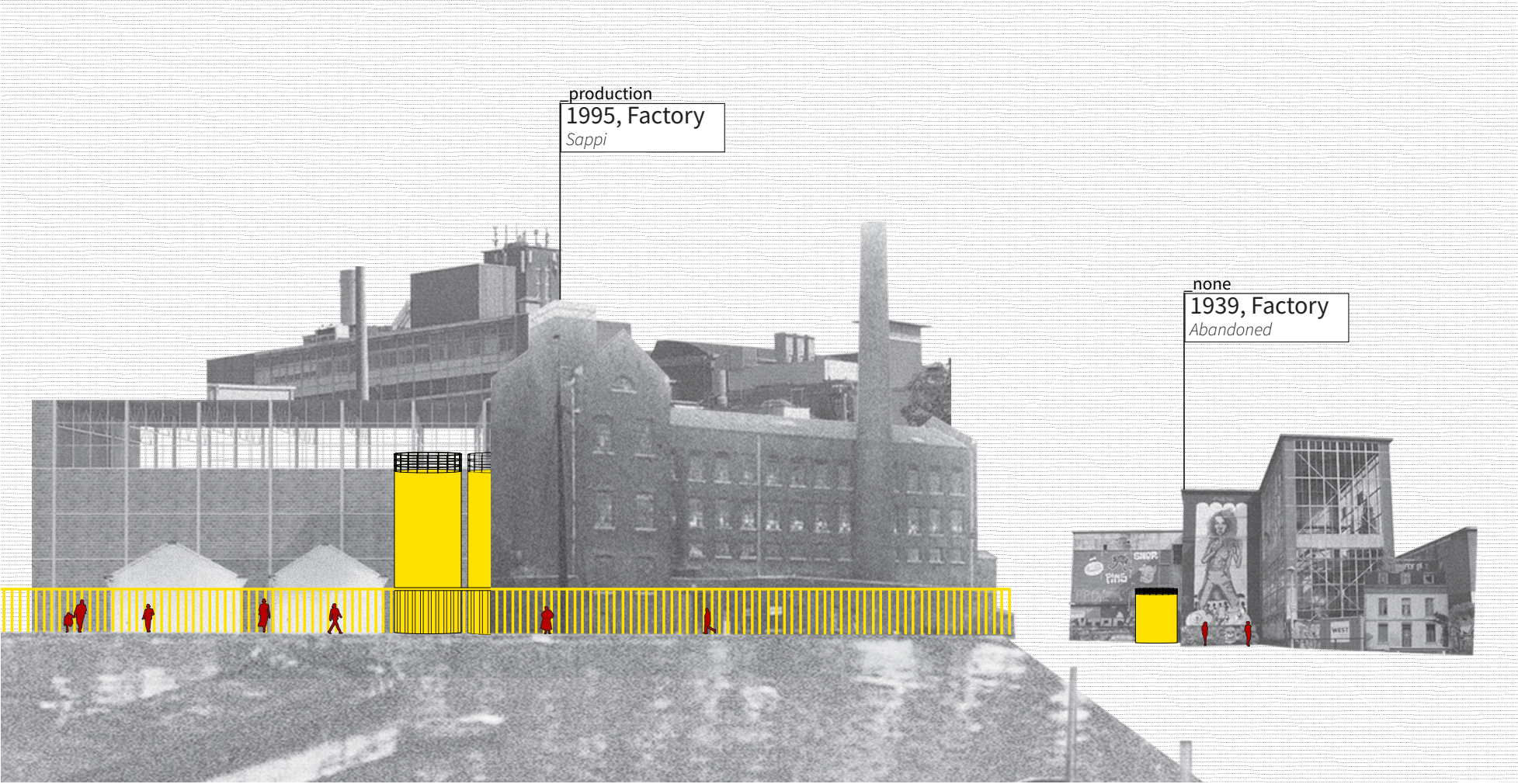

production  
1995, Factory  
*Sappi*

none  
1939, Factory  
*Abandoned*

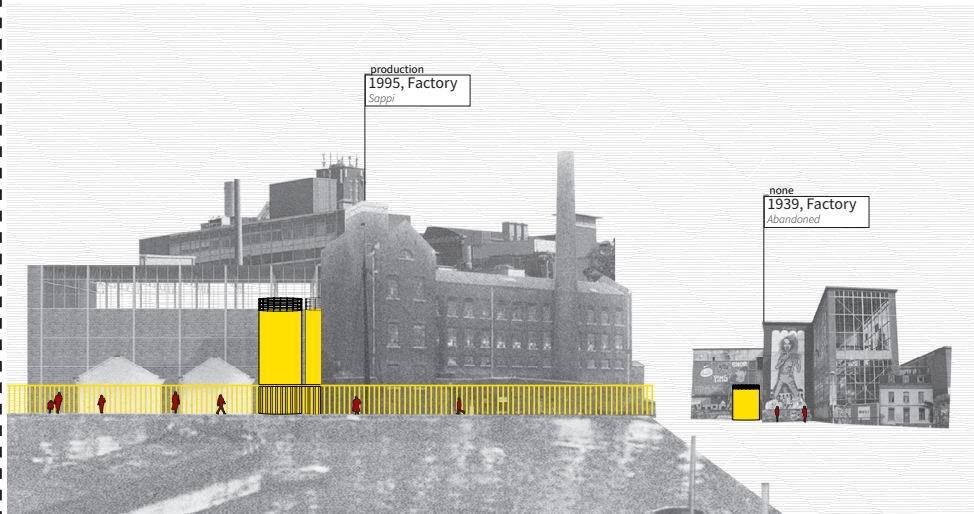

position



Charles Sheeler

**PRODUCTION  
(INDUSTRY)  
NEEDS A  
SECOND  
CHANCE**

Position

26.10.16  
↓  
15.01.17

BO  
ZAR

[ENG]

# A Good City Has Industry



A good city has industry.

We need to close the gap between thinkers and creators.  
The gap between the knowledge and manufacturing economy is also reflected in the space.

Urban industry needs its public visibility and buildings.

Sharing facilities liberates extra space for the urban economy.

Space is a scarce commodity in the city. If companies use facilities and infrastructure together; rather than each in their own property, we will gain space for the urban economy. Shared spaces also add public places and passages to the urban industrial area.

Fostering coalitions between companies allows for maximum use of limited space.

“Workers and residents together are able to produce more than the sum of our two parts”

Jane Jacobs, the Death and Life of Great American Cities



Agnes Varda, *Gleaners and I*

How do we glean non-human scale industrial legacy/  
production to use it as a prime catalyst in the integration  
of the urban site?

transformations

**CITY**

transformations  
1:1000

**INDUSTRY**



Leon Vöckler, Maastricht 2021

MAASTRICHT



Vineet Dhali, Maastricht 2021

INDUSTRY



MAASTRICHT

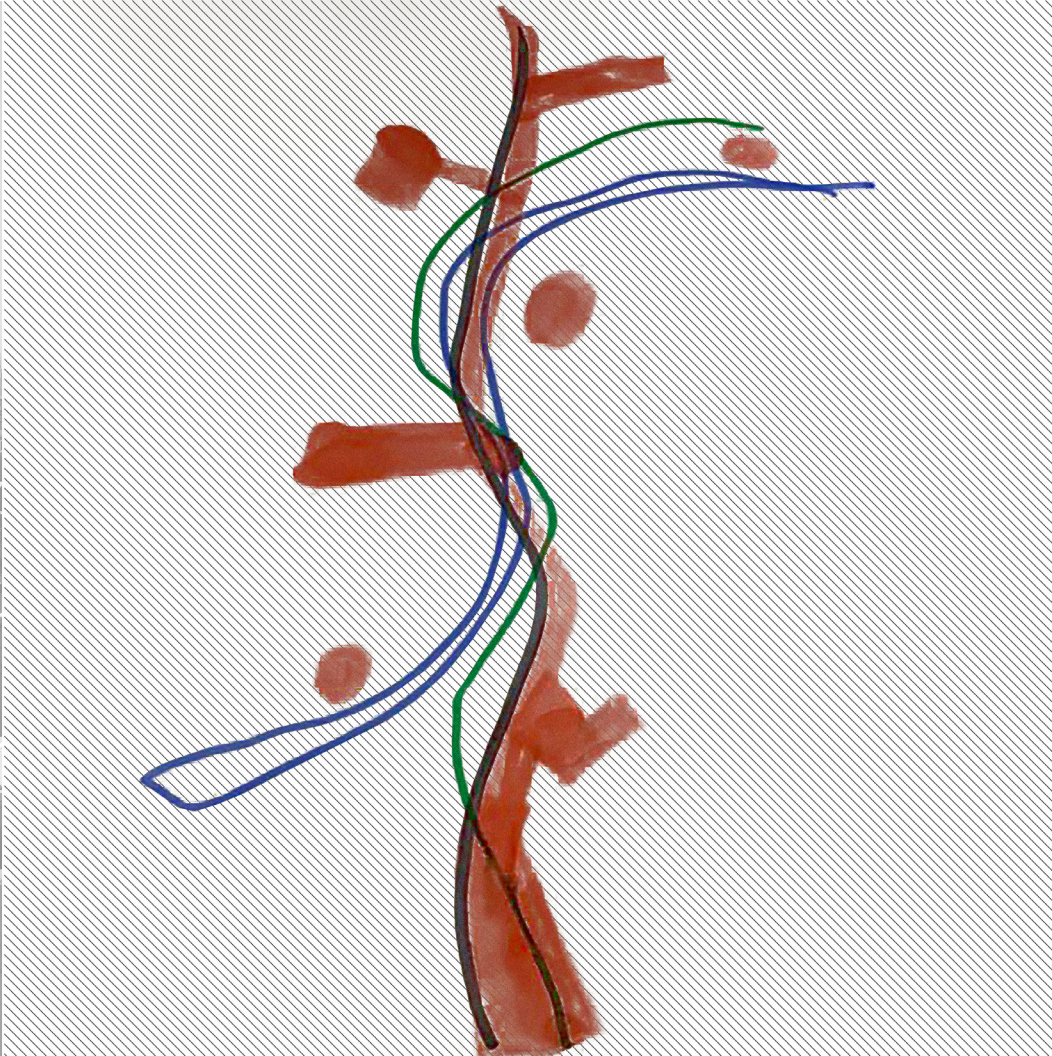

INDUSTRY

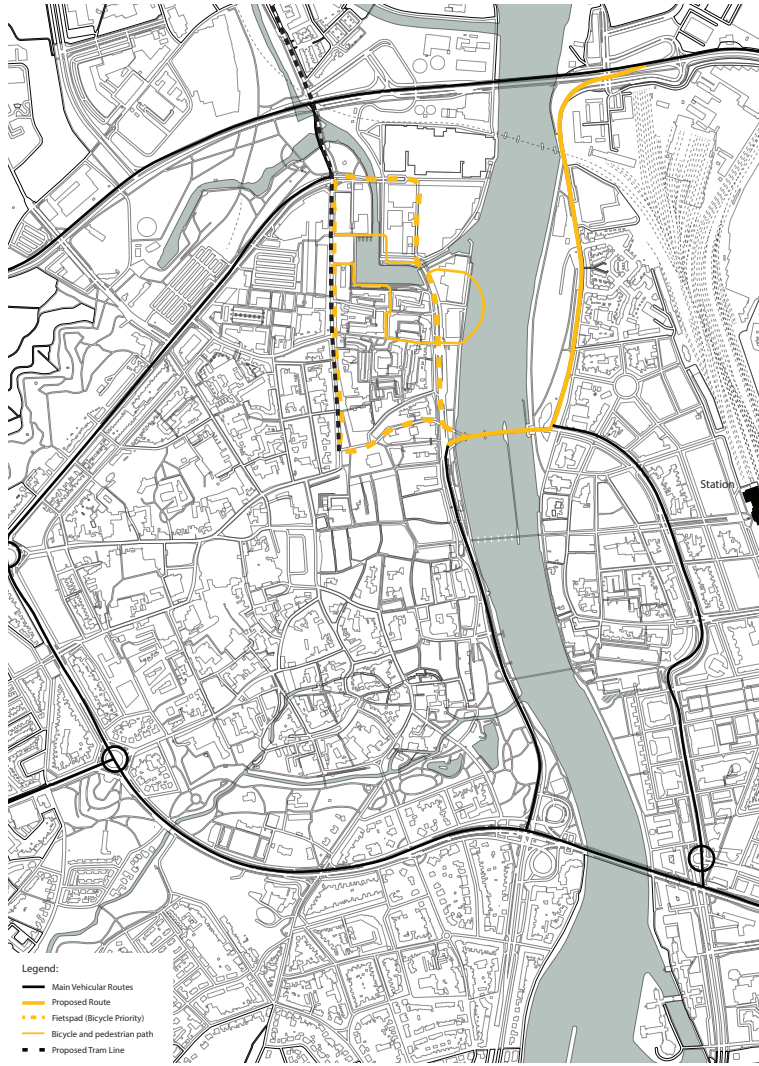

mobility map

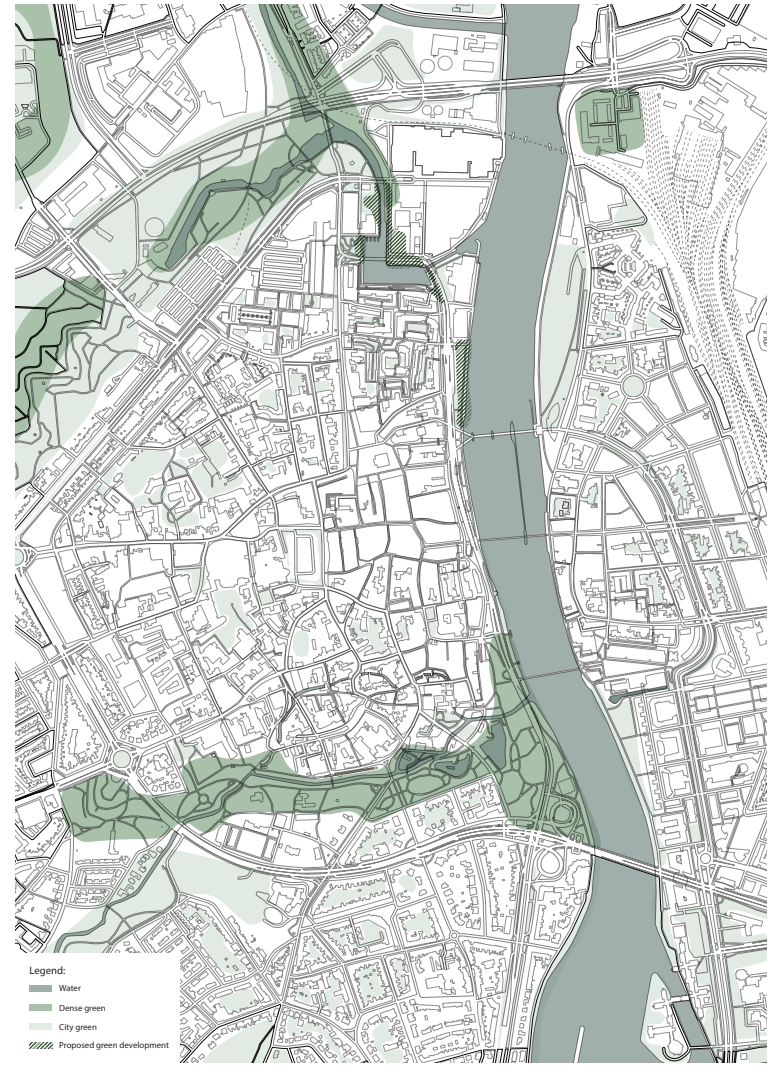

ecology map

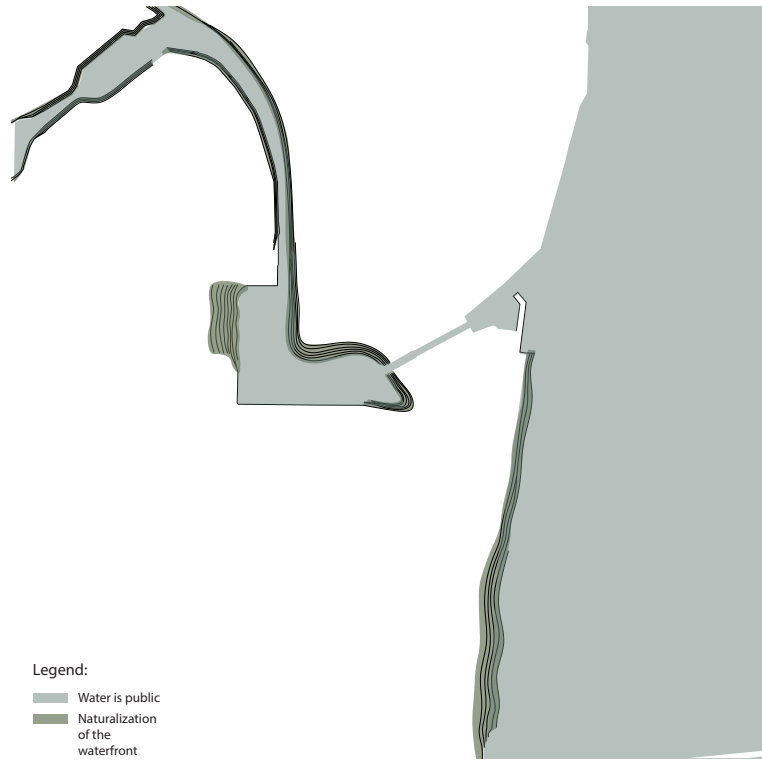

WATER IS PUBLIC

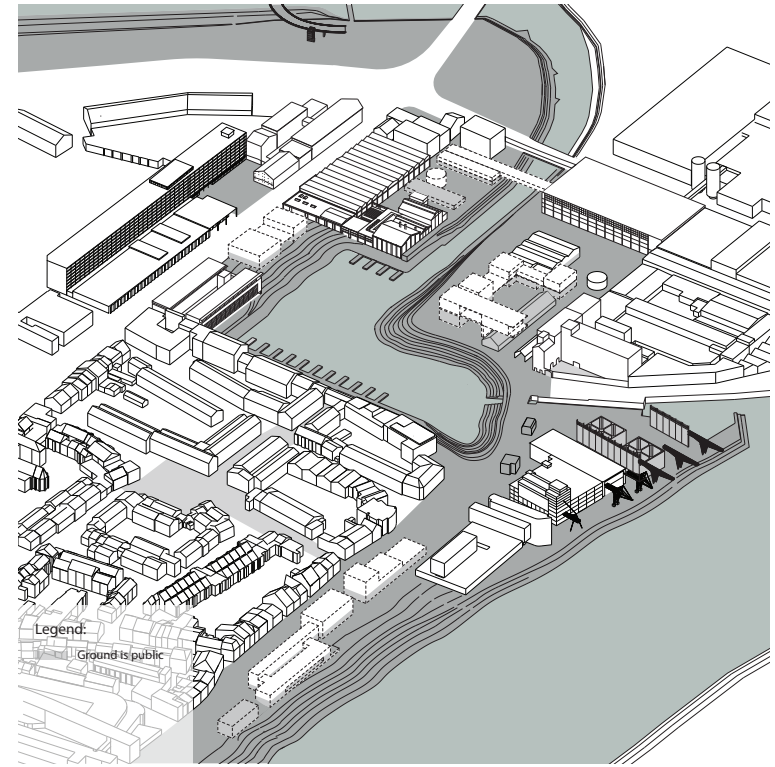

GROUND IS PUBLIC

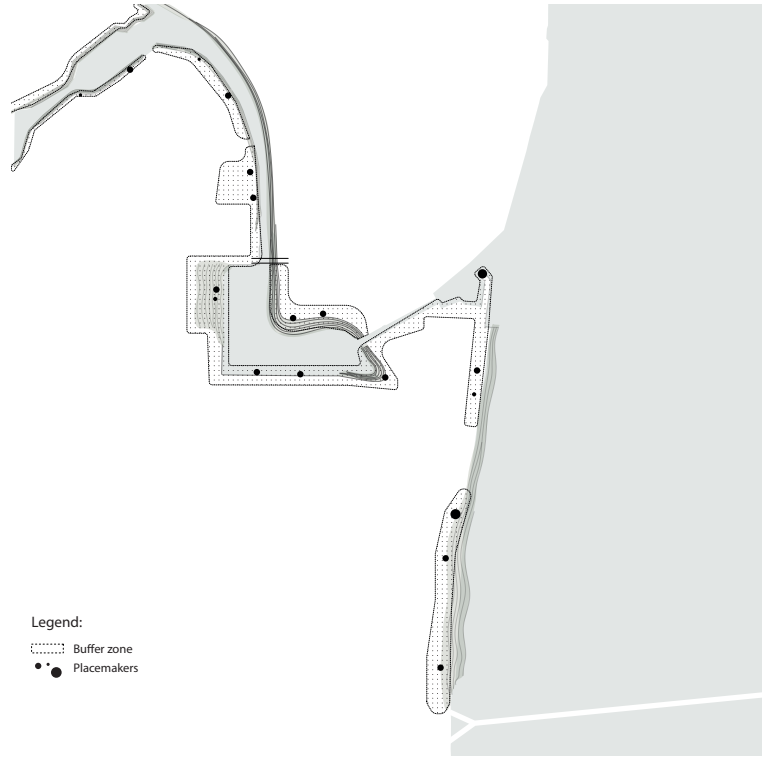

PLACEMAKERS

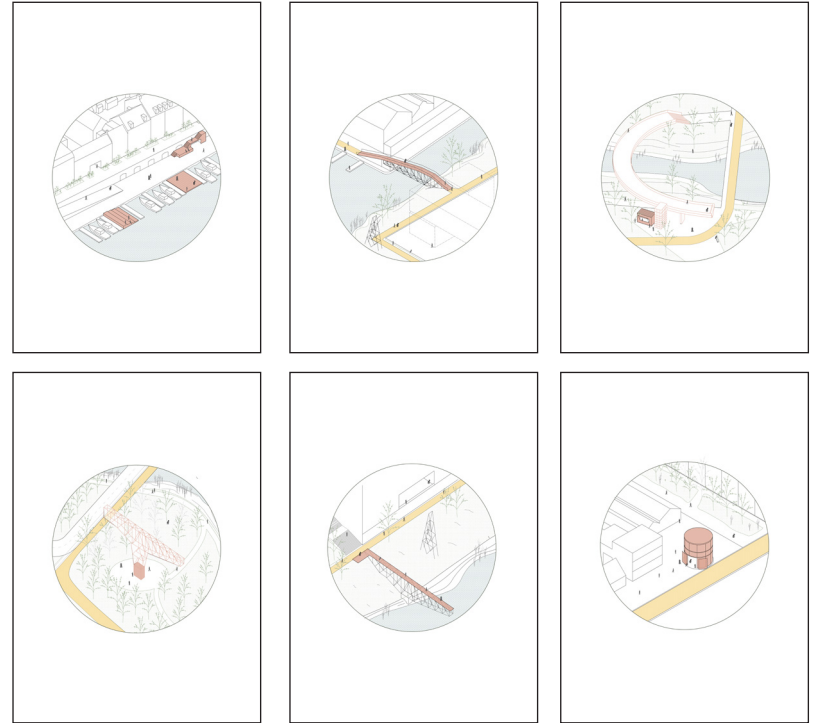



Legend:

- - - - - Demolition
- Dwelling
- Culture
- Production
- /// Mixed-use

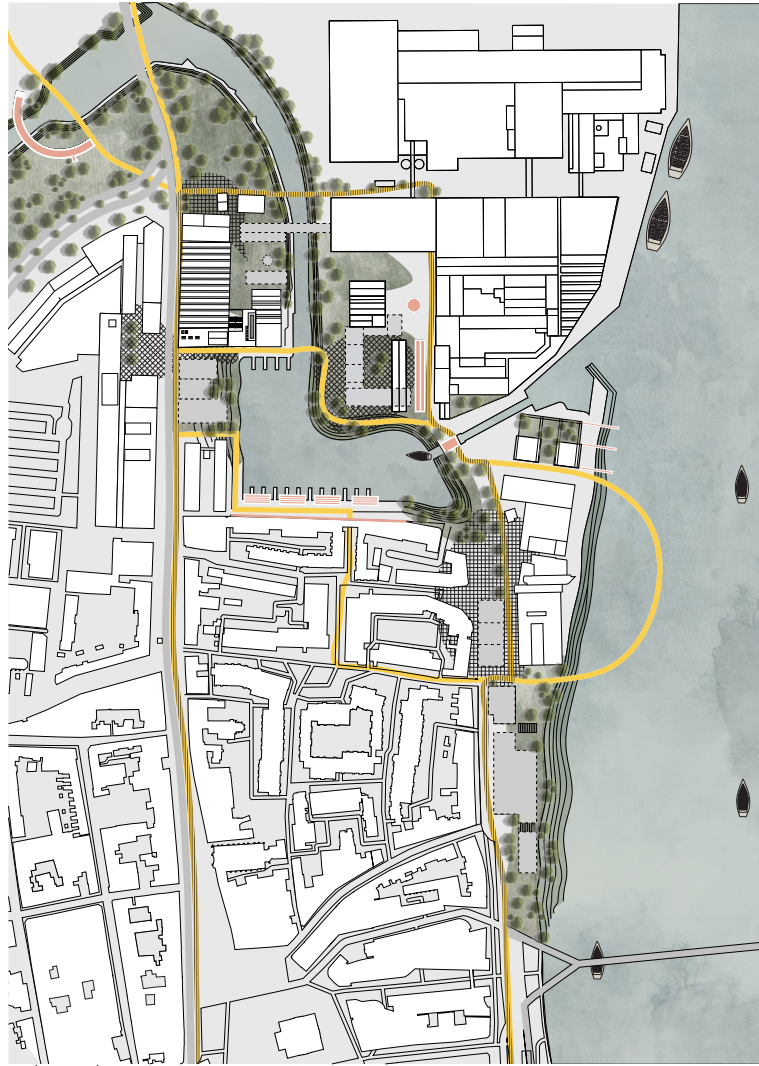

Urban Plan

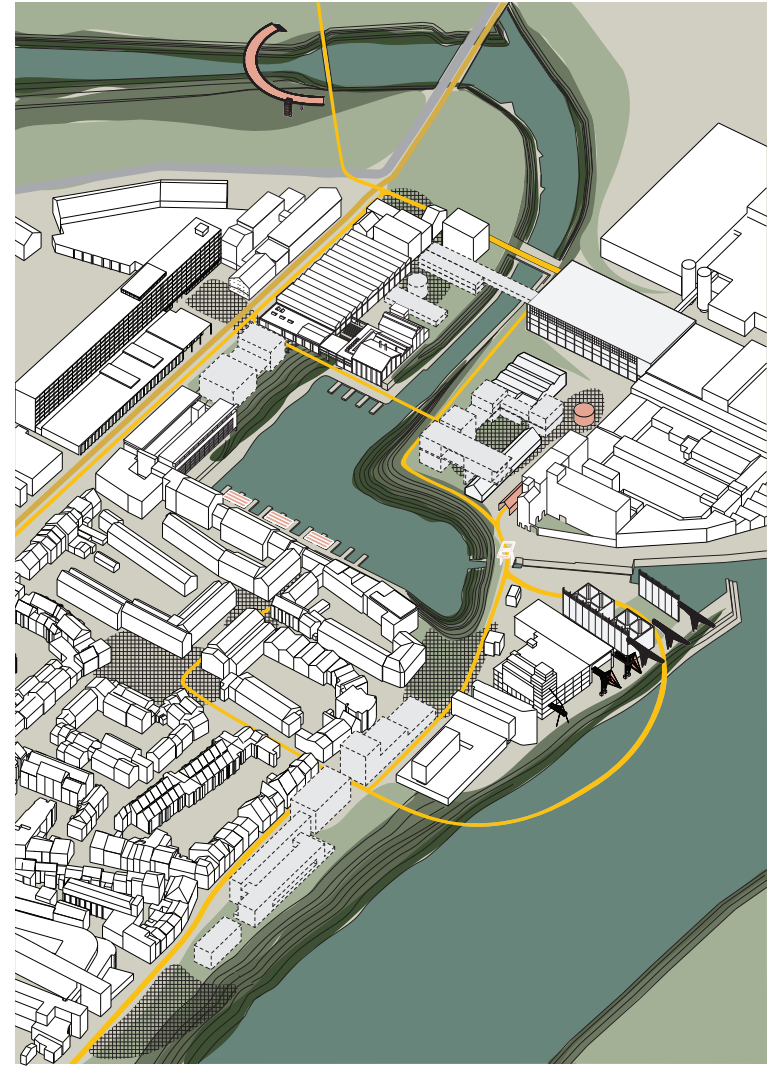

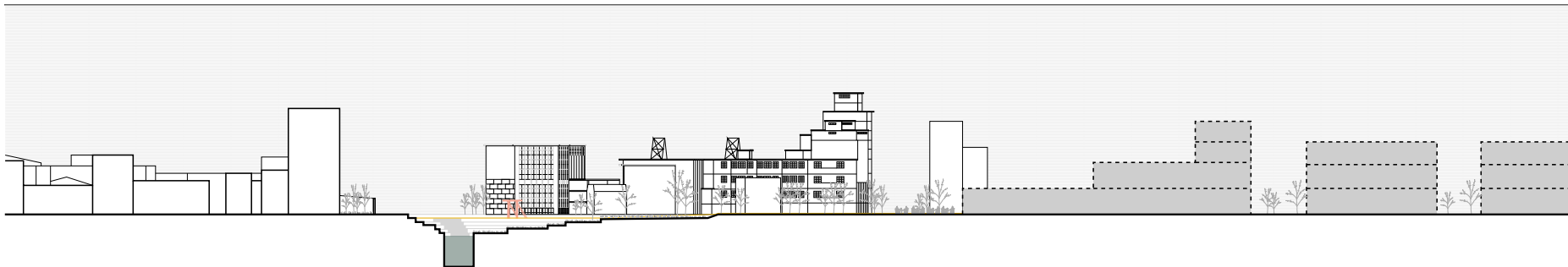
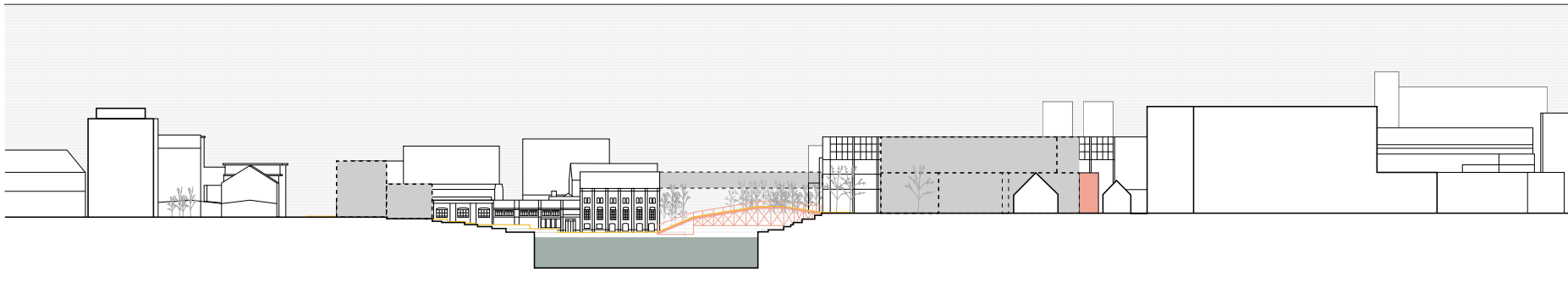
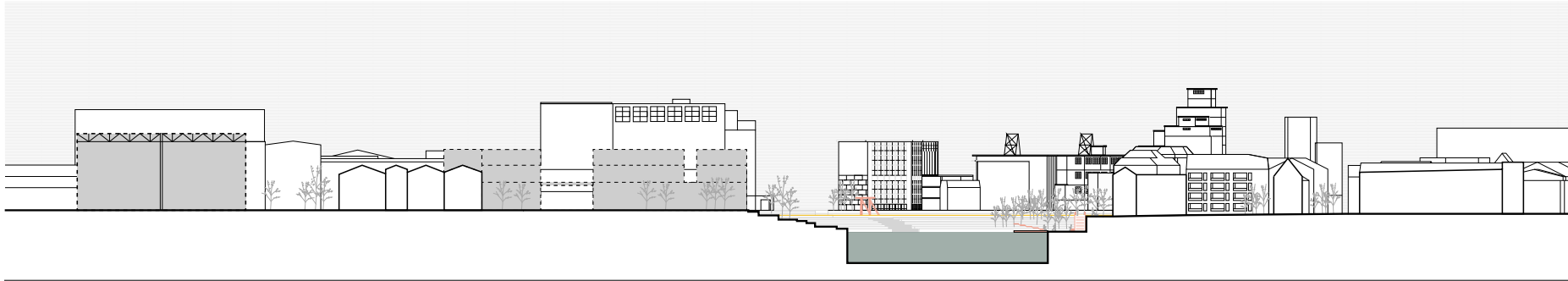





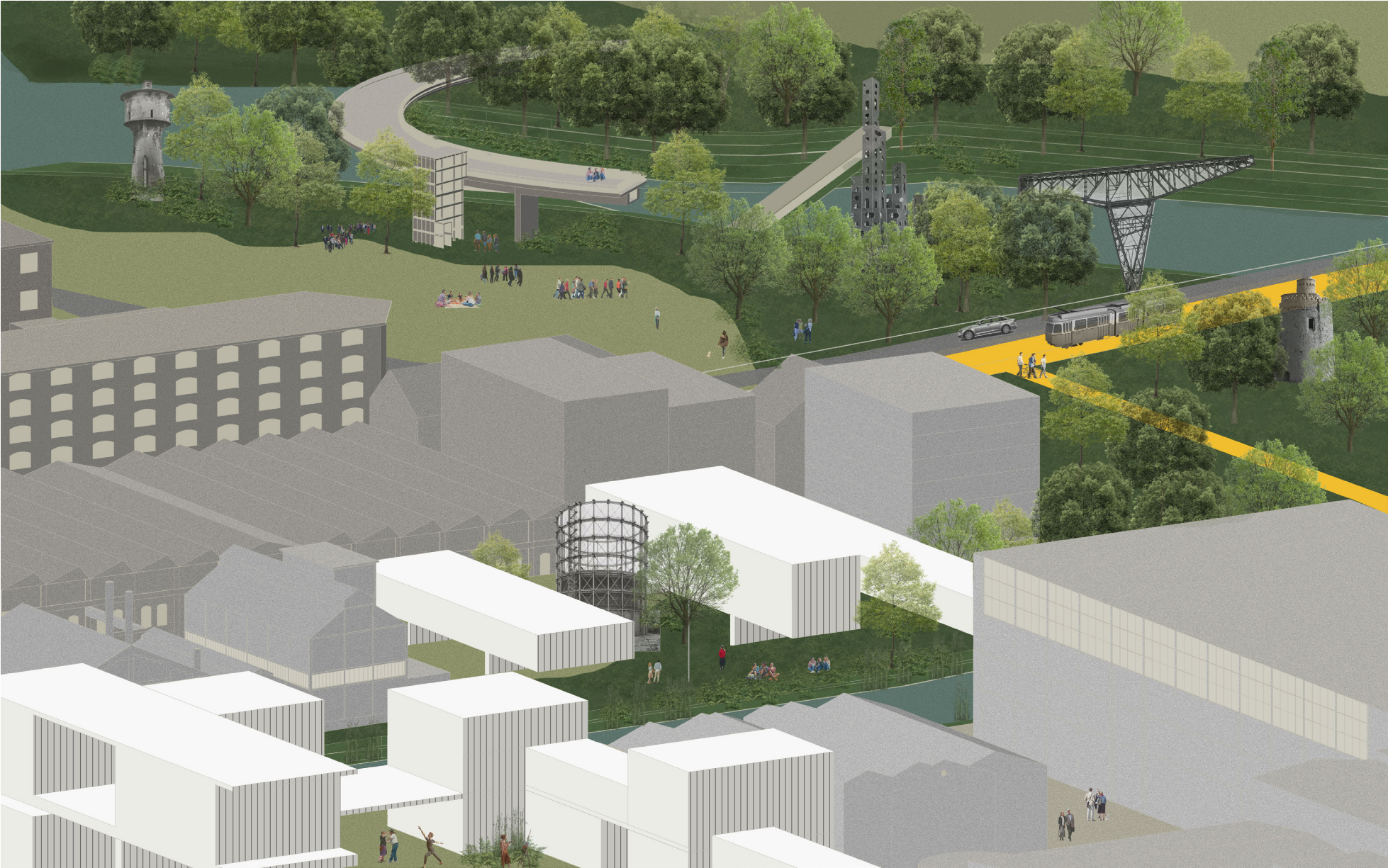

transformations

1:500

**URBAN CONTEXT**

transformations

1:500

**FACTORY**

Antigentrification  
Everyday functions  
Flow based function



**Position:**  
Industry should a part of  
the city  
Atelier Brussels Productive Metropolis

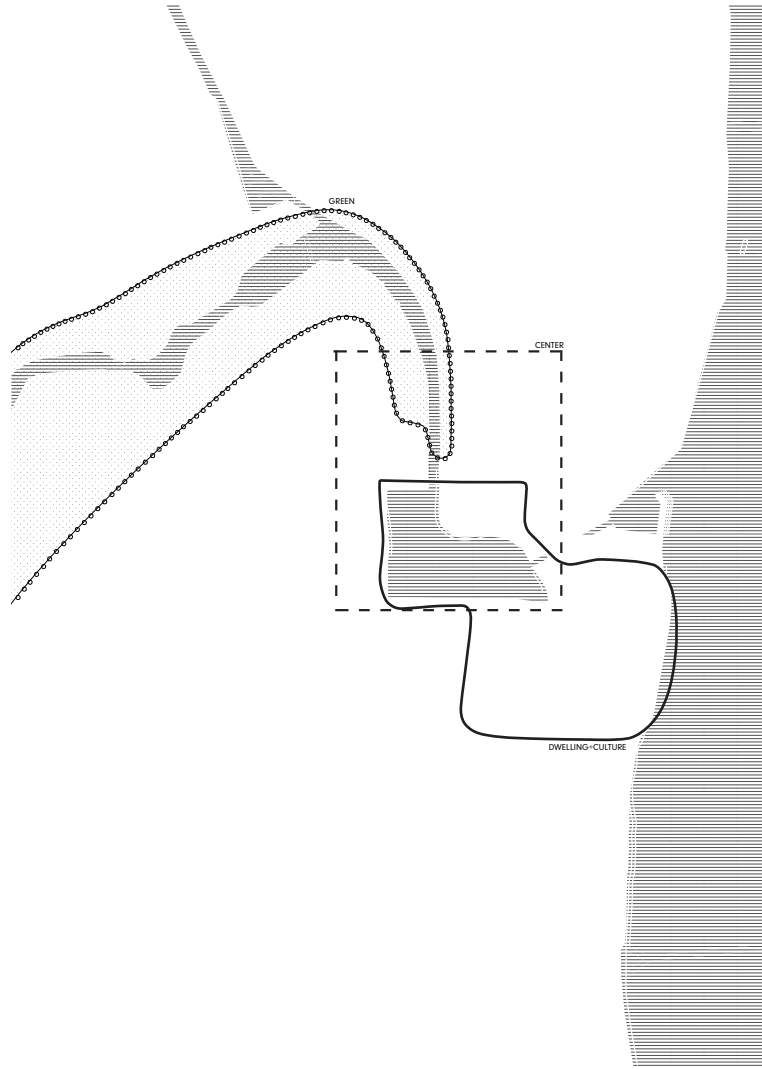

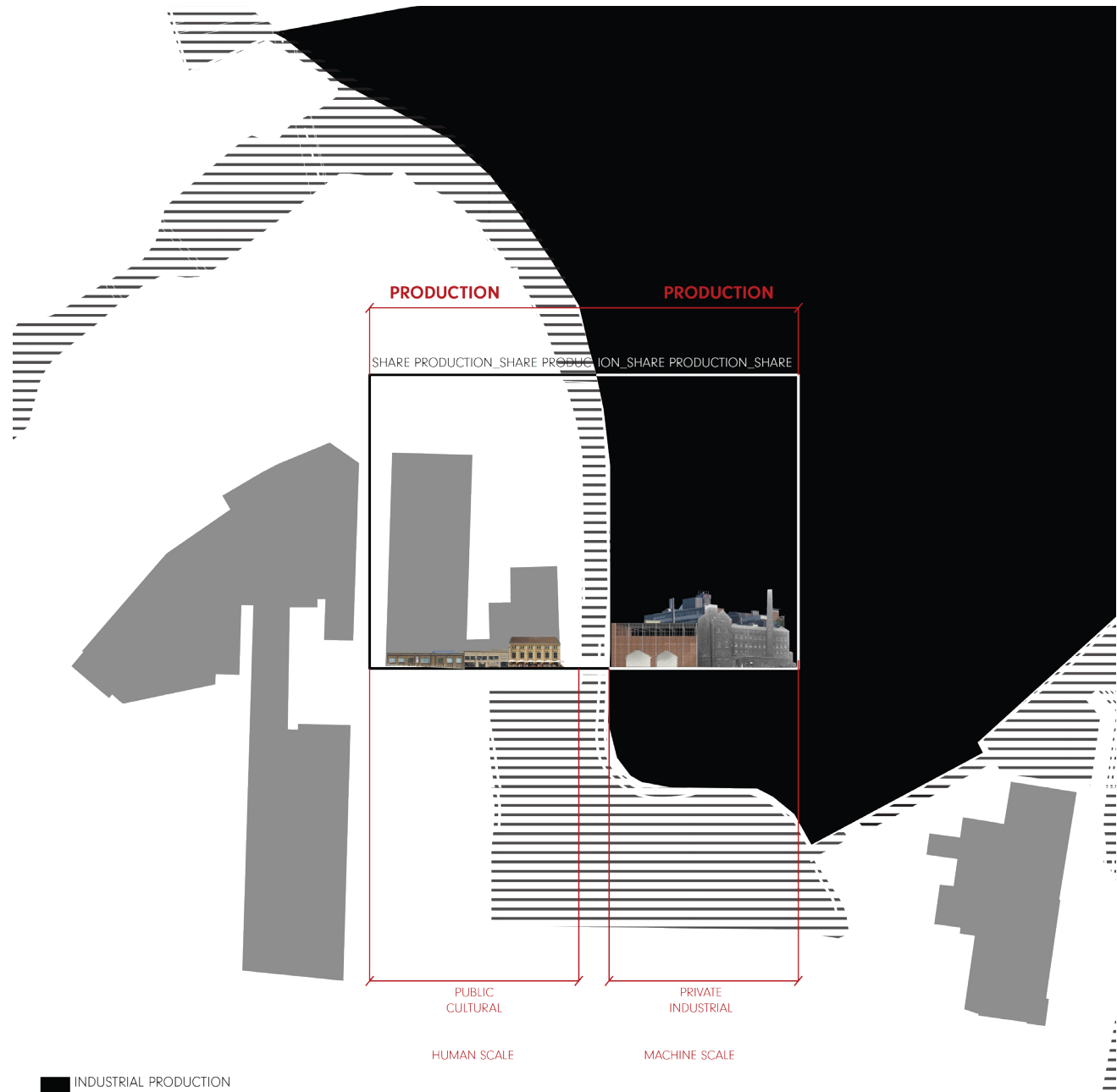

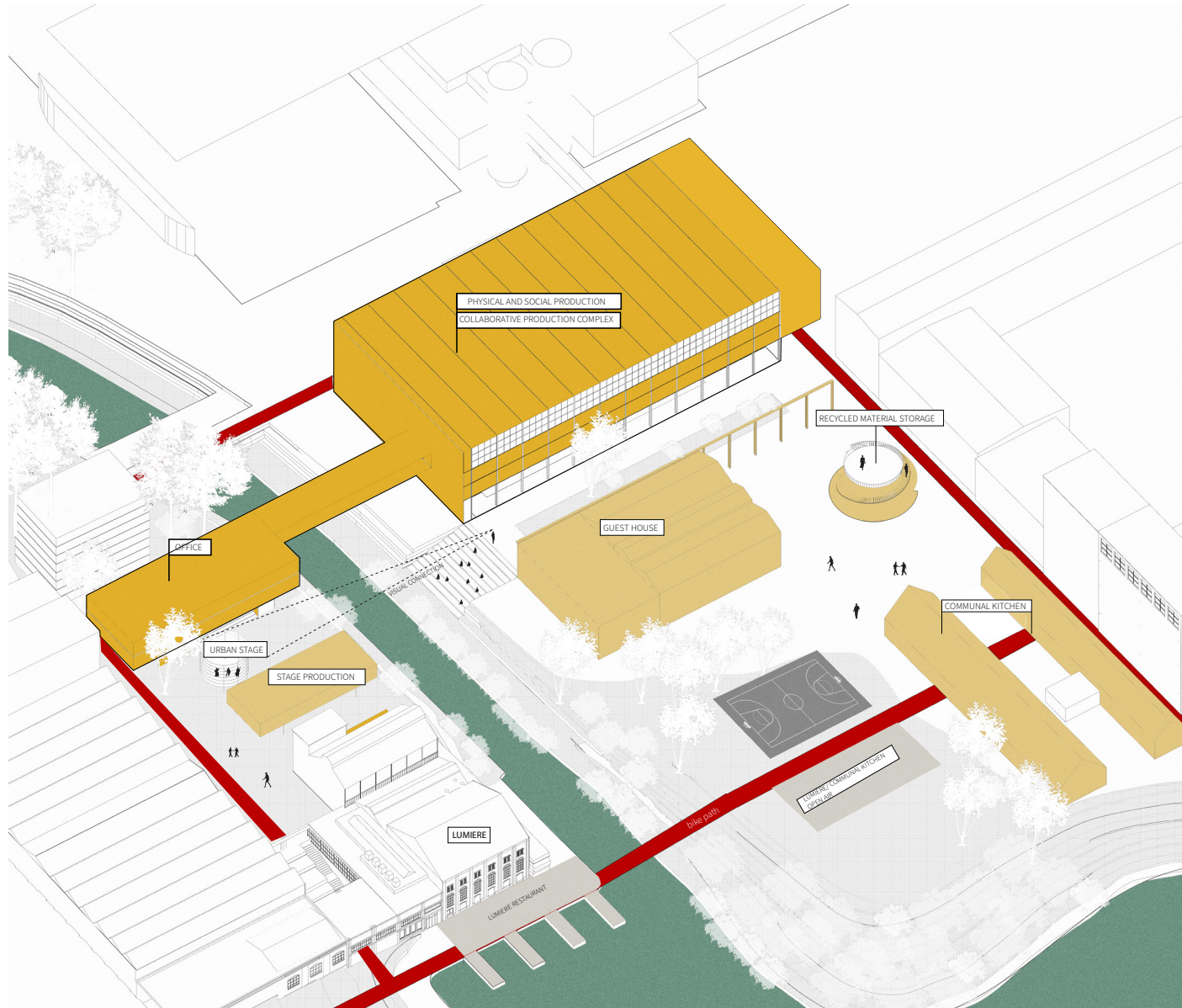

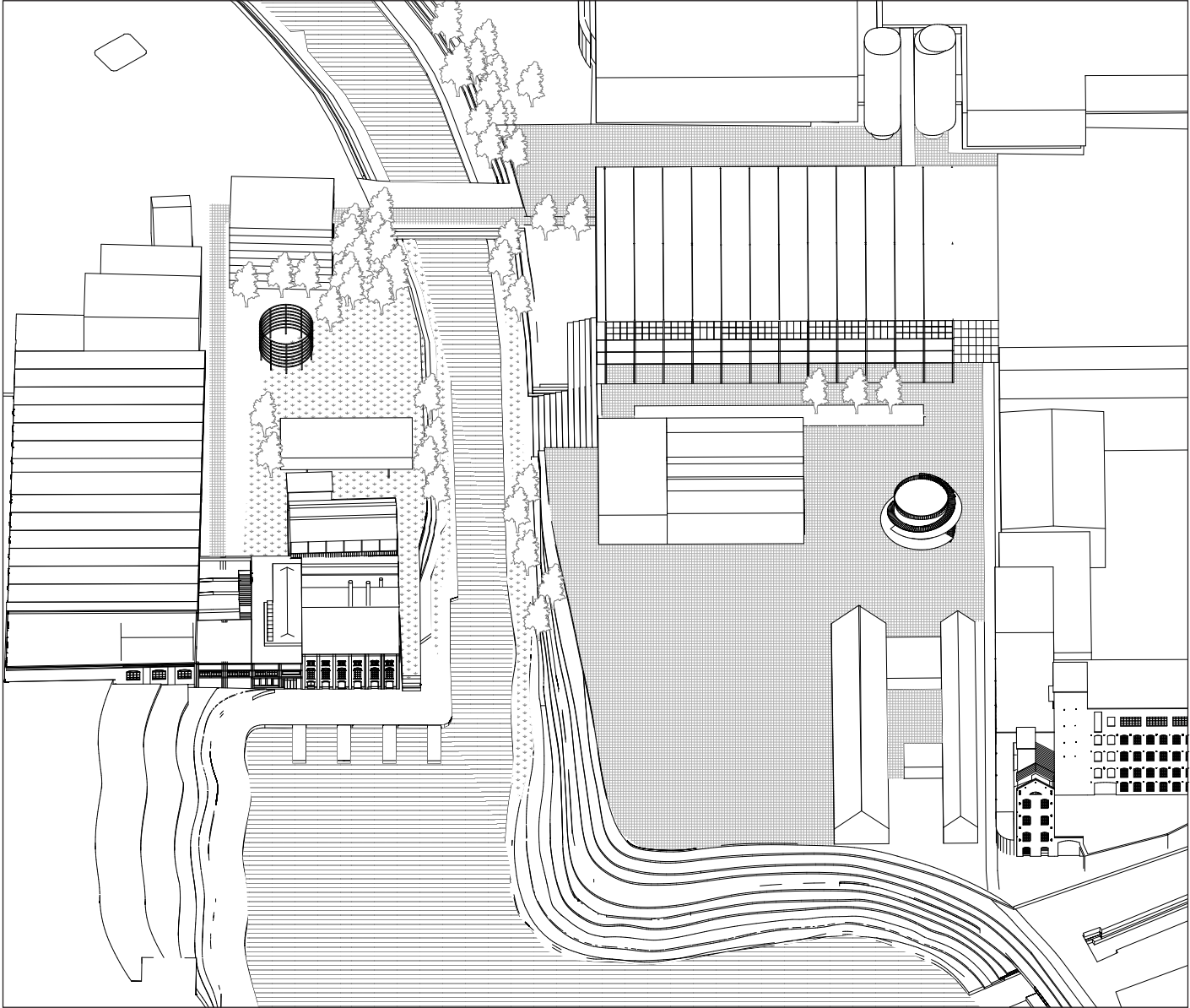

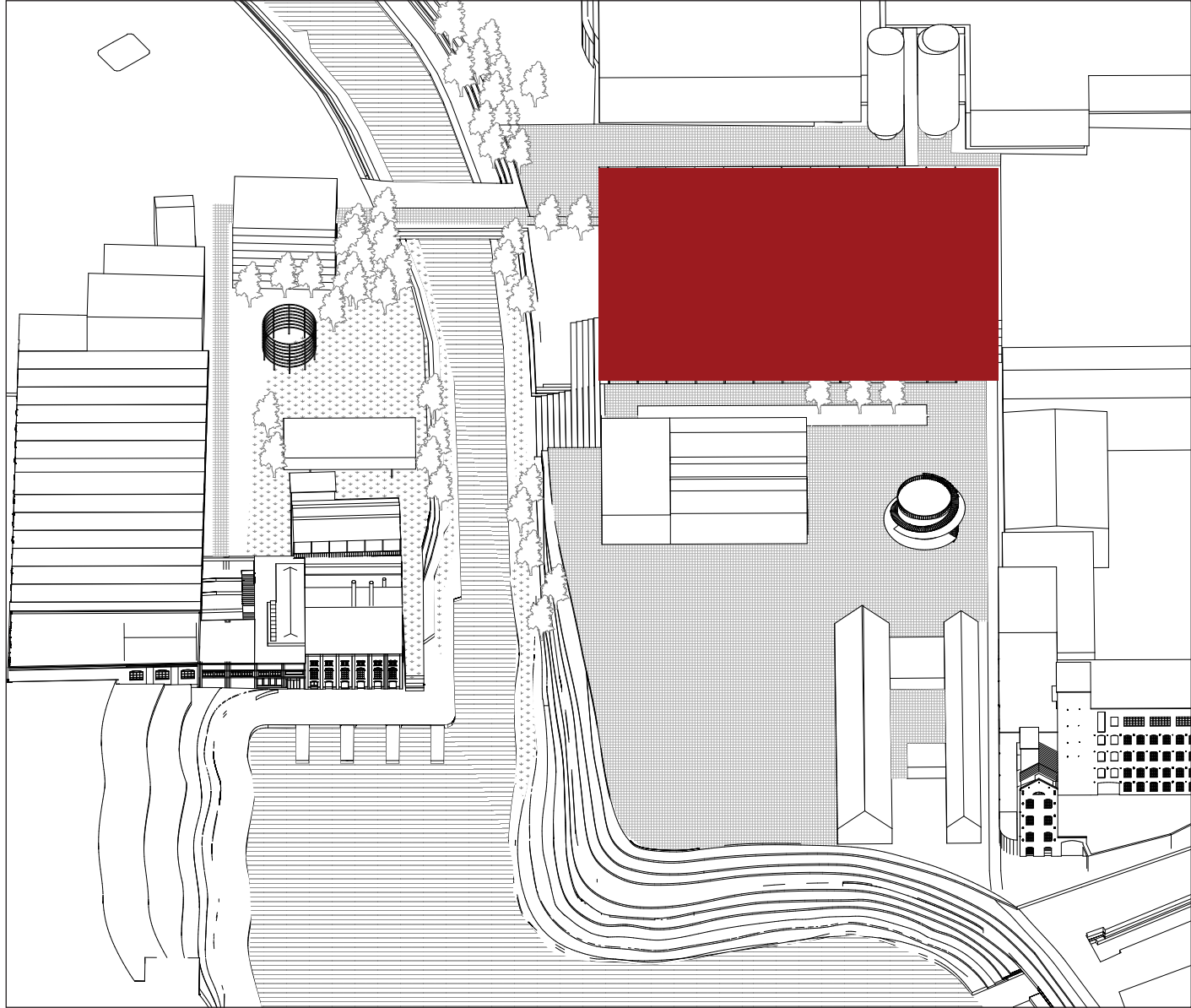

transformations

1:200

**USERS**

transformations

1:200

**PRODUCTION**

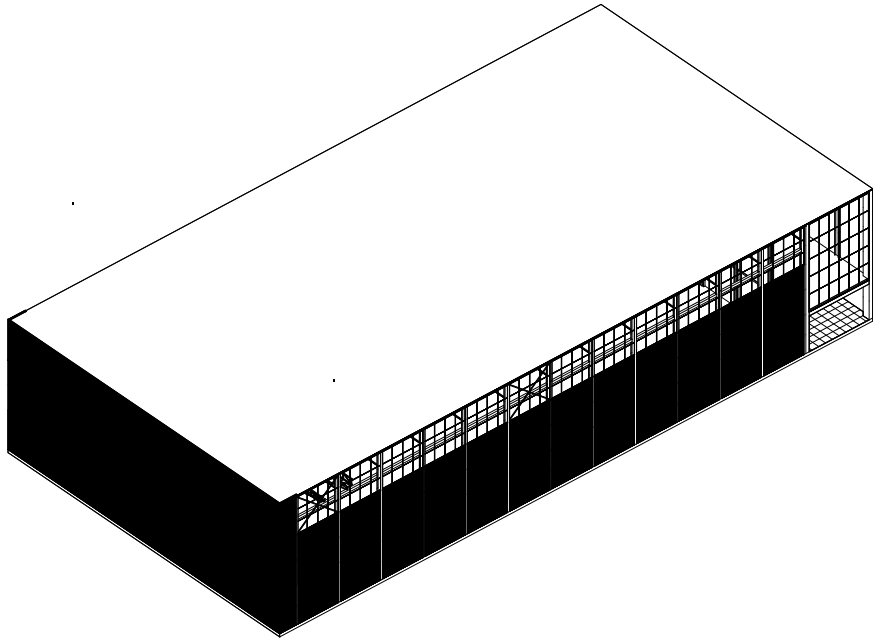

existing building







intention

“Like small manufacturers, these small enterprises would not exist somewhere else, in the absence of cities. Without cities, they would not exist.”

Jane Jacobs, *The Death and Life of Great American Cities*

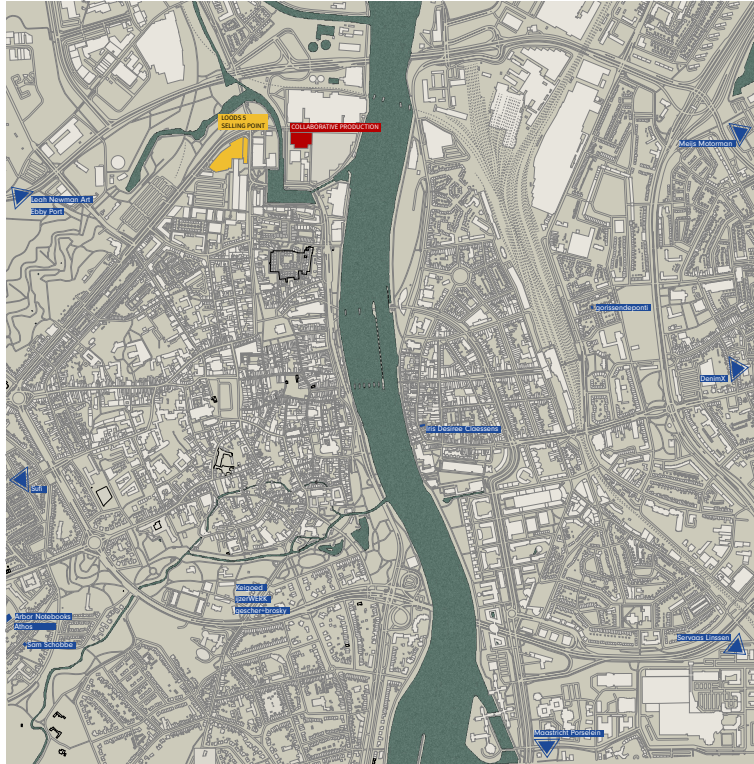

Makers of Maastricht

“Like small manufacturers, these small enterprises would not exist somewhere else, in the absence of cities. Without cities, they would not exist.”

Jane Jacobs, the Death and Life of Great American Cities





### Research in Design Questions

How do we find the human environment within the machine environment to create an urban flow? How does production become the common ground in different scales to evoke urban interaction?

What is a human environment? What is a machine environment? How does the human scale spatially encounter with the machine scale?

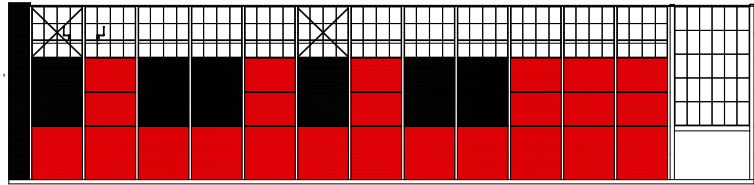
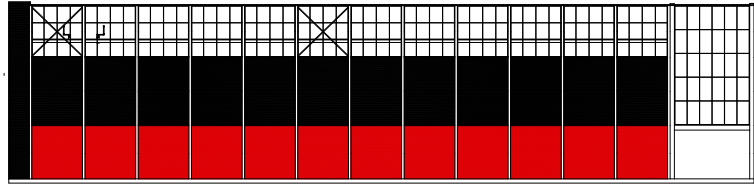



transformations

1:1000

**HUMAN**

transformations

1:1000

**MACHINE**

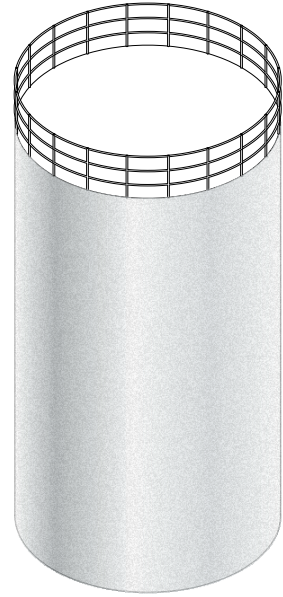
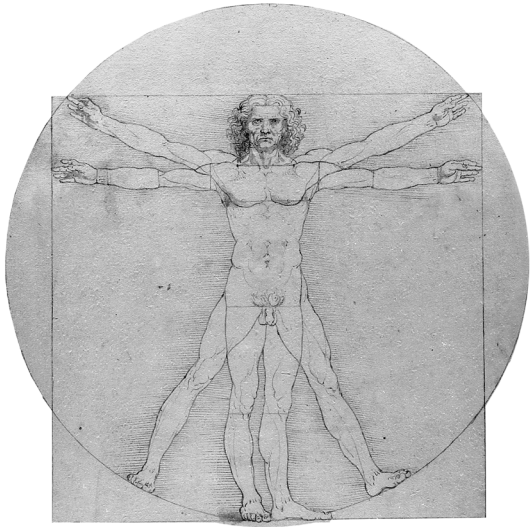

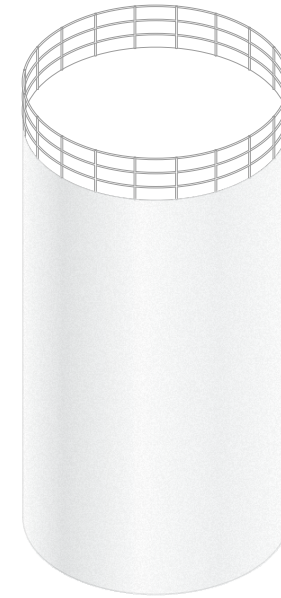
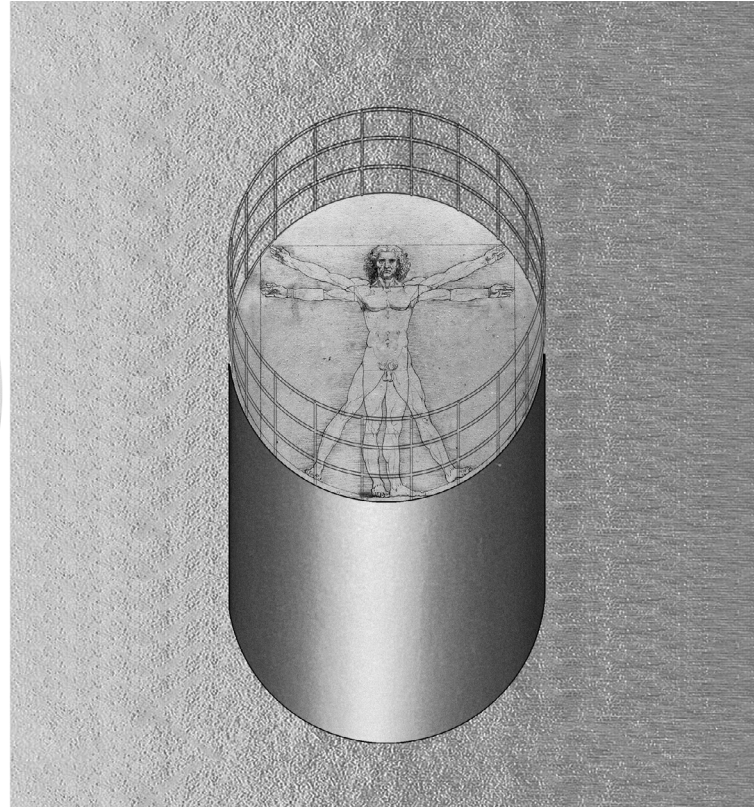
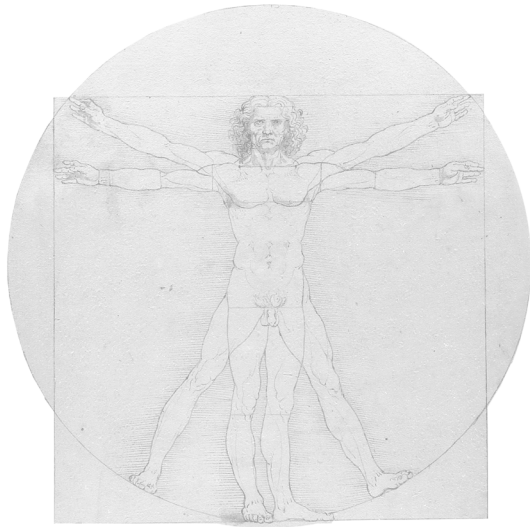

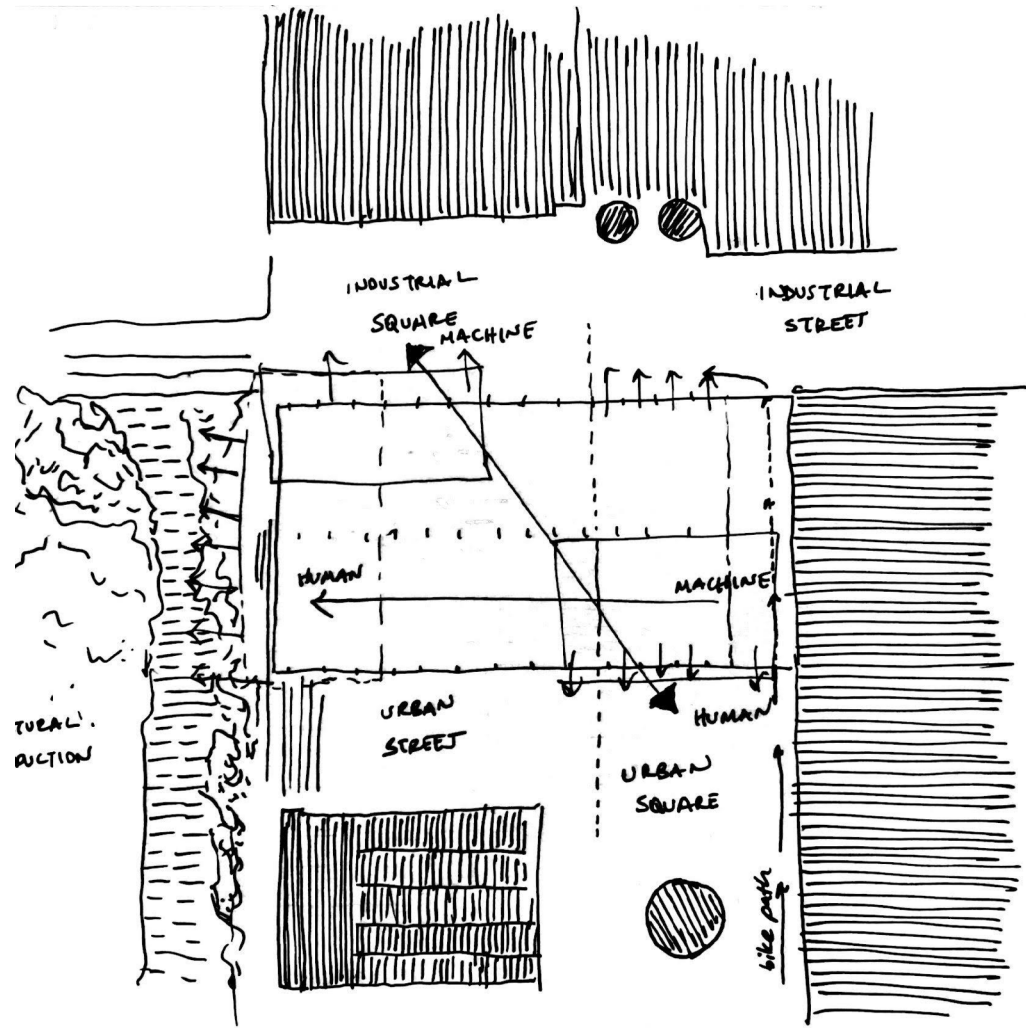

reading the context

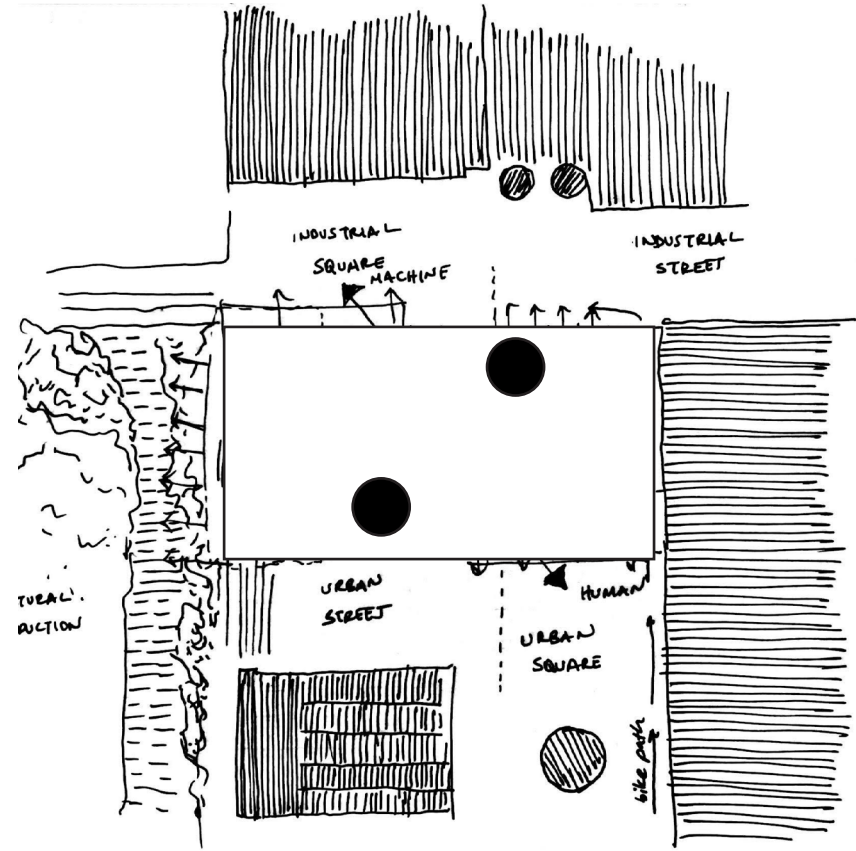
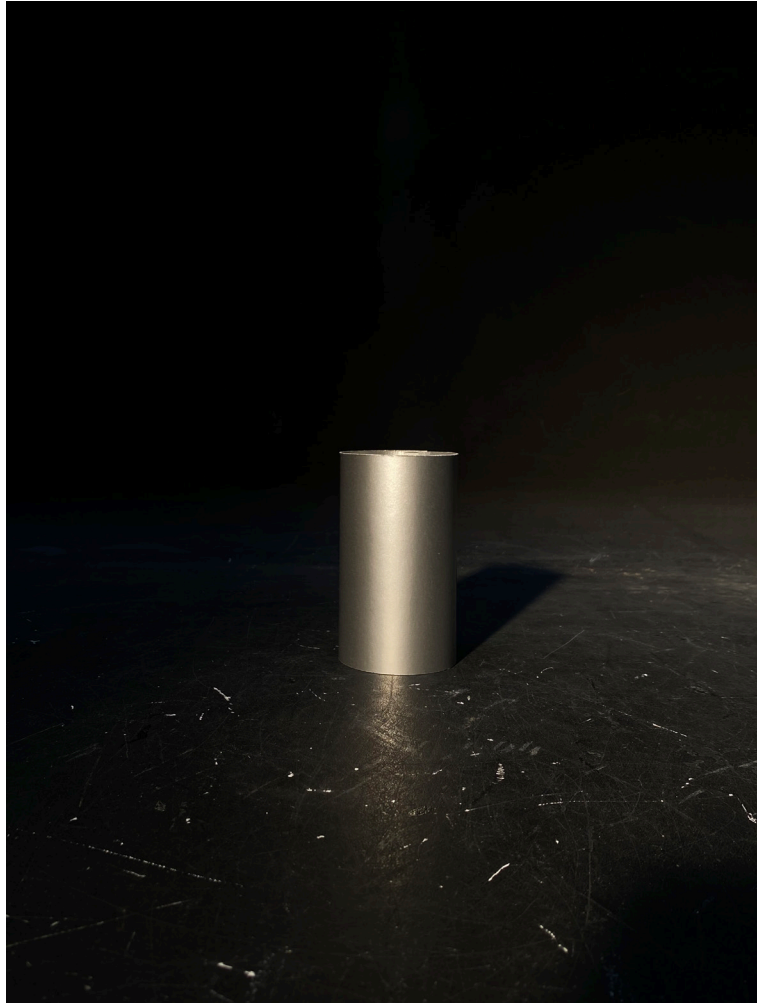

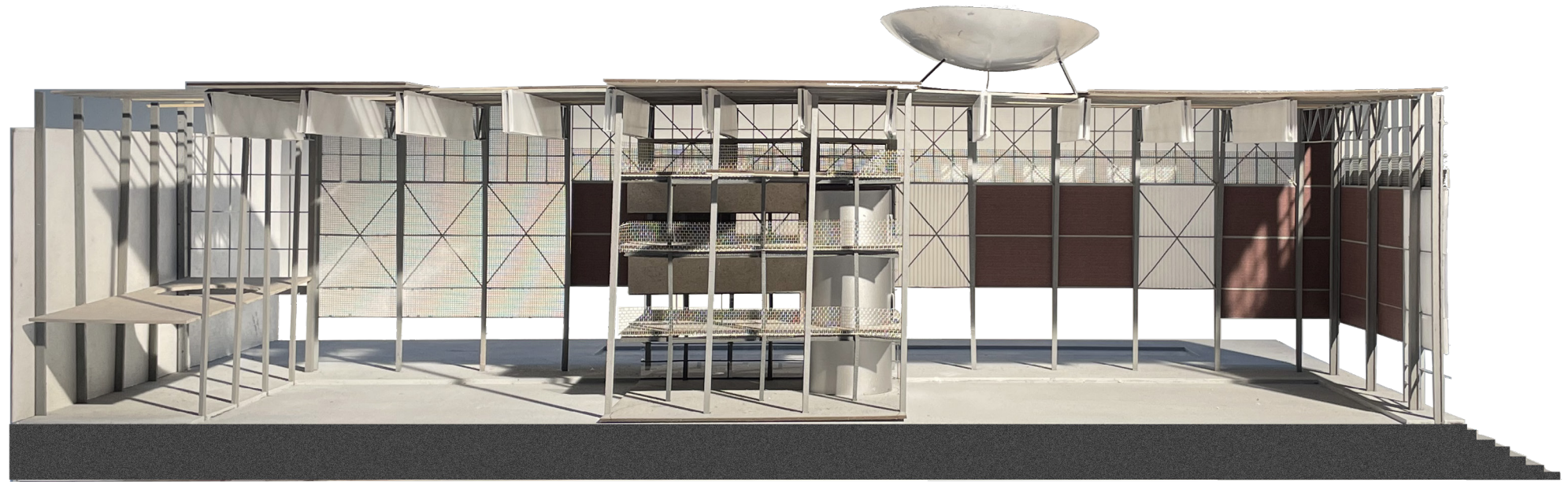

object

circulation analysis

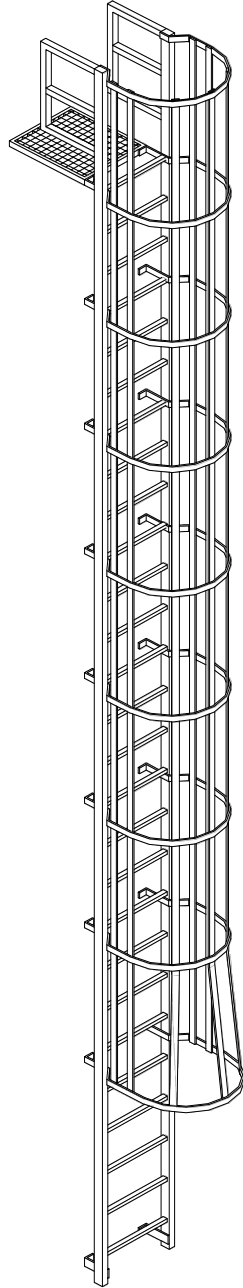

circulation  
analysis

Human movement  
in the factory  
and non-human  
production spaces  
are observed to  
be vertical: either  
point circulation  
or extremely steep  
staircases.



Sappi Factory

transformation

circulation core

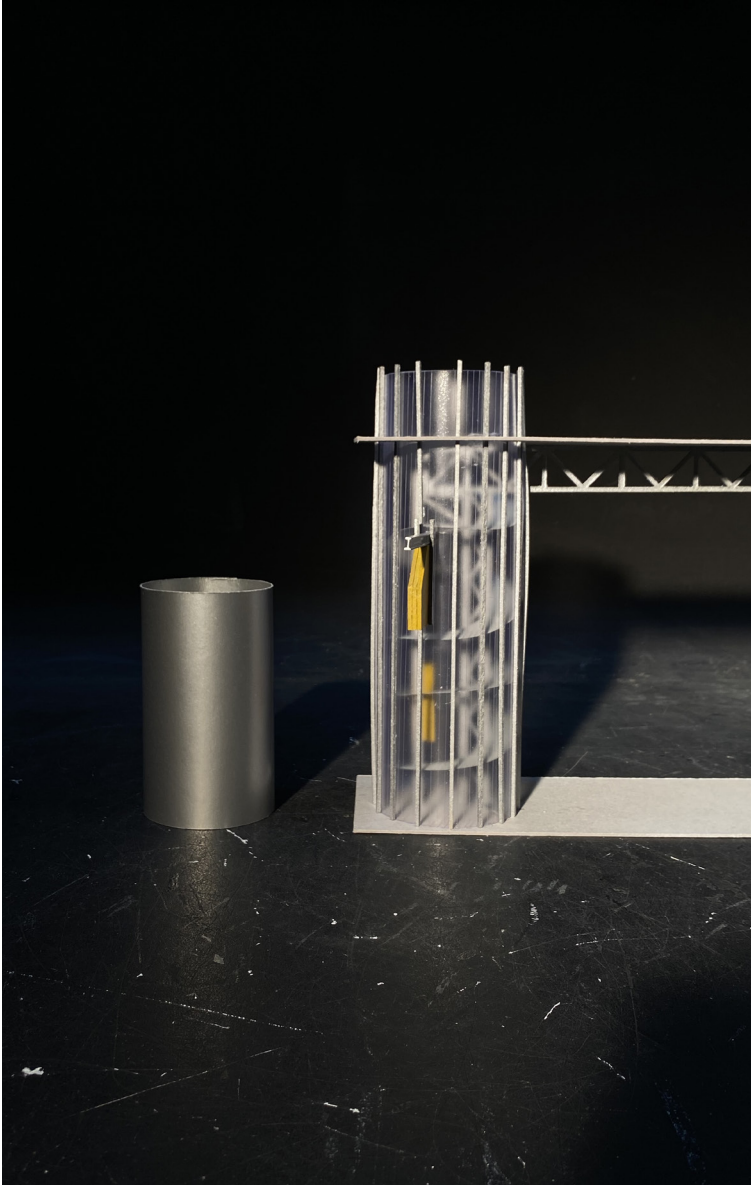
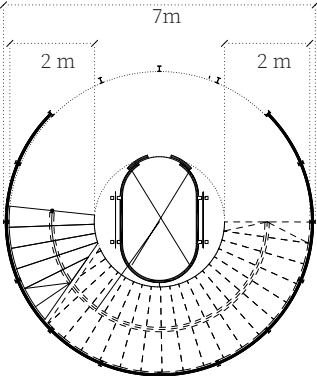
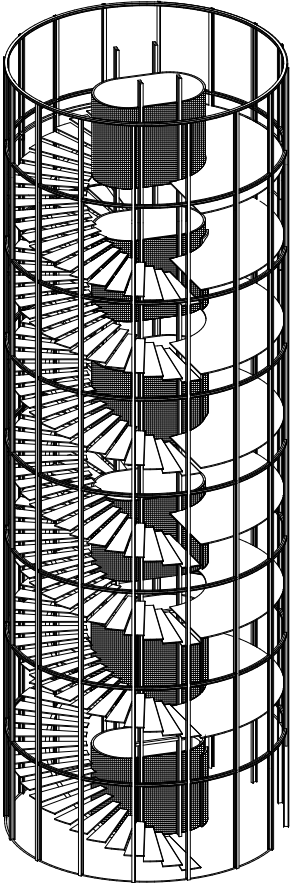

Study Model

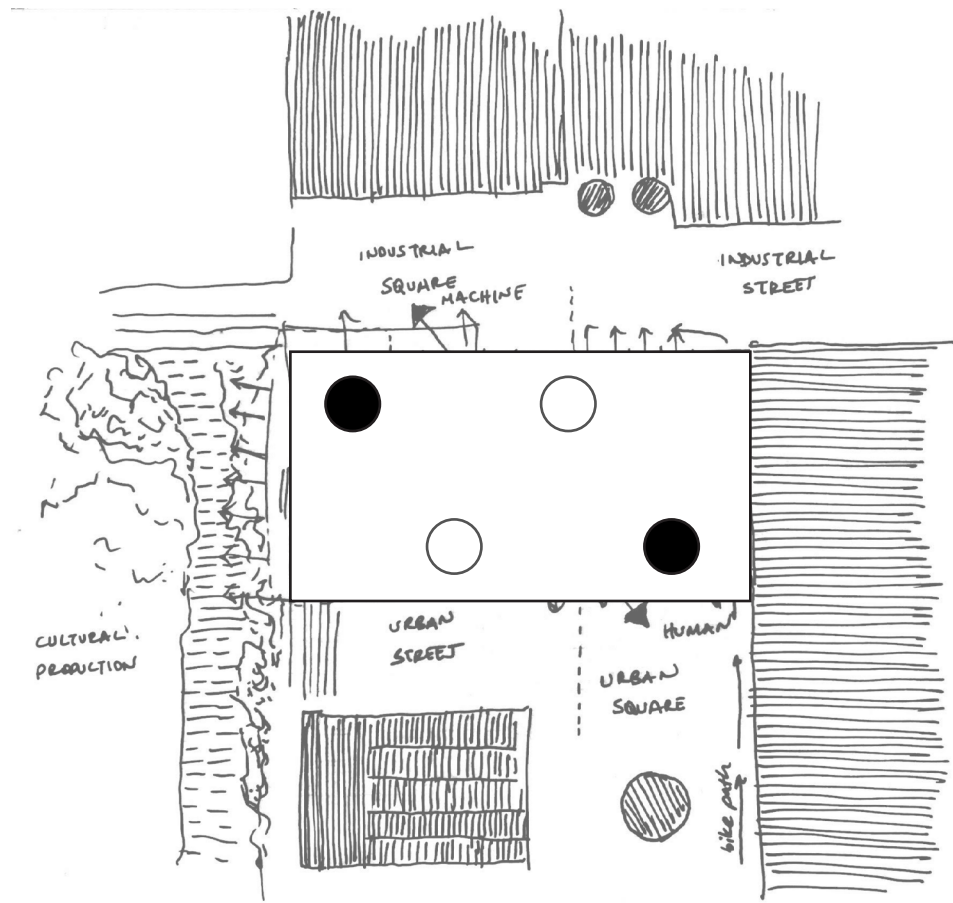

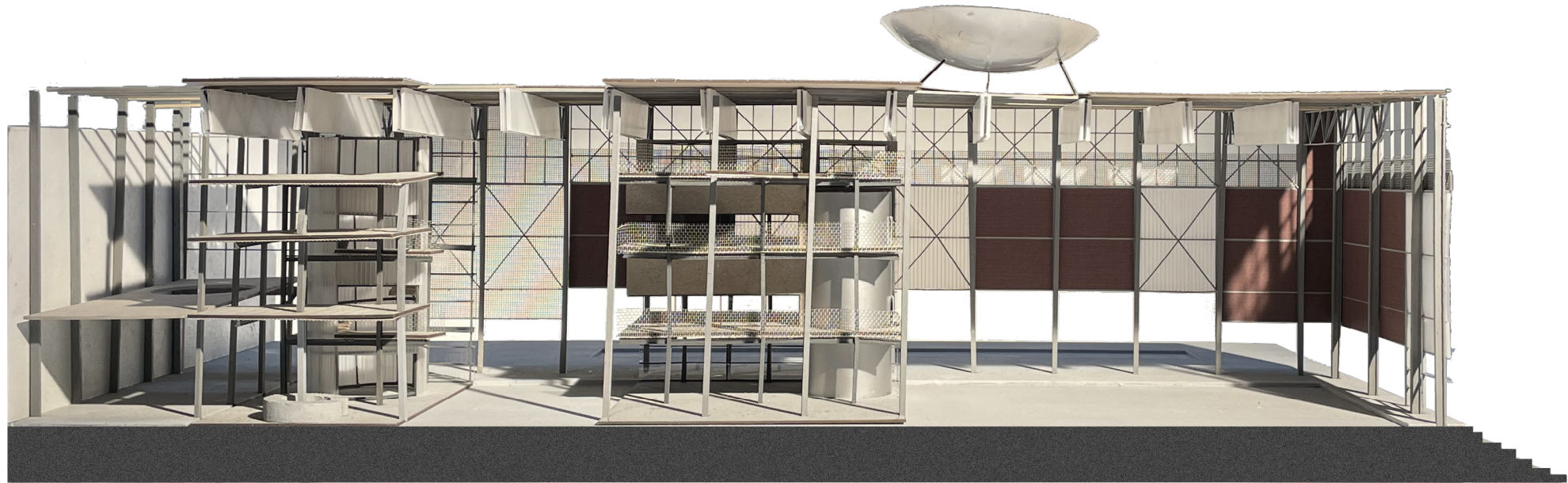

object

silo

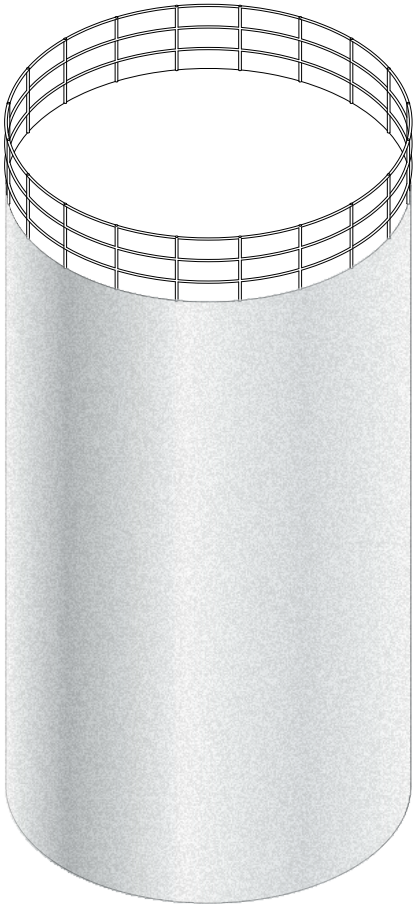

## transformation

shaft

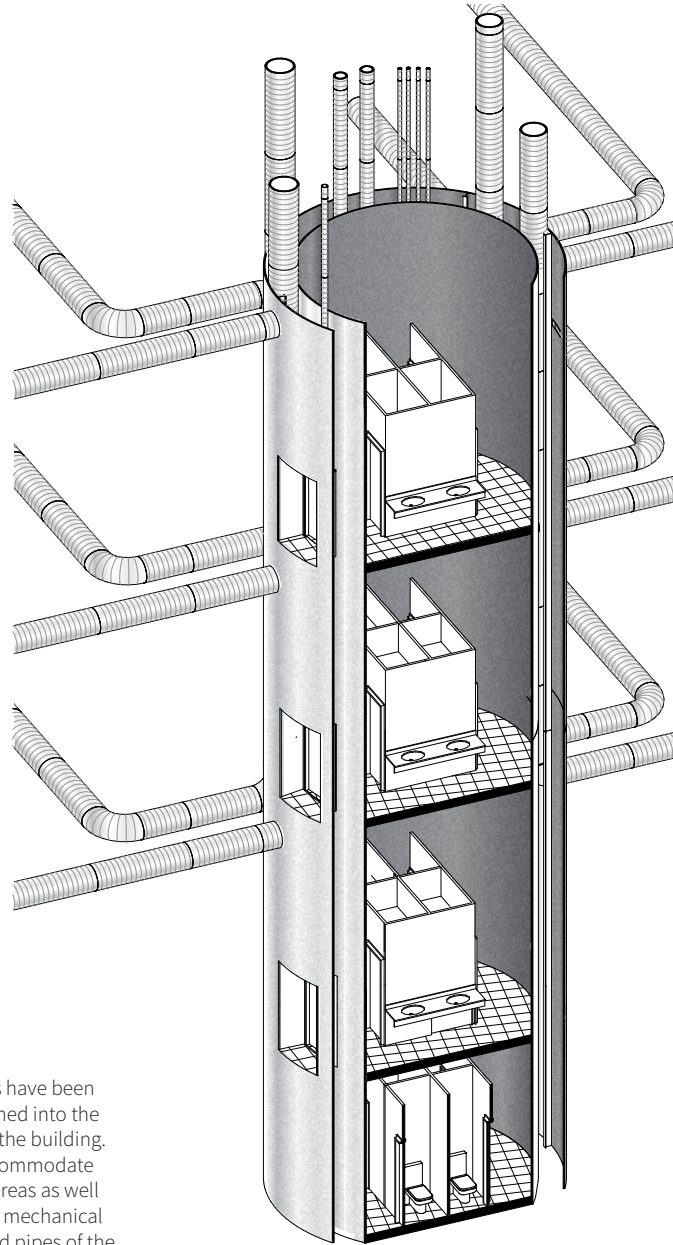

Two silos have been transformed into the shafts of the building. They accommodate the wet areas as well as all the mechanical shafts and pipes of the building.

## transformation

material library

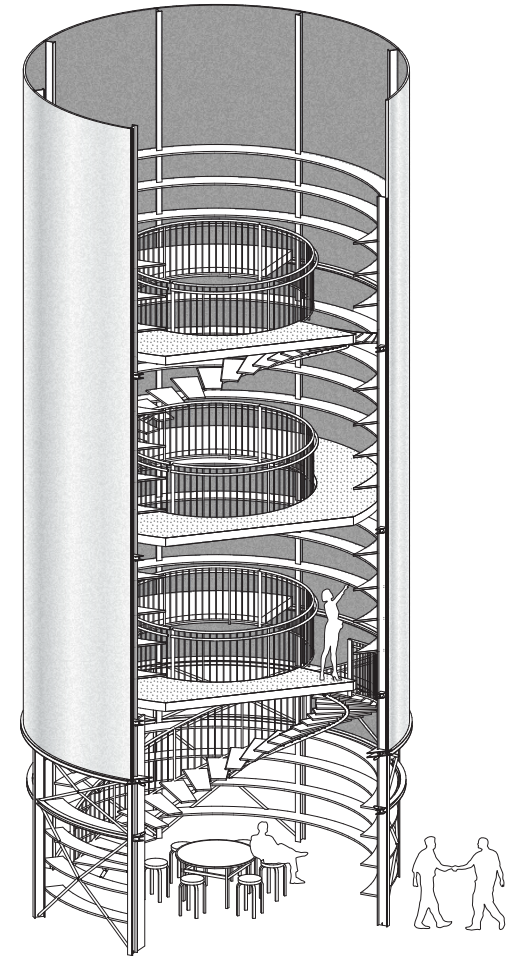

Two silos have been turned into material libraries to enable people and customers to interact with the makers and manufacturers. The silos have been raised to exhibit the interaction transparently.

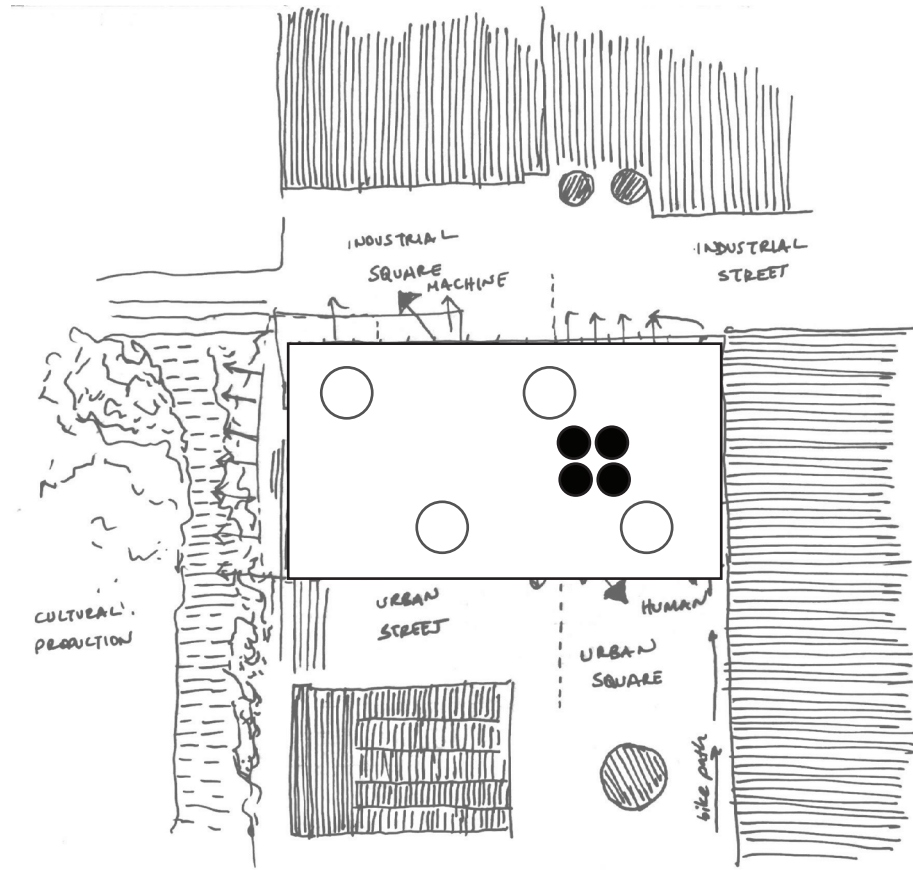

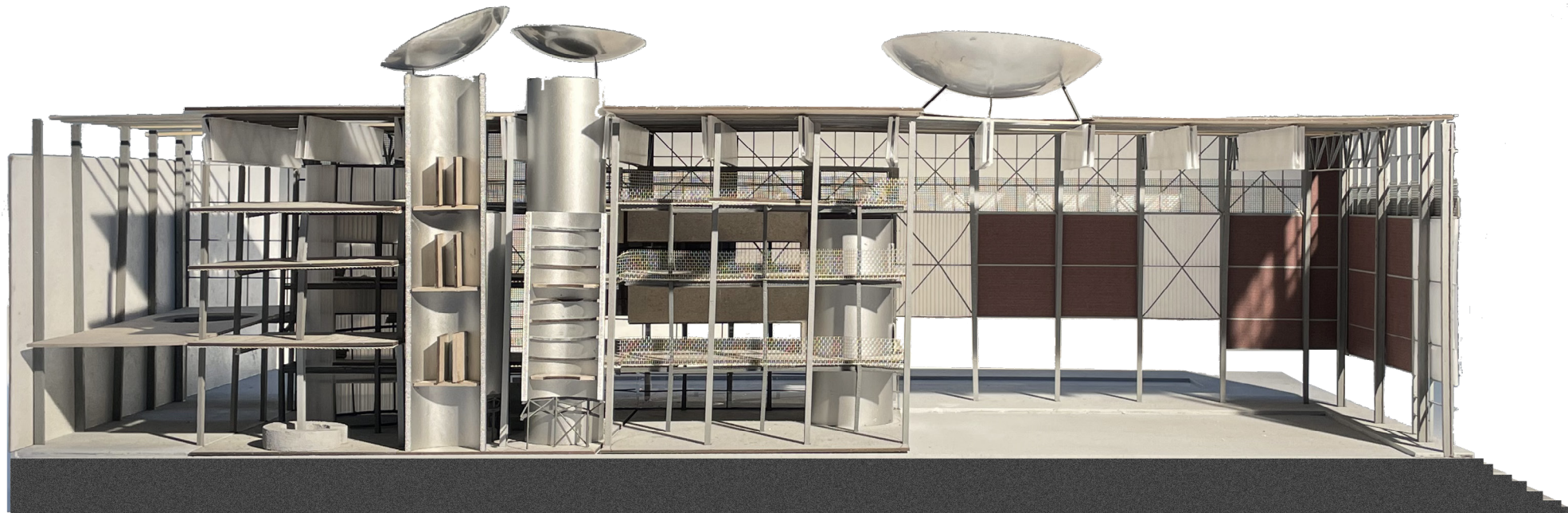

object

crane hook

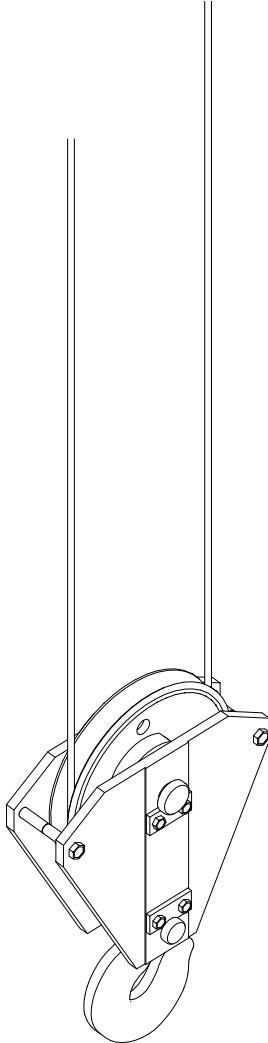

Sappi Factory, PM5

transformation

interaction storage

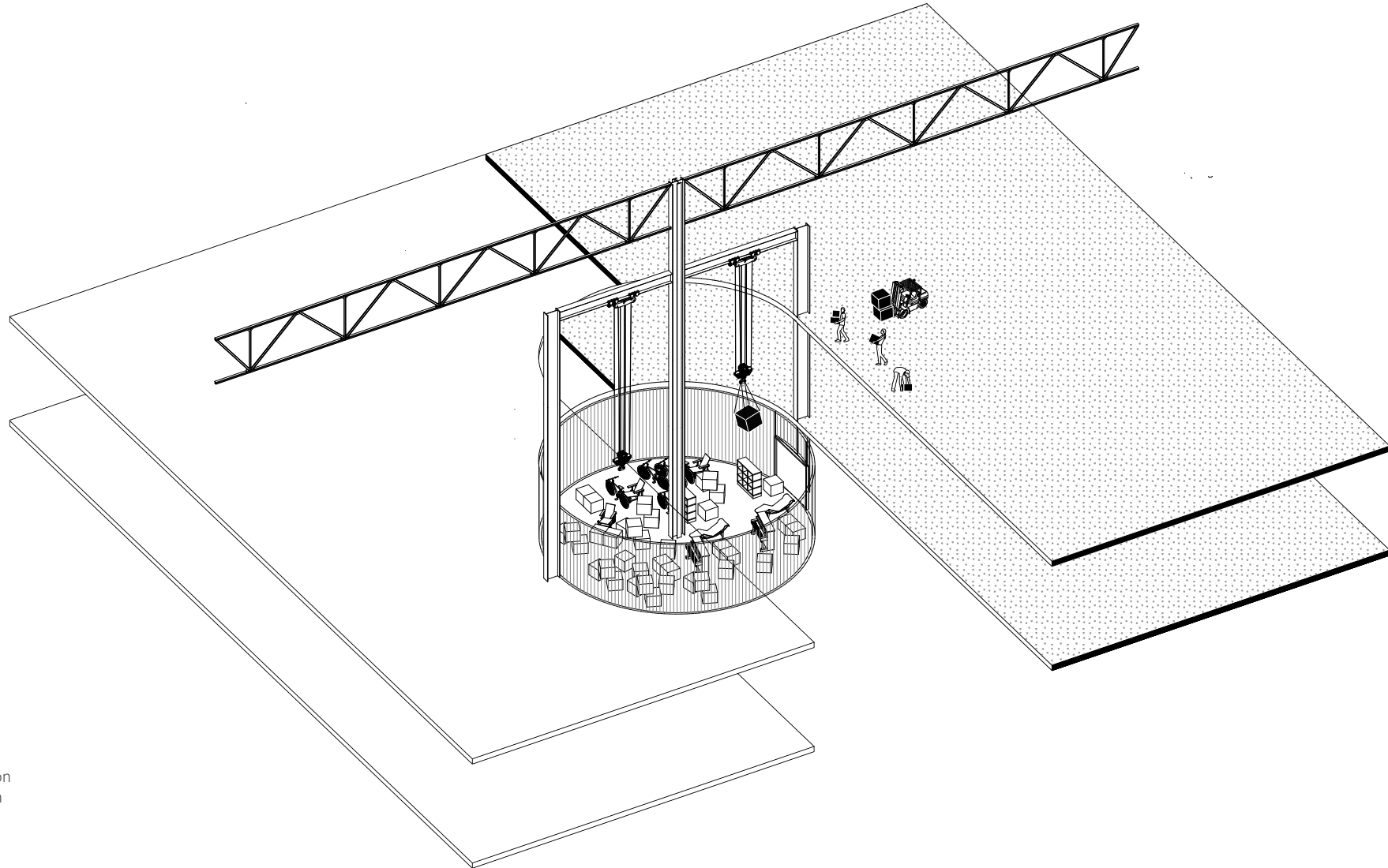

The crane hook transformation offers several interactions. It creates a physical vertical relationship between the production and public. Makers can drop their products with crane hooks into the interaction storage through which the public can observe the products.

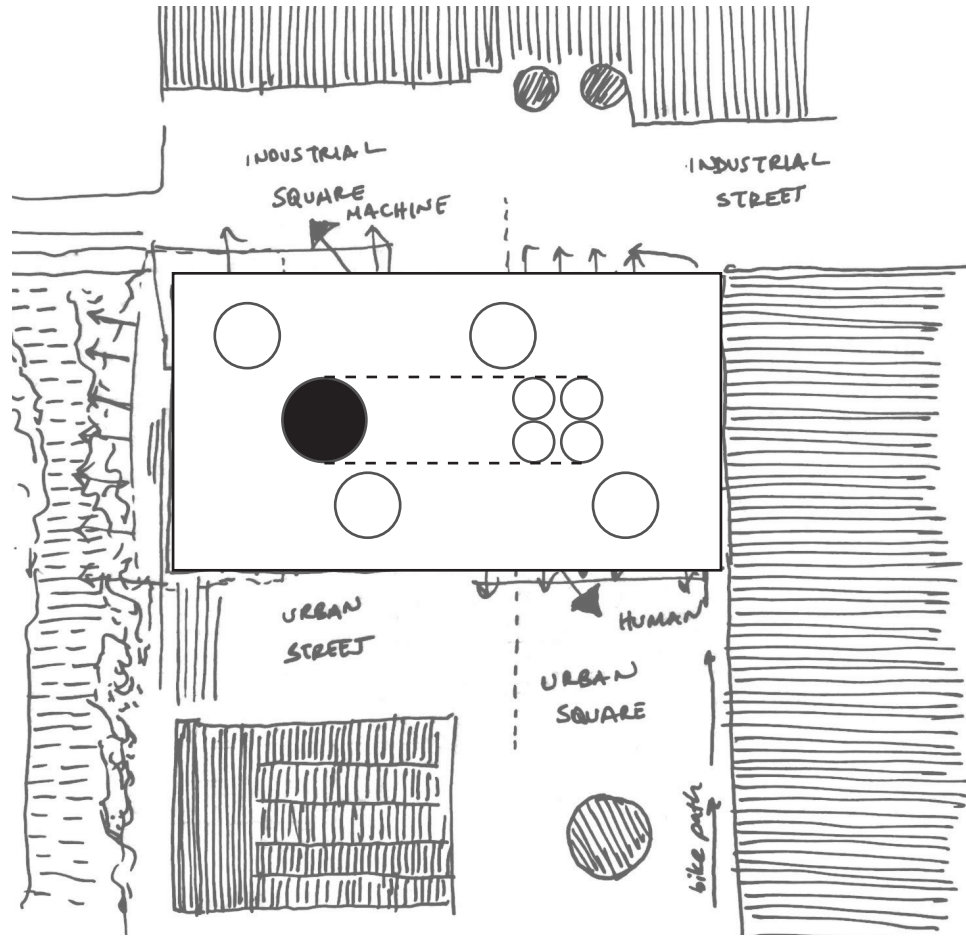

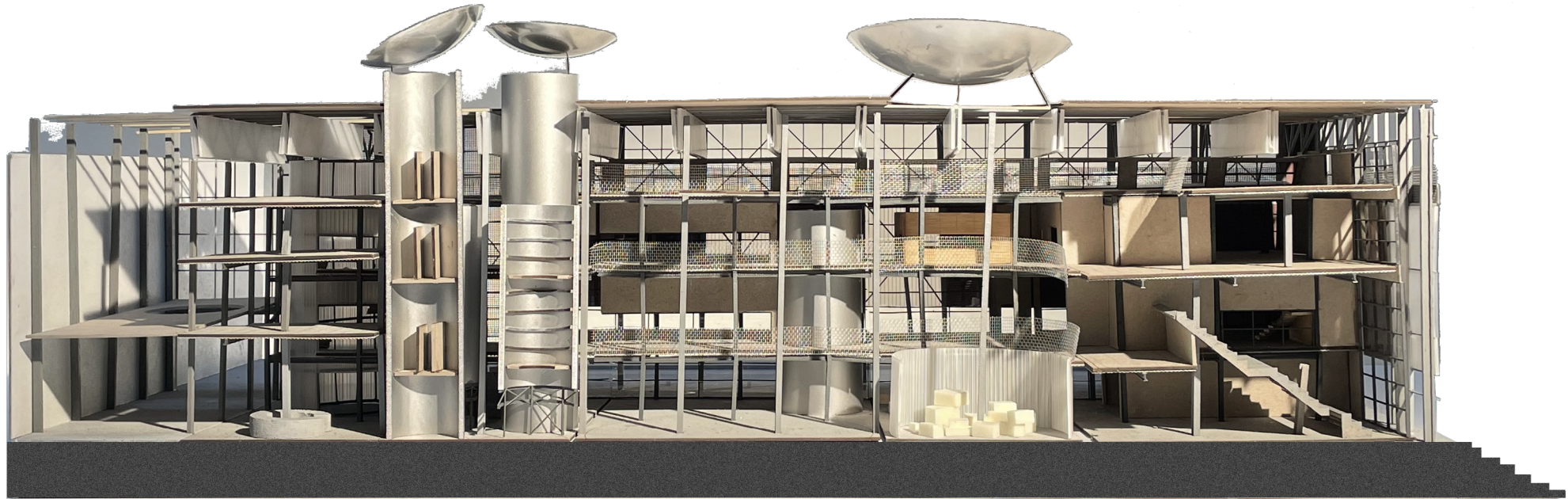

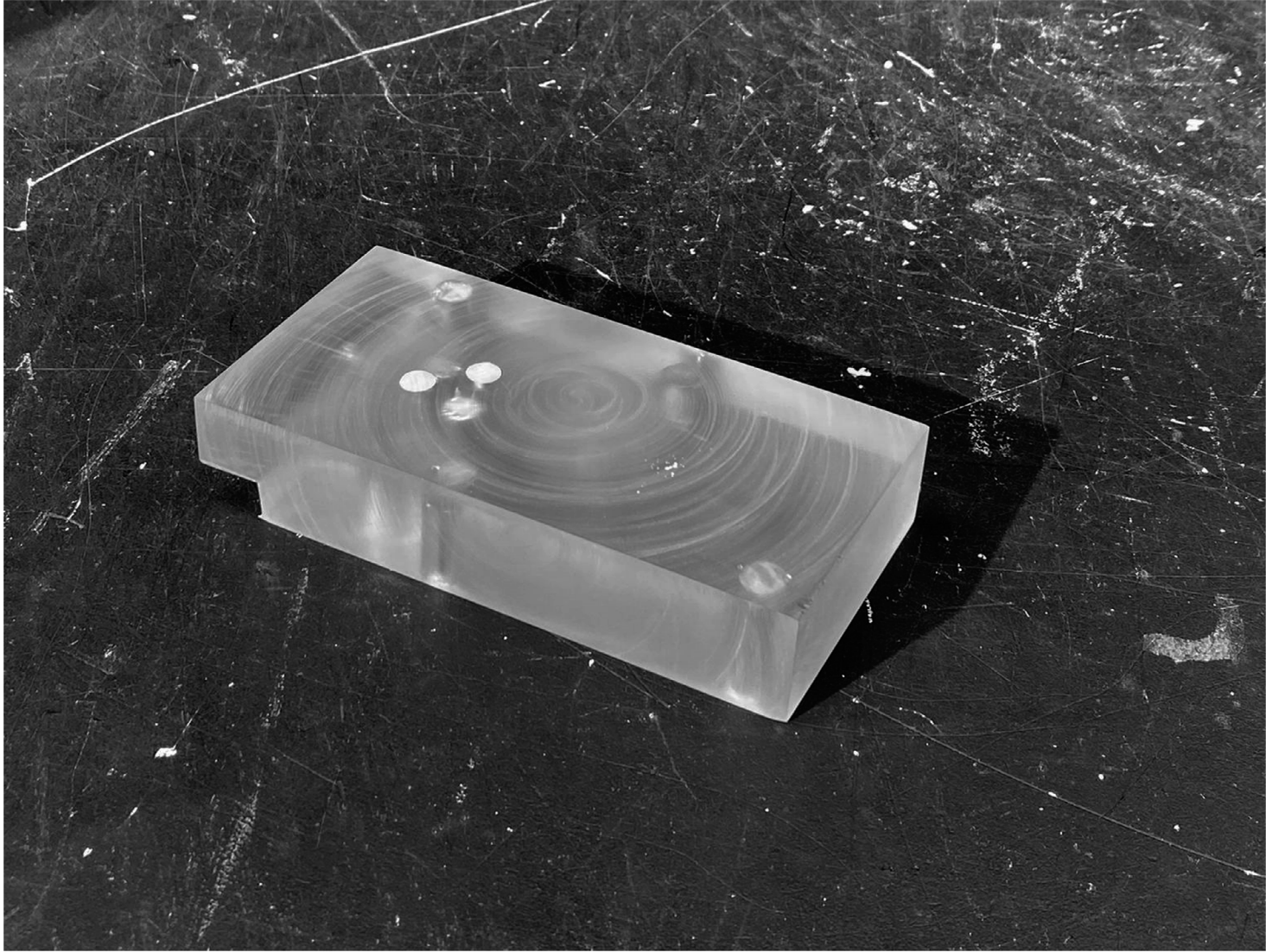

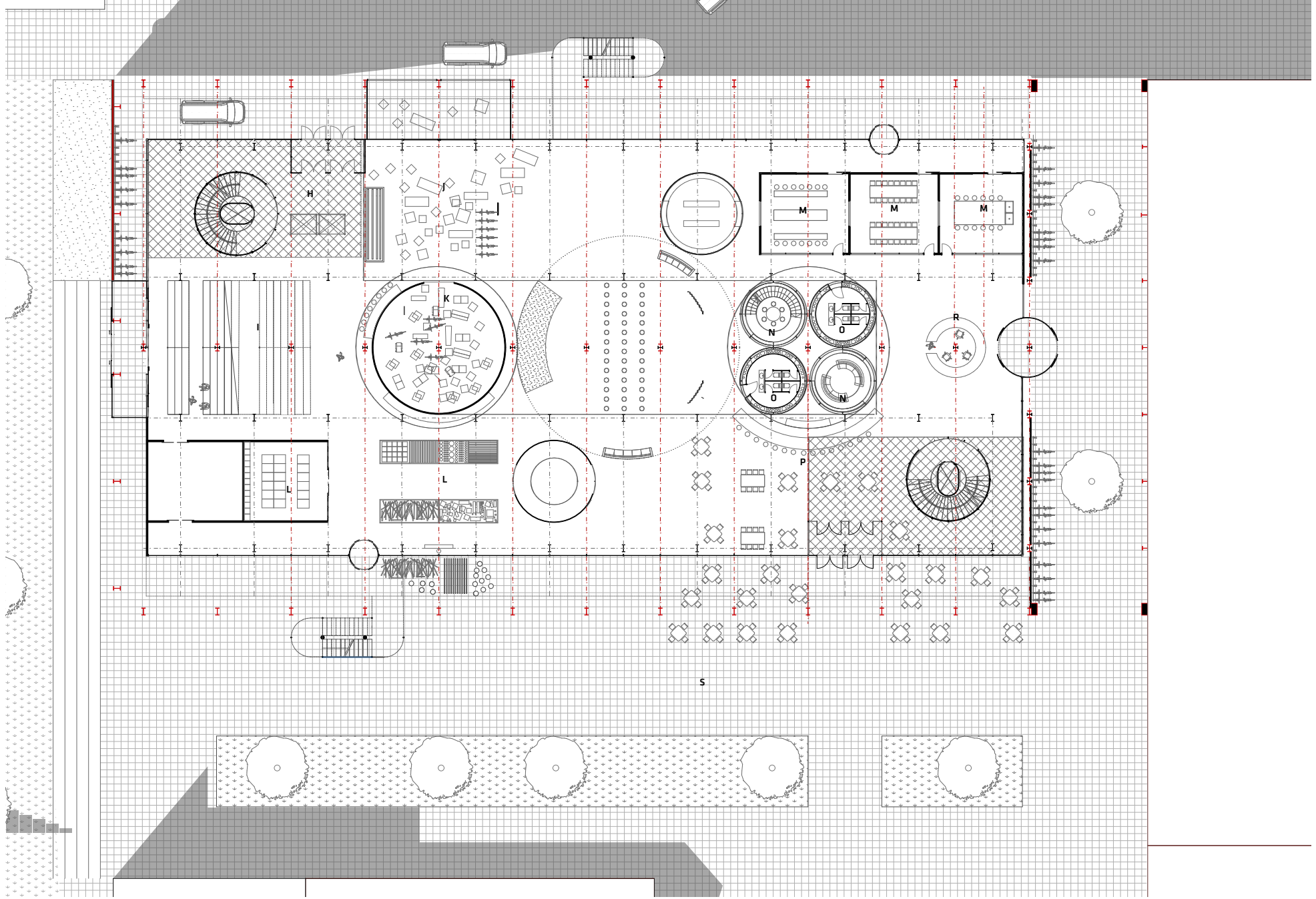

Ground Floor Plan  
1:200



A. ASSEMBLY AREA B. PRODUCTION SPACE C. MATERIAL LIBRARY D. TOILETS E. LEISURE AREA F. FLYING GARDEN

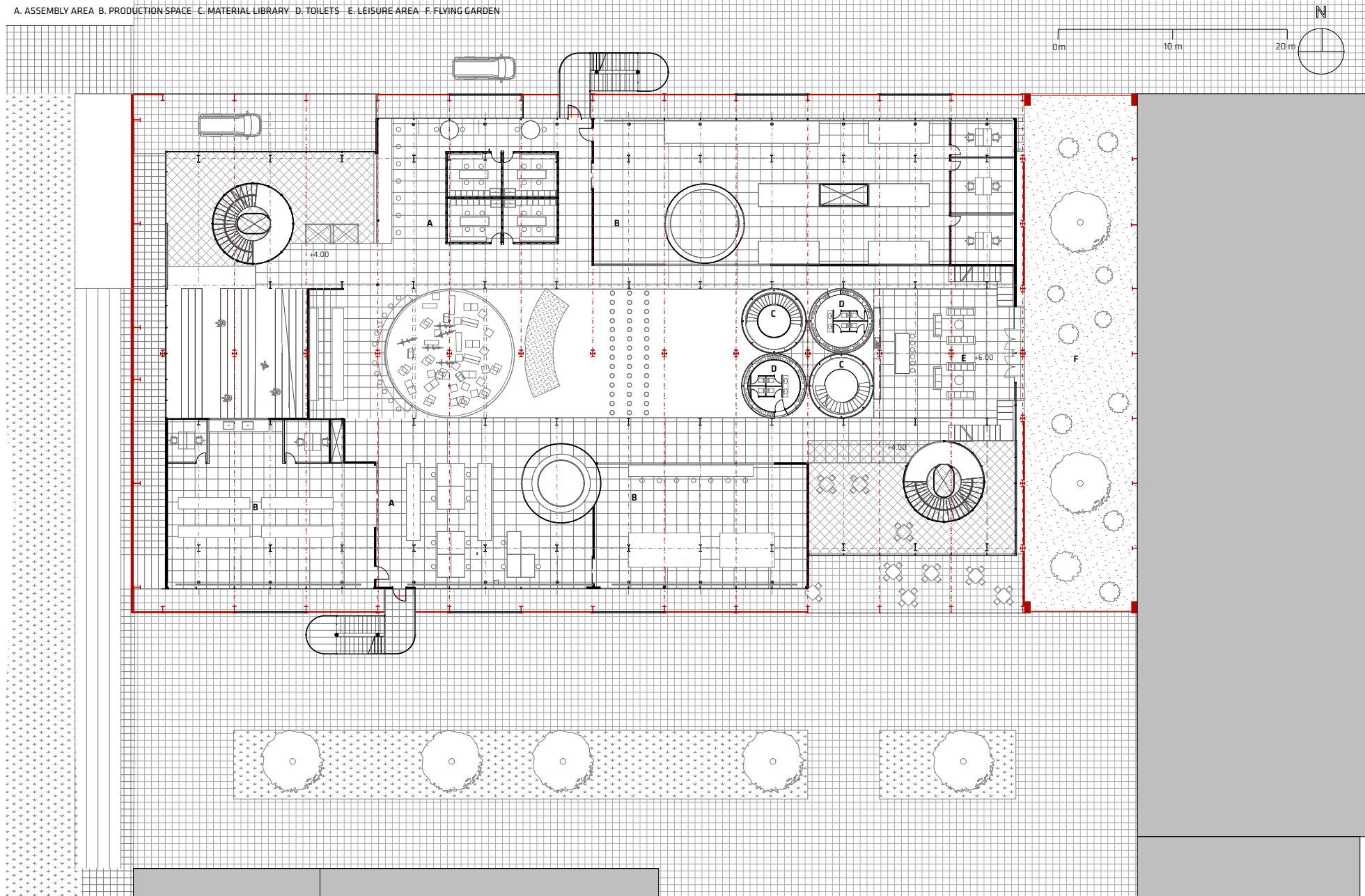



RECEPTION

A. ASSEMBLY AREA B. PRODUCTION SPACE C. FLEXIBLE MEETING SPACE D. MATERIAL LIBRARY E. TOILETS F. LEISURE AREA G. FLYING GARDEN

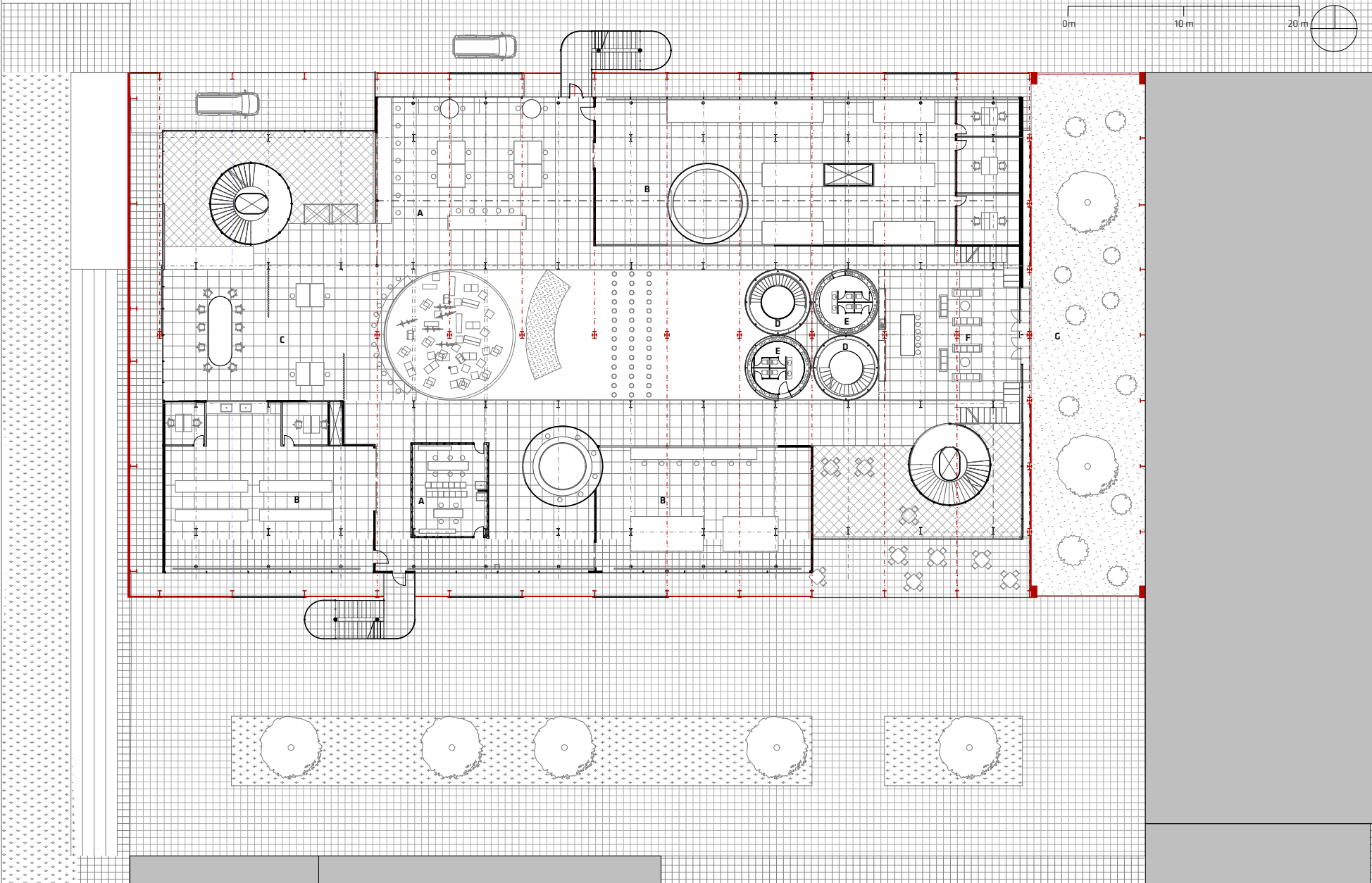
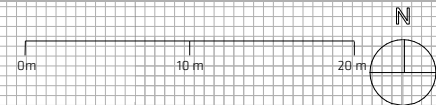

2nd Floor Plan  
1:200



A. FLEXIBLE OFFICES B. CAFE C. TOILETS D. LEISURE AREA E. RECEPTION

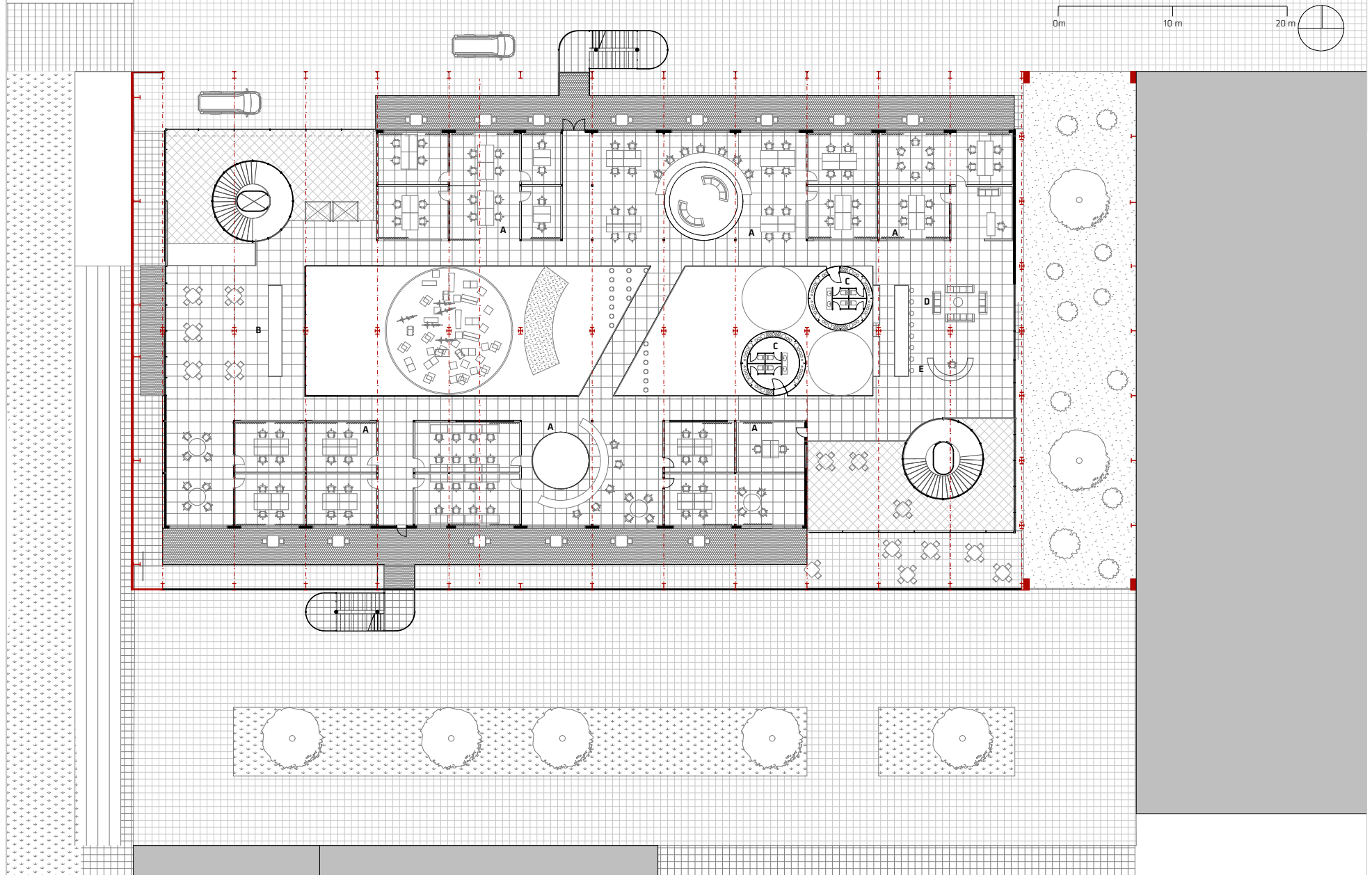
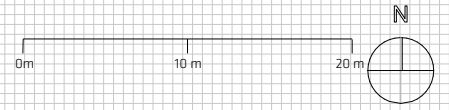

3rd Floor Plan  
1:200

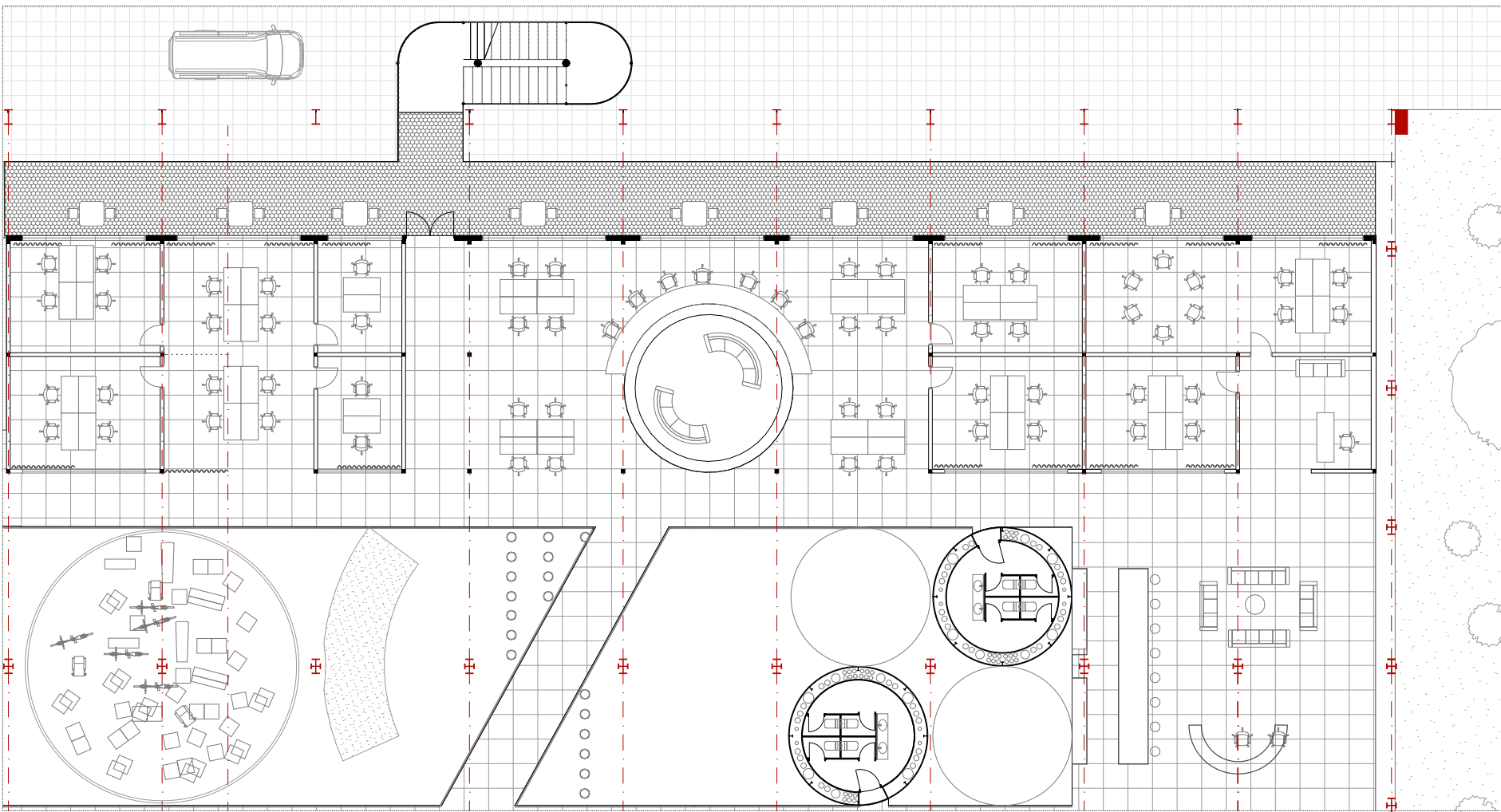



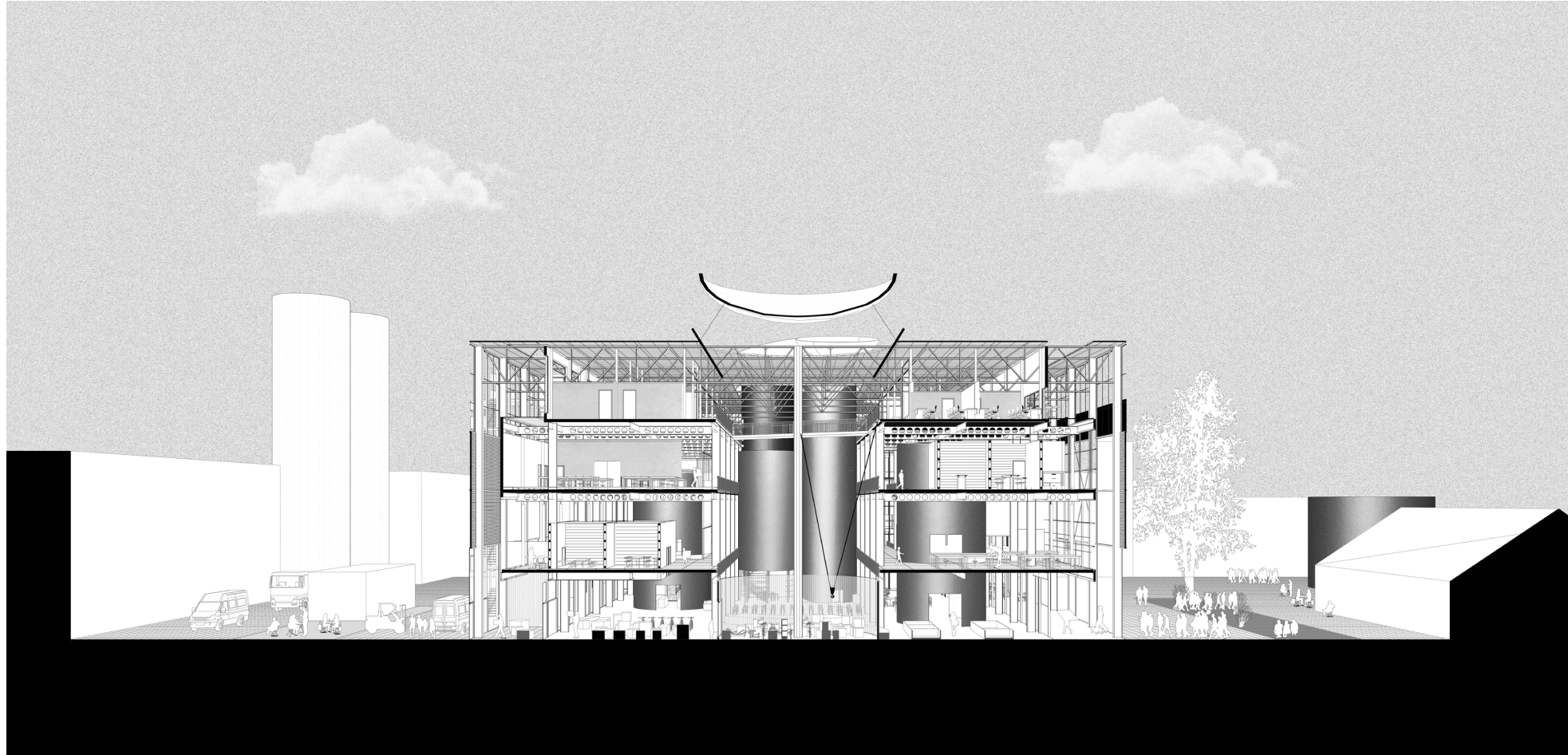

Section 1:200

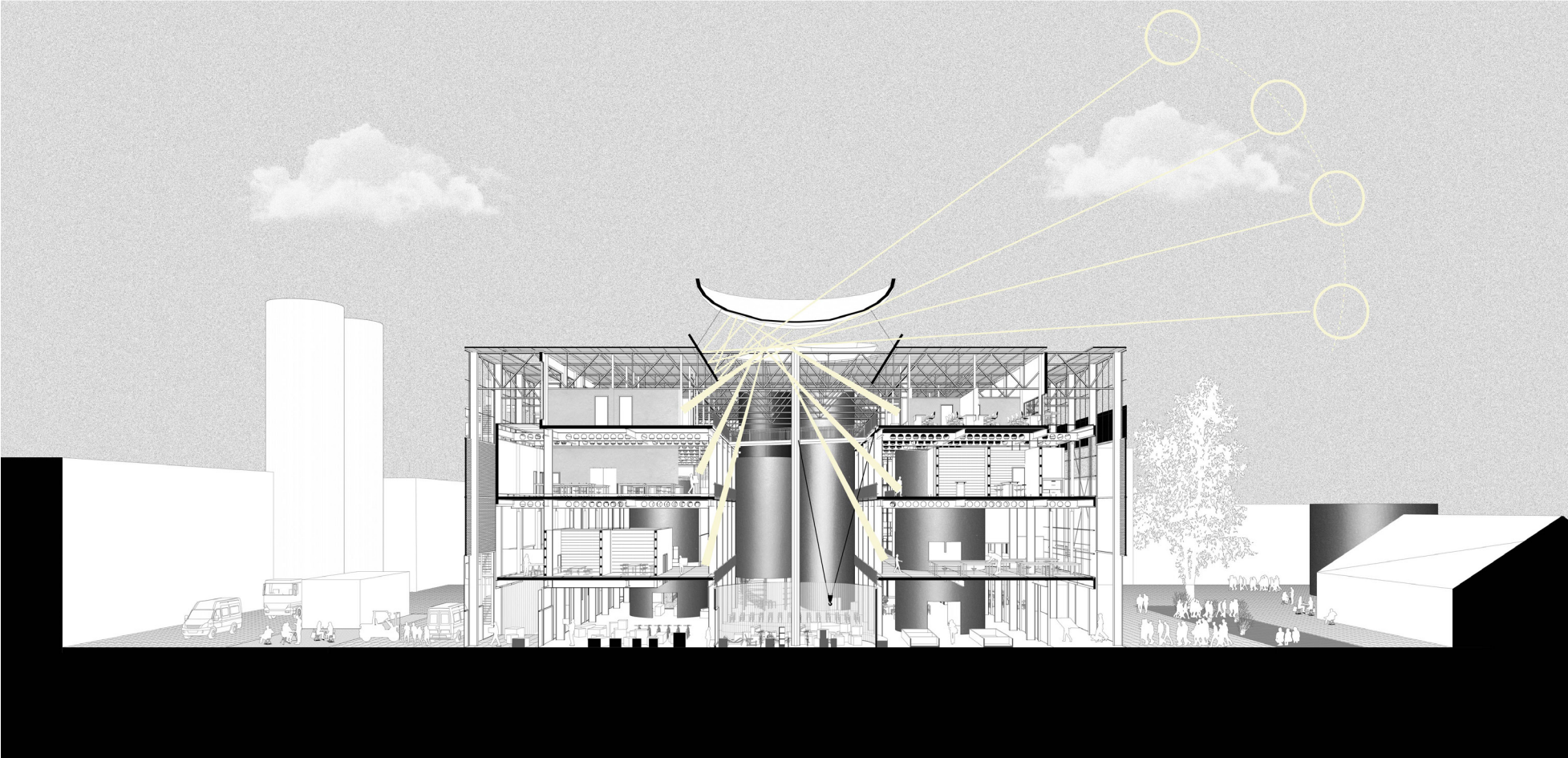

SECTION 1:200

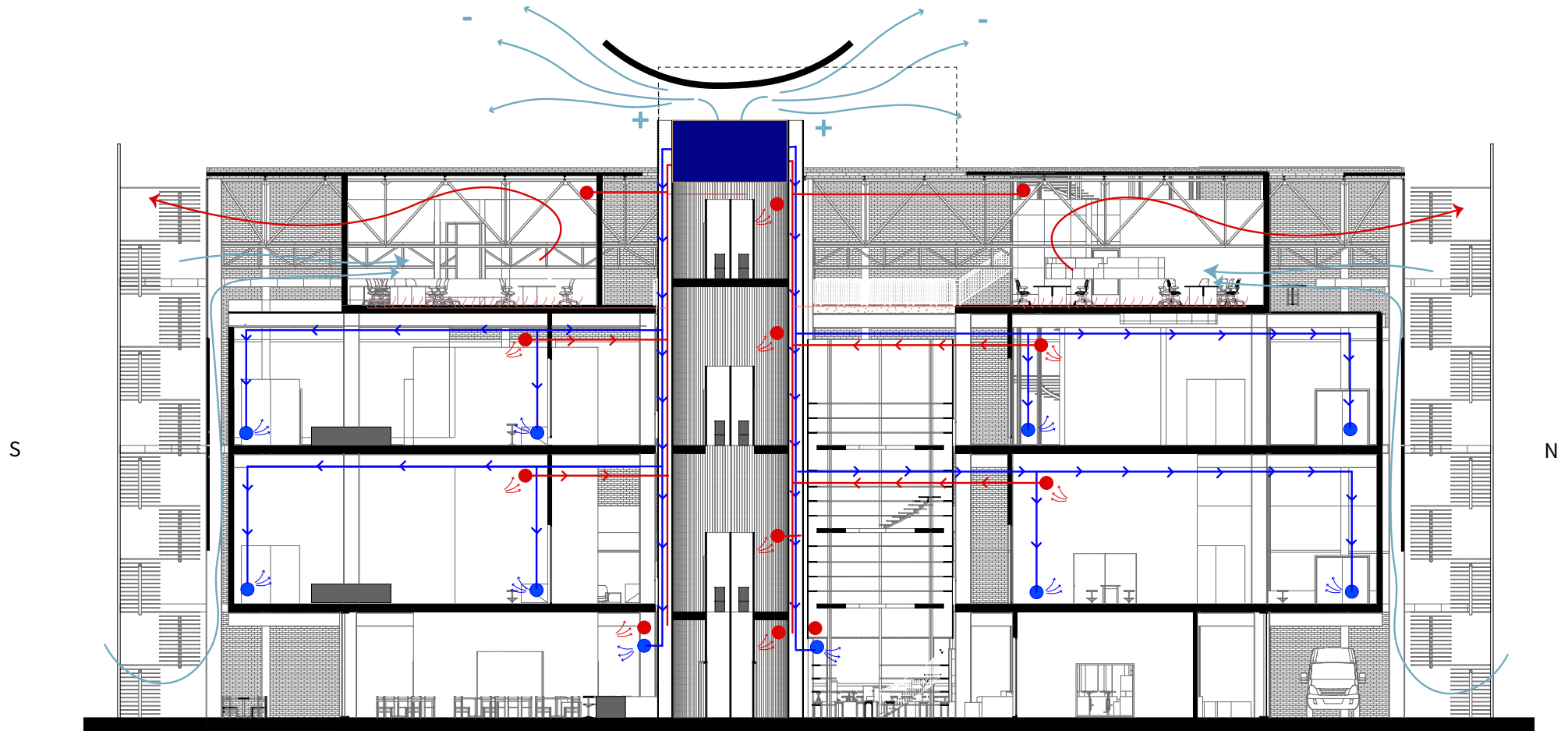

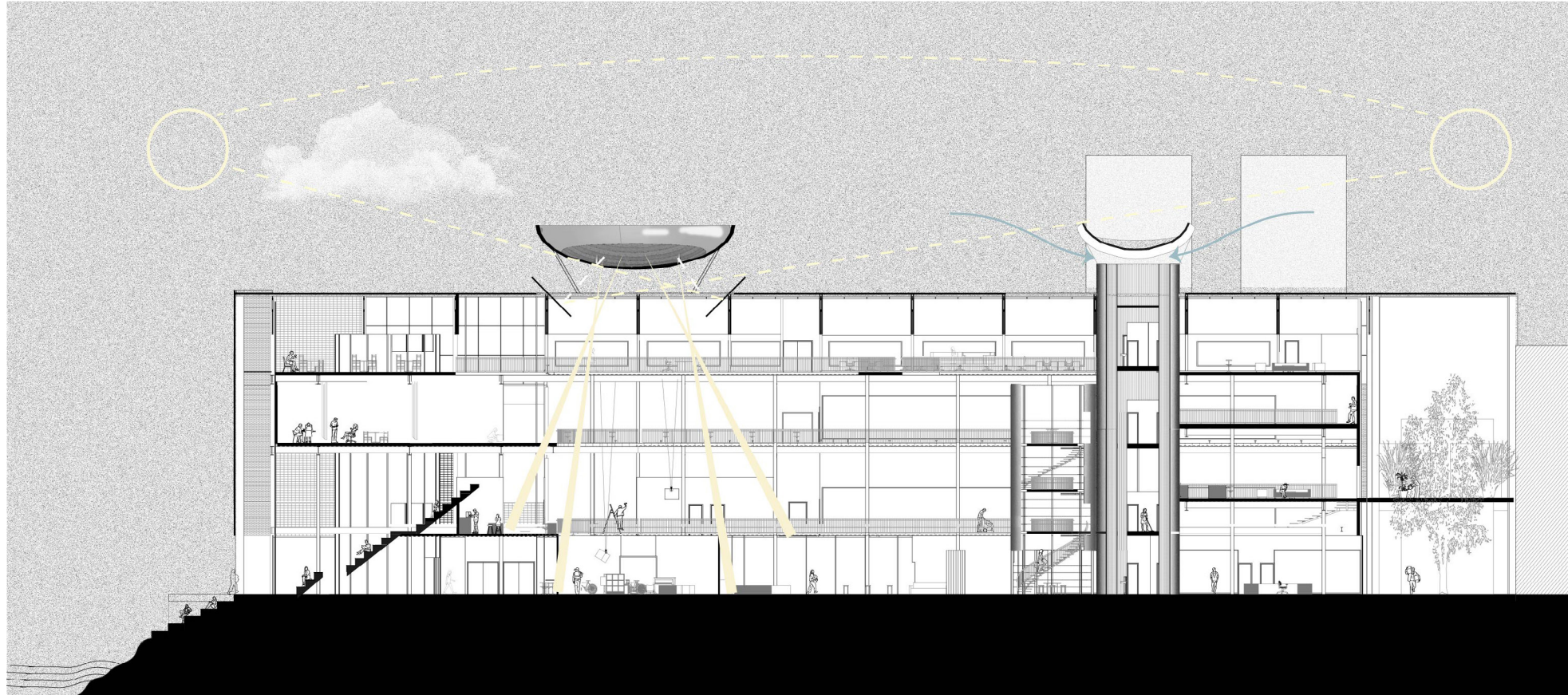

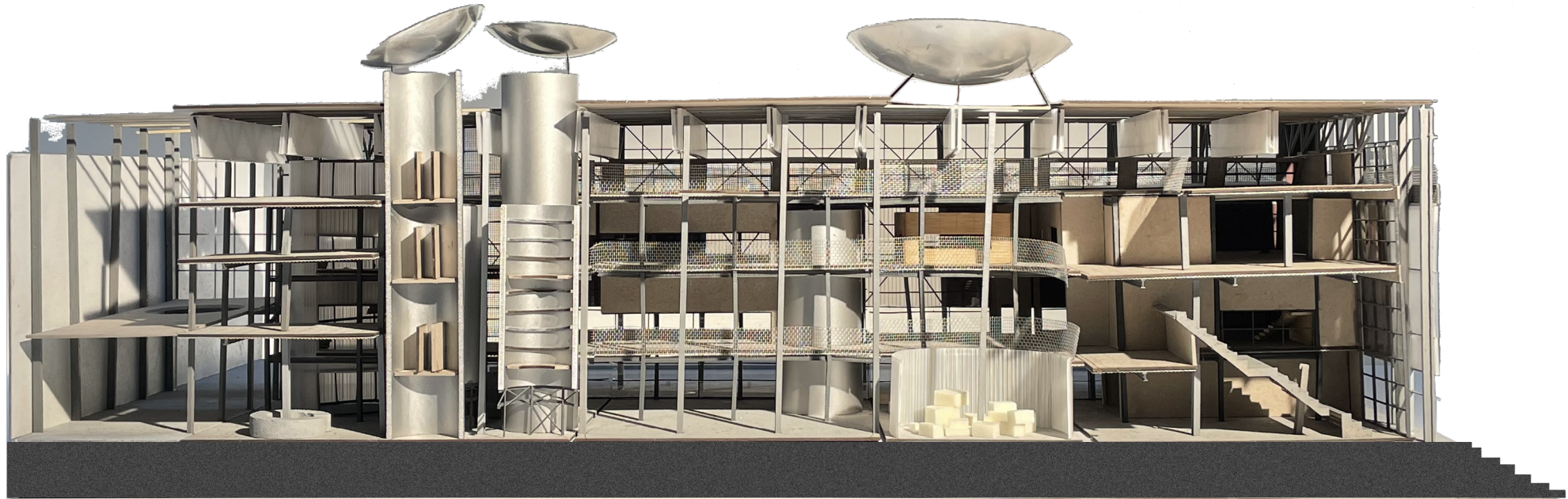

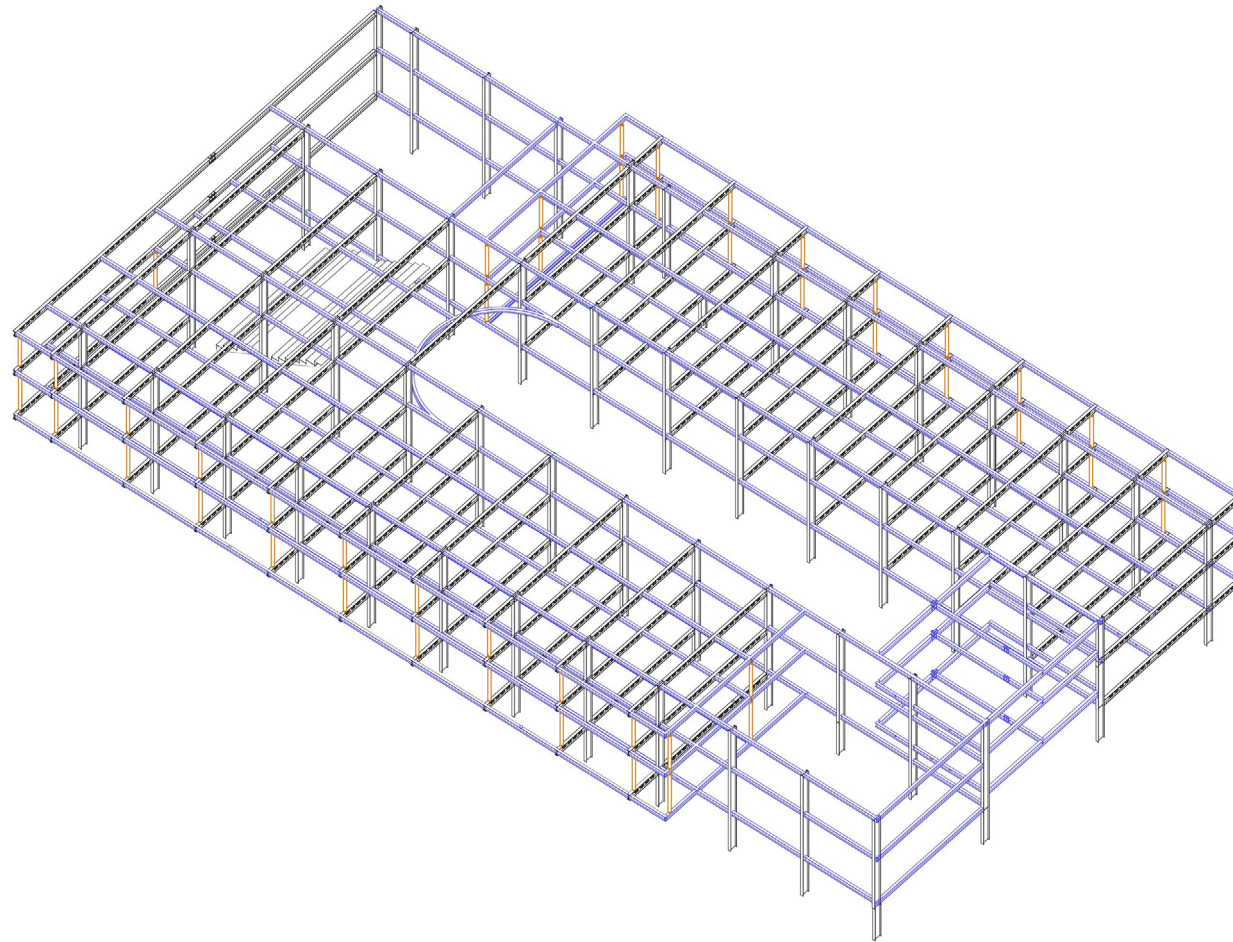

- IPE 60
- IPE 45
- circular section steel beam 220 mm

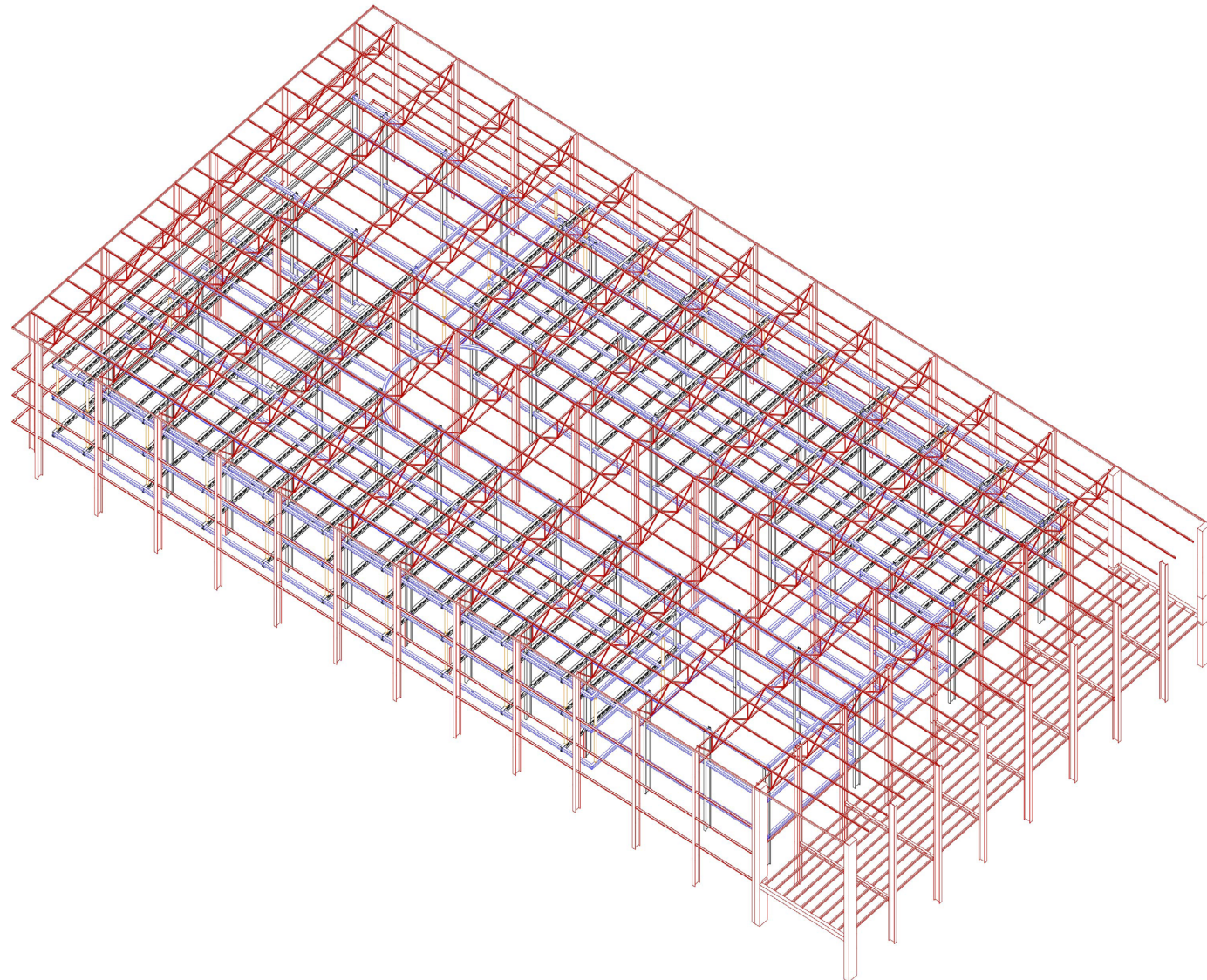

- IPE 60
- IPE 45
- circular section steel beam 220 mm
- existing structure



South (Urban ) Facade



North (Industrial) Facade



West Facade



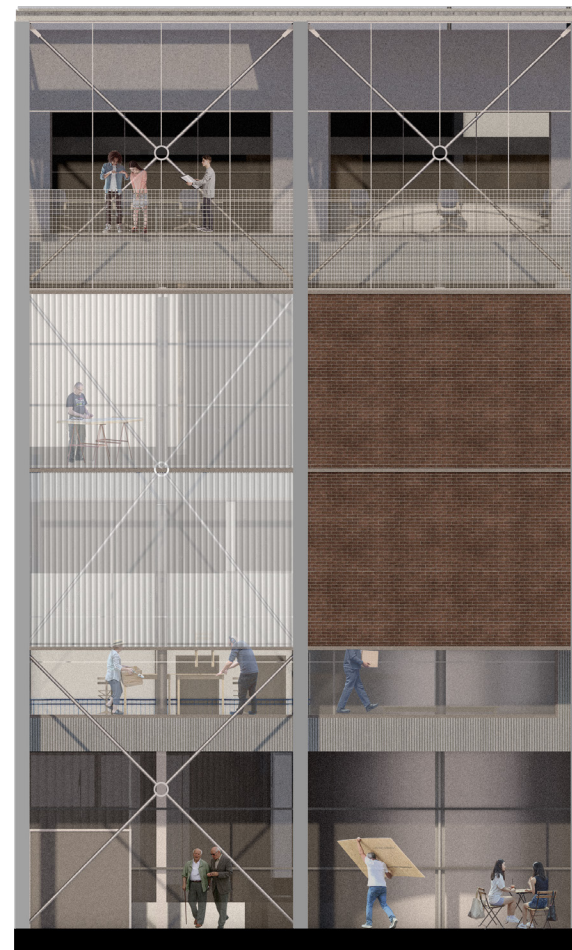
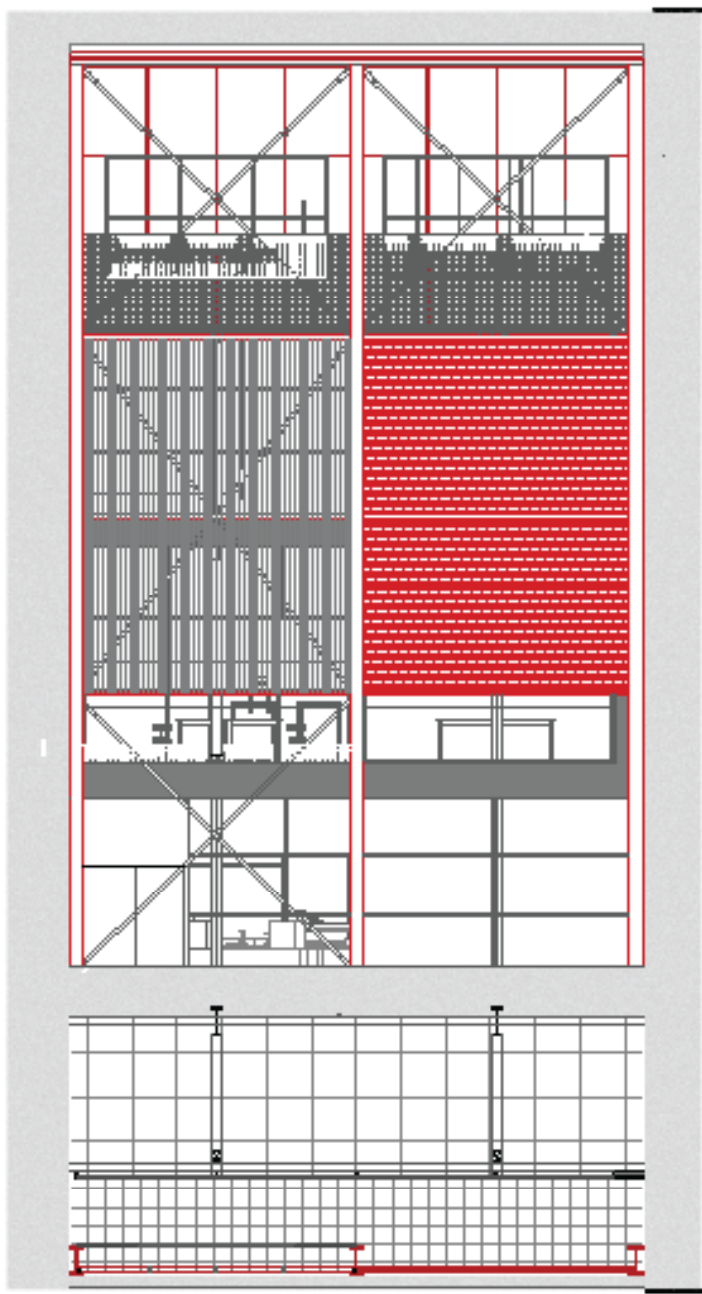
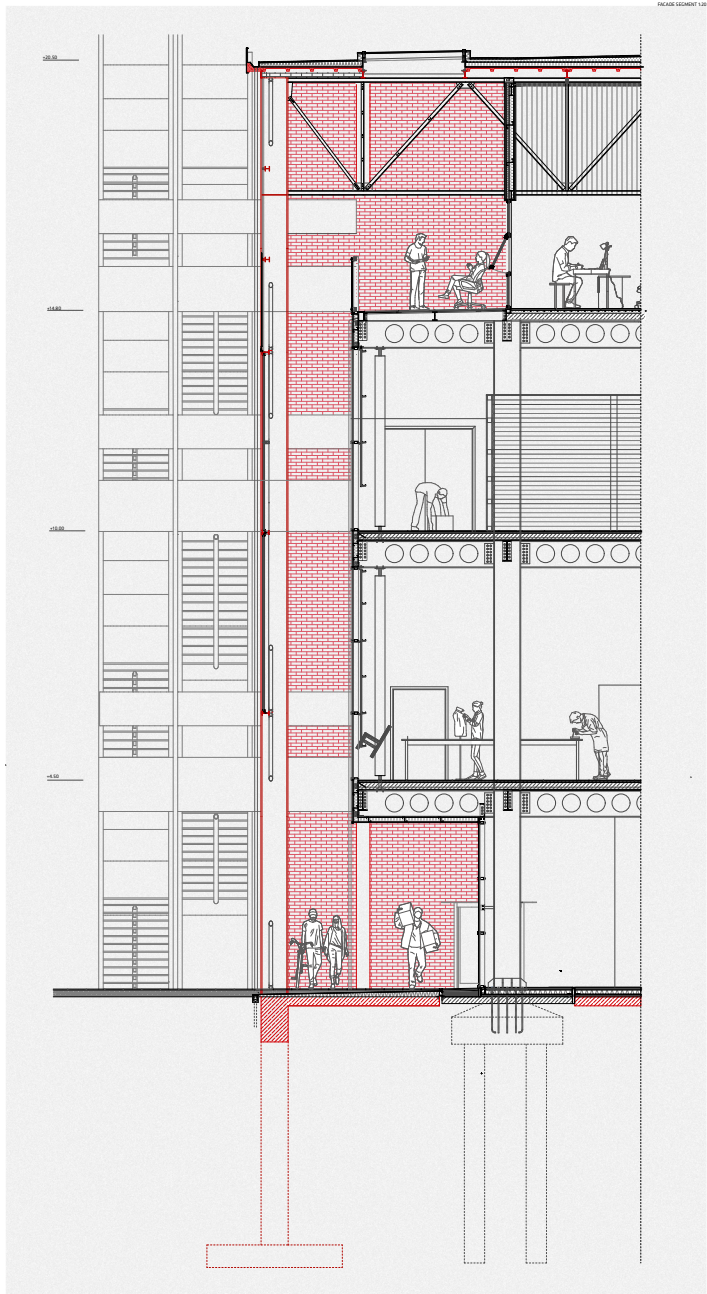

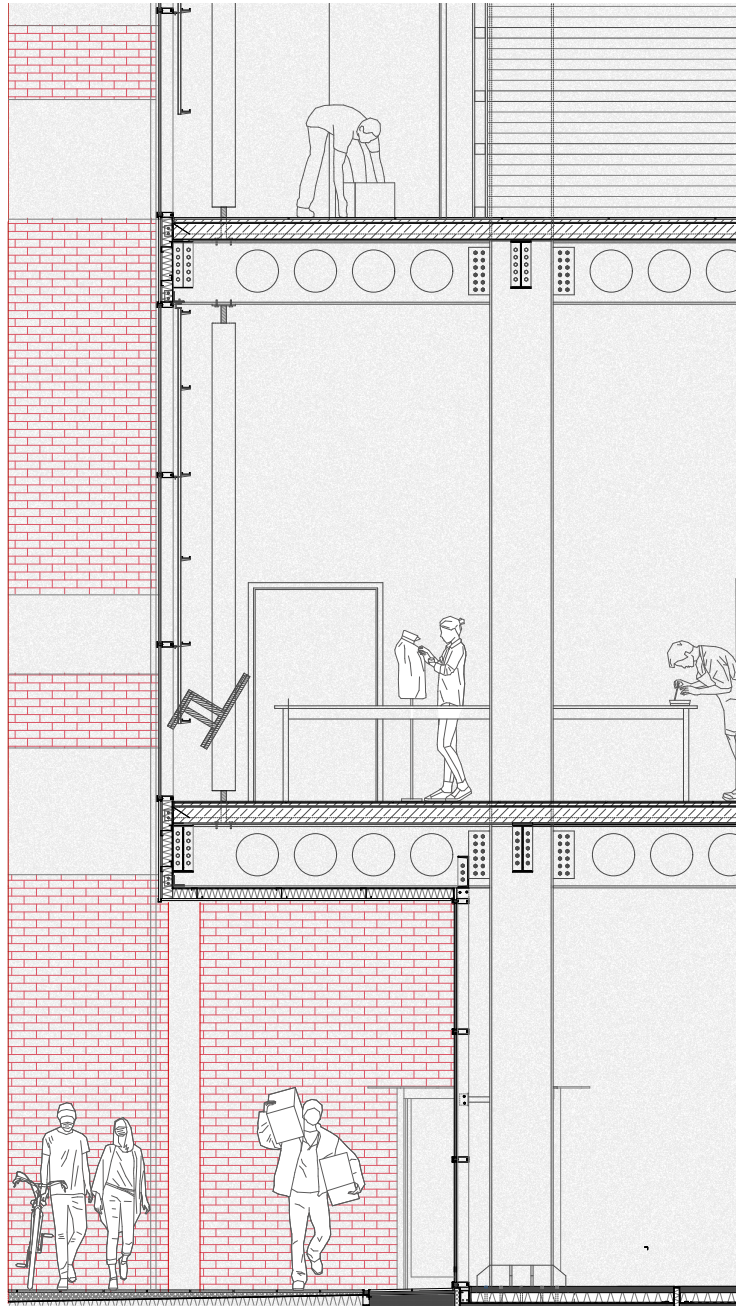

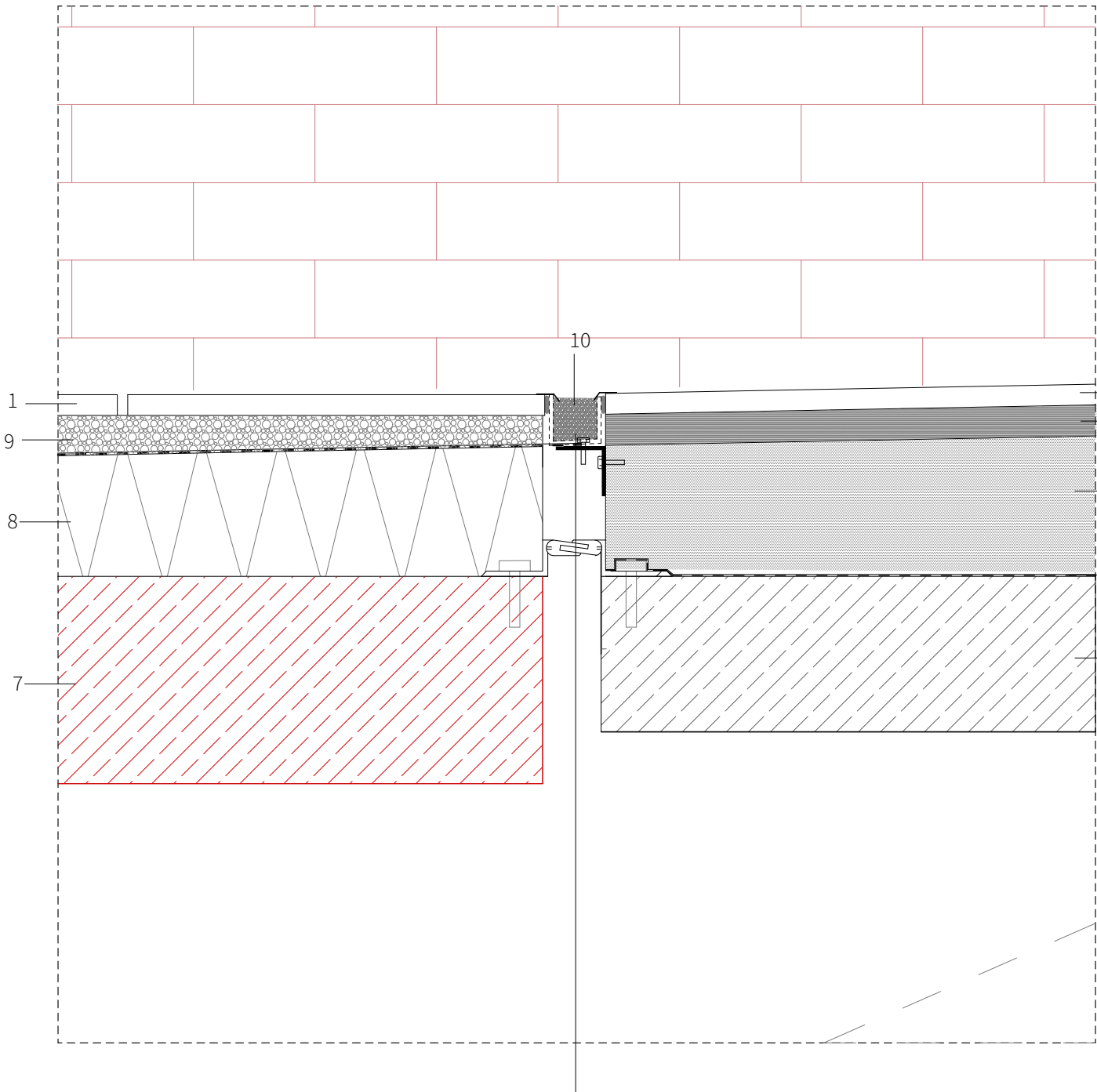

- 1. 20 mm thick outdoor tile
- 2. 30mm mortar
- 3. 150 mm inclined screed
- 4. Vapour barrier
- 5. 150mm new concrete slab
- 6. Expansion joint
- 7. Existing concrete slab
- 8. Inclined insulation
- 9. Gravels
- 10. Perforated metal profile

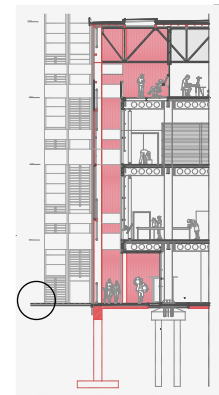

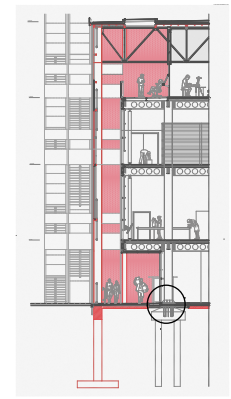
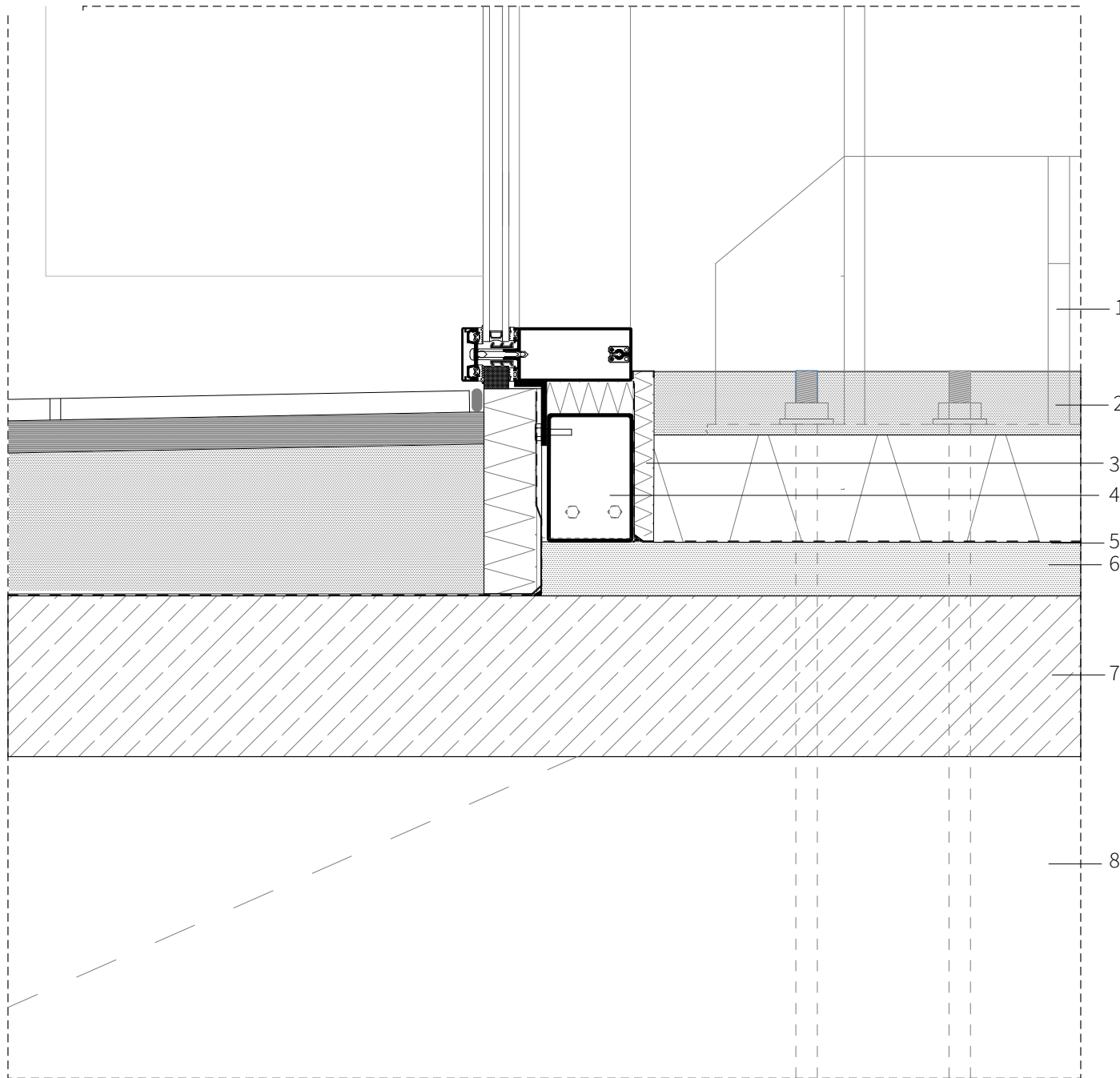

- 1. IPE 600 columns
- 2. 600mm screed
- 3. 20 mm rigid insulation
- 4. 80x120 steel box profile
- 5. Vapour barrier
- 6. 50mm screed
- 7. 150 mm newconcrete slab

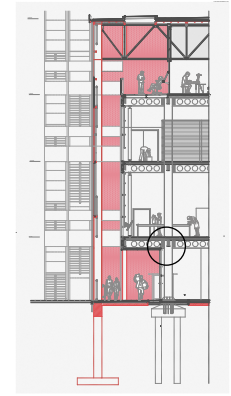
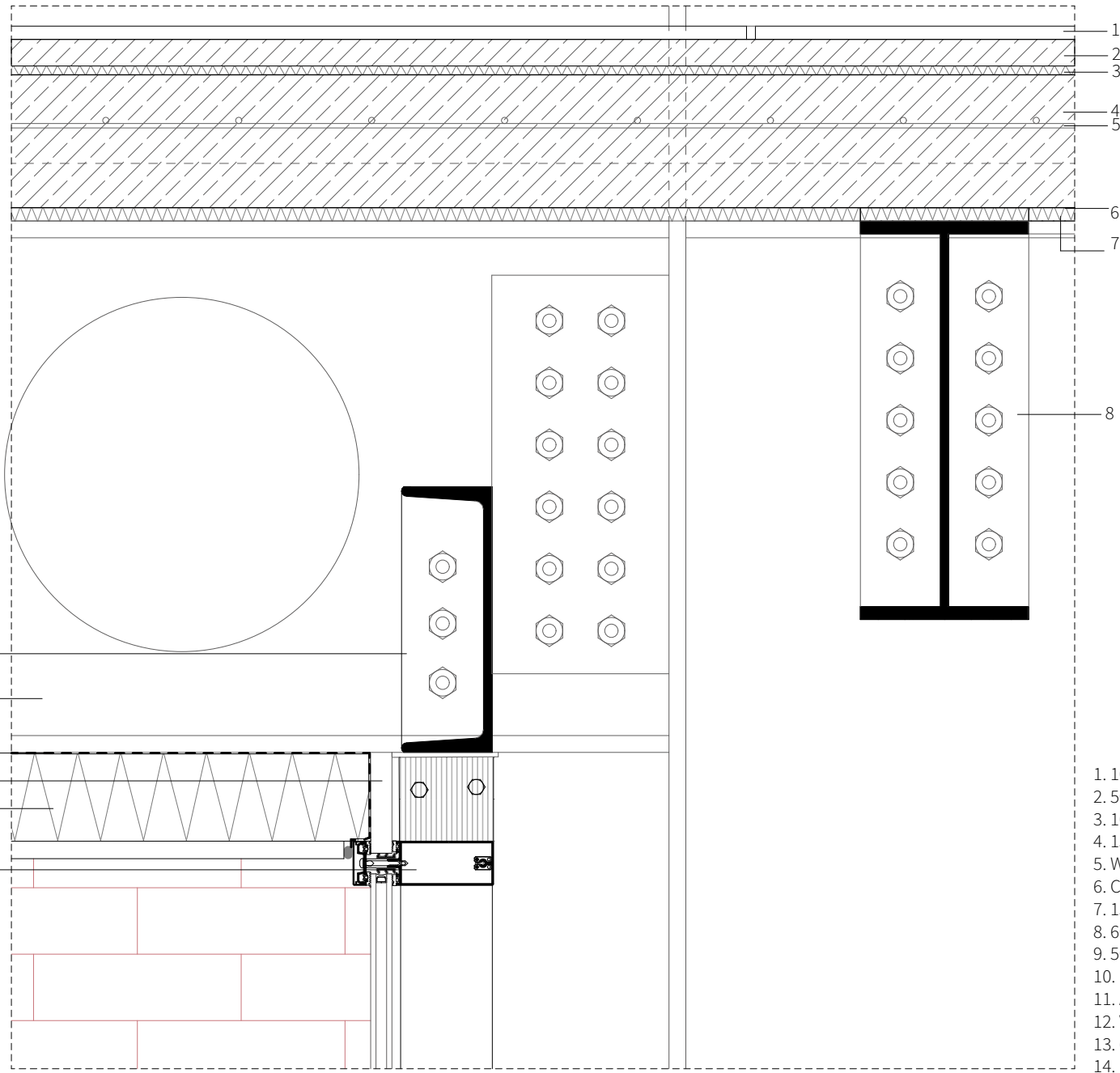

- 1. 1000mmx1000mmx15mm concrete look porcelain tiles
- 2. 50mm mortar
- 3. 10 mm acoustic mat
- 4. 150mm composite floor slab
- 5. Welding wire reinforcing mesh
- 6. Corrugated steel deck
- 7. 15 mm rubber mat
- 8. 600 mm deep cellular beam
- 9. 50mmx100mm curtain wall
- 10. 100mm rigid insulation
- 11. Aluminium sheet cladding pressed into curtain wall
- 12. Vapour barrier
- 13. 600 mm deep cellular beam
- 14. UPN300

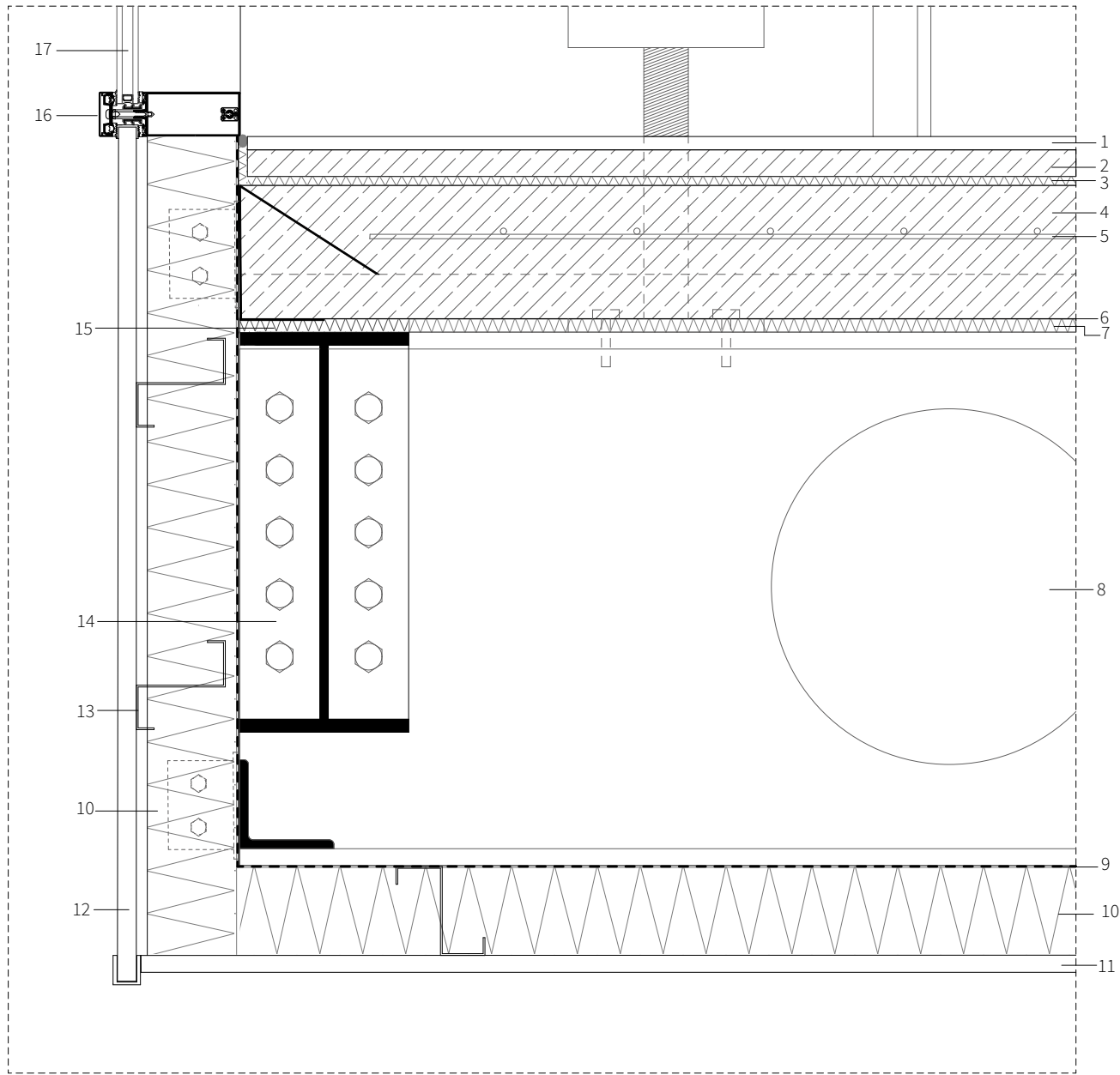

1. 1000mmx1000mmx15mm concrete look porcelain tiles
2. 50mm mortar
3. 10 mm acoustic mat
4. 150mm composite floor slab
5. Welding wire reinforcing mesh
6. Corrugated steel deck
7. 15 mm rubber mat
8. 600 mm deep cellular beam
9. Vapour barrier
10. 100mm rigid insulation
11. Aluminium sheet cladding
12. Corrugated metal Cladding
13. Z profile 100mmx50mmx2,5mm
14. IPE450
15. 15mm rubber mat
16. 50mmx 100mm curtain wall
17. Insulated double glass (6mm-12mm-18mm)

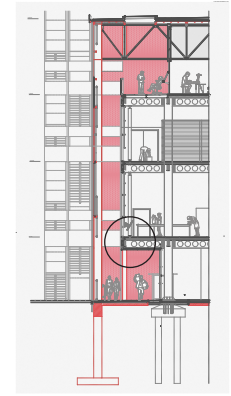

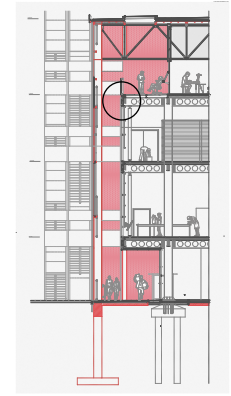
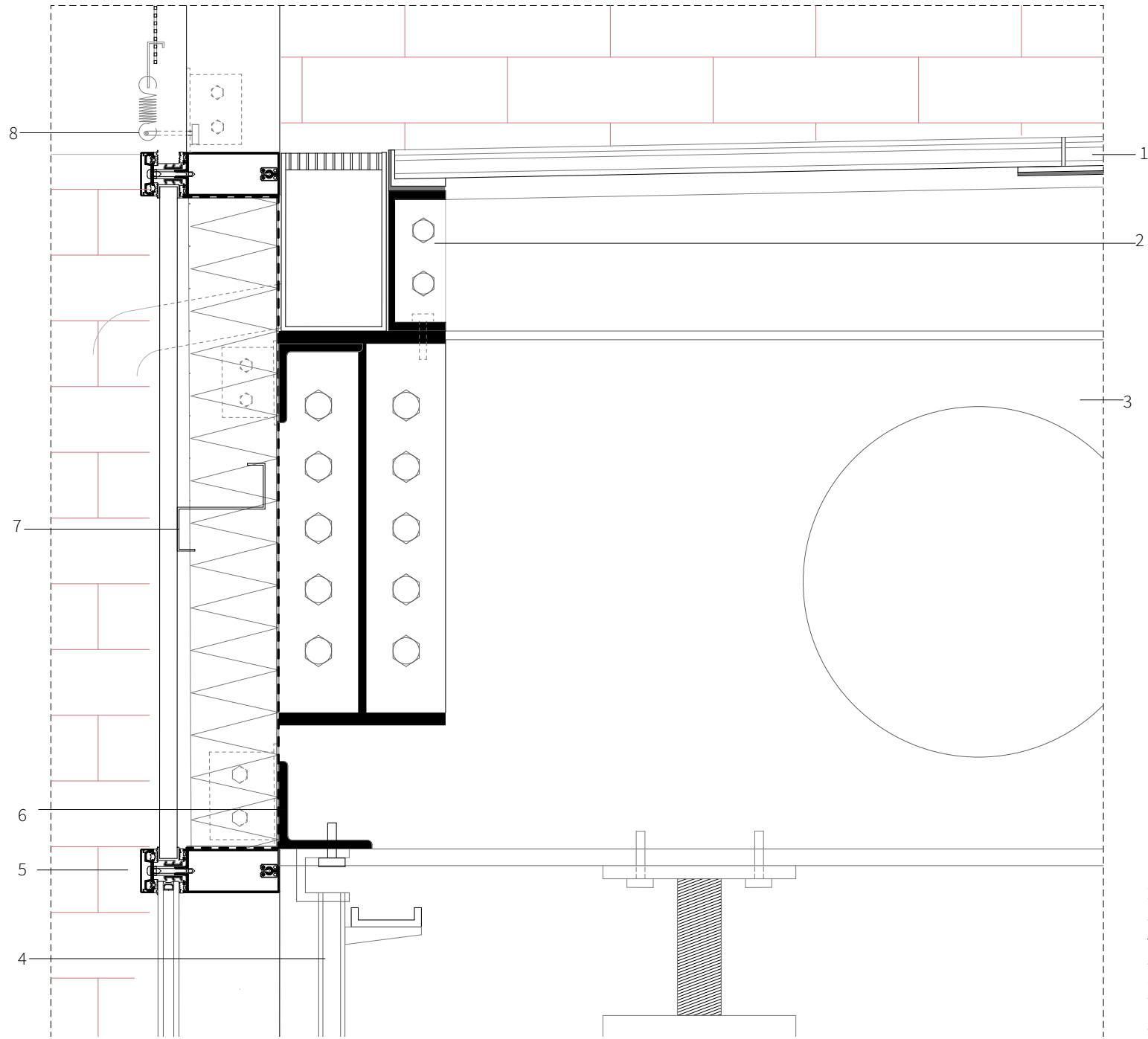

- 1. Insulated laminated frosted glass
- 2. UPN 160
- 3. 600 mm deep cellular beam
- 4. Cable tray
- 5. 50mmx100mm curtain wall
- 6. 100mmx100mm L profile
- 7. Z profile 100mmx50mmx2,5mm
- 8. IPE450

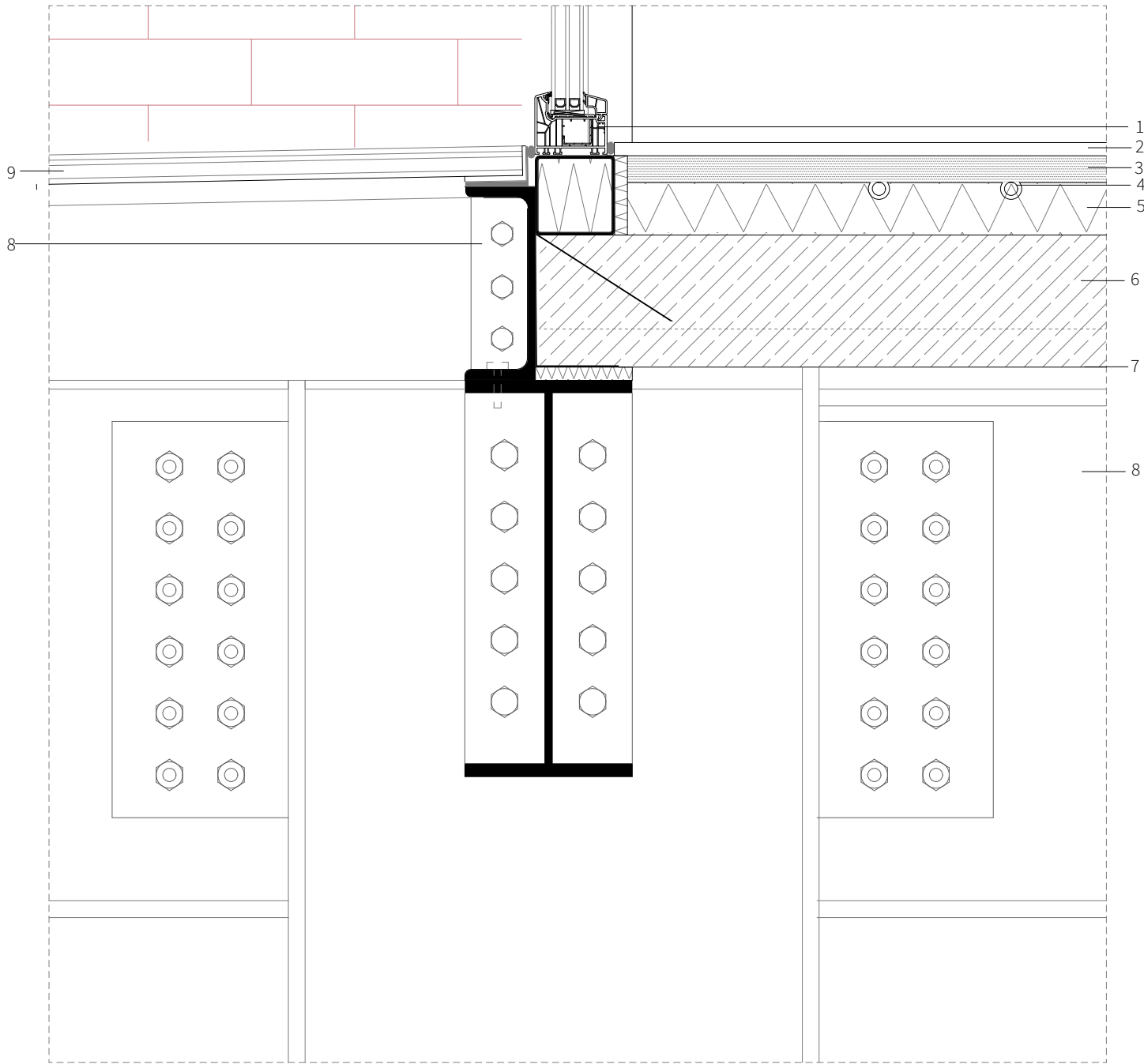

1. Fixed aluminium frame
2. 1000mmx1000m percelain tiles with concrete look
3. 30 mm mortat
4. Underfloor heating pipes
- 5, 50mm rigid insulation
6. 150 mm composite slab
7. Corrugated steel deck
8. IPE450
8. UPN200
9. Insulated laminated glass floor

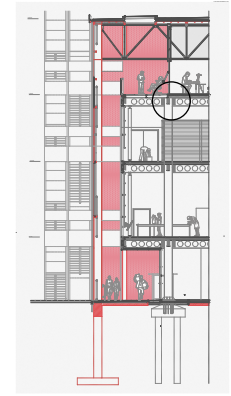

transformations

1:50

**APPROPIATION**

transformations

1:50

**PRODUCTS**



Het Werkgebouw



Het Werkgebouw



Het Werkgebouw



Het Werkgebouw



Het Werkgebouw



Het Werkgebouw

object

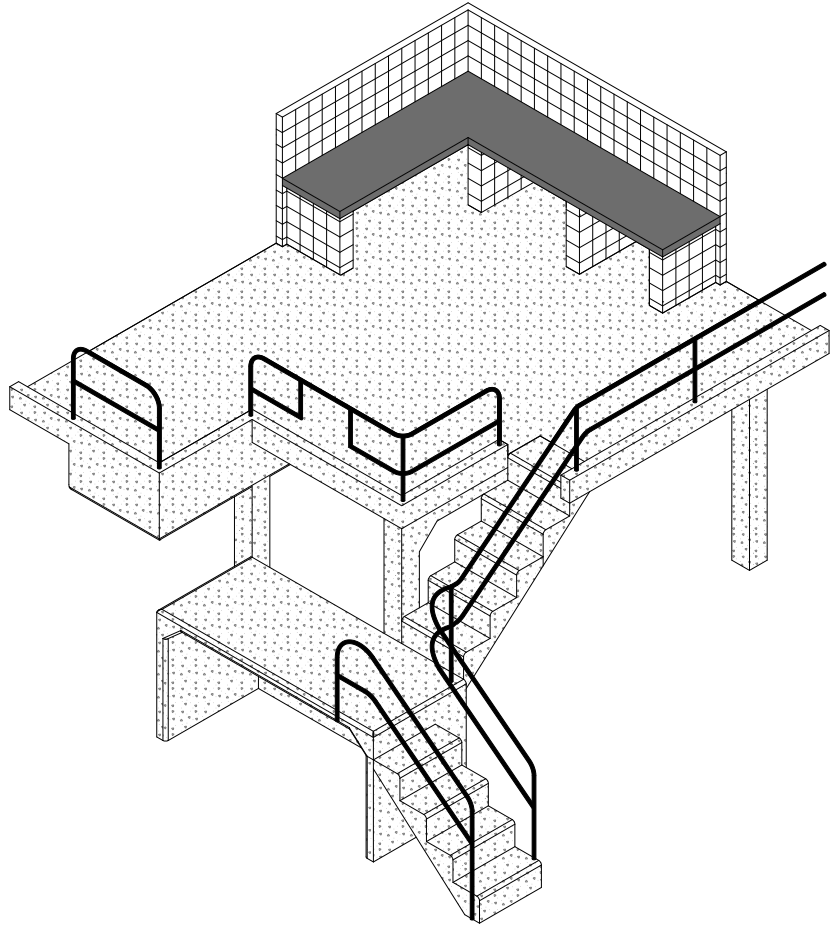

transformation

office

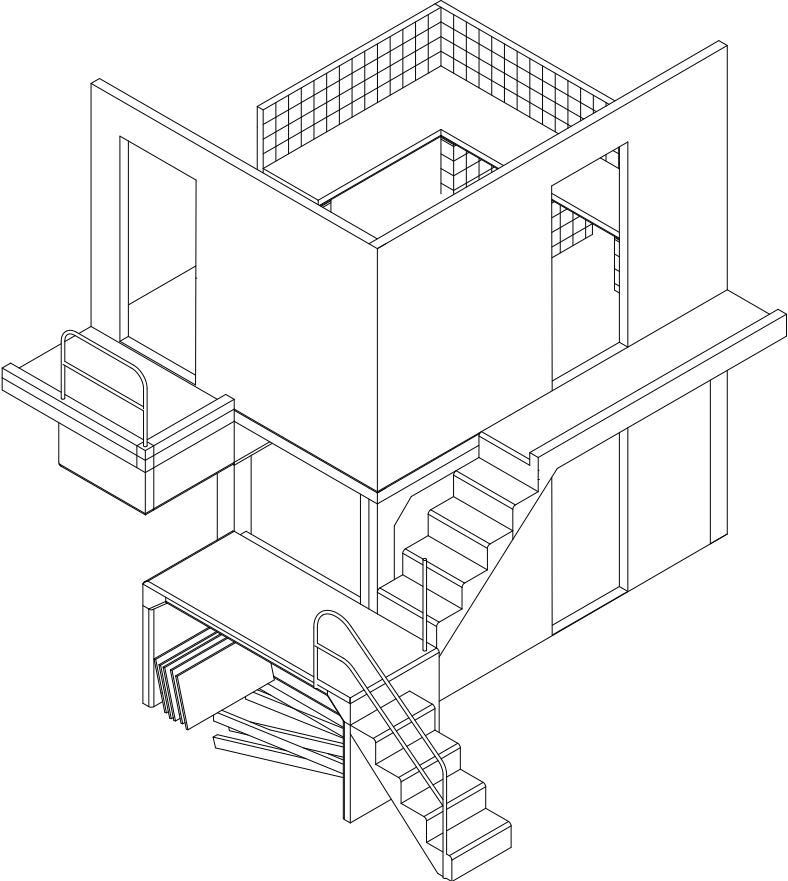





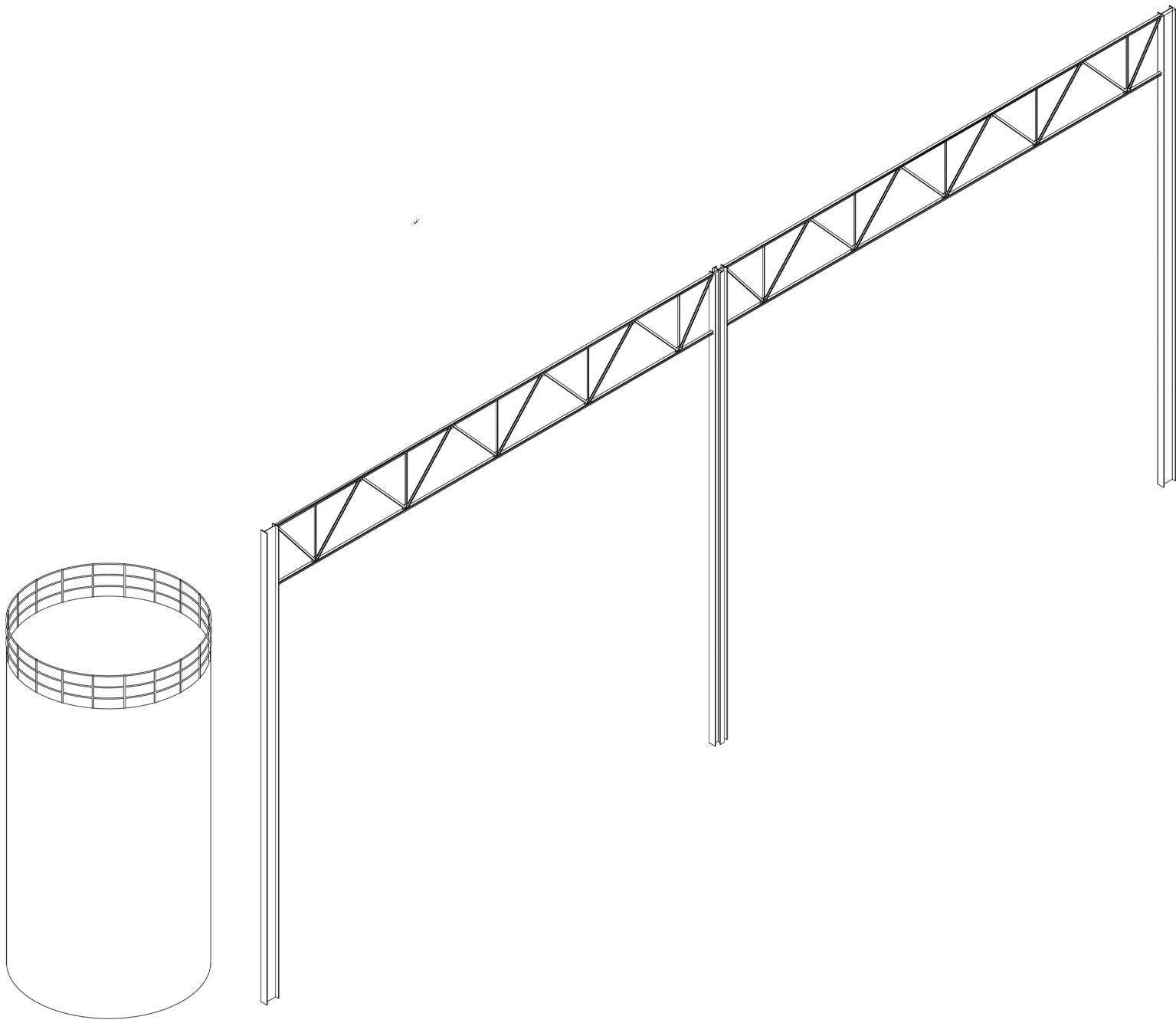





USER 1  
URBAN RESIDENT



USER 2  
MAKER



USER 3  
WORKER



USER 4  
STUDENT

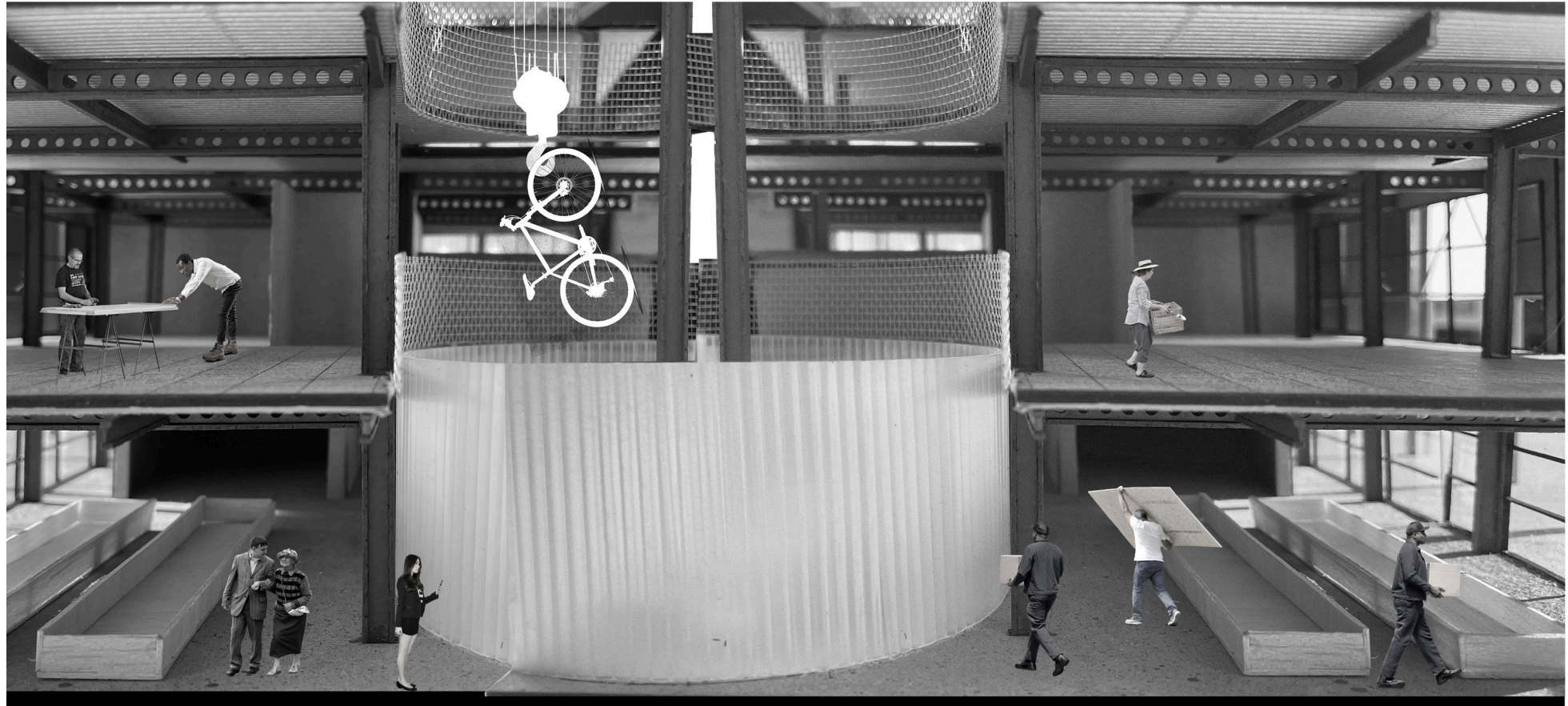

hybrid spaces

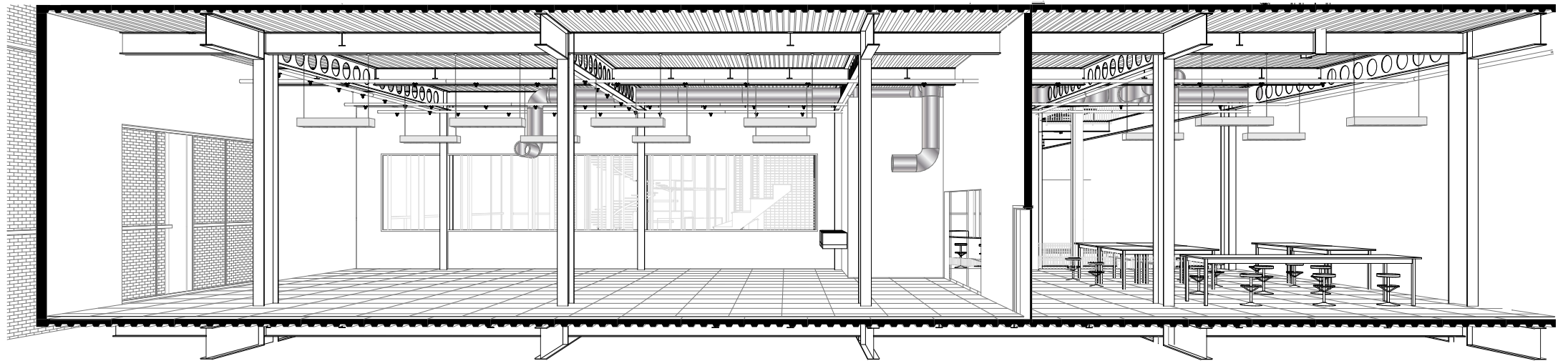

hybrid spaces

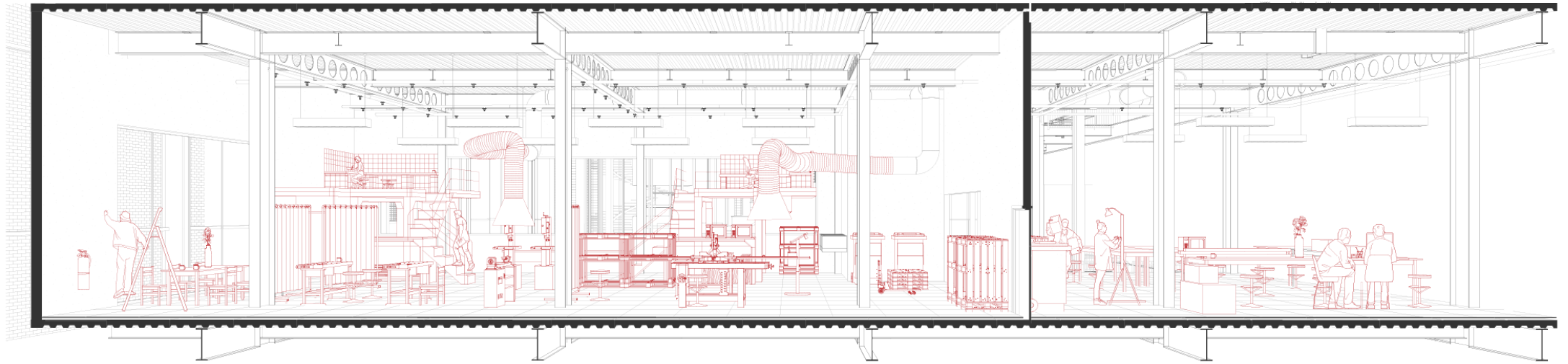

hybrid spaces

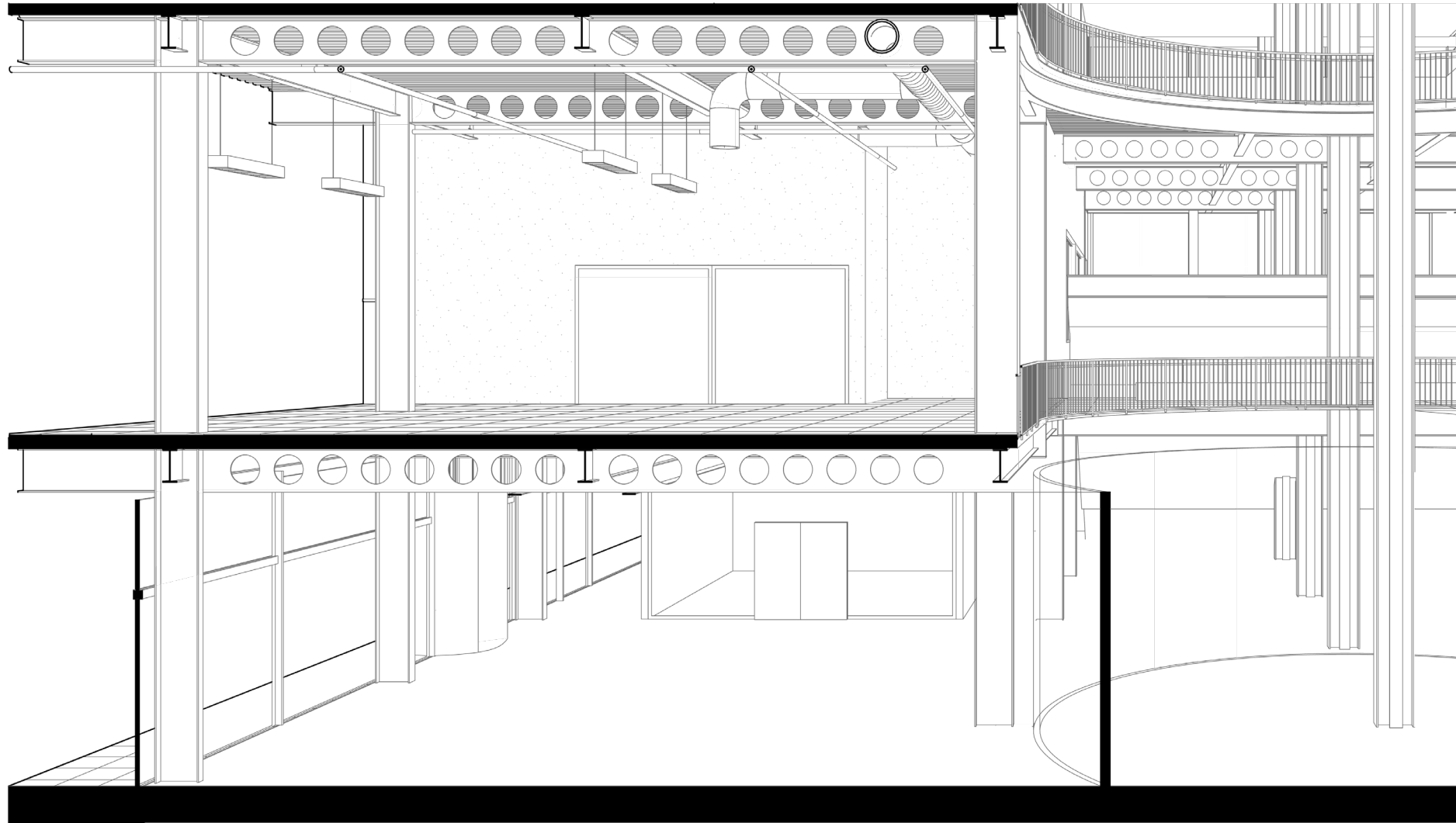

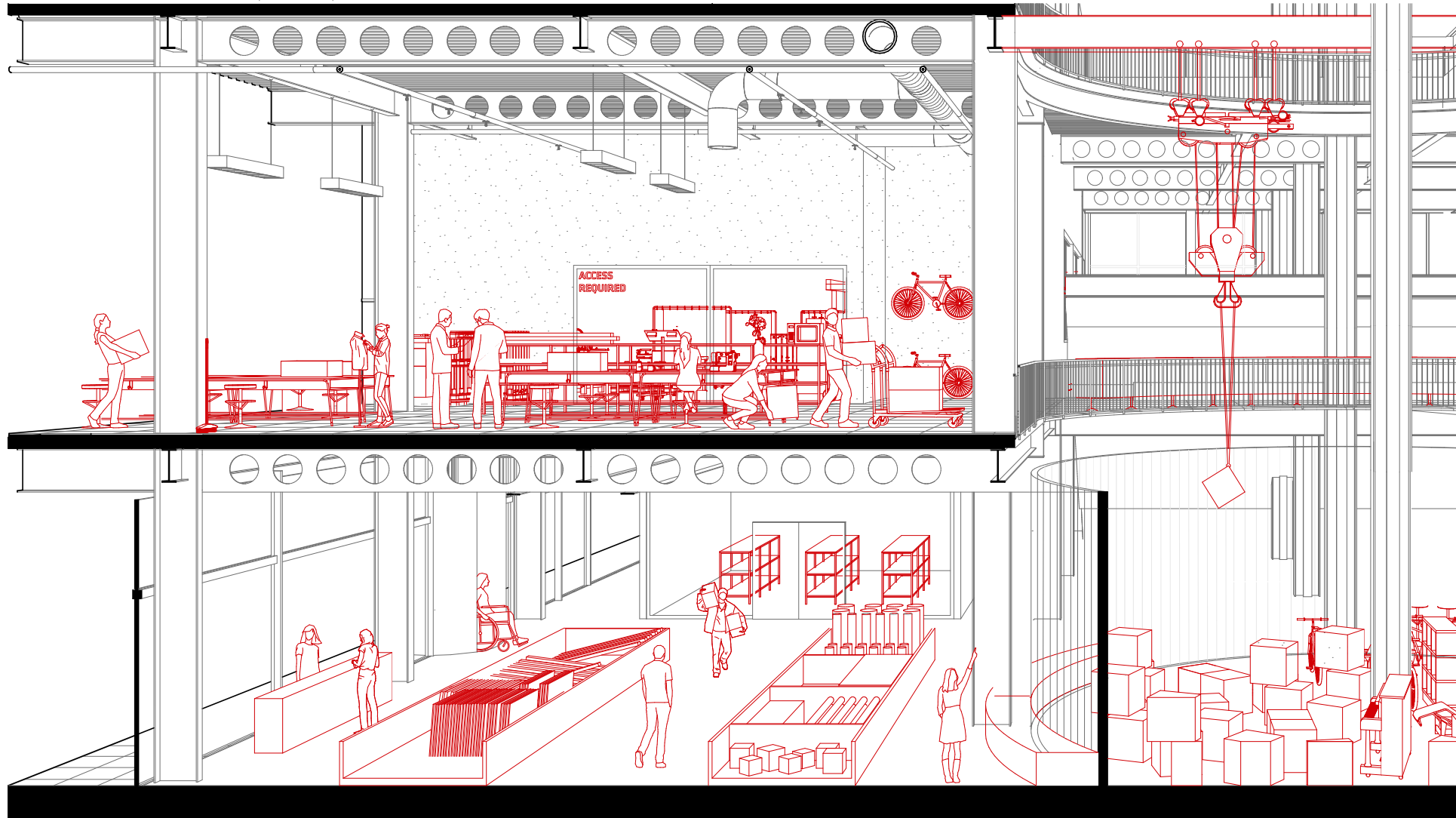

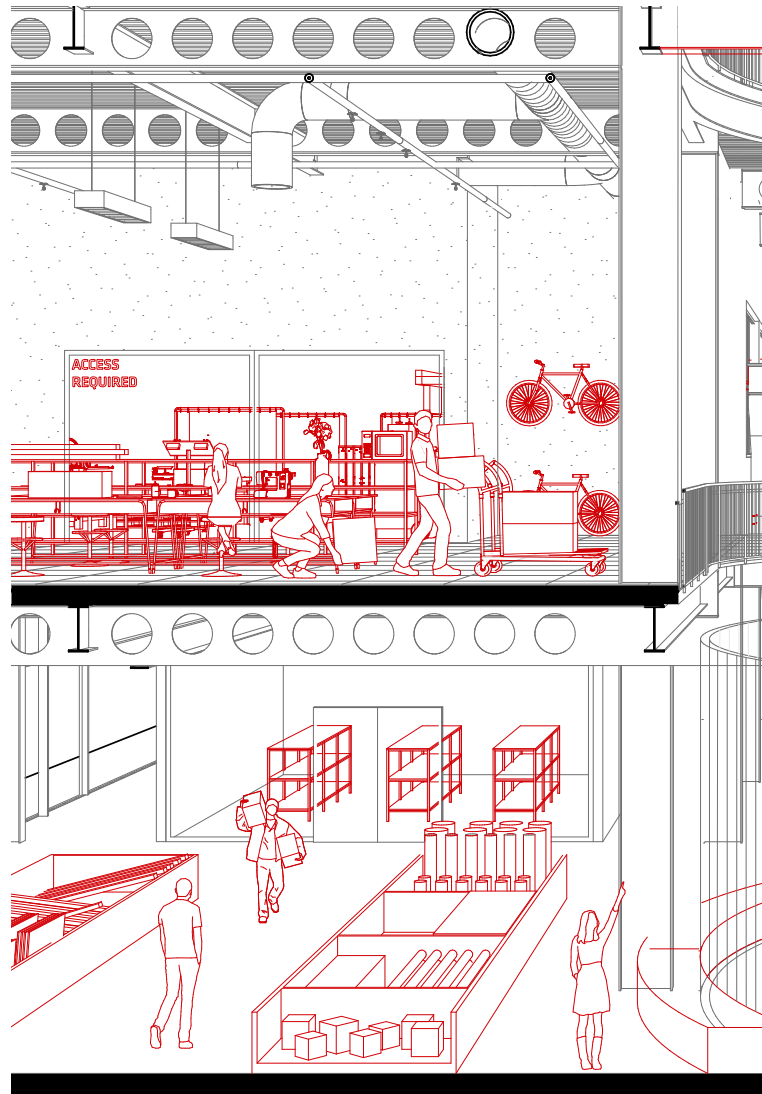

# PEOPLE CELEBRATE PRODUCTION

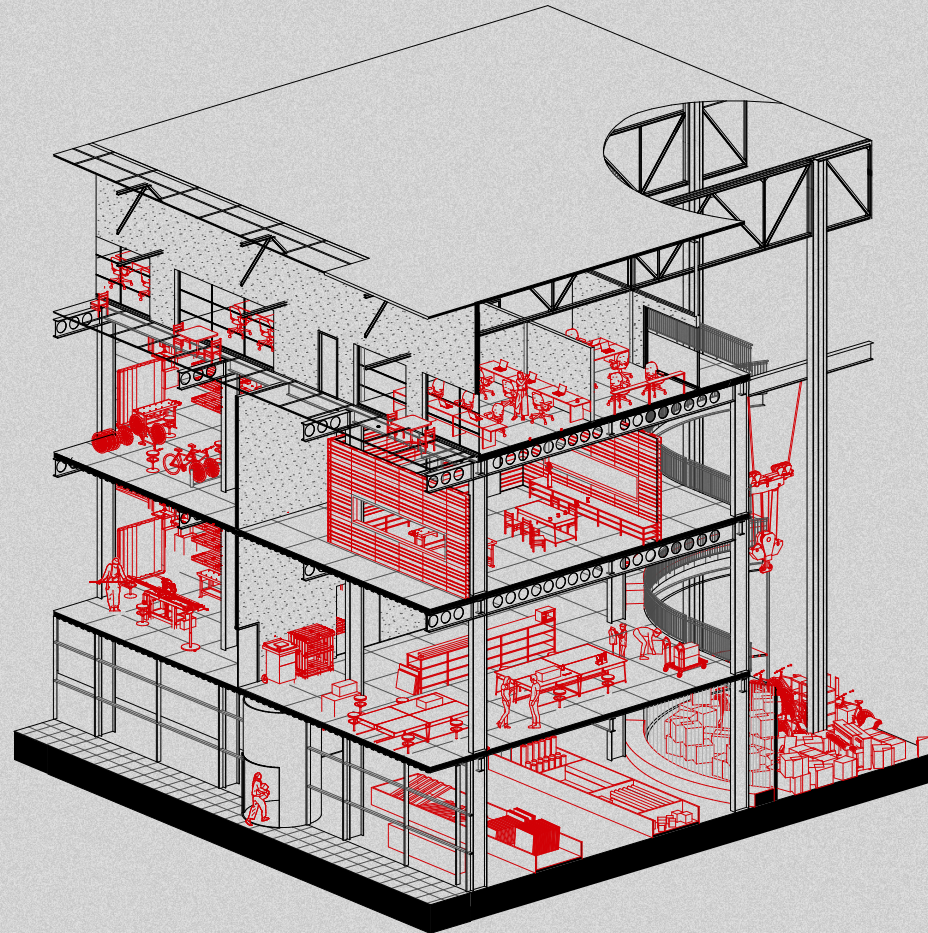

barrier beam bicycle broom brush cabinet cable tray chair columns crane hook drill dust collector face shield first aid kit forklift glue hammer hand saw human ladder  
laptop local exhaust microwave mug partitions pencil phone plier safety glass safety gloves scissors sewing machine screw screwdriver silos sink sponge stool table trash bin  
tripod trolley truss vase ventilation pipes water bottle warning signs wooden palette wood working table

reflection

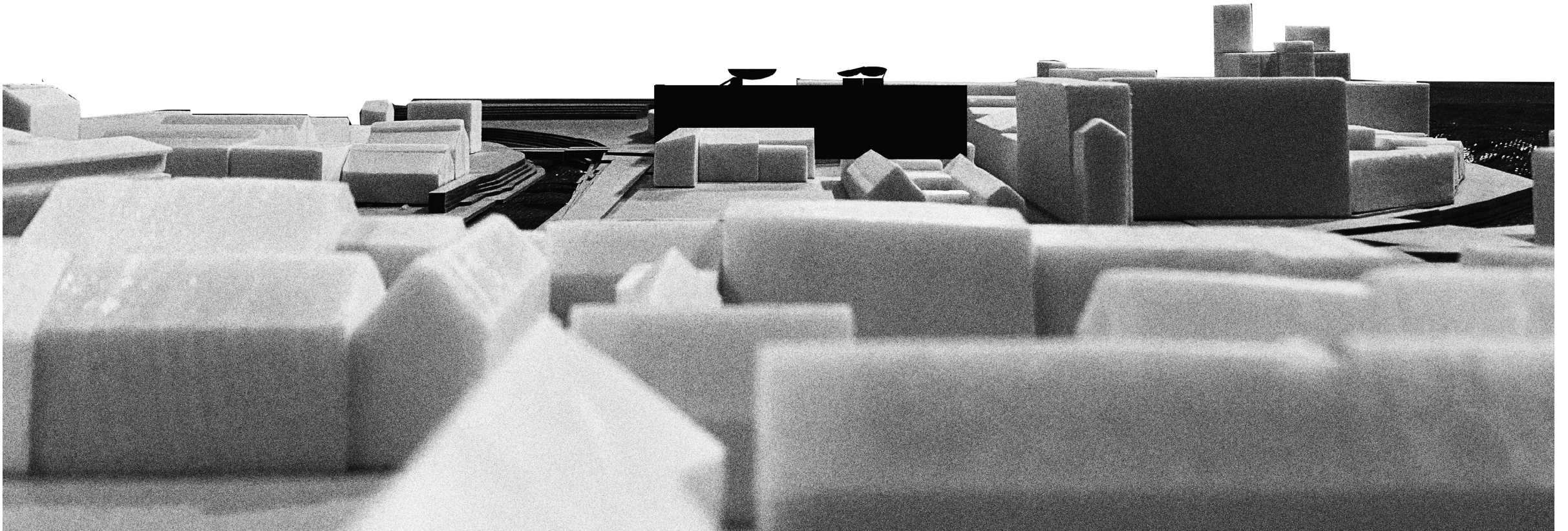

thank you