

Recommendations for assessing and upgrading old urban quay walls

Alfred ROUBOS

Hydraulic engineer,
Engineering Dept.
Municipality of Rotterdam,
Rotterdam, Netherlands
aa.roubos@rotterdam.nl

Alfred, born 1983, received his civil engineering degree from Delft University of Technology in 2006.



Jarit DE GIJT

Assistant Professor Delft
University and
senior consultant,
Engineering Dept.,
Rotterdam, Netherlands
jg.degijt@rotterdam.nl

Jarit, born 1947, is
Ass. Professor since 2004 at Delft
University of Technology

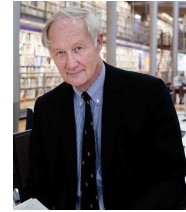

Summary

From the earliest days, quay walls have played an essential role in the shipment of goods in the Netherlands. Therefore the relative old cities have historic quay wall structures. During the life time of these quay walls, the structures have been exposed to various loads due to changing boundary conditions. Currently there is no specific guideline for determining the minimal required safety of these old and historic structures. A specific point of interest is describing the methods and the extension of an inspection in urban areas.

Therefore an expert group is preparing a guideline for upgrading and analysing old quay walls in urban areas. This guideline is called “CUR recommendation C186”, In this CUR recommendation a design philosophy and practical guidelines for inspection protocols and verification are presented. The verification of the remaining life time in relation to the latest developments will be in line with the standardisation of the new Euro codes and national appendixes. Nowadays many urban quay walls are used for other purposes compared to their originally functional requirements. The quay walls have to withstand loads due to traffic and trees and have often a monumental functions. The quay walls are a part of the urban landscape in the city centres. Adaptation is necessary and commonly the execution of these adaptations will take place in highly populated areas. For these complex situations, adaptations and execution (near trees for example), practical recommendations are described.

Keywords: old urban quay walls, inspection, inspection protocols, verification, upgrading, assessing.

1. Introduction

From the earliest days, quay walls have played an essential role in the transshipment and in the transport of goods. The design and construction of quays is relative complex, because all disciplines of civil engineering are involved and the users and management of the quay walls also have specific demands and requirements. The oldest quays wall in Rotterdam date from the beginning of the 17th century. The oldest quay was made for a harbour reserved for fishing boats. In those days the ships needed a water depth of around 5 metres, but it was impossible to obtain a greater retaining height than 2.50 meter. For this reason the ships were moored to a row of wooden mooring piles at some distance from the quay where they were loaded and unloaded as illustrated in figure 1.

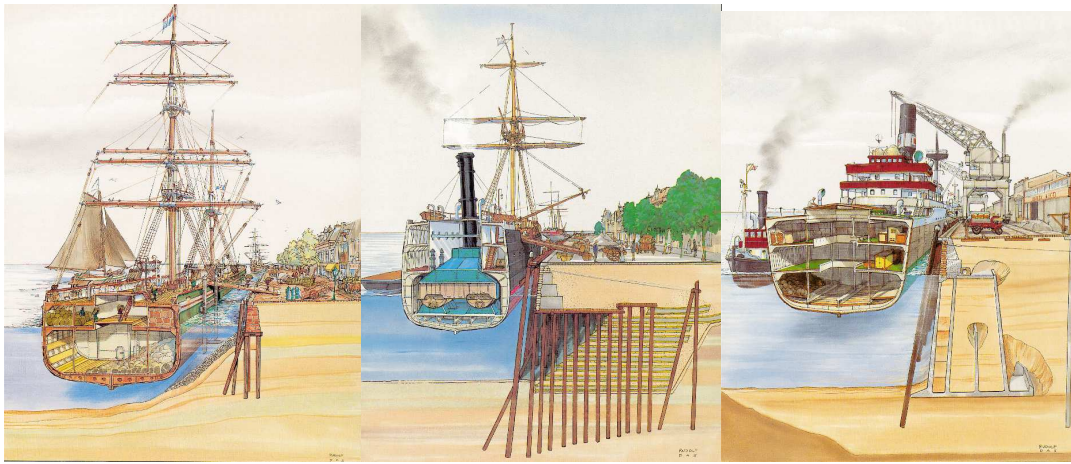

Figure 1 Old urban quay walls in Rotterdam

The quays were built of masonry walls on a wooden grillage. The difficulties encountered by the builders at that time were certainly challenging. The port areas were usually raised by using material obtained by dredging the harbour basin. This was unconsolidated weak clay. Angles of internal friction of 25° to 5° were not unusual and the weight-density was not much greater than that of water: 1.04 to 1.70 kN/m^3 . The subsoil was so weak that the quays gradually subsided into the weak clay and peat layers. The raising of the ground level caused excess pore pressure and, because of the poor permeability of the soil, it was several decades before the ground was sufficiently consolidated to provide any bearing. Settlements of 1 to 2.5 metres were no exception at that time and during dredging major sliding was the order of the day. Despite this quays were constructed successfully. In this way the quay walls in the oldest harbours of Rotterdam, the Leuvehaven, Wijnhaven and Haringvliet, came into use. In time the port activities in Rotterdam shifted more and more to the west part of Rotterdam. At the moment a large port expansion called Maasvlakte 2 is under construction. Therefore almost no port activities are carried out in the urban city centres.

The design of these quay walls have been performed in the past using the overall safety principle, also called the level 0 approach. In some historic cases the structures were not computed at all and just based on trial and error.

It appeared that a many of Dutch cities have their own perception and approach in redesigning these old structures. This is an unwanted situation. Especially for the construction companies in a tender process. This has been one of the main reasons to initiate this CUR commission and prepare a clear guideline.

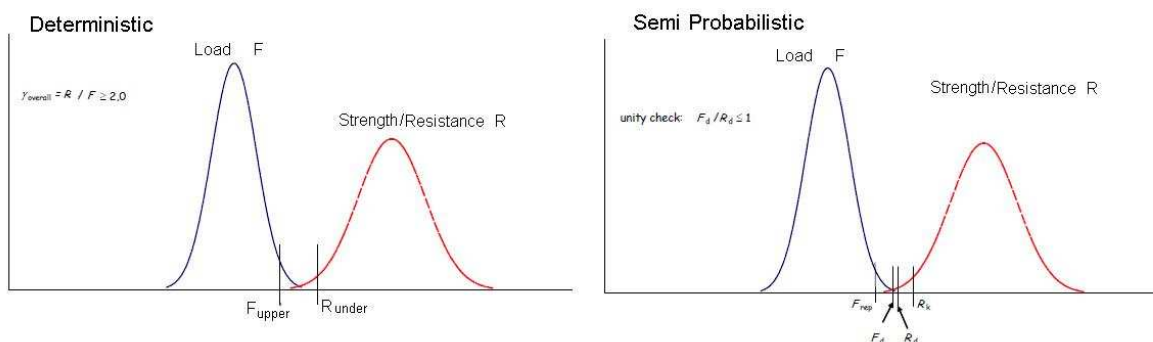

Figure 2 Deterministic and semi-probabilistic approach

Within the process of realisation of the CUR C186 guideline the overall approach of how to proceed with maintenance and redesign stage is adapted to a semi-probabilistic approach. The preparation of CUR C186 coincides with the preparation of the update of the Handbook Quay Walls

(CUR 211). The upgrade of this handbook is necessary because of the interaction with the Eurocodes and the semi-probabilistic approach. Both CUR recommendations use the same partial safety factors which are required to perform a semi probabilistic analysis.

2. Examples of typical old Dutch quay wall structures

In the CUR commission C186 various municipals are involved. Almost all municipals have a wide range of quay walls in their asset management area. The CUR commission asked all municipals to deliver information about their assets. In figure 3 the length in km and age in years of the urban quay walls in Rotterdam is displayed.

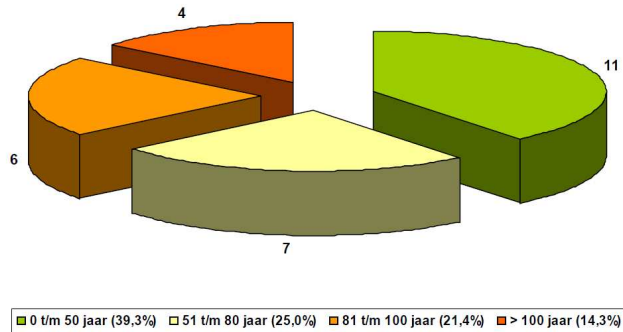

Figure 3 Overview urban quay walls in Rotterdam

It appeared that the traceability of old contract, requirements and drawing is often hard to derive. Some asset managers doesn't have enough insight in the total condition of their assets. For these asset managers a special inspection class 0 is distinguished to verify the current condition and geometry of the structures. Figure 4 gives an impression of these old drawings of the structures.

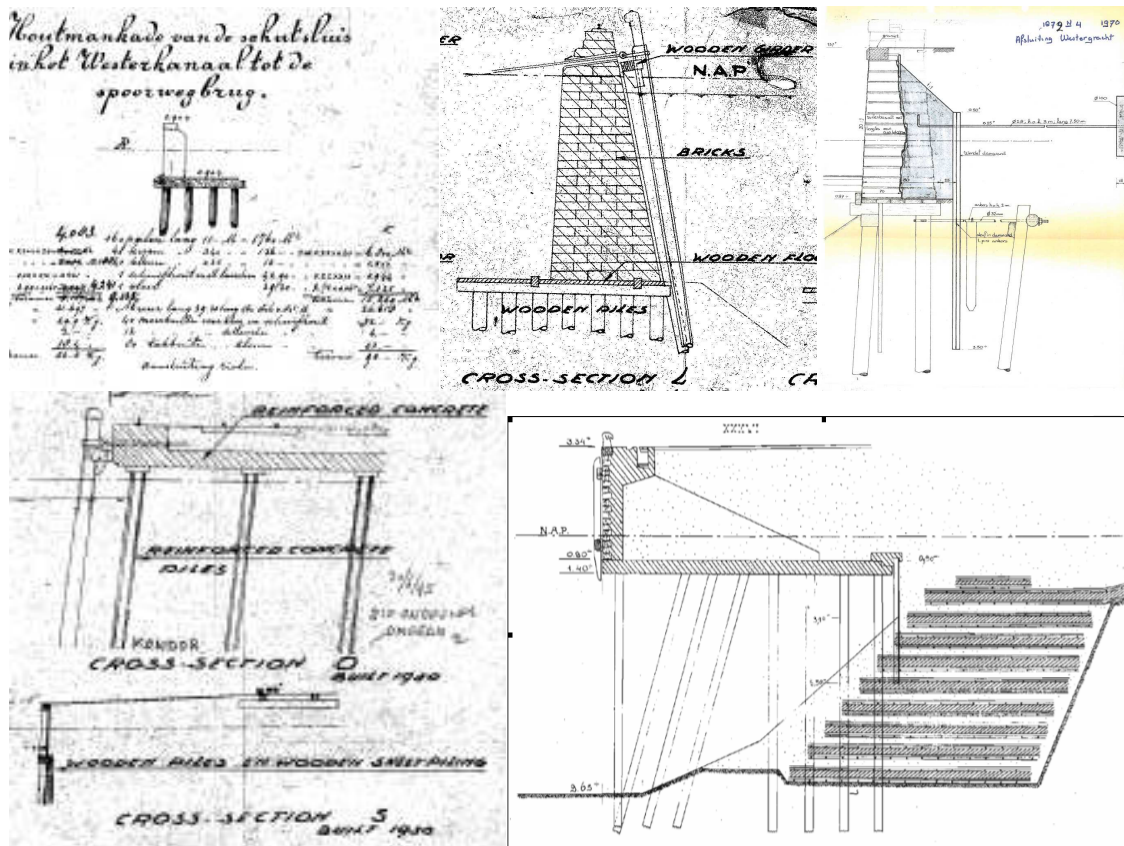

Figure 4 Municipality data collection: historic quay walls

Almost all municipalities delivered a lot of information about their historic hydraulic structures. After receiving all the data 4 main types of urban quay walls are distinguished.

1. gravity wall;
2. gravity structure on pile foundation;
3. relieving structure with pile foundation;
4. sheet pile structure.

The quay walls have different critical objects and have different failure mechanism. Special attention must be paid to quay walls with wooden relieving floor of retaining structure. Large scour holes may occur at the active soil side of the quay wall. This situation doesn't directly lead to instability of the quay wall but can cause a sudden scour hole. This is extremely dangerous for traffic directly behind the structure and can result in a deadly accident. In case of in section special attention needs to be paid to the wooden pile foundation. It is likely that the foundations are built with wooden piles that can originate from different trees. The CUR recommendation gives insight for the asset managers and the engineers how to deal with degradation of these aspects. In the figure 5-7 the different failure mechanism are visualised.

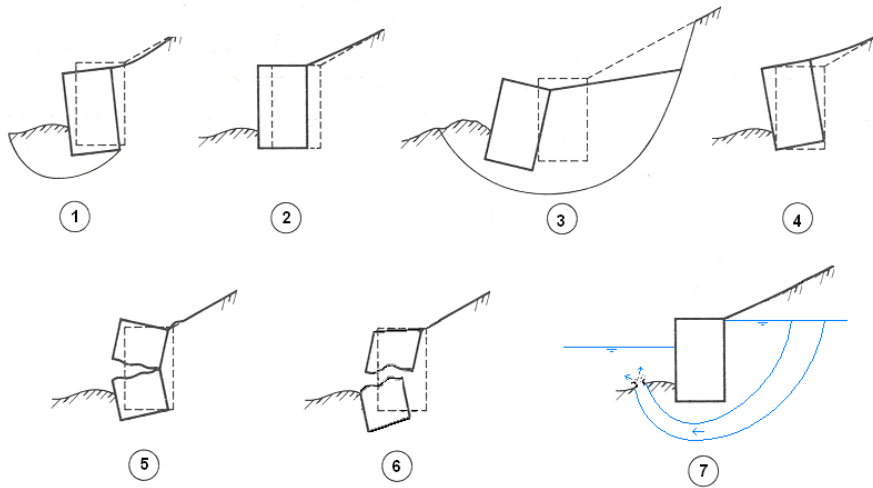

Figure 5 Type 1: Failure mechanism gravity wall

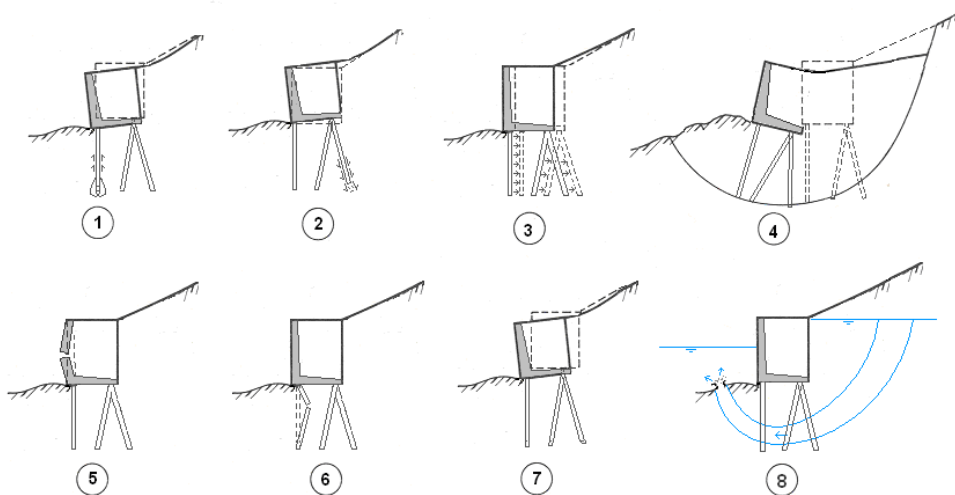

Figure 6 Type 2 and 3: Failure mechanism gravity wall and relieving floor with pile foundation

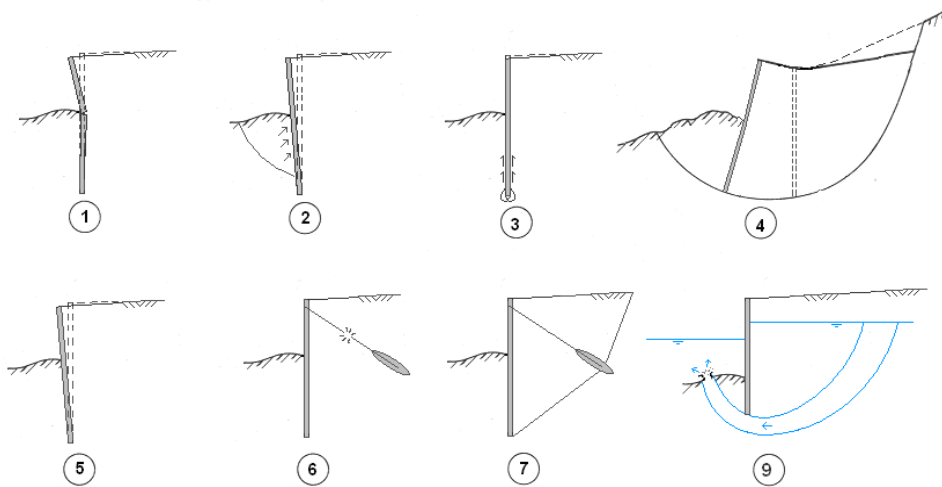

Figure 7 Type 4: Failure mechanism sheet pile wall

3. Initial data for assessment

Especially in urban areas and during the redesign of quay walls in old city centres severe factors are important to obtain an optimal design. The most important design aspects are listed below:

- Soil conditions: When refurbishing old structures it is very important to know the soil conditions. With this information a proper adaptation of existing foundations can be made.
- Variation in water levels. On retaining structures both soil and water pressure exert loads. So it is also very important to know the variation in water levels
- The loading conditions: In time the functional requirements of urban quay walls are changed. The loads due to transshipment are not so dominant any more. Loads due to traffic and trees have become much more important.
- Condition of the structure: With visual inspection and more advanced inspection methods the condition of the structures is established.
- Planning: A relative short execution period and therefore the total hindrance for the surrounding is very important in urban areas.
- Monumental aspect: For national monuments special legislation is applicable.
- Critical parts of structure: Each type of structure has its strong and weak points
- Structural integrity: The present structural integrity is checked by making computations of the different failure mechanisms of the structure using the semi probabilistic design approach. Based on these calculations decisions can be made between refurbishment in relation to the lifetime and safety and cost of maintenance, repair or building a complete new structure.



- Environmental issues: Due to negligence of the asset manager flora and fauna has grown in the masonry of the relative old quay walls. According to recent changes in legislation flora and fauna needs to be paced back in future designs. In figure 8 an example of flora is presented which is very often present at the face of old urban quay walls.

Figure 8 Flora and fauna on historic quay walls

4. Inspection protocol

During a tender process for the regular inspections of a quay wall in a certain assets it is very important to describe the inspection protocol accurate. Therefore an asset manager needs to have insight in various types of inspections and in necessary amount of research. For example is it necessary to investigate all the wooden piles on a quay wall or is it enough to investigate a certain amount of piles per section. This depends on the type of structure and on the objective of the inspection. Because each quay wall is different it is relative hard to prescribe an uniform inspection protocol for all urban structures. Therefore an other strategy is has been chosen. Almost all quay walls are made of masonry, concrete, wood or steel. Therefore the inspections and investigations are lubricated to the materials. In NEN 2776 a method is presented to rank the assets in an area. This can result in a quick-scan of the total asset area, but not in detailed insight in the degradation process. In this CUR recommendation there are 4 inspection classes distinguished. The asset manager can use these classes in a tender process.

Table1 Classification of inspections

Class	Title	Frequency	Objective
0	Initial inspection geometry	Once	Update asset administration
1a	Measurements of deformations	1 x year	Verify stability o
1b	Visual inspection	2 x year	Verify functionality and safety
2	Technical inspection (light)	1 x 5 years	Determination condition
3	Technical inspection (detailed)	-	Preparation for detailed calculations for assessing
4	Other investigations (specific)	-	For example to discover cause damage

To enlarge the insight of the asset manager and to create uniformity between municipalities several methods for investigation are described in detail in this CUR recommendation. With this chapter the expert group is willing to ensure that inspections are carried on regular basis during the design life time of a urban quay wall. An other objective is that inspection class 0 can be used tot update the asset administration in case important files are still missing. The inspection results needs to be documented in a asses administration system. This system will become the basis of the assess analysis during the life time of a hydraulic structure and needs to be complete before refurbishing a quay wall.



Figure 9 Photographs of damage discovered by a visual inspection (class 1b)

5. Assessing historic quay walls

The assessment of urban quay wall is a complex process. In the Netherlands there is a lot of experience with the assessment of the preliminary flood defence system. The expert group thinks that this system also can be applied to the urban quay wall. Compared with other structures the old urban quay walls relative few maintenance during the design life time. Normally quay walls have a design life time of 50 years. After these period a quay wall needs to full fill the requirements and functionalities. In time the functional requirements of urban quay walls are changed. The hydraulic and surface loads due to transshipment are not so dominant any more. Loads due to traffic and trees have become much more important.

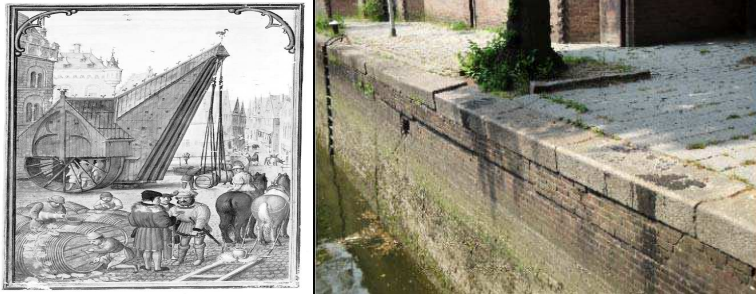

Figure 10 Change in loading conditions during the life time of old quay walls in city centres

The assessment starts with a relative simple approach. Due to functional changes sometimes no recalculations are necessary to guarantee safety and stability. When a simple analysis is not possible more detailed calculations needs to be carried out. This results in an interface between the inspection protocols and an assessment. Depending of the results from this inspection more complex analysis can be performed, for example a calculation with finite element analysis. Another possibility is the principle of “proven stability during extreme conditions”. Maybe the extreme loads already occurred during the life time, but the validation of this process is very complex and intensive. Quay walls are classified in reliability class RC2 according to the Euro codes, NEN8700 and NEN1990. For new structures a reliability index of 3,8 is prescribed. However to guarantee the safety and stability of an existing quay wall a reliability index of 2,5 is valid. The factor corresponds with a time period of 1 year qua strength a with a return period of 15 years for loads.

Table2 Reliability classes for existing structures

Probability		NEN 8700 Assessment of existing structures		NEN 8700 Upgrade existing structures		EN 1990 New structures	
Economical damage	Accidents	Class	β_{15}	Class	β_{15}	Class	β_{50}
Negligible	Small						
Negligible	Minor	RC1	1,8	RC1	2,8	RC1	3,3
Minor	Considerable						
Considerable	Large	RC2	2,5	RC2	3,3	RC2	3,8
Extremely large	Large	RC3	3,3	RC3	3,8	RC3	4,3

Experiences in Rotterdam indicate that quay walls in the city area are in use for more then 100 years while at the Maasvlakte area some quay walls have to be adapted after 15 a 20 years already. This relatively quick adaptation of quay walls is partly due to the unforeseen growth of especially container ships dimensions. In figure 11 an indication is given of the life time of quay walls in Rotterdam . Within the chemical industry the lifetime is only 4 a 5 years which is very short compared with the life time of quay walls. This is owing to the fact that in this industry they have to adapt their logistic and production facilities more frequently.

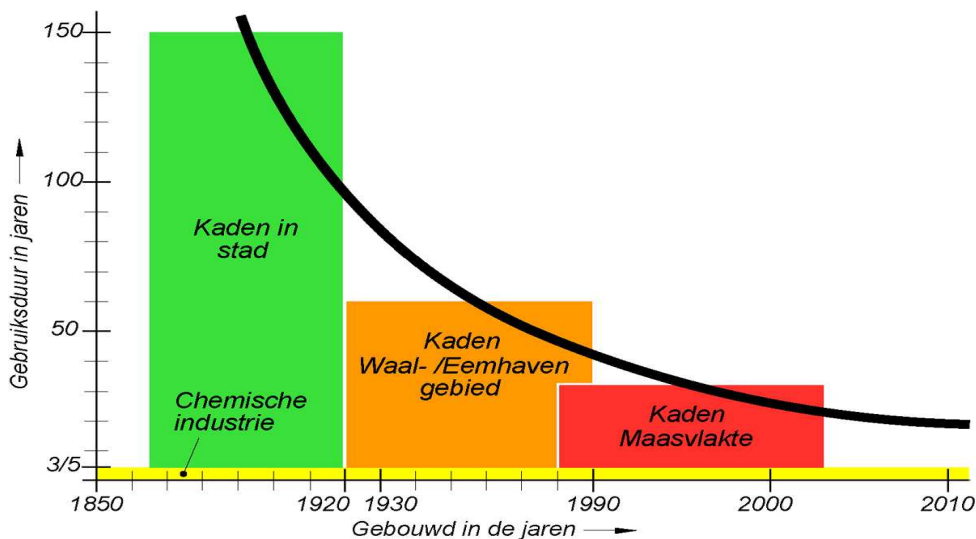

Figure 11 Service life of quay walls in Rotterdam

6. Conclusions and recommendations

- With CUR publication 186 a comprehensive guideline will be presented for upgrading and analysing old quay walls in urban areas.
- In this CUR recommendation a design philosophy and practical guidelines for inspection protocols and verification are explained.
- The verification of the remaining life time in relation to the latest developments will be in line with the standardisation of the new Euro codes and national appendixes.
- It is recommended to organize a database with case studies so that information remains available.
- More research is needed to evaluate the effects of interaction between structures.

7. References

- [1] NEN 2767-1 Condition assessment of building and installation Part 1:Methodology, NEN, Delft, 2011
- [2] NEN 2767- 4 Condition assessment Part 4:Infrastructure-Part 1 Methods, NEN, Delft, 2011
- [3] NEN 8700 Assessment of structural safety of existing structures, NEN, Delft, 2011
- [4] CUR 166 Damwandconstructies, CUR, Gouda, 2012
- [5] CUR 211E Handbook Quay Walls, CUR, Gouda, 2005

8. Acknowledgement

The members of the CUR committee 186 are thanked sincerely for their contributions