

THE GLASS DOME

Design technology for a dry assembled and cast glass dome

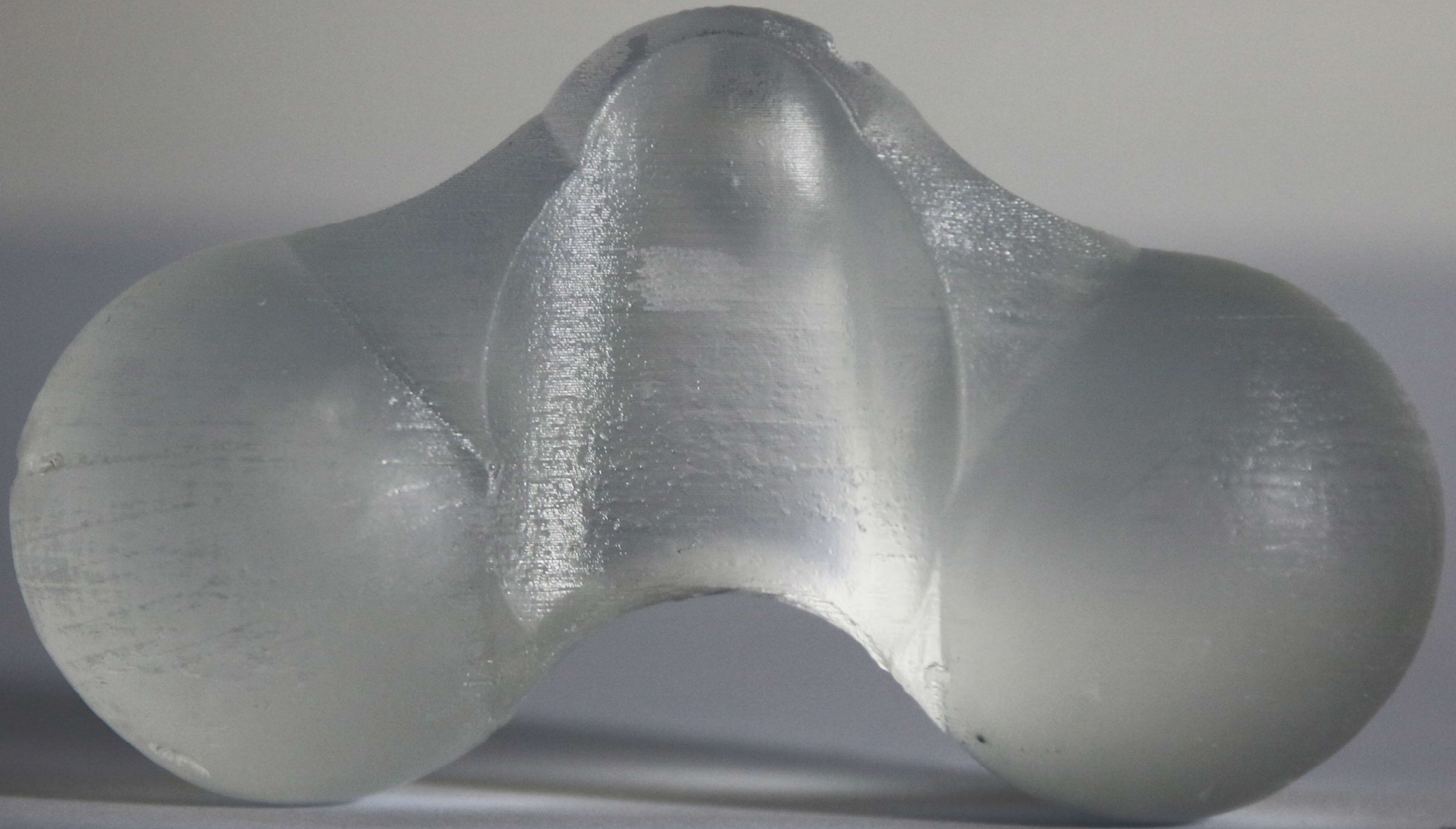



THE GLASS DOME

Mentors:

.....

- **Faidra Oikonomopoulou**
- **Regina Bokel**
- **Telesilla Bristogianni**

Motivation: *For centuries.....*



(Middle Earth Home, 2017).



(source: www.florenceforyou.com).



(source: www.tumblr.com).



(Smith, 2006).

Motivation: *The industrial revolution led to,....*



(C. Good, 1976).

Motivation: *Dome designs aim for.....*

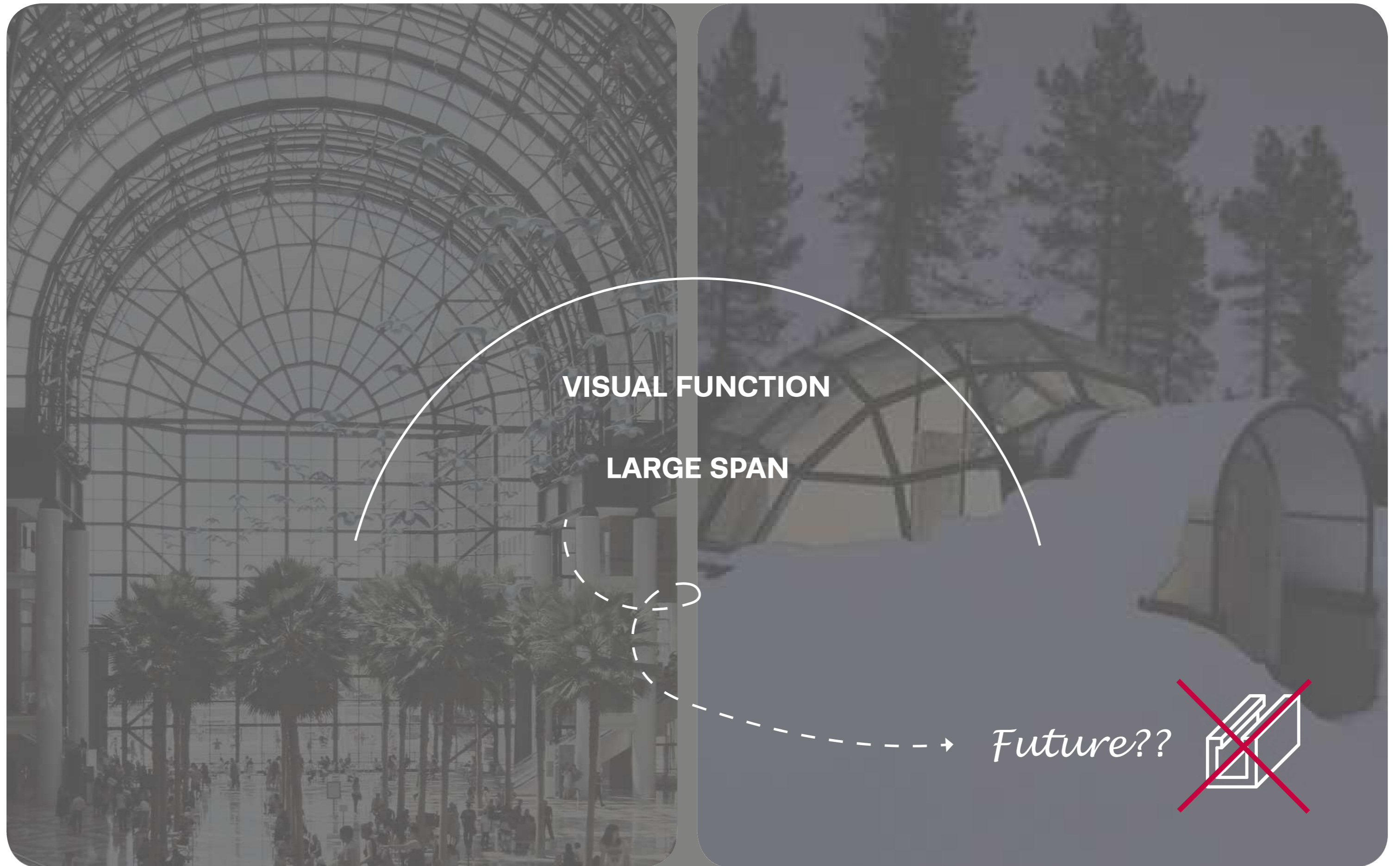

VISUAL FUNCTION

LARGE SPAN

Future??



Motivation: Evolution of the glass dome.....



1998

2002

2002

2003

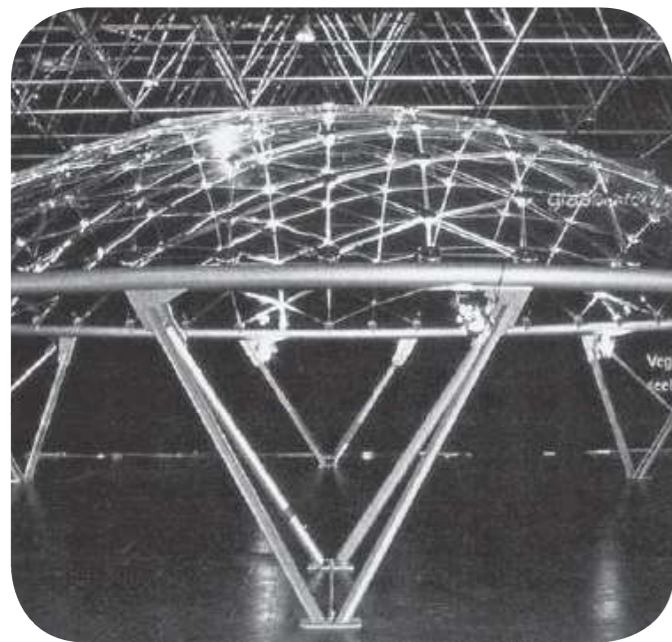

Glasstec dome (Wurm, 2007).



Delft glass dome (Wurm, 2007).

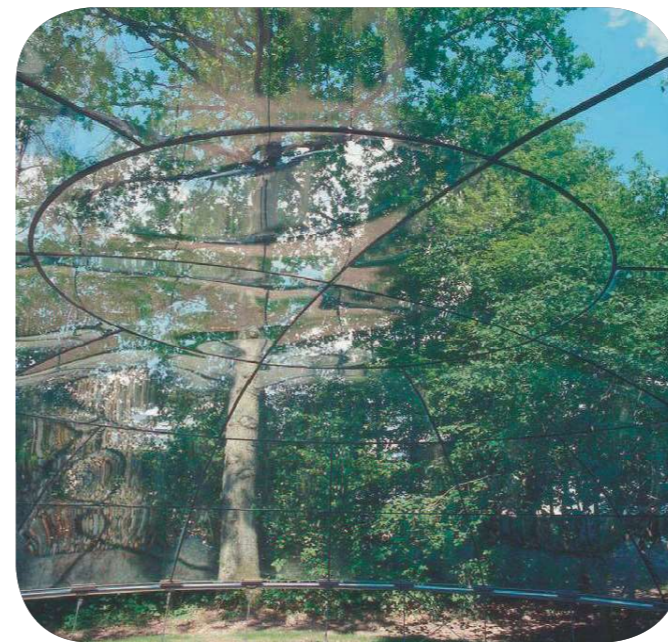

Stuttgart glass shell (Wurm, 2007).



Glasstex dome (Wurm, 2007).

Motivation: *What about the future.....*



An **all-glass** dome out of **cast glass** components



(source: www.brickowl.com)

~~TROPICAL
GREENHOUSE~~

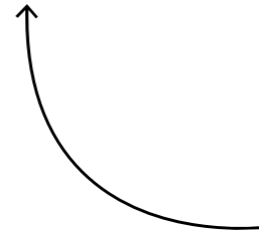

?



~~NORTHERN
LIGHTS~~

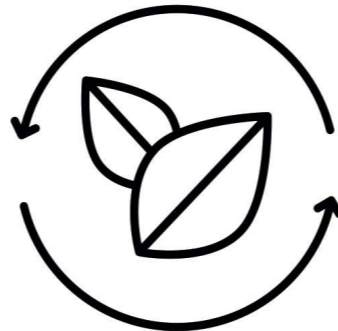

AVIARY

Motivation: *Current aviaries.....*

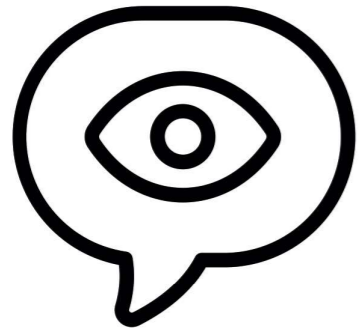

(source: www.worldarchitecturemap.or)



Motivation: South-east of France....



(source: <http://www.mon-maire.fr>).

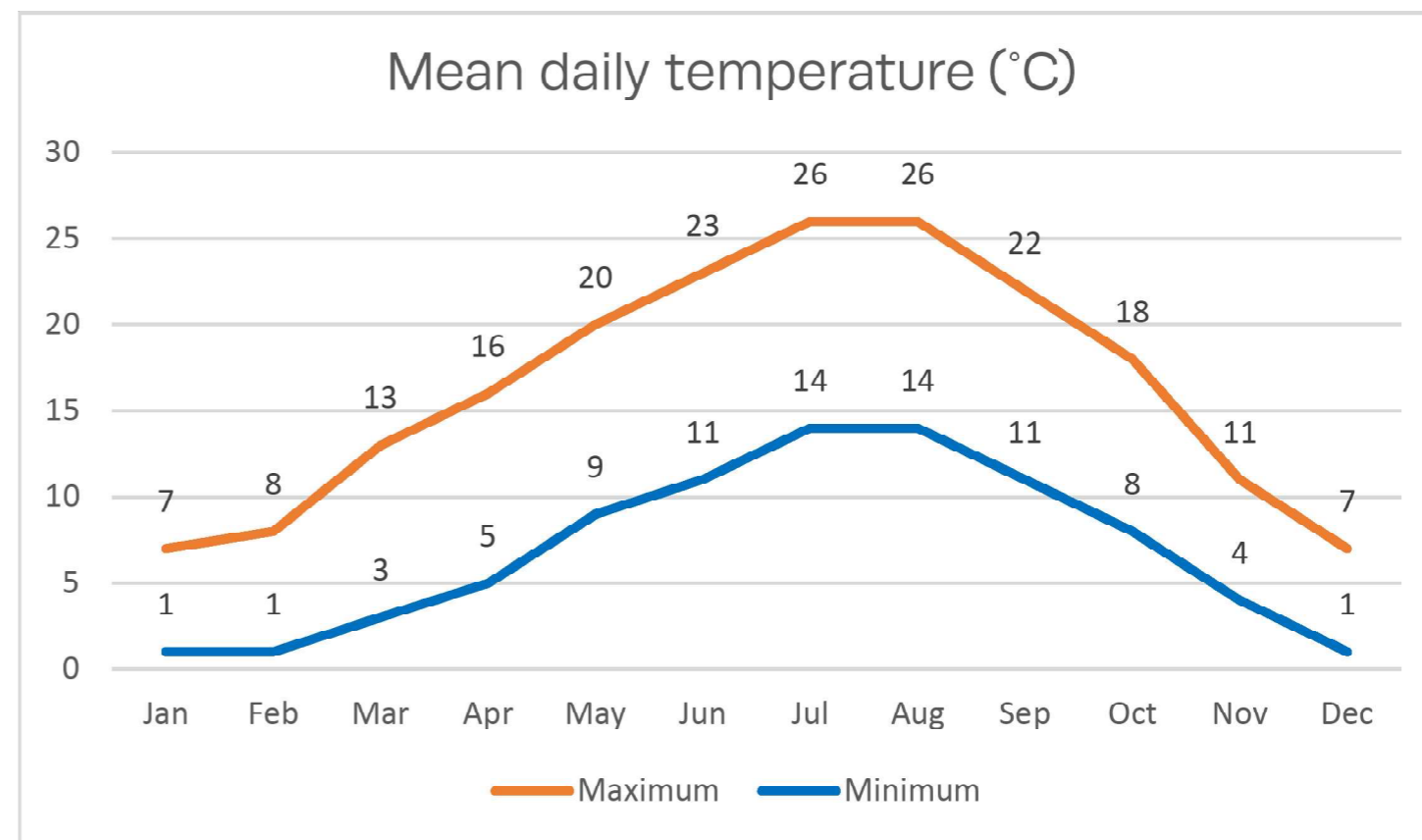

(Meteoblue, 2017)

'Villars Les Dombes'

Moderate climate

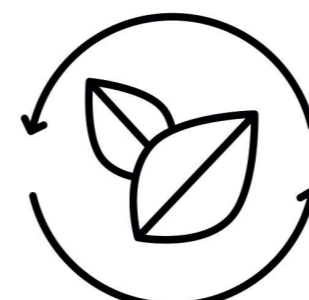
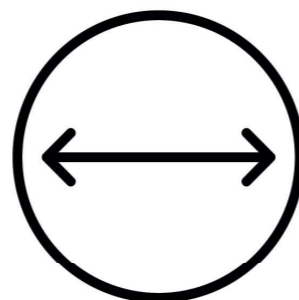

Motivation: 'Parc des Oiseaux'.....

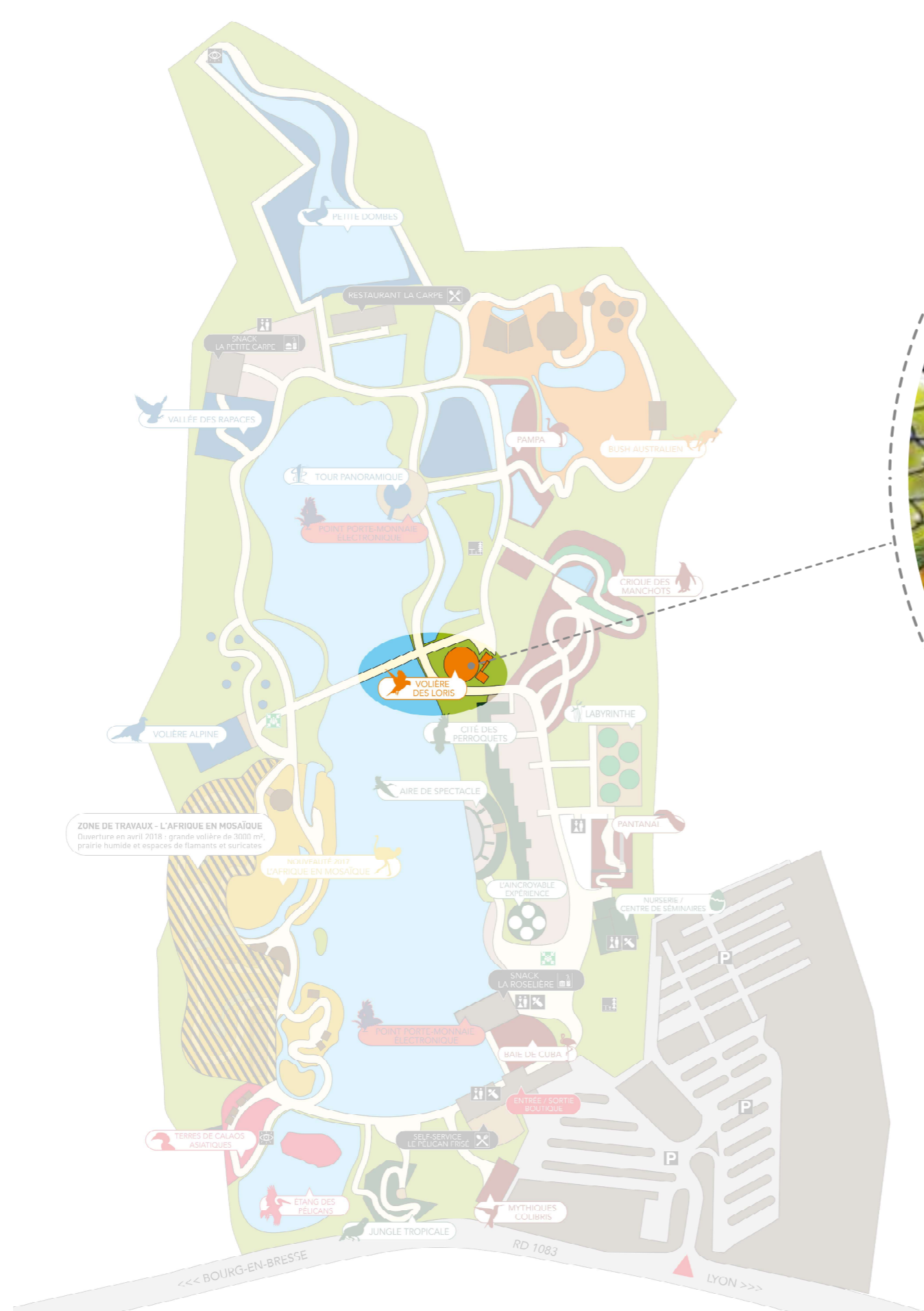

Bird park: '**Parc des Oiseaux**'
Aviary for **Lori parrots**

Main question

“How can a solely glass dome be developed and assembled from structural cast glass components while providing thermal comfort and being minimum invasive for the local environment?”.

Sub questions

- What is the **optimal shape** of the cast glass components?
- What techniques can be used to **minimize** the number of **different molds**?
- What techniques can be used to connect the components and create a **demountable structure**?
- What strategies can optimize the dome **transparency**?
- What strategies can be used to create **thermal comfort** while being **minimum invasive** for the local environment?

The idea....

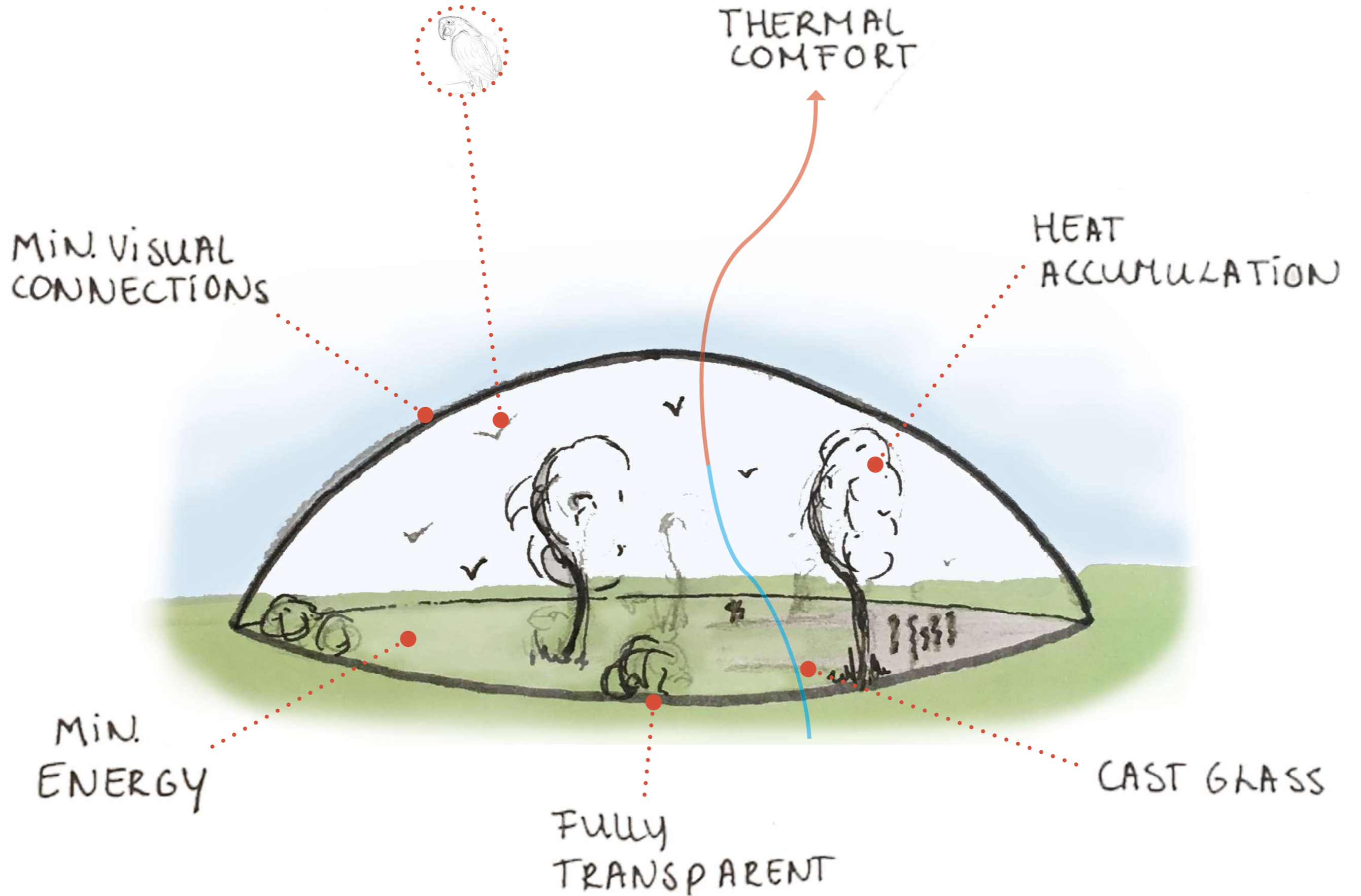

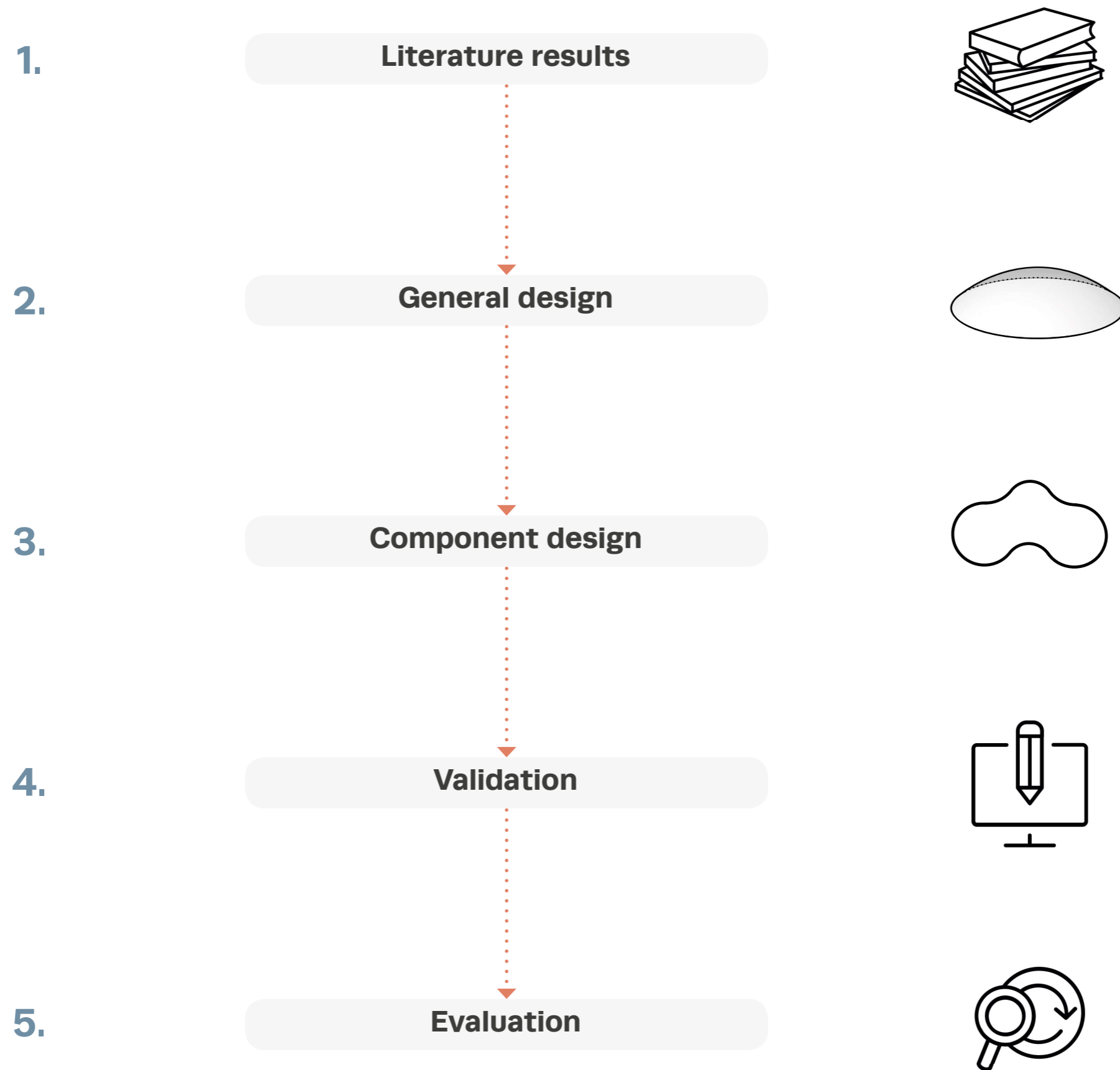

1. Literature results

Domes | Thermal performance | Glass | Interlocking systems

Domes: Compressive force system....

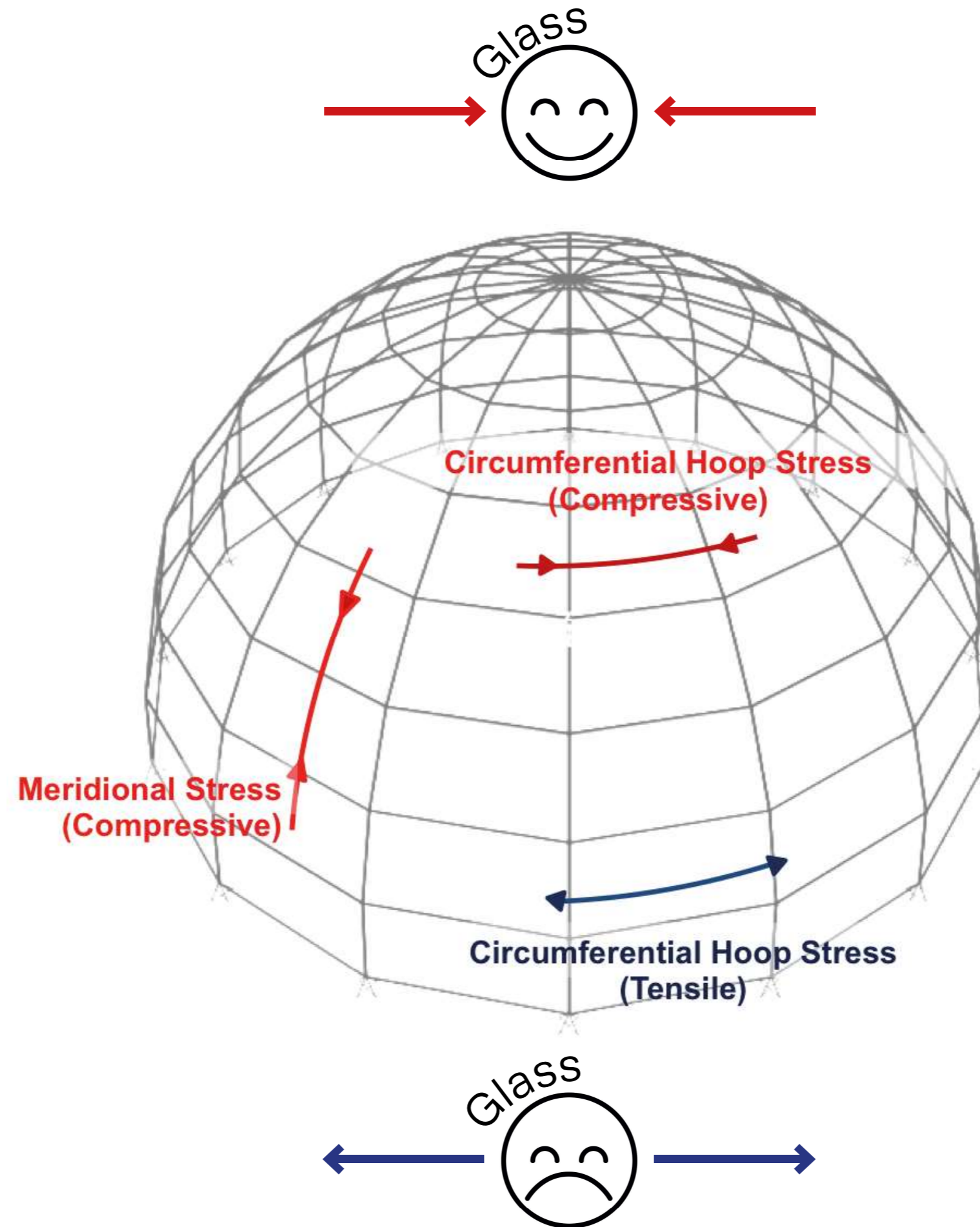

(source: <http://shells.princeton.edu/Balz.html>)

Domes: Compressive force system....

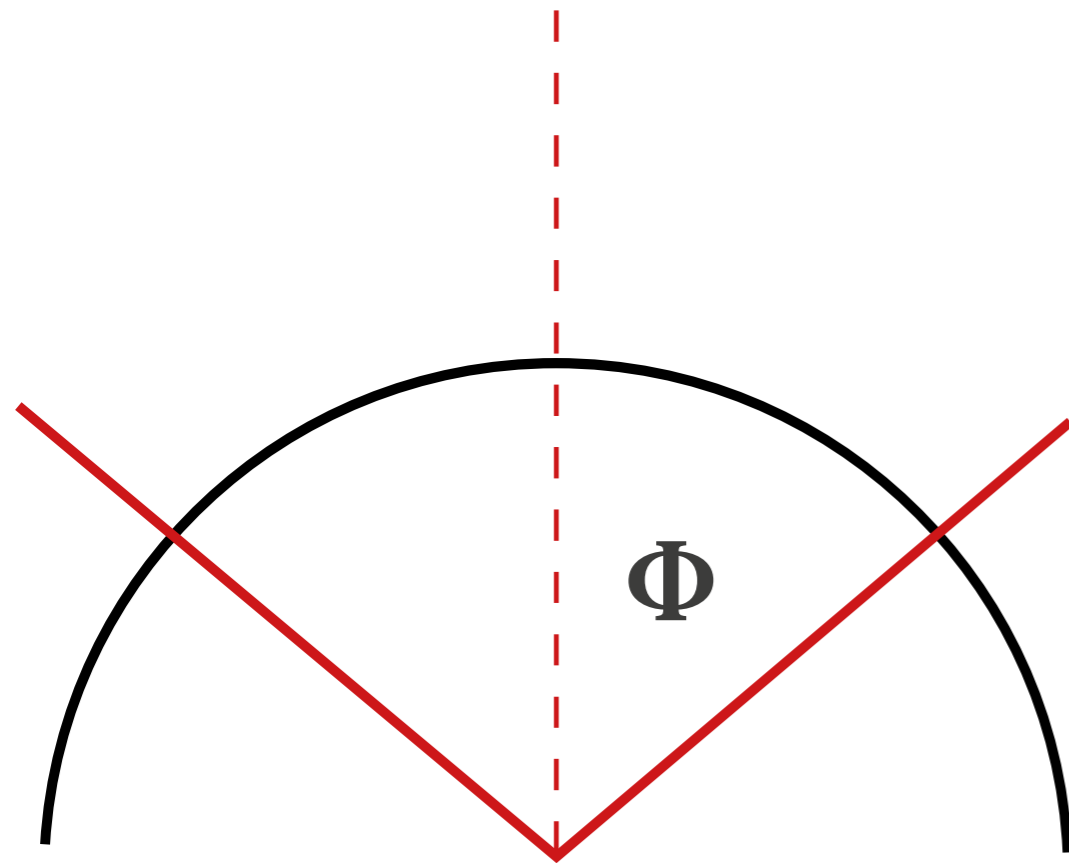

**STRESS
RESULTANTS**
.....▶

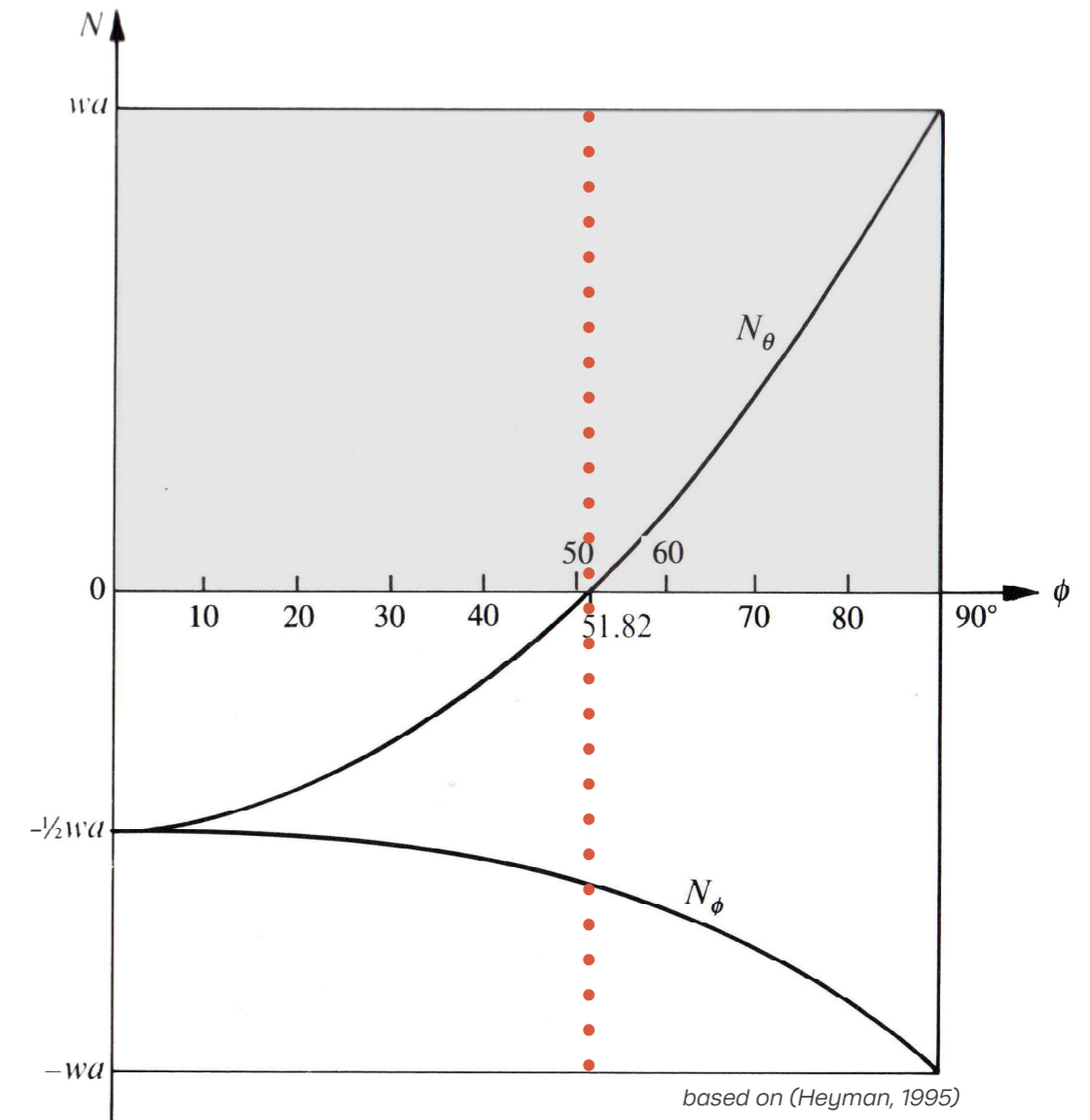

$0^\circ \leq \Phi \leq 51,82^\circ$

SHALLOW DOME

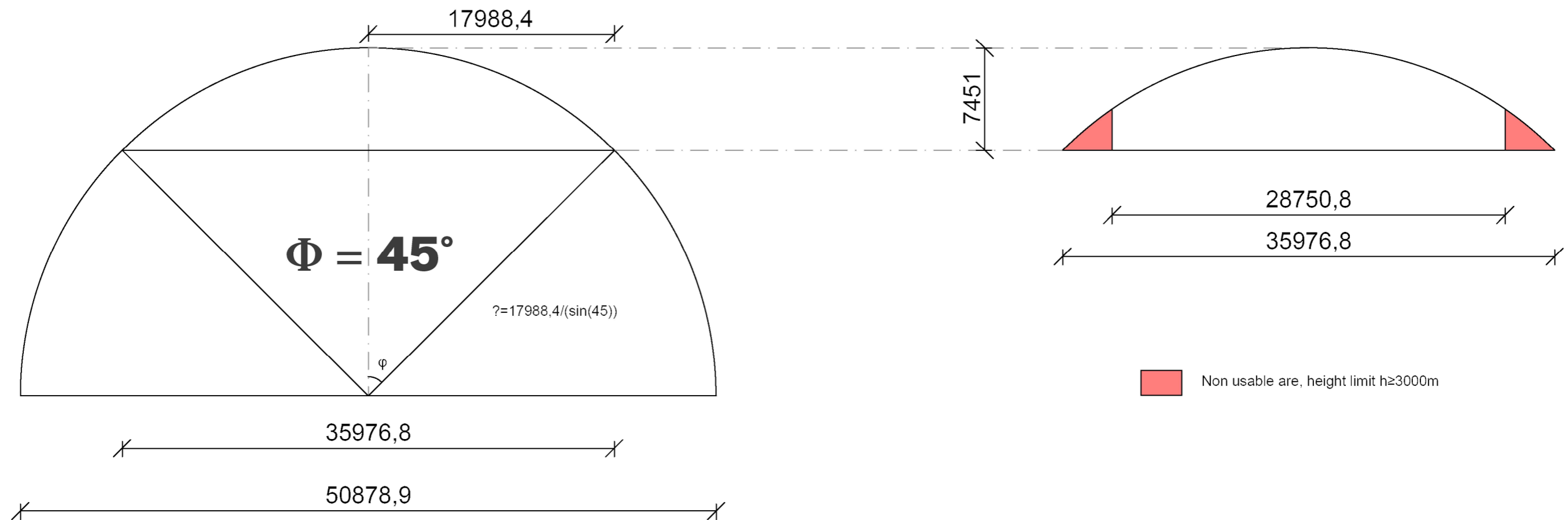

For who?

COMFORT

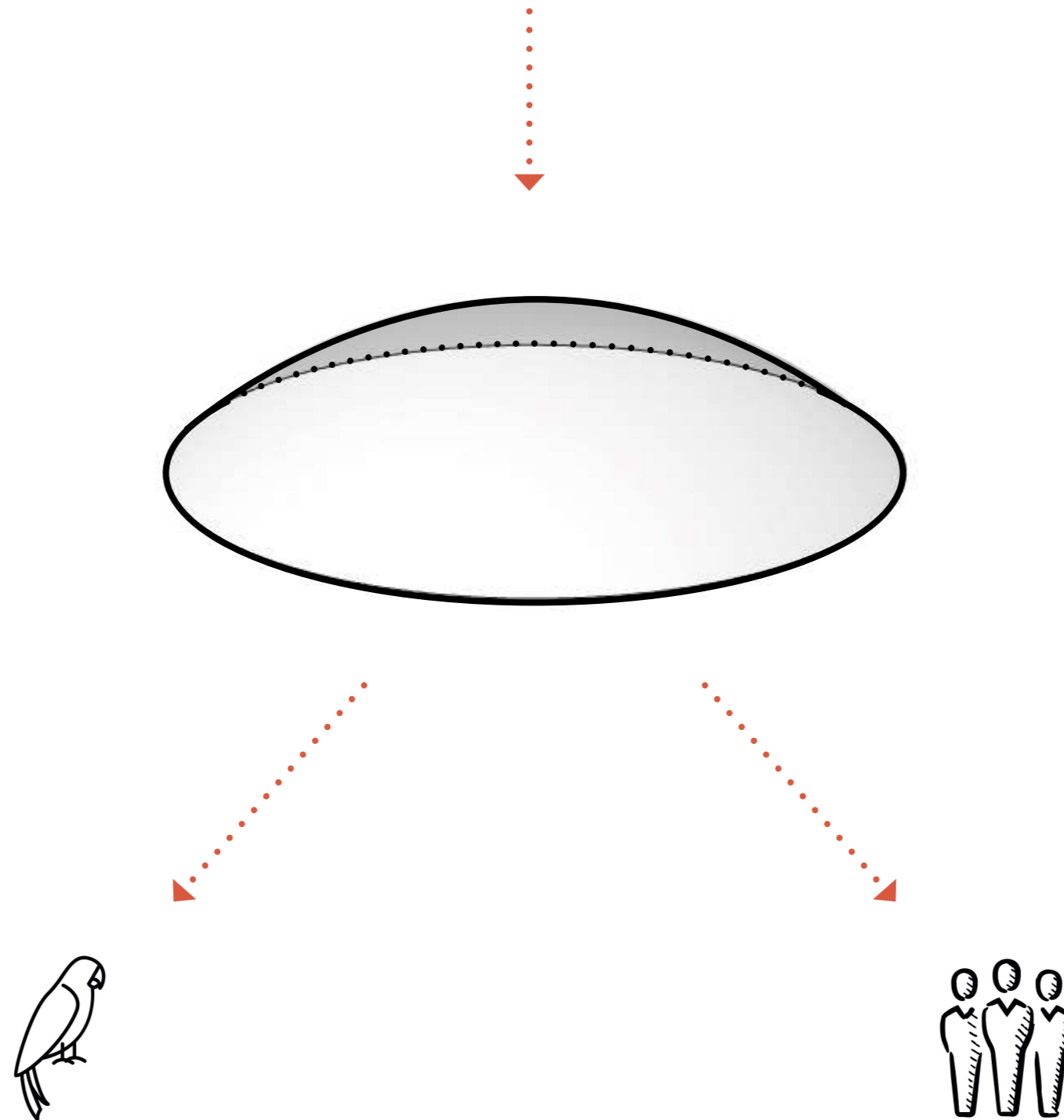

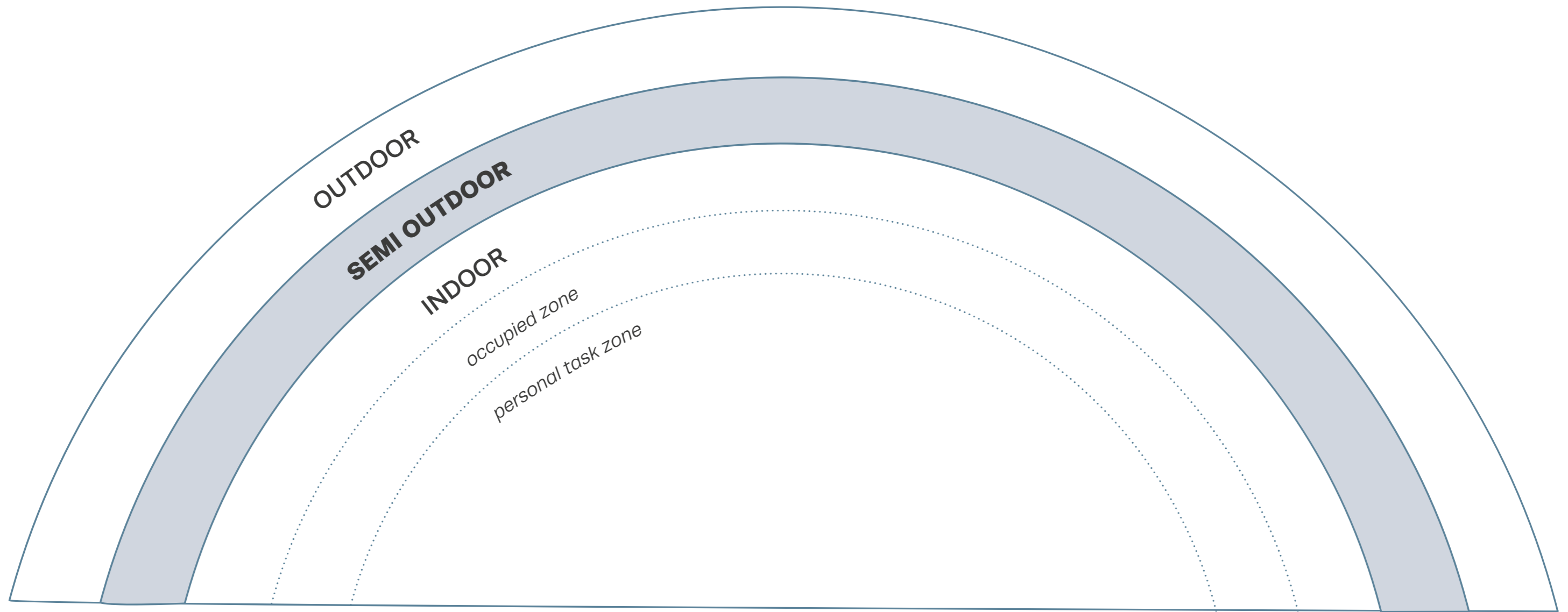





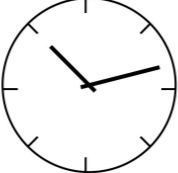

Modified by author based on (Nakano, 2003).

+

$$T_{\text{comf}} = 0,31T_o + 17,8 \quad (\text{ASHREA55})$$

Thermal performance: : Comfort temperature....

			
09:00-19:00	 	30 °C +/- 5	19 °C +/- 5
19:00-09:00		30 °C +/- 5	18 °C +/- 5



PASSIVE SYSTEMS

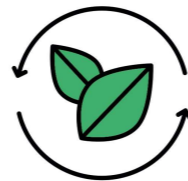

PASSIVE STRATEGIES

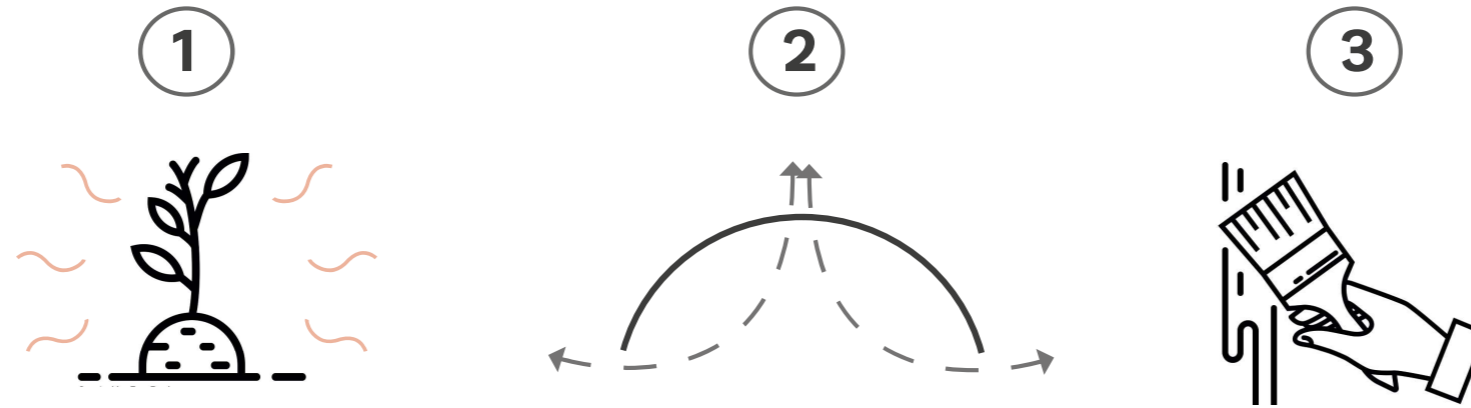

OVERHEATING RISK

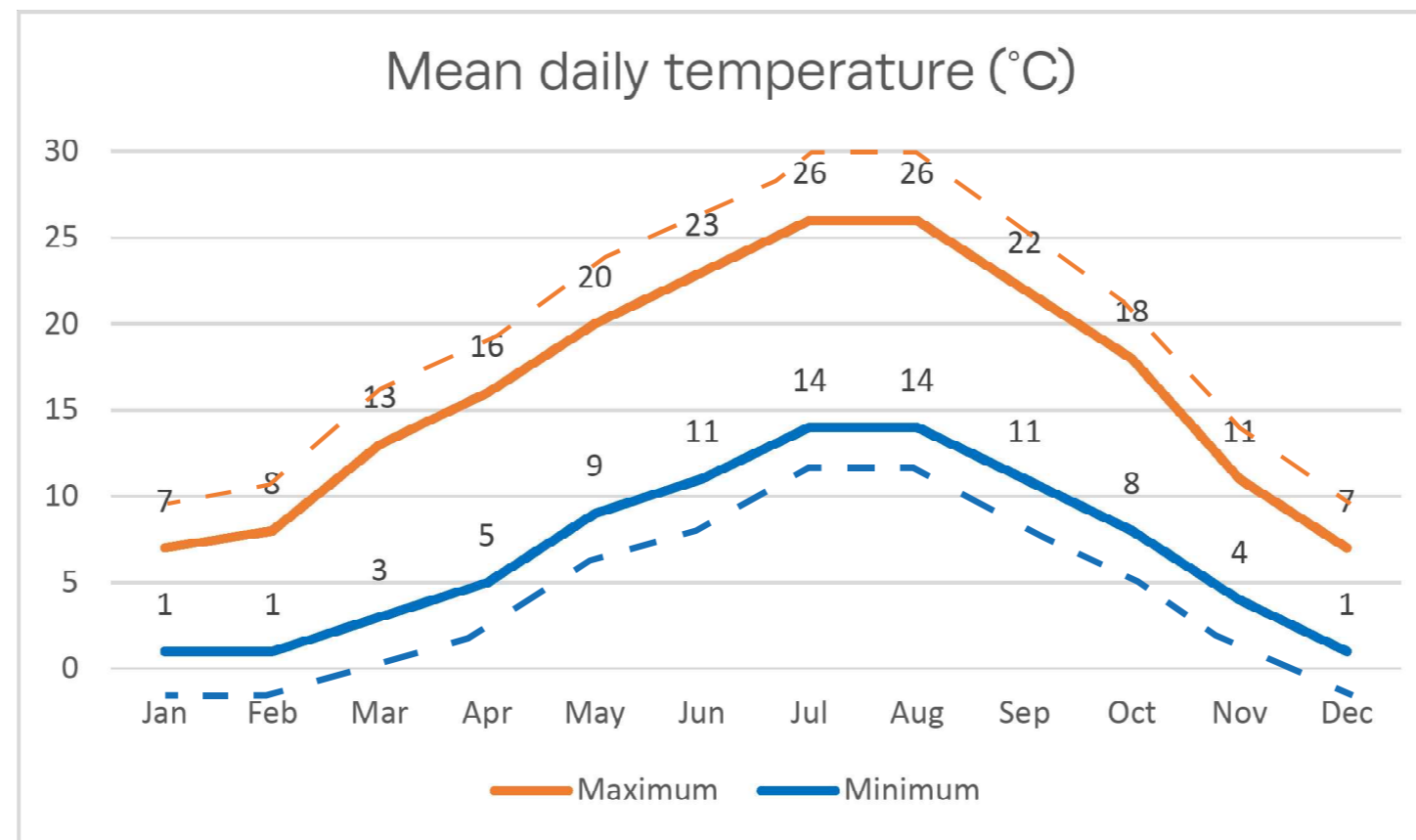

(Meteoblue, 2017)

Thermal performance: Thermal mass...

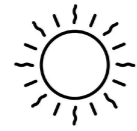

$\nabla P = +7450$

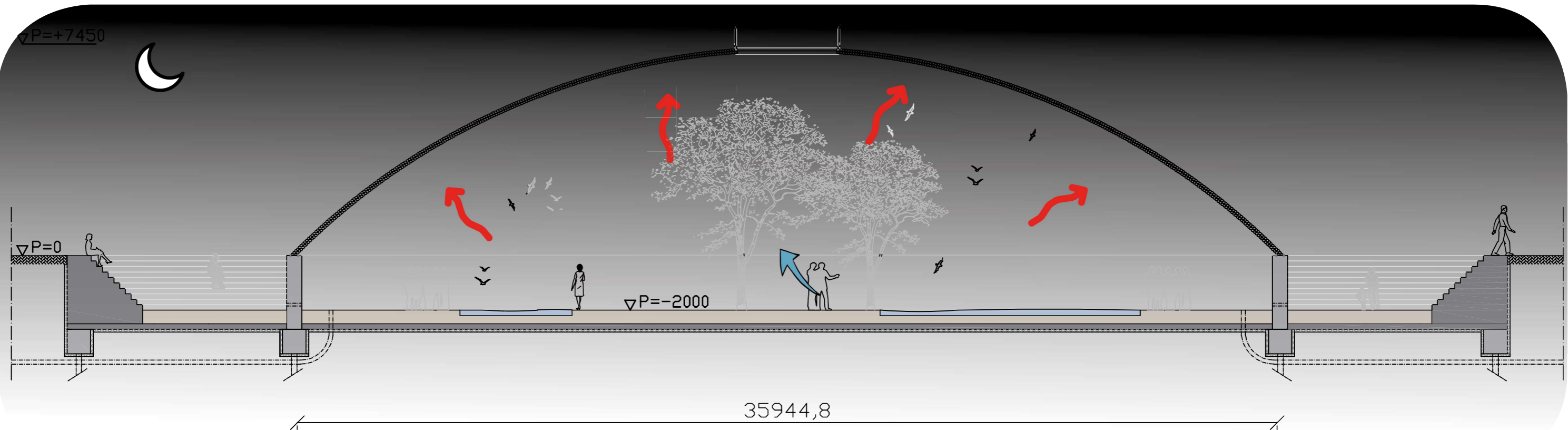
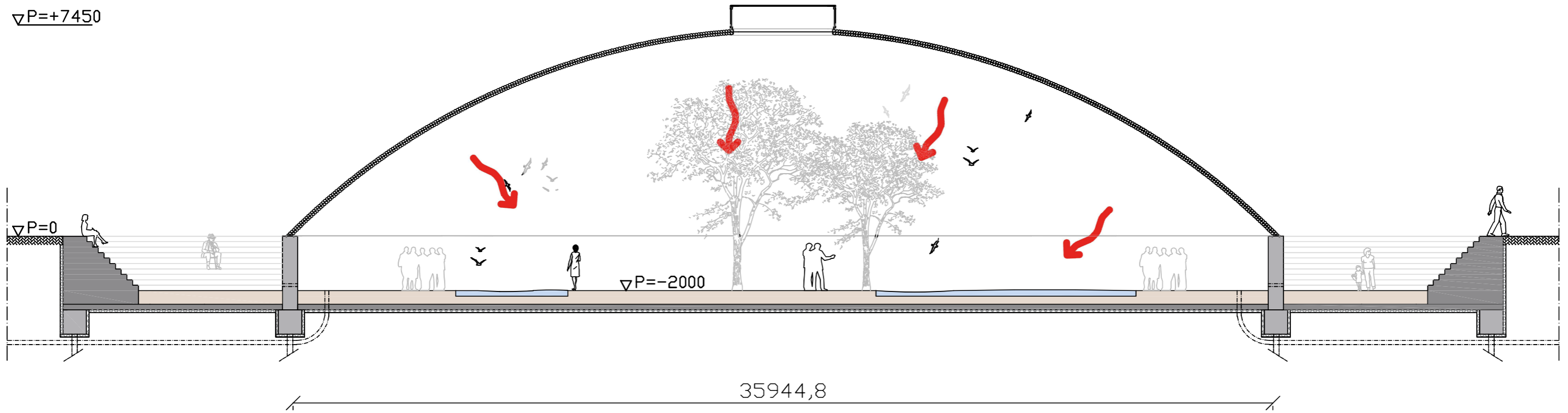

Thermal performance: : Natural ventilation...

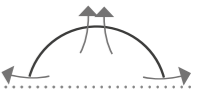

North

South

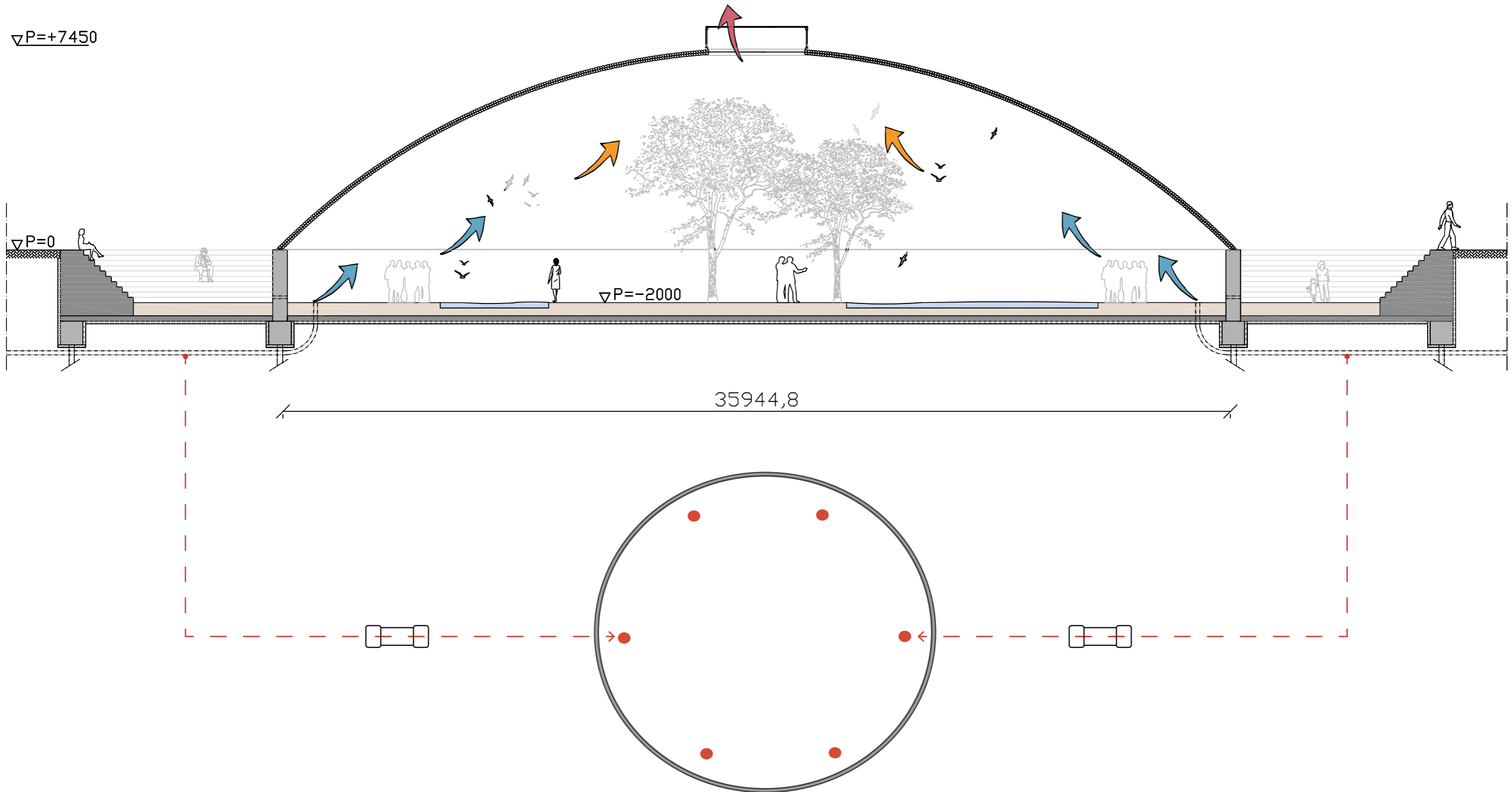

Thermal performance: : *White wash paint...*

SUMMER: 8th Apr. – 30th Sep.

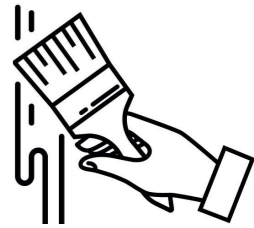
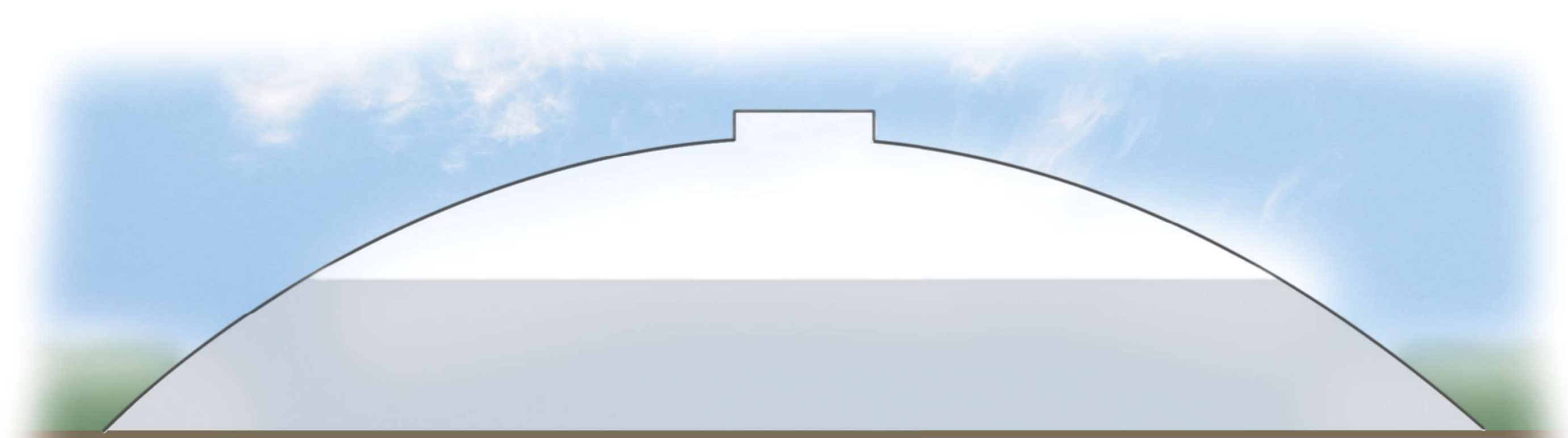

FALL: 1st Oct. – 12th Nov.

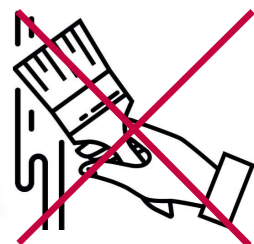

SHALLOW (AVIARY) DOME

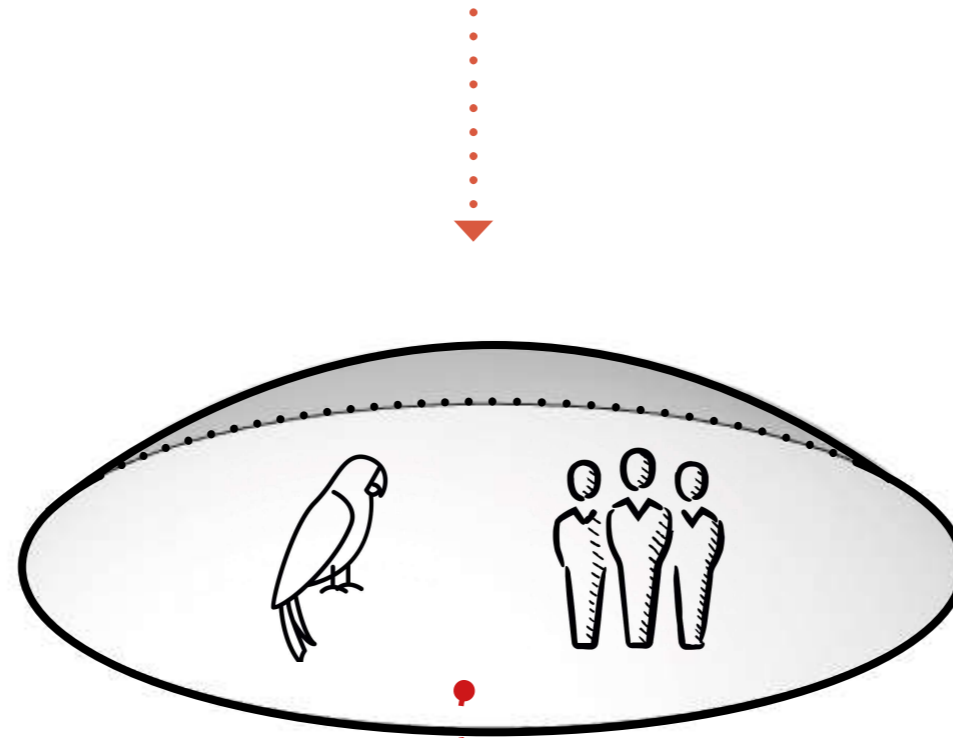

GLASS TYPE?

CAST GLASS



(Oikonomopoulou et al., 2014).



+ HIGH FORM FLEXIBILITY



(source: ifitshipitthere.com).

+ MONOLITHIC STRUCTURE

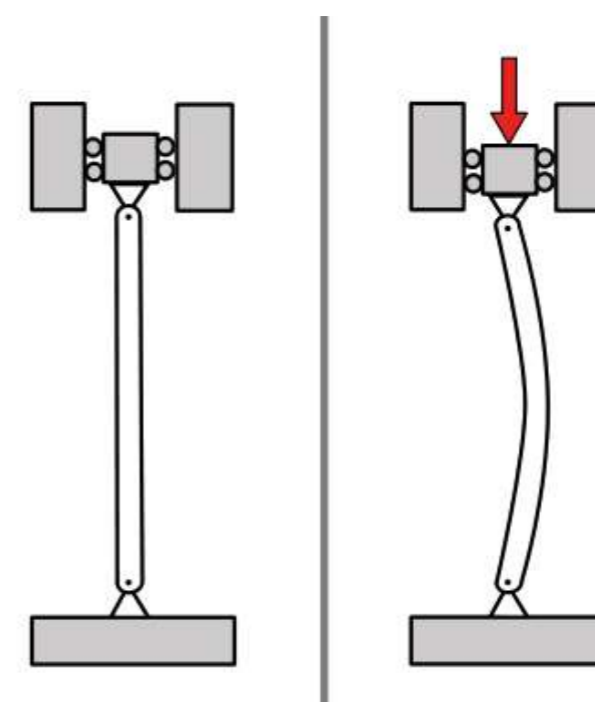

(Schwartz, 2005).

– ANNEALING PHASE

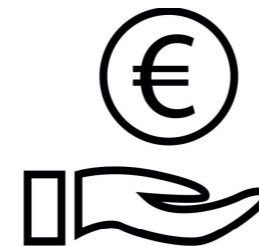
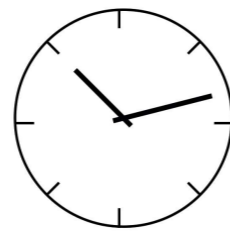

a. Dependent factors

- Temperature difference
- Thermal expansion
- Thickness
- Type of glass

← Heat transfer →

b. parameters

- Shape
- Mass distribution
- Sides exposed to cooling
- Thermal mass & features kiln

SODA-LIME GLASS

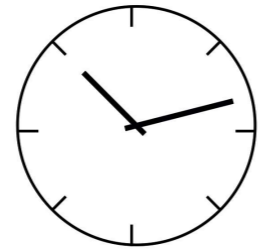

€/KG

KG/m³

~~α~~

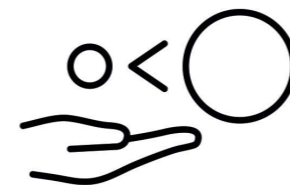

'OPTICAL HOUSE'



(Fujii, nacasa & partners, 2013).

+ Demountable

'CRYSTAL HOUSE'



(Nijse, 2015).

+ Transparent

Demountable & Transparent

INTERLOCKING SYSTEMS

(Fuji, nacasa & partners, 2013)

(Nijse, 2015)

Interlocking systems: *Examples...*

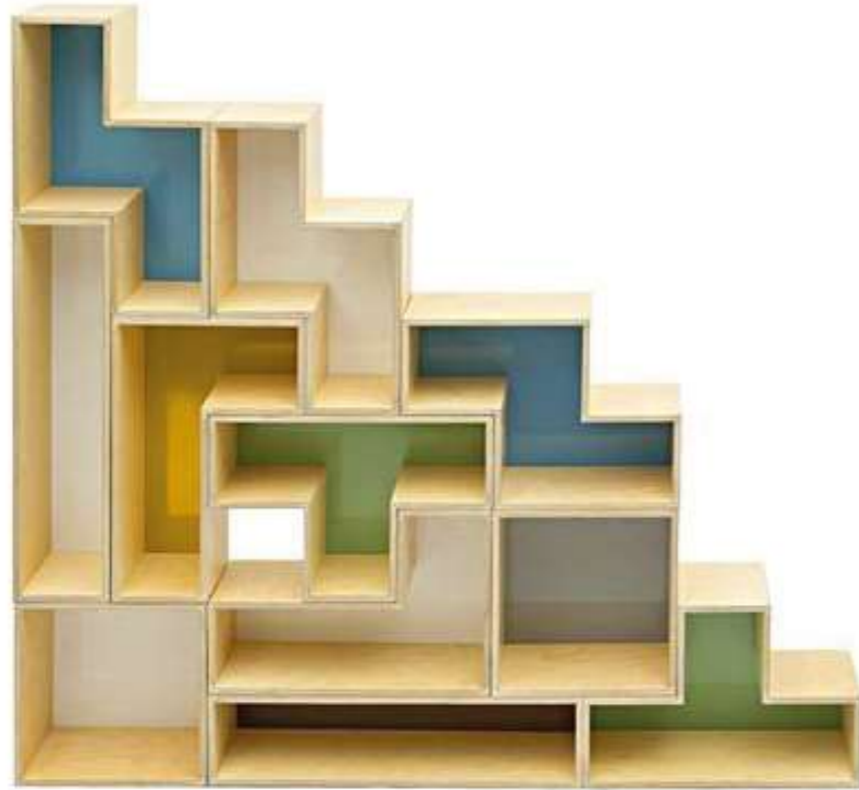

(source: www.fantv.nl).



(Macleod, 2014).

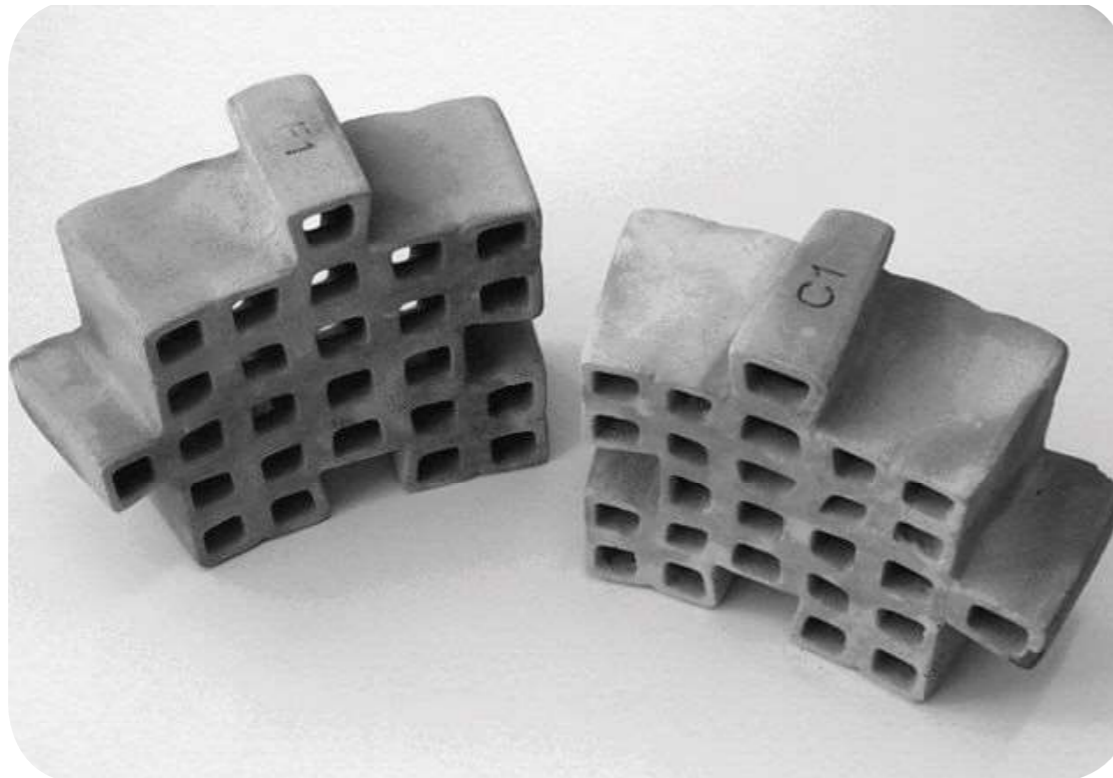

(source: Archiweb, 2014).



(Roblin, 2011).

INTERLOCKING SYSTEM

INTERLAYER

INTERLOCK

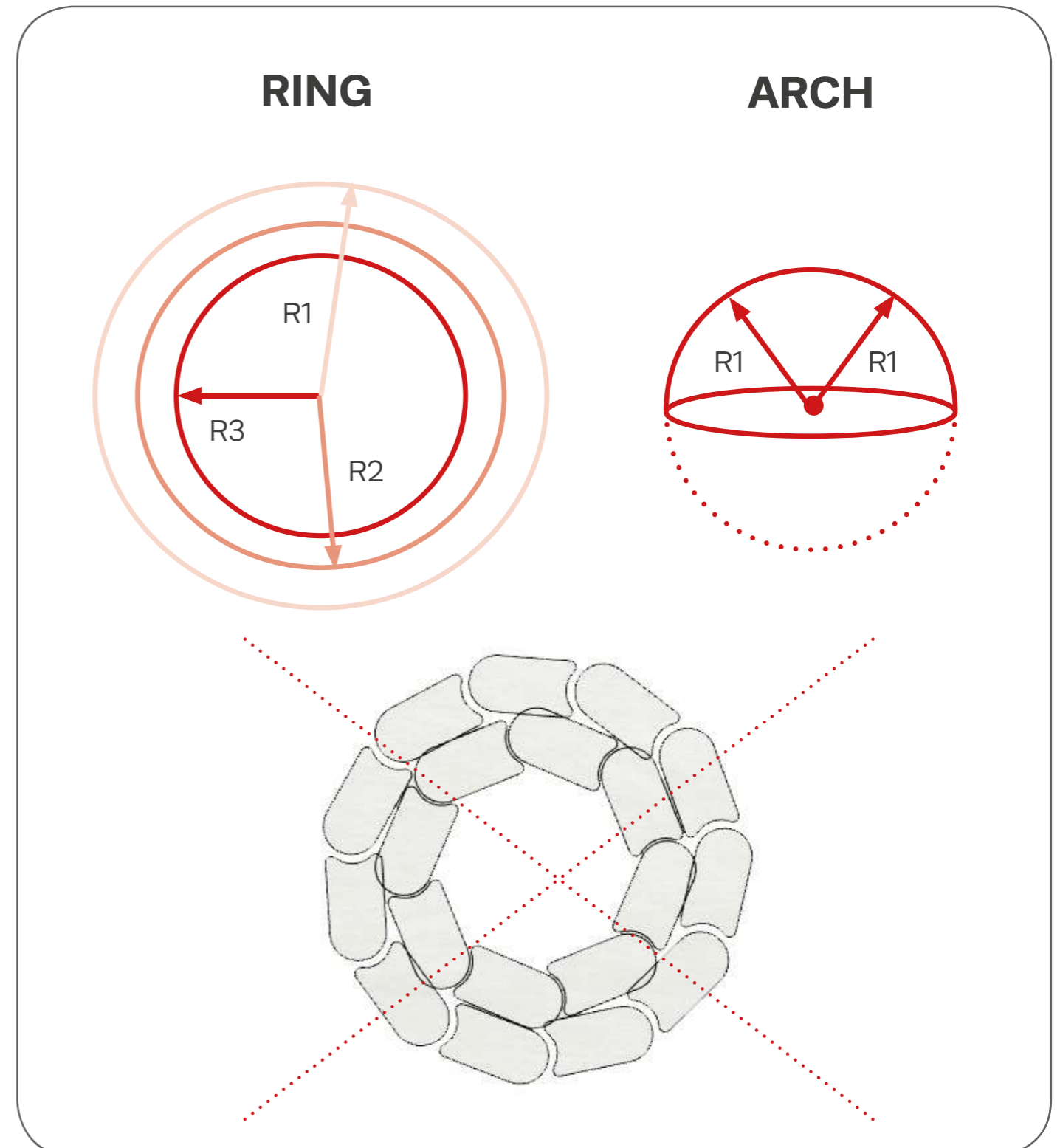
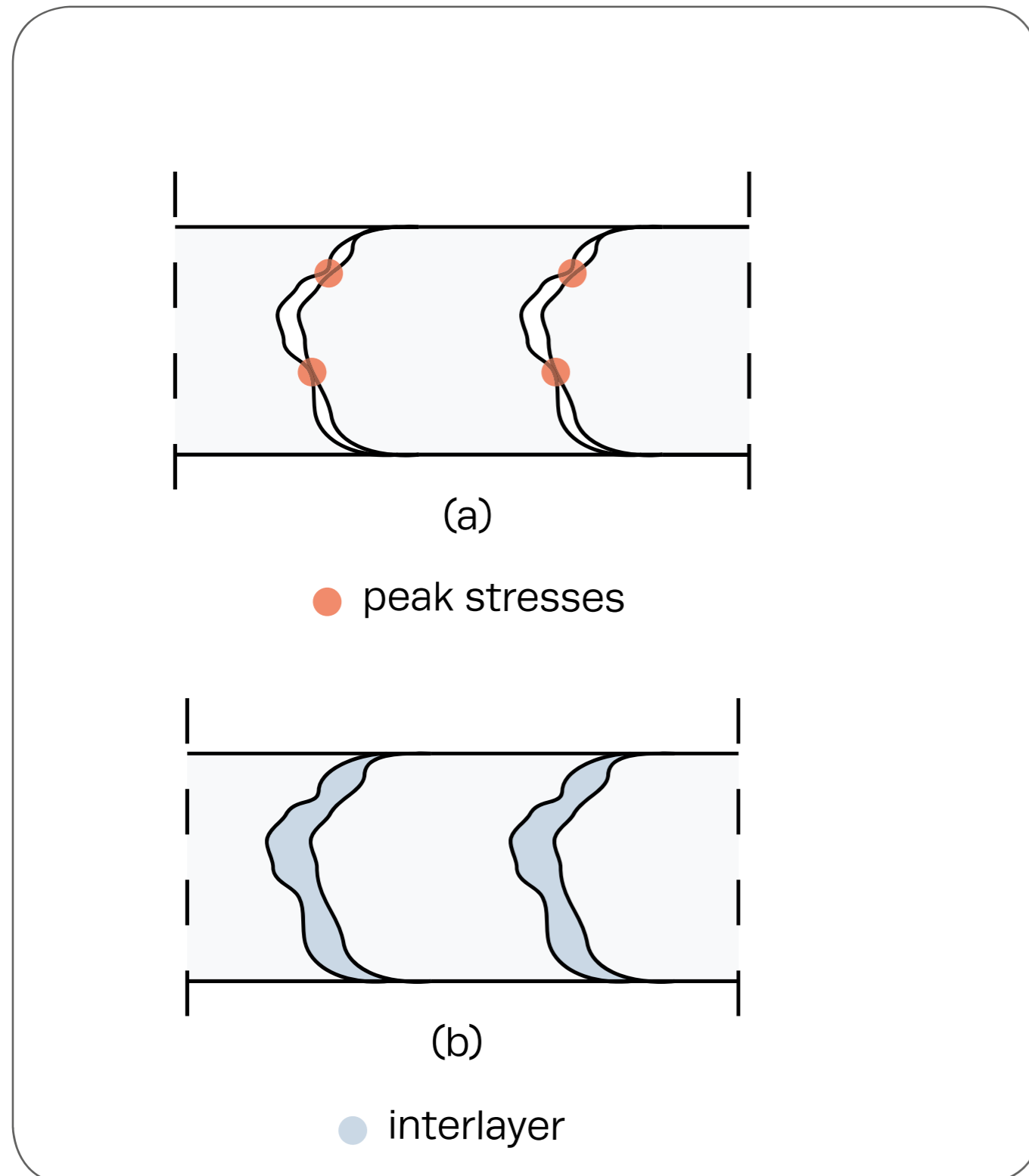

OMNIDIRECTIONAL



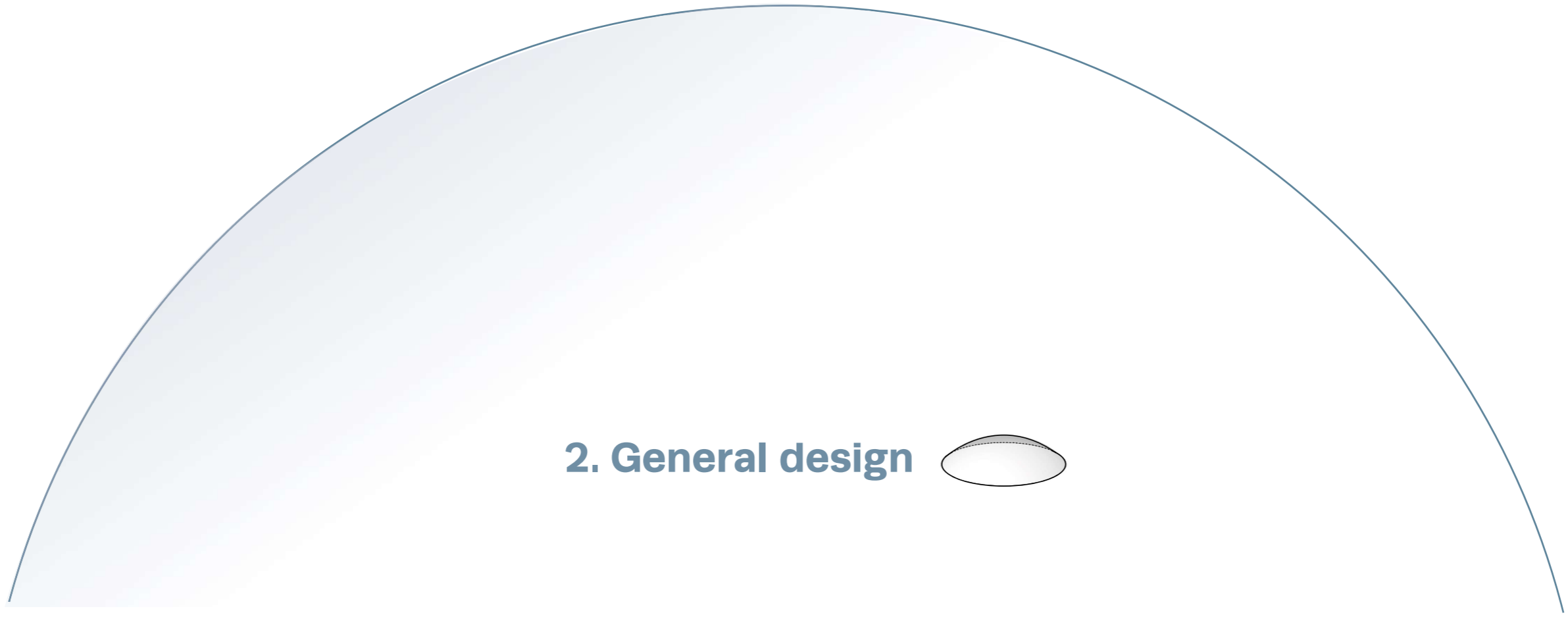

2. General design



Floor plan | Cross section | Oculus

General design: Floor plan....

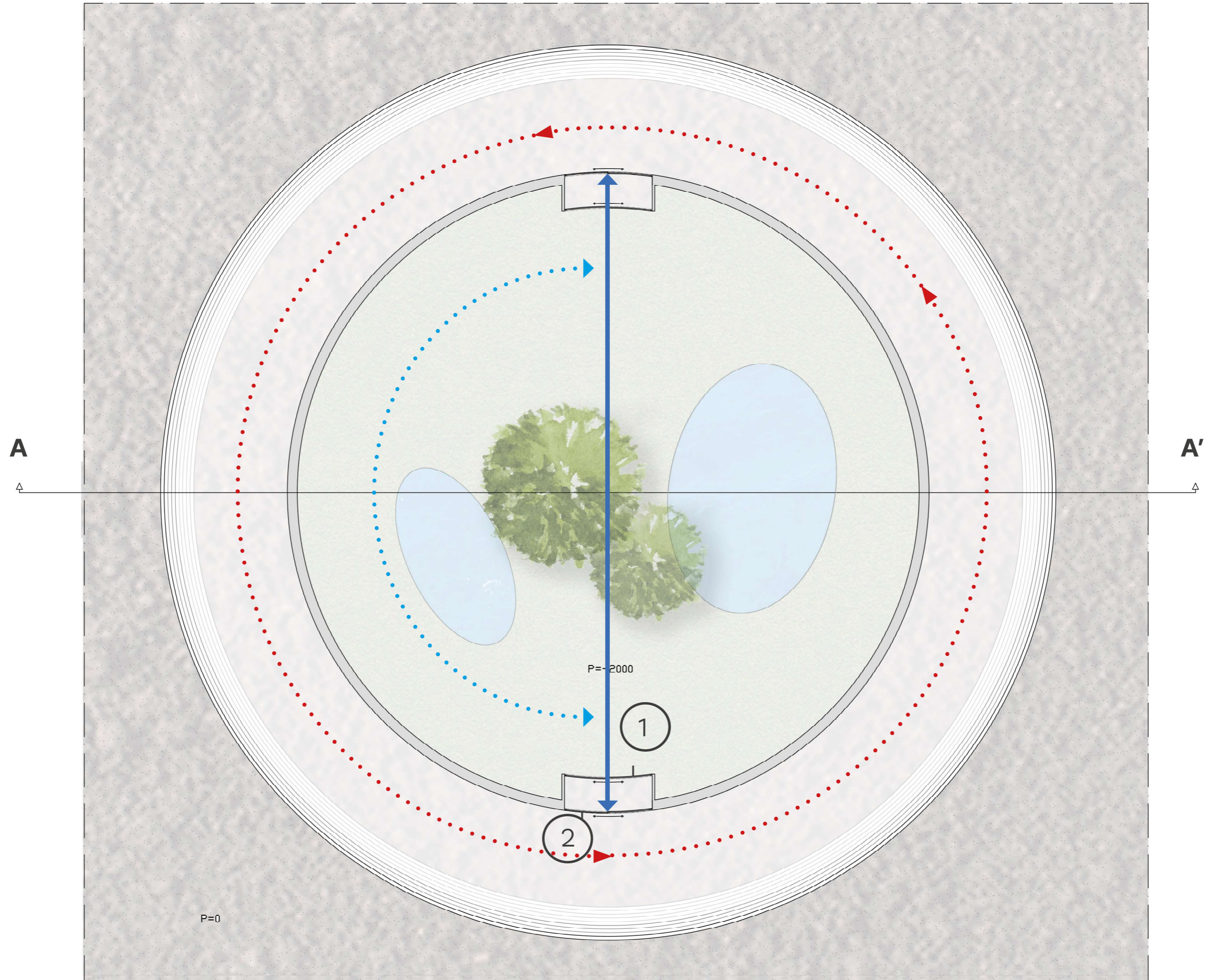

General design: Cross section A-A',...

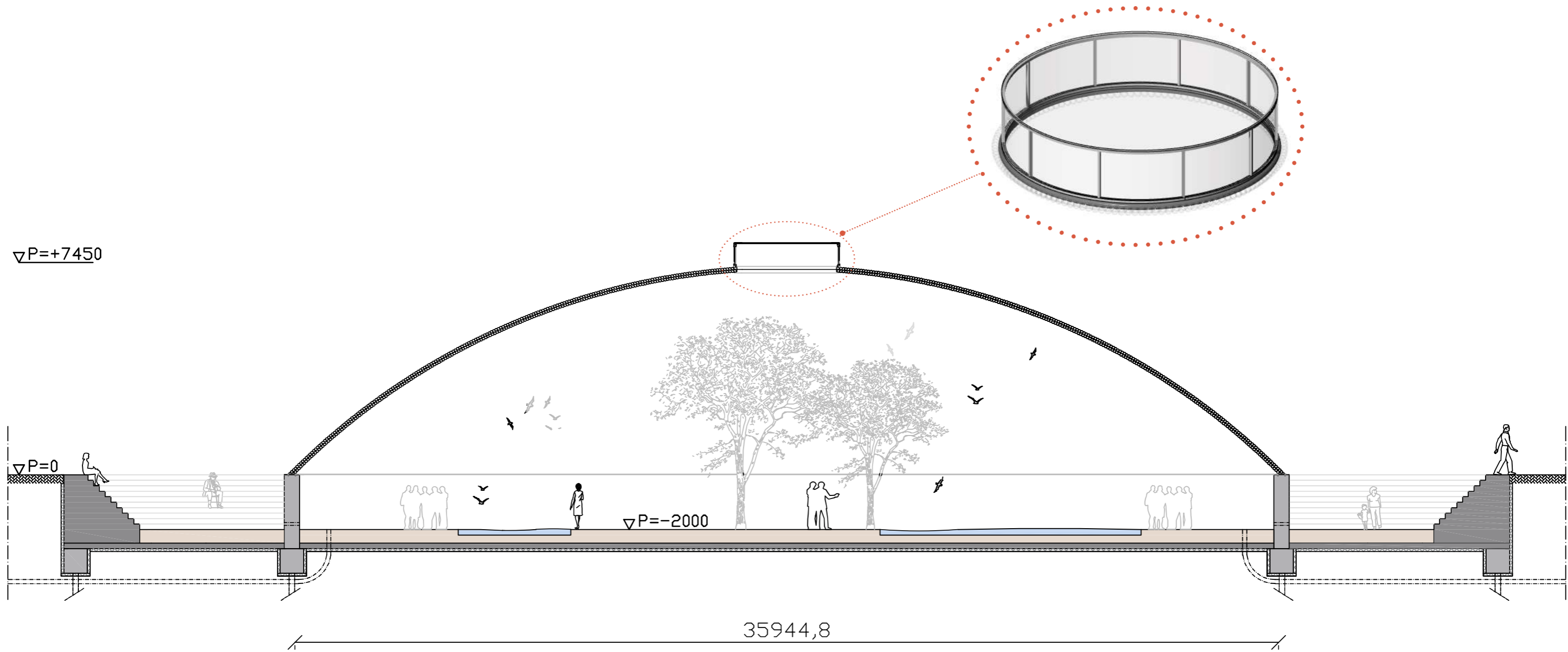

General design: *Oculus*...

2 panels laminated
of safety glass

Bird-net

Aluminium window frame

Steel compression ring

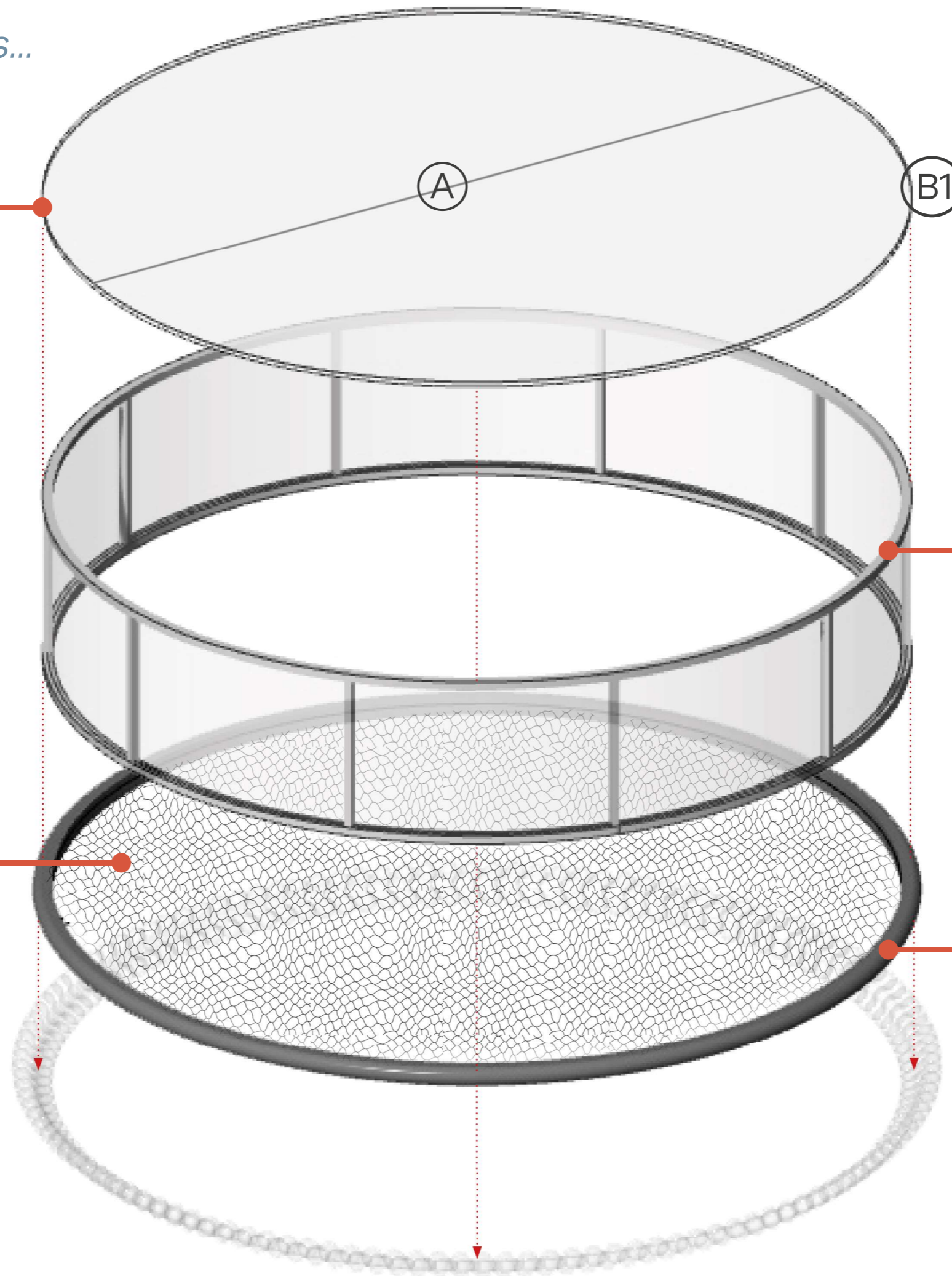

General design: Oculus detail A ...

MAX: 3.2X16M

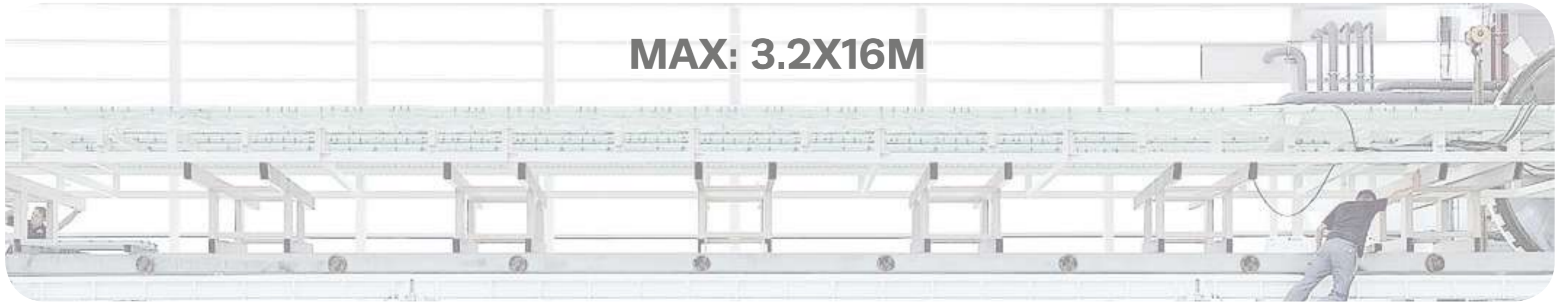

(Sedak Company, 2018).

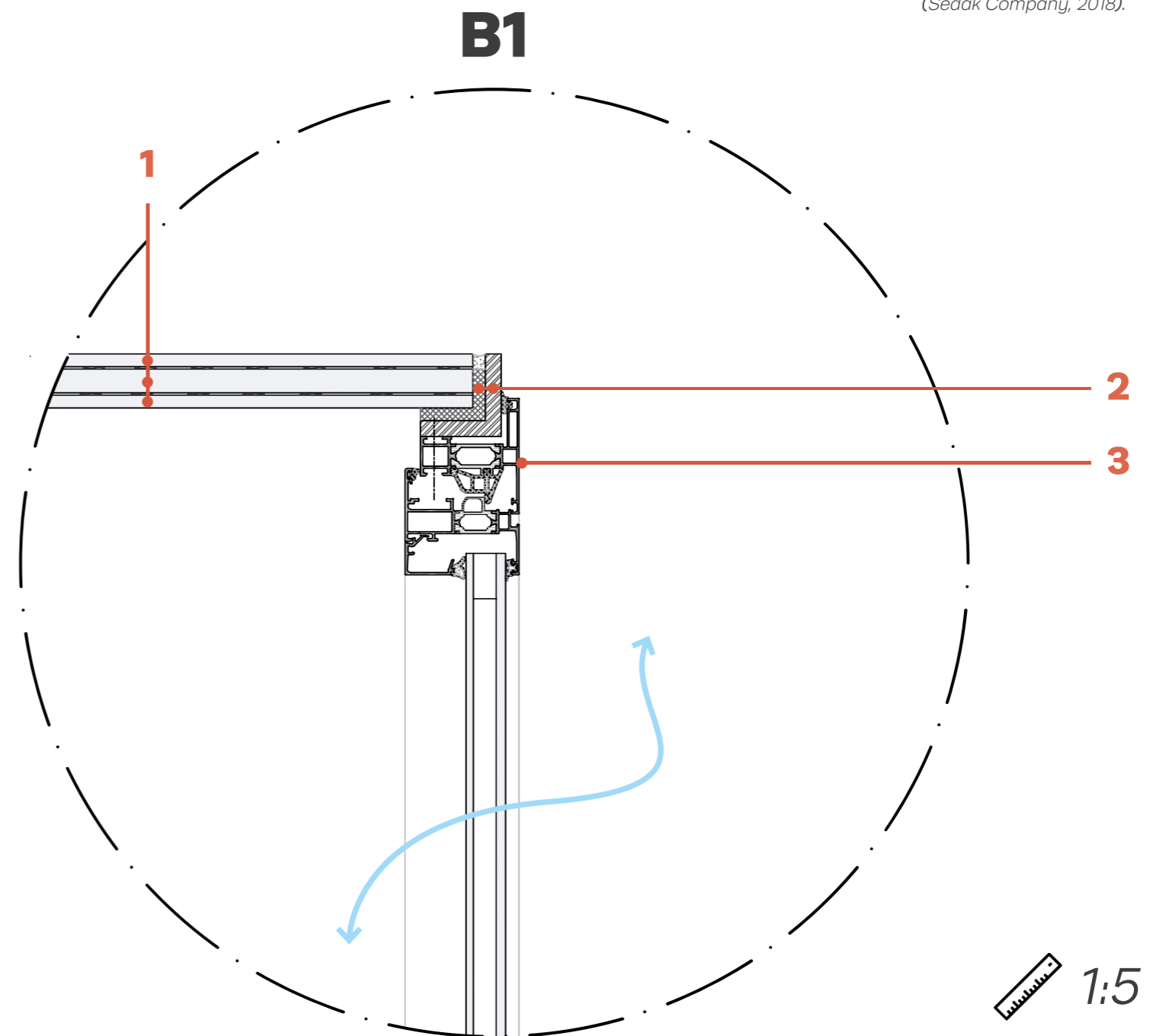
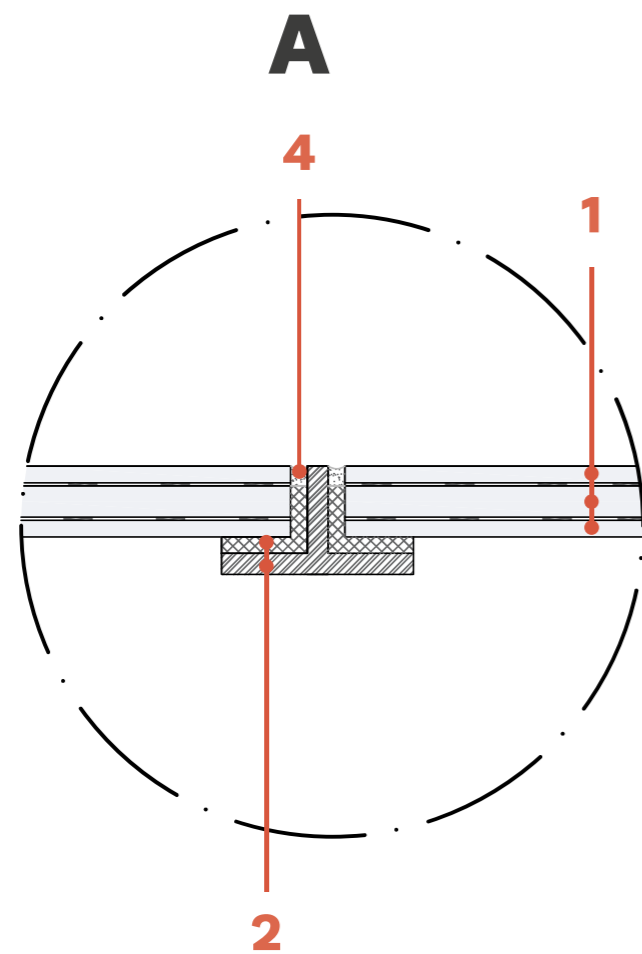

1:5

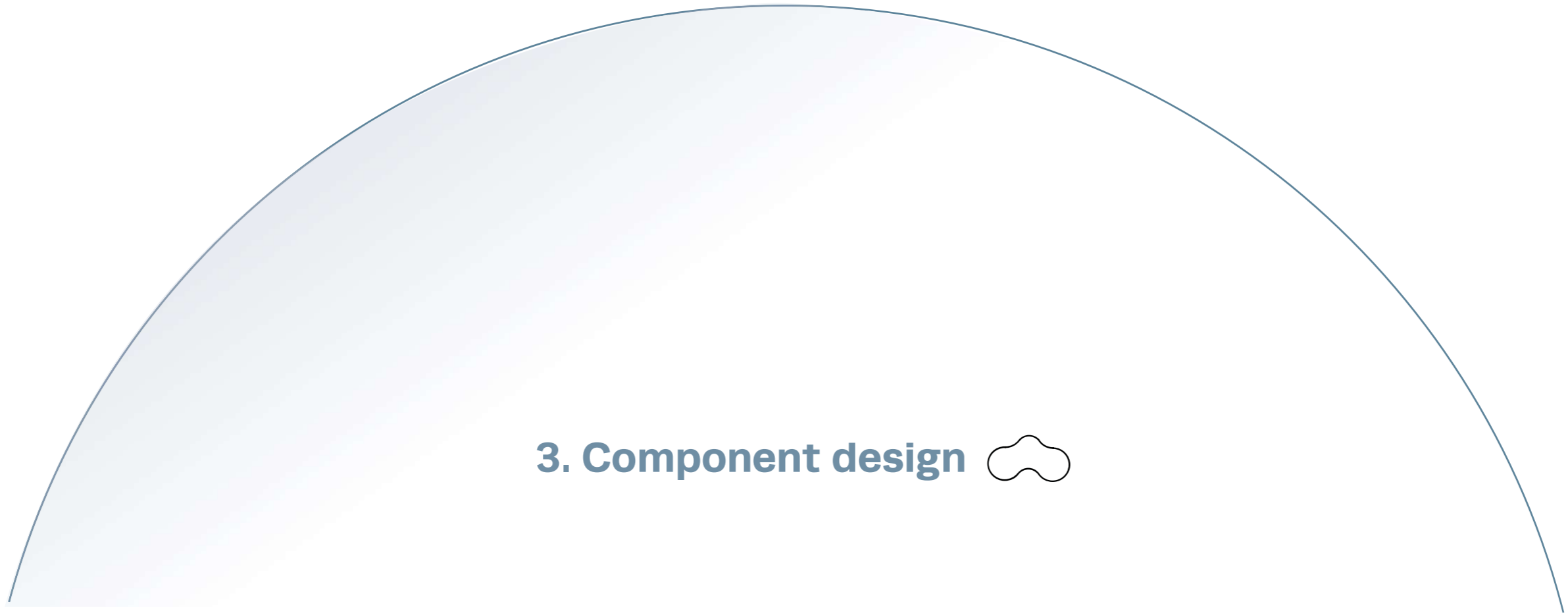

3. Component design

Design principles | Previous attempts | Final component | Interlayer | Feasibility

Design principles: Existing cast glass interlocking systems....



(Oikonomopoulou, 2017).



(Akerboom, 2016).



(Smits, 2015).

Design principles: General principles....

1. Mass <10kg

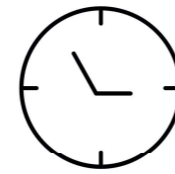

Reduce annealing time

2. One component

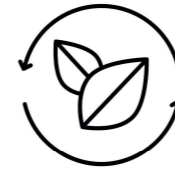

Minimize different steel molds

3. Round edges

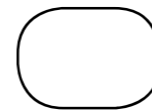

Prevent peak stresses

4. Homogeneous mass distribution

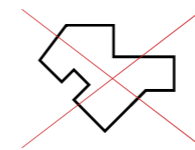

Ensure homogeneous shrinkage

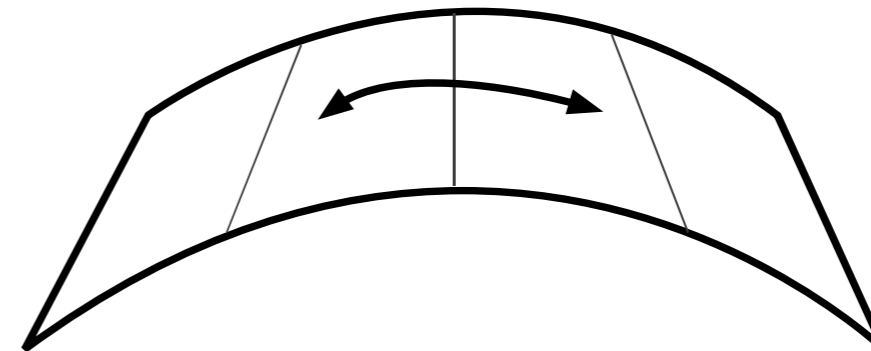
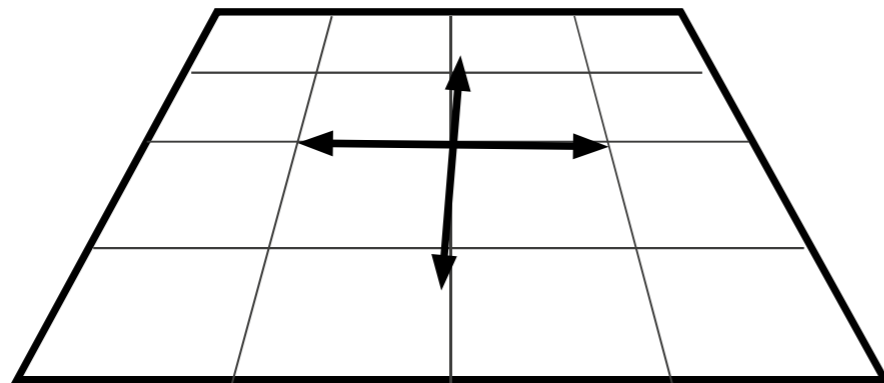

Design principles: Dome principle....

1. Mass <10kg>		<i>Reduce annealing time</i>
2. One component>		<i>Minimize different steel molds</i>
3. Round edges>		<i>Prevent peak stresses</i>
4. Homogeneous mass distribution>		<i>Ensure homogeneous shrinkage</i>
5. Spherical configuration>		<i>Design omnidirectional</i>
6. Small elements>		<i>Reduce rotation angle</i>

DOUBLE CURVED

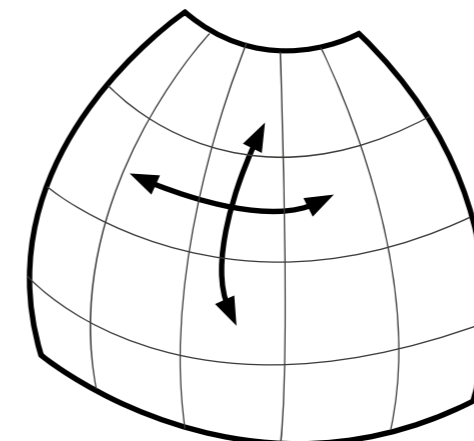

The background of the image is a sheet of lined paper covered with numerous hand-drawn sketches in pencil or light ink. The sketches are primarily composed of circles and spheres, often arranged in clusters or groups. Some of these clusters are labeled with letters: 'A', 'B', 'C', and 'D'. For example, there are clusters of three spheres labeled 'A', 'B', and 'C'; a cluster of four spheres labeled 'A', 'B', 'C', and 'D'; and a cluster of six spheres labeled 'A', 'A', 'A', 'B', 'B', and 'B'. There are also sketches of pairs of spheres, single spheres, and some more complex, multi-layered or overlapping sphere arrangements. Some sketches include lines connecting the spheres, possibly representing bonds or interactions. The overall style is that of a brainstorming or conceptual drawing session.

SPHERE BASED DESIGN

Previous attempts

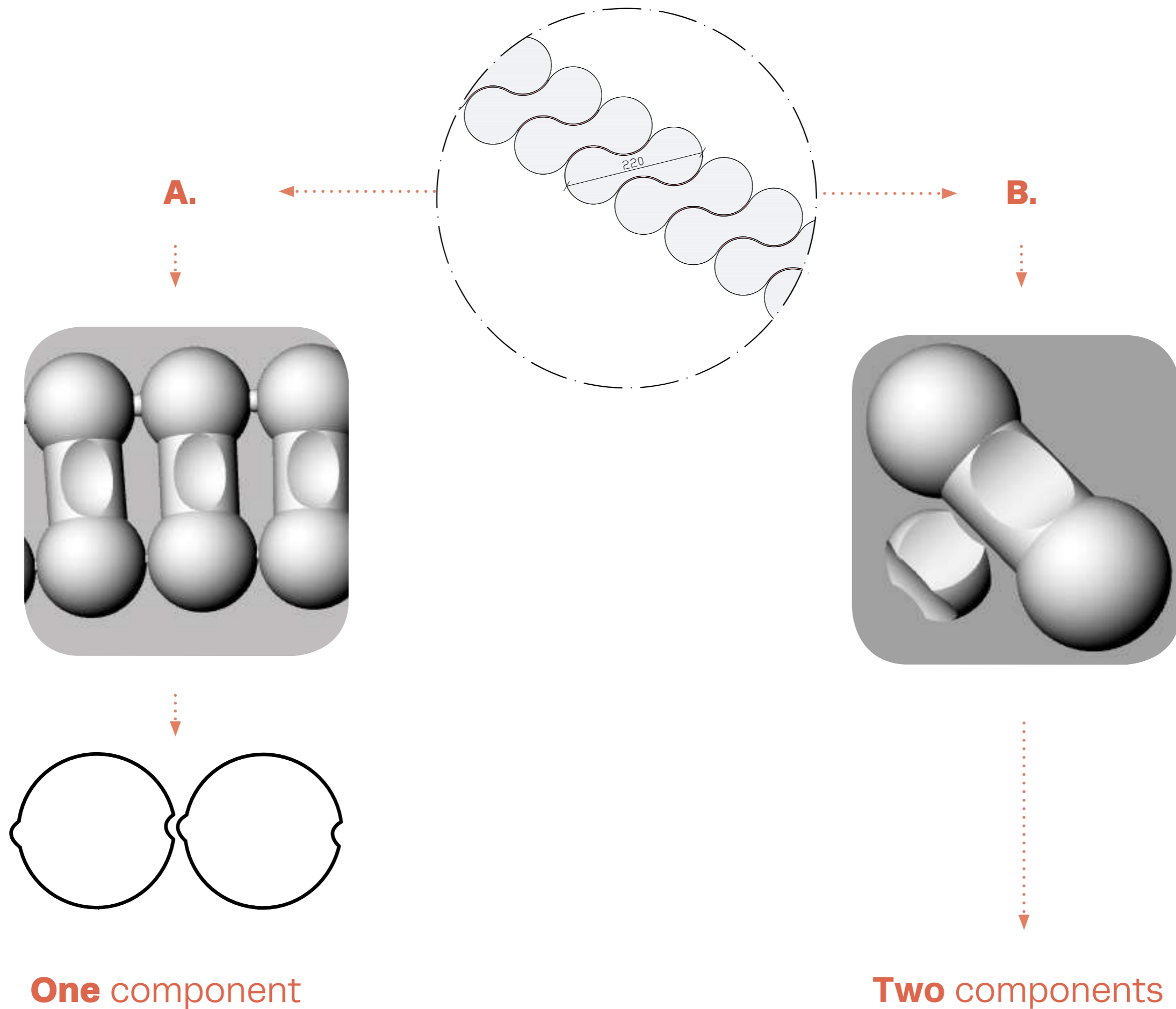

RING

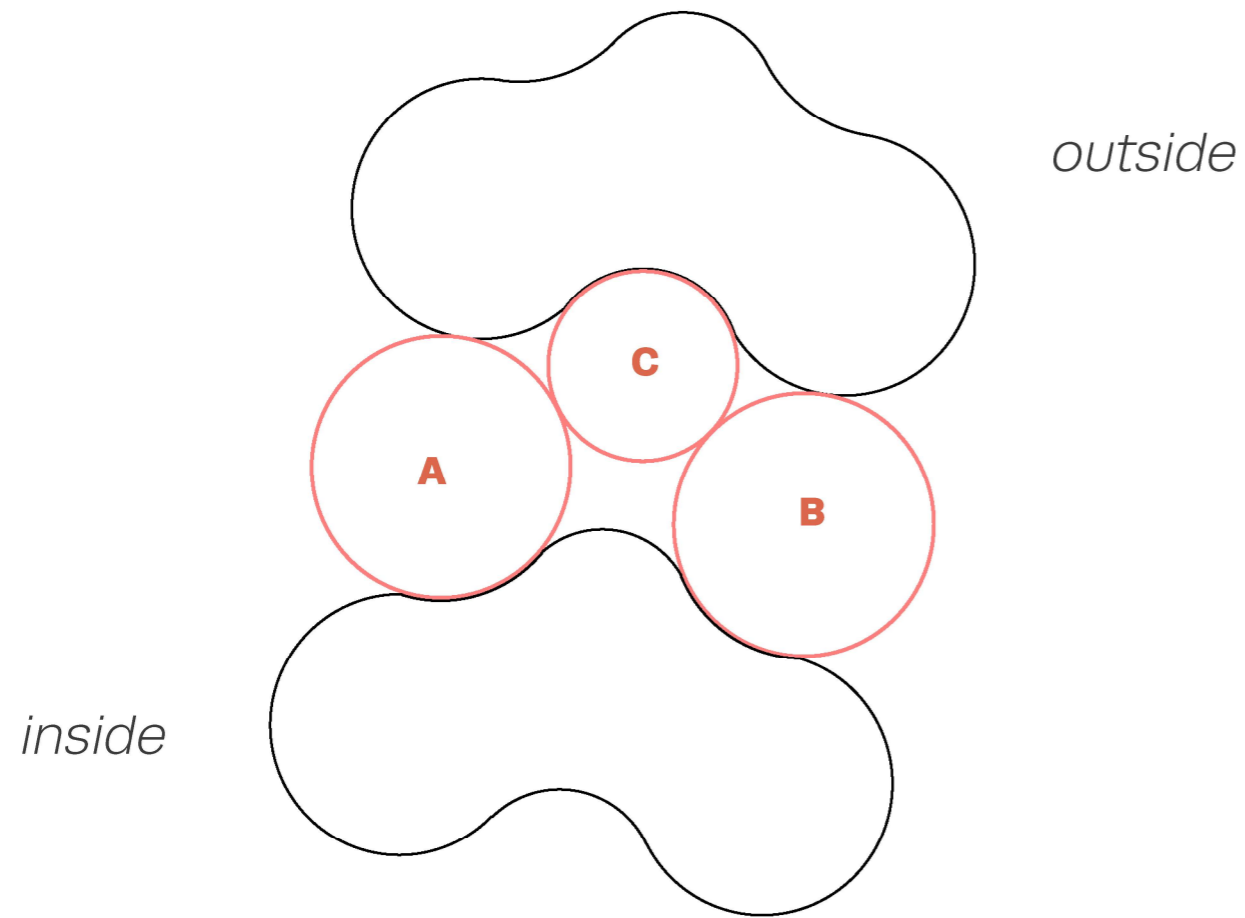

ARCH

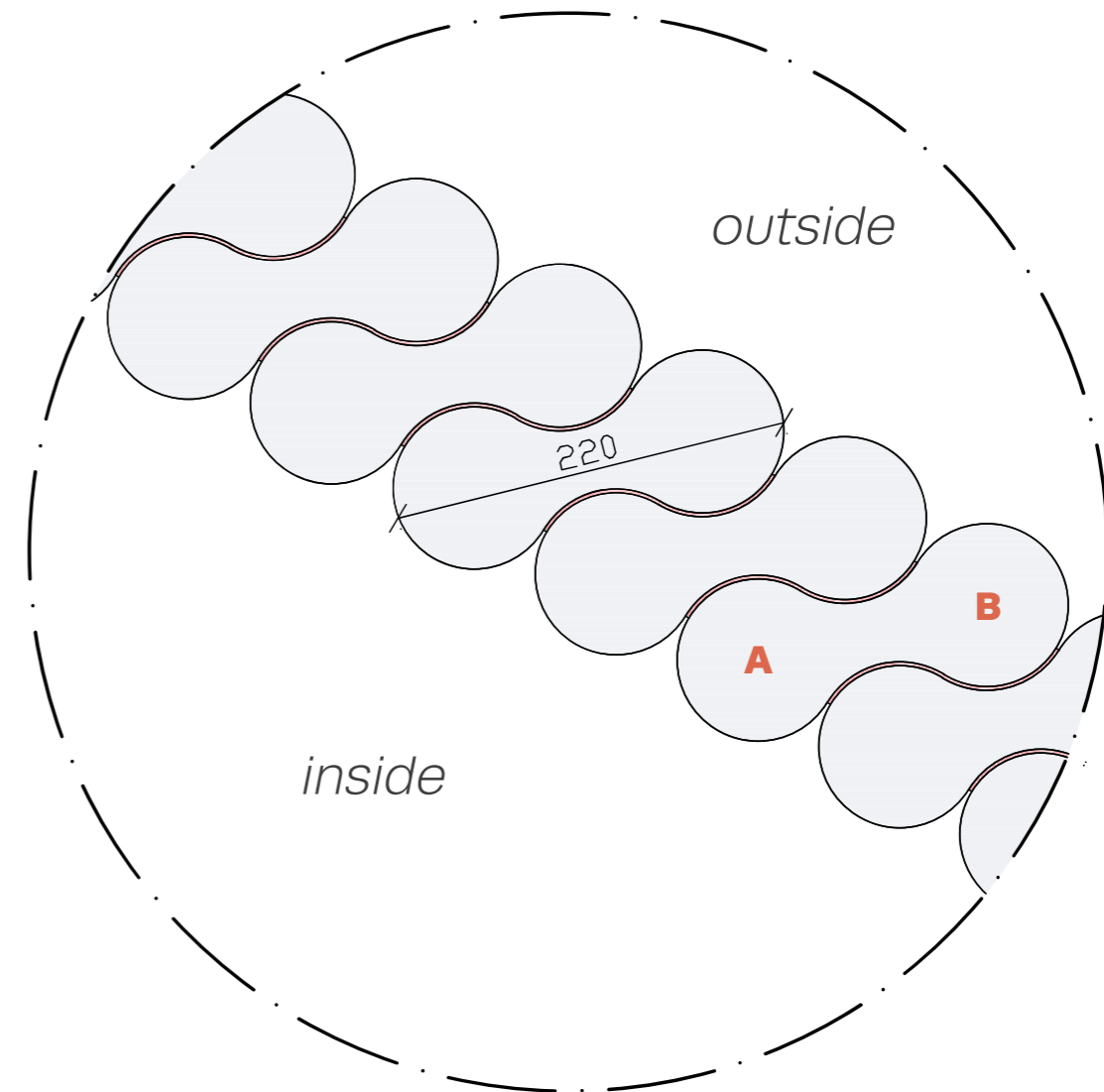

Sphere	Radius (mm)	Diameter (mm)
A	45,025	92,05
B	46,192	92,19
C	33,460	66,92

Final component: Amount of components...

#Rings

#Components

197

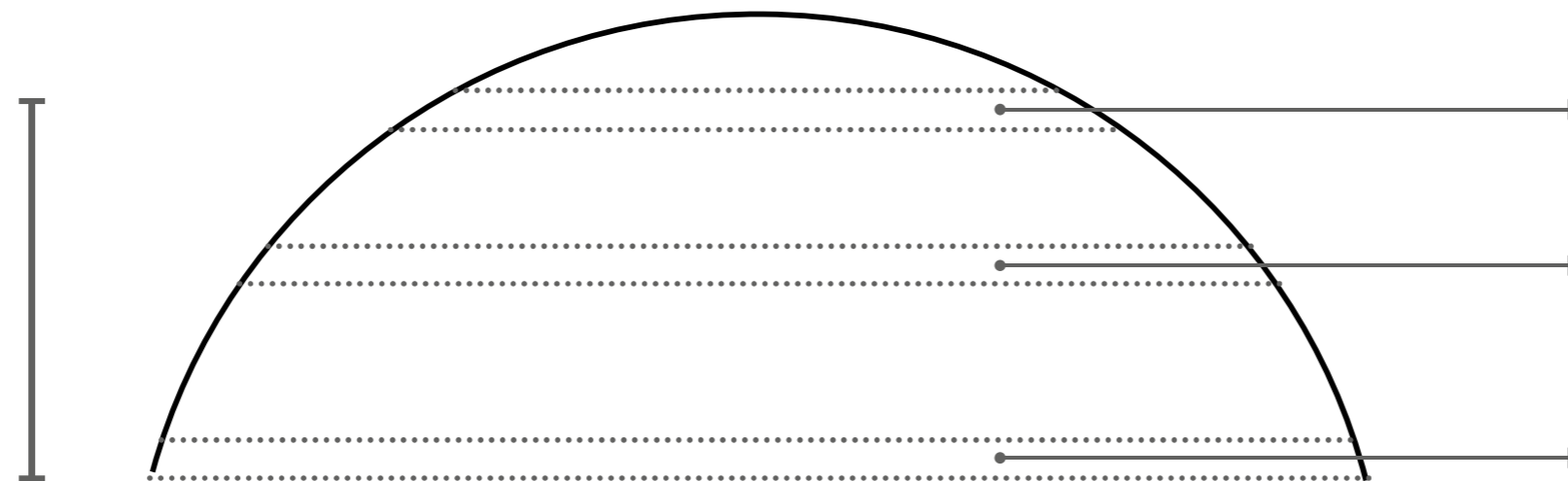

128

733

1225

Total : 139132

Final component: *Final shape & inspiration*

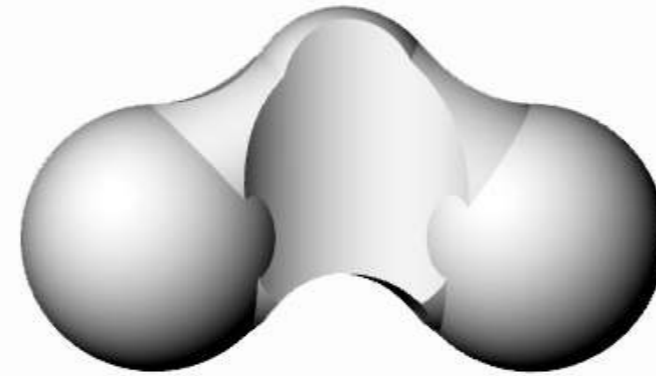
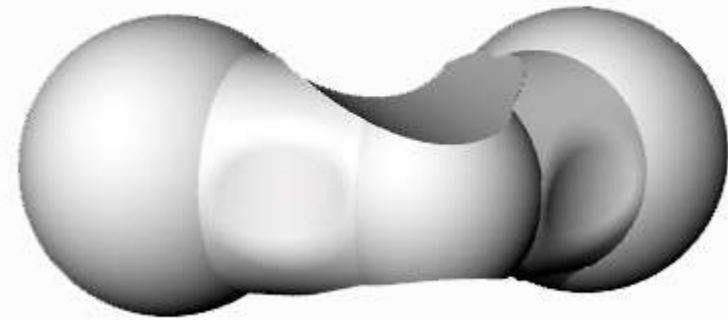

2,5 kg < 10 kg

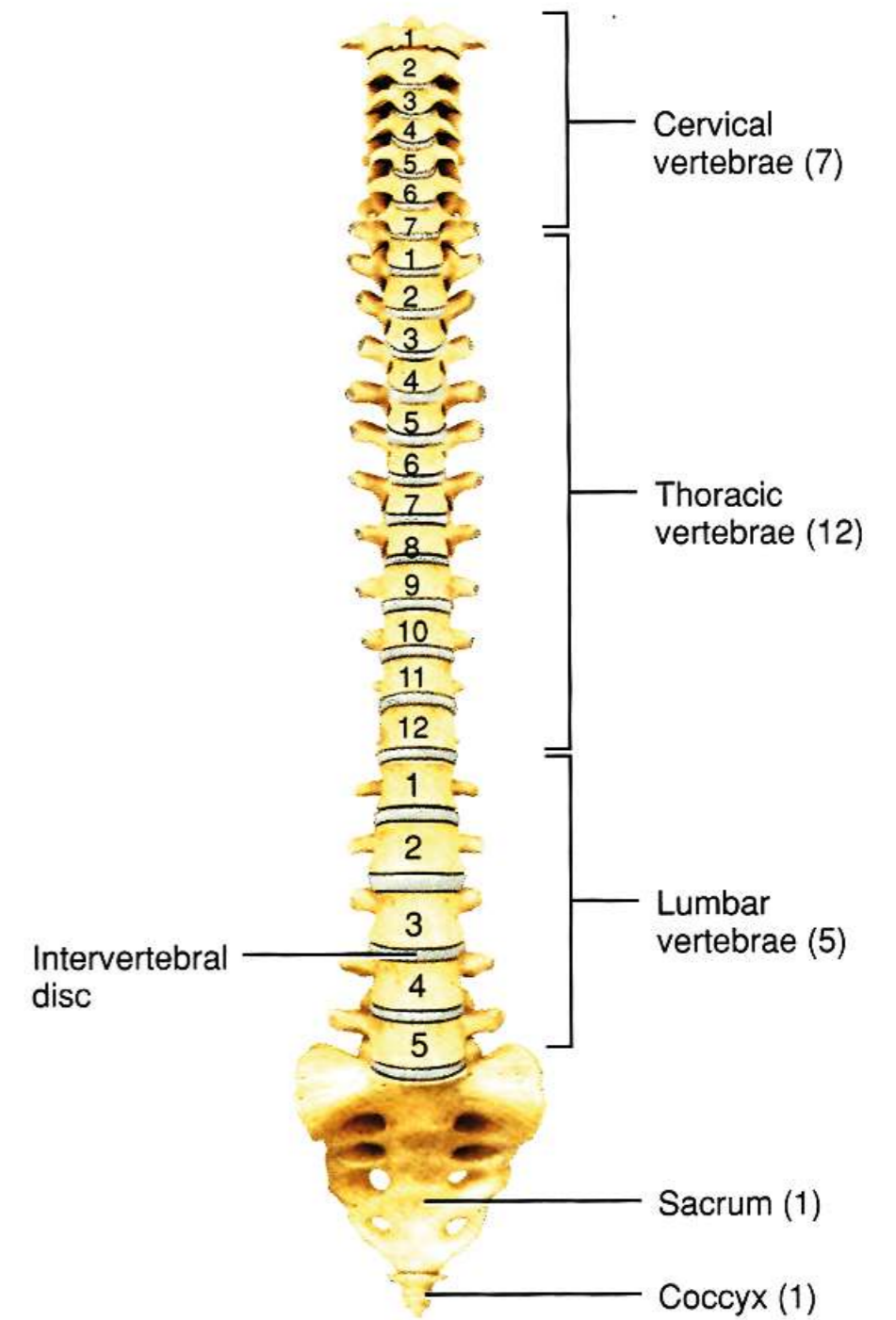
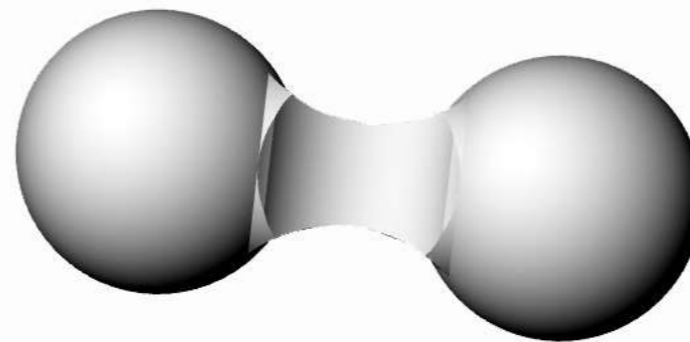
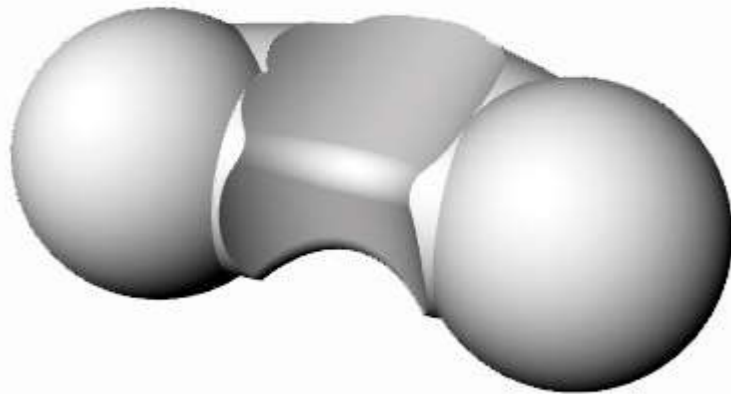

(a) Anterior view showing regions of the vertebral column

(Tortora and Derrickson, 2009).

Steel precision

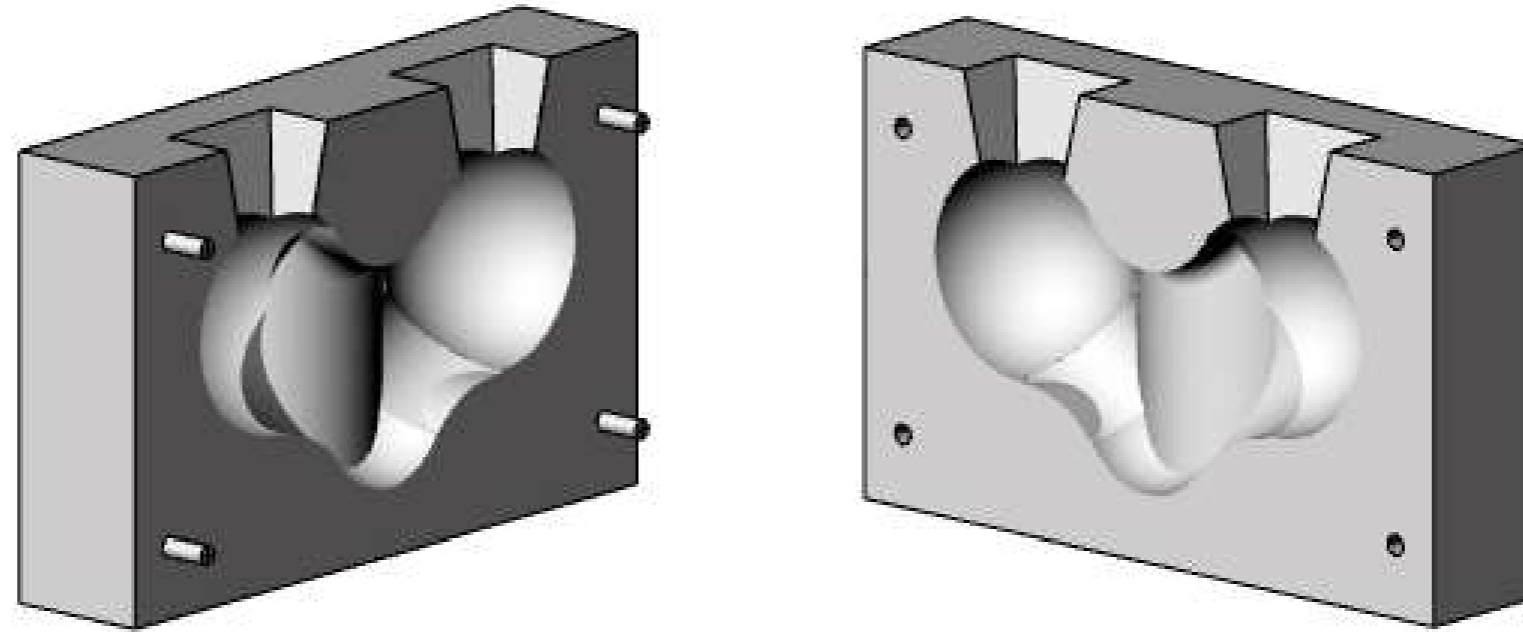

Disposable

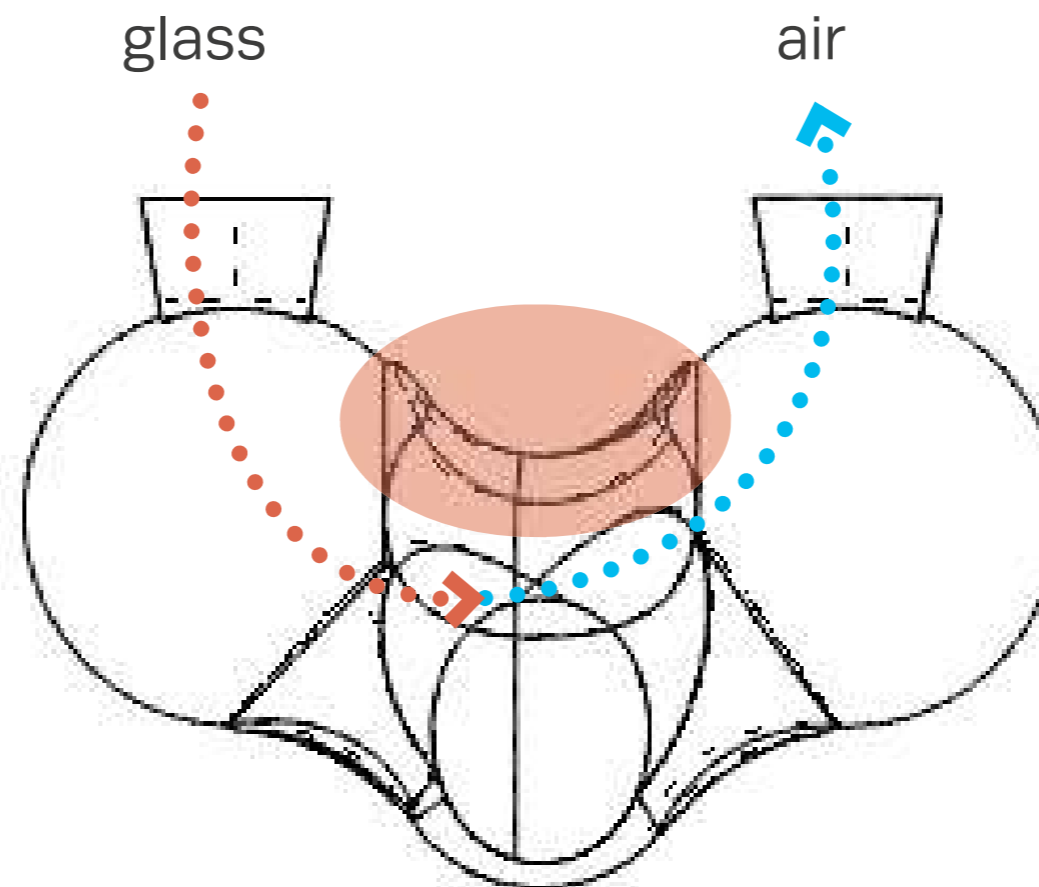

Final component: *First mold design...*

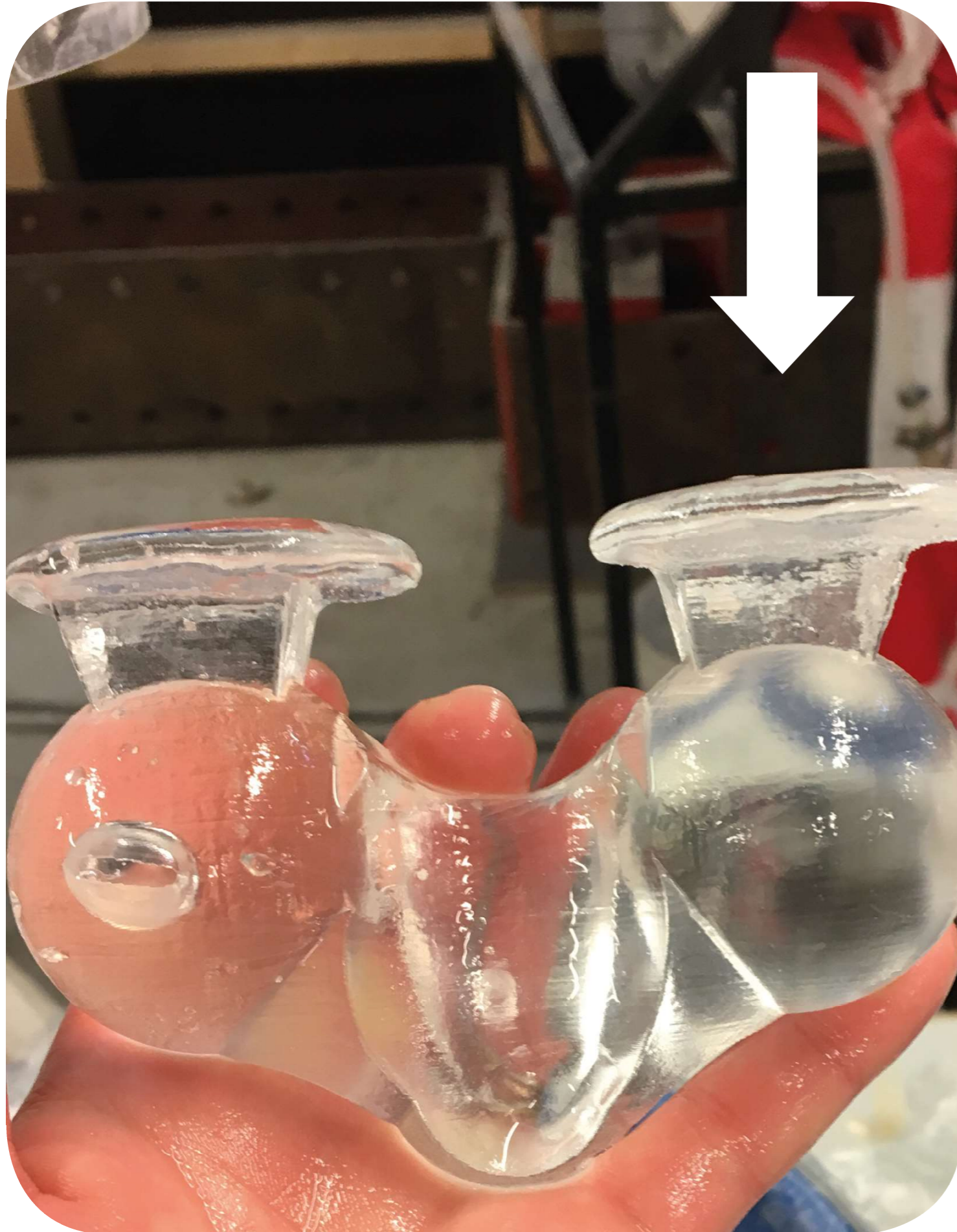

STEEL PRECISION MOLD + VENTS

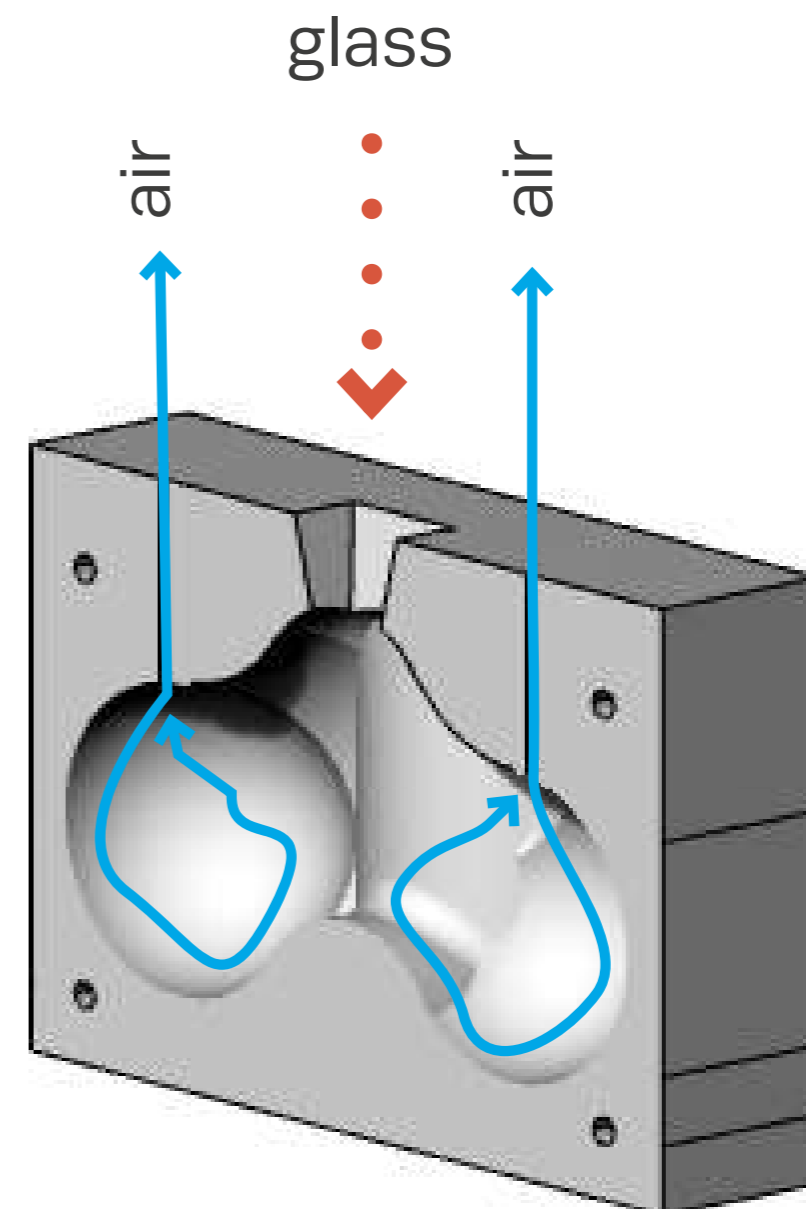
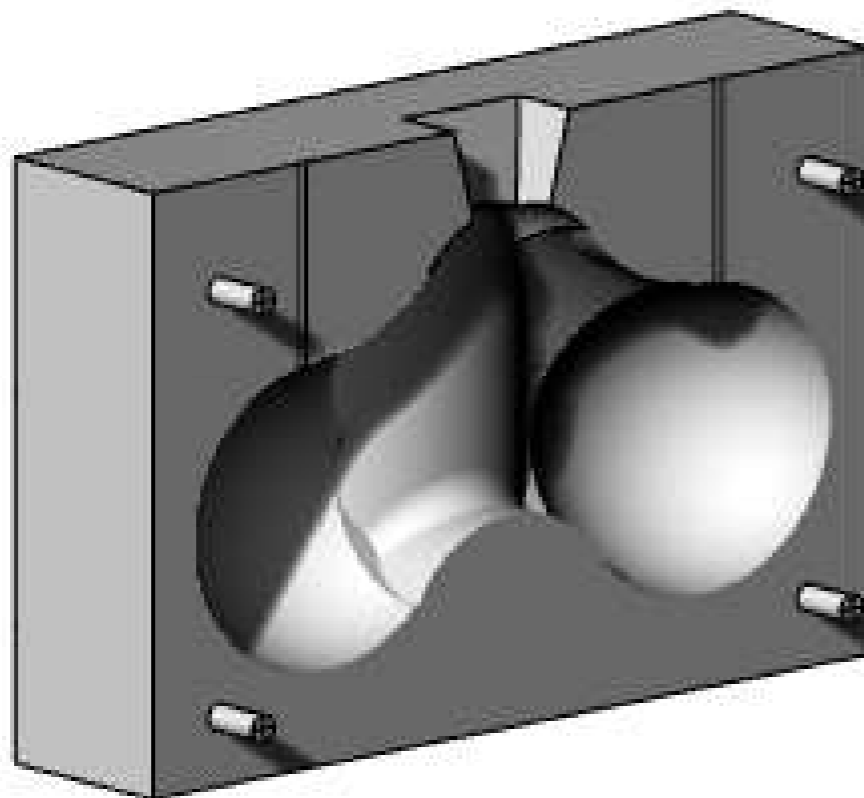



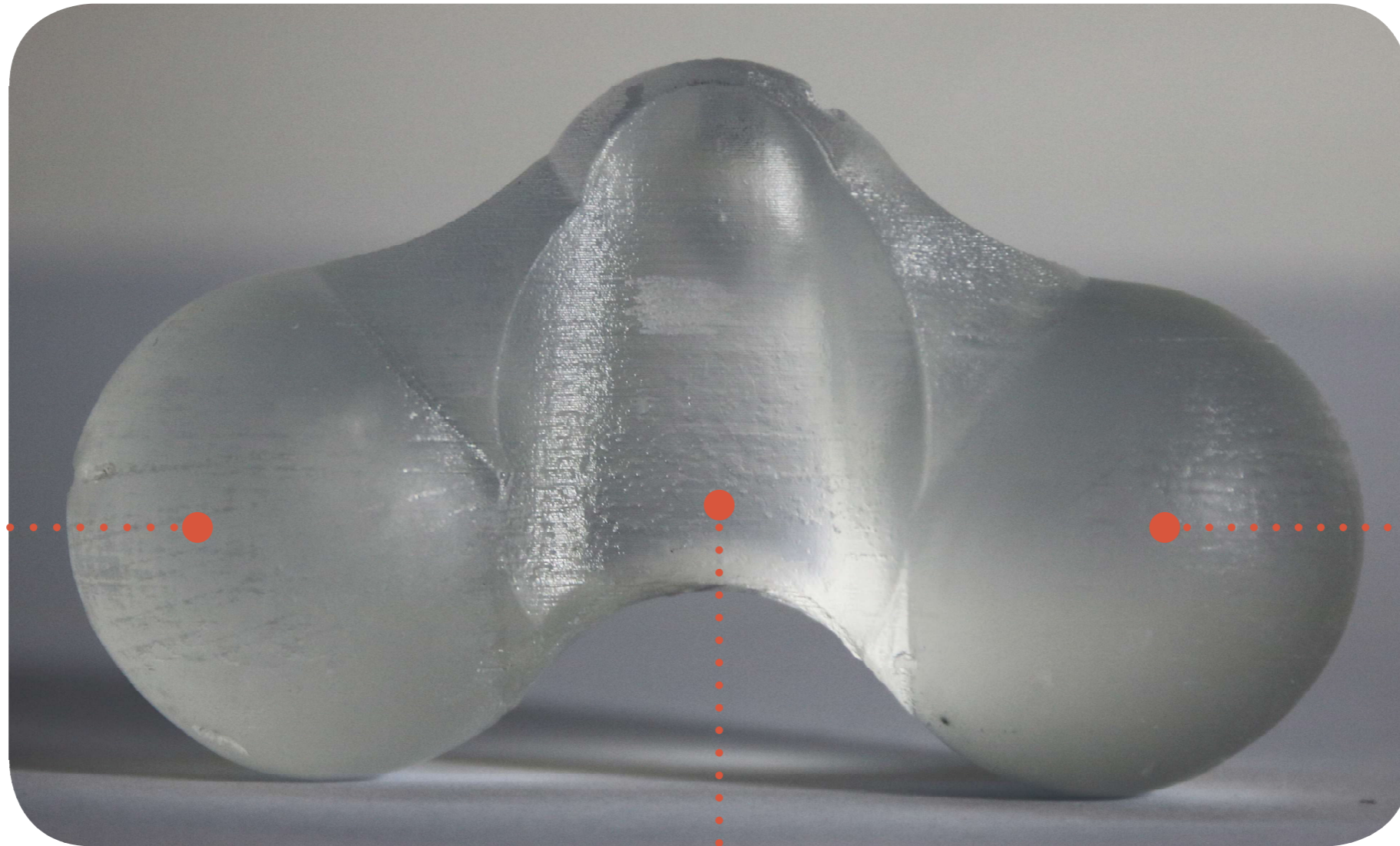

Positive lens <·····●

·····● > **Positive lens**

·····
↓
Negative

Final component: *Transparency*....

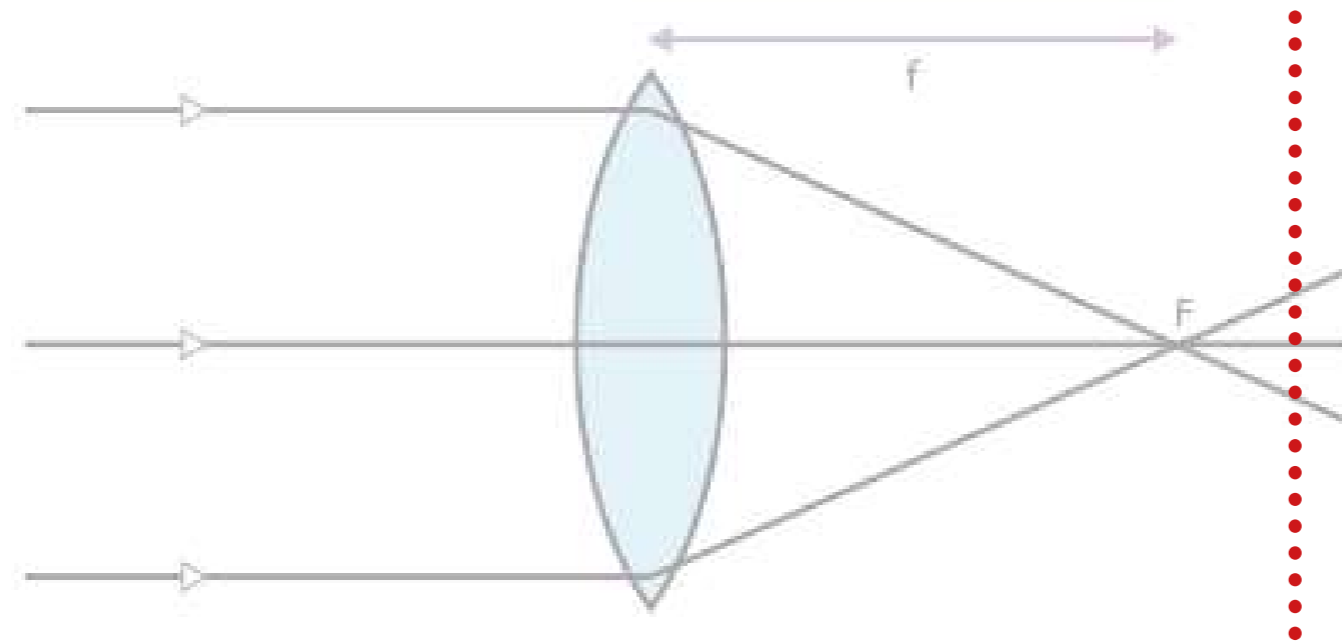
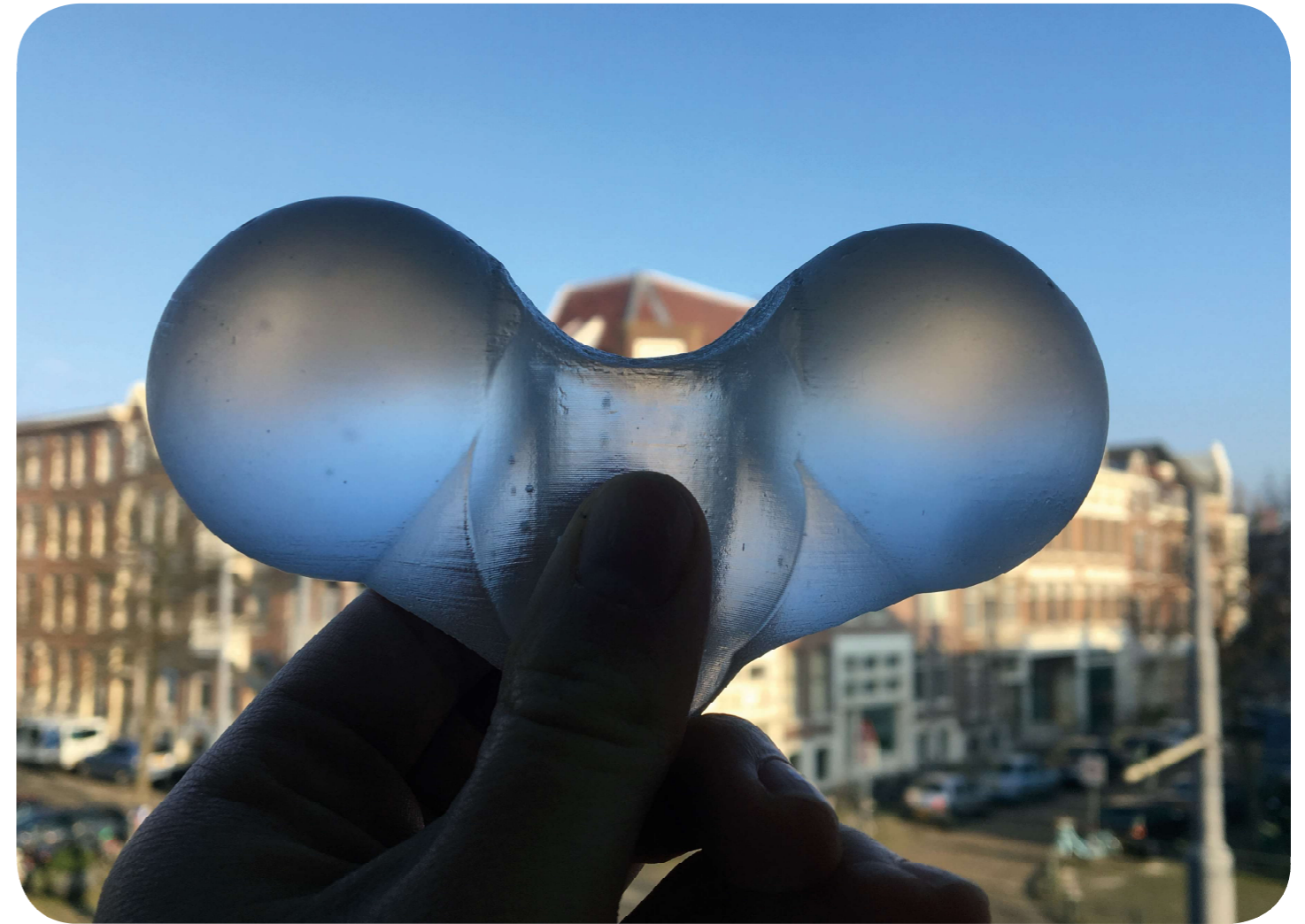

(source: www.denatuurkundefabriek.nl).

Final component: *Transparency*....

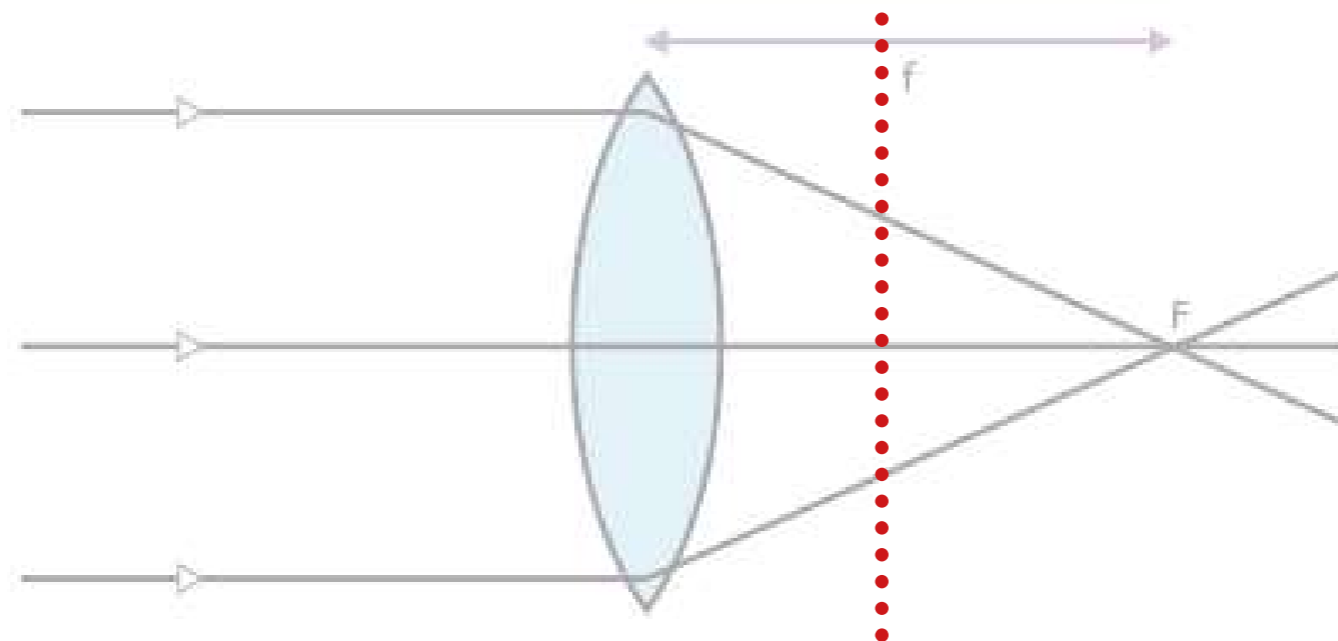

(source: www.denatuurkundefabriek.nl).

ARCH

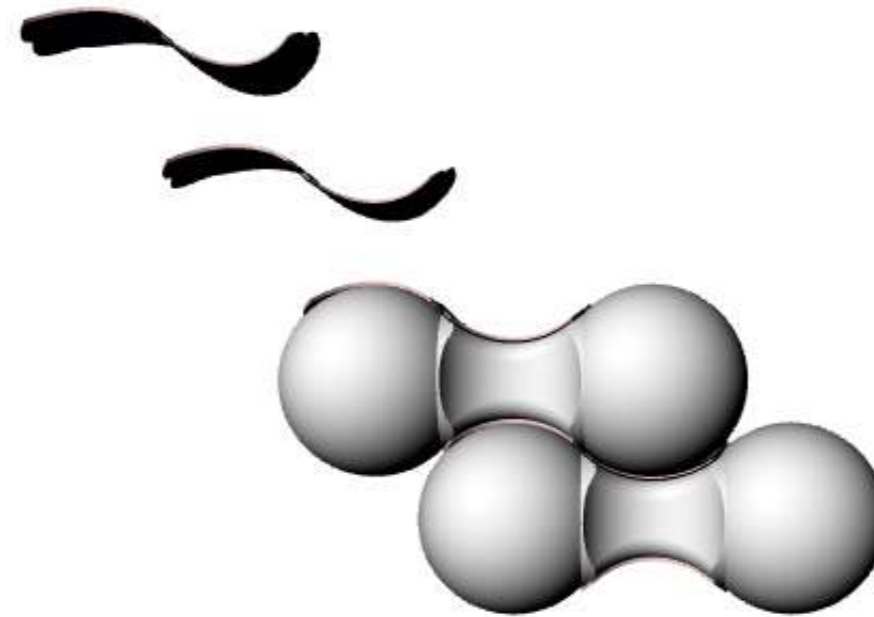
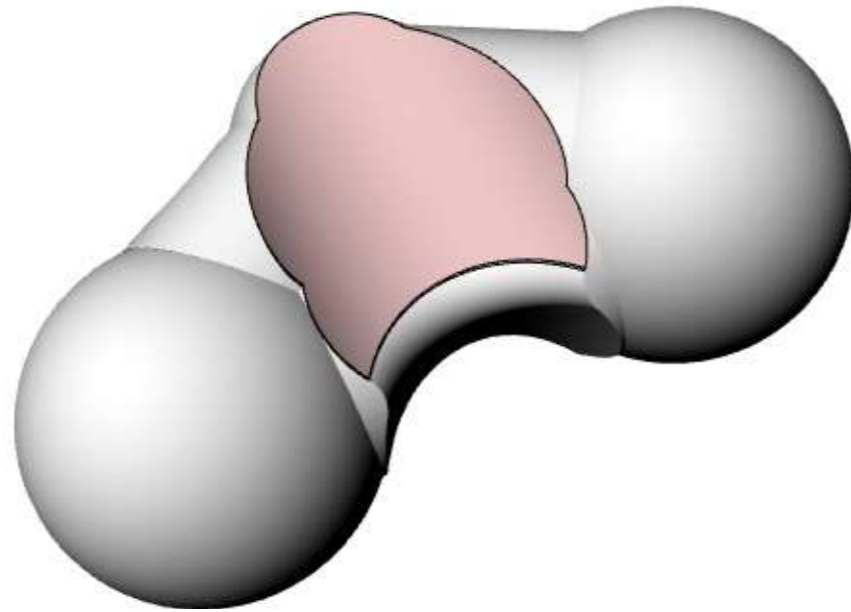

$t=2mm$

RING

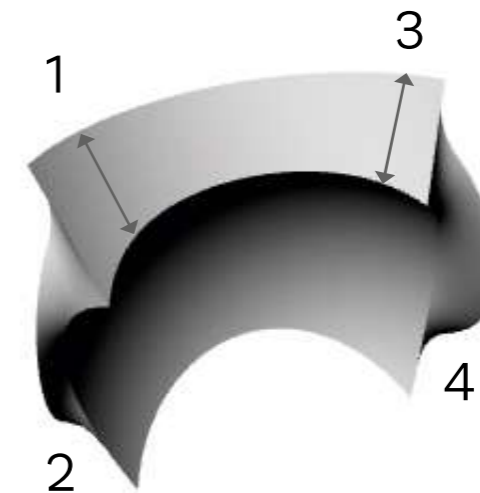
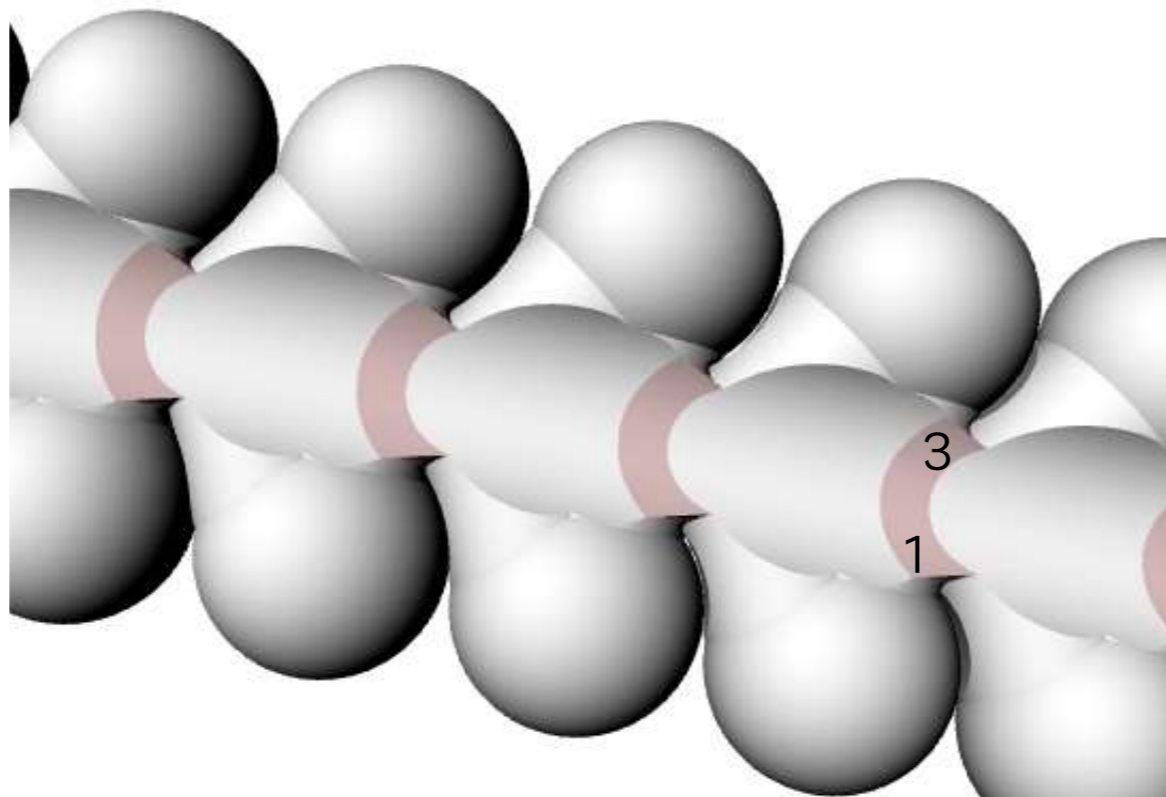

1&2 = 10,1-11,6 mm

3&4 = 10,1-12,0mm

Interlayer: *Ring layers...*

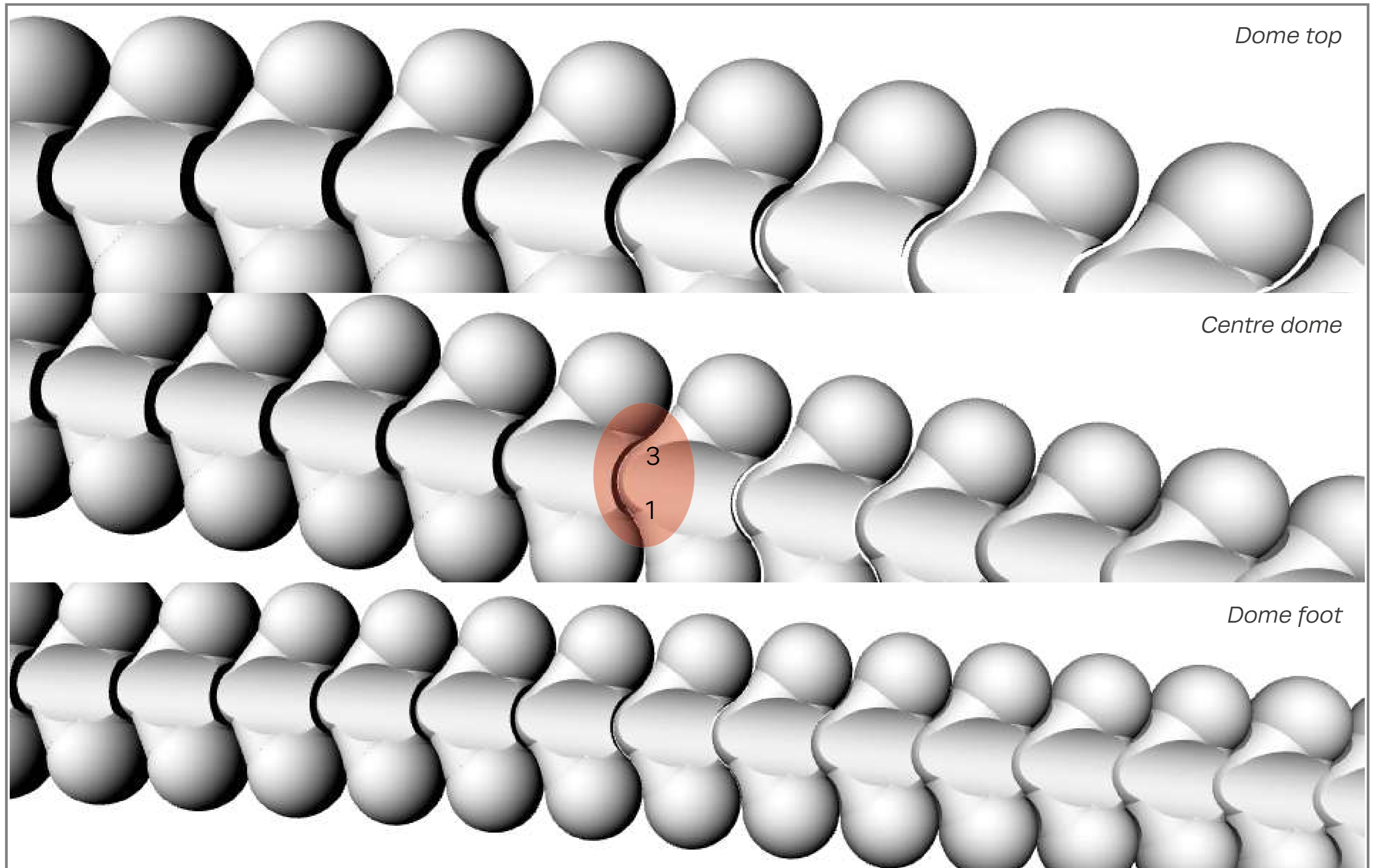

Interlayer: Optimization....

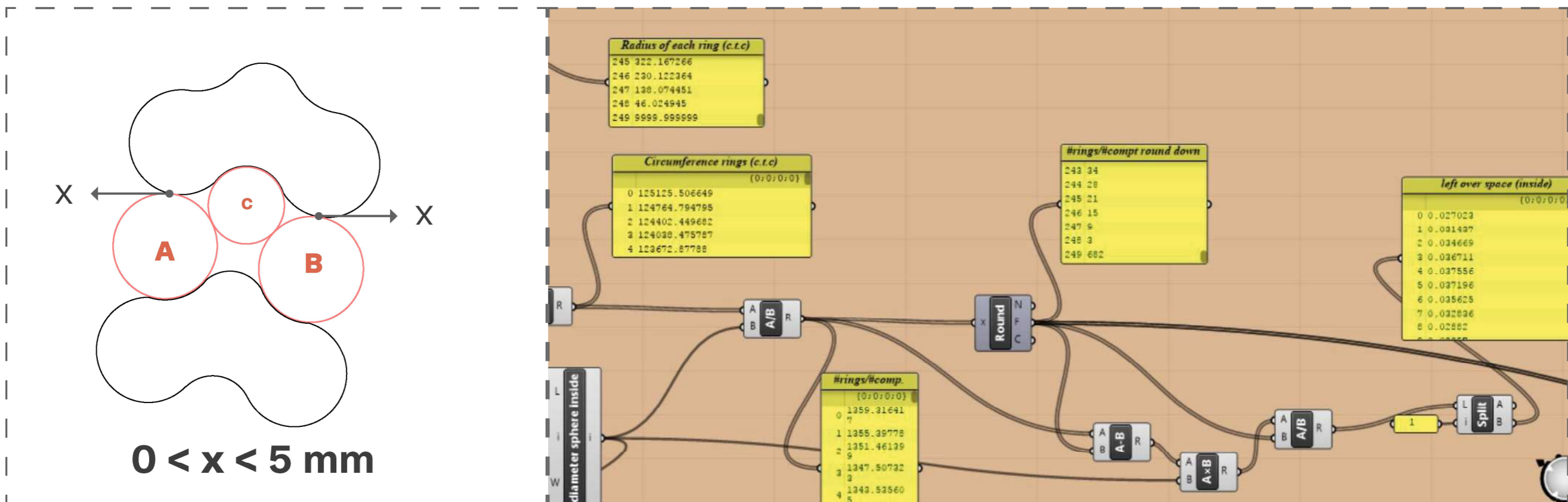
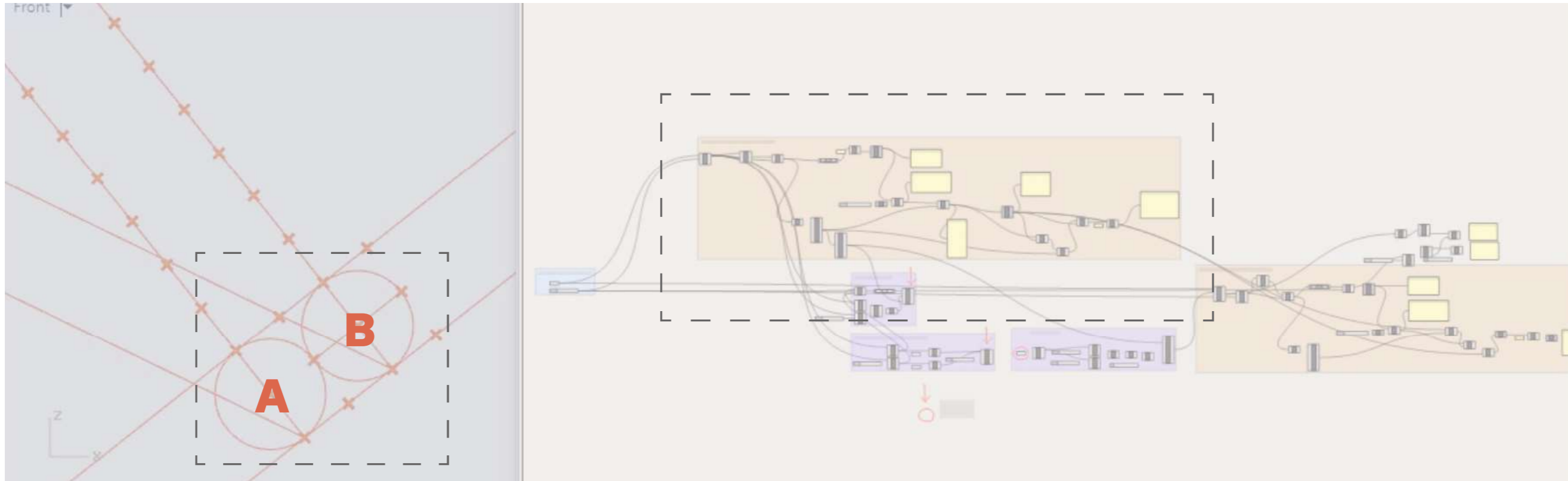

Feasibility: *Reference, Armadillo Vault....*



(Arthur, 2017).

Feasibility: Constructing the Glass Dome....

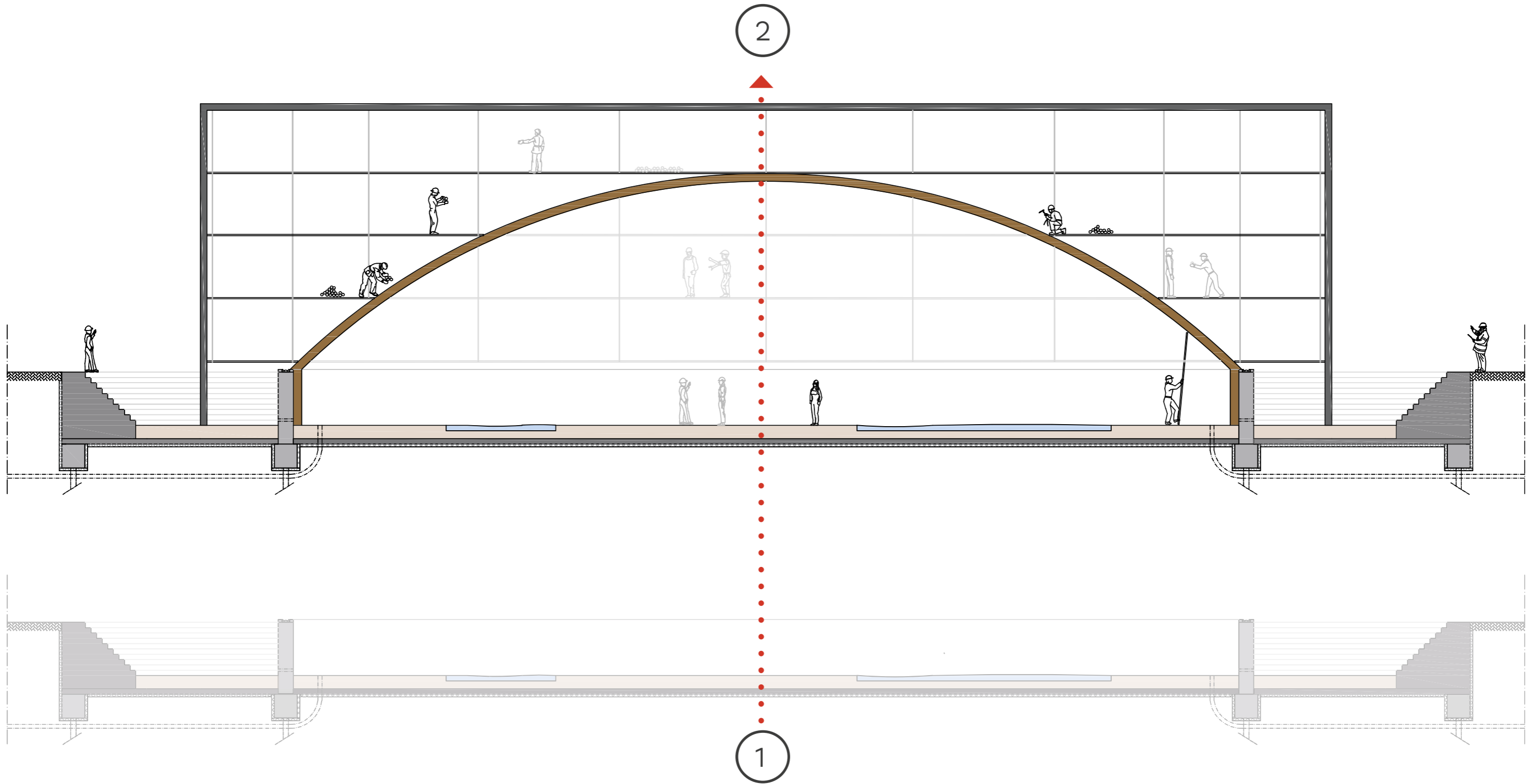

TOP

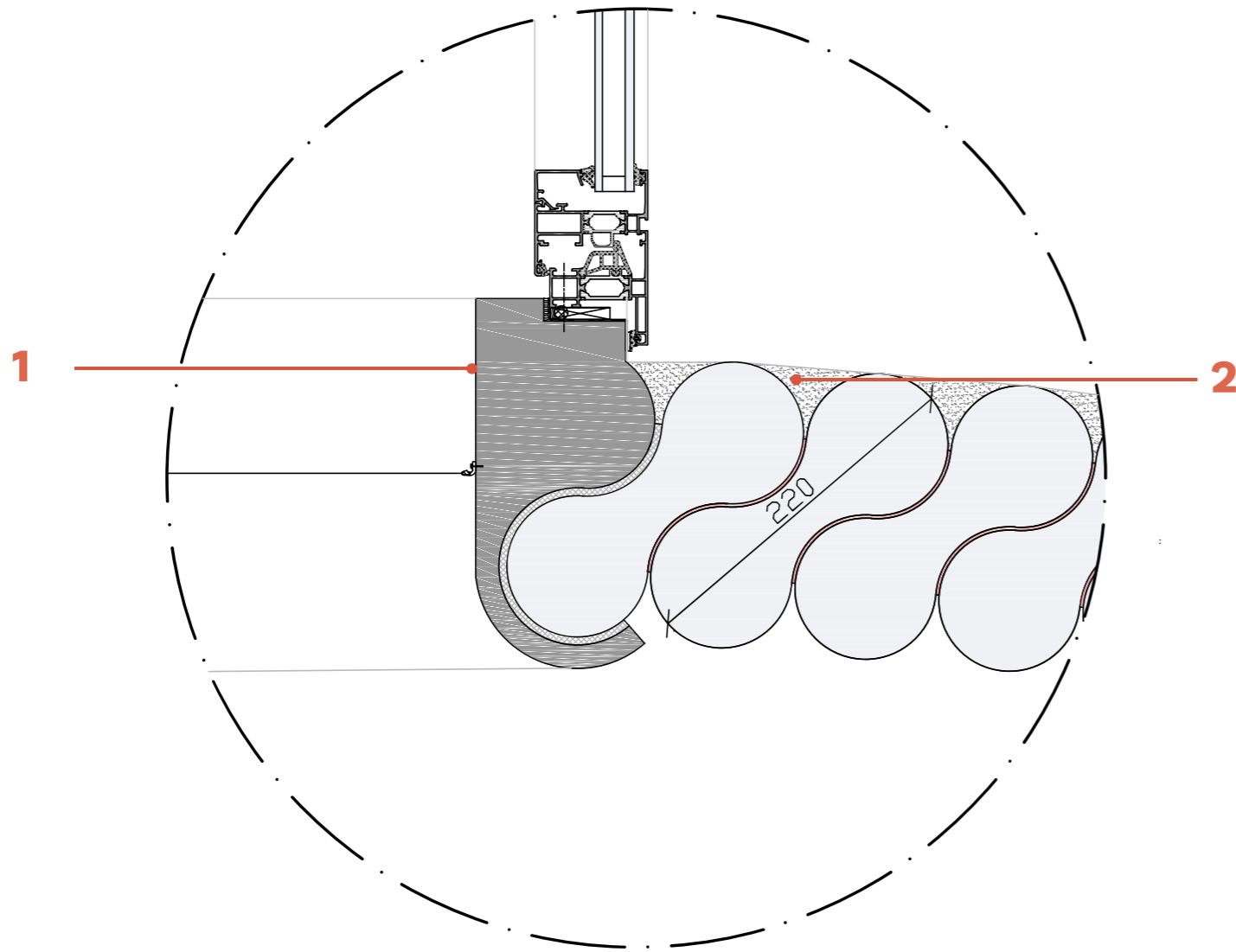

BASE

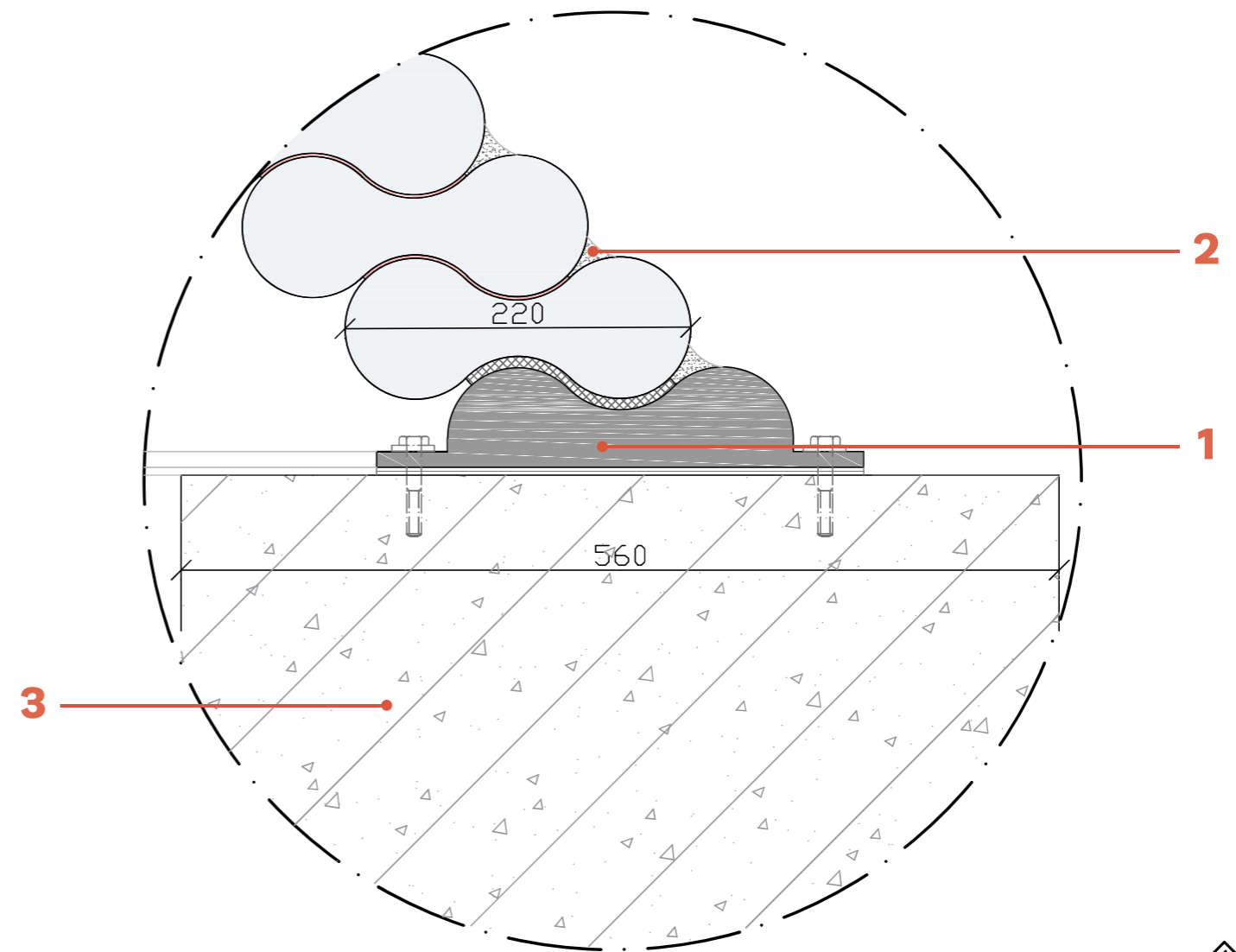

4. Validation

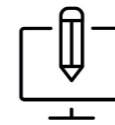

Structural performance | Thermal performance

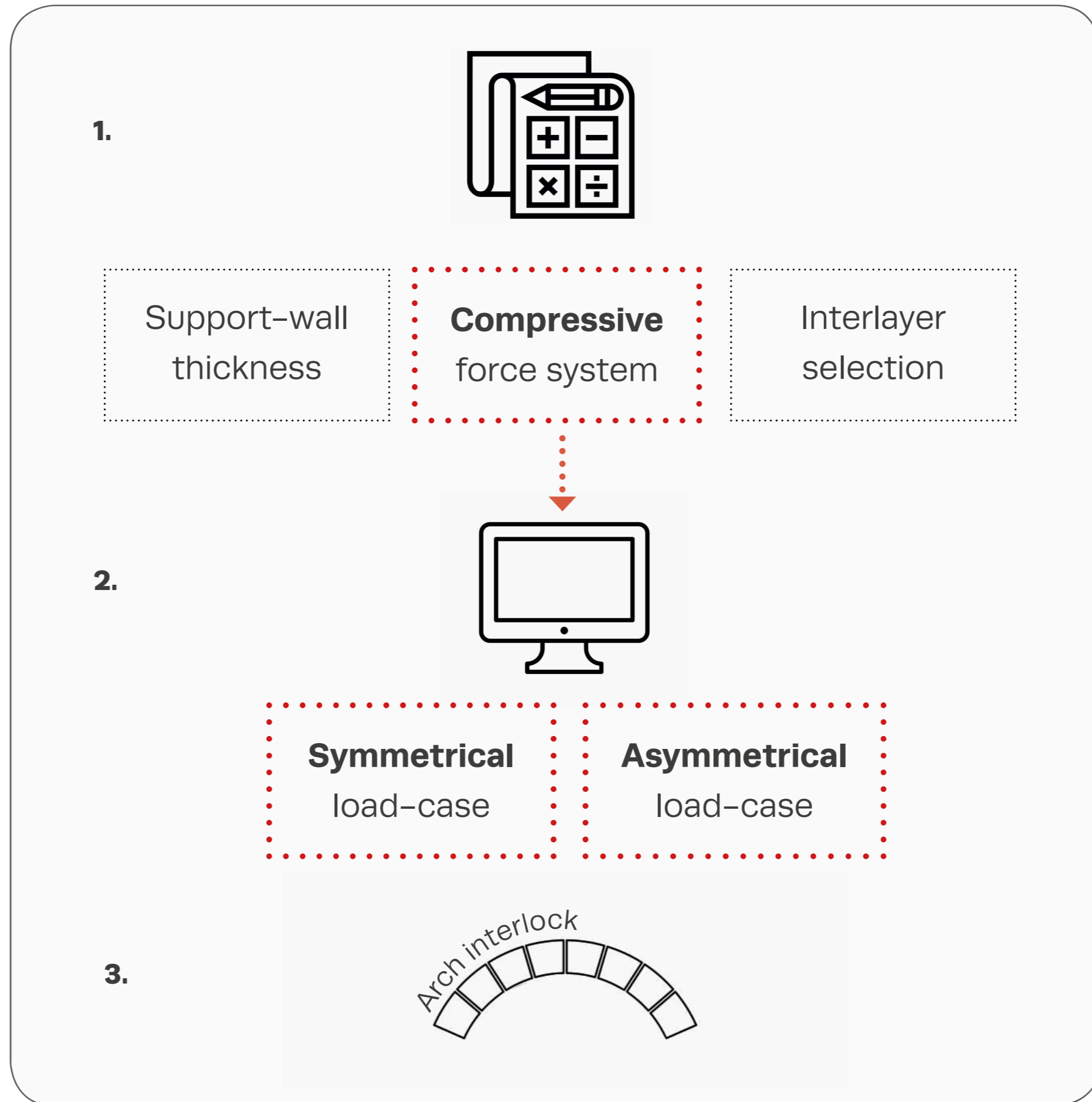

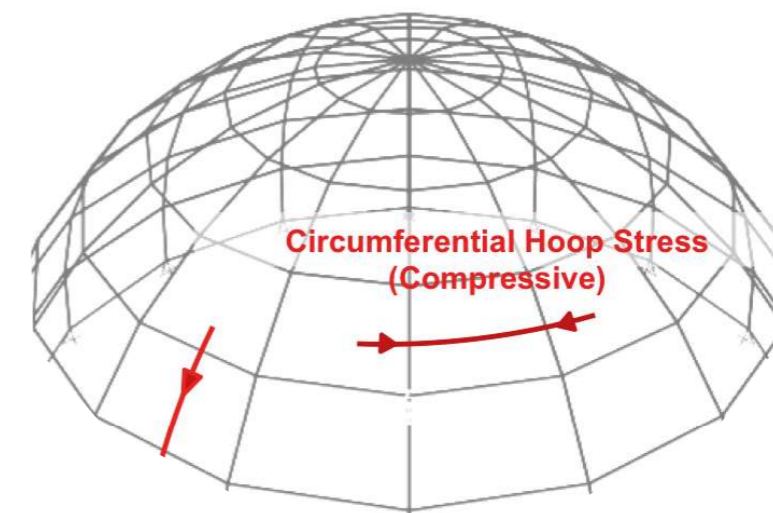
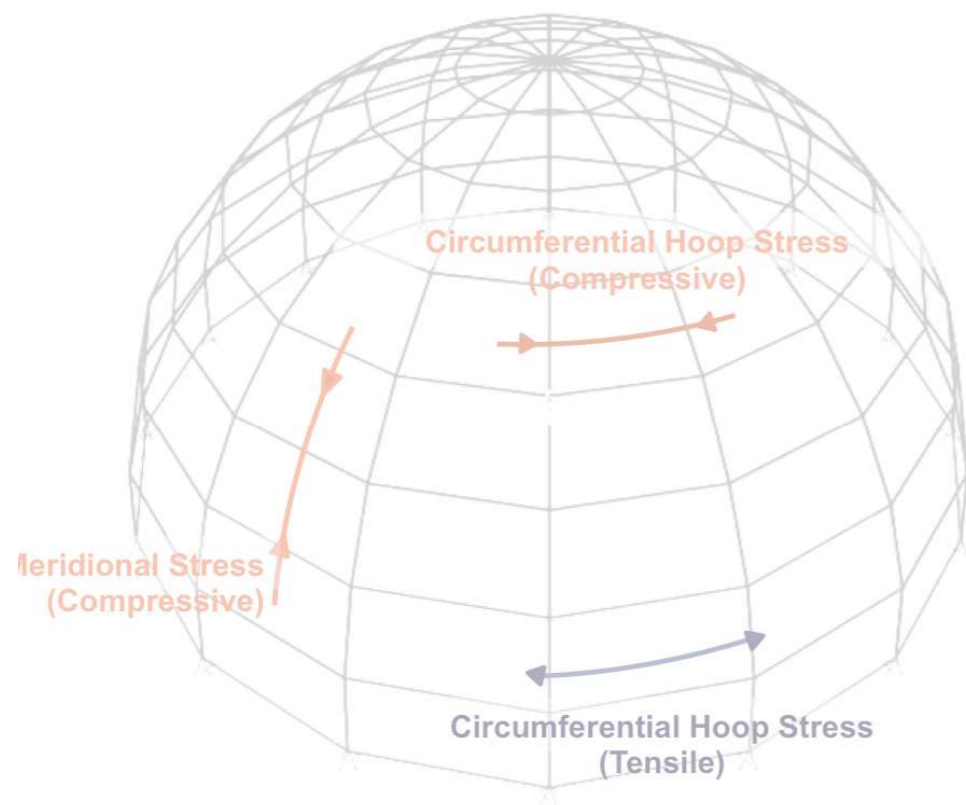
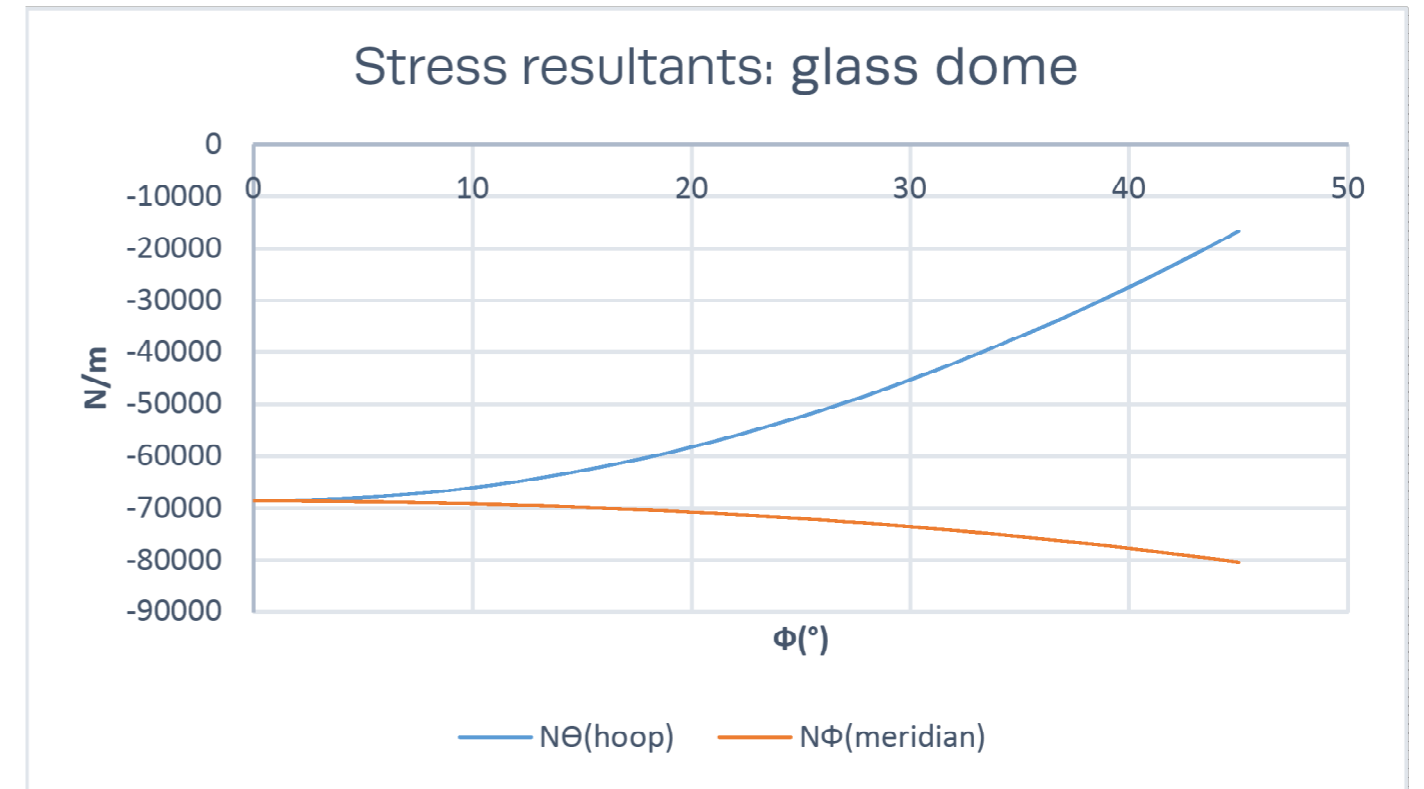
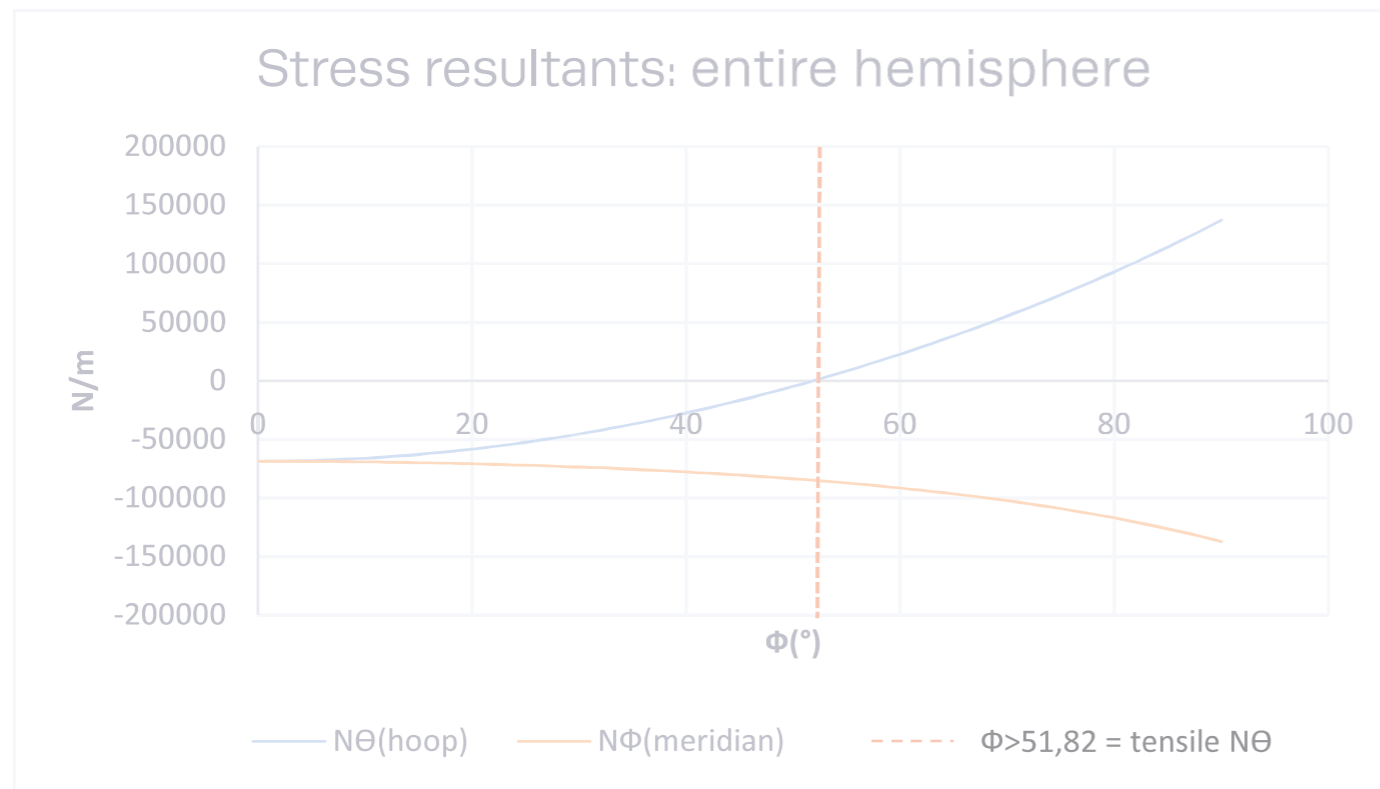

(source: <http://shells.princeton.edu/Balz.html>)

Structural validation: Wall thickness of the support structure....

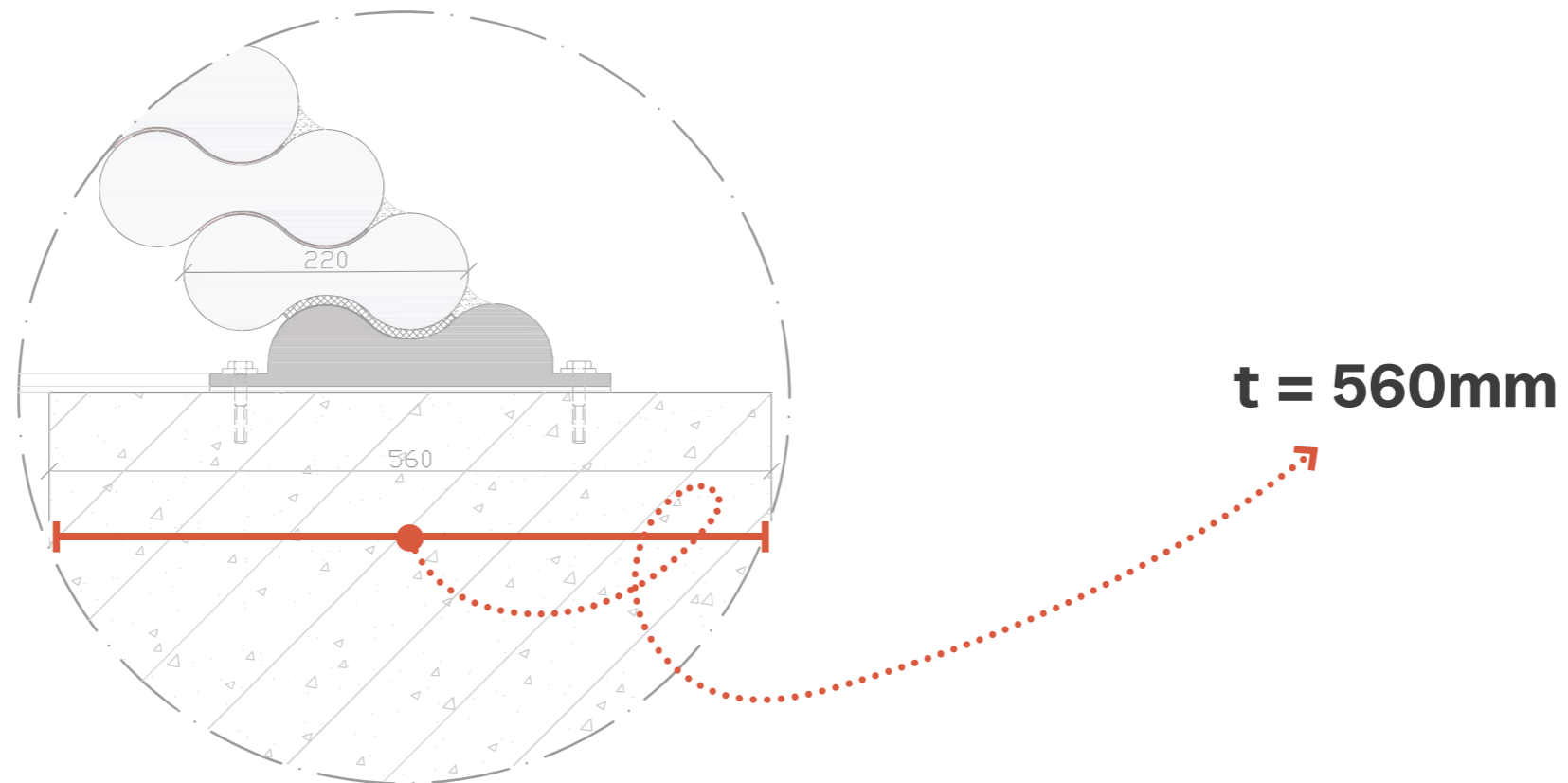
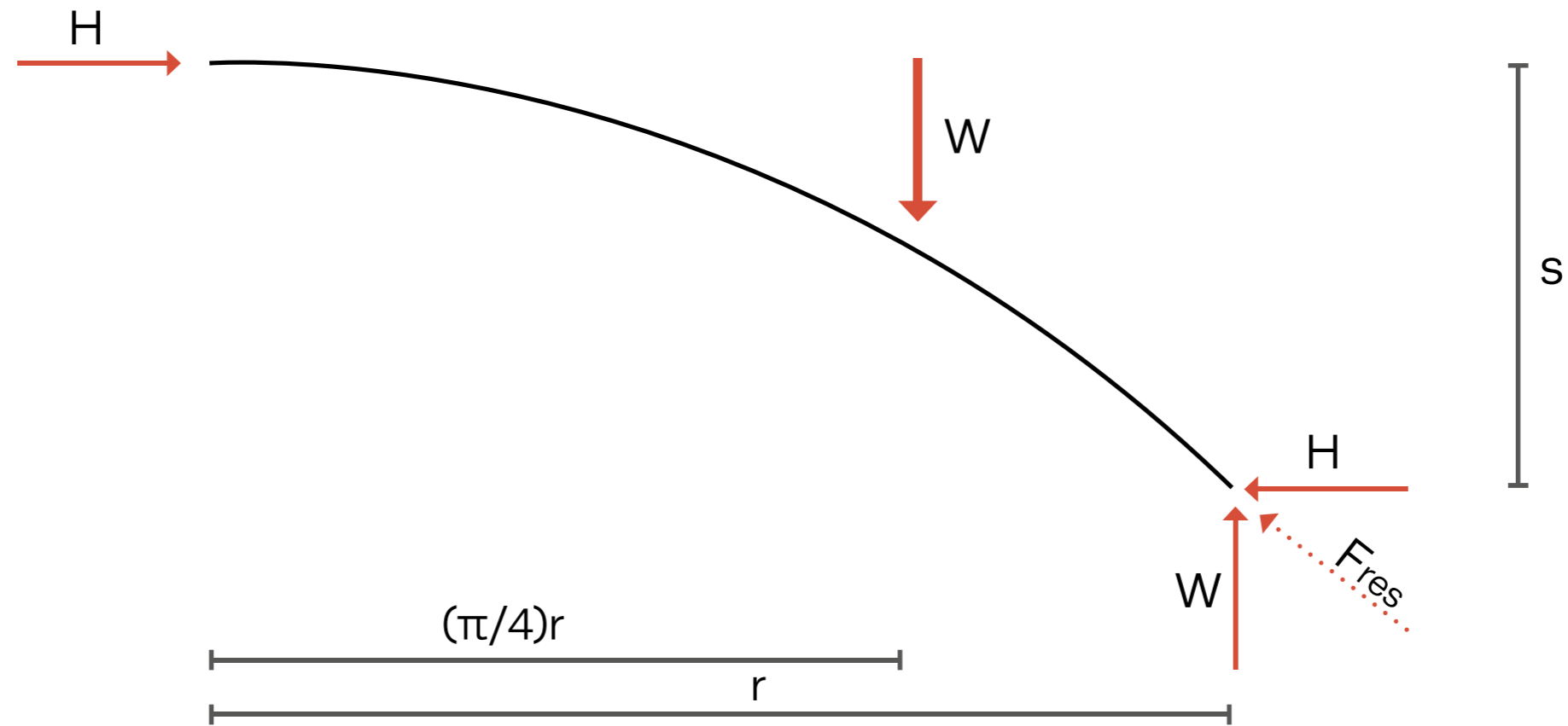

MATERIAL SELECTION

1. Structural requirements:

$$\sigma_{\text{contact}} \leq 20 \text{ MPa}$$

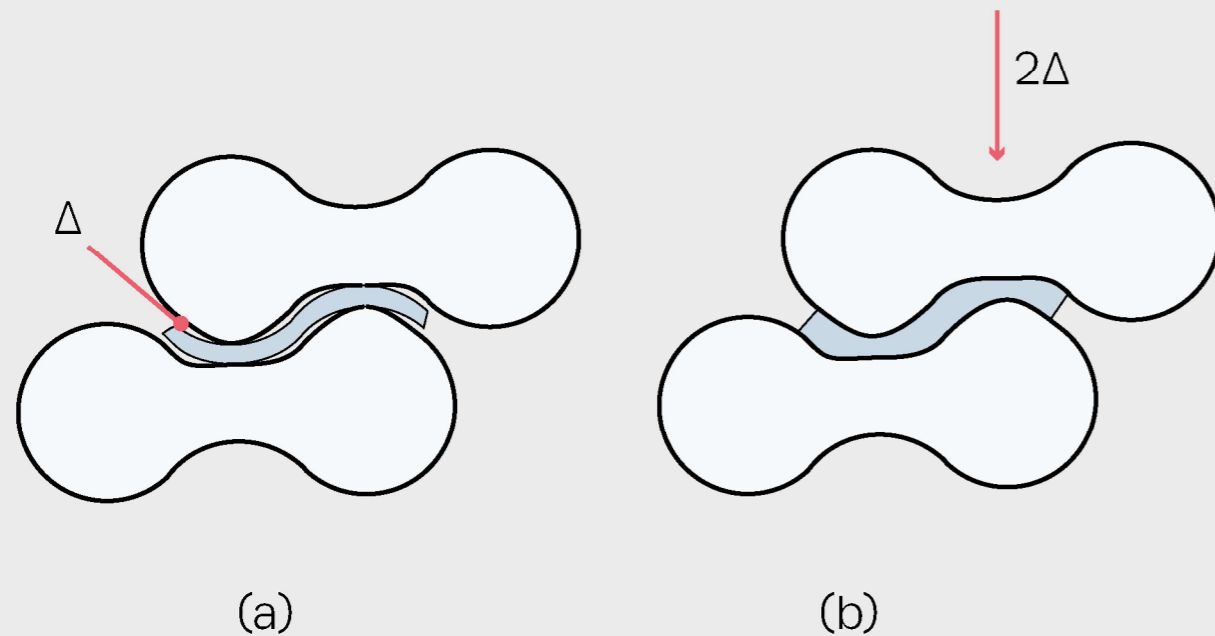

$$\sigma = E * \epsilon = E * (\Delta L / L)$$

$$\sigma_{\text{contact}} = E_{\text{int}} \frac{2\Delta}{t_{\text{int}}}$$

$$E_{\text{int}} / t_{\text{int}} \leq 20 / (2 * 0,25) \leq 40 \text{ N/mm}^3$$

2. General requirements:

- Optical quality/transparent
- Durable
- Service temp: > 50°C

3. Manufacturing requirements:

- Thickness: 2-12mm
- Solid complex 3D

TPU & Compression molding

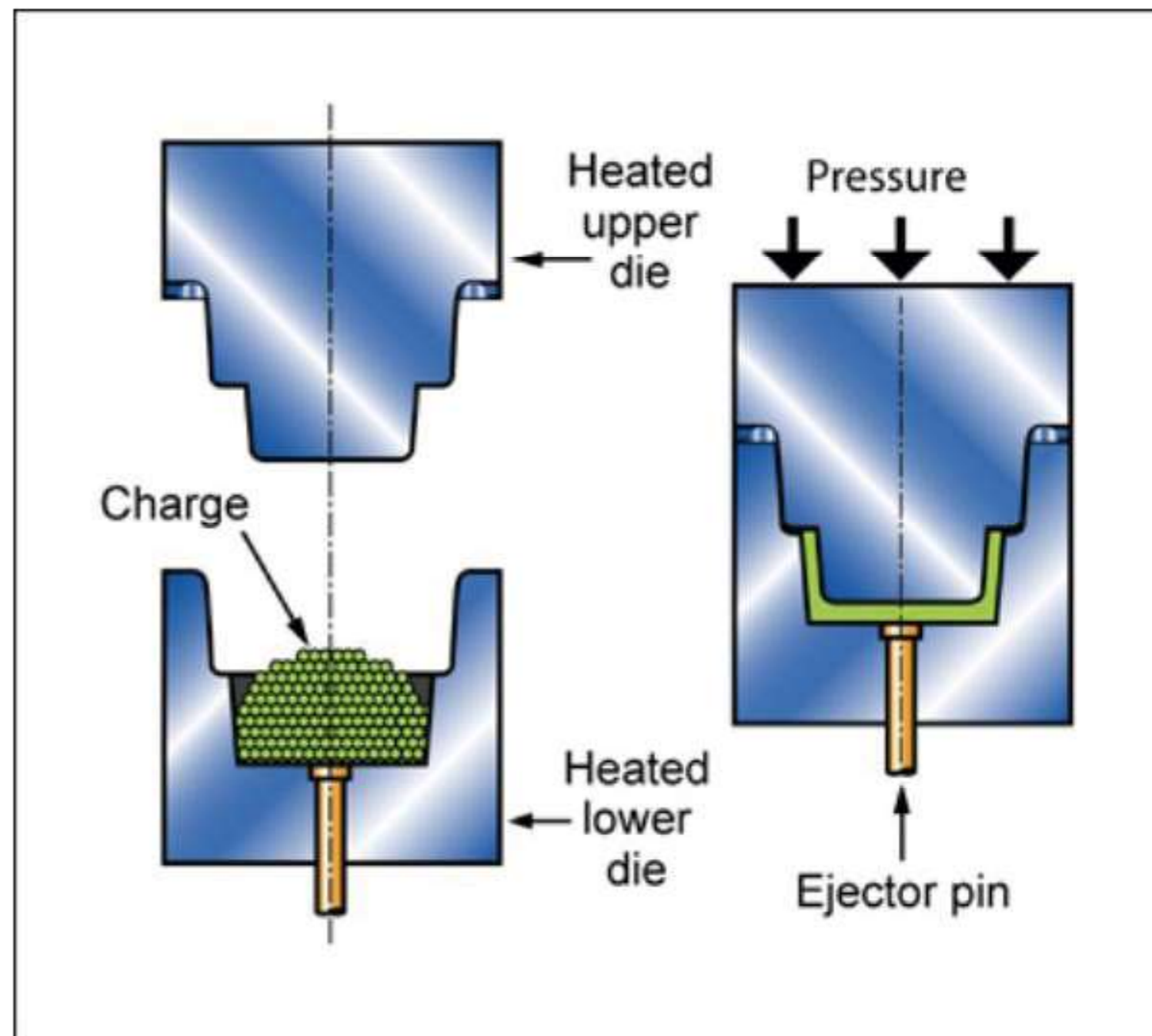
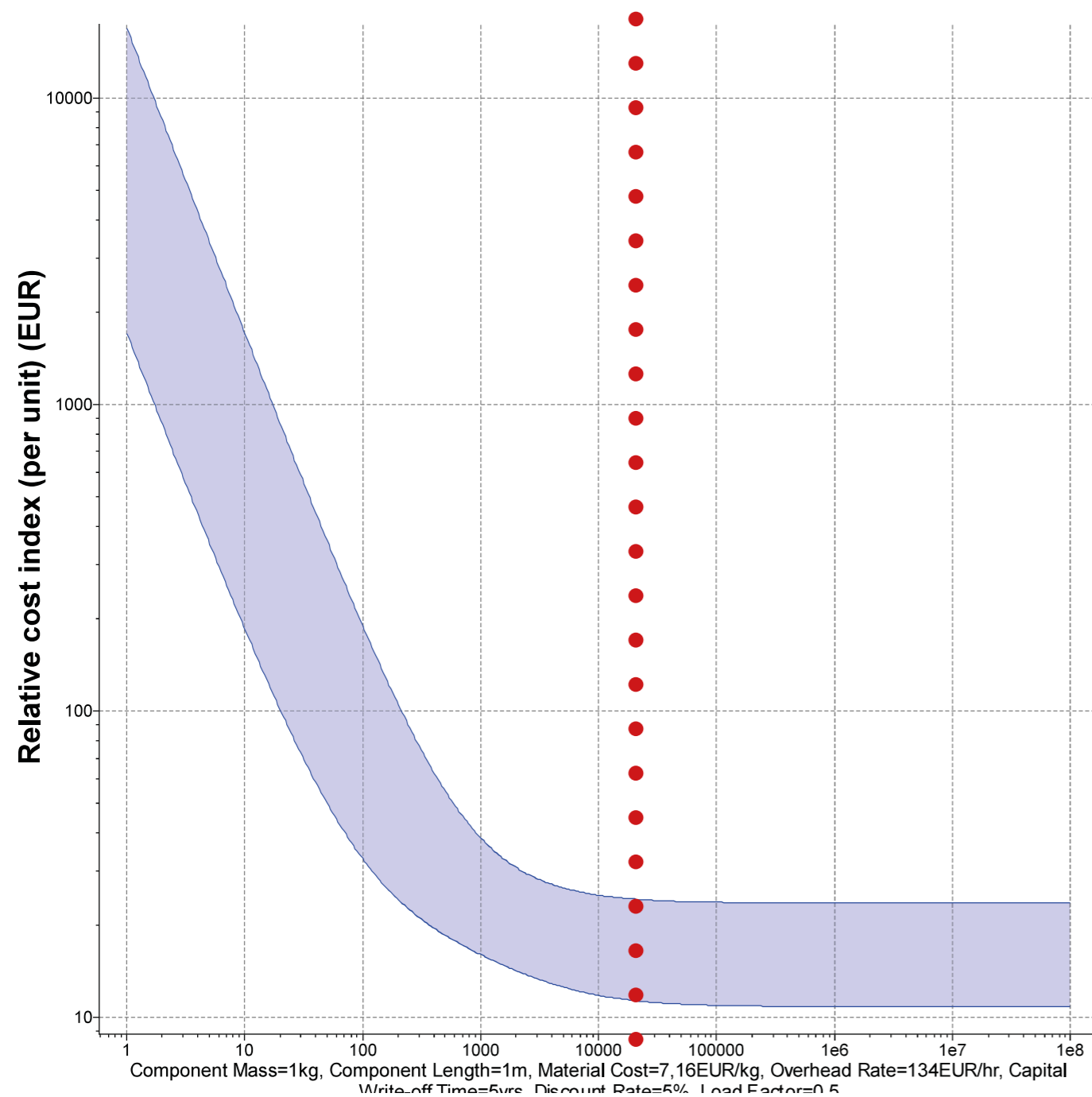

• • • • Amount interlayers glass dome

TPU



(source: www.nl.aliexpress.com)

Compressive force system

LC1: Self-weight

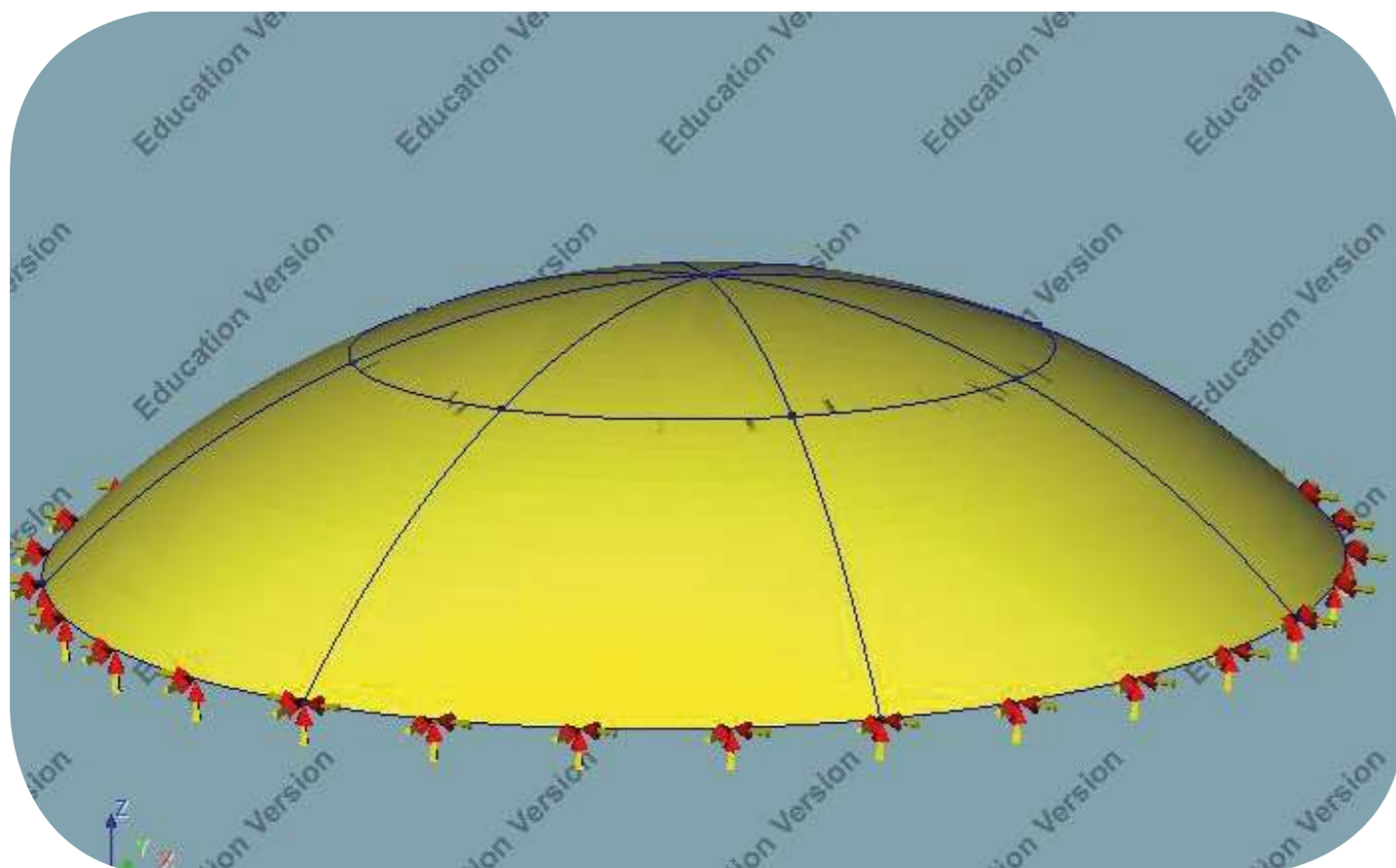

LC2: Self-weight + Wind

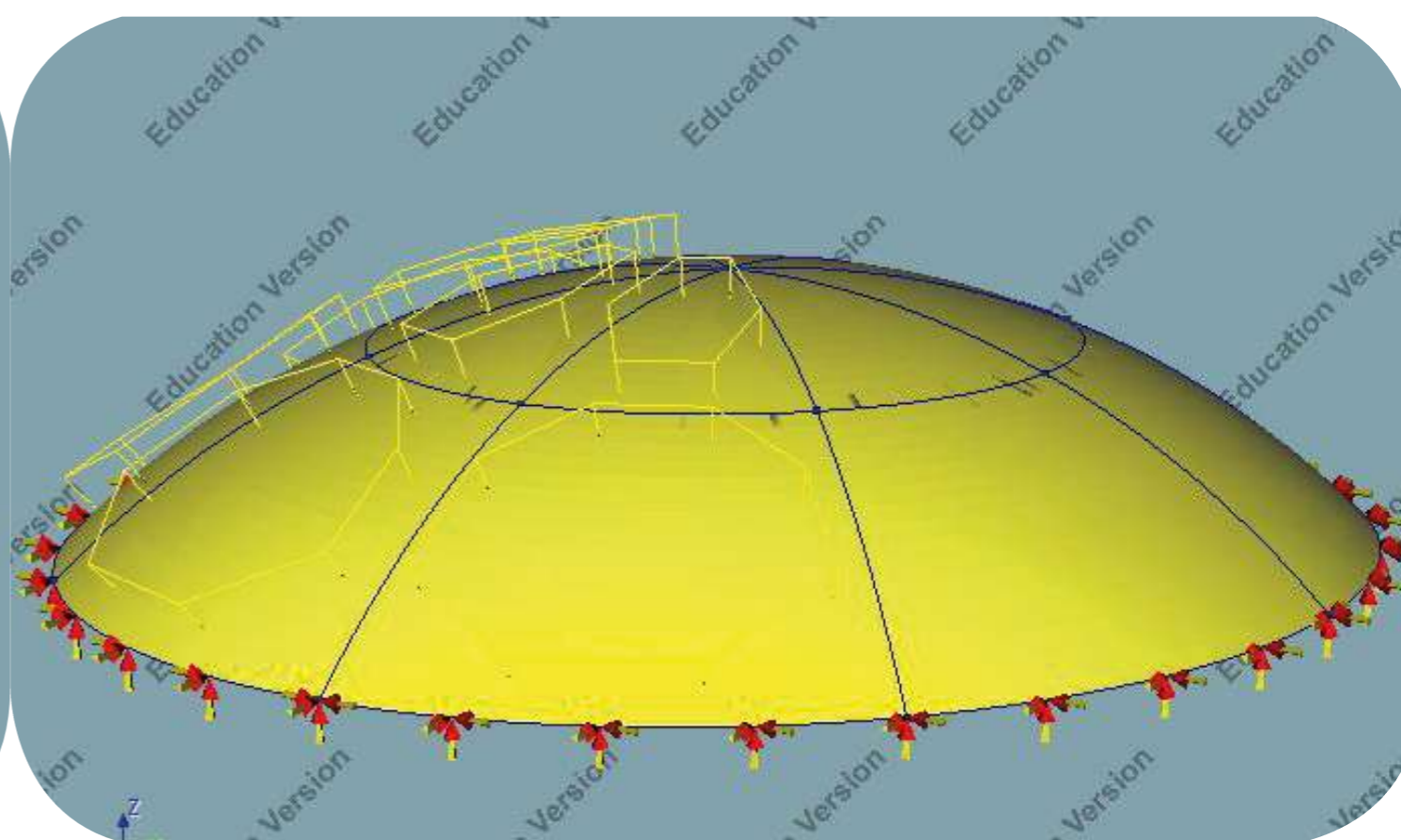



Resultants **arch** (Nxx)

LC1: Self-weight

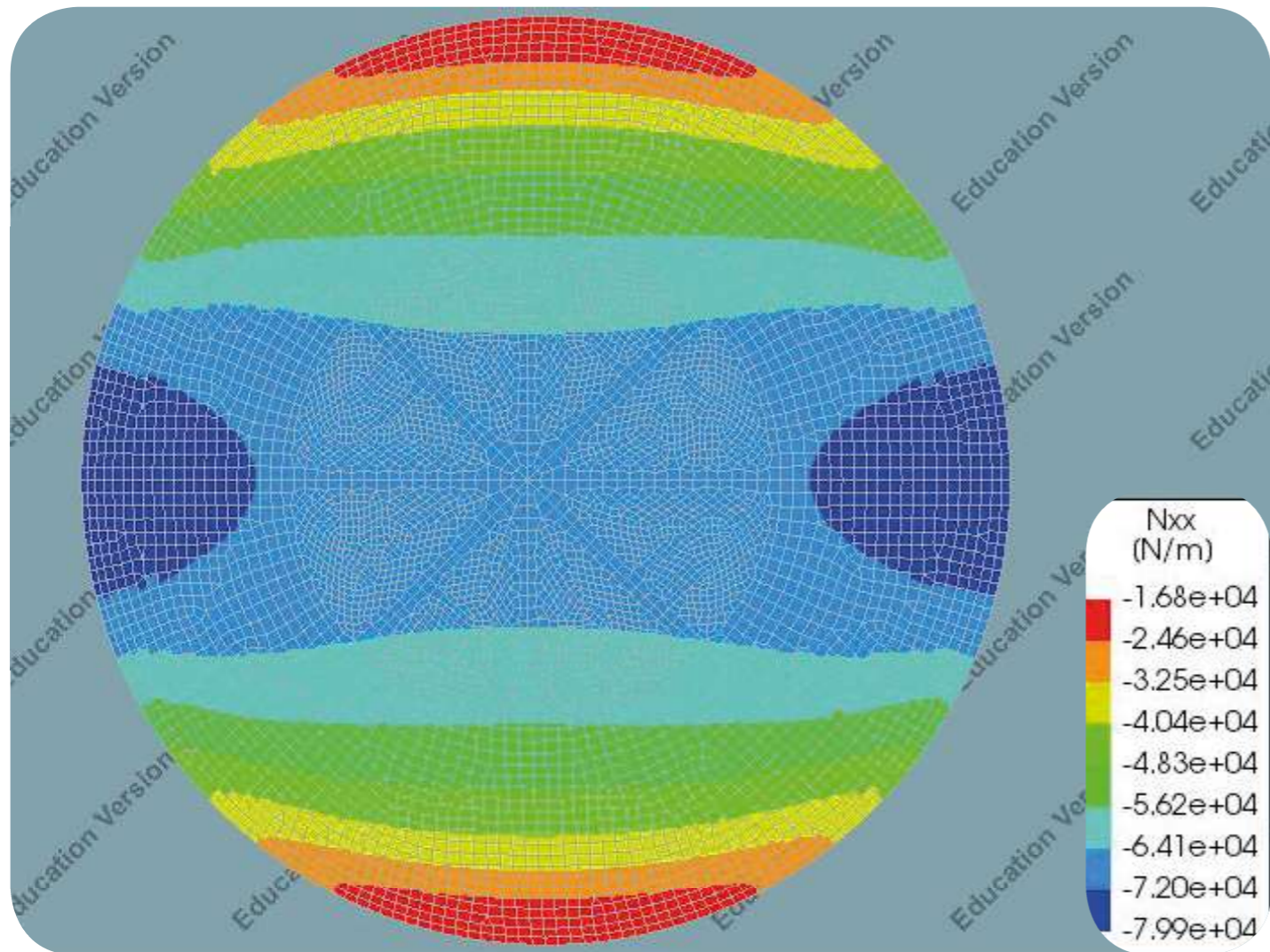

LC2: Self-weight + Wind

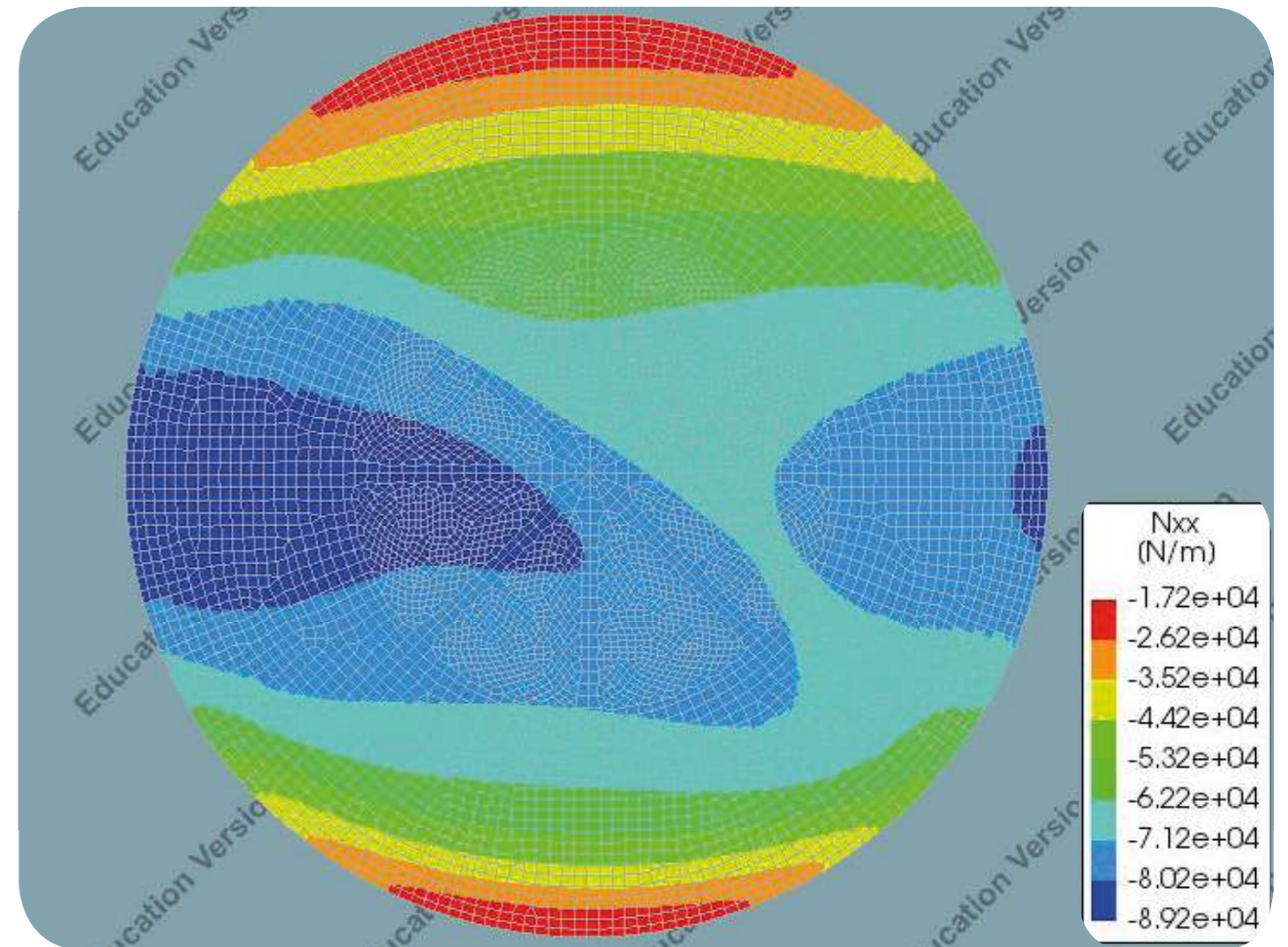



Resultants **ring** (Nyy)

LC1: *Self-weight*

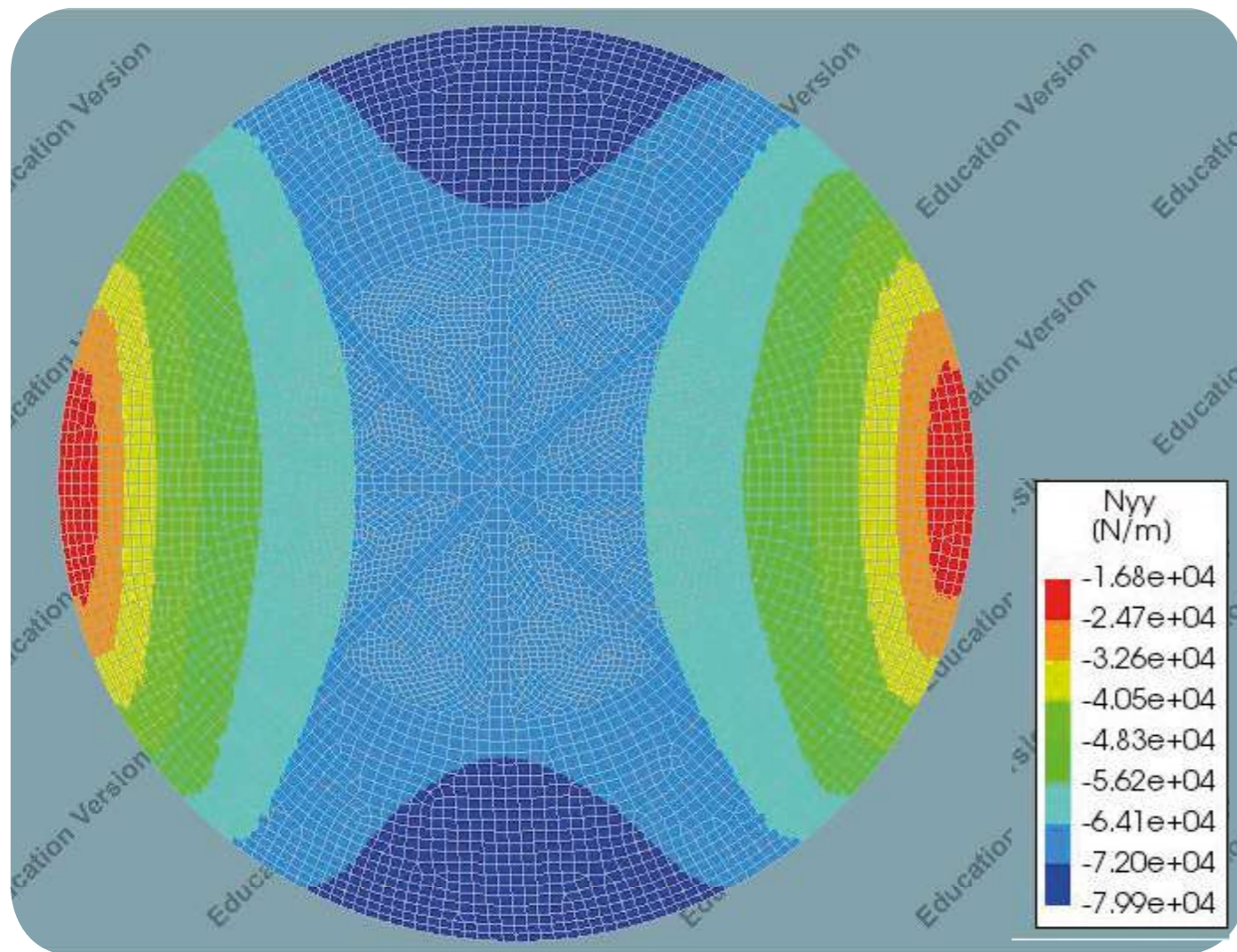

LC2: *Self-weight + Wind*

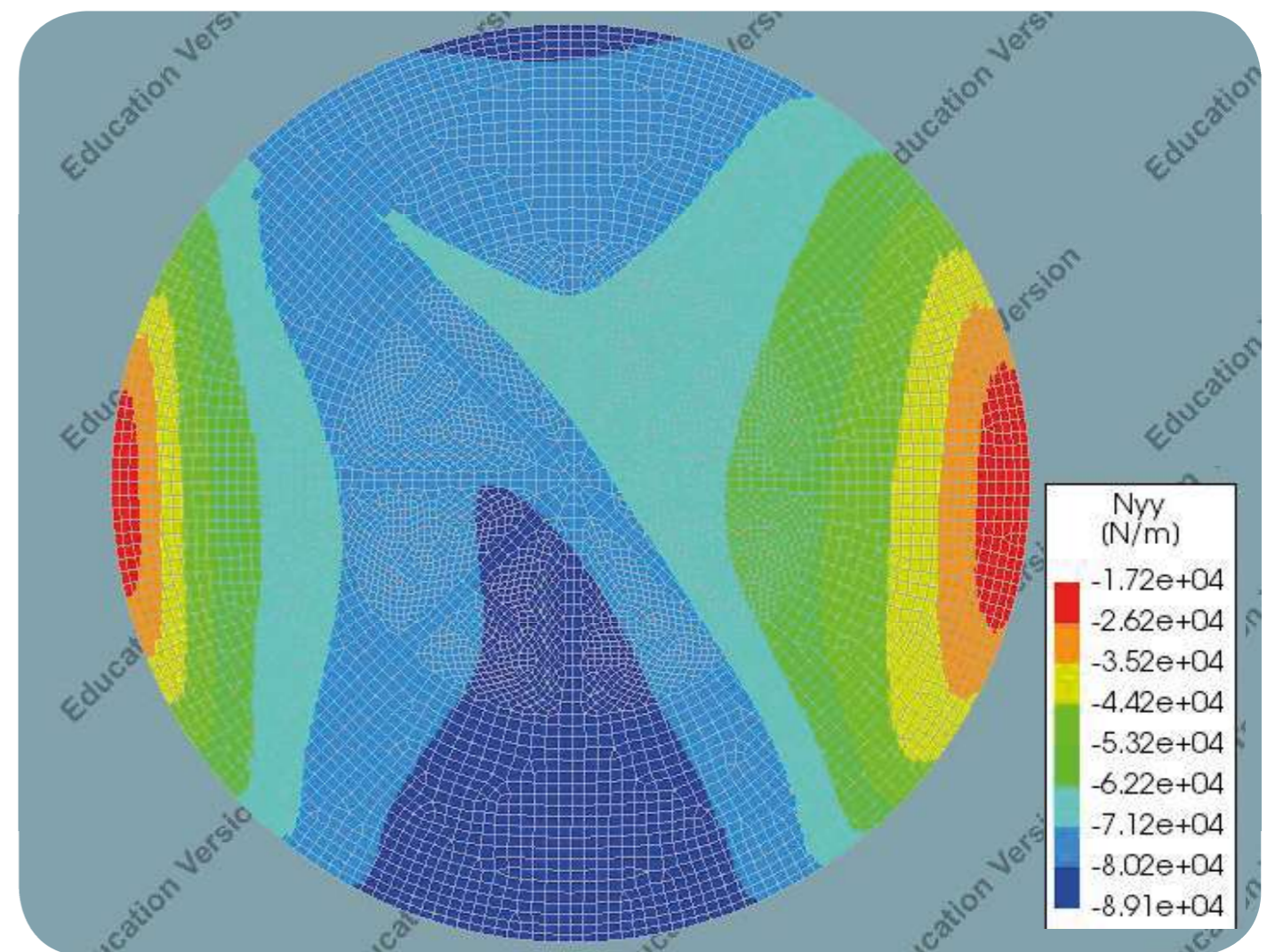

**LC1
(symmetrical)**

**LC2
(asymmetrical)**

Stress resultants (N/m * e^4)

<i>direction</i>		Diana	Hand	Diana
		<i>LC 1 (Sym)</i>	<i>LC 1 (Sym)</i>	<i>LC2 (Asym)</i>
<i>Ring</i>	top	-6,41	-6,86	-7,12
	base	-1,68	-1,67	-1,72
<i>Arch</i>	top	-6,41	-6,86	-7,12
	base	-7,99	-8,04	-8,92



**LC1
(symmetrical)**

**LC2
(asymmetrical)**

Stress resultants (N/m *e^4)

<i>direction</i>		Diana	Hand	Diana
		<i>LC 1 (Sym)</i>	<i>LC 1 (Sym)</i>	<i>LC2 (Asym)</i>
<i>Ring</i>	top	-6,41	-6,86	-7,12
	base	-1,68	-1,67	-1,72
<i>Arch</i>	top	-6,41	-6,86	-7,12
	base	-7,99	-8,04	-8,92



Maximum **principle stress** (S3)

LC1: *Self-weight*

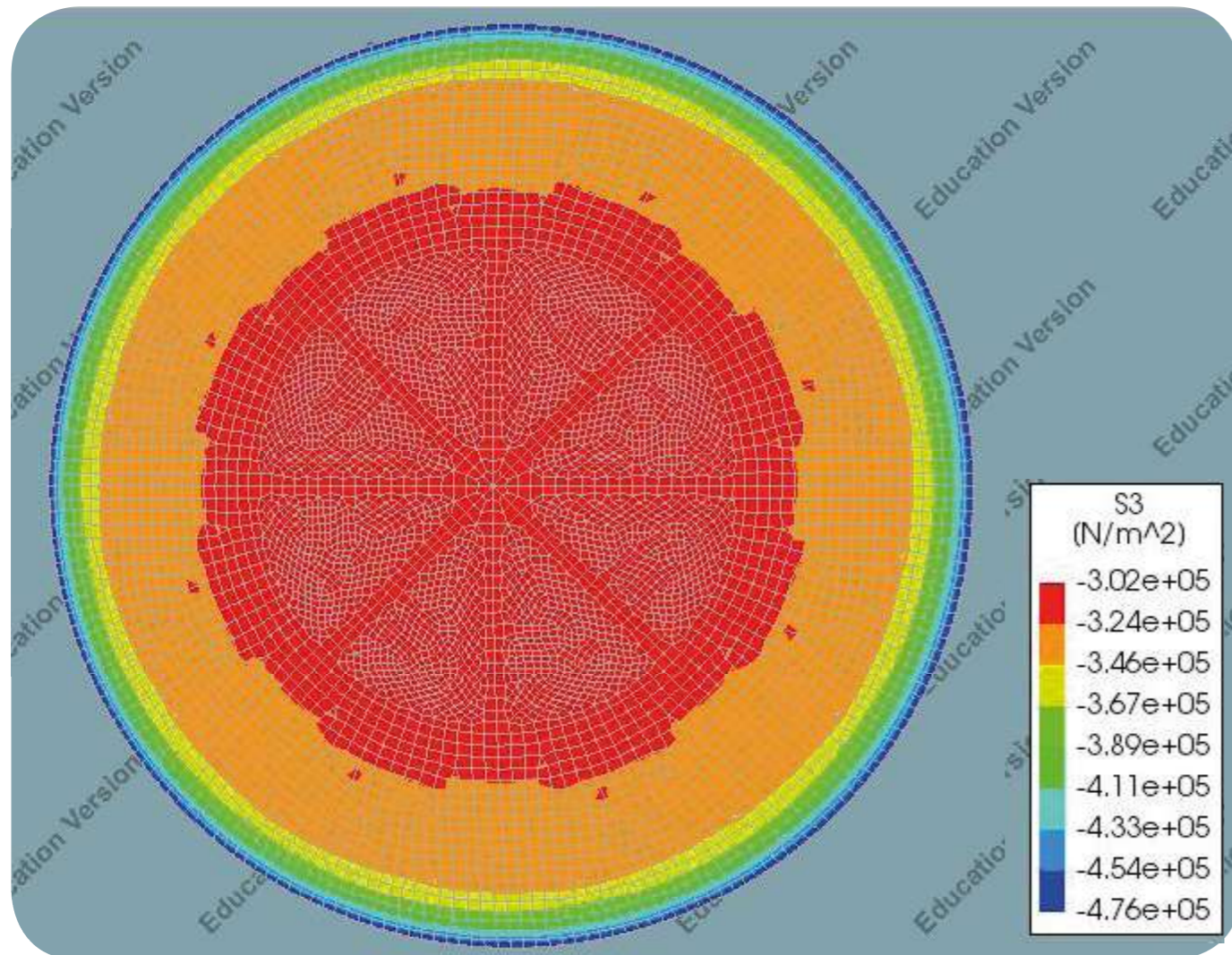

LC2: *Self-weight + Wind*

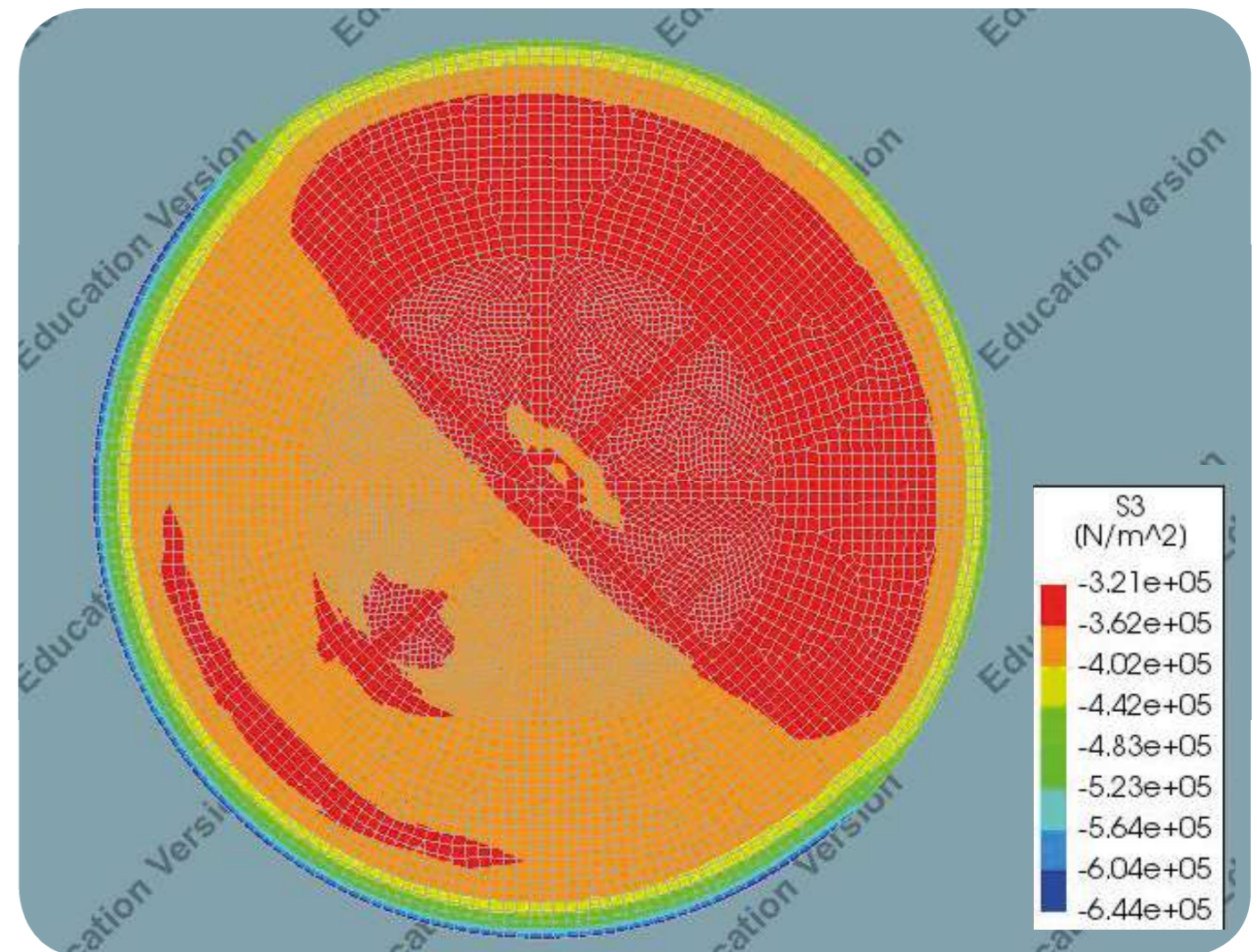



Principle stresses at base (N/m ²)		
	<i>LC 1 (Sym)</i>	<i>LC2 (Asym)</i>
<i>S2 (min)</i>	-8,86E+04	-7,98E+04
<i>S3 (max)</i>	-4,76E+05	-6,44E+05

$$6,44E^5 \text{ (SYSTEM) N/m}^2 \leq 61,6E^6 \text{ (TPU) N/m}^2$$

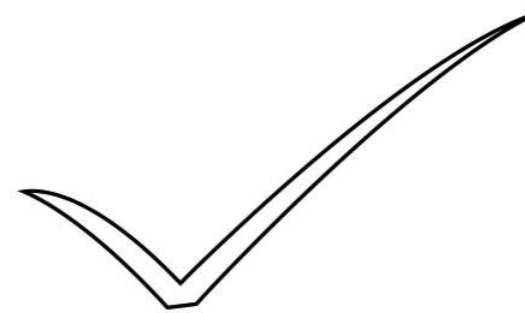

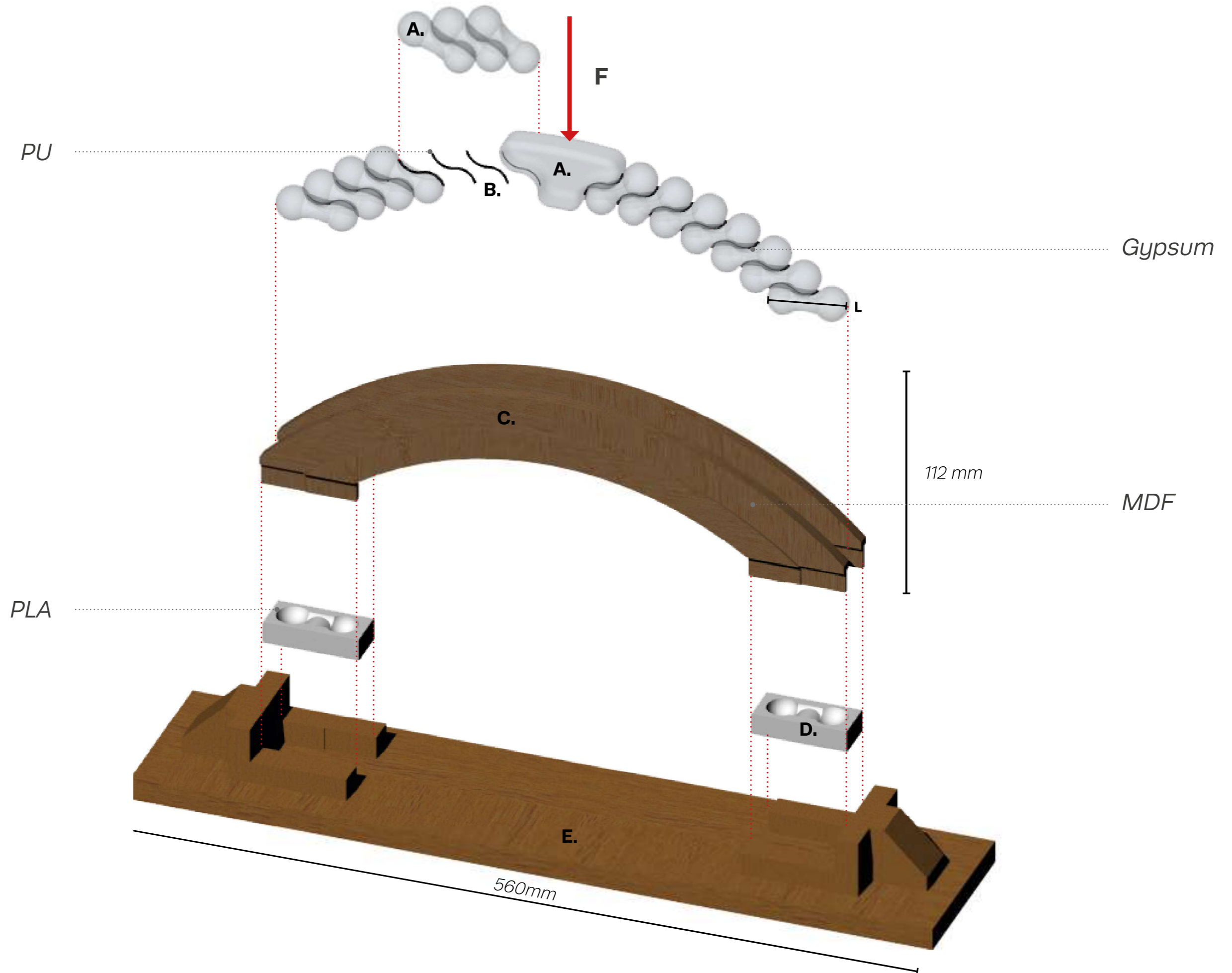
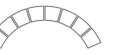

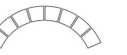

Start



REDUNDANT

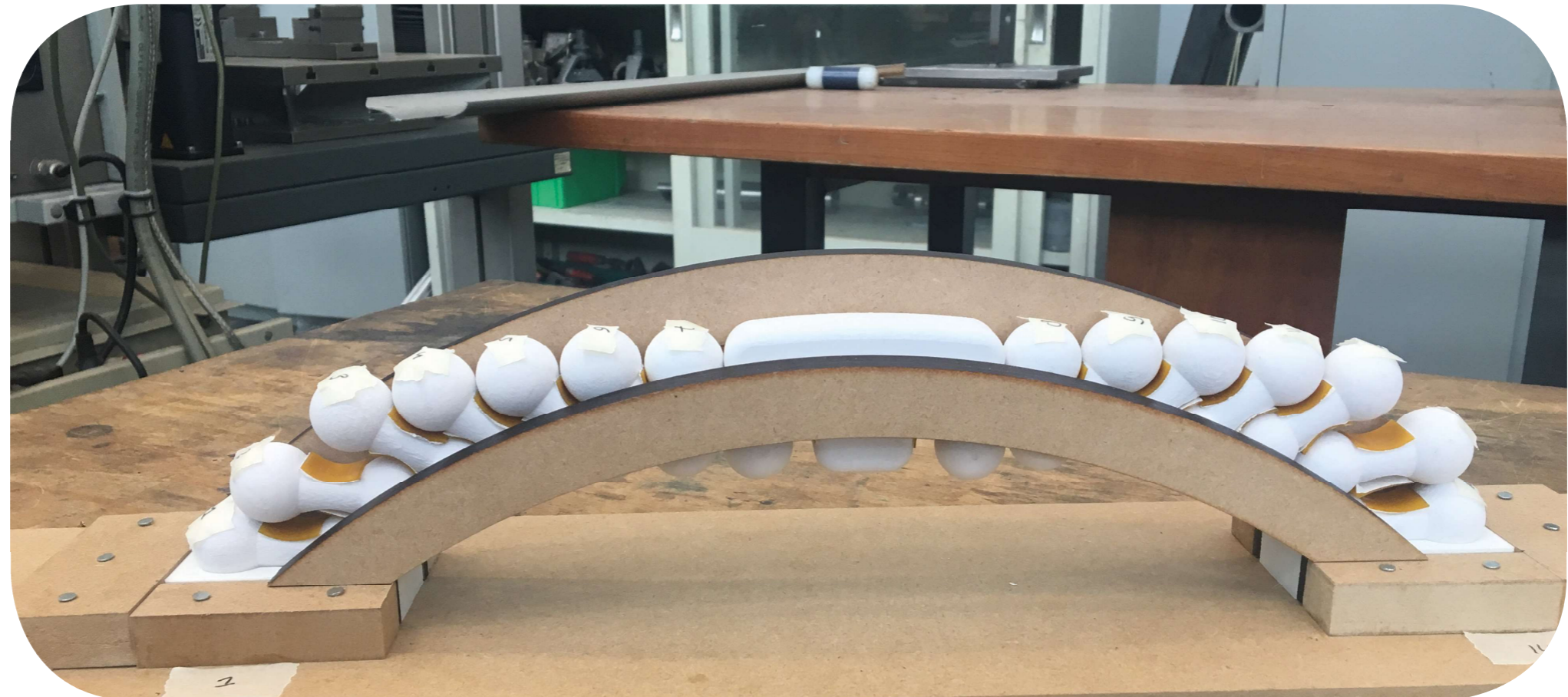

End

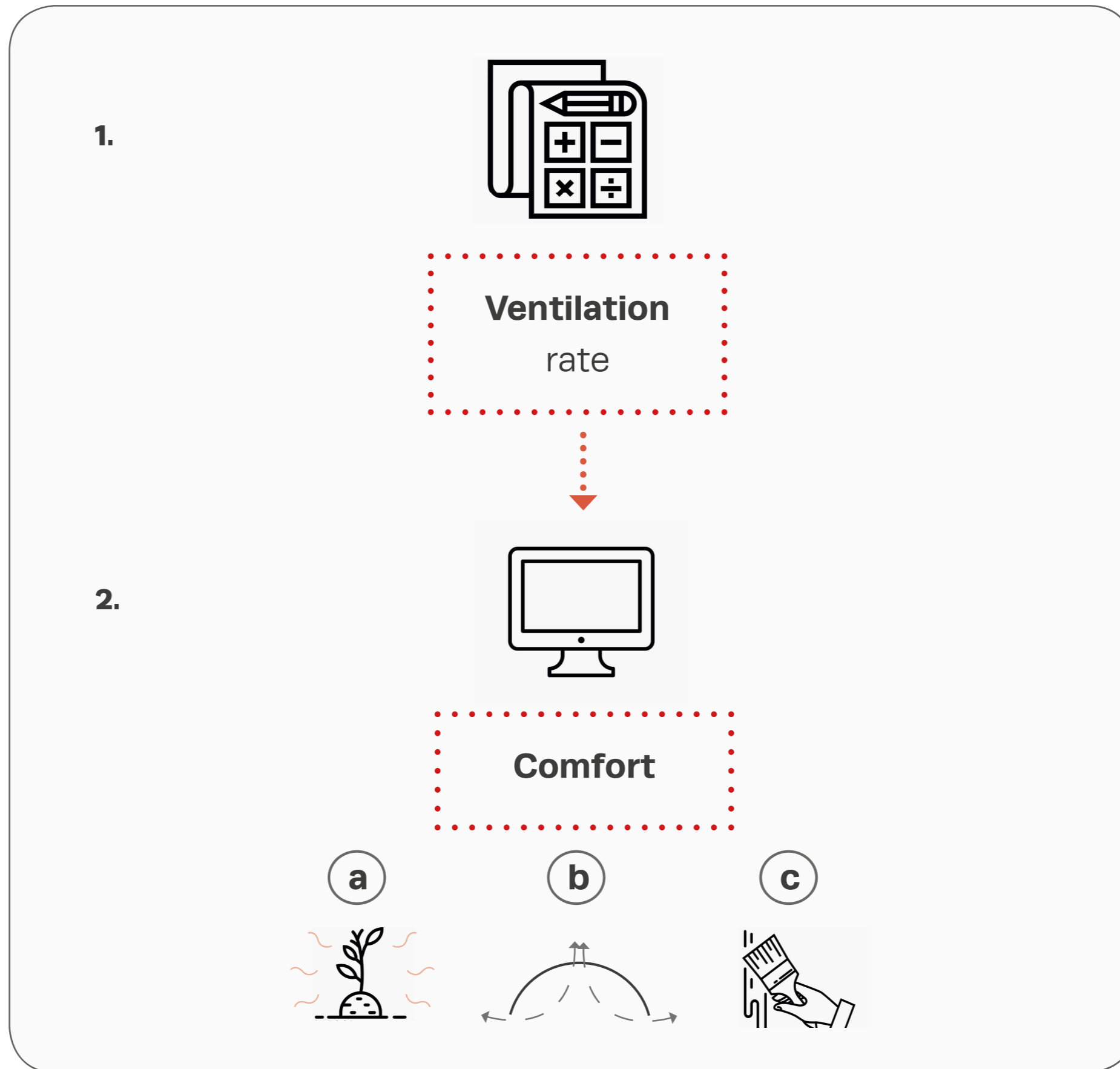

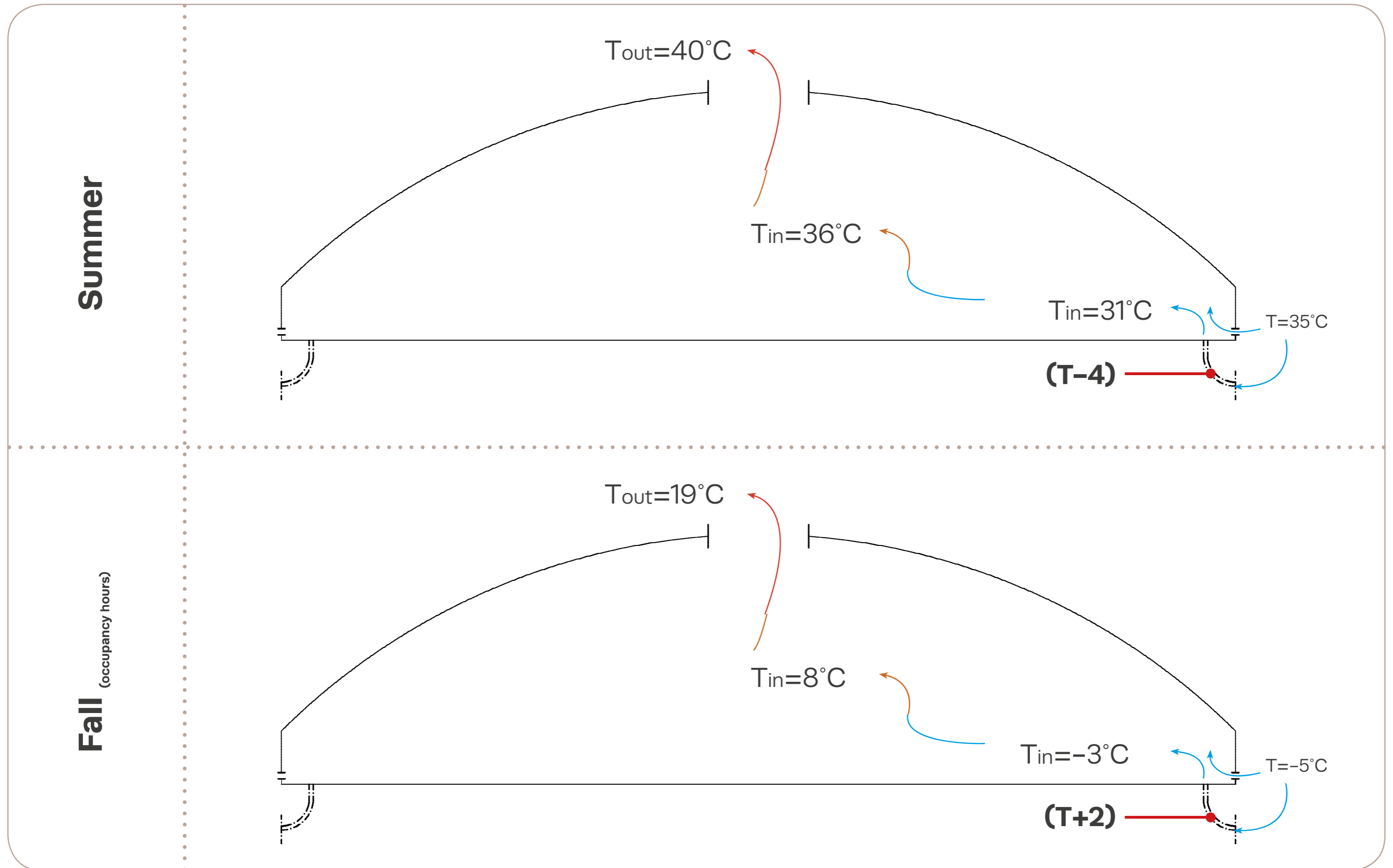



VENTILATION RATE:

$$n = Q/V = 100 * 35 \text{ (m}^3\text{/h)} / V = \mathbf{0,6h^{-1}} \ominus$$
$$v < 0,5 \text{ m/s}$$

slight breeze

$$v = 0,5 \text{ m/s} \quad n = \mathbf{2h^{-1}} \oplus$$

OPENINGS

$$A = \frac{n * V}{C_d * 3600} * \sqrt{\frac{p}{2\Delta p}} = m^2 \quad \mathbf{9,3m^2}$$

$$\Delta P = gh * (P/R) * (1/T_{out} - 1/T_{in}) = -0,21 \text{ Pa} \quad \Delta T = 0,6$$

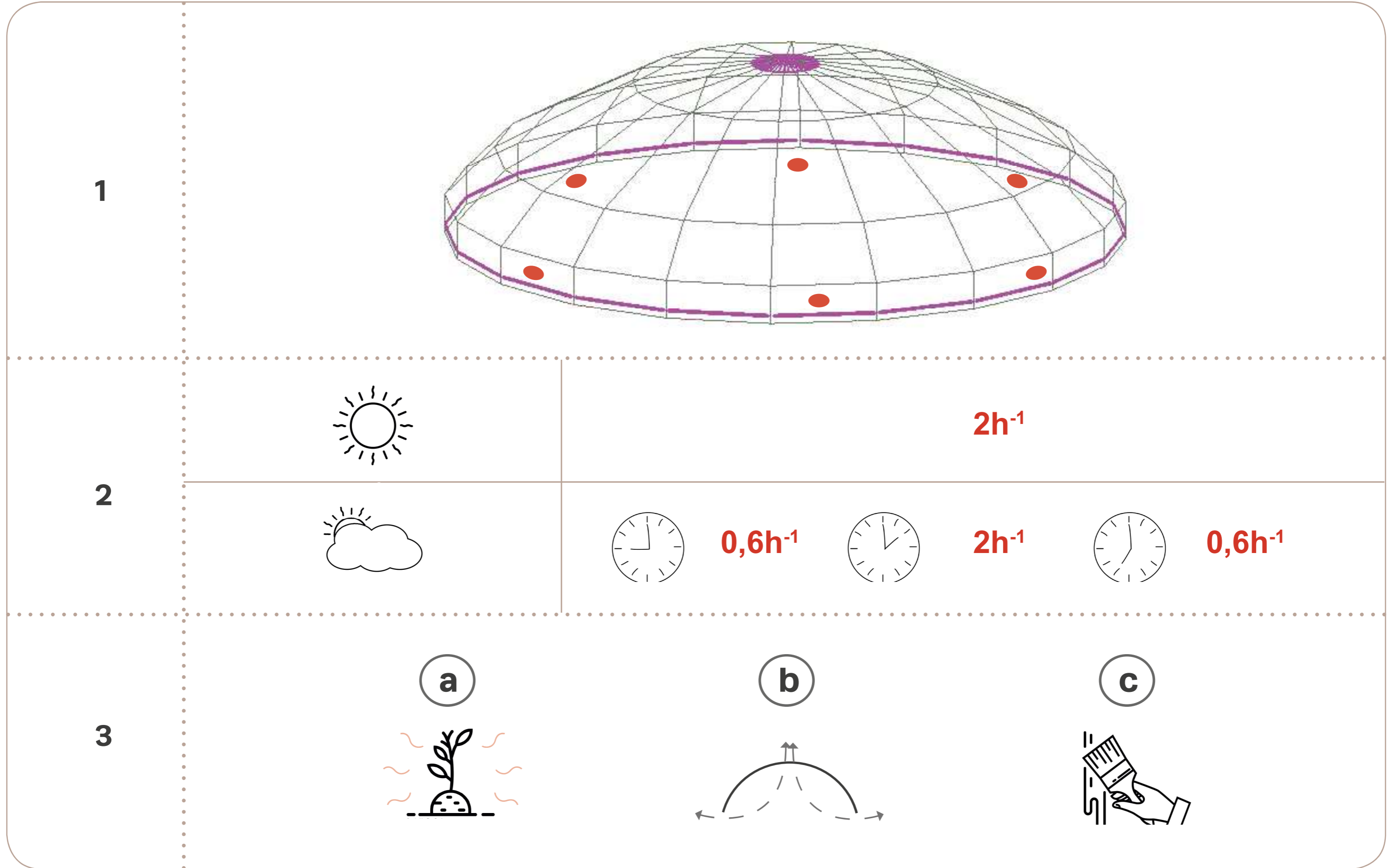

Thermal performance: Consequence of the passive strategies...

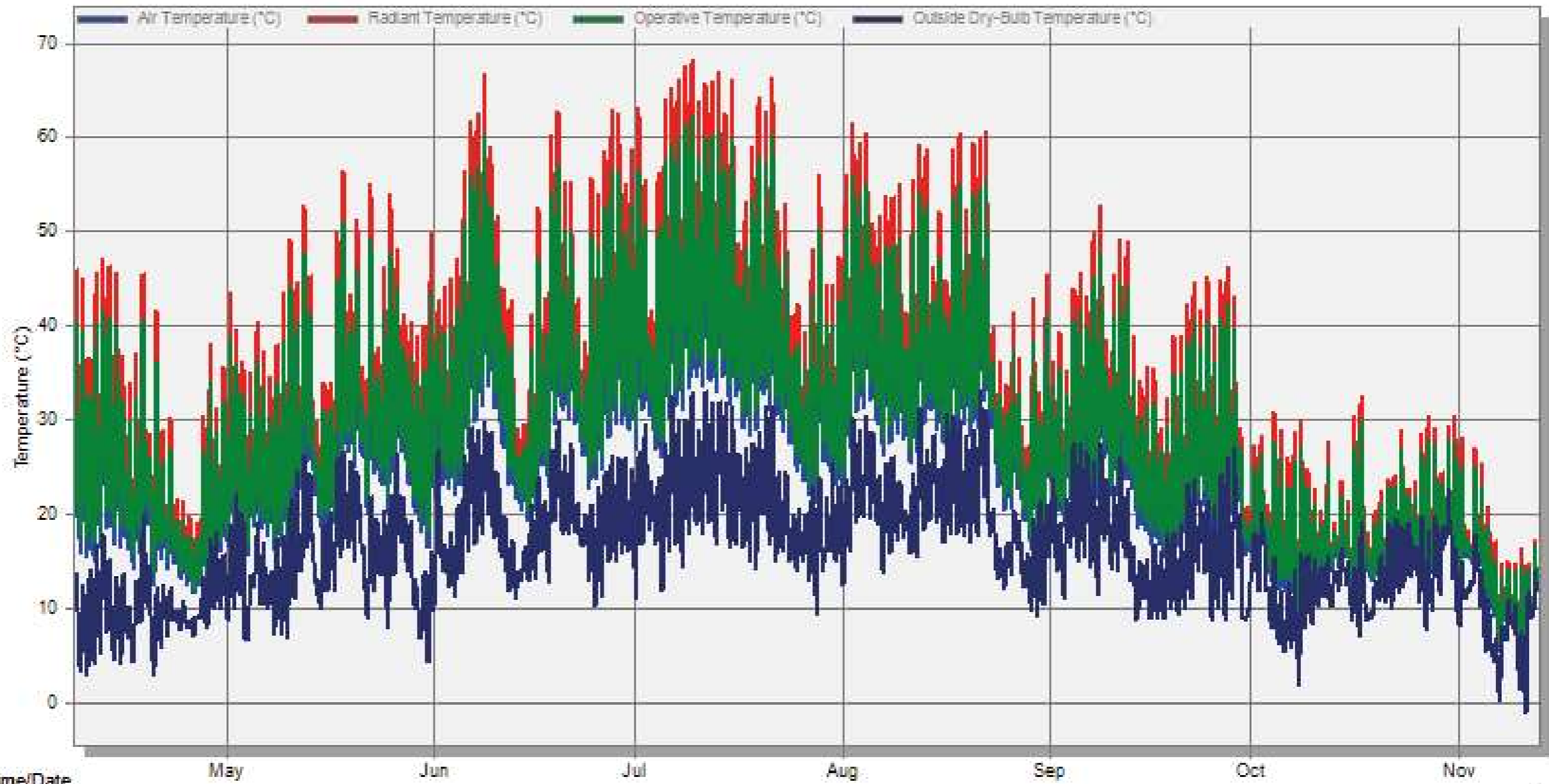

Time/Date	May	Jun	Jul	Aug	Sep	Oct	Nov			
Air Temperature (°C)	16,43	33,60	47,78	46,46	39,94	38,64	21,58	18,77	12,92	16,13
Radiant Temperature (°C)	18,14	36,25	54,35	57,76	46,83	47,43	26,27	22,80	14,45	17,05
Operative Temperature (°C)	17,29	34,92	51,07	52,11	43,39	43,03	23,93	20,78	13,69	16,59
Dry-Bulb Temperature (°C)	9,94	22,88	29,00	24,17	25,83	26,84	13,45	9,83	8,13	13,02

Thermal performance: Consequence of the passive strategies...

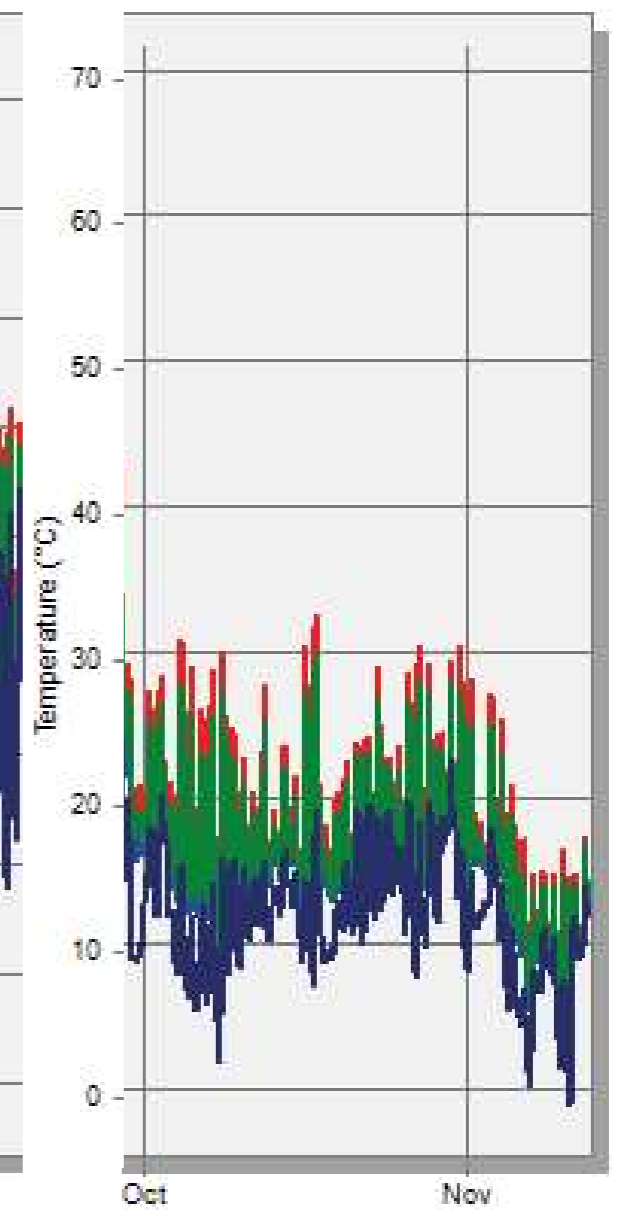
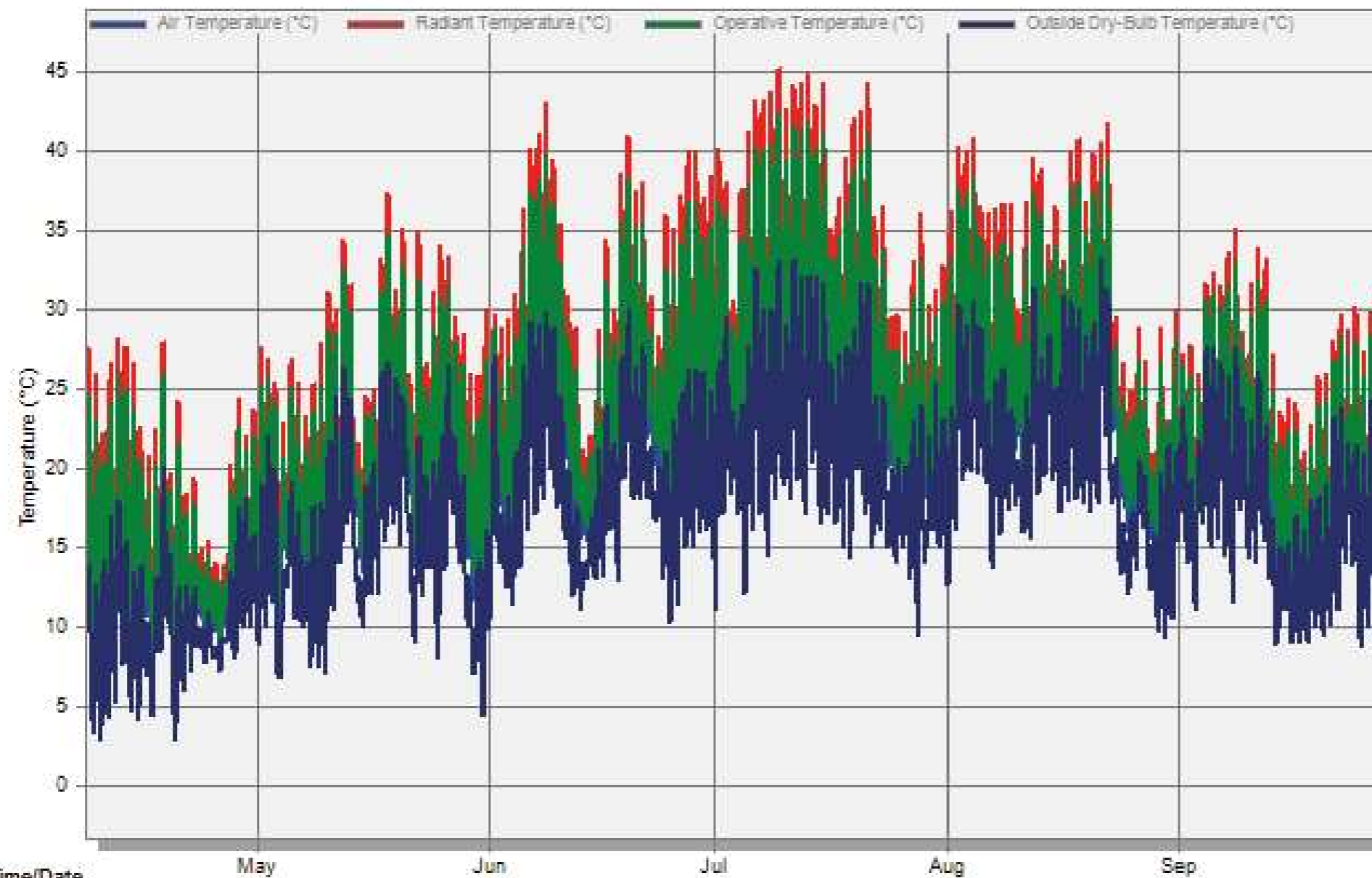

Time/Date	May	Jun	Jul	Aug	Sep
Air Temperature (°C)	11,73	24,95	32,98	31,13	30,63
Radiant Temperature (°C)	12,65	25,93	36,00	36,65	34,33
Operative Temperature (°C)	12,19	25,44	34,49	33,89	32,46
Dry-Bulb Temperature (°C)	9,94	22,88	29,00	24,17	25,83

Time/Date	Oct	Nov
Air Temperature (°C)	12,92	16,13
Radiant Temperature (°C)	14,45	17,05
Operative Temperature (°C)	13,69	16,59
Dry-Bulb Temperature (°C)	8,13	13,02



6th of July



Thermal performance: Conclusion passive strategies....

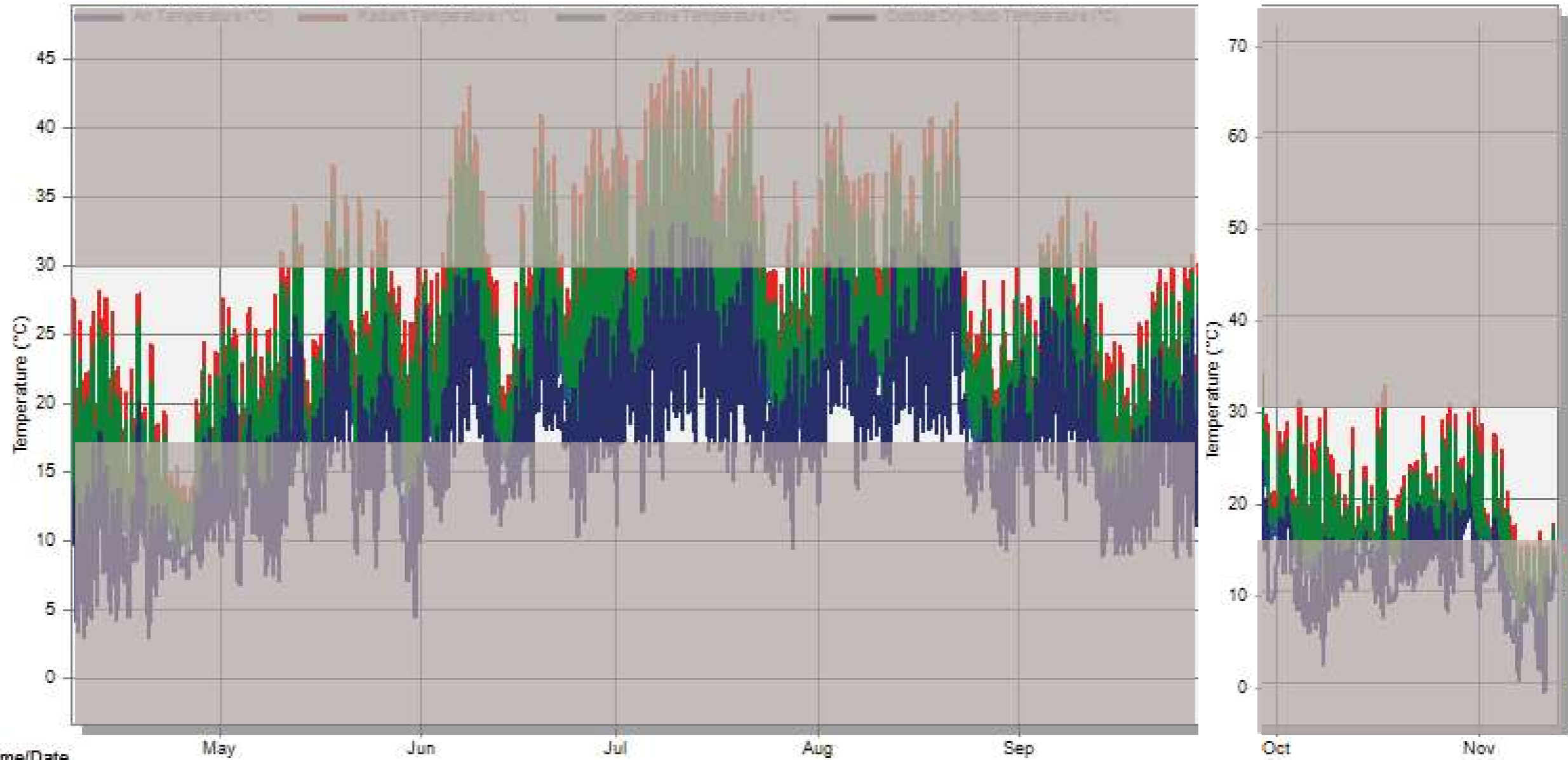

Time/Date	May	Jun	Jul	Aug	Sep	Oct	Nov	
Air Temperature (°C)	11,73	24,95	32,98	31,13	30,63	30,58	17,48	14,03
Radiant Temperature (°C)	12,65	25,93	36,00	36,65	33,68	34,33	20,15	16,82
Operative Temperature (°C)	12,19	25,44	34,49	33,89	32,16	32,46	18,81	15,43
Outside Dry-Bulb Temperature (°C)	9,94	22,88	29,00	24,17	25,83	26,84	13,45	9,83

19/18°C > T > 30°C

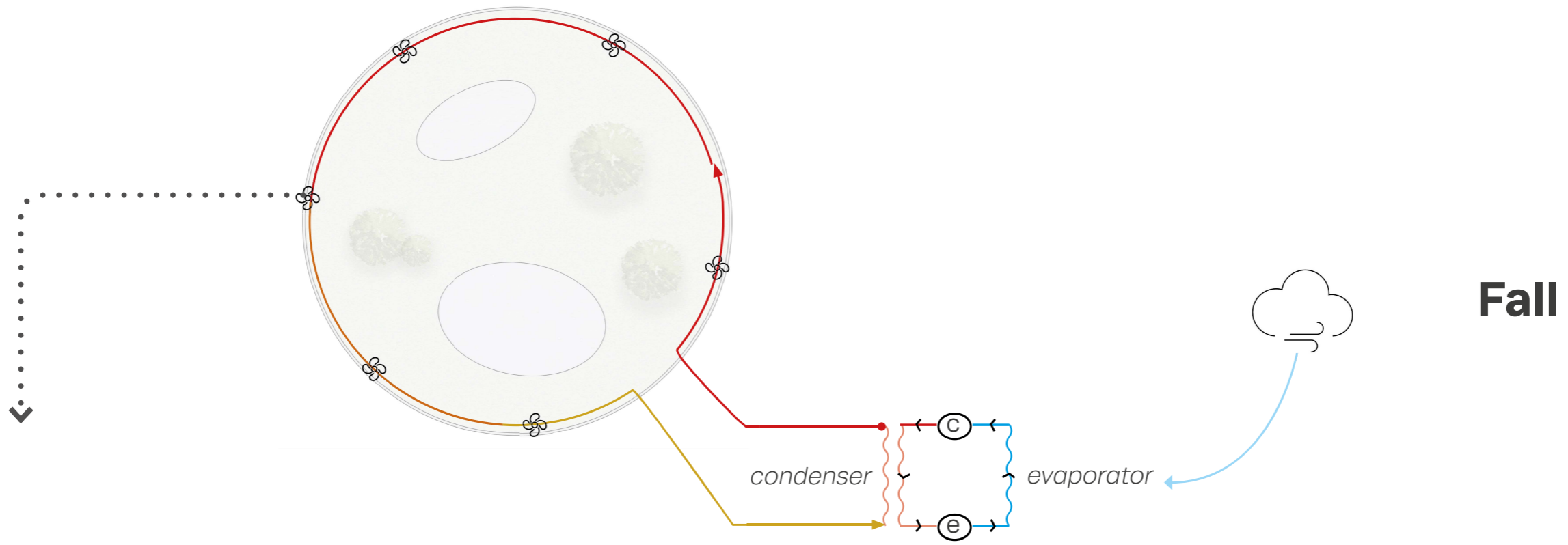

Fan coils

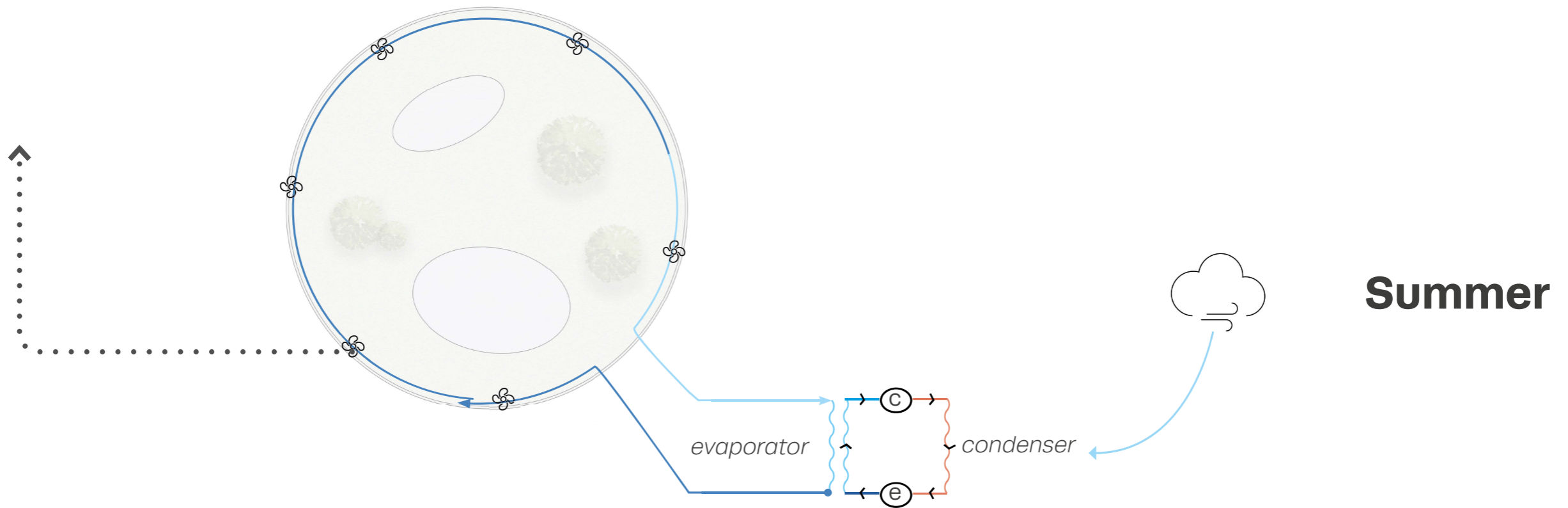

Thermal performance: Final result...

SUMMER

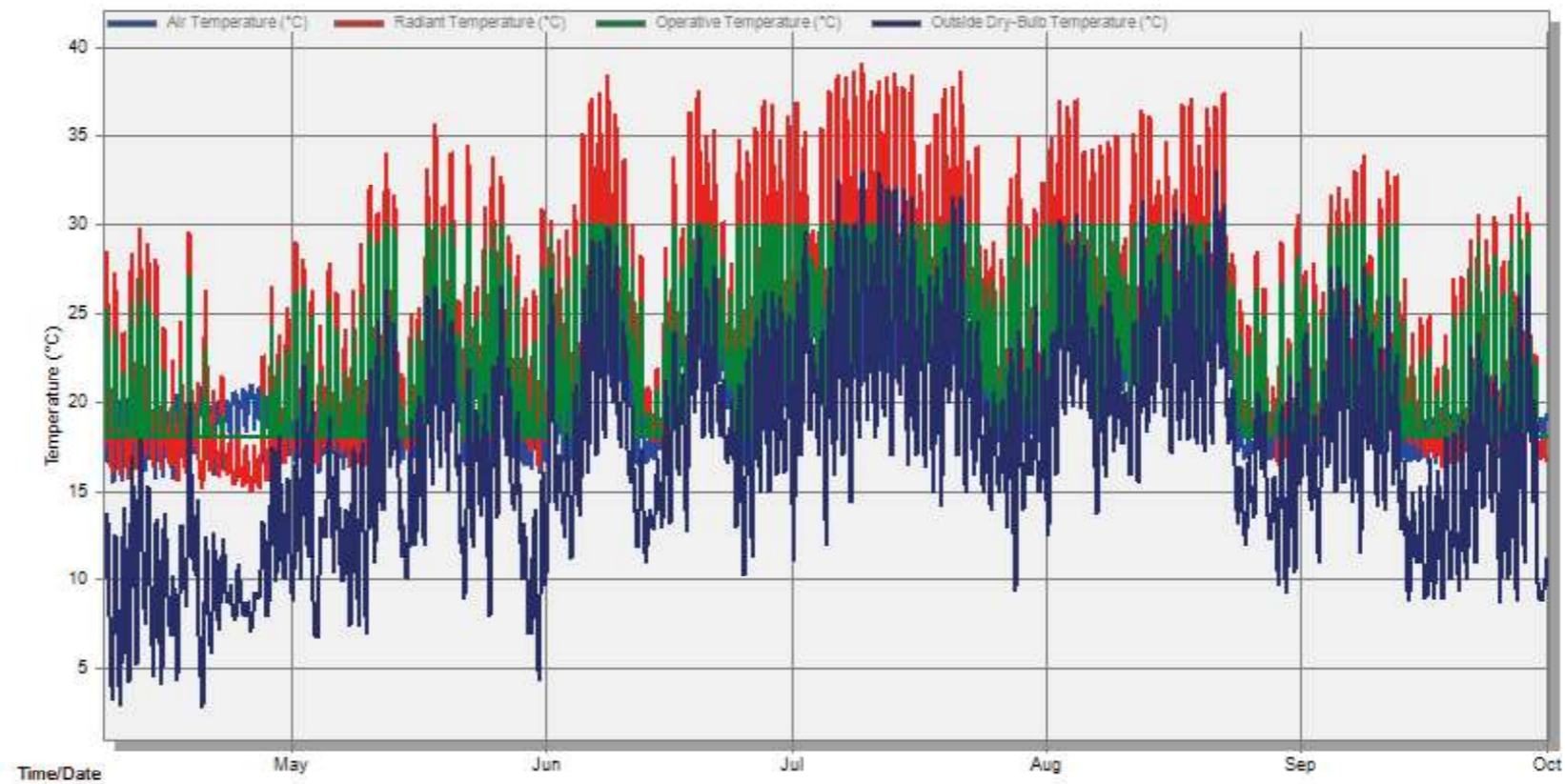

1 Oct - 12 Nov, Hourly

Evaluation

FALL

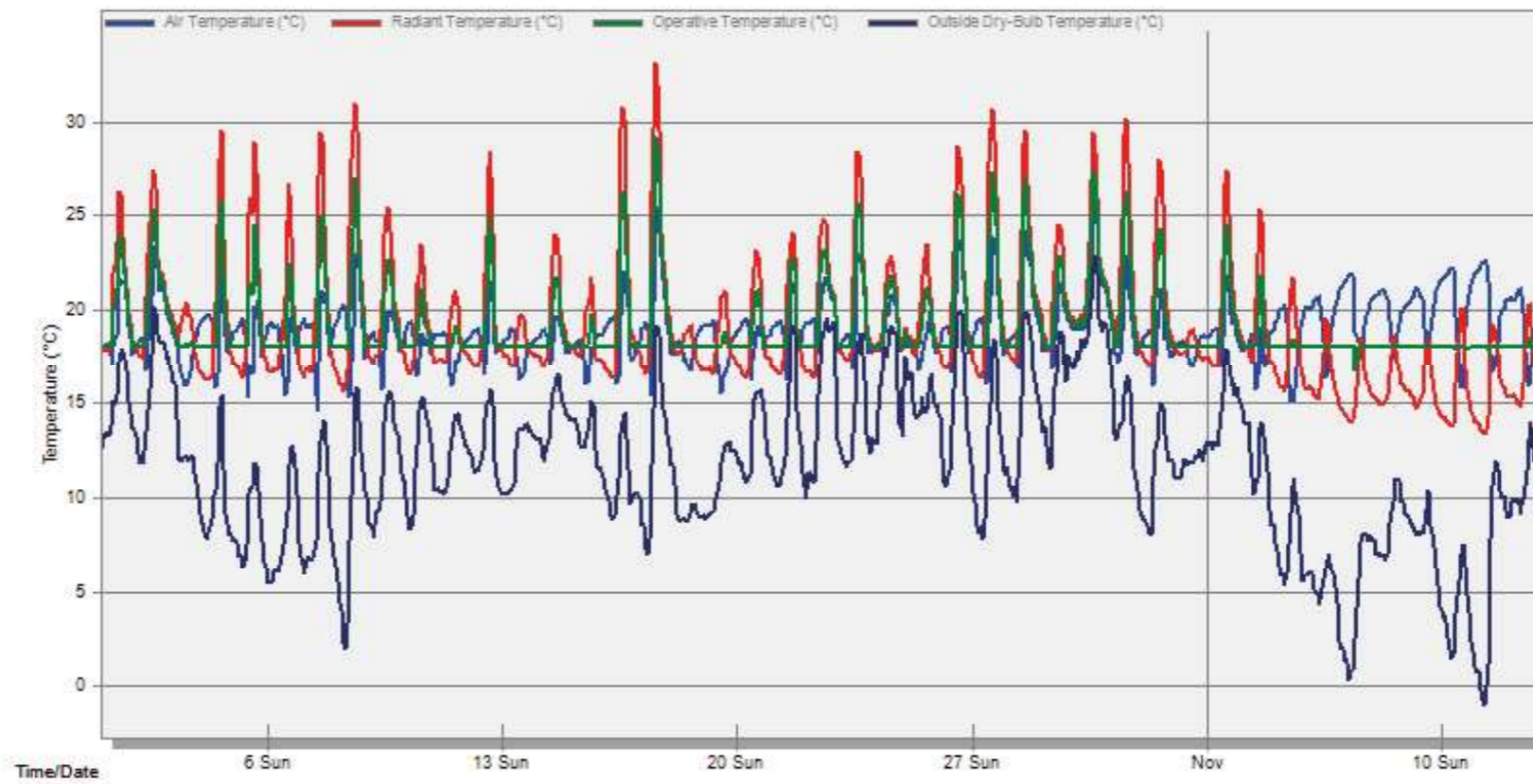

passive systems (61%) & active system (39%)

5. Evaluation

Conclusions | Recommendations

“How can a solely glass dome be developed and assembled from structural cast glass components while providing thermal comfort and being minimum invasive for the local environment?”.



1ST: OMNIDIRECTIONAL CAST GLASS COMPONENTS

2nd: PASSIVE STRATEGIES

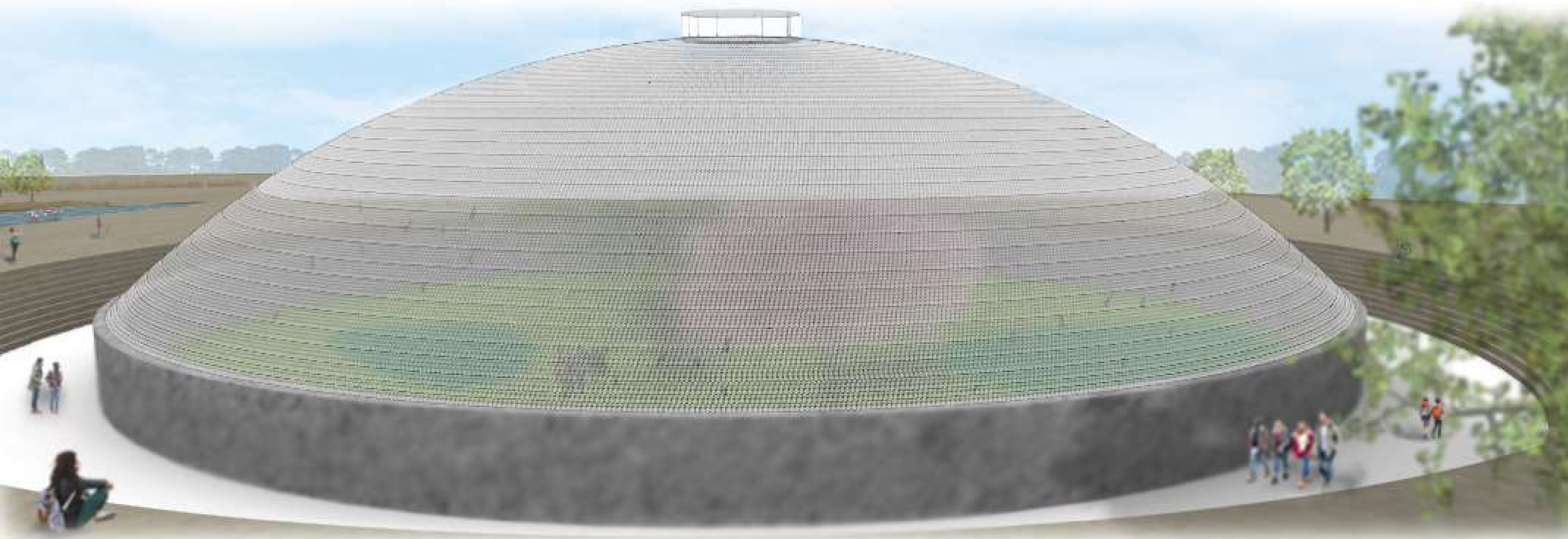

2nd: PASSIVE STRATEGIES

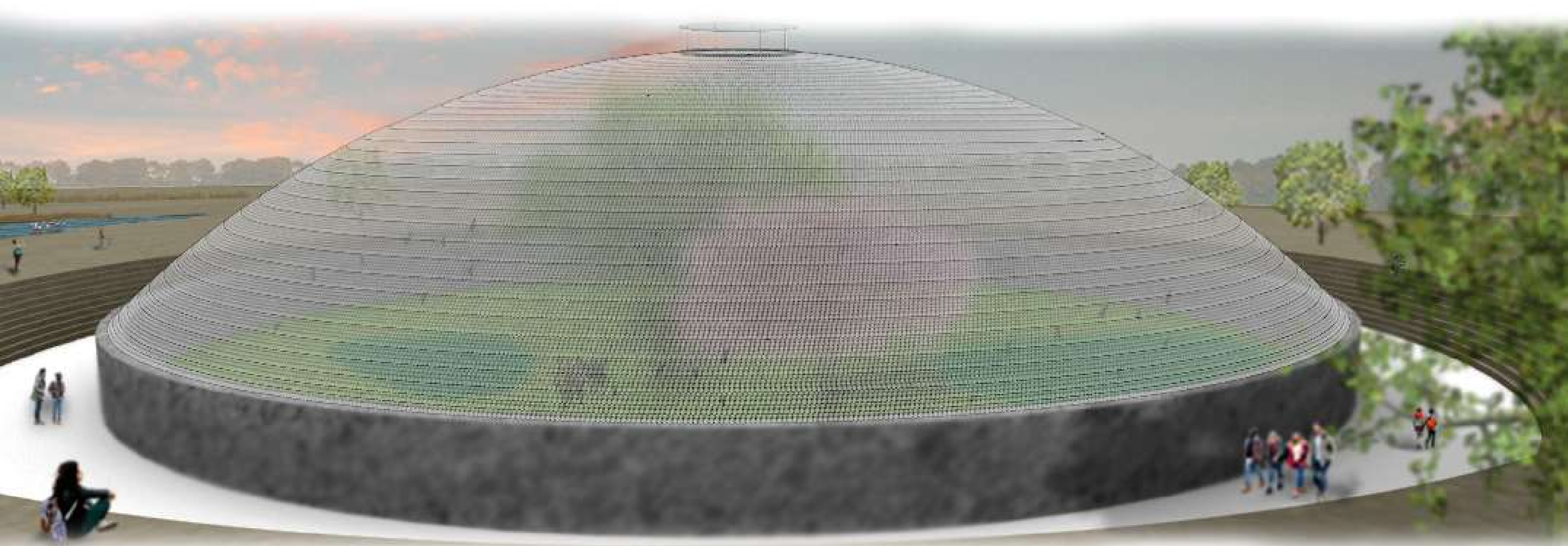

The image shows a close-up of six white, spherical pills arranged in two rows of three within a blister pack. The pills have a slightly textured surface. A red, curved callout banner is positioned across the middle of the pack, pointing to the edges of the pills. The text 'SHARP EDGES' is written in bold, black, uppercase letters on this banner.

SHARP EDGES

Evaluation: *Stiffness of the entire system...*

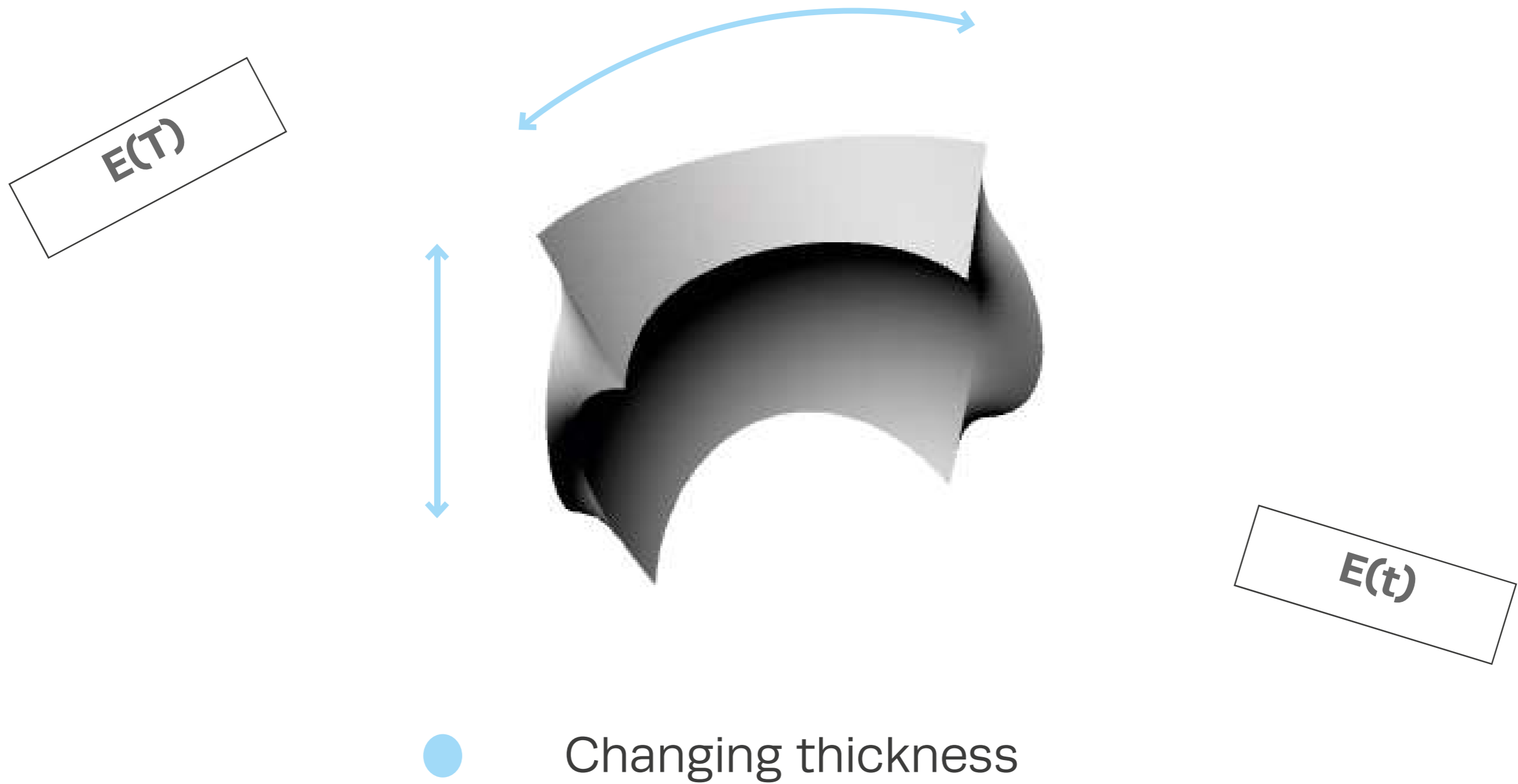

HEATING TUBE

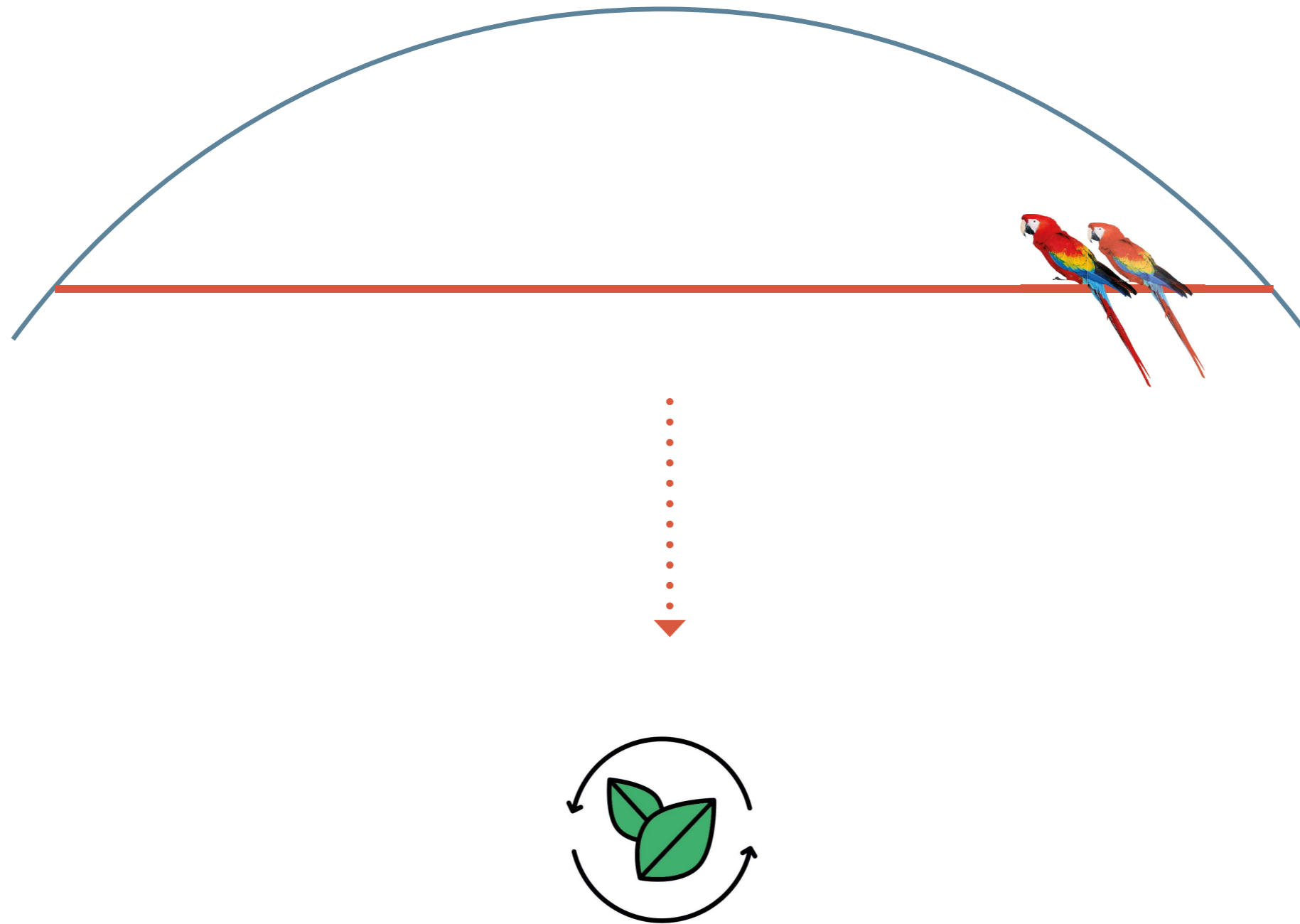

REAL PHYSICAL EXPERIMENTS

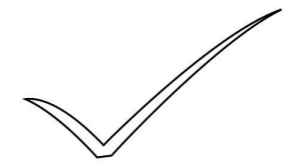



“Architecture is measured against the past, you build in the present, and try to imagine the future”

(Richard Rogers)

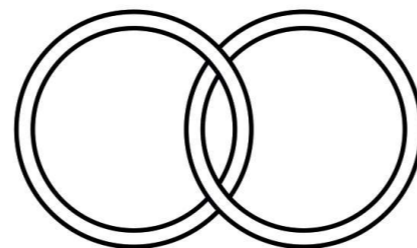

THANK YOU 