

WAYFINDING IN THE EVER-CHANGING SHOPPING MALL

Lijnbaan

P5 Presentation MSc4
Adapting 20th Century Heritage

Vinny van Buren
4844637

22-06-2023

INTRODUCTION

De Lijnbaan / Rotterdam

INTRODUCTION



INTRODUCTION



INTRODUCTION

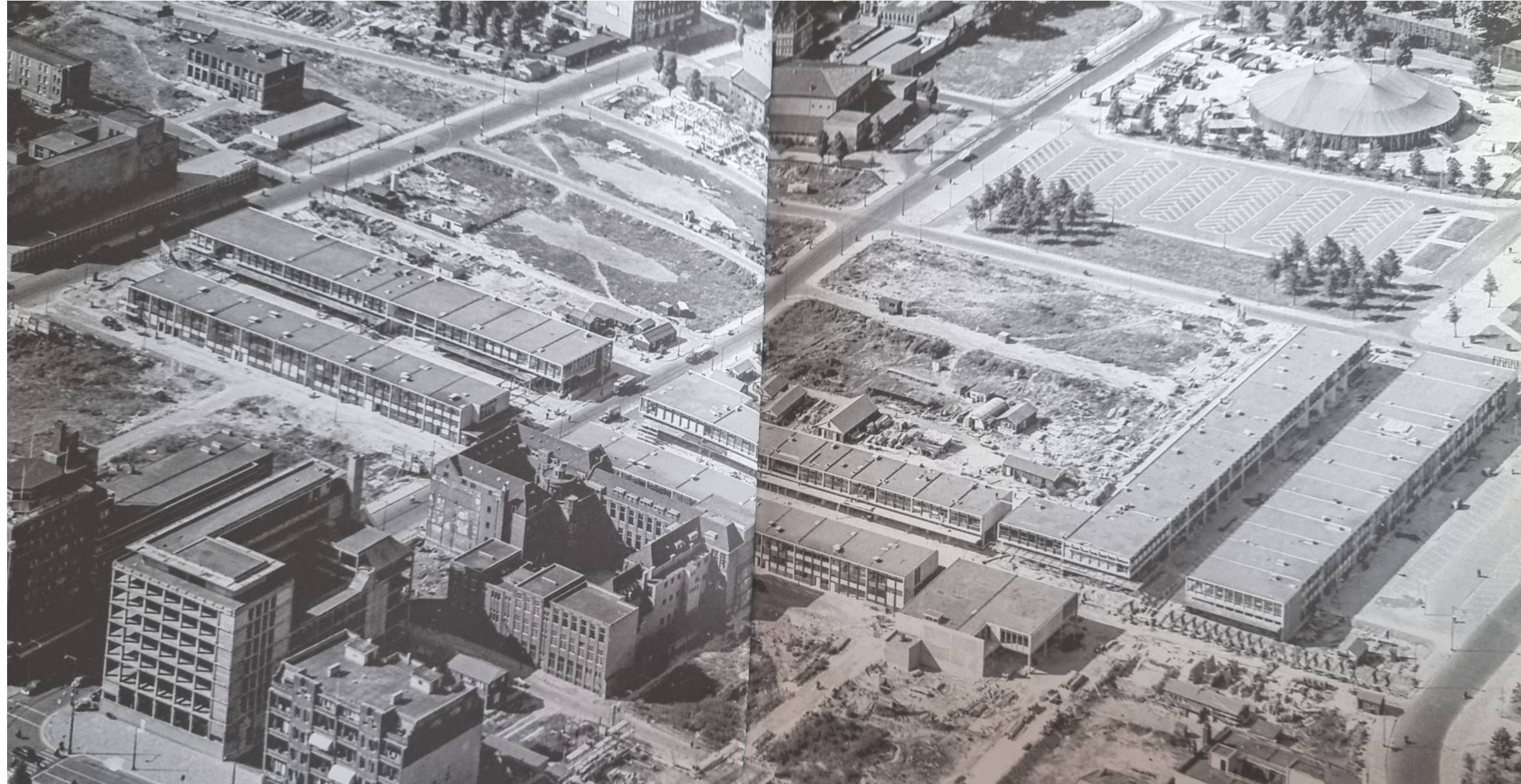

INTRODUCTION



INTRODUCTION



INTRODUCTION

"...the original quality and 1950s appearance were restored to approximately 800 linear metres of Lijnbaan's facades. With this, De Lijnbaan has been restored to its former glory..."

- Mei Architects



INTRODUCTION



INTRODUCTION



INTRODUCTION

Research & Design

RESEARCH

The influence of architectural interventions on the visitors' experience

INTRODUCTION

Research & Design

RESEARCH

The influence of architectural interventions on the visitors' experience

DESIGN

Using that knowledge to improve upon 'neglected' parts of the Lijnbaan

RESEARCH

RESEARCH

Goal

Existing literature:

FIG. 14. *The visual form of Los Angeles as seen in the field*

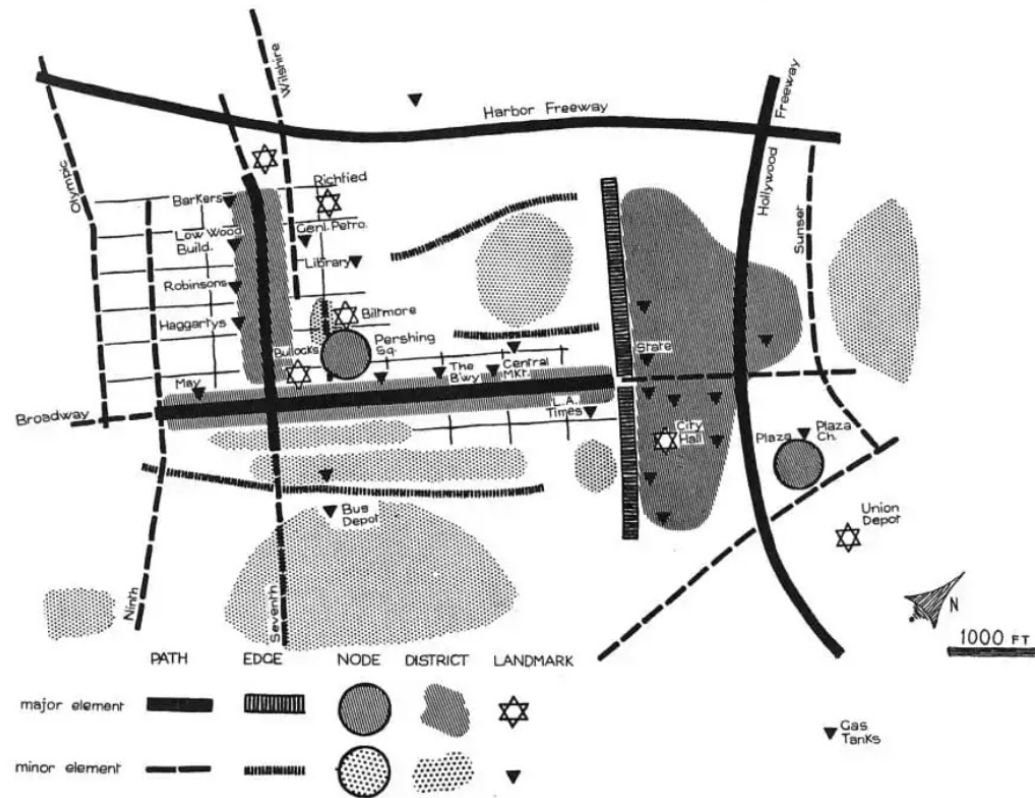

URBAN SCALE

HUMAN SCALE

RESEARCH

Goal

Existing literature:

FIG. 14. *The visual form of Los Angeles as seen in the field*

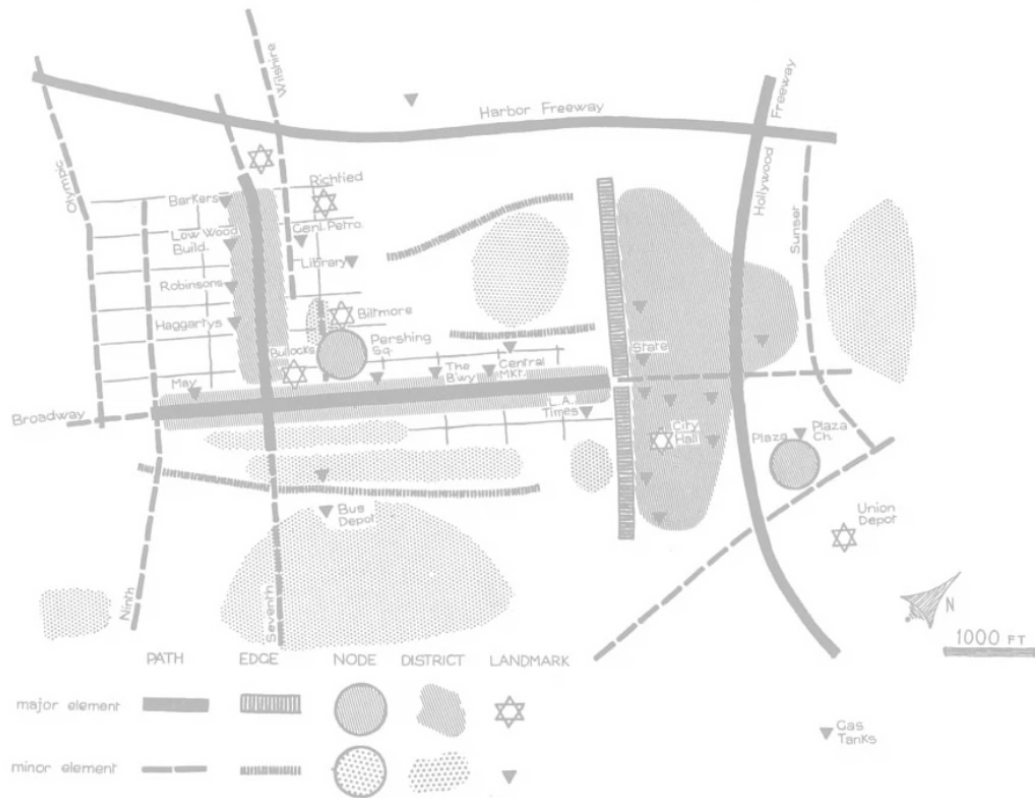

URBAN SCALE

BUILDING SCALE

HUMAN SCALE

RESEARCH

Goal

Existing literature:

Applying theory on a Dutch post-war shopping mall, The Lijnbaan

More complete understanding of mall visitor experiences

Use for intervention decision making in design



BUILDING SCALE

HUMAN SCALE

RESEARCH

Research Questions & Methodology

How do interventions in the spatial composition influence the way visitors navigate a Dutch post-war shopping mall?

RESEARCH

Wayfinding in Malls

- ***The Image Of The City*** - Kevin Lynch, 1960

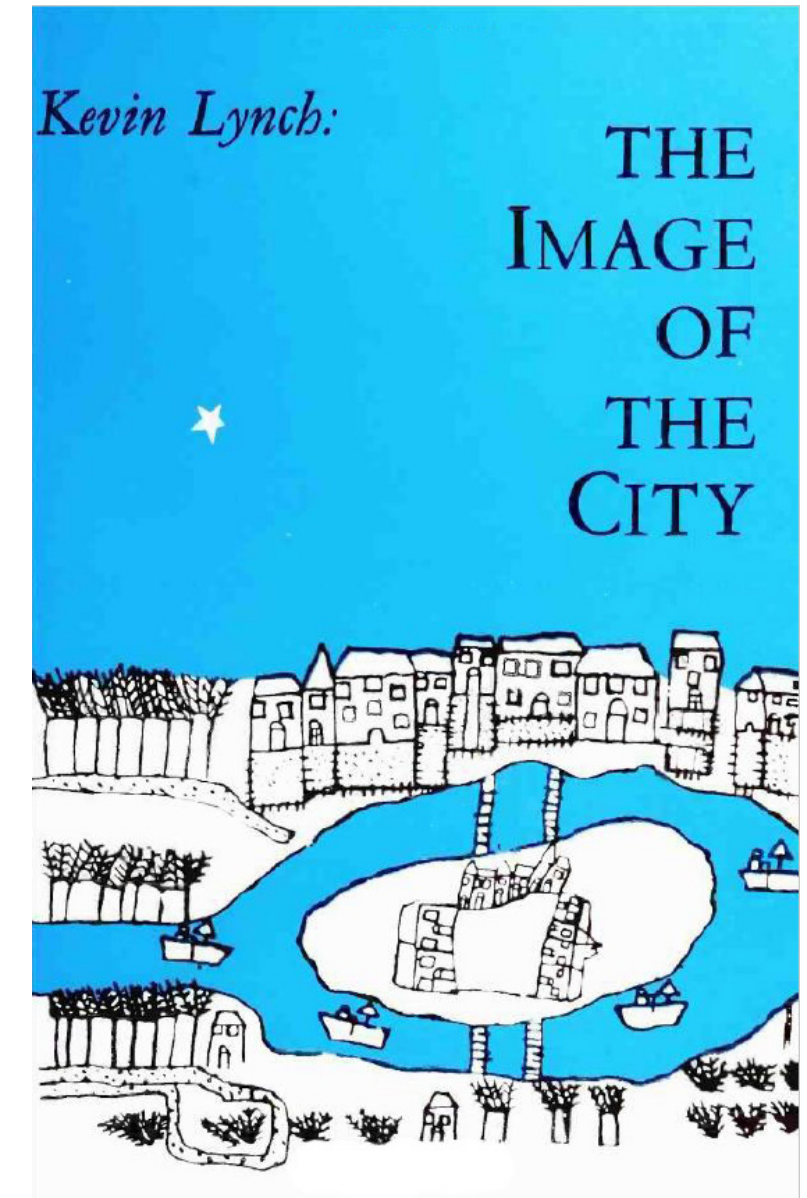

RESEARCH

Wayfinding in Malls

- *The Image Of The City* - Kevin Lynch, 1960
- **Wayfinding: People, Signs and Architecture**
Paul Arthur & Romedi Passini, 1992
 - Form
 - Visibility, Access
 - Use
 - Symbolism

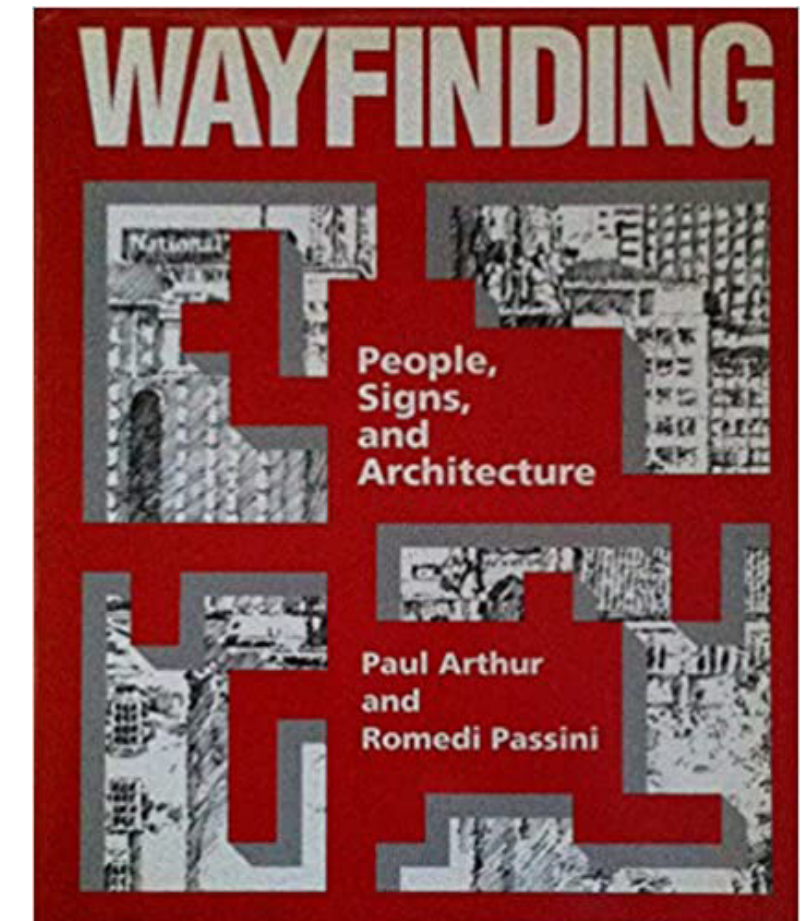
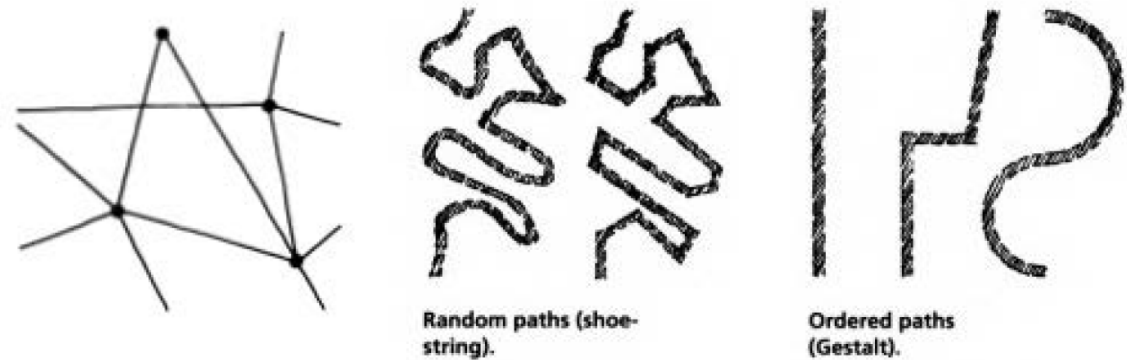

RESEARCH

Wayfinding in Malls

- *The Image Of The City* - Kevin Lynch, 1960
- *Wayfinding: People, Signs and Architecture*
Paul Arthur & Romedi Passini, 1992

- Form
- Visibility, Access
- Use
- Symbolism

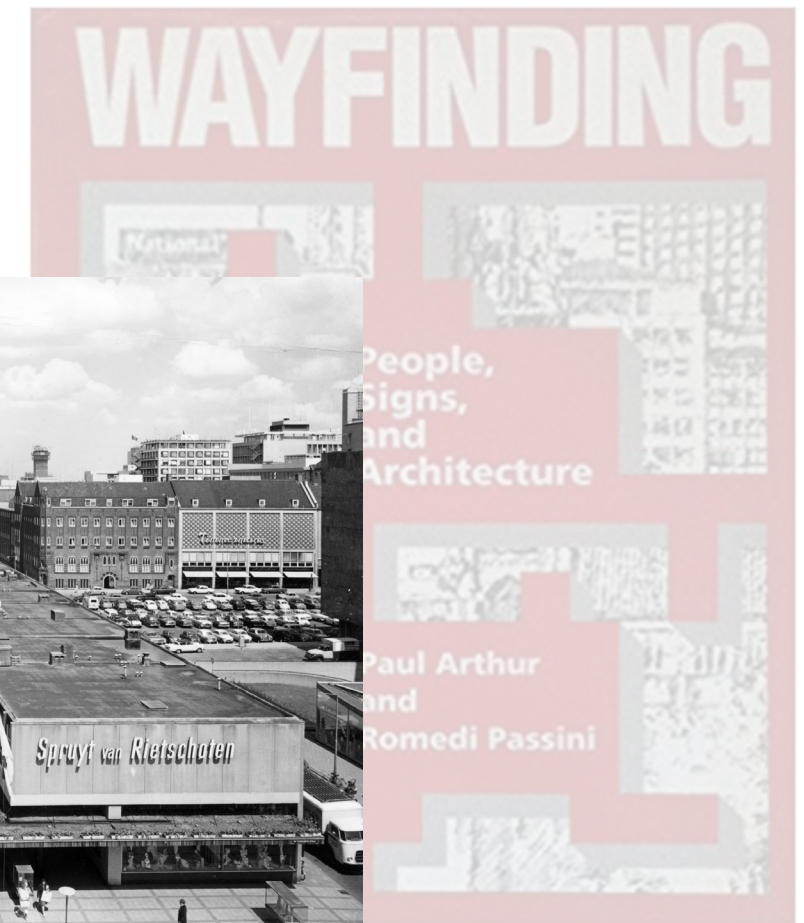

RESEARCH

Interventions

Re-Arch

+

Reduce, Reuse, Recycle

1+1=2

1+1=1

FACE-LIFT

SUBTRACTION

Adding a new, contrasting volume next to the existing

Adding a new volume that merges with the existing

Improving the façade with design, as well as the installations

Removing, downsizing, dismantling of a volume

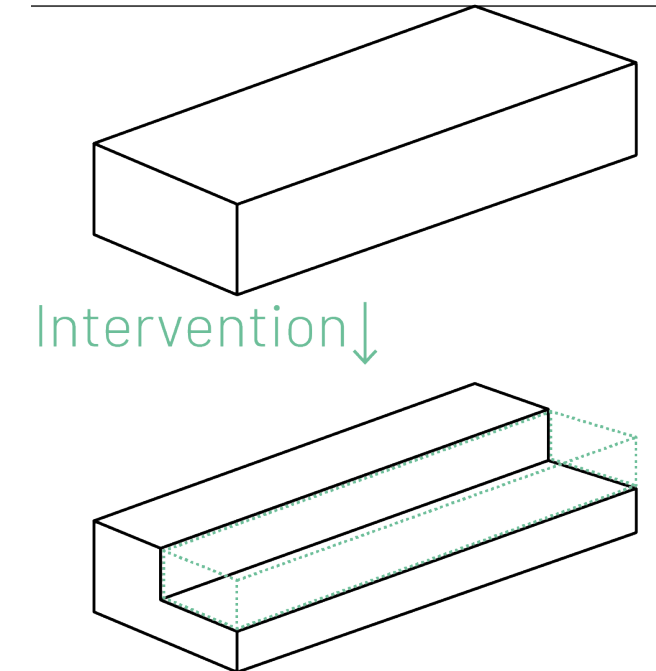
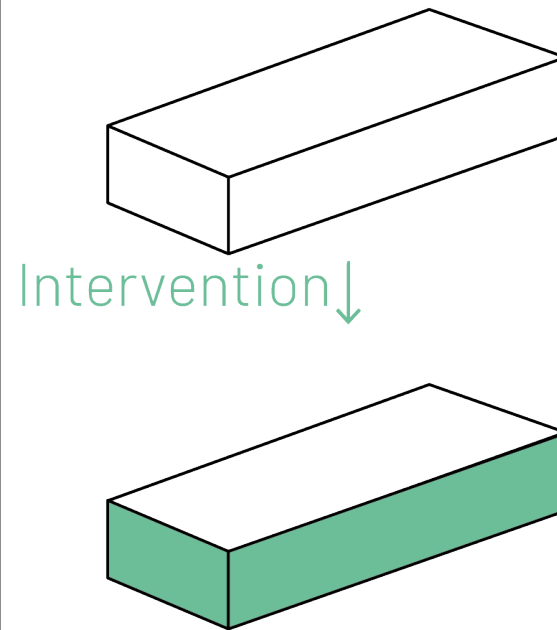
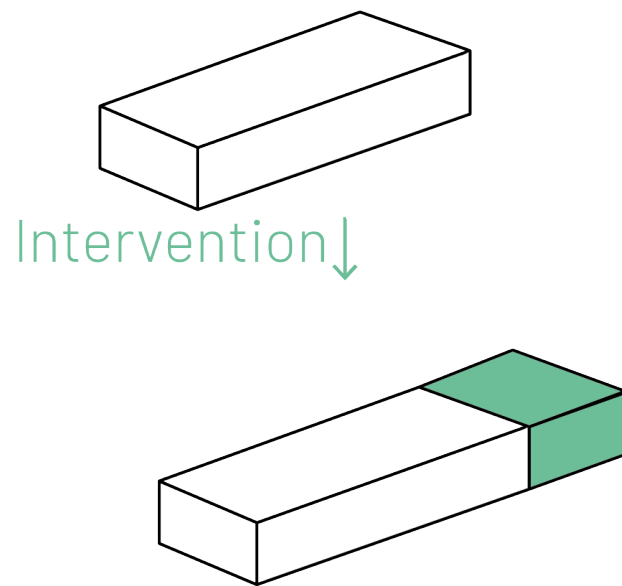
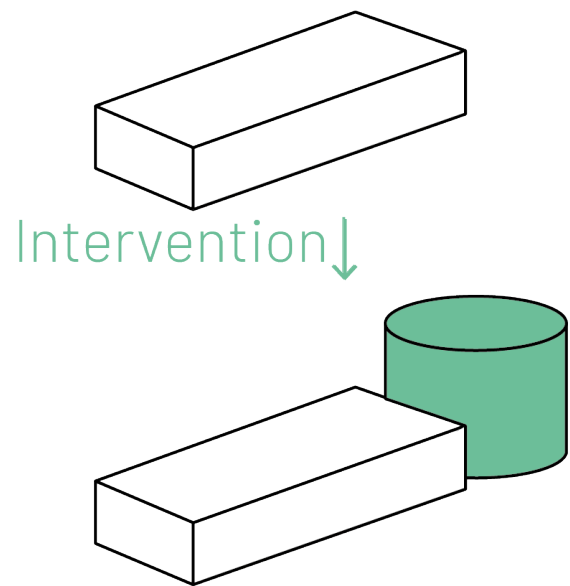

RESEARCH

Interventions, Lijnbaanplein



1971



2022



RESEARCH

Interventions, Lijnbaanplein

SUBTRACTION

Removing,
downsizing,
dismantling of a
volume

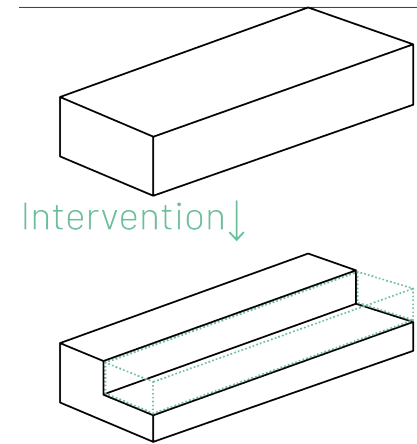

1971



2022



RESEARCH

Interventions, Lijnbaanplein

FACE-LIFT

Improving the façade with design, as well as the installations

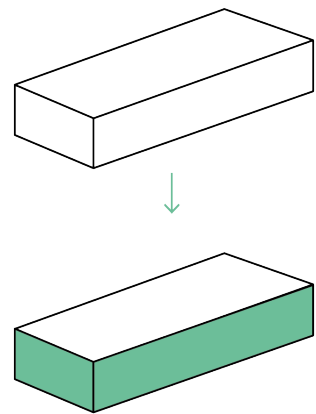

RESEARCH

Interview results



1971



2022

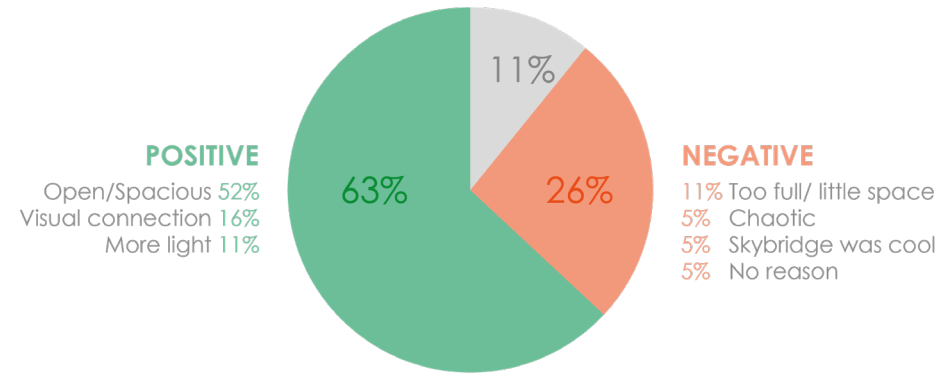

SKYBRIDGE REMOVAL
(n=19)

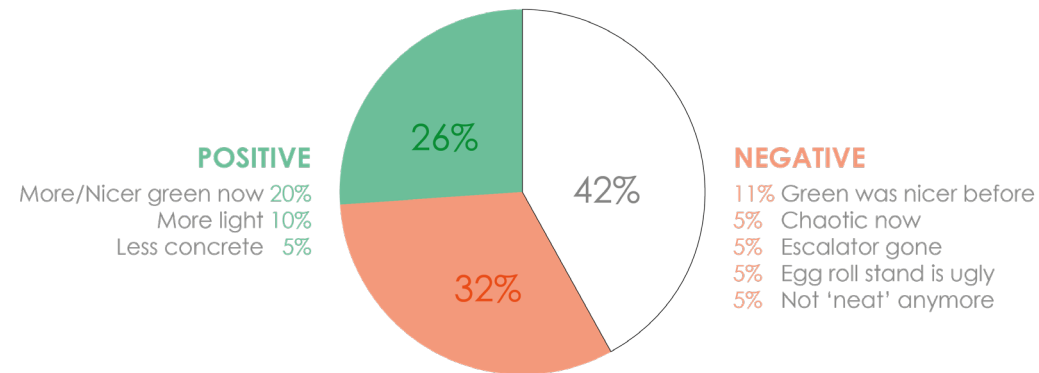

SQUARE ORGANISATION
(n=19)

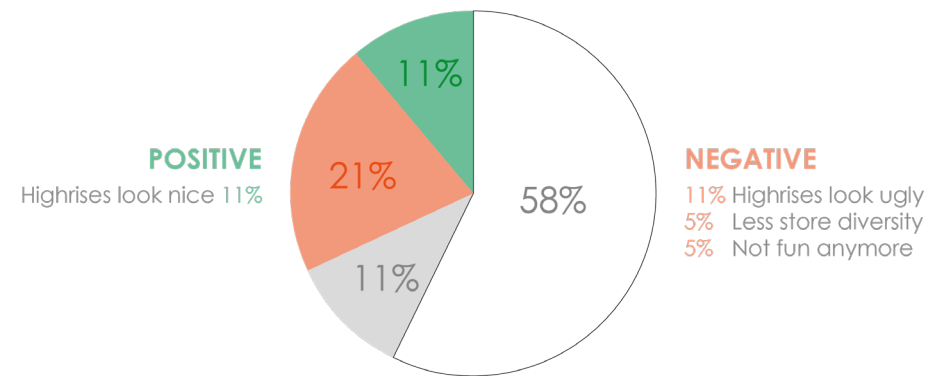

CONTEXT (OTHER FACTORS)
(n=19)

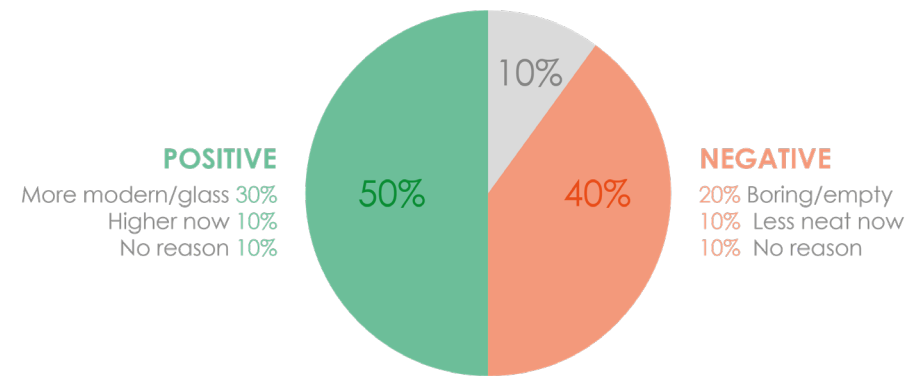

NEW FAÇADES FORUM
(n=10)

- Positive opinion on new
- Negative opinion on new
- Indifferent
- Topic not mentioned

RESEARCH

Interview results



1971



2022

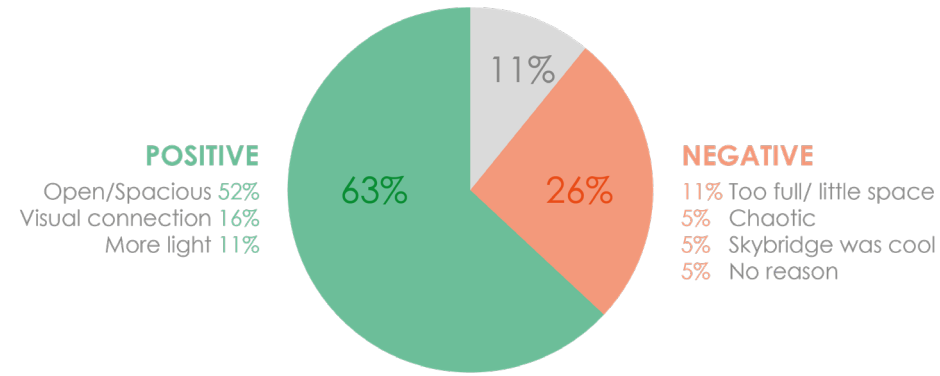

SKYBRIDGE REMOVAL
(n=19)

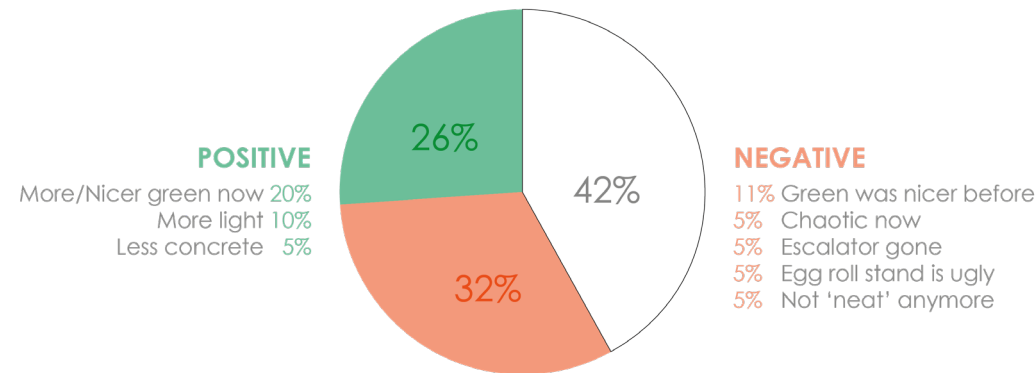

SQUARE ORGANISATION
(n=19)

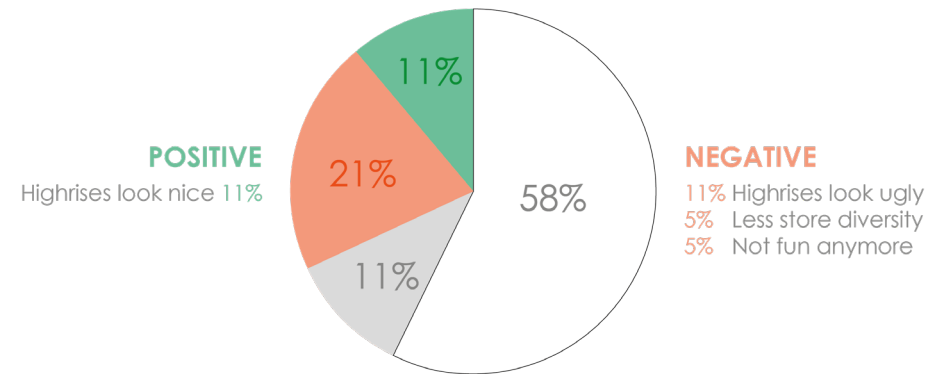

CONTEXT (OTHER FACTORS)
(n=19)

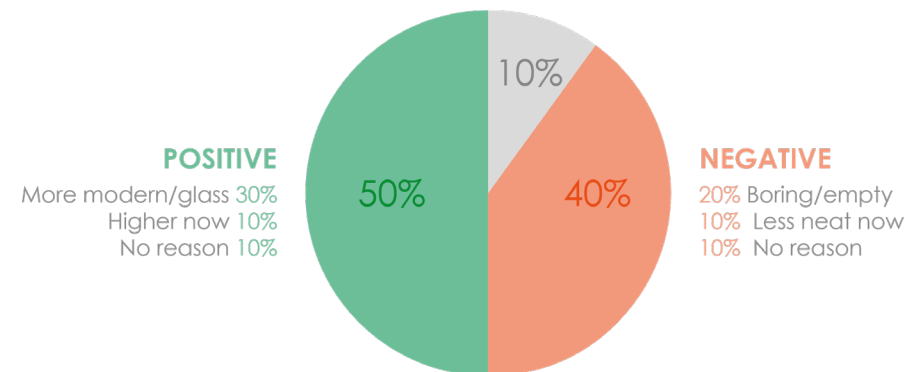

NEW FAÇADES FORUM
(n=10)

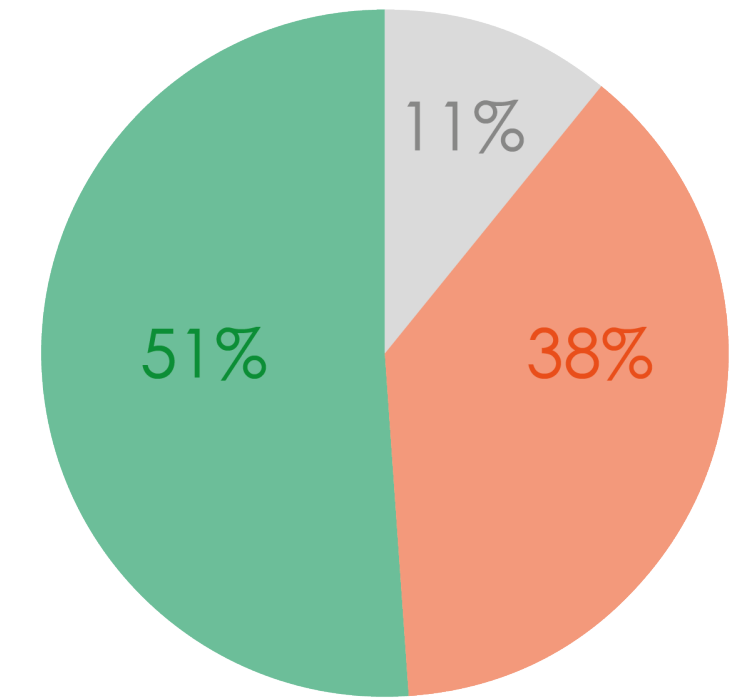

OLD HOSPITAL SQUARE
(n=19, 37 comments)

- Positive opinion on new
- Negative opinion on new
- Indifferent
- Topic not mentioned

RESEARCH

Interview results



1953



2022

RESEARCH

Interview results



1953



2022

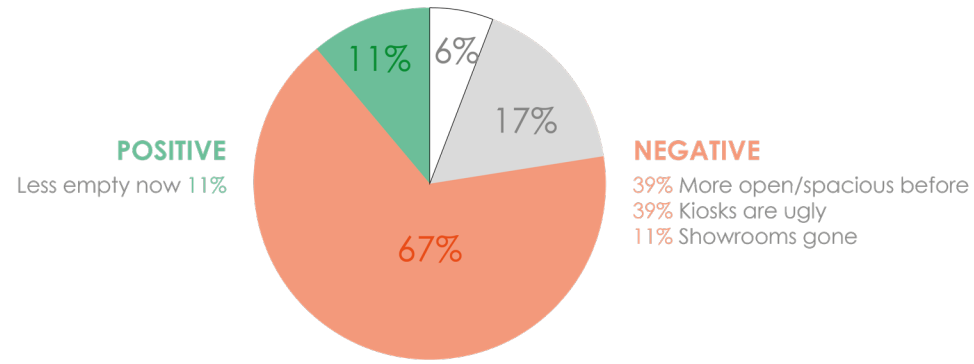

SPATIAL ORGANISATION
(n=18)

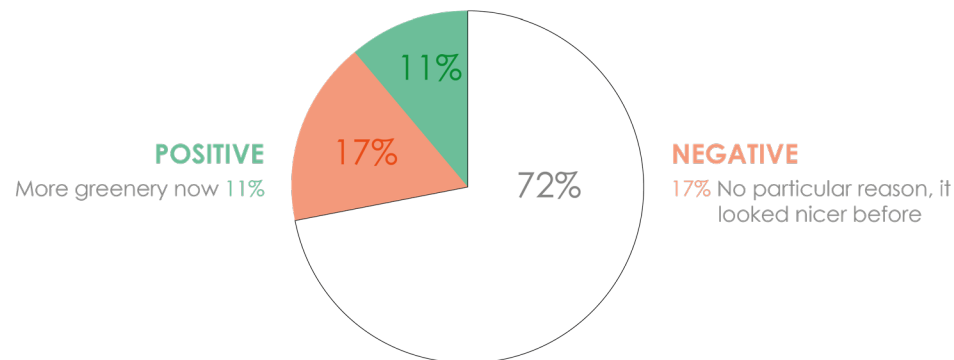

GREENERY
(n=18)

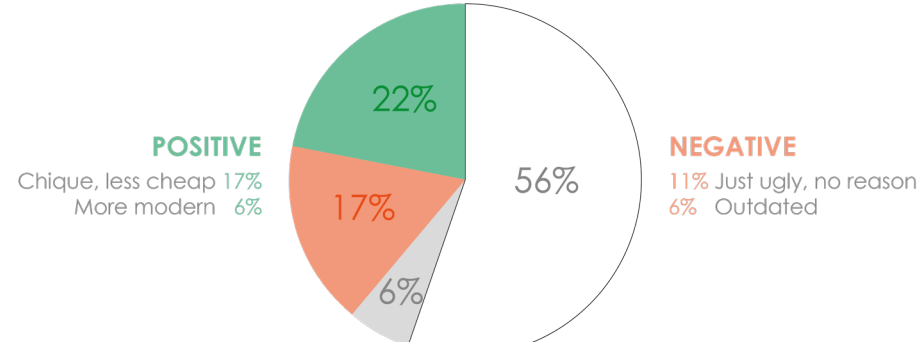

CANOPIES
(n=18)

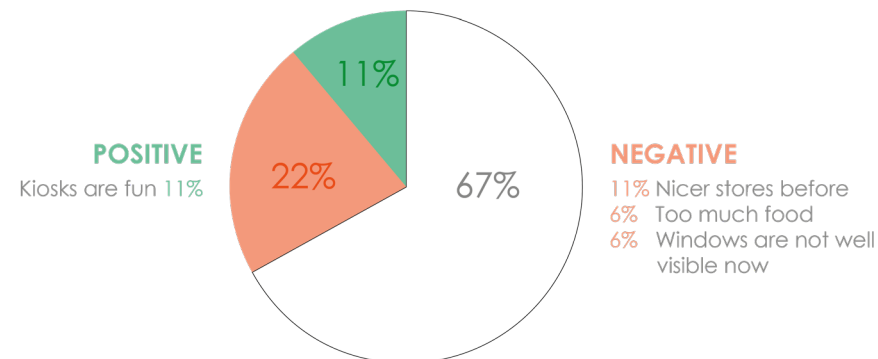

PROGRAM-RELATED
(n=18)

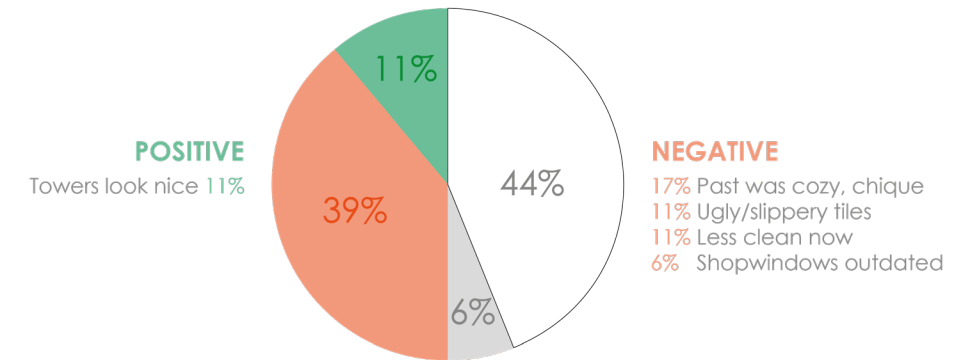

CONTEXT (OTHER FACTORS)
(n=18)

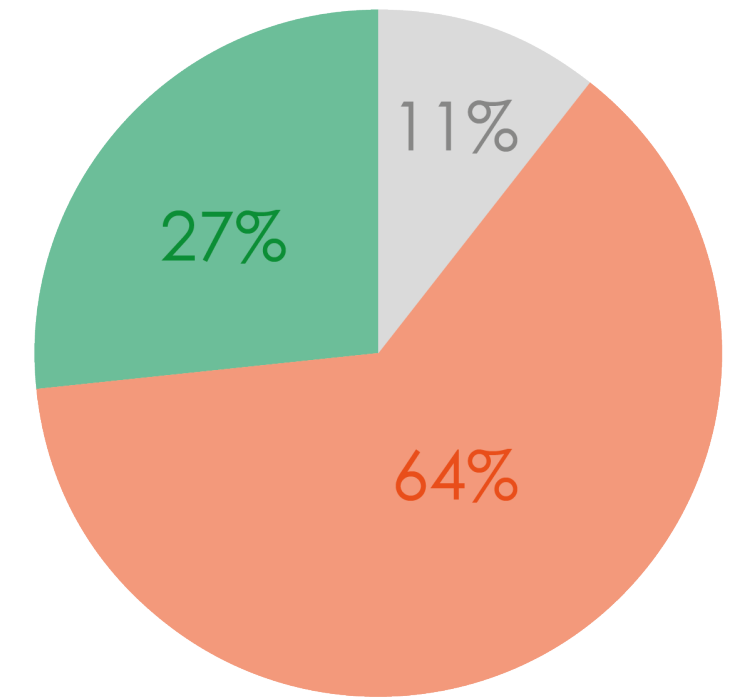

ORIGINAL LIJNBAAN
(n=18, 46 comments)

- Positive opinion on new
- Negative opinion on new
- Indifferent
- Topic not mentioned

RESEARCH

Interview results



RESEARCH

Interview results



1961



2022

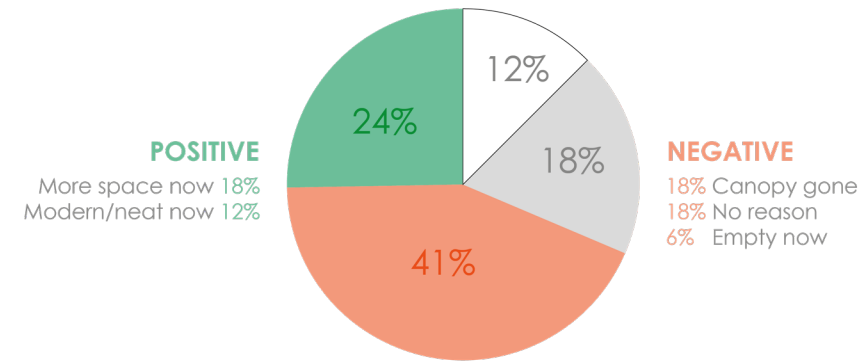

SPATIAL ORGANISATION
(n=17)

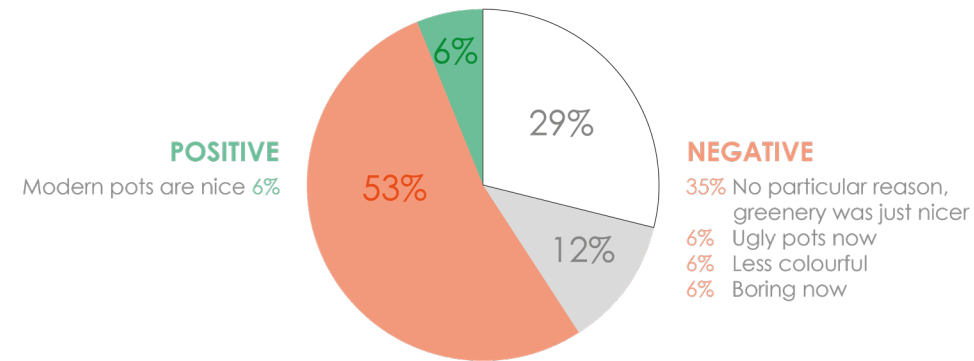

GREENERY
(n=17)

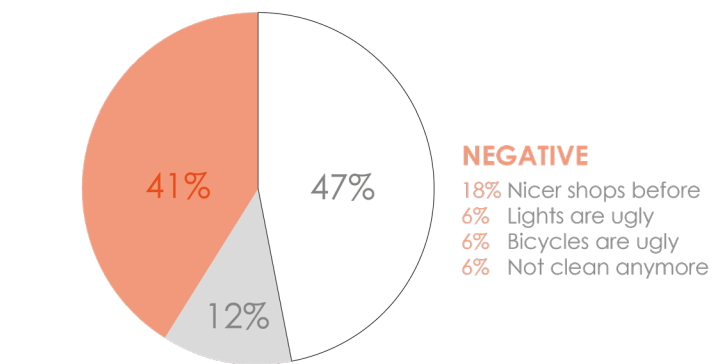

CONTEXT (OTHER FACTORS)
(n=17)

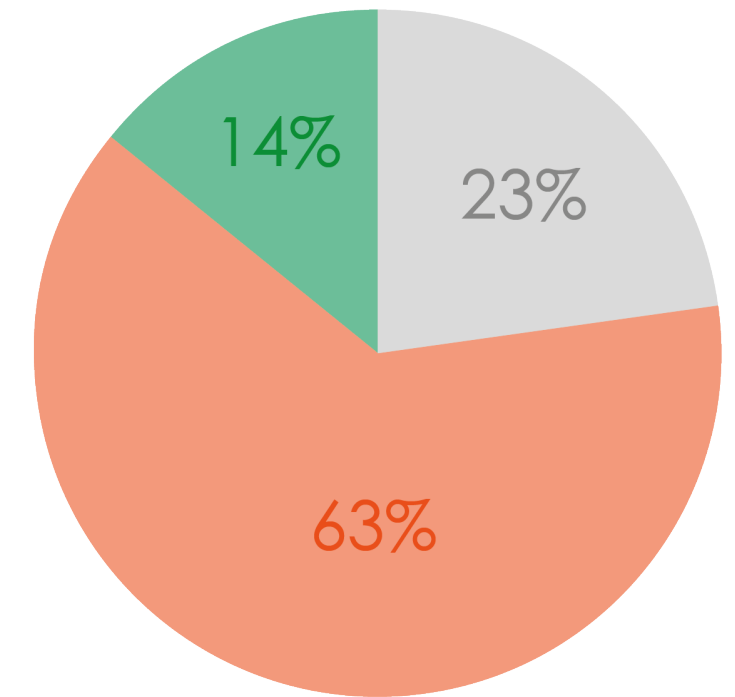

KORTE LIJNBAAN
(n=17, 35 comments)

- Positive opinion on new
- Negative opinion on new
- Indifferent
- Topic not mentioned

RESEARCH

Interview results



RESEARCH

Interview results



1956



2022

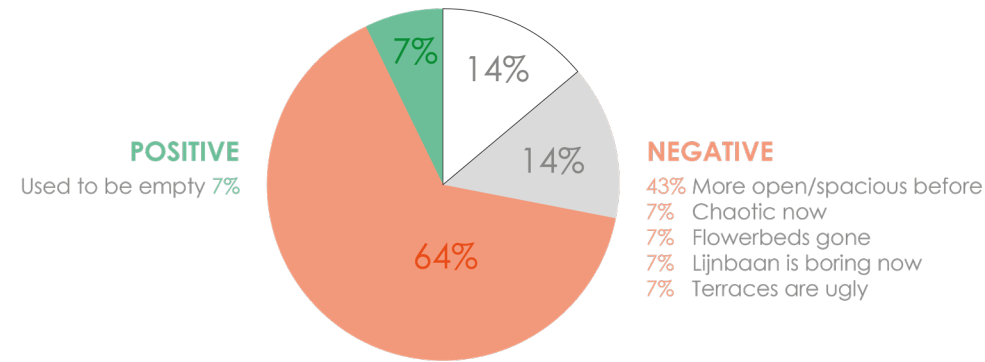

SPATIAL ORGANISATION
(n=14)

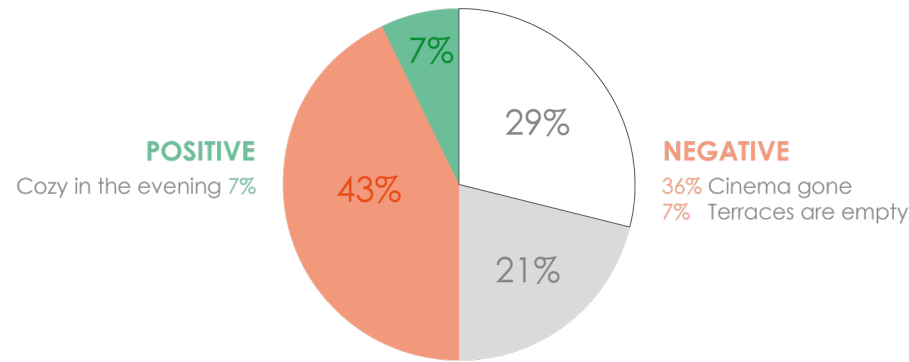

PROGRAM-RELATED
(n=14)

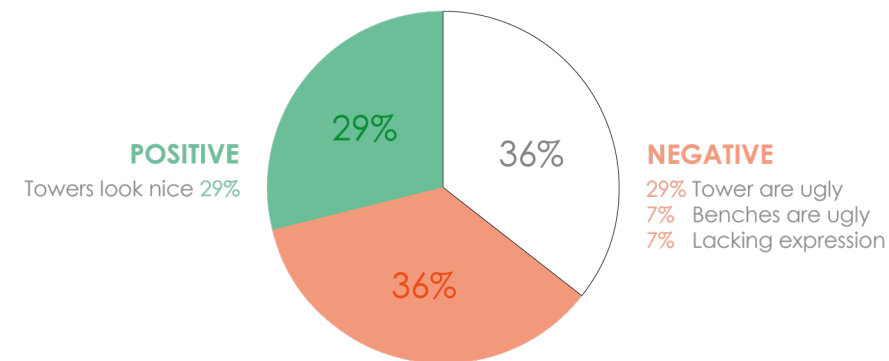

CONTEXT (OTHER FACTORS)
(n=14)

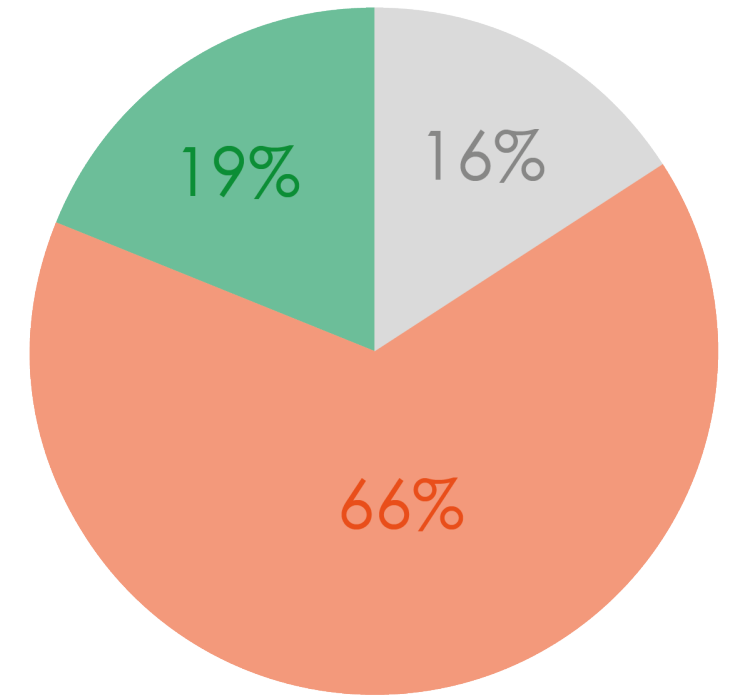

LIJNBAAN-KRUISKADE
(n=14, 32 comments)

- Positive opinion on new
- Negative opinion on new
- Indifferent
- Topic not mentioned

RESEARCH

Interview results

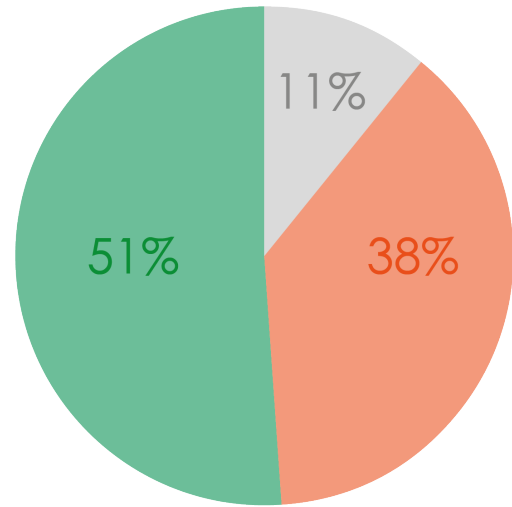

OLD HOSPITAL SQUARE
(n=19, 37 comments)

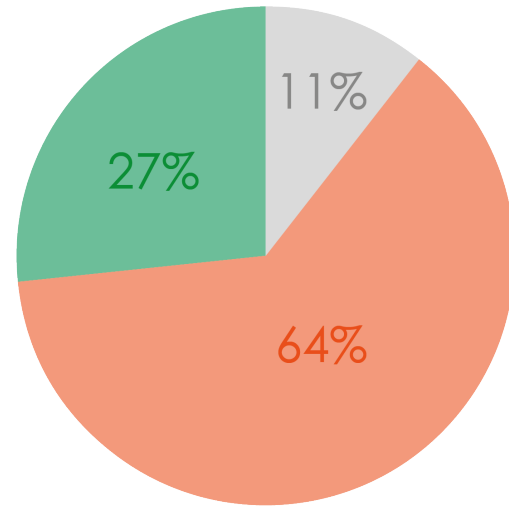

ORIGINAL LIJNBAAN
(n=18, 46 comments)

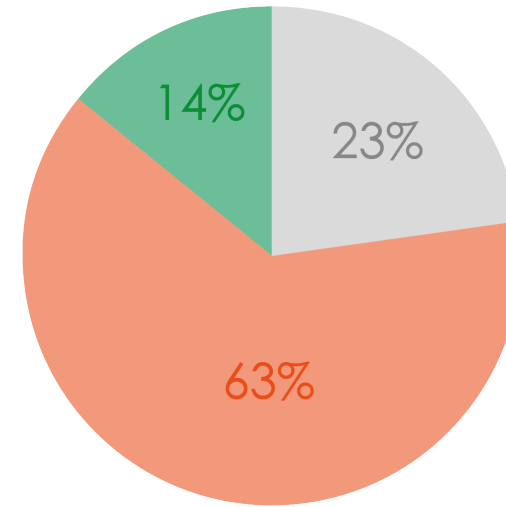

KORTE LIJNBAAN
(n=17, 35 comments)

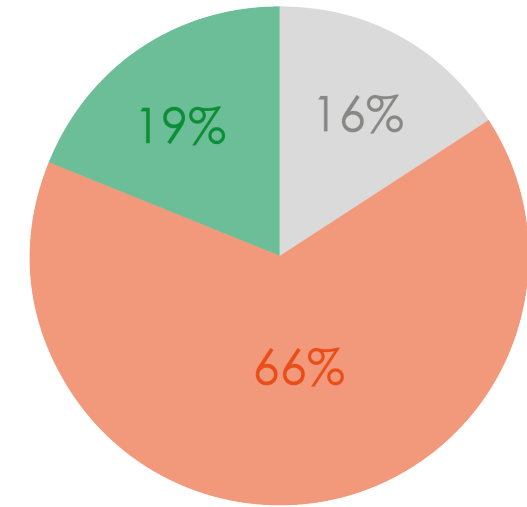

LIJNBAAN-KRUISKADE
(n=14, 32 comments)

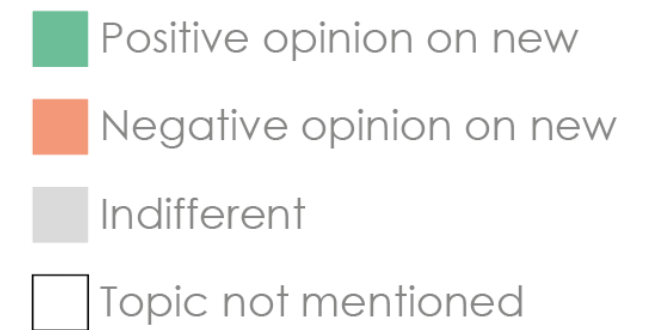

RESEARCH

Interview results

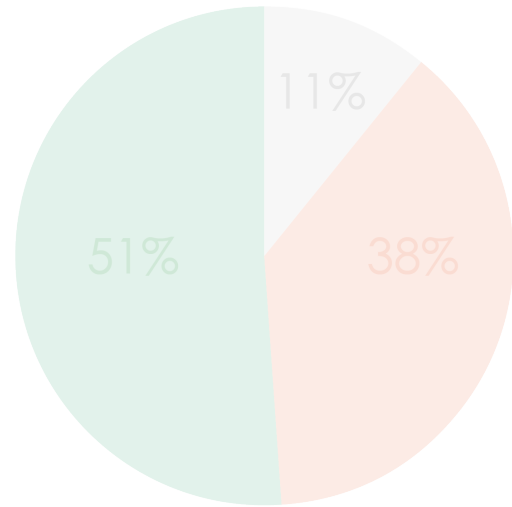

OLD HOSPITAL SQUARE
(n=19, 37 comments)

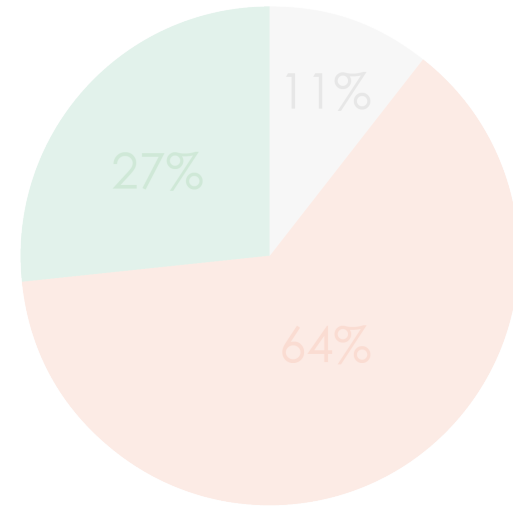

ORIGINAL LIJNBAAN
(n=18, 46 comments)

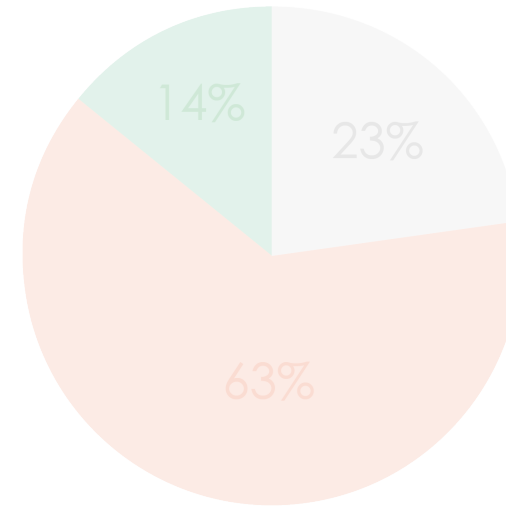

KORTE LIJNBAAN
(n=17, 35 comments)

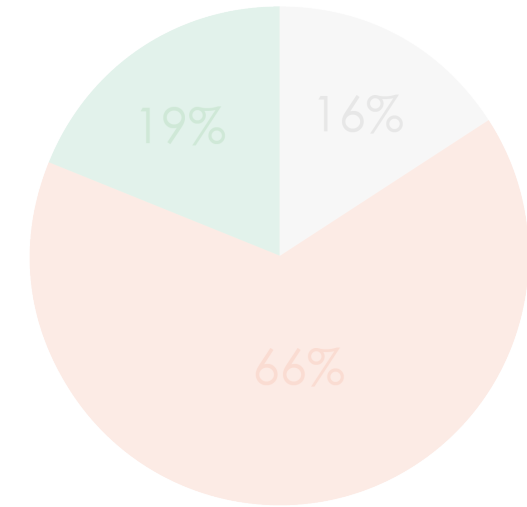

LIJNBAAN-KRUISKADE
(n=14, 32 comments)

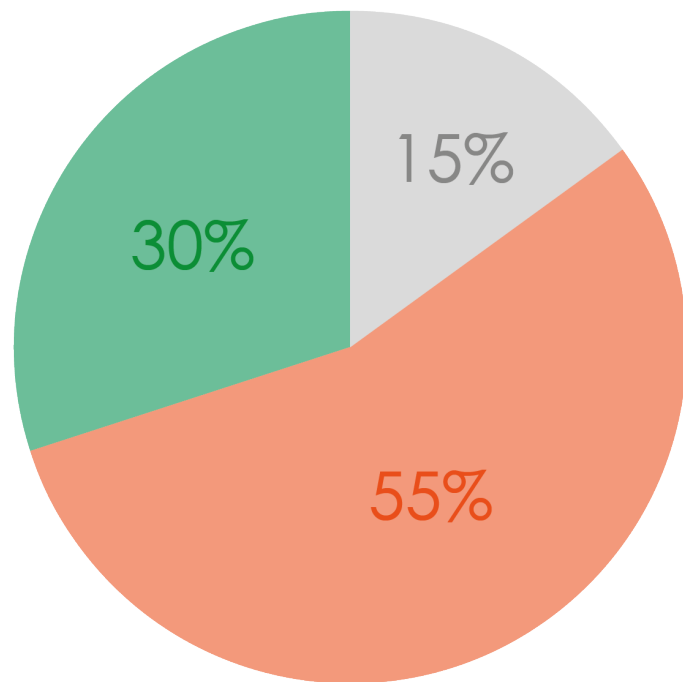

LIJNBAAN TOTAL
(n=78, 160 comments)

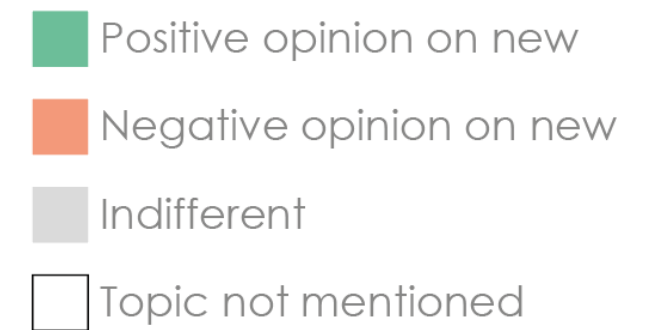

RESEARCH

Interview results

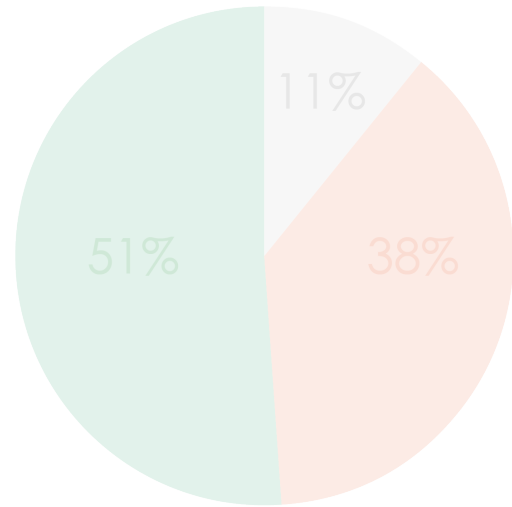

OLD HOSPITAL SQUARE
(n=19, 37 comments)

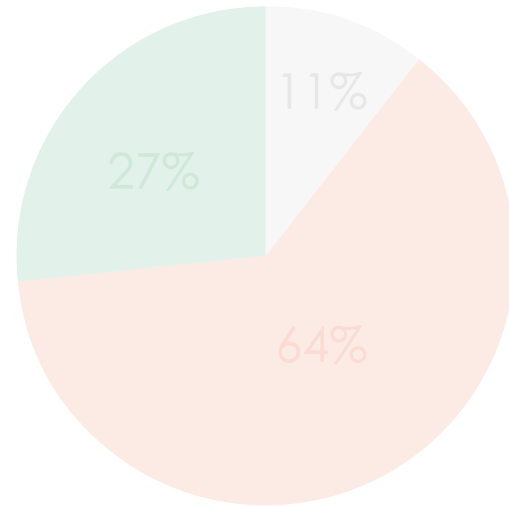

ORIGINAL LIJNBAAN
(n=18, 46 comments)

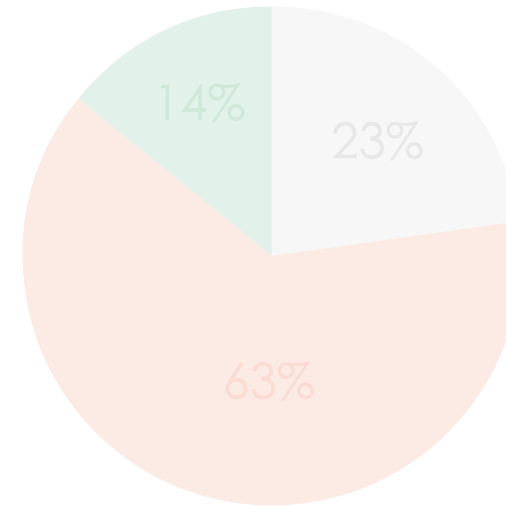

KORTE LIJNBAAN
(n=17, 35 comments)

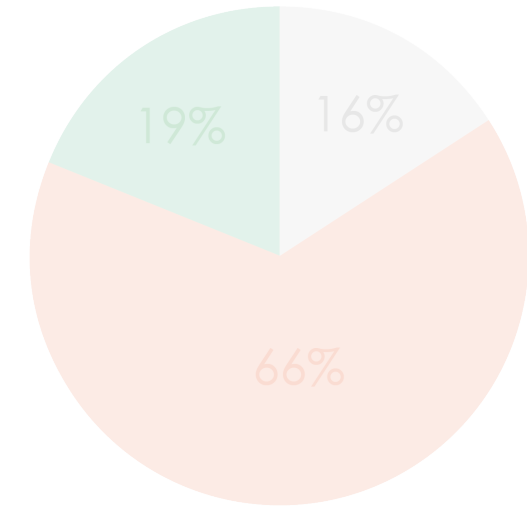

LIJNBAAN-KRUISKADE
(n=14, 32 comments)

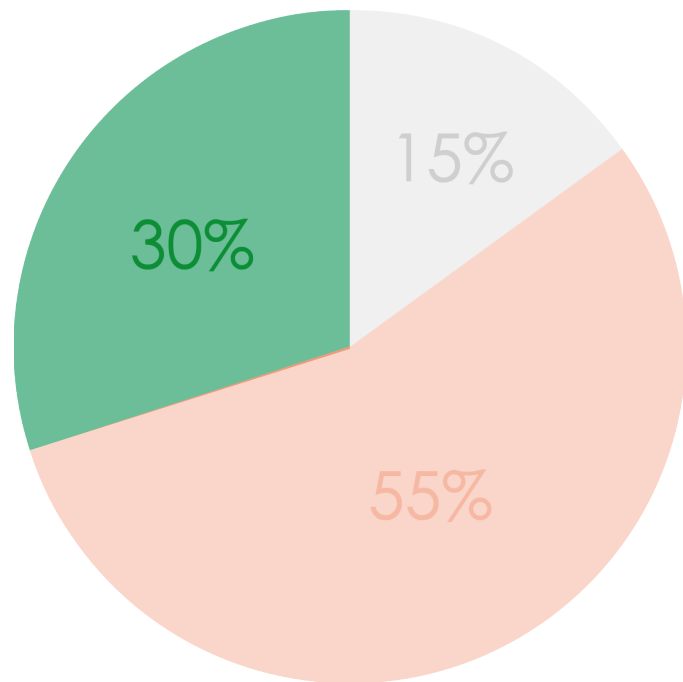

LIJNBAAN TOTAL
(n=78, 160 comments)

MOST MENTIONED TOPICS

(n=78)

POSITIVE

- 1. More 'open' spatially 21%
- 2. Use of greenery 12%
- 3. Façade and canopy materials 12%
- 4. Highrises in the background 10%

- Positive opinion on new
- Negative opinion on new
- Indifferent
- Topic not mentioned

RESEARCH

Interview results

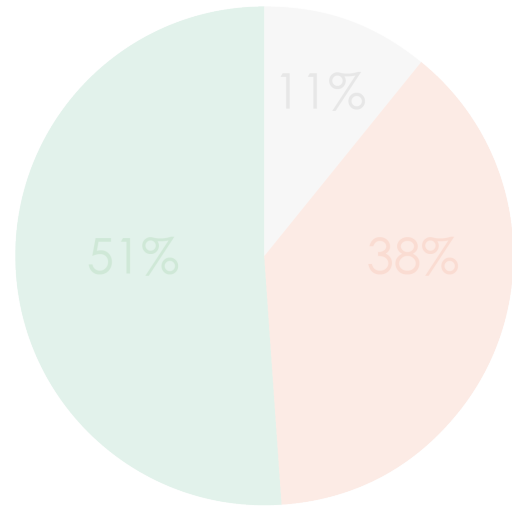

OLD HOSPITAL SQUARE
(n=19, 37 comments)

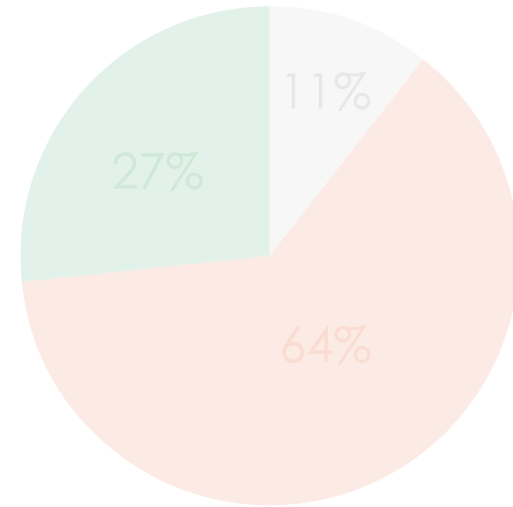

ORIGINAL LIJNBAAN
(n=18, 46 comments)

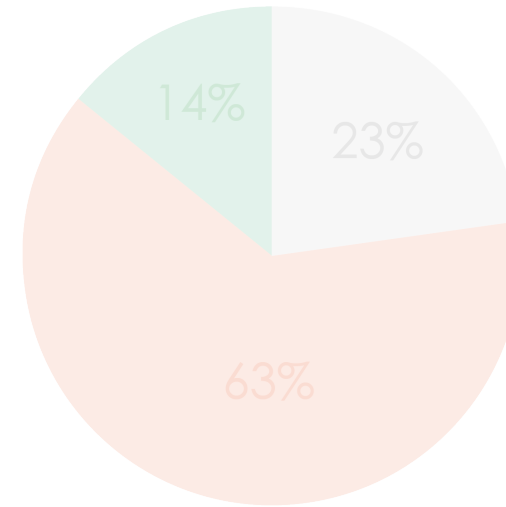

KORTE LIJNBAAN
(n=17, 35 comments)

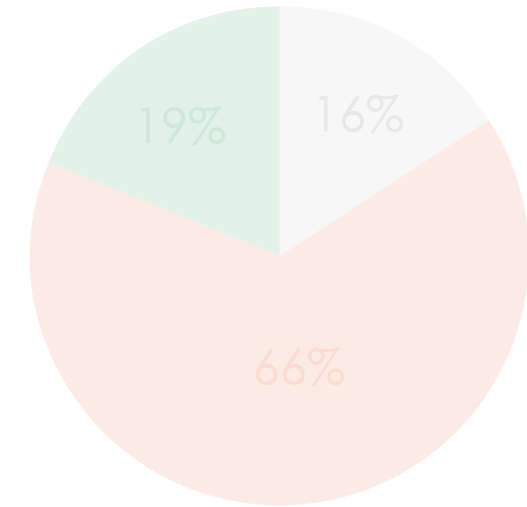

LIJNBAAN-KRUISKADE
(n=14, 32 comments)

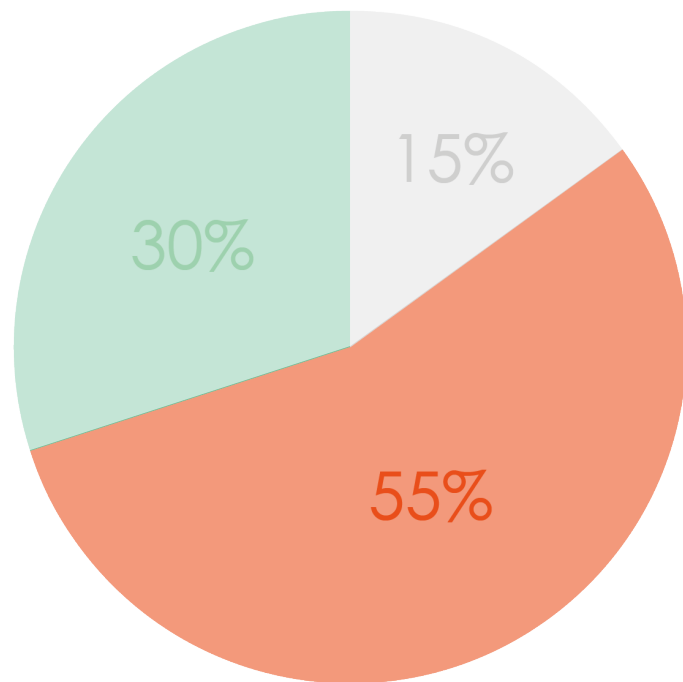

LIJNBAAN TOTAL
(n=78, 160 comments)

MOST MENTIONED TOPICS

(n=78)

POSITIVE

- More 'open' spatially 21%
- Use of greenery 12%
- Façade and canopy materials 12%
- Highrises in the background 10%

NEGATIVE

1. 37% Less 'open' spatially
2. 26% Past atmosphere/functions
3. 19% Past use of greenery
4. 10% Façade and canopy materials

- Positive opinion on new
- Negative opinion on new
- Indifferent
- Topic not mentioned

RESEARCH

Conclusions

How do interventions in the spatial composition influence the way visitors navigate a Dutch post-war shopping mall?

SUBTRACTION

Removing, downsizing, dismantling of a volume

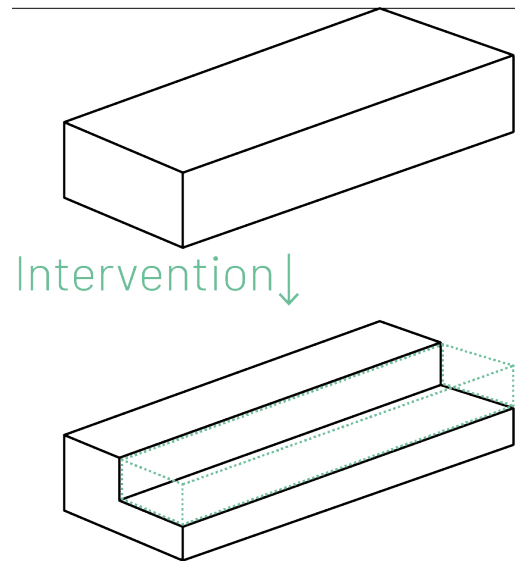

Buildings: +
Greenery: -

1+1=2

Adding a new, contrasting volume next to the existing

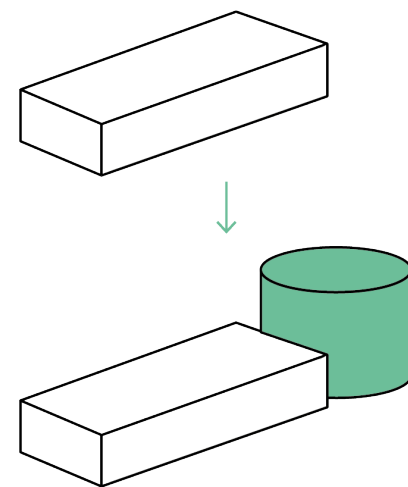

Mostly: -
Chaotic

1+1=1

Adding a new volume that merges with the existing

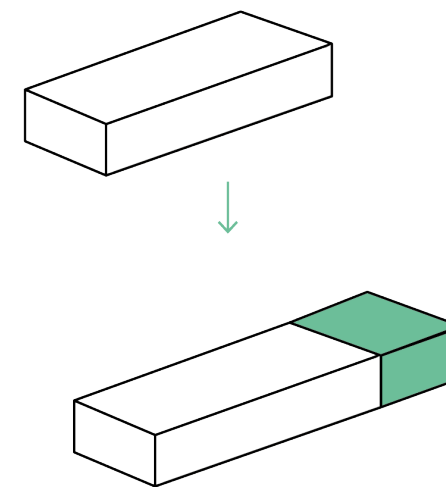

Not mentioned often
Only when gone

FACE-LIFT

Improving the façade with design, as well as the installations

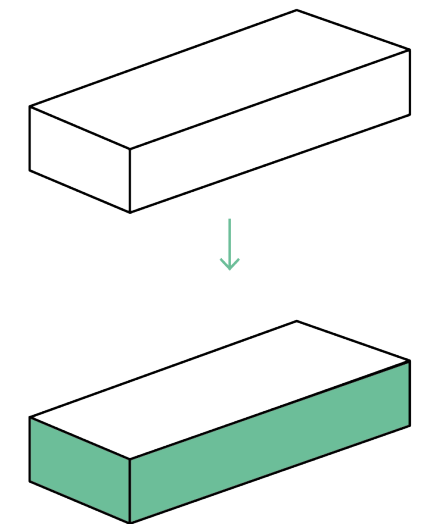

Mixed answers

RESEARCH

Conclusions

How do interventions in the spatial composition influence the way visitors navigate a Dutch post-war shopping mall?

SUBTRACTION

Removing, downsizing, dismantling of a volume

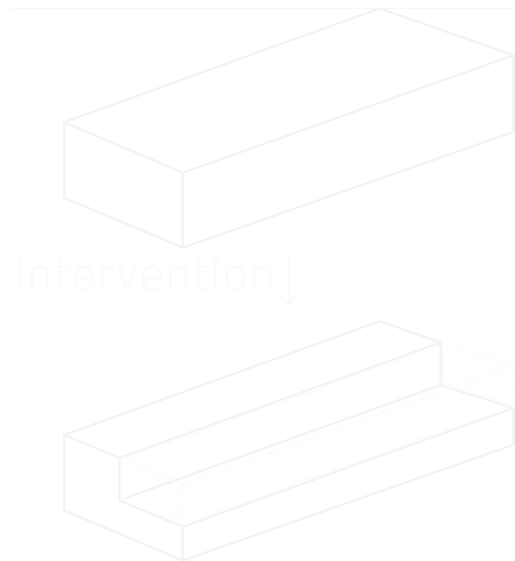

Buildings: +
Greenery: -

More visual access / openness

Adding a new, contrasting volume next to the existing

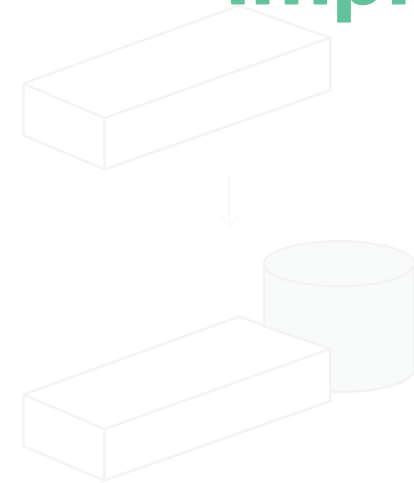

Mostly: -
Chaotic

Adding a new volume that merges with the existing

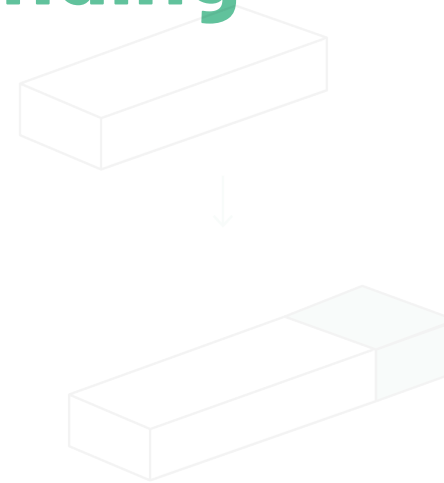

Not mentioned often
Only when gone

FACE-LIFT

Improving the façade with design, as well as the installations

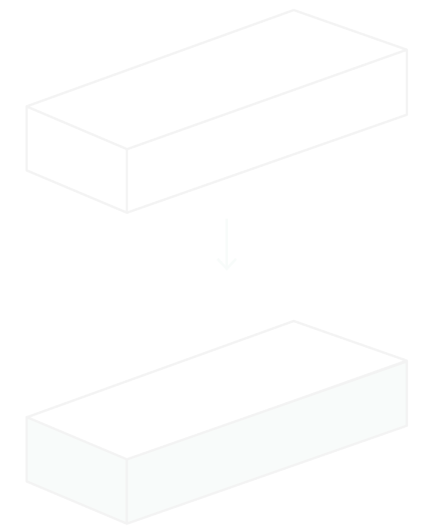

Mixed answers

Better legibility

Improved wayfinding

DESIGN

NEGATIVE

37% Less 'open' spatially

26% Past atmosphere/functions

19% Past use of greenery

10% Façade and canopy materials

DESIGN

Less diversity in stores

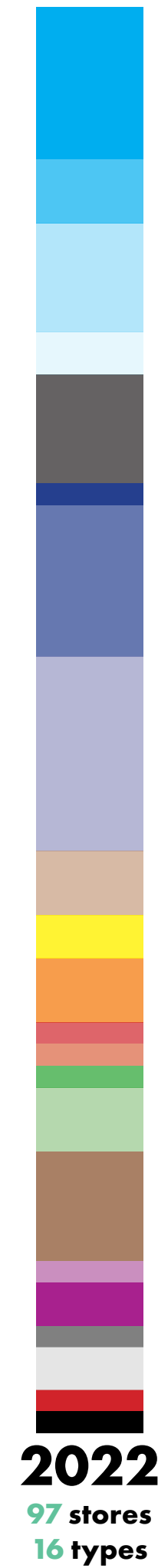
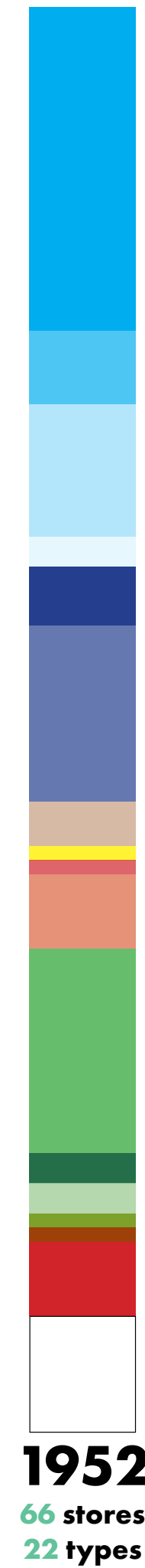
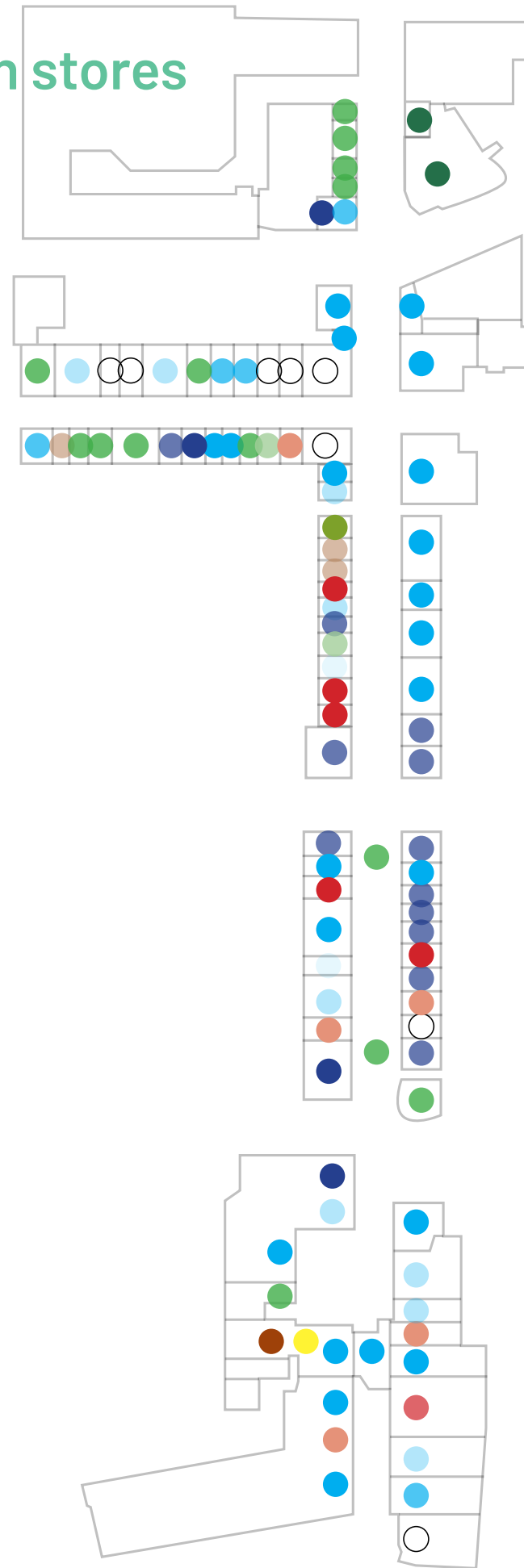

DESIGN

Design area



2023

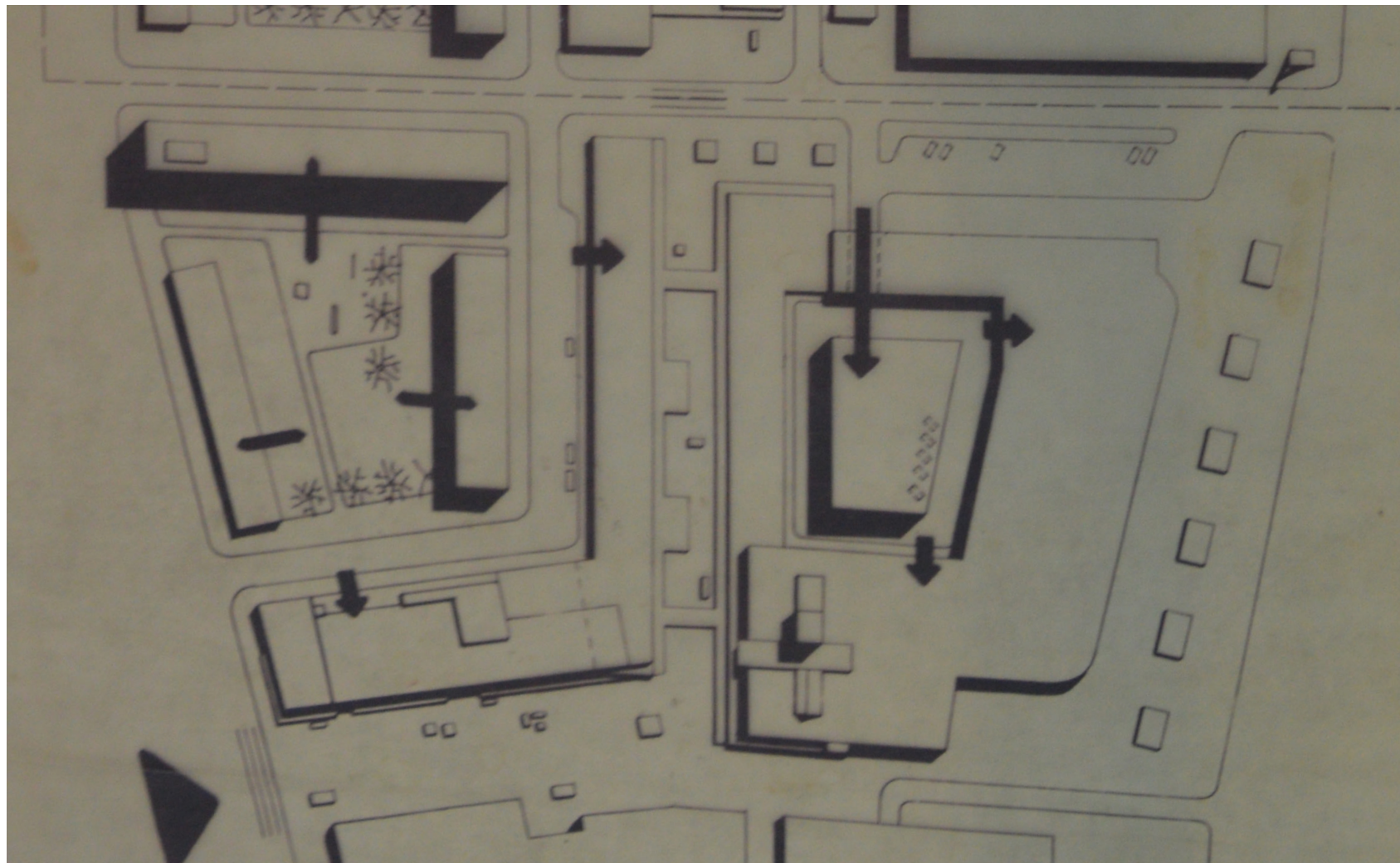

Original plan



Revised plan

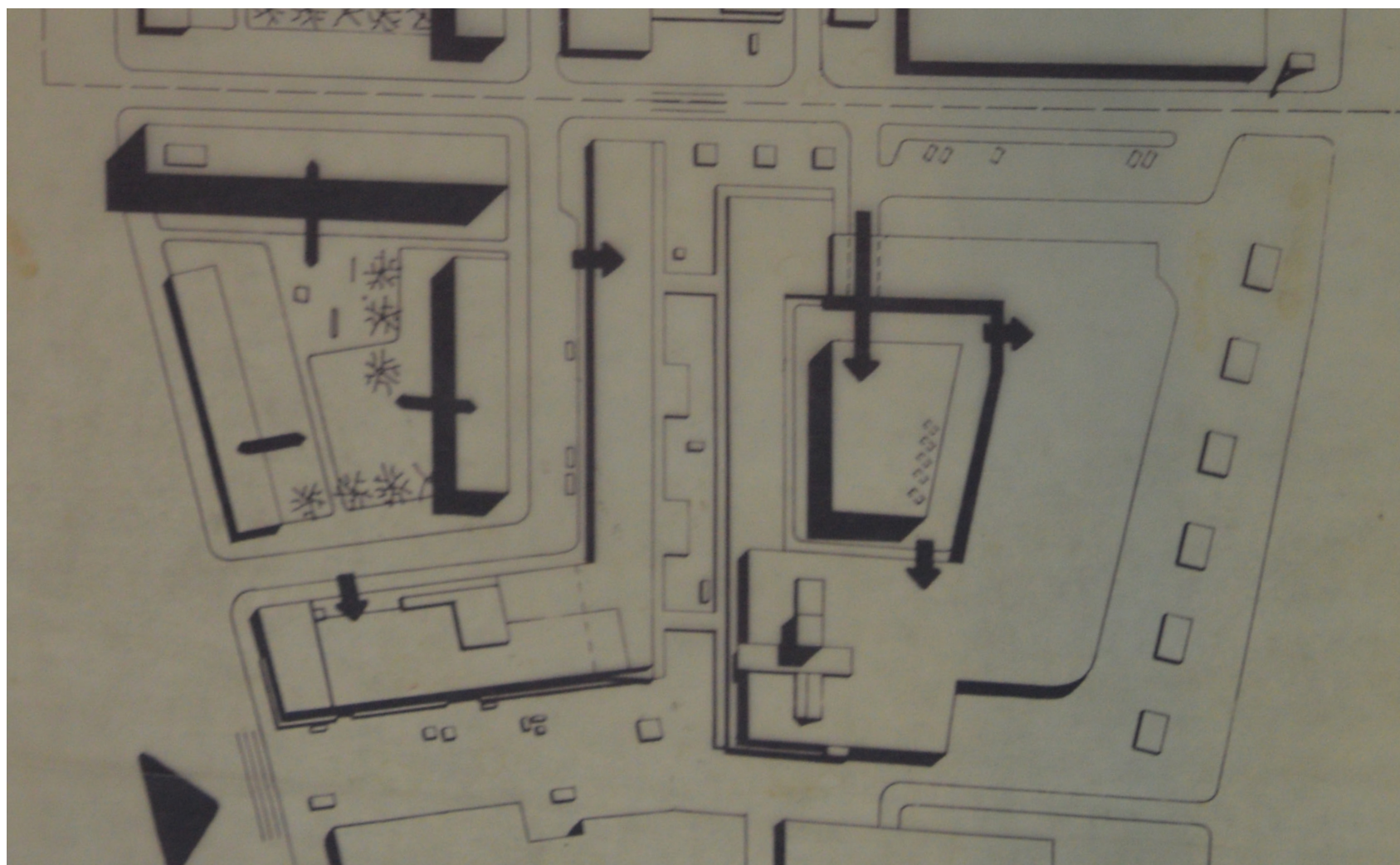

Original plan



2023

DESIGN

Current situation



DESIGN

Current situation



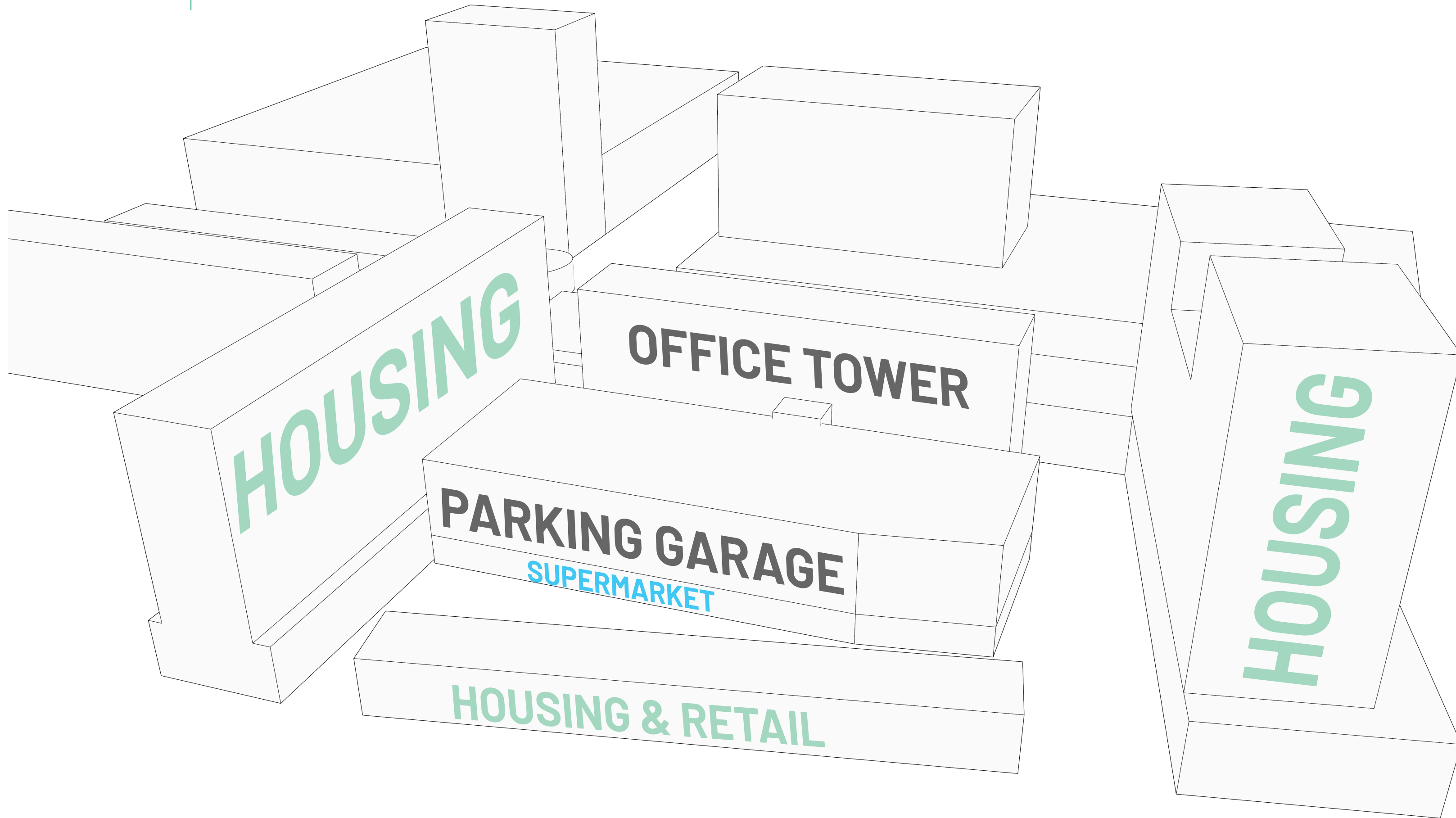

DESIGN

Past intervention

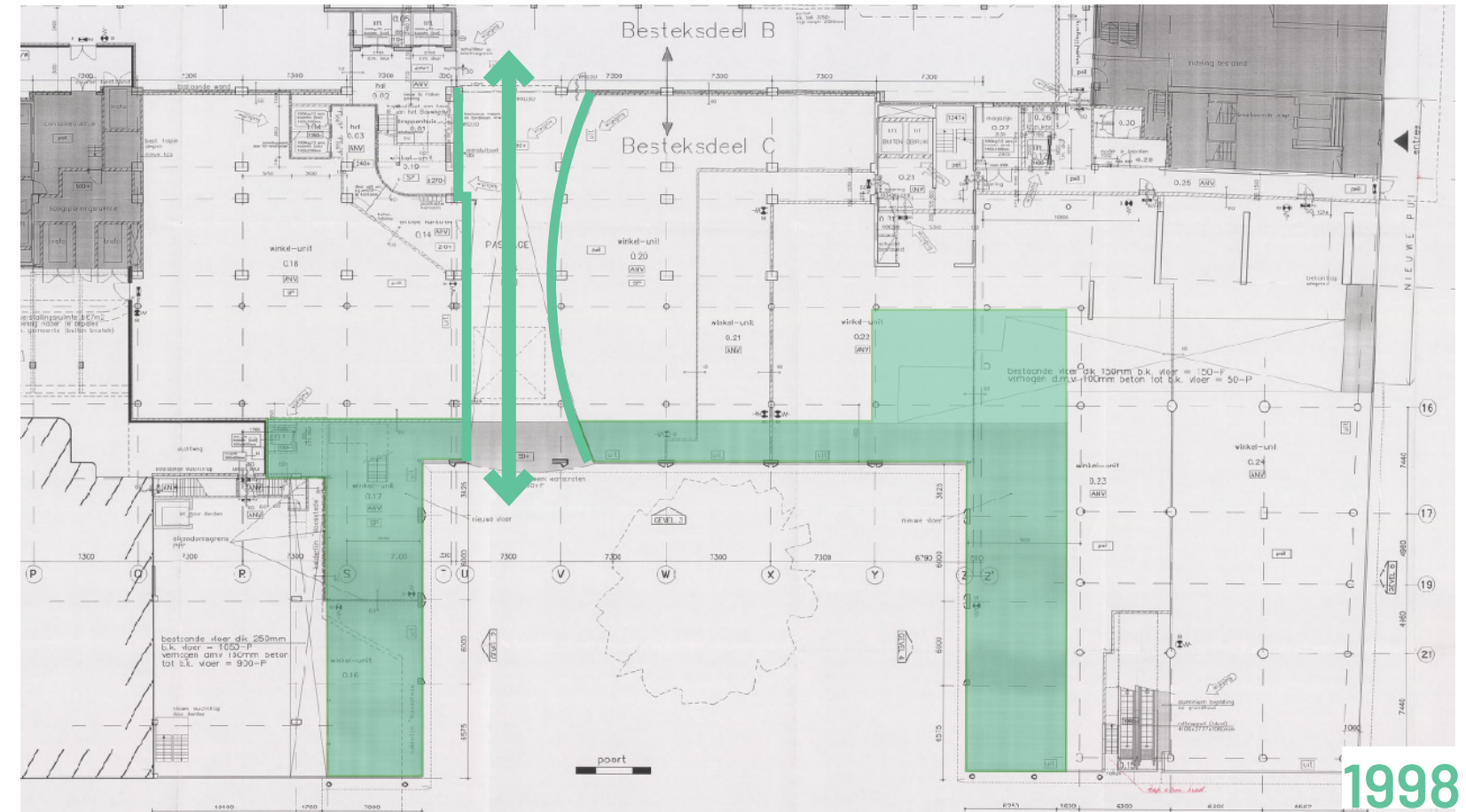
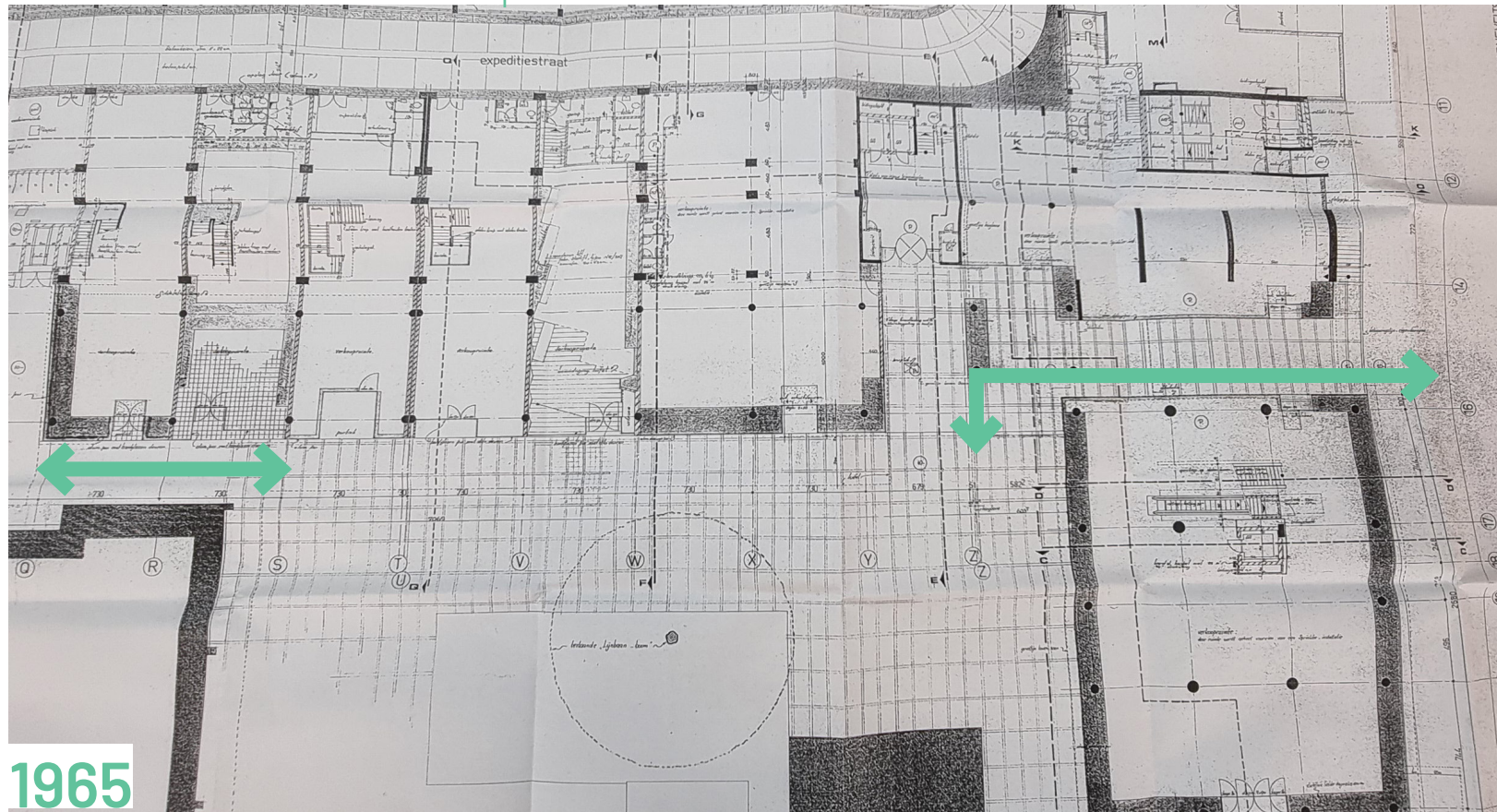

DESIGN

Future of parking in city center

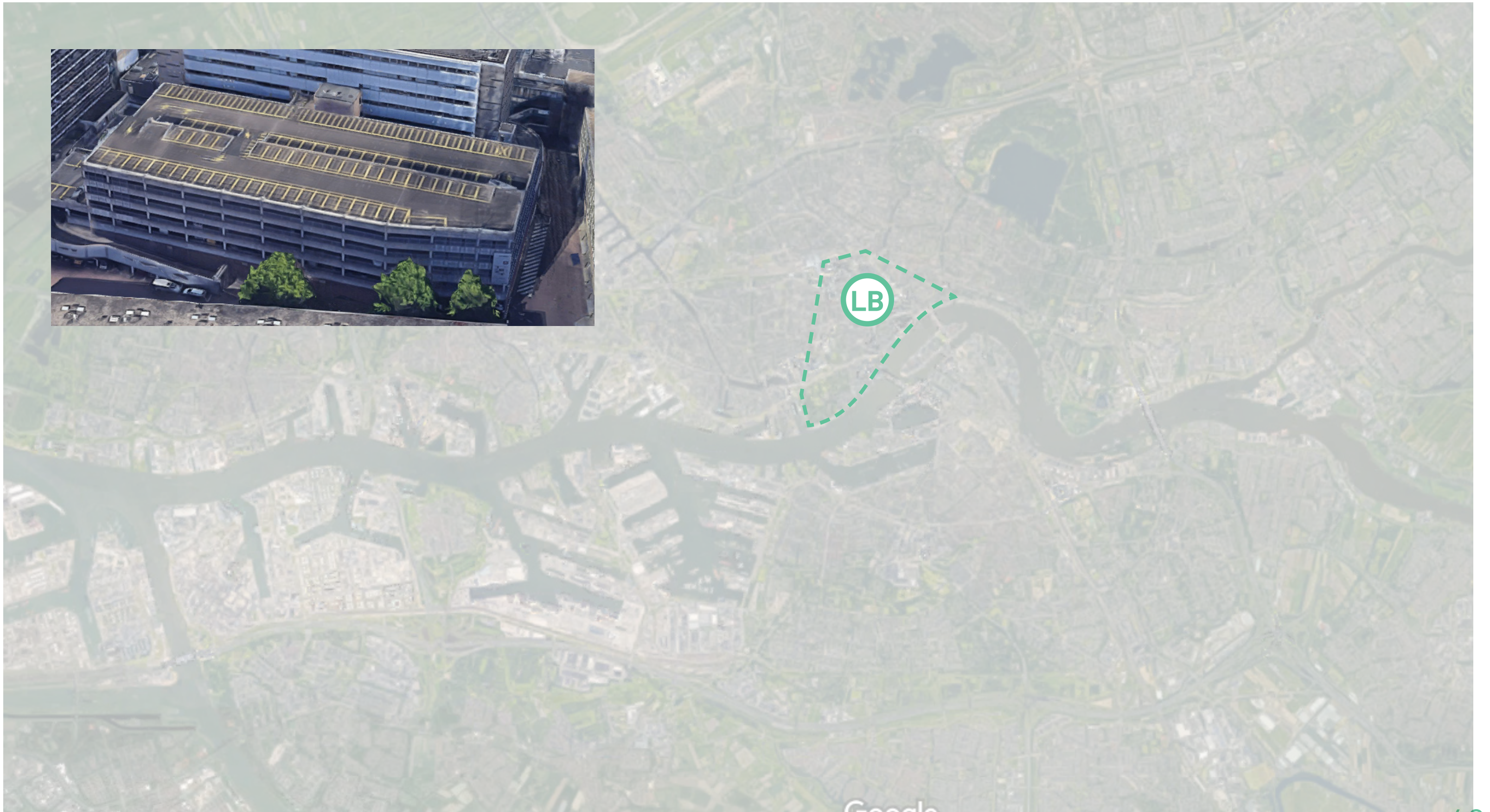

Google

DESIGN

Future of parking in city center

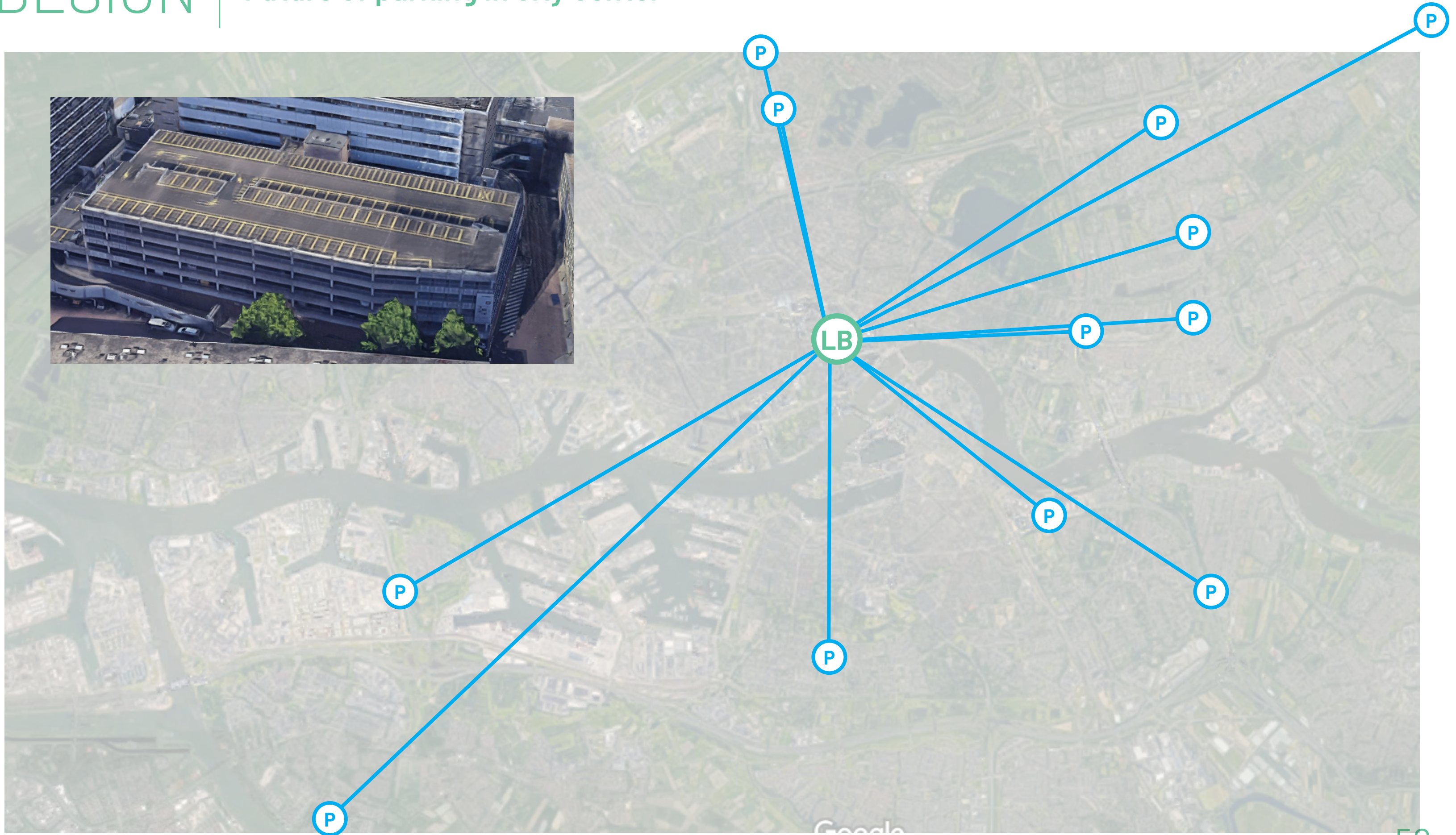

DESIGN

Starting points

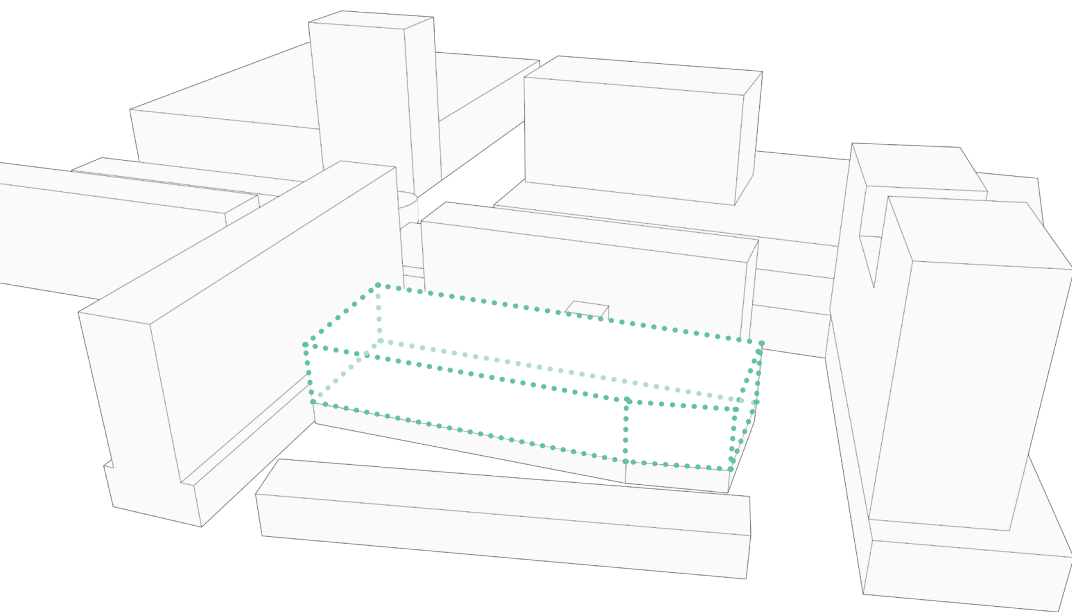
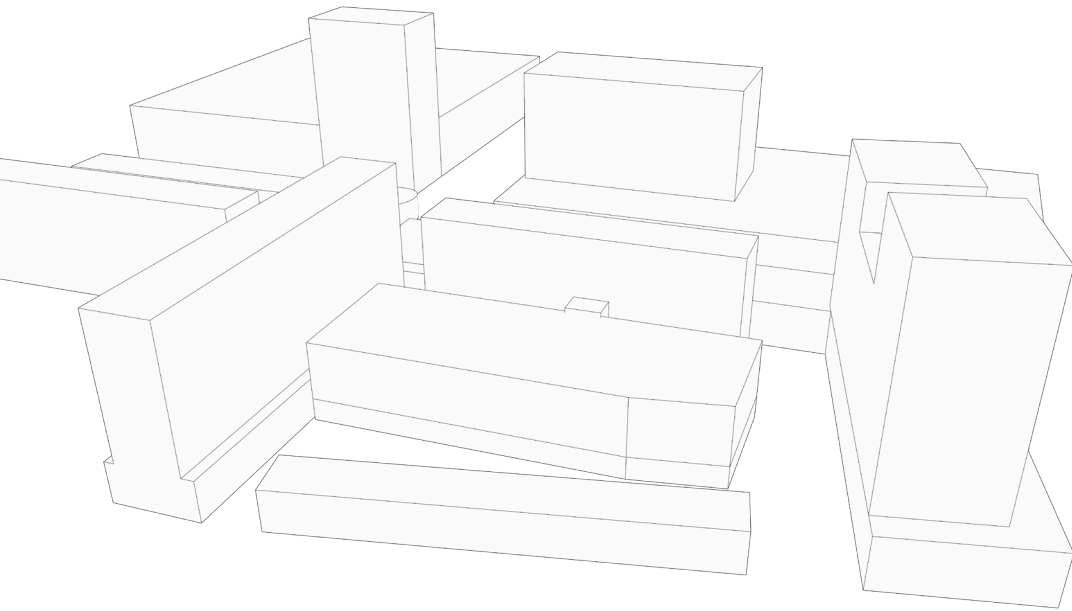

1. NO MORE PARKING

Visitors arrive with PT

DESIGN

Starting points

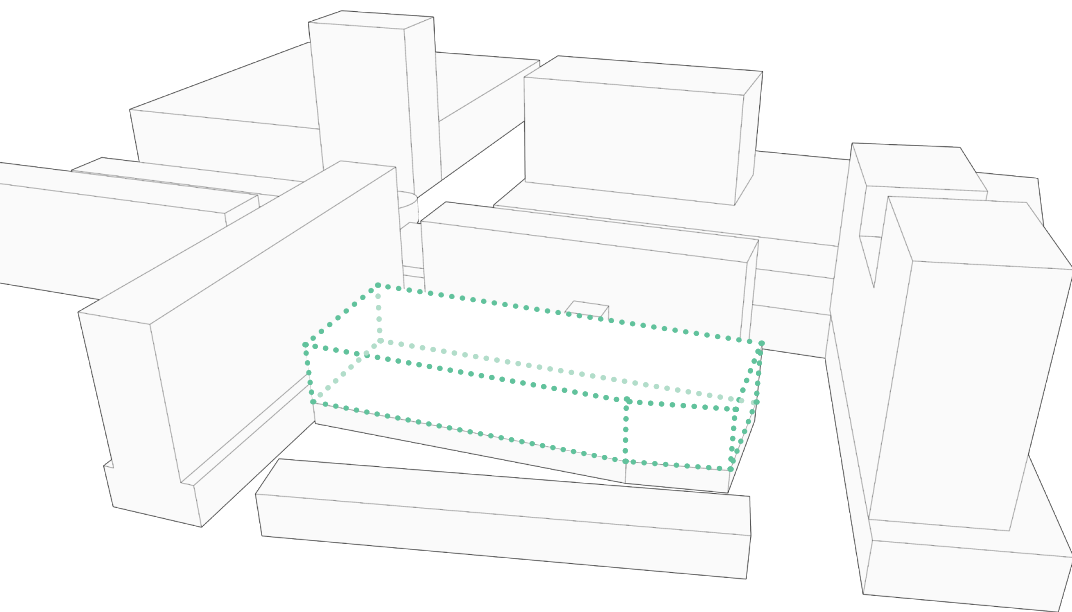
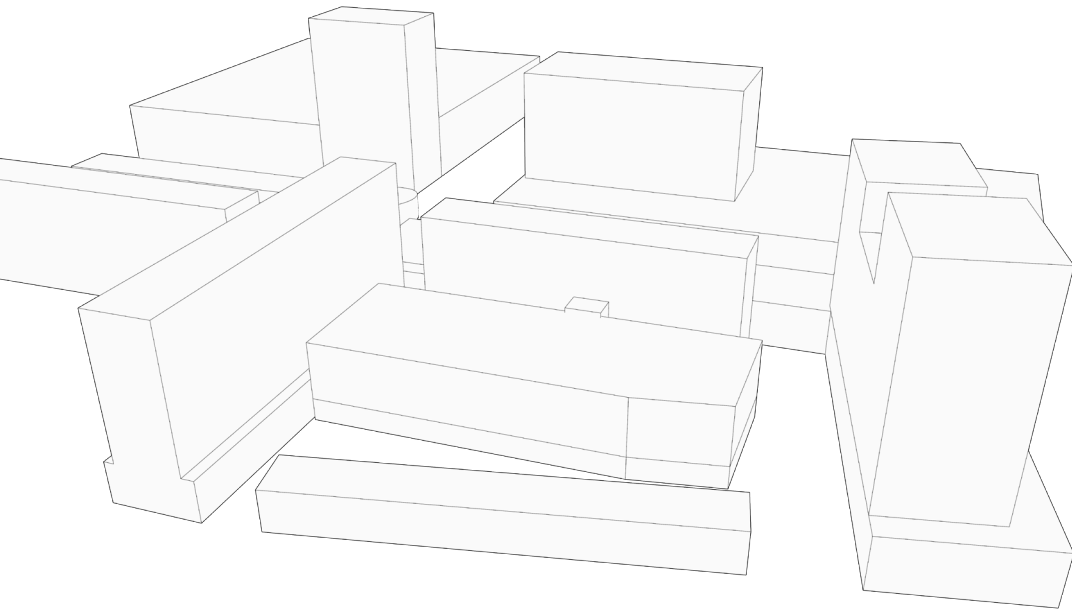

1. NO MORE PARKING

Visitors arrive with PT

2. OPENING UP

In the past Lijnbaan's spirit

DESIGN

Starting points

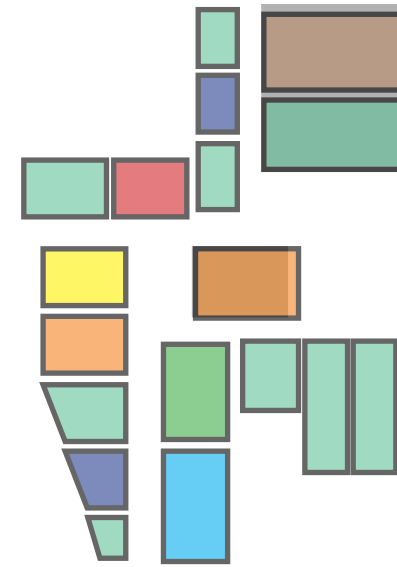
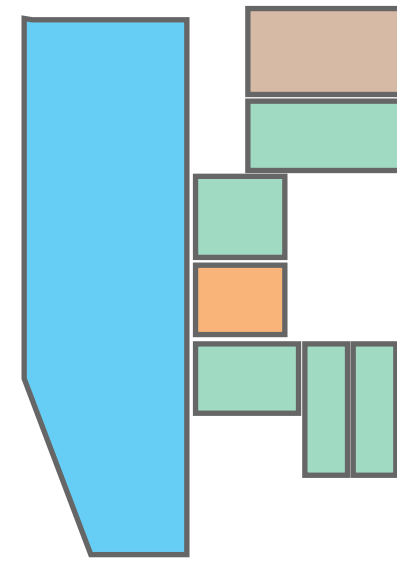
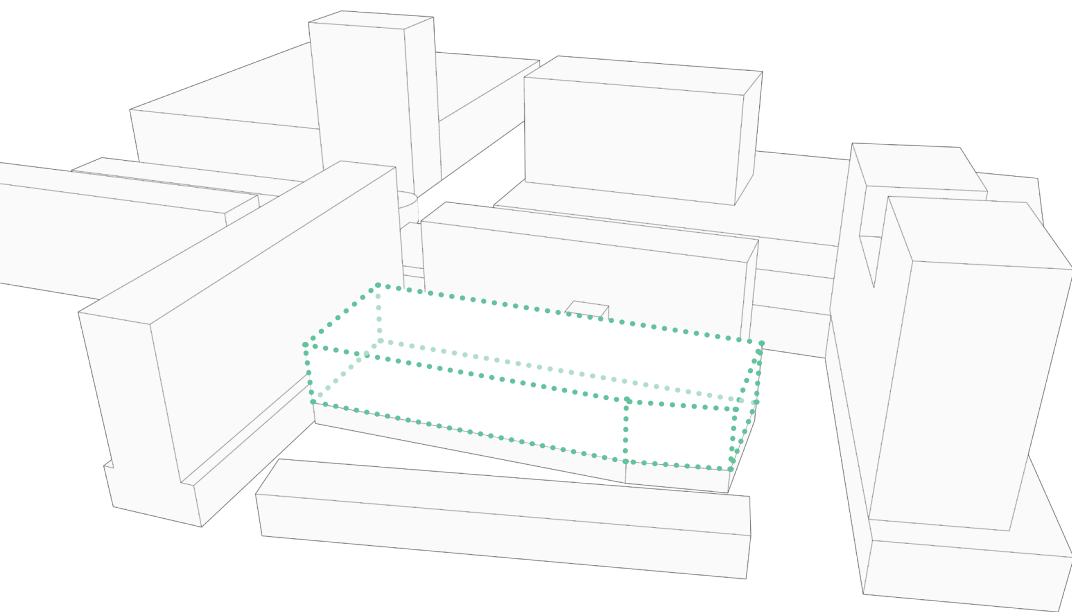
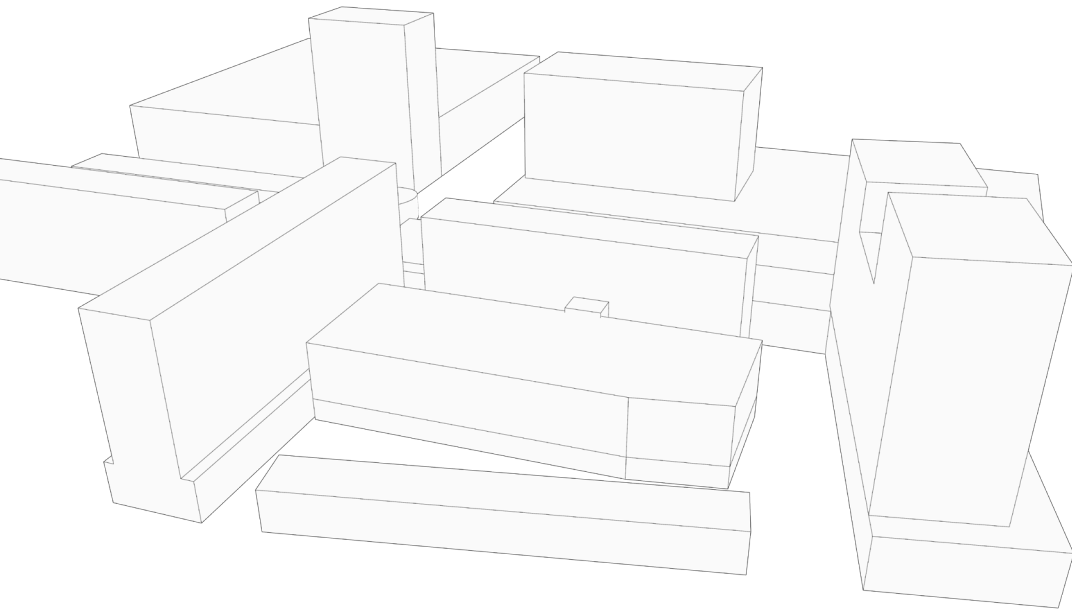

1. NO MORE PARKING

Visitors arrive with PT

2. OPENING UP

In the past Lijnbaan's spirit

3. SHOP DIVERSITY

'Store of the future'

DESIGN

Starting points

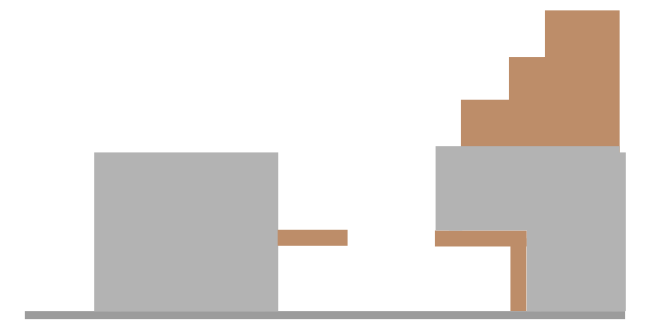
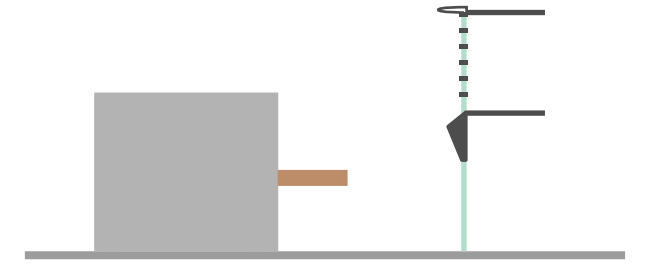
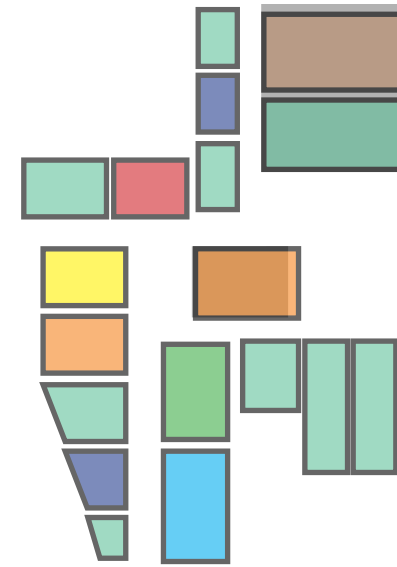
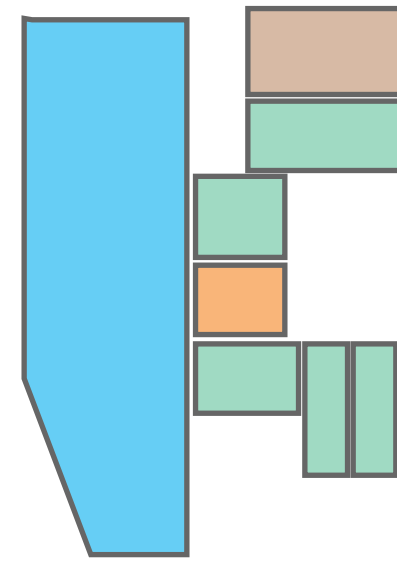
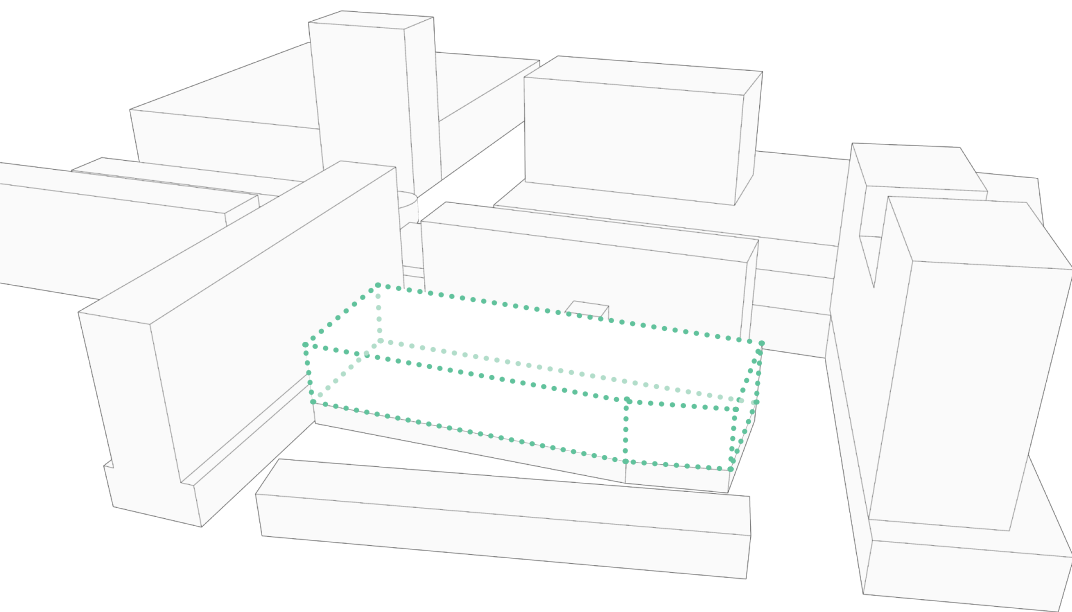
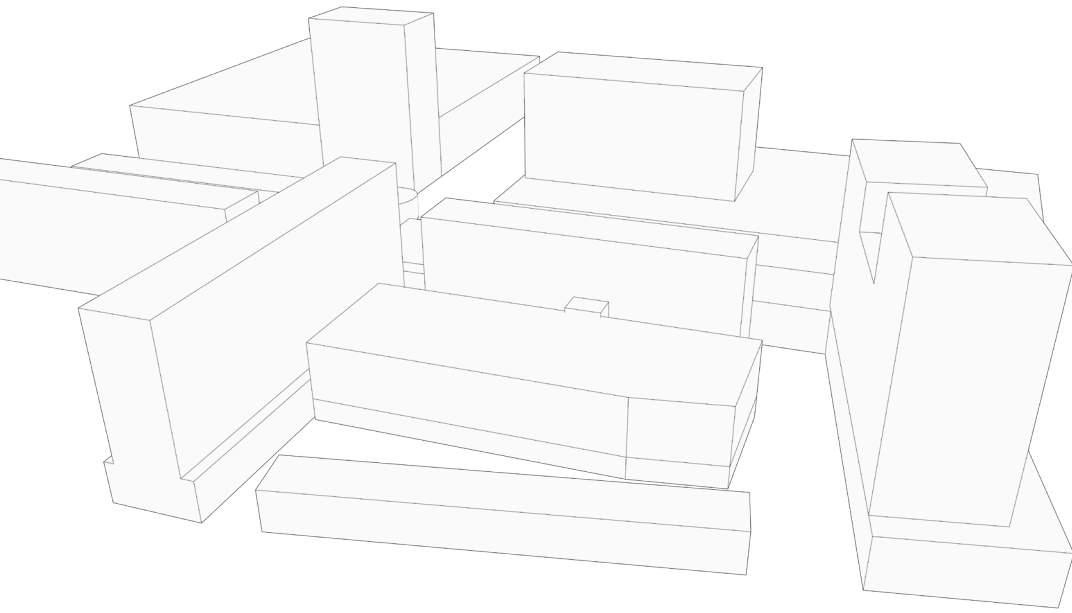

1. NO MORE PARKING

Visitors arrive with PT

2. OPENING UP

In the past Lijnbaan's spirit

3. SHOP DIVERSITY

'Store of the future'

4. COHERENCE

Unity in diversity

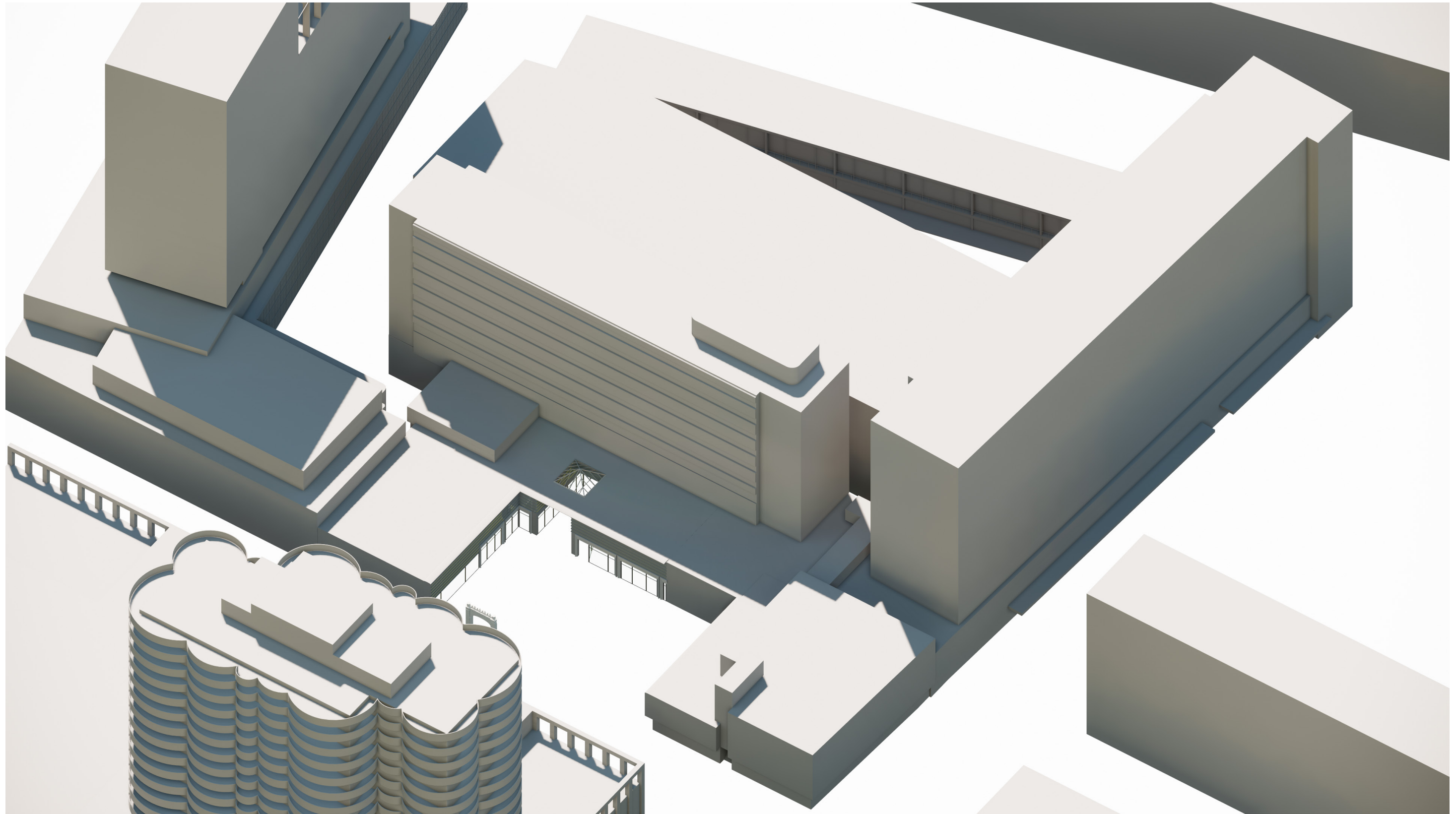

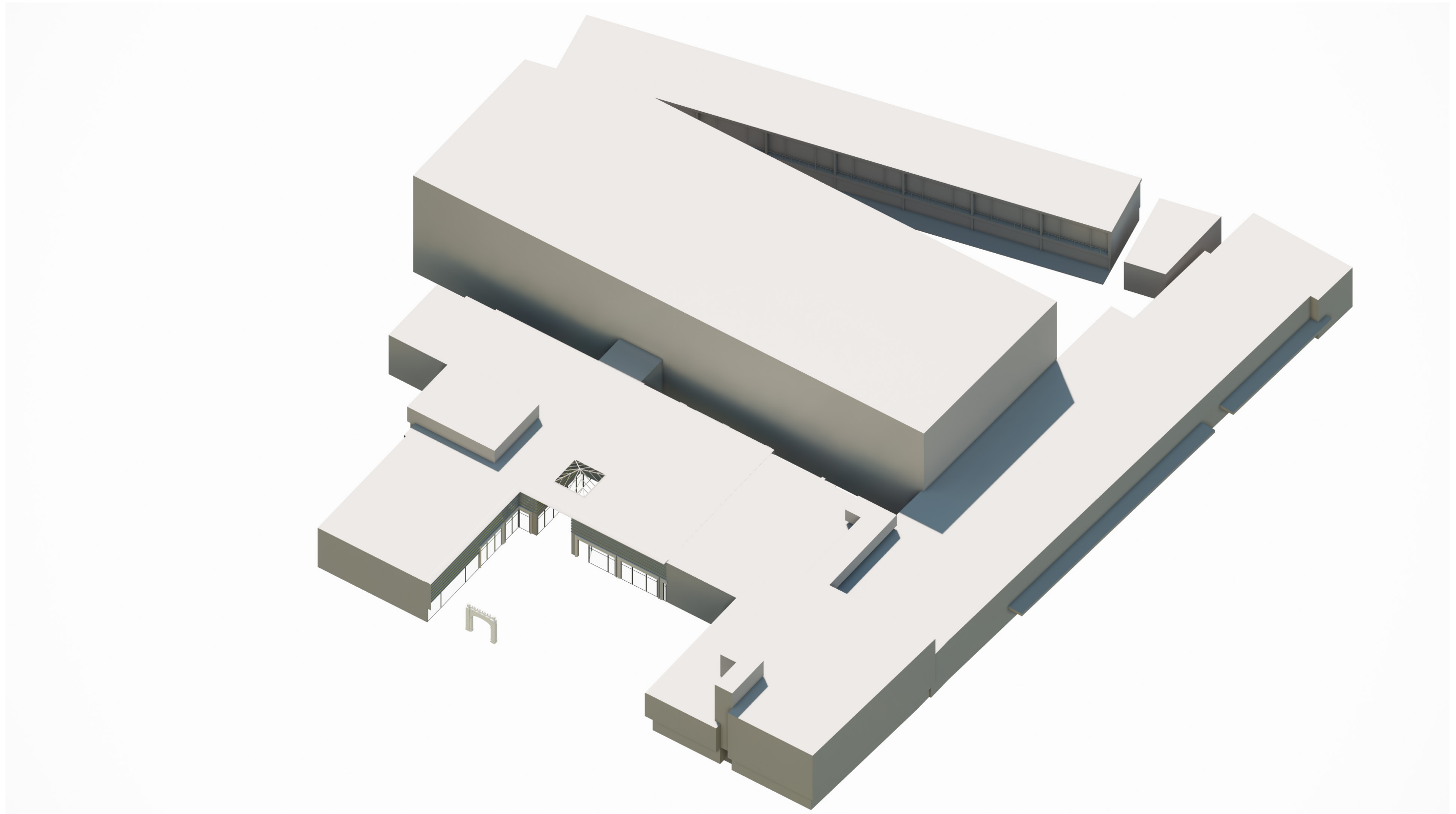

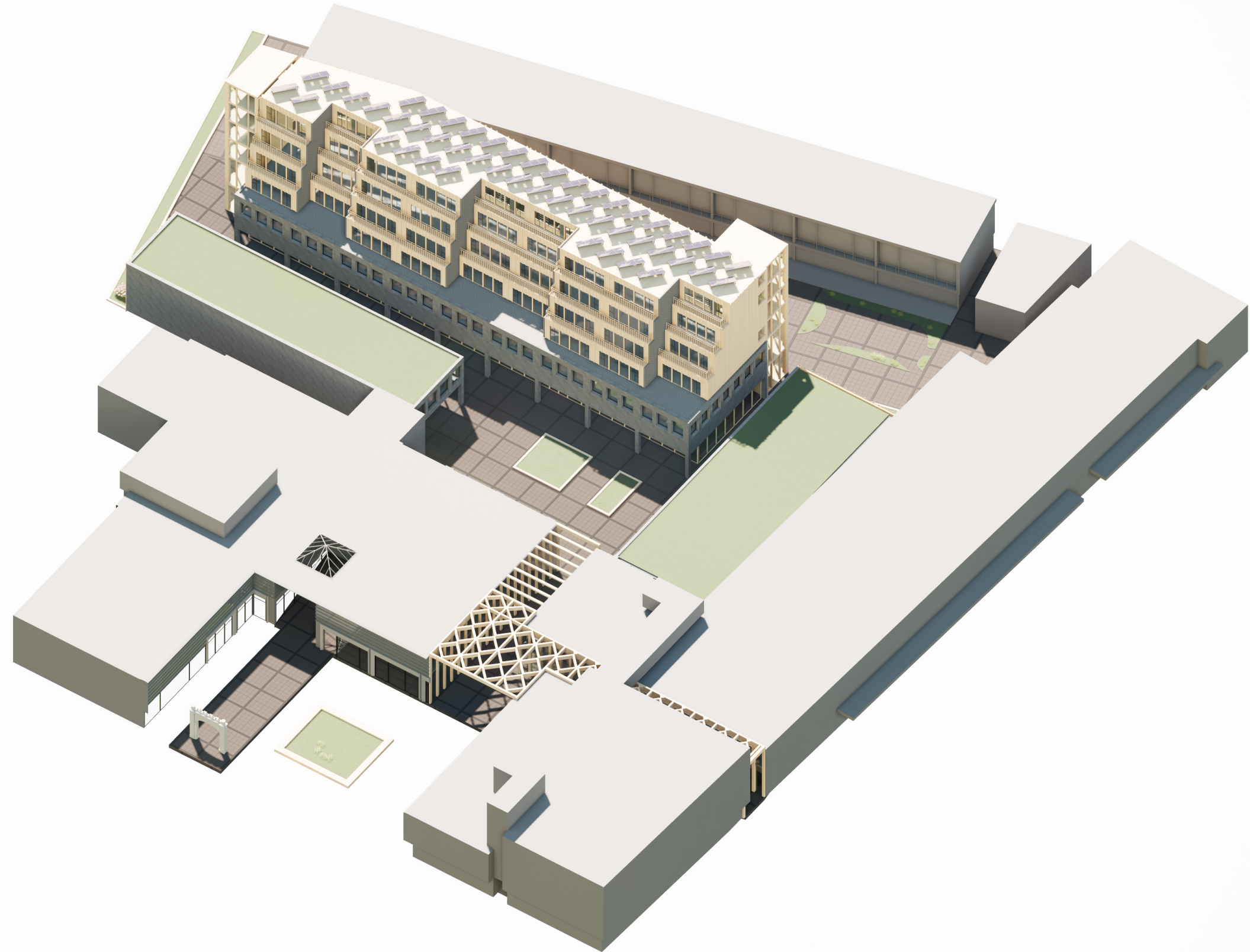

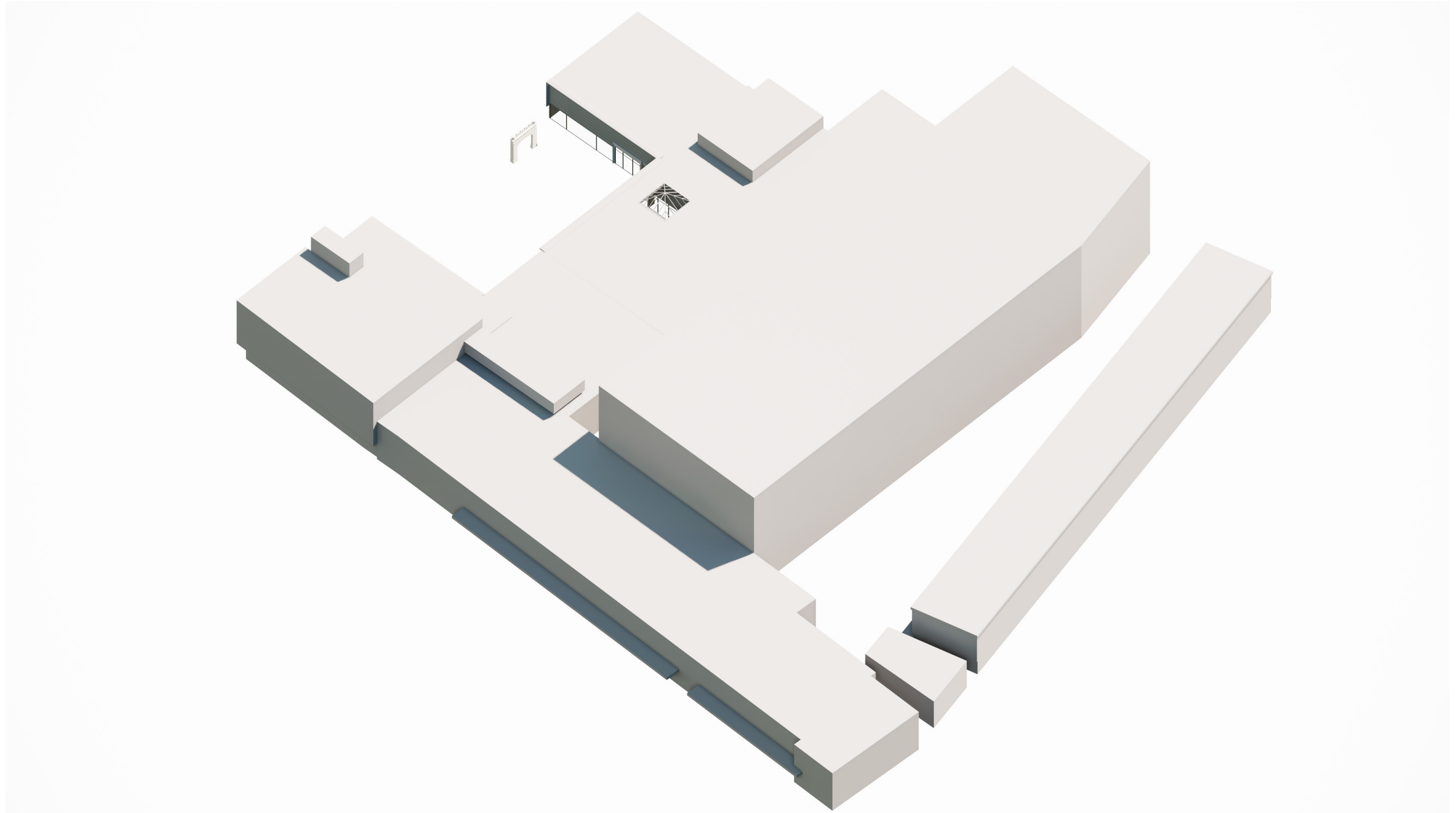



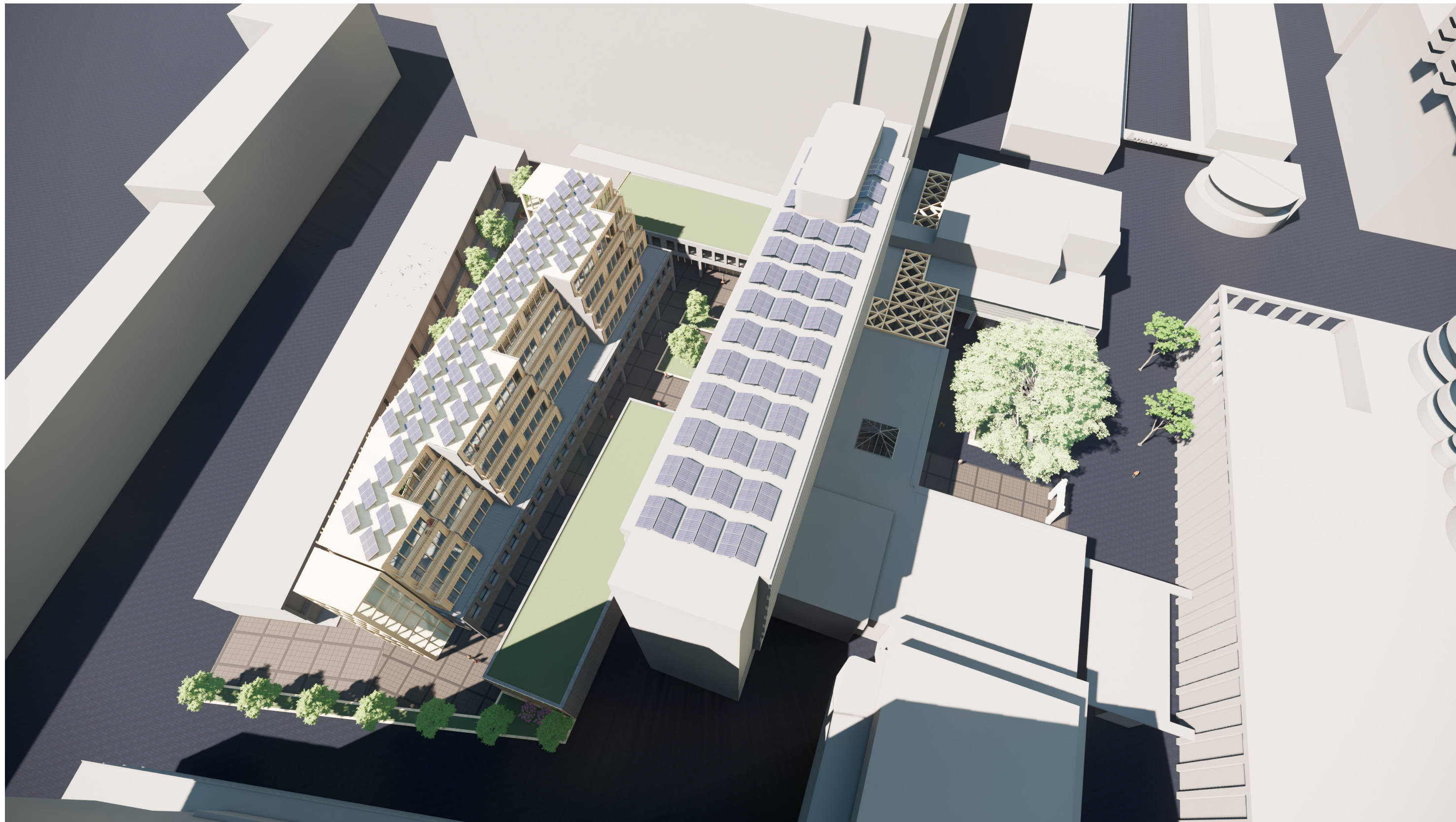

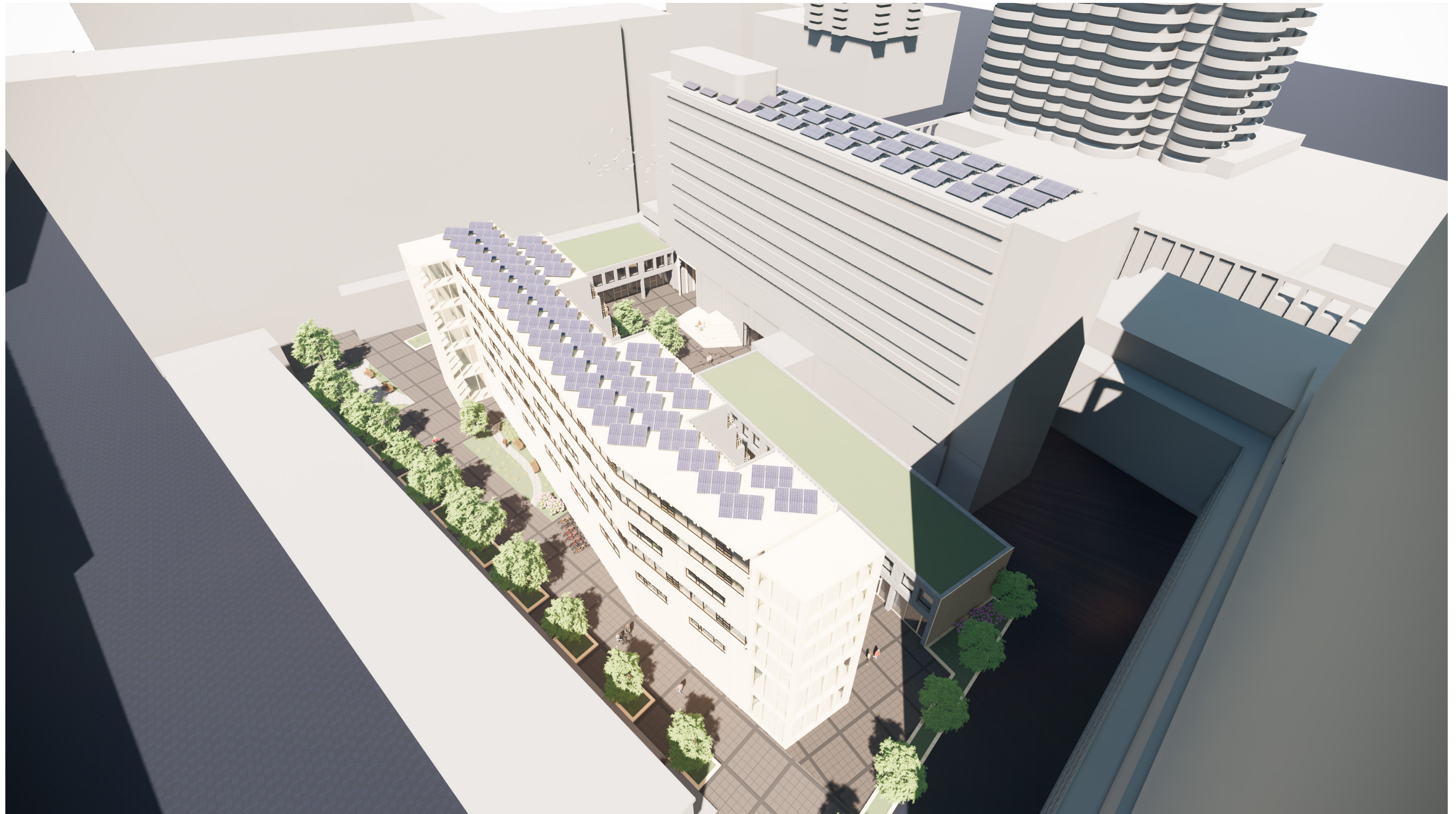





DESIGN

Plans

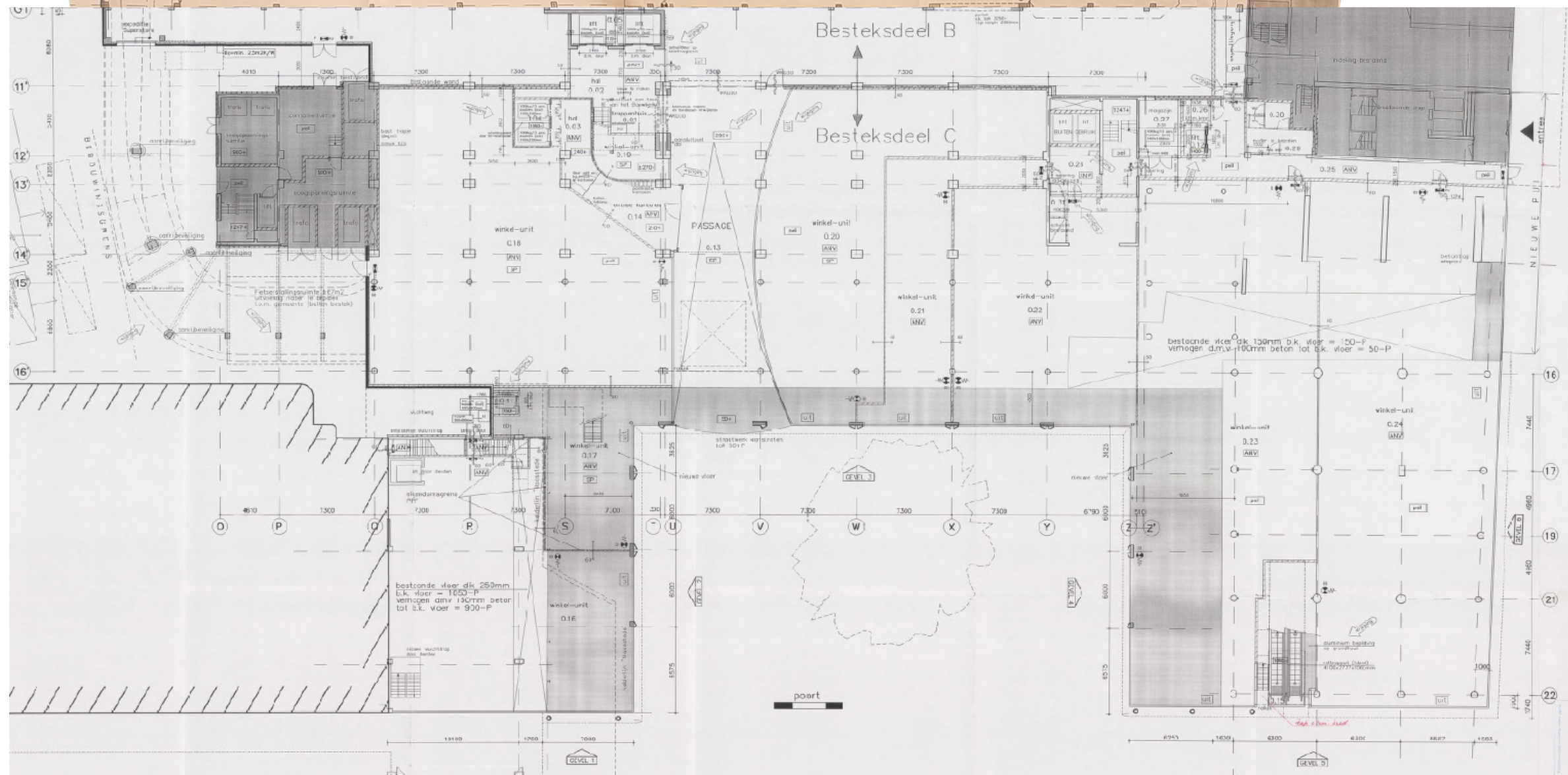

DESIGN

Plans

Ground floor

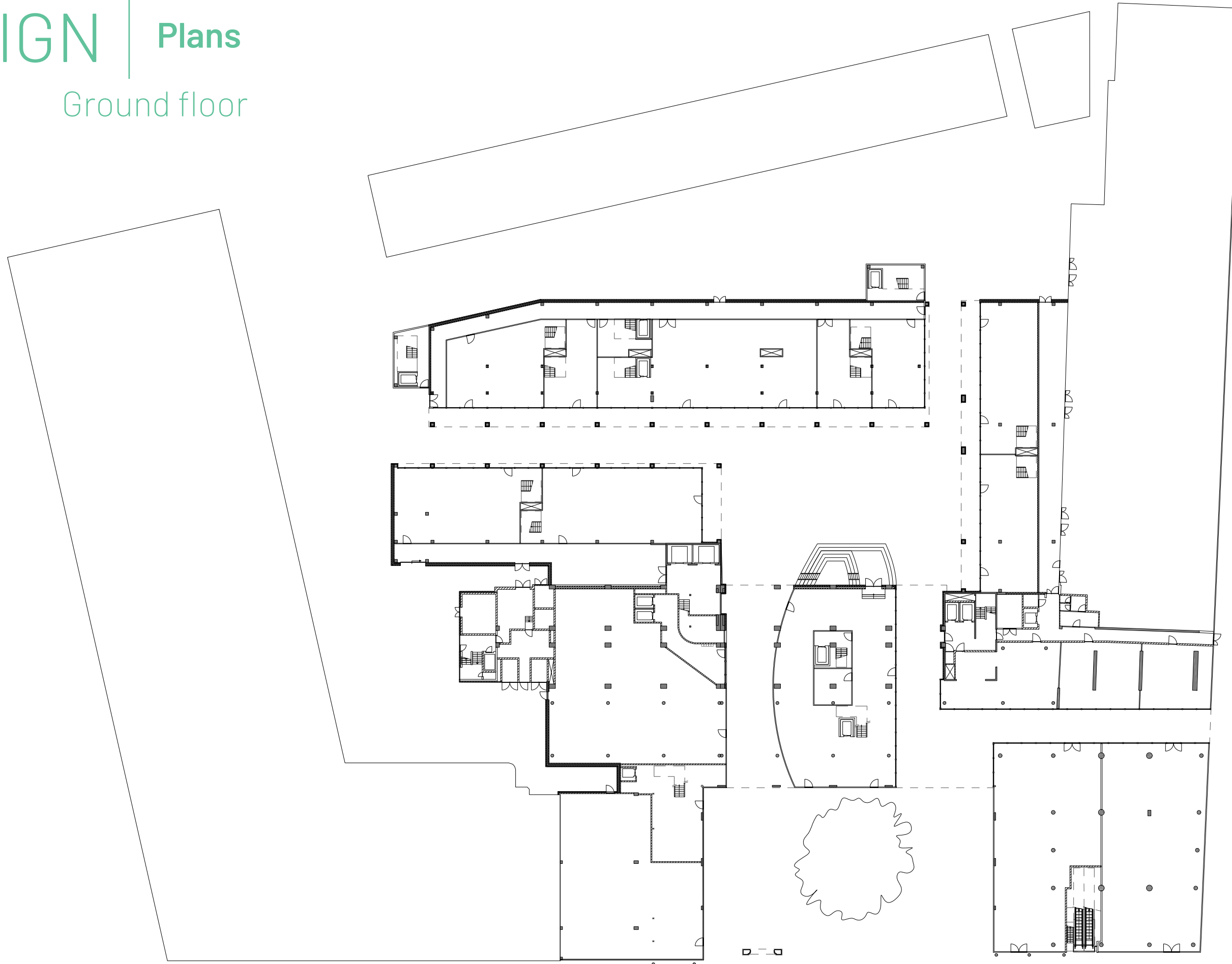

DESIGN

Plans

Ground floor

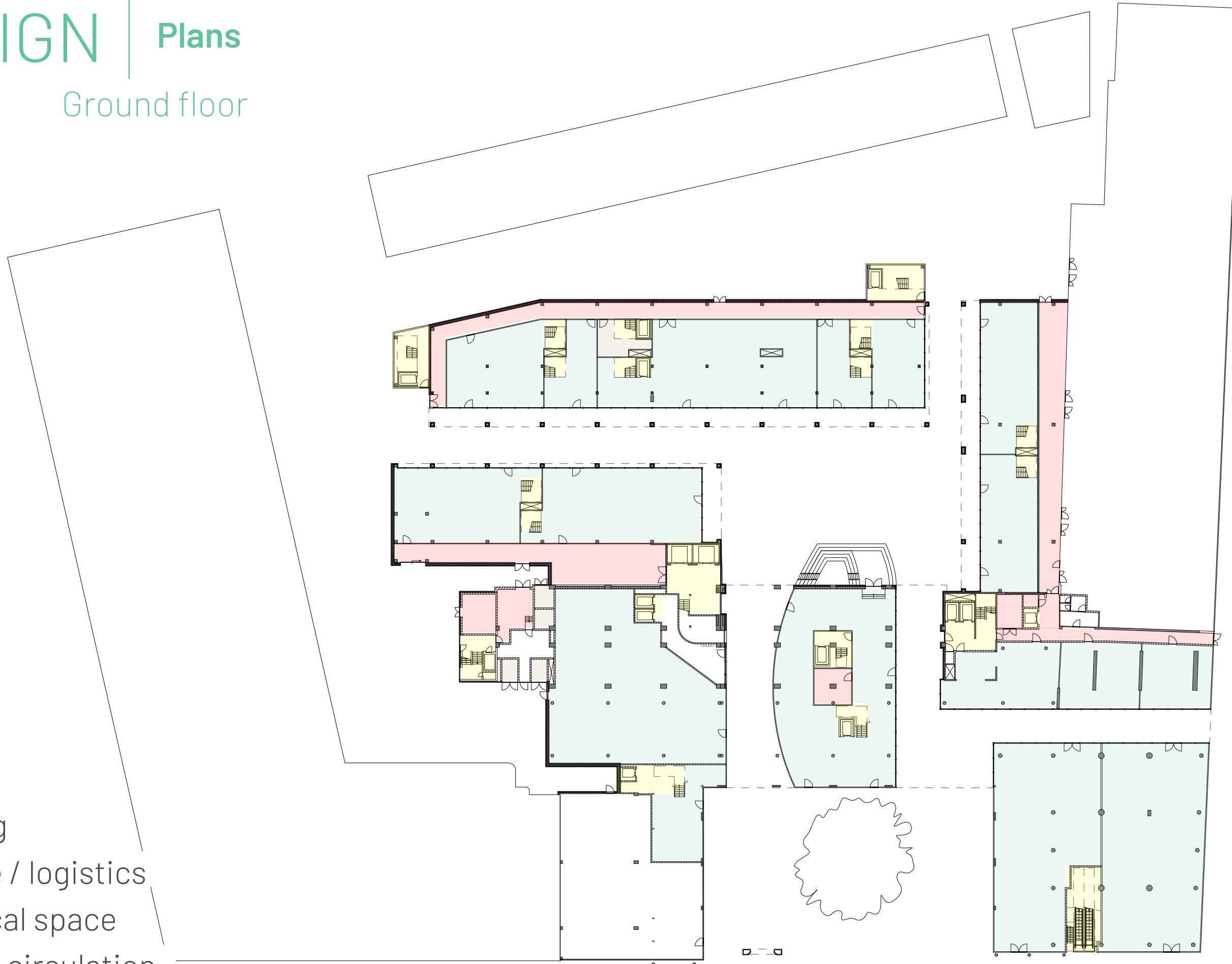

- Retail
- Housing
- Storage / logistics
- Technical space
- Vertical circulation

DESIGN

Plans

First floor

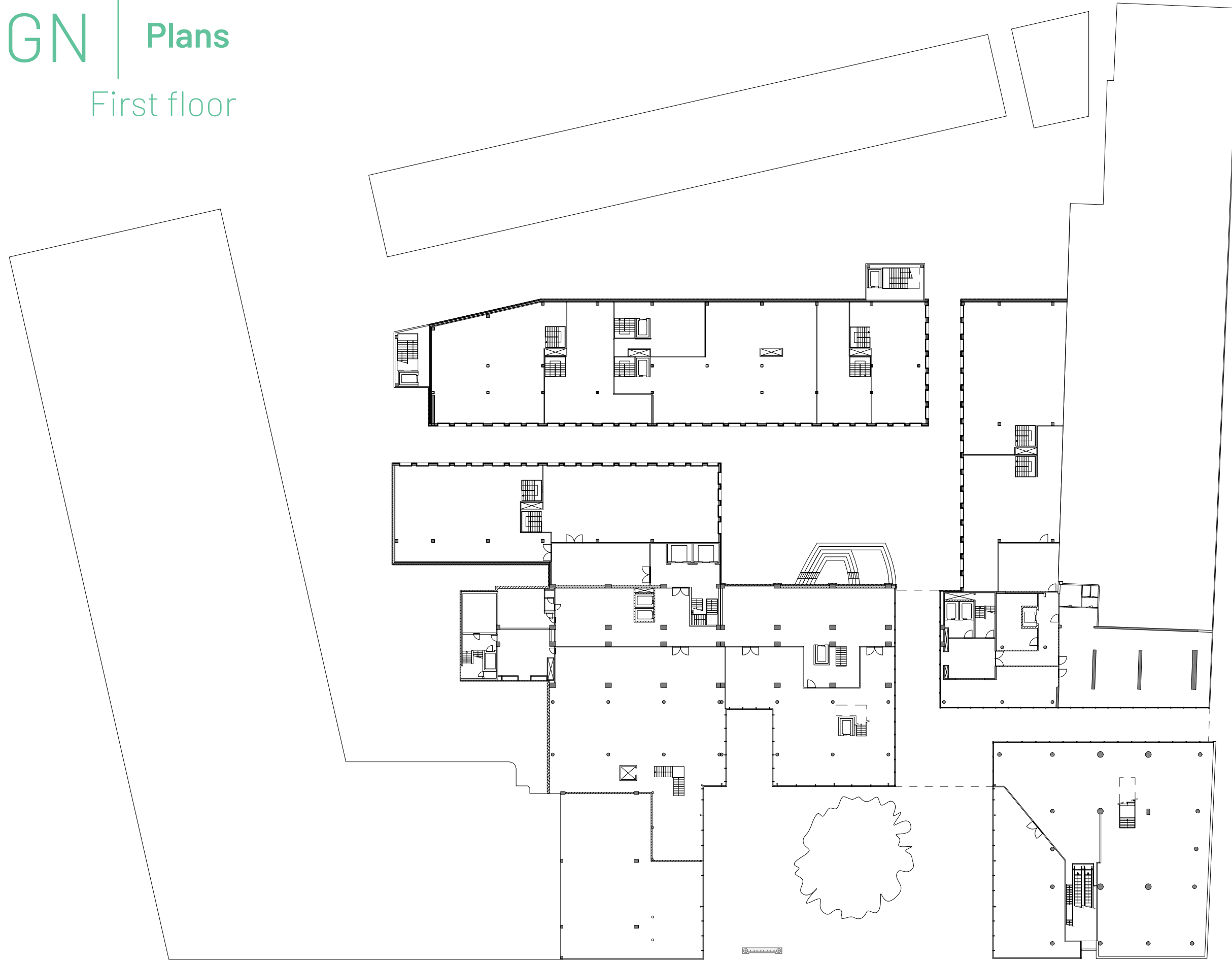



DESIGN

Plans

First floor

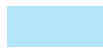

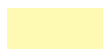
-  Retail
-  Housing
-  Storage / logistics
-  Technical space
-  Vertical circulation

DESIGN

Plans

Second floor

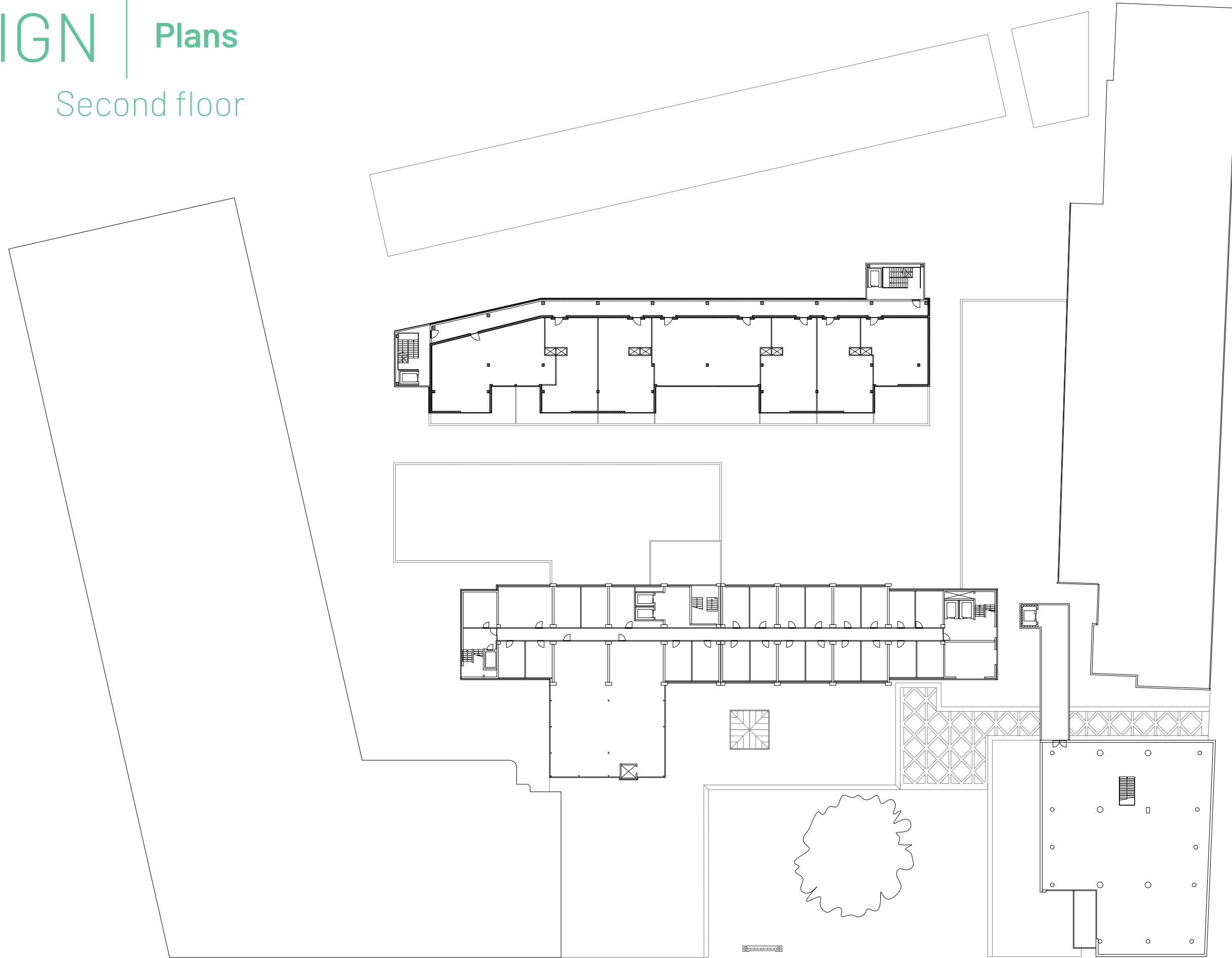

DESIGN

Plans

Second floor

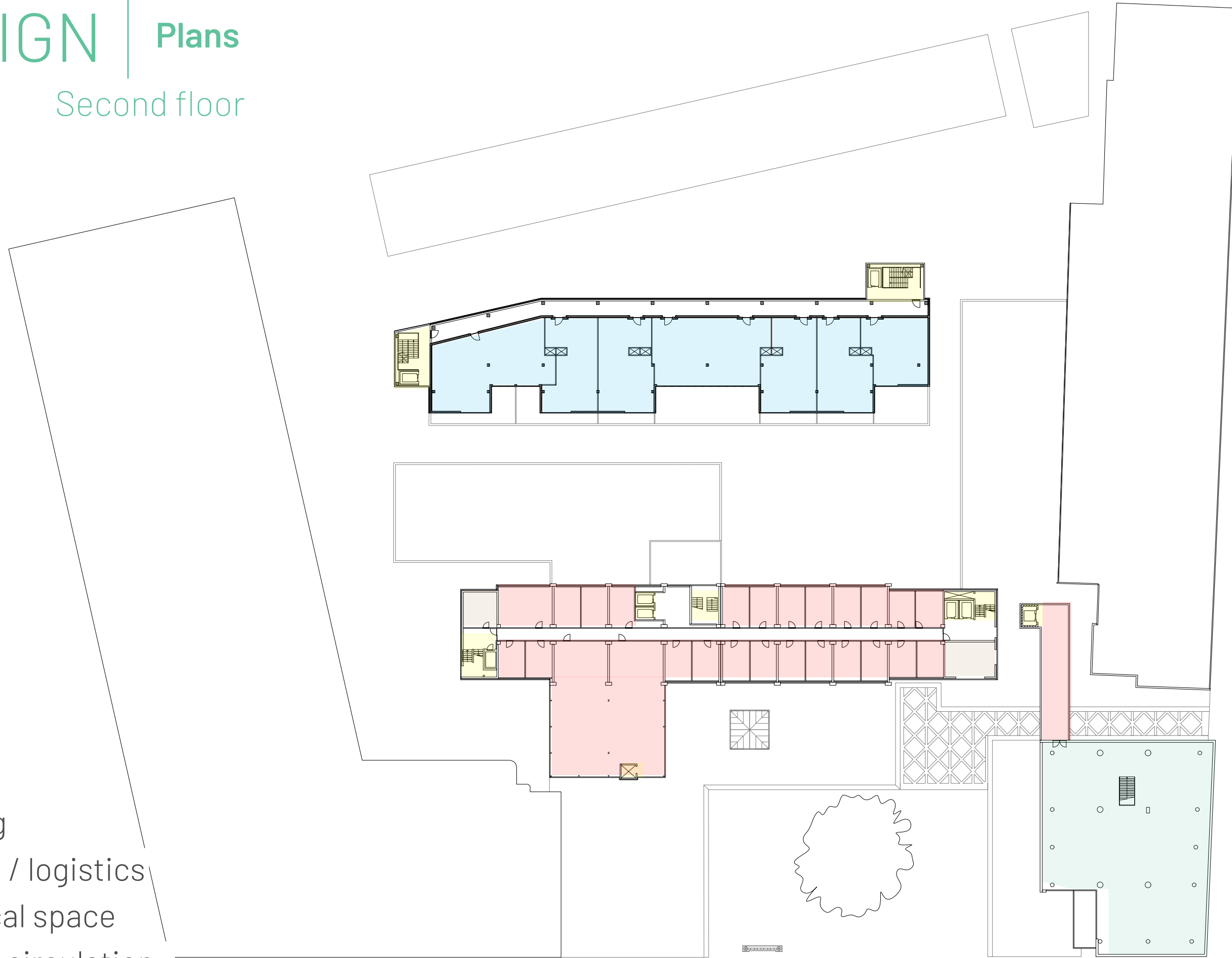

- Retail
- Housing
- Storage / logistics
- Technical space
- Vertical circulation

DESIGN | Plans

Third floor

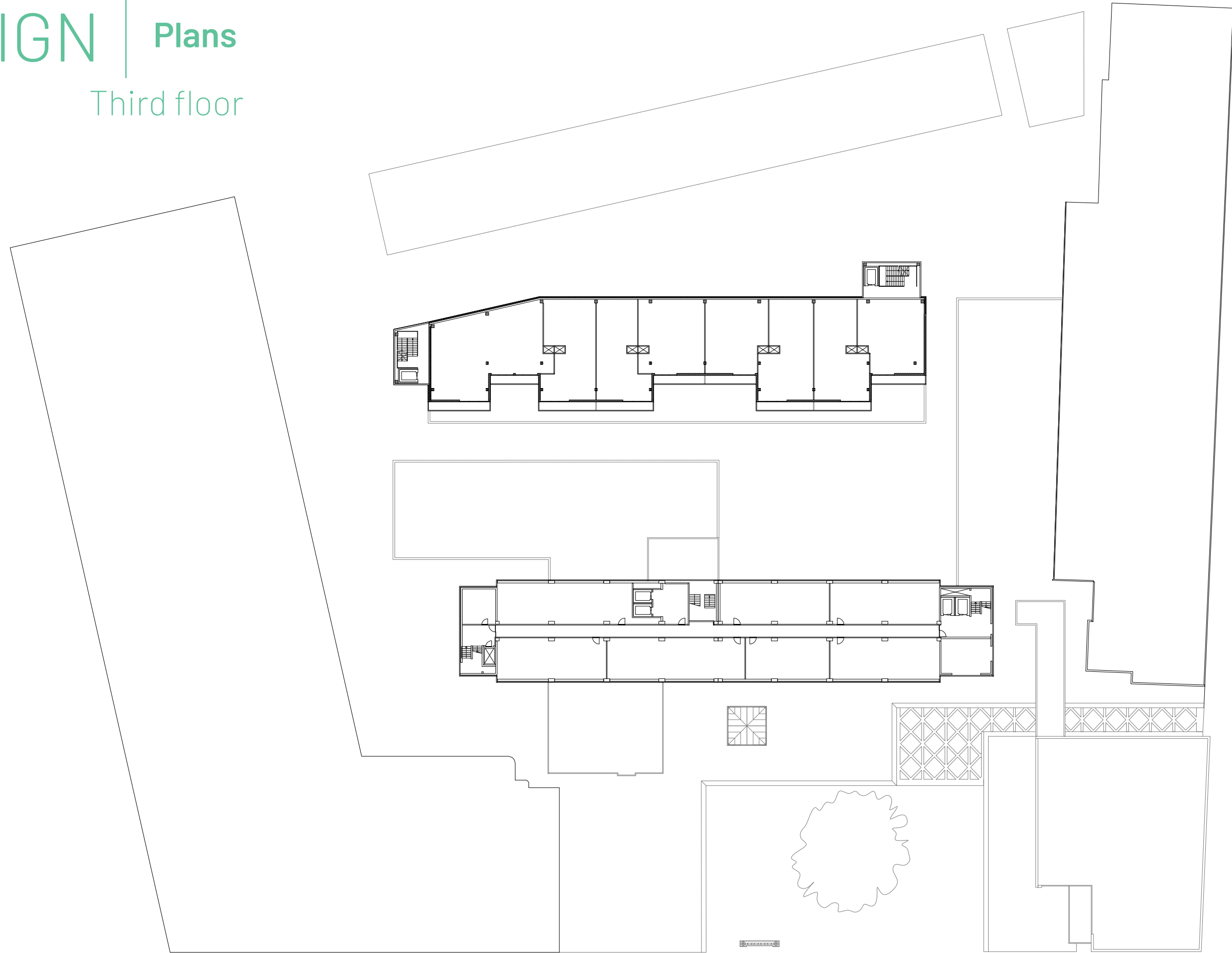

DESIGN

Plans

Third floor



- Retail
- Housing
- Storage / logistics
- Technical space
- Vertical circulation

DESIGN

Plans

Fourth floor

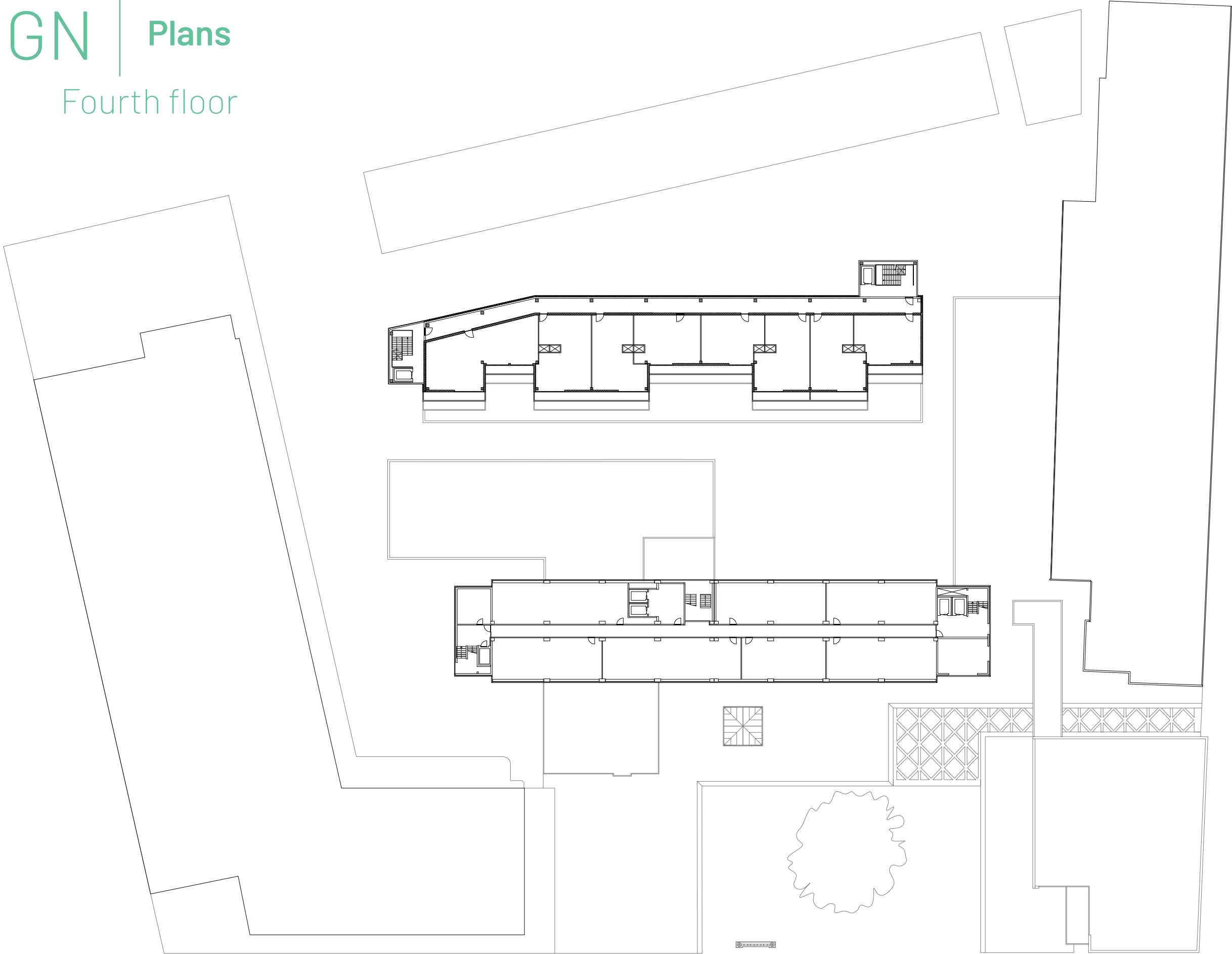

DESIGN | Plans

Fourth floor

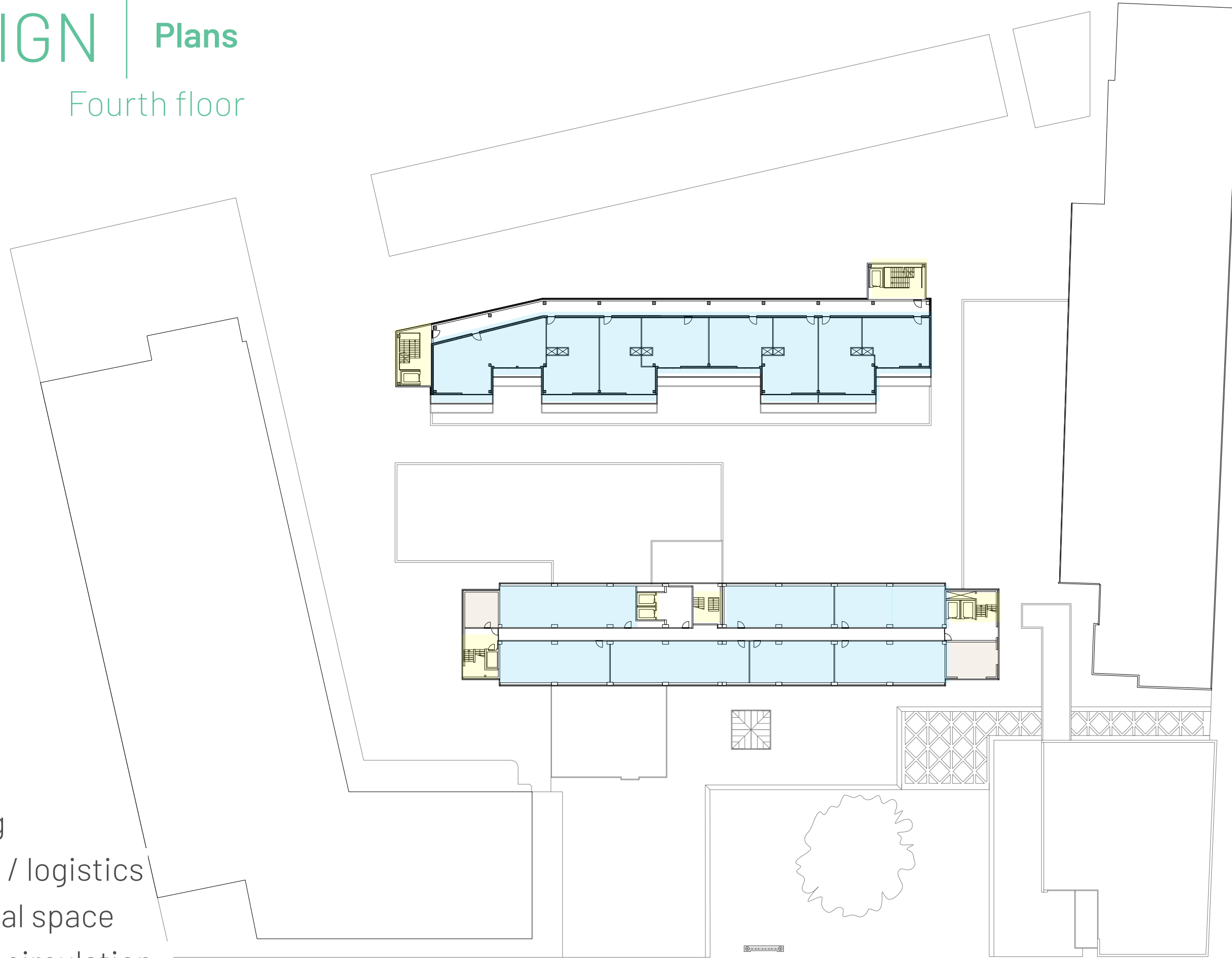

- Retail
- Housing
- Storage / logistics
- Technical space
- Vertical circulation

DESIGN

Plans

Fifth floor

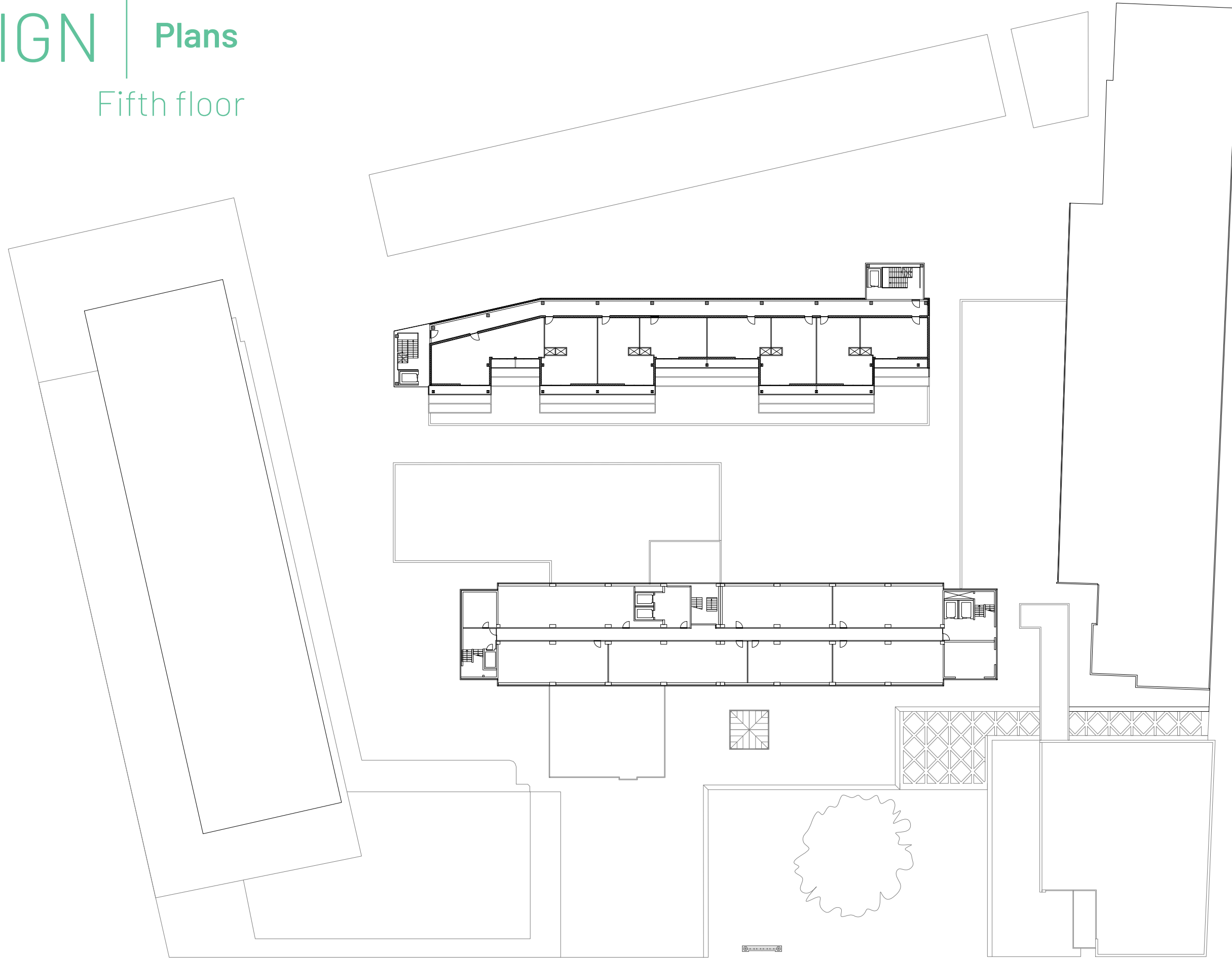

DESIGN

Plans

Fifth floor

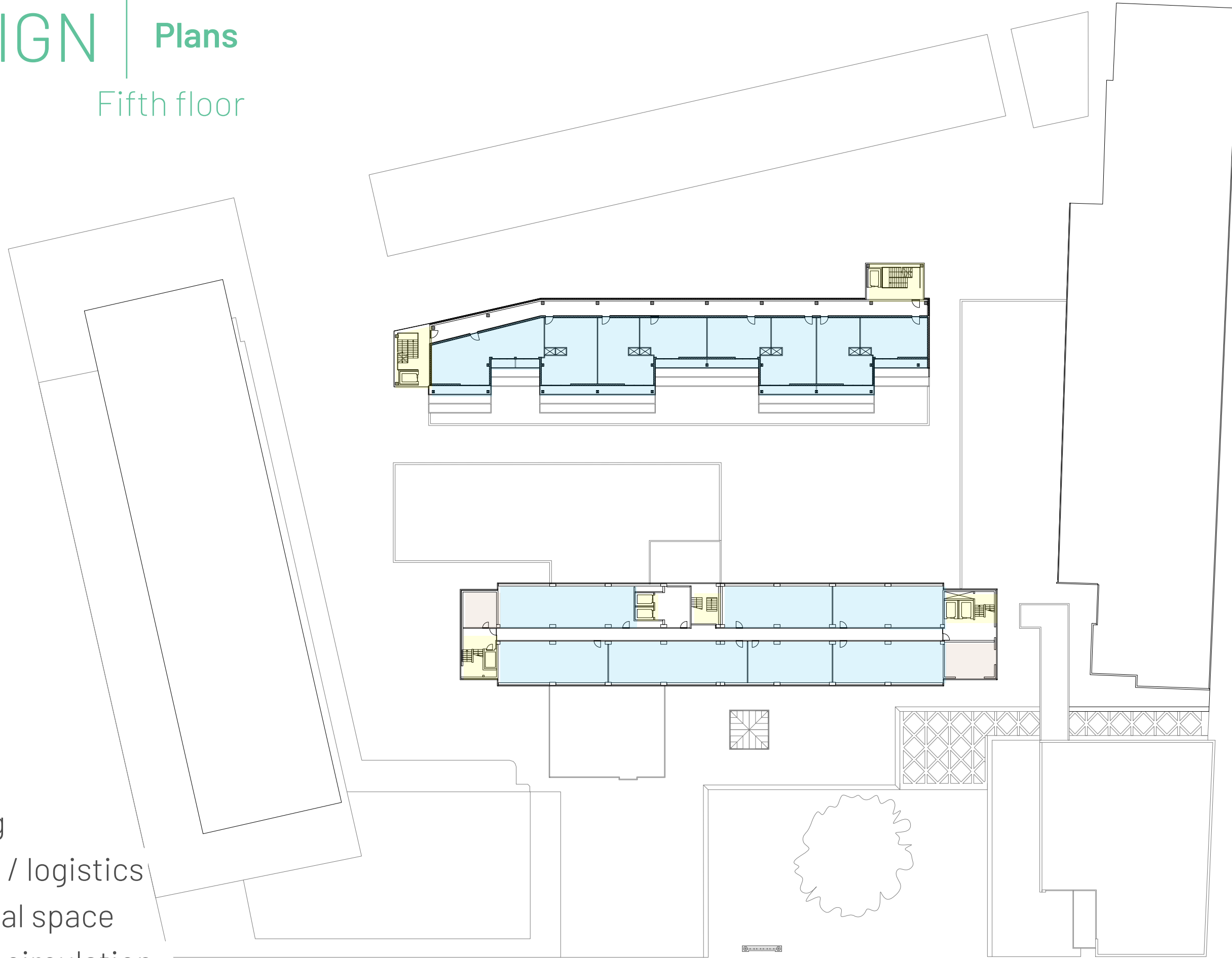

- Retail
- Housing
- Storage / logistics
- Technical space
- Vertical circulation

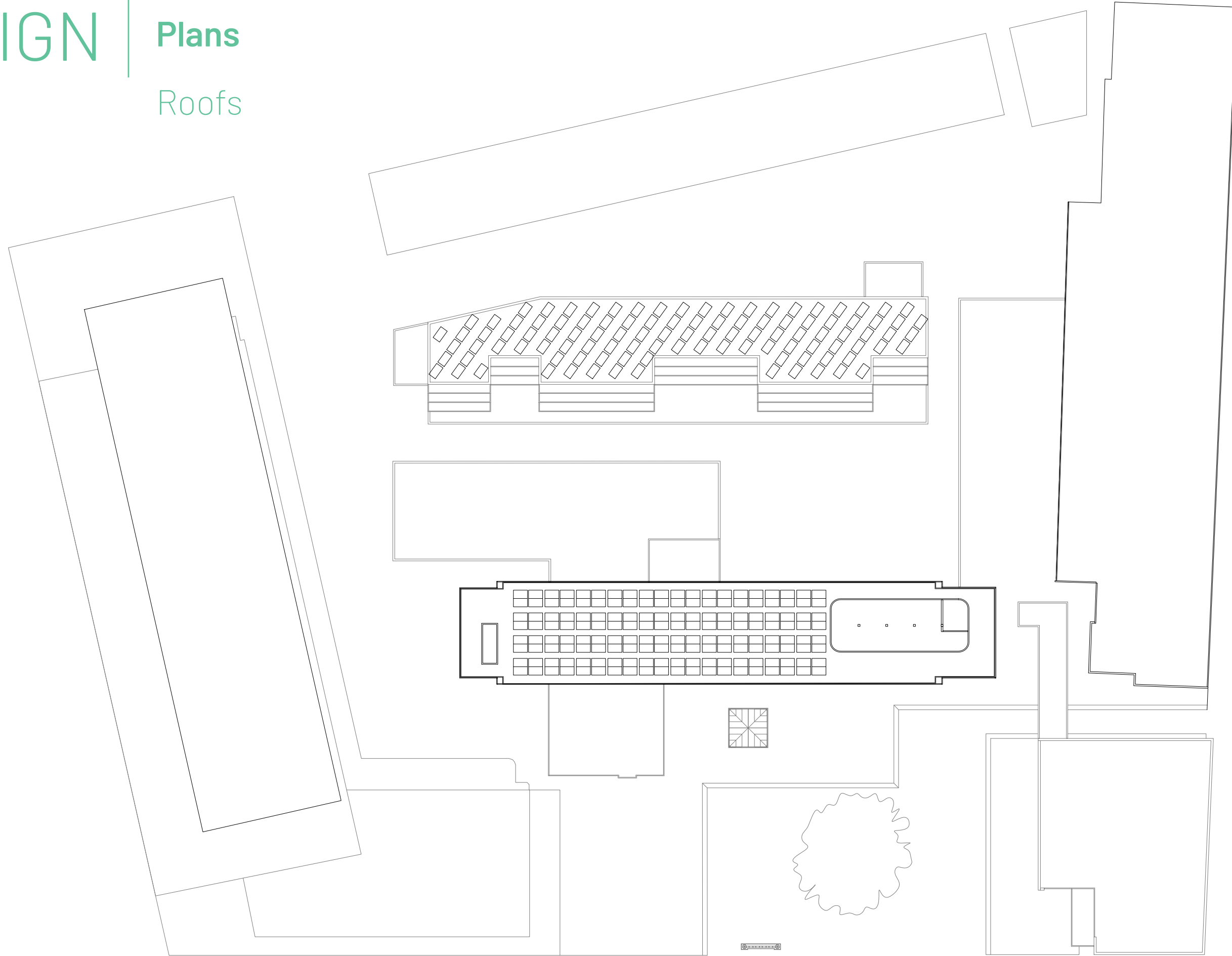



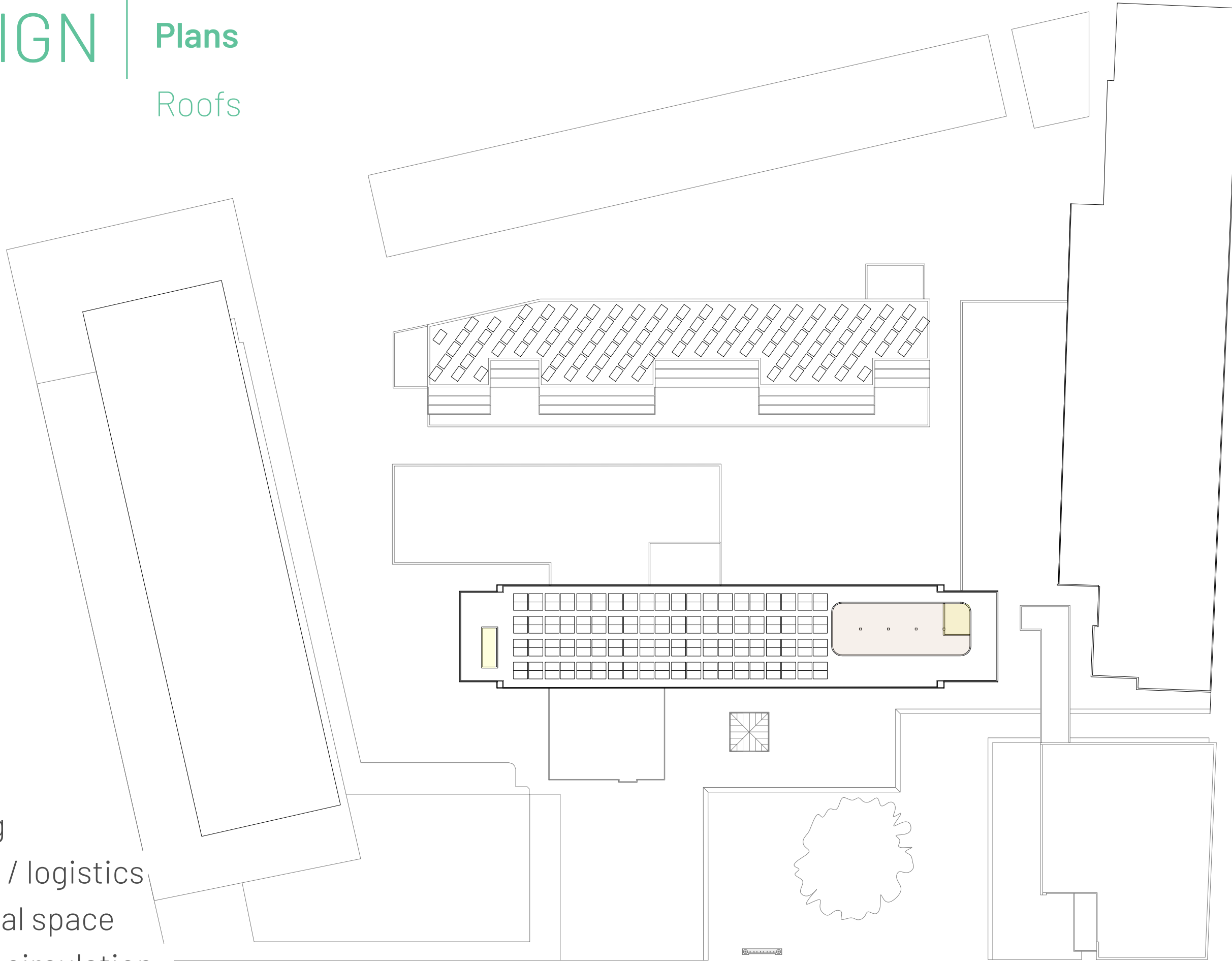

DESIGN

Plans

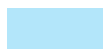
Roofs



-  Retail
-  Housing
-  Storage / logistics
-  Technical space
-  Vertical circulation

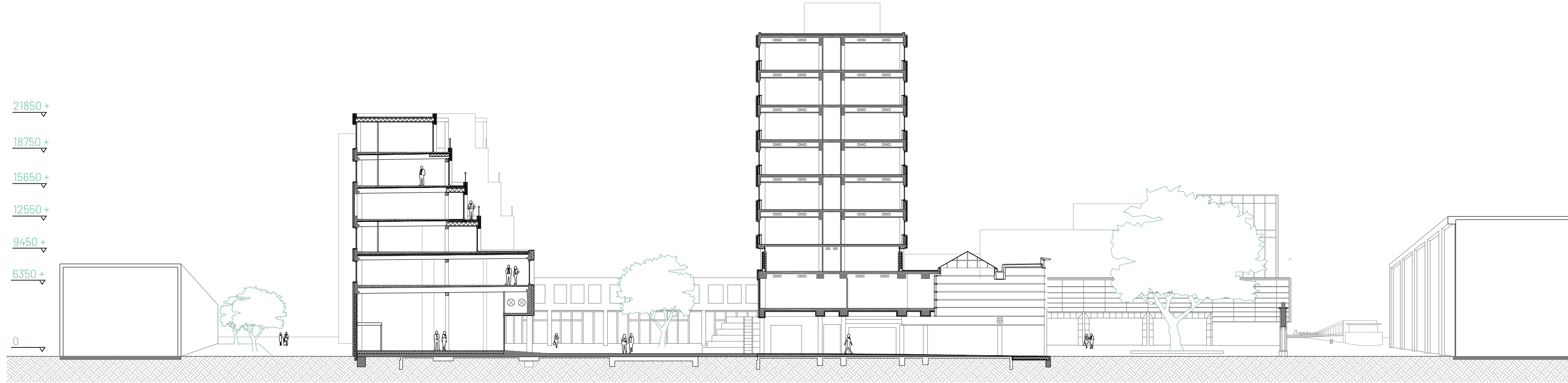
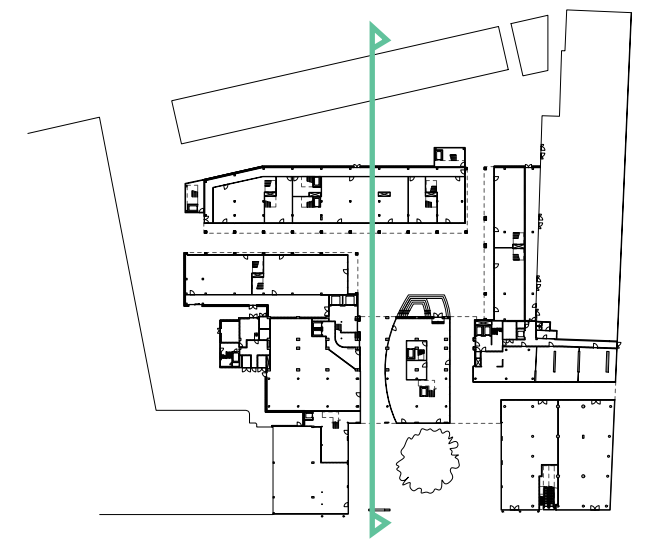



- Retail
- Storage / logistics
- Housing
- Technical space
- Vertical circulation

DESIGN

Sections

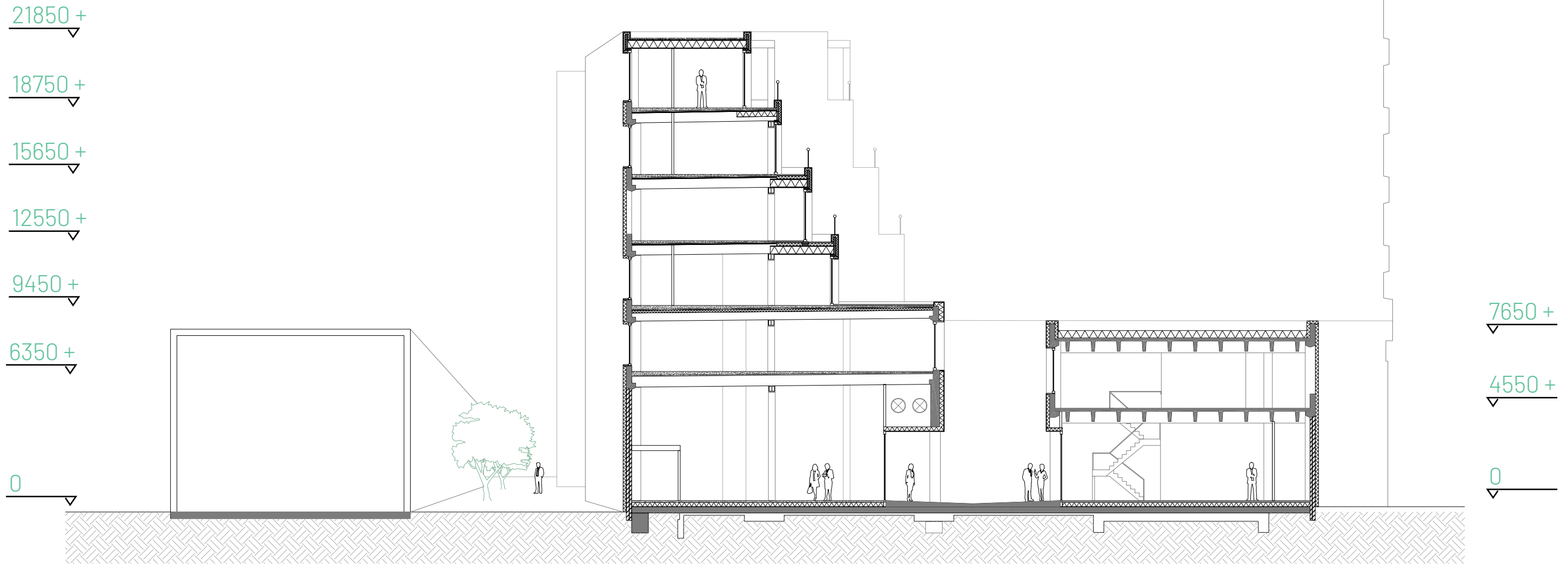
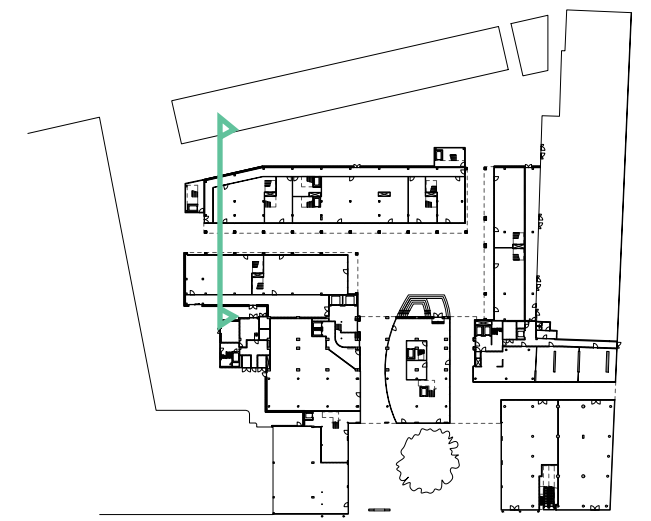

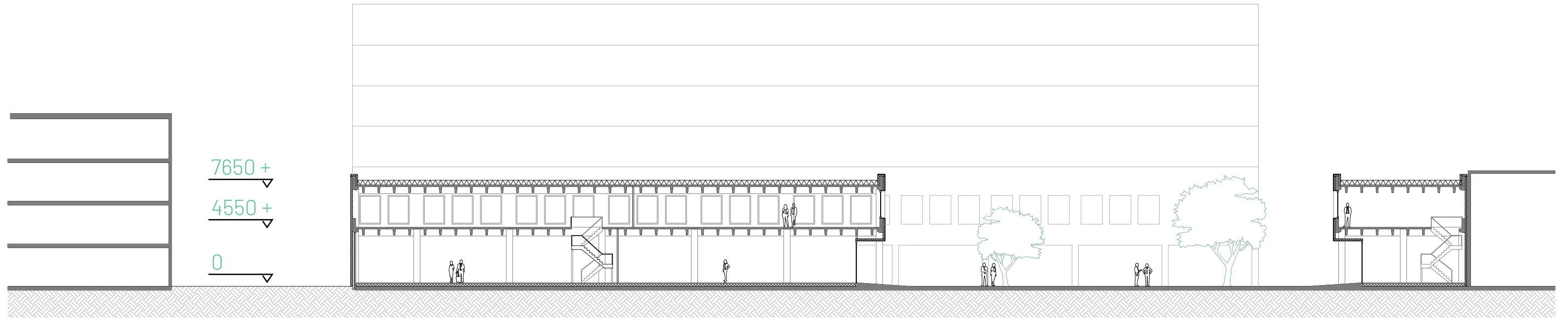
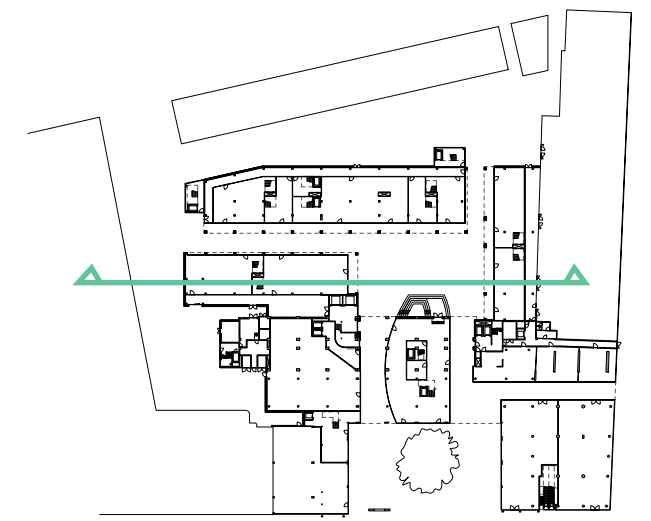

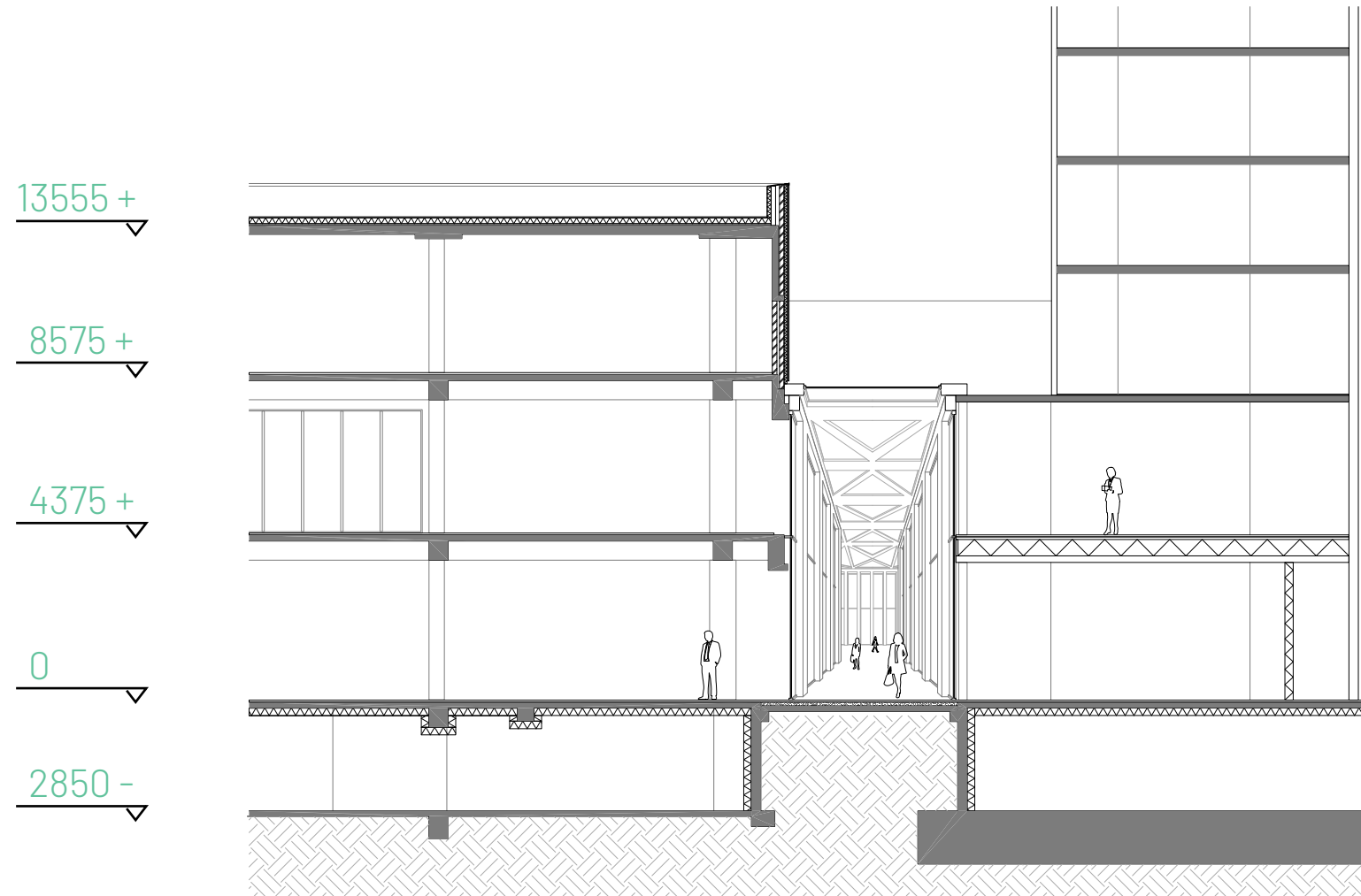
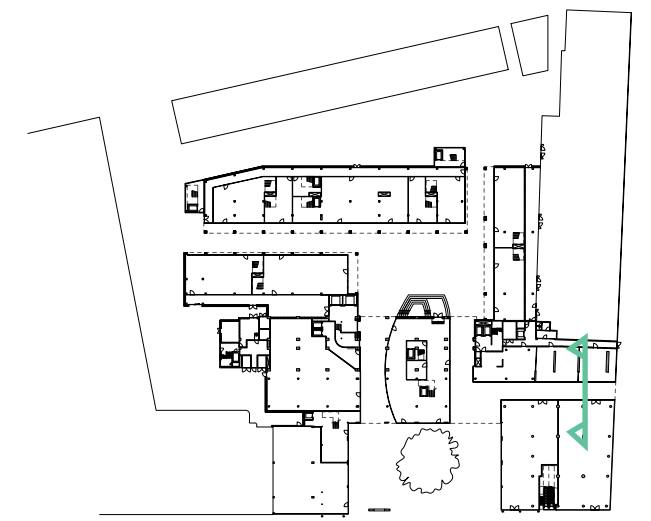

DESIGN

Elevations Square & Building A



Northwest

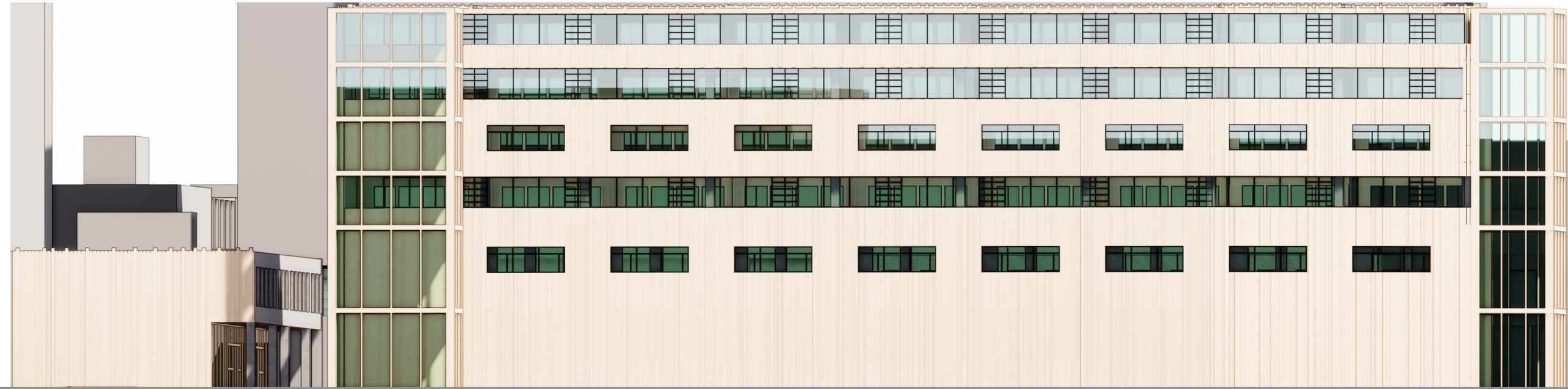

Southwest



Northeast



Square: Northeast

DESIGN

Impressions



DESIGN

Impressions



DESIGN | Impressions



DESIGN

Impressions



DESIGN

Impressions





DESIGN

Impressions



DESIGN

Impressions



DESIGN

Impressions



DESIGN

Impressions



DESIGN

Impressions



DESIGN

Impressions



DESIGN

Impressions



DESIGN

Retail



Ground floor

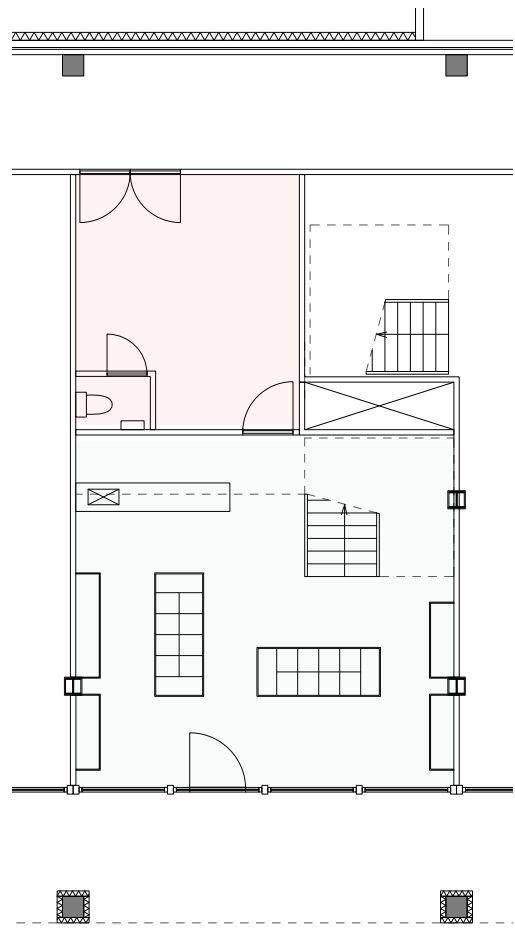

Entresol

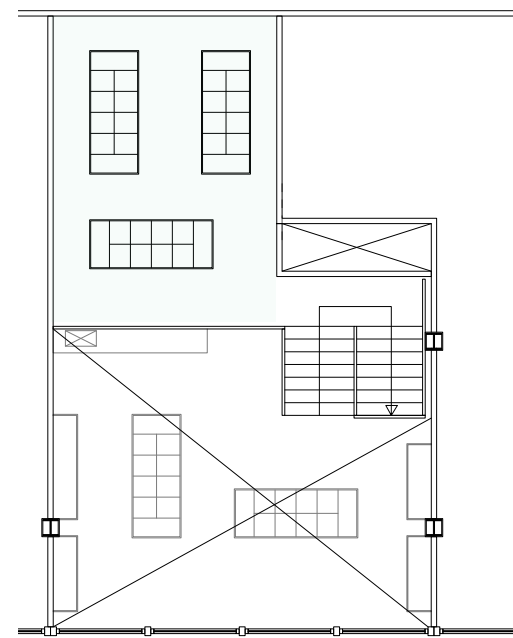

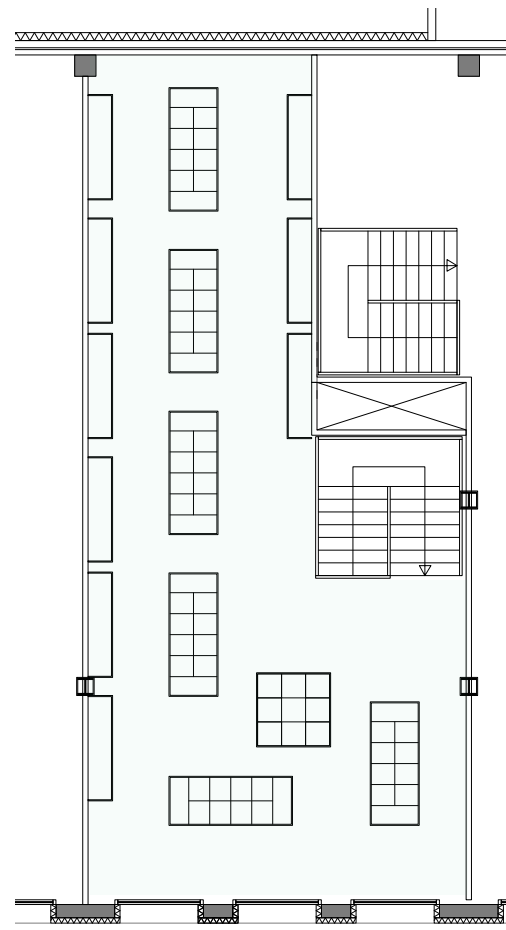

First floor



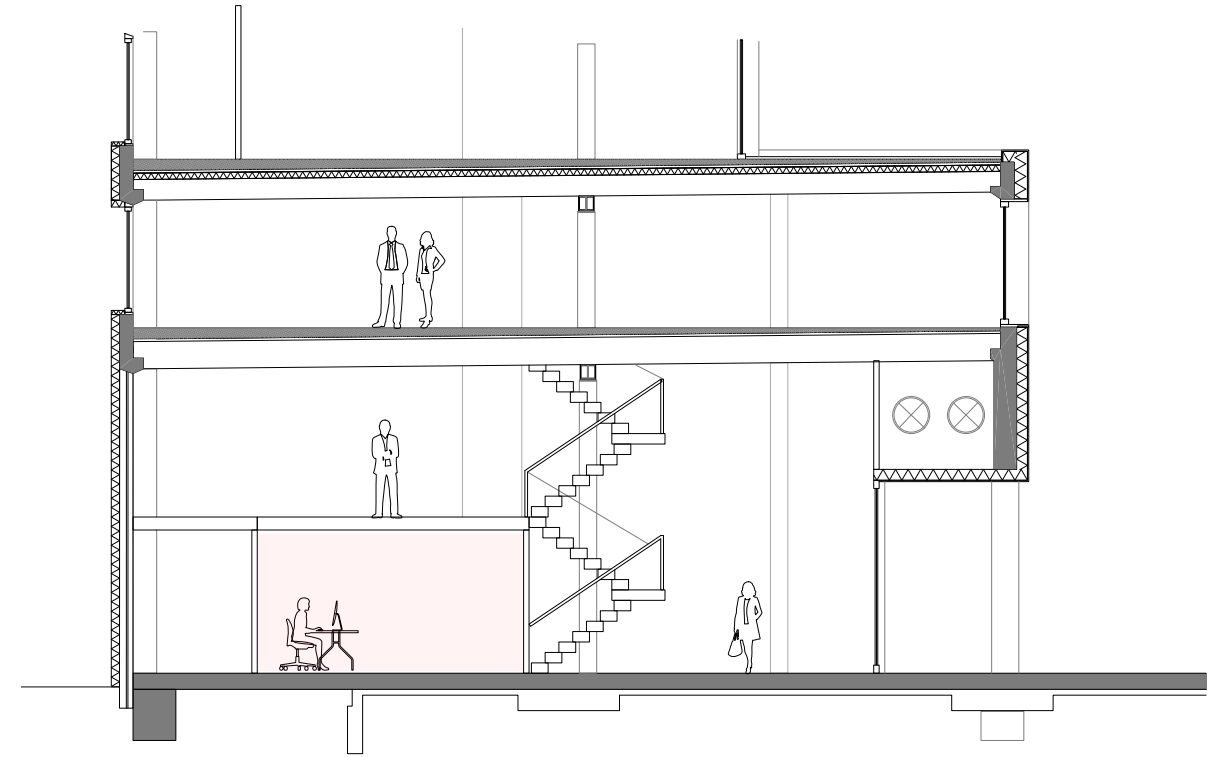

Section

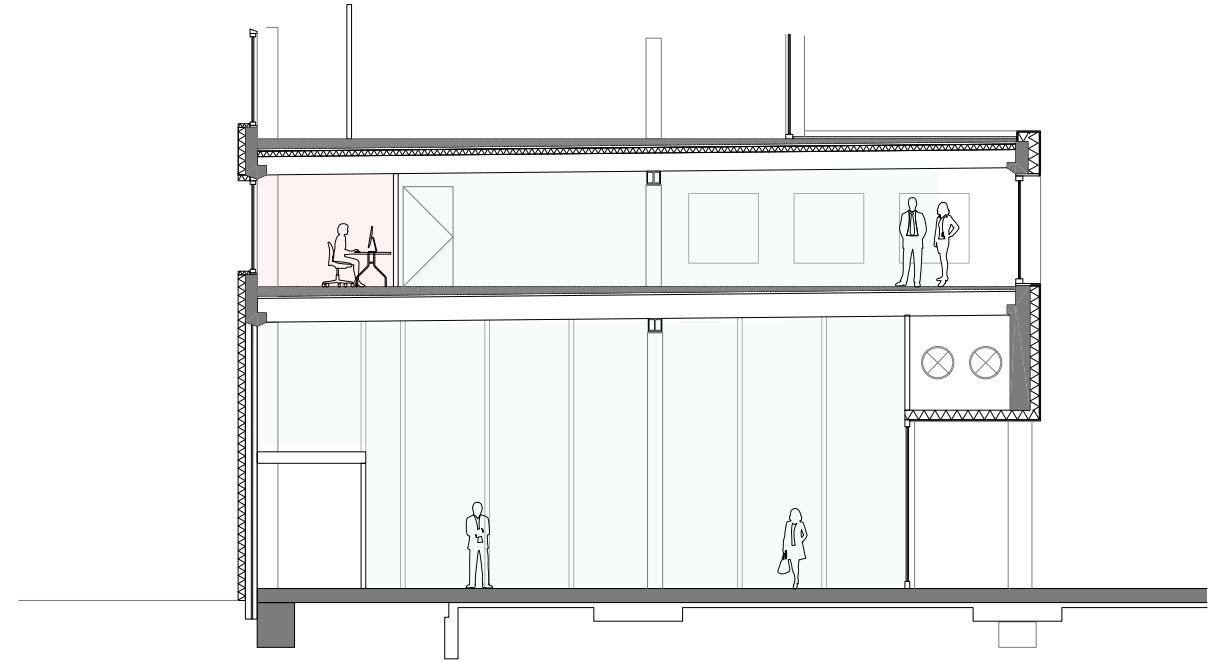
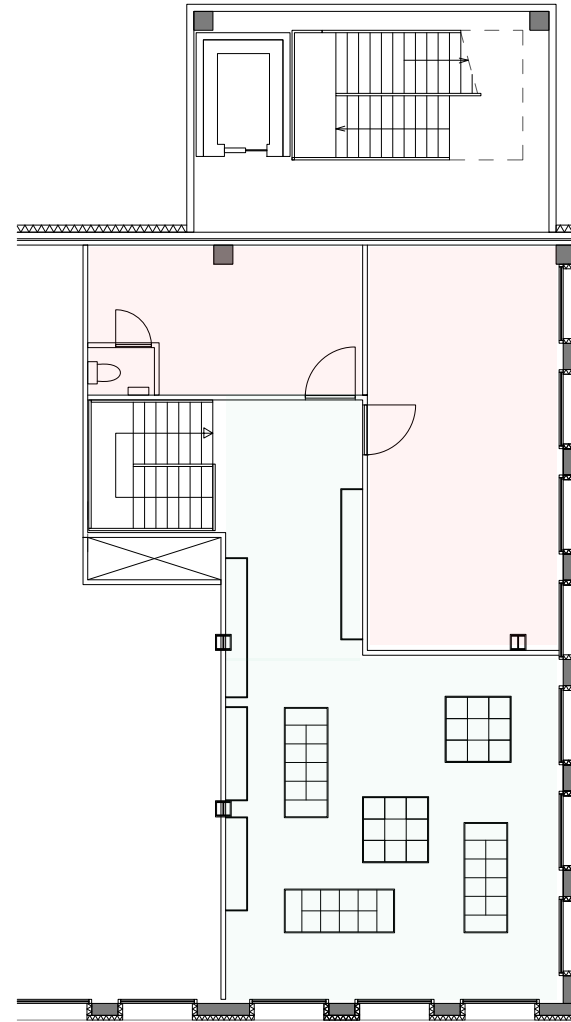
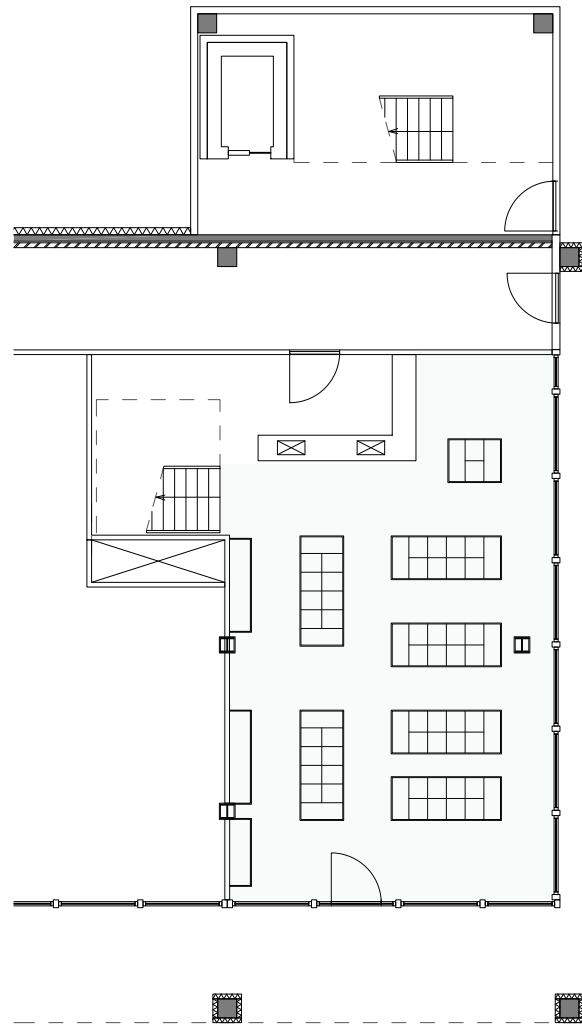

-  Retail 150m²
-  Storage / logistics 20m²



-  Retail 150m²
-  Storage / logistics 20m²

DESIGN

Retail : 2 shops next to each other

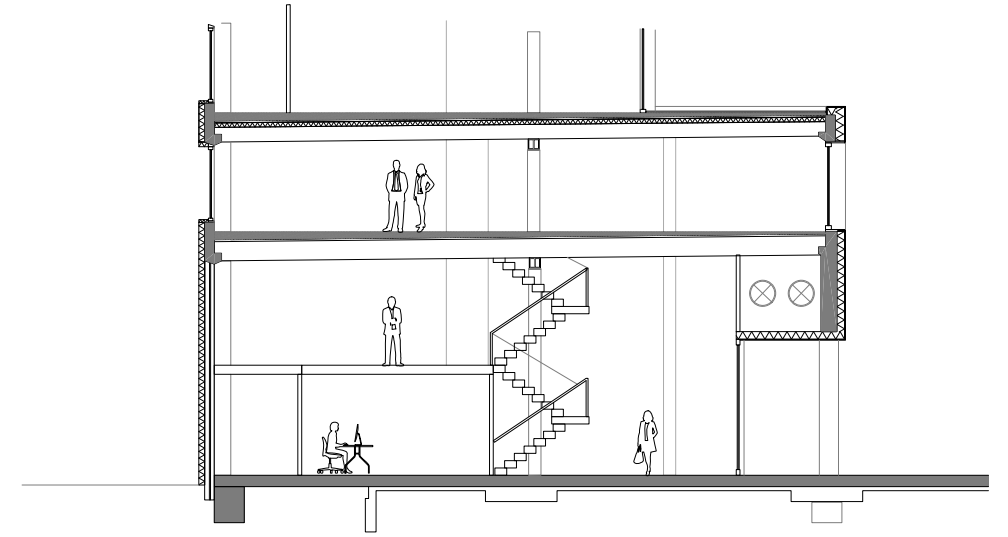
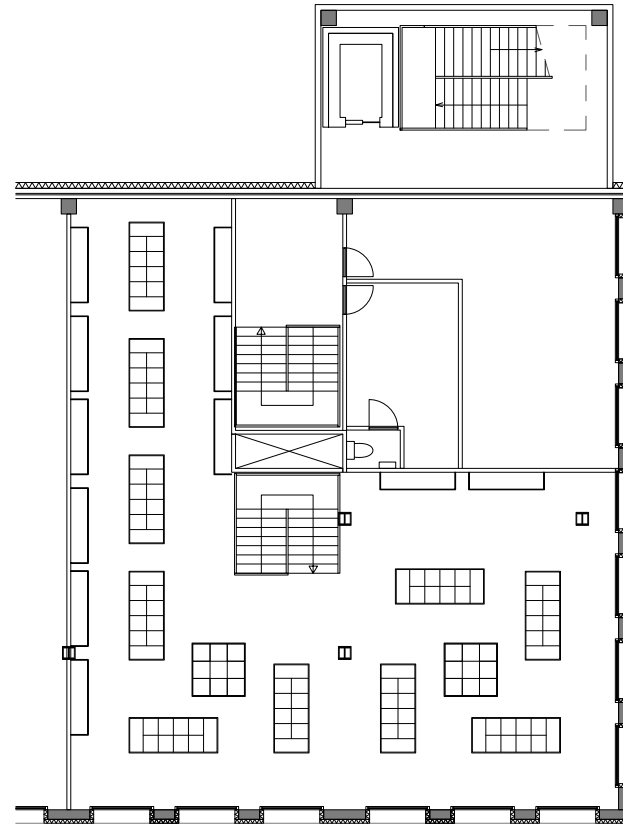
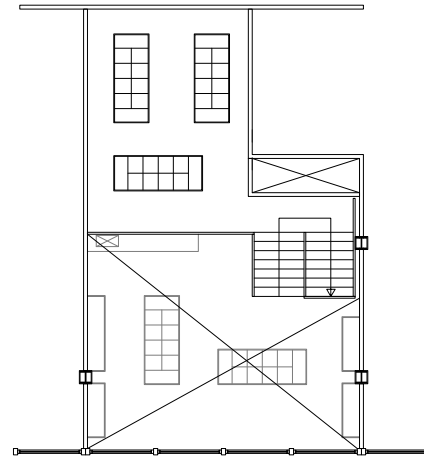
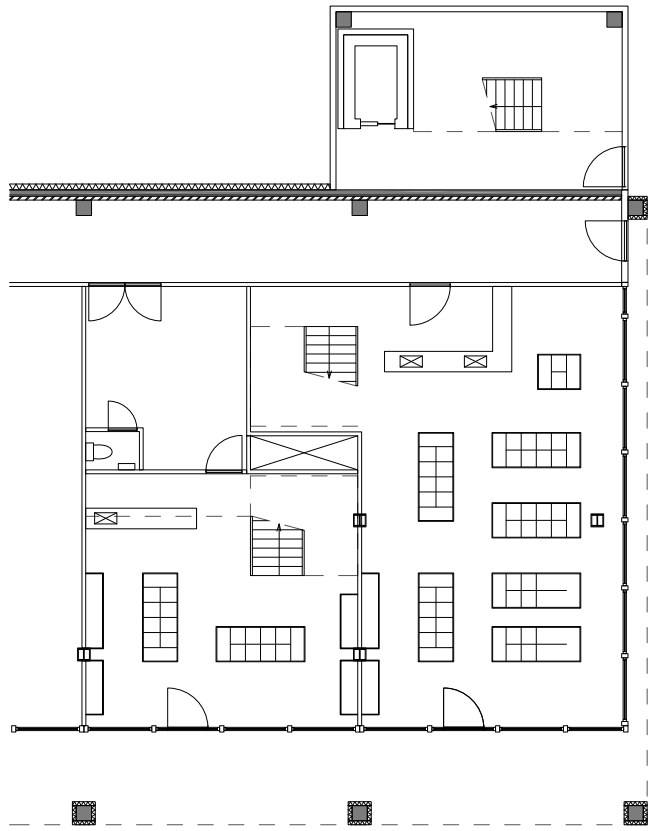

DESIGN

Housing in tower, 150 m2 maisonette

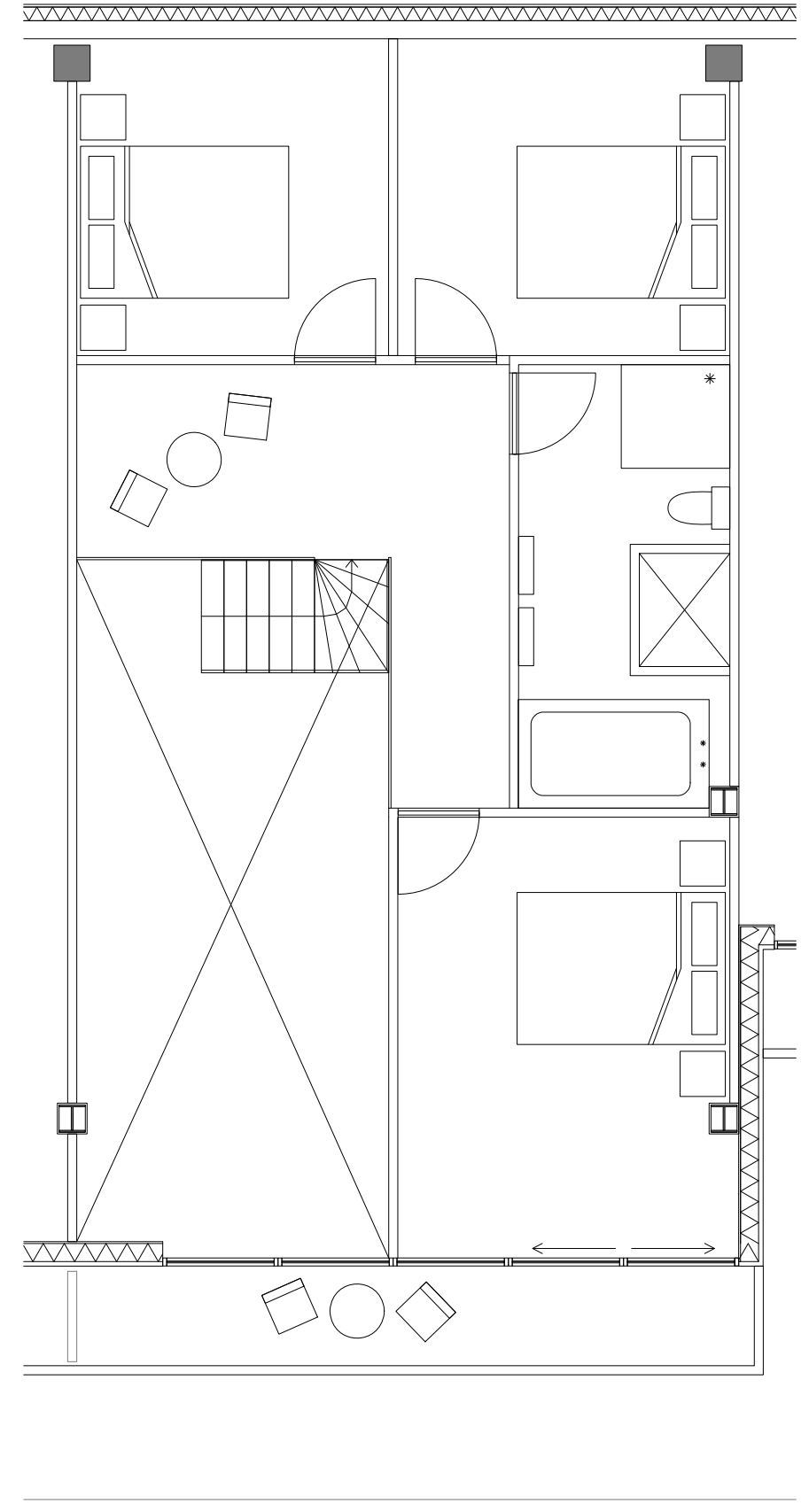
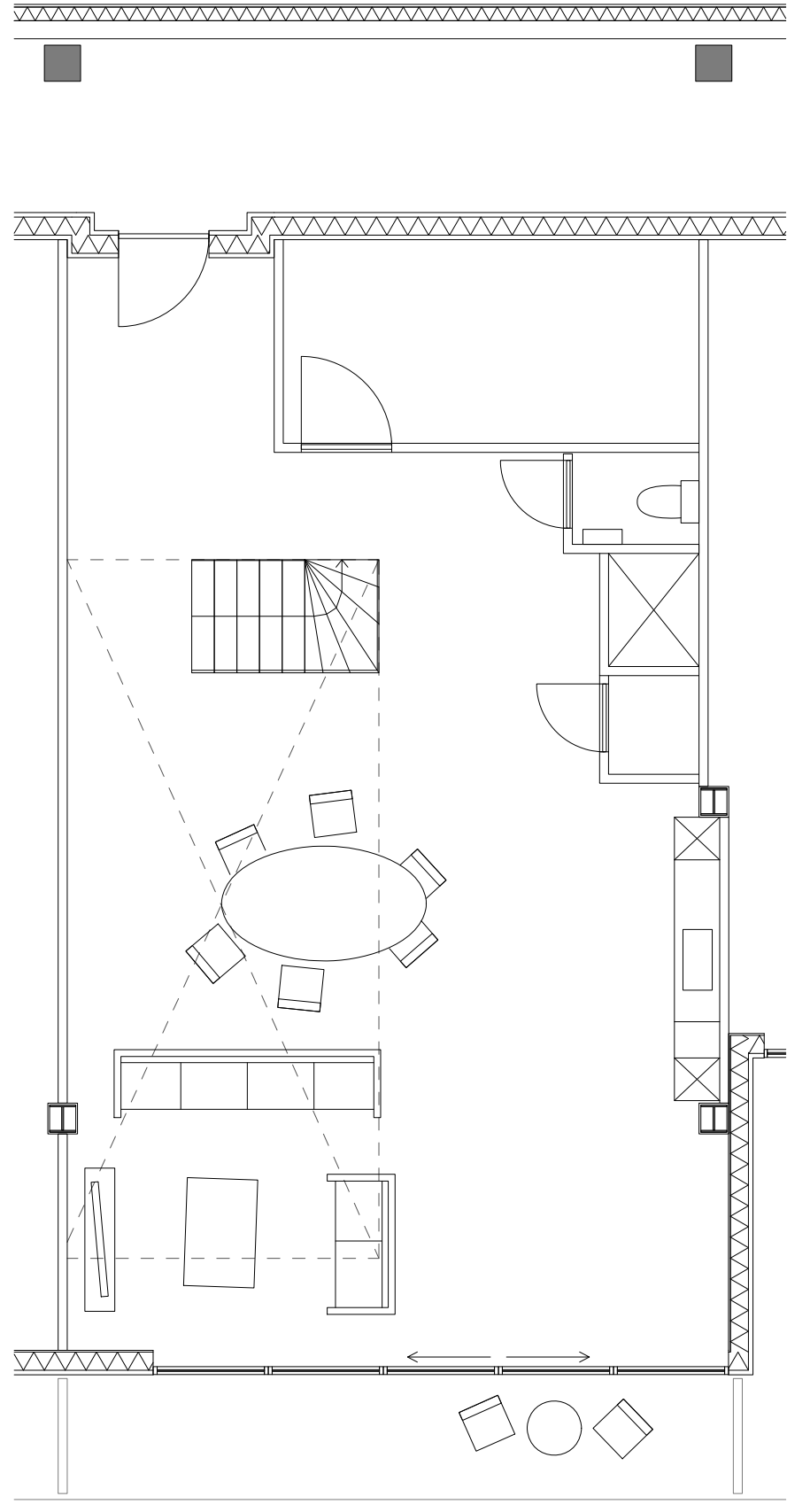

DESIGN

Housing in tower, 50 m2 studio



- 10 m2 Bathroom
- 15 m2 Kitchen & eating area
- 25 m2 Living & bedroom
- 8 m2 Balcony

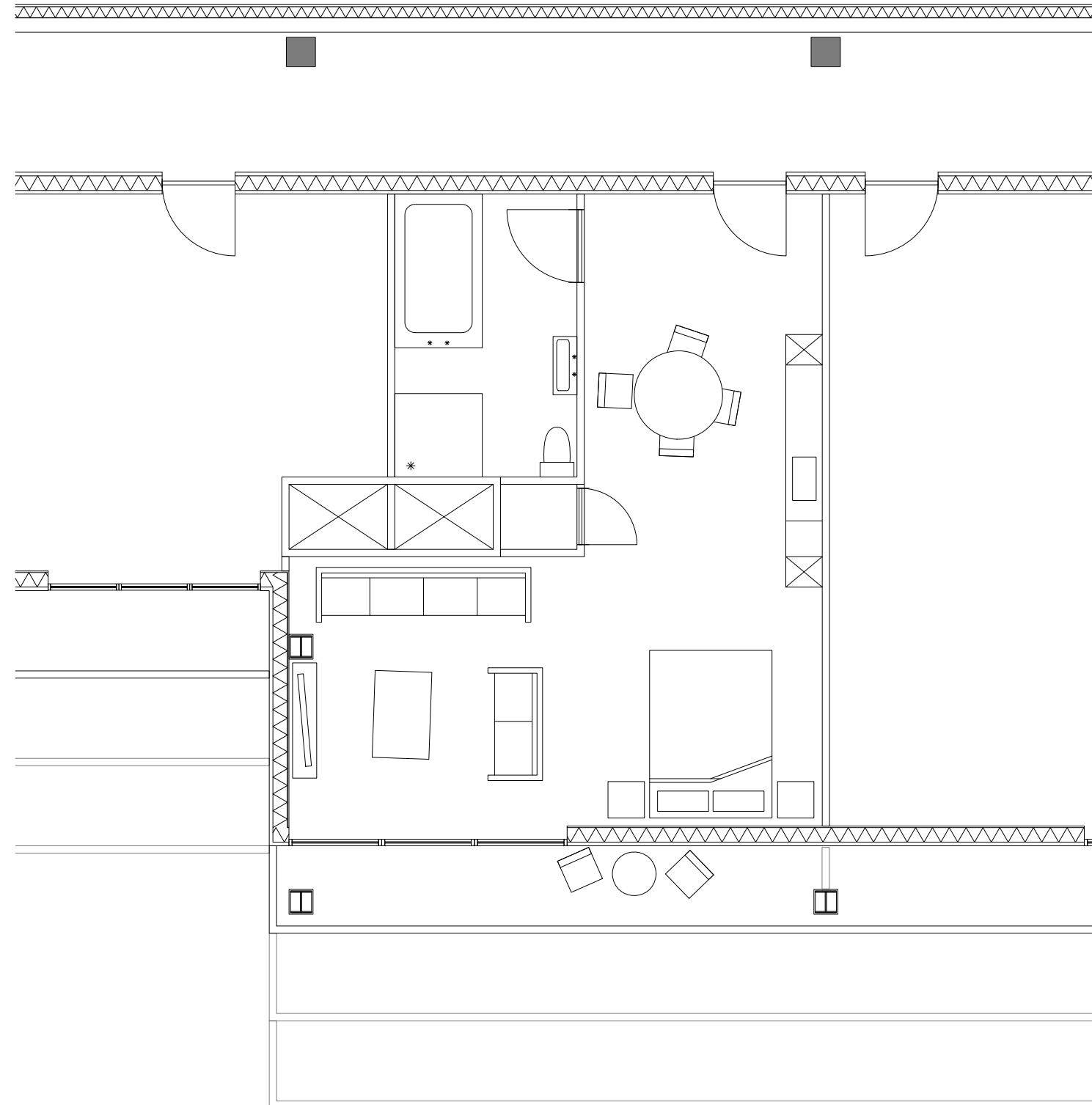

DESIGN

Urban plan

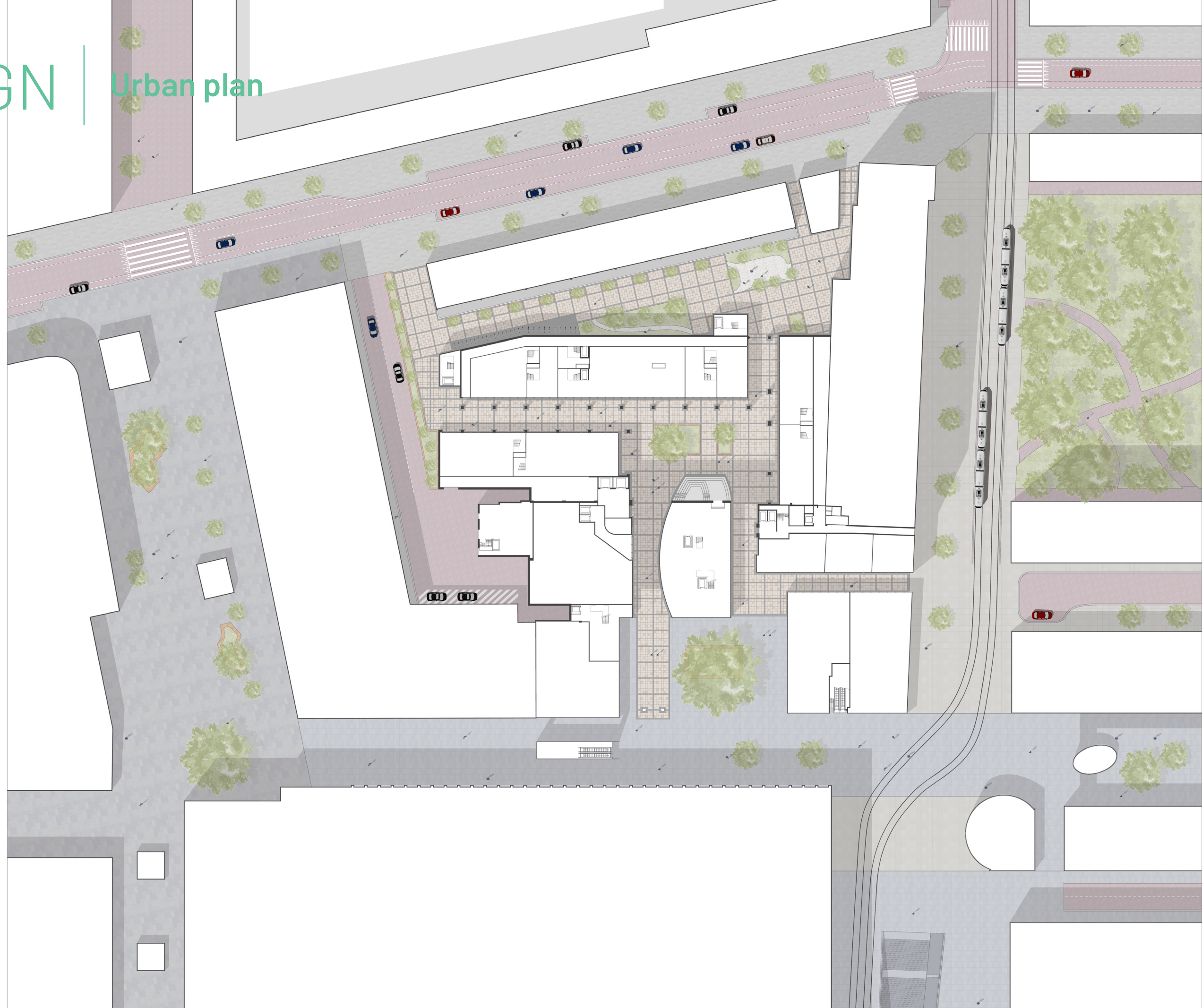

DESIGN

Network in the city

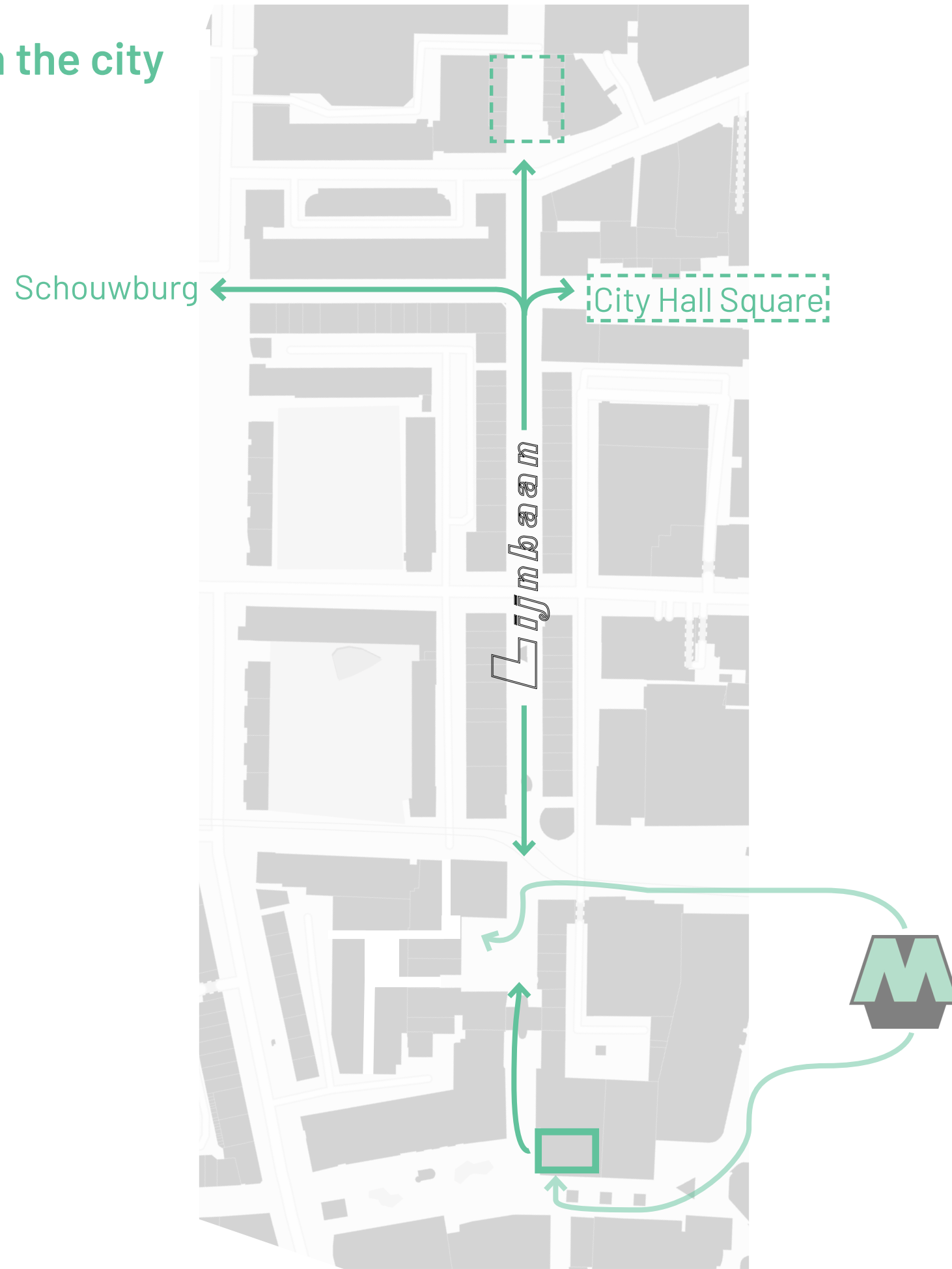

DESIGN

Urban plan

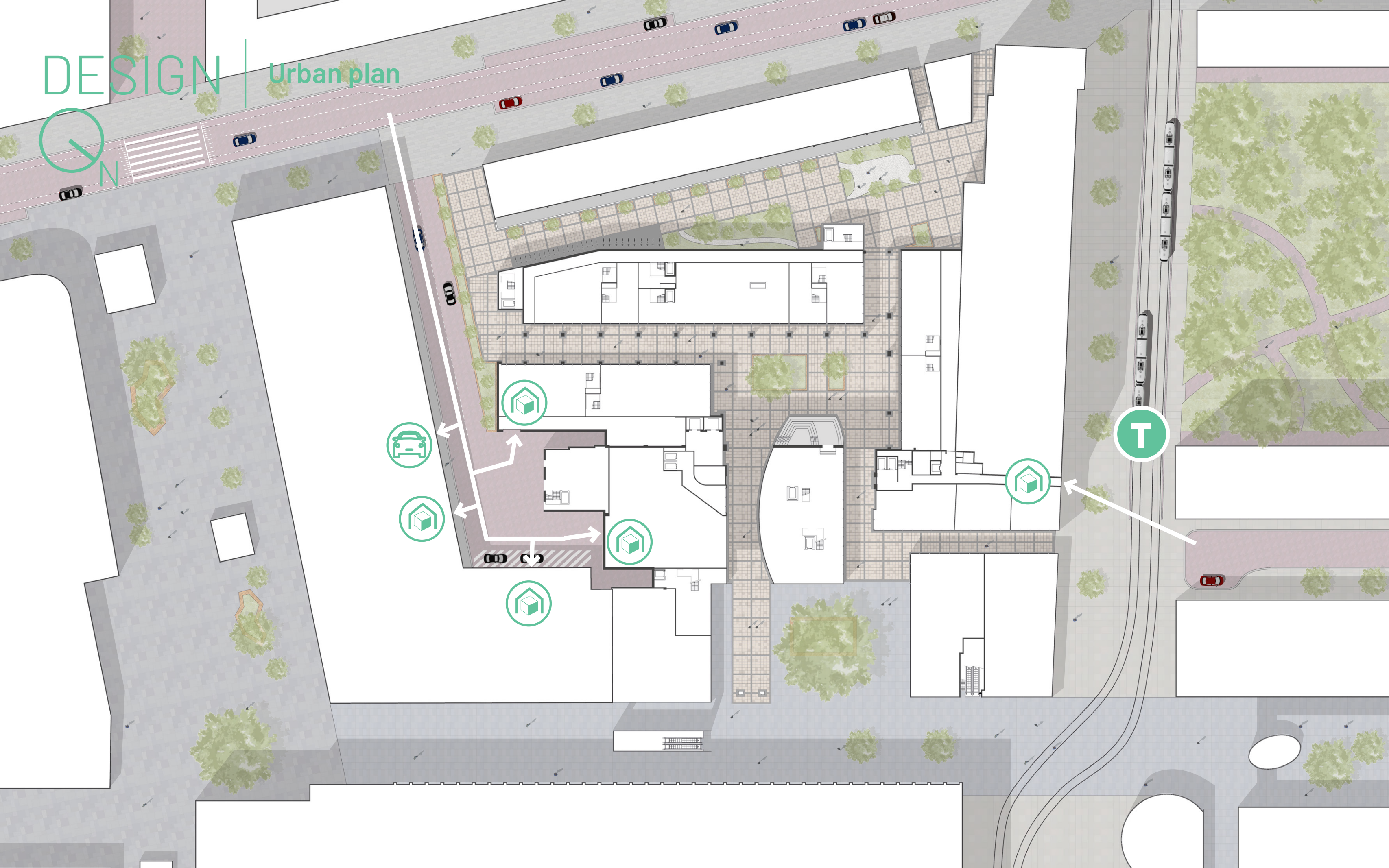
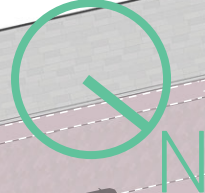

DESIGN

Urban plan

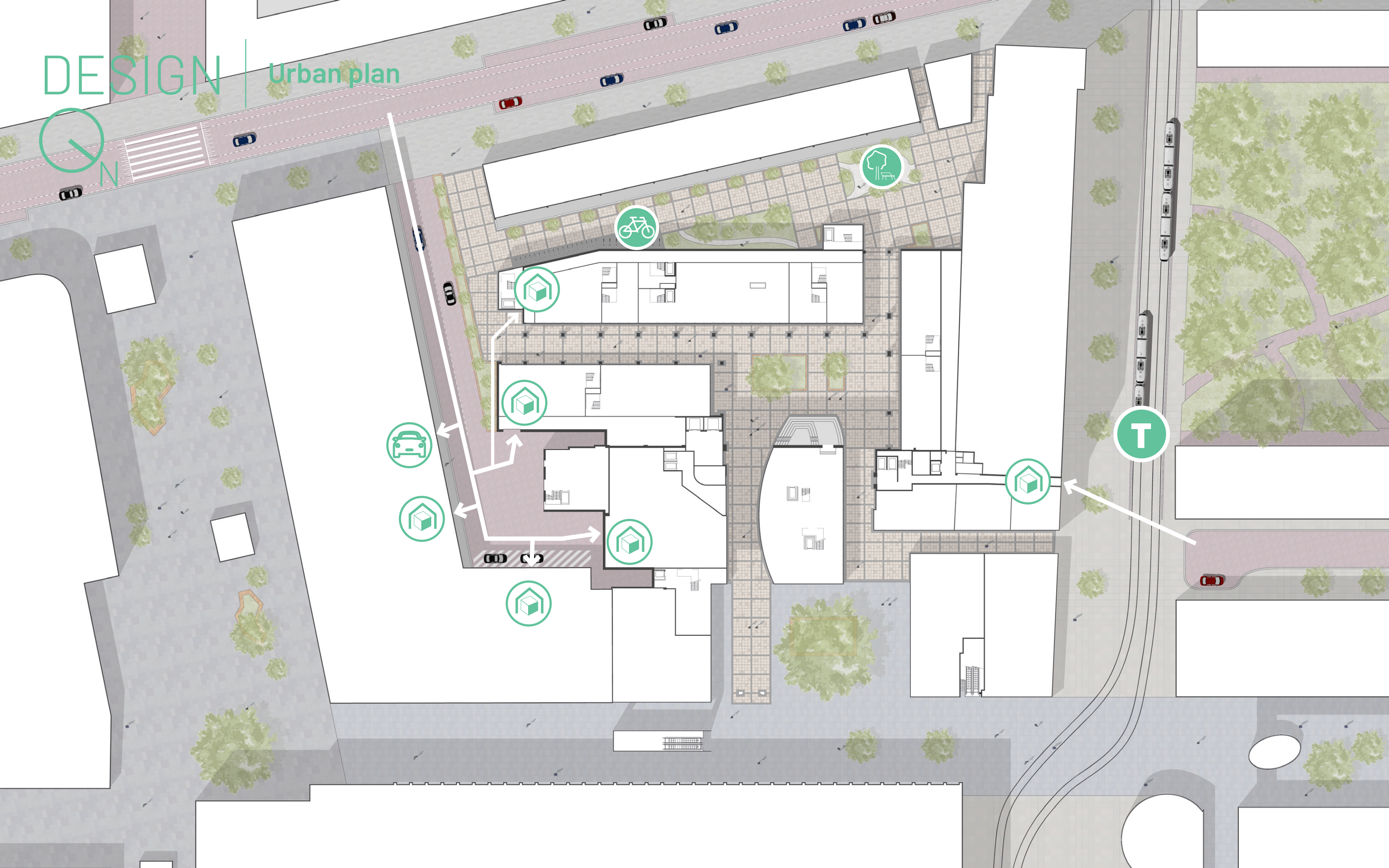
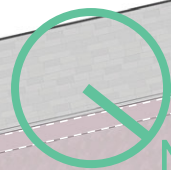

DESIGN

Logistics: Retail

Ground floor

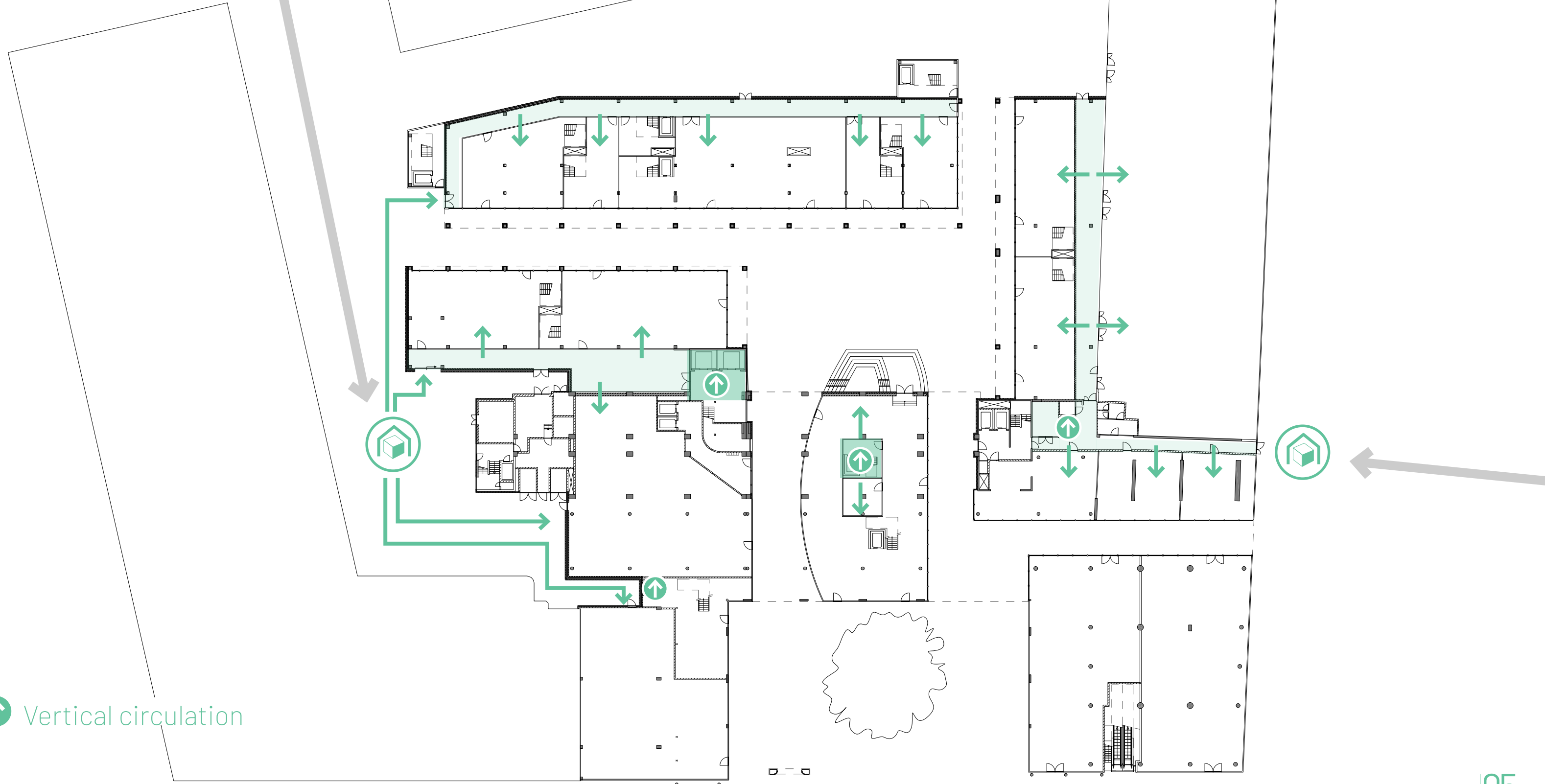

↑ Vertical circulation

DESIGN

Logistics: Retail

First floor

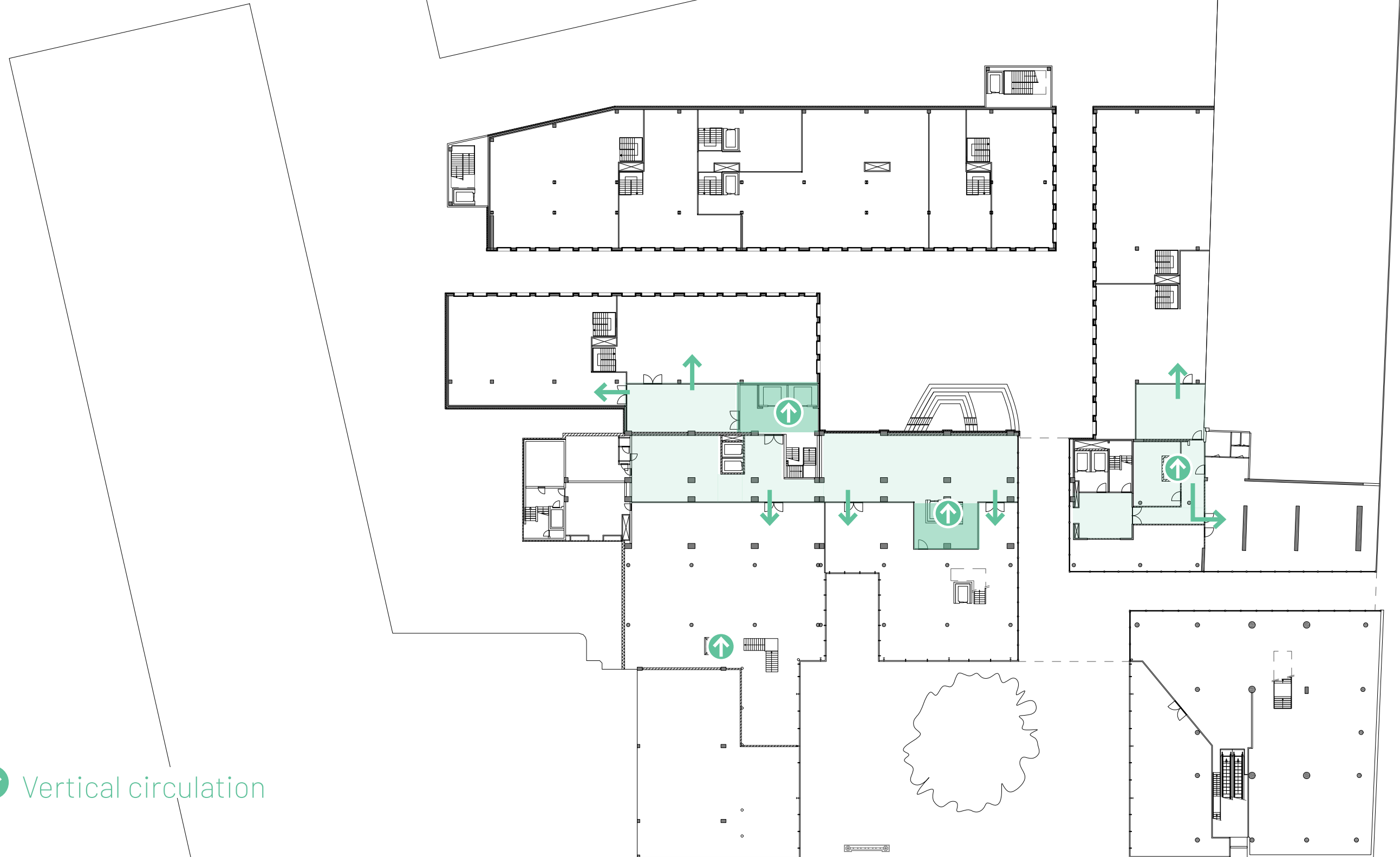

↑ Vertical circulation

DESIGN

Logistics: Retail

Second floor

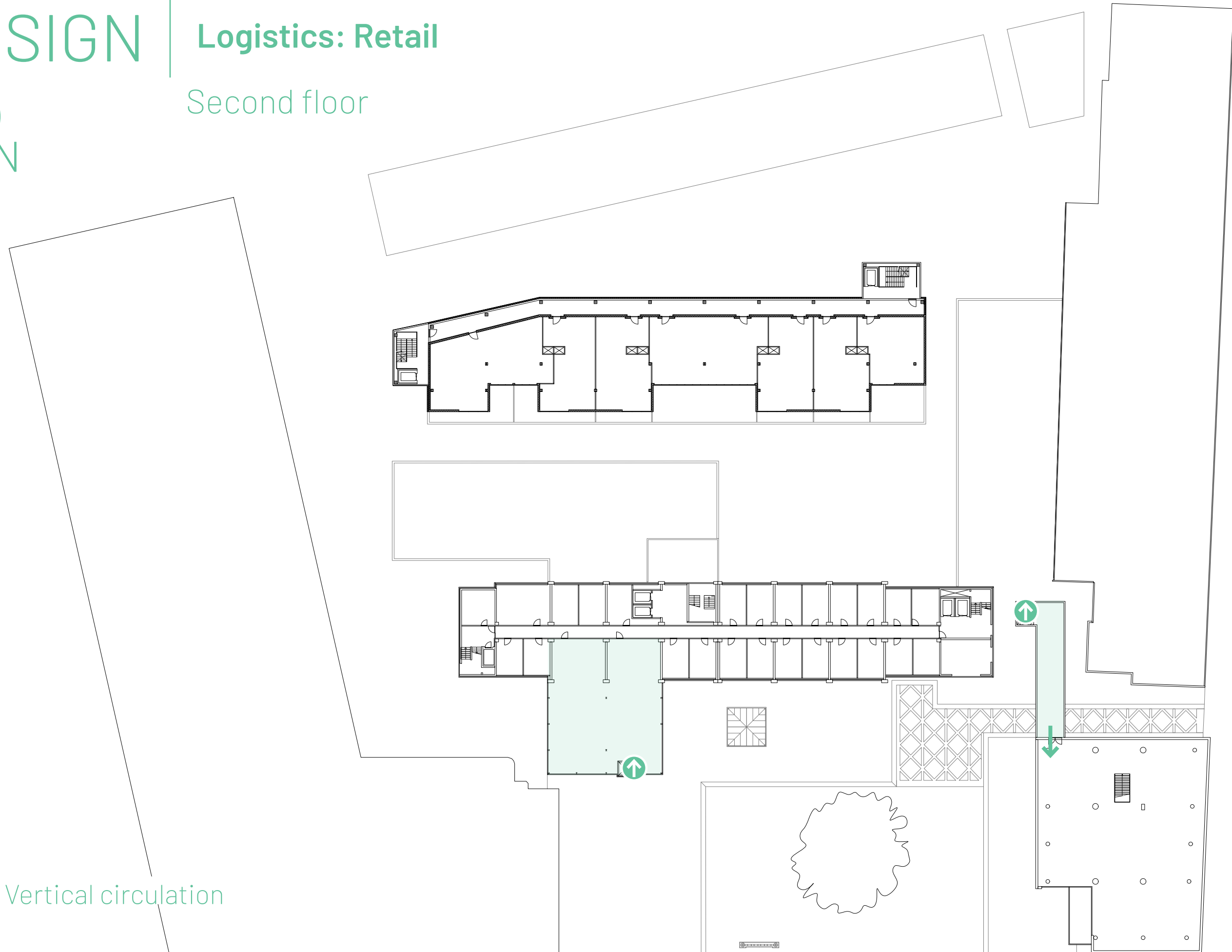

↑ Vertical circulation

DESIGN

Logistics: Housing

Ground floor

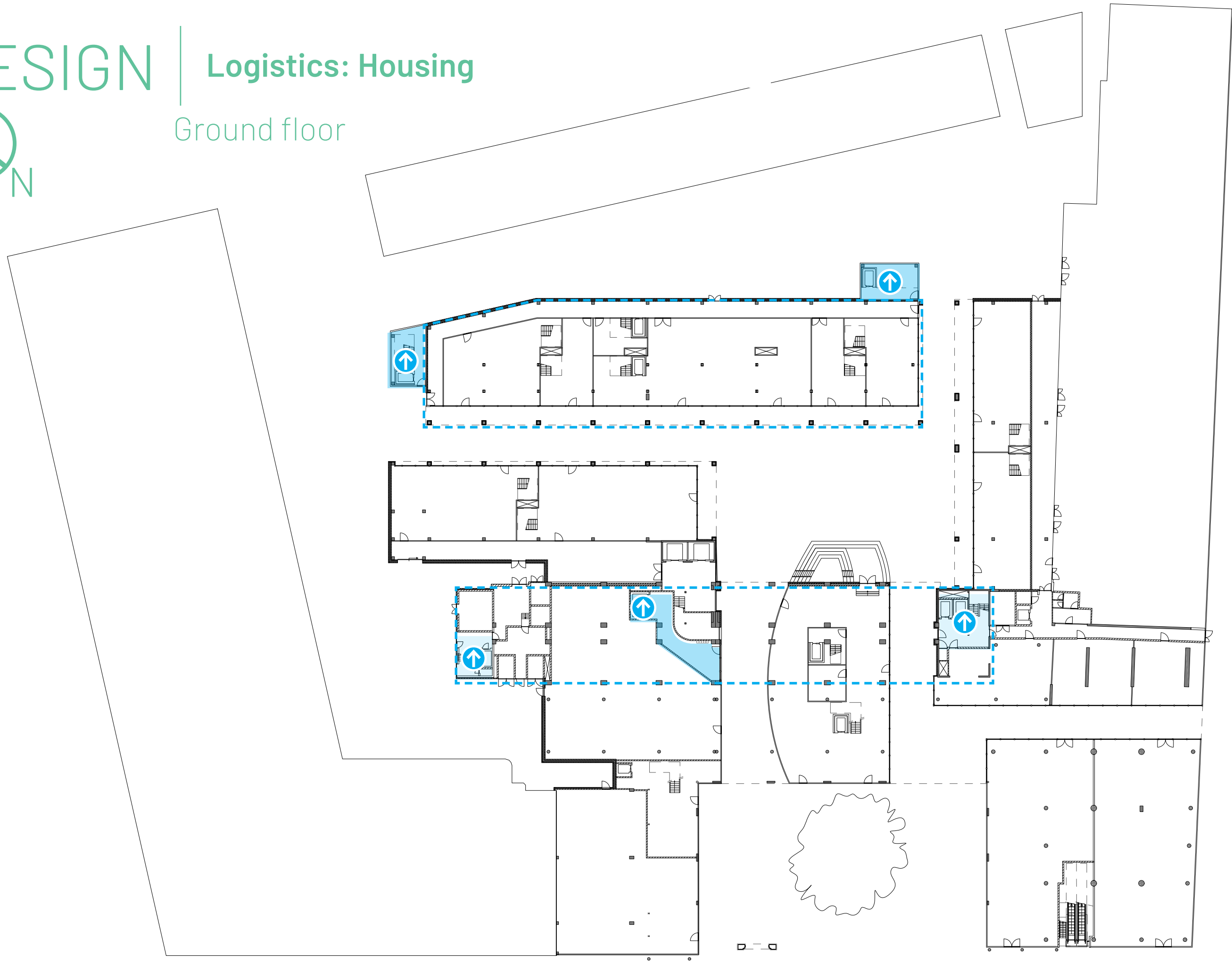

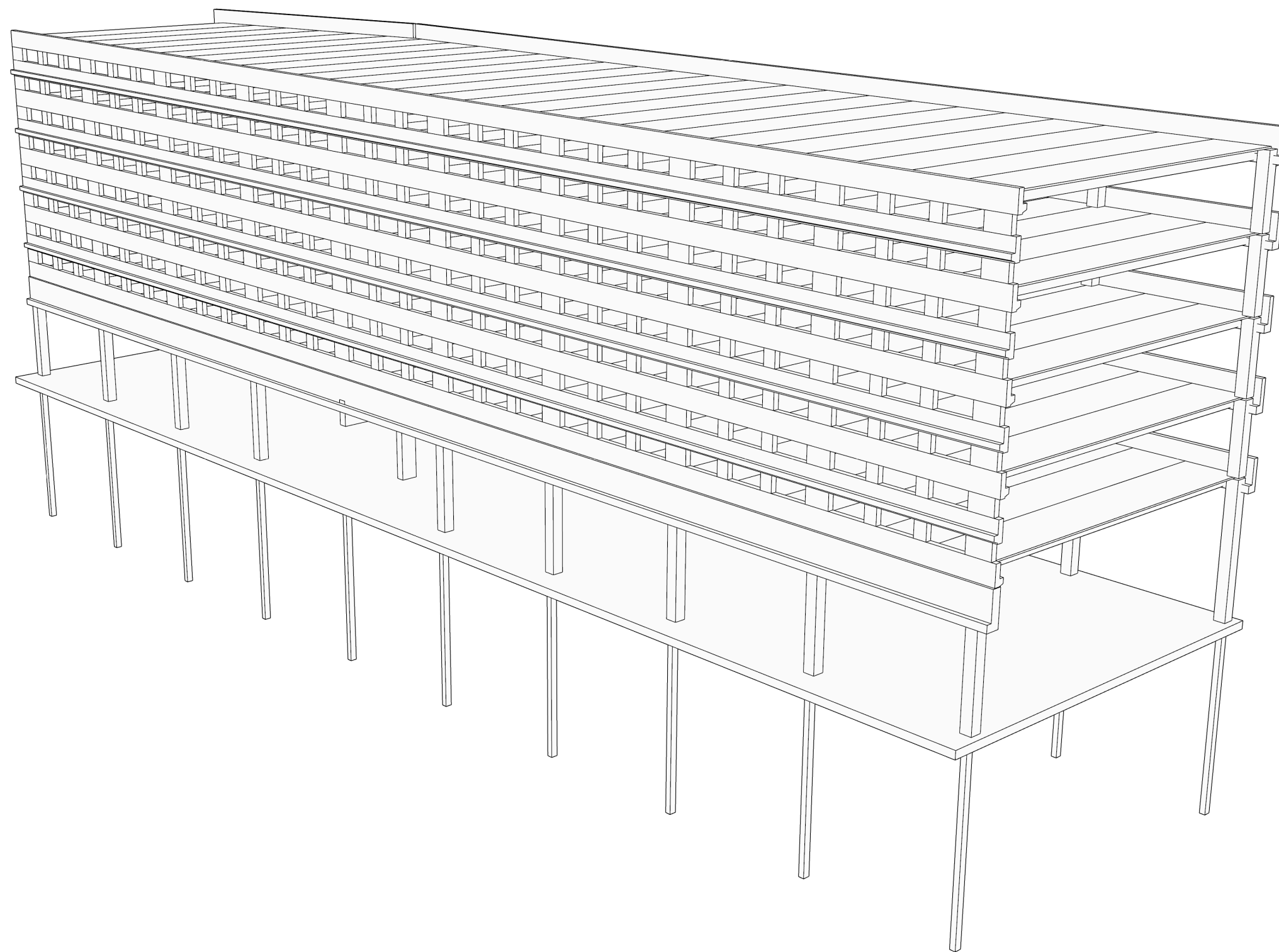
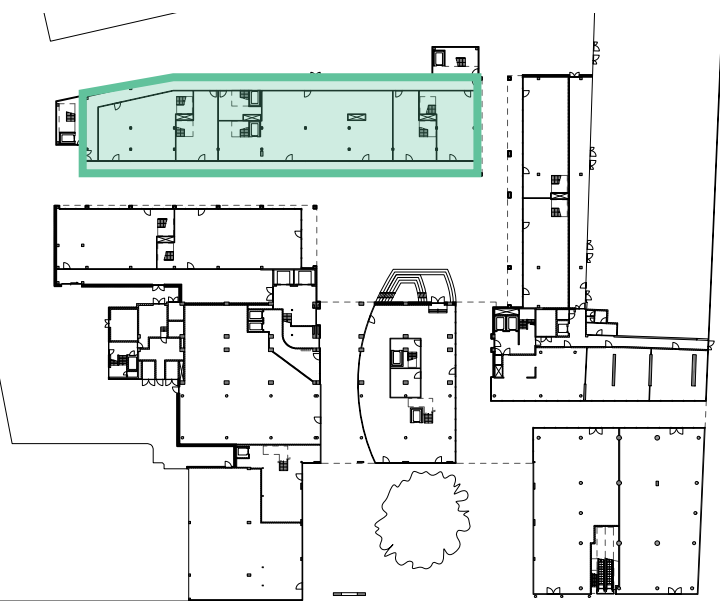

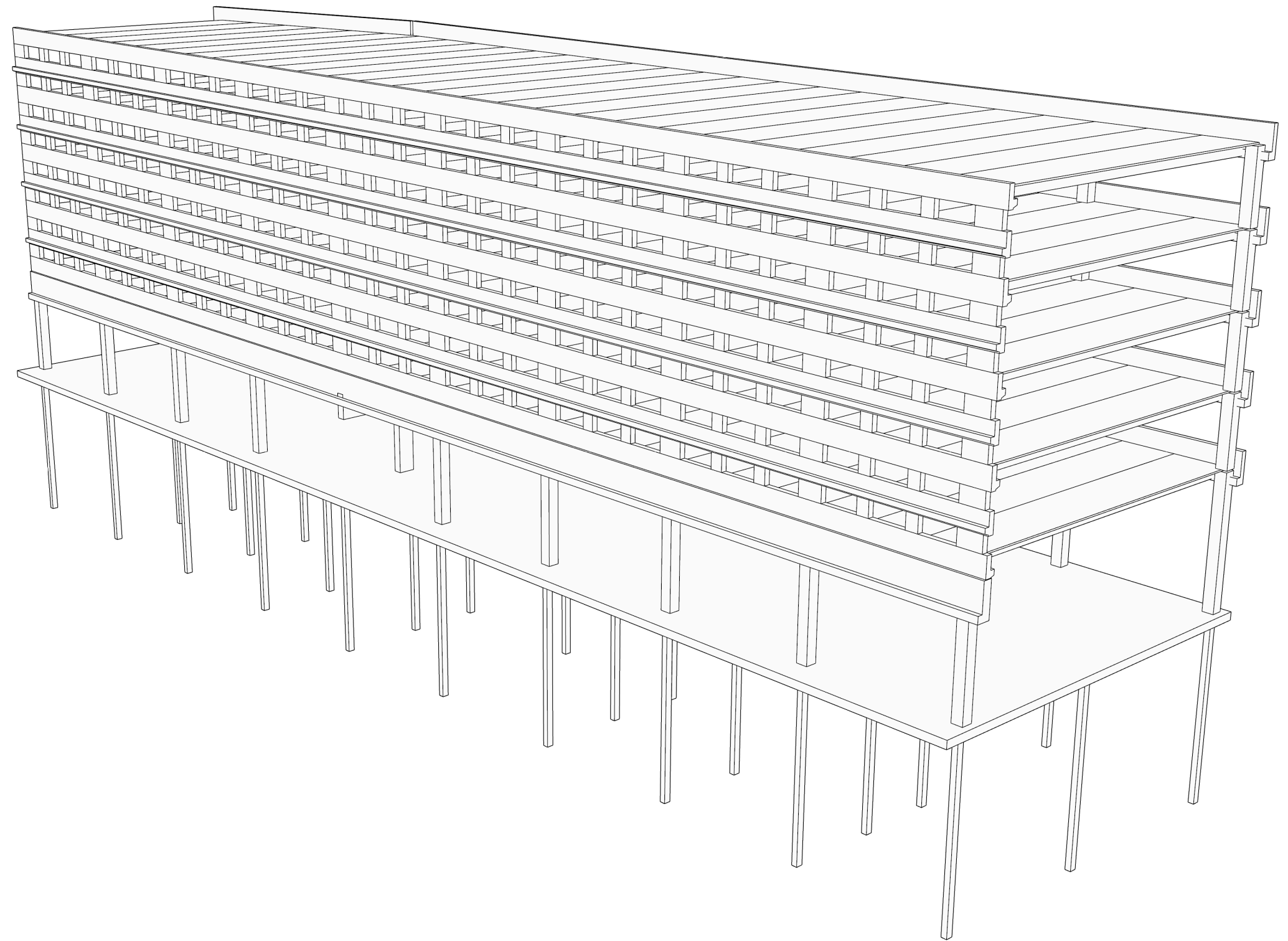

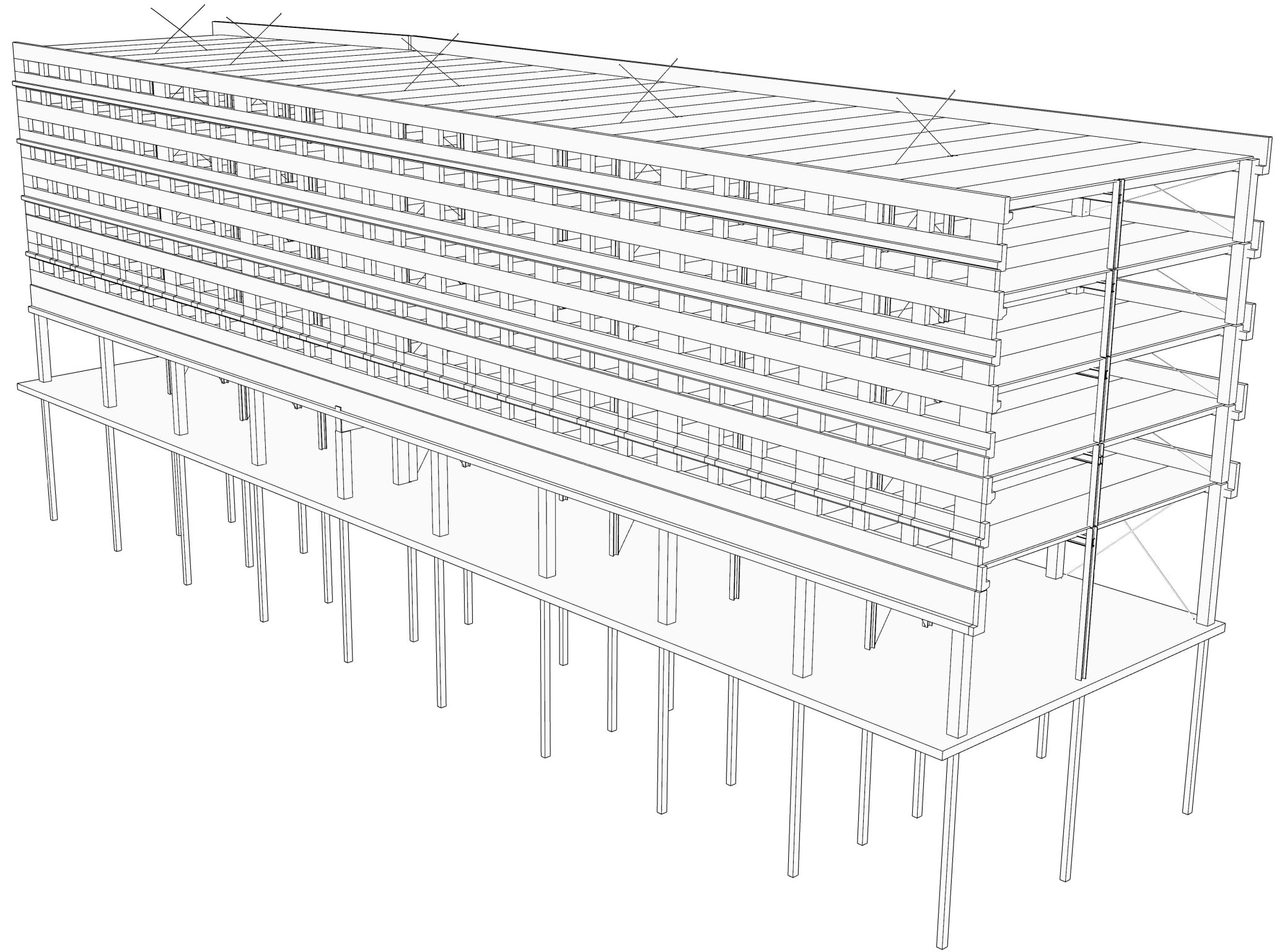

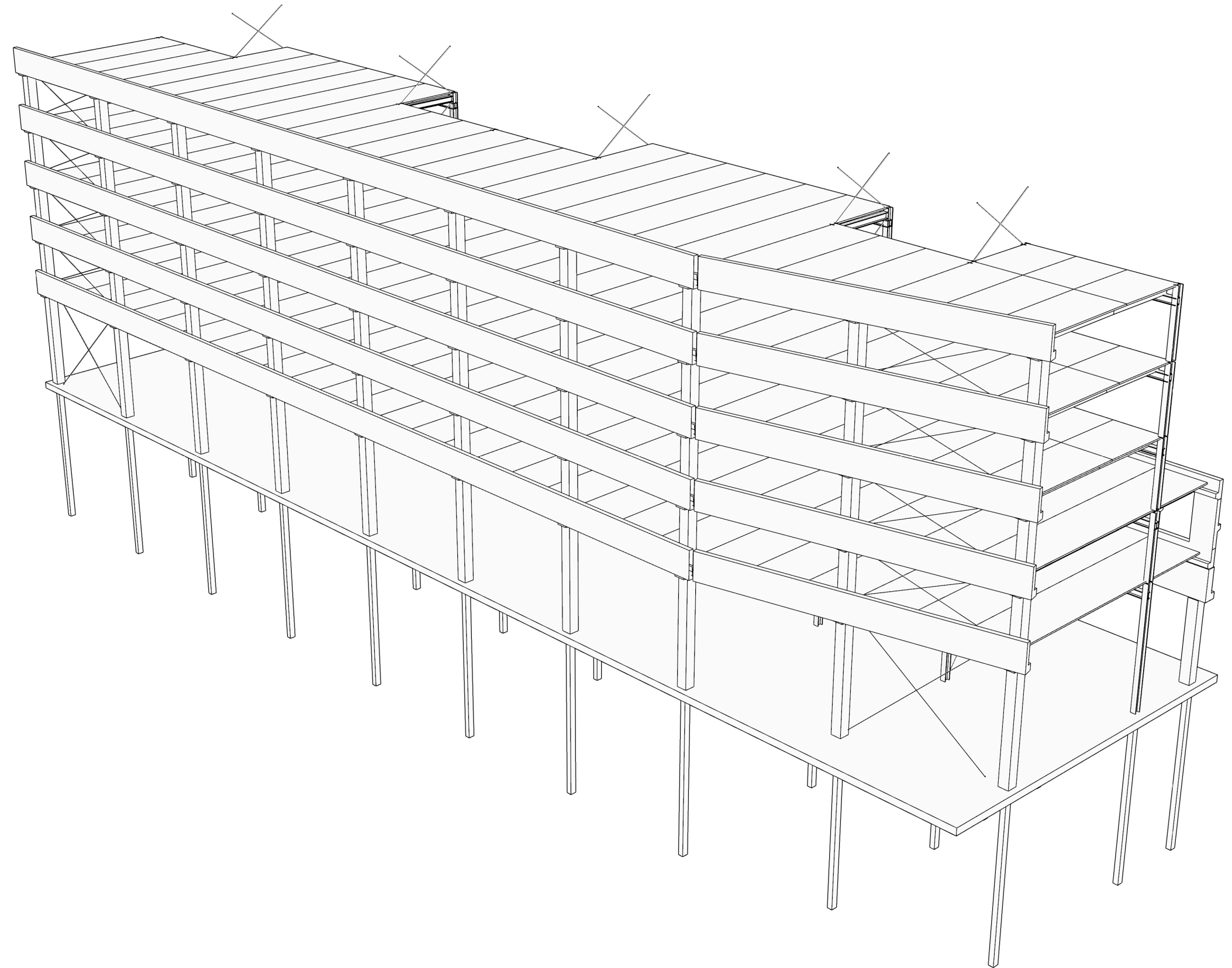

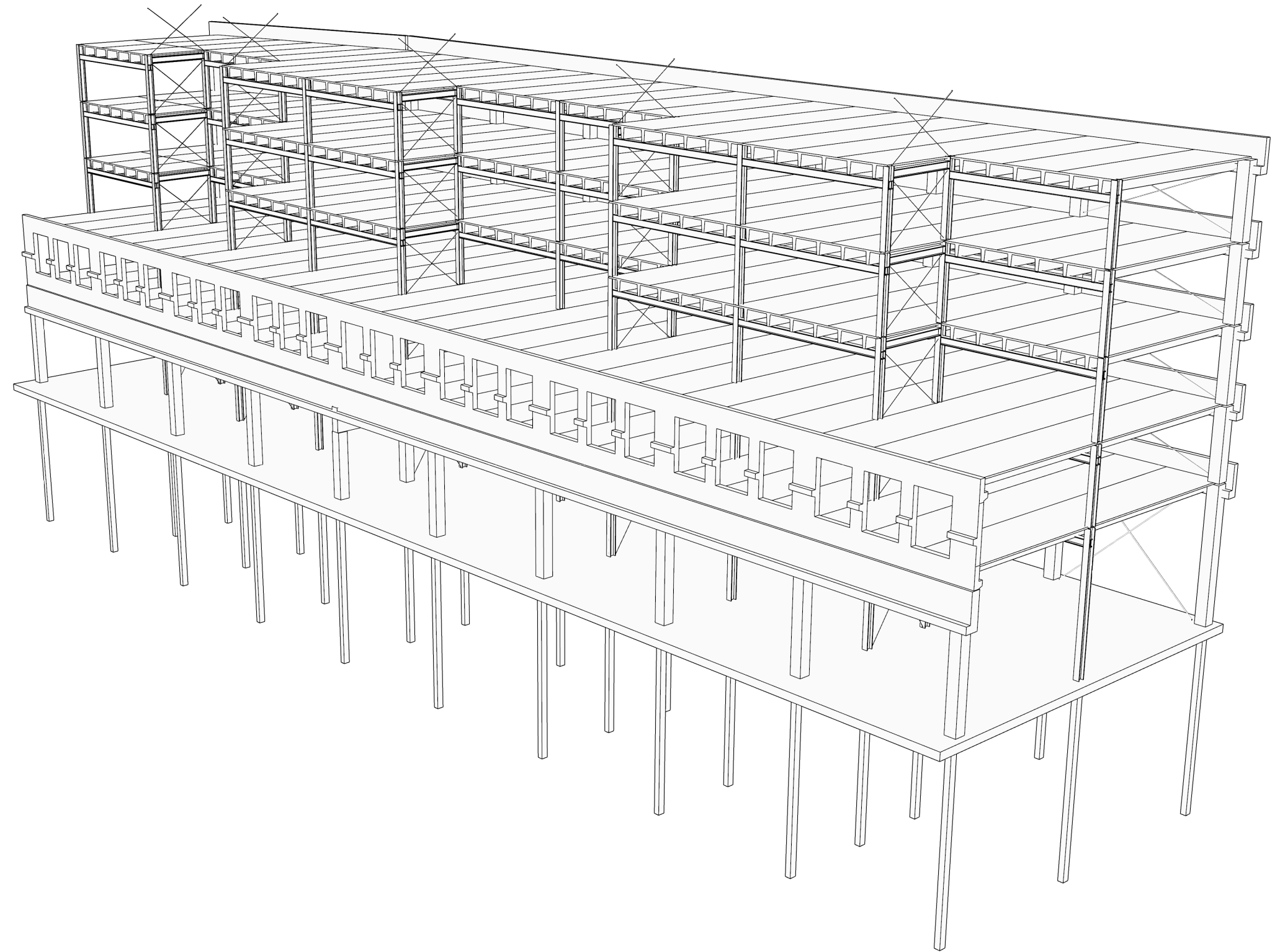

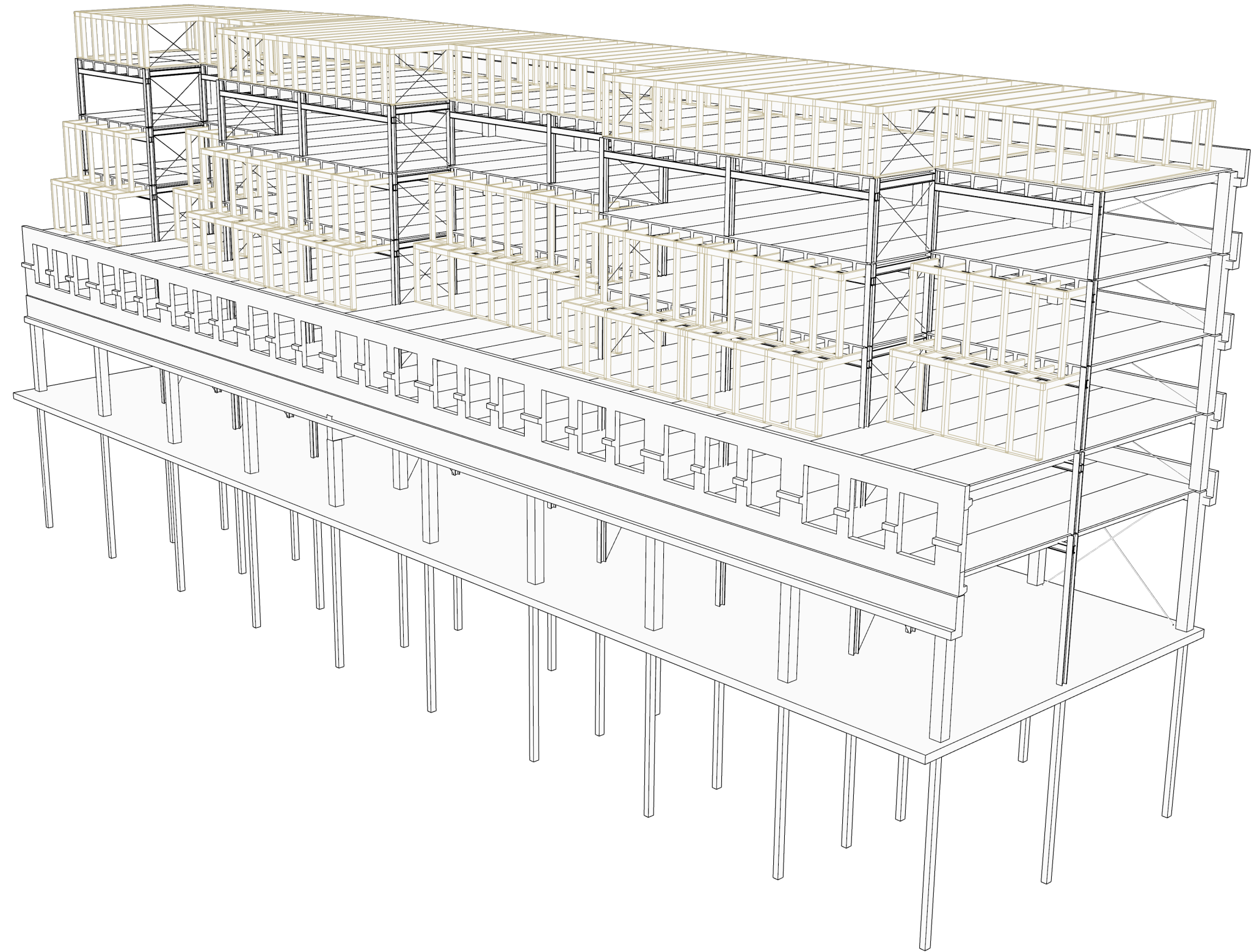

Floor: TT/620/2400

$g = 4,65 \text{ KN/m}^2$

Added load retail: 5 KN/m^2

Added load housing: $2,5 \text{ KN/m}^2$

Load of wooden roof: $2,5 \text{ KN/m}^2$

	lengte		breedte		rekenwaarde		
opp.vl dak	7	[m] x	4	[m] x	2,5	[kN/m ²]	= 70 [kN]
opp.vl dak	7	[m] x	4	[m] x	7,15	[kN/m ²]	= 200,2 [kN]
opp v4	7	[m] x	4	[m] x	7,15	[kN/m ²]	= 200,2 [kN]
opp v3	7	[m] x	4	[m] x	7,15	[kN/m ²]	= 200,2 [kN]
opp v2	7	[m] x	8	[m] x	7,15	[kN/m ²]	= 400,4 [kN]
opp v1	7	[m] x	8	[m] x	9,65	[kN/m ²]	= 540,4 [kN]
							$F_{c;d} = 1611,4 \text{ [kN]}$
$A = F_{c;d}/f_{c;d} =$	6857,02	[mm ²]	-->	HEA 400			
$f_{c;d} =$	235	[N/mm ²]					
$l_{cr} =$	4,5	[m]		$E =$	210000	[N/mm ²]	$I_z = 8,564E+07 \text{ [mm}^4\text{]}$
$F_{cr} =$	8,77E+06	[N]					
$UC =$	0,92			$I_{z \text{ ben}} =$	7,87E+07	[mm ⁴]	--> HEA 400

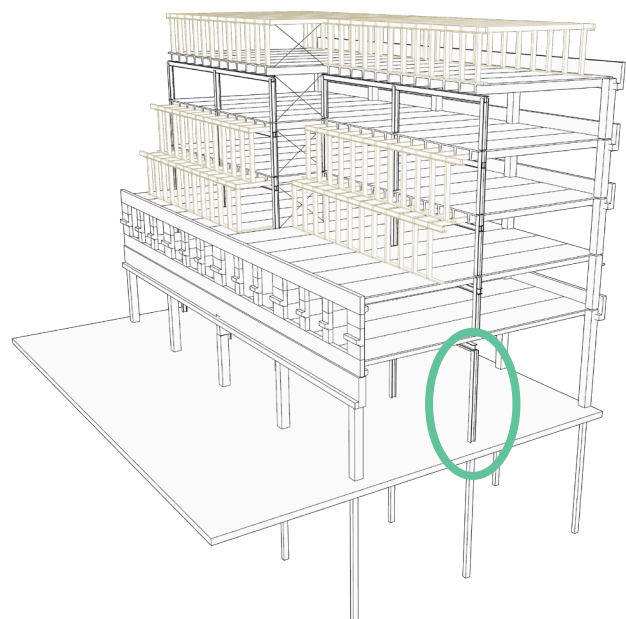

HEA 400 on ground floor



DESIGN

Construction

Floor: TT/620/2400

$g = 4,65 \text{ KN/m}^2$

Added load housing: $2,5 \text{ KN/m}^2$

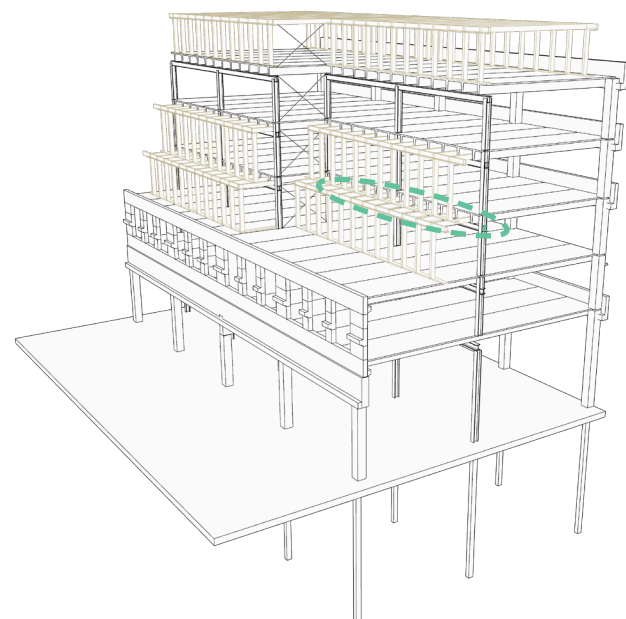

HEM 260	$\ell_{\text{hoh}} =$	11,9	[m]				
	$q_{\text{tot rekenw}} =$	10	[kN/m ²]		$W =$	2159000	[mm ³]
	$q_{\text{UGT}} =$	119	[kN/m]		$I =$	313700000	[mm ⁴]
	$q_{\text{Q;kar.w}} =$	2,5	[kN/m ²]				
	$q_{\text{BGT}} =$	29,75	[kN/m]		$f_{cd} =$	355	[N/mm ²]
	$\ell_{\text{oversp}} =$	7	[m]		$E =$	210000	[N/mm ²]
sterkte							
	veld mom =	728875000	[Nmm]		$\sigma_m =$	337,5984252	[N/mm ²]
	UC =	0,95			$W_{\text{benodigd}} =$	2053169,014	[mm ³]
stijfheid							
	$U_{\text{bij}} =$	14,12	[mm]		$U_{\text{bij norm vloer}} =$	21,0	[mm]
					$U_{\text{bij norm vl.wand}} =$	14,0	[mm]
	UC vloer =	0,67			$I_{\text{benodigd}} =$	210901331	[mm ⁴]
	(UC vl.wand =	1,01			$I_{\text{benodigd}} =$	316351996,5	[mm ⁴]

HEM 260 Beam



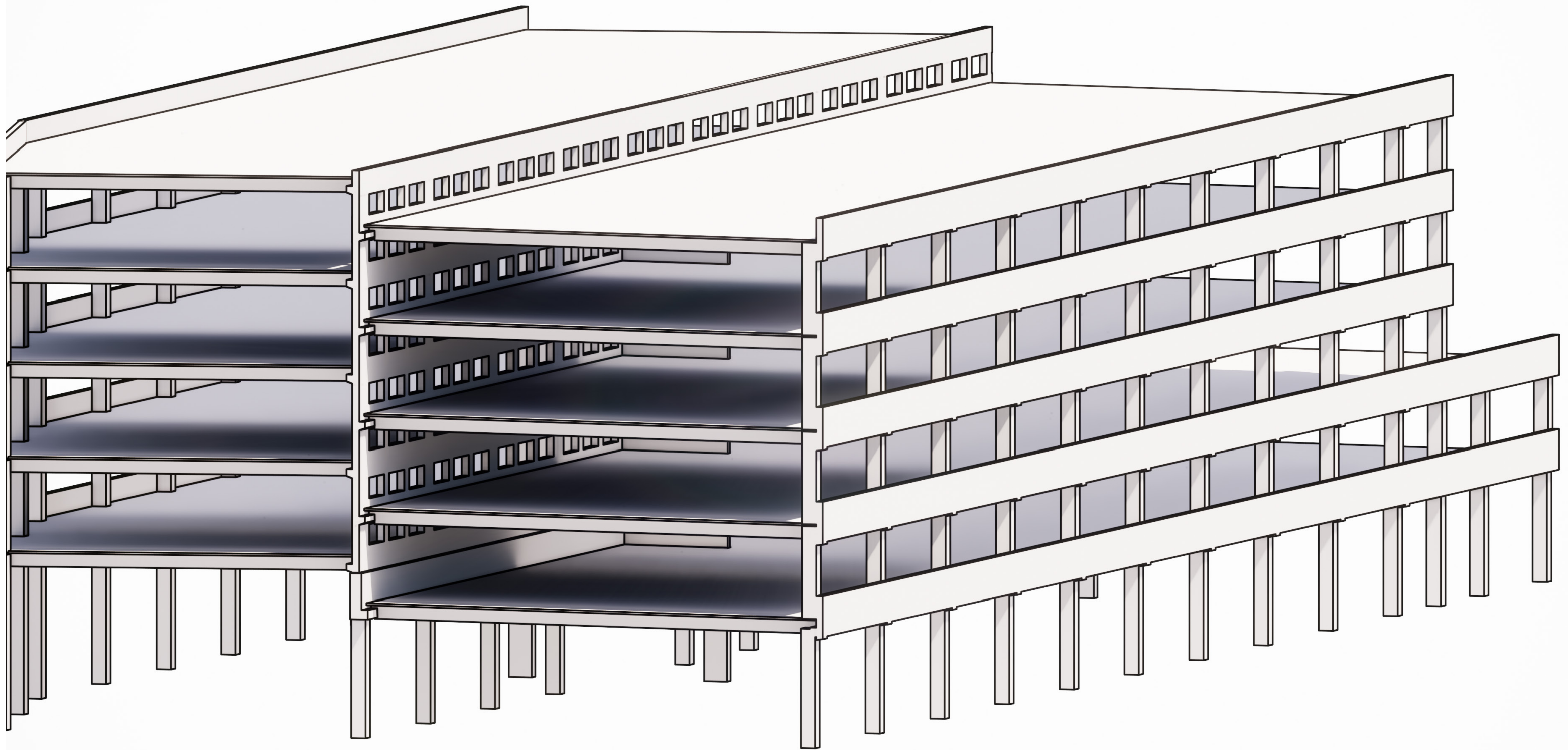

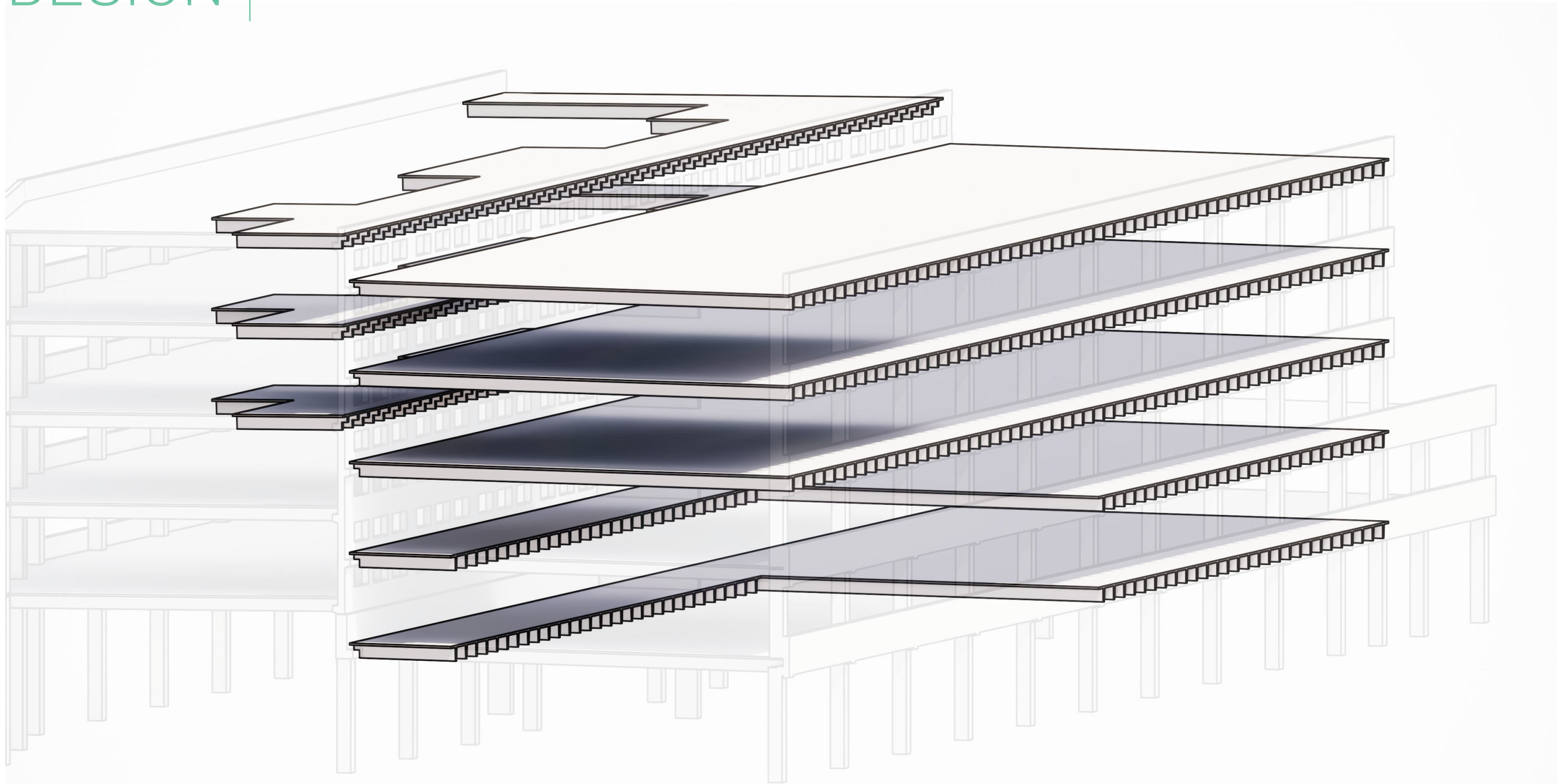

Remove: Concrete Floors
758 m³

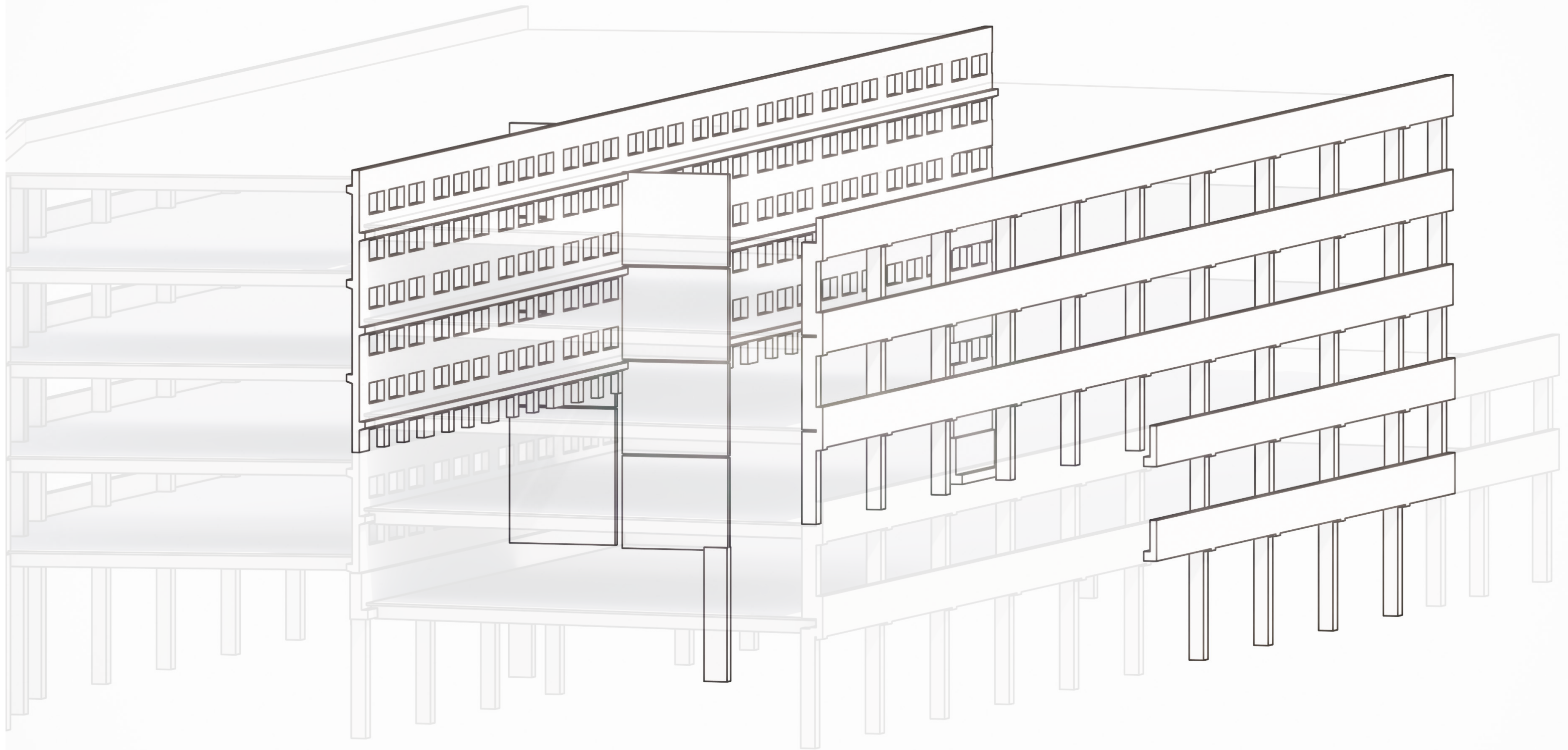

Remove: Concrete construction
305 m³ (Total 1063m³)

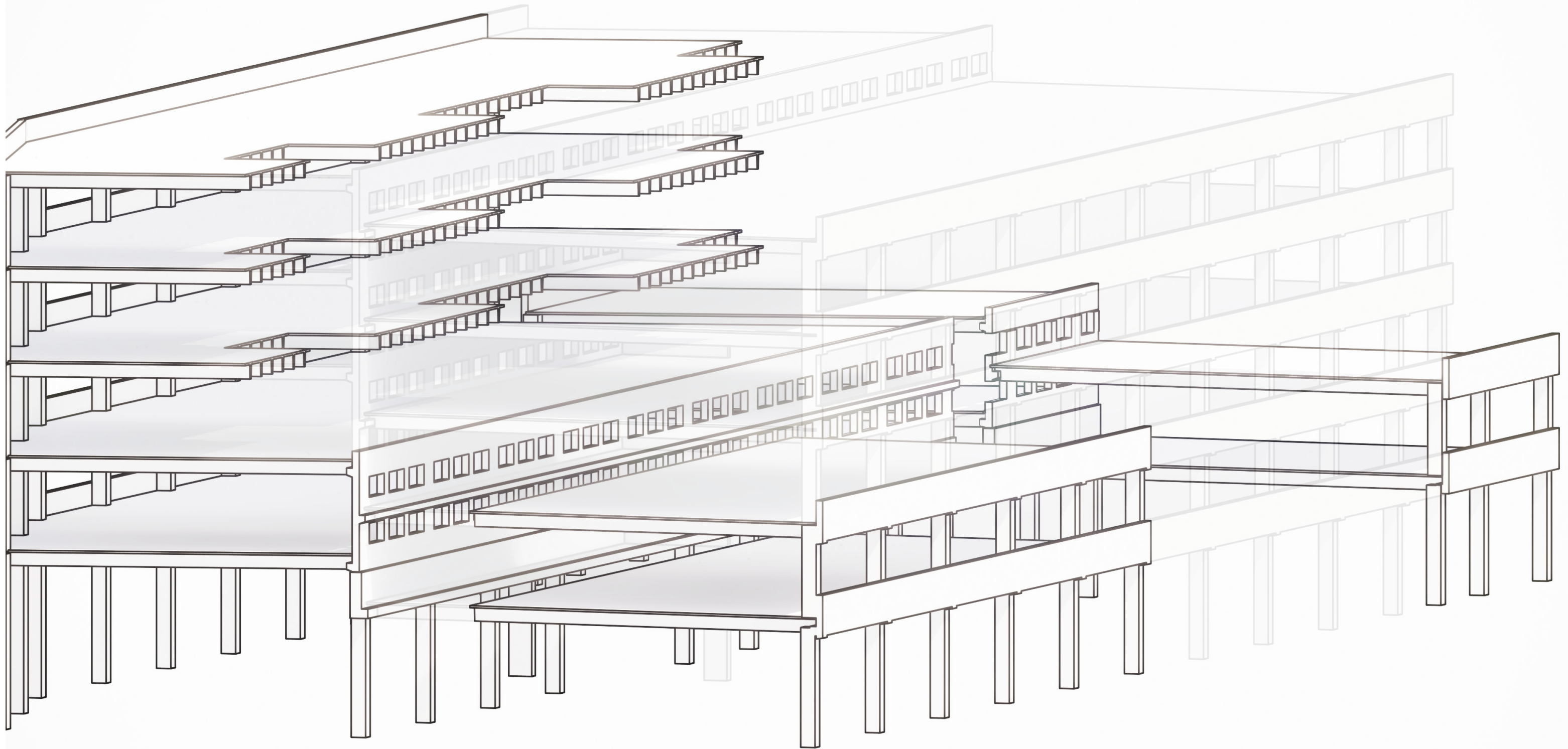

Keep : Construction & Floors
1134 m³

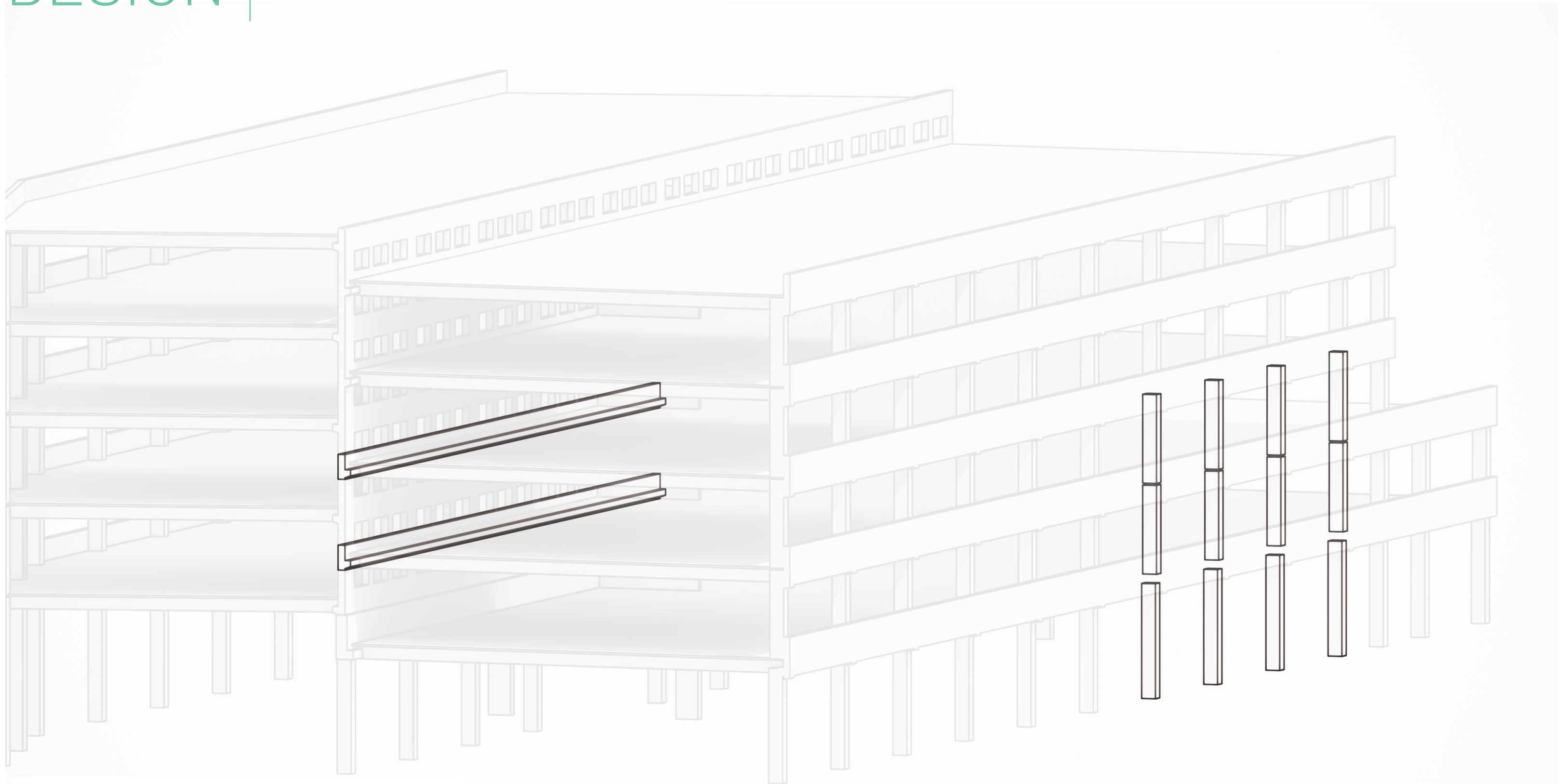

Reuse: Construction
30 m³

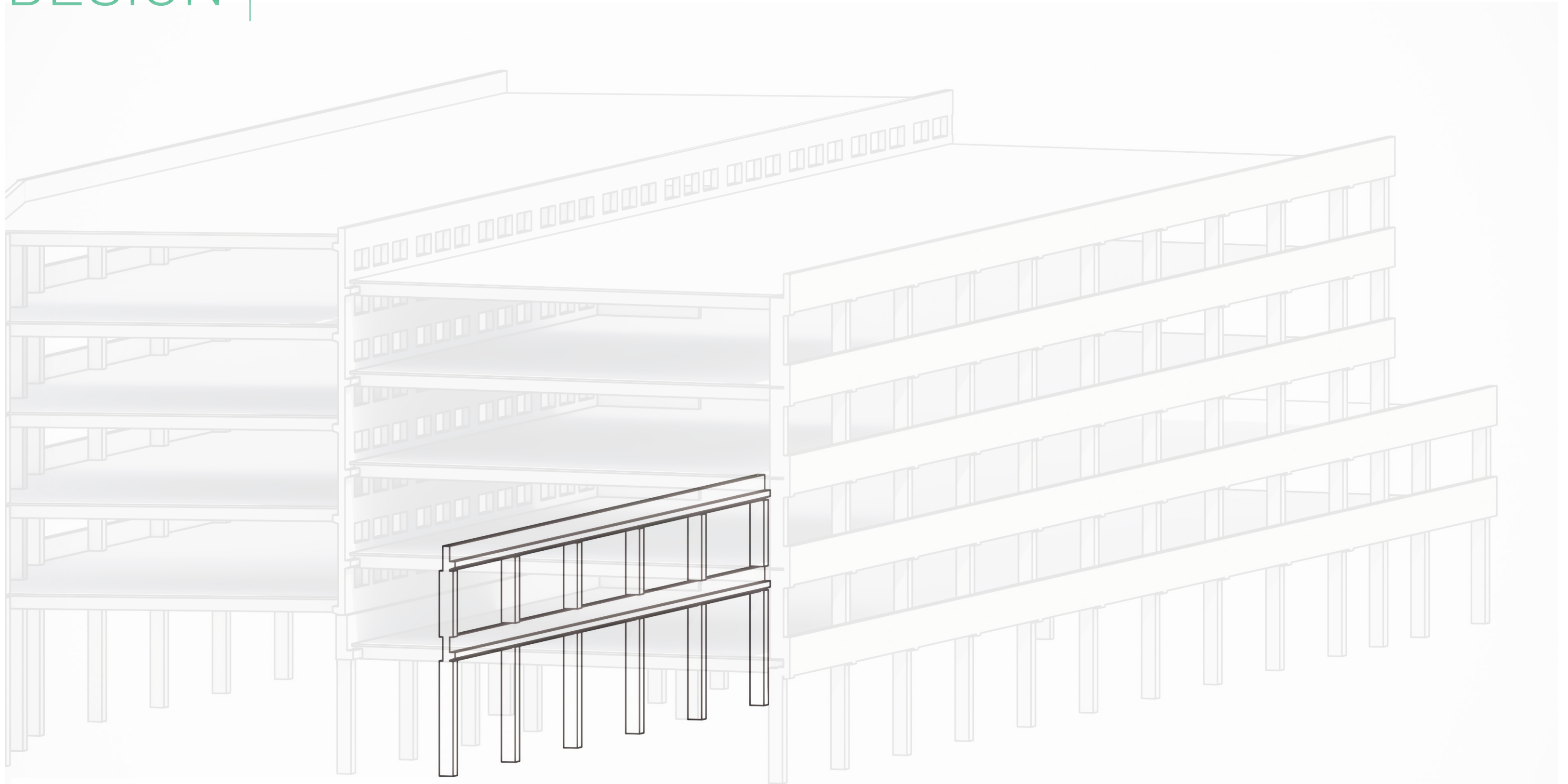

Reuse: Construction
30 m³

DESIGN



Material removal

Ground floor

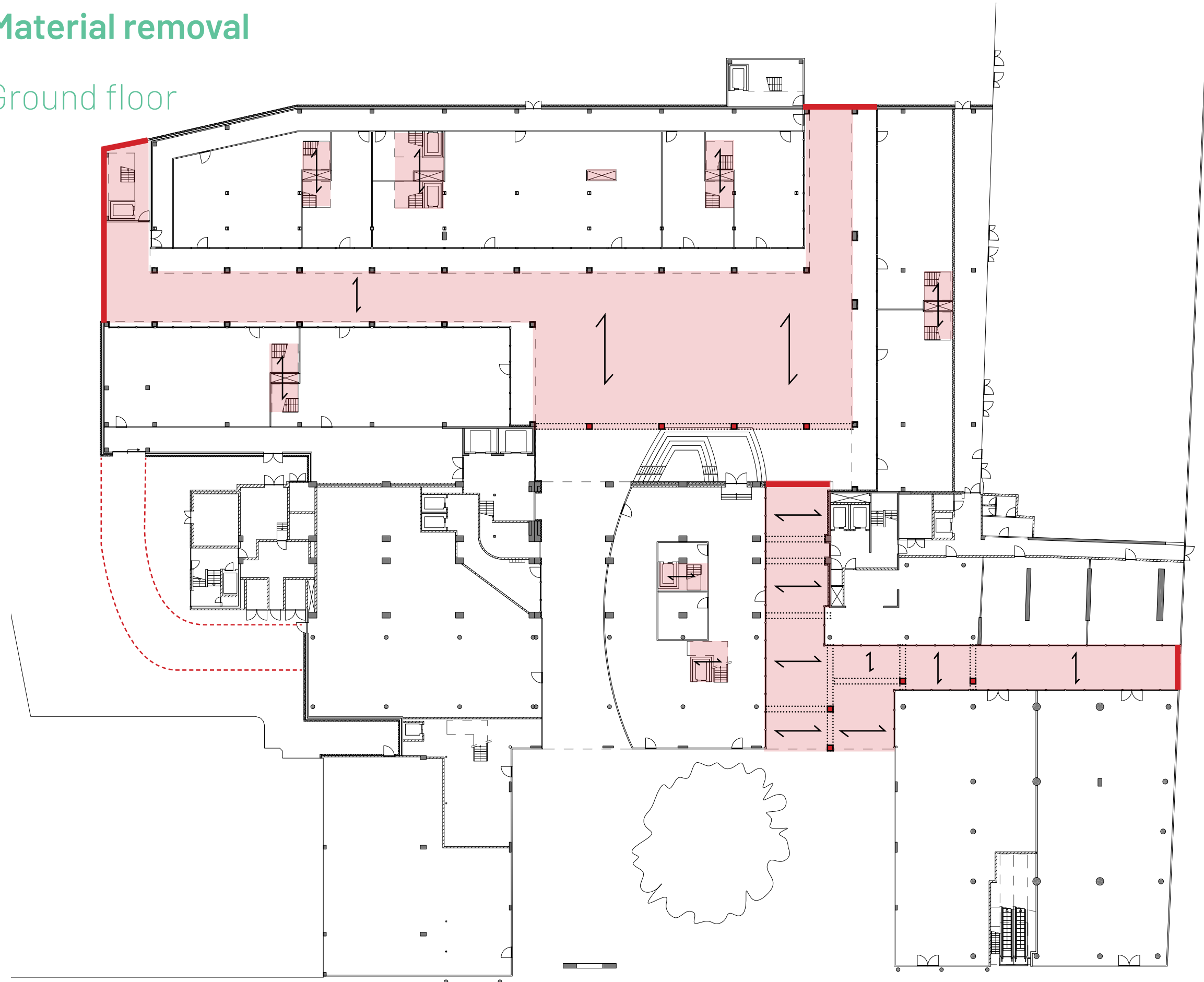

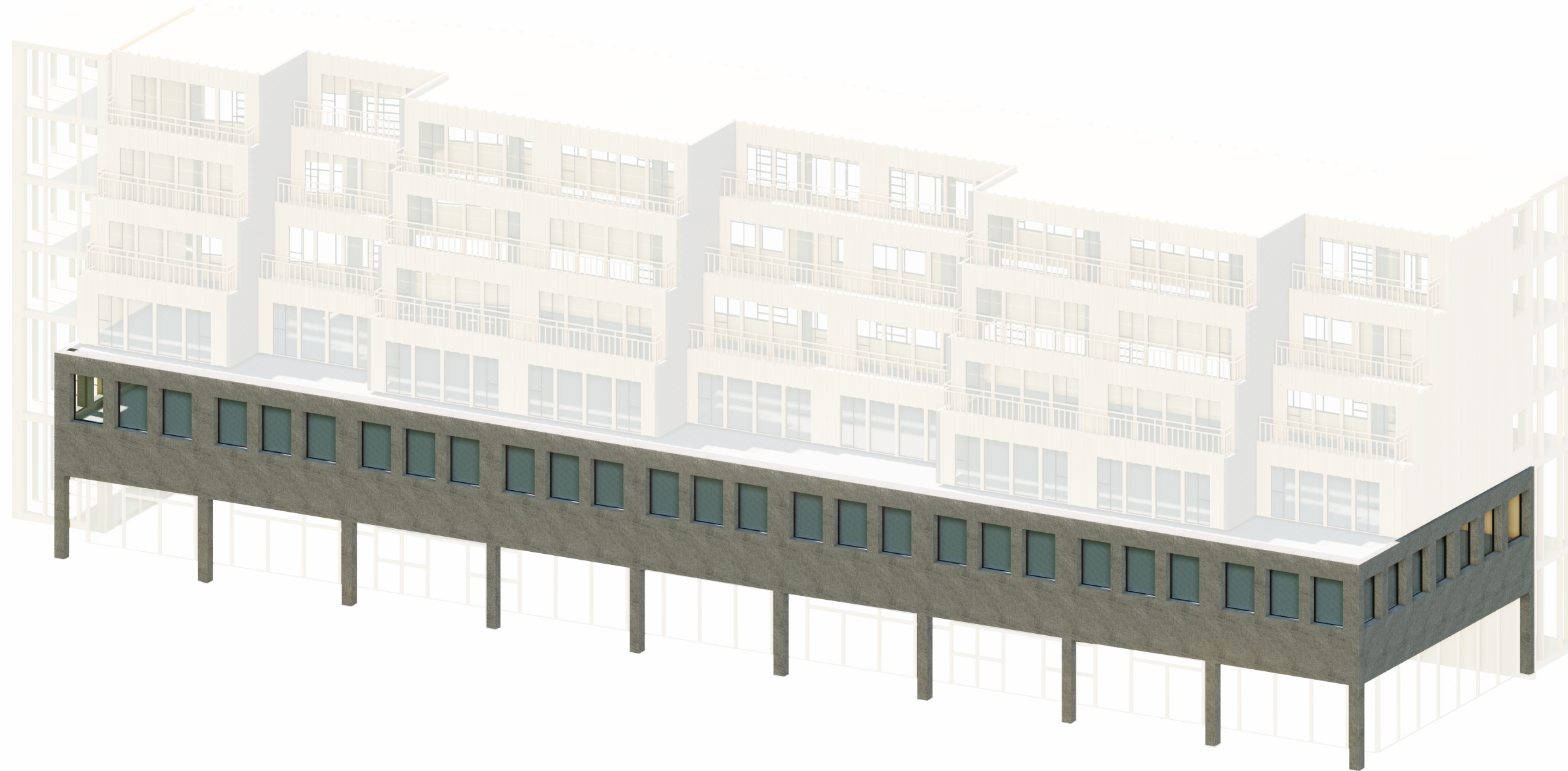

Reuse: Façades

$\sim 950\text{m}^2 * 0.01 = 10 \text{ m}^3$

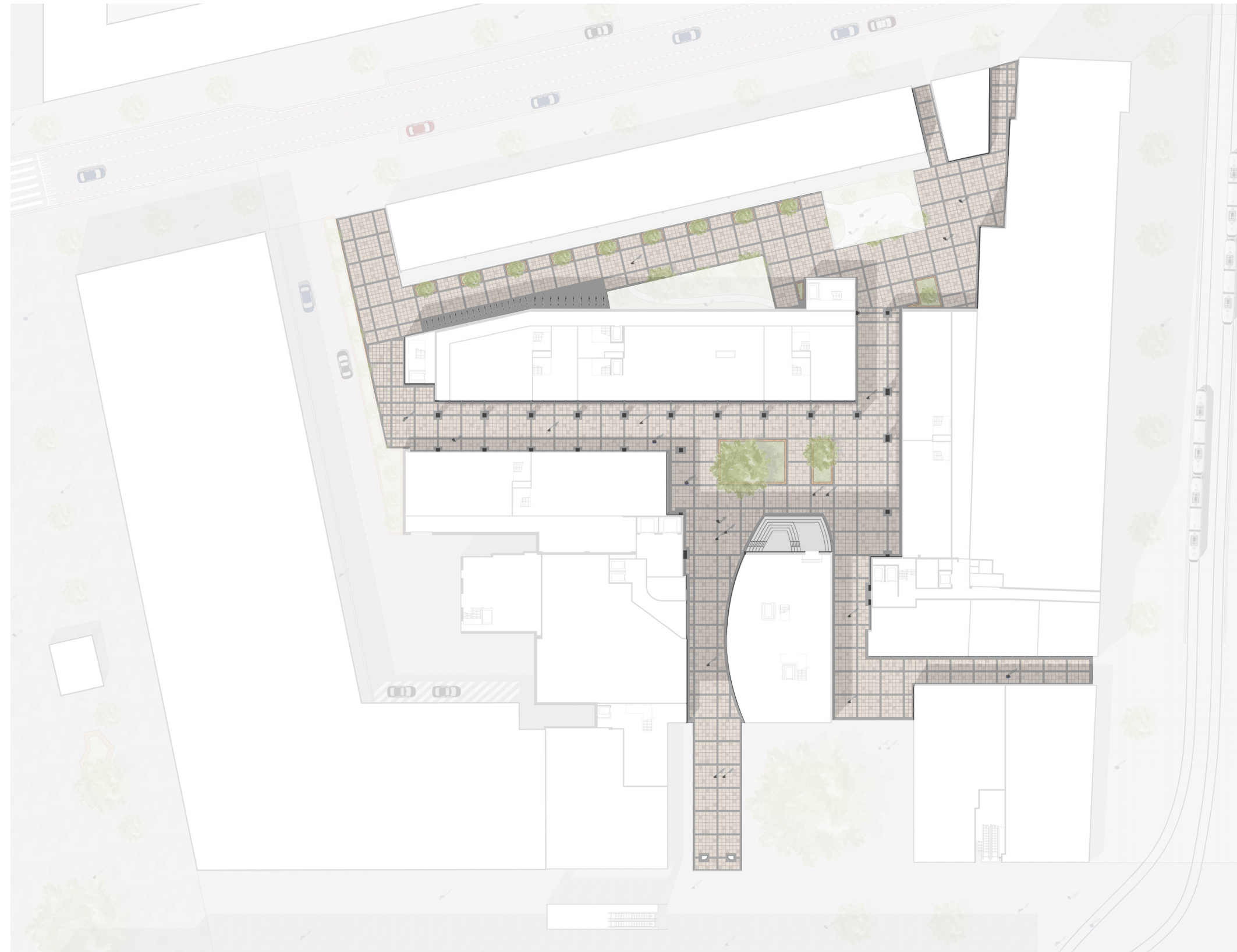

Reuse: Street tiling
 $\sim 4000\text{m}^2 * 0,01 = 40\text{m}^3$





DESIGN

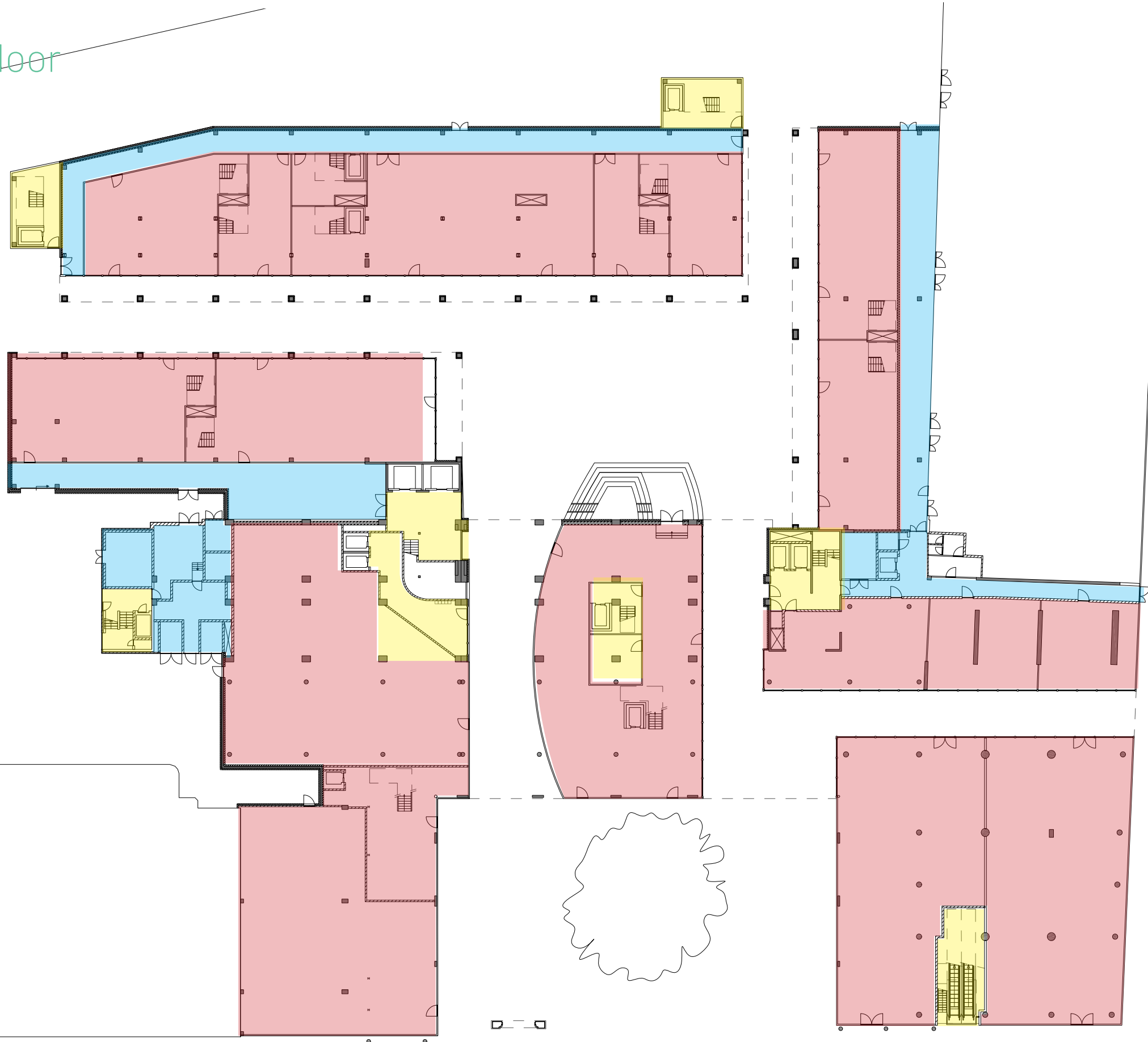

Temperature demands

Ground floor



-  Shopping area: constant heating/cooling
-  Storage/logistics: no heating
-  Circulation spaces: no heating (residual heat)
-  Space for personnel/storage: Less heating





DESIGN



Temperature demands

First floor







-  Shopping area: constant heating/cooling
-  Storage/logistics: no heating
-  Circulation spaces: no heating (residual heat)
-  Space for personnel/storage: Less heating

DESIGN

Temperature demands



-  Shopping area / housing: constant heating/cooling
-  Storage/logistics: no heating
-  Circulation spaces: no heating (residual heat?)
-  Space for personnel/storage: Less heating



Climate zones

I New HSB façade elements attached to parking garage construction
LTV floor heating in new screed
Mechanical ventilation D
Separate heating network for each volume

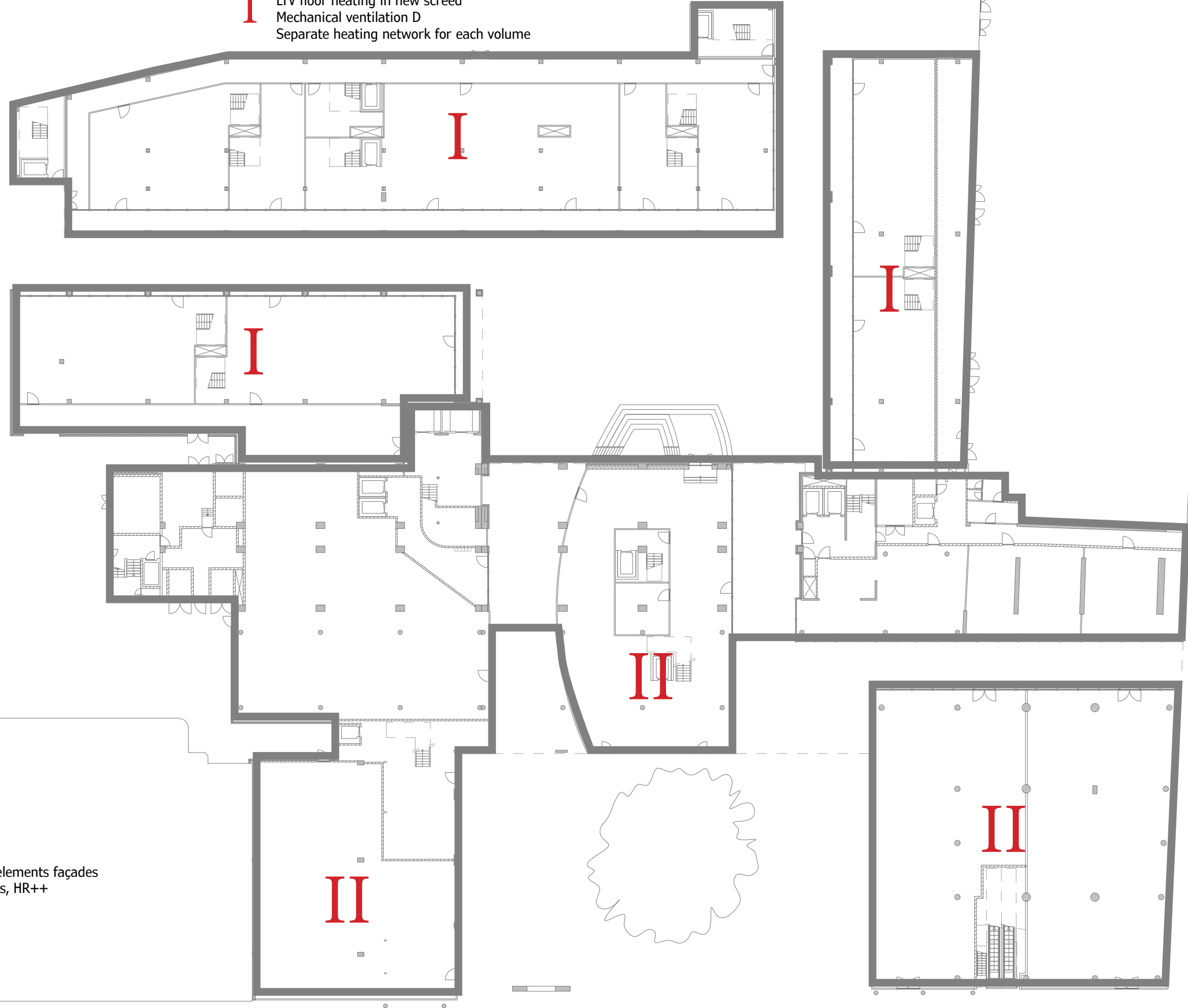

II New insulation behind stone elements façades
New glass & frames in façades, HR++
Heating: Pipes in new screed
Mechanical ventilation D

III New HSB and sandwich façade elements attached to parking garage construction
LTV floor heating in new screed
Ventilation separate for each apartment



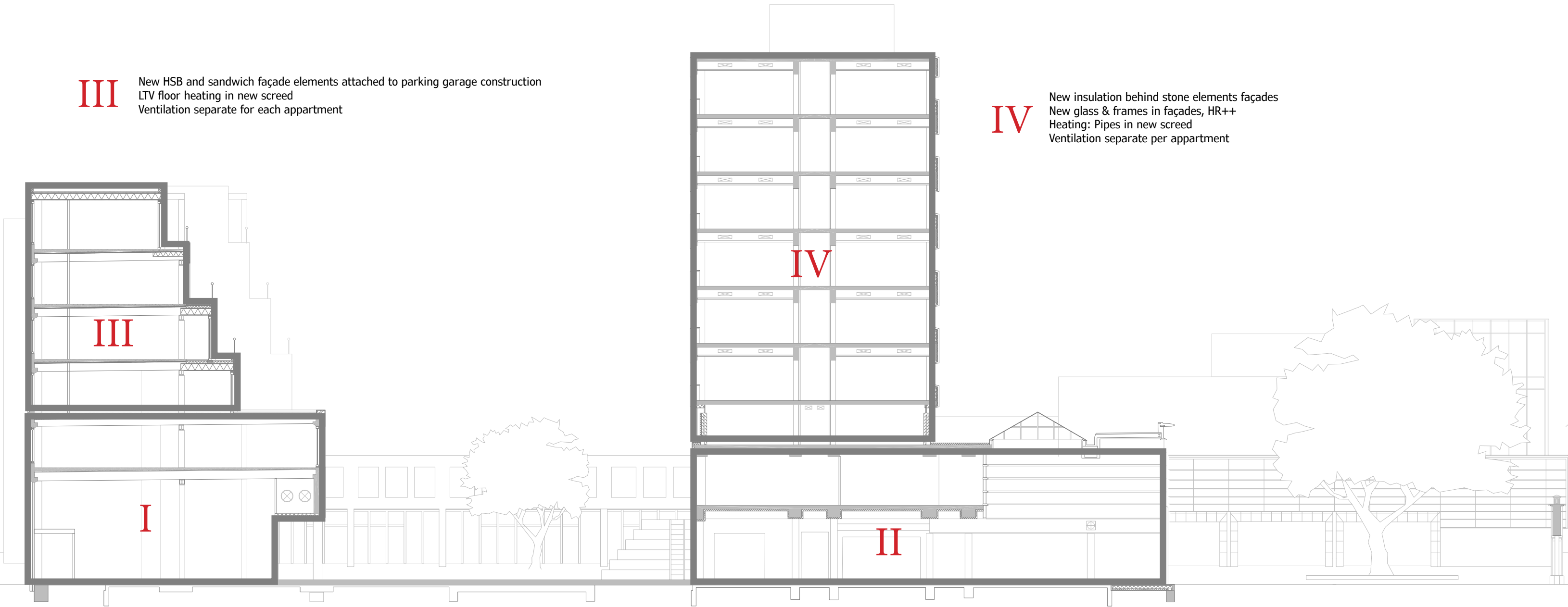



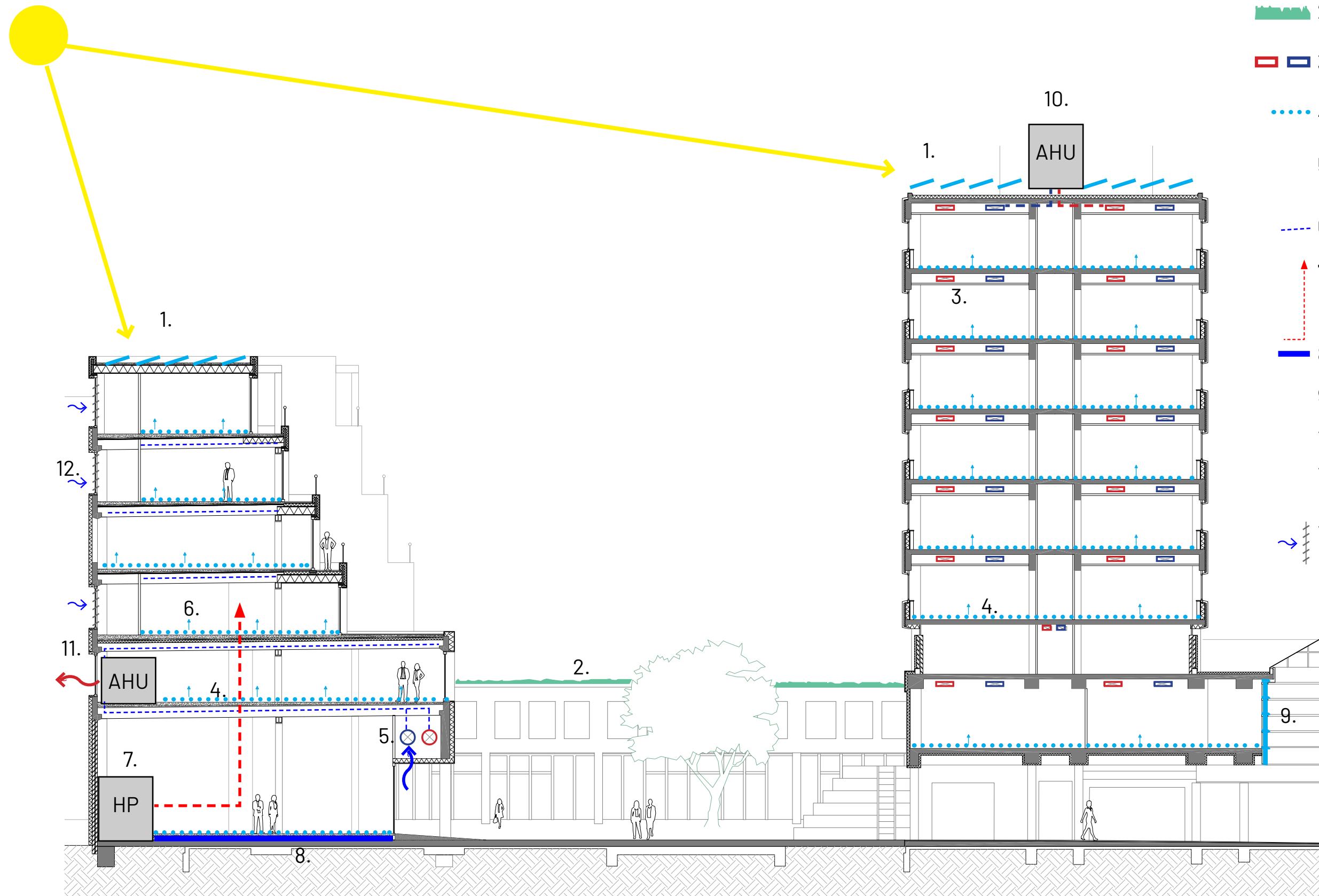

IV New insulation behind stone elements façades
New glass & frames in façades, HR++
Heating: Pipes in new screed
Ventilation separate per apartment



DESIGN

Climatization summer



-  1. PVT Panels on highest roofs: Electricity & housing warm water
-  2. Water retaining green roofs on two lower building volumes
-  3. Lowered ceiling with installation shafts
-  4. Floor cooling
- 5. Installations above arcade, ventilation input
-  6. Installations between TT-floor ribs
-  7. Cooling powered by pvt panels on the roof. Residual heat of installations to warm water housing via shafts
-  8. Piping in ground floor insulation
- 9. Improved HR++ glazing in façade
- 10. AHU with heat recovery for tower
- 11. AHU with heat recovery for retail, ventilation output
-  12. Automatically opened window at southern oriented gallery

DESIGN

Climatization winter

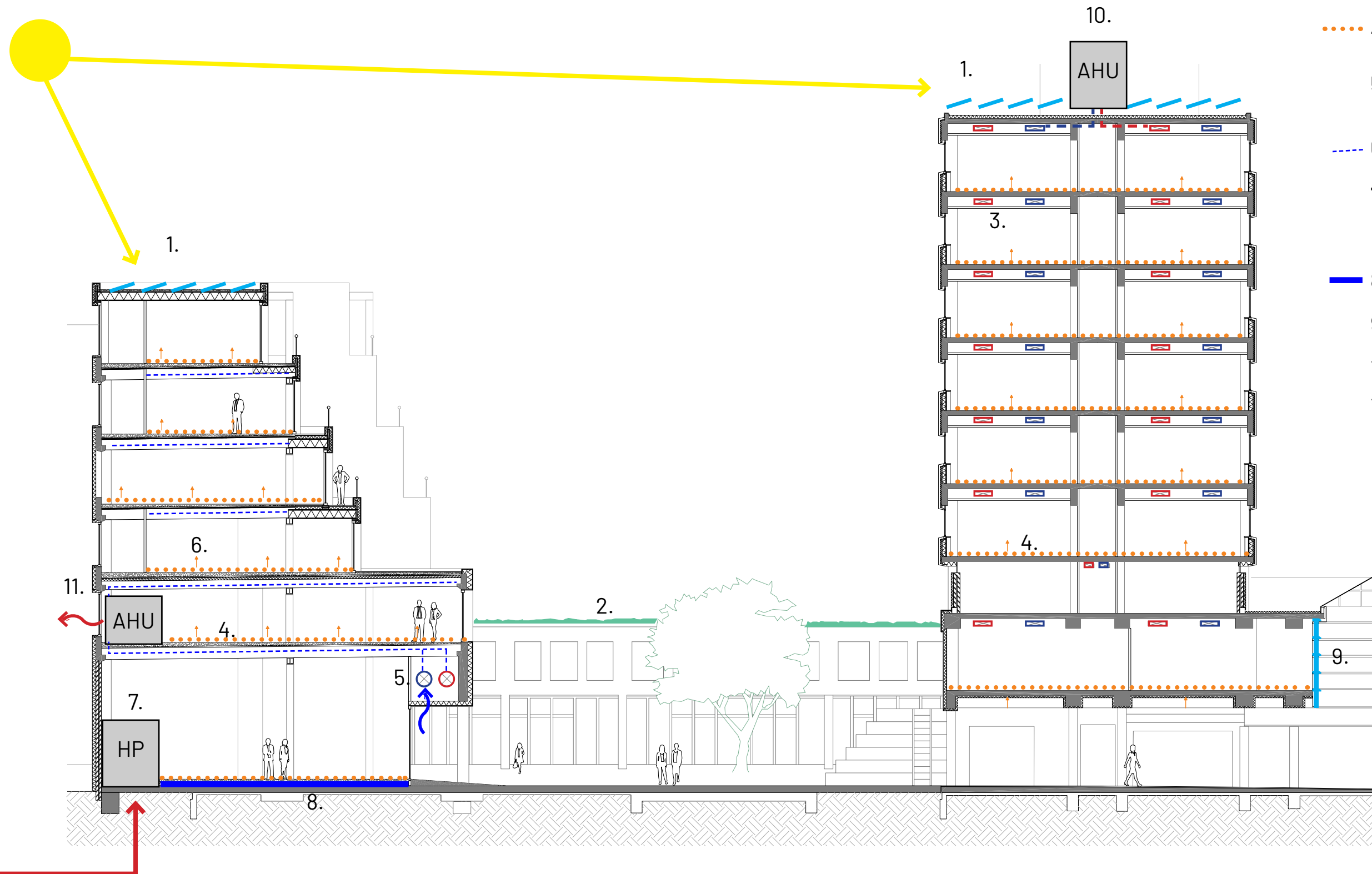

- 1. PVT Panels on highest roofs: Electricity & housing warm water
- 2. Water retaining green roofs on two lower building volumes
- □ 3. Lowered ceiling with installation shafts
- 4. Floor heating
- 5. Installations above arcade, ventilation input
- - - 6. Installations between TT-floor ribs
- 7. Heating via heat pump connected to city heating network (MT/HT)
- 8. Piping in ground floor insulation
- 9. Improved HR++ glazing in façade
- 10. AHU with heat recovery for tower
- 11. AHU with heat recovery for retail, ventilation output

DESIGN

Roof surface

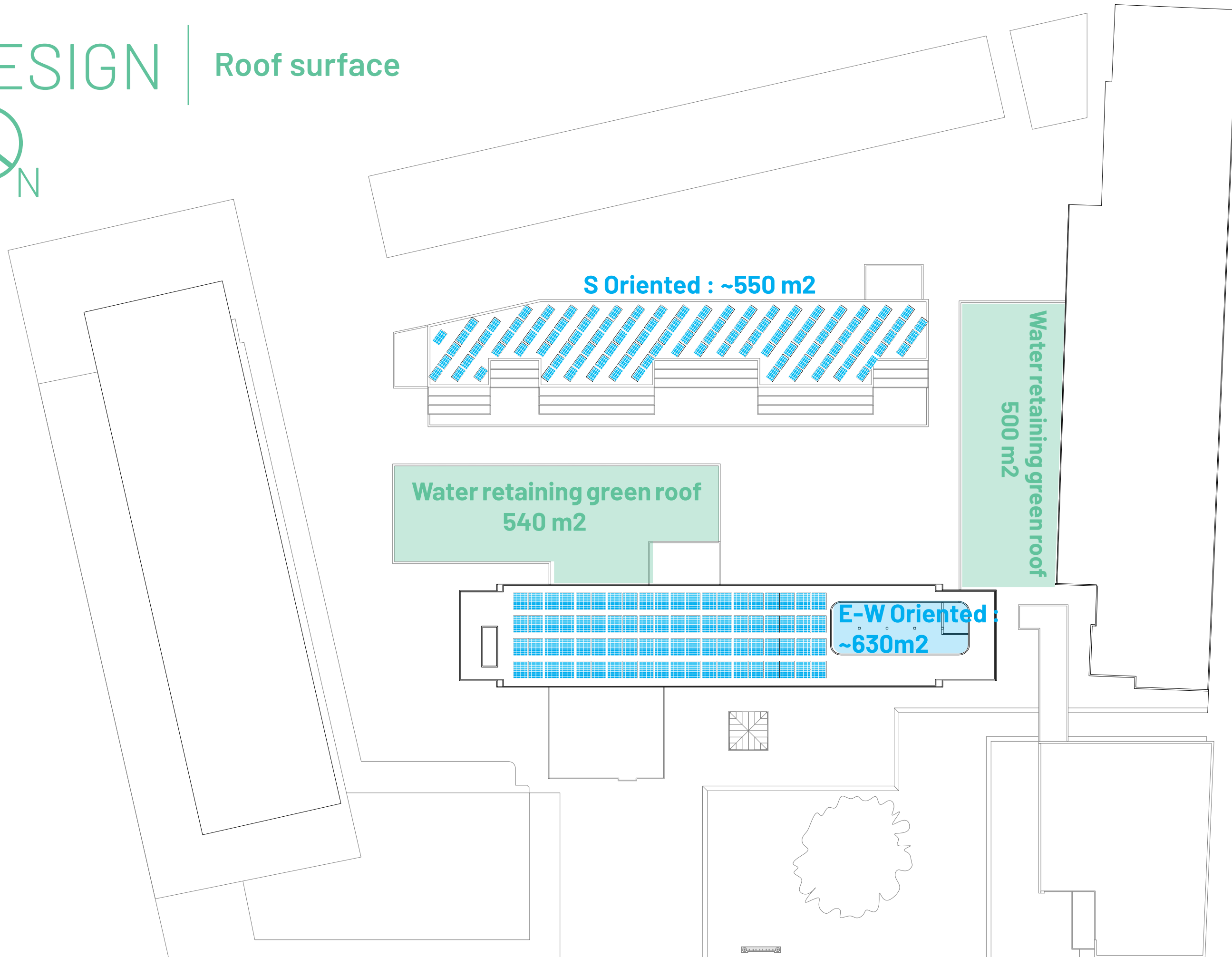

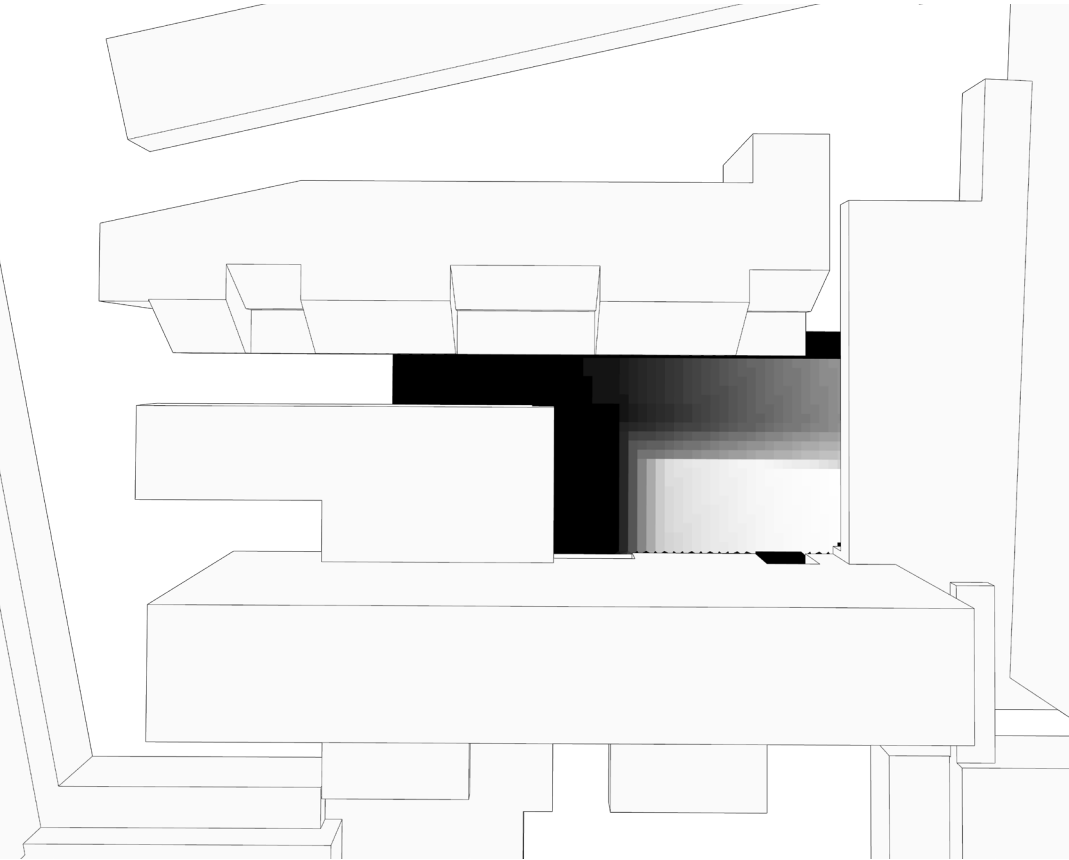

January - March

6444 hours

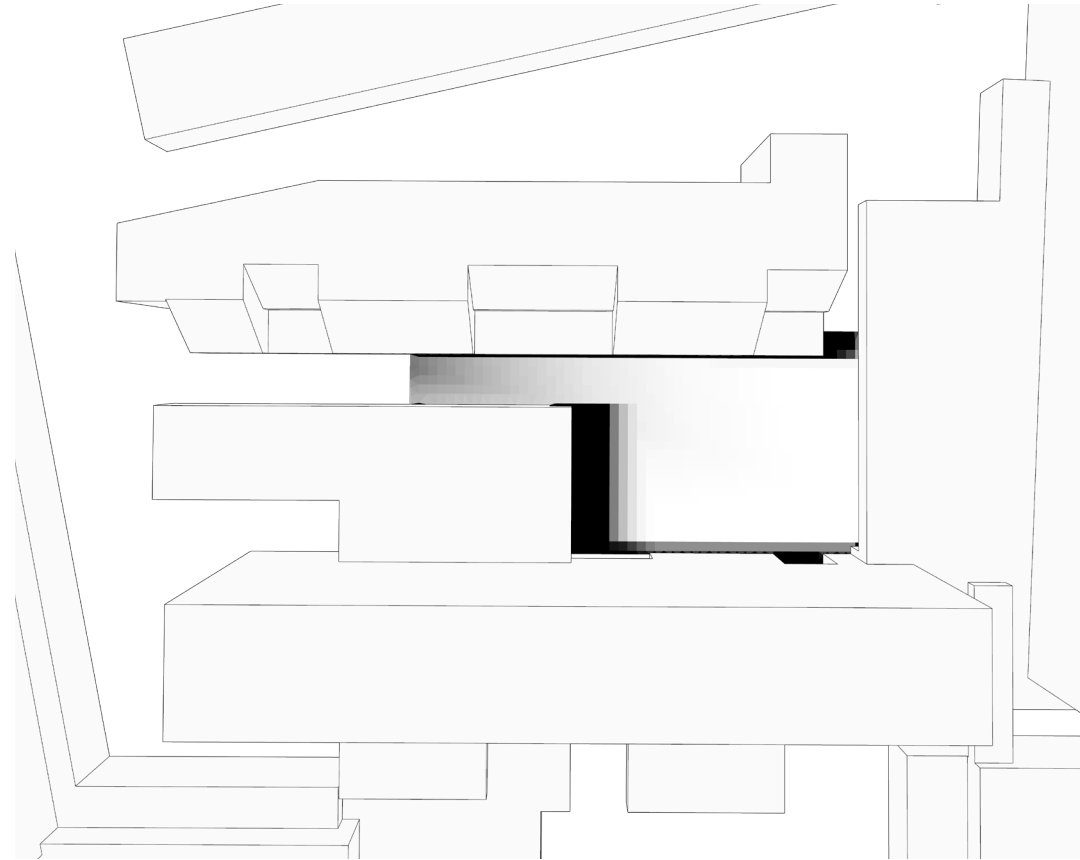

June - August

83616 hours

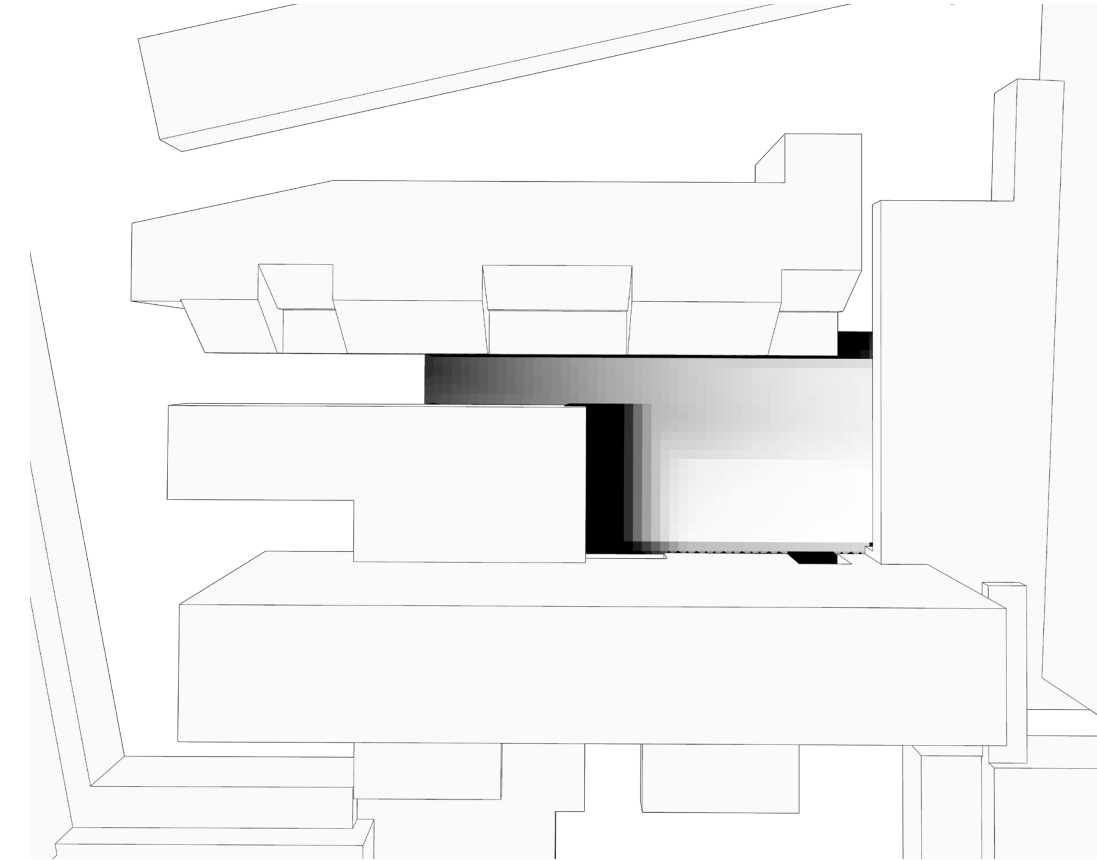

All year

130000

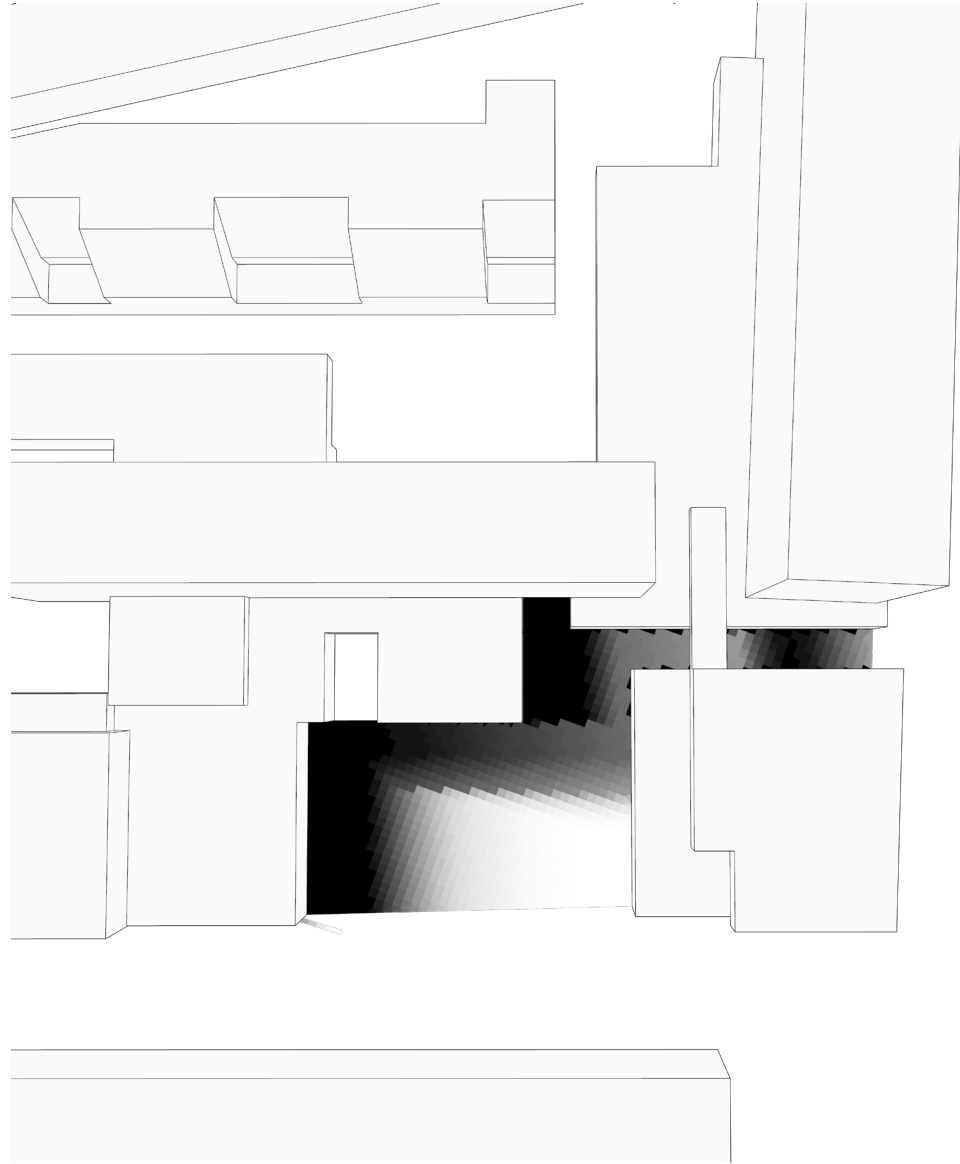

January - March

48700 hours

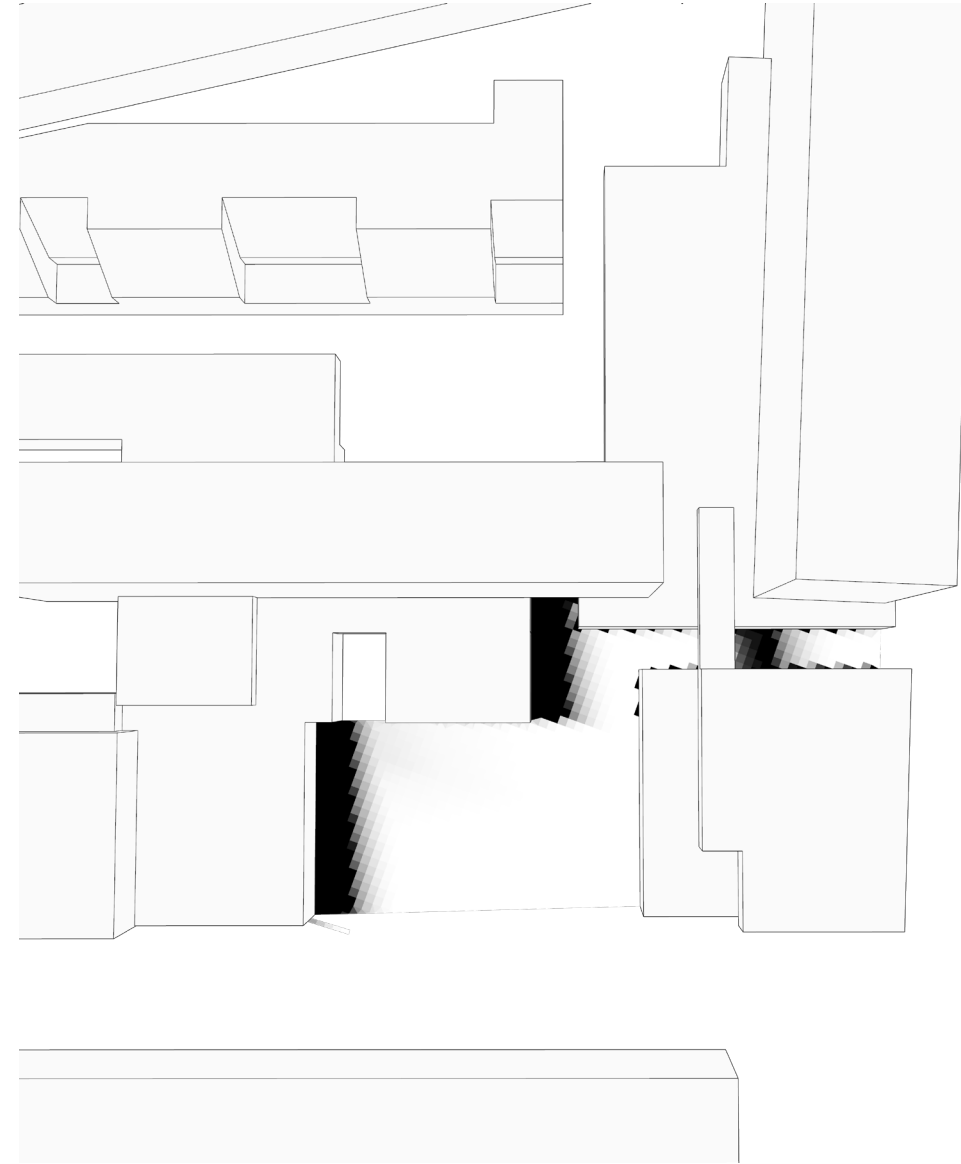

June - August

121215 hours

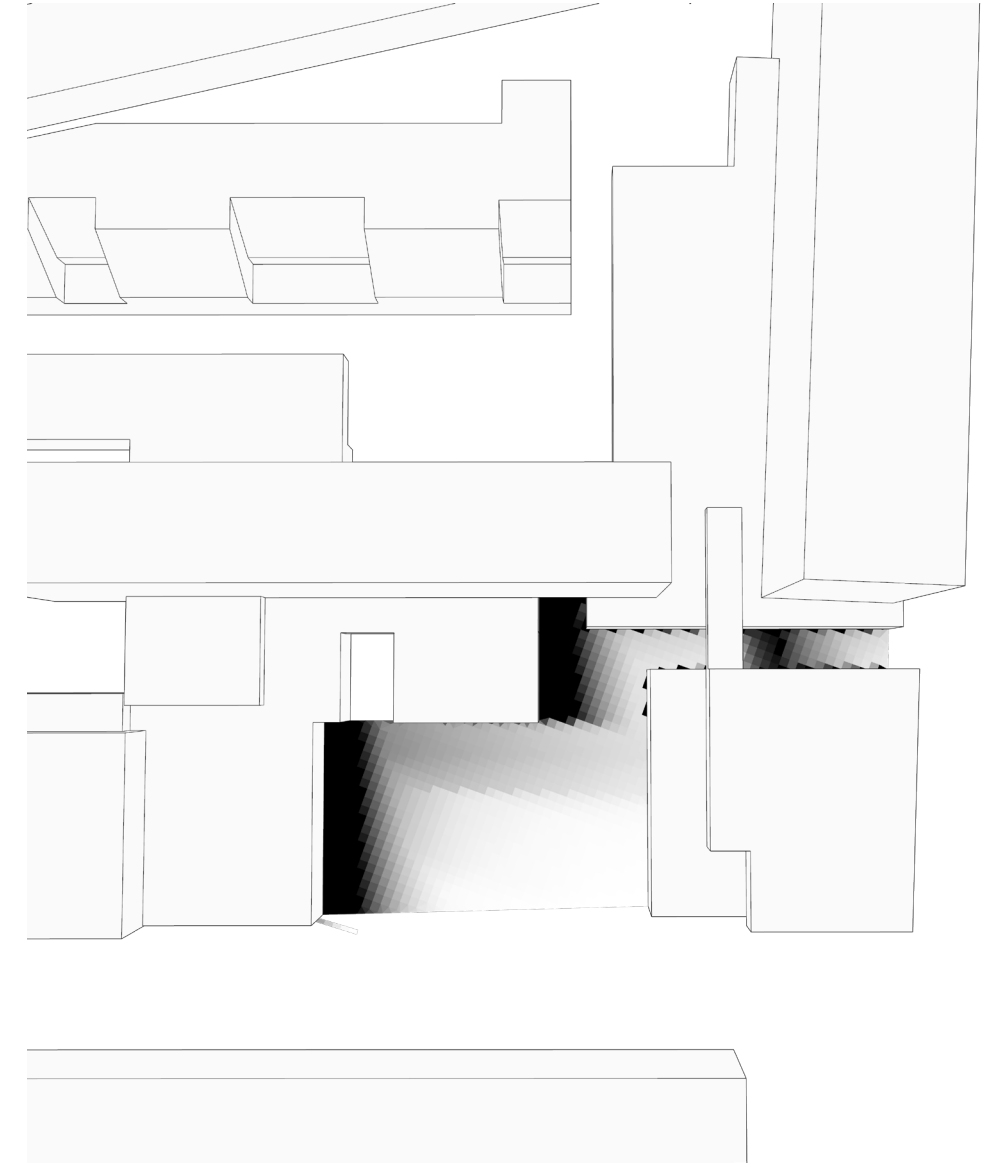

All year

205771 hours

DESIGN

Store climatization

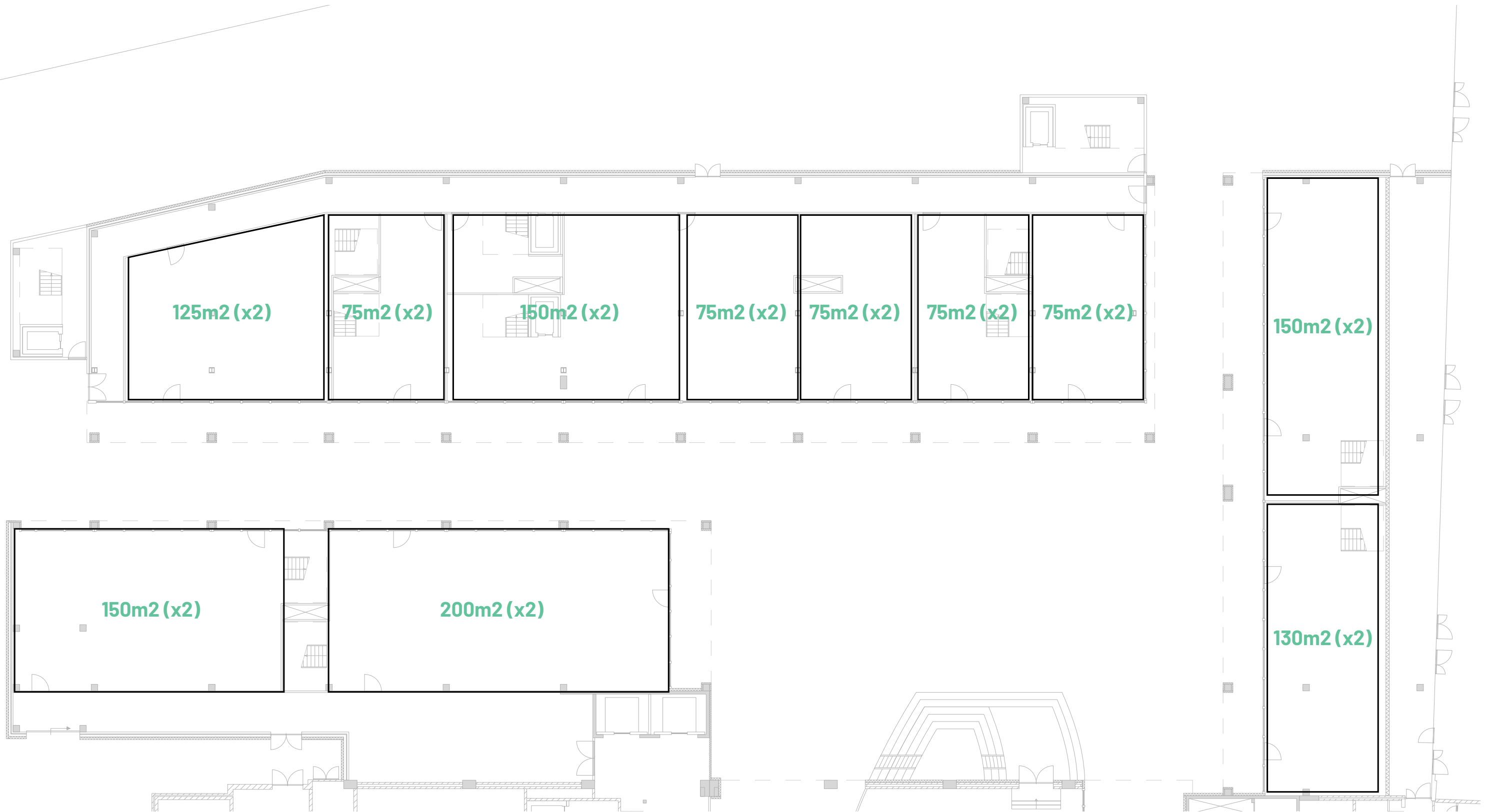

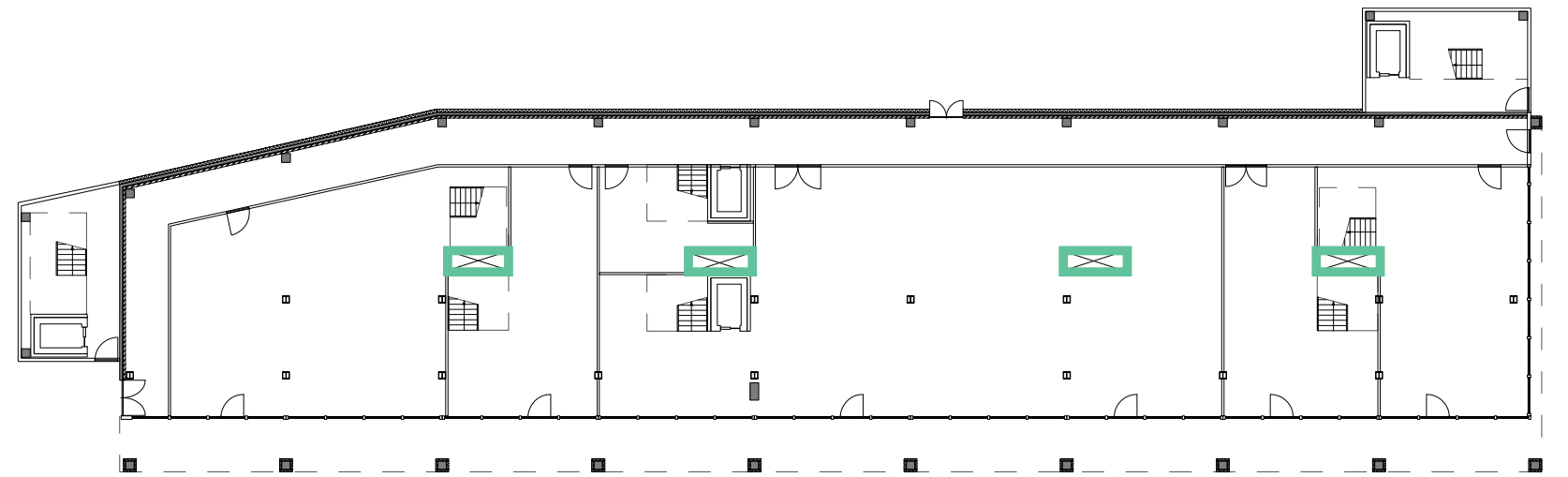
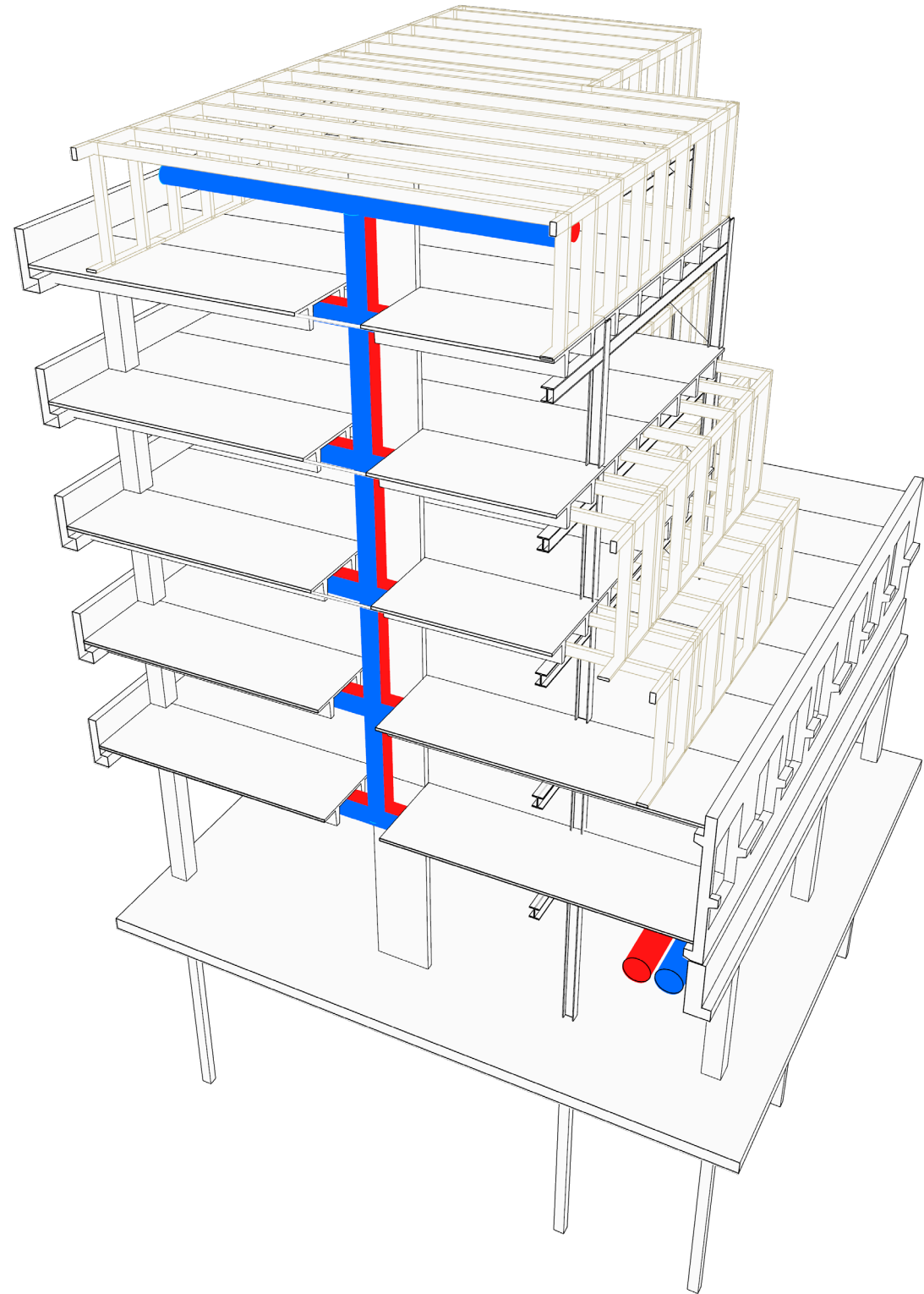

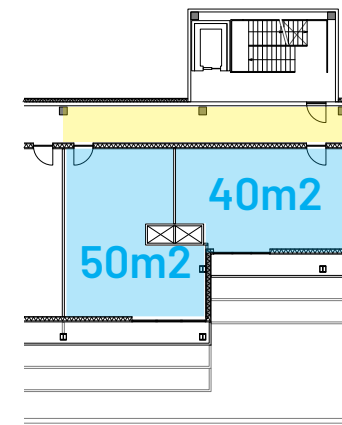
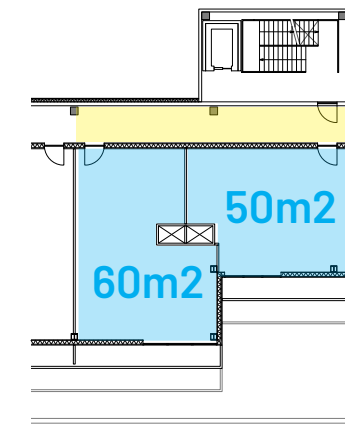
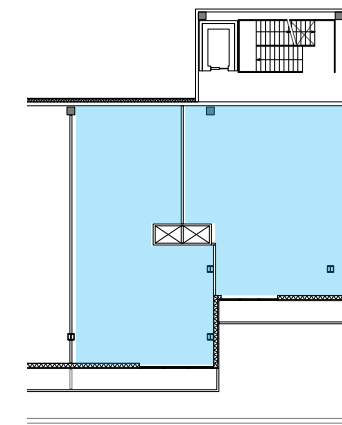
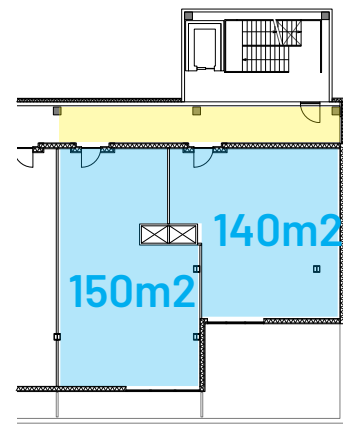
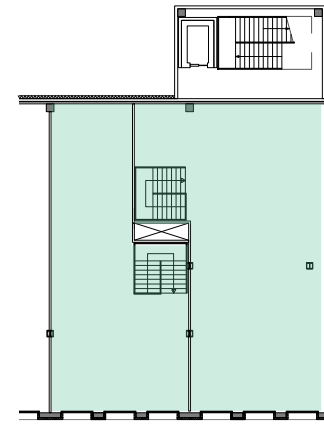
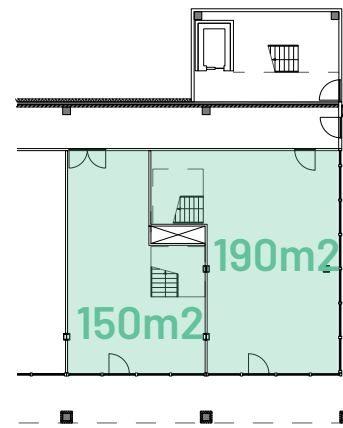
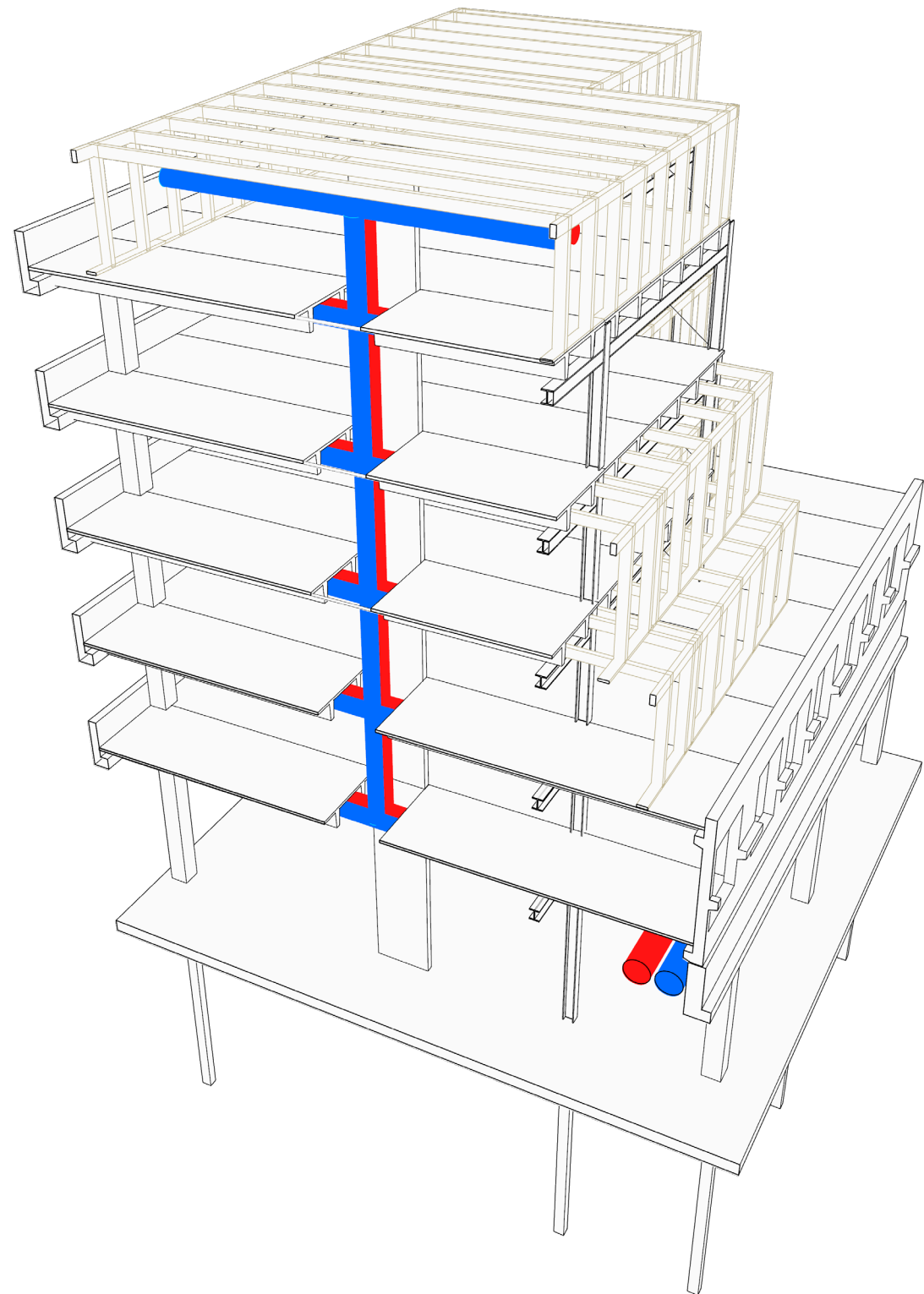

Ventilation demands:
 3,6 m³/hour/m² for housing, 15 m³/hour/m² for hospitality (for peak calculation)

2x retail store 150m² and 190m²

2x maisonette 150m² and 140m²

4x studio 60m², 50m², 50m², 40m²

Flow rate = $3,6 \cdot 490 + 15 \cdot 340 = 6864 \text{ m}^3/\text{hour} = 1,9 \text{ m}^3/\text{s}$

Air speed in shaft = 5m/s

Required surface area shaft = $1,9 / 5 = 0,38 \text{ m}^2$

Radius of 1 ventilation shaft = $\sqrt{(0,38 / \pi)} = 0,35 \text{ m}$

Diameter = 0,7 m

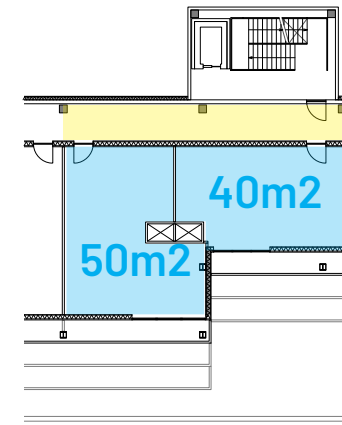
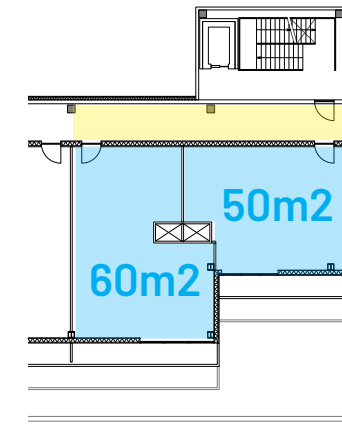
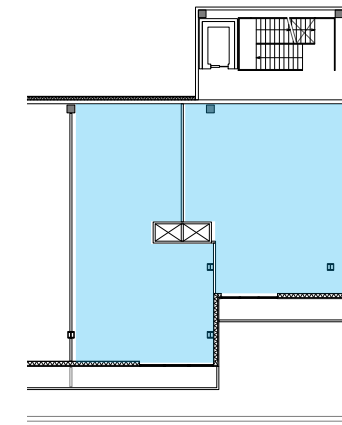
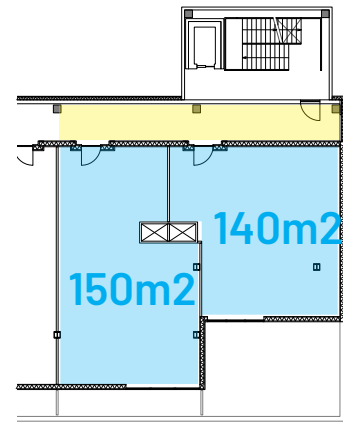
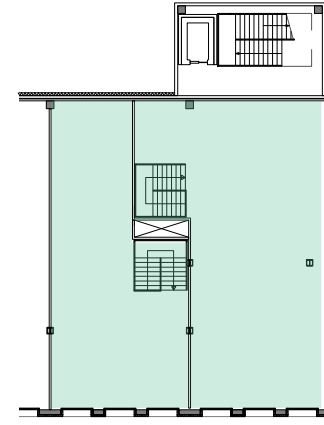
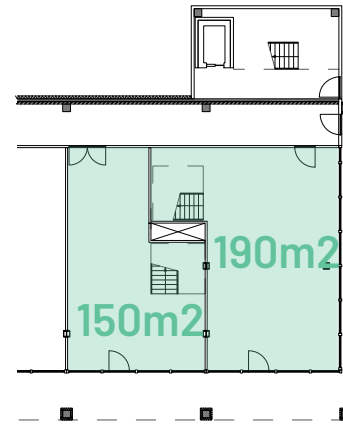
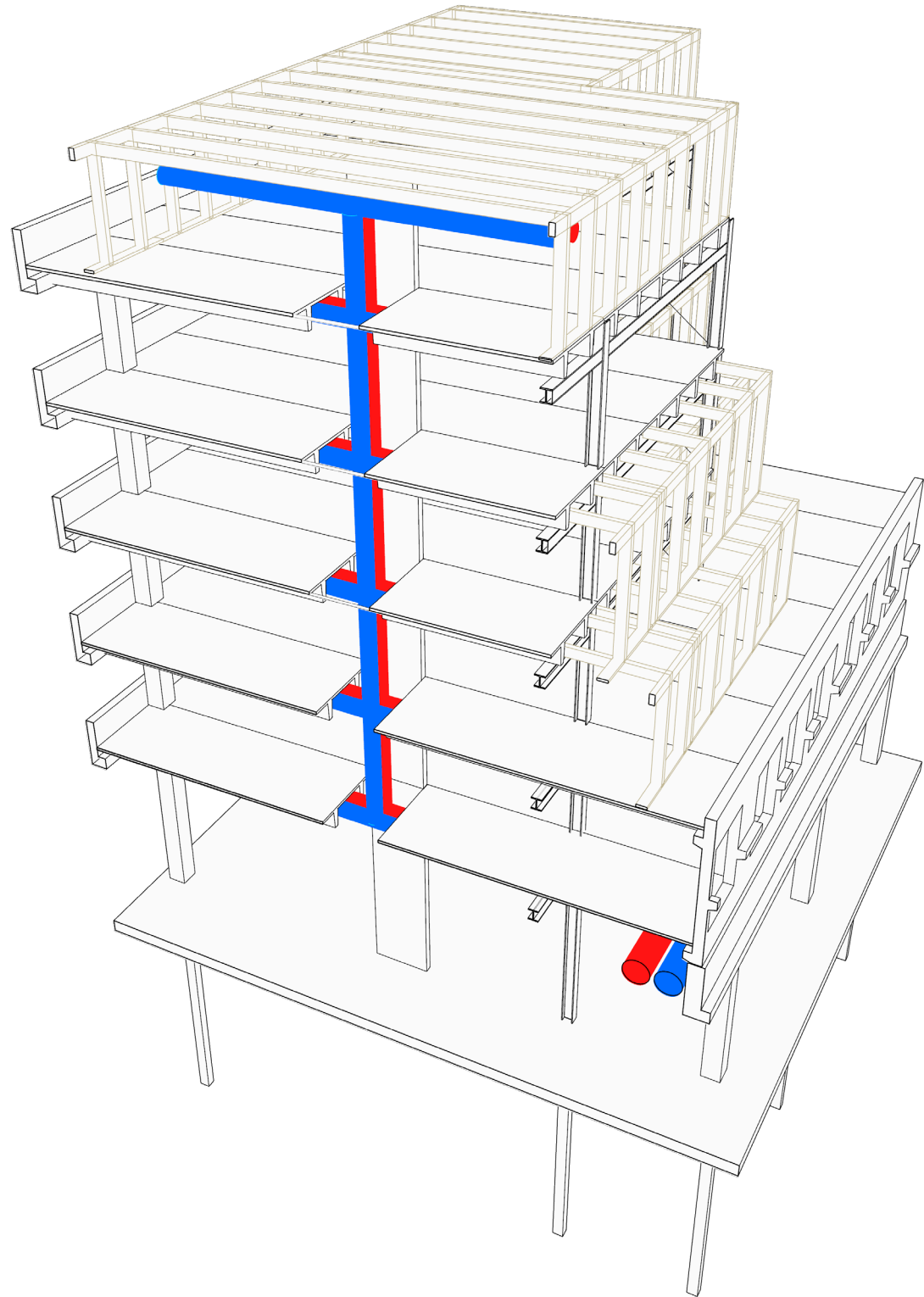

Diameter = 700mm

2 canals in shaft

Shaft measurement = 2400mm (width of TT-floor) by 1000mm

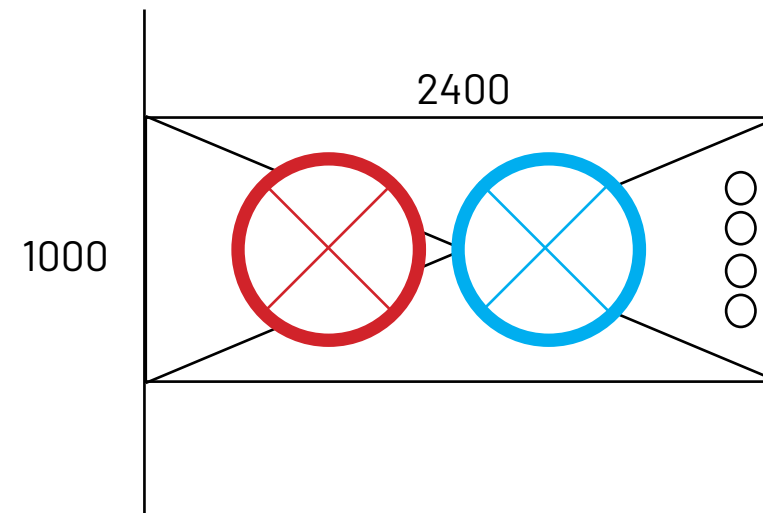

DESIGN

Ventilation & Installations

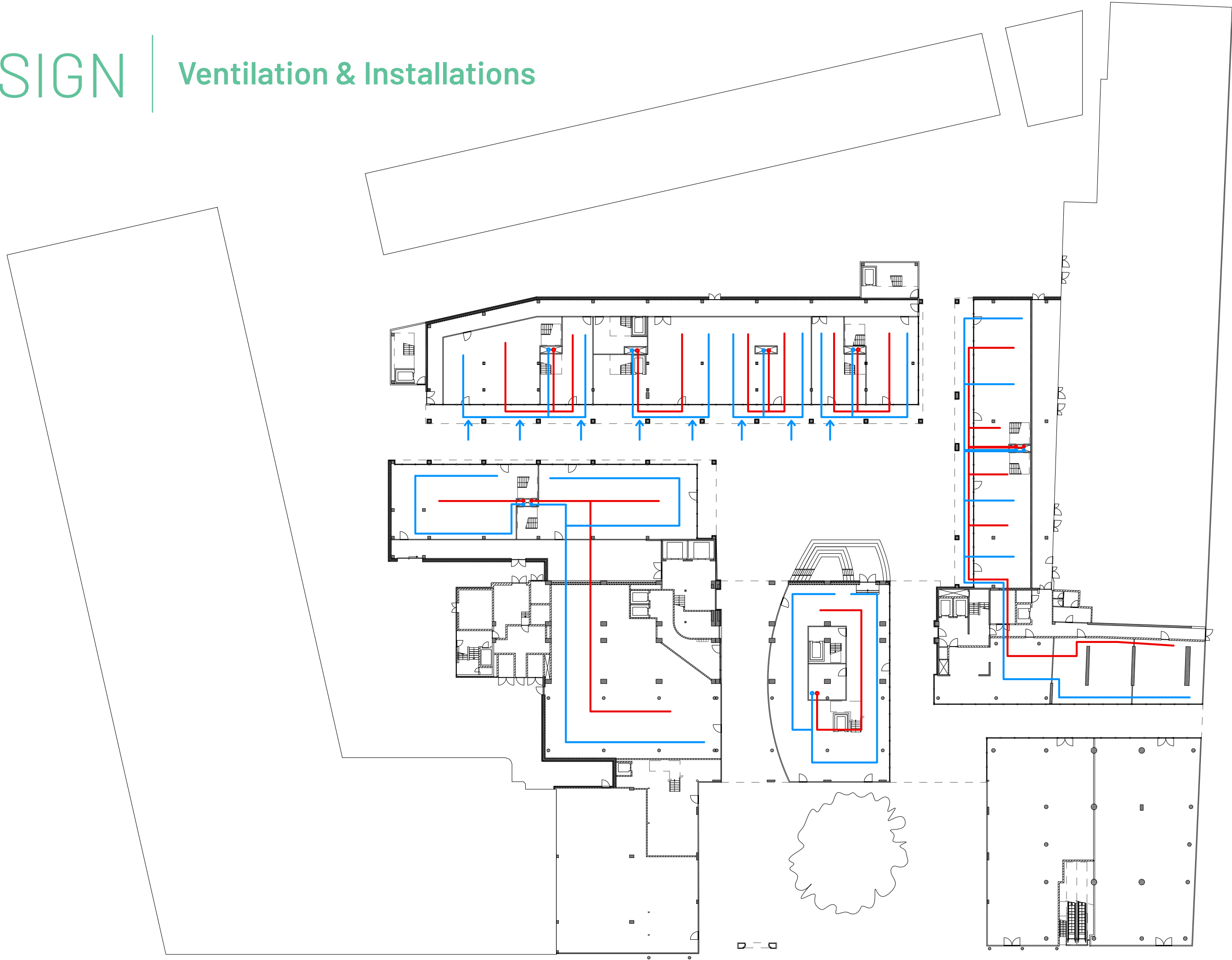

DESIGN

Ventilation & Installations

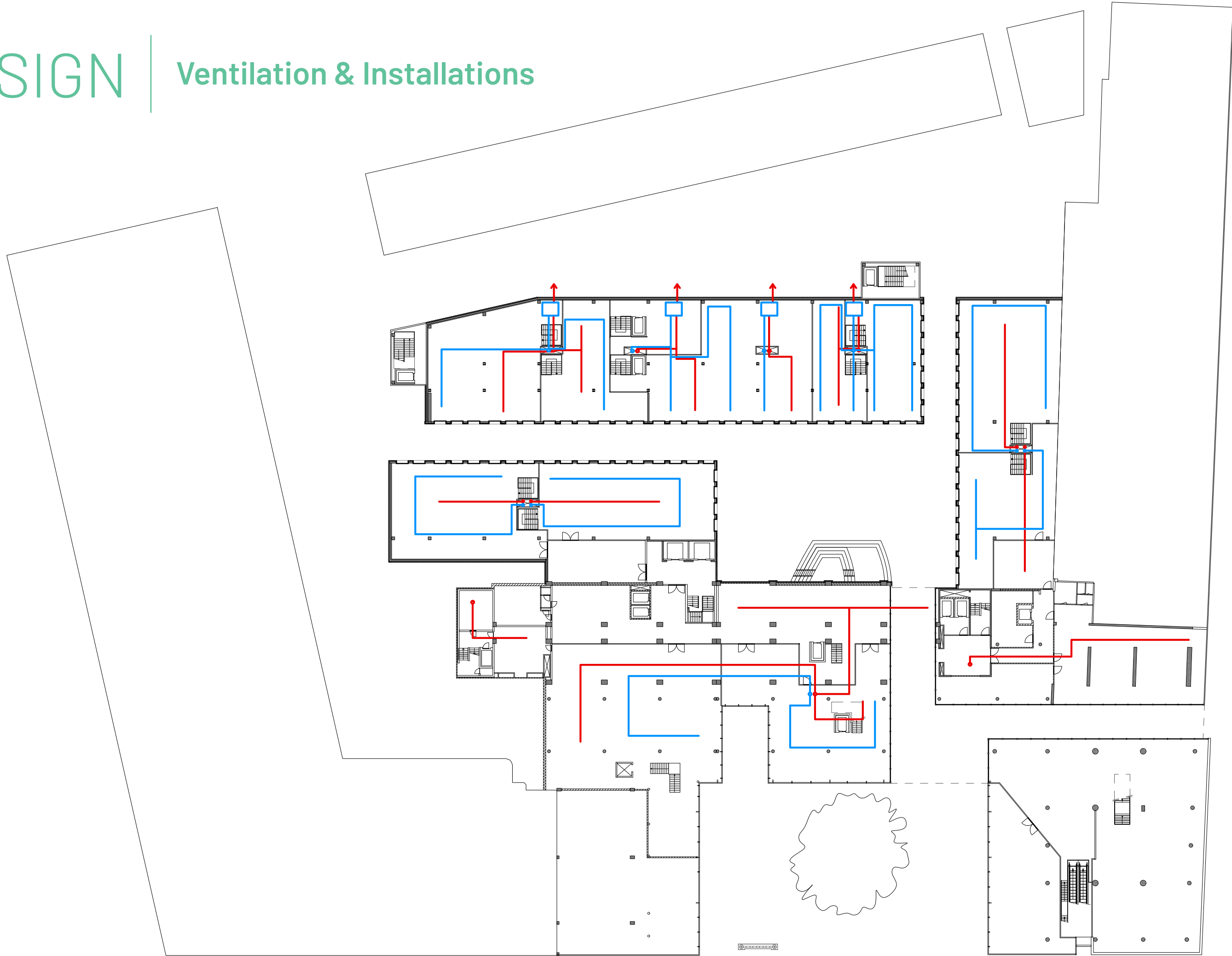

DESIGN

Ventilation & Installations

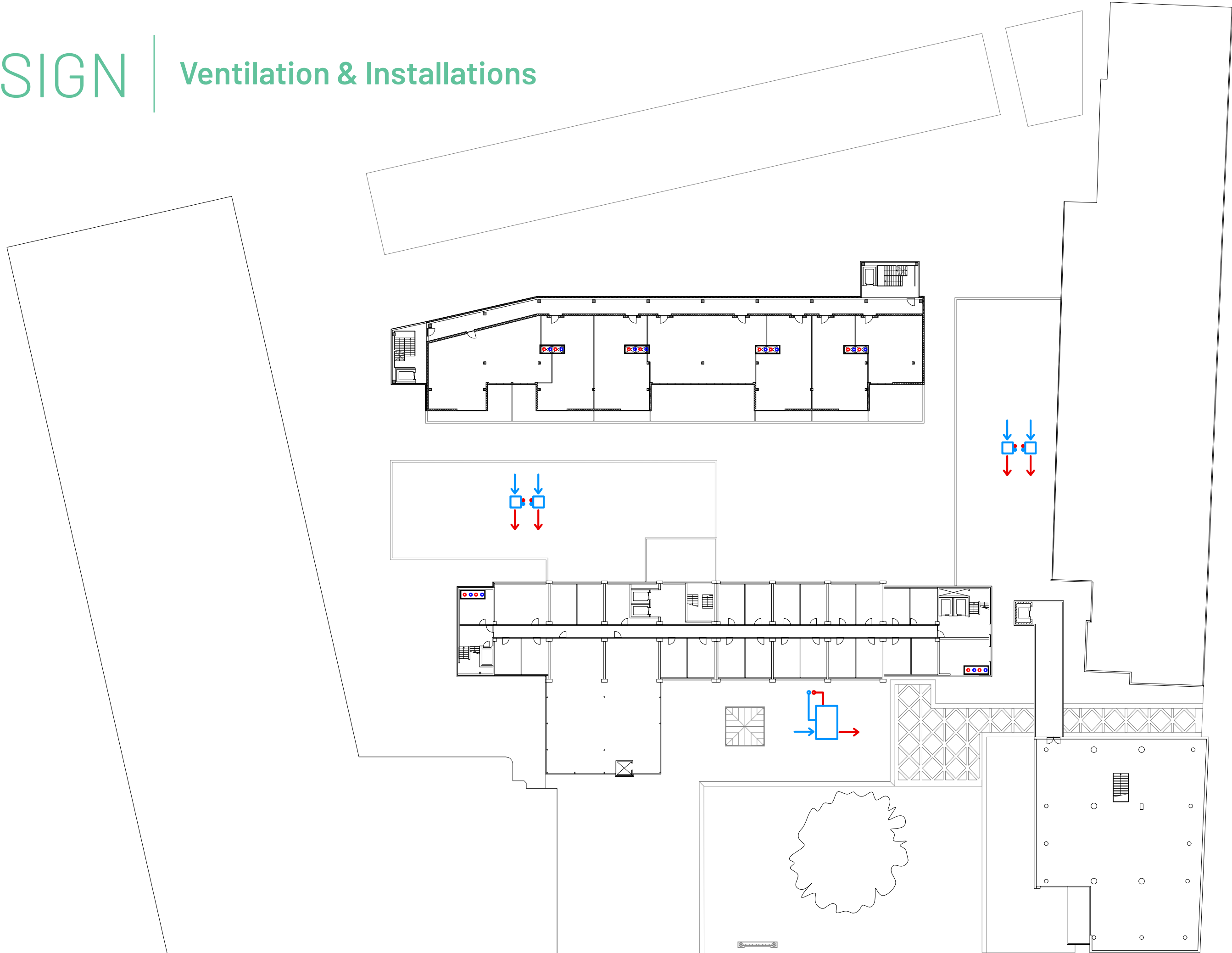

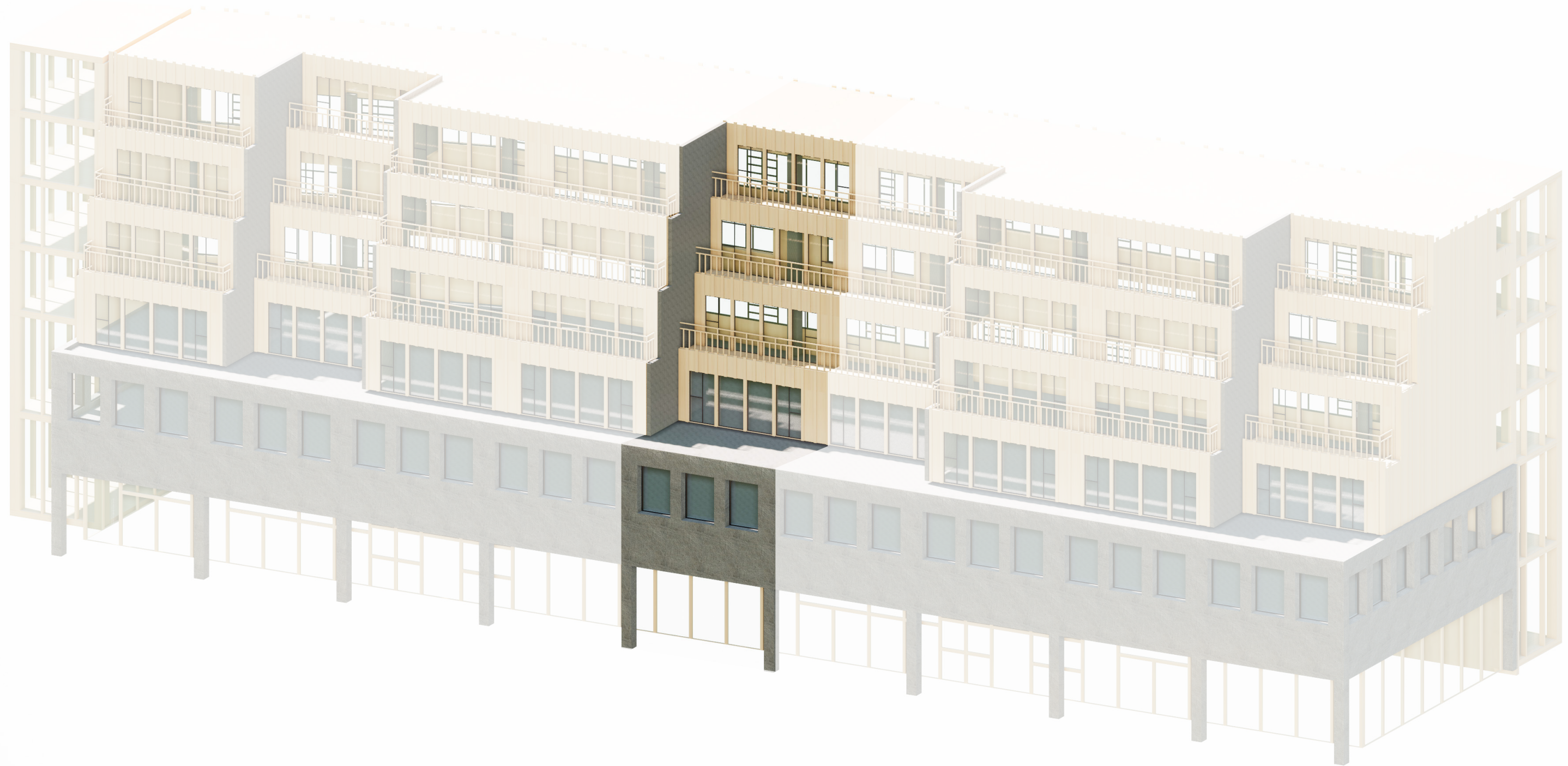

DESIGN

Façade fragm

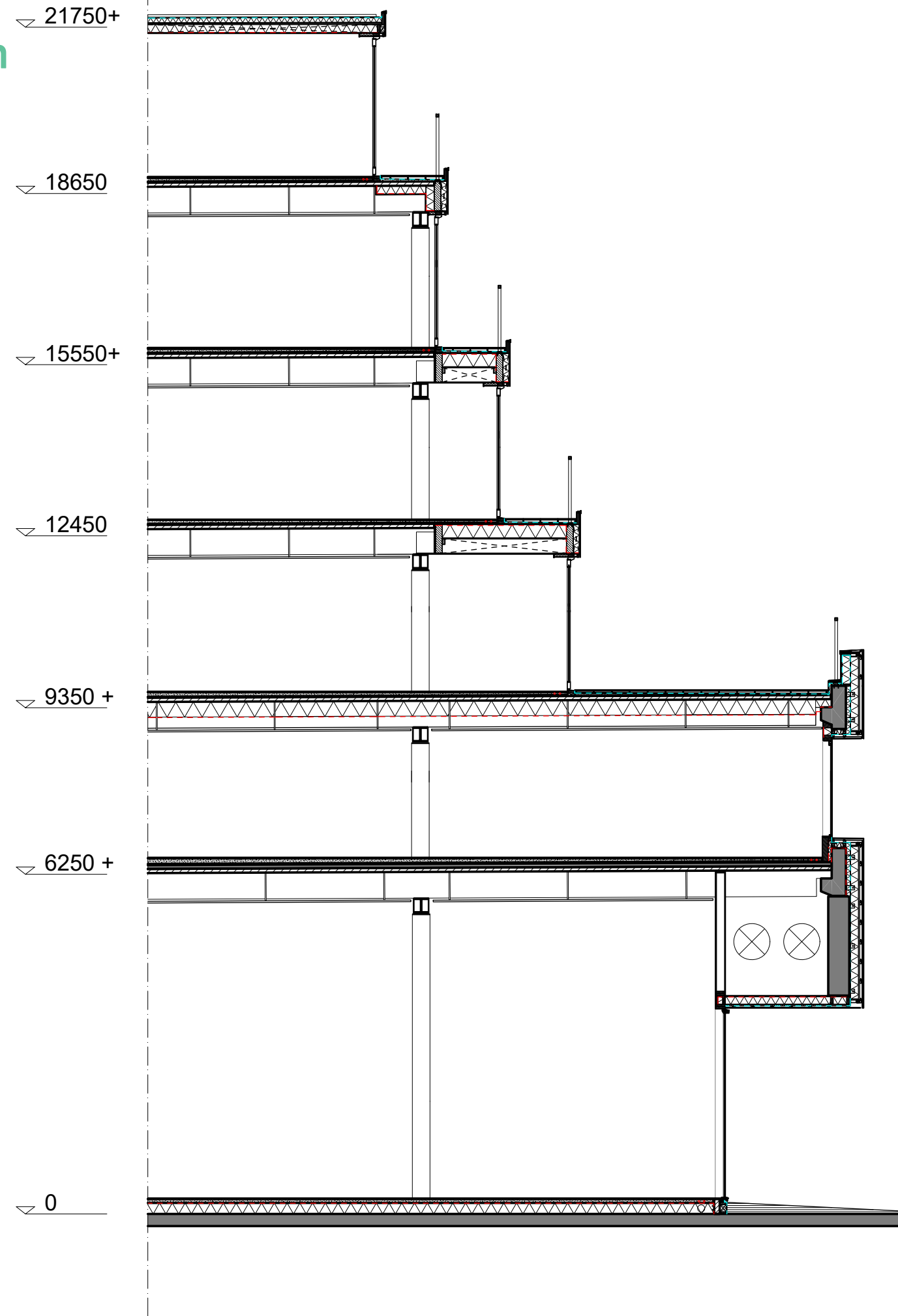
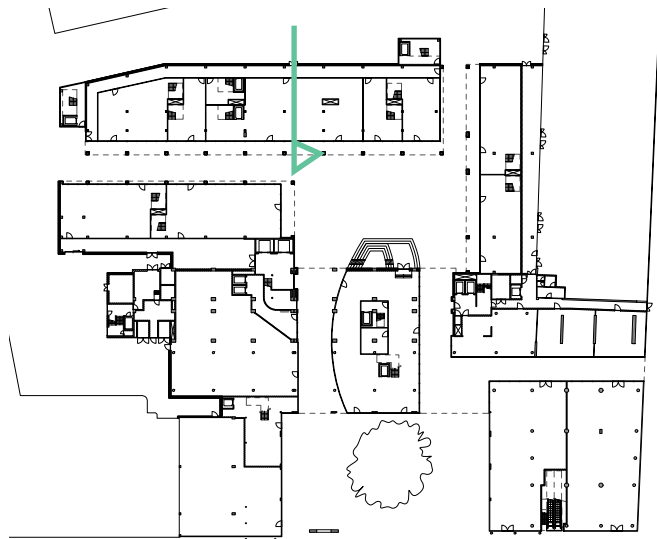

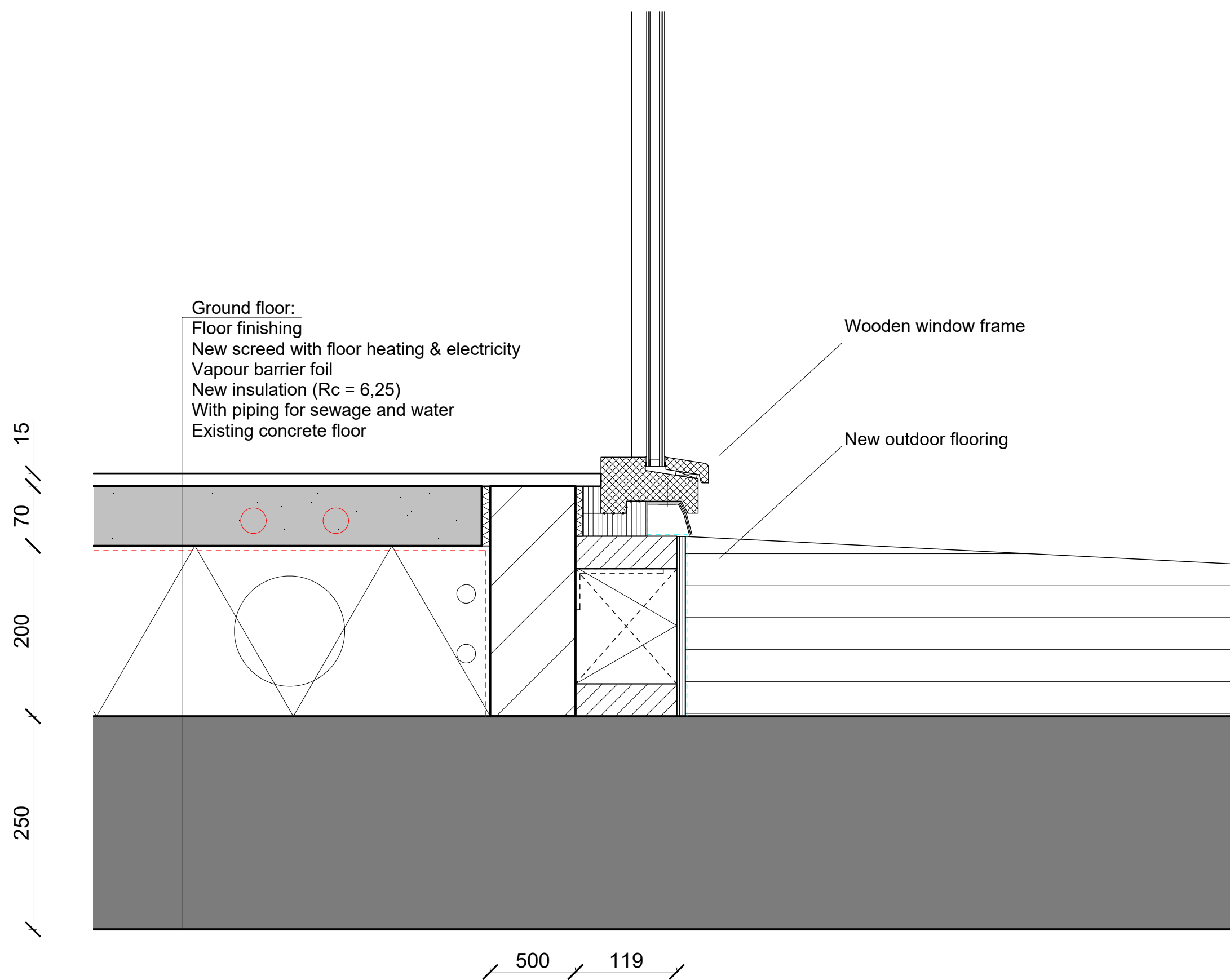
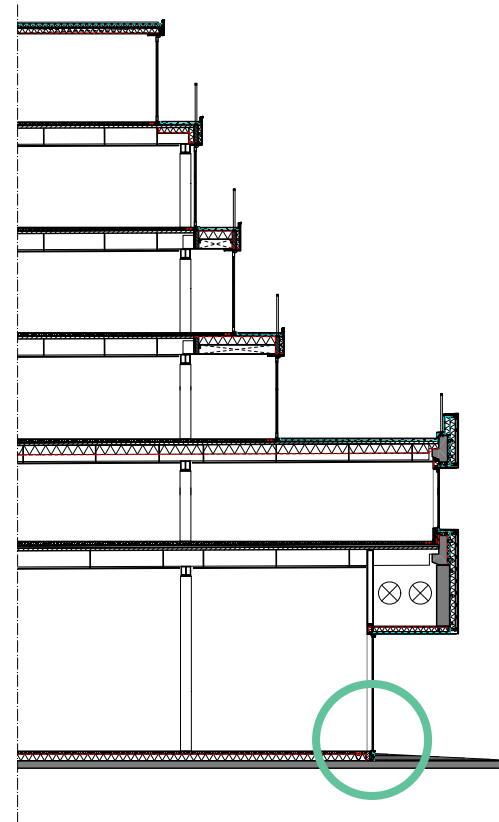

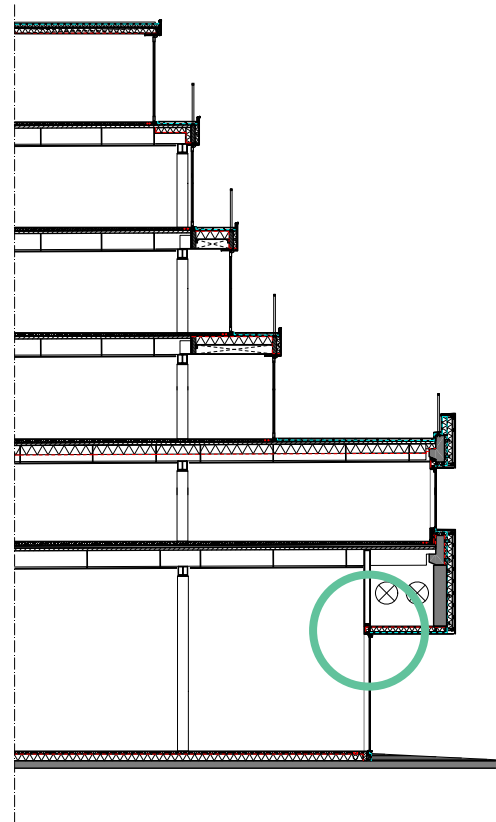

Wooden window frame

Insulated glazing

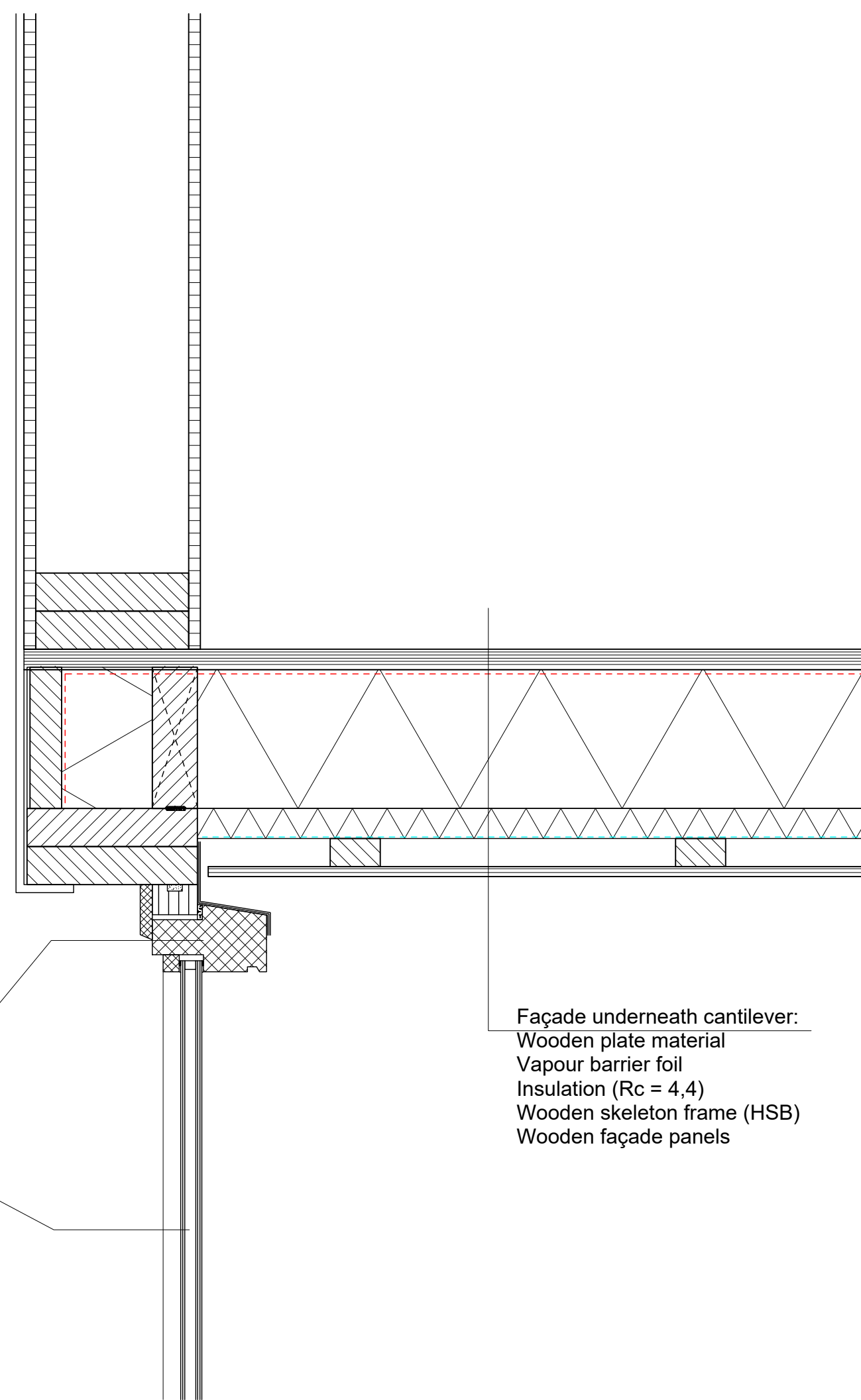

Façade underneath cantilever:
Wooden plate material
Vapour barrier foil
Insulation ($R_c = 4,4$)
Wooden skeleton frame (HSB)
Wooden façade panels

20
140
30/30
10

DESIGN

Details

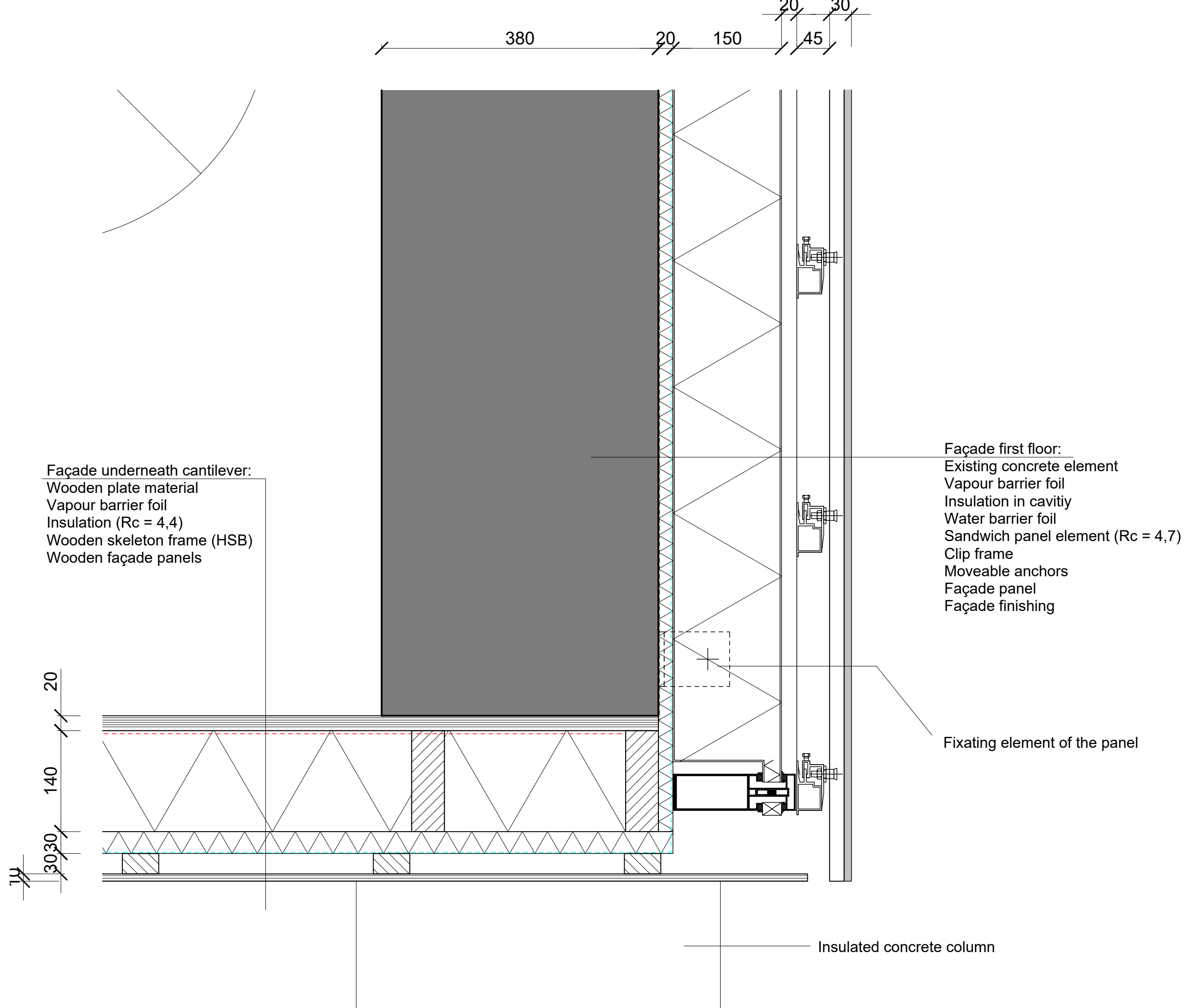
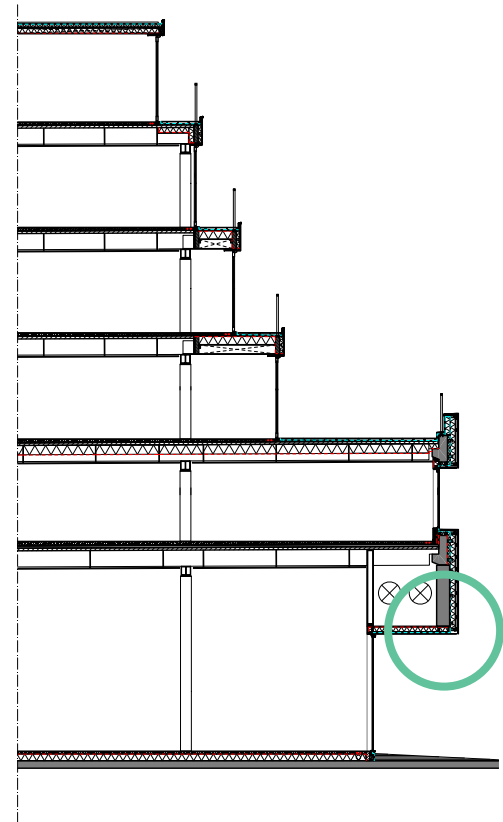

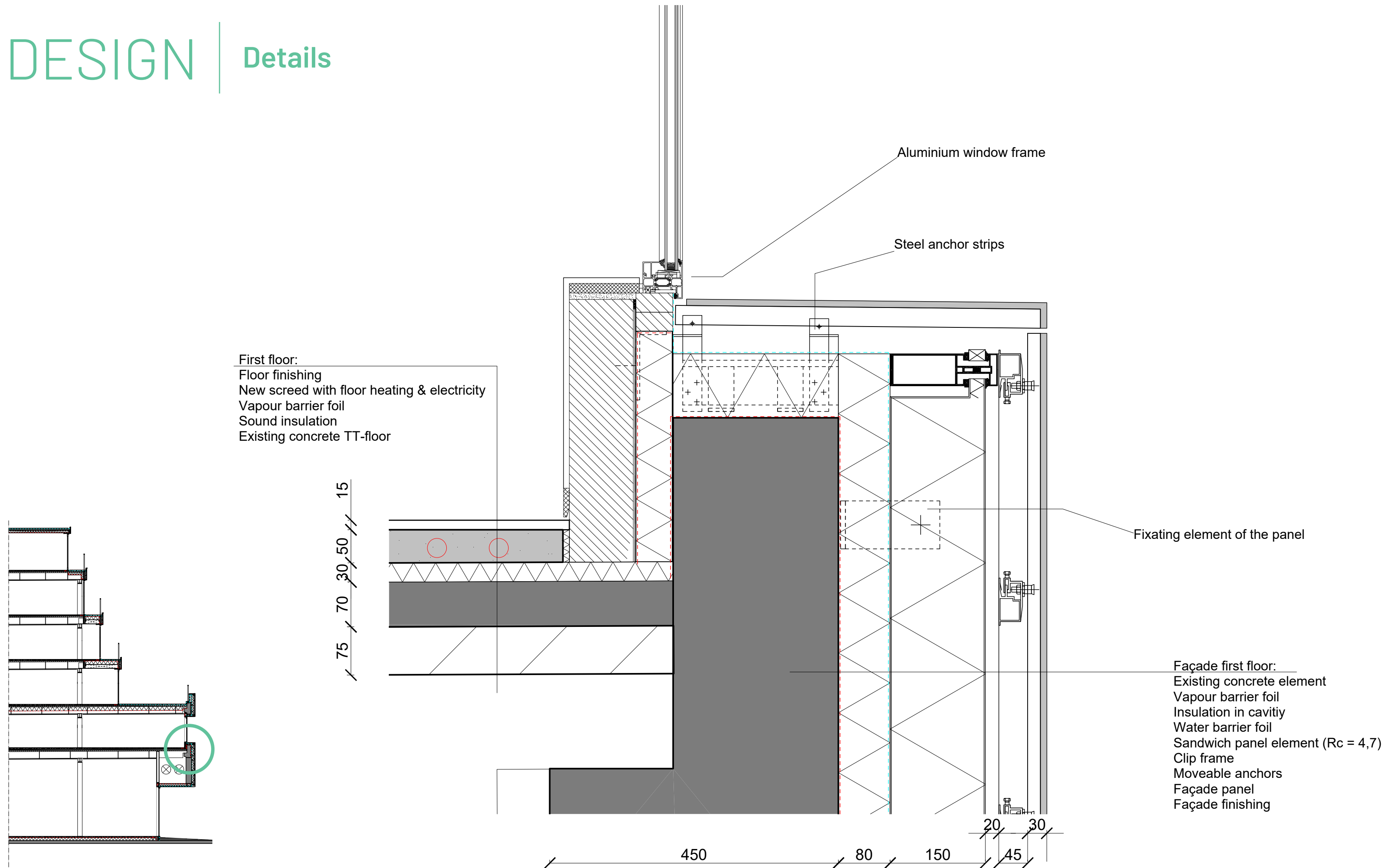

DESIGN

Details

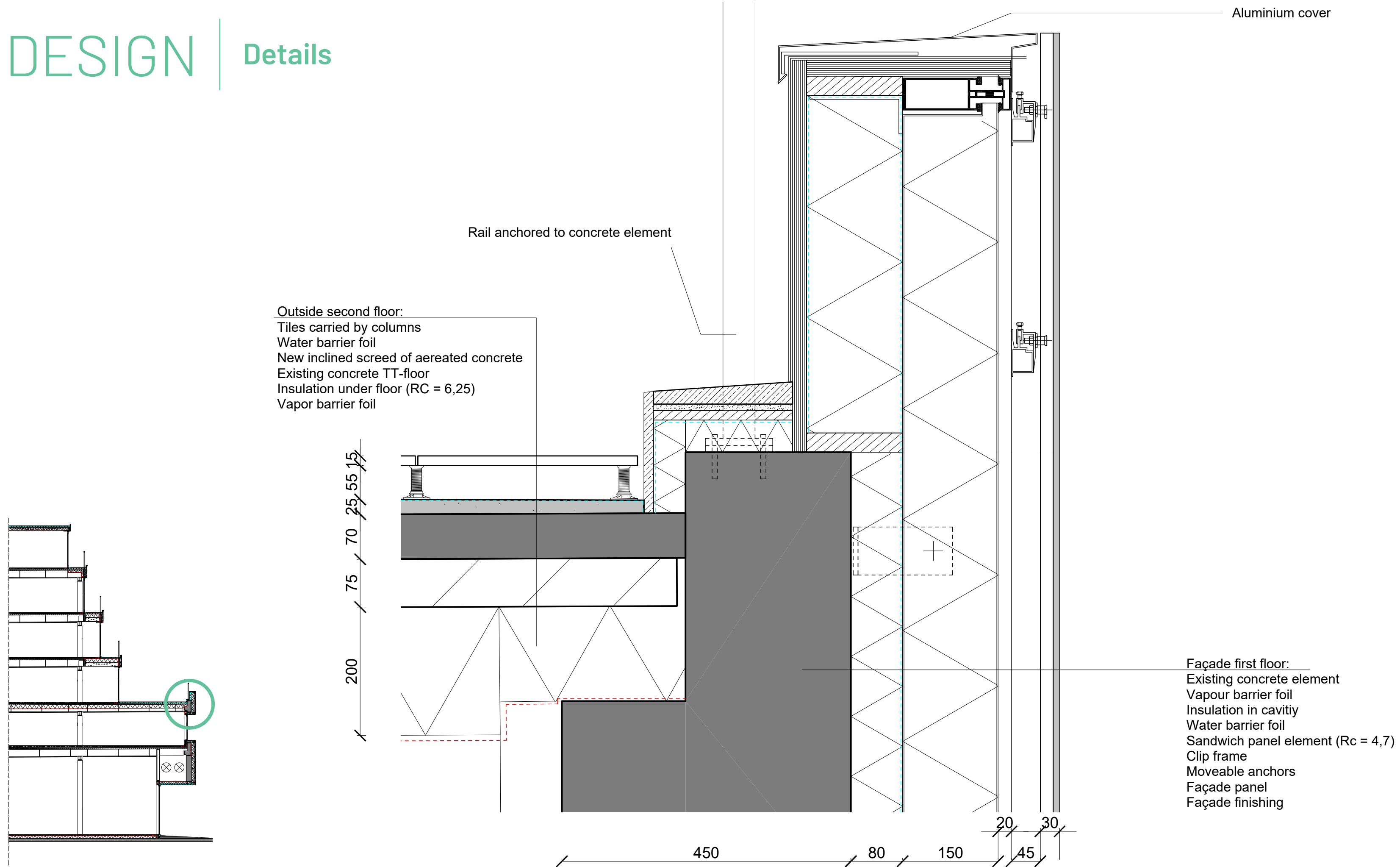

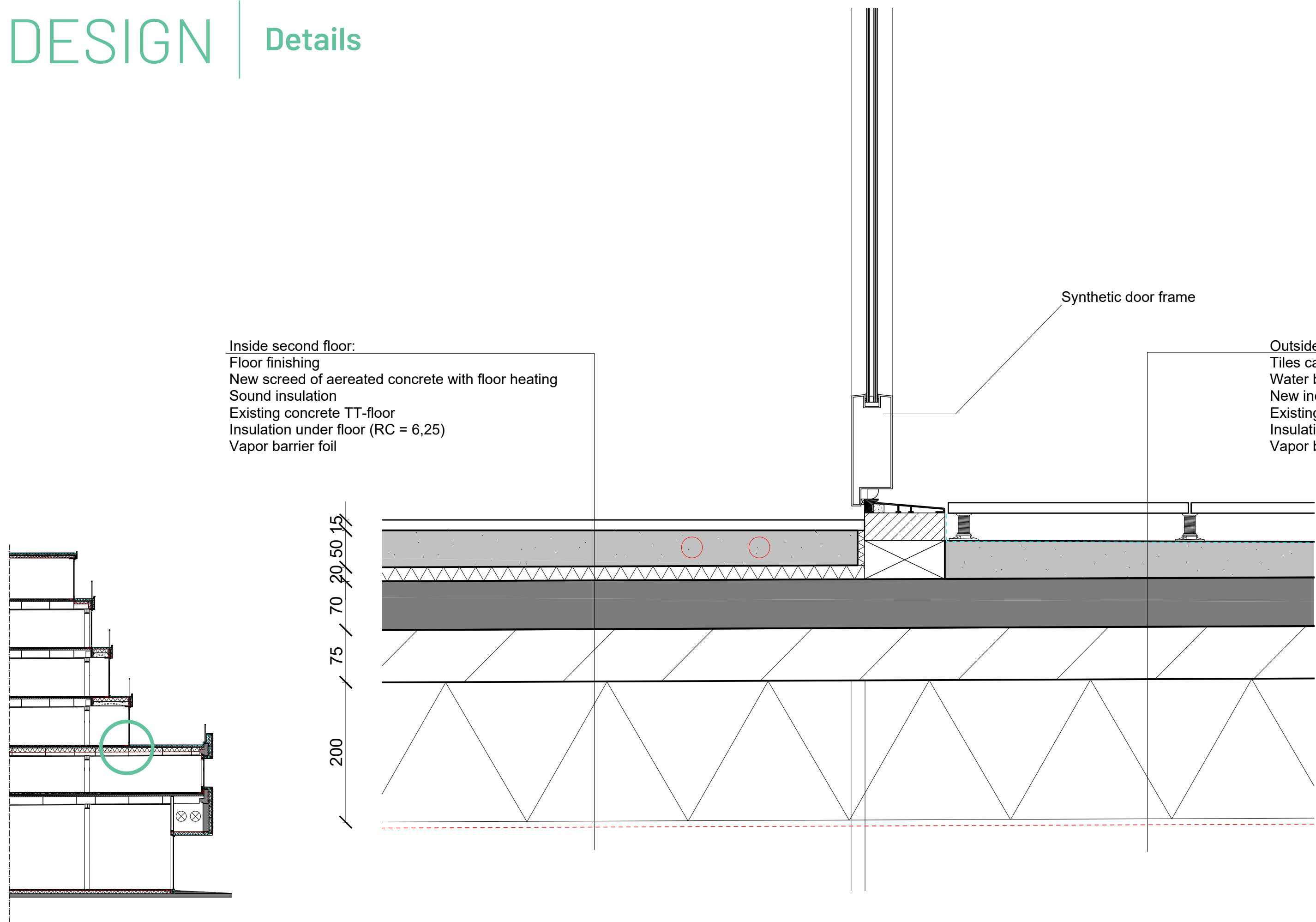

Inside second floor:
Floor finishing
New screed of aerated concrete with floor heating
Sound insulation
Existing concrete TT-floor
Insulation under floor (RC = 6,25)
Vapor barrier foil

Synthetic door frame

Outside second floor:
Tiles carried by columns
Water barrier foil
New inclined screed of aerated concrete
Existing concrete TT-floor
Insulation under floor (RC = 6,25)
Vapor barrier foil

Outdoor third floor:
Tiles carried by columns
Water barrier foil
Inclined aerated concrete screed
Wooden panel
Vapour barrier foil
Wooden construction frame with insulation (Rc = 6,25)
Wooden panel

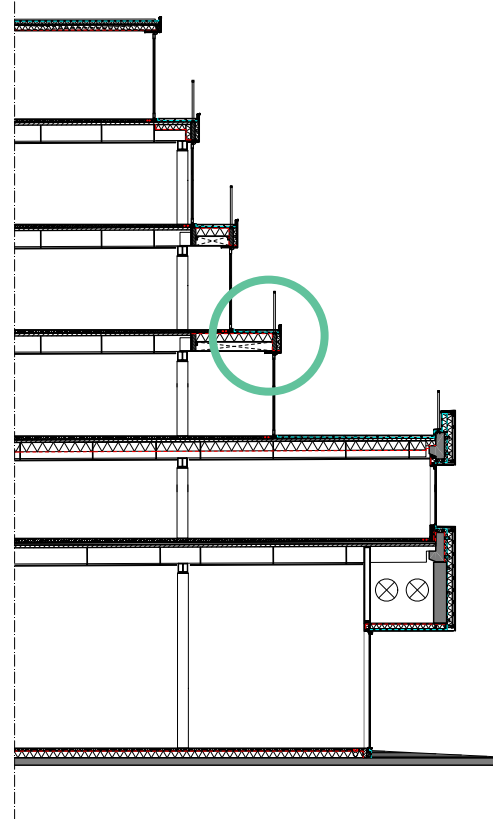

15 / 45 /
25 / 15 /
500
15 /

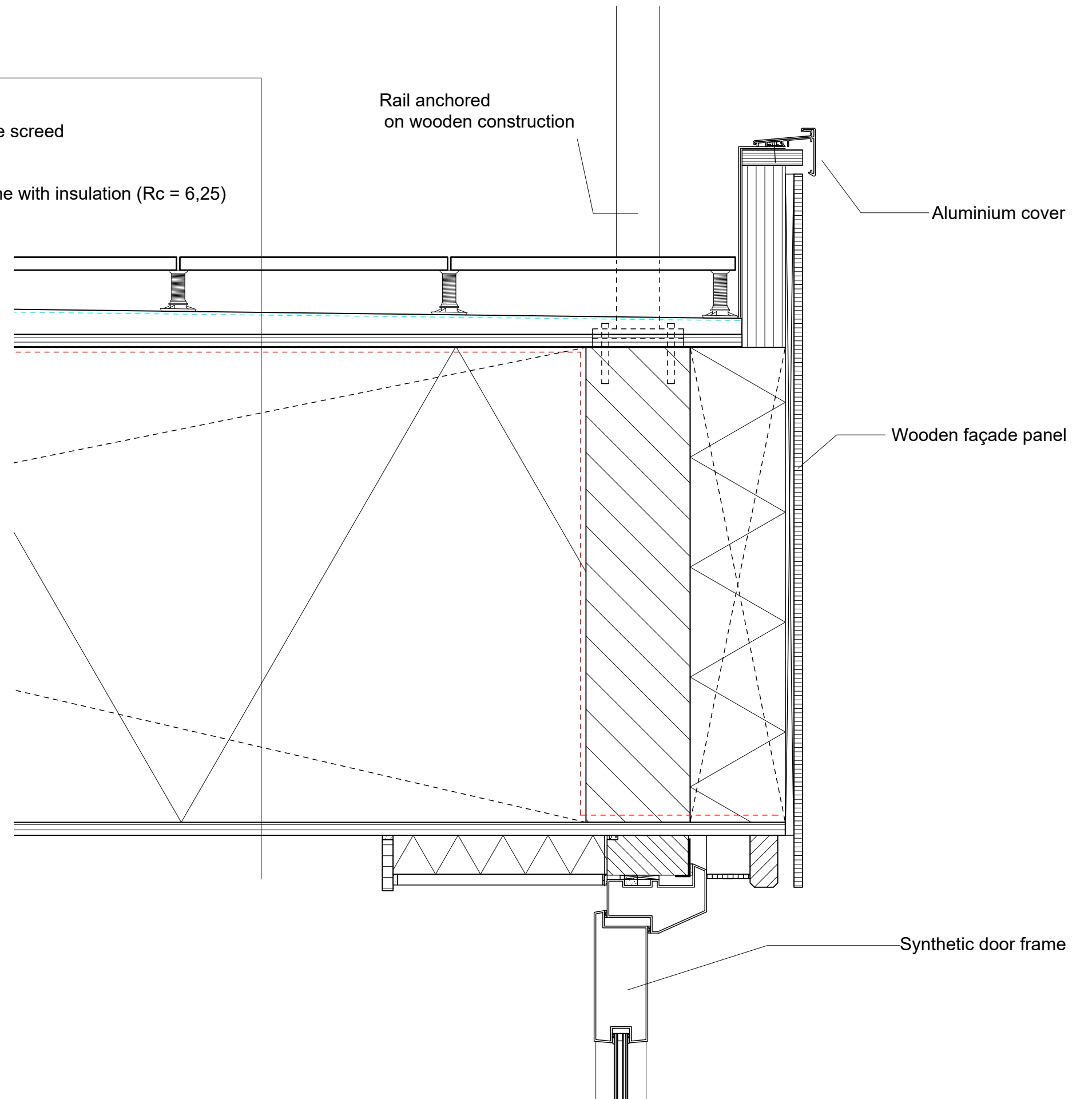

Inside second floor:
Floor finishing
New screed of aereated concrete with floor heating
Sound insulation
Existing concrete TT-floor
Insulation under floor (RC = 6,25)
Vapor barrier foil

Outdoor fifth floor:
Tiles carried by columns
Water barrier foil
Inclined aereated concrete screed
Existing TT-floor
Wooden construction frame with insulation (Rc = 6,25)
Vapour barrier foil
Wooden panel

75 20,50 15

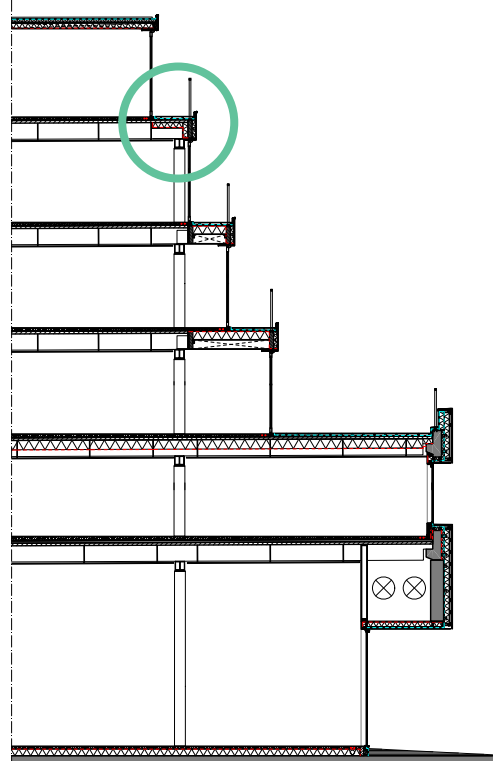
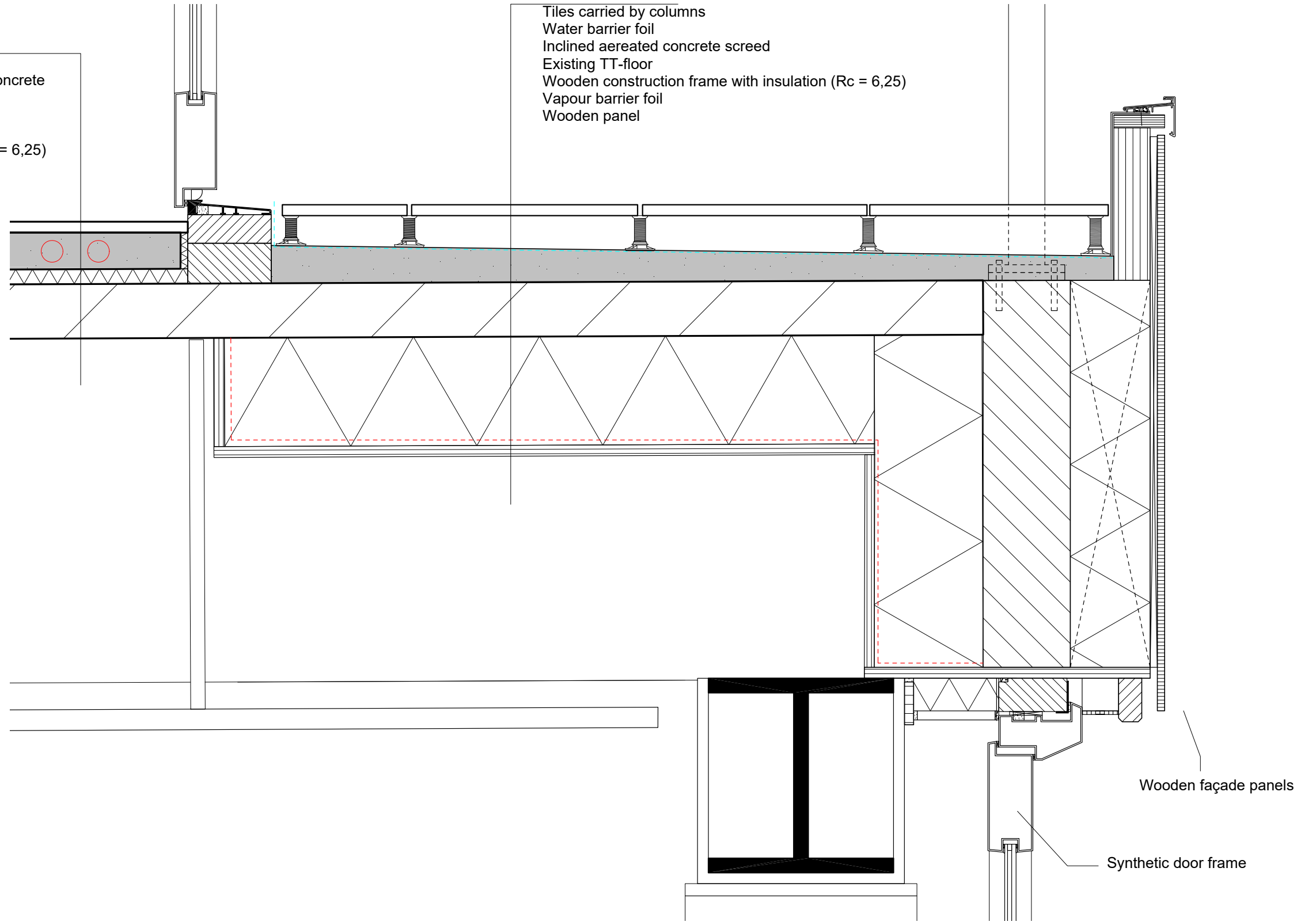

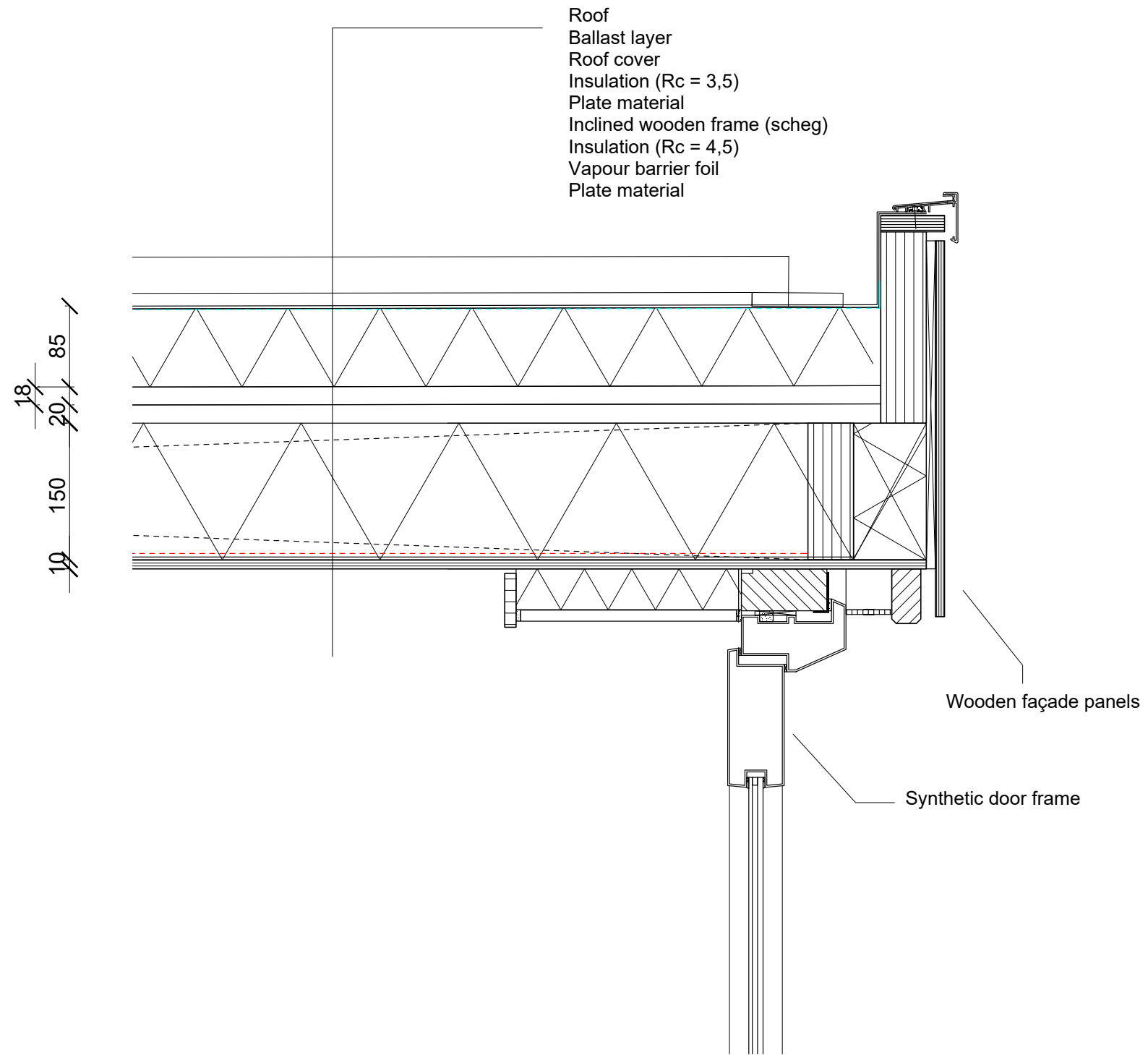
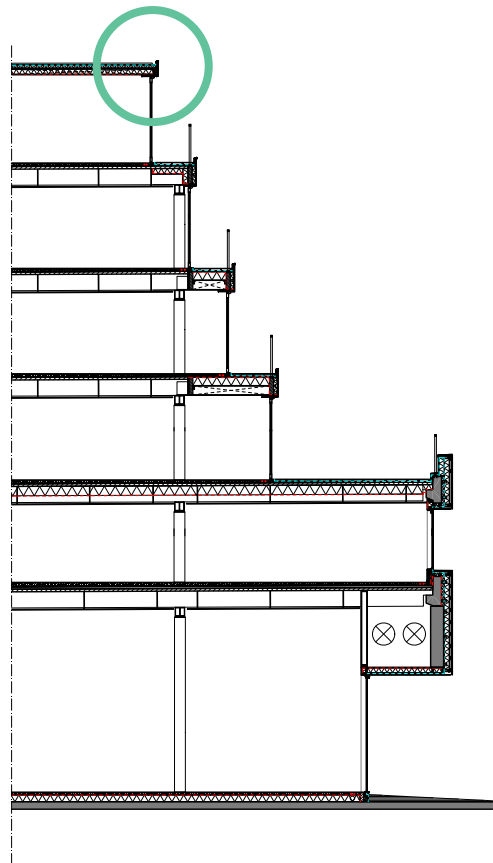

DESIGN

Façade fragment

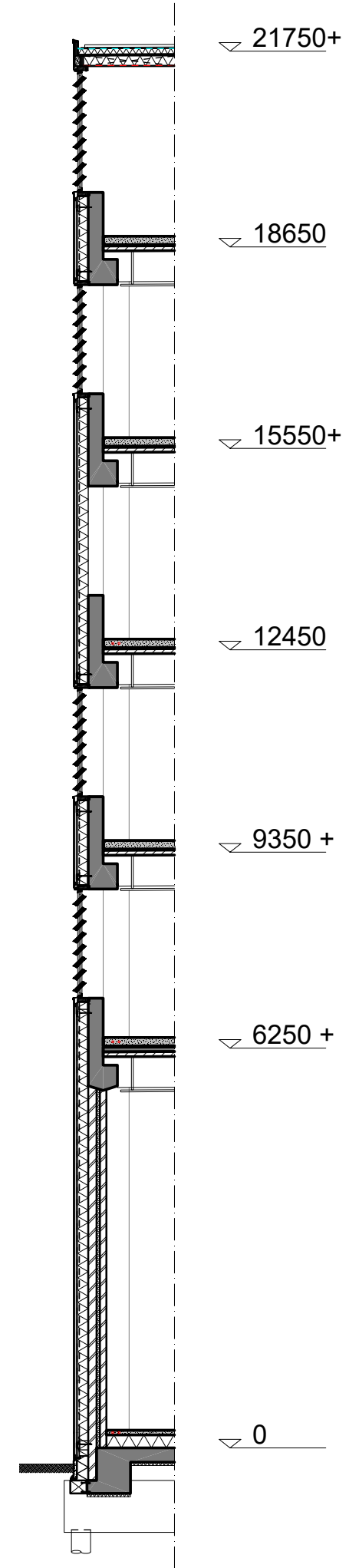
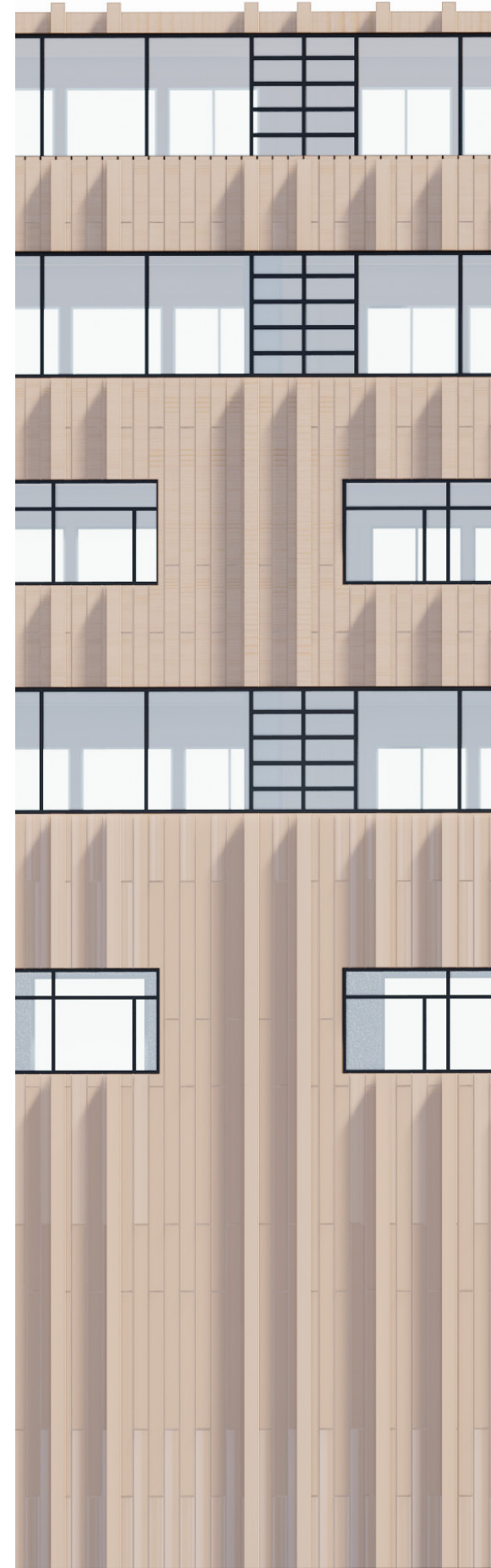
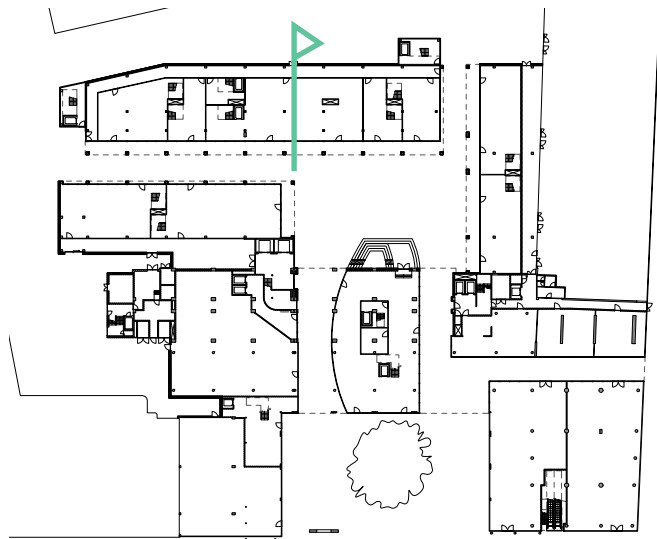

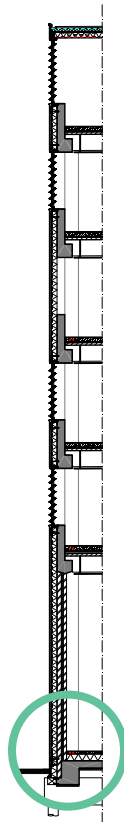
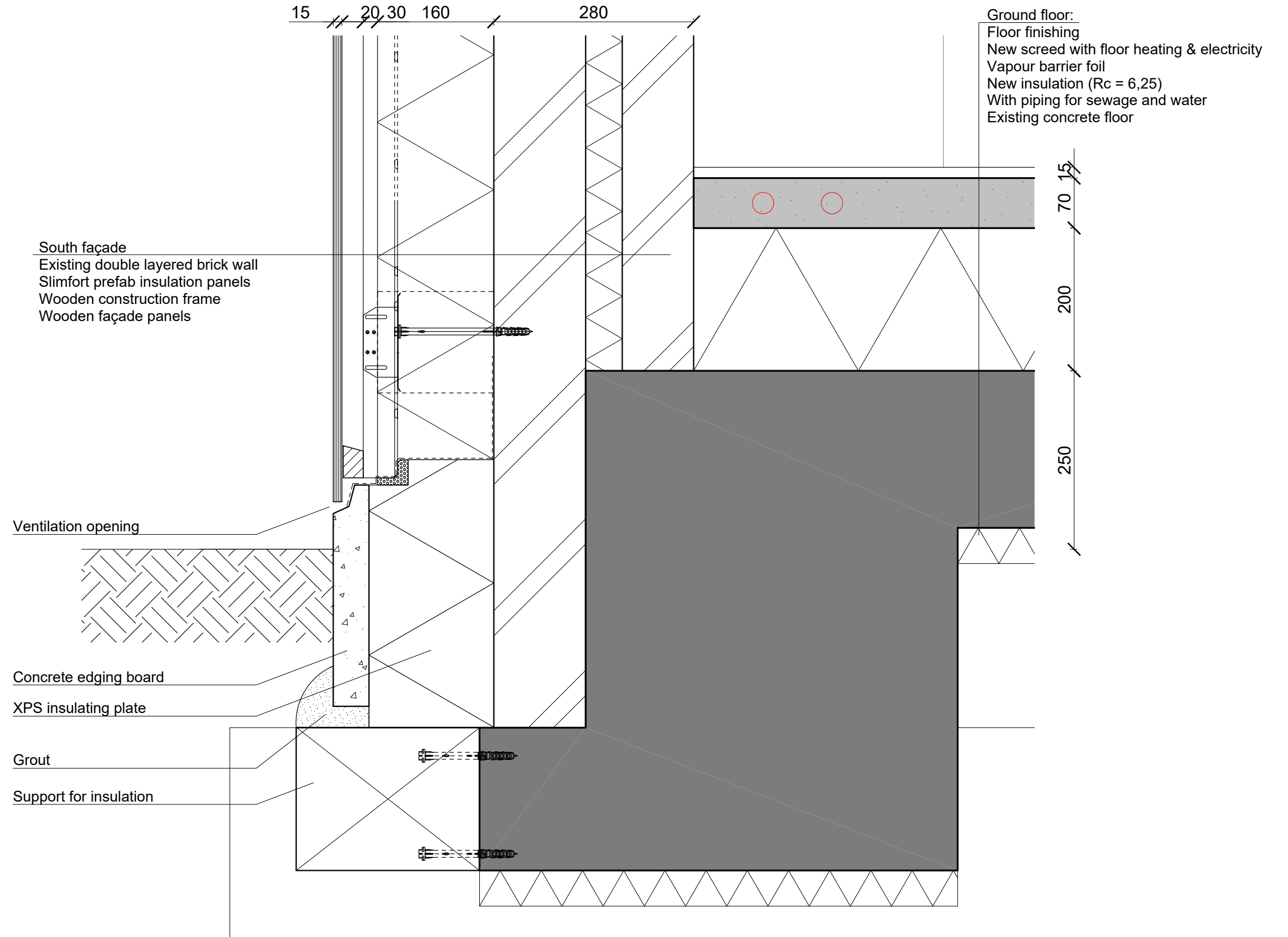

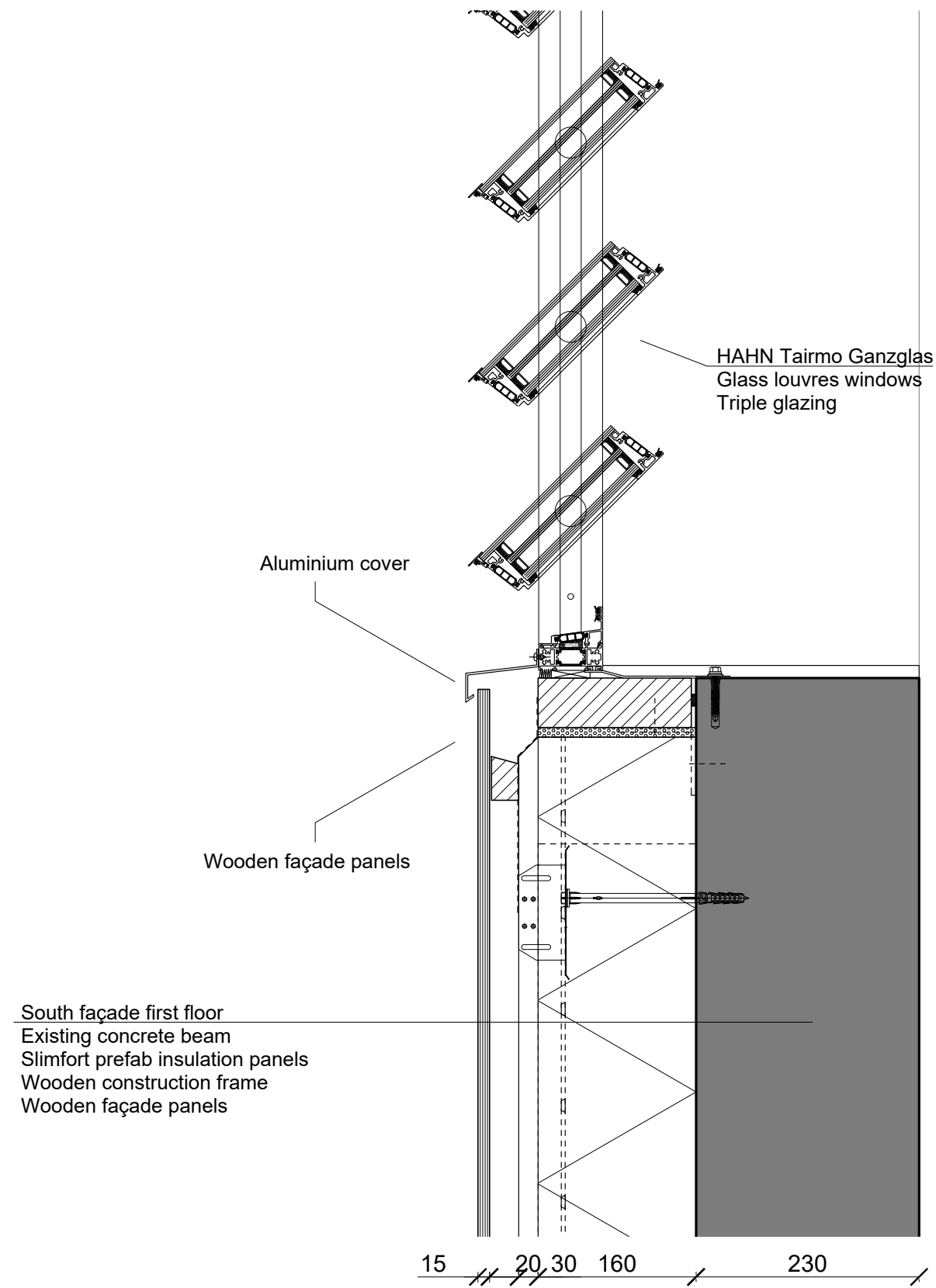
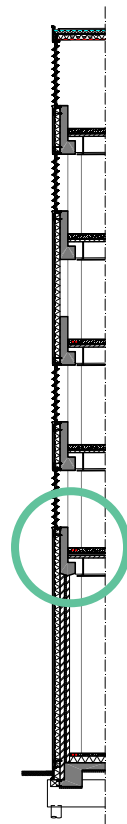

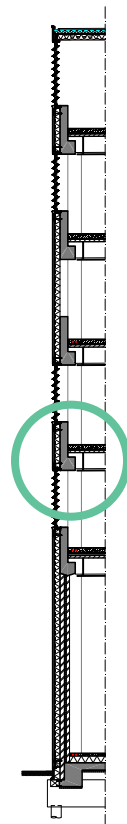

South façade first floor
Existing concrete beam
Slimfort prefab insulation panels
Wooden construction frame
Wooden façade panels

Aluminium cover

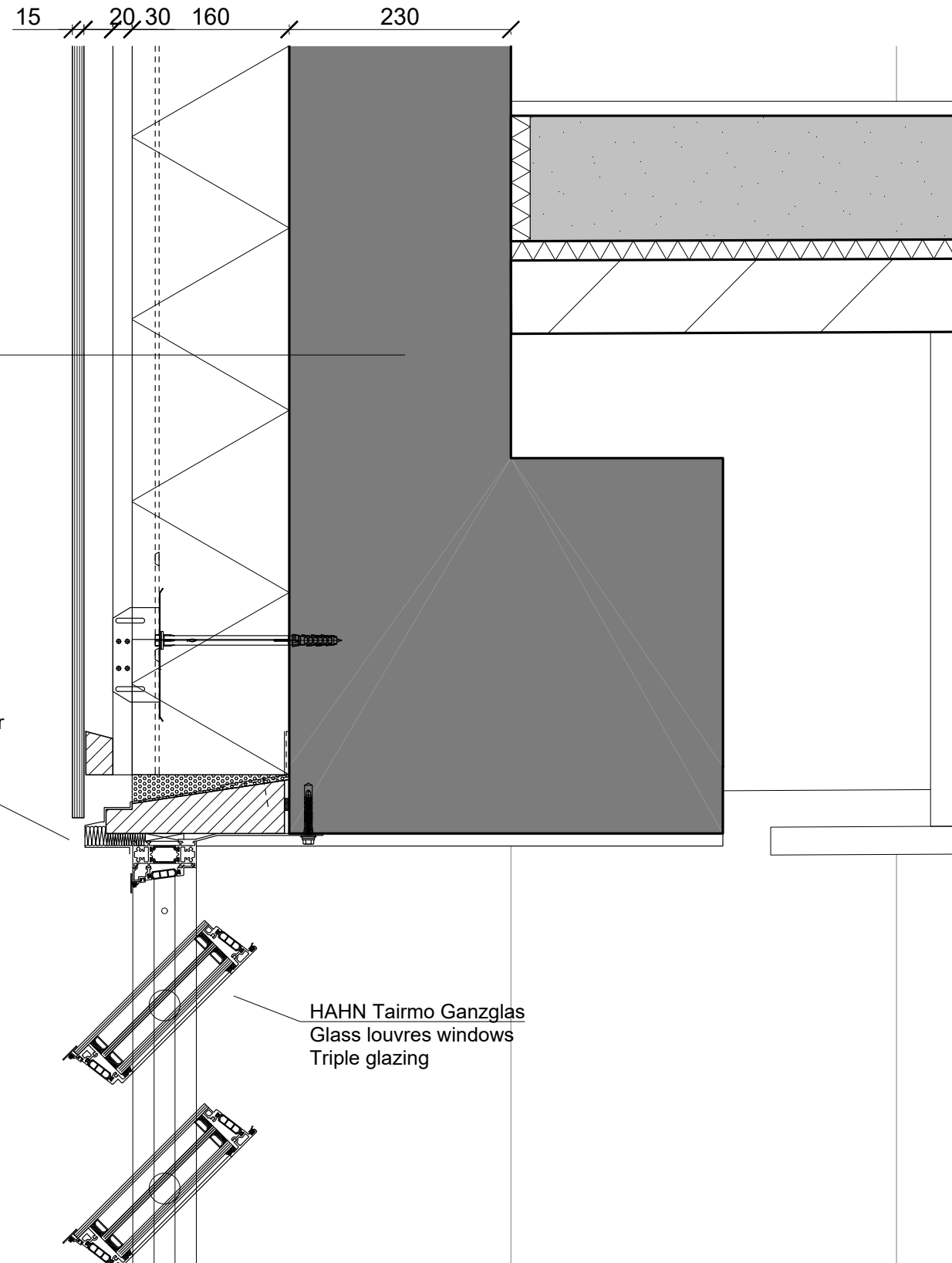

HAHN Tairmo Ganzglas
Glass louvres windows
Triple glazing

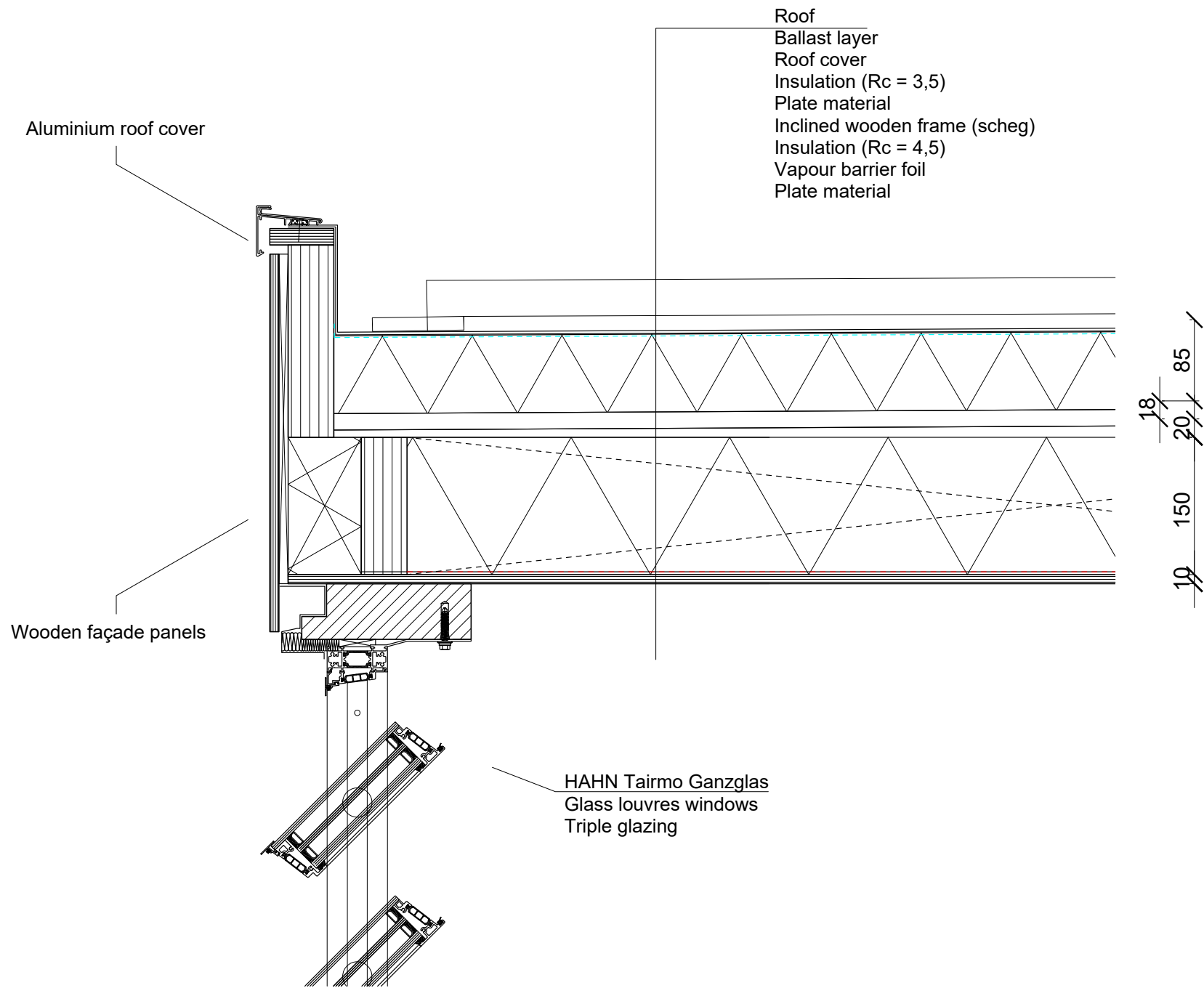
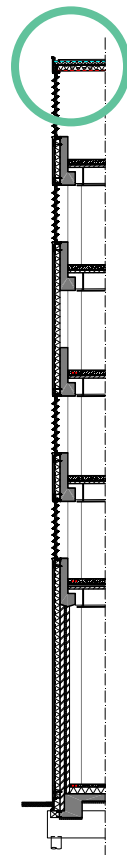

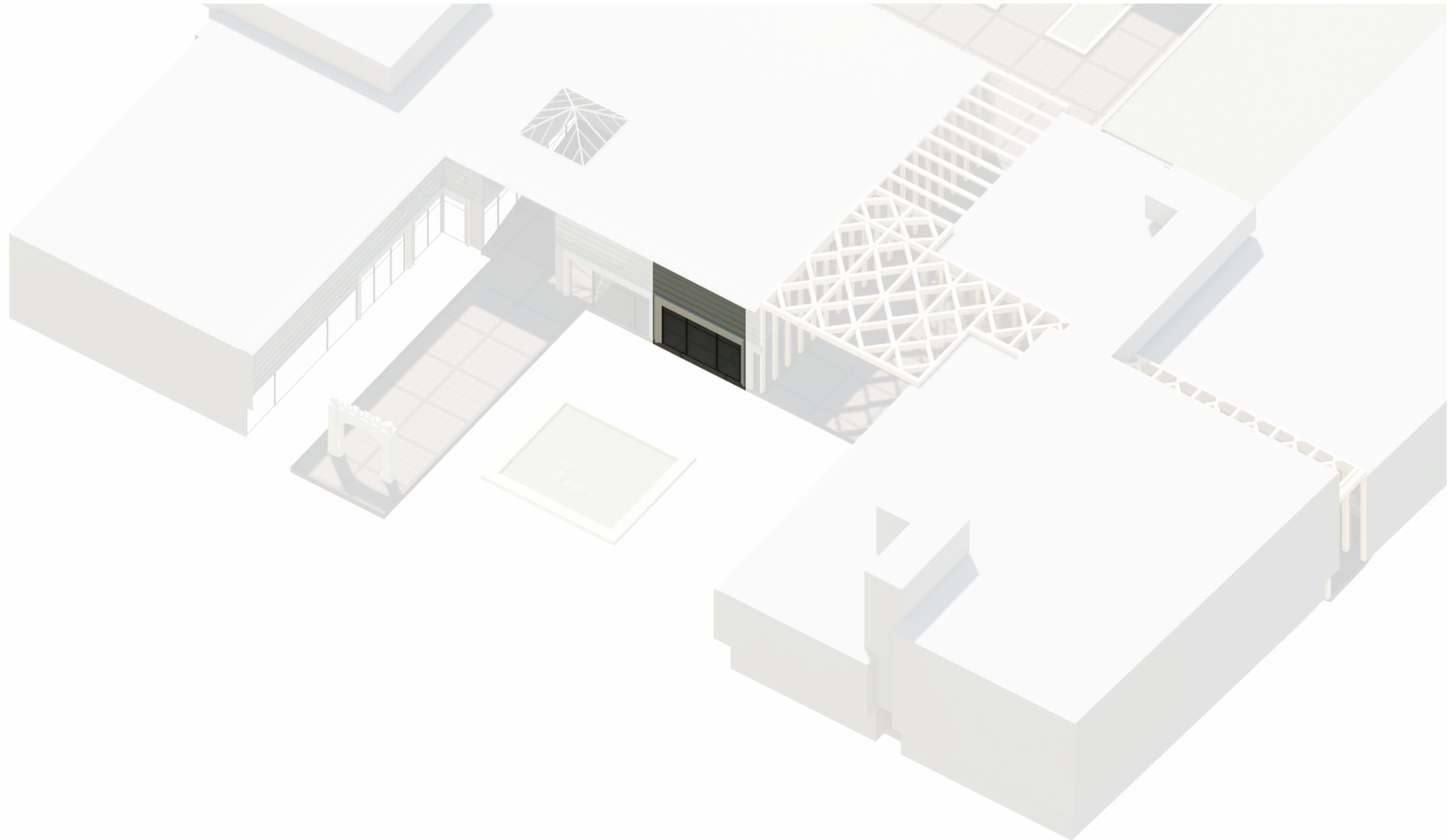

DESIGN

Façade fragment

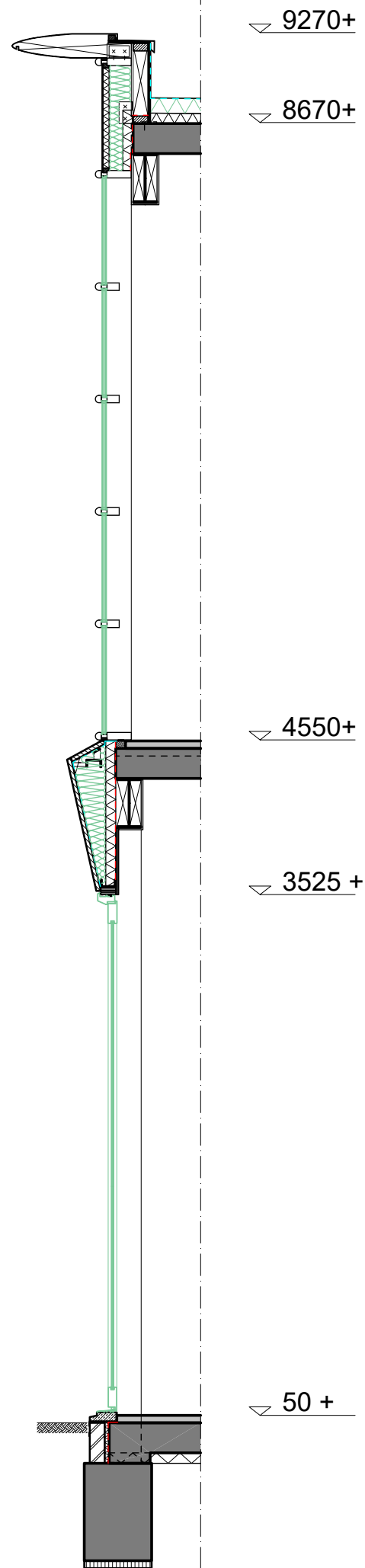
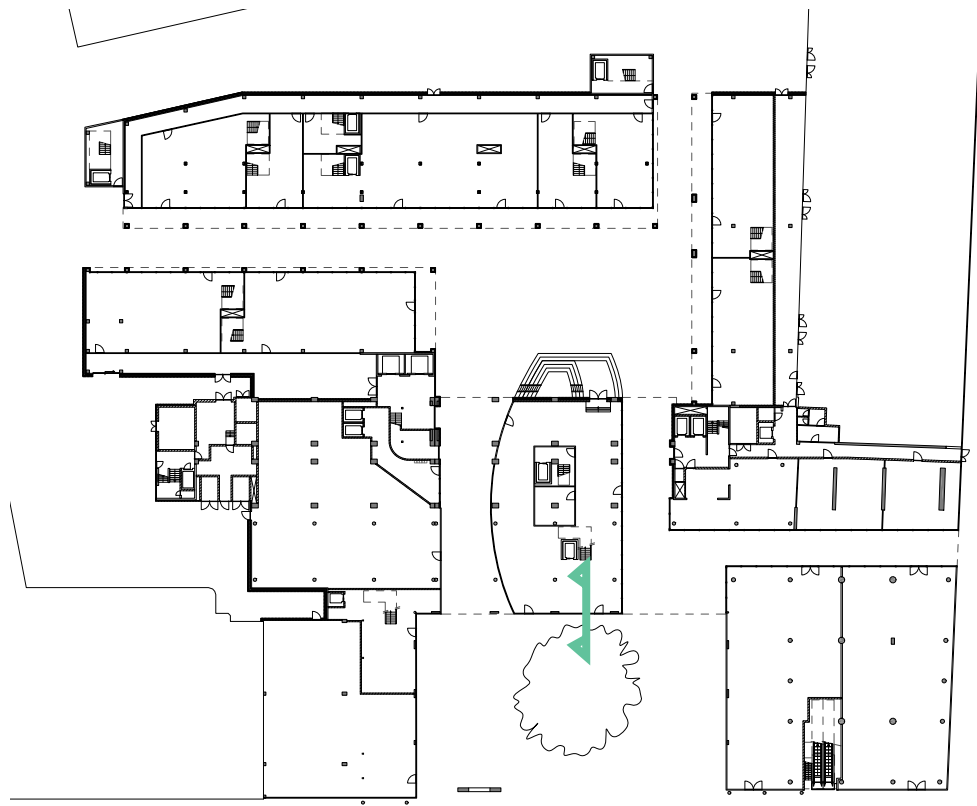

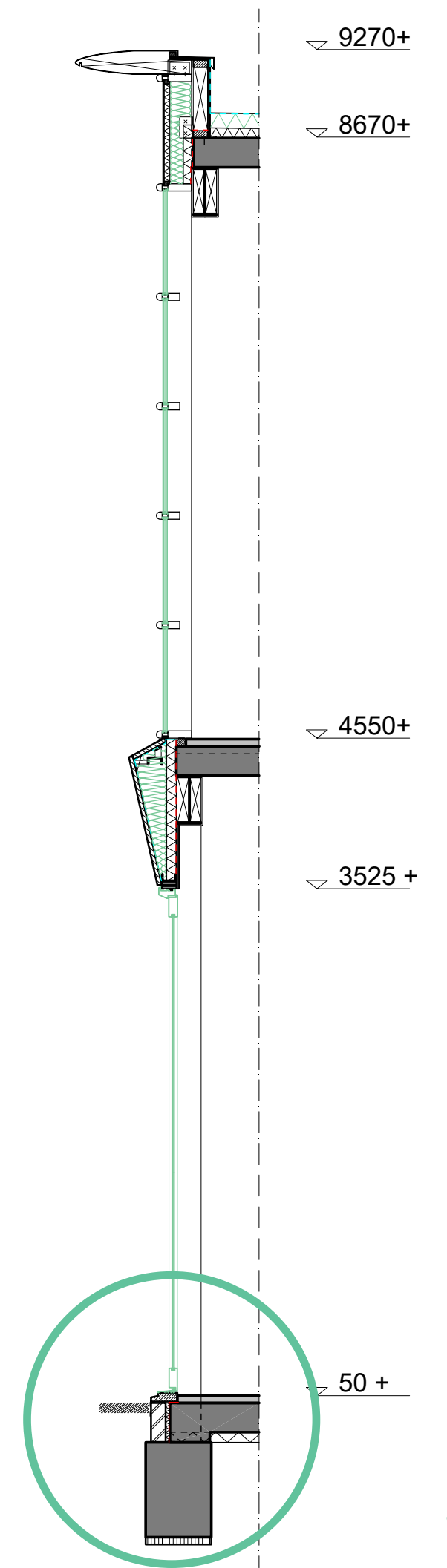
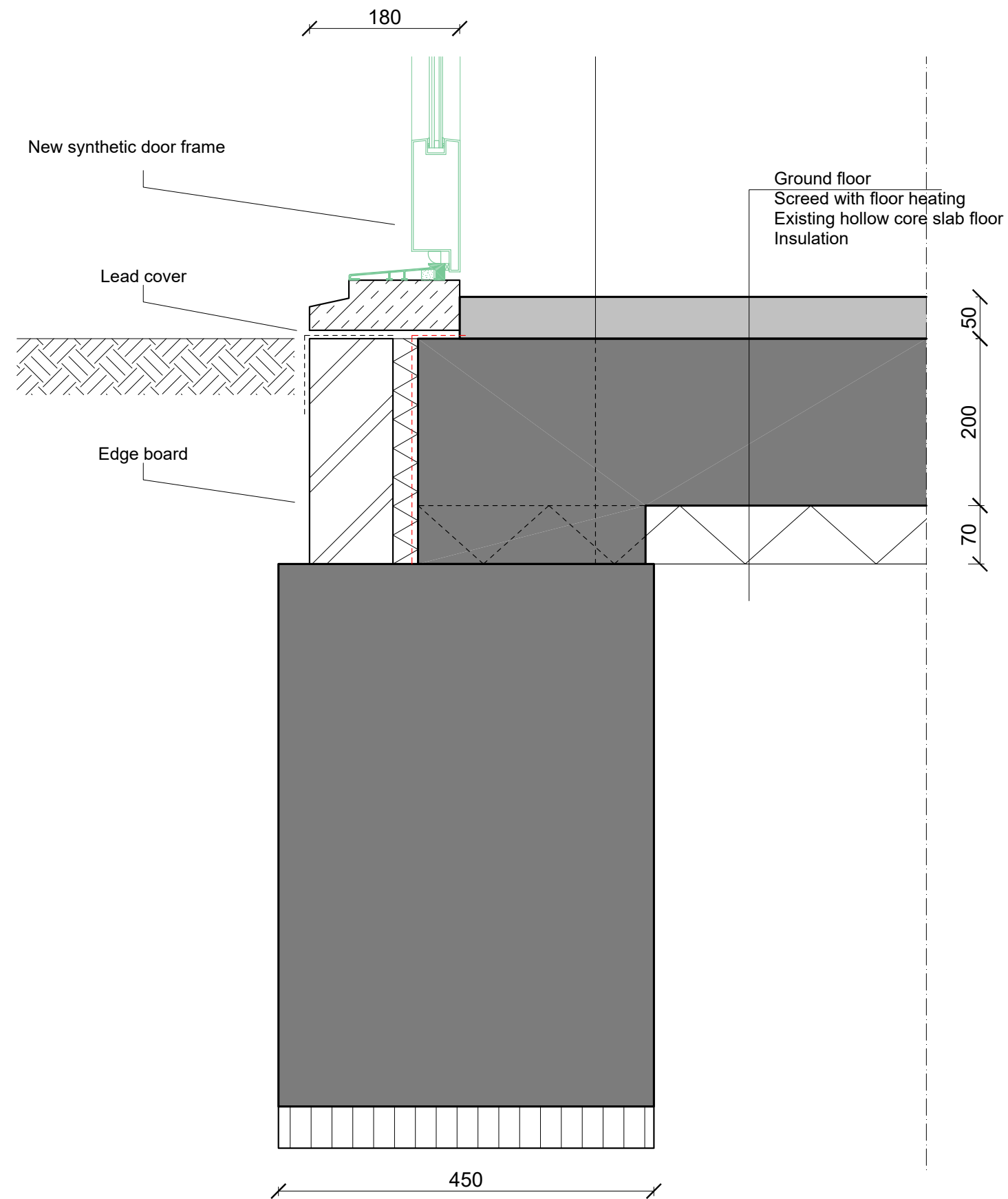

DESIGN

Façade fragment

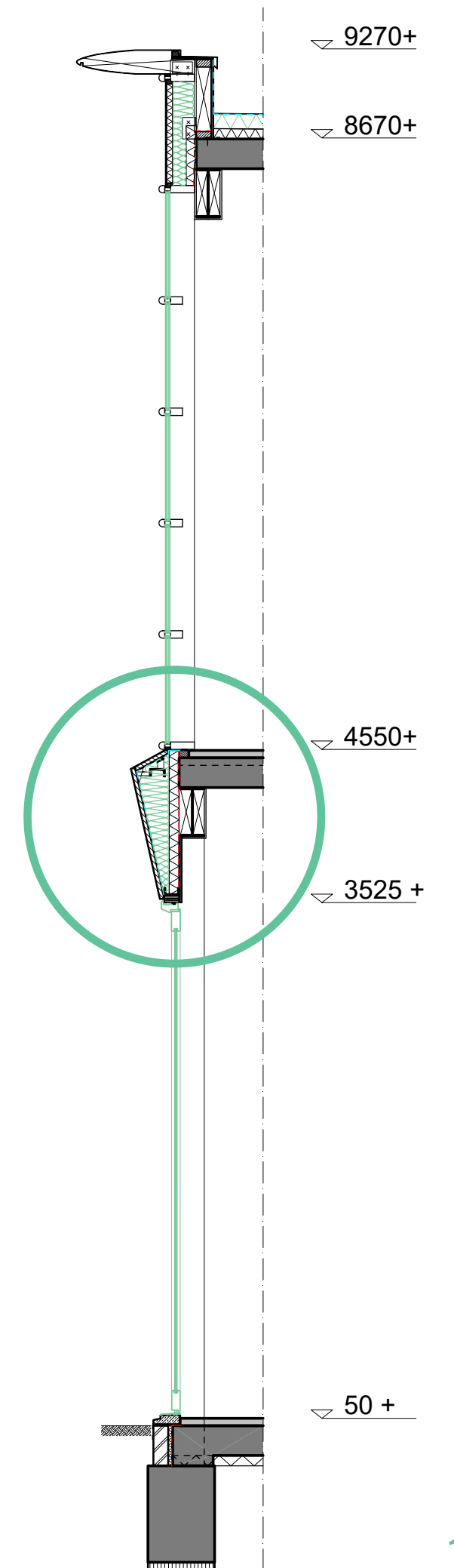
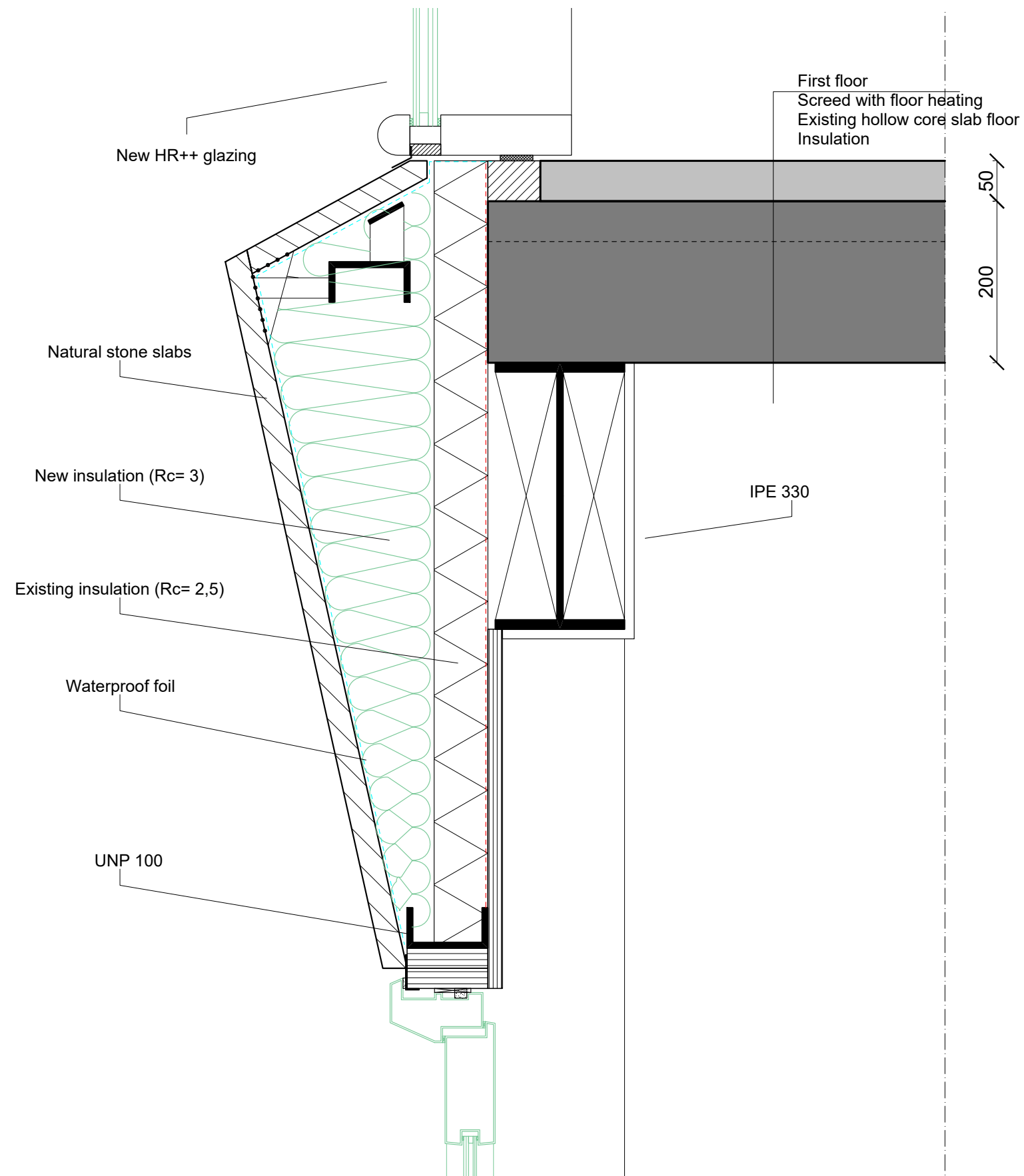

DESIGN

Façade fragment

