

EQUIPMENT FOR MEASURING SIX MOTIONS OF A SHIP MODEL

By Fukuzō TASAI, Masahiro KANAME
and Hiroyuki ARAKAWA

Summary We have made a equipment for measuring six motions of a ship model in waves. Making use of this equipment excellent results of coupled motions in short-crested waves are obtained.

In this paper a simple profile of this equipment is explained.

1. Introduction

A ship has six degrees of freedom in its motions. It is necessary for measuring six motions, for example, in oblique waves to make particular apparatus.

Now, we know equipments which have been used at N.S.M.B. [1] in Netherlands and at Stevens Institute [2] in U.S.A. for this object. Then, we have made the equipment to measure six motions of a ship model in oblique waves and short-crested waves.

This equipment is currently used at the experimental tank in our Institute.

2. Structure and measuring Methods

General arrangement of this equipment is shown in Fig(1). $O_1-\xi_1\eta_1\zeta_1$ is the coordinate fixed in space. $G_0 - xyz$ is the one fixed in model. G_0 is centre of gravity of a model. $G_0\xi$ and $O_1\xi_1$, $G_0\eta$ and $O_1\eta_1$, $G_0\zeta$ and $O_1\zeta_1$, run parallel each other.

As shown in Fig. 1, 2, 3 and 4, this equipment is consisted of three main parts, that is, two subcarriages, heaving rod and gimbal picking up angular displacement. Heaving rod is always held vertically and moves to up and down, and same time the yawing rod - the under part of heaving rod - can rotate freely in horizontal plane. Heaving displacement of the rod on ζ axis, surging displacement of surging subcarriage on ξ axis and swaying one of swaying subcarriage on η axis, are picked up by potentiometer p_1 , p_2 and p_3 using piano wire and pulley.

Next, rolling angle θ , yawing angle φ , pitching angle ψ , are defined the angular displacement around x , ζ and η . *$\rightarrow \eta'$ zie tabel in fig 1. (P6)*

Then, the block diagram of electronic circuit is shown in Fig(5). A distance of surging rail is 880 mm and its length is 4,000 mm.

The standard model length used on our experiments is usually 3 meters in Lpp. The total mass of subcarriages are one or three percents to the one of a model, therefore, the dynamic effect of subcarriage to the motion of a model is very little. Yawing transducer has two potentiometers and the one of its is

used for the autocontrol of a model running in waves.

A comparison between this equipment, the one of N.S.M.B. and Stevens Institute is shown in following table.

References

1. G. Vossers, W. A. Swaan, H. Rijken: "Experiments with Series 60 Model in Waves", S.N.A.M.E., 1960.
2. E. V. Lewis, E. Numata: "Ship Motions in oblique Seas", S.N.A.M.E., 1960.

(Received February 5, 1965)

Table

Measuring Elements and axis of coordinate		Measuring Methods						
		N.S.M.B.		Stevens institute		This Equipment		
<i>minutely fast stelsel</i> <i>Euler</i>	Surging	on ξ	Velocity	Pulse system	Velocity	Servo Mechanism	Displacement	Potentiometer
	Swaying	on η	Displacement	Synchro	Displacement	Potentiometer	"	"
	Heaving	on ζ	"	Potentiometer	"	"	"	"
	Rolling	around X	"	"	"	Rotary differential transformer	"	"
	Pitching	around η'	"	"	"	Potentiometer	"	"
	Yawing	around ζ'	"	Synchro	"	"	"	"
Ship Model		Self propelled Lpp=10'		Self propelled Lpp=5'		Self propelled Lpp=3m		
Control		Manual steering or autocontrol on towing carriage		Autocontrol		Manual steering or autocontrol on towing carriage		
Surging Subcarriage				$\pm 2.5'$ *		± 170 cm *		
Swaying Subcarriage		none		$\pm 1.5'$ *		± 35 cm *		
Weight of Subcarriage		2kg		4 lbs		3.4 kg		

* Range of activity of a Ship Model

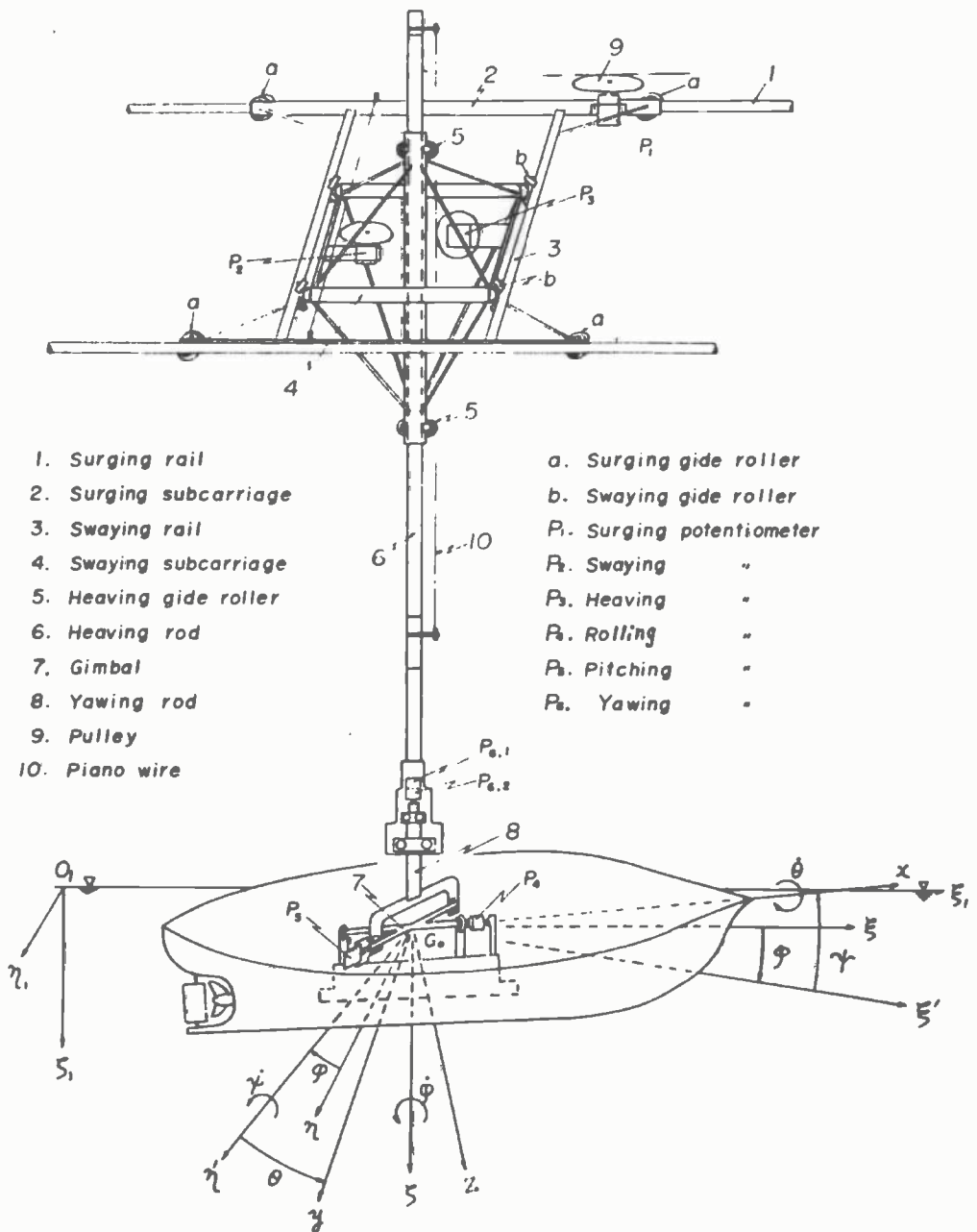

Fig. 1

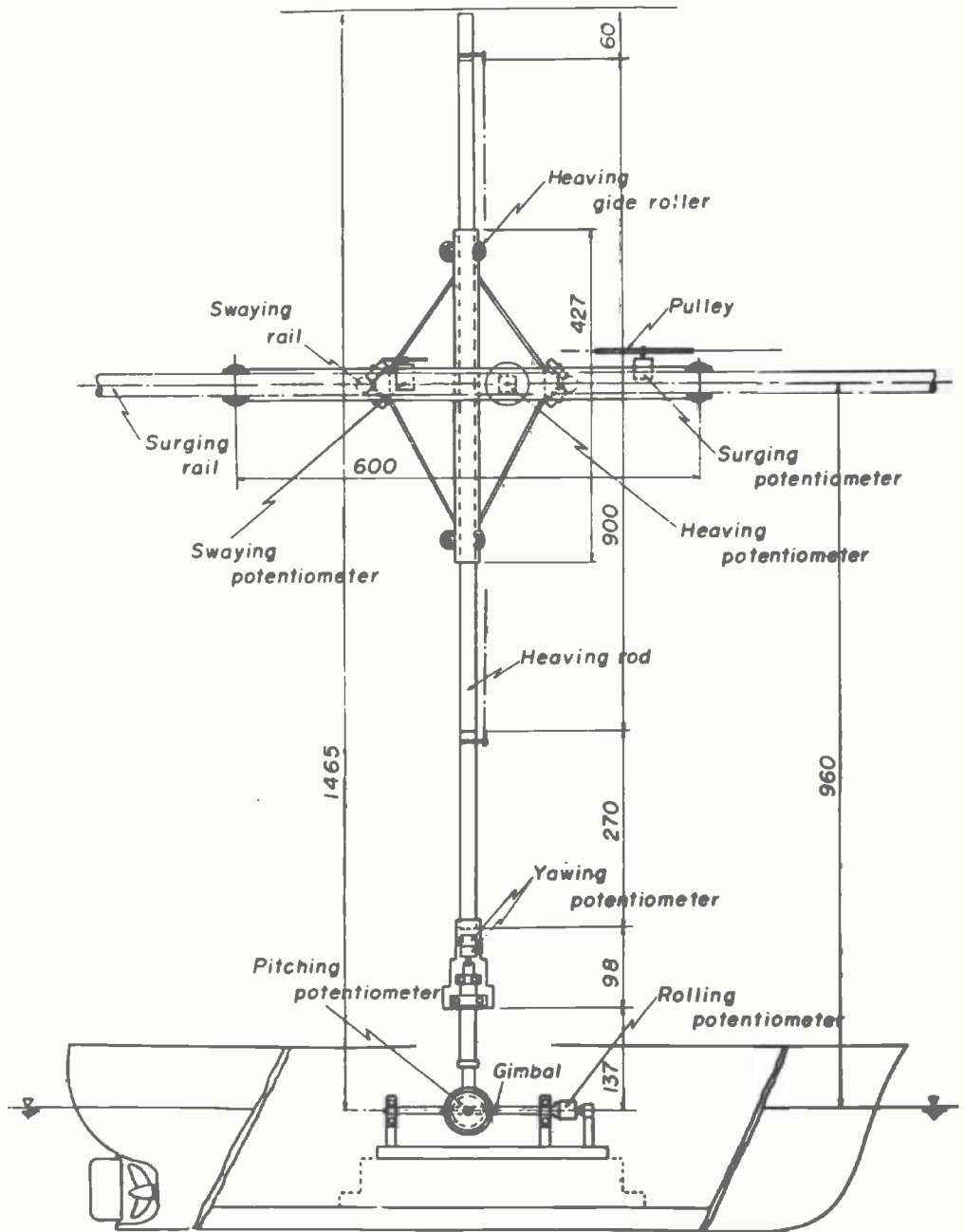

Fig. 2

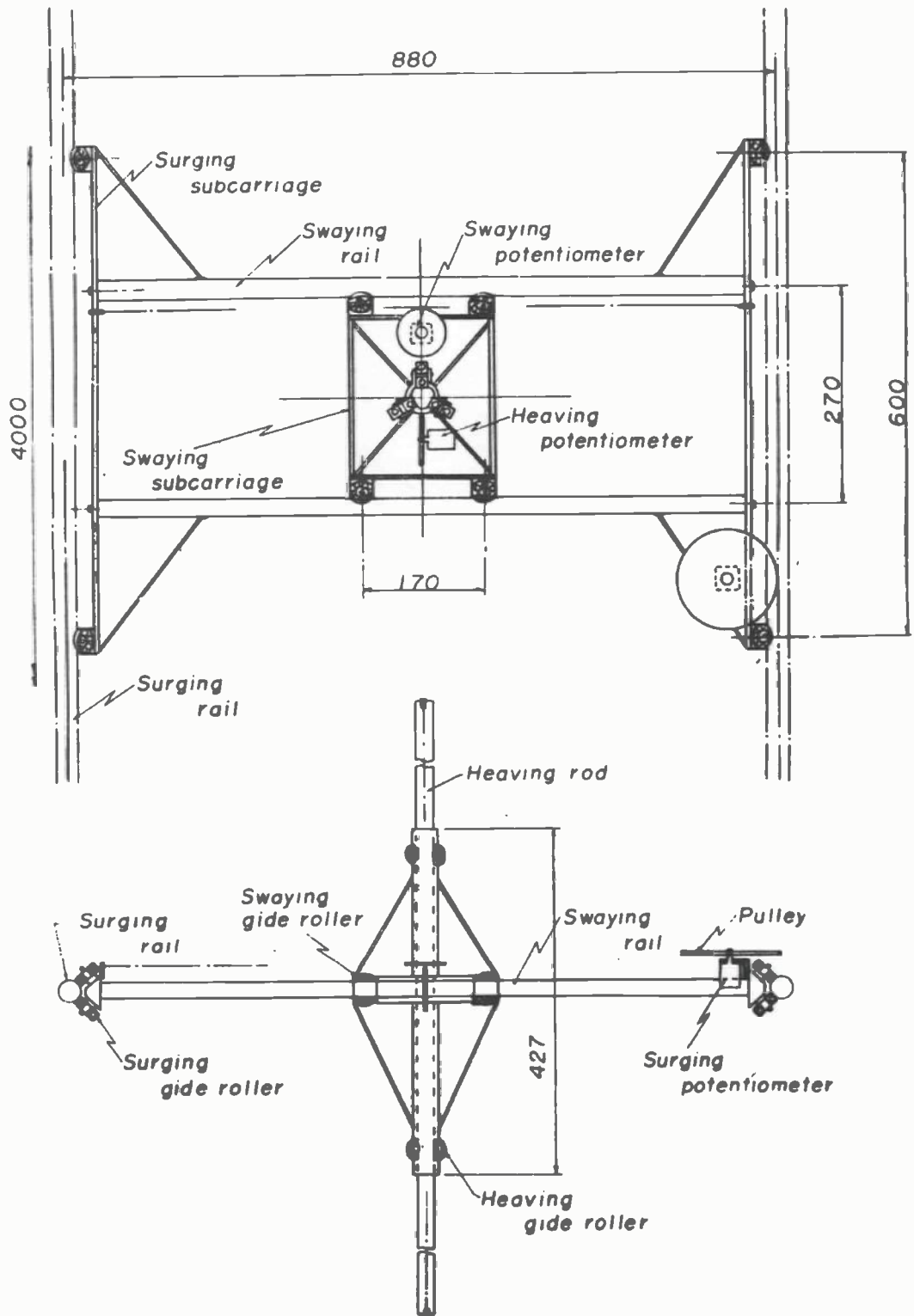

Fig. 3

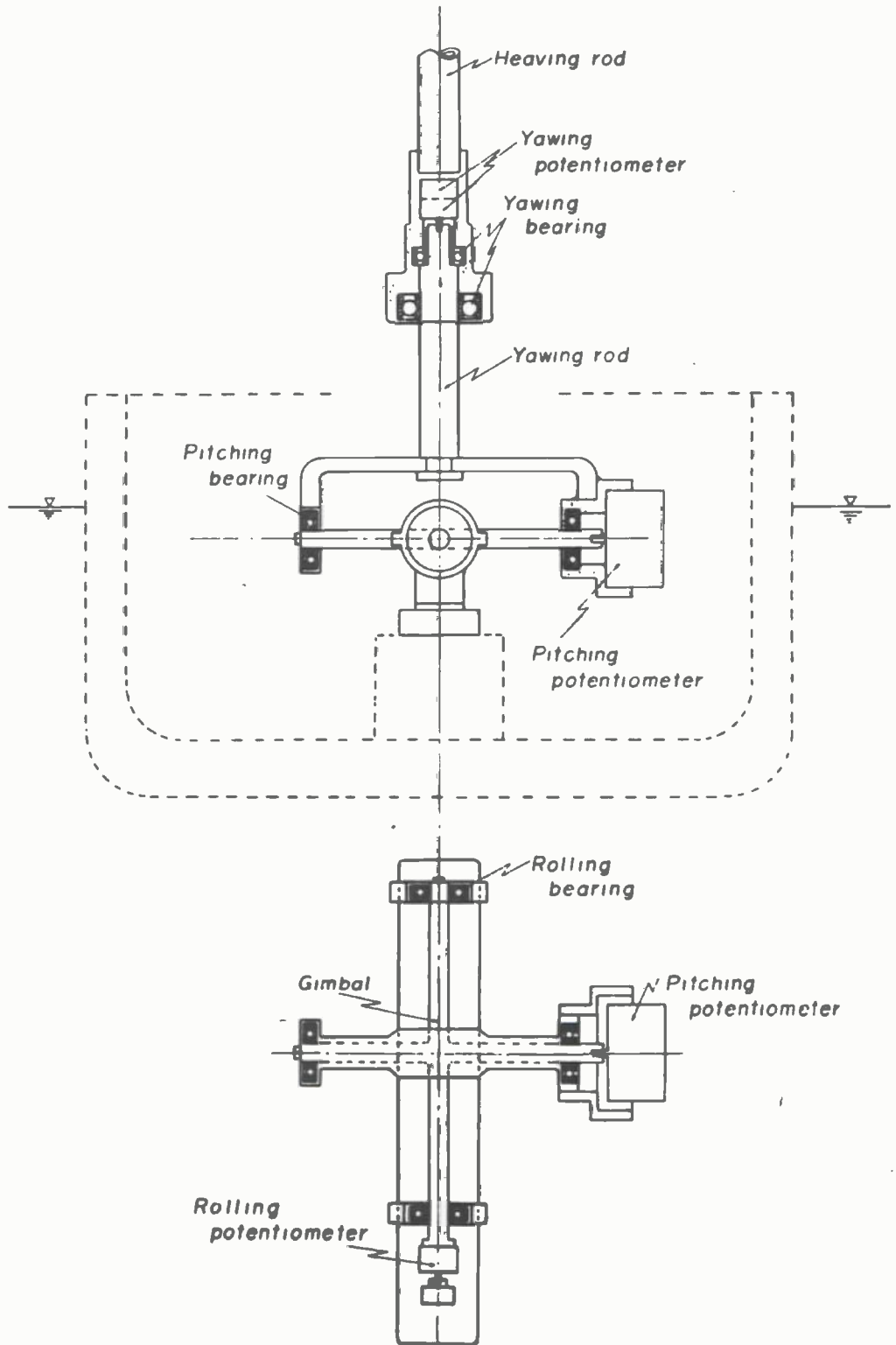

Fig. 4

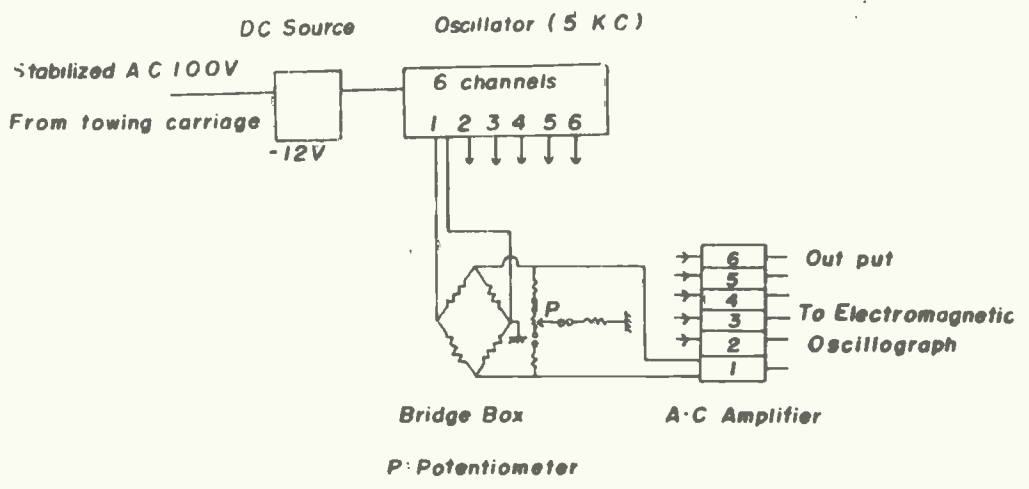

Fig. 5