

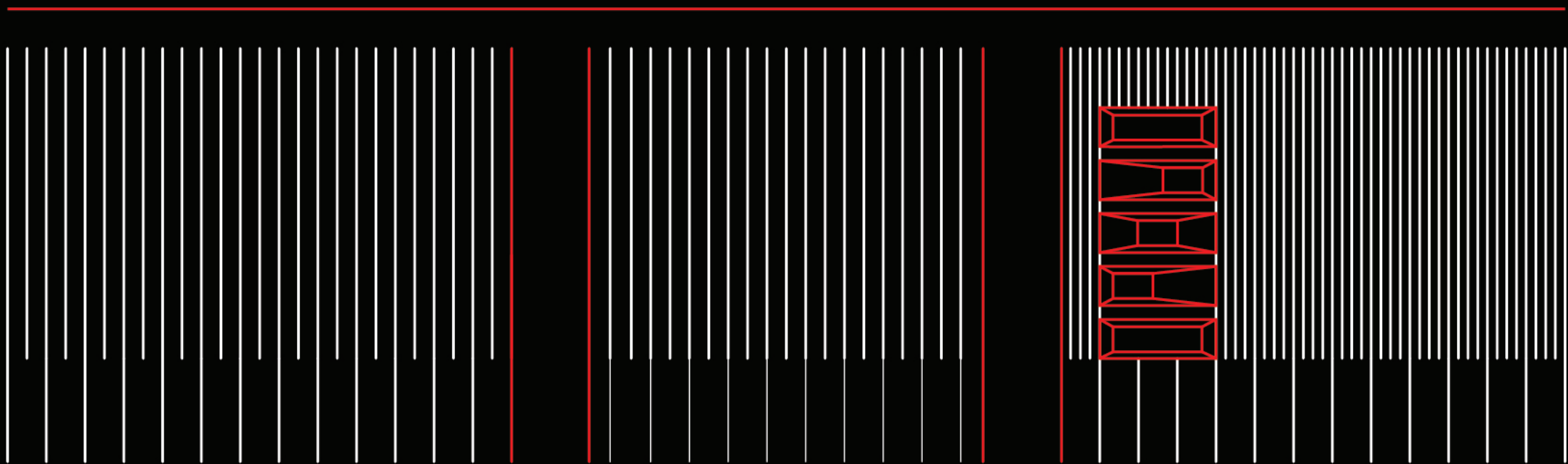

THRESHOLDS OF POWER

IMAN RAMSHINI
COMPLEX STUDIO
MARCH 2026



CONTENT

INTRODUCTION

THEORY
RESEARCH
CONCEPT
DESIGN BRIEF
DESIGN
TECHNICAL
CONCLUSION

MILAN



1:150000

COURTHOUSE OF MILAN

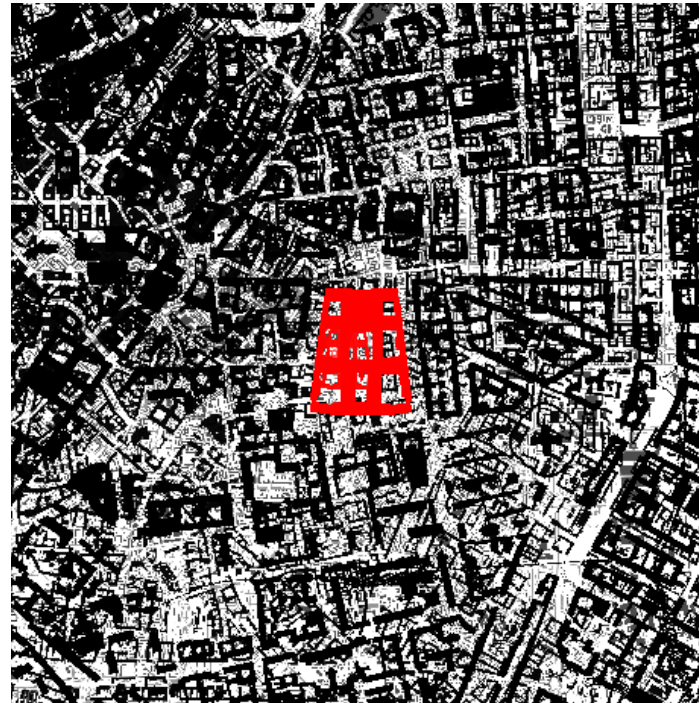

SCALE OF COURTROOMS

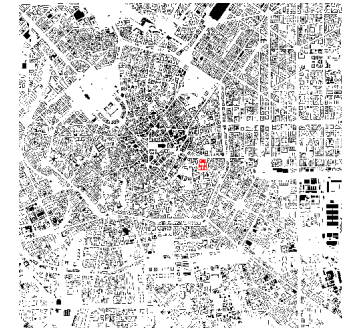

SCALE OF MILAN

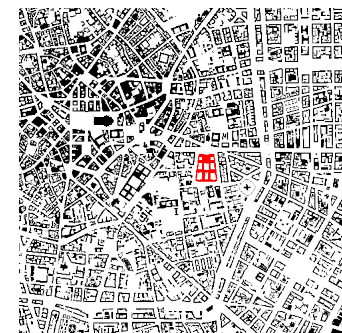

SCALE OF COURTHOUSE

3X SCALES

CIVICNESS



PORTICO

CONTENT

INTRODUCTION

THEORY

RESEARCH

CONCEPT

DESIGN BRIEF

DESIGN

TECHNICAL

CONCLUSION



POWER



POWER TO



THRESHOLDS OF POWER



POWER OVER

THRESHOLDS OF POWER OVER/TO

POWER TO



THRES OF POWER

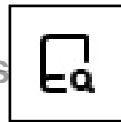

READING



POWER OVER

POWER OVER\TO OF THRESHOLDS

THRESHOLDS OF POWER OVER/TO

POWER TO

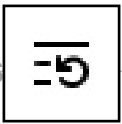
THRES  OF POWER
RECONFIGURING

POWER OVER
POWER OVER/TO OF THRESHOLDS

THRESHOLDS OF POWER OVER/TO

POWER TO



THRES OF POWER

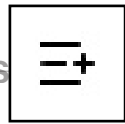

CREATING

POWER OVER/TO OF THRESHOLDS



POWER OVER

How do spatial thresholds in architecture—as dynamic, negotiation-based constructs—mediate and manifest power structures, and through what material-discursive interactions do they acquire meaning to socio-political hierarchies?

THRESHOLDS MATRIX

CATEGORY	ELEMENT	TYPE OF THRESHOLD	WHAT IT SEPARATES / CONNECTS	EFFECT ON PEOPLE
CITY	CITY GATES (MILAN) PIAZZA STREETS ARCADES	Historical threshold Collective threshold Flow threshold Urban threshold	Outside city / Inside city Individual / Public One place / Another Interior / Exterior	Marks entry and identity Creates visibility Directs movement Blends public and controlled space
ENTRY	GATES (COURTHOUSE) PORTICO / ARCADE SECURITY CHECK	Hard threshold Soft threshold Controlled threshold	City / Institution Outside / Inside (blurred) Public / Authorized	Selects access Slows and exposes Verifies bodies
MOVEMENT	HALLWAYS STAIRS / ELEVATORS	Directional threshold Hierarchical threshold	One space / Another Levels / roles	Guides movement Separates users
BOUNDARIES	WALLS BARRIERS / RAILINGS DOORS	Closed threshold Semi-open threshold Momentary threshold	Inside / Outside Free / Restricted One condition / Another	Blocks access Channels movement Creates pause
SURVEILLANCE	CAMERAS GUARDS	Invisible threshold Human threshold	Seen / Unseen Allowed / Stopped	Produces self-awareness Enforces control
REPRESENTATION	ARTWORKS TEXT / SIGNS	Symbolic threshold Informational threshold	Power / Public meaning Unknown / Rules	Shapes perception Directs behavior
FURNITURE	BENCHES COUNTERS / DESKS QUEUE BARRIERS	Temporal threshold Transactional threshold Micro-threshold	Movement / Waiting Individual / System Disorder / Order	Produces delay Processes identity Organizes bodies
JUDICIAL SYSTEM	COURTROOMS JUDGES / STAFF PROCEDURES CUSTODY CENTRE (HOLDING CELLS)	Final threshold Authority threshold Time threshold Confinement threshold	Before / Judgment Power / Subject Before / After Free / Detained	Produces verdict Applies law Structures process Contains the body

CONTENT

INTRODUCTION
THEORY
RESEARCH
CONCEPT
DESIGN BRIEF
DESIGN
TECHNICAL
CONCLUSION

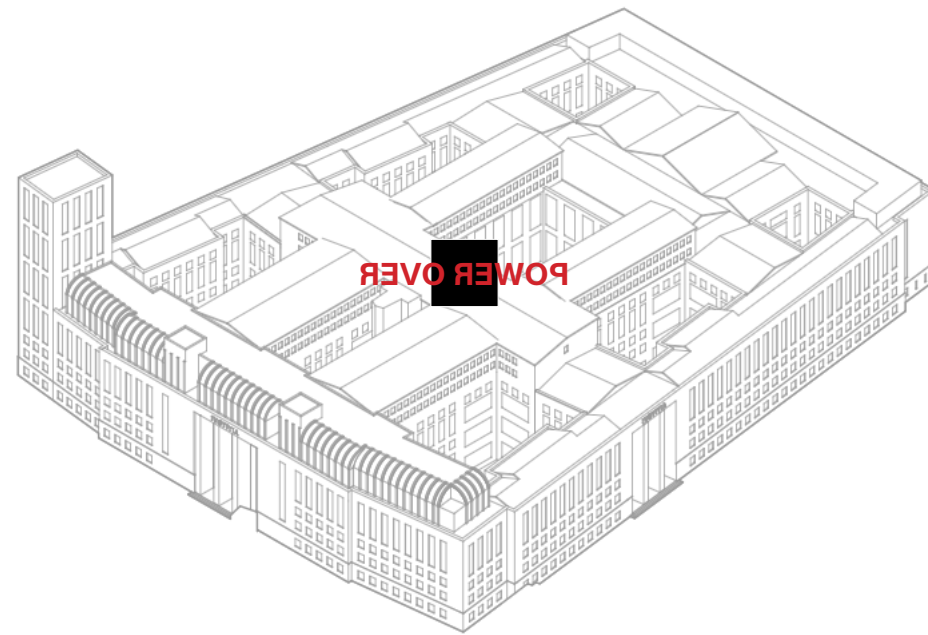

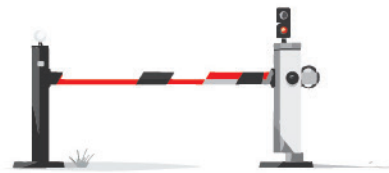

VISIBLE CONTROL

HARD BOUNDARIES \neq REAL SAFETY

POWER NEWS

"I WANTED REVENGE"; SHOOTING SUSPECT TELLS POLICE AFTER THREE KILLED IN MILAN COURTHOUSE



Giardiello's former lawyer Valerio Maraniello told the state broadcaster Rai that the case concerned a failed property business and that Giardiello was "very unusual" and "over the top" in his legal dealings.

Liberati said that CCTV footage had shown him entering the court and apparently showing "something, obviously an ID card". The entrance used by Giardiello, he explained, did not have a metal detector as it was "an entrance reserved for staff, magistrates and lawyers only".

Renzi criticised the security breach that had apparently enabled the suspect to enter the court with a gun. "The security systems of our country depend on women and men who are capable of heroism, but oversight cannot be

allowed to have holes and breaches such as those which there were at the court in Milan," he said.

"It must be established who messed up, how and why. Something did not work," Ansa quoted him as saying.

Regional authorities were shocked that anyone had managed to get into the court building with a weapon. "It's disturbing that just anyone can get into the Palace of Justice armed," said the right-wing president of the Lombardy region, Roberto Maroni.

"The fact that we're not talking about an organisation which surveyed the place first makes it even more perturbing," he said.

9 April 2015

ADDITIONAL 100 NEW ELECTRONIC EYES

This is the first initiative by Chief Prosecutor Roberto Alfonso on the issue of security raised in the aftermath of the massacre. The budget that made the camera plan possible is around one million and will be followed, by 2020, by turnstiles at the entrances and video intercoms

in front of the rooms of each magistrate. Will this completely eliminate the risk of blood flowing again in the Milanese house of justice?

16 Juli 2018

POWER IN MILAN

ITALIAN POWER DYNAMIC

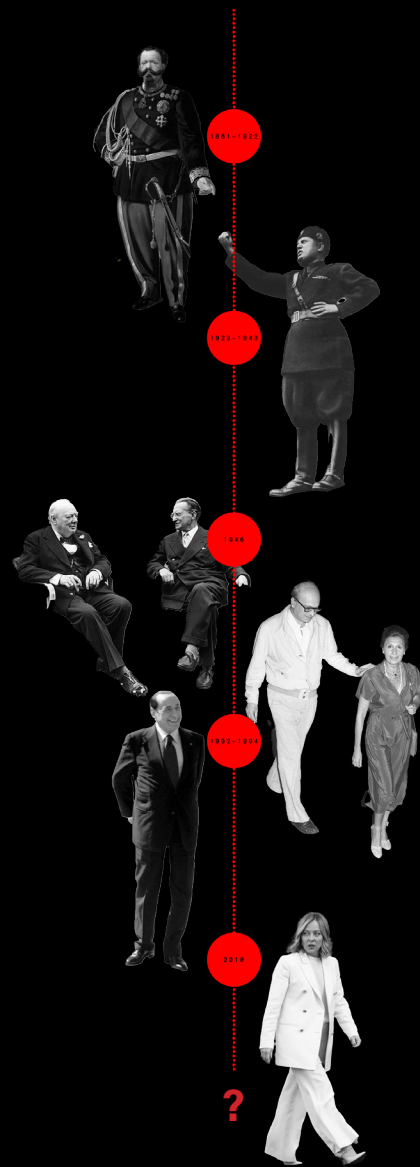

ITALIAN COURT STRUCTURE

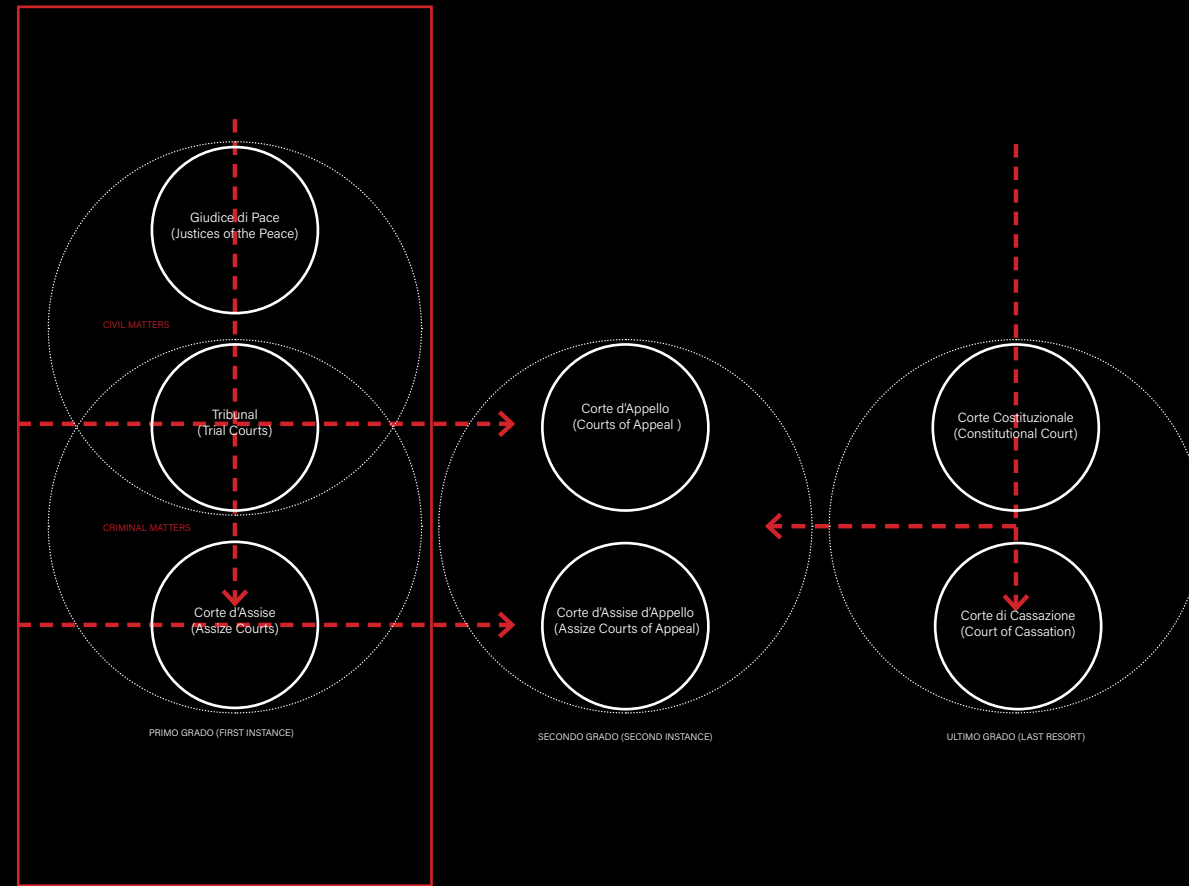

THRESHOLDS OF MILAN



WALLS

THRESHOLDS OF MILAN



Cosmasina
Nuova
Orientale
Vercellina
Ticinese
Romana

Roman gates
Medieval gates
Spanish gates



GATES

THRESHOLDS OF MILAN



MONUMENTAL IMPRESSION

THRESHOLDS OF MILAN

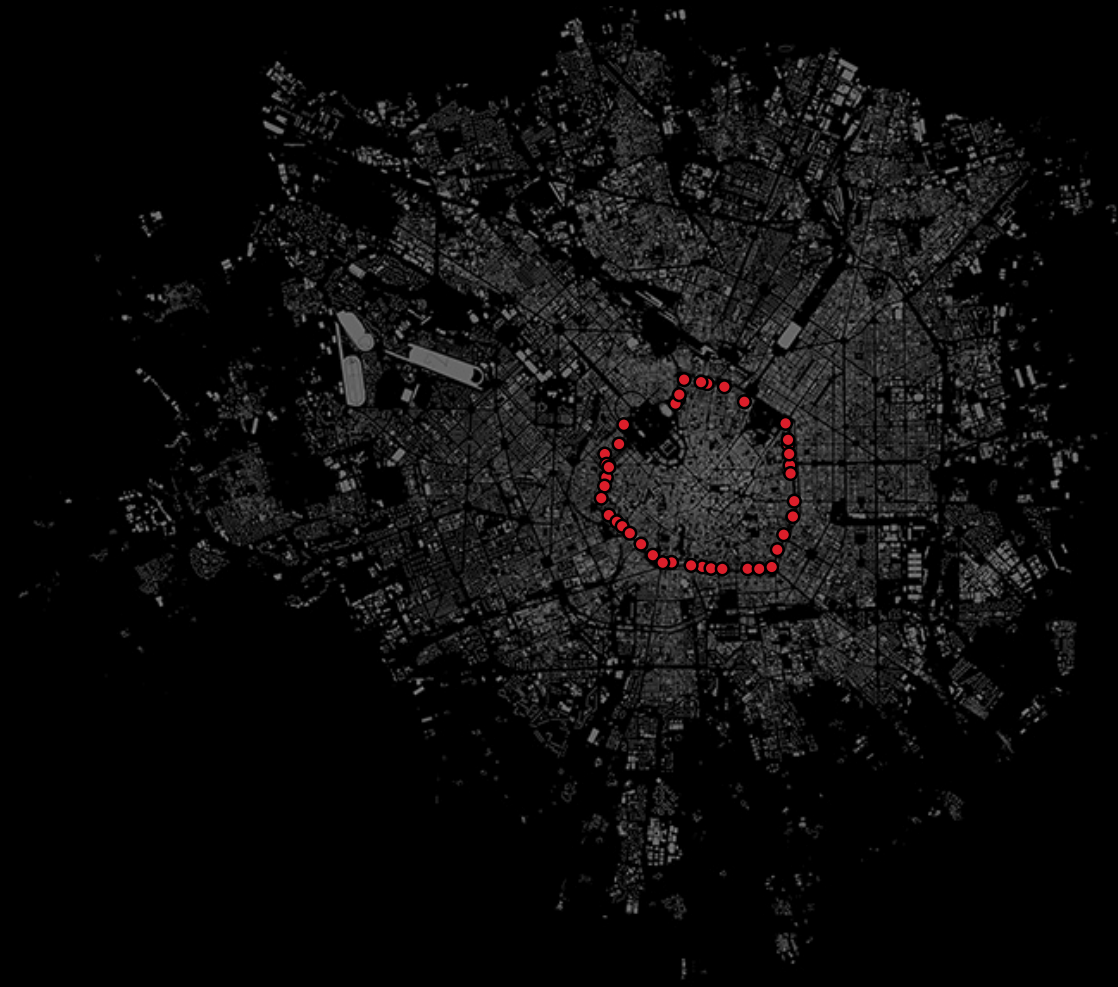

CAMERAS ZONE C

THRESHOLDS OF MILAN



CAMERAS ZONE B

POWER IN JUDICIAL STRUCTURE

JUDICIAL STRUCTURES

ENCLOSED SPACES/INCREASE OF POWER THRESHOLDS

1940



Medieval Period (1200s-1500s):

The Rise of City-States and Legal Pluralism



Renaissance to Enlightenment (1500s-1700s):

Centralization and Codification



Unification and Modernization (1800s-1900s):

The Napoleonic Influence and Legal Reforms



Contemporary Period (1900s-Present):

Democratic Institutions and Judicial Challenges



THRESHOLDS PERCEPTION

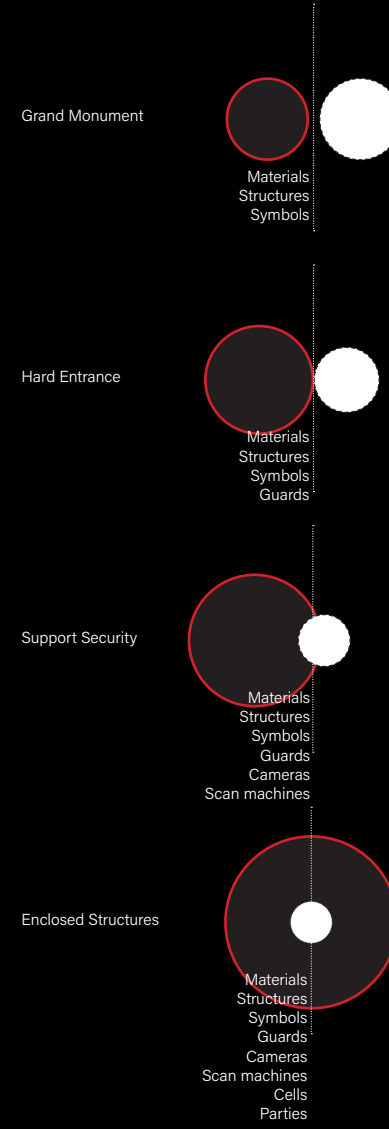

THRESHOLDS OF COURTHOUSE

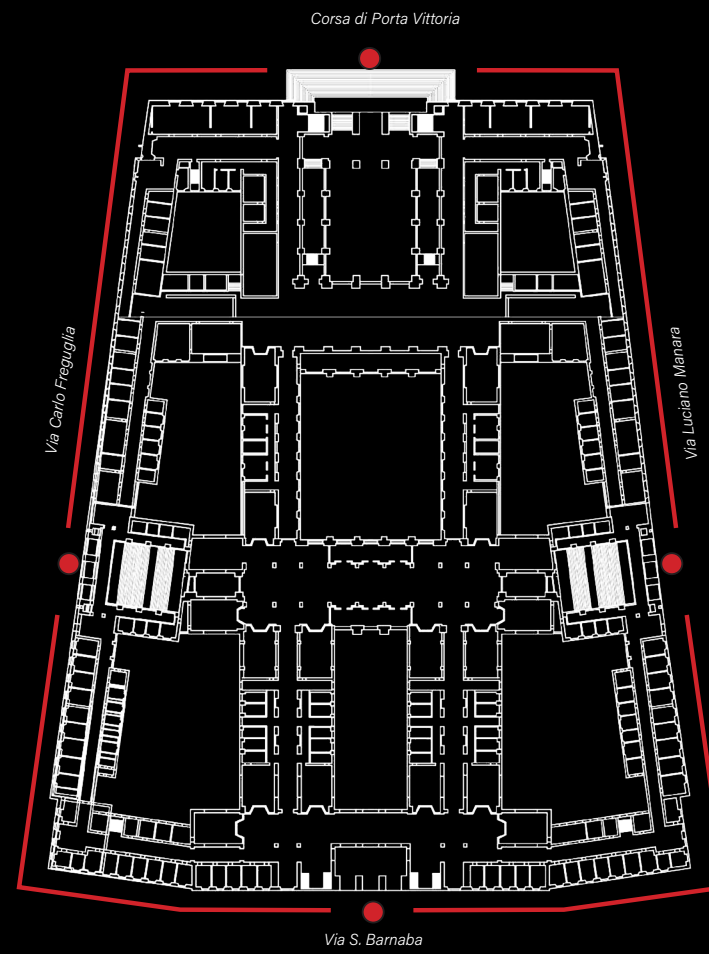

BORDERS AND ENTRANCES

THRESHOLDS OF COURTHOUSE

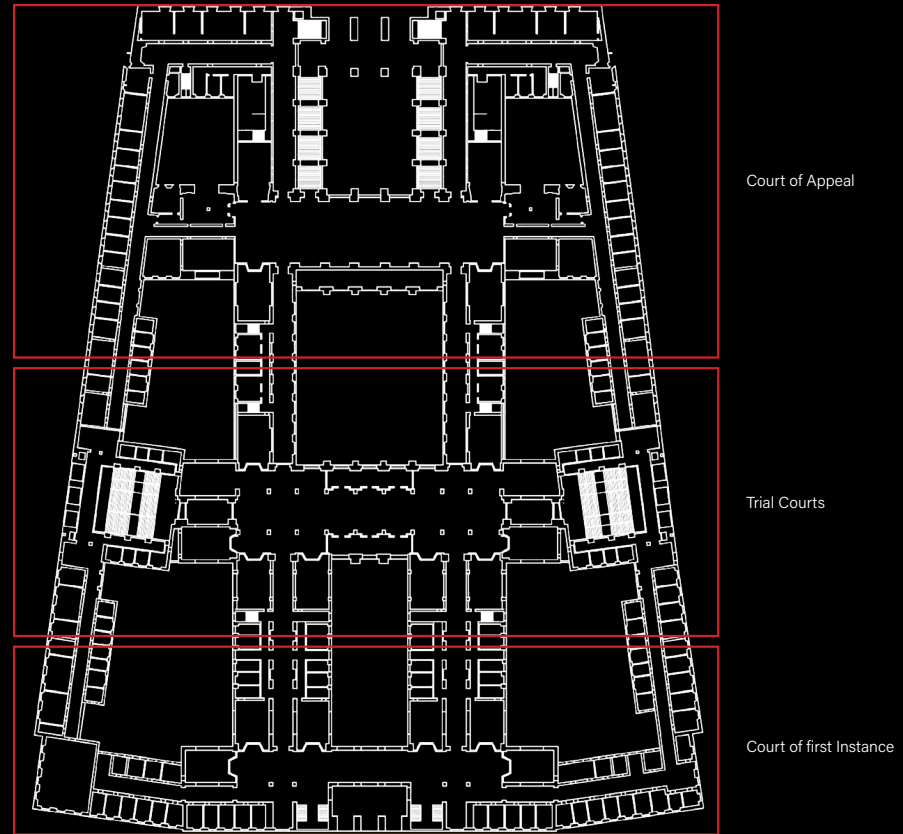

ZONING OF COURTS

THRESHOLDS OF COURTHOUSE

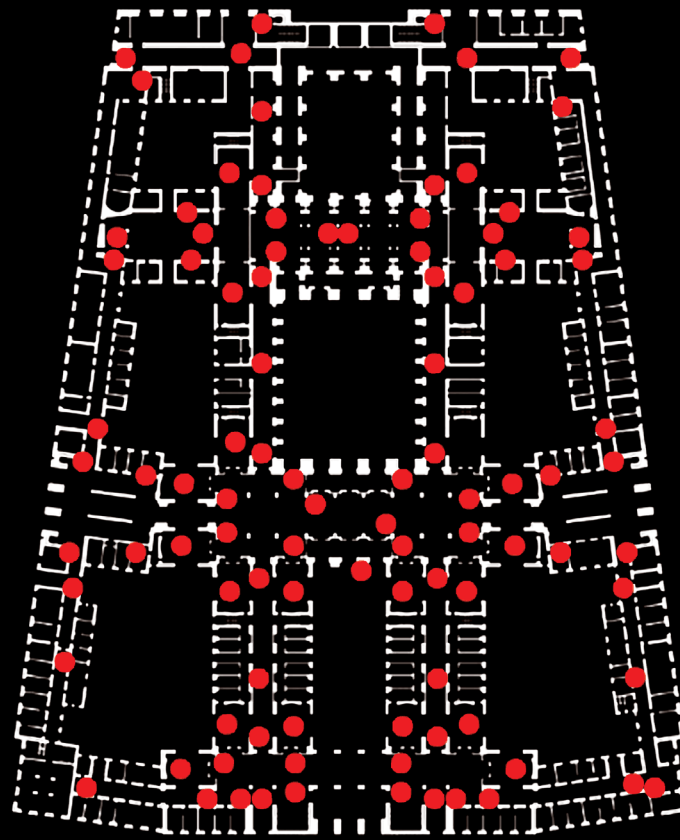

SECURITY CAMERAS

THRESHOLDS OF COURTHOUSE

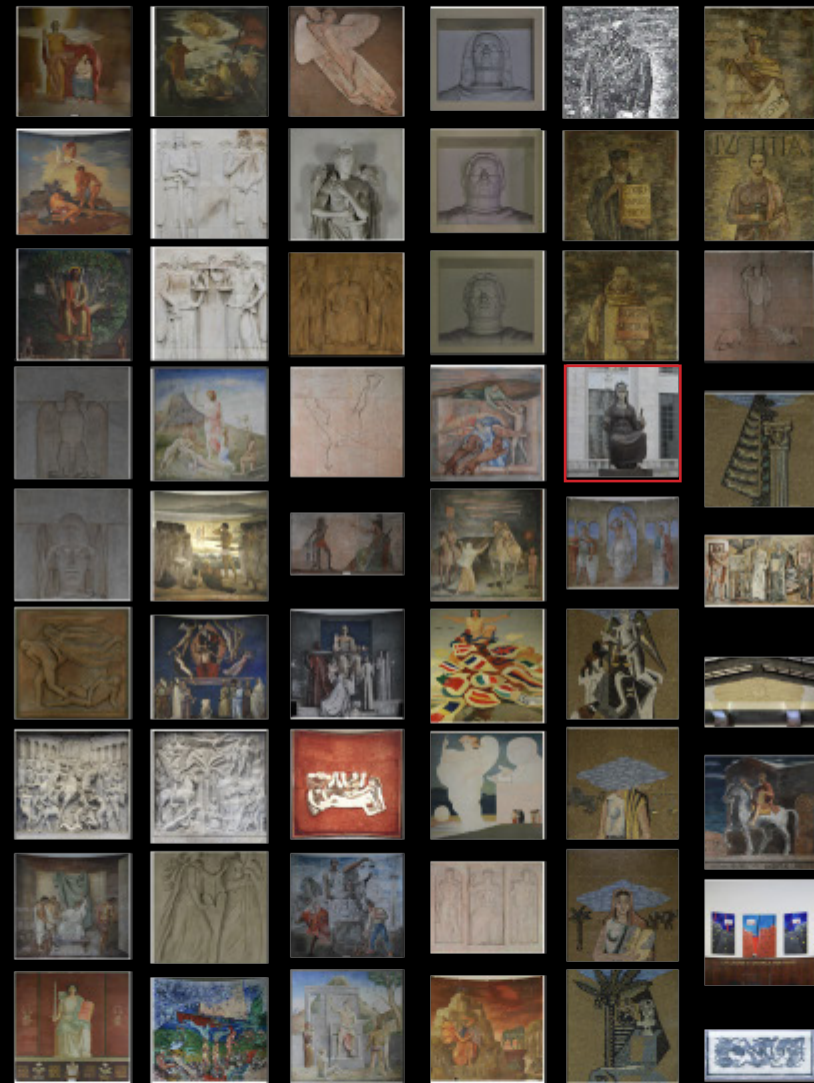

COLLECTION OF JUDICIAL ARTWORKS

THRESHOLDS OF COURTHOUSE

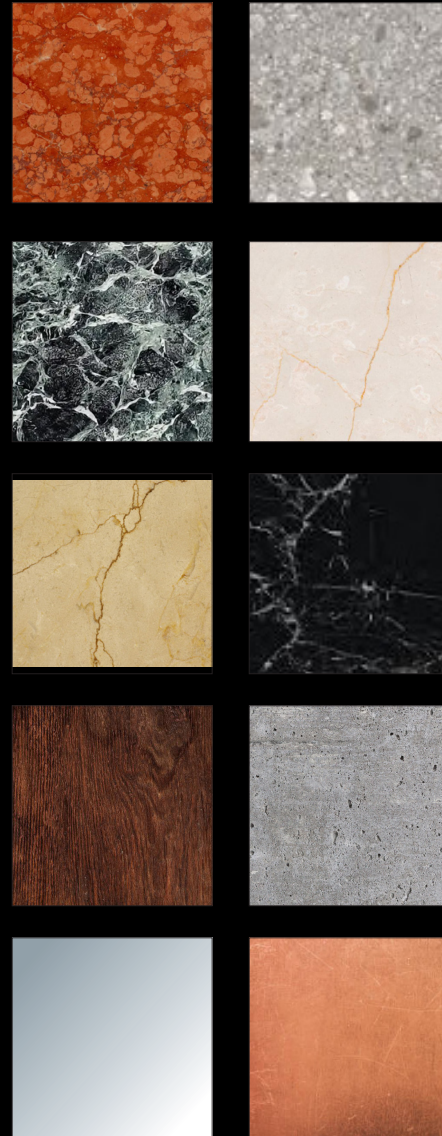

MATERIALITY

THRESHOLDS OF COURTHOUSE

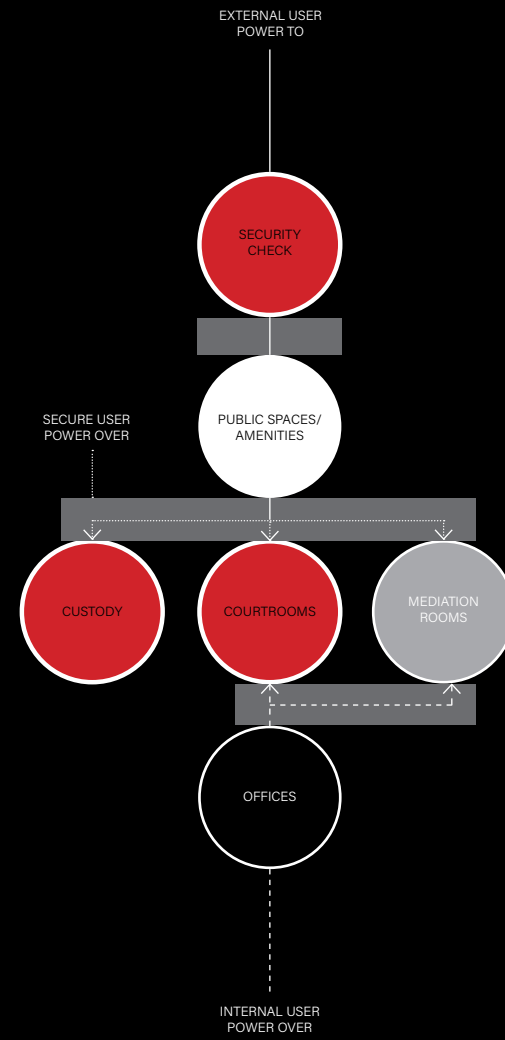

DISTRIBUTION OF PROGRAM

THRESHOLDS OF COURTHOUSE

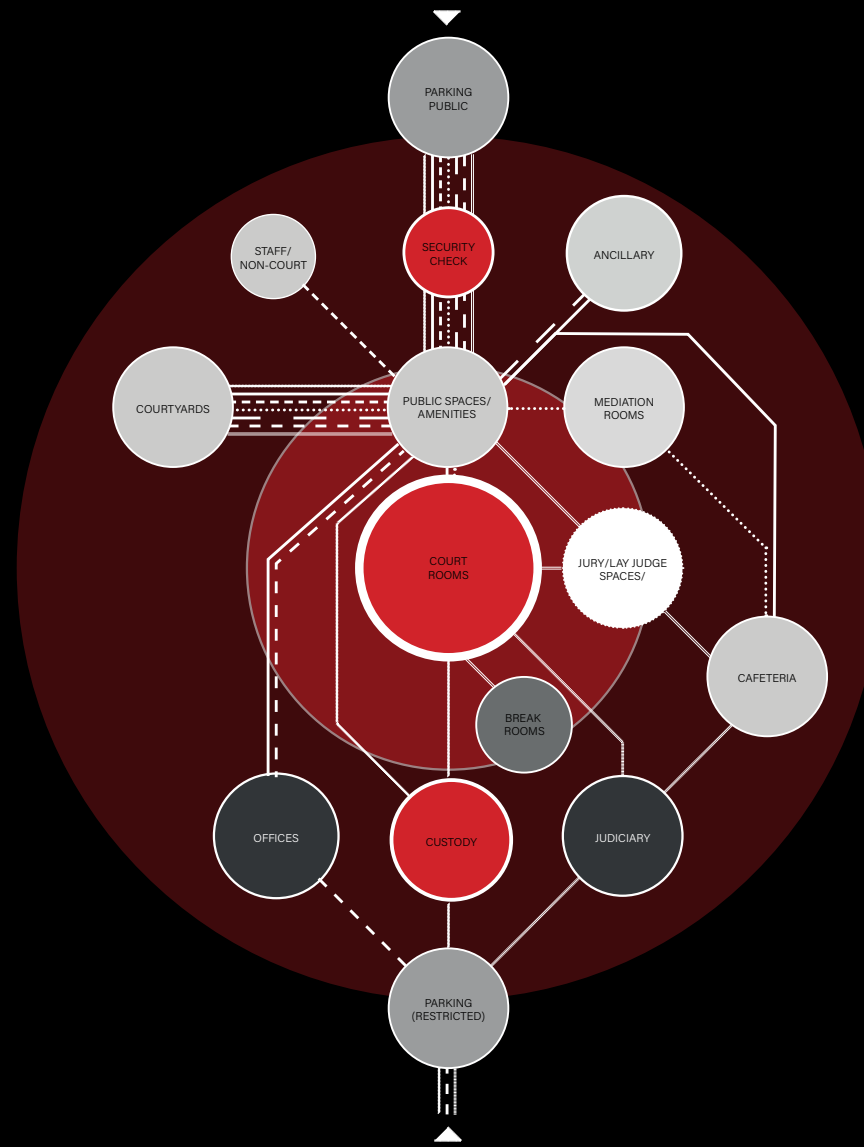

PROGRAM IN DETAIL

POWER IN COURTROOMS

THRESHOLDS OF COURTROOMS

X PUBLIC
Approx. 500 BC

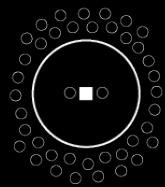

X SEMI PUBLIC
Approx. 500 BC - 500 CE

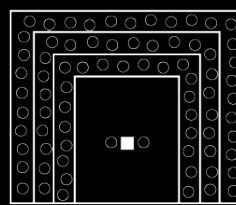

X 34
Approx. 1500 - 1800

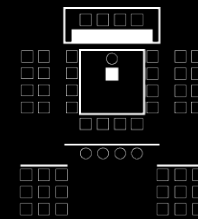

X 18
19th and 20th Century

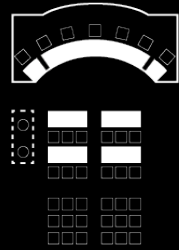

X 80
Late 20th Century

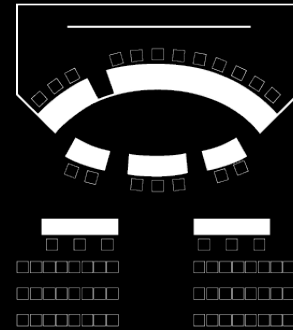

X PUBLIC
Future?

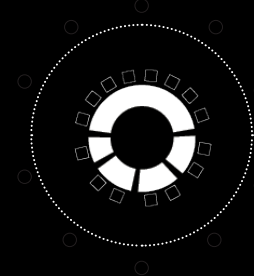

HISTORICAL SPACIAL ORIENTATION



THRESHOLDS OF COURTROOMS IN MILAN

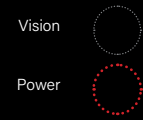
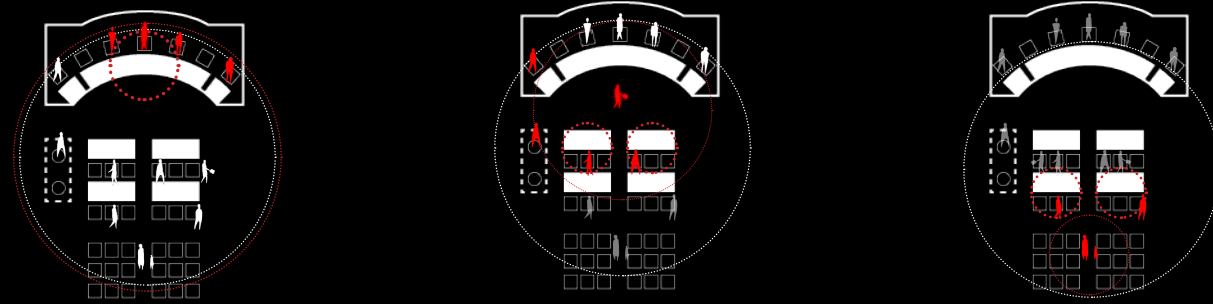

POWER RELATIONSHIPS

THRESHOLDS OF COURTROOMS IN MILAN

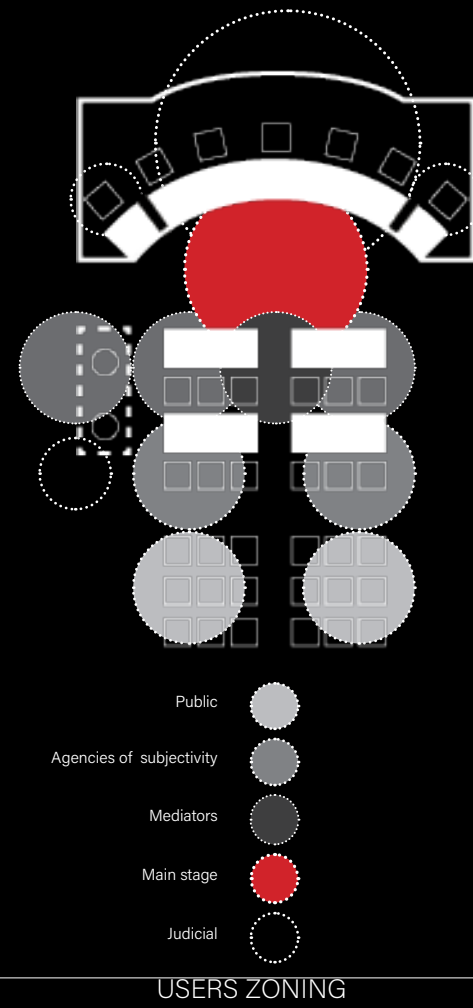

THRESHOLDS OF COURTROOMS IN AMSTERDAM

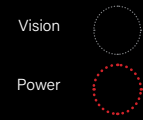
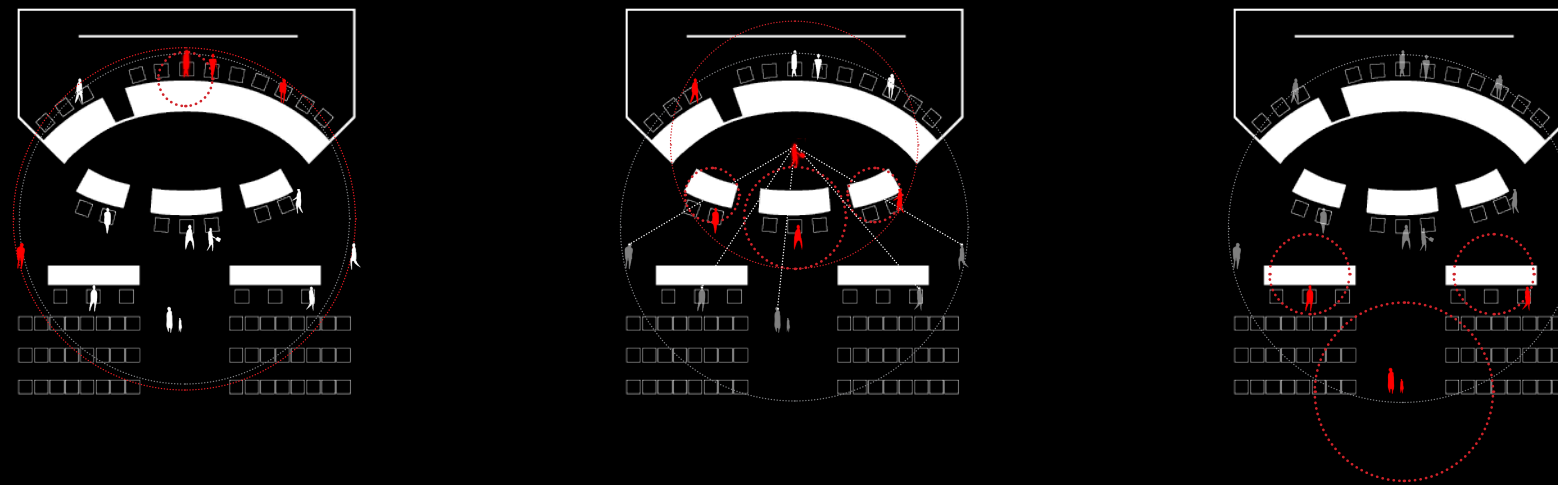

POWER RELATIONSHIPS

THRESHOLDS OF COURTROOMS IN AMSTERDAM

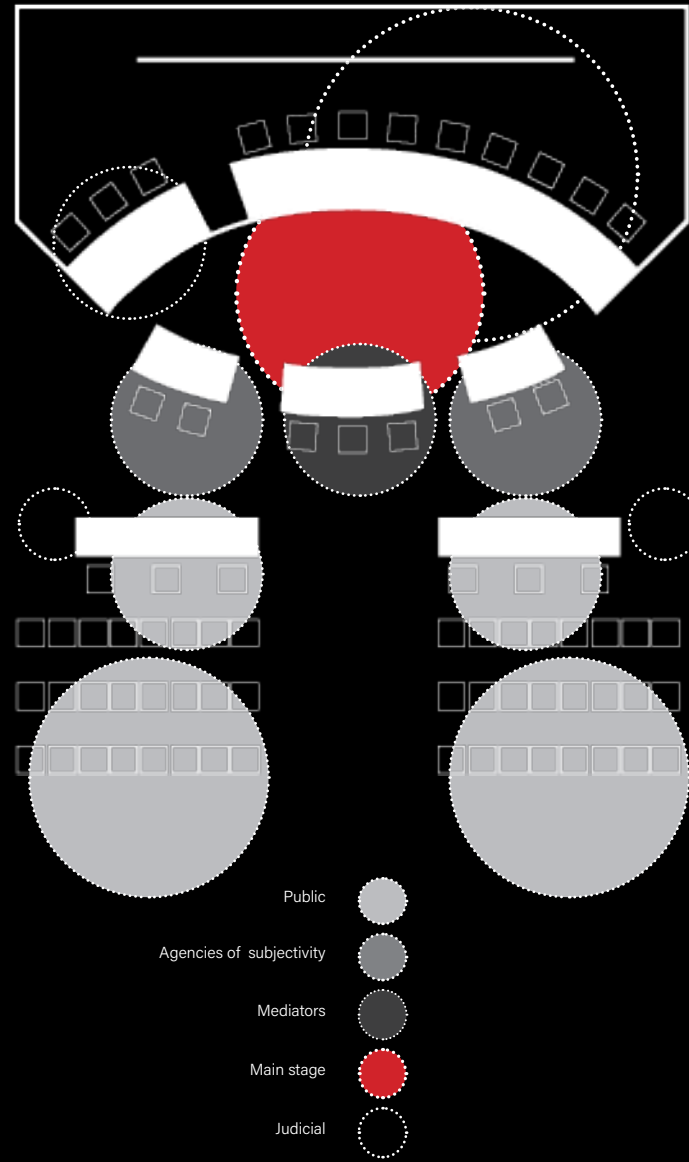

USERS ZONING

THRESHOLDS OF COURTROOMS

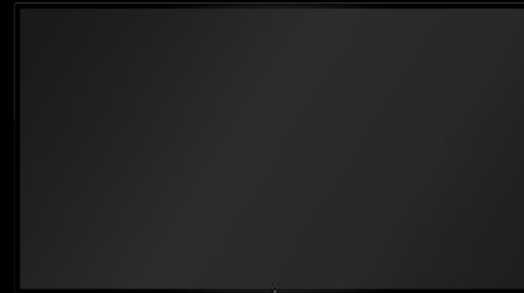
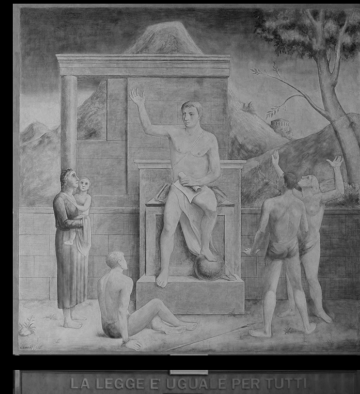

FURNITURES

WHAT NEEDS KEEPING

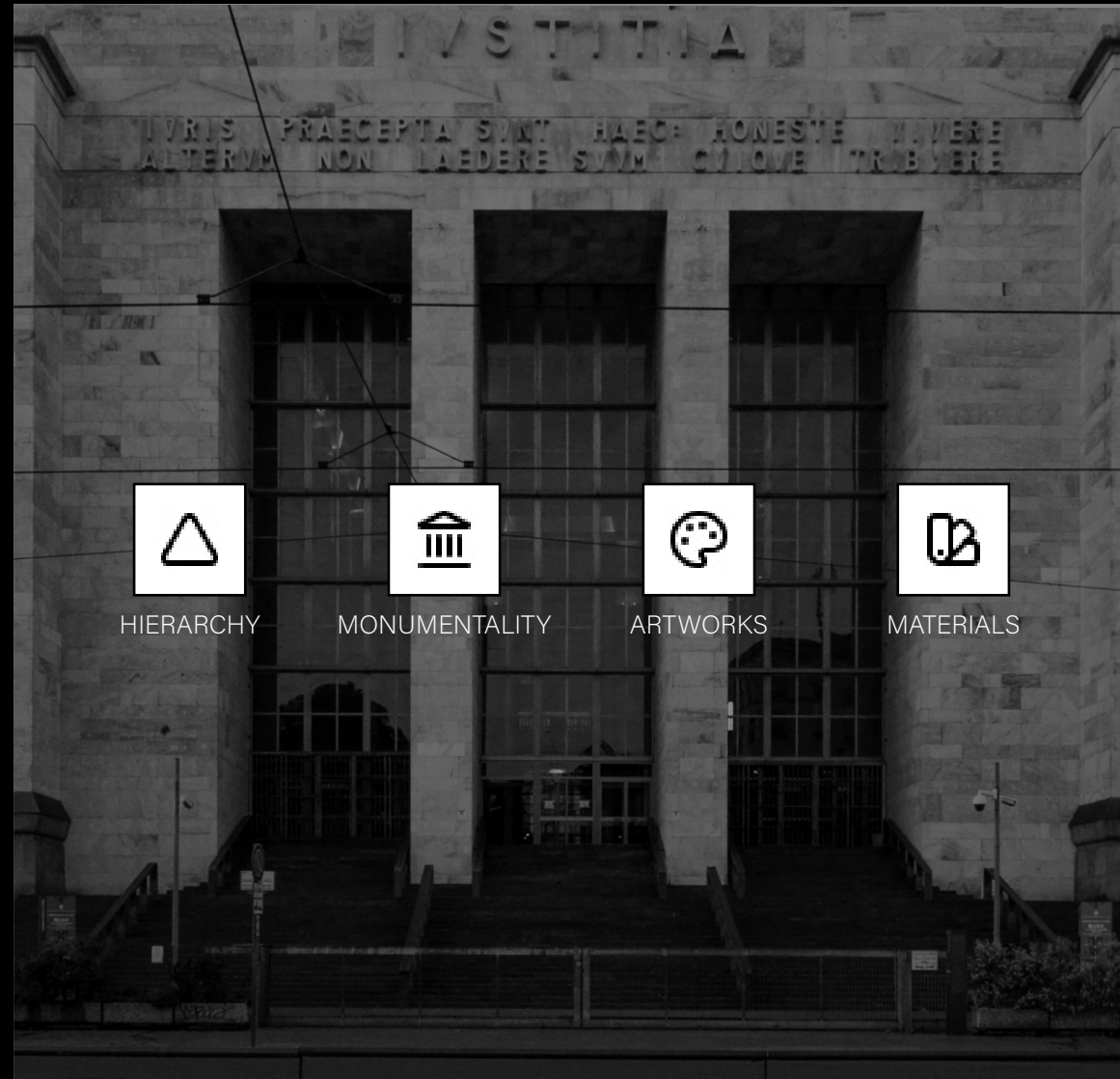

WHAT IS RECONSTRUCTION

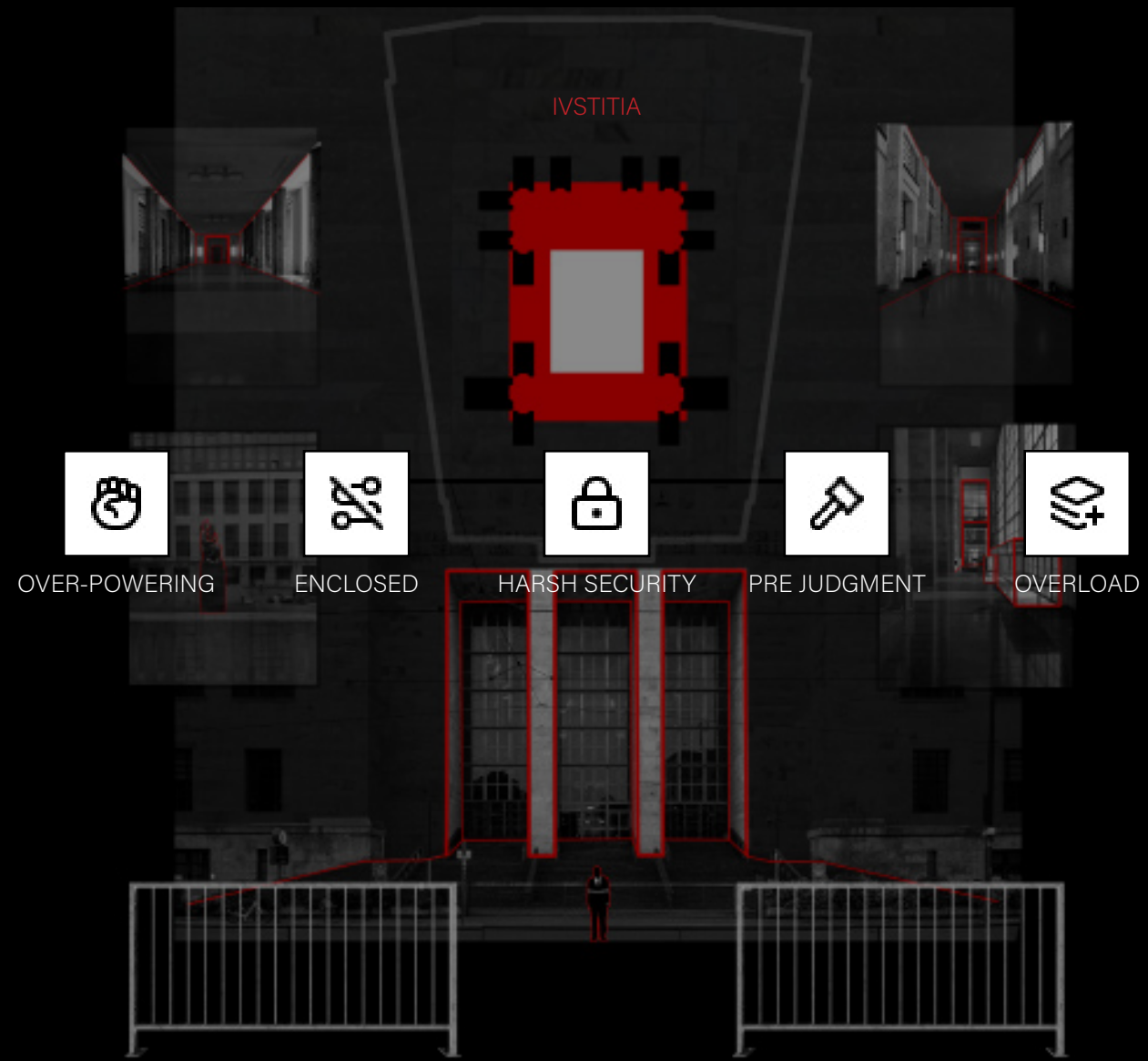

CONTENT

INTRODUCTION
THEORY
RESEARCH
CONCEPT
DESIGN BRIEF
DESIGN
TECHNICAL
CONCLUSION

POWER TO

JUDICIAL STRUCTURE

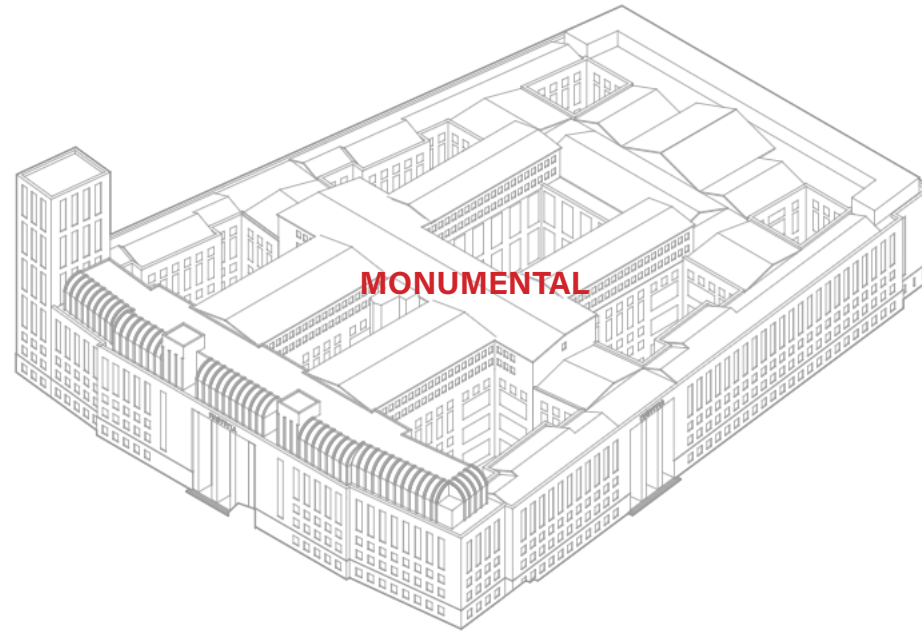

POWER THRESHOLD

JUDICIAL STRUCTURE

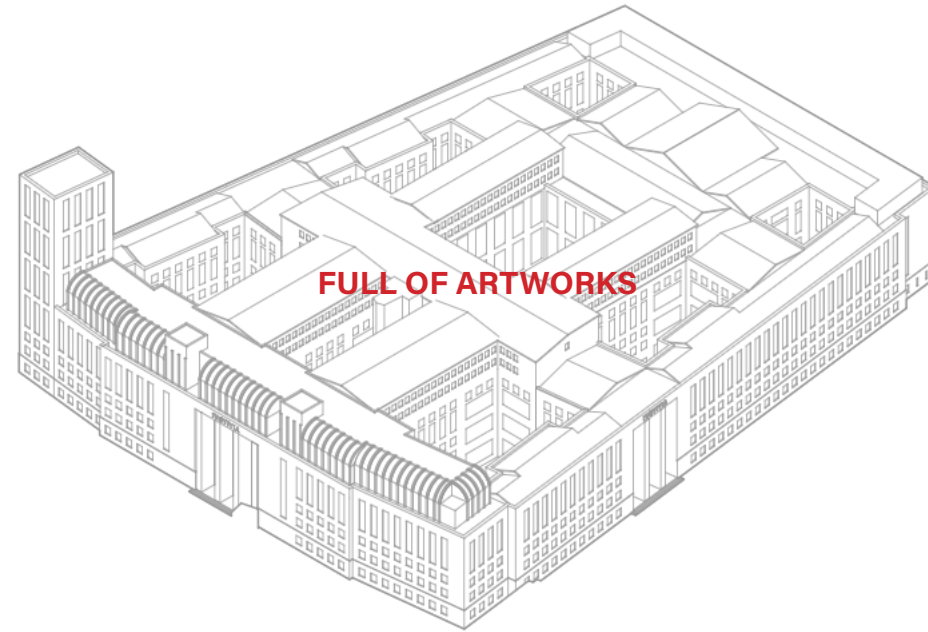

POWER THRESHOLD

JUDICIAL STRUCTURE

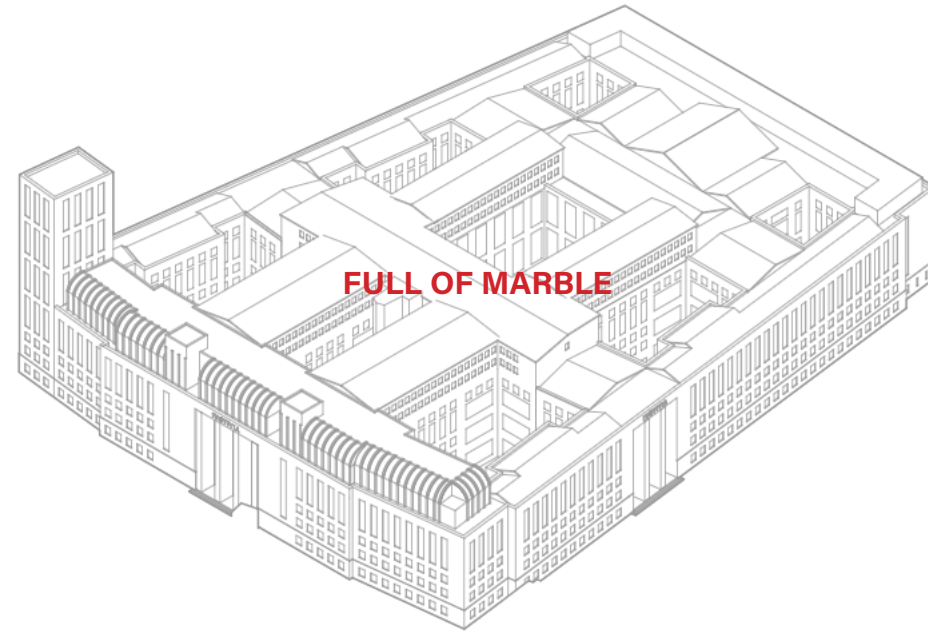

POWER THRESHOLD

JUDICIAL STRUCTURE

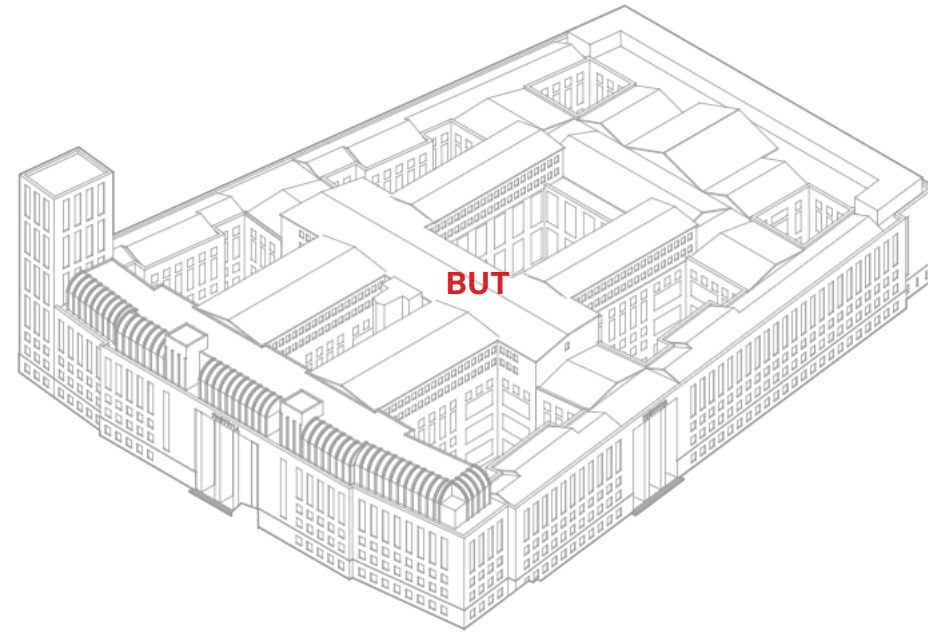

POWER THRESHOLD

JUDICIAL STRUCTURE

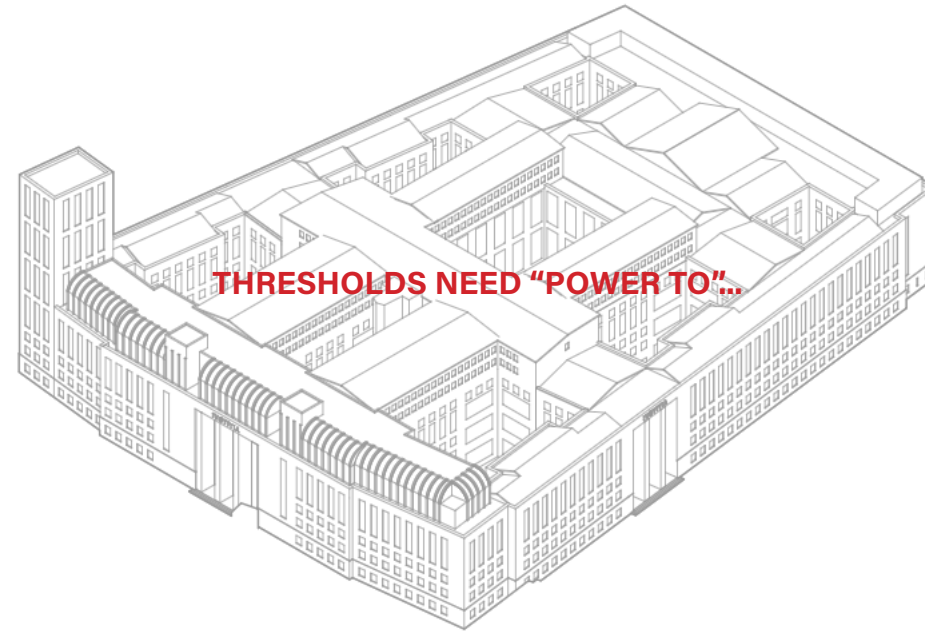

POWER THRESHOLD

JUDICIAL STRUCTURE

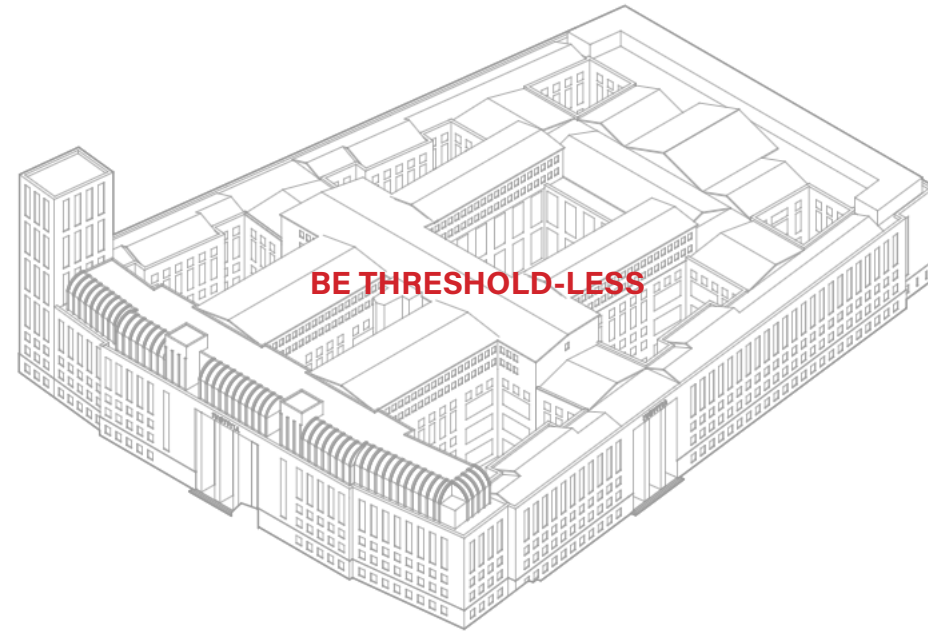

POWER THRESHOLD

JUDICIAL STRUCTURE

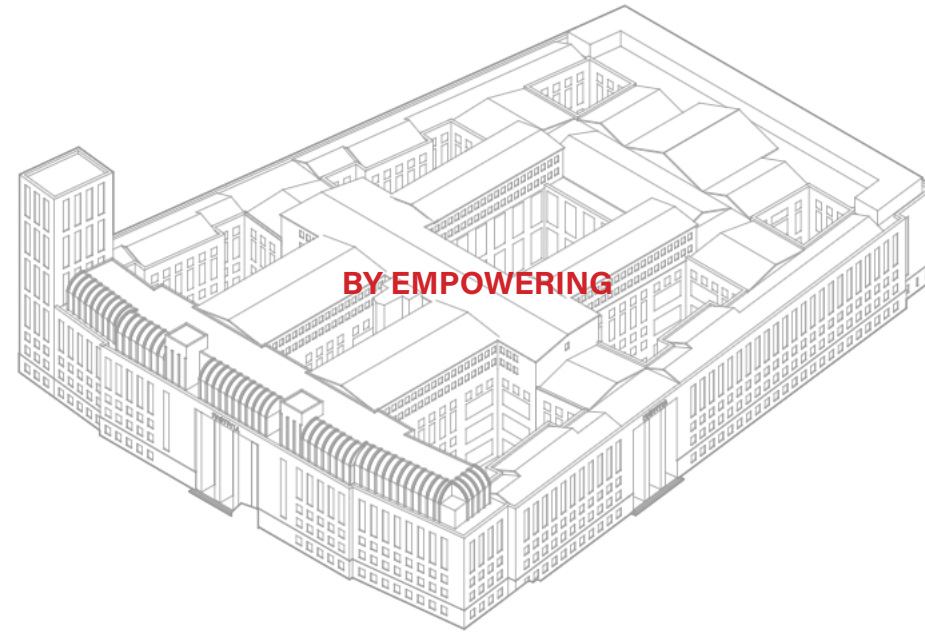

POWER THRESHOLD

STATE/PUBLIC RELATION

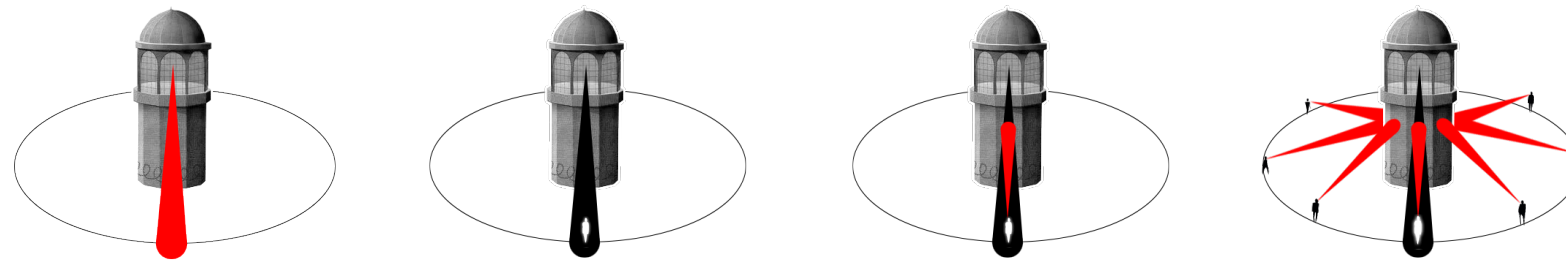

STATE POWER OVER

STATE/PUBLIC RELATION

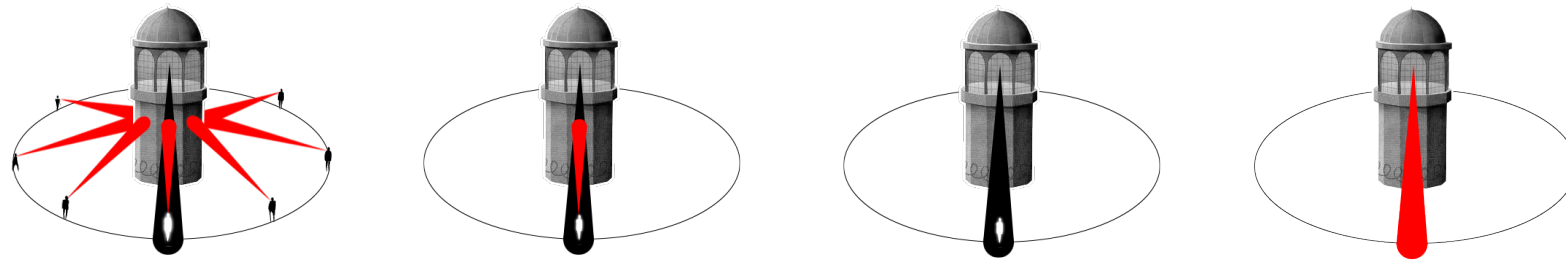

CIVIC POWER TO

CENTRALIZED SCHEME

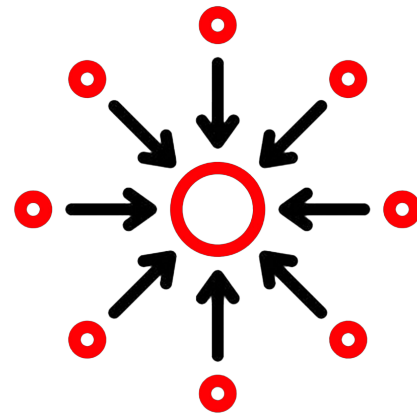

STATE POWER OVER

DECENTRALIZED SCHEME

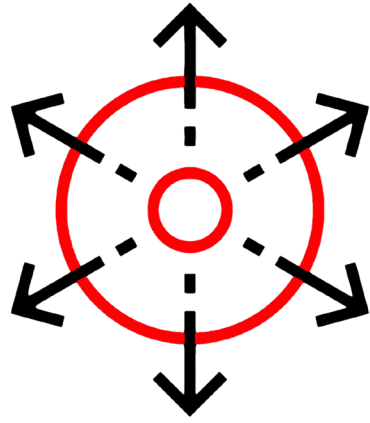

CIVIC POWER TO

DECENTRALIZED SCHEME

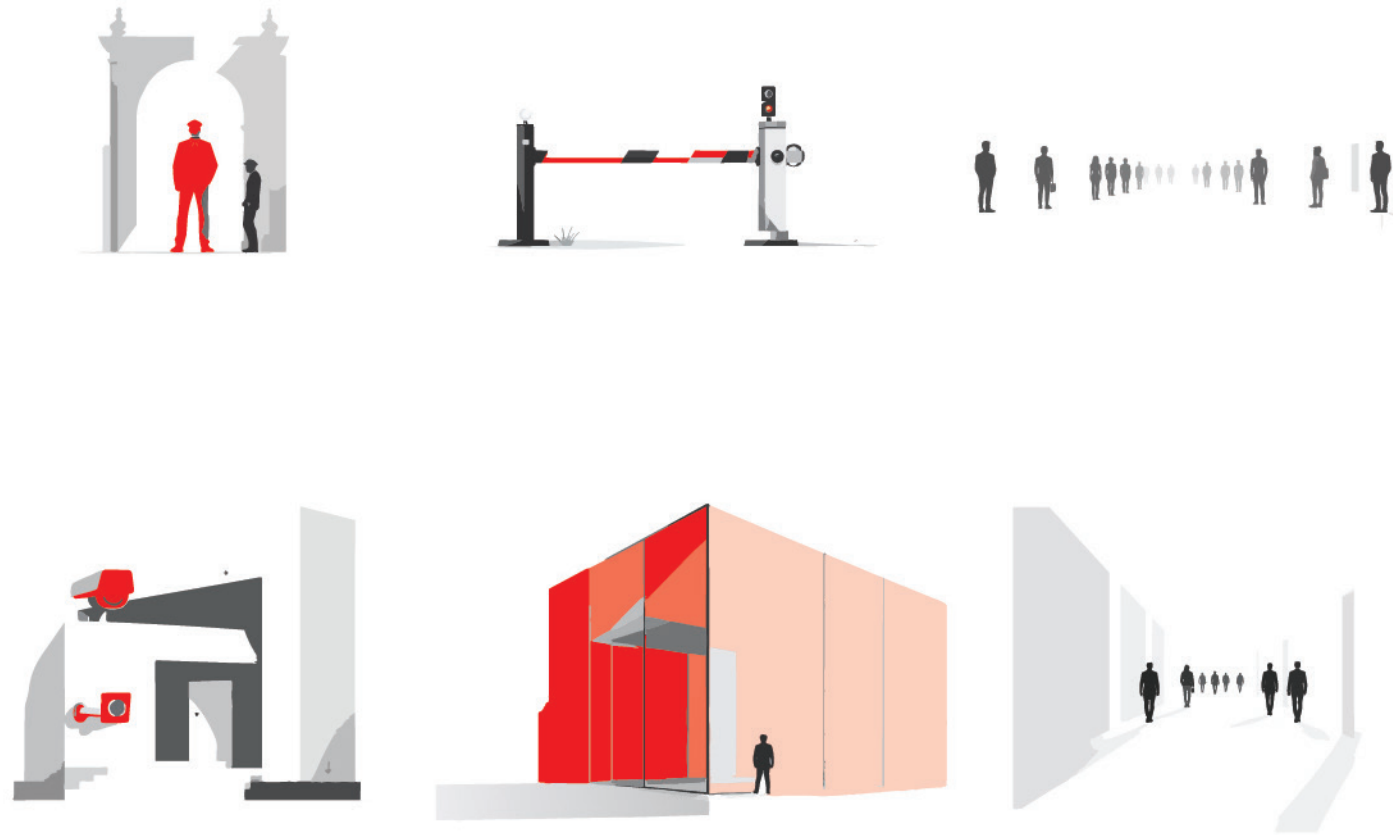

REFLECTIVE AND REACTIVE, NOT PREVENTIVE

CENTRALIZED SCHEME

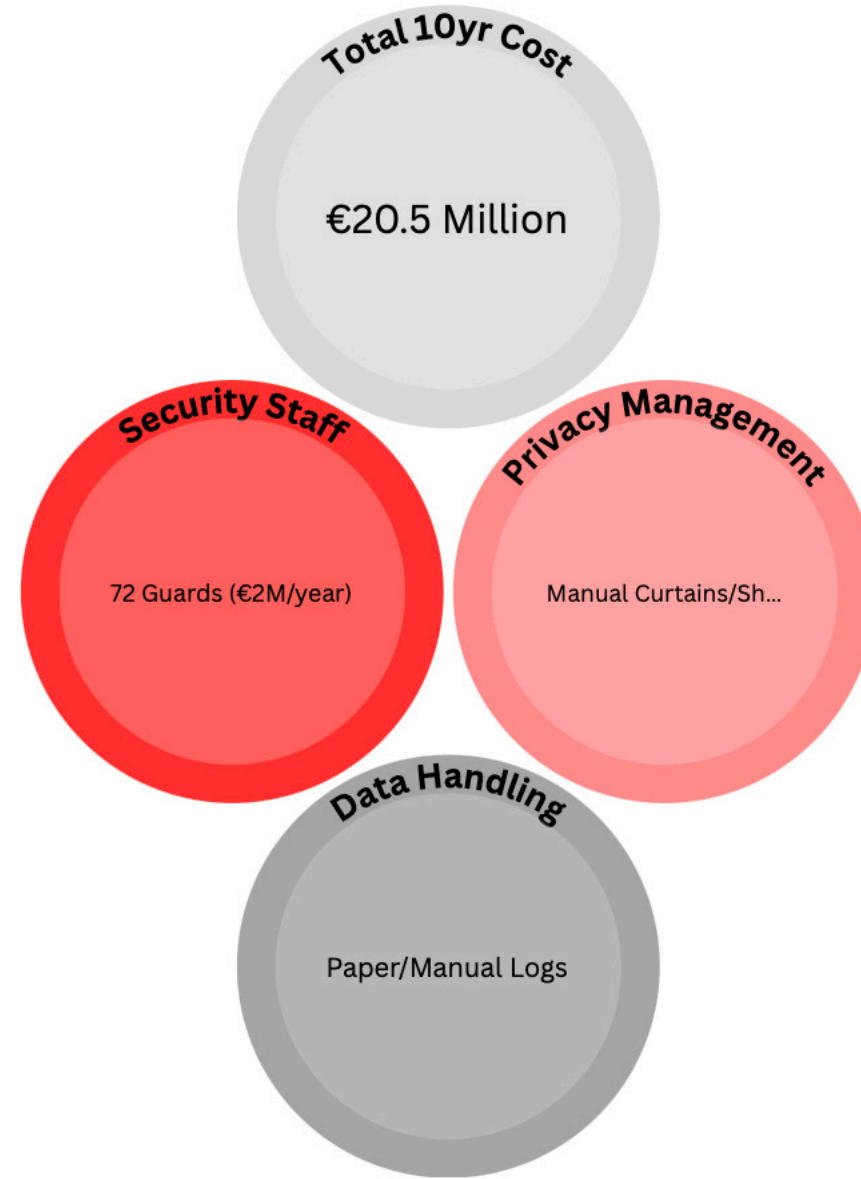

TOOLS OF DECENTRALIZATION

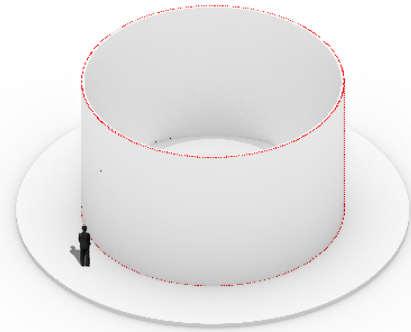

Monumentality

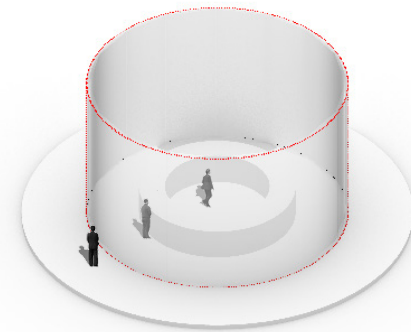

Transparency

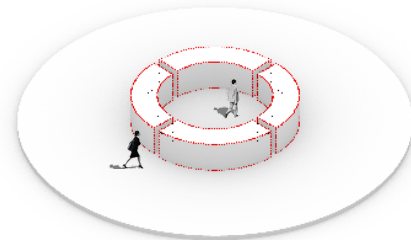

Adoptability

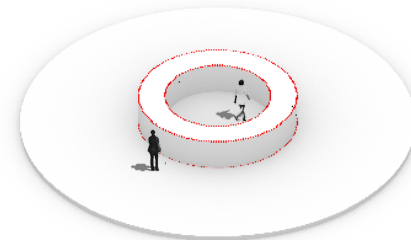

Multi-functionality

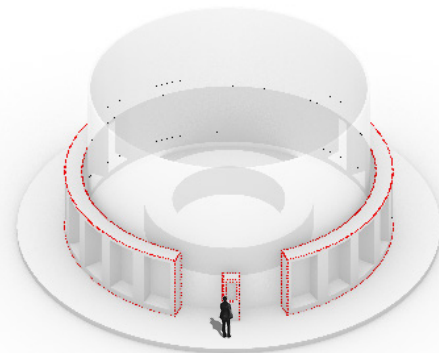

Digitalization

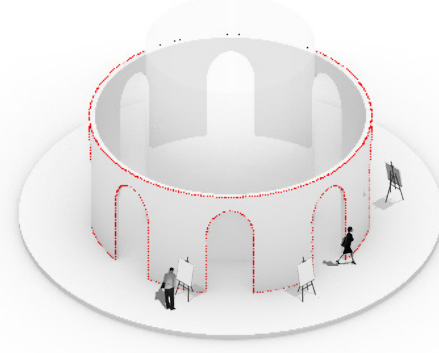

Reflection

CONTENT

INTRODUCTION

THEORY

RESEARCH

CONCEPT

DESIGN BRIEF

DESIGN

TECHNICAL

CONCLUSION

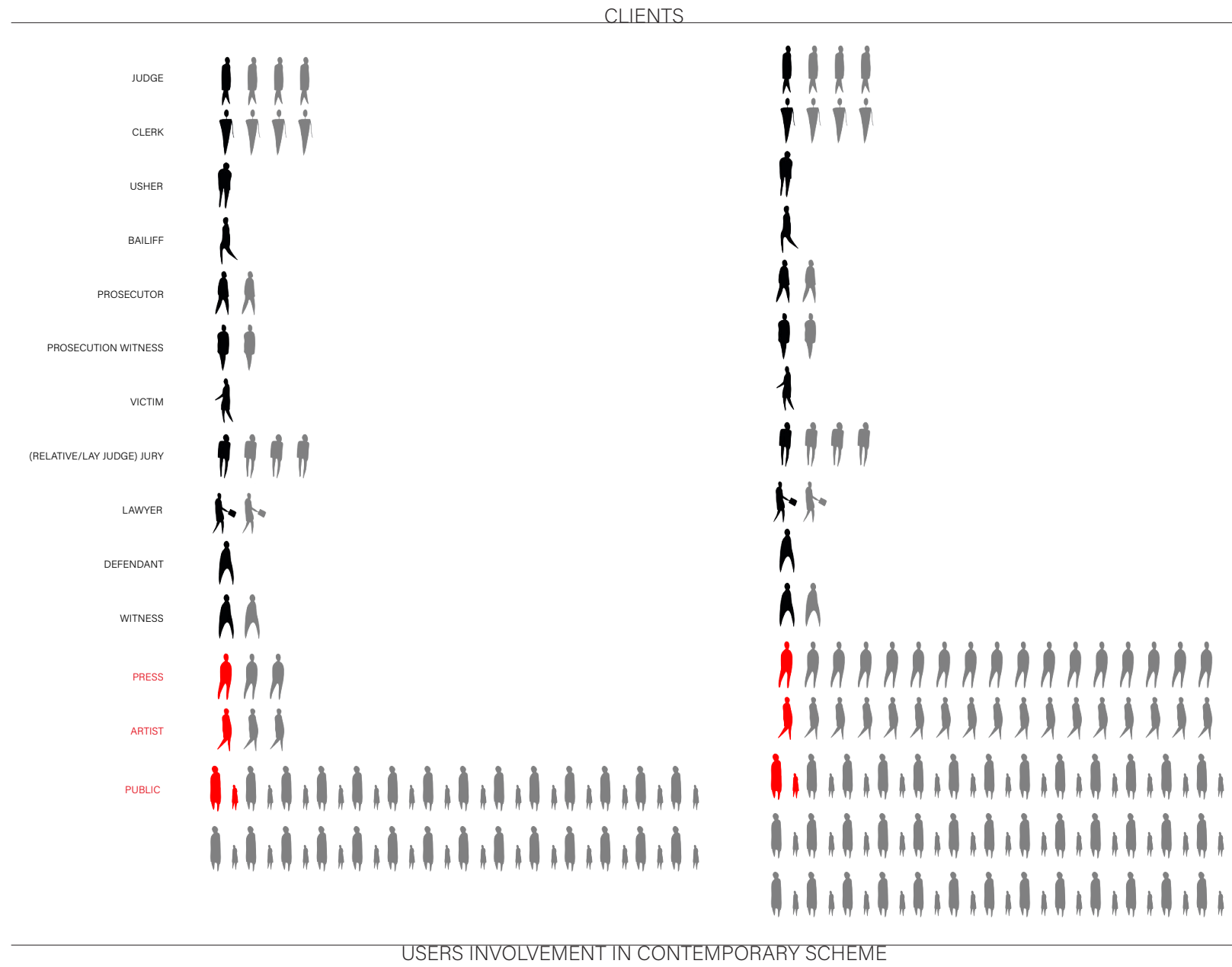

CLIENTS

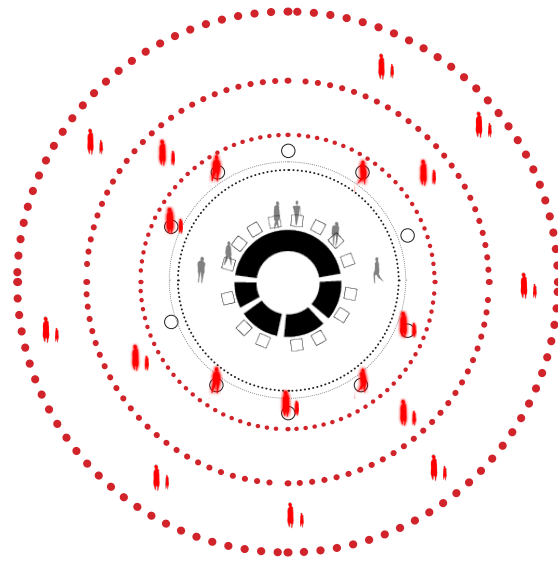

POWER RELATIONSHIP

CLIENTS

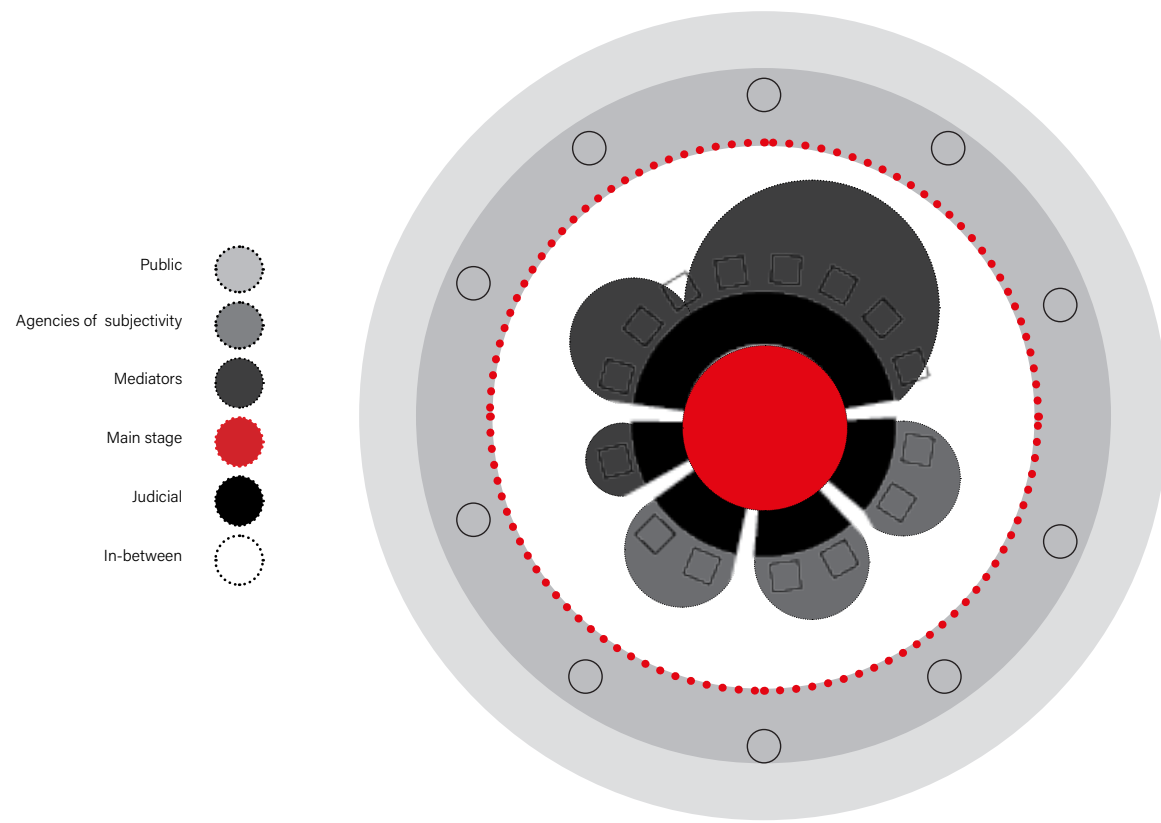

ZONING SCHEME

PROGRAM SCHEME

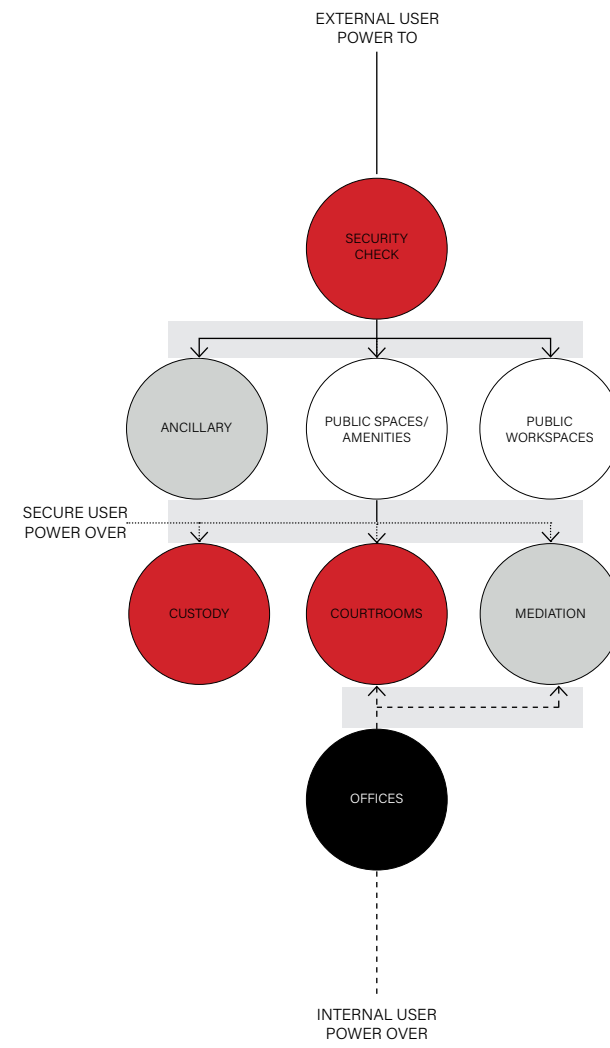

PROGRAM DISTRIBUTION

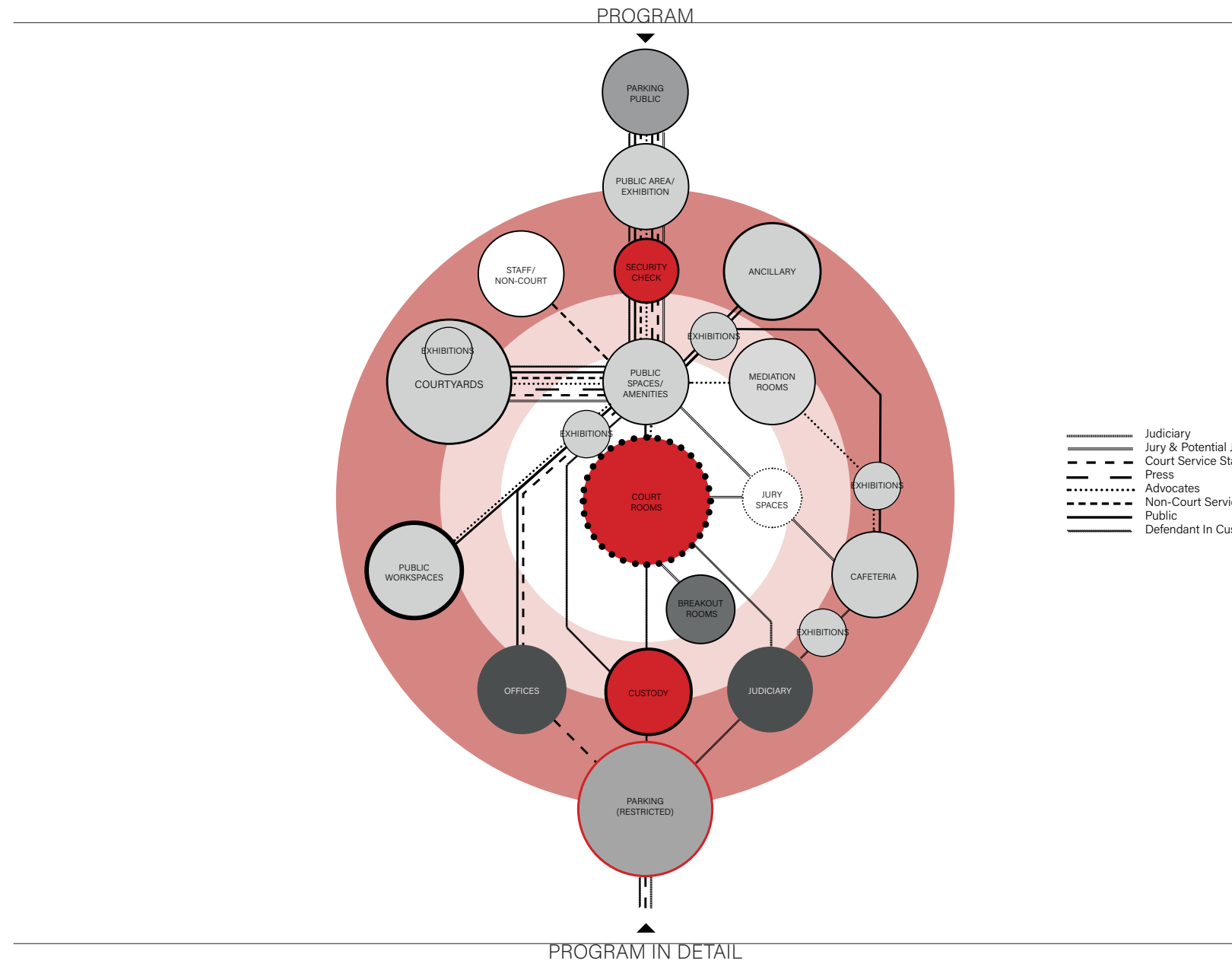

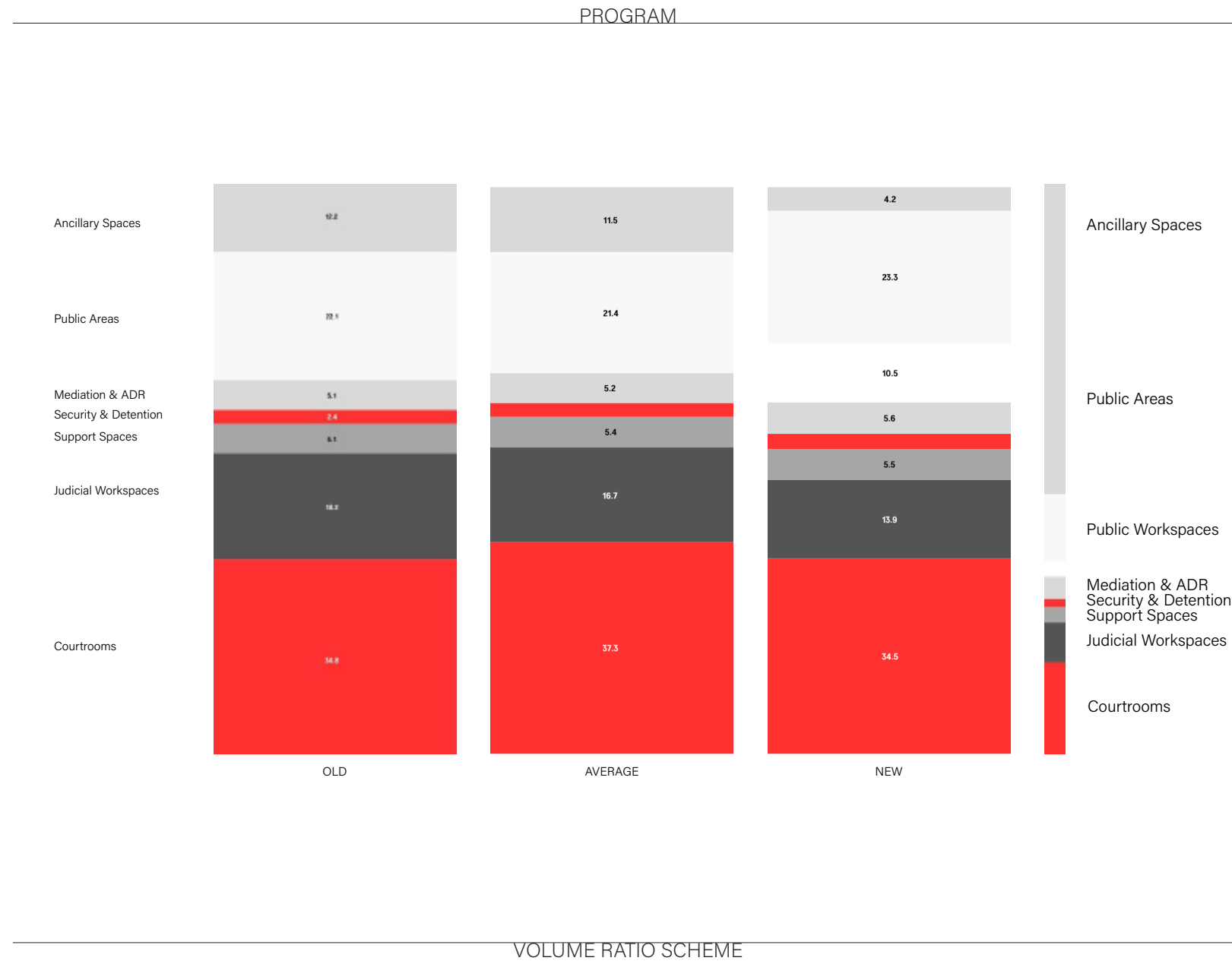

PROGRAM

main program	program in detail
Courtrooms	Trial Courts Specialized Courtrooms Hearing Spaces
Judicial Workspaces	Judges' Chambers Prosecutors' Offices Public Defenders' Hubs Administrative Offices
Support Spaces	File/Evidence Storage Staff Break Spaces IT/Server Rooms
Security & Detention	Holding Cells Security Checkpoints Secure Transfer Routes
Mediation & ADR	Mediation Rooms Conference Rooms (ADR-focused)
Public Areas	Lobby & Atrium Waiting Areas Public Cafeteria Courtyard / Piazza
Ancillary Spaces	Parking (Staff/Public) Press Spaces Libraries

SPACES IN DETAIL

PROGRAM

main program	program in detail
Courtooms	<ul style="list-style-type: none"> 60 Smart Courtrooms Specialized Courtrooms Hearing Spaces
Judicial Workspaces	<ul style="list-style-type: none"> Judges' Chambers Prosecutors' Offices Public Defenders' Hubs Administrative Offices
Support Spaces	<ul style="list-style-type: none"> Digitalized Data Centre Staff Break Spaces IT/Server Rooms
Security & Detention	<ul style="list-style-type: none"> Victim/Witness Lounges Holding Cells Security Checkpoints Screening Transfer Routes
Mediation & ADR	<ul style="list-style-type: none"> Mediation Rooms Conference Rooms (ADR-focused)
Public Areas	<ul style="list-style-type: none"> Lobby & Atrium Waiting Areas Public Cafeteria Educational centre Courtyard / Piazza Internal Garden / Foyer Garden External Portico
Public Workspace	<ul style="list-style-type: none"> Libraries Art/Media Centre Broadcast Centre Exhibition Space Reflection Spaces
Ancillary Spaces	<ul style="list-style-type: none"> Parking (Staff/Public)

SPACES IN DETAIL

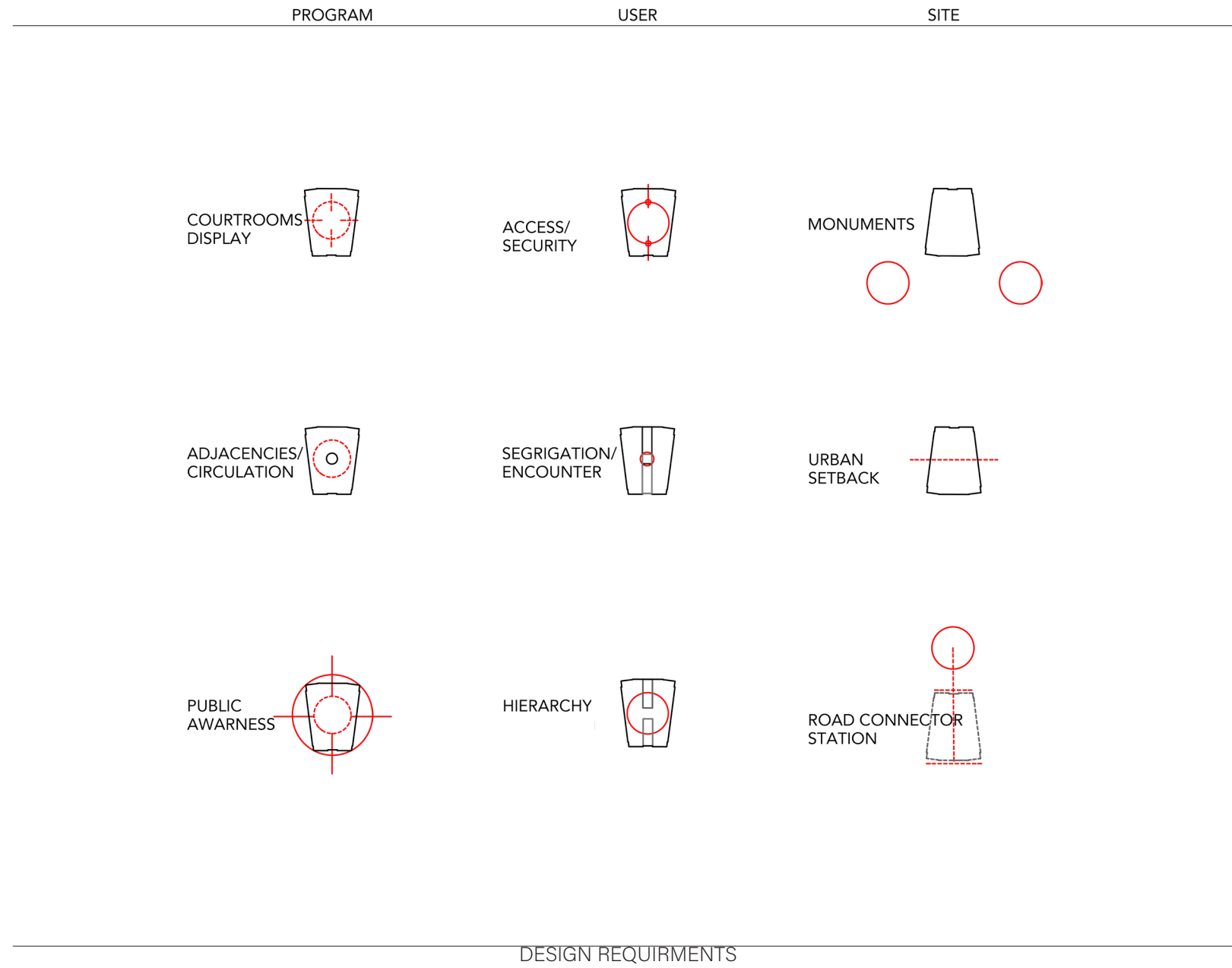

OLD MODELS



NEW MODELS

BASE

CELLINGS

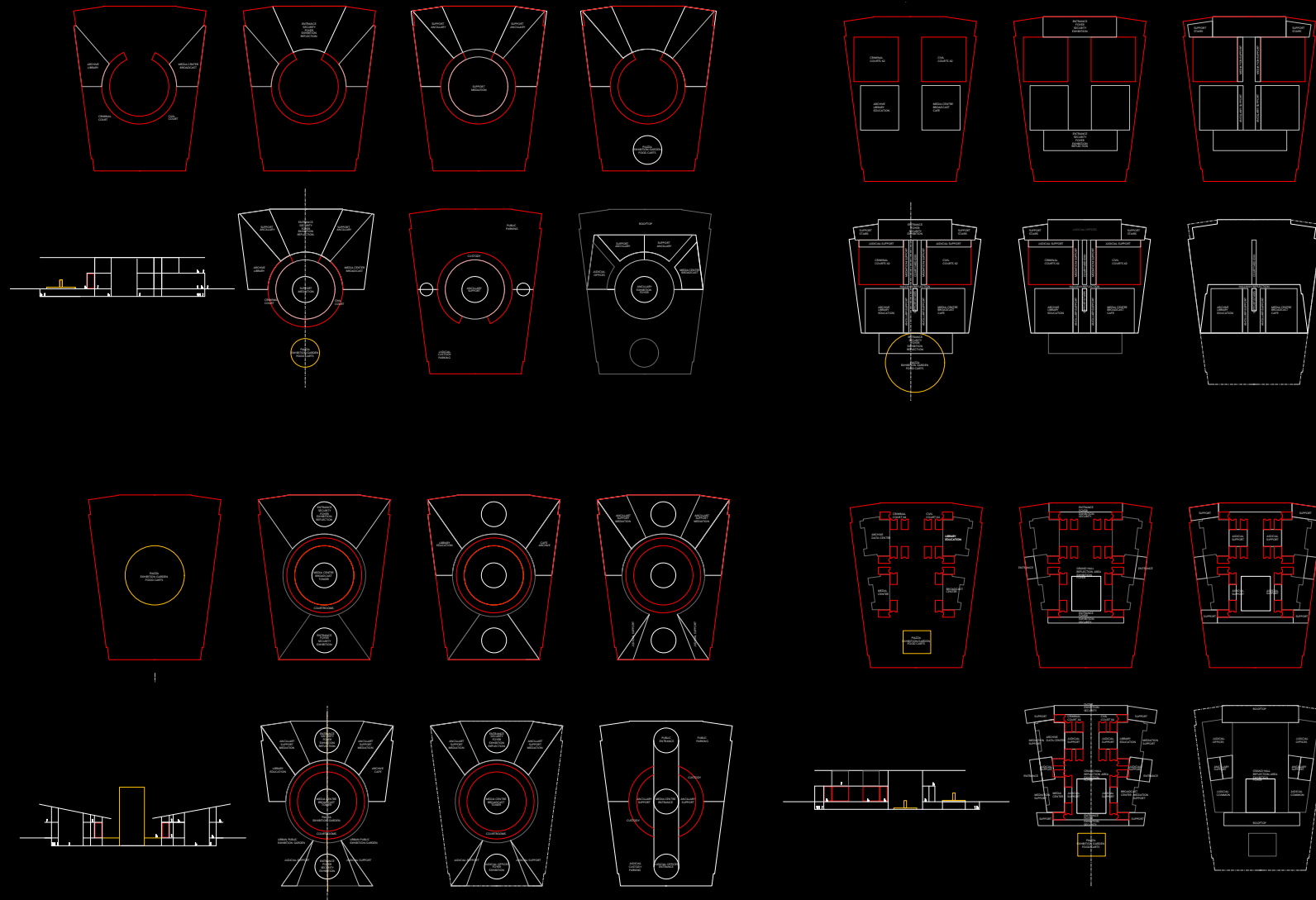

CONTENT

INTRODUCTION
THEORY
RESEARCH
CONCEPT
DESIGN BRIEF
DESIGN
TECHNICAL
CONCLUSION

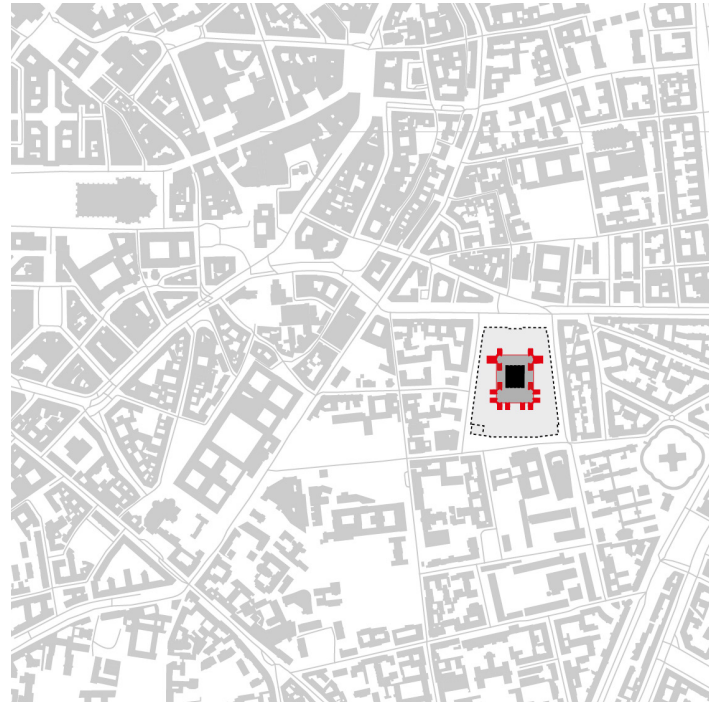

Heritage

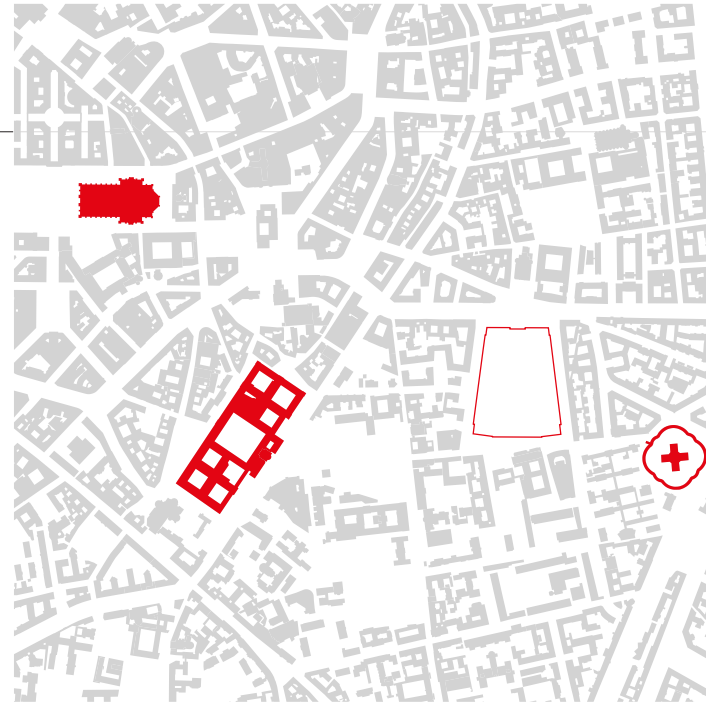

Monuments

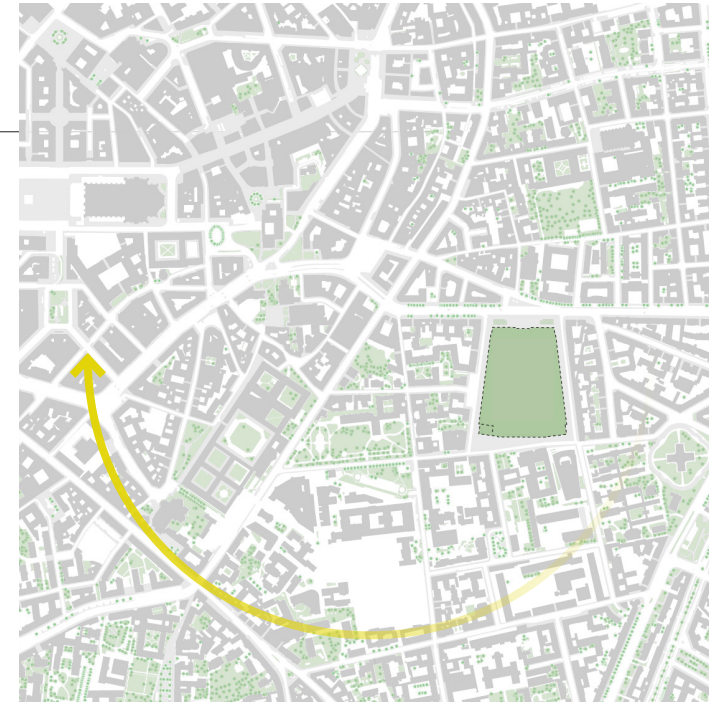

Ecology

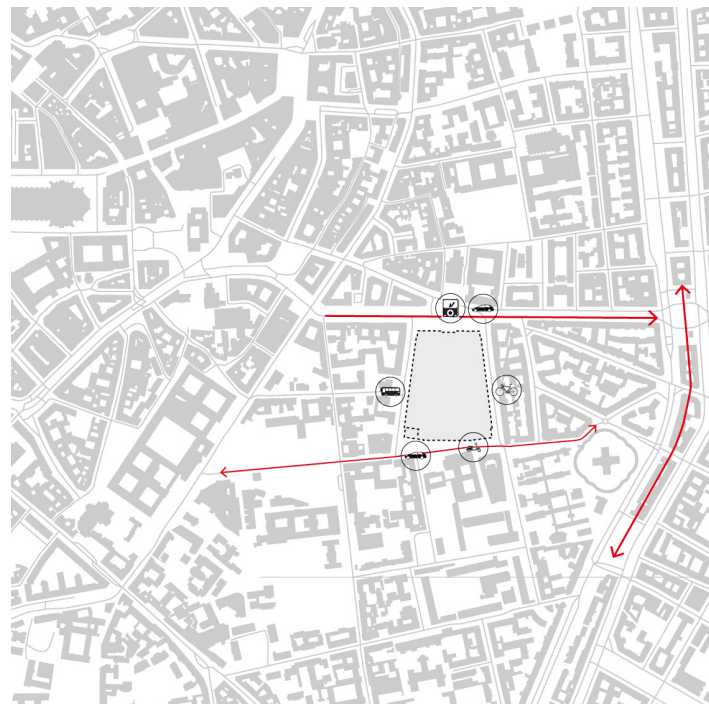

Accessibility

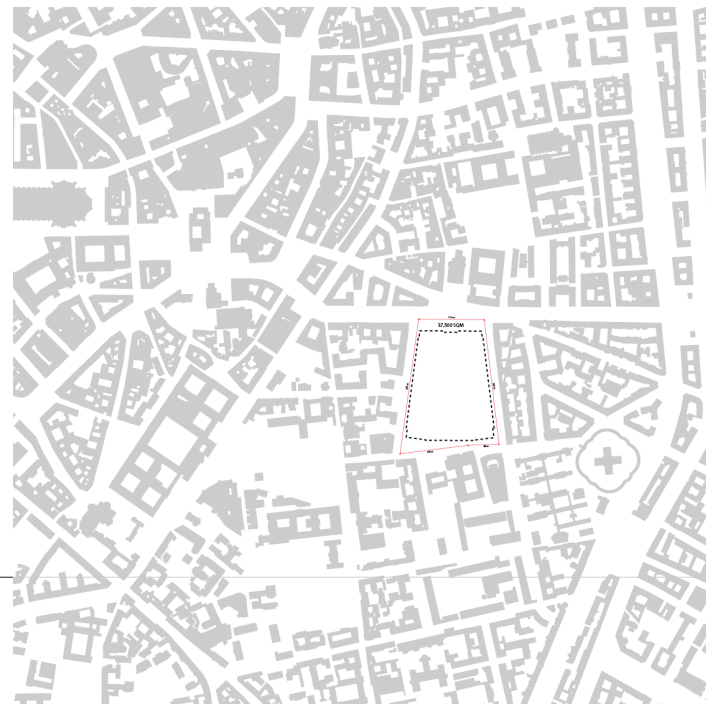

Dimensions

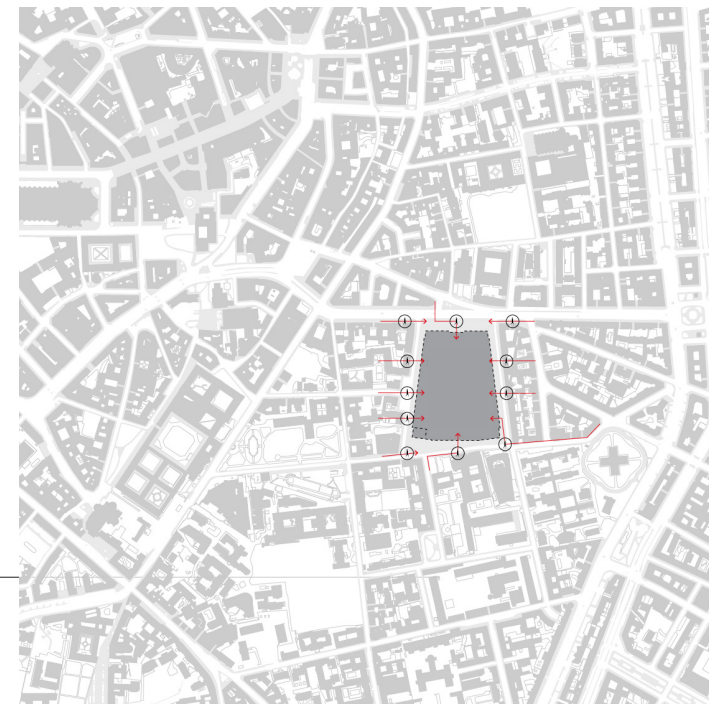

Pedestrian

ACCESS IN DETAIL

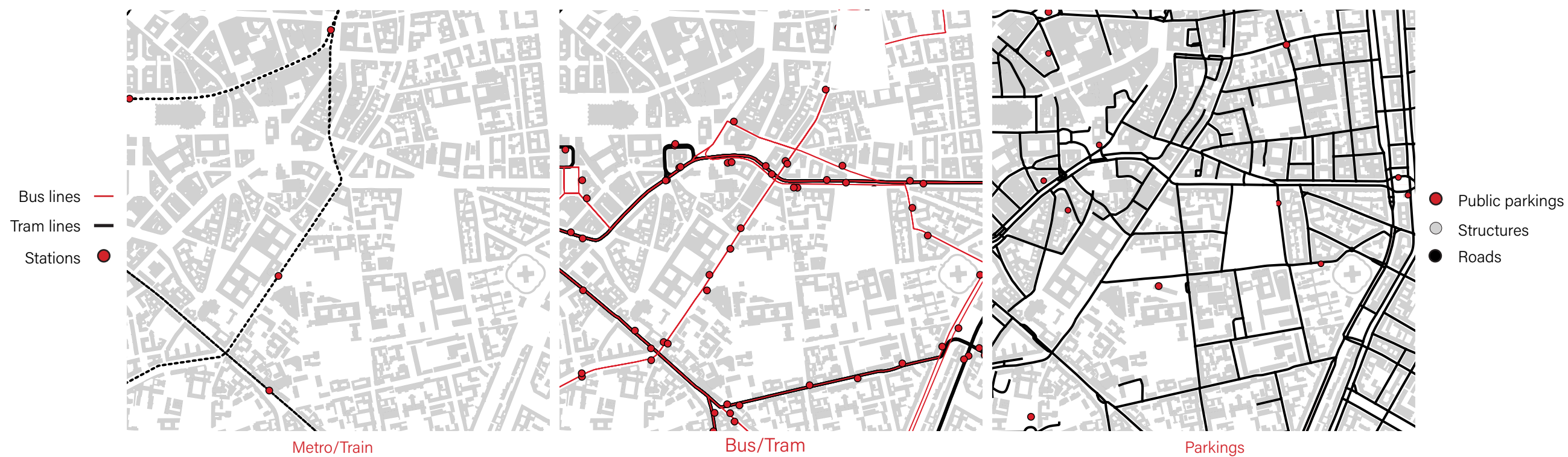

STATIONARY THRESHOLDS

EXISTING URBAN SITUATION

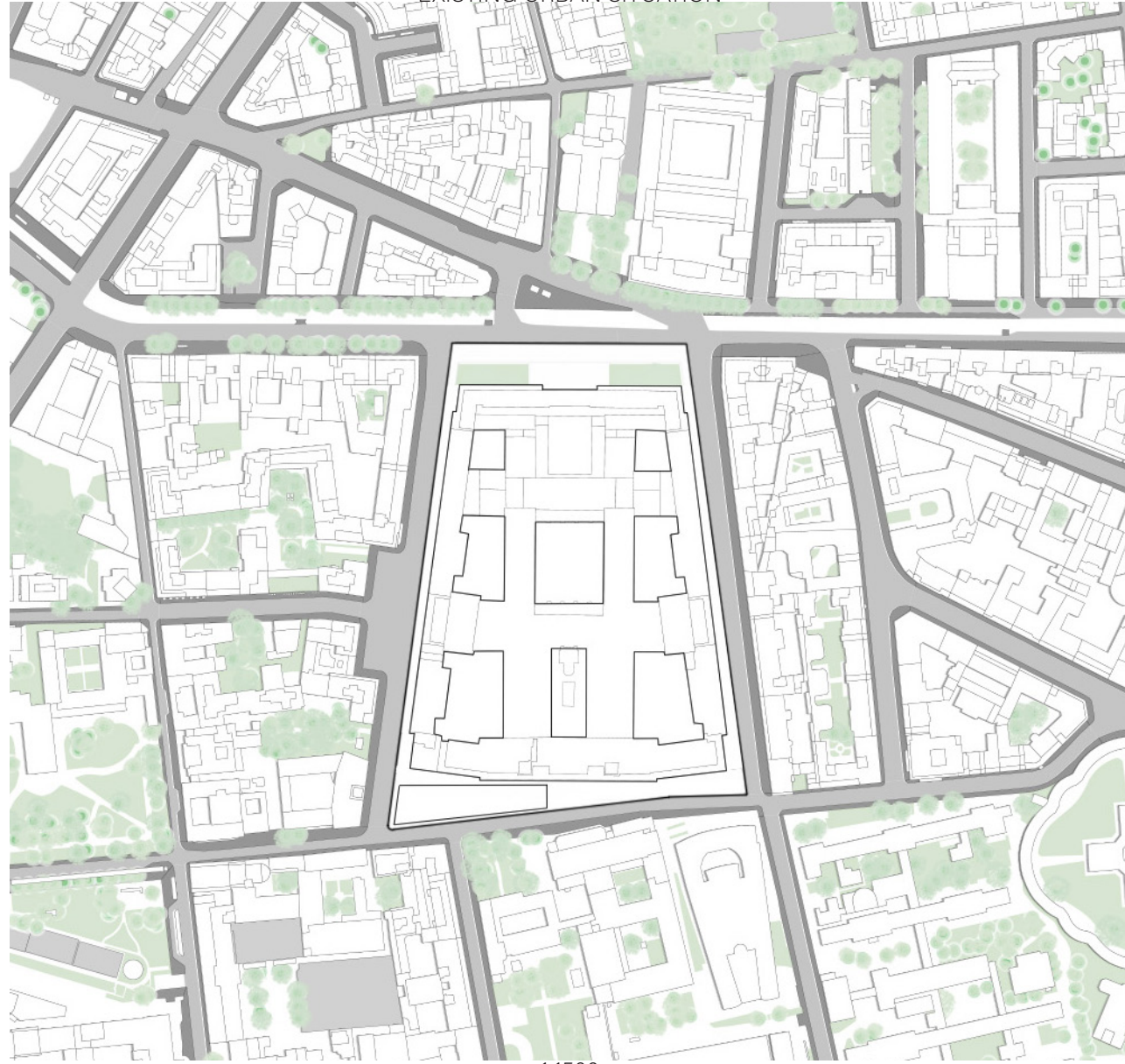

1:1500



SITE DEVELOPMENT

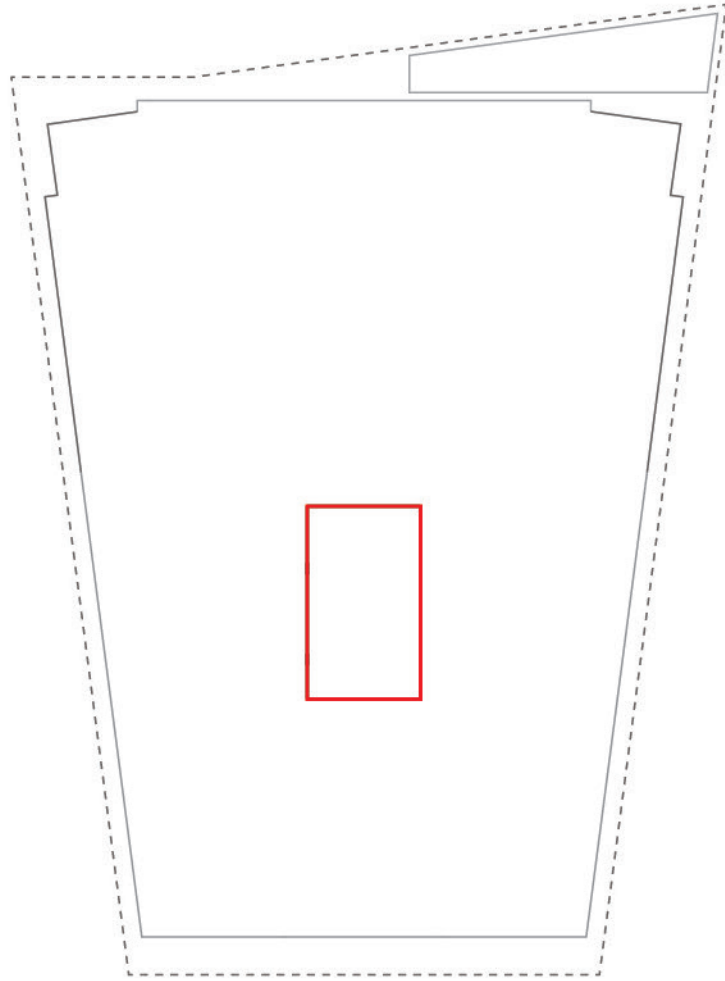

EXISTING

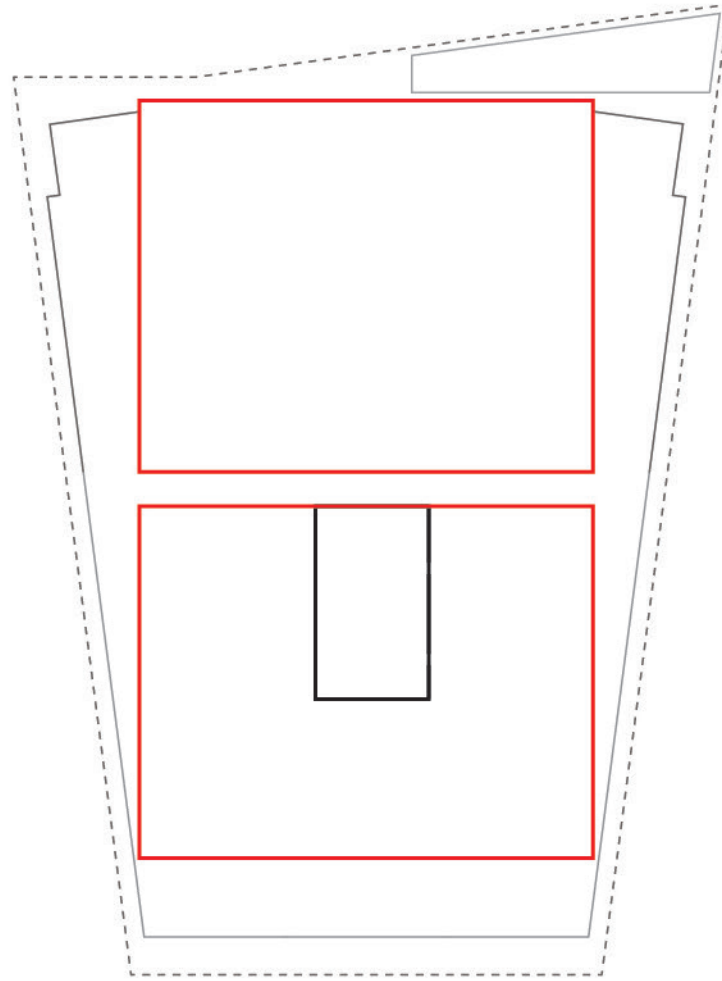

PIAZZA/BUILDING

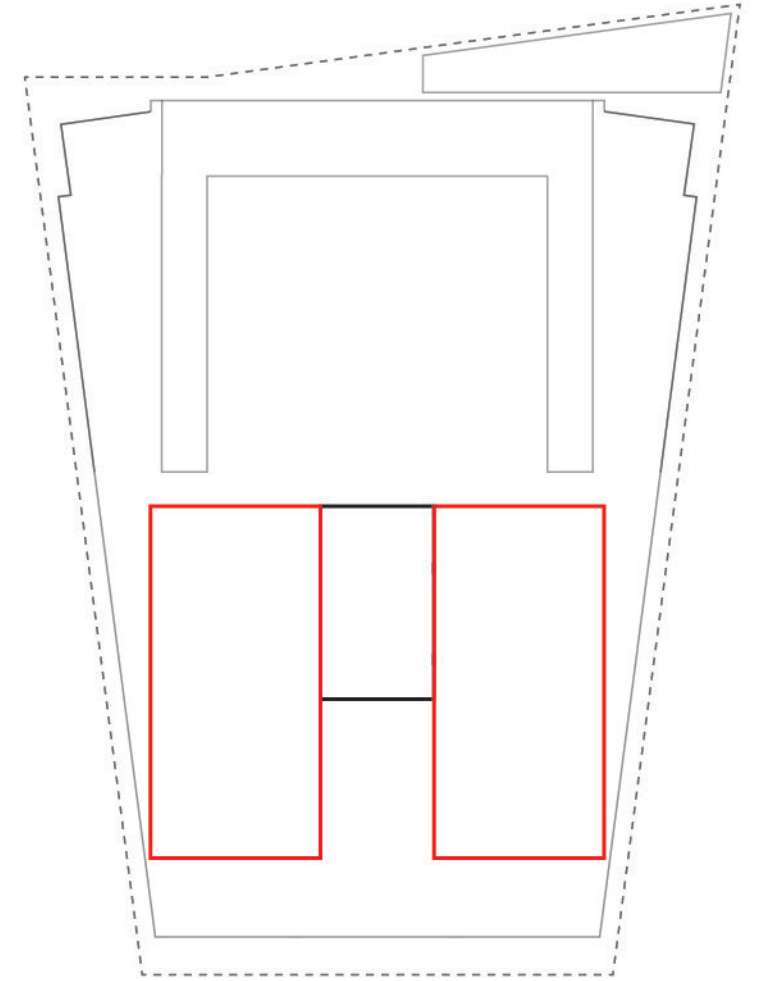

CIVIL/CRIMINAL

SITE DEVELOPMENT

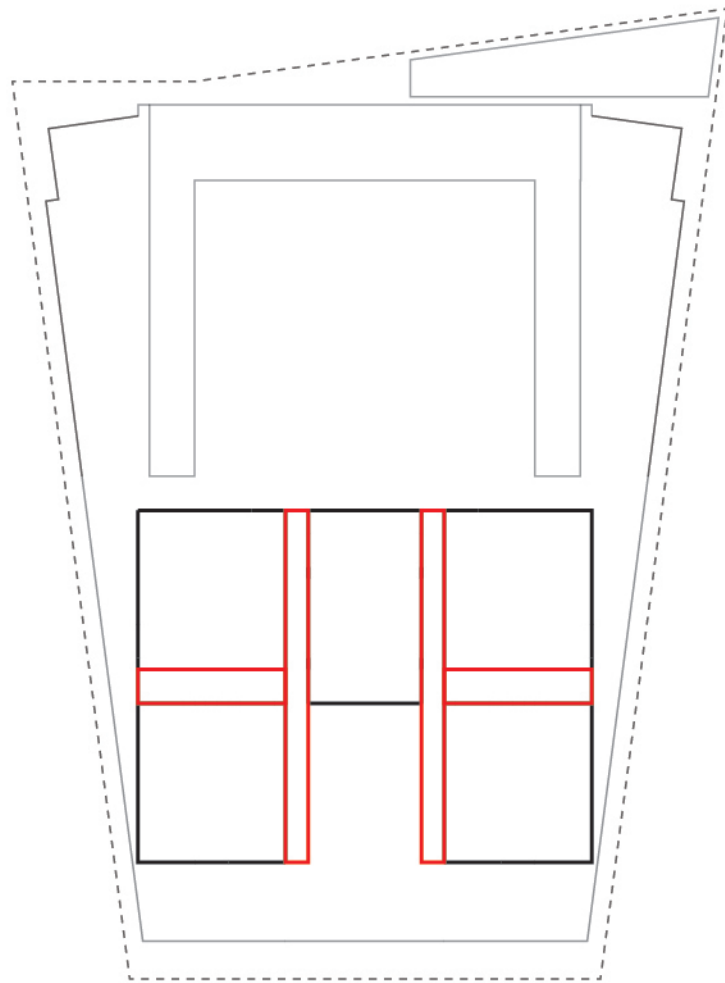

DIVIDERS

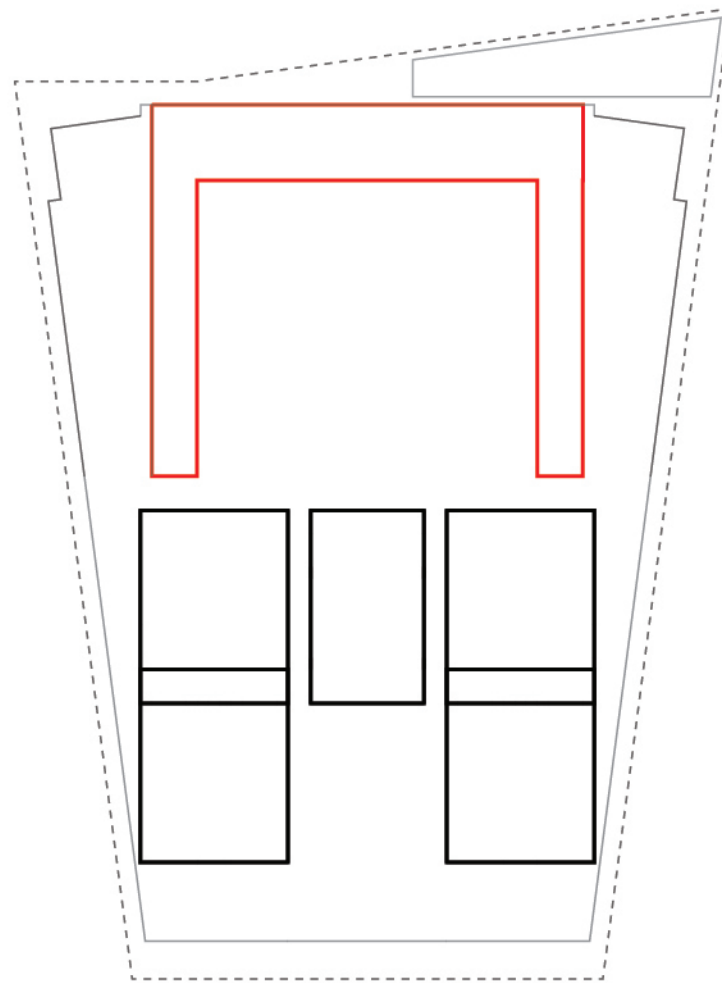

FOLLOWING PIAZZA

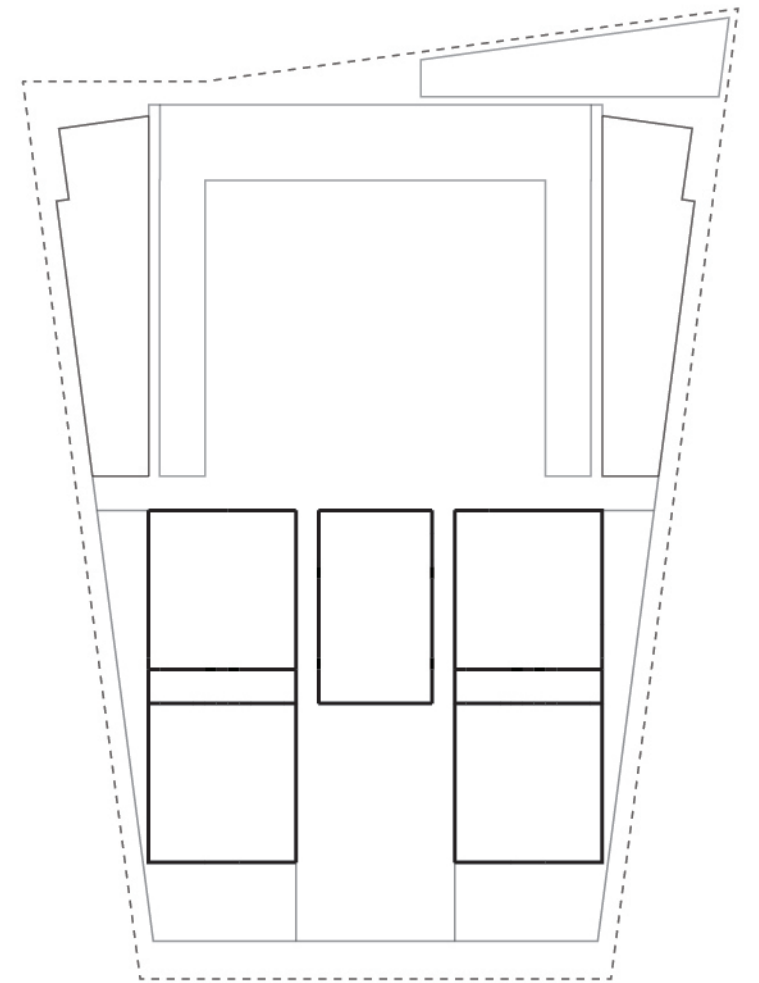

NEW DESIGN

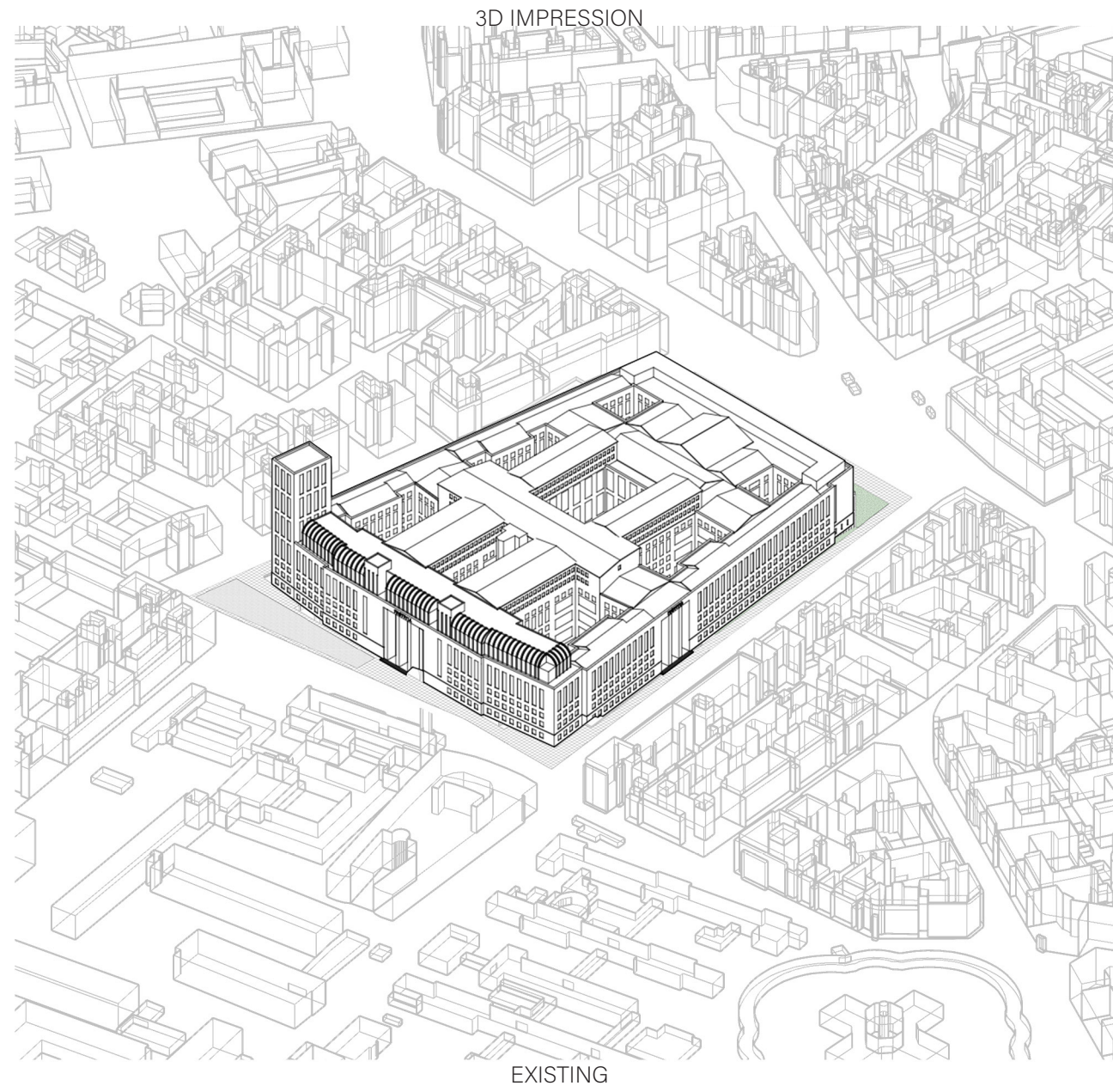

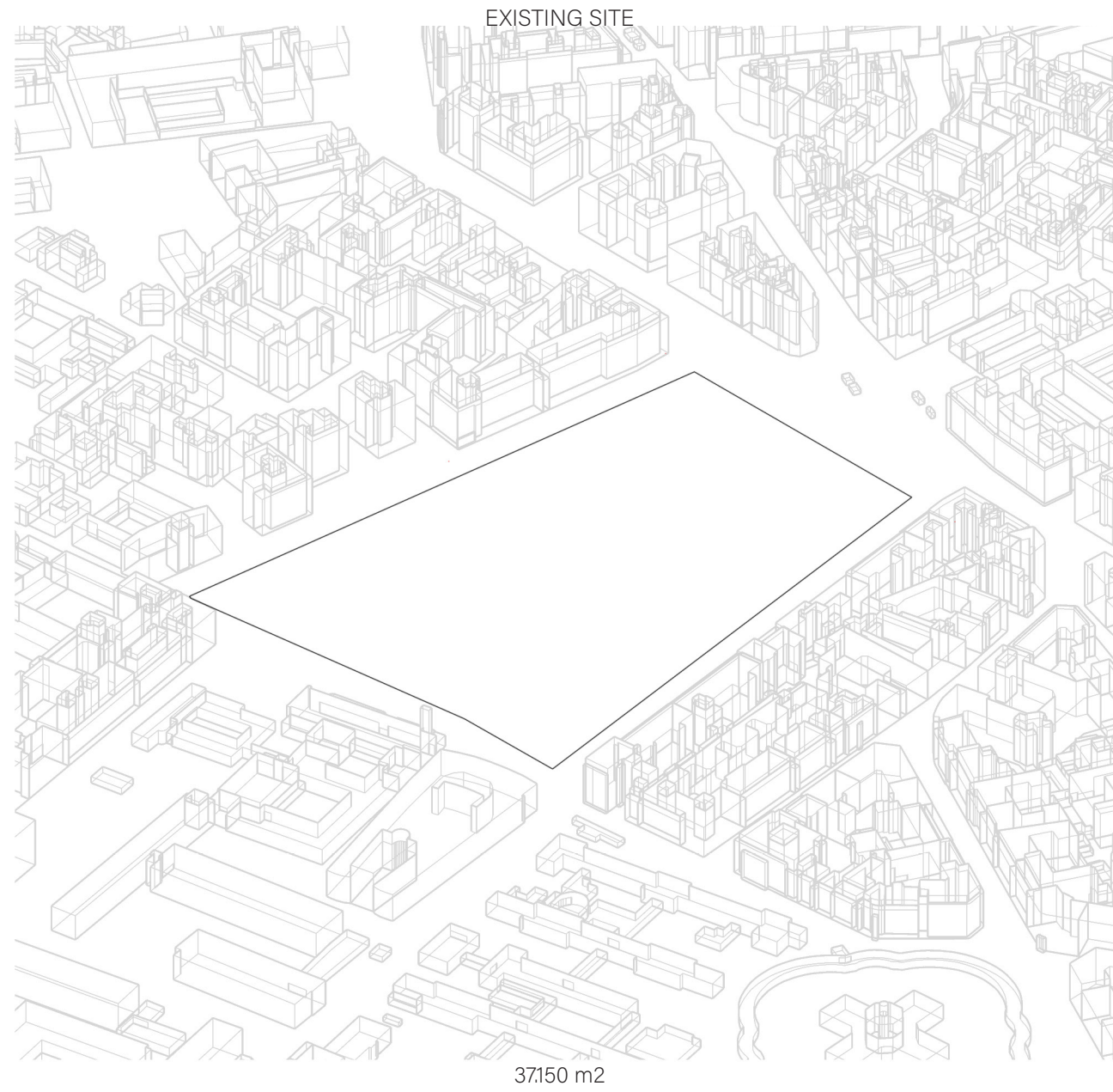

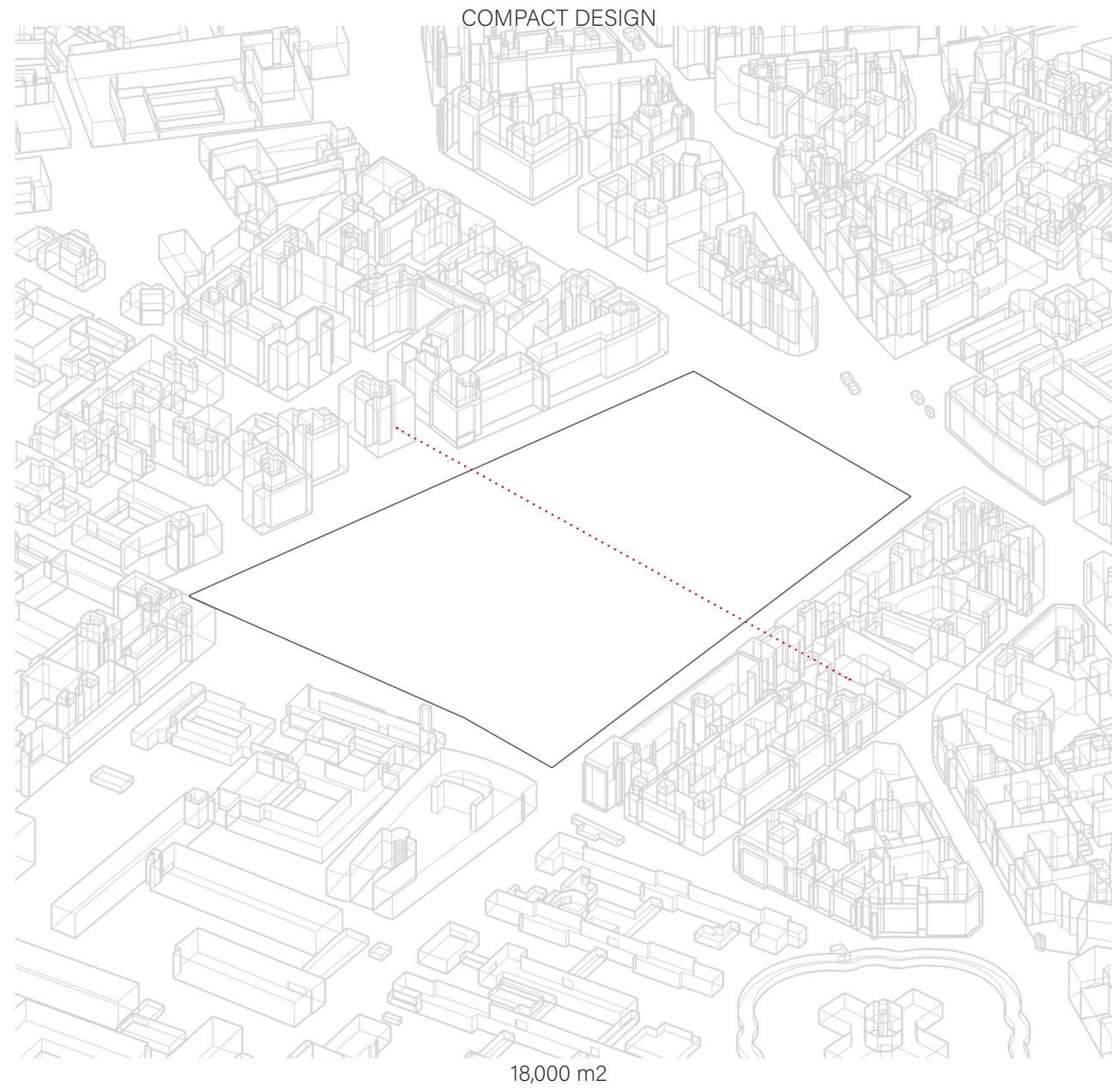

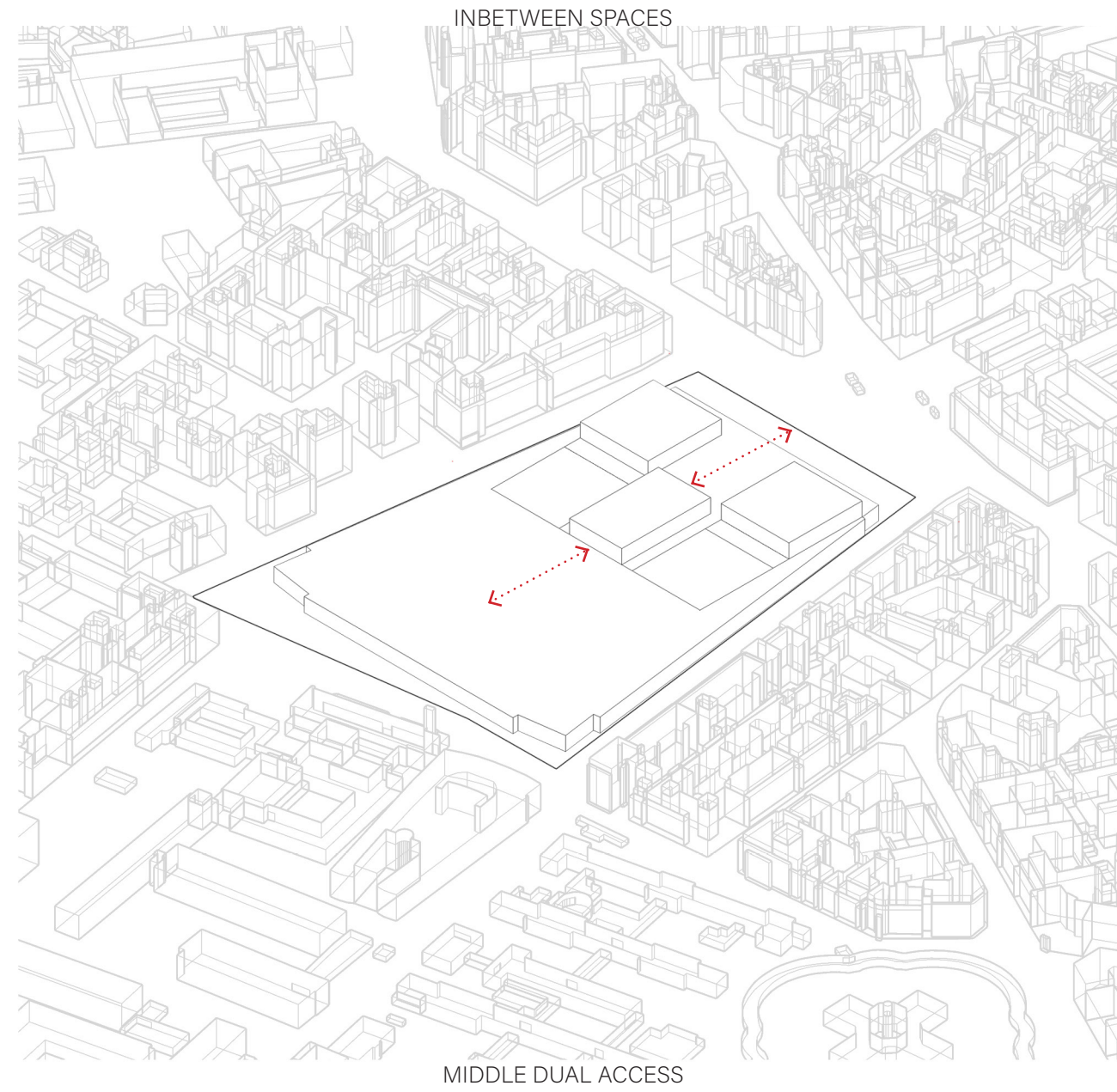

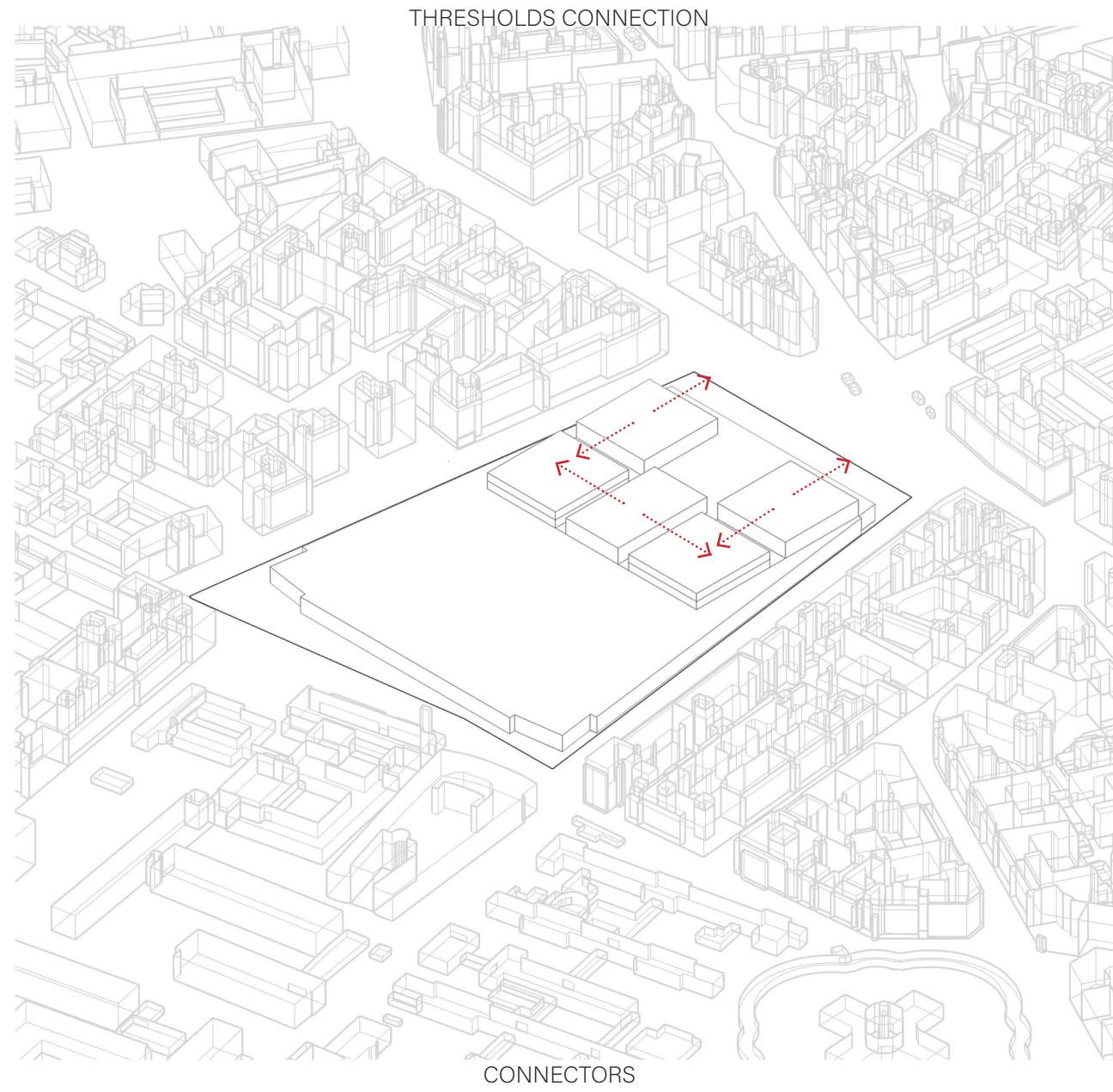

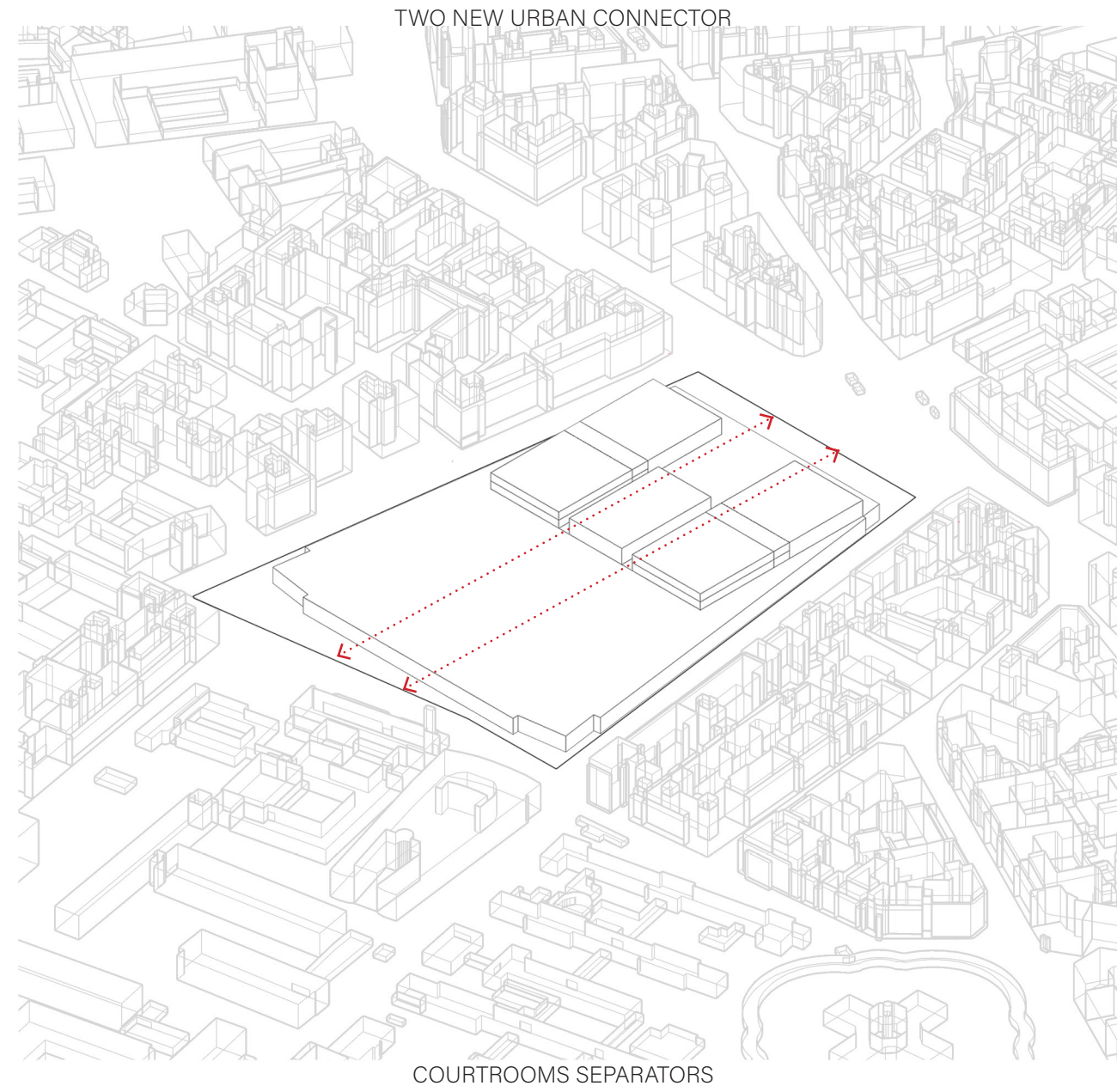

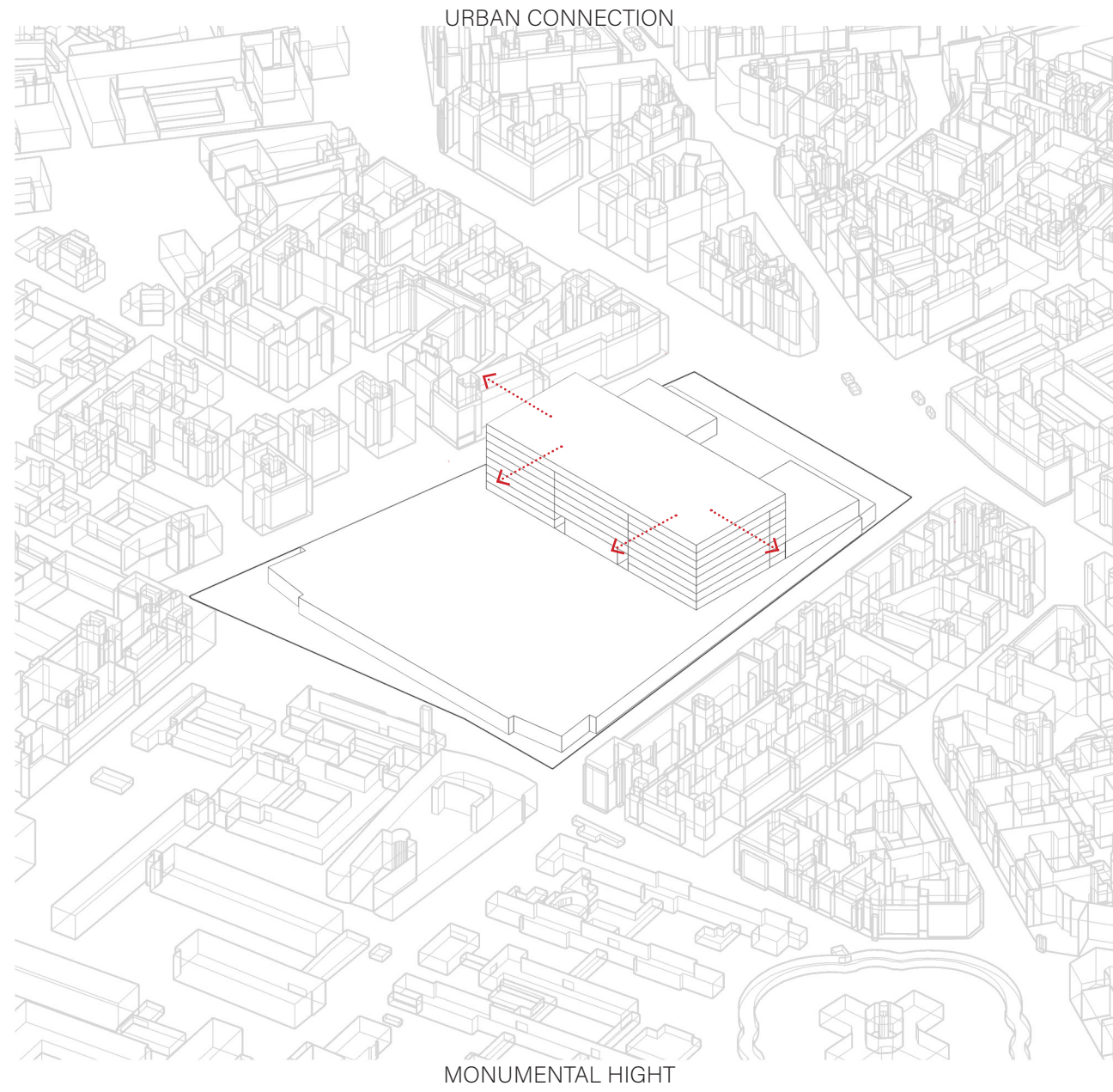

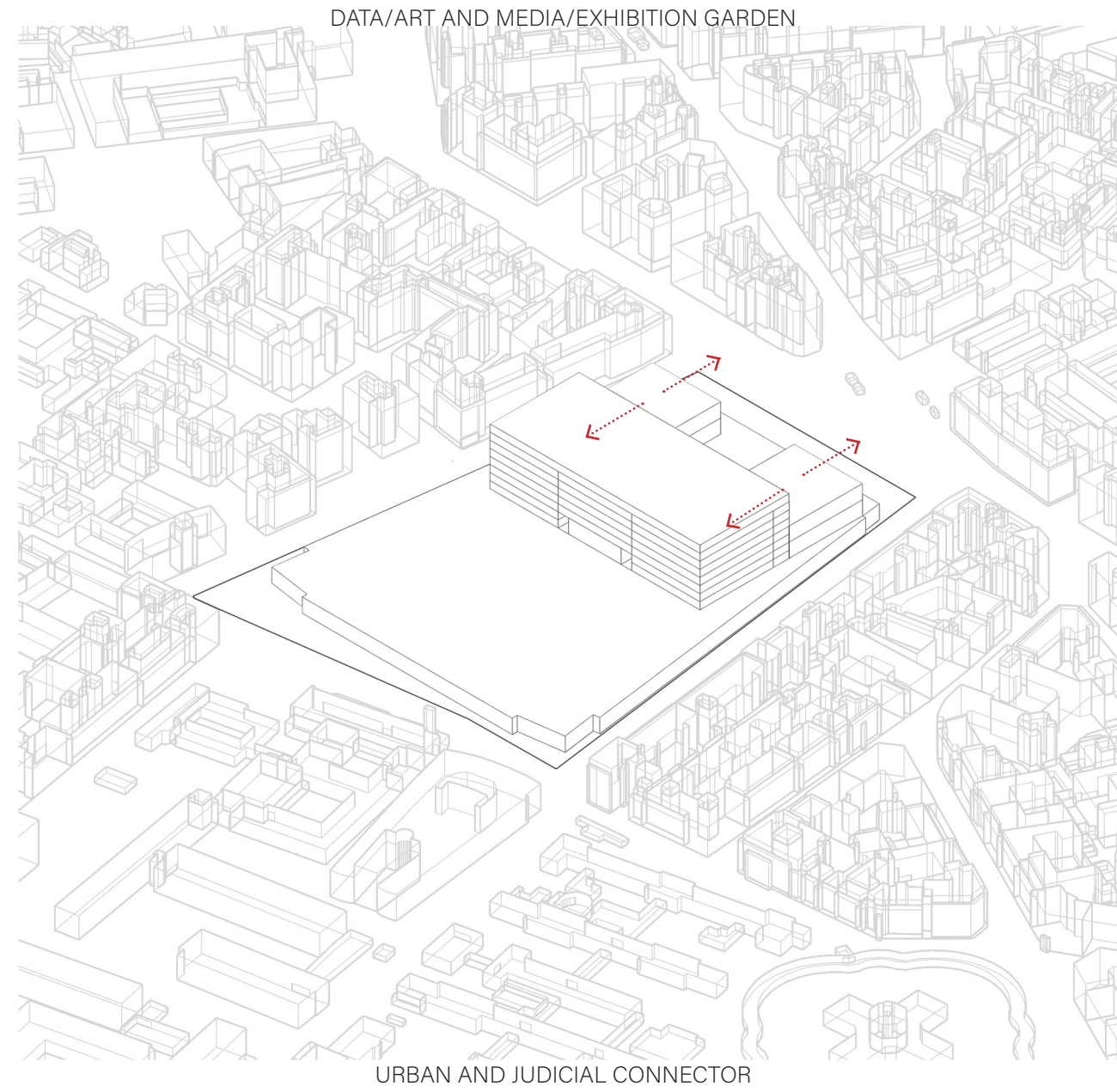

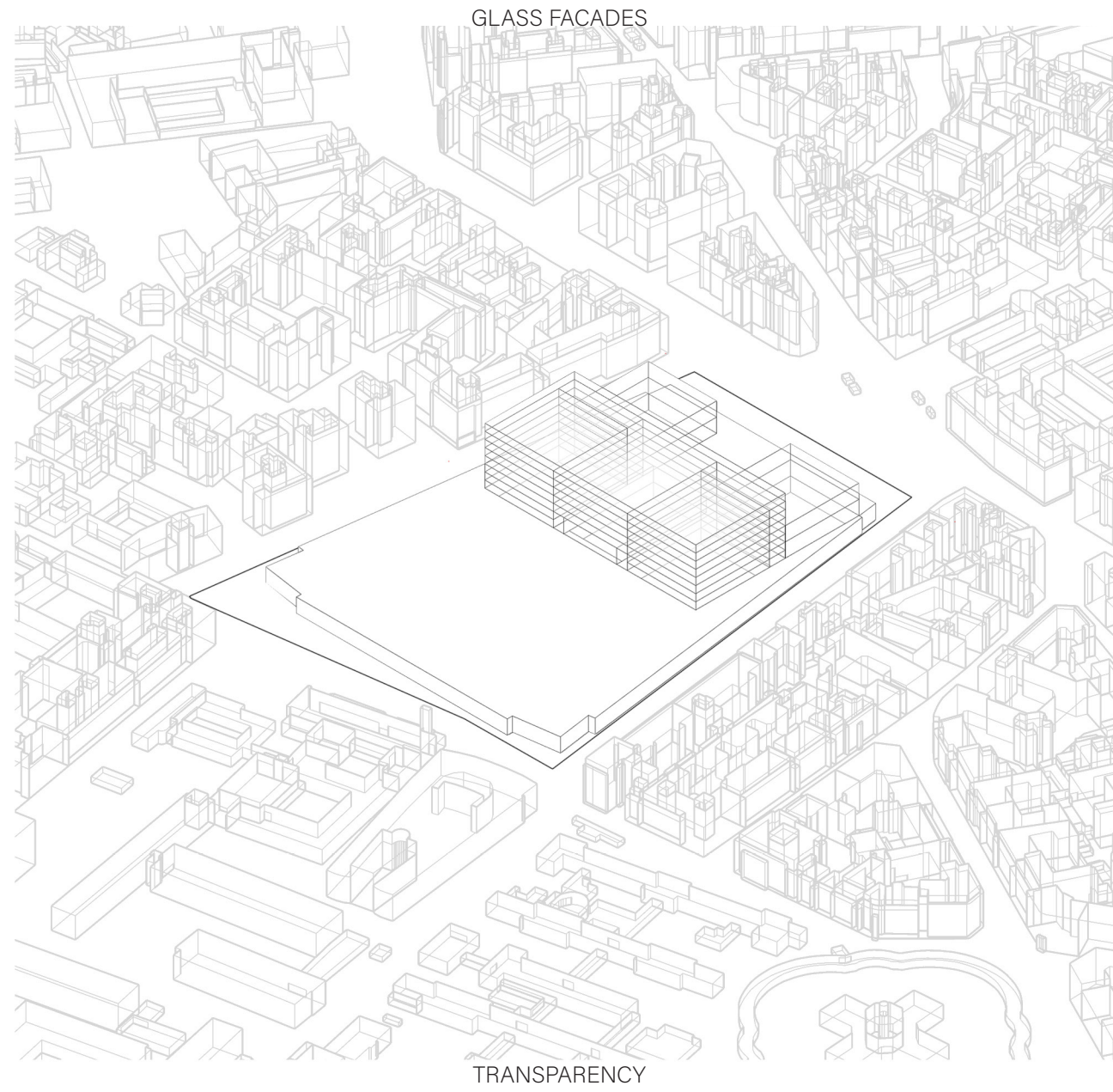

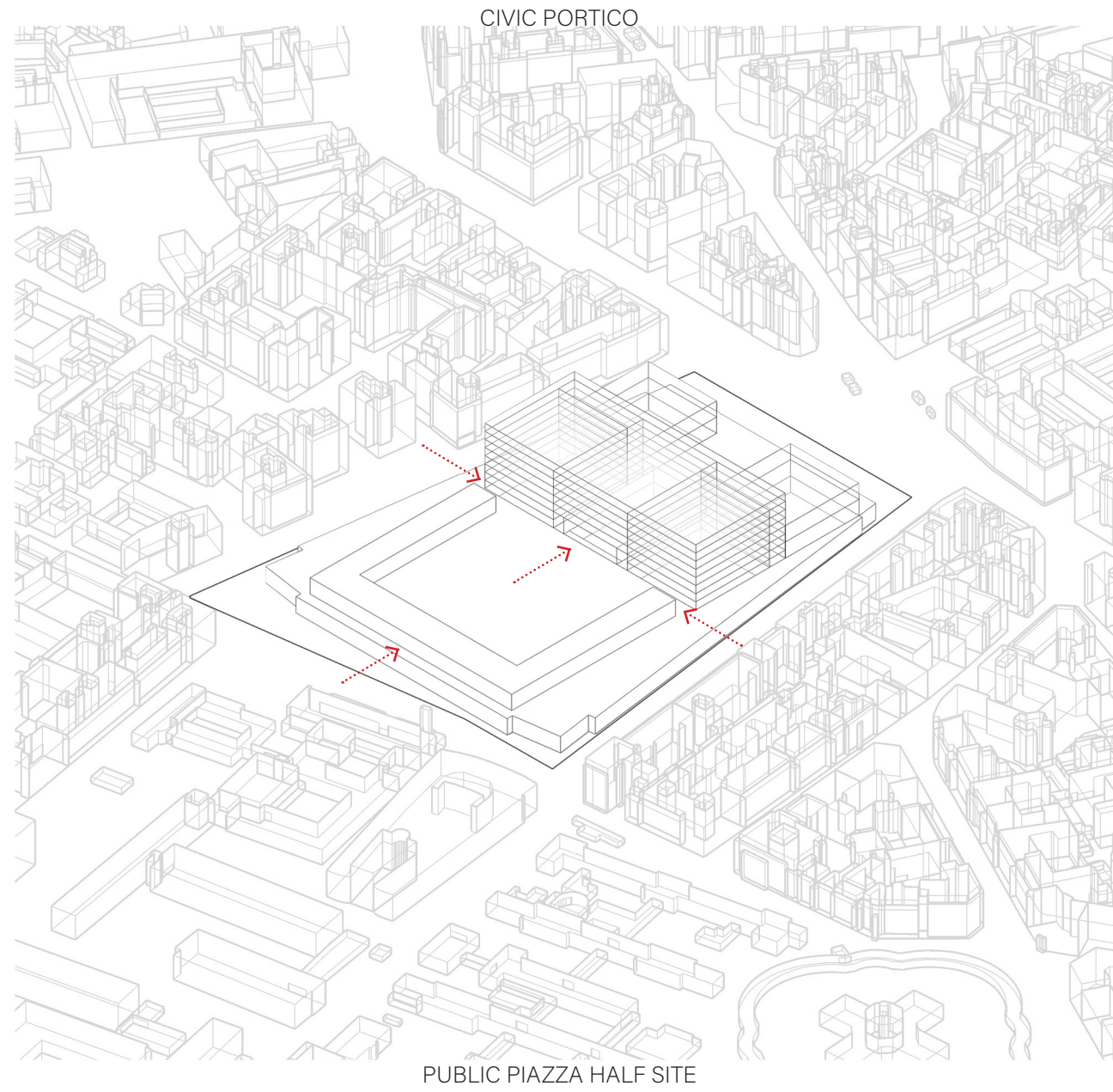

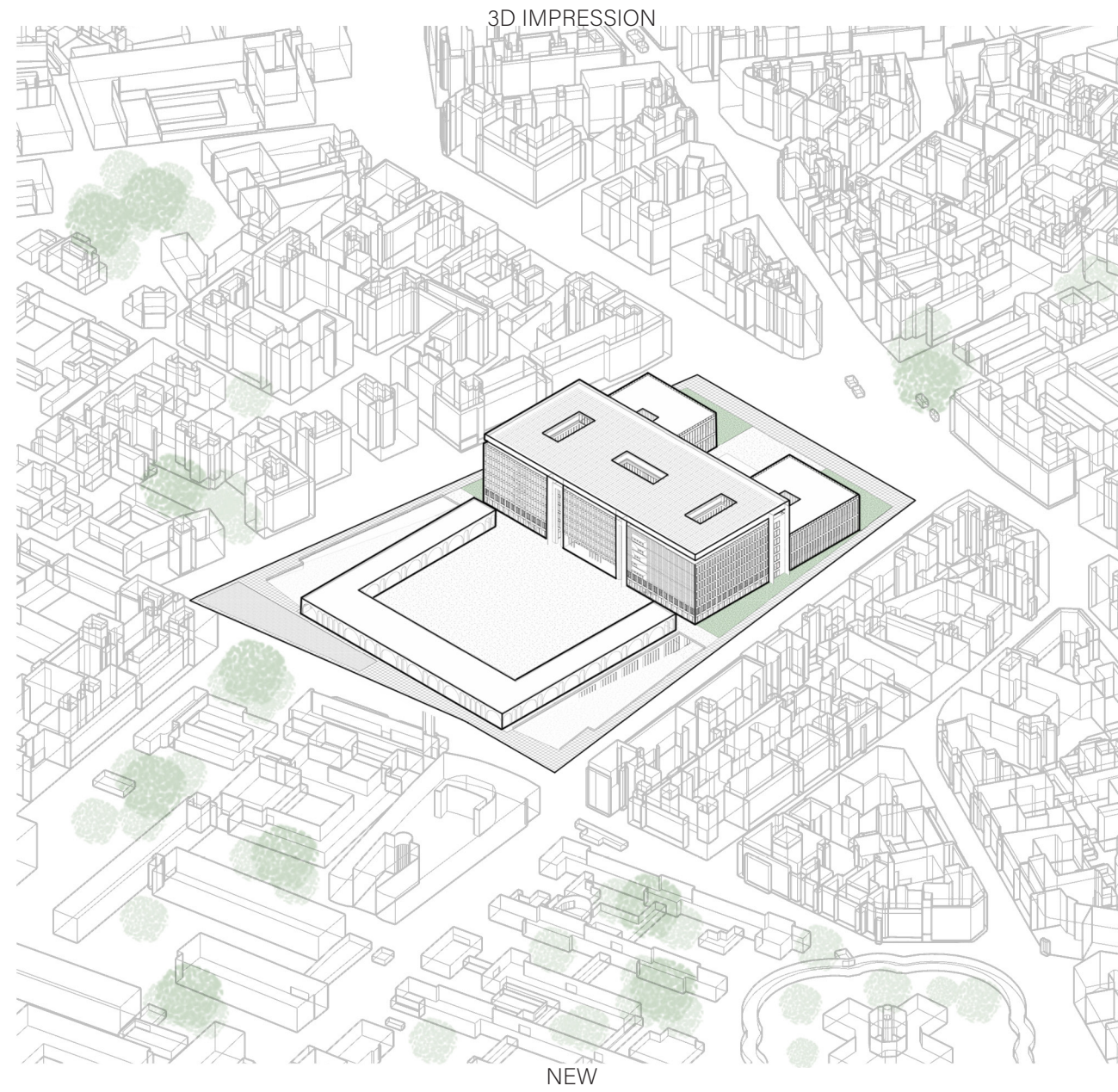

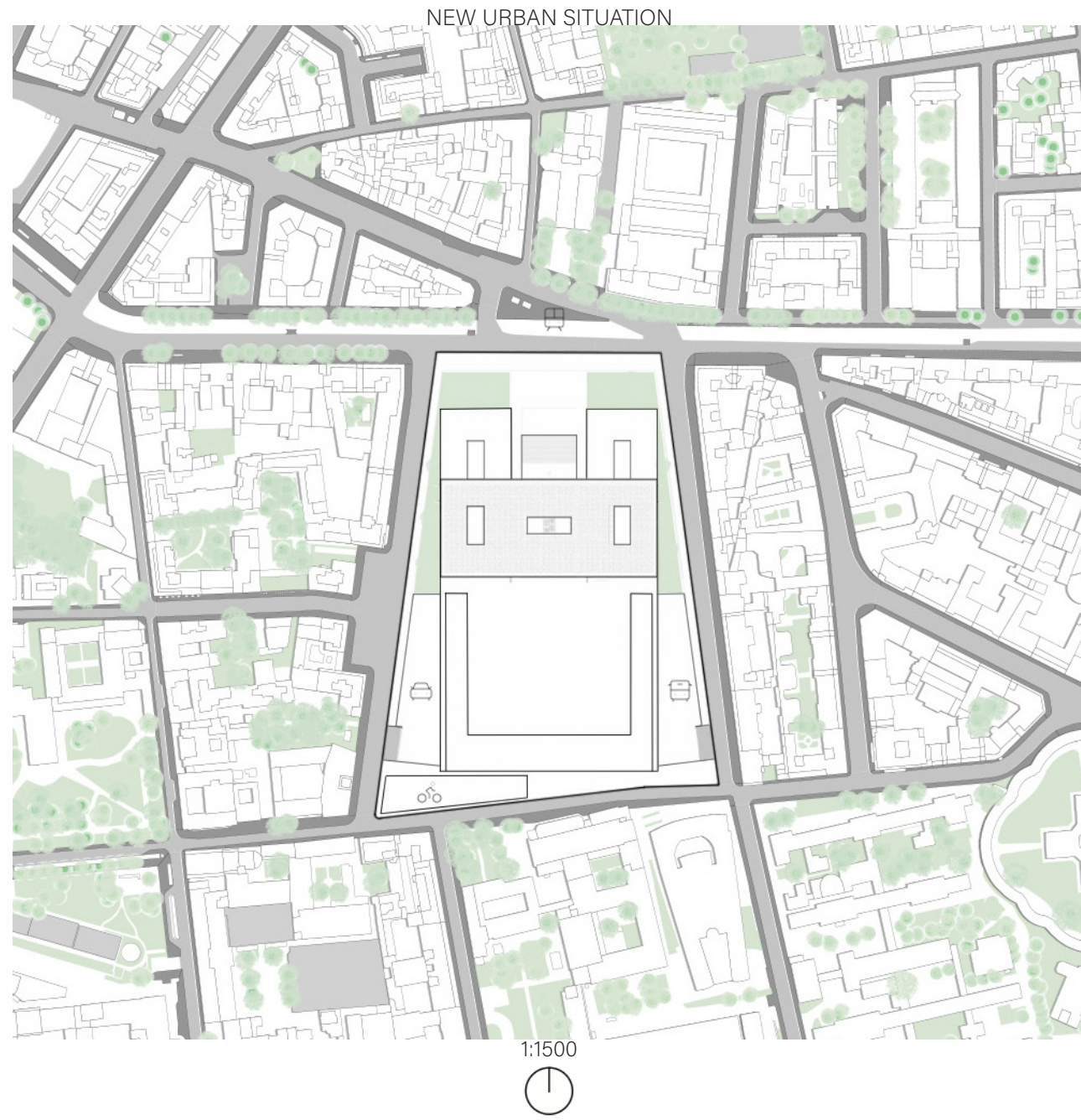

UNPREDICTABILITY

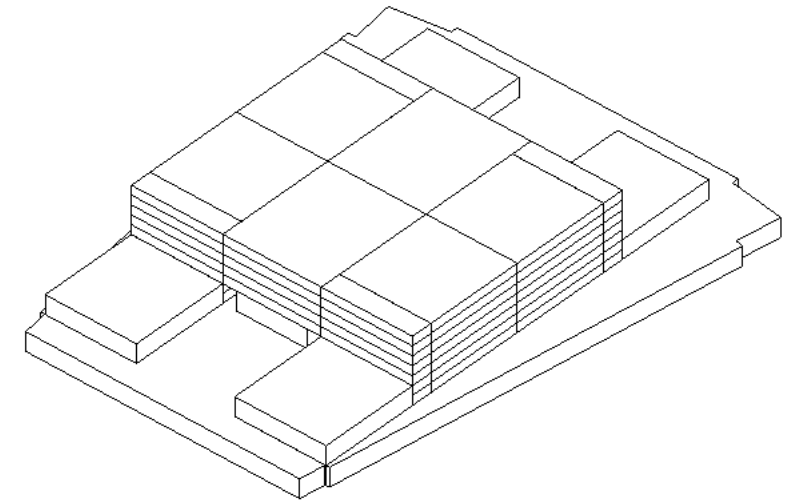
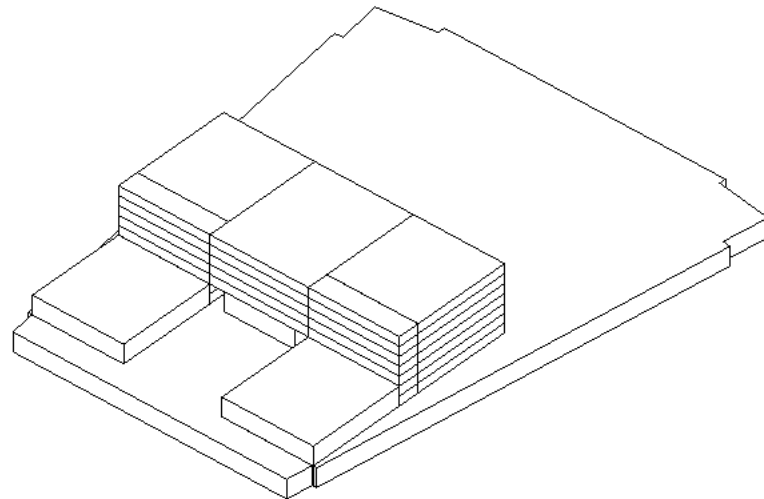
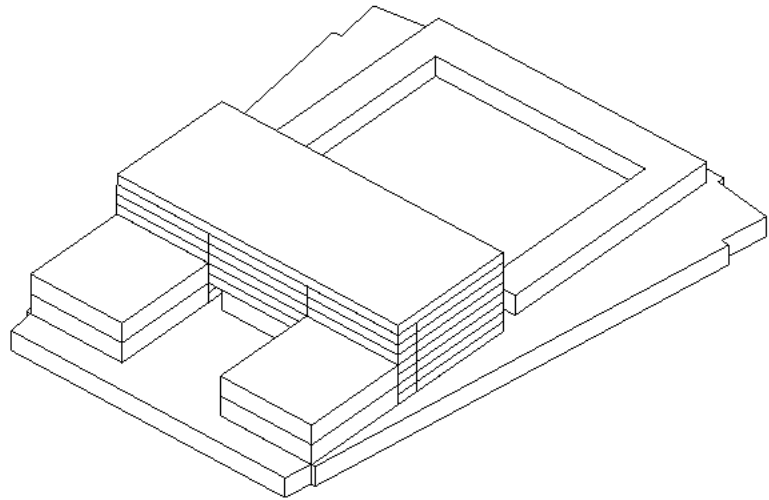

POSSIBLE FUTURE THRESHOLD

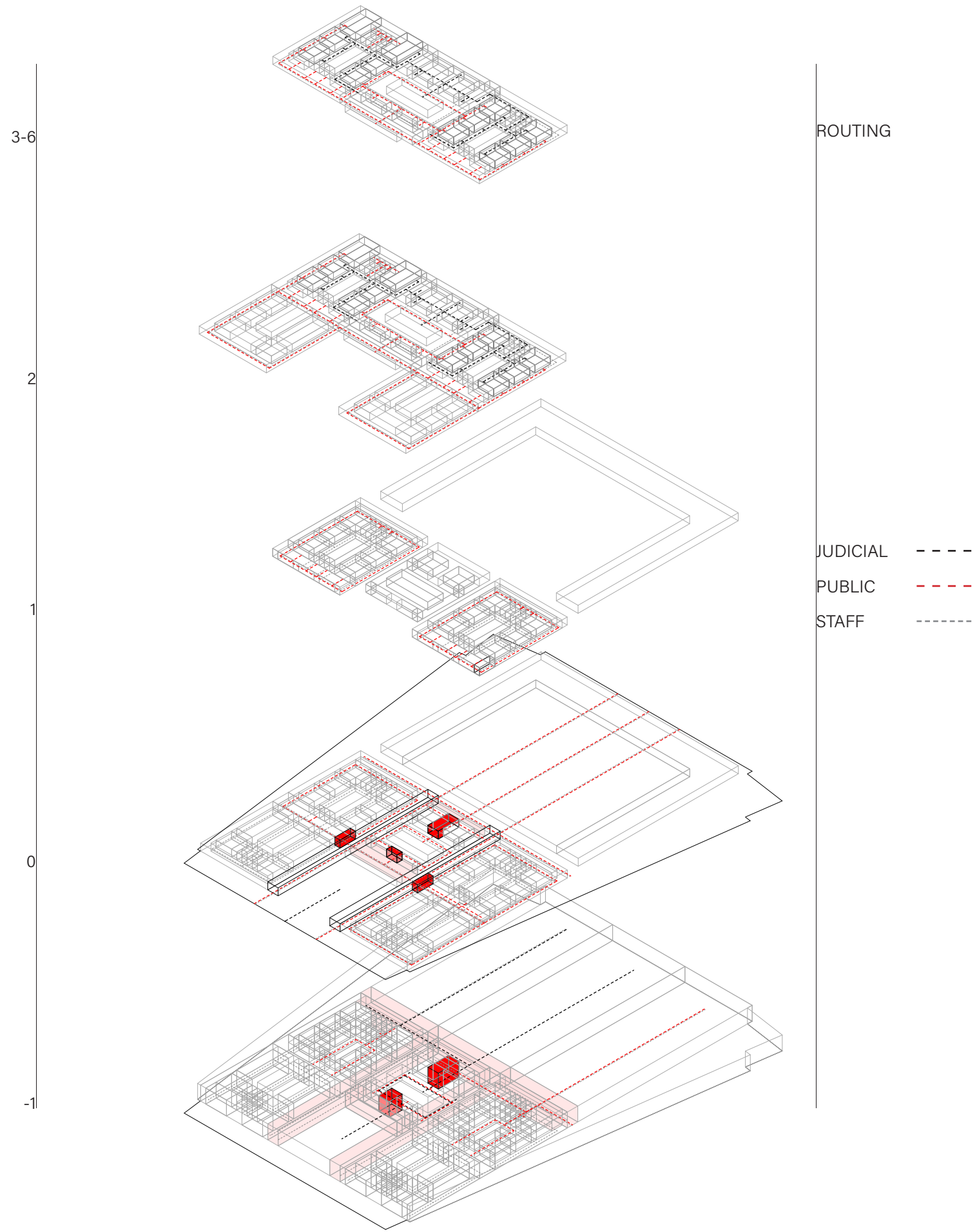

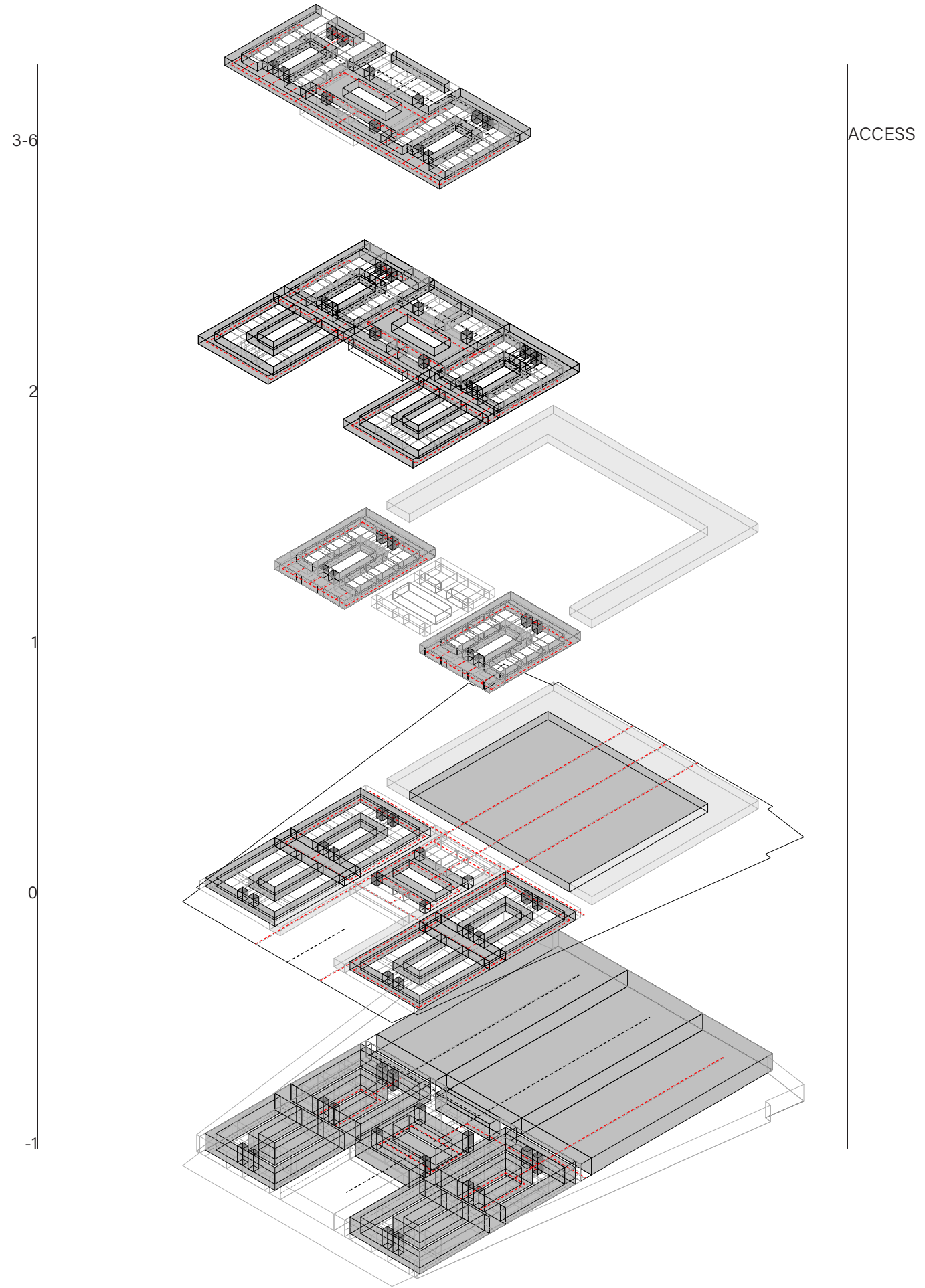

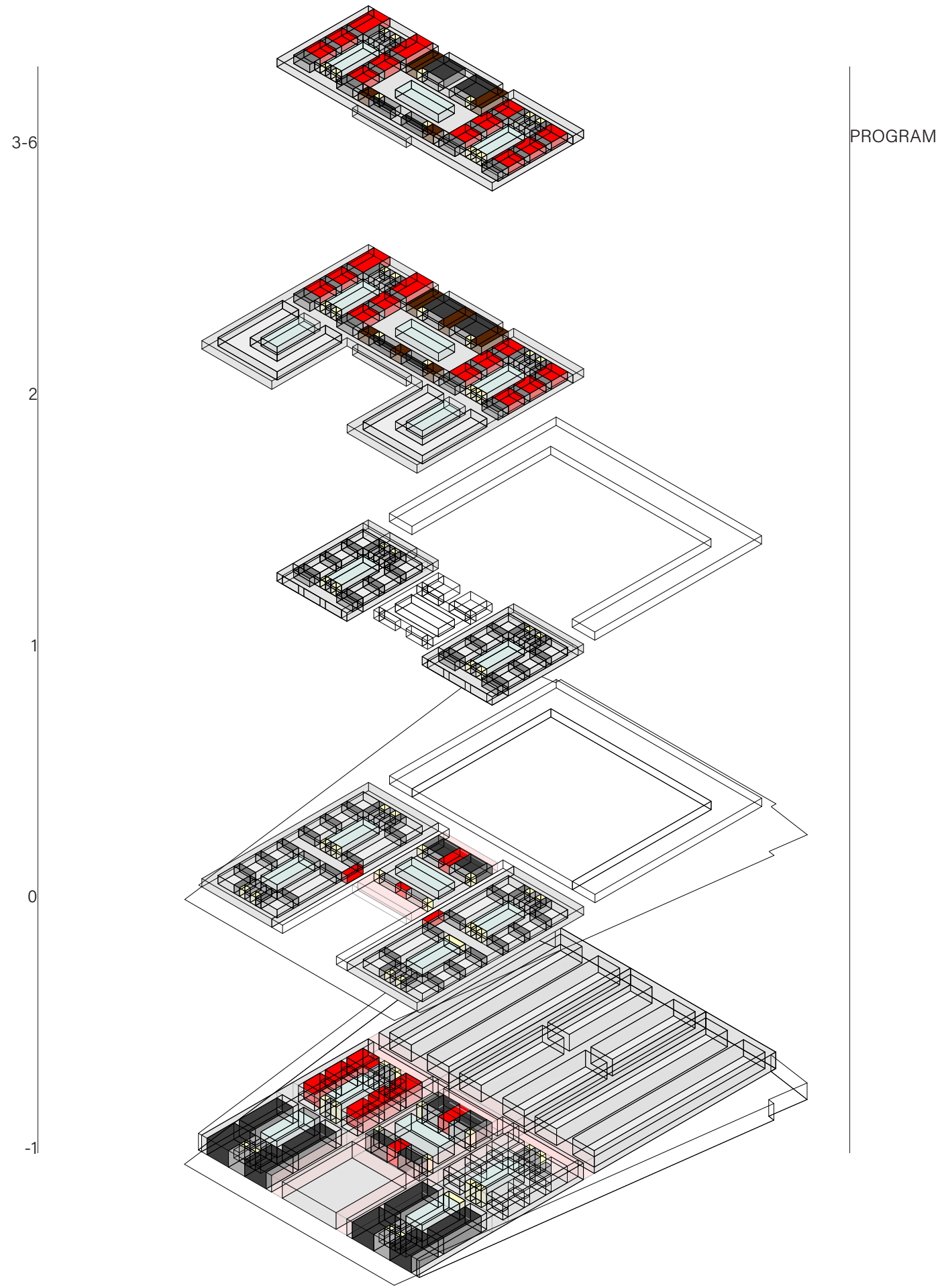

THRESHOLDS OF POWER

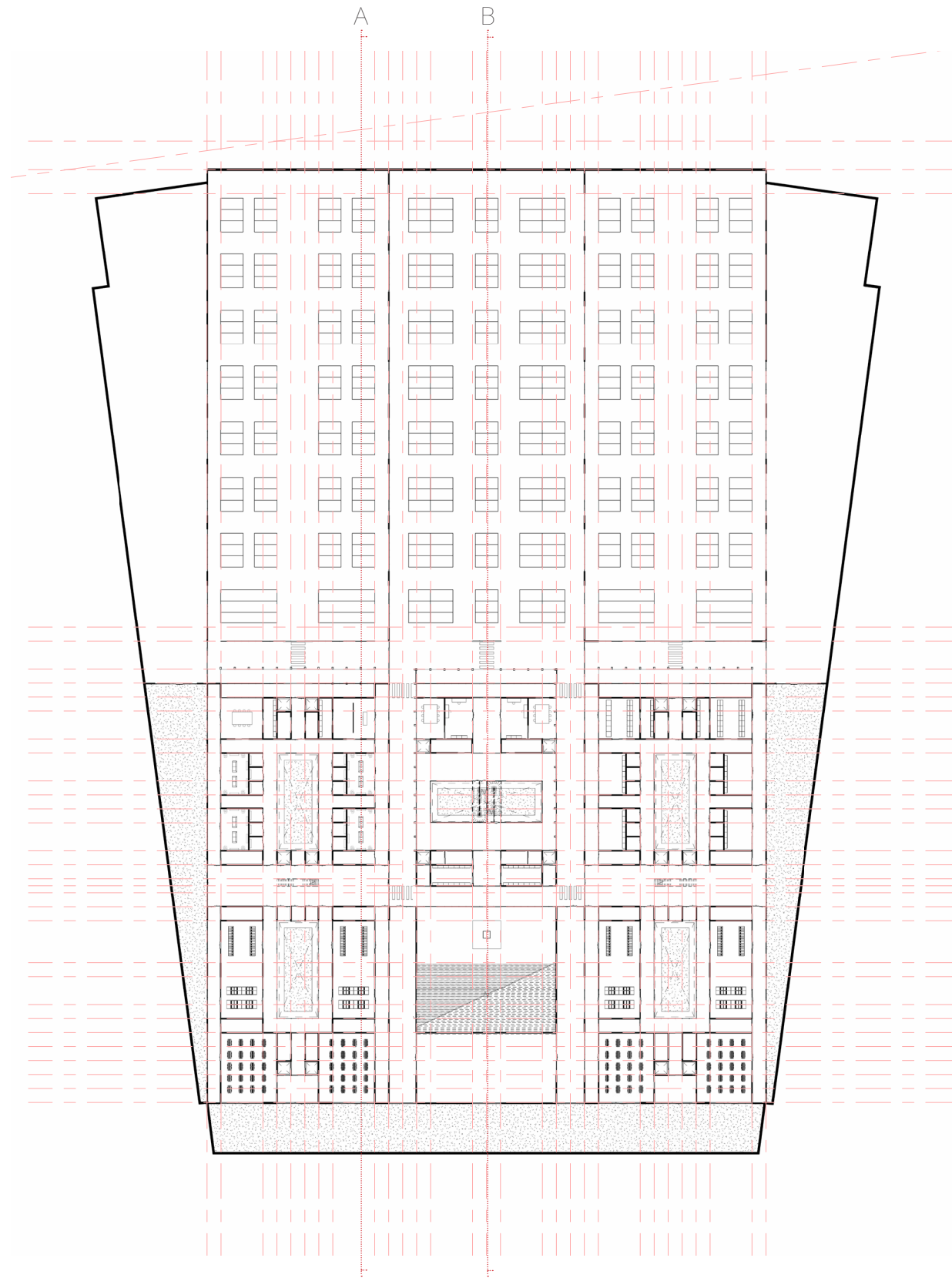
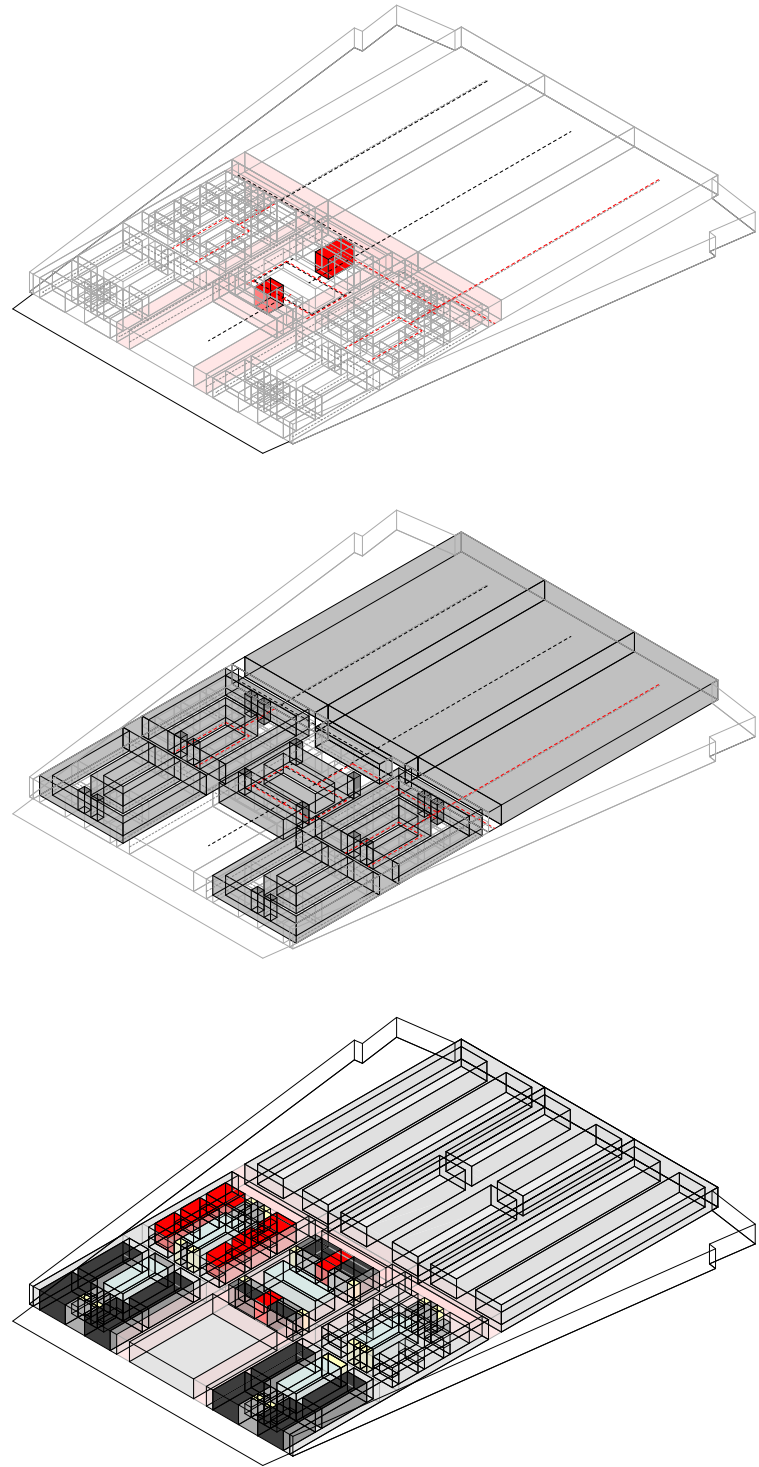

Custody
Hallway
Storage
Utilities
Parking



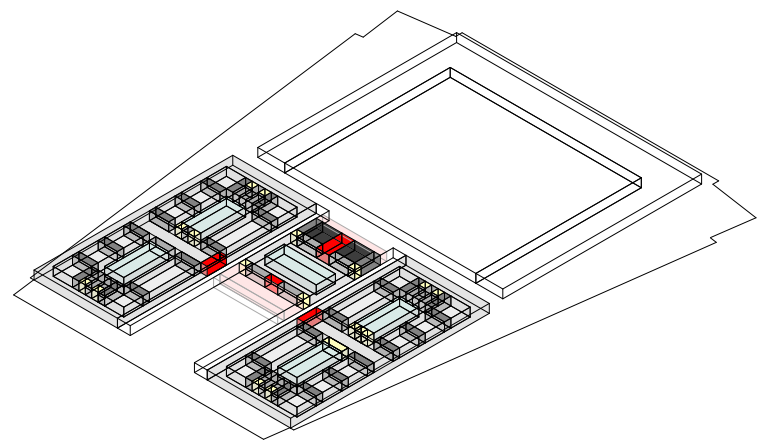
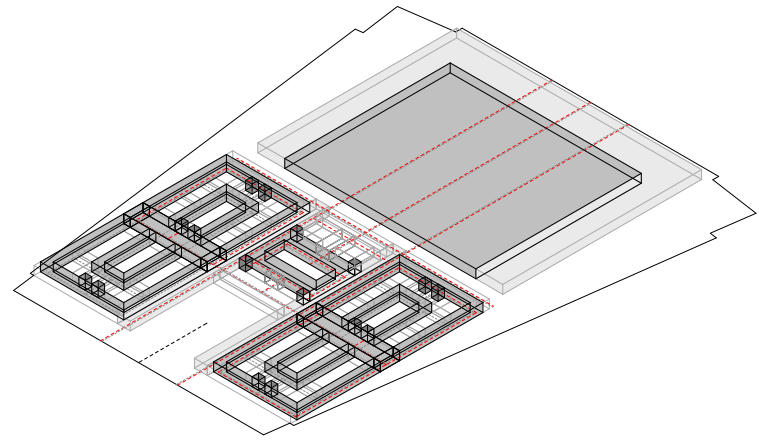
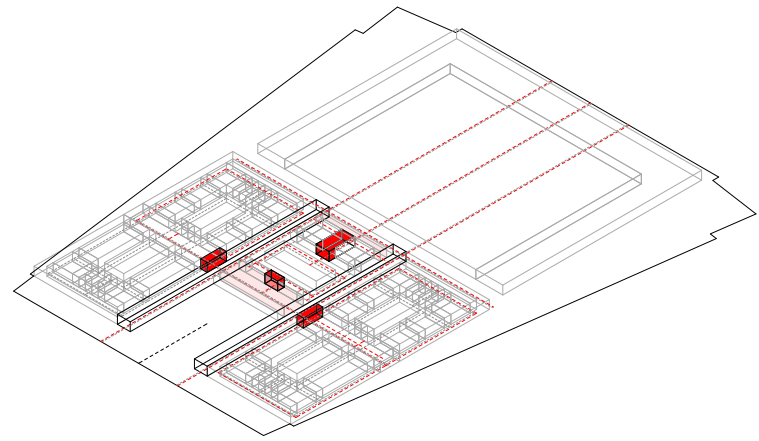

0

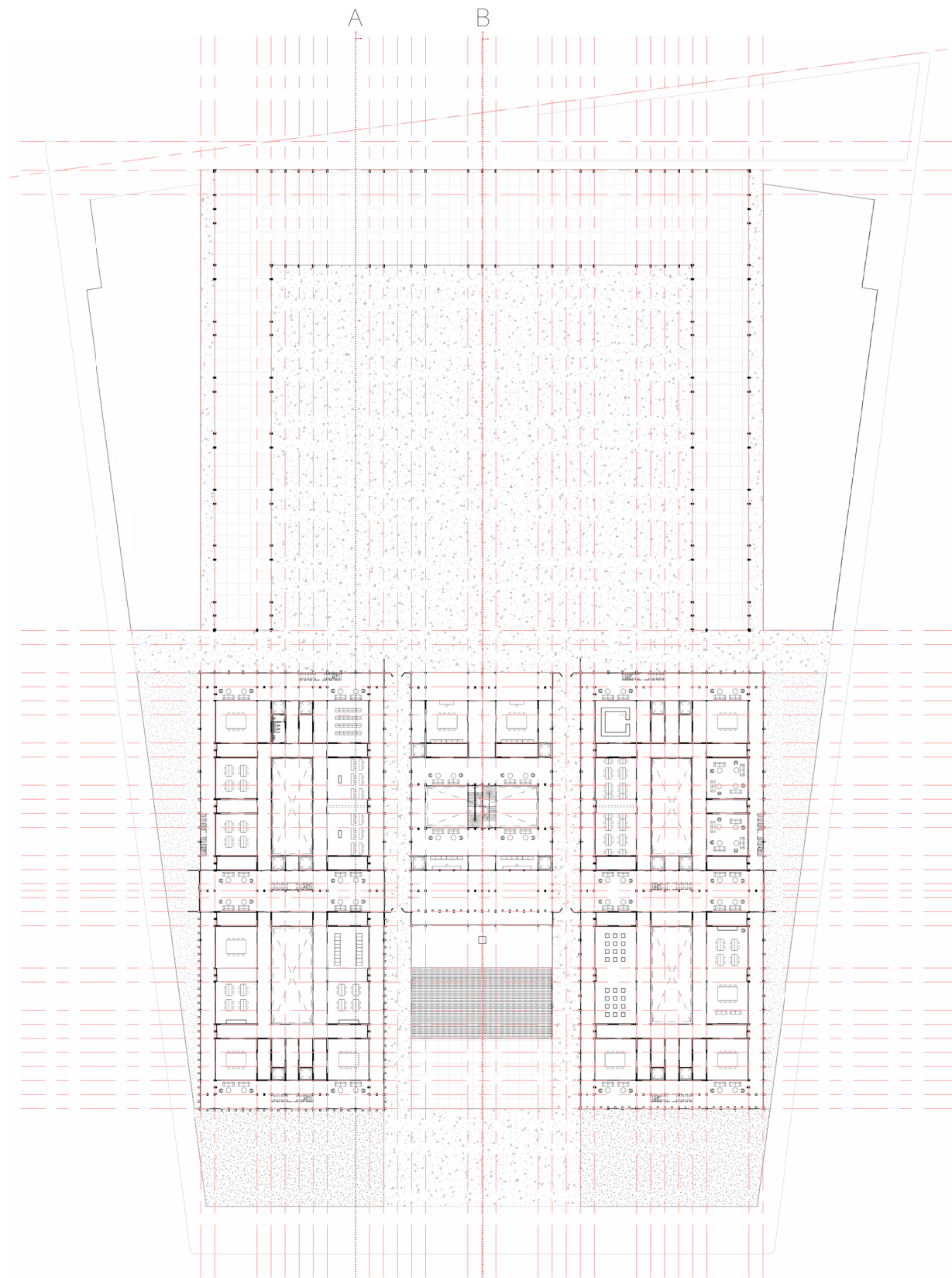

Piazza/Portico
Education Center
Civil Centre
Art/Media Center
Data Center
Hallway

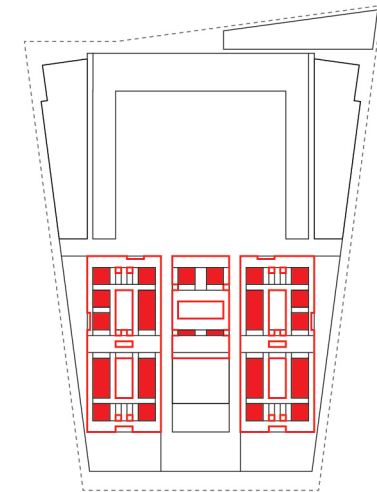
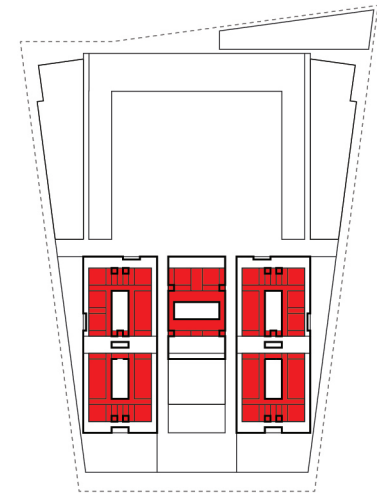
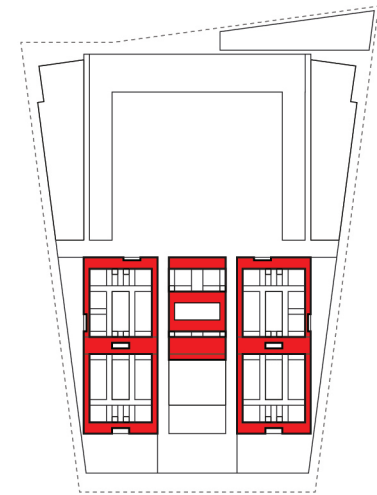

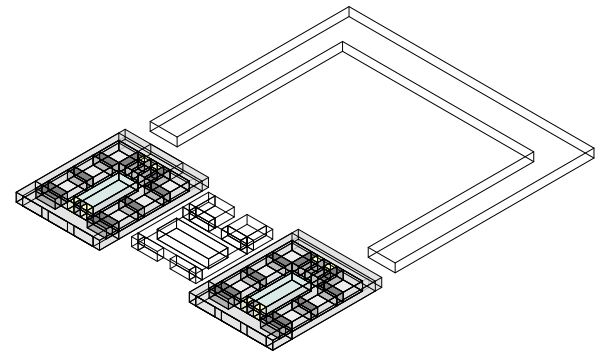
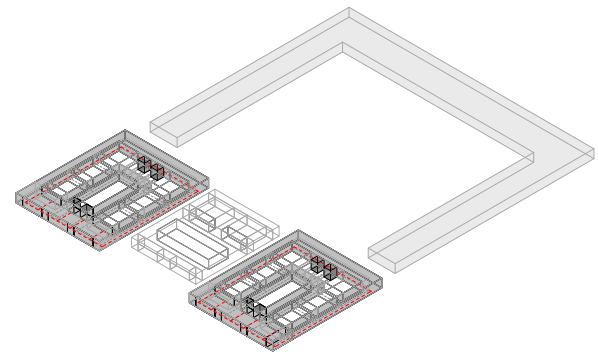
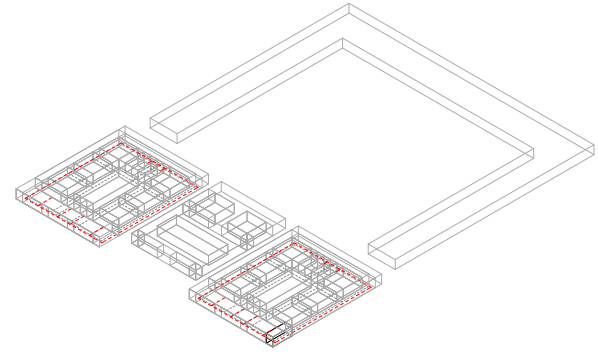

+1

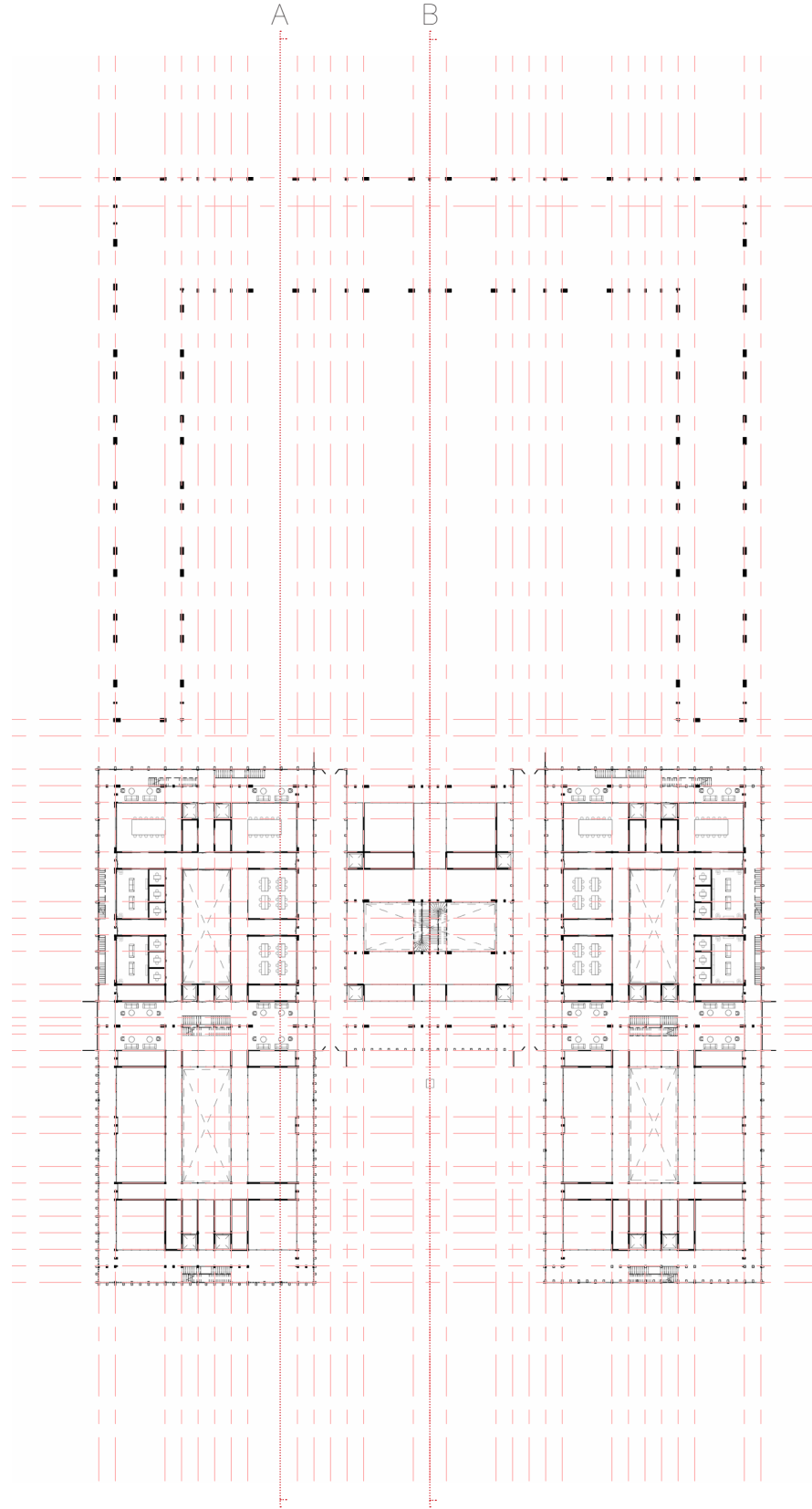

Broadcast Rooms
Conference Rooms
Prosecution Rooms
Hallway



+2

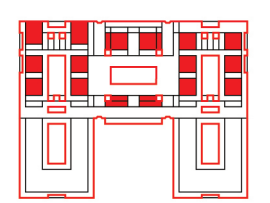
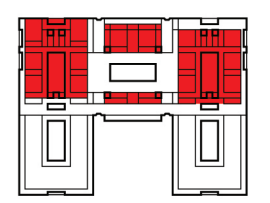
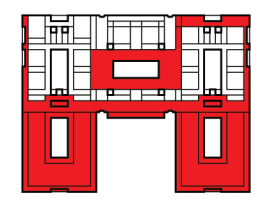
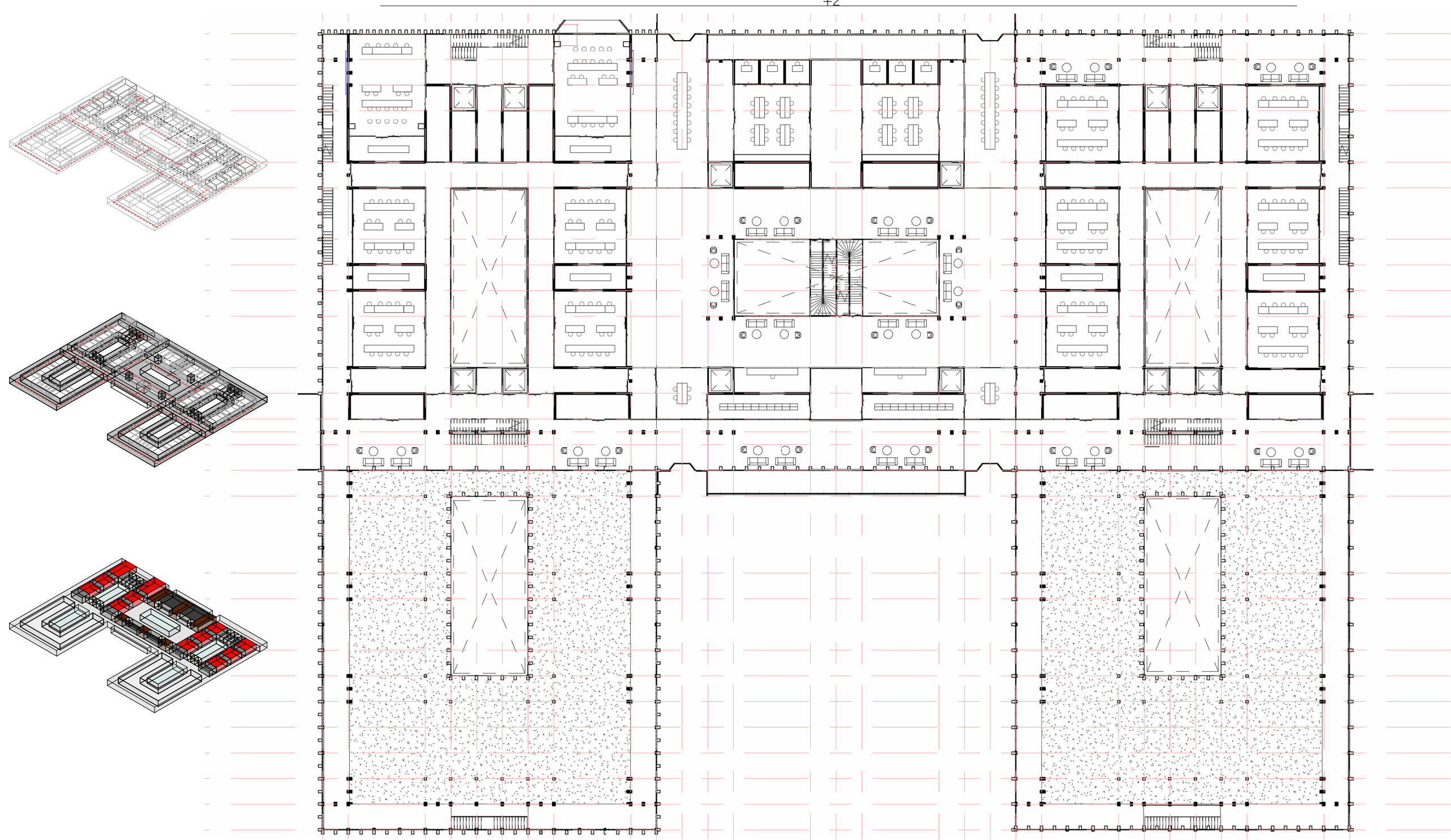

- Courtrooms
- Broadcast Rooms
- Evidence/Storage
- Offices
- Hallway
- Exhibition Garden



3

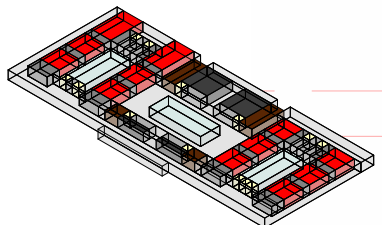
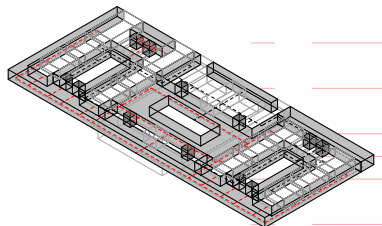
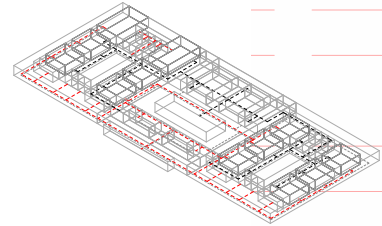
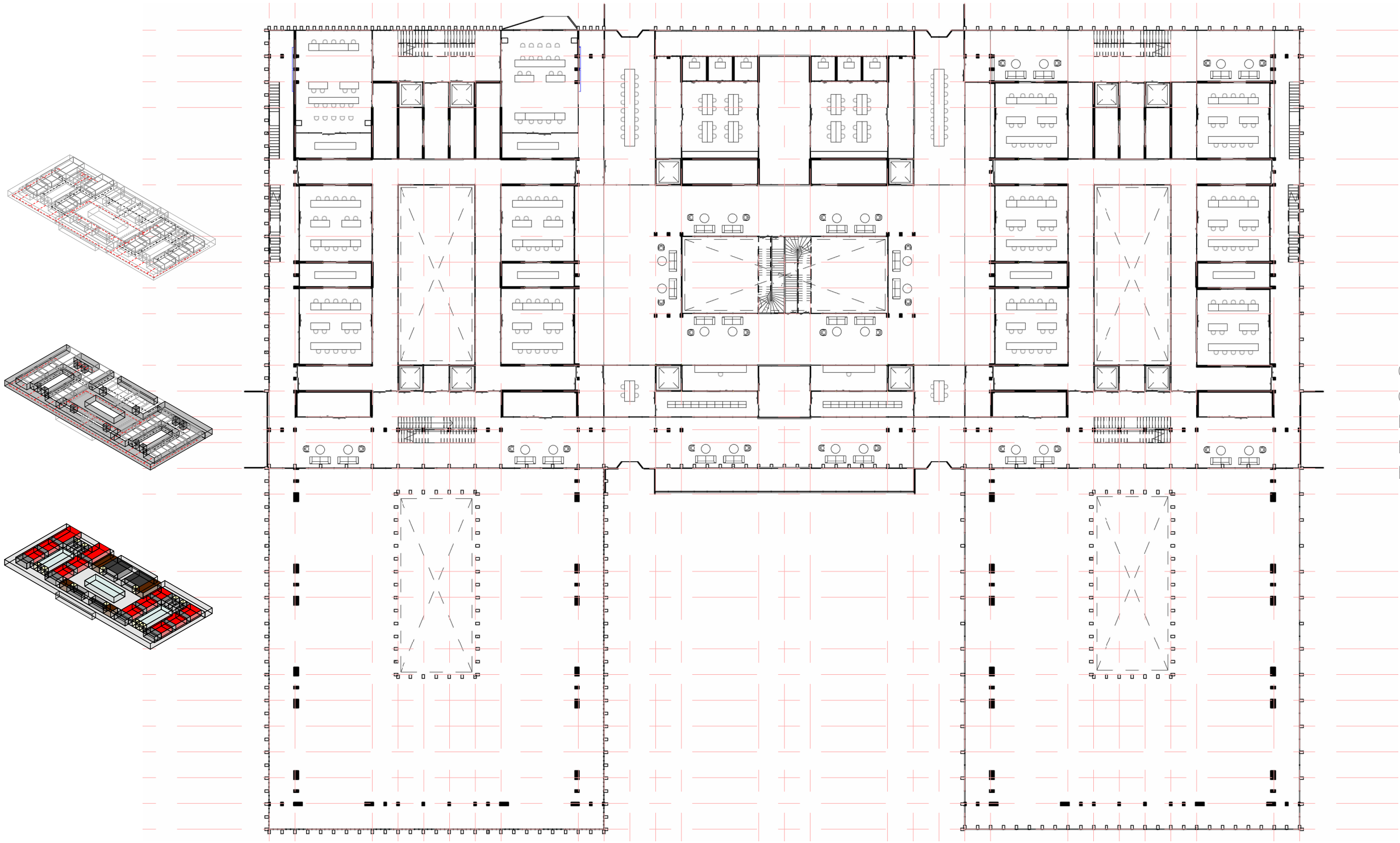

- Courtrooms
- Offices
- Evidence Storage
- Broadcast Rooms
- Hallway



4

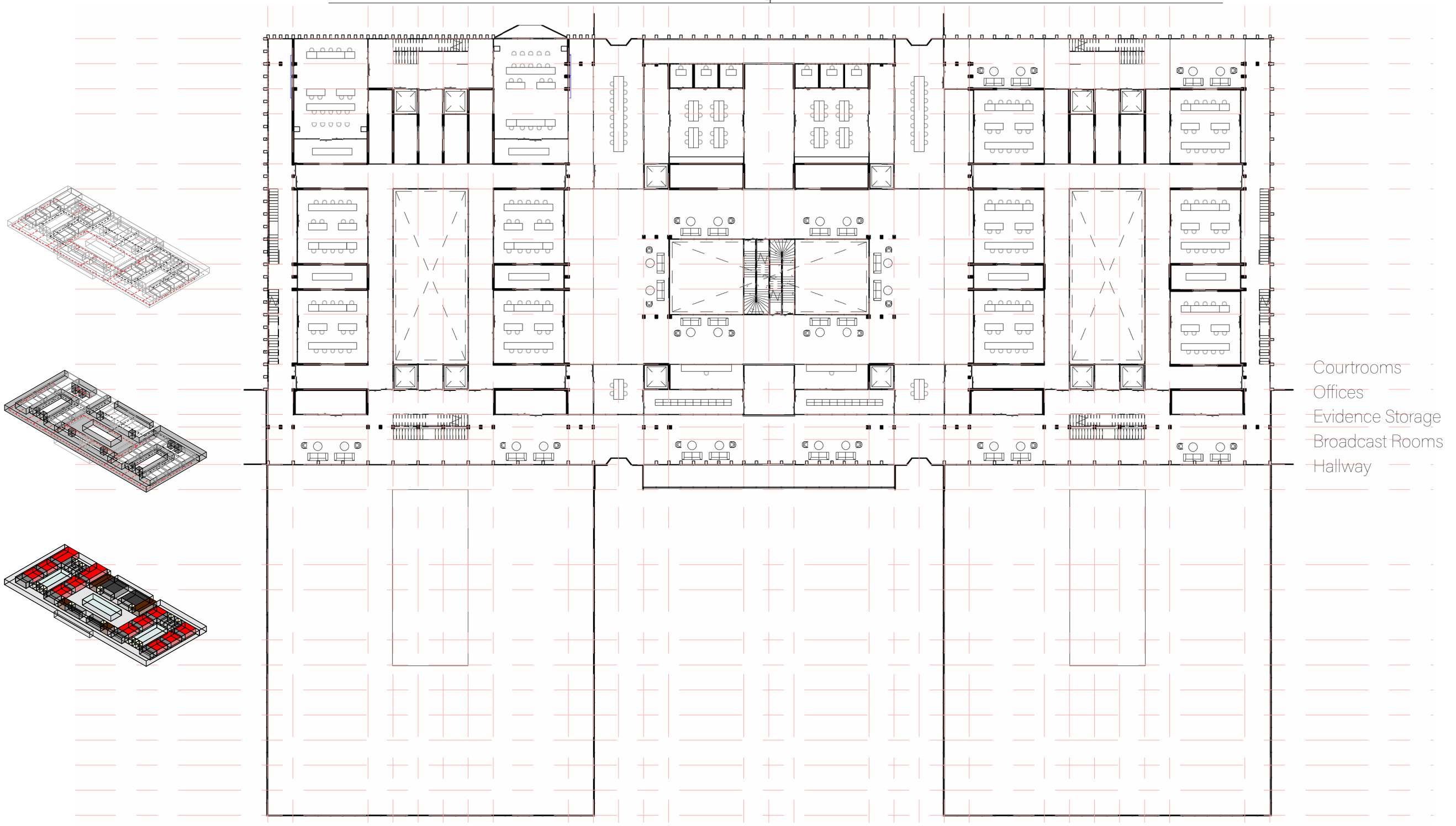

- Courtrooms
- Offices
- Evidence Storage
- Broadcast Rooms
- Hallway



4-6

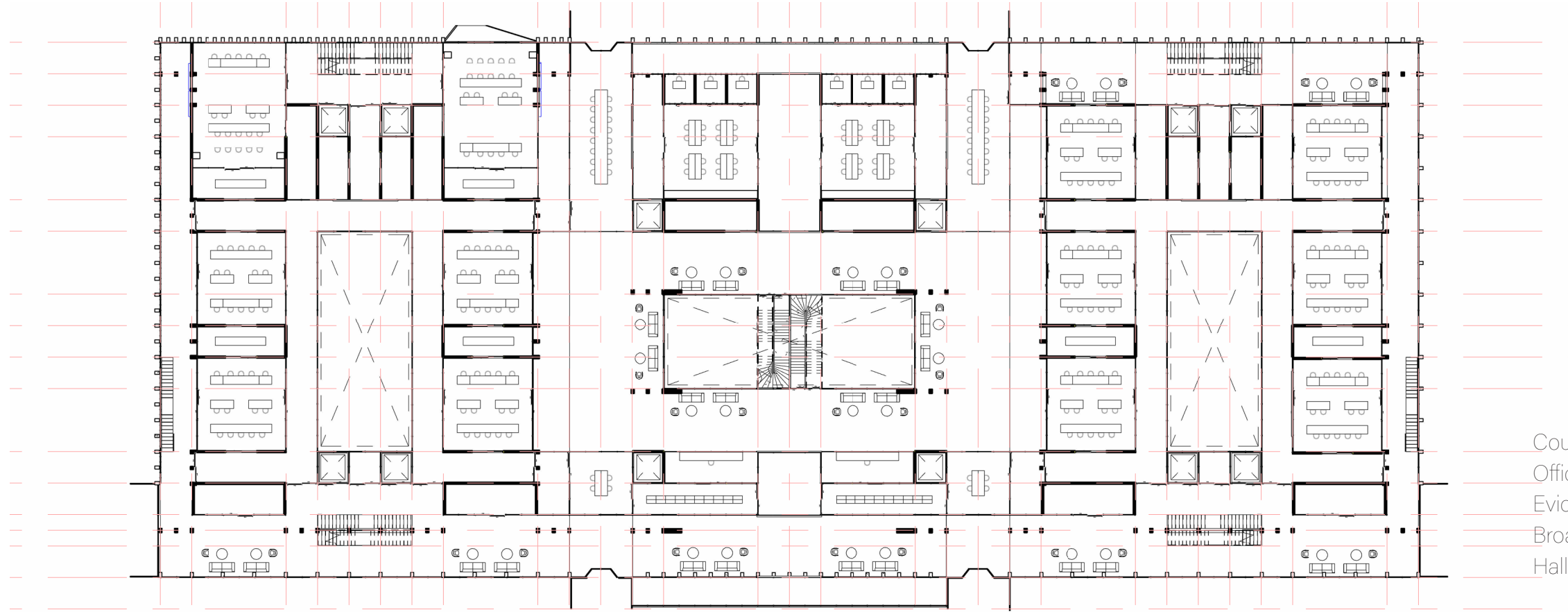

- Courtrooms
- Offices
- Evidence Storage
- Broadcast Rooms
- Hallway

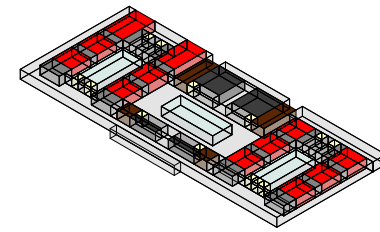
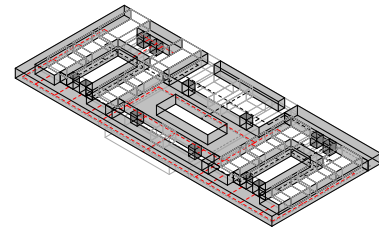
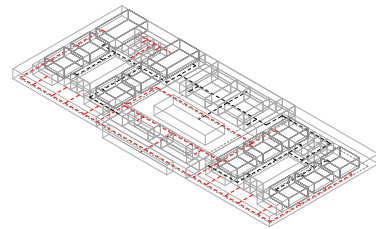

7

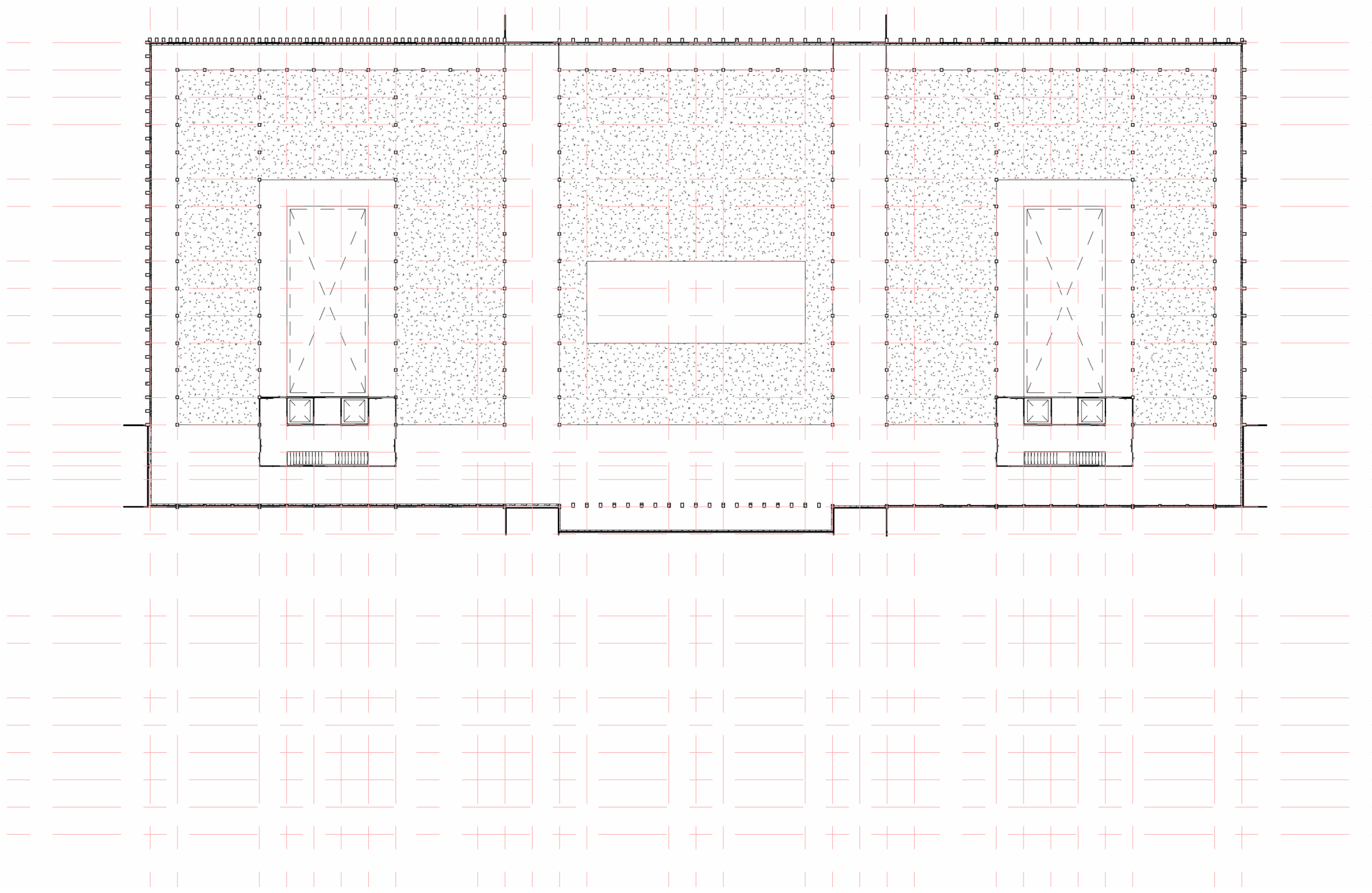

EXHIBITION ROOF



SECTION

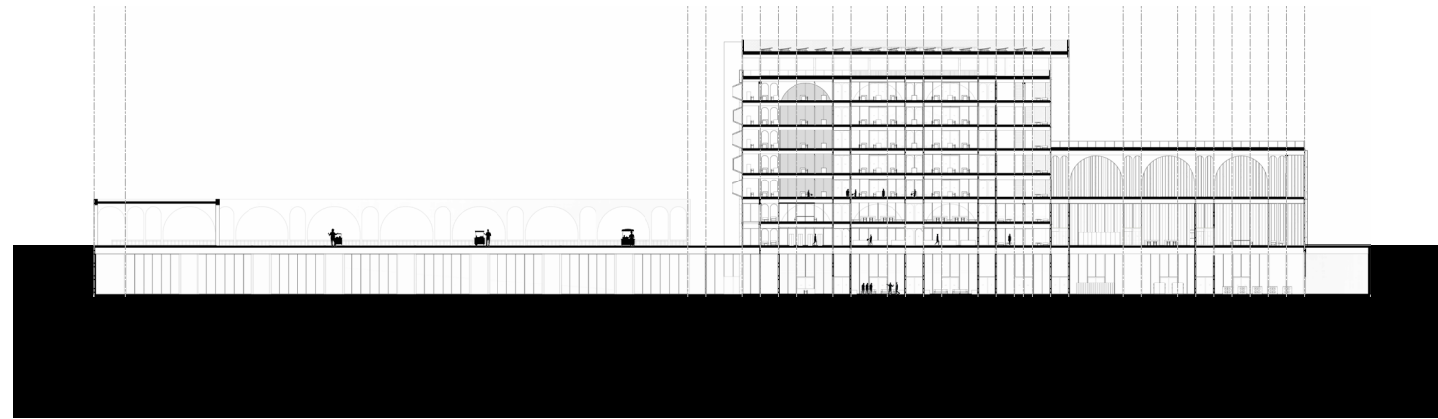

Sections A-A

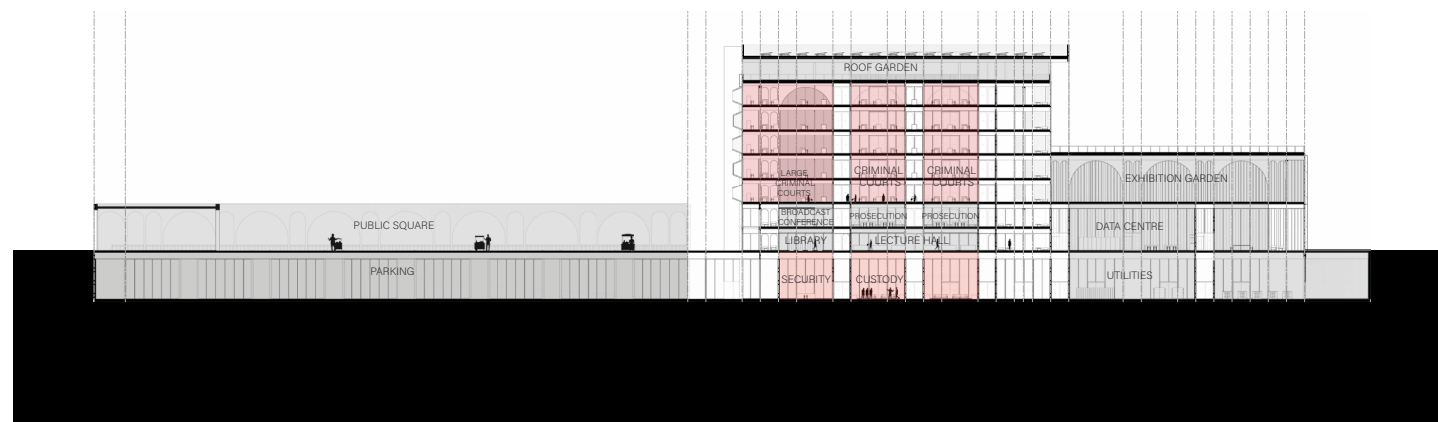

1:500

SECTIONS

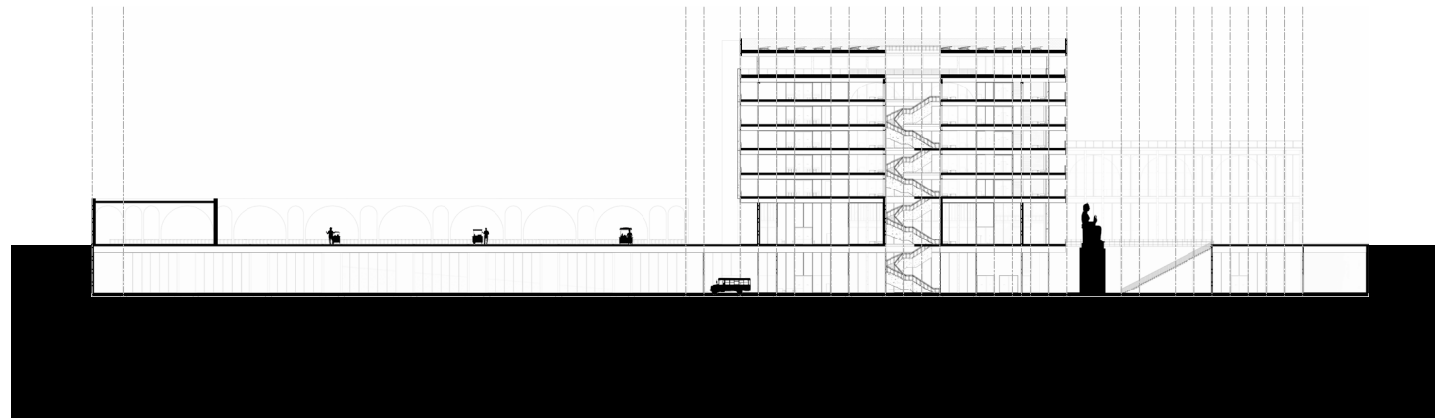

Sections B-B

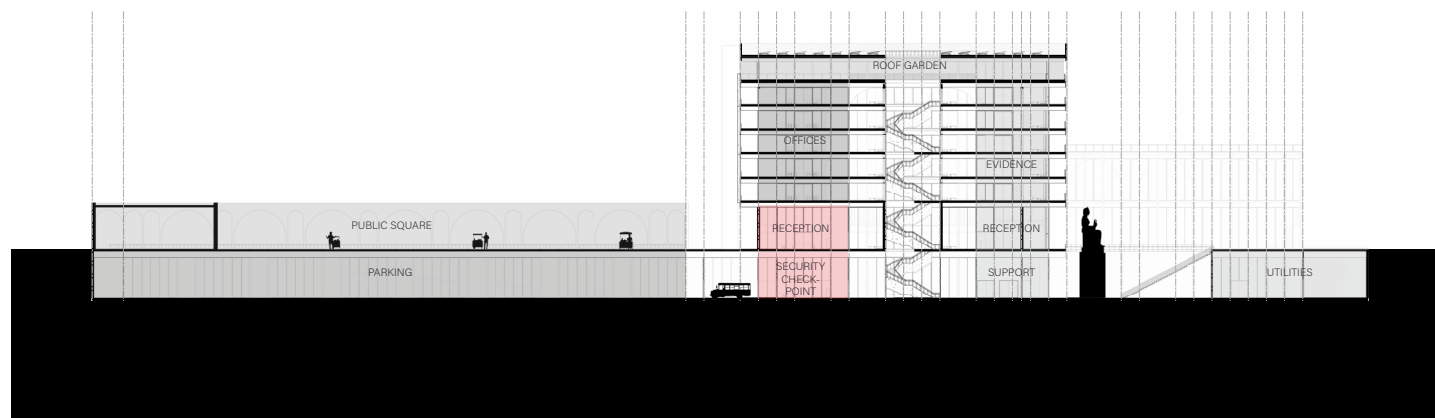

1:500

COURTROOMS

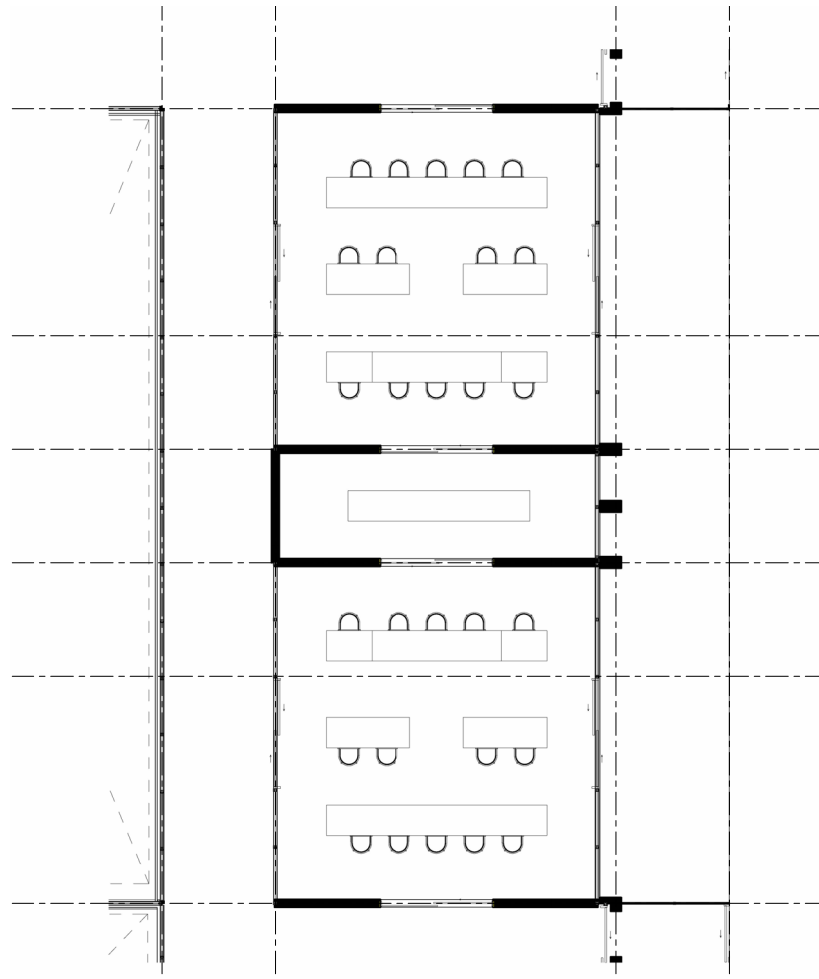

COURTROOMS

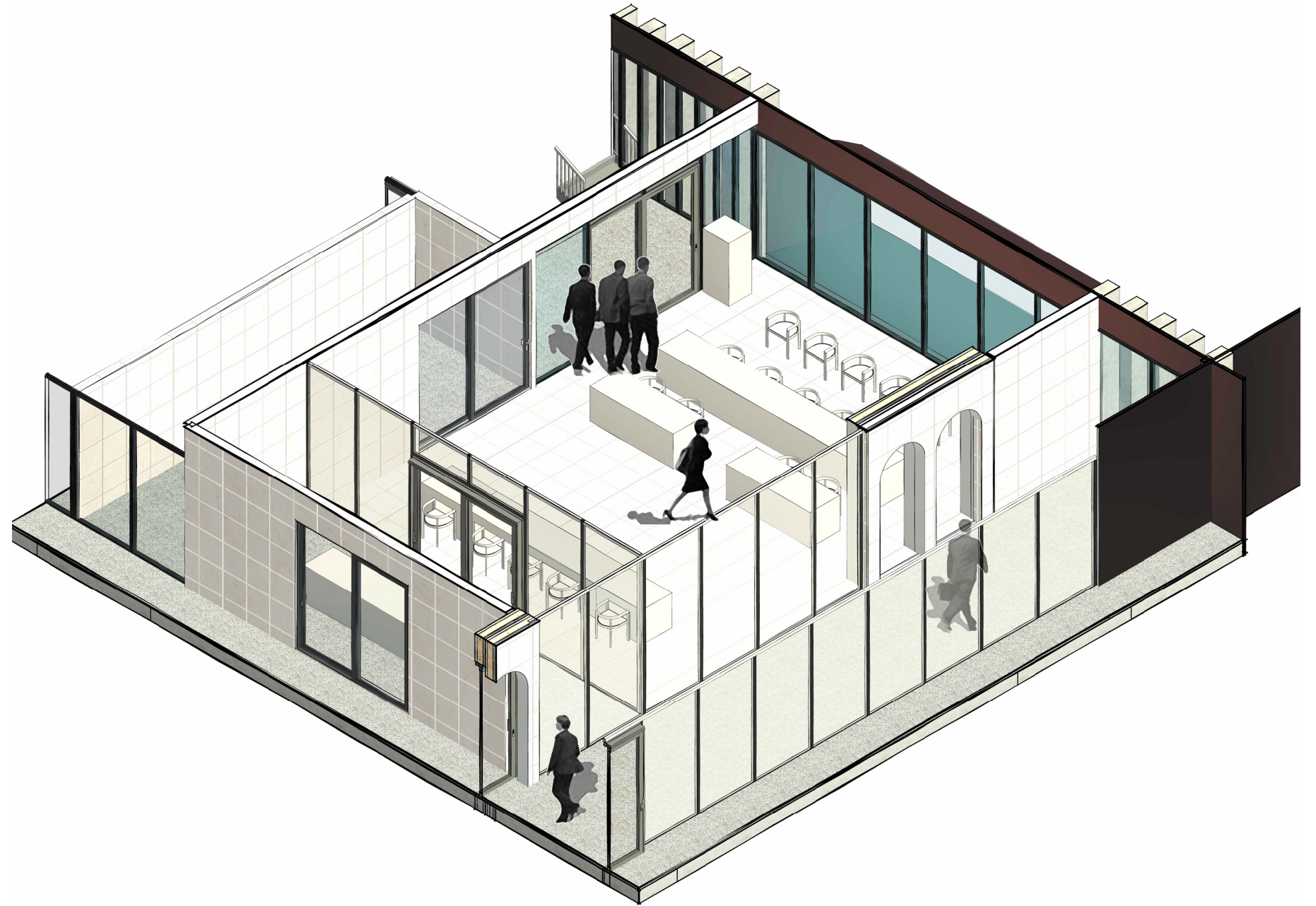
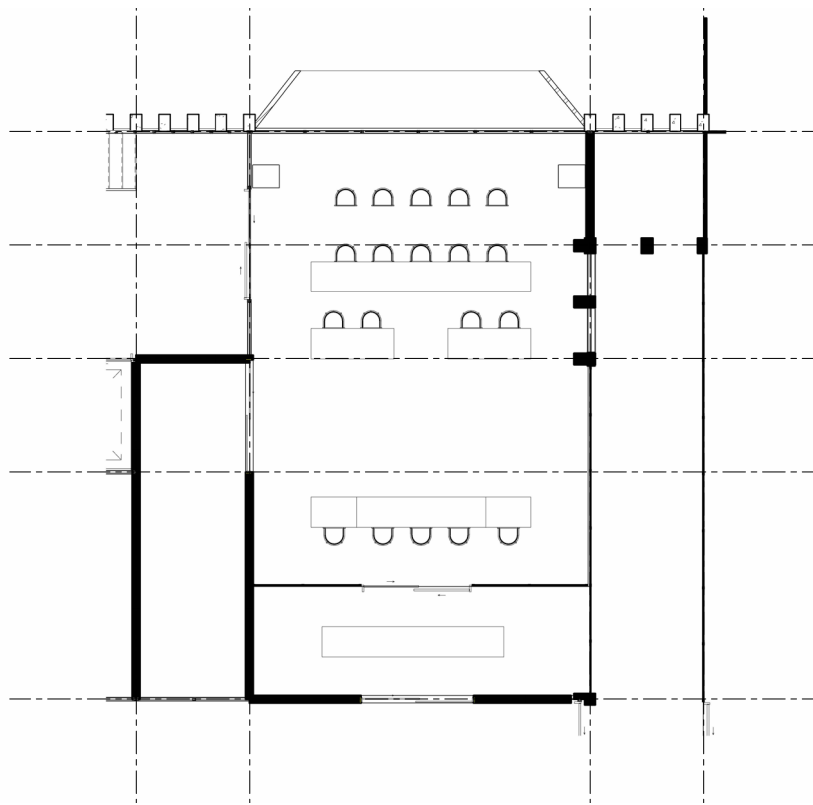

12X9 HCC

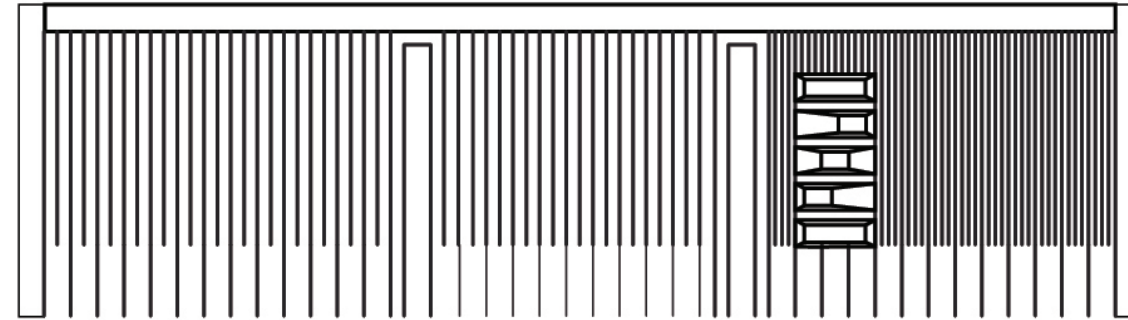

STEEL FRAMES
THRESHOLDS

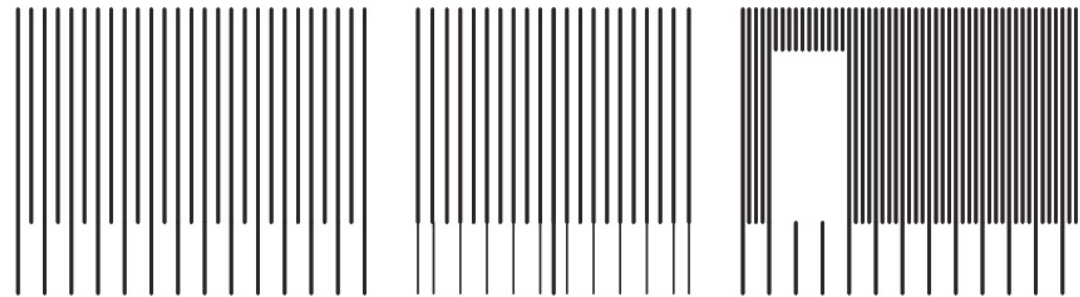

SOLAR LOUVERS
HIERARCHY

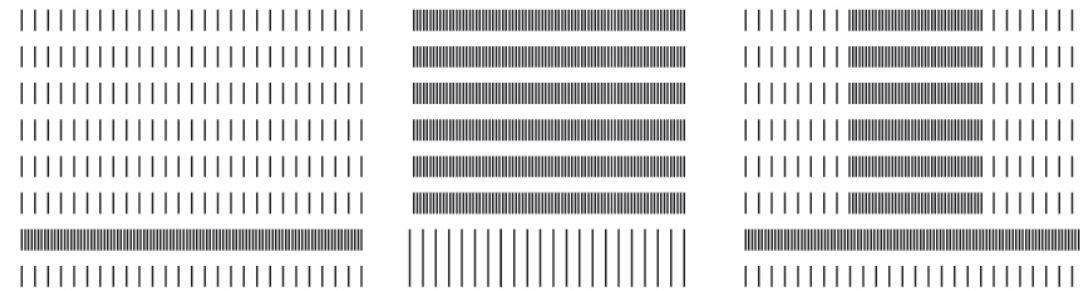

CURTAIN WALLS
TRANSPARENCY/ACCESS

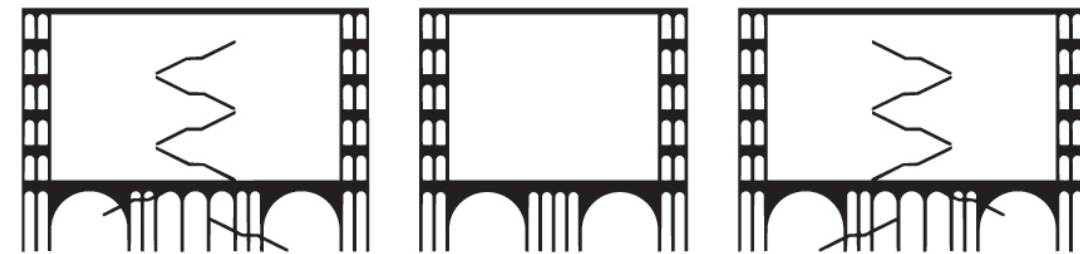

MARBLE ARCHES
FUNCTION



SOUTH FACADE/PIAZZA PUBLIC ENTRANCE

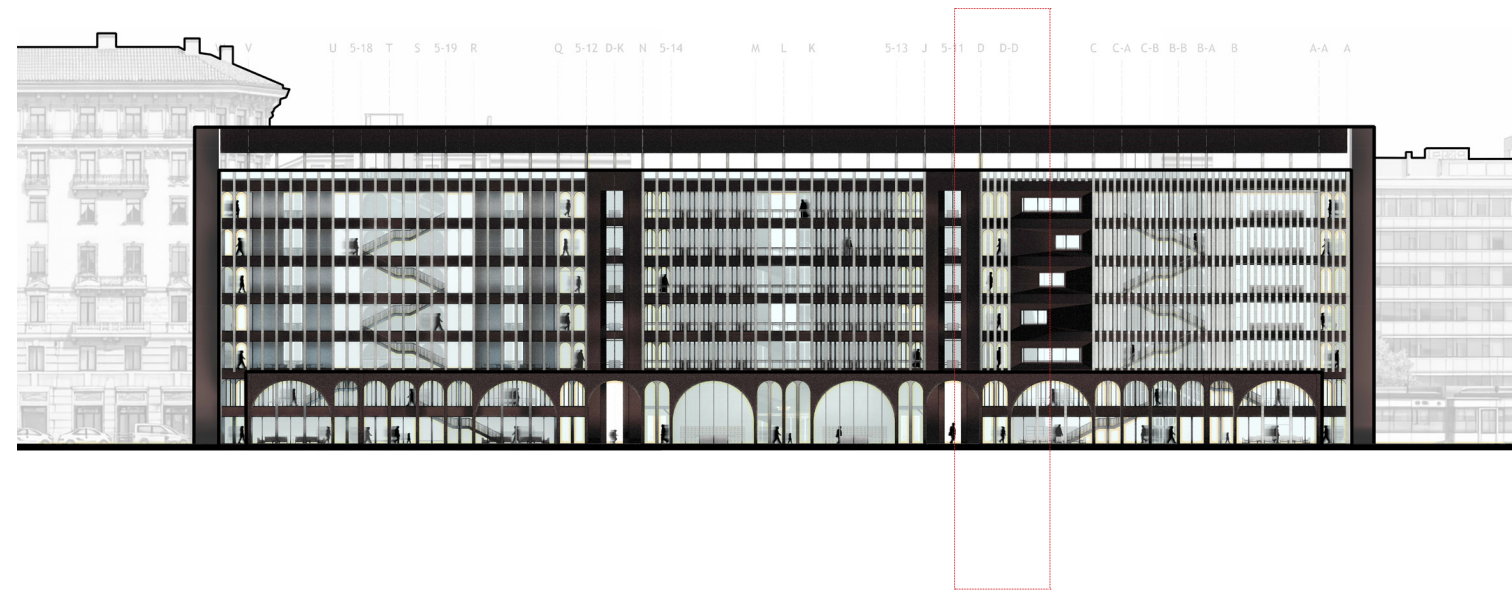

1:500

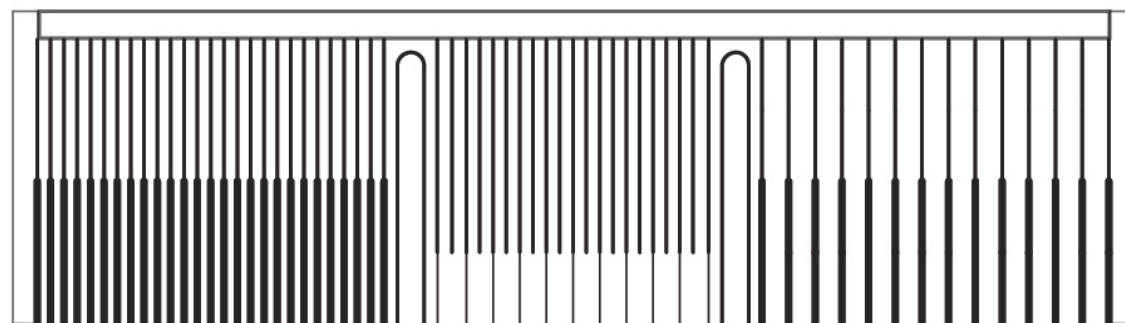

STEEL FRAMES
THRESHOLDS

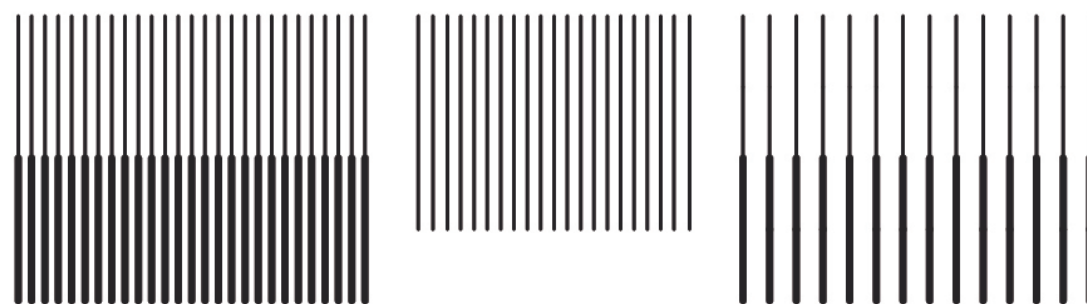

SOLAR LOUVERS
HIERARCHY

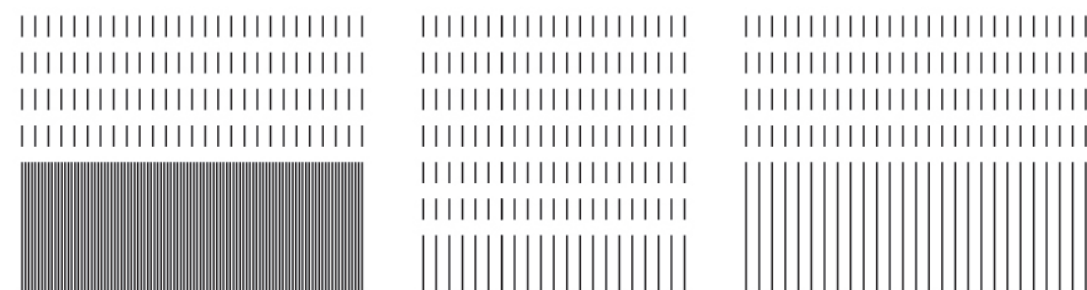

CURTAIN WALLS
TRANSPARENCY/ACCESS



MARBLE ARCHES
FUNCTION

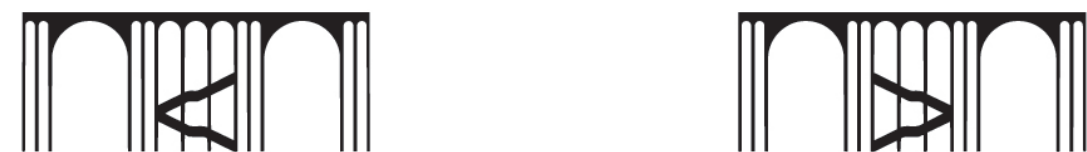

NORTH FACADE/ UNDERGROUND JUDICIAL

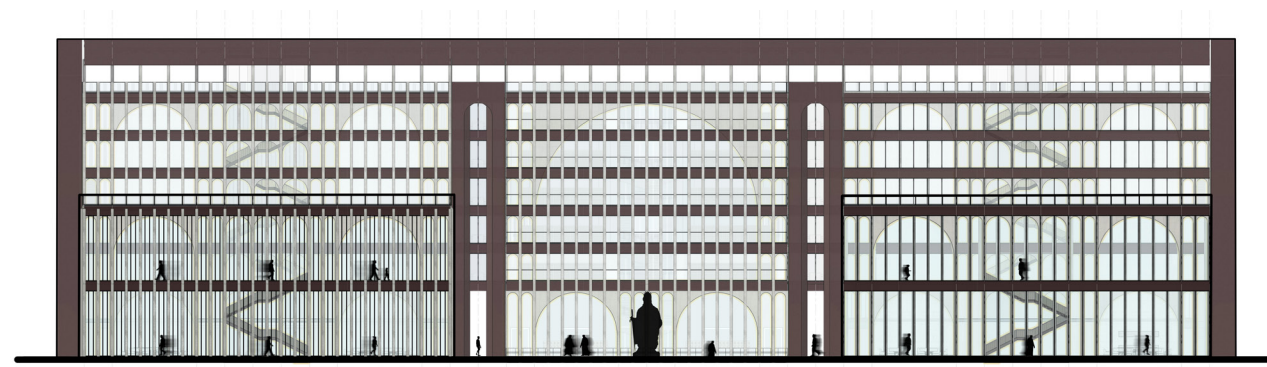

1:500

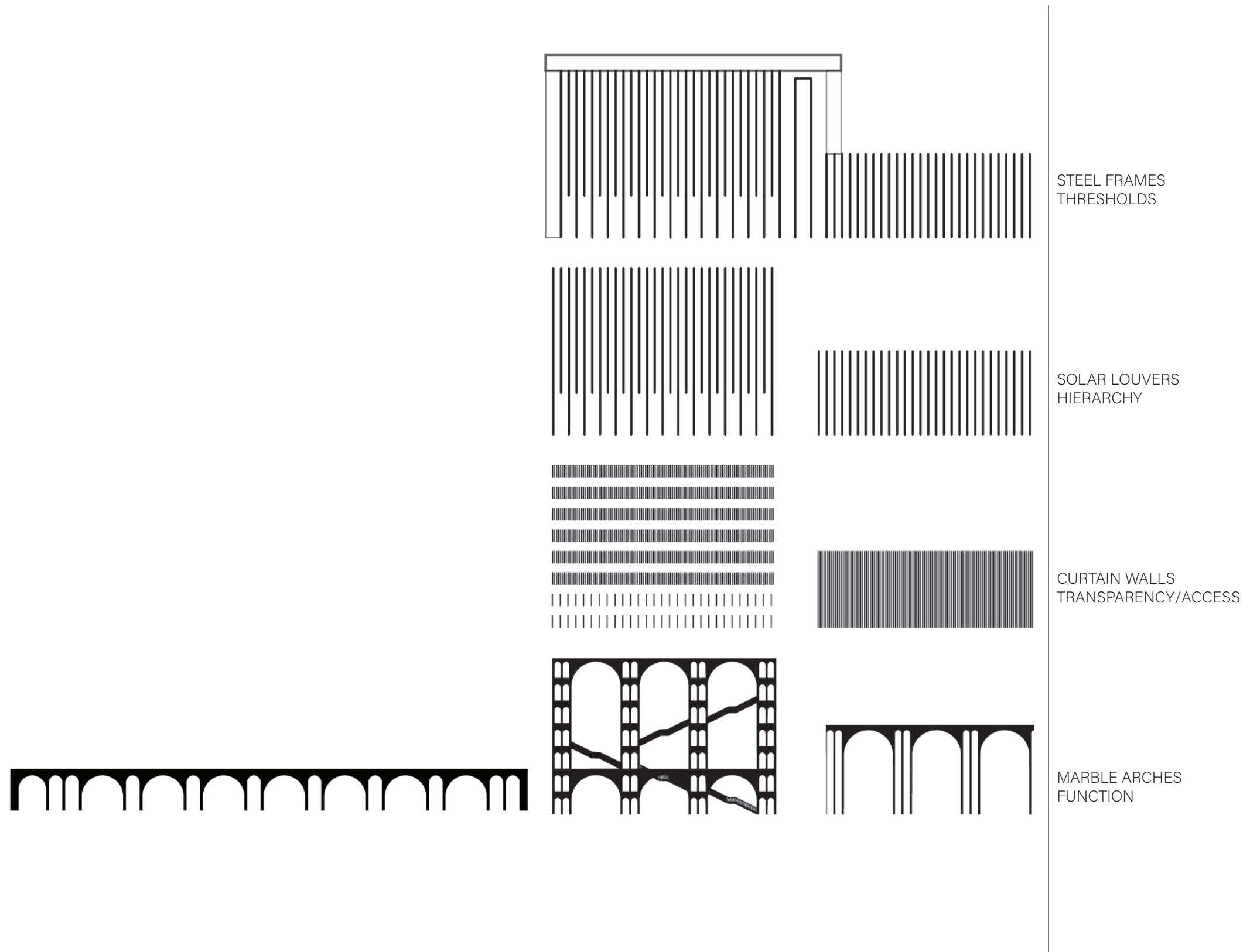

WEST FACADE/CRIMINAL COURTS-DATA CENTRE-EXHIBITION GARDEN



1:500

THRESHOLDS OF POWER

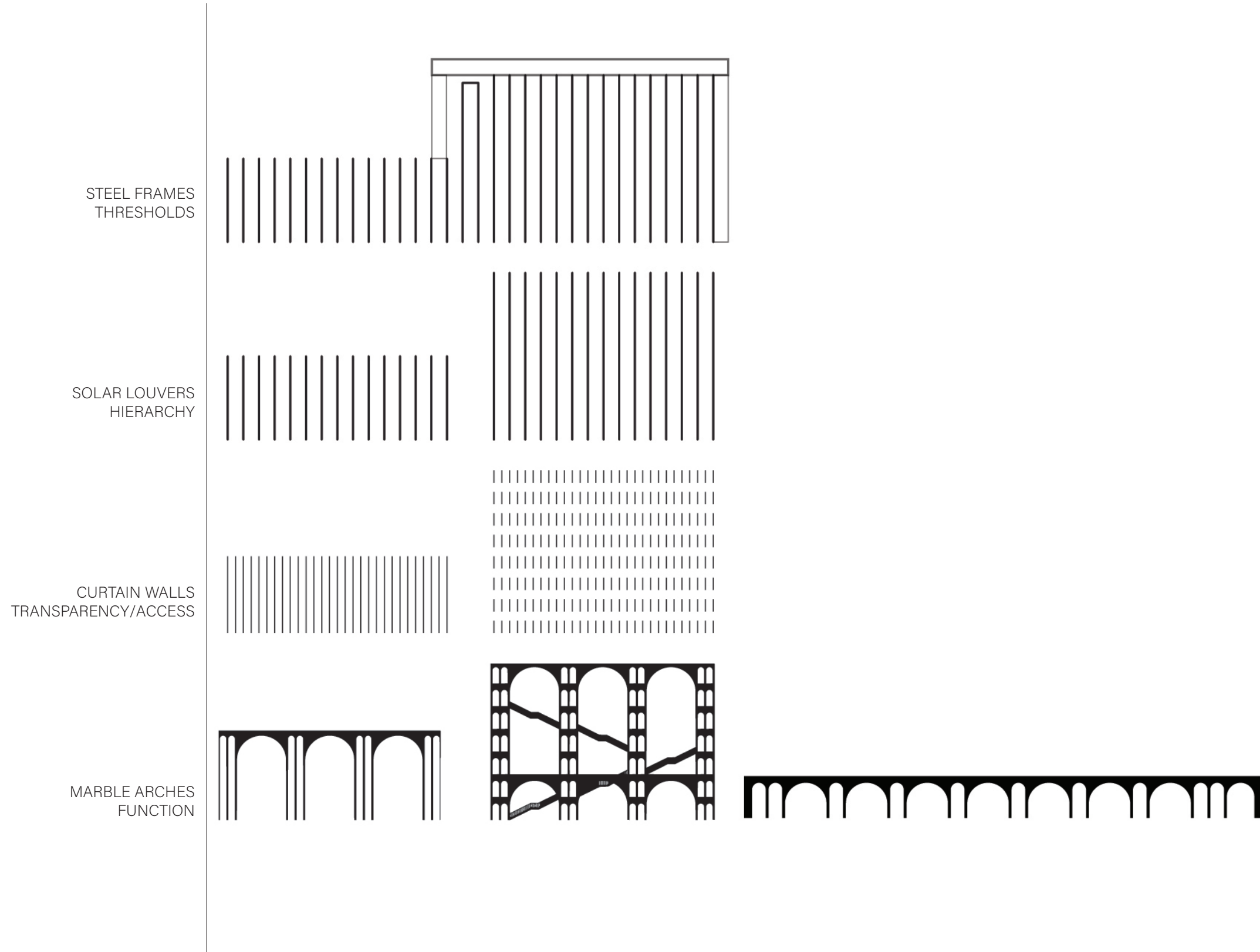

EAST FACADE/CIVIL COURTS-ART AND MEDIA CENTRE-EXHIBITION GARDEN



1:500

MATERIALS

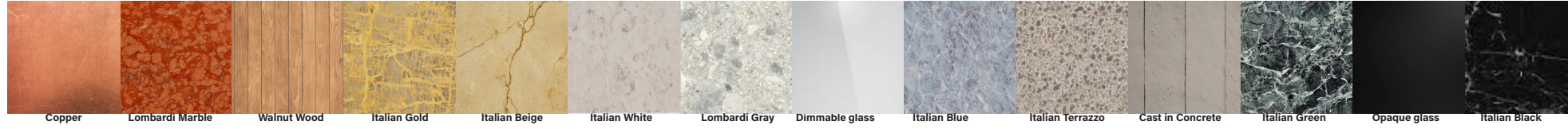

NEW MATERIALS

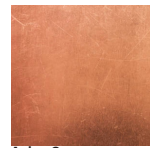

Aging Copper
Thresholds

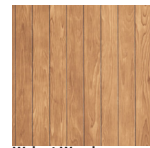

Walnut Wood
Furniture



Italian Beige
Hallways floor/walls

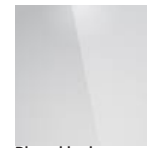

Dimmable glass
Facades

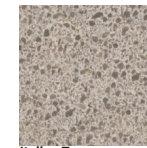

Italian Terrazzo
Hallway flooring
Recycled



Cast in Concrete
Monumental stairs
Structural floors
Recycled



Opaque glass
Interior smart glass

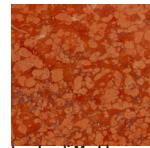

Lombardi Marble
Red custody

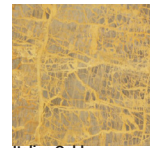

Italian Gold
Offices/public space

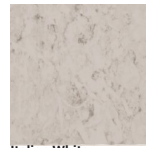

Italian White
Monumental walls



Lombardi Gray
Urban floors

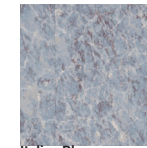

Italian Blue
Services floor

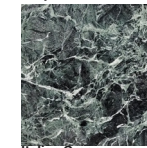

Italian Green
Communal spaces



Italian Black
Data center floors

REUSED

MATERIALS QUALITIES

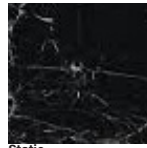

Static

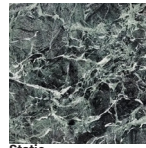

Static

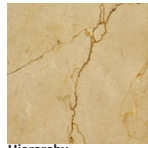

Hierarchy

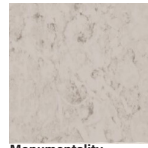

Monumentality



Recycled

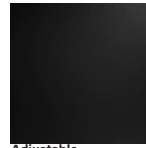

Adjustable

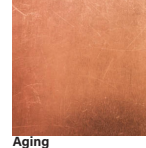

Aging

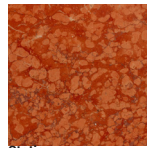

Static

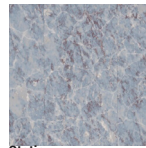

Static

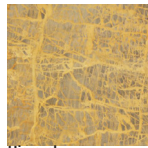

Hierarchy



Monumentality



Repurposed

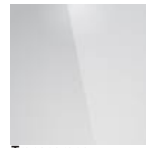

Transparency



Aging

FOLLOWING REQUIREMENTS

MATERIALS CONFIGURATION

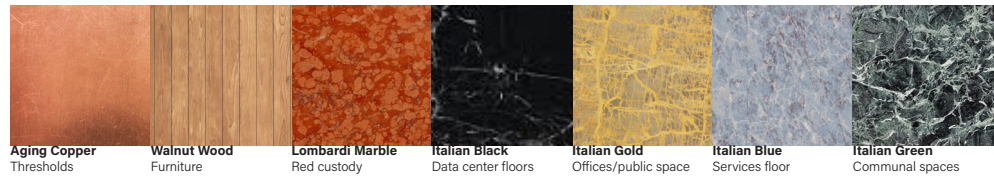

Aging Copper Thresholds
Walnut Wood Furniture
Lombardi Marble Red custody
Italian Black Data center floors
Italian Gold Offices/public space
Italian Blue Services floor
Italian Green Communal spaces

Main Spaces



Aging Copper Thresholds
Italian White Monumental walls
Italian Terrazzo Hallway flooring
Recycled Crushed
Italian Beige Hallways floor/walls
Opaque glass Interior smart glass

Hallways

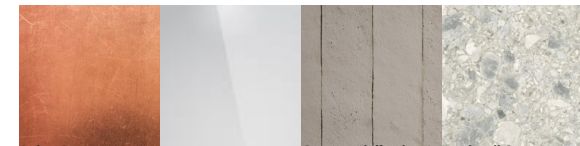

Aging Copper Thresholds
Dimmable glass Exterior facades
Concrete (effect) Monumental stairs
Structural floors
BIPV
Lombardi Gray Urban floors

Urban

FOLLOWING REQUIREMENTS

COURTROOMS

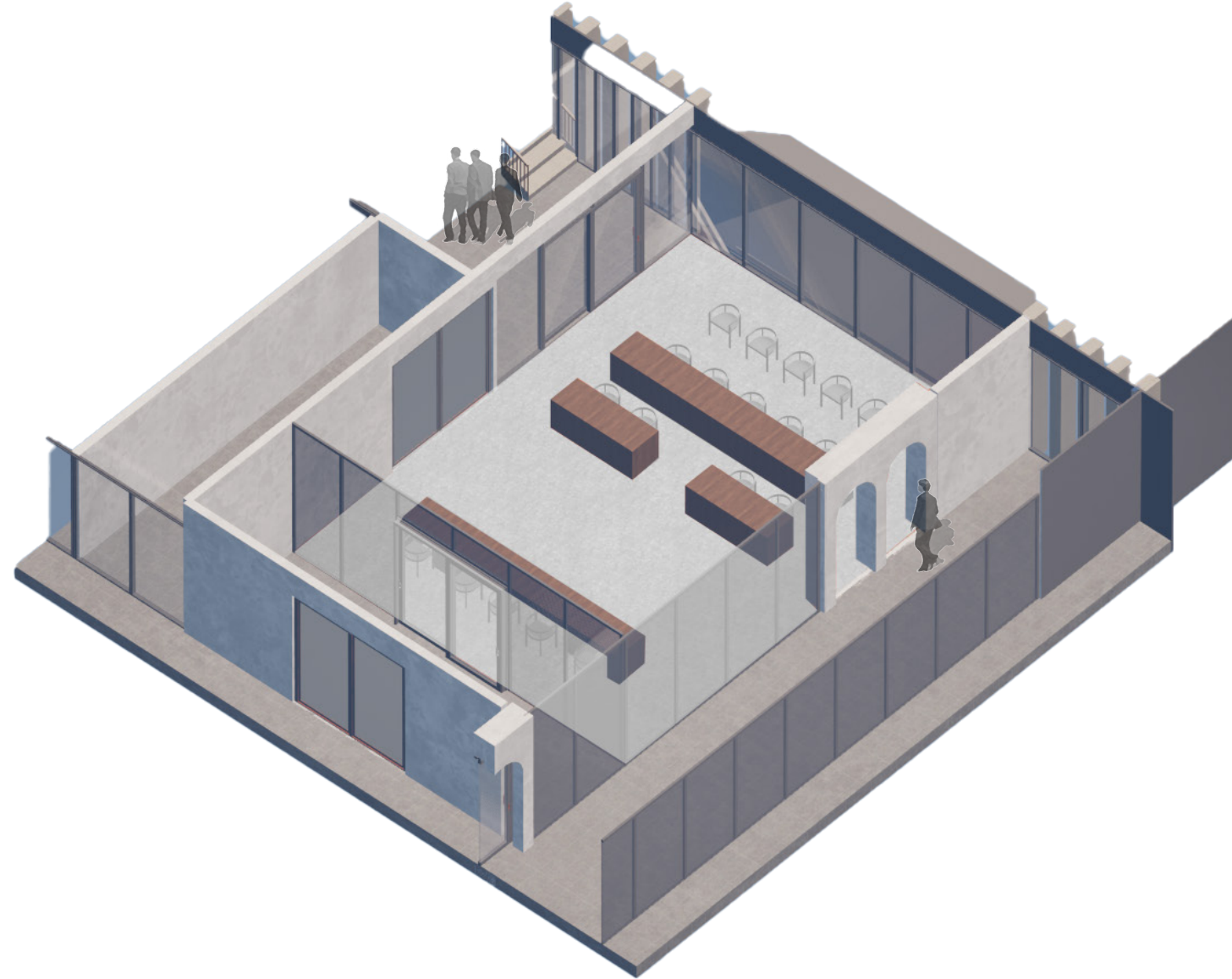

FURNITURES



Aging

FLOORS

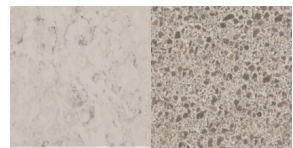

Reused

Recycled

INTERIOR WALL

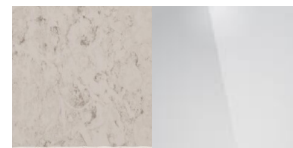

Reused

Adaptable/Adjustable

FACADE ELEMENTS

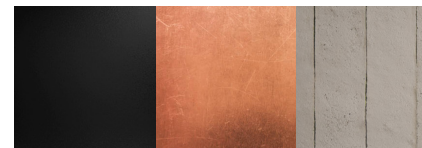

Adaptable/Adjustable

Aging

Reused

EXTERIOR FLOOR

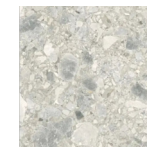

Reused

CUSTODY CENTRE

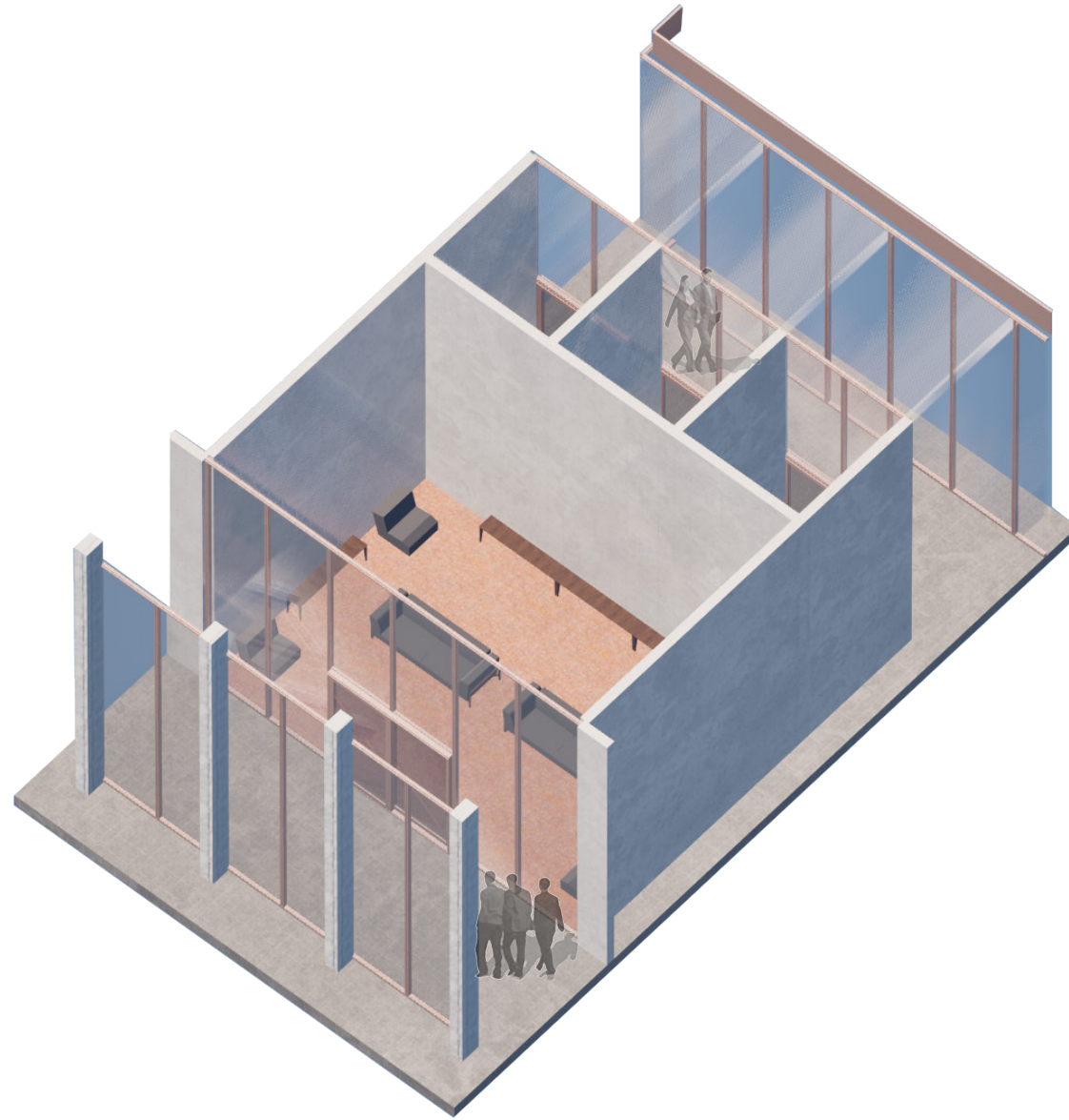

FURNITURES

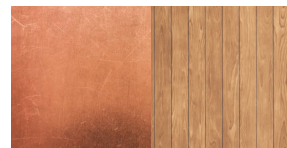

Aging

FLOORS

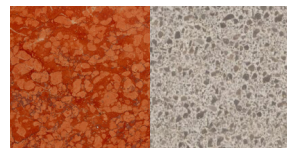

Reused

Recycled

INTERIOR WALL

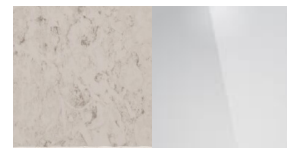

Reused

Adaptable/Adjustable

FACADE ELEMENTS

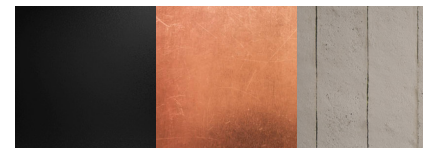

Adaptable/Adjustable

Aging

Reused

EXTERIOR FLOOR

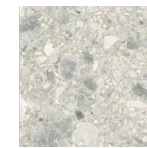

Reused

DATA CENTRE

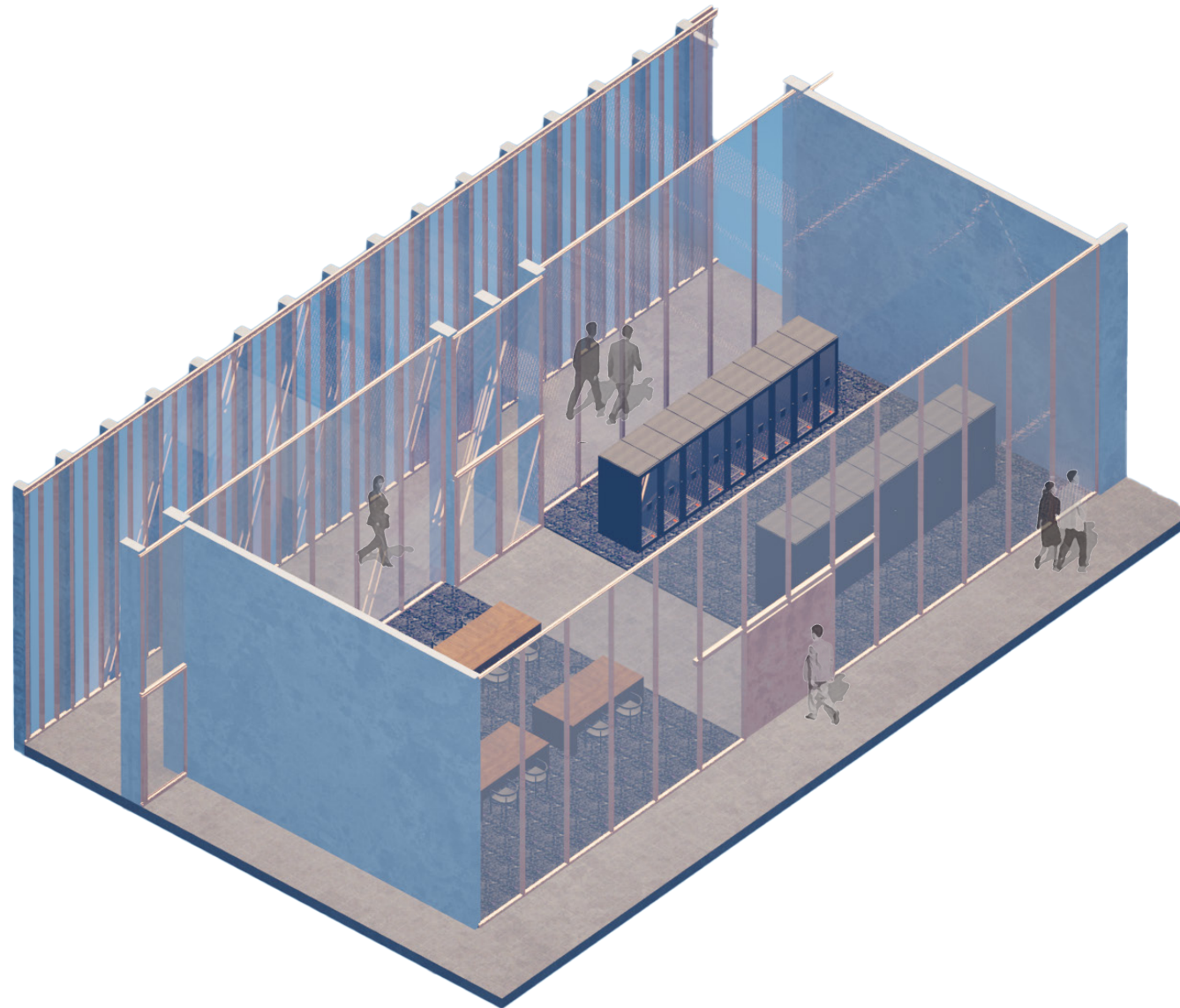

FURNITURES

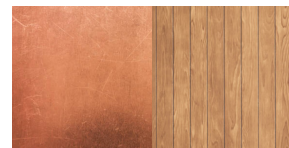

Aging

FLOORS

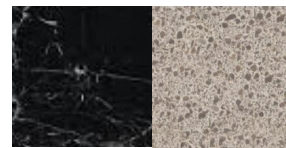

Reused

Recycled

INTERIOR WALL

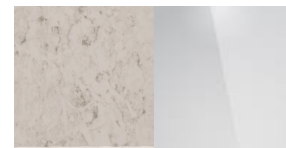

Reused

Adaptable/Adjustable

FACADE ELEMENTS

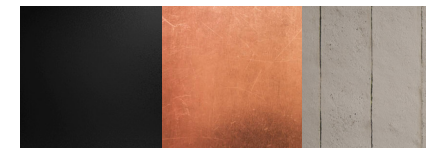

Adaptable/Adjustable

Aging

Reused

EXTERIOR FLOOR

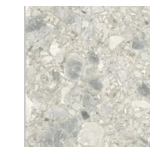

Reused

PUBLIC WINGS

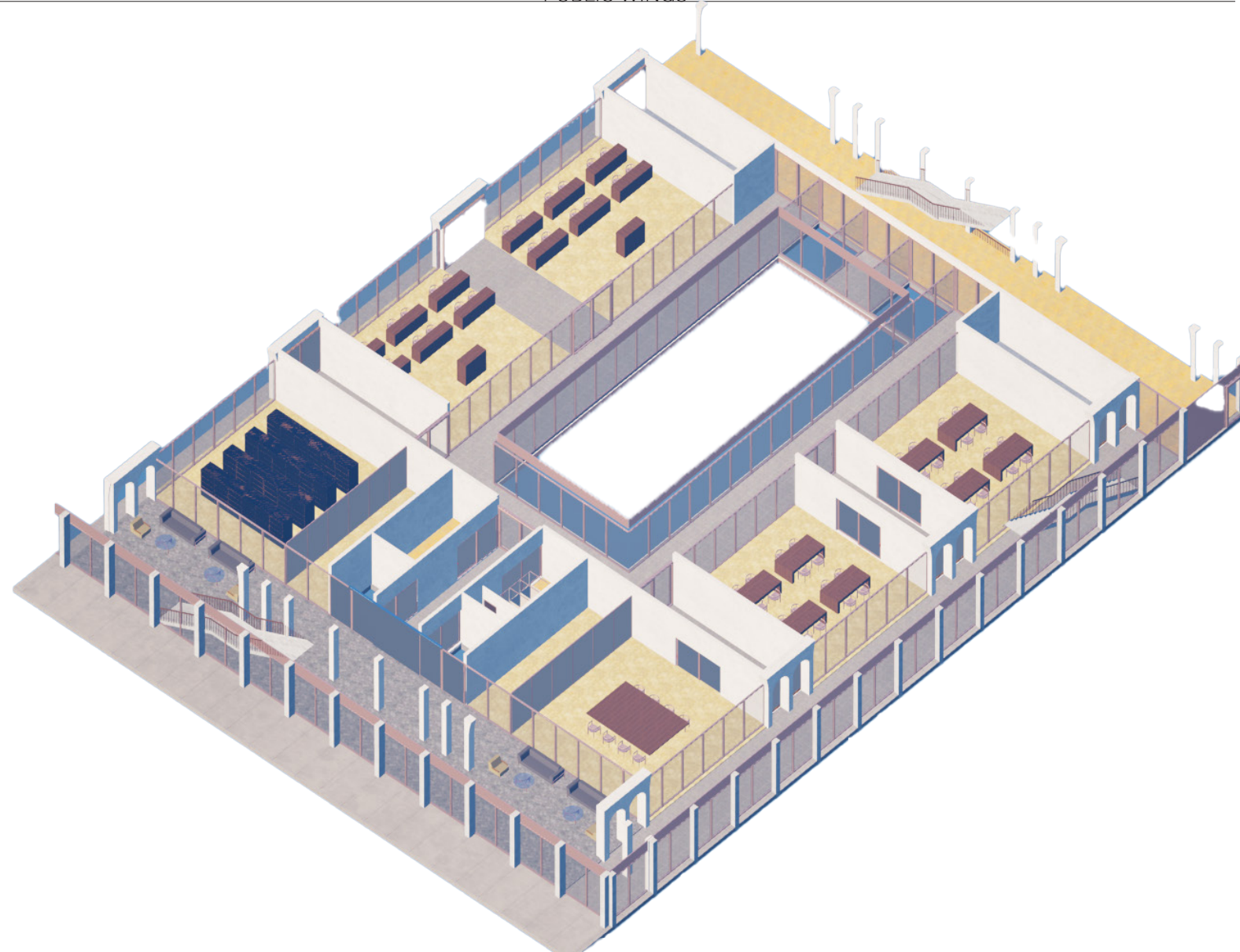

FURNITURES

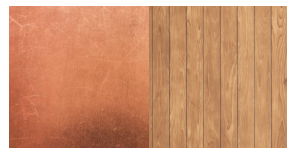

Aging

FLOORS

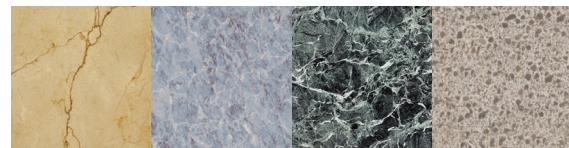

Reused

INTERIOR WALL

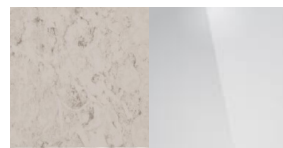

Reused Adaptable/Adjustable

FACADE ELEMENTS

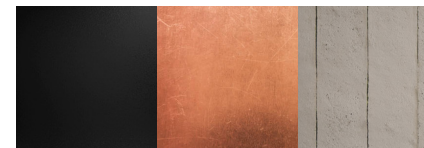

Adaptable/Adjustable Aging Reused

EXTERIOR FLOOR

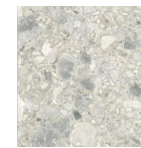

Reused

MIDDLE HALLWAY

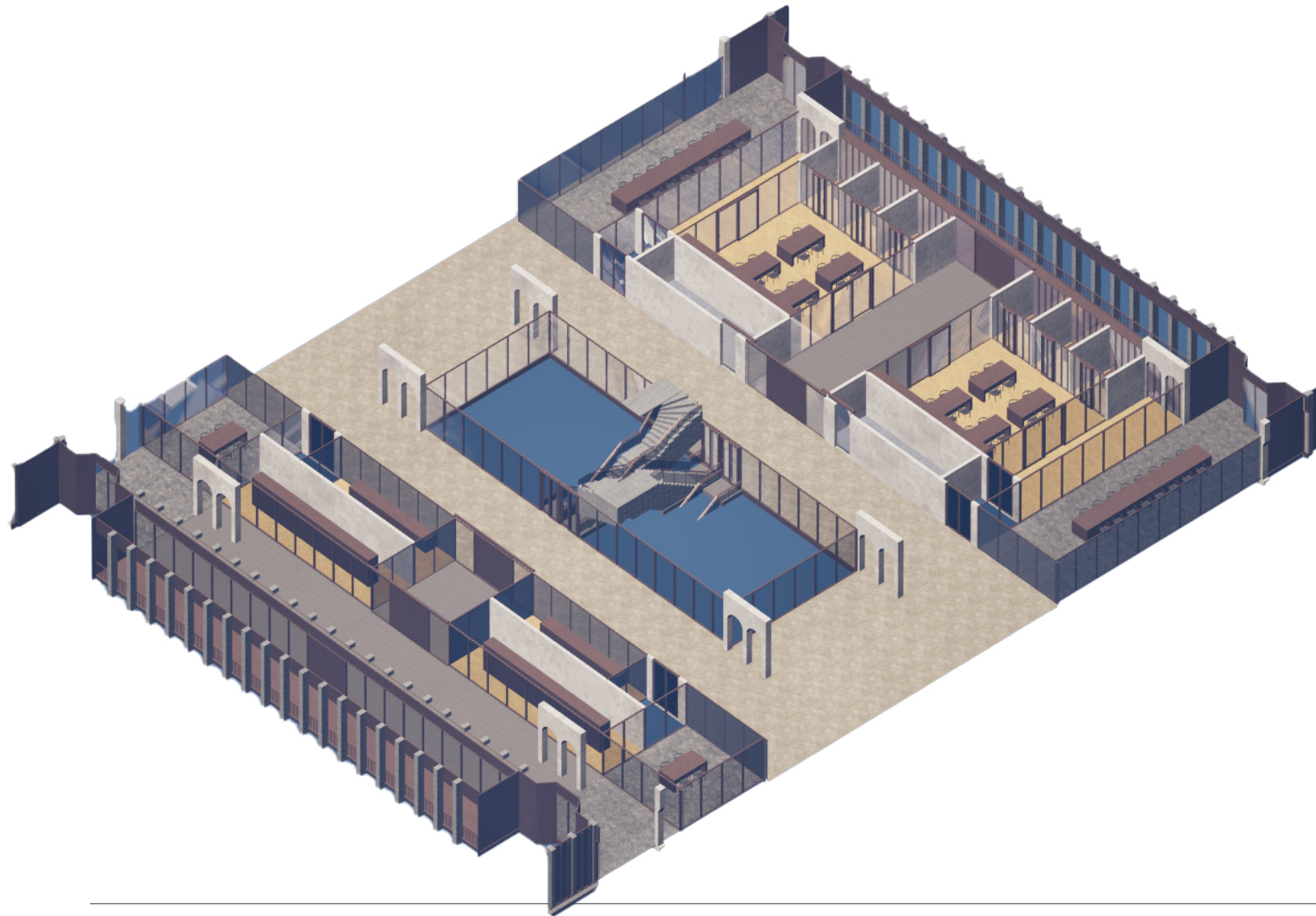

FURNITURES



Aging

FLOORS

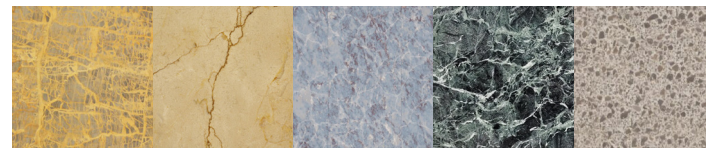

Reused

Recycled

INTERIOR WALL

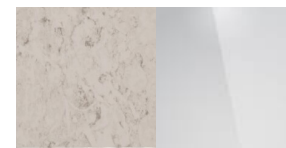

Reused

Adaptable/Adjustable

FACADE ELEMENTS

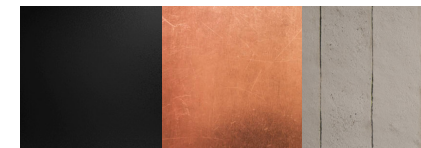

Adaptable/Adjustable

Aging

Reused

EXTERIOR FLOOR

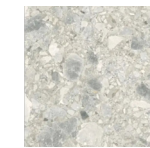

Reused



PIAZZA IMPRESSION



CUSTODY CENTRE



COURTROOM IMPRESSION



CENTRAL HALLWAY



HALLWAY IMPRESSION



EXHIBITION GARDEN

CONTENT

INTRODUCTION
THEORY
RESEARCH
CONCEPT
DESIGN BRIEF
DESIGN
TECHNICAL
CONCLUSION

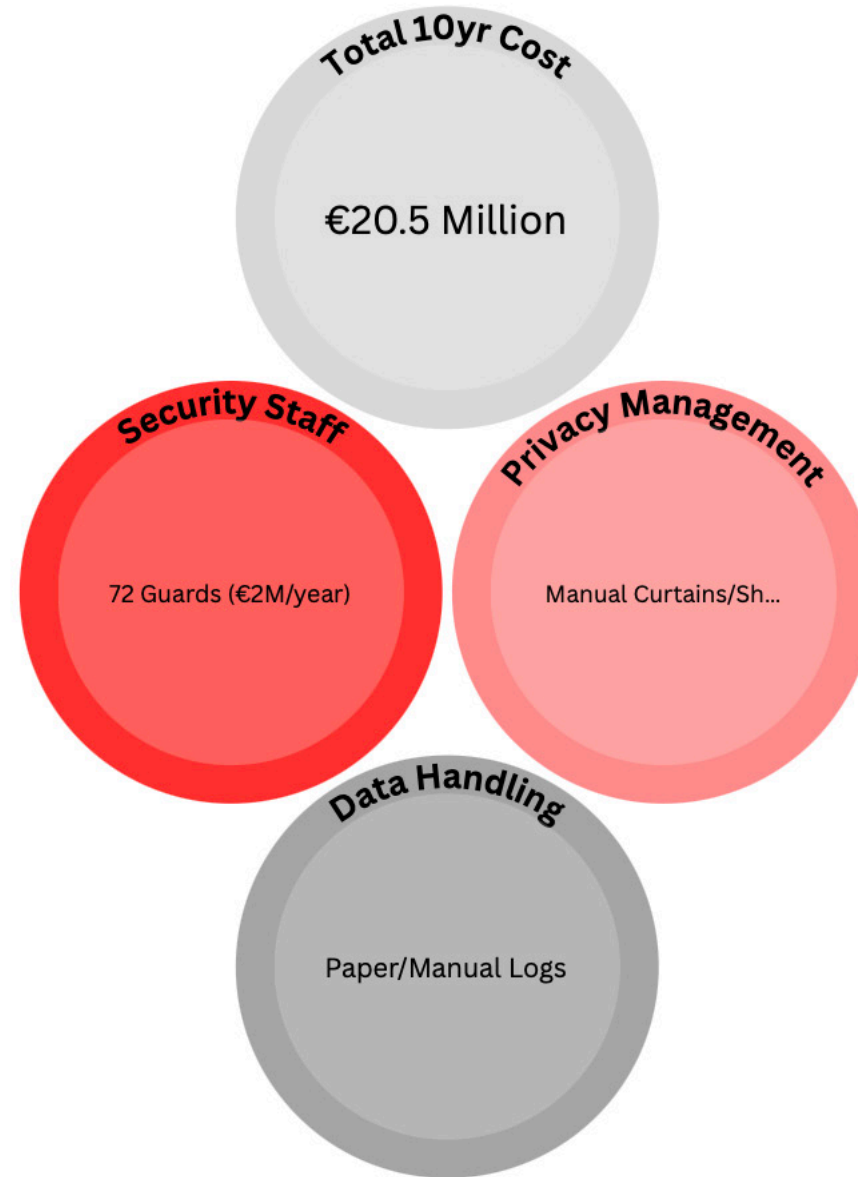

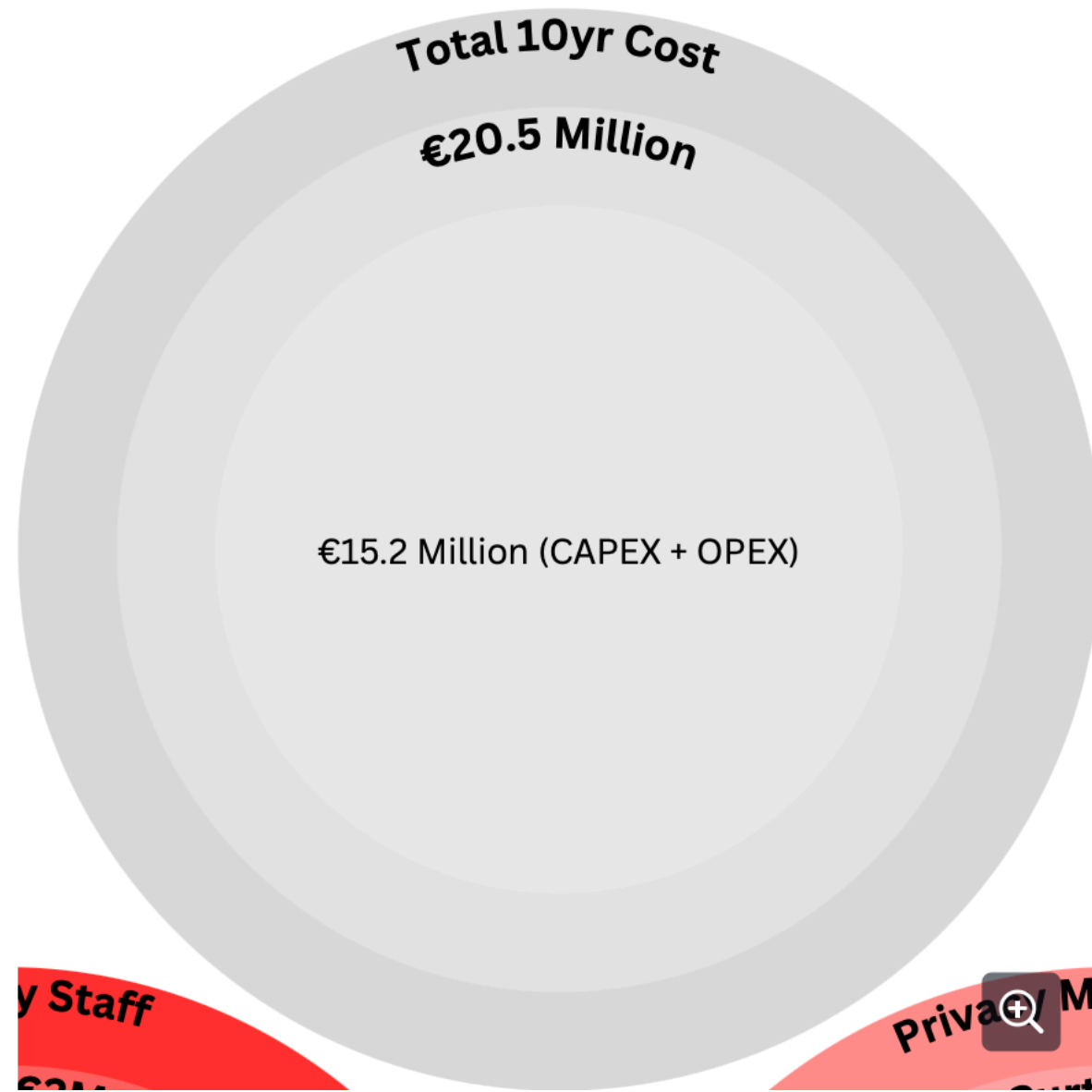



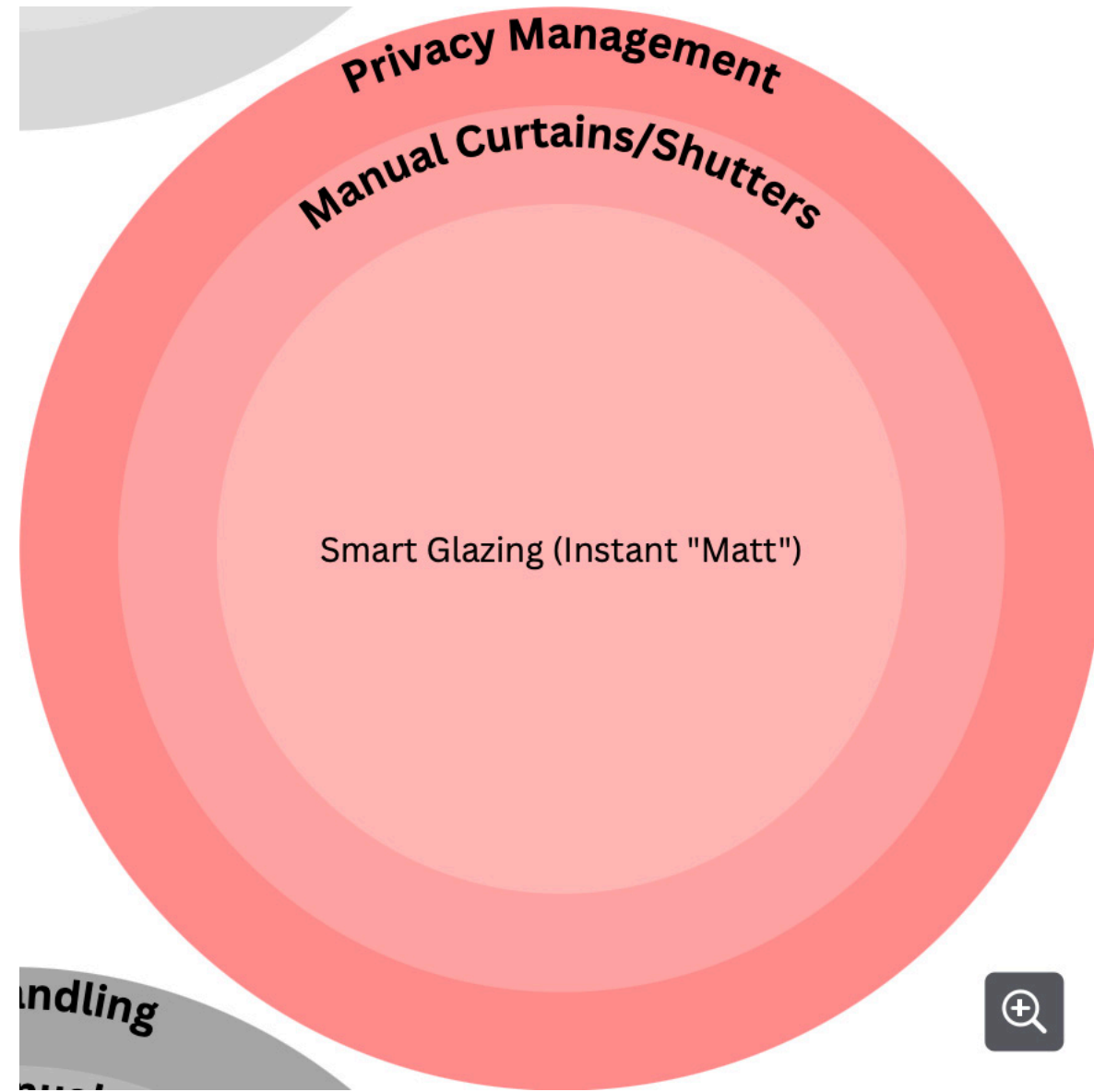

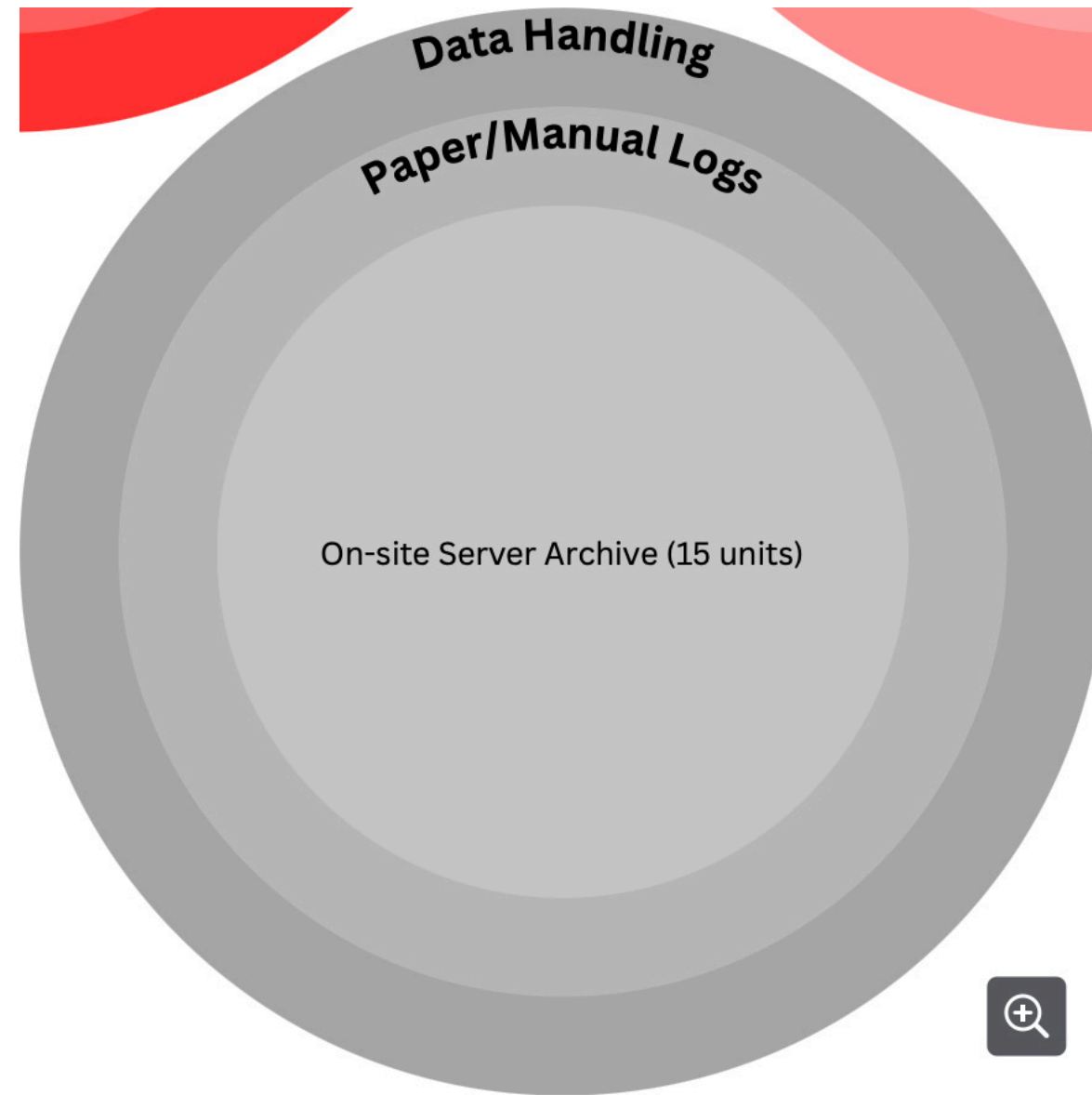

NEW STRUCTURE

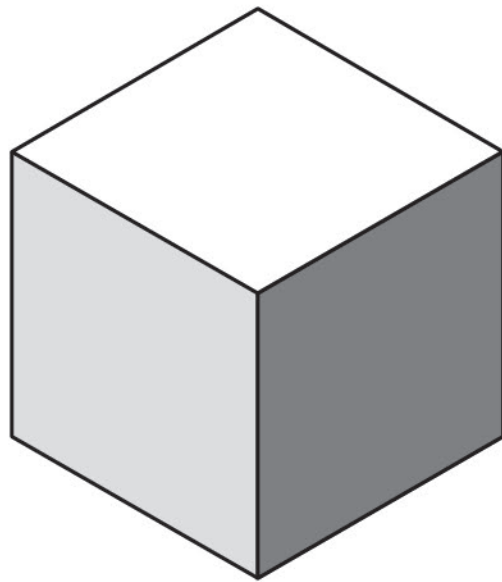

Smart glasses/Data centre

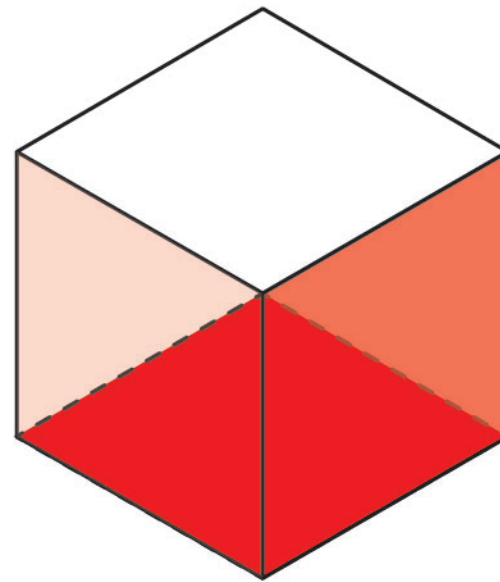

Cameras/sensors

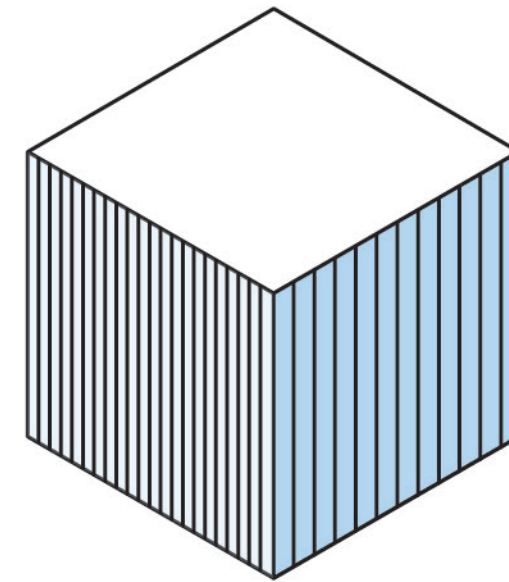

Glass architecture

RECONFIGURED SECURITY

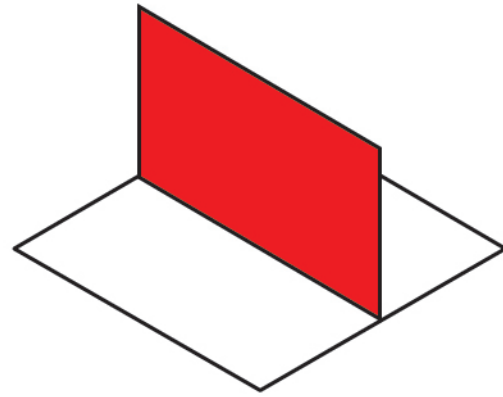

security centralized barriers (threshold model)

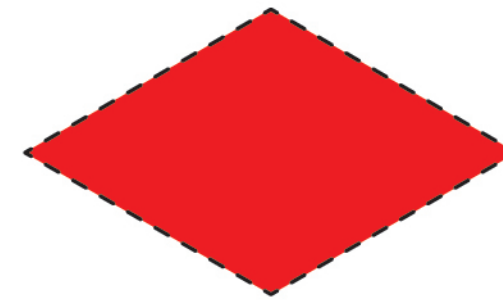

security diffused across space (field condition)

REUSING BUILDING

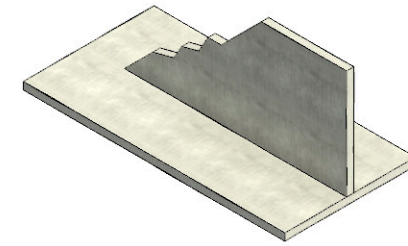
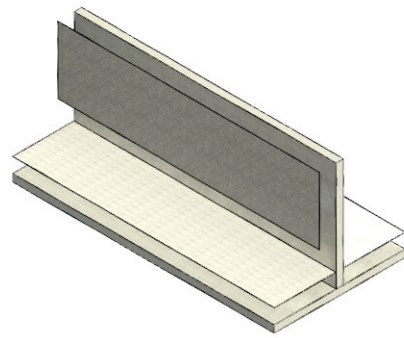
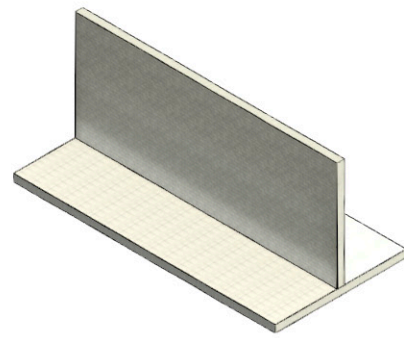

REUSING BUILDING

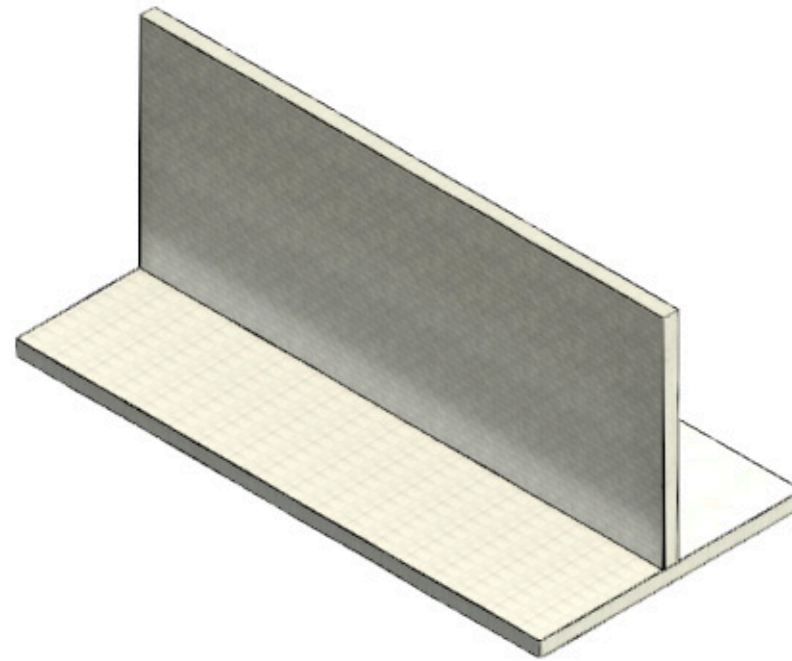

Total Space: 40,000 m²
Number of Rooms: 120+
Primary Material: Lambordian Marble/Stones, Concrete
Estimated Stone Slabs: 77,000 units (standard sizing)
Artistic Mosaics: Millions of individual tesserae

REUSING BUILDING

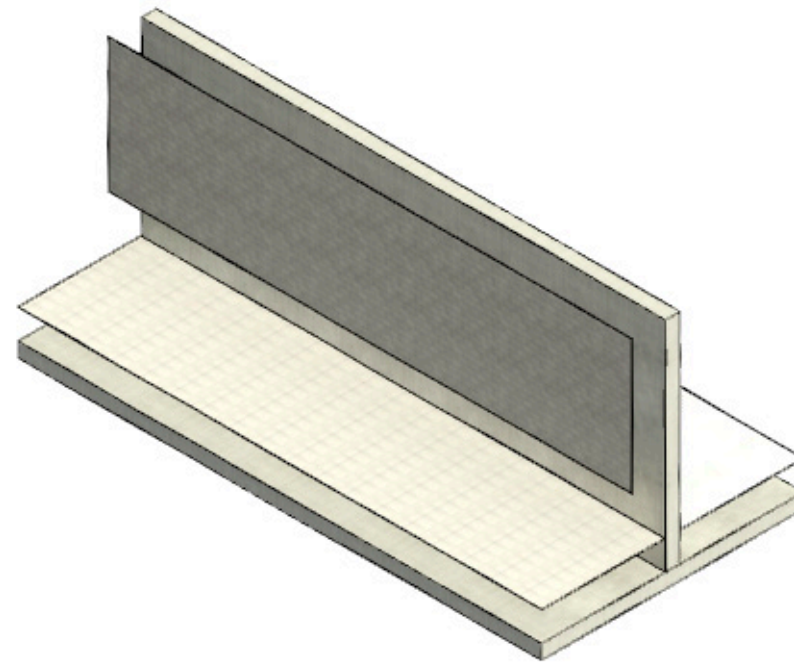

Separation and Grout Removal
The "Pop" (Lifting)
Cleaning the Underside
Restoration for Reuse

Mechanical Raking, Heat Application
The Air Bladder Method, Vibration-Assisted Lifting
Precision Chiseling, Diamond Grinding
Lapping, Honing/Polishing

REUSING BUILDING

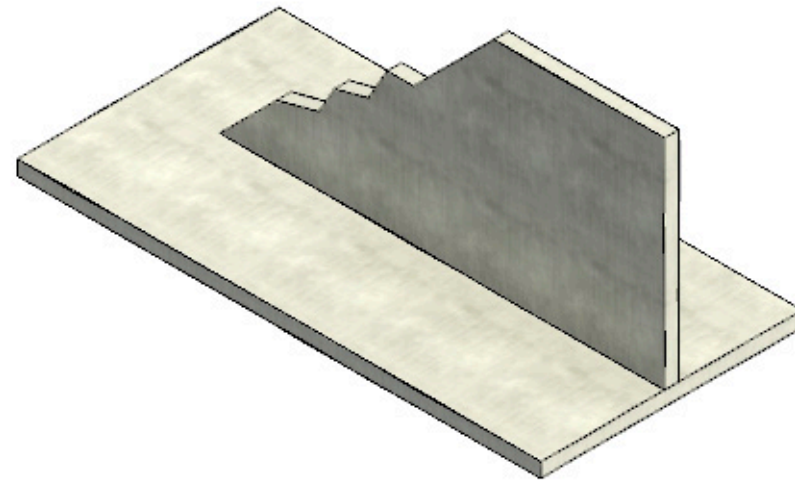

Recycled Concrete Aggregate (RCA)
Crushing and Grading
Removing the "Mortar Skin"
The Mix Design
Admixtures

Venetian Terrazzo, "upcycle" stone
The "Crush"
The Binder
The Pour
Grinding and Polishing
Grouting and Sealing

NEW MATERIALS

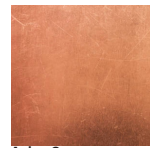

Aging Copper
Thresholds

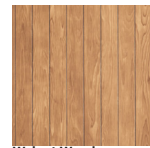

Walnut Wood
Furniture



Italian Beige
Hallways floor/walls



Dimmable glass
Facades

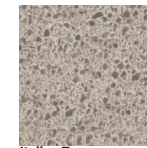

Italian Terrazzo
Hallway flooring
Recycled



Cast in Concrete
Monumental stairs
Structural floors
Recycled

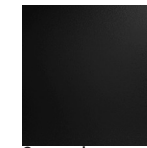

Opaque glass
Interior smart glass

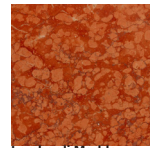

Lombardi Marble
Red custody

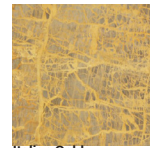

Italian Gold
Offices/public space

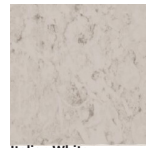

Italian White
Monumental walls



Lombardi Gray
Urban floors

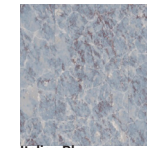

Italian Blue
Services floor

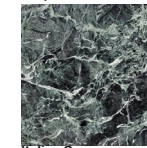

Italian Green
Communal spaces



Italian Black
Data center floors

REUSED

Room-within-a-Room or Tanking

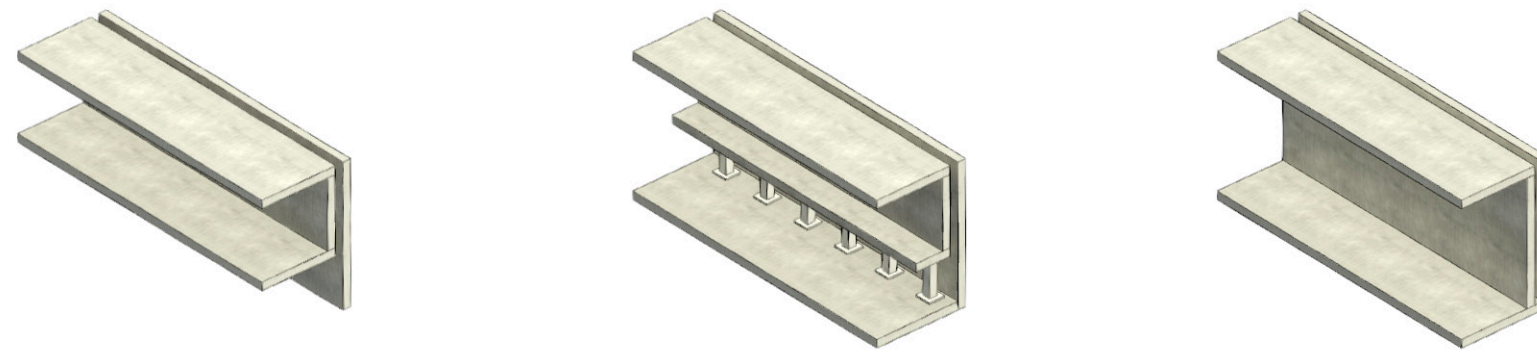

Footprint Area: 36,000 m²

Perimeter Diaphragm: Approximately 800 to 900 linear meters of external wall surface.

Cavity Gap Width: Typically 50mm to 100mm between the historic stone and the new structural lining.

Void Volume: A 100mm gap across the entire vertical perimeter (assuming 8m height) creates a 450 m³ air-buffer/drainage zone.

Drainage Capacity: At this scale, the system must be capable of diverting thousands of liters of “weeping” groundwater per hour to internal sumps.

Room-within-a-Room or Tanking

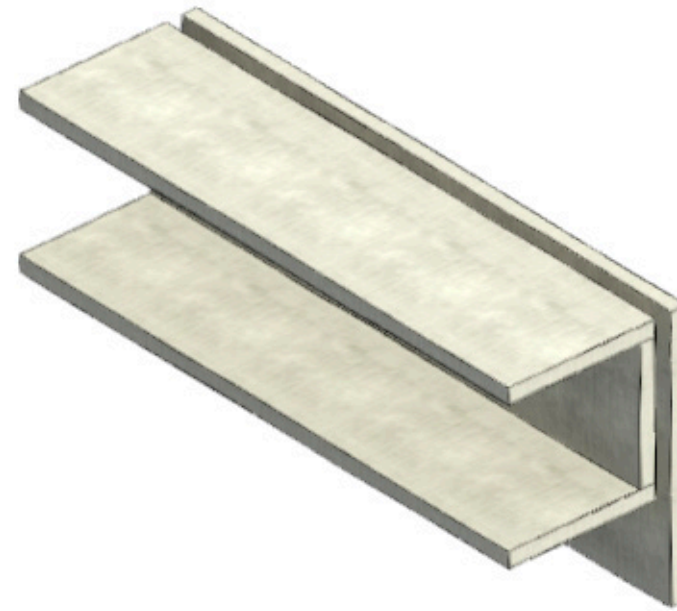

Preparation and Substrate Stabilization:
Survey and Mapping
Surface Debridement
Structural Grouting

Room-within-a-Room or Tanking

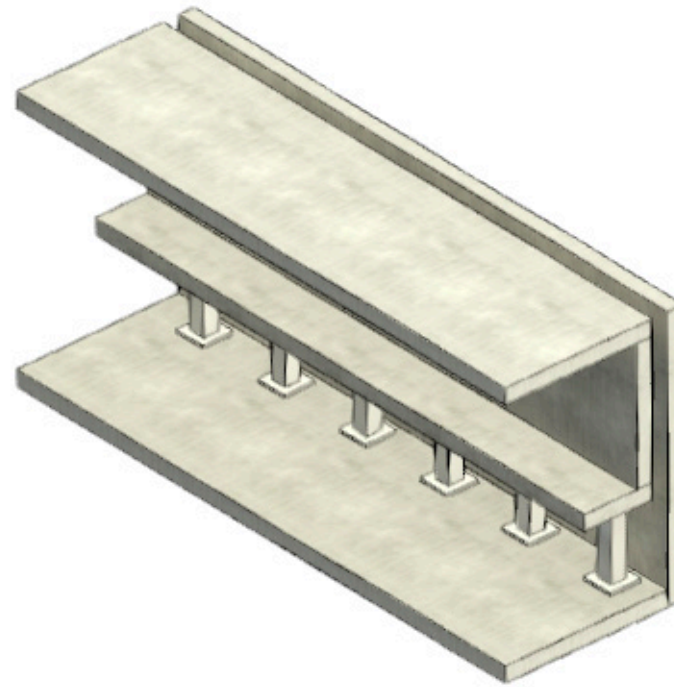

The Drainage Infrastructure (The "Chassis"):

- Perimeter Channeling
- Surface Debridement
- Sump Station Installation
- Conduit Layout
- Wall Membrane Fixity
- Floor Membrane Overlay

Room-within-a-Room or Tanking

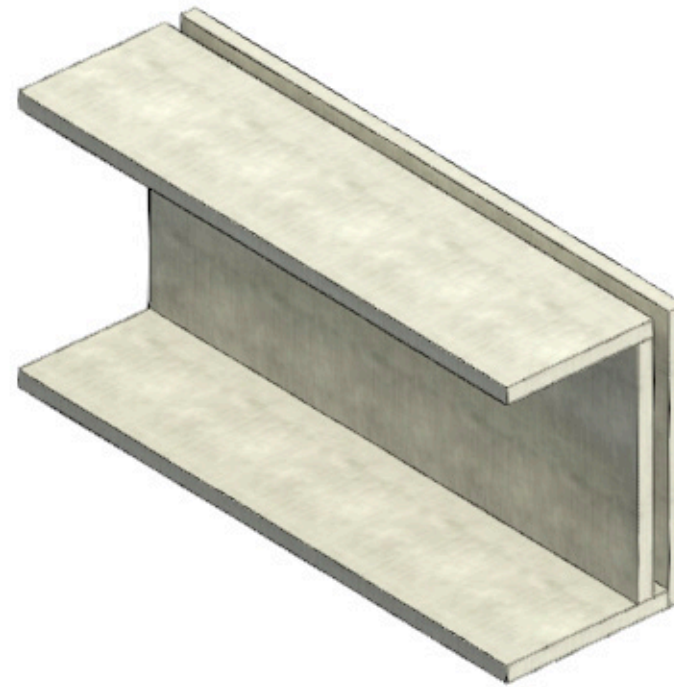

Structural Interior Lining (The "Slim" Layer):
Reinforcement Placement
The Slim Floor Pour
Internal Wall Construction

STRUCTURAL ASSEMBLY

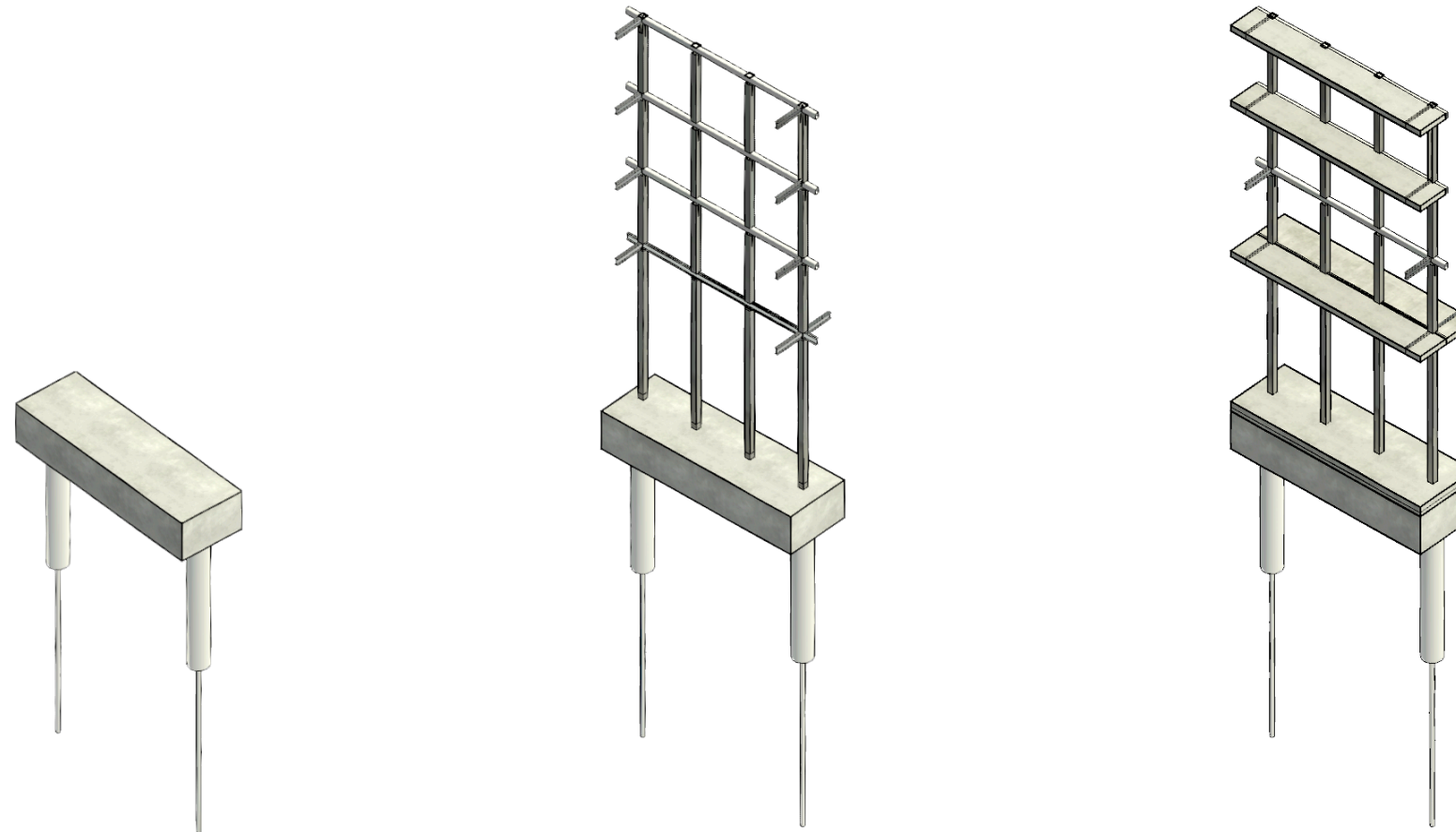

Total Annual Energy to Offset: 1,057,000 kWh
Borehole Count: Approximately 295 to 310 boreholes.
Drilling Depth: 150 meters per borehole to reach stable subterranean temperatures.
Borehole Diameter: 150 mm.
Total Drilling Length: 44,250 linear meters.
Extraction Yield: Approximately 3.5 to 4 kW per borehole based on 1,800 running hours per year.

STRUCTURAL ASSEMBLY

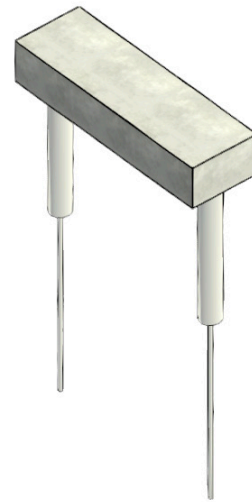

Borehole Drilling:
Positioning
Excavation
Stabilization

STRUCTURAL ASSEMBLY

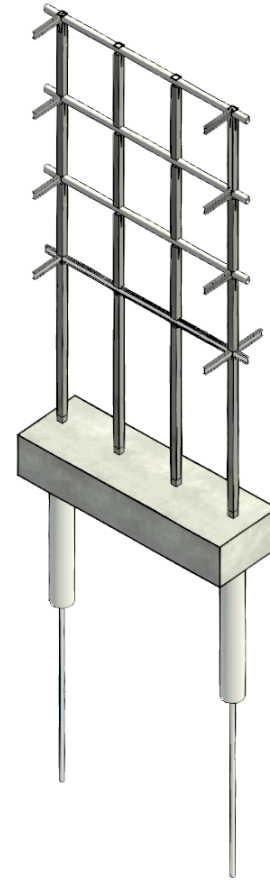

-
- Fabrication of the Geothermal "Steel Skeleton":
 - Steel Cage Assembly
 - Loop Attachment
 - Circuit Headers
 - Pressure Test (Pre-Installation)
 - Lowering the Cage

STRUCTURAL ASSEMBLY

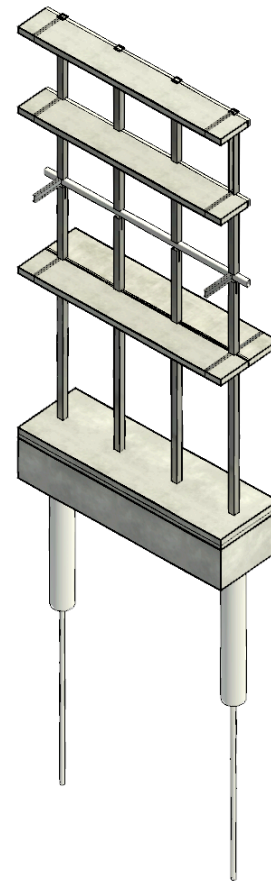

-
- Concreting (The Thermal Mass):
 - Tremie Pipe Setup
 - The Pour
 - Maintaining Pressure:
 - Final Pressure Test
 - Headering
 - System Connection

FACADE ASSEMBLY

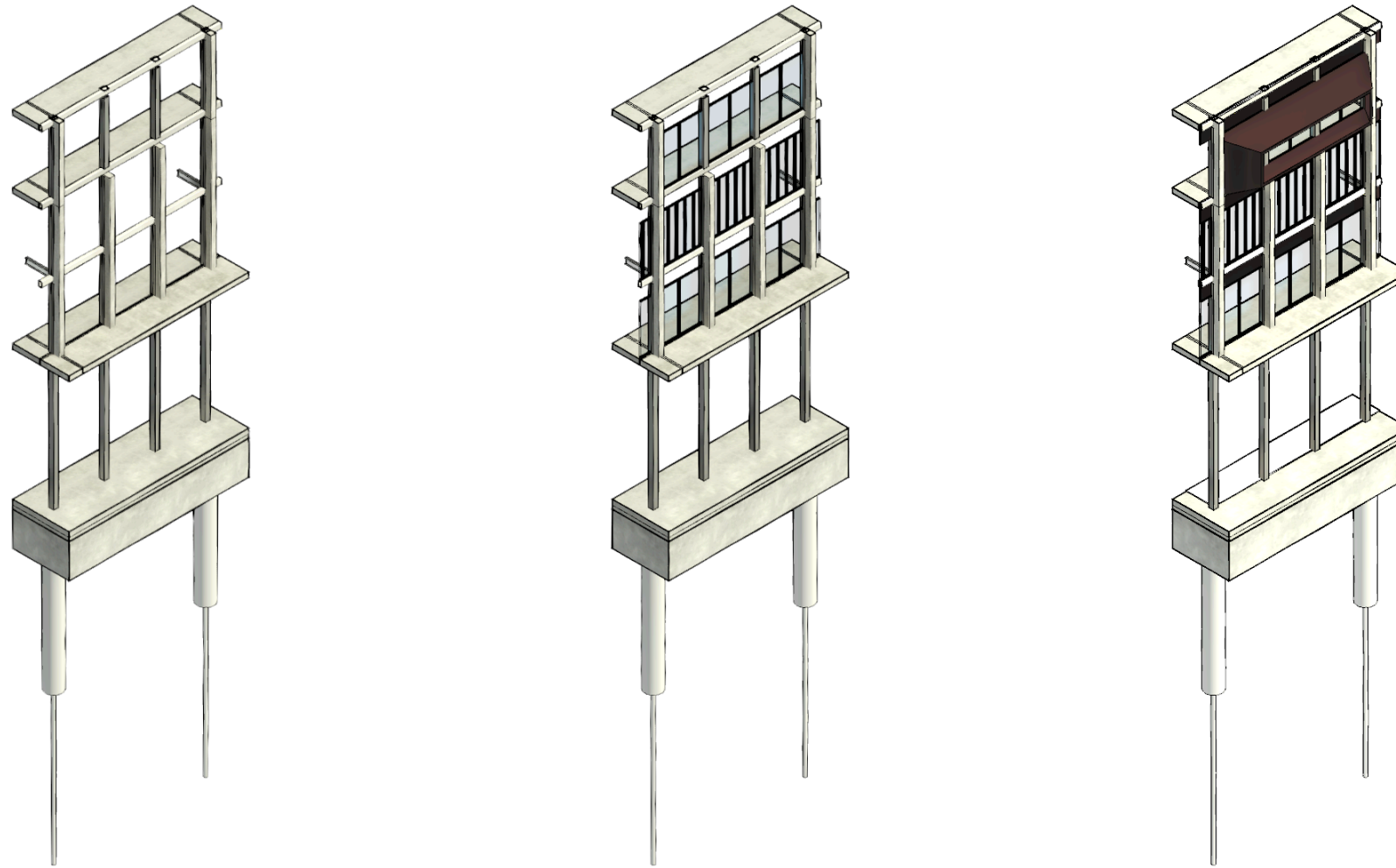

HOLLOW COLUMNS/CURTAIN WALLS/SPANDRELS+FRAMES

INTERIOR FINISHING

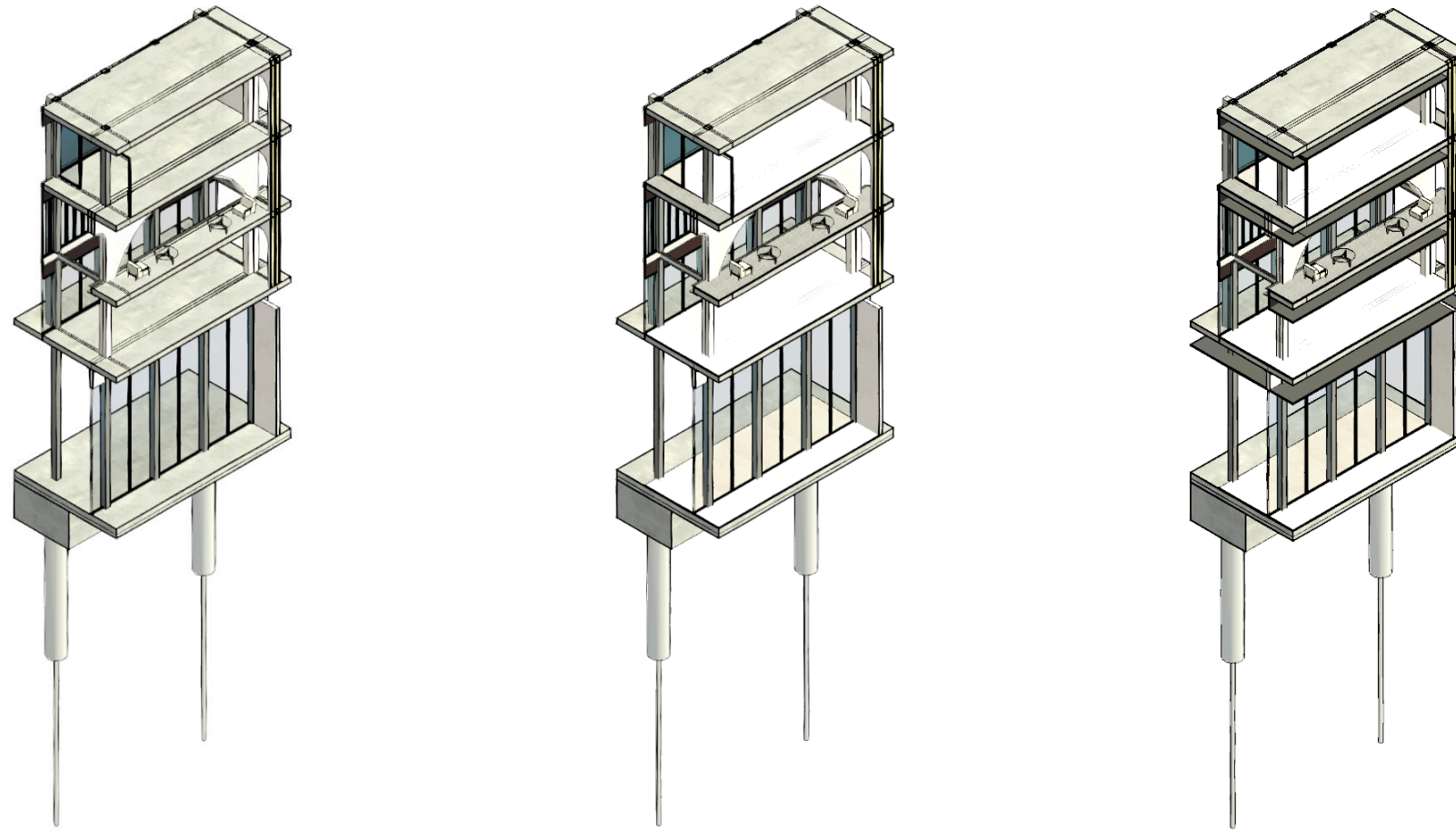

INTERIOR WALLS/FLOORS/SUSPENDED CEILING

The Hallway Buffer: The 3-Meter Buffer Hallway (Thermal Strategy)

Thermal Buffer: In winter, it acts as a "greenhouse" to pre-heat air before it enters the courtrooms. In summer, it prevents direct solar radiation from hitting the inner glass, reducing the "Greenhouse Effect."

Smart Glass Synergy: Since using smart glass on the facade, you can set it to "Matt" mode on the sunny side of the building to block heat, while keeping it transparent on the shaded side to maintain the "Transparency of Justice" aesthetic.

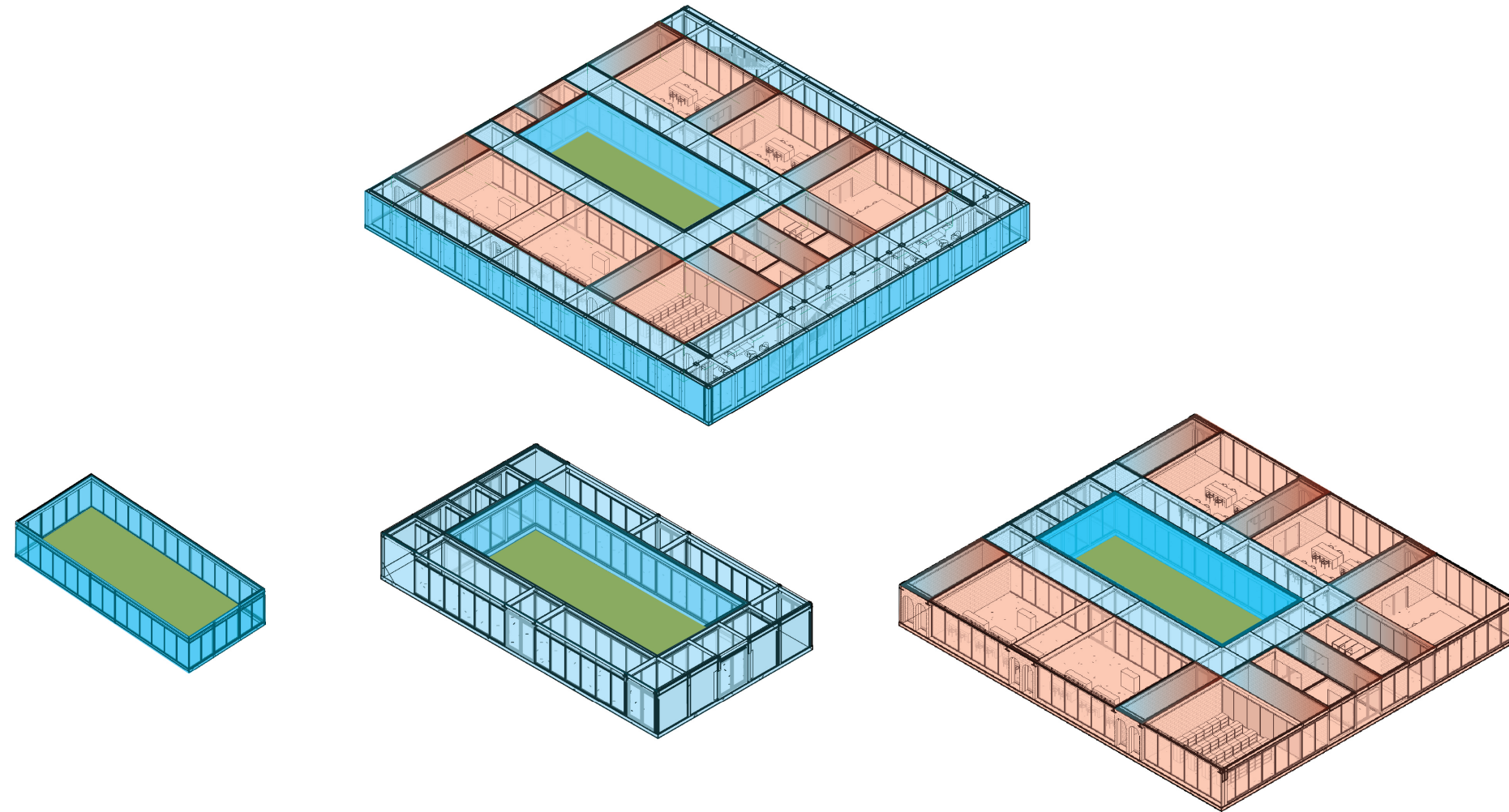

The Courtyards: Using the central courtyards, cooling the building's thermal mass for the next day.

Interior Hallway Buffer: This space is the most valuable passive tool. It should act as a "thermal lung," inhaling cool air from the courtyards at night and exhaling heat through the louvers during the day.

Data Center Heat Recovery: Instead of venting it, this heat is "pumped" into the building's domestic hot water or used to pre-heat the central courtroom volumes via the 3-meter buffer hallway.

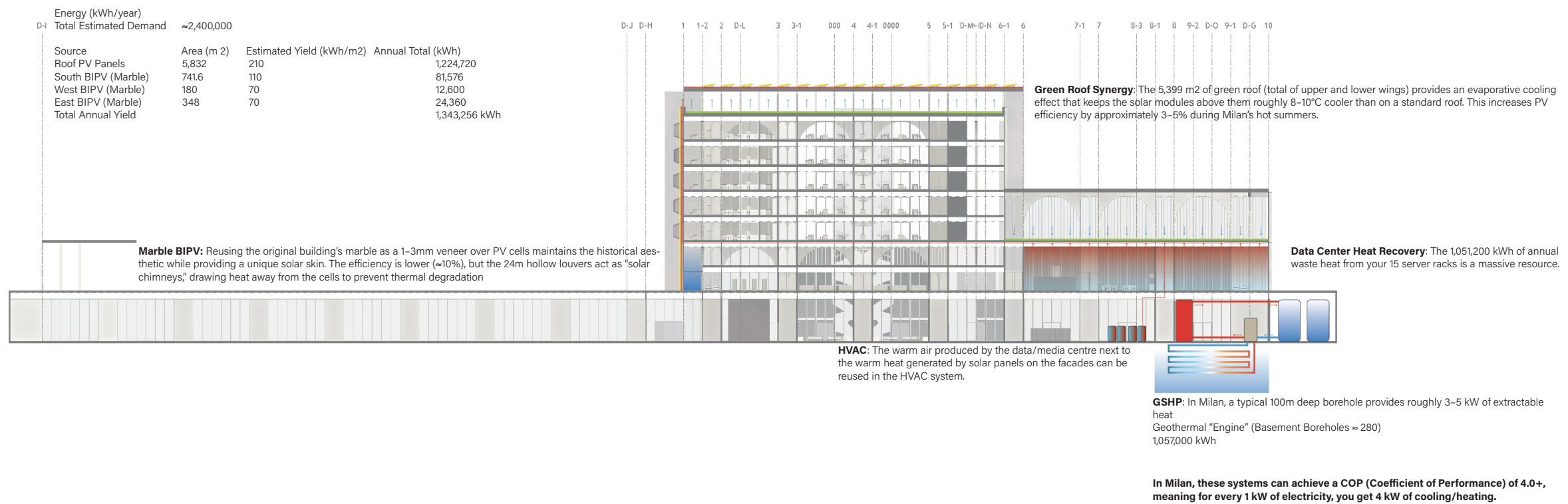

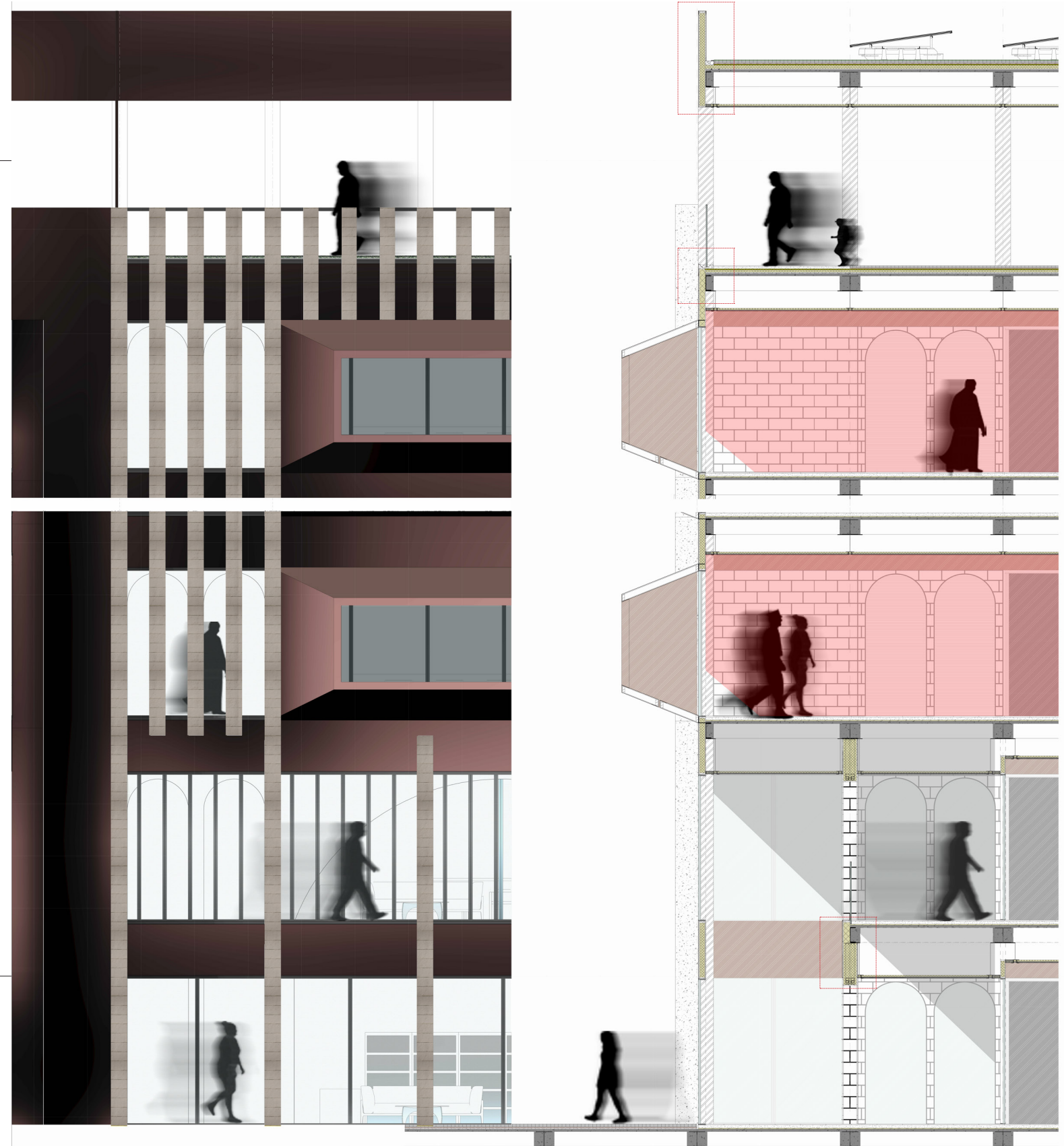

DETAILS 1:5

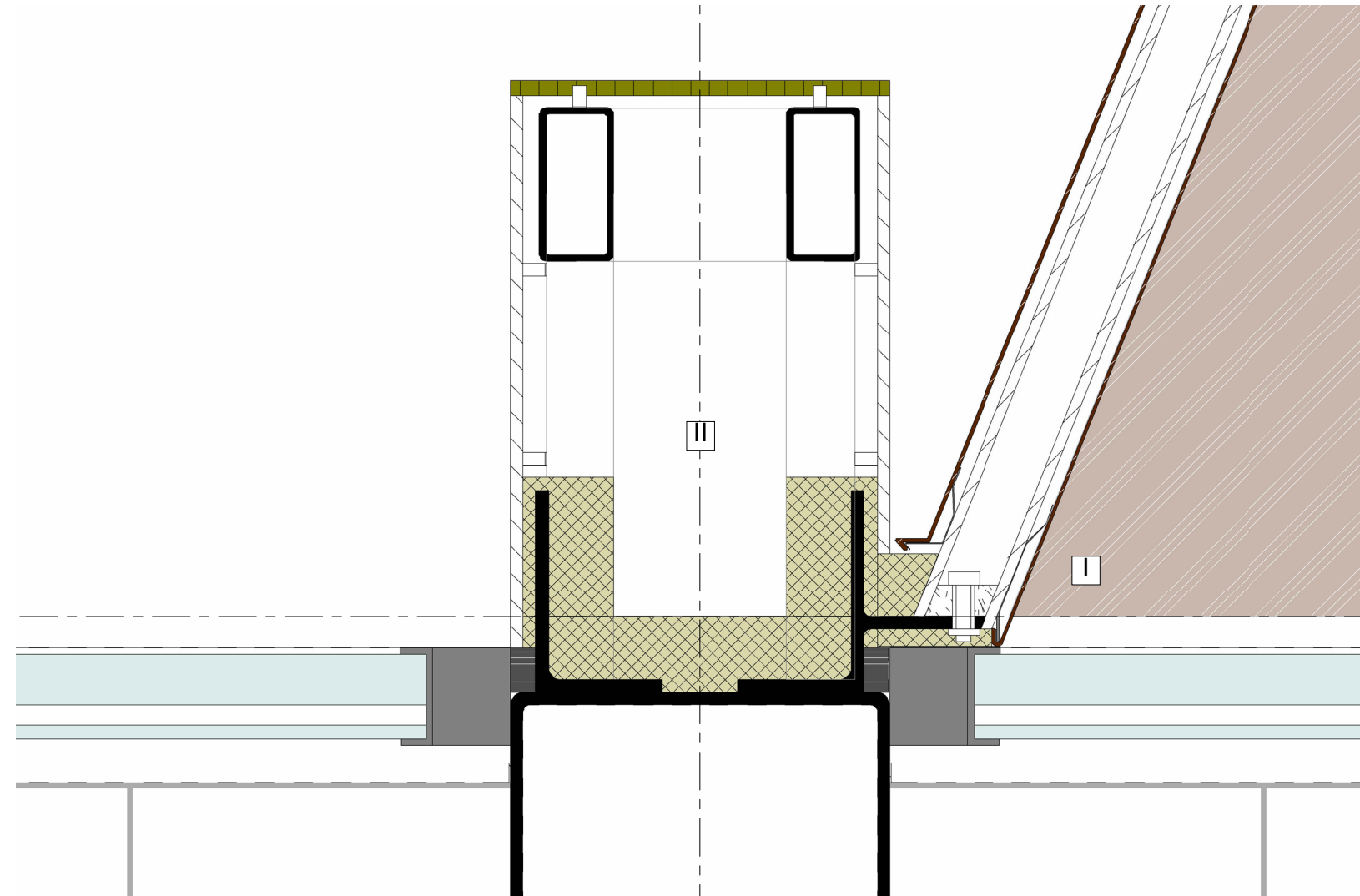

I. Frame Package:

Copper aging plate 3 mm folded structure around the wood framing, attach with L bracket to hollow column with screw space for copper expansion
30mm drainage in the center lower edge

II. Solar Package:

Aluminum structure hollow column attached SHS 300x300x10 structural column
BIPV concrete effect solar panels attached to the extended face
Mineral wool thermal around L bracket fire resistance coated
Recycled concrete tiles on the edges

DETAILS 1:5

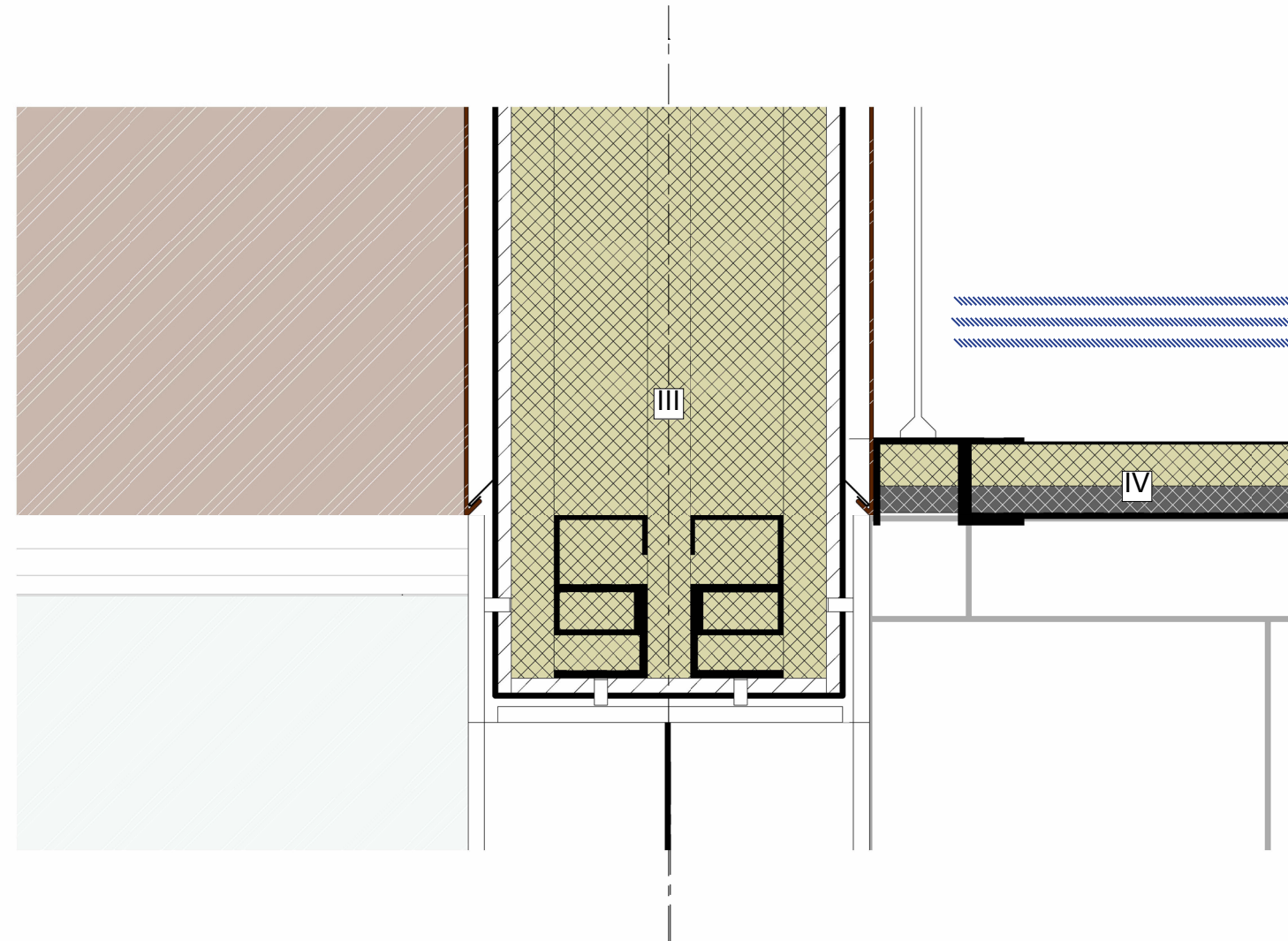

III. Marble wall Package:

- Marble panels 12 mm (both sides)
- Open shadow joints 8–12 mm (acoustically open; no sealant)
- Ventilated acoustic cavity 25 mm (both sides)
- Black non-combustible scrim (glass-fiber) (both sides)
- Mineral wool absorber 50 mm (40–60 kg/m²) (both sides)

DIY structural core (acoustic stud wall)

- Double steel stud system (decoupled)
- Steel studs 70 mm + 70 mm, back-to-back but not touching
- Separation gap between stud rows: 20 mm
- Mineral wool infill inside stud zones

IV. Ceiling Package:

- Copper mesh cassette (3×3 m)
- Black non-combustible scrim
- Perforated metal tray (open area ~15–30%)
- Mineral wool 80–100 mm (40–60 kg/m²)
- Air gap 200–300 mm (plenum)
- Services zone above

DETAILS 1:5

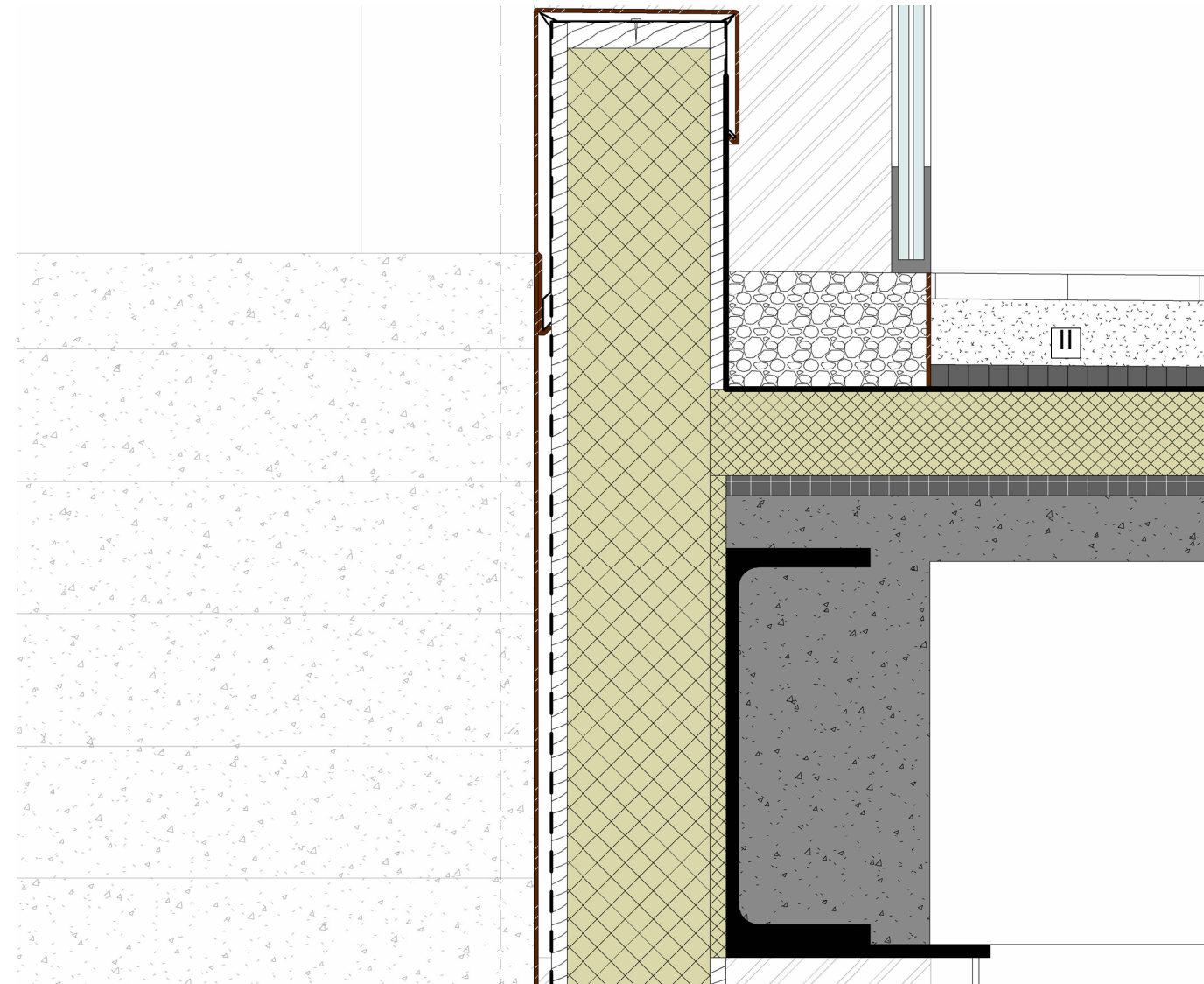

II. Floor Package:

- Slim floor (IFB 300 + IPE 300) with recycled marble / terrazzo finish
- Recycled marble or marble terrazzo tiles 20 mm
- Stone adhesive 3-5 mm
- Uncoupling / separation membrane
- Floating screed 60 mm (reinforced)
- Drainage and water grid 30mm
- PE roofing layer
- Resilient acoustic/thermal layer 15-20 mm (Vibration purpose)
- Slim floor structural slab on IFB 300 main beams + IPE 300 secondary beams

DETAILS 1:5

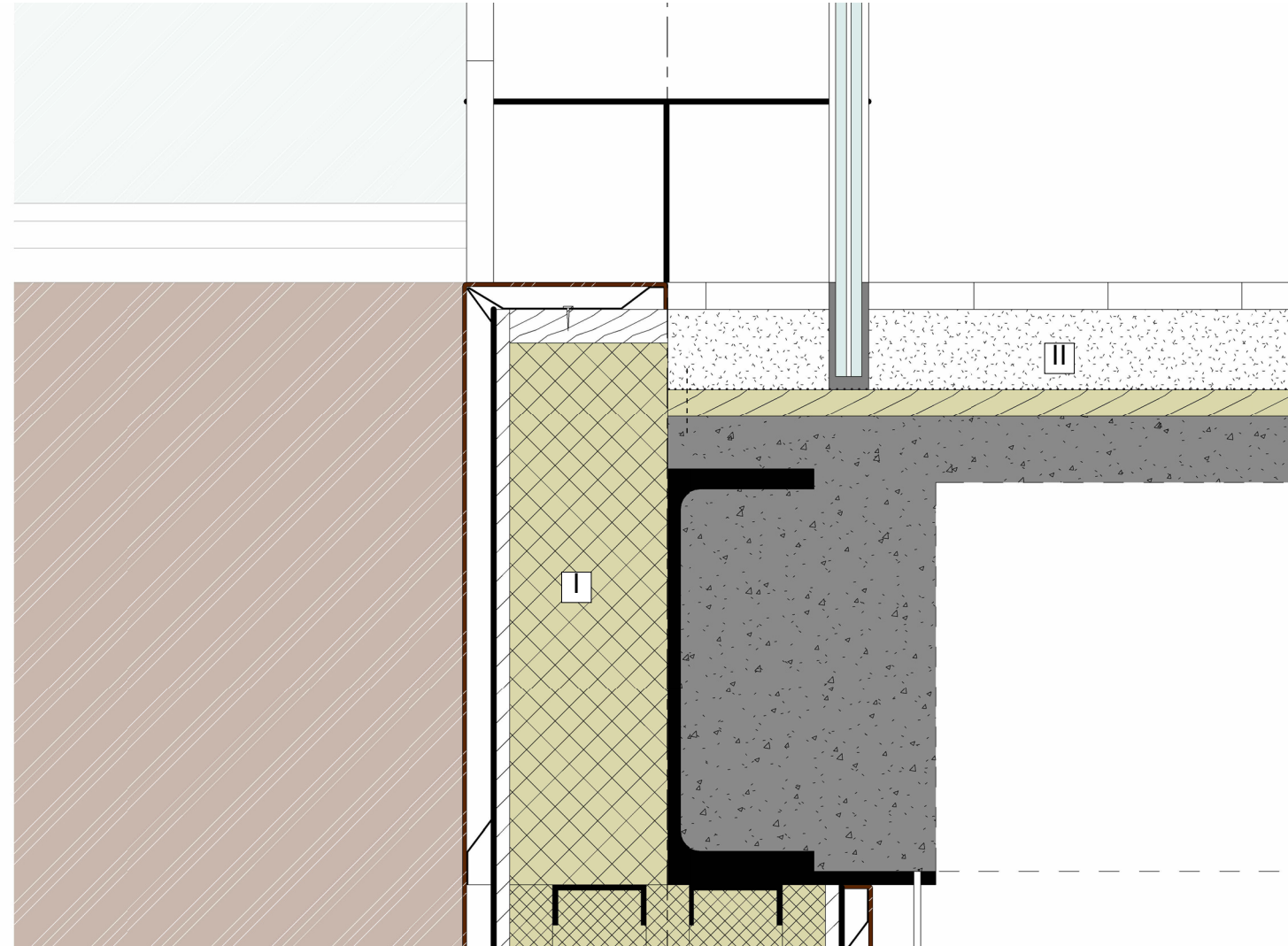

I. Spandrels Package:

- Inter-floor Thermal Spandrels Package (≤ 145 mm)
- Copper finish panel 3–4 mm
- Ventilated cavity 10–15 mm
- Breather membrane
- Thermal insulation 80–90 mm (mineral wool or PIR)
- Airtight / vapor control layer
- Fire-rated backing board 10–12 mm
- Thermally broken fixing system to slab / frame

II. Floor Package:

- Slim floor (IFB 300 + IPE 300) with recycled marble / terrazzo finish
- Recycled marble or marble terrazzo tiles 20 mm
- Stone adhesive 3–5 mm
- Uncoupling / separation membrane
- Floating screed 60 mm (reinforced)
- PE slip foil
- Resilient acoustic/thermal layer Wood Fiber 15–20 mm (load-bearing)
- Slim floor structural slab on IFB 300 main beams + IPE 300 secondary beams

DETAILS 1:5

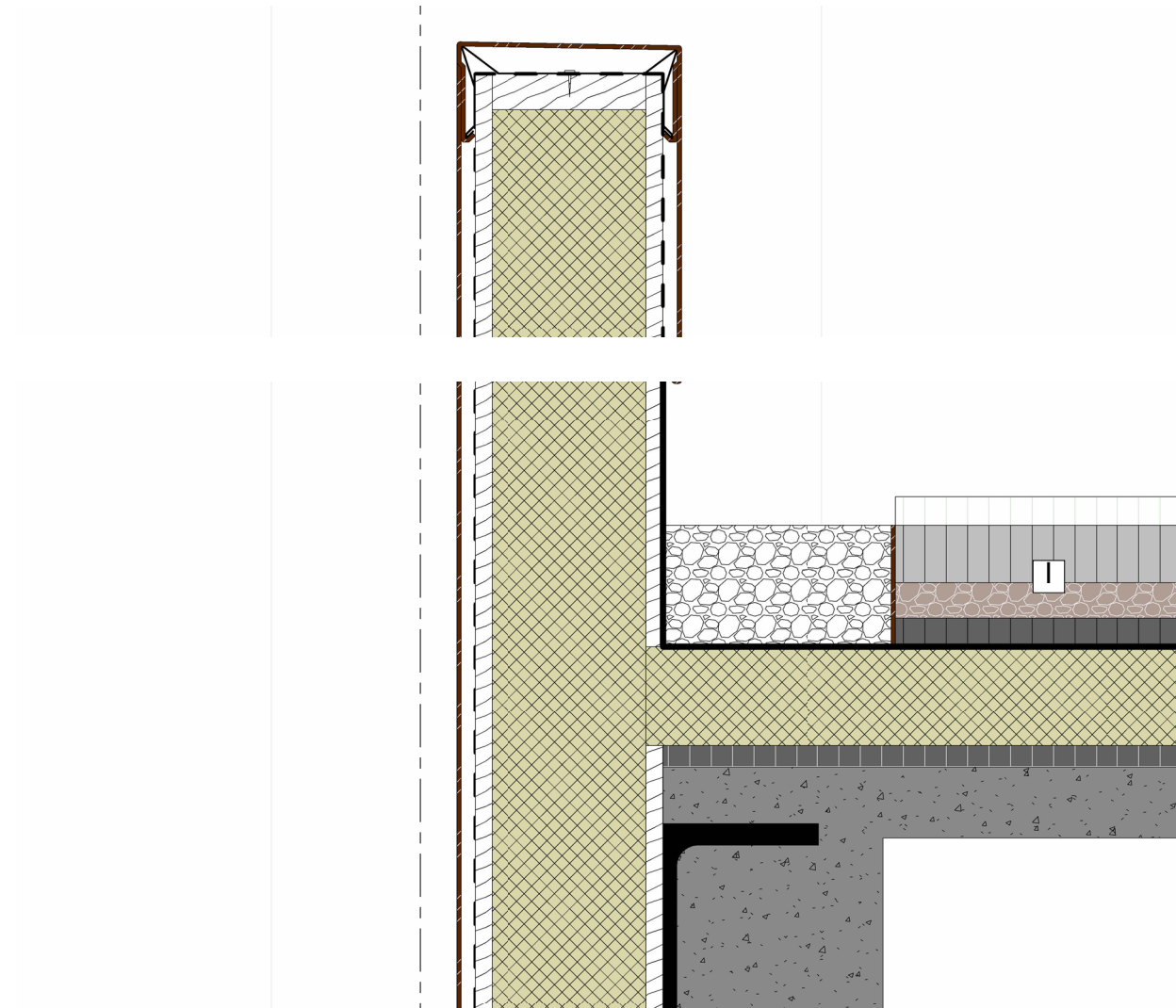
**I. Green Floor Package:**

Water-absorbing green layer (100 mm) on slim floor (IFB 300 + IPE 300)

Vegetation / green surface layer (sedum / planted finish)

Filter fleece (geotextile)

Gravel grid / water retention layer 60 mm (load-bearing, water-storing)

Aggregated bedding layer 25 mm (washed gravel / drainage aggregate)

Thermal Insulation (XPS) 50mm

Waterproofing membrane (root-resistant)

Slip / separation layer

Resilient acoustic/thermal Rubber layer 15 mm (load-bearing)

Slim floor structural slab on IFB 300 main beams + IPE 300 secondary beams

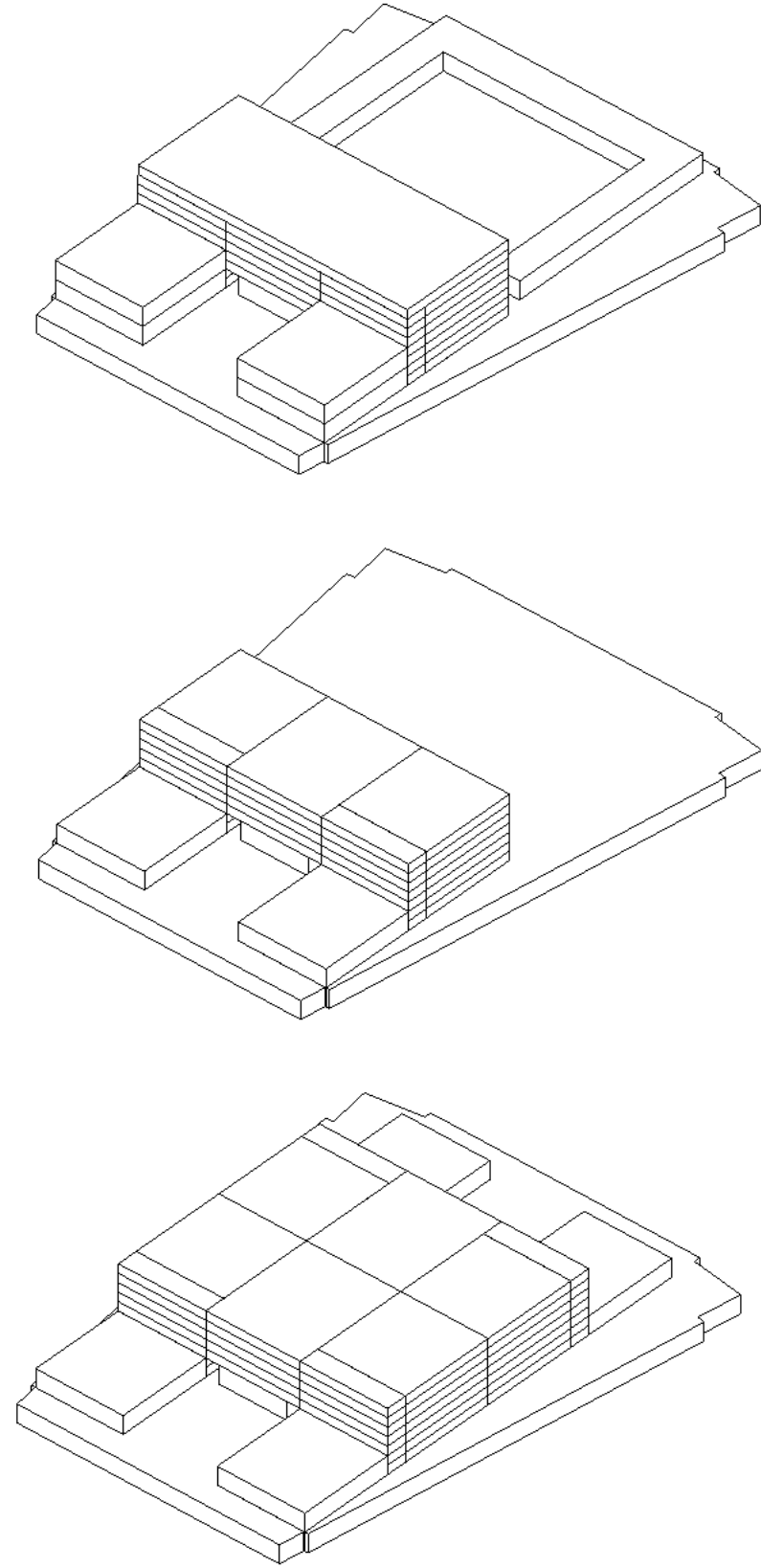

POSSIBLE FUTURE THRESHOLD

UNPREDICTABILITY

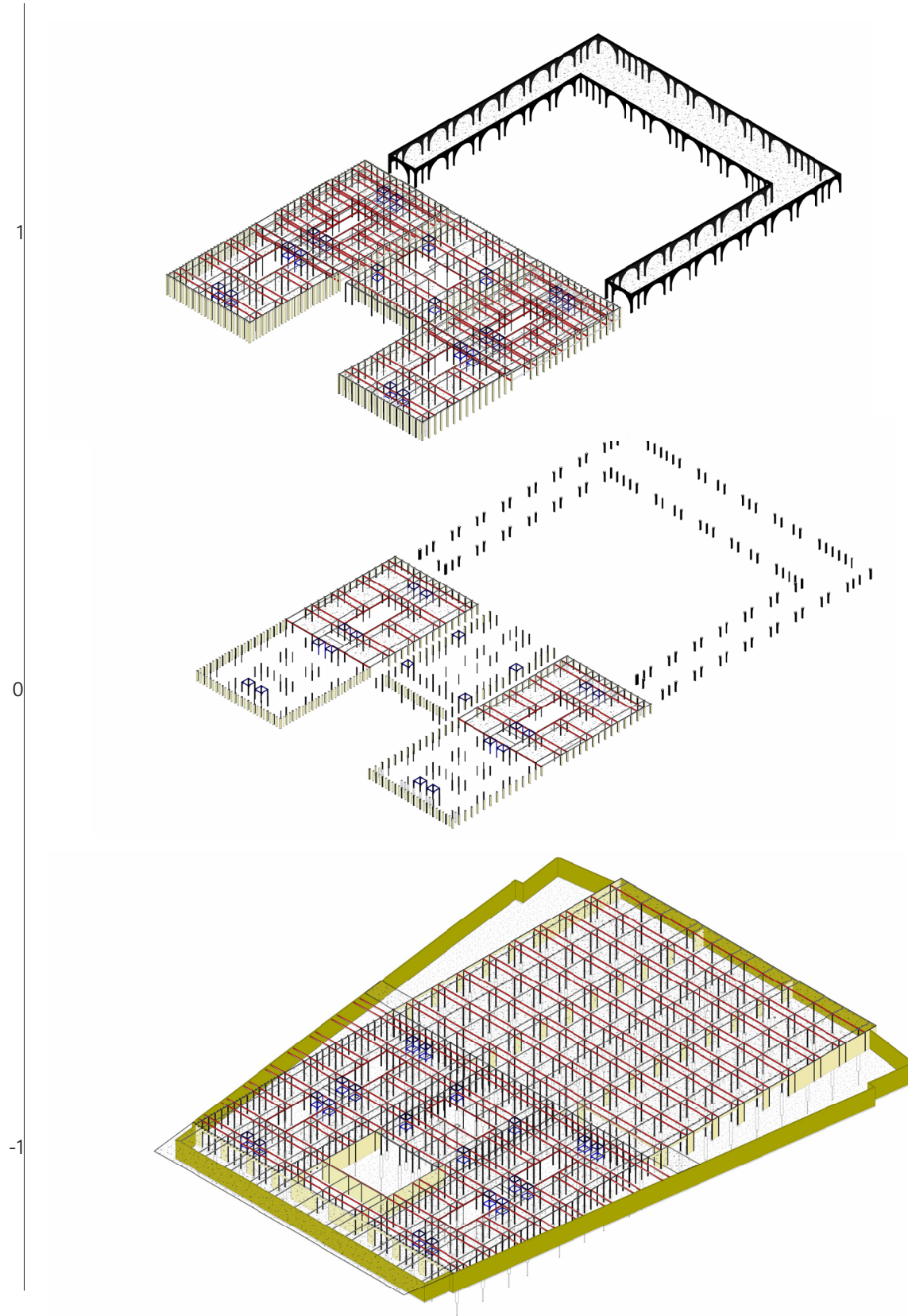

- **Primary Structure/Courtyard Edge**
IFB 300 bottom extension
- **Secondary Structure**
IPE 300
RHS-CF 250x150x8 Lifts
- Facade Support**
UPE 300
- **Columns/Structural concrete wall**
SHS CF 300x00x8
SHS CF 150x150 x8
- Foundation**
Mixture of existing
Concrete floor/Walls
+Piles/Caps/Energy Piles
- **Lift**
Inner "Box in Box" structure
Wind catchers
- **Hollow Columns**
Aluminum structure
Facade elements
Wind and solar force
- **Existing concrete walls**

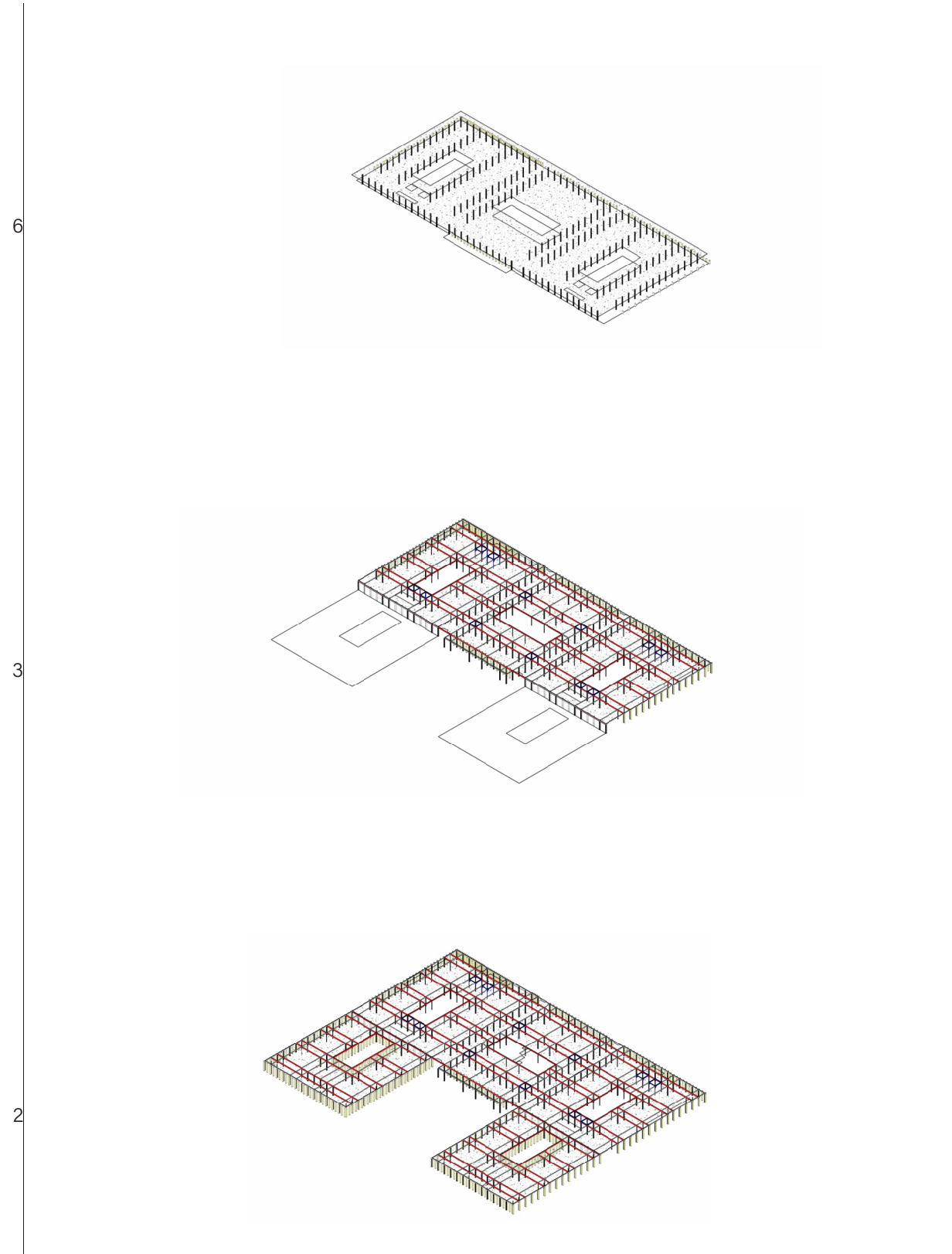

- **Primary Structure/Courtyard Edge**
IFB 300 bottom extension
- **Secondary Structure**
IPE 300
RHS-CF 250x150x8 Lifts
- Facade Support**
UPE 300
- **Columns/Structural concrete wall**
SHS CF 300x00x8
SHS CF 150x150 x8
- Foundation**
Mixture of existing
Concrete floor/Walls
+Piles/Caps/Energy Piles
- **Lift**
Inner "Box in Box" structure
Wind catchers
- **Hollow Columns**
Aluminum structure
Facade elements
Wind and solar force
- **Existing concrete walls**

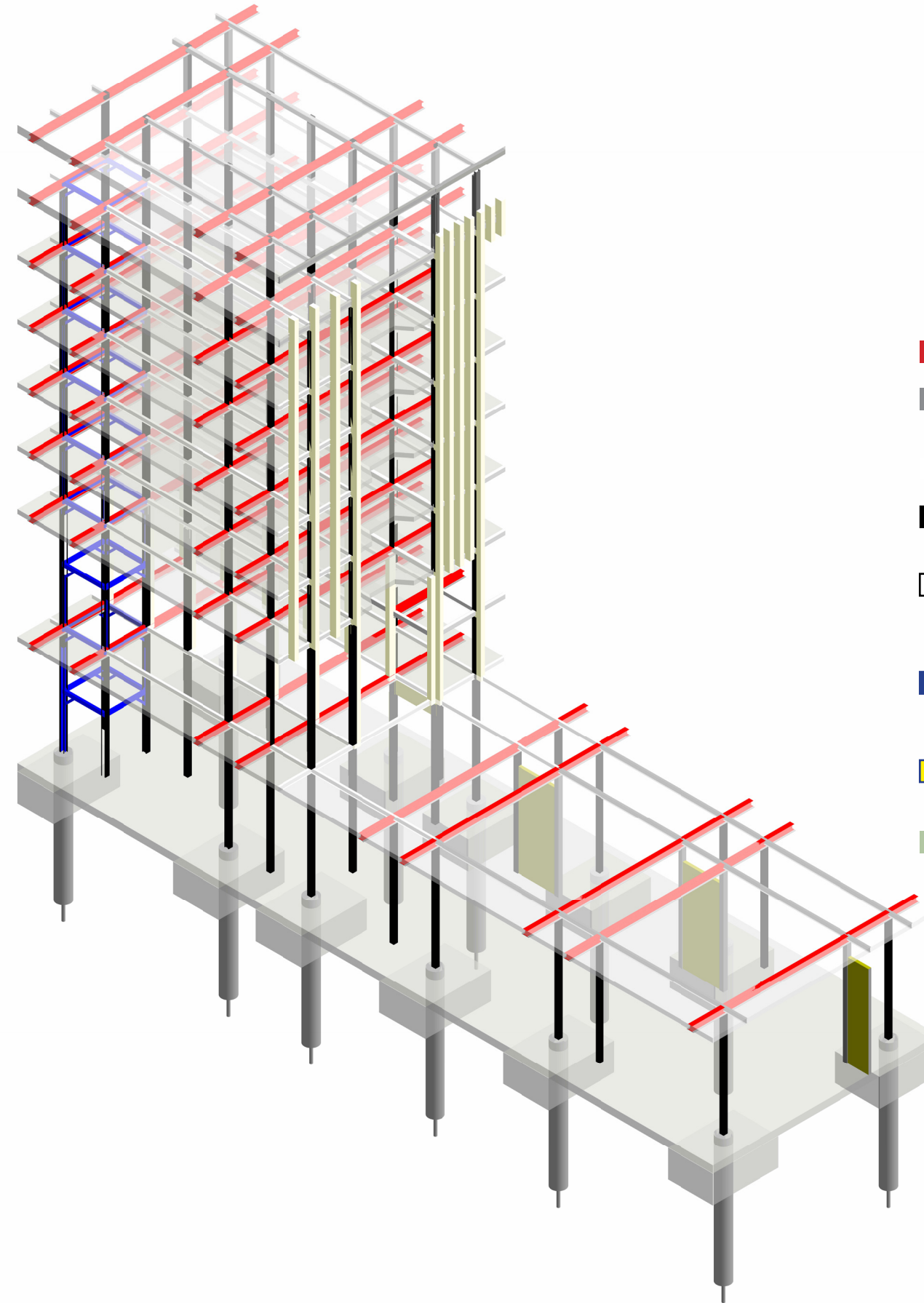

- **Primary Structure**
IFB 300 bottom extension
- **Secondary Structure**
IPE 300
RHS-CF 250x150x8 Lifts
- Facade Support**
UPE 300
- **Columns**
SHS CF 300x00x8
SHS CF 150x150 x8
- Foundation**
Mixture of existing
Concrete floor/Walls
+Piles/Energy Piles
- **Lift**
Inner structure
Box in Box
Wind catchers
- **Hollow Columns**
Solar aluminum structure
Facade elements
- **Existing concrete walls**



POWER OF THRESHOLDS

THANK YOU