

# Sustainability and Service Life of Curtain Walls

Stick and unitised system for short-term and long-term use in curtain walls

Mentors: Dipl.ing. Tillmann Klein  
Dr.ir. Fred Veer

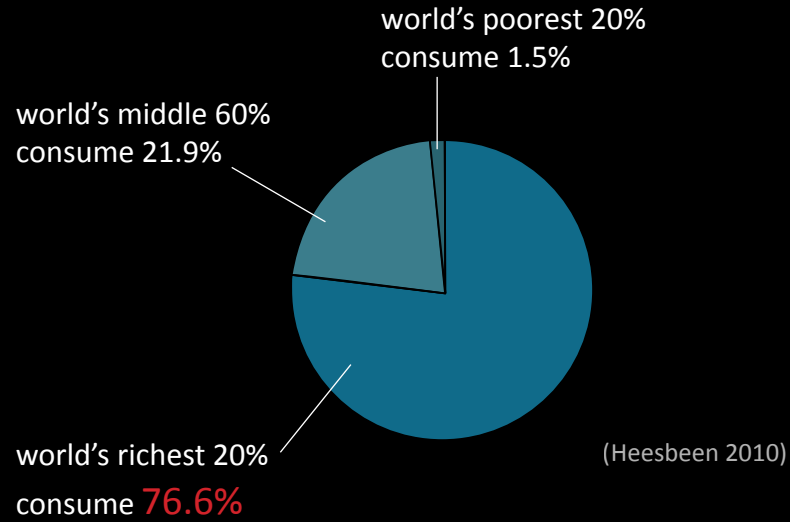

## References

Heesbeen, C. (2010). Materializing the life cycle of the facade. MSc, Tu Delft, Delft University of Technology.

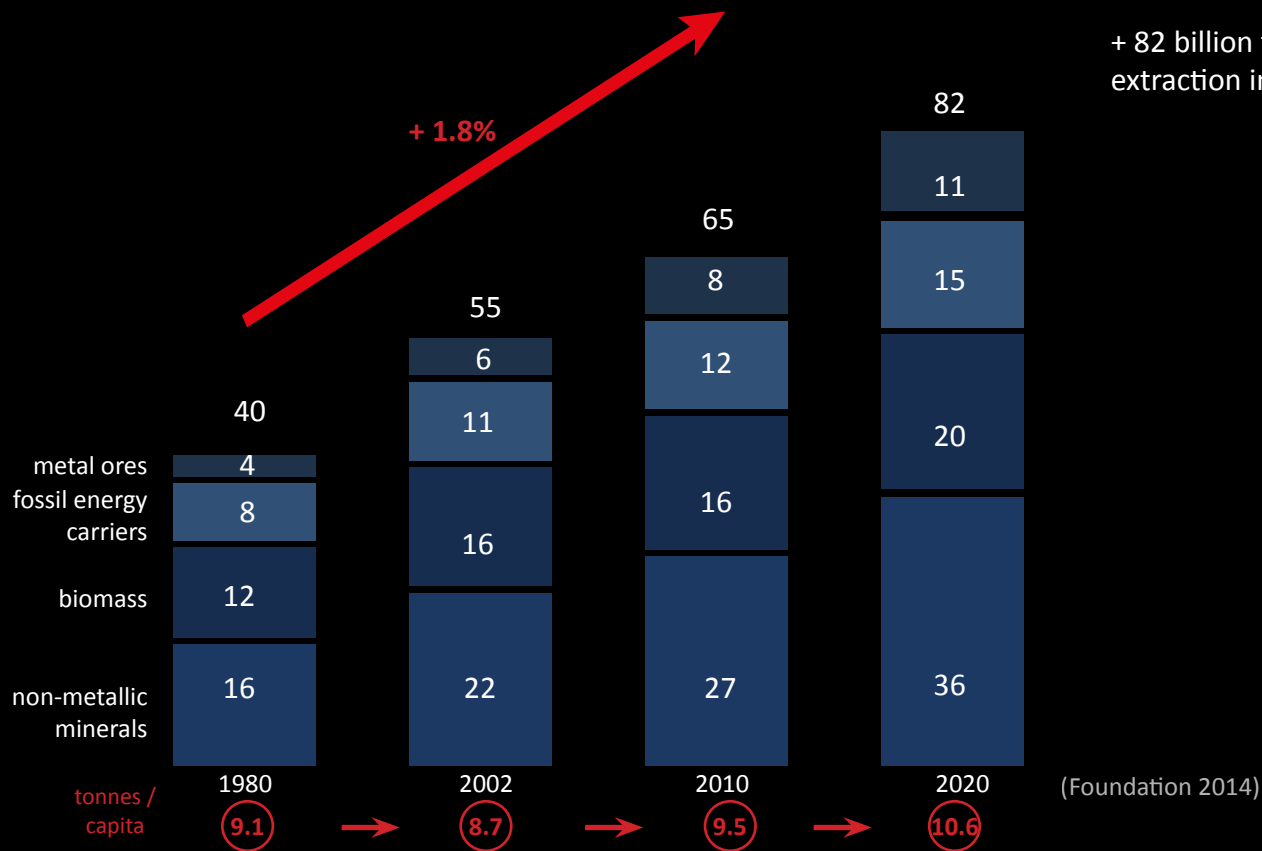

## References

Foundation, E. M. (2014). 'Towards the Circular Economy - Economic and business rationale for an accelerated transition', Ellen Macarthur Foundation.

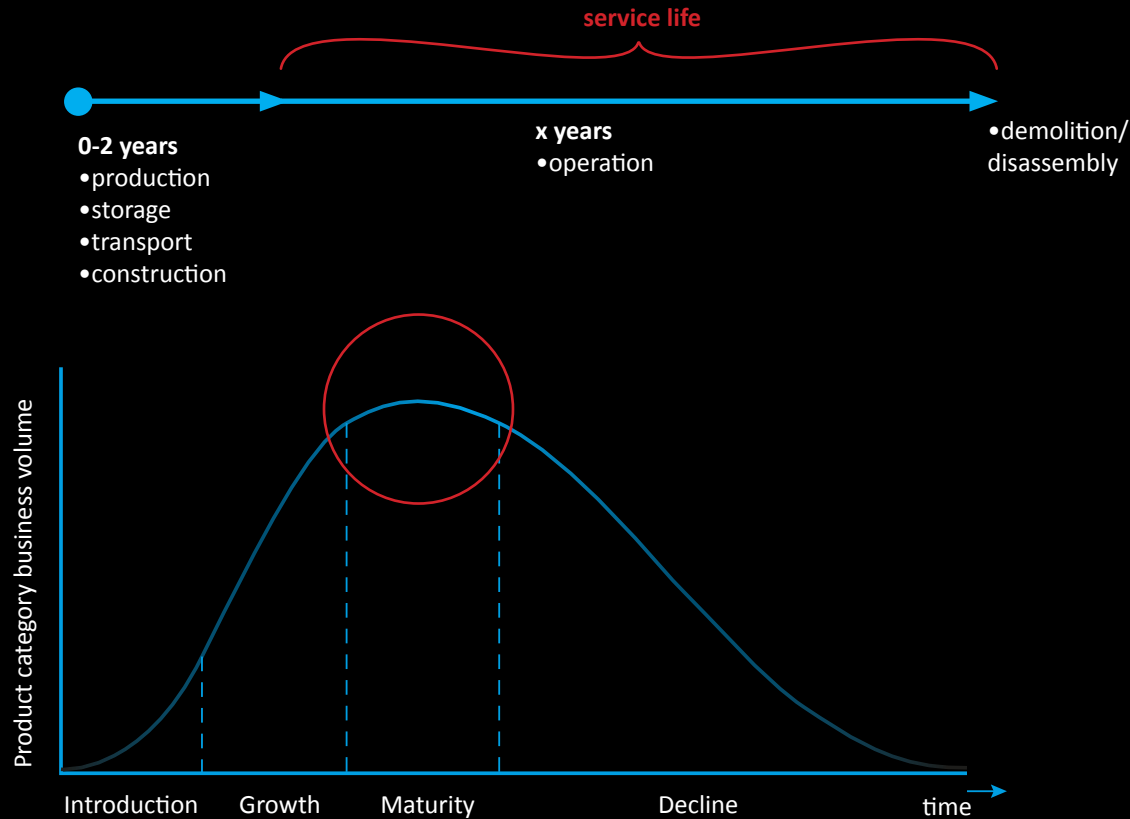

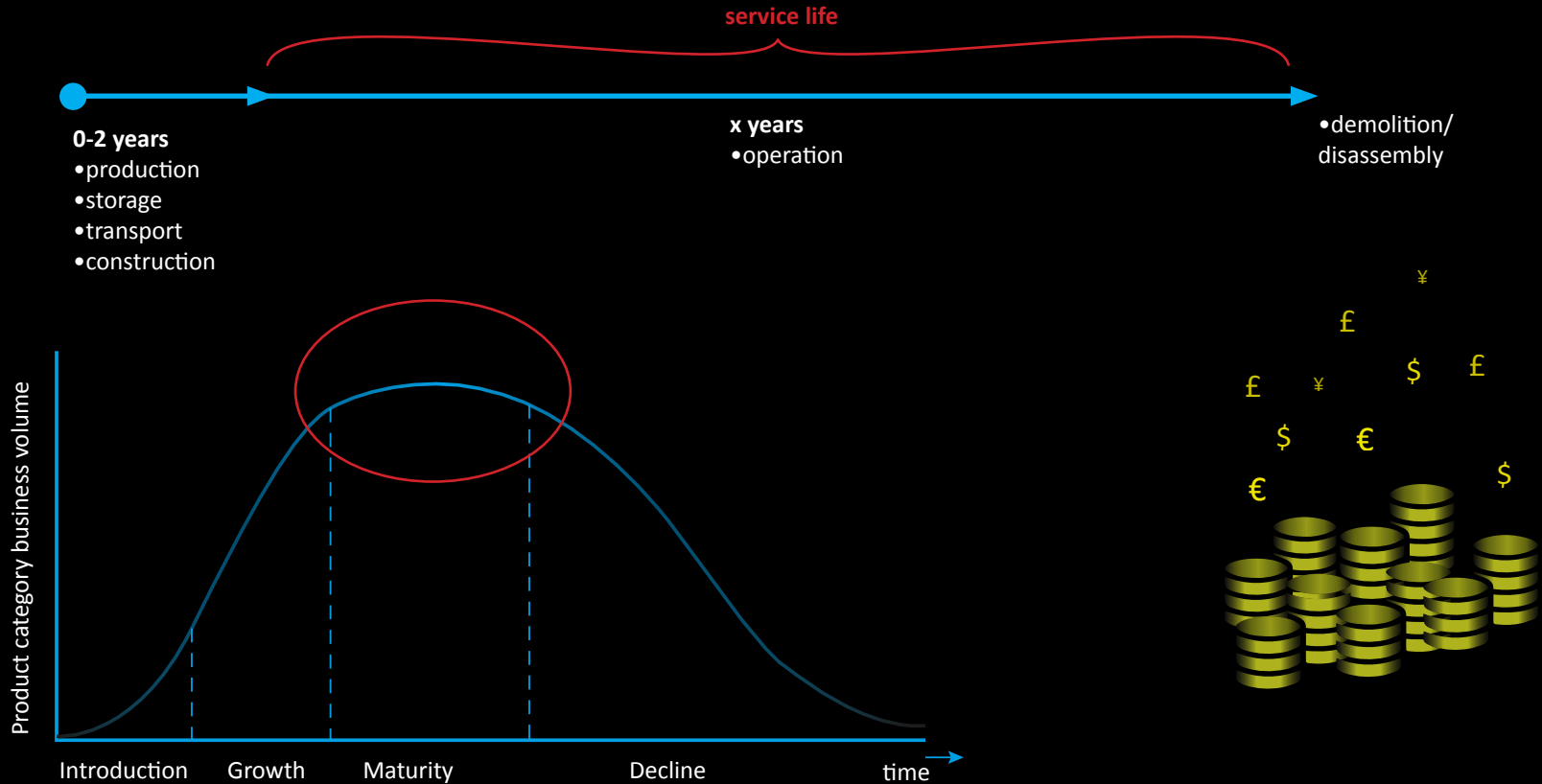

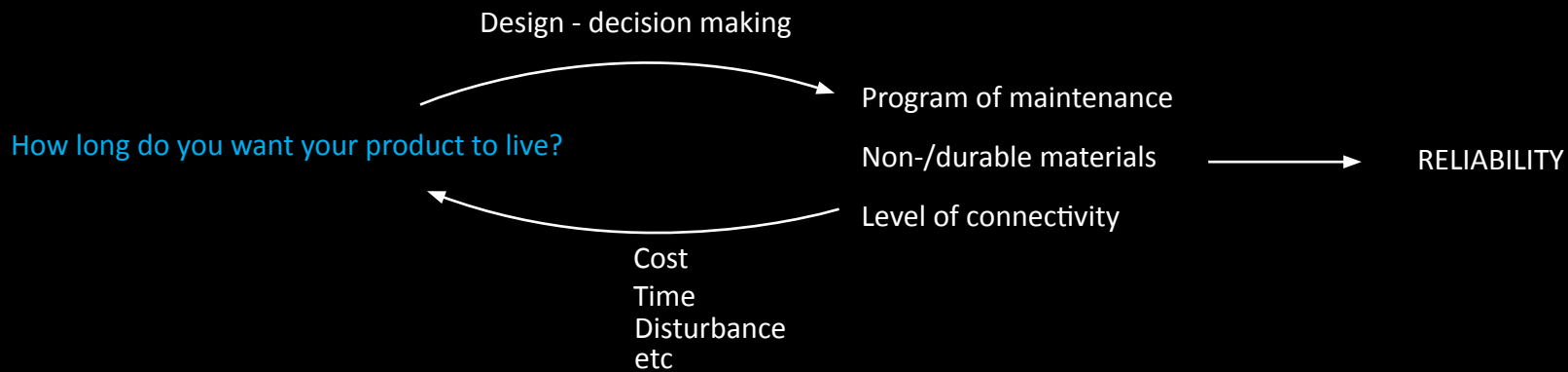



## Problem statement

Proportion between materialisation and operation of a construction must be in balance for a sustainable life cycle

Low energy buildings have already reduced the operational energy demands

Minimise environmental impact of materialisation

Rethink the role of product's expected life span

Starting point: curtain walls (widely used in office and commercial buildings)

Design phase → Decision making → Sustainability & Environmental Impact

## Problem statement

Proportion between materialisation and operation of a construction must be in balance for a sustainable life cycle

Low energy buildings have already reduced the operational energy demands

Minimise environmental impact of materialisation

Rethink the role of product's expected life span

Starting point: curtain walls (widely used in office and commercial buildings)

Product's  
service life



Design phase



Decision making



Sustainability & Environmental Impact



Materialisation

Operation

## Research question

- How long should a curtain wall live to have minimum environmental impact?
- Does stick or unitised curtain wall provide the most sustainable materialisation and service life?

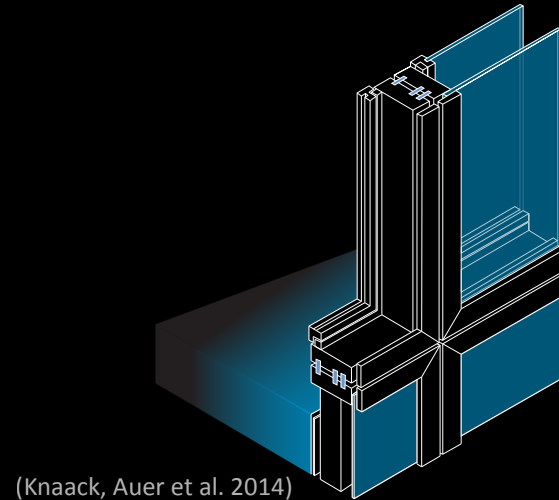
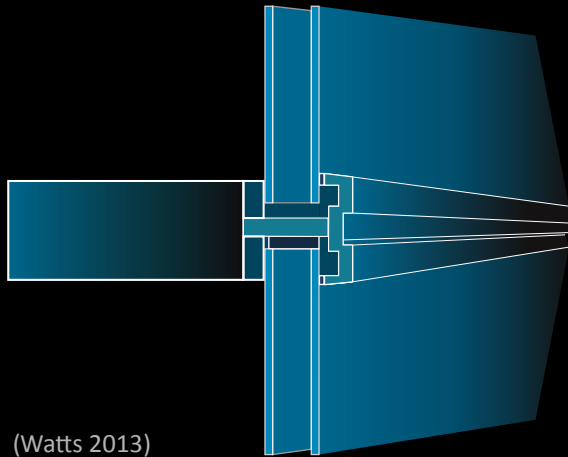

### References

Watts, A. (2013). Modern Construction Handbook. Berlin, Ambra.

Knaack, U., T. Auer, M. Bilow and T. Klein (2014). Façades; Principles of Construction. Basel, Switzerland, Birkhäuser.

## Research question

- How long should a curtain wall live to have minimum environmental impact?
- Does **stick or unitised** curtain wall provide the most sustainable materialisation and service life?

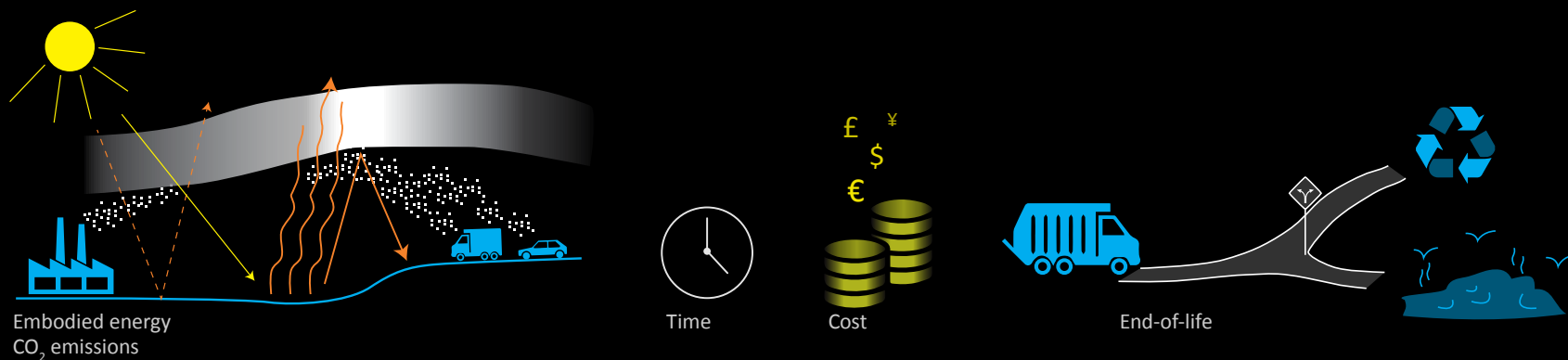

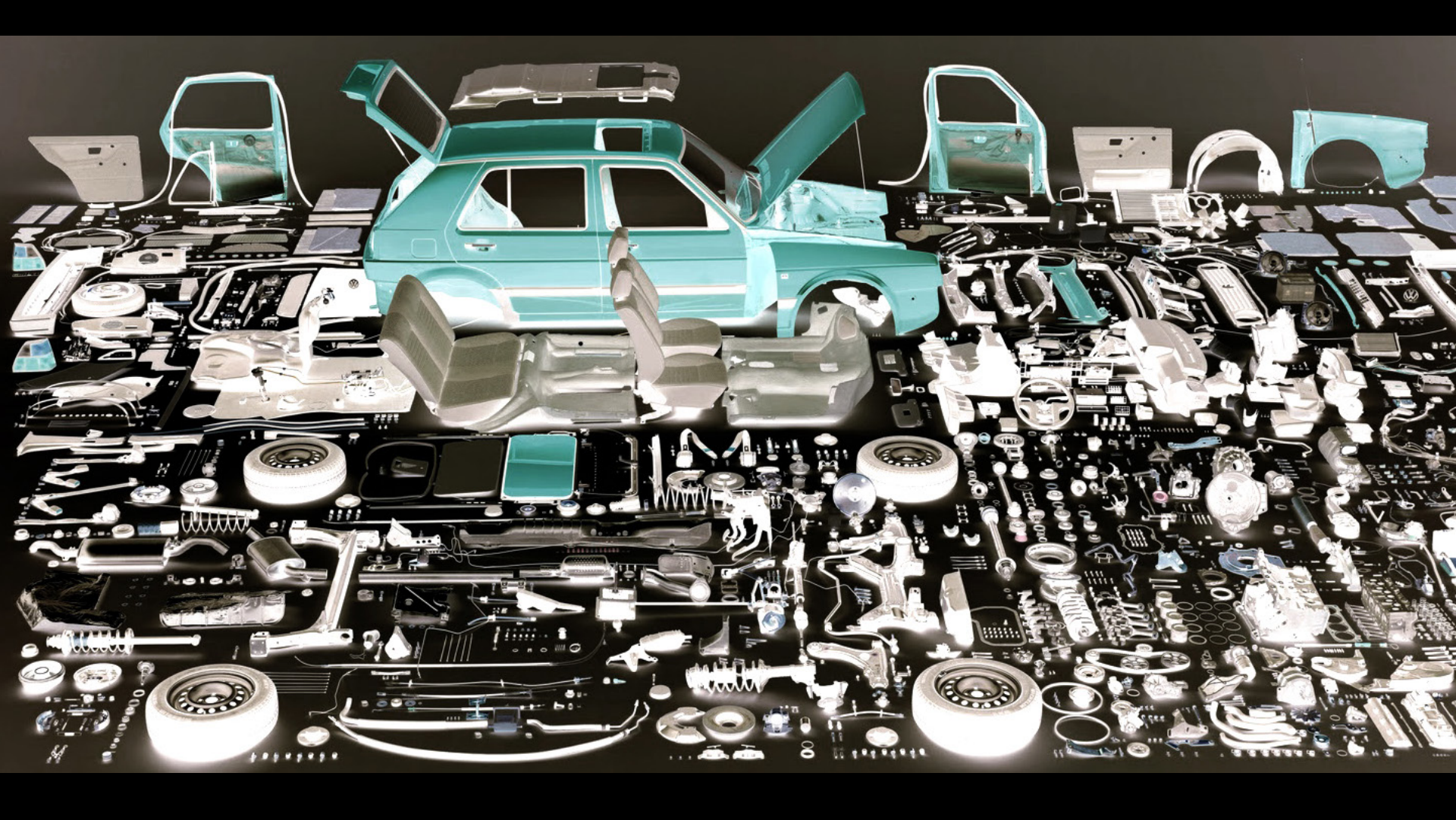

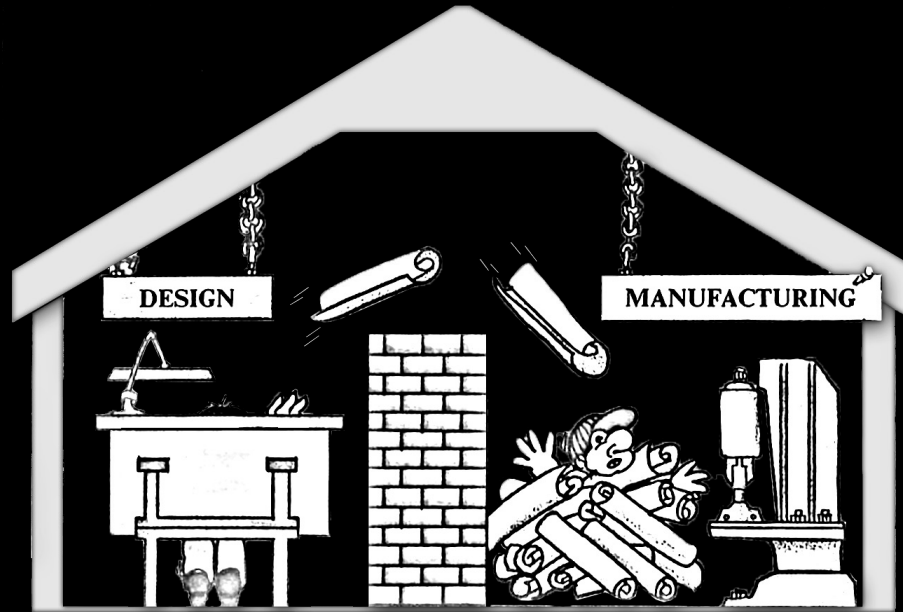

Gap between designer and manufacturer

#### References

Boothroyd, G., P. Dewhurst and W. Knight (1994). Product design for manufacture and assembly. New York, Dekker.



## INITIAL DESIGN

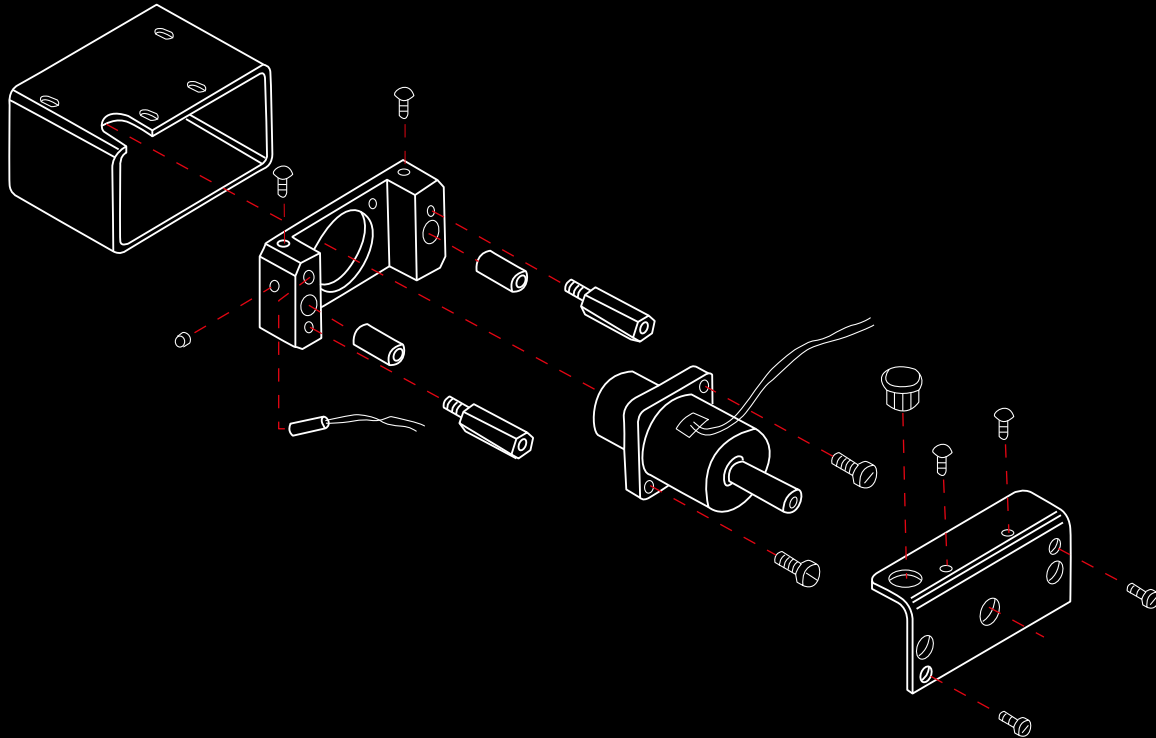

## AFTER DESIGN FOR DIS-/ASSEMBLY

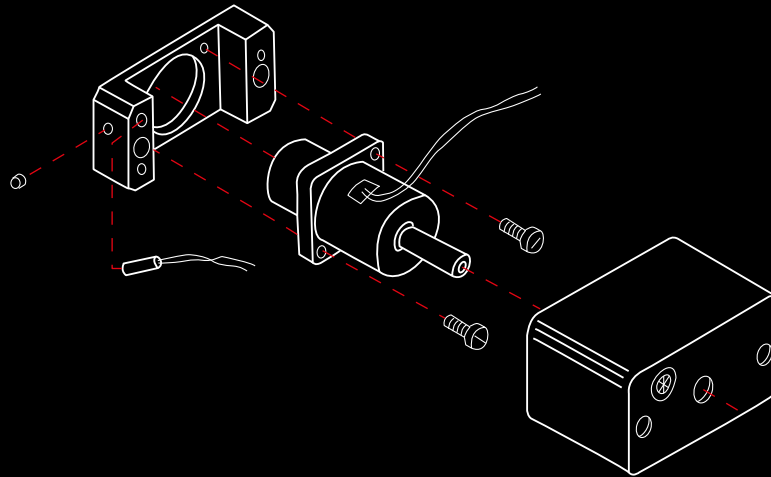

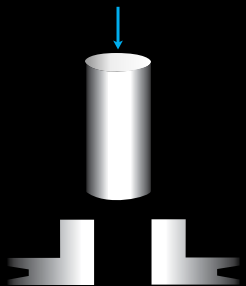

Press fitting

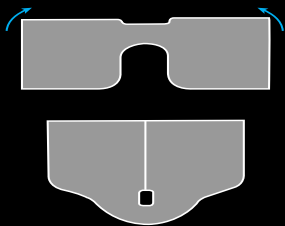

Living hinge

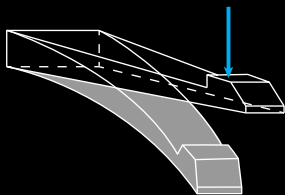

Snap fit

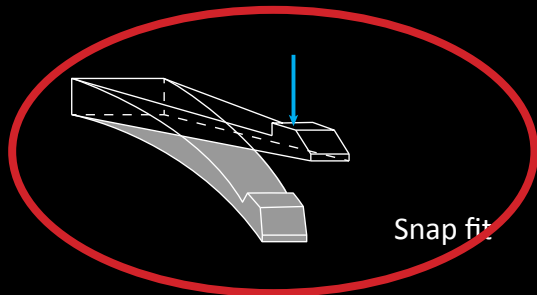

Irreversible snap-fit

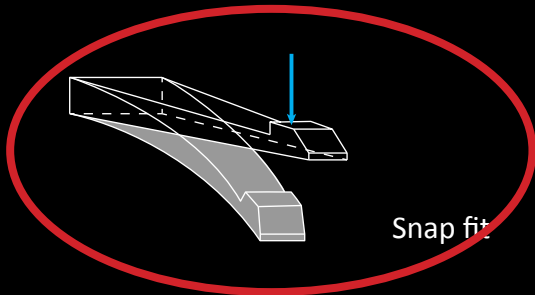

Reversible snap-fit

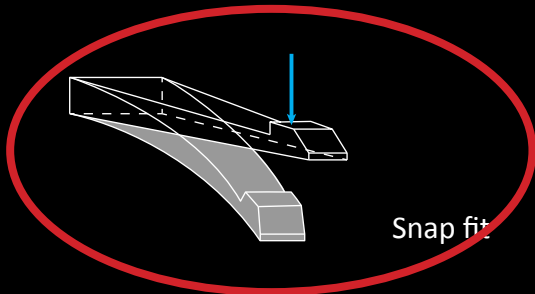

Reversible snap-fit

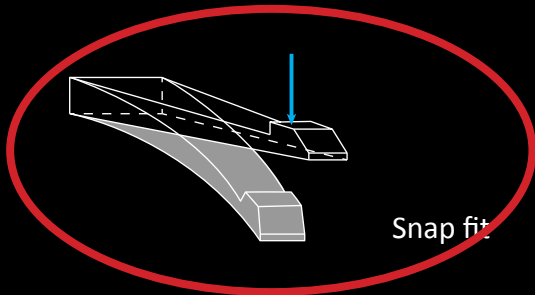
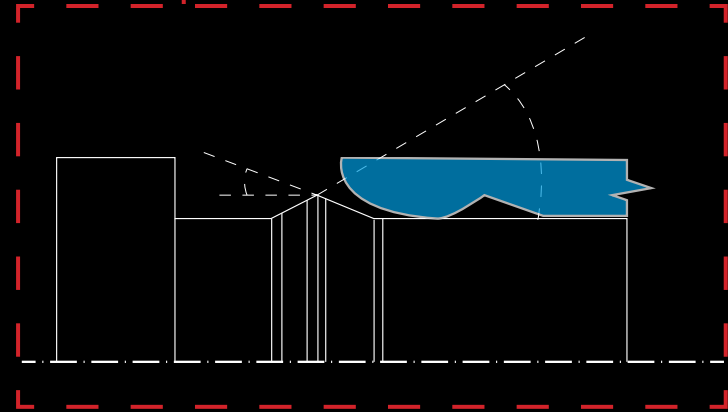

Reversible snap-fit

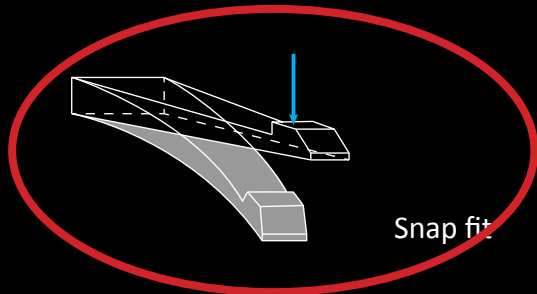

Snap fit

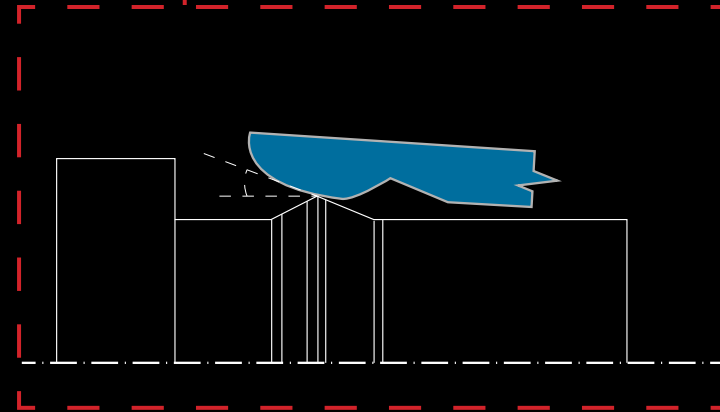

Reversible snap-fit

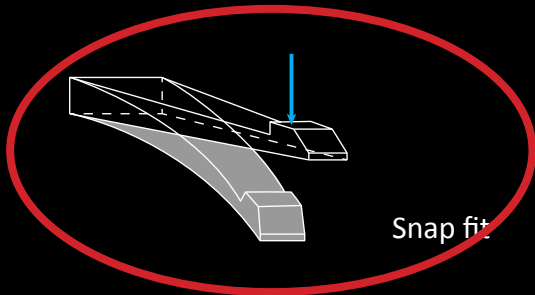
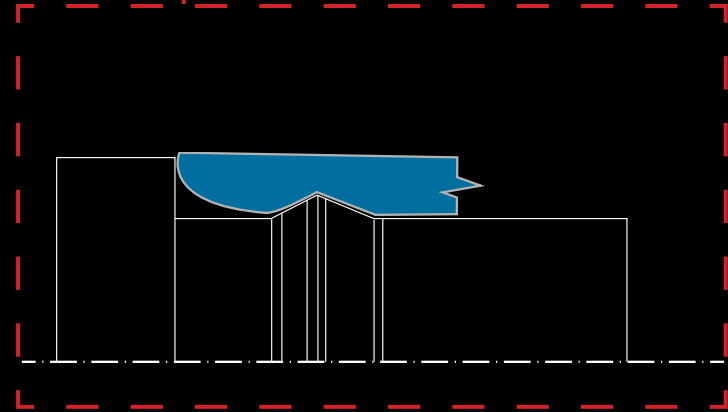

Snap fit

10 steps to disassemble

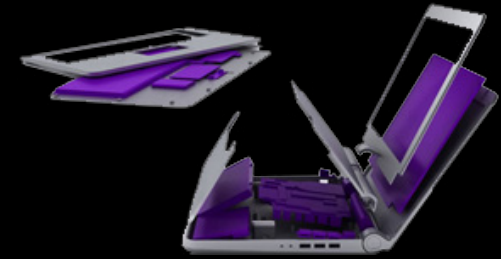

### Phoneblocks

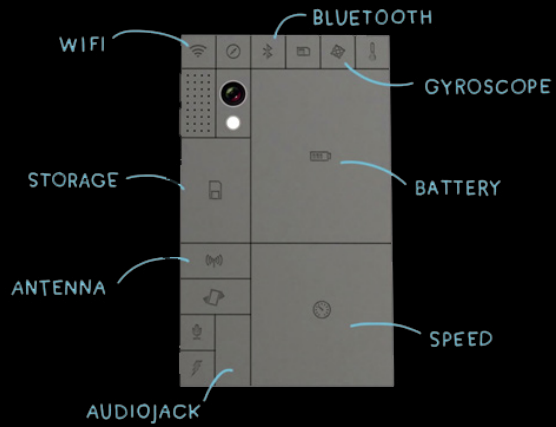



- Architectural design

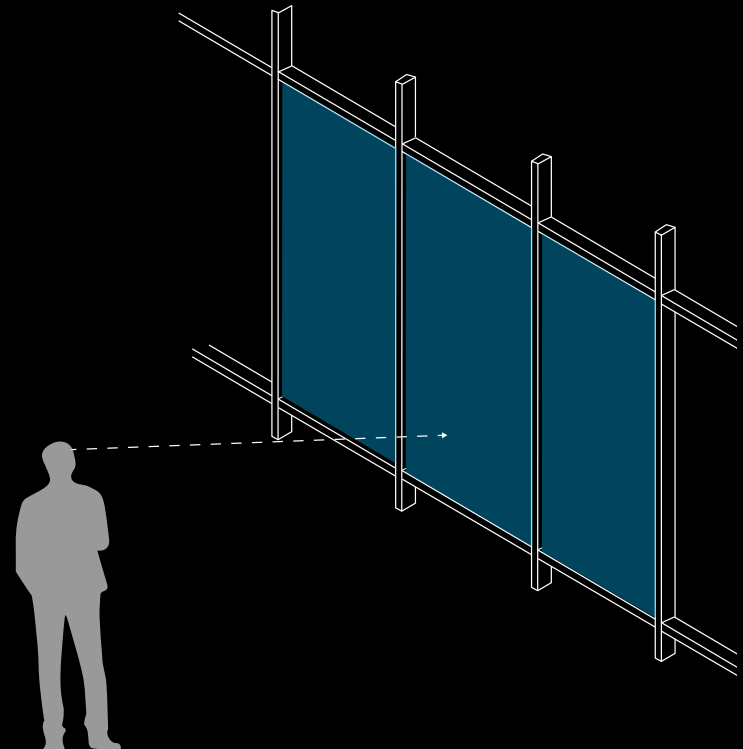

- Architectural design
- Visual comfort

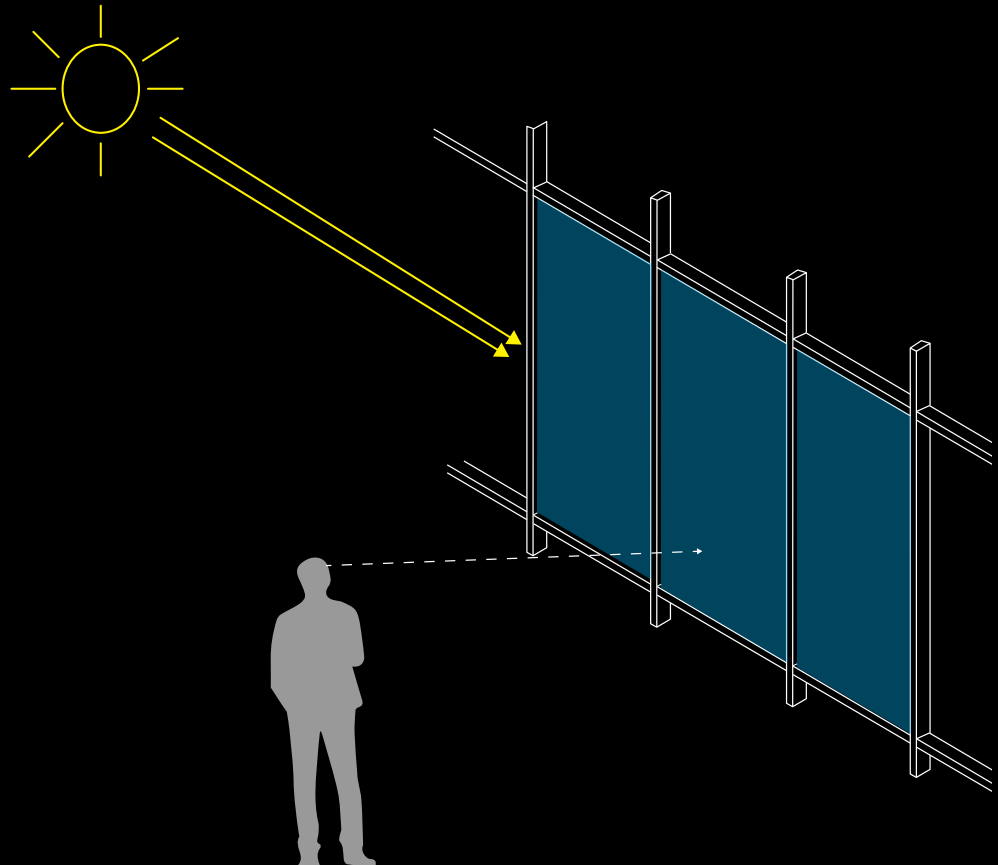

- Architectural design
- Visual comfort
- Thermal insulation

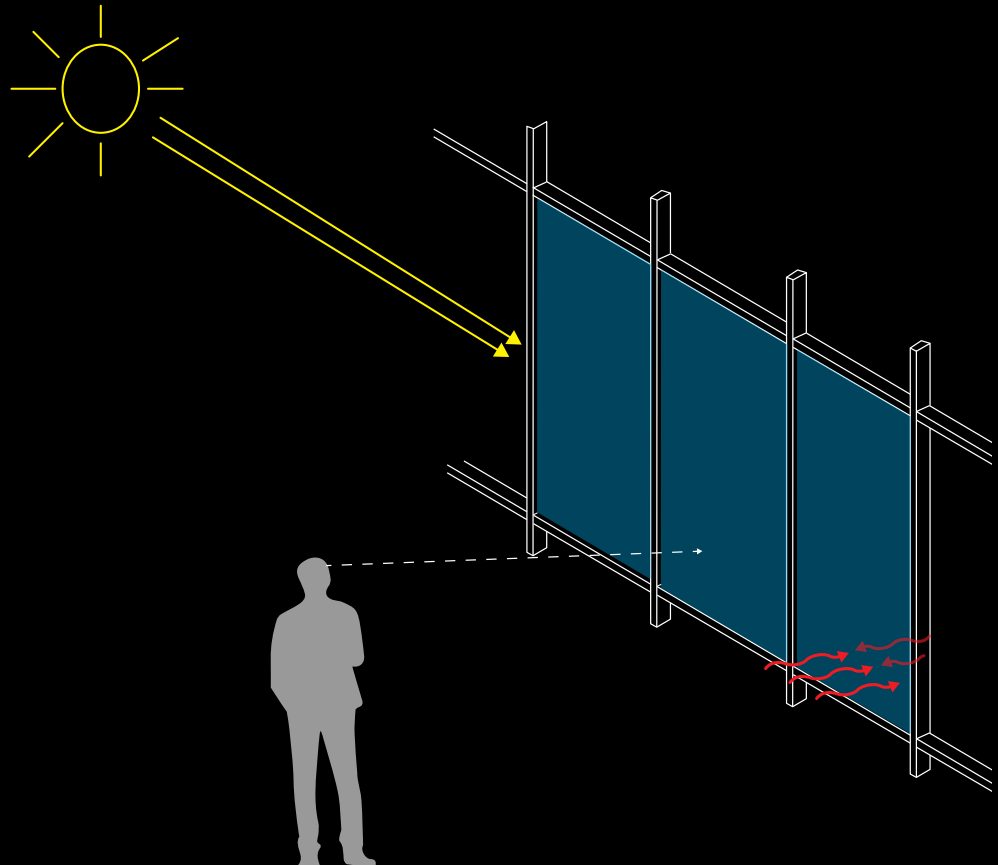

- Architectural design
- Visual comfort
- Thermal insulation
- Ventilation

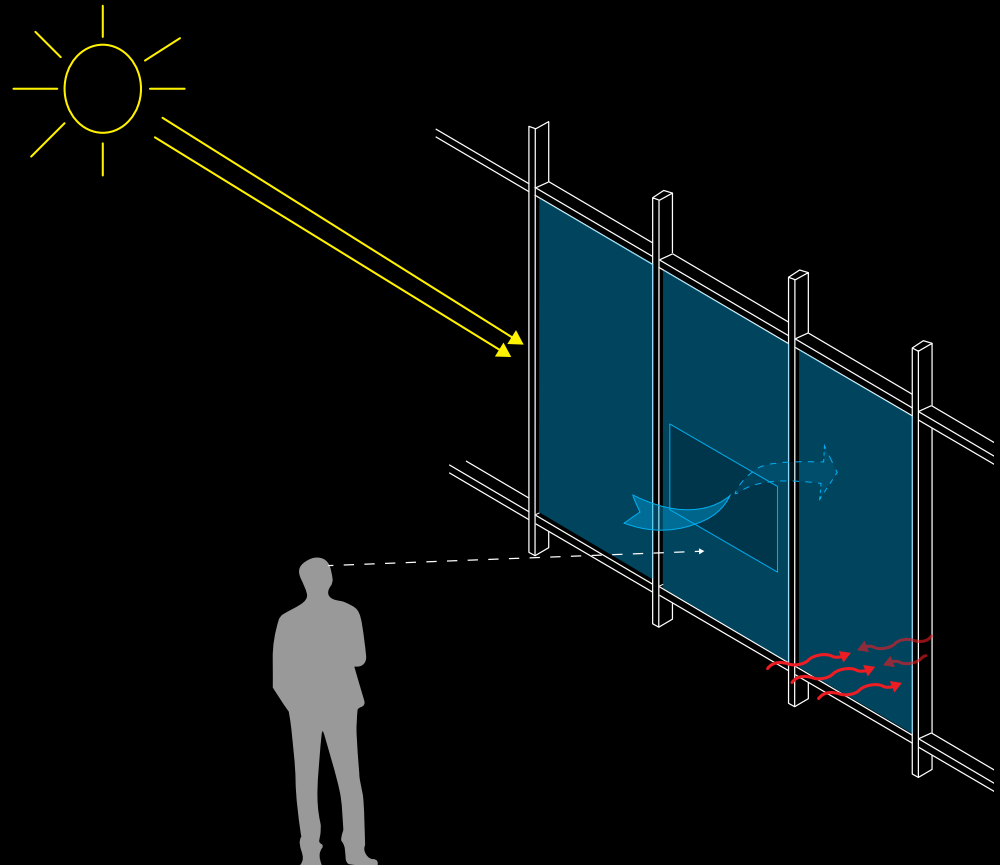

- Architectural design
- Visual comfort
- Thermal insulation
- Ventilation
- Protection from weather conditions

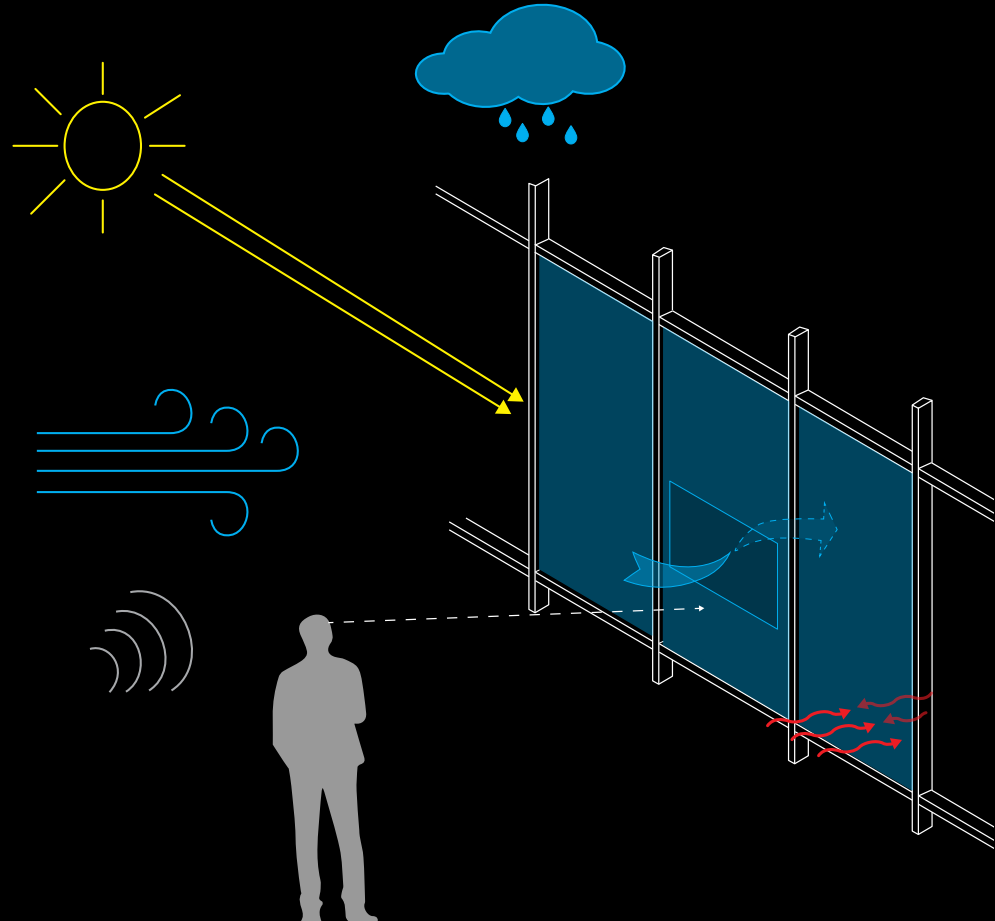

- Architectural design
- Visual comfort
- Thermal insulation
- Ventilation
- Protection from weather conditions
- Structural integrity

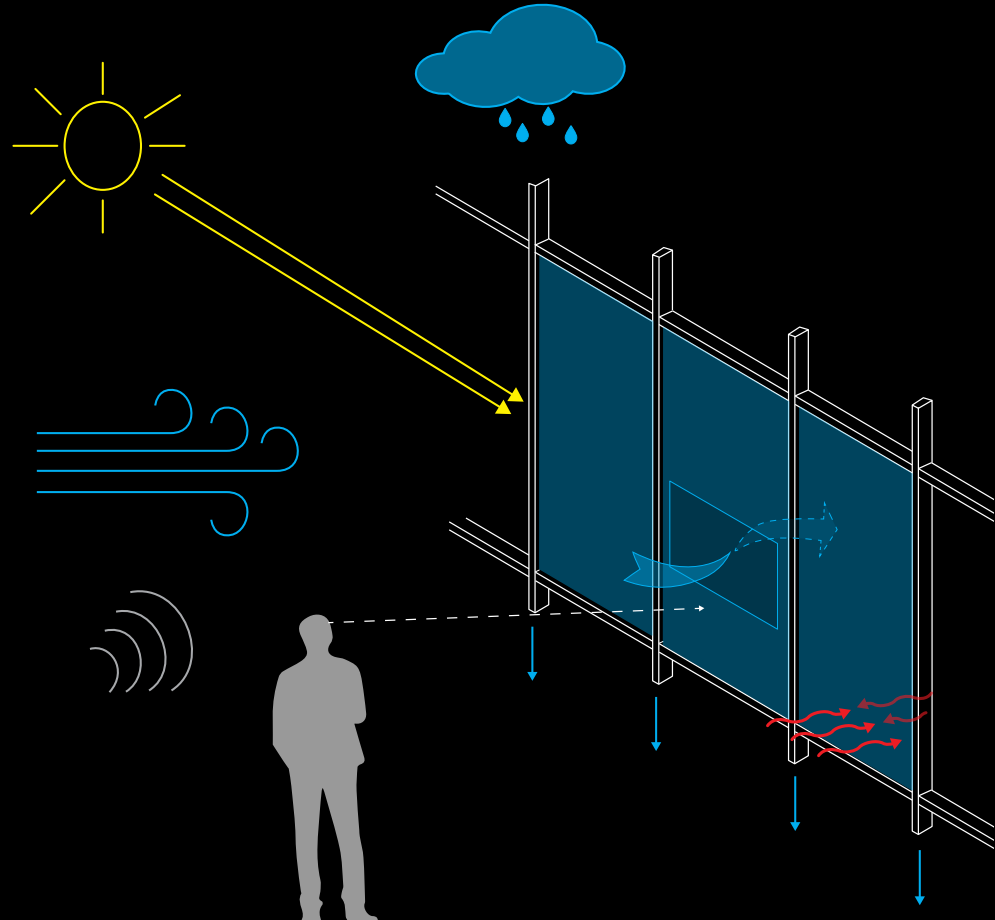

## Curtain wall systems

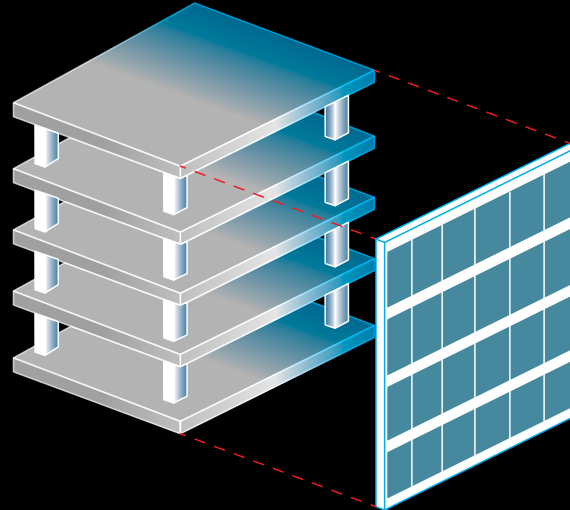

Curtain wall systems

Stick curtain wall

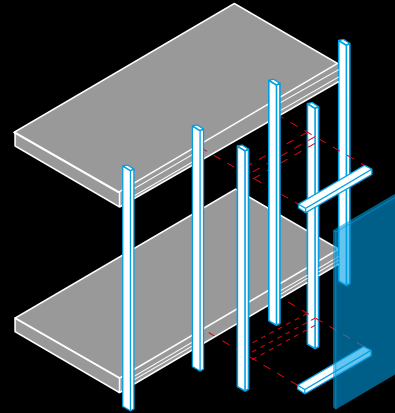

Unitised facade

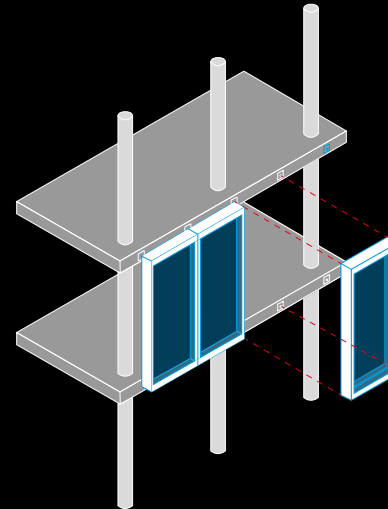

Curtain wall systems

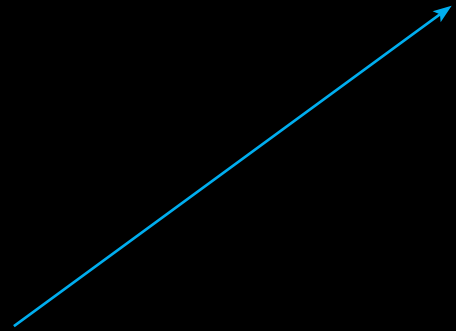

Stick curtain wall

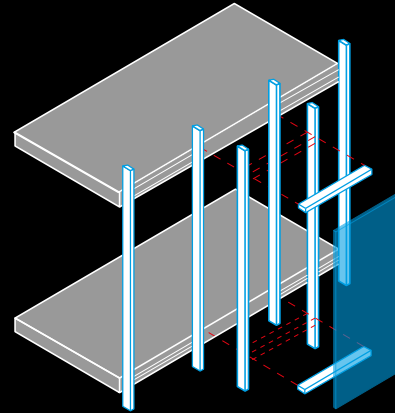

Curtain wall systems

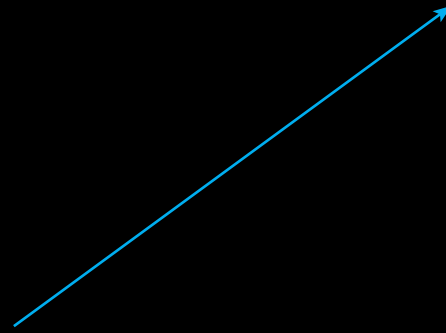

Stick curtain wall

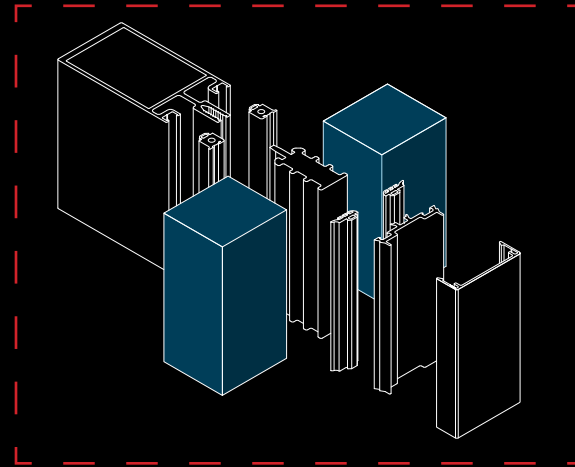
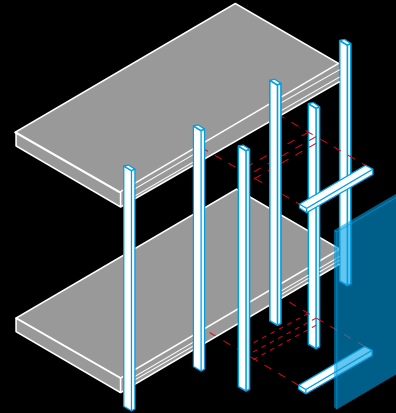

Curtain wall systems

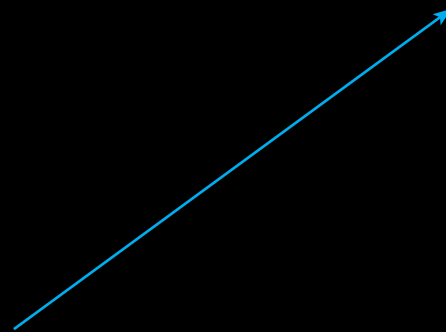

Stick curtain wall

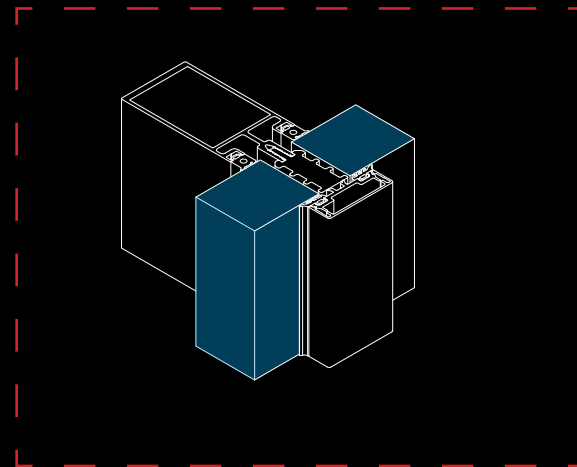
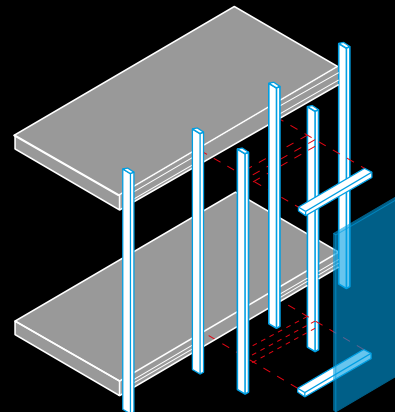

Curtain wall systems

Unitised facade

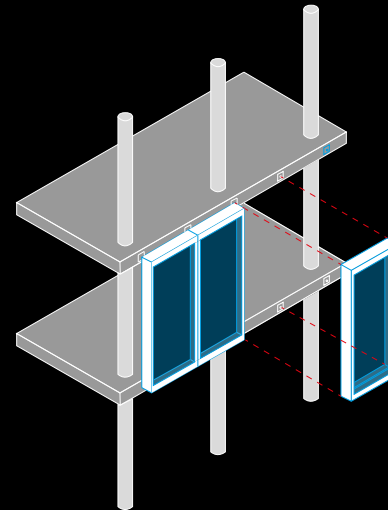

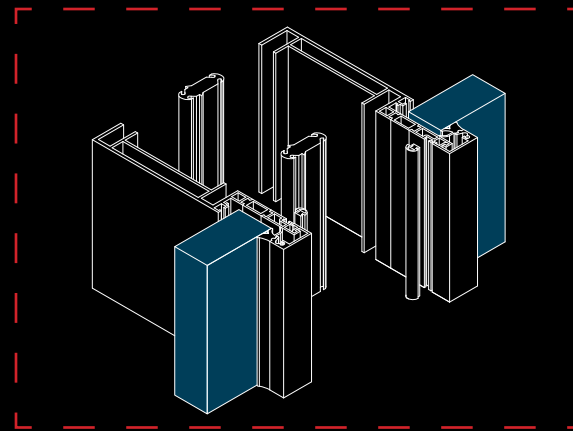

Curtain wall systems

Unitised facade

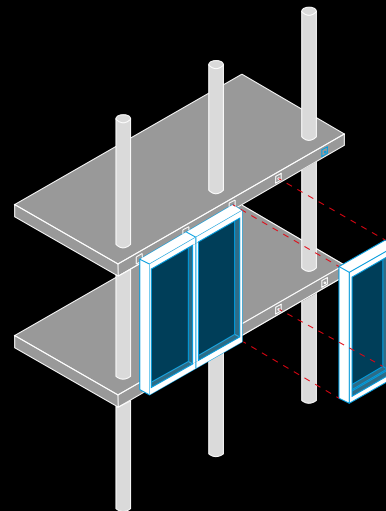

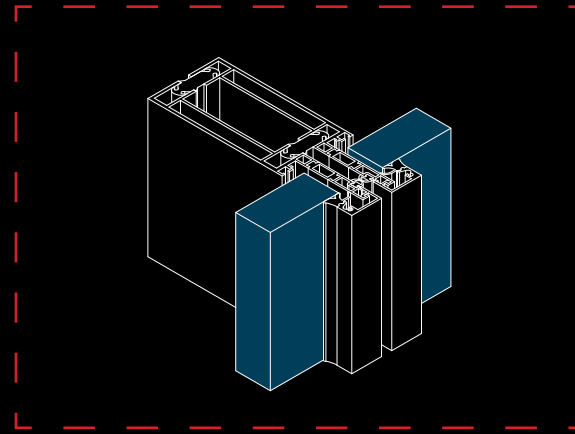

Curtain wall systems

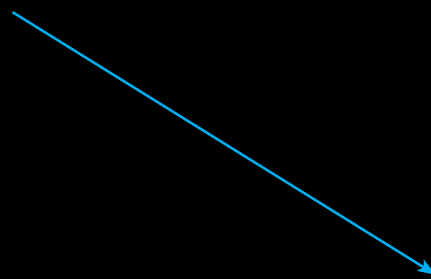

Unitised facade

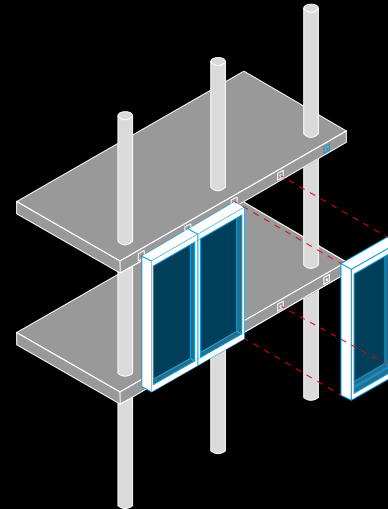

## Design for easy dis-/assembly

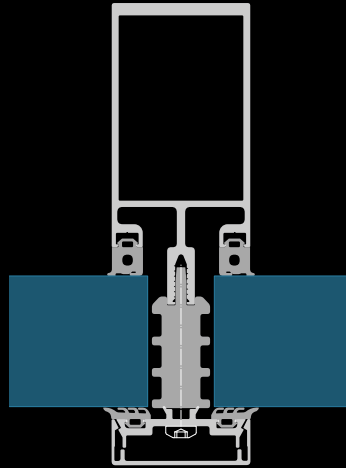

## Design for easy dis-/assembly

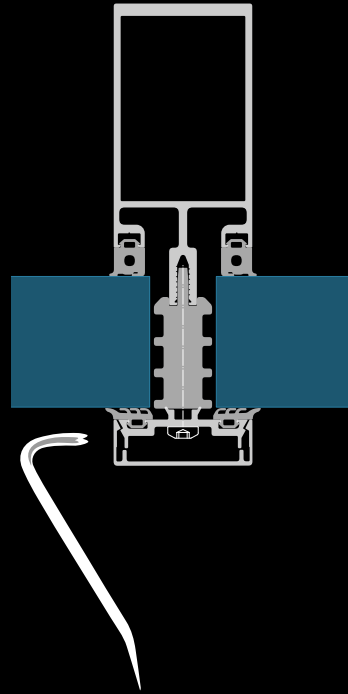

## Design for easy dis-/assembly

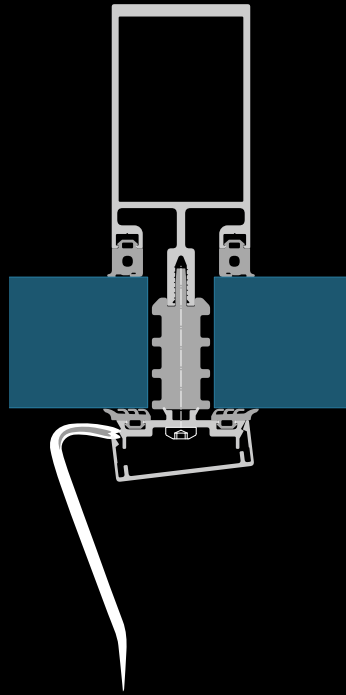

## Design for easy dis-/assembly

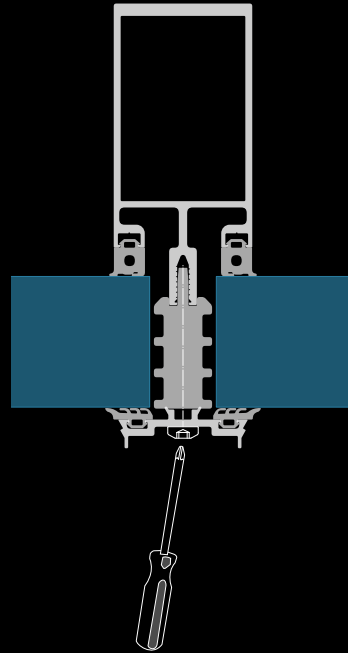

## Design for easy dis-/assembly

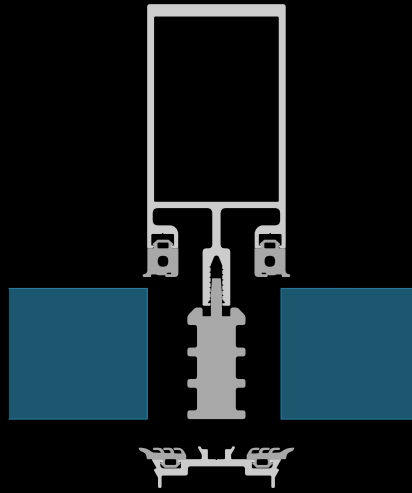

## Life span of materials

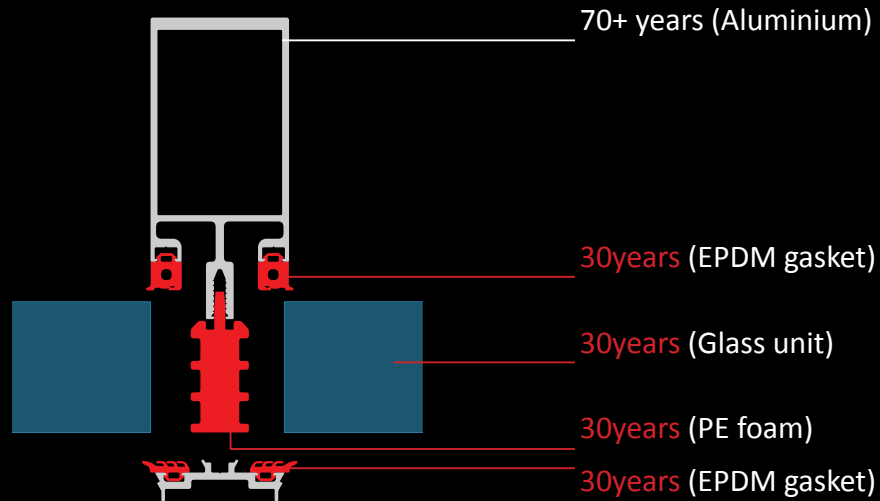

## Life span of materials

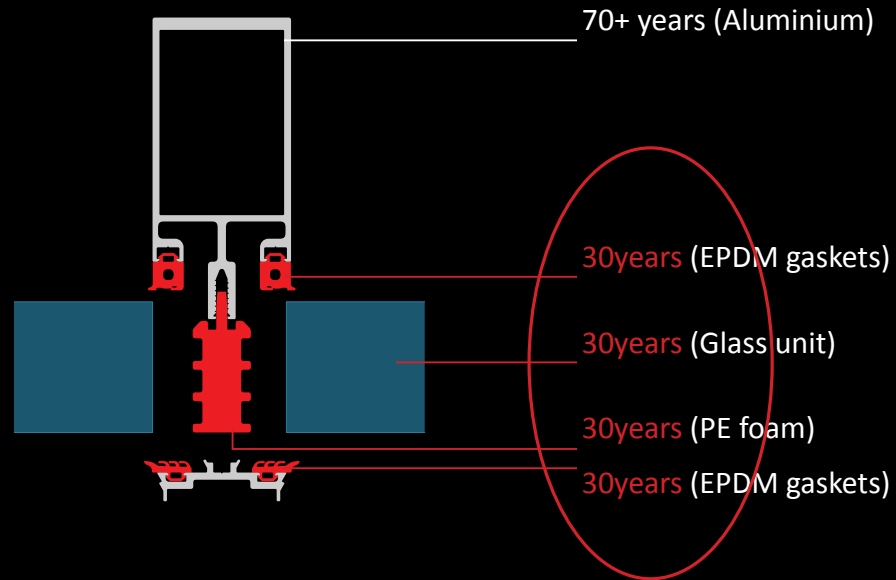

## Façade's service life

30 years

60 years

120 years



## Façade's service life

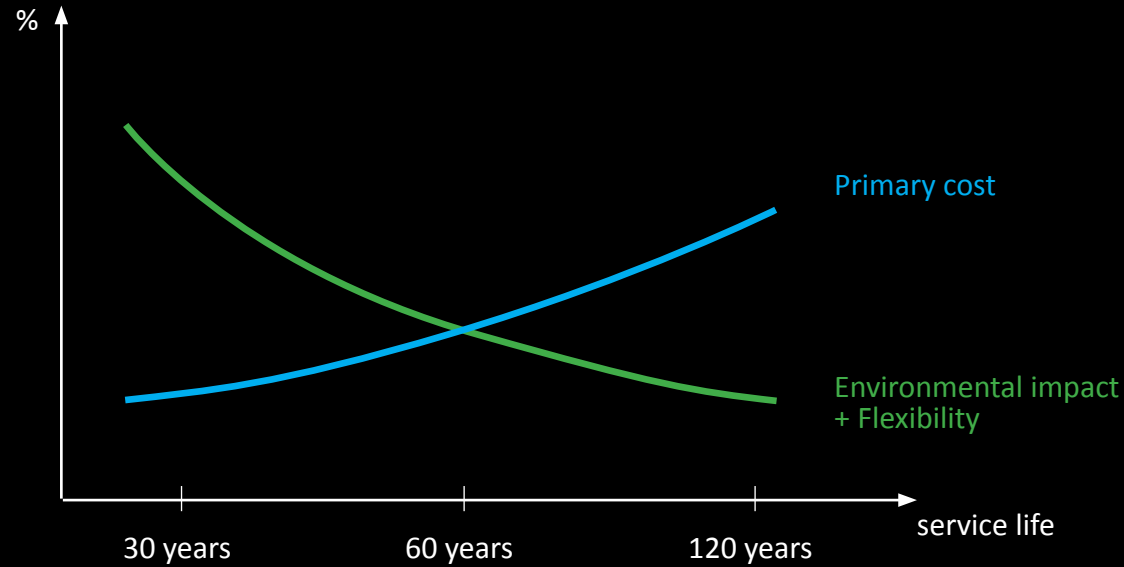

## Façade's service life

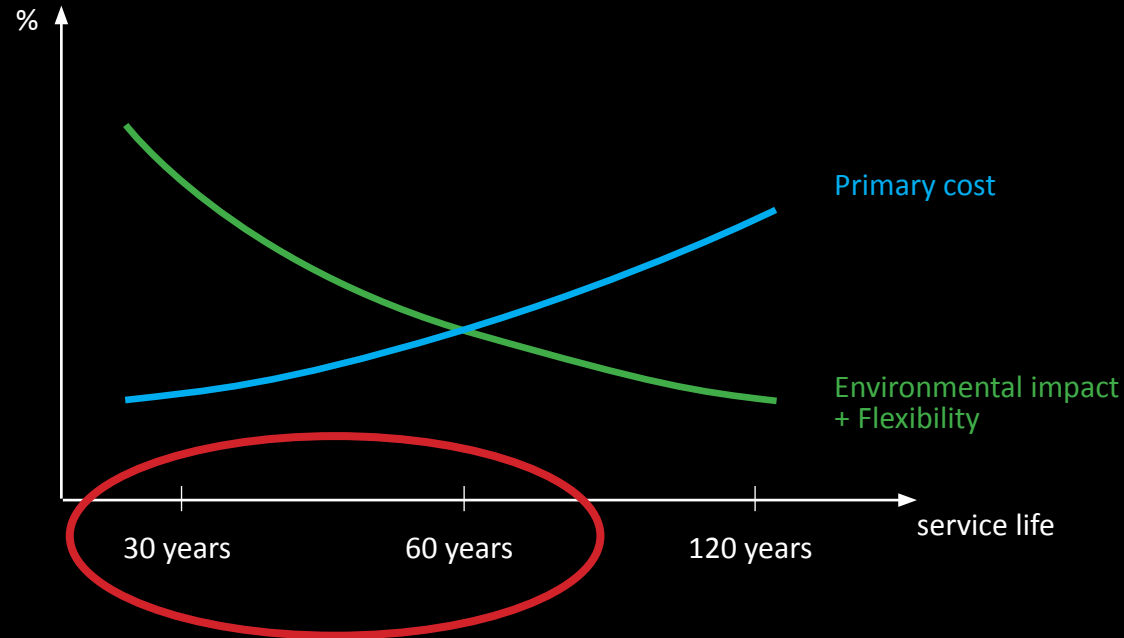

## Mechanical, Maritime and Materials Engineering Faculty (3mE)

- Use educational => regular changes
- Design 4 modular wings connected

~100m<sup>2</sup>



## Typical Dutch construction

(brick facade - insulation - concrete wall)

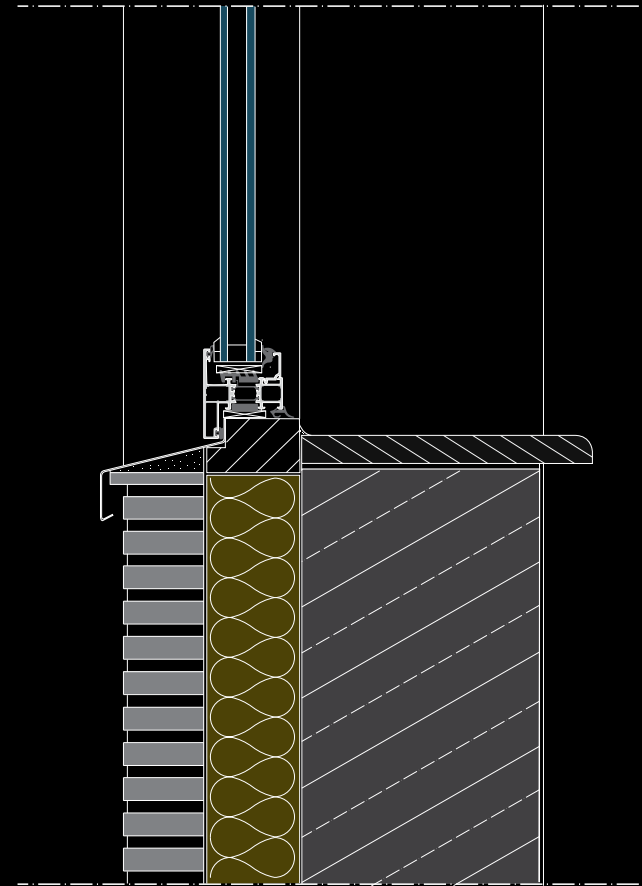
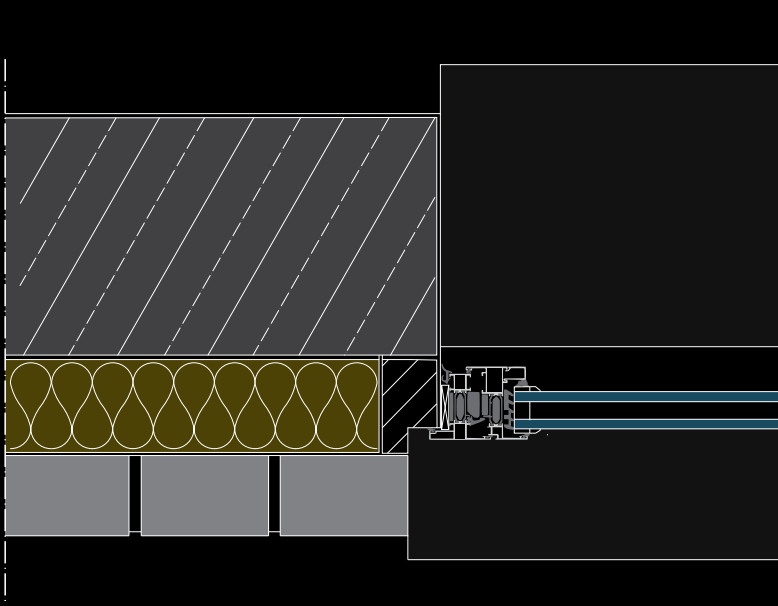

## Scenarios of service life

15 years service life

## Scenarios of service life

15 years service life

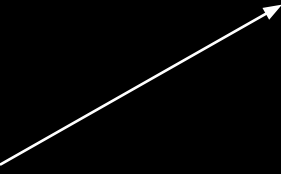

replace only the facade  
building serv.life = 60 years

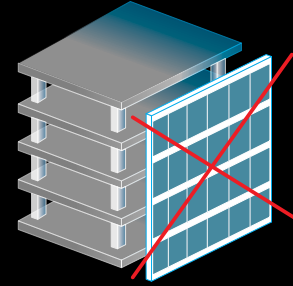

## Scenarios of service life

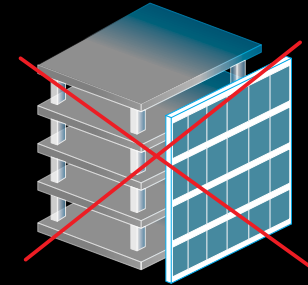
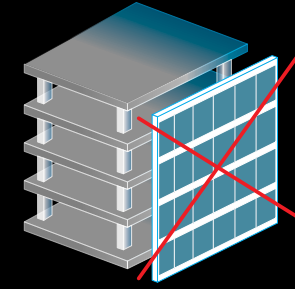
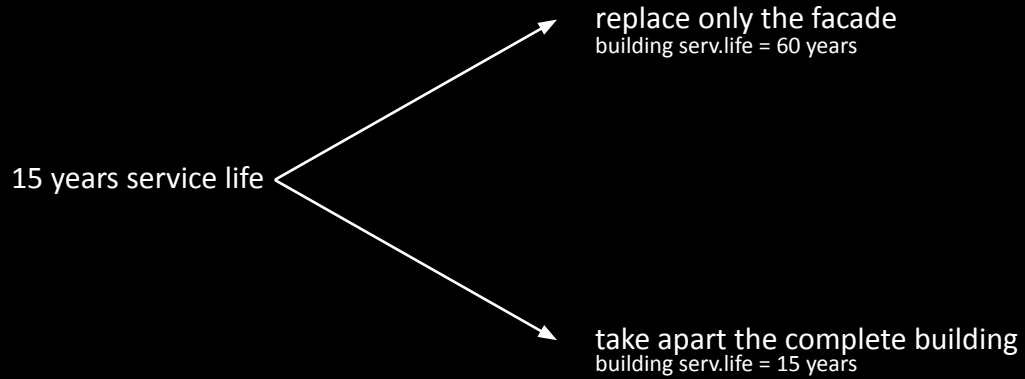

## Scenarios of service life

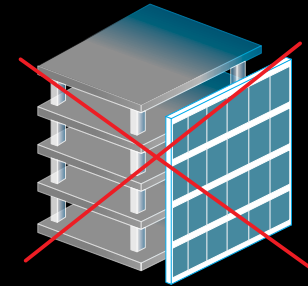
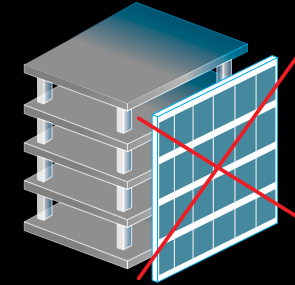
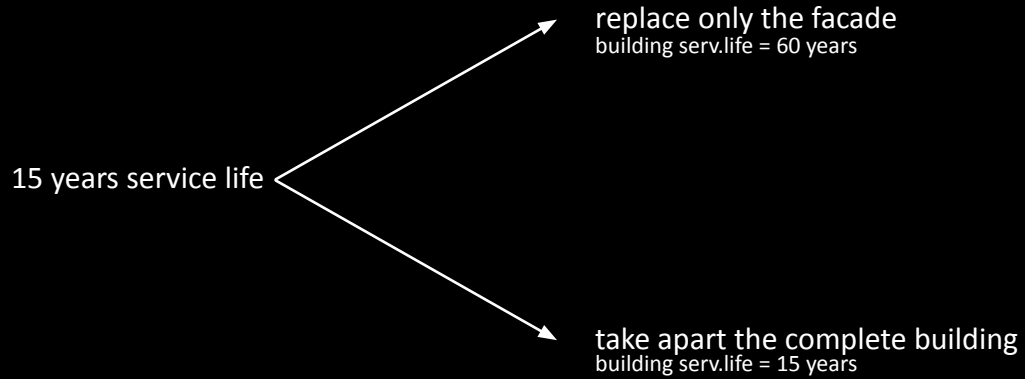

60 years service life

## Scenarios of service life

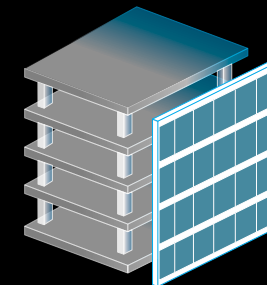
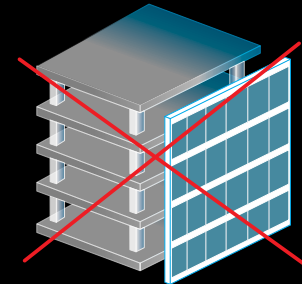
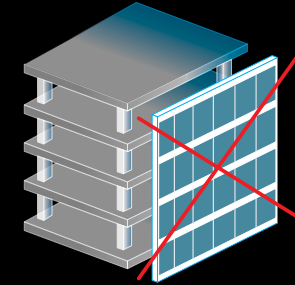
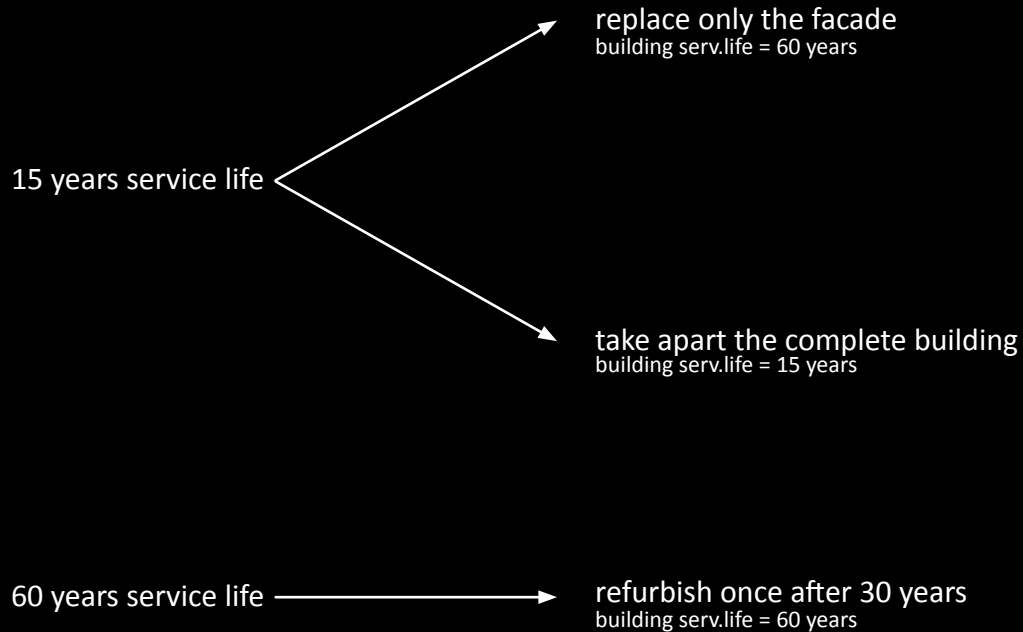

- Span of 60 years in total
- No material losses during disassembly and transportation to recycling shredder
- Highest percentages of material recovery through recycling
- Values acquired: average data (CES Edupack 2014)
- Façade's performance: efficient
- Only triple glazing is evaluated for the long-term scenario
- Feasibility, experience, current equipment considered for the redesign

## Detailing

15 years service life

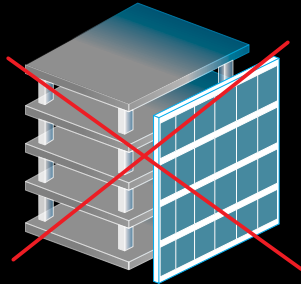
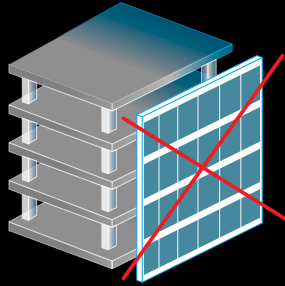

60 years service life

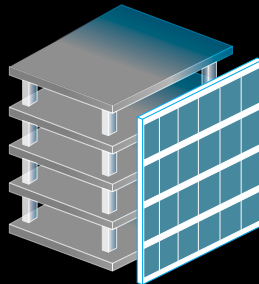

## Detailing

15 years service life

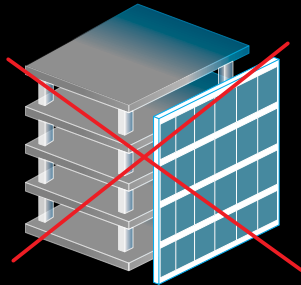
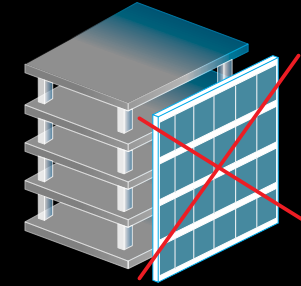

60 years service life

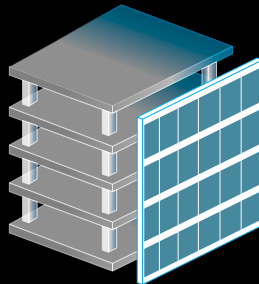

## Stick curtain wall

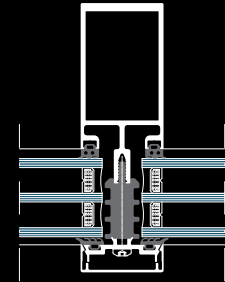

## Detailing

15 years service life

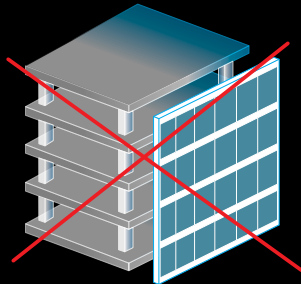
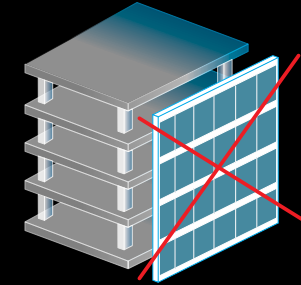

60 years service life

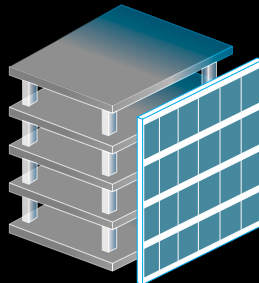

## Stick curtain wall

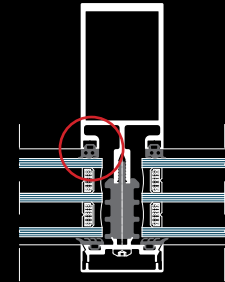
reduced tolerance for  
adjustments in glazing

## Detailing

15 years service life

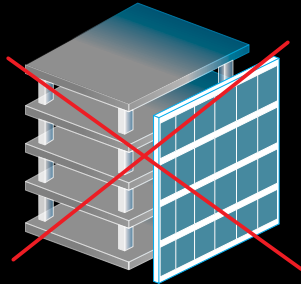
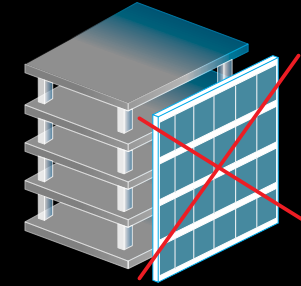

60 years service life

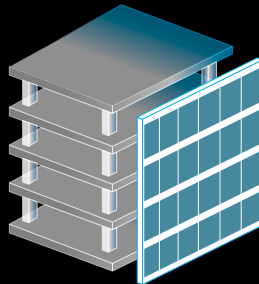

## Stick curtain wall

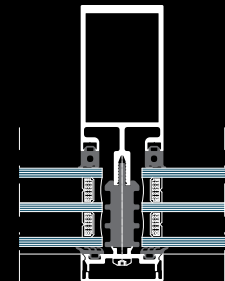
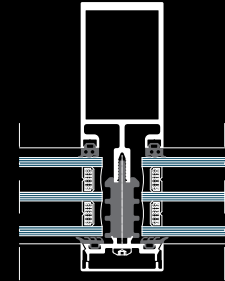

## Detailing

15 years service life

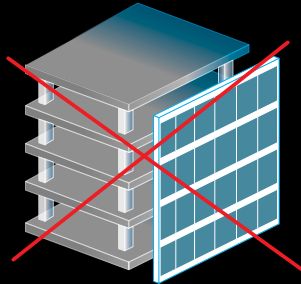
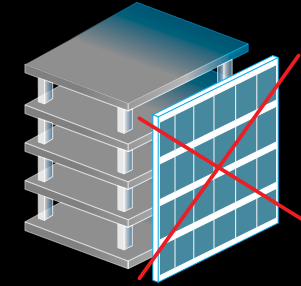

60 years service life

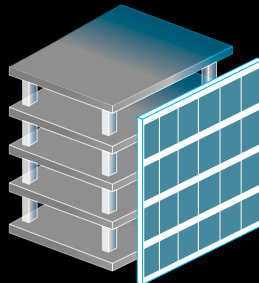

## Stick curtain wall

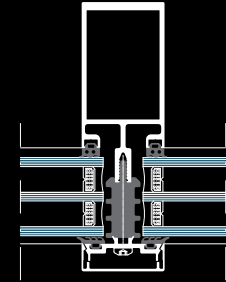
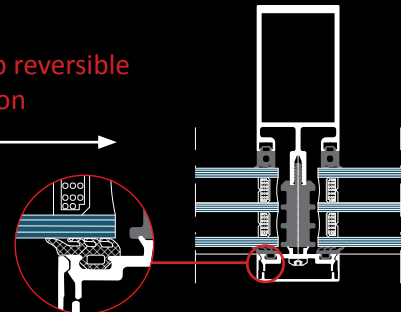
cover cap reversible  
connection

## Detailing

15 years service life

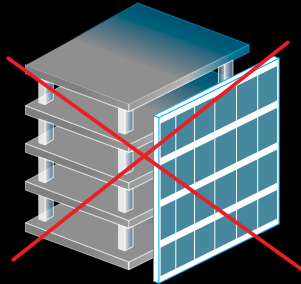
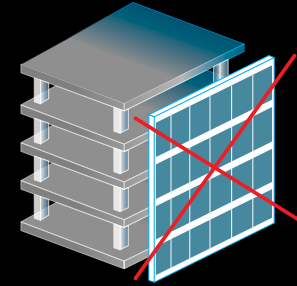

60 years service life

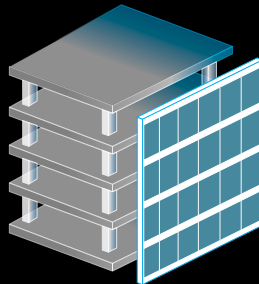

## Stick curtain wall

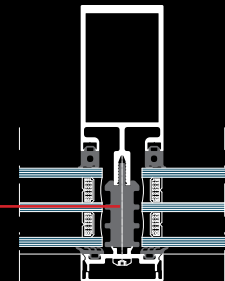
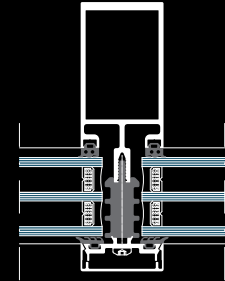

replace with Nylon polyamide

## Detailing

15 years service life



## Stick curtain wall

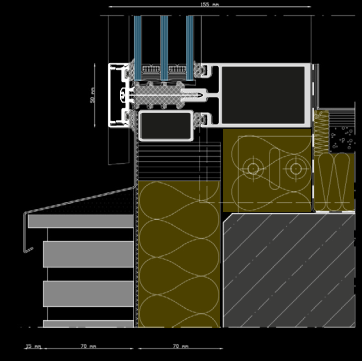

60 years service life

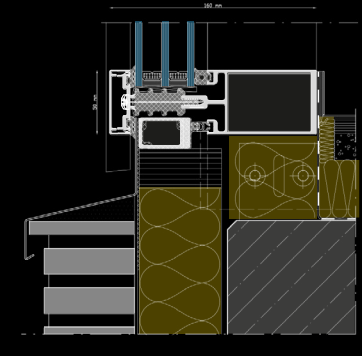
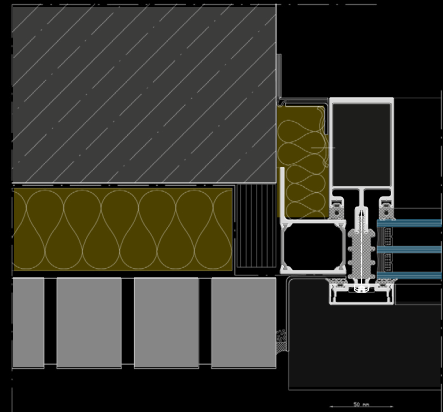

## Detailing

15 years service life

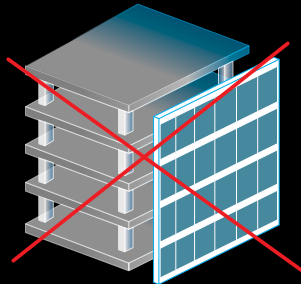
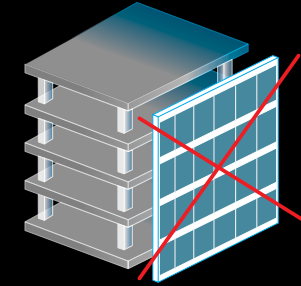

60 years service life

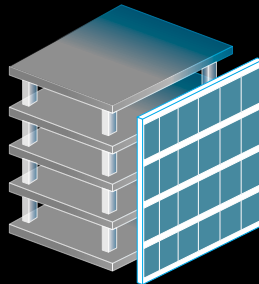

## Unitised facade

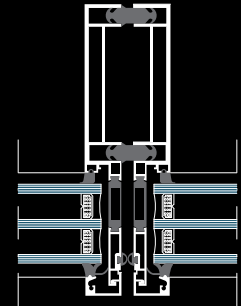
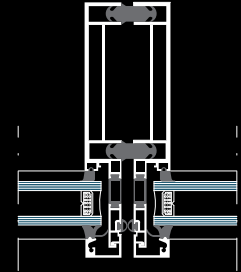

## Energy evaluation

$$\begin{aligned}
 & \text{Primary Embodied Energy} \\
 & + \\
 & \text{Refurbishment/Replacement Embodied Energy} \\
 & + \\
 & \text{End-of-life Energy} \\
 & = \\
 & \text{Total Embodied Energy of evaluated energy} \\
 & (\text{Refurbishment E.E.} = x \% \text{ recycling E.E.} + y \% \text{ primary E.E.})
 \end{aligned}$$

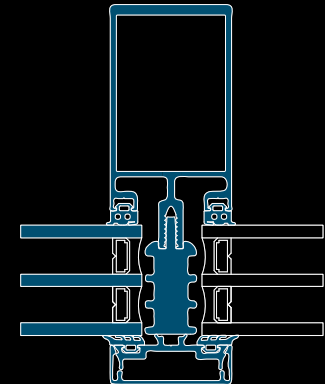
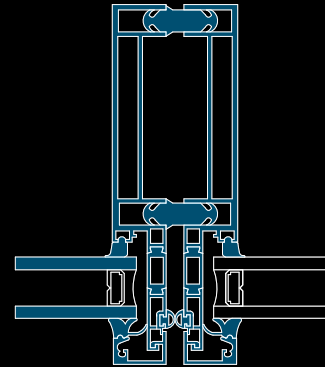
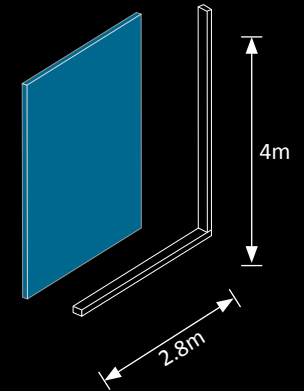
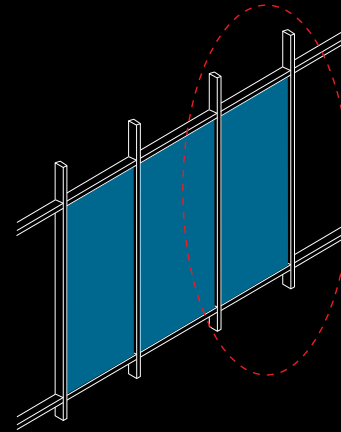

■ Evaluated elements for primary energy

\*Respectively for the CO<sub>2</sub> emissions.

## Energy evaluation

Embodied energy  
&  
CO<sub>2</sub> emissions

## Energy evaluation

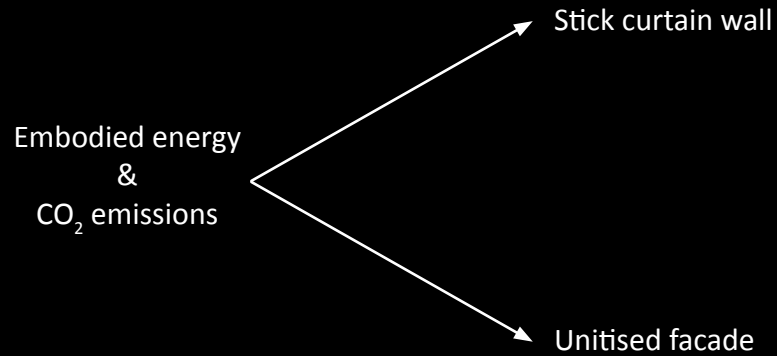

## Energy evaluation

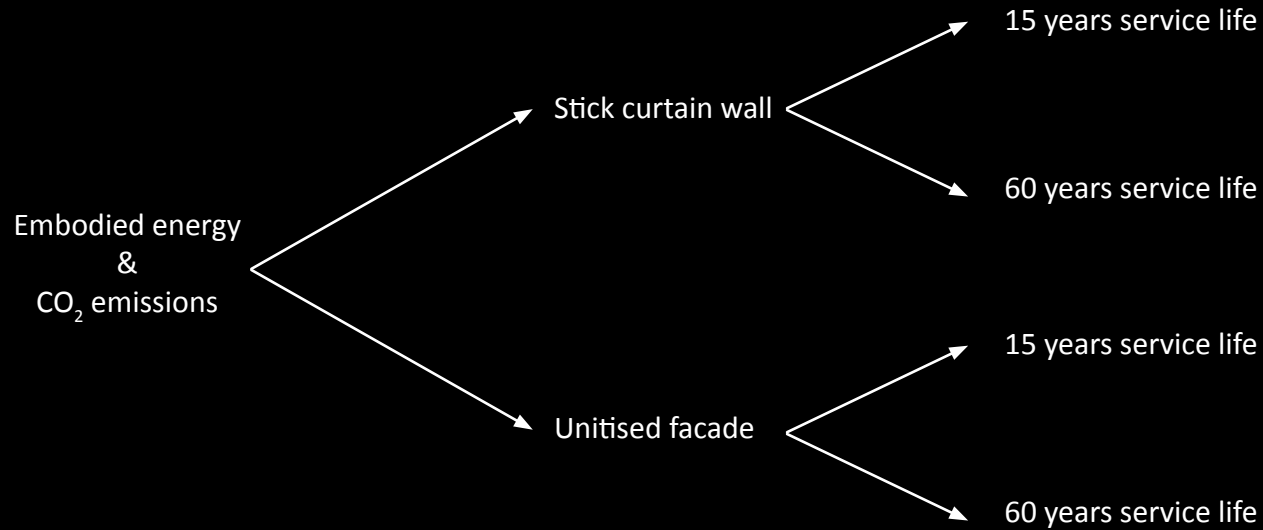

## Energy evaluation

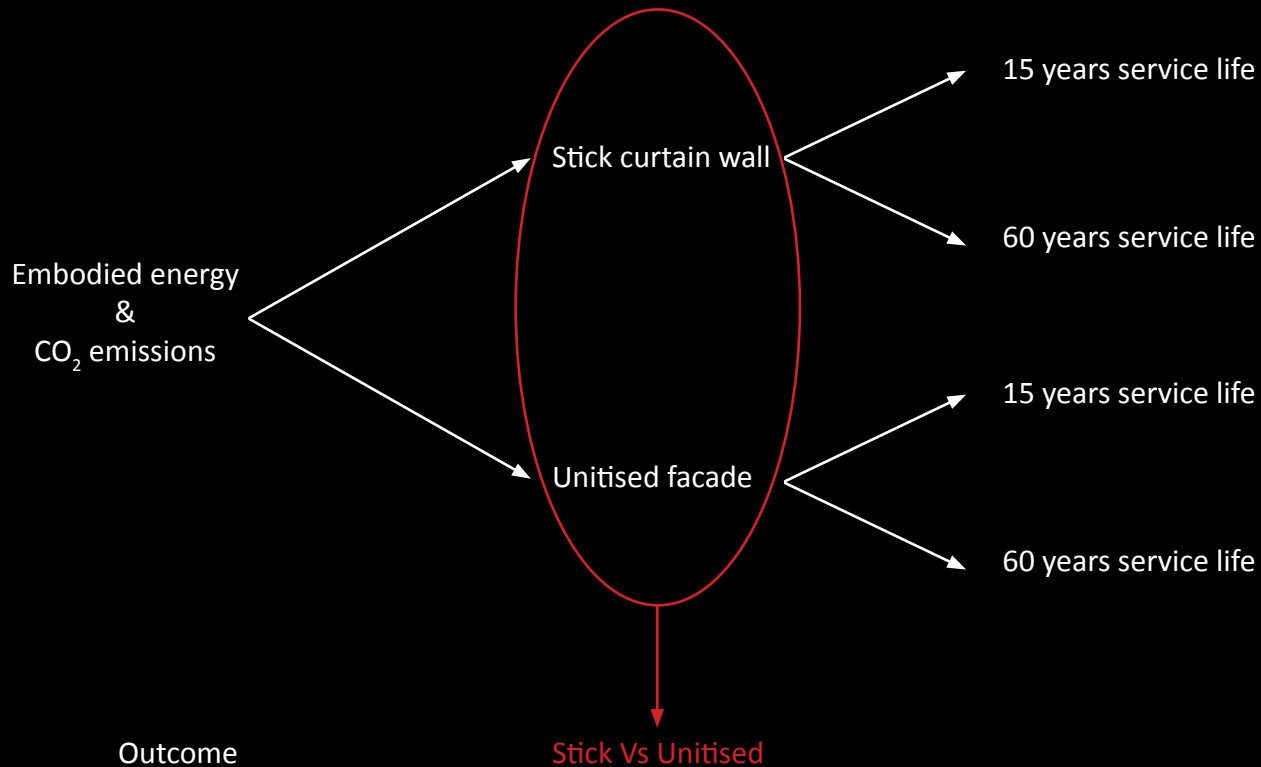

## Energy evaluation

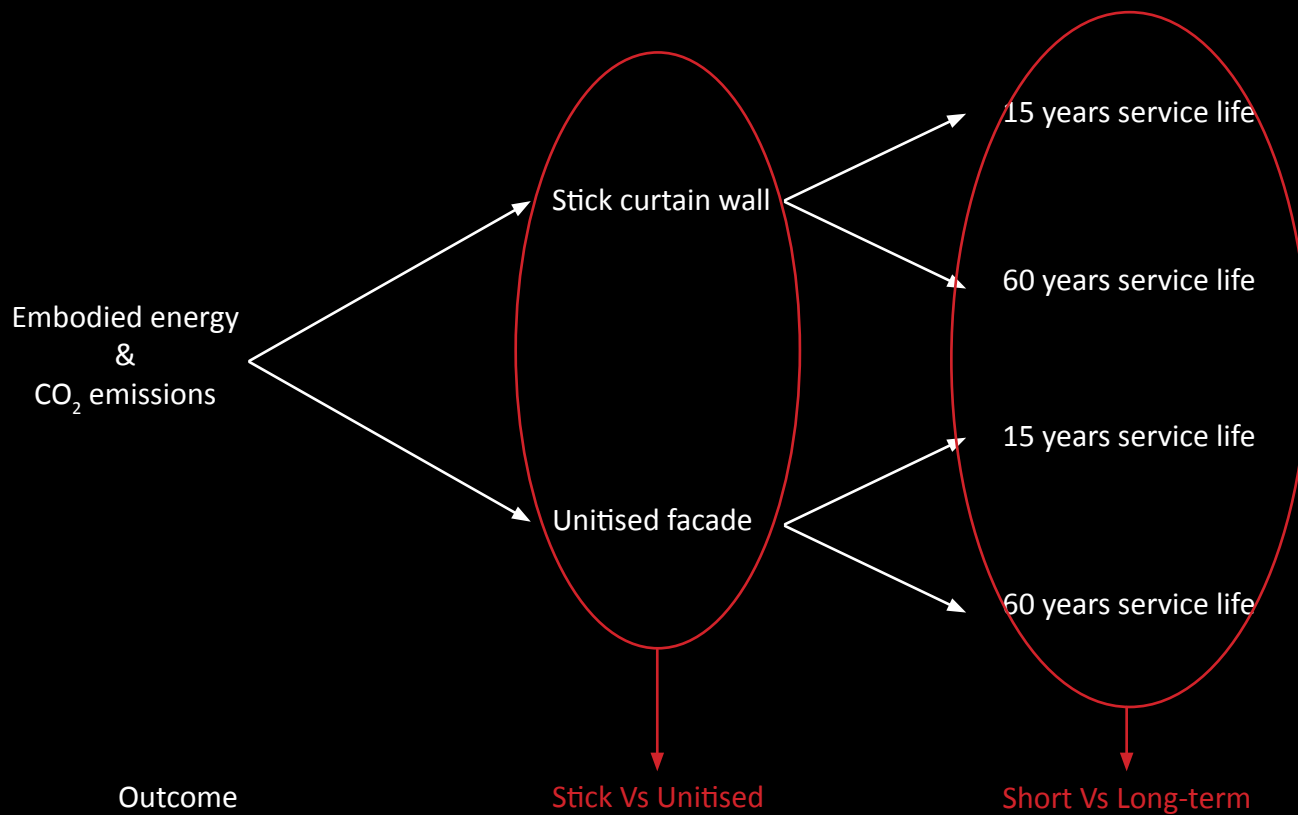

## Comparison of Results

Glazing: double

Refurbishments: 2

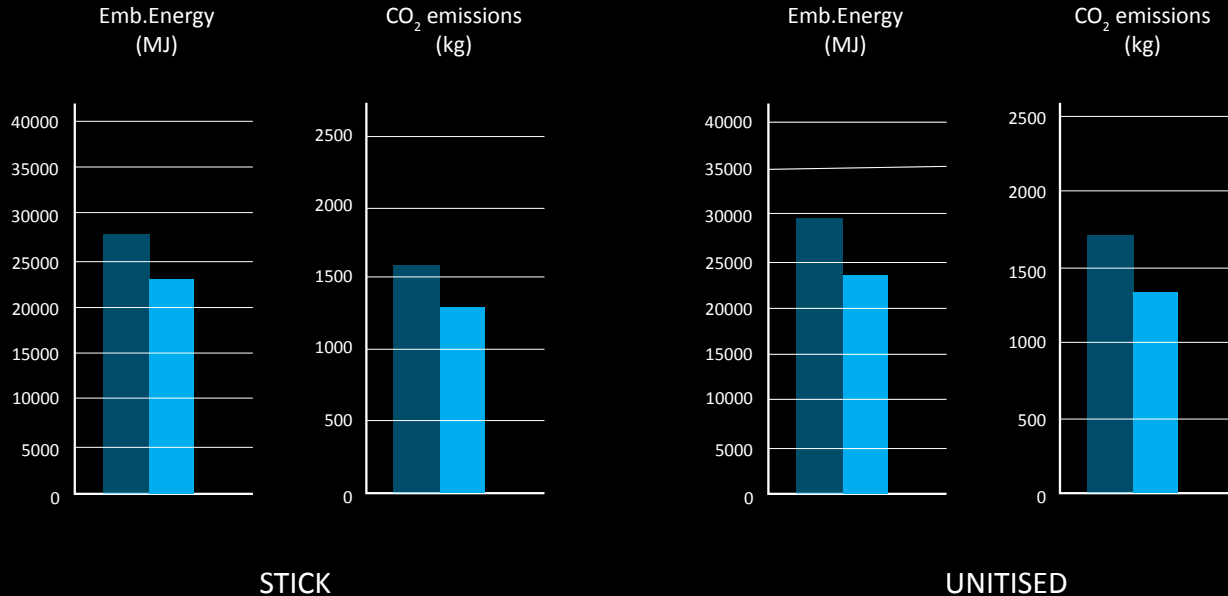

## Comparison of Results

Glazing: double

Refurbishments: 2

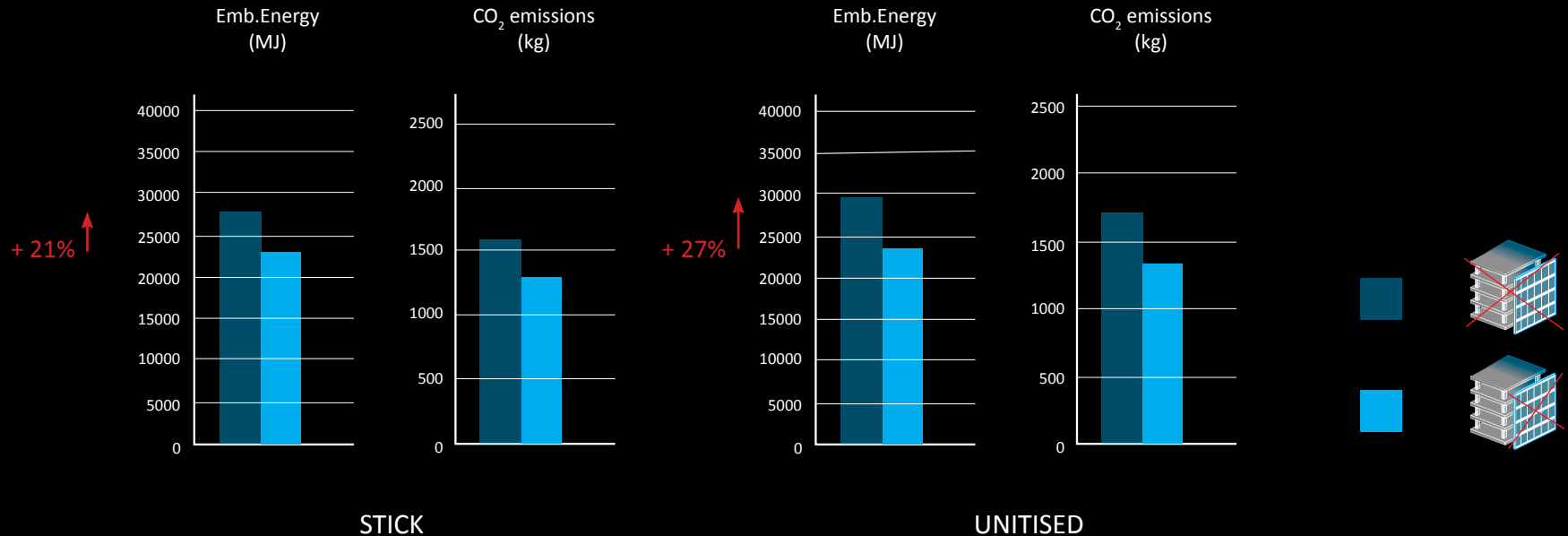

## Comparison of Results

Glazing: triple

Refurbishments: 2

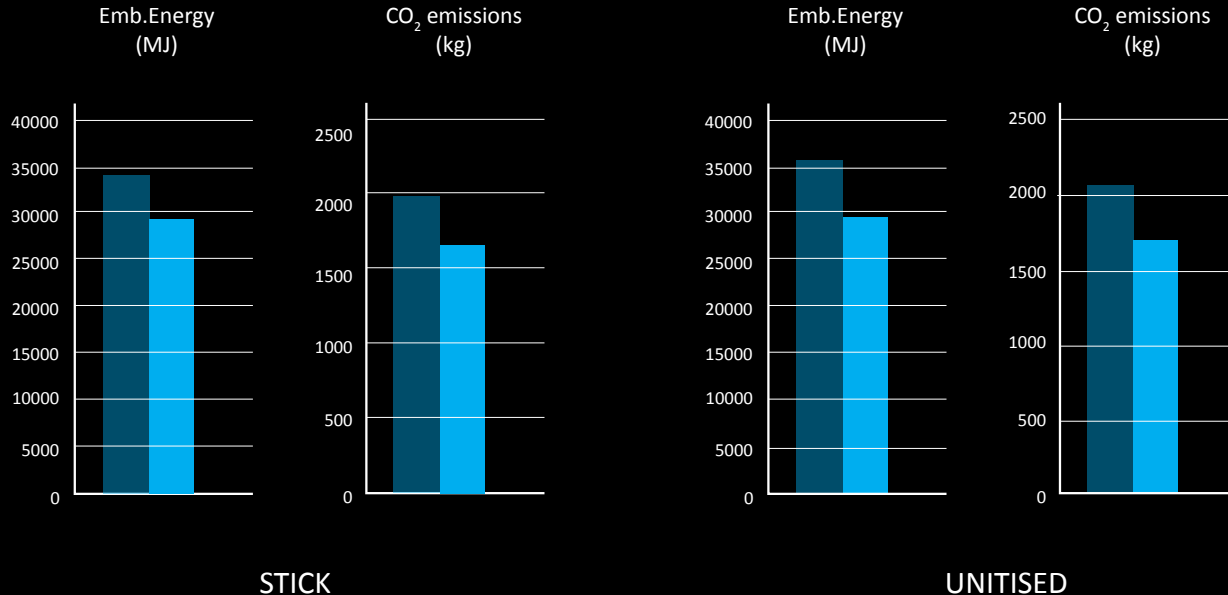

## Comparison of Results

Glazing: triple

Refurbishments: 2

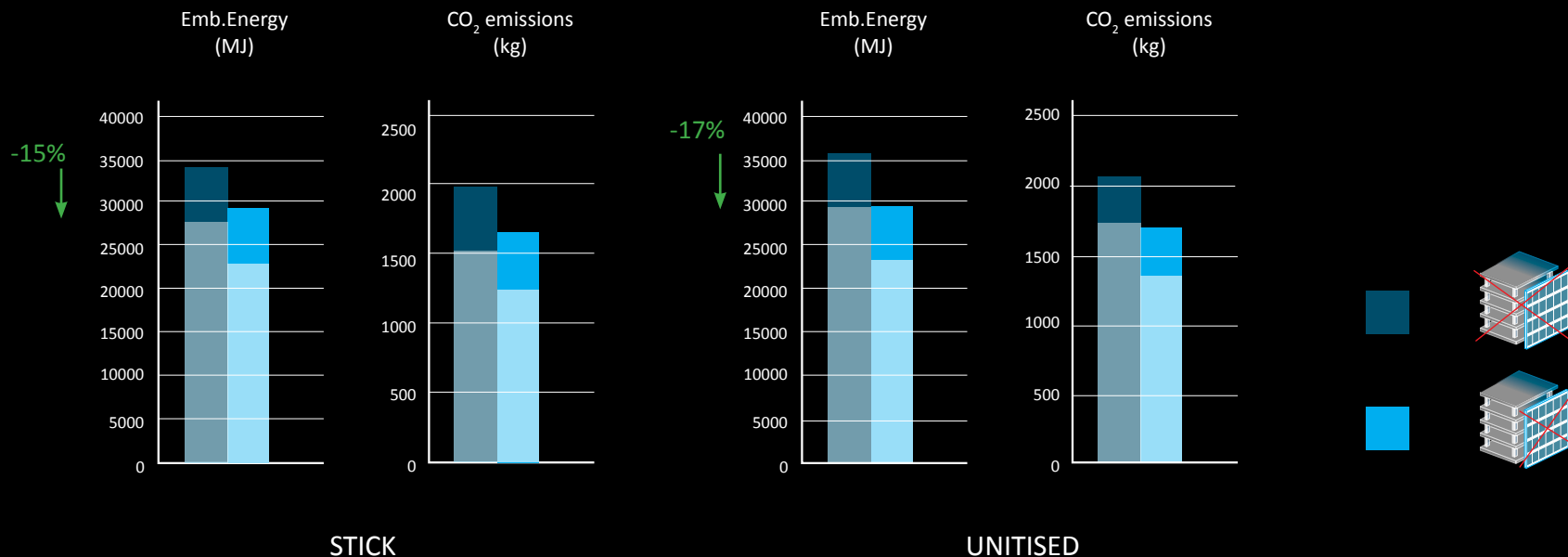

## Comparison of Results

Glazing: triple

Refurbishments: 2

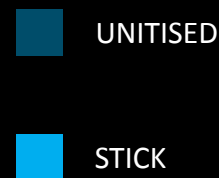
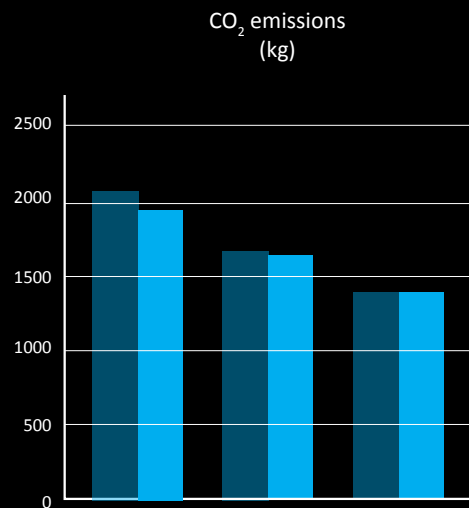
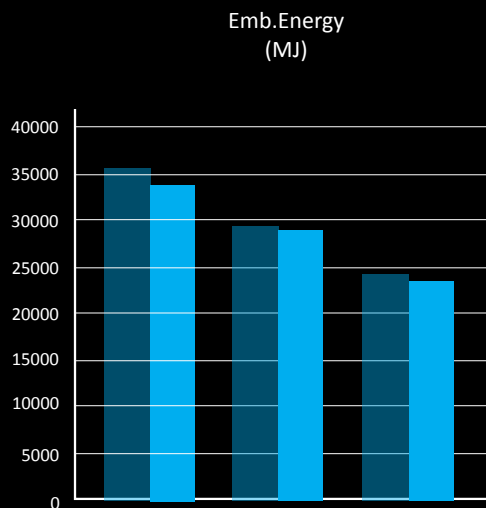

## Comparison of Results

Glazing: triple

Refurbishments: 2

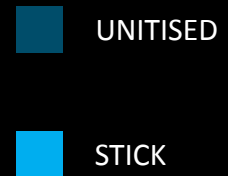
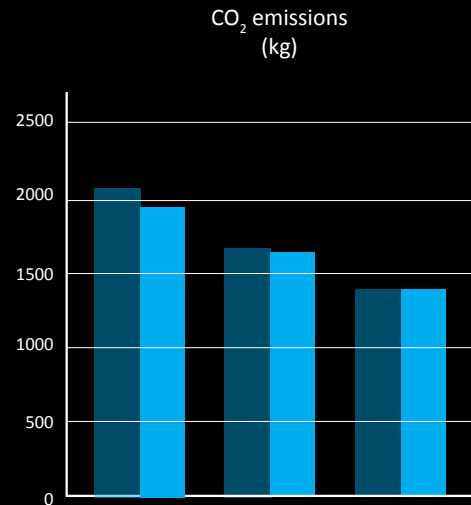
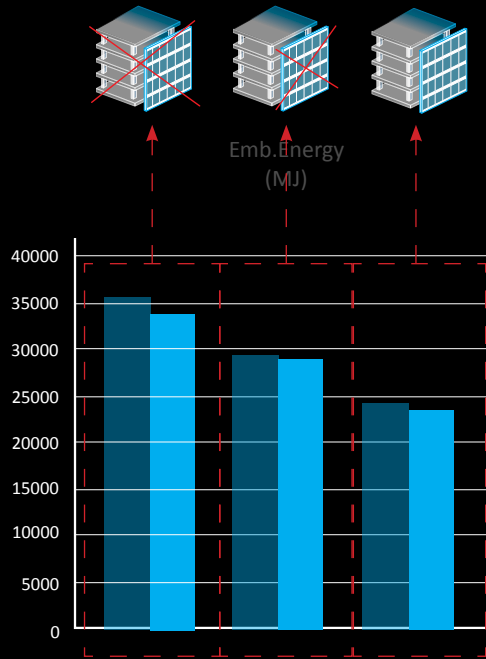

## Comparison of Results

Glazing: triple

Refurbishments: 2

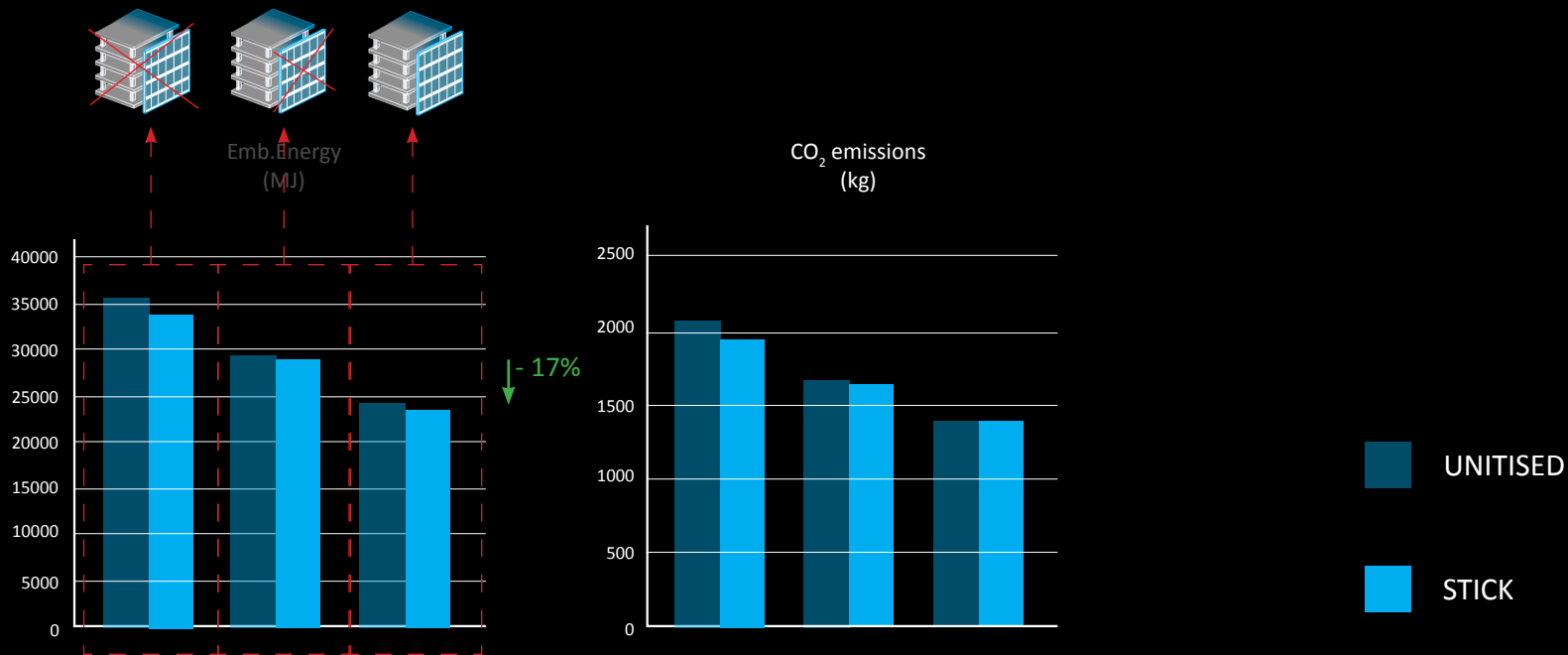

## Comparison of Results

Glazing: triple

Refurbishments: 2

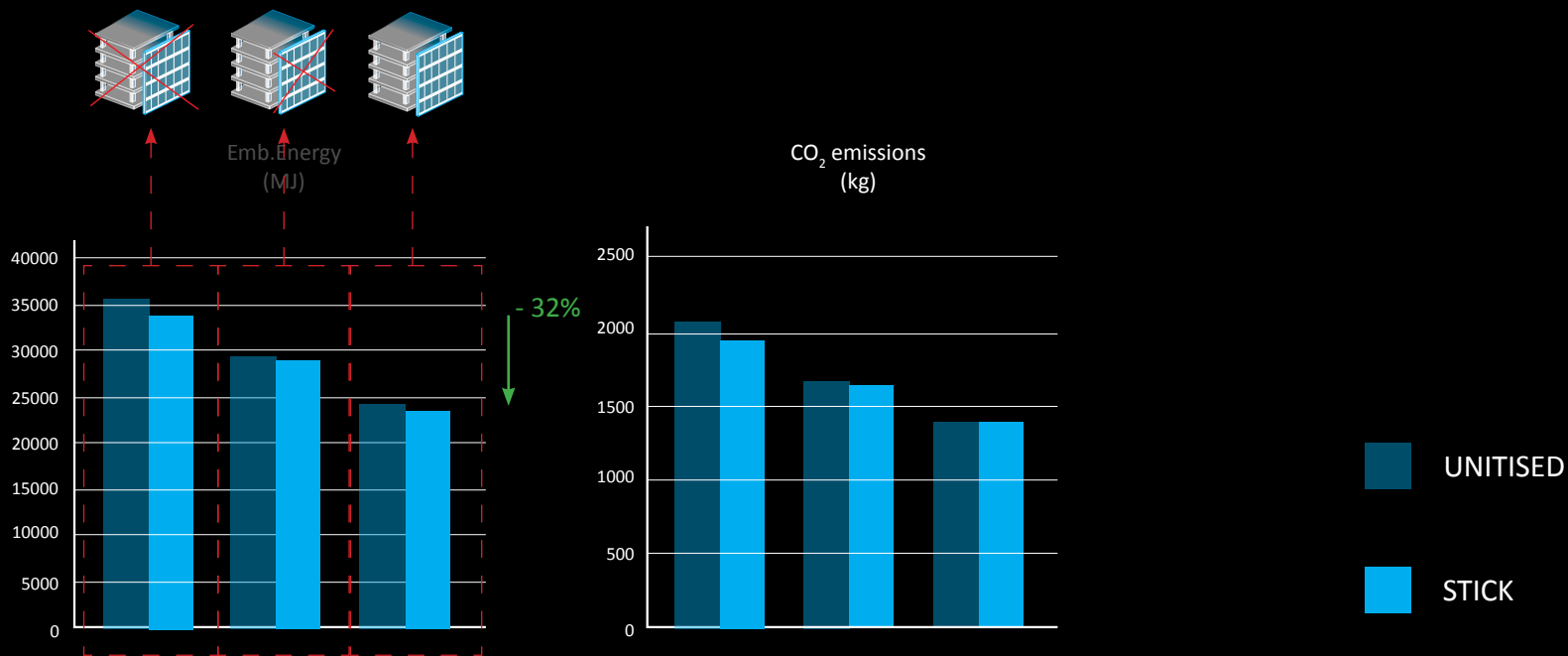

## Comparison of Results

Glazing: triple

Refurbishments: 2

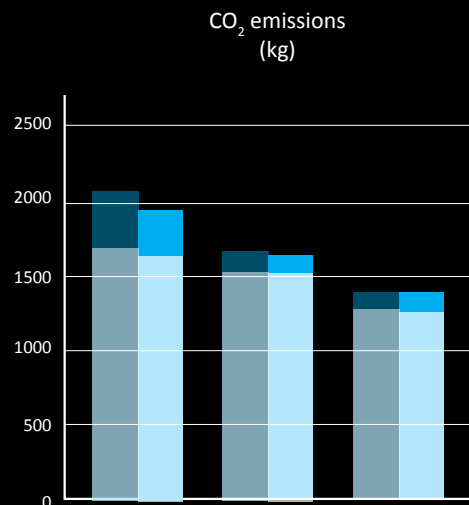
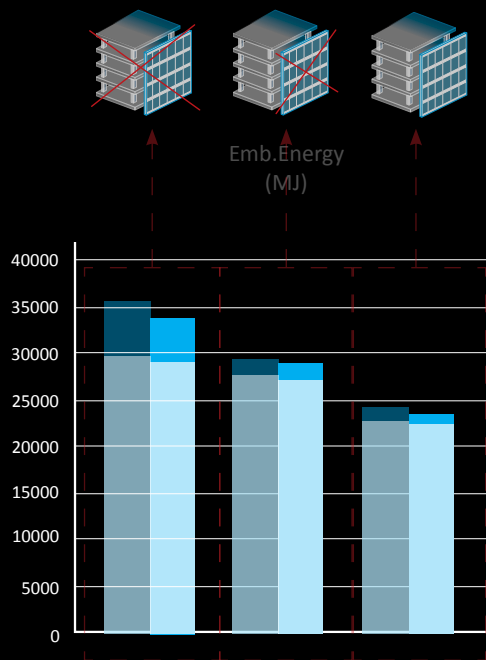

## Cost - Time

### Primary Cost

Facade system / Primary cost (€)	Double glazing	Triple glazing
Stick 15 years Service Life	279.30	392.46
Stick 60 years Service Life	-	404.59
Unitised	288.25	401.41

## Cost - Time

### Primary Cost

Facade system / Primary cost (€)	Double glazing	Triple glazing
Stick 15 years Service Life	279.30	392.46
Stick 60 years Service Life	-	404.59
Unitised	288.25	401.41

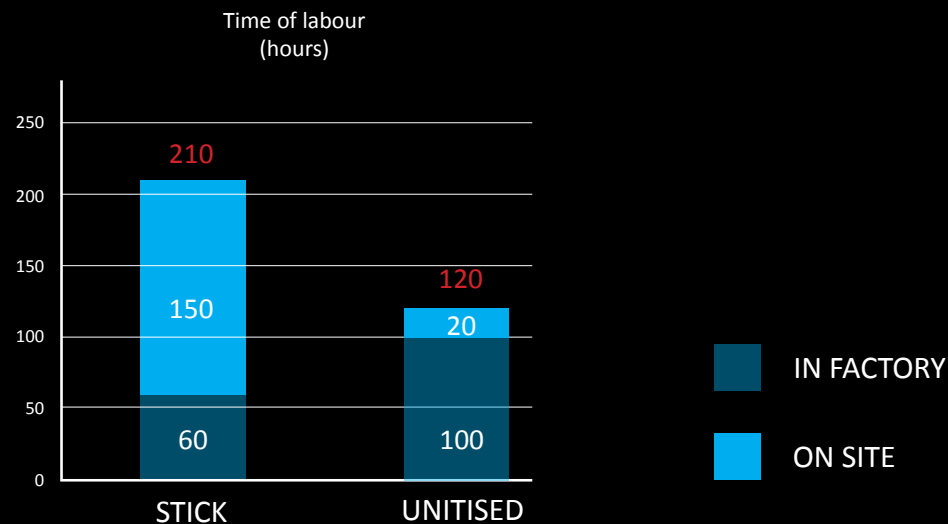

## Cost - Time

### Primary Cost

Facade system / Primary cost (€)	Double glazing	Triple glazing
Stick 15 years Service Life	279.30	392.46
Stick 60 years Service Life	-	404.59
Unitised	288.25	401.41

TIME = MONEY

UNITISED → + 40 h in factory  
- 130 h on site

- 90 h in total

↓  
less labour  
better conditions  
better quality  
less expenses

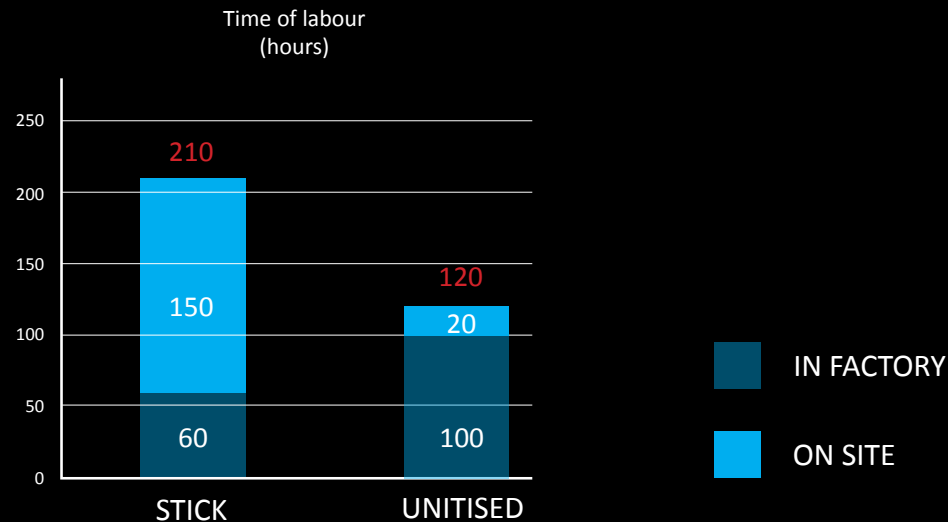

Design matters...





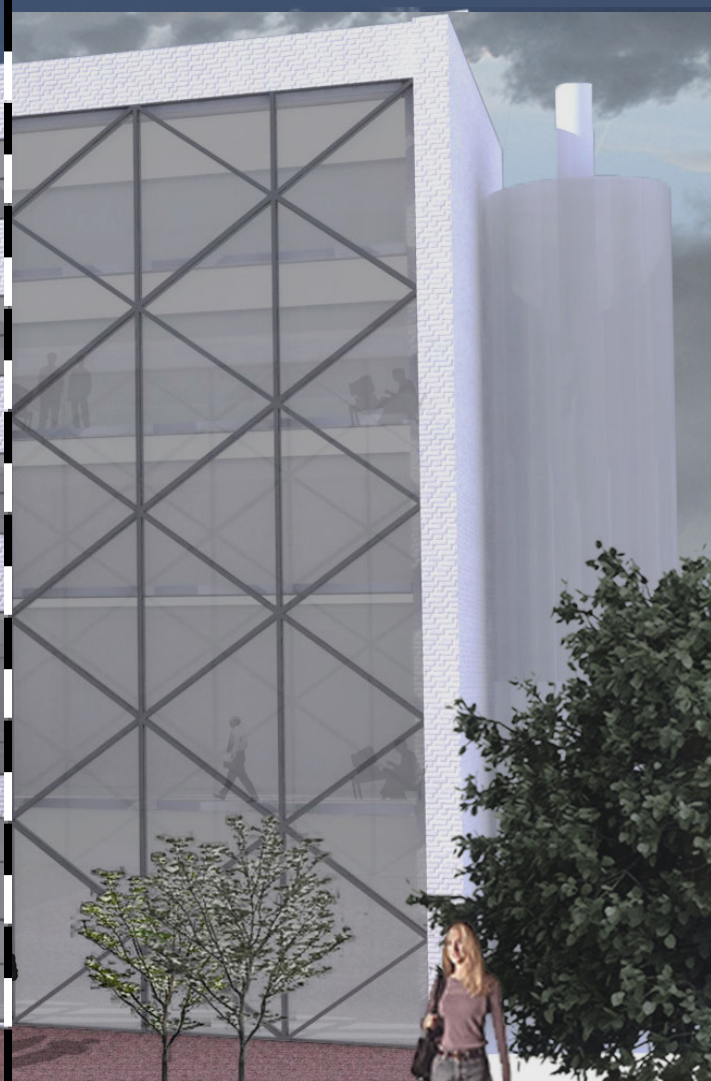
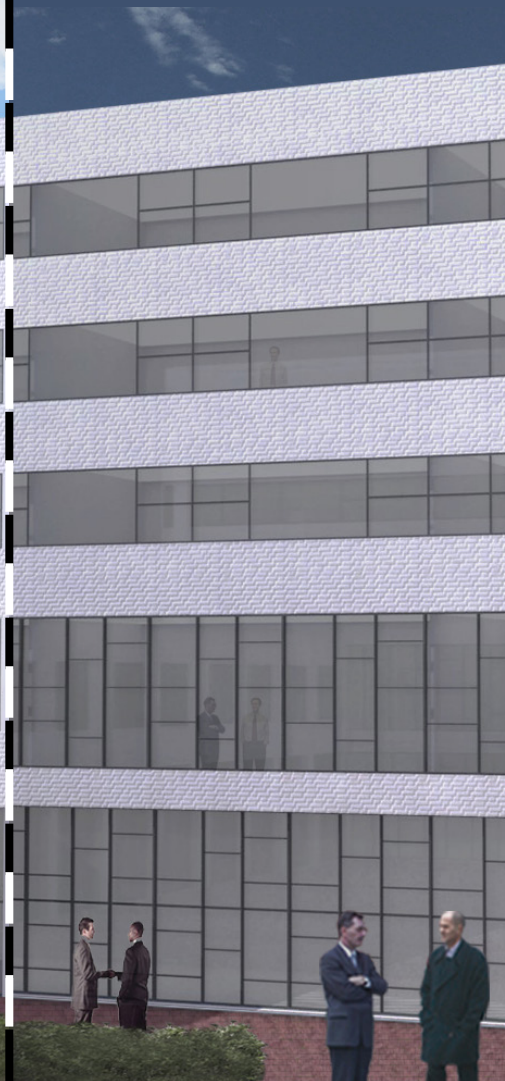

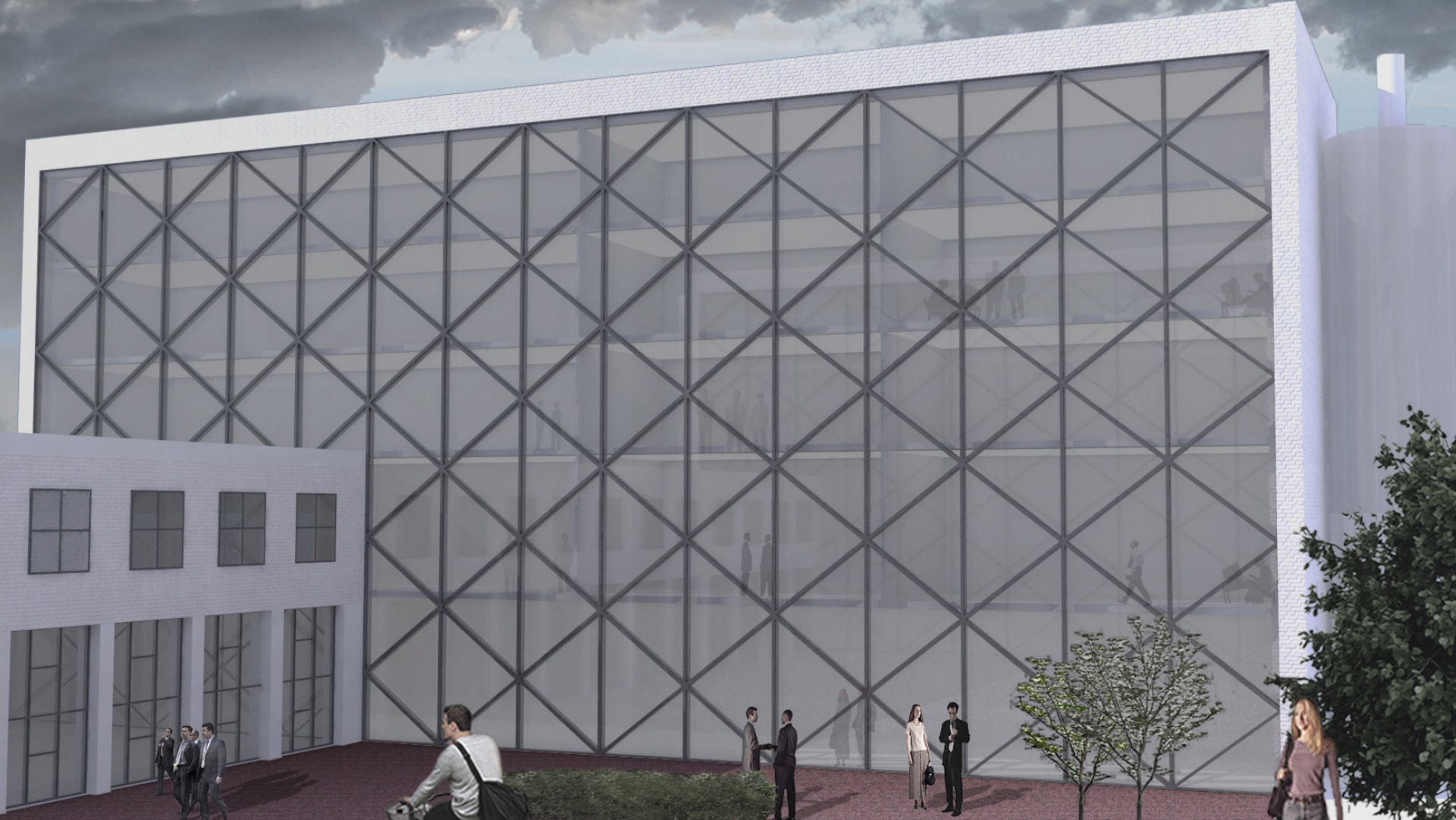

- Both stick and unitised facade have approximately the same environmental impact

- Both stick and unitised facade have approximately the same environmental impact
- Unitised system provides better working conditions and saves a lot of time and expenses
- Stick system requires more time and costs and daily transportation, as most of the work is done on site

- Both stick and unitised facade have approximately the same environmental impact
- Unitised system provides better working conditions and saves a lot of time and expenses
- Stick system requires more time and costs and daily transportation, as most of the work is done on site



Advantage of  
element facade

- Both stick and unitised facade have approximately the same environmental impact
- Unitised system provides better working conditions and saves a lot of time and expenses
- Stick system requires more time and costs and daily transportation, as most of the work is done on site



Advantage of  
element facade

- **Long-term service life** should be applied on façades, and refurbish when needed (currently not applied)

*Thank you for your attention!*

*Questions?*