





Luchtfoto Vlaardingen centrum

INOS

ILMARCHIEF

NO -

52 - 15 - 223



Museum Vlaardingen

'Aring uit Vlârding

Restauratie en uitbreiding van
het "Huis met den Lindeboom"
in de context van historisch Vlaardingen.

E.C. van der A | 1256521
AR4AX300 | 07.11.2012

Mentoren: H.C. Brouwer | E.J.G.C. van Dooren
A.J. van Bommel | | Gecommitteerde: D. Vitner



School haring



Middeleeuwse haringvissers



“Huis met den Lindeboom” aan de haven

Gezicht van de Oostzyde der Stede Vlaardingen door JC Philips en C Pronk, 1745

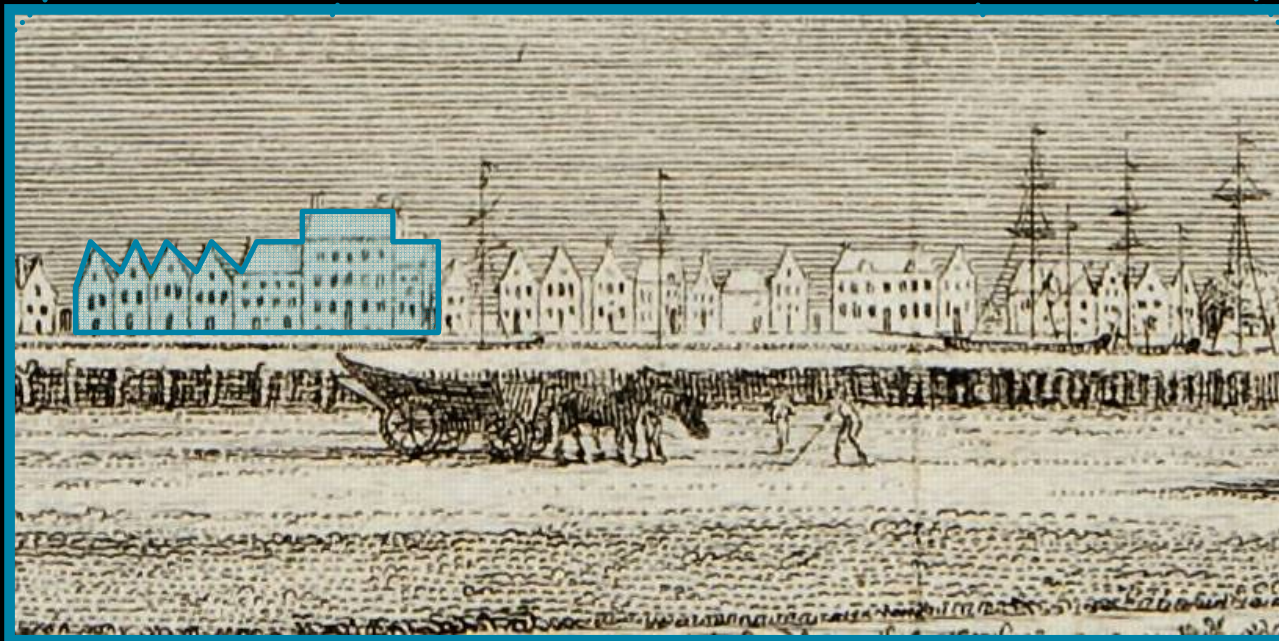
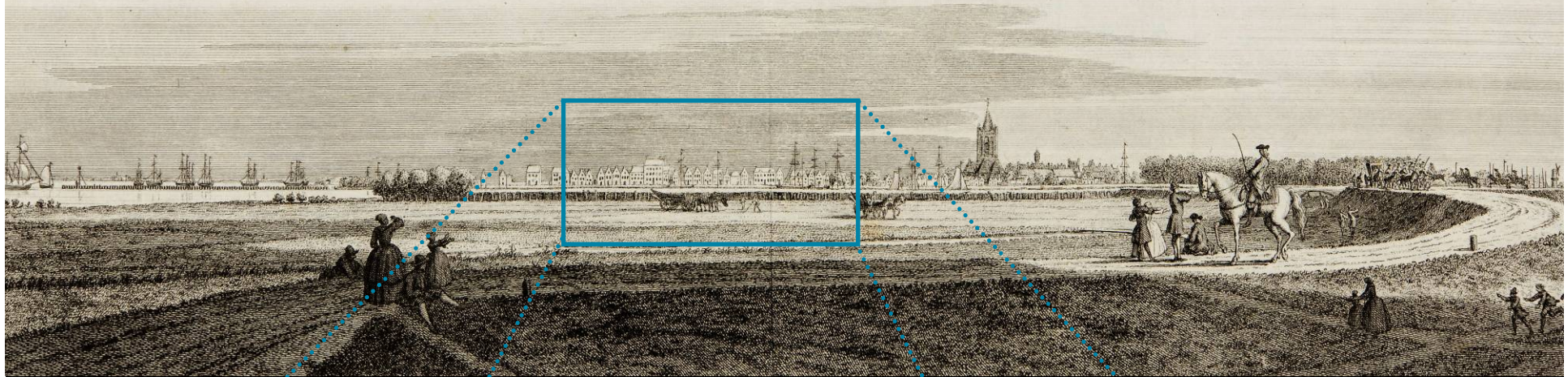

, 2004; DSP-Groep, 2011; Hemei, 1987; Hooper-Greenhill, 1995; interview met Marc Rosmalen, 2011; Interview met Wilbert Weber, 2011) Klausner, 2010; Lampugnani en S 05; MacLeod, 2005; Matthews, 1991; Von Naredi-Raider, 2004; Rodermond et al., 1 ndell en Janes, 2007; Van de Ven, 1987; Wolfsen, 2007).



Musea worden door sommigen ge- als *“a treasure trove of art, a temp the nine muses”*, terwijl and musea juist negatief als een : begraafplaats zien, *“truly identic their sinister juxtaposition of b that do not know each other”* (Y Lee, 1997; Zeiger, 2005).

ingezien het museum is ontstaan voor het publiek en dus ook een dienende rol heeft, i n relatie met de omgeving, de context en de maatschappij onontkoombaar. Grahar ward (2008) zijn dat ook van mening dat musea een belangrijke plaats innemen i entiteit van een land, van een gebied, van een stad, maar tegelijk ook een afspiegeling zijr n familie of zelfs van een persoon. Door dit soort relaties actief te accentueren. zal

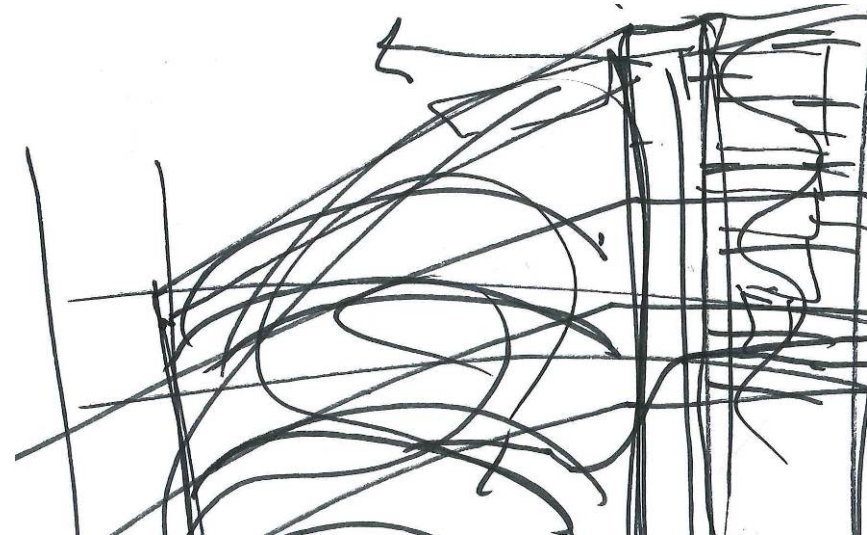

Onderzoek

Ontwerp



Museum



Restauratie



Vlaardingen



Redershuis



Museum



Restauratie

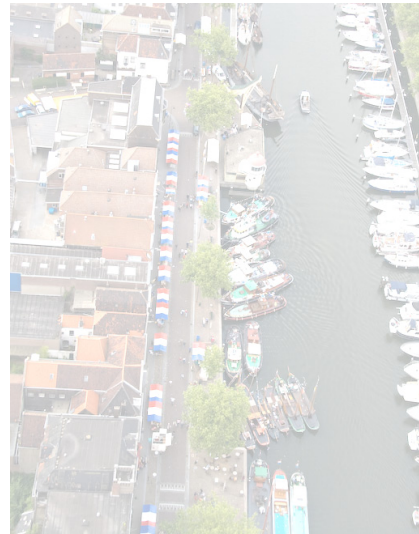

Vlaardingen



Redershuis

*“We need museums that are themselves **exciting** to see, architectural works whose **beauty** compels us even as they **efface** themselves behind the **beauty of art.**”*

– Douglas Davis

museum: *instituut van verzameling van erfgoed getoond aan publiek*

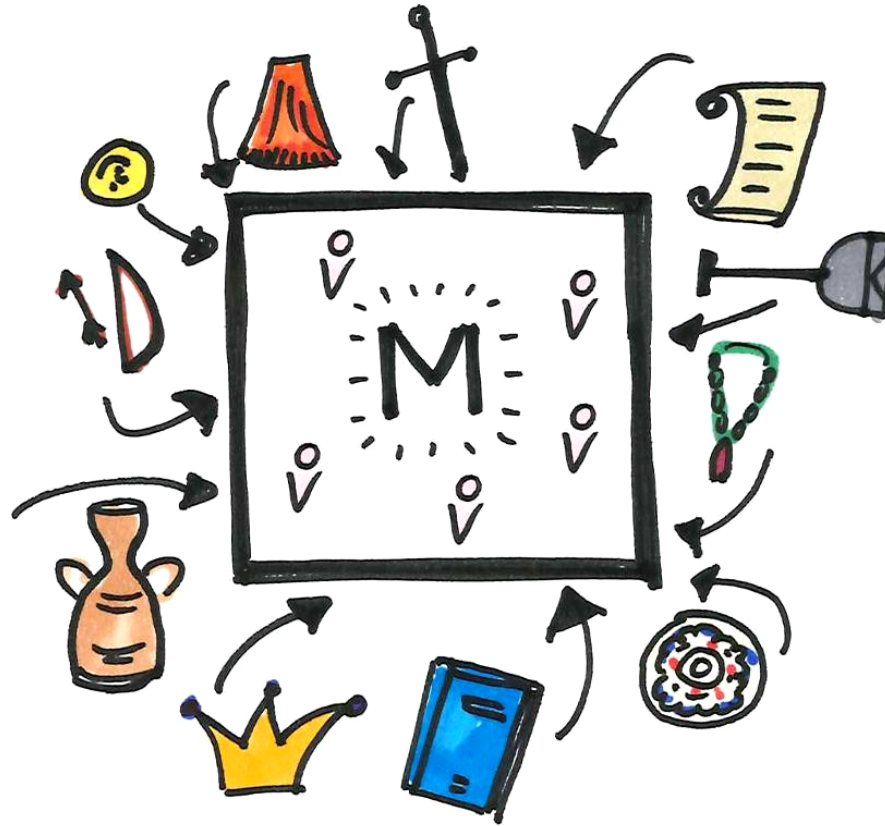

- kunst
- geschiedenis
- maritiem
- militair
- wetenschap
- sterrenkunde
- archeologie
- natuur
- antropologie
- open lucht
- virtueel

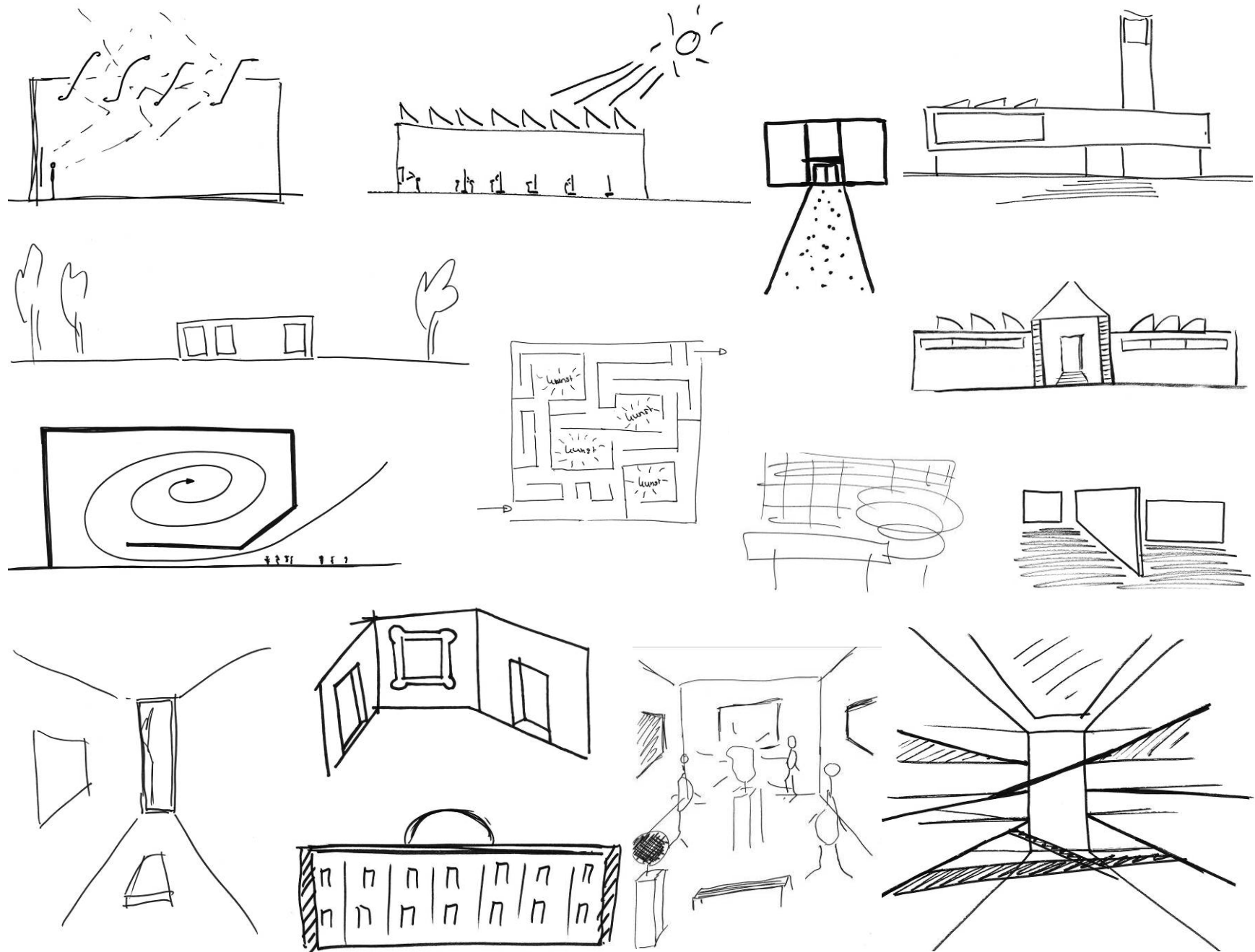

Resultaten van: "Tekenen een museum!"



The British Museum, Londen (VK)



Guggenheim, Bilbao (S)

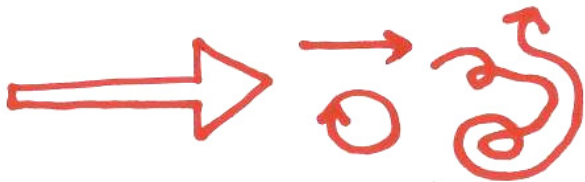

Route

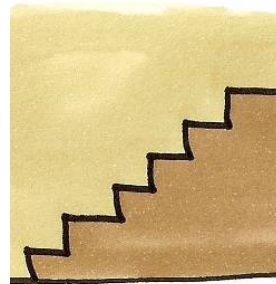

Trappen (verticaliteit)

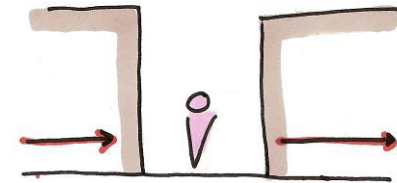

Tussen

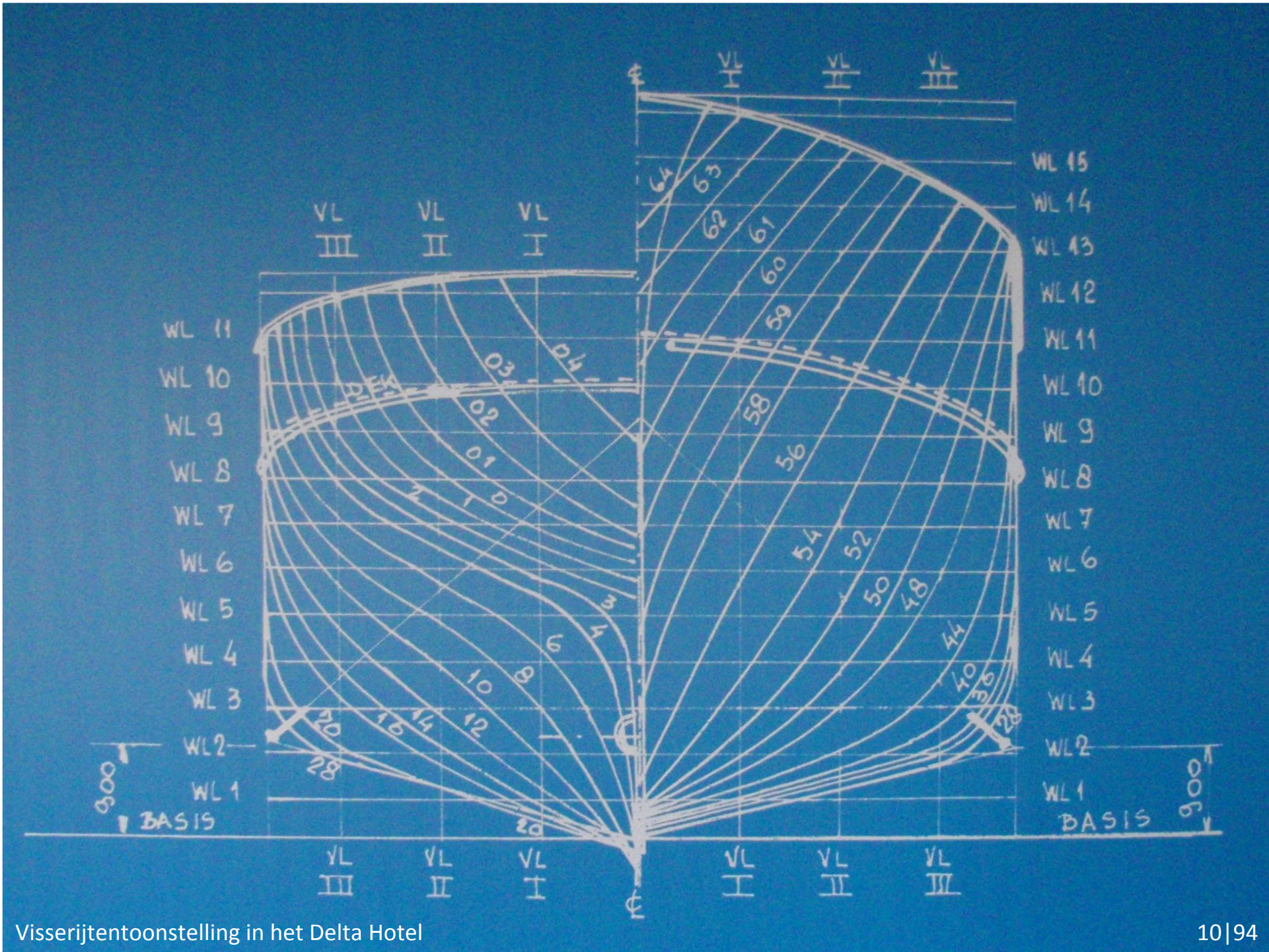



Museum



Restauratie



Vlaardingen



Redershuis

*“Conversion [to a **cultural function**] is important as a means of **revitalizing older, densely built, run-down inner-cities areas.**”*

– Geoff Matthews

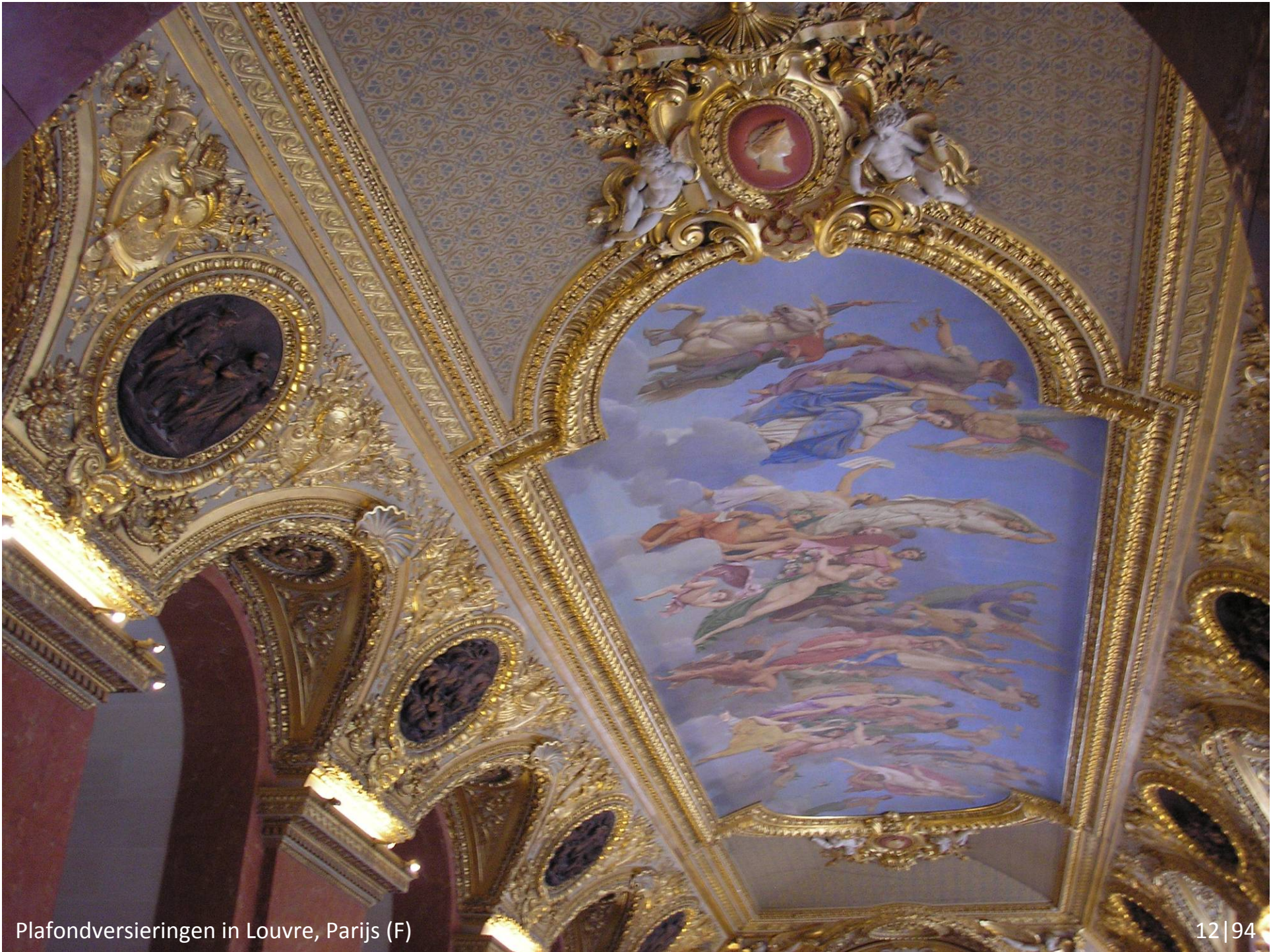

Plafondversieringen in Louvre, Parijs (F)



Loftwoning in New York (VS)

*“Maxima quaeque aedificatio ob vitae
hominis brevitatem et operis magnitudinem
**vix nunquam dabitur, ut per eundem
absolvi possit, qui posuerit.**”*

– Leon Battista Alberti



Castelvechio (I) door Scarpa



Sloop in Vlaardingen na de Tweede Wereldoorlog

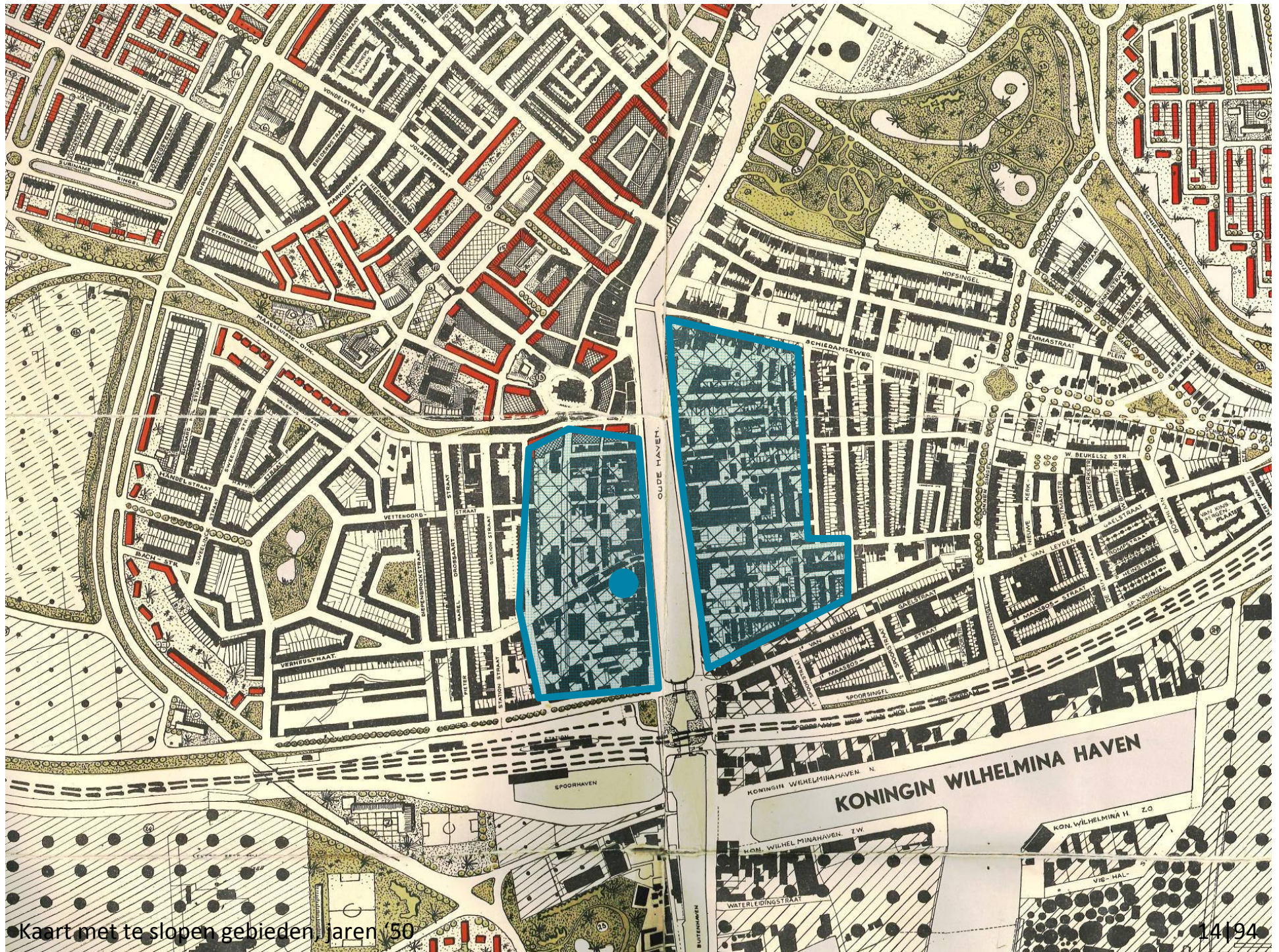

•Kaart met te slopen gebieden jaren '50



Één thema

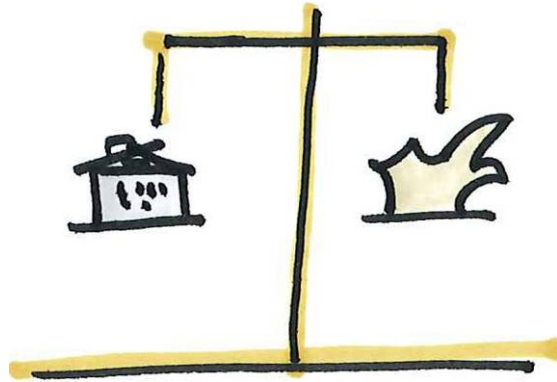

Balans oud-nieuw

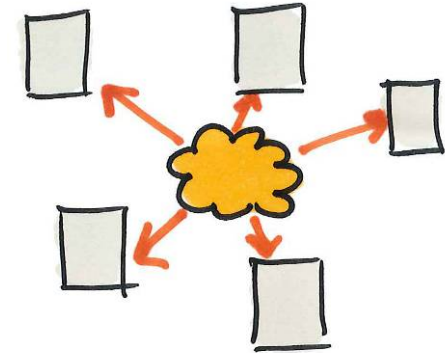

Organisatie vanuit nieuwbouw



muZEEum in Vlissingen



Museum



Restauratie



Vlaardingen



Redershuis

*“Al zijn er dan nu **geen vissersschepen** meer die op zee haring bevissen, de aanduiding ‘**Haringstad**’ gaat voor **Vlaardingen** toch nog steeds op.”*

– uit ‘Over haring en zout’

Het vertrouwde adres - Eigen vloot van 10 schepen
N.V. VAN TOOR'S HANDELMAATSCHAPPIJ
OOSTHAVENKADE 89 - VLAARDINGEN



*de echte
Hollandsche Maatjes
zijn er nu!*

VLOEIBLAD

TELEFOON
Nr 73
VLAARDINGEN

GIRO
Nr 44169

De fijnste Nieuwe Naring komt van VAN TOOR uit Vlaaring

SMAKELIJK EN GEZOND

Ook in kleine vaatjes en blikverpakking, franco huis

Auteursrecht N.V. Duikerij Van Oosten Vlaardingen

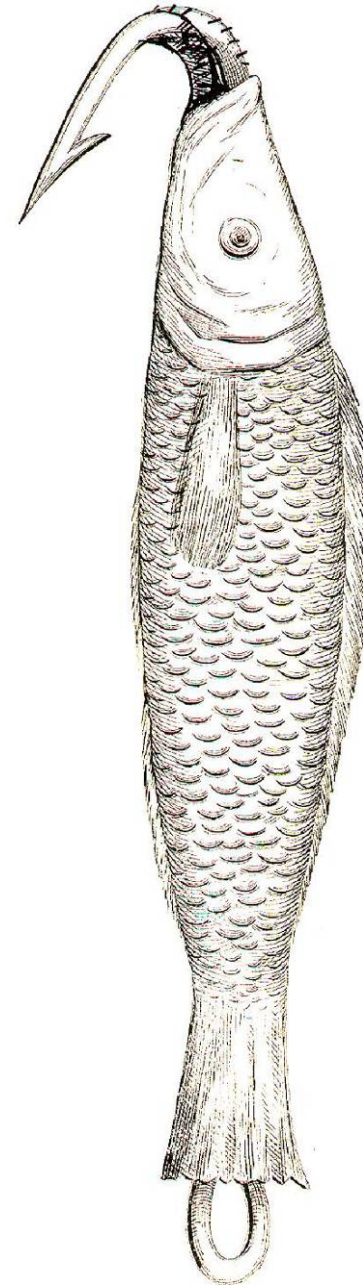



Haven van Vlaardingen

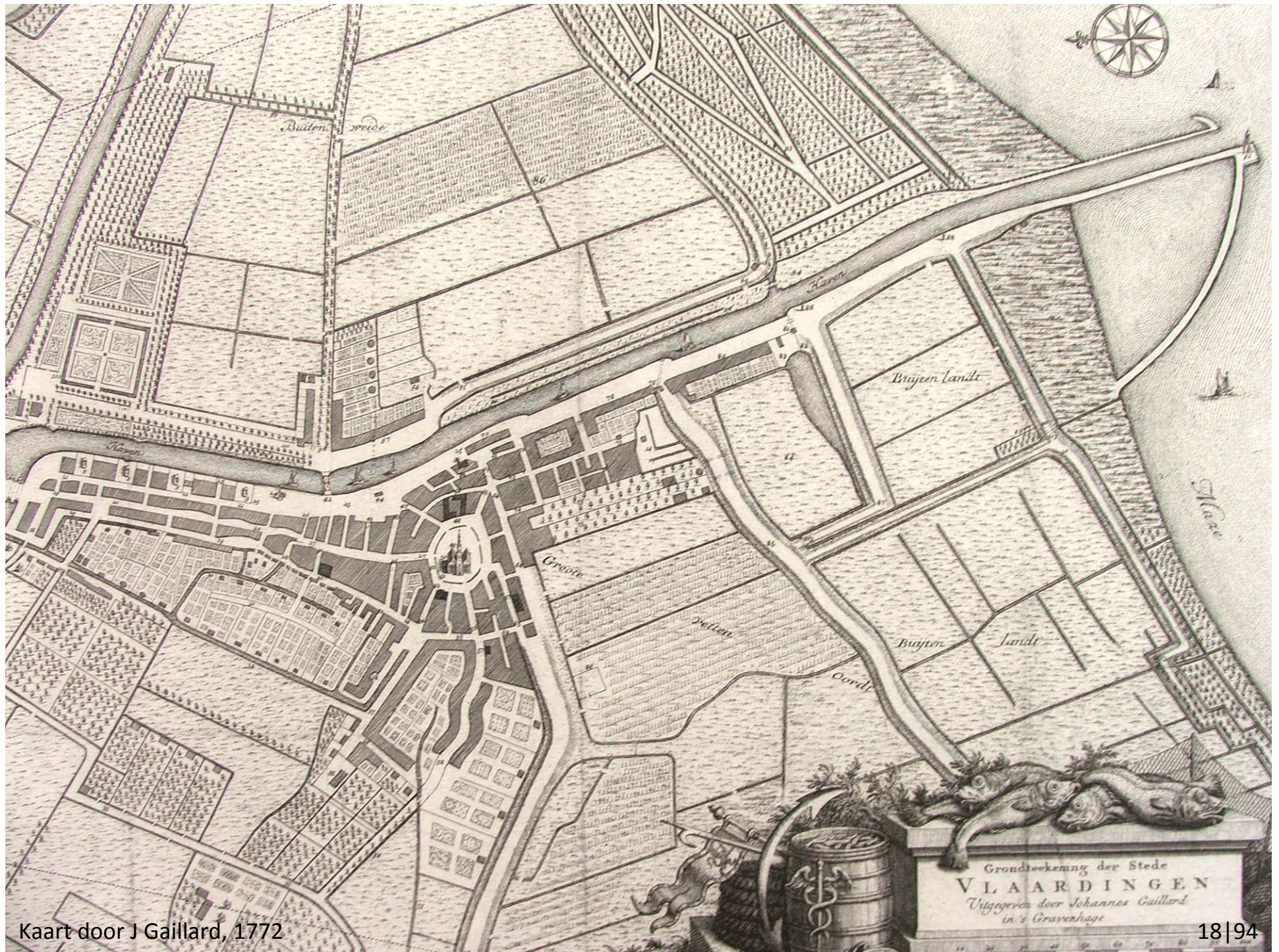

Kaart door J Gaillard, 1772



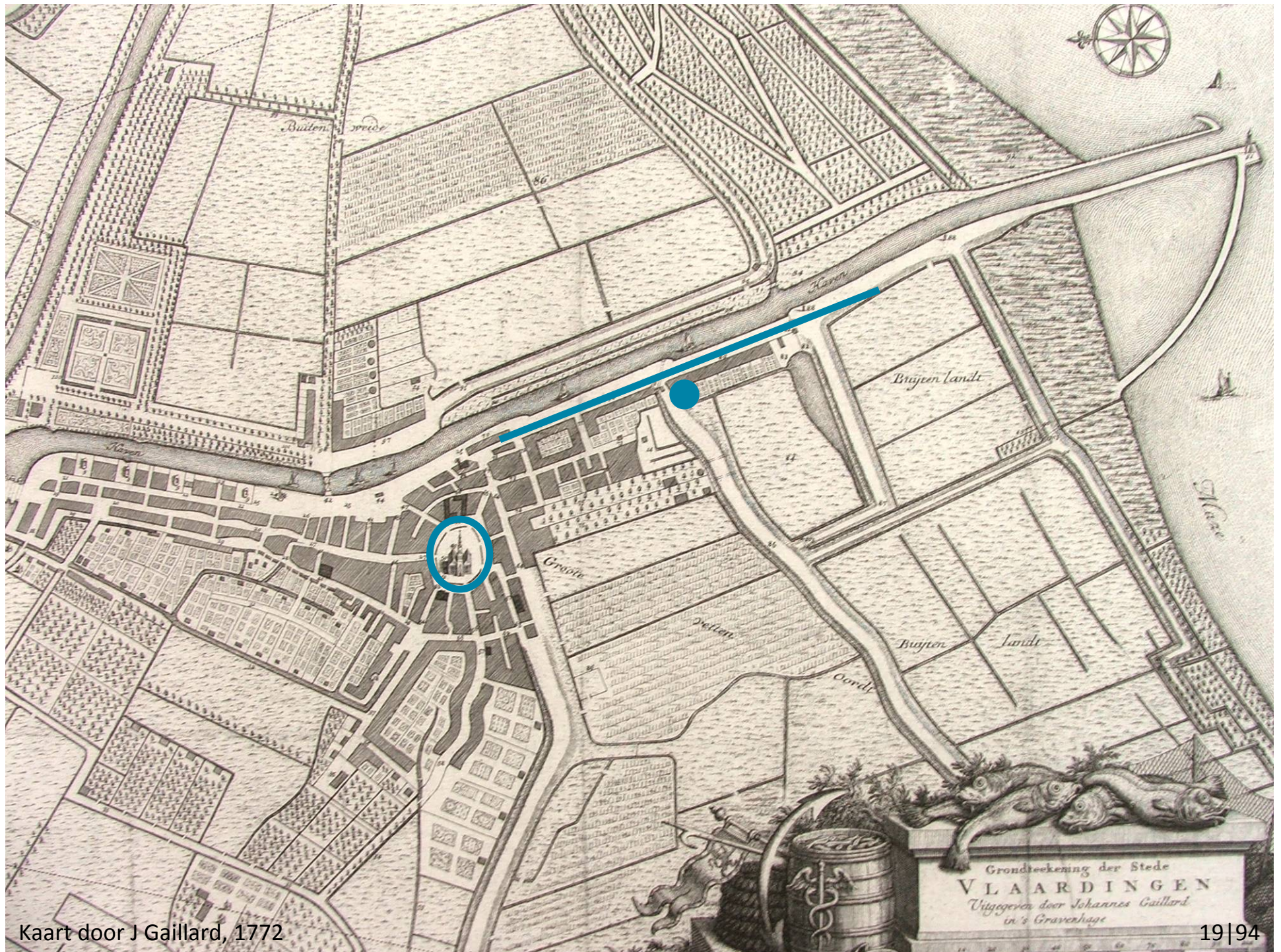

Kaart door J Gaillard, 1772





Uitladen van de schepen aan de haven



Eerste haringvervoer met auto, 1927

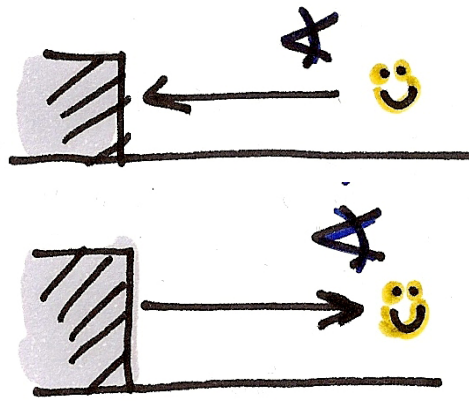

Zicht op/van gebouw

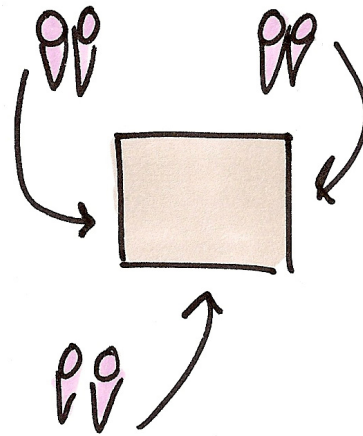

Samenkomst als extra functie

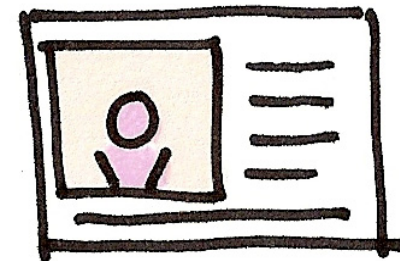

Geliefd door identiteit

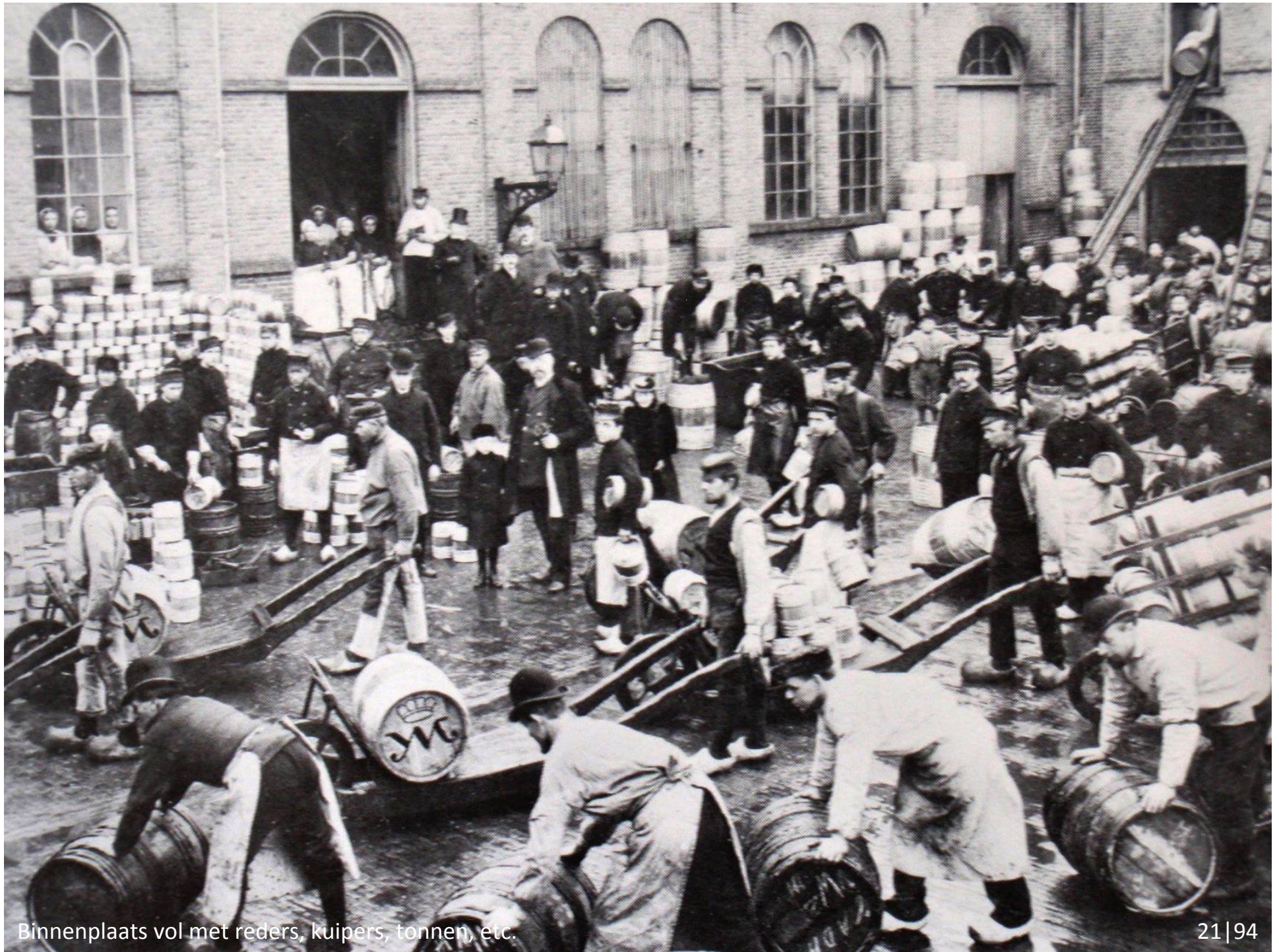

Binnenplaats vol met reders, kuipers, tonnen, etc.



Luchtfoto Vlaardingen



Dr. Wardi Beckmansingel

Groeten uit

Vlaardingen

Hoogstraat

Vliet

Park 't Nieuwland

Burg. de Bornesplein





Redershuis jaren '80



Gebouwencomplex

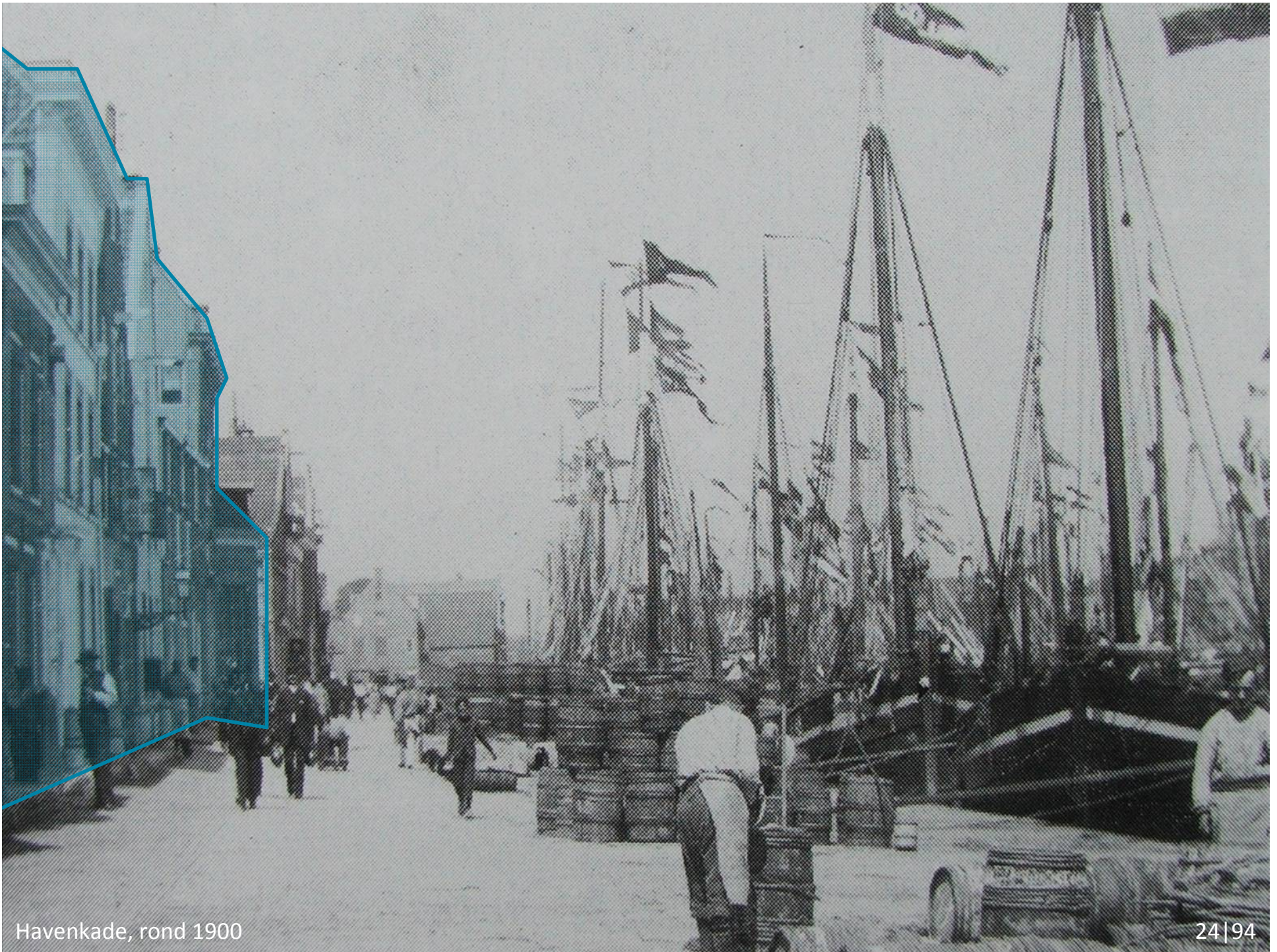

Havenkade, rond 1900

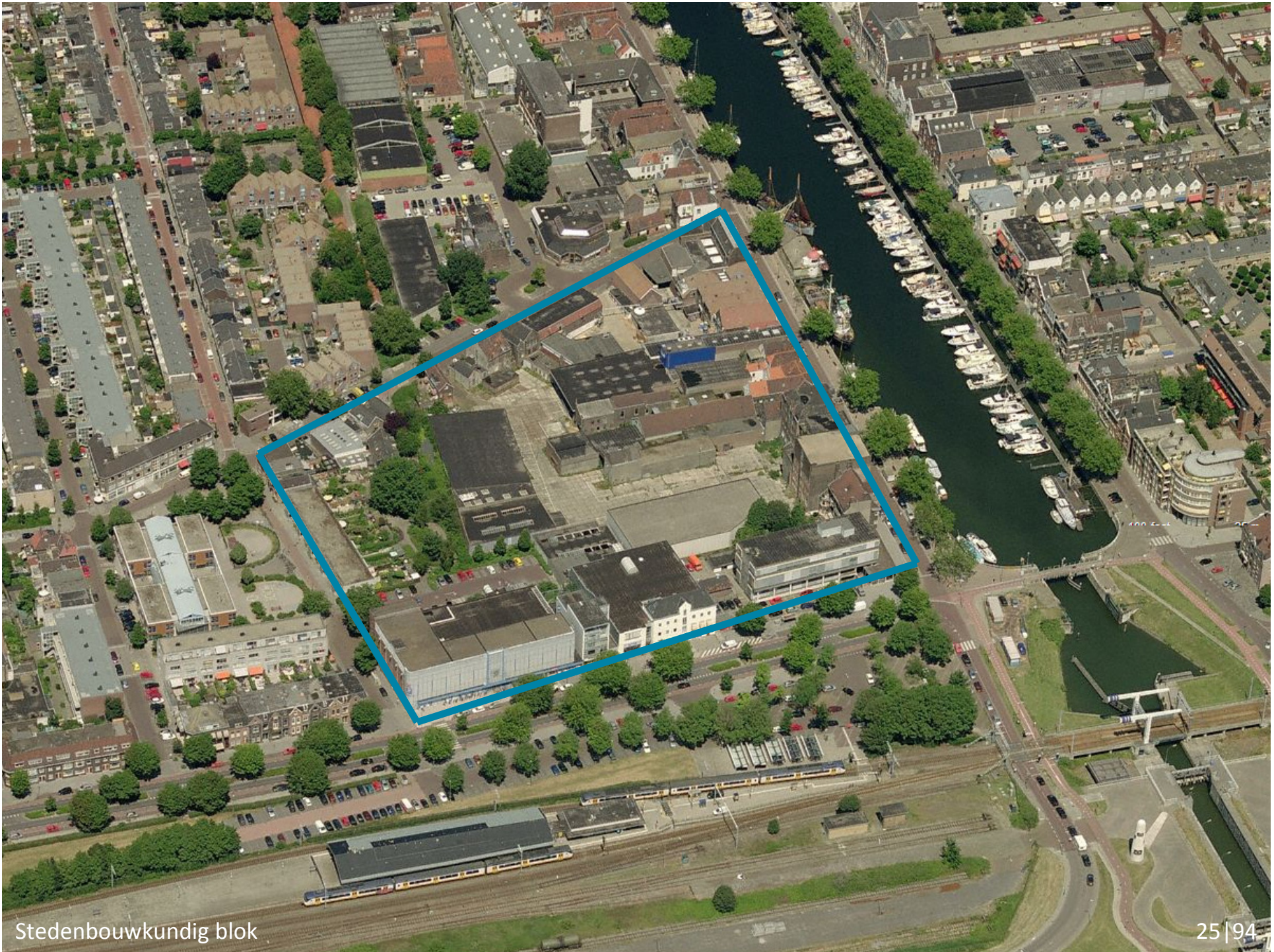

Stedenbouwkundig blok



Touwbaan, rond Interbèlum

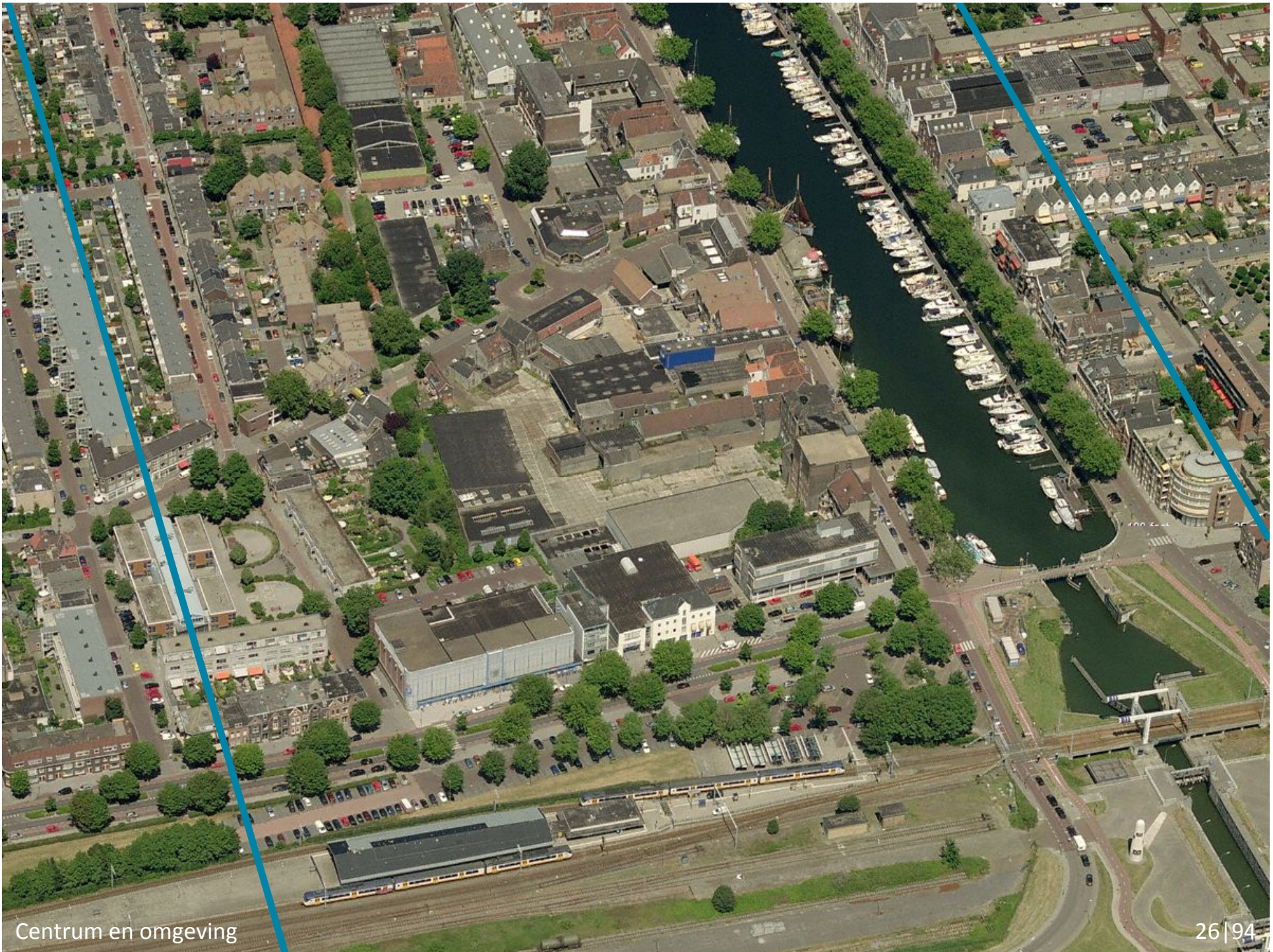





Uitgangspunten:

- Steegjes
- Intiem
- Fijnmazigheid
- Aanhechten

Grijs: bestaand
Bruin: nieuw

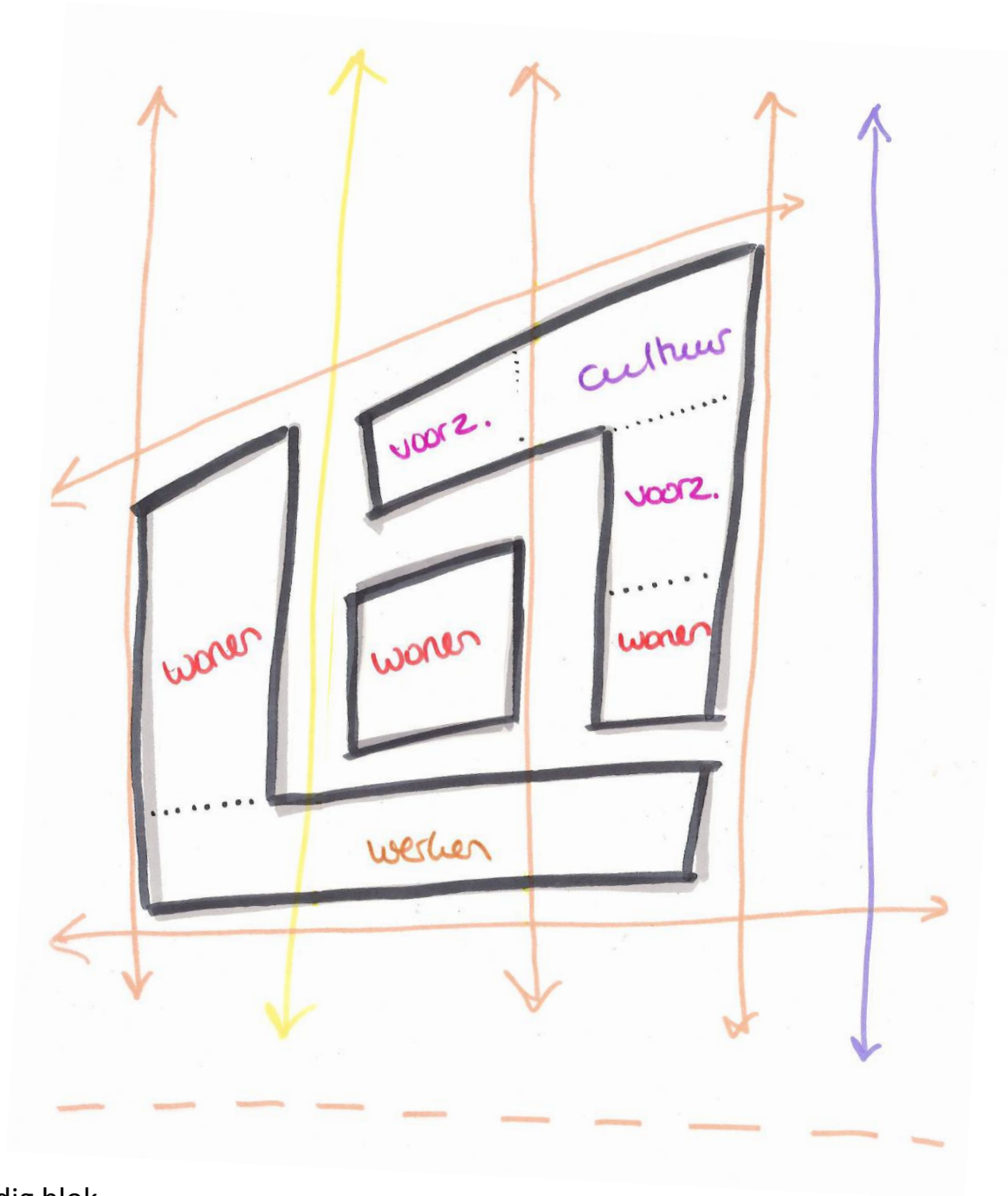



Steeg naast het "Huis met den Lindeboom", rond 1960



De huidige Vetteoordskade

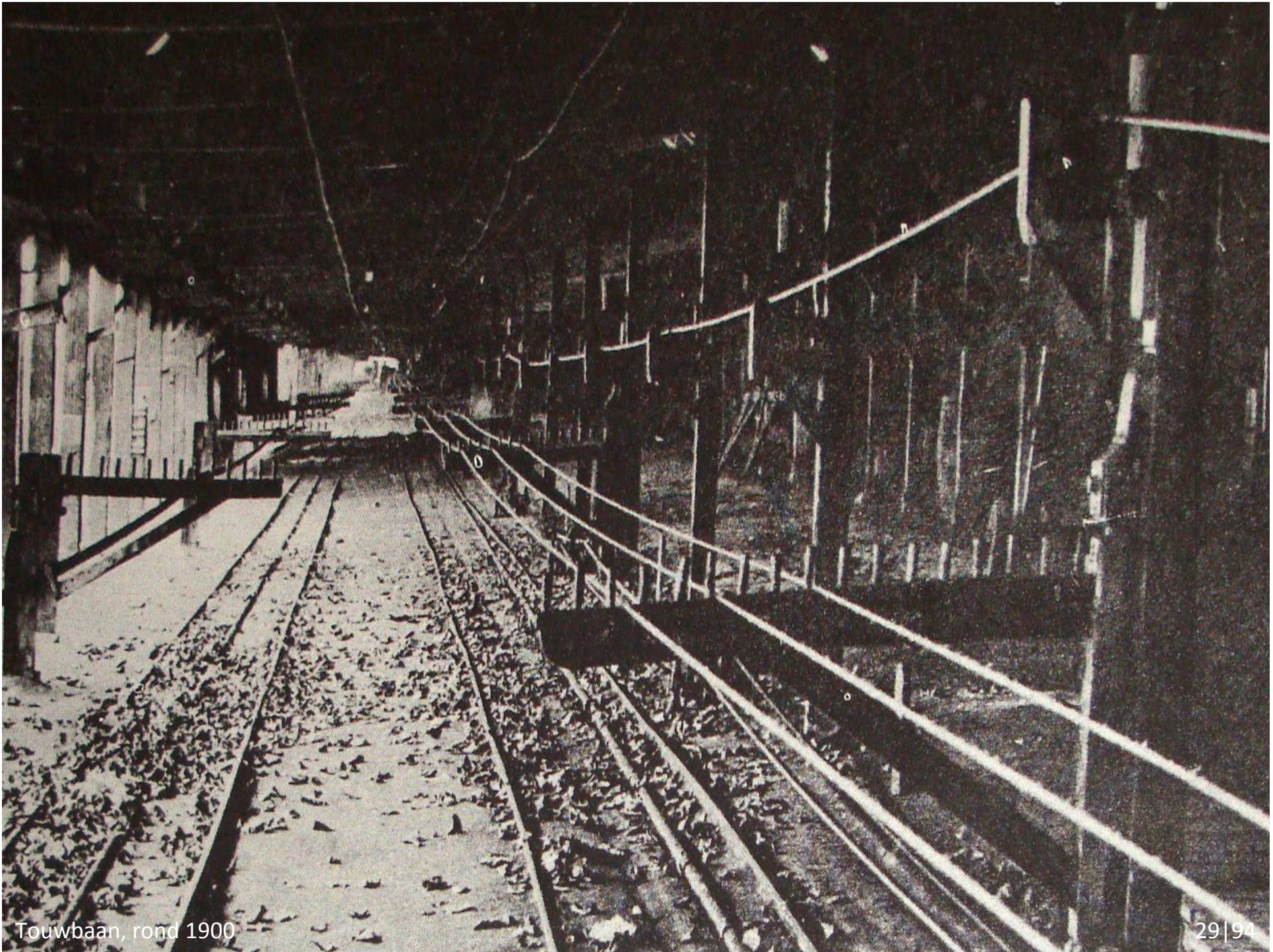

Touwbaan, rond 1900



Huidige Touwbaan



Volle havenkade, rond 1930



Huidige openbare ruimte

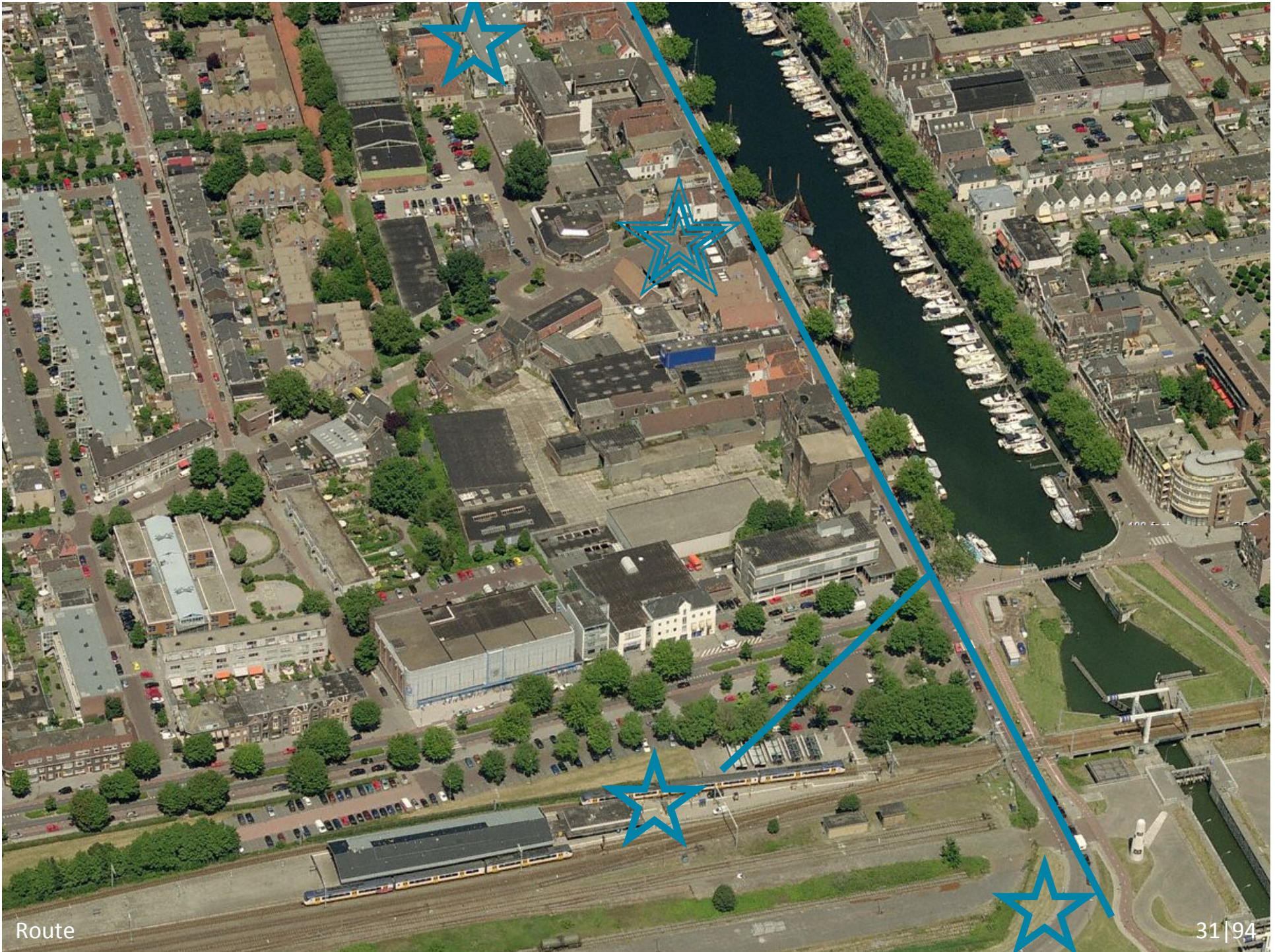

Route



Pakhuizen en redershuizen rond 1930



Museum



Restauratie

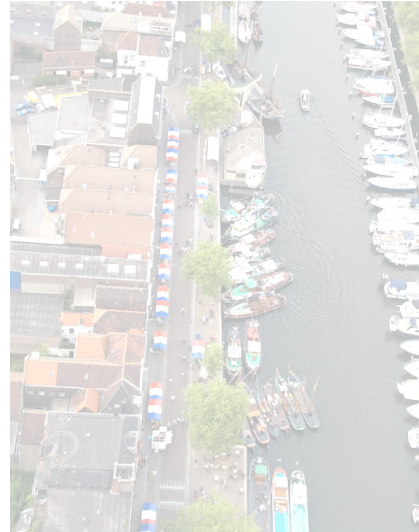

Vlaardingen



Redershuis

*“Van der Linden liet zijn erf bebouwen met een ‘**arbeysershuysie en pakhuys**’, zoals onder nummer **A 765** in de lijst van **nieuw gebouwde huizen en pakhuizen** wordt vermeld.”*

– Matthijs Struijs



Burgemeester Van der Linden (1684-1767)

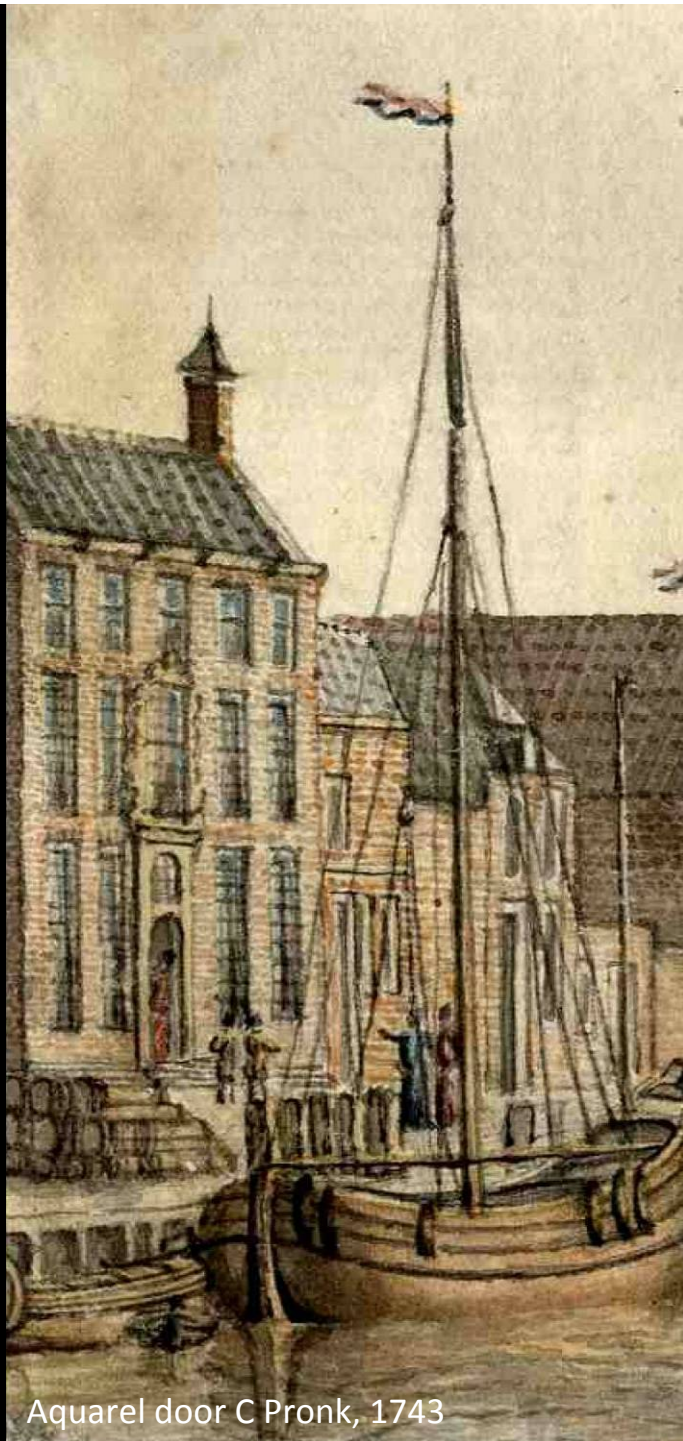

Aquarel door C Pronk, 1743



Gravure door C Pronk, 1745



Zicht op "Huis met den Lindeboom" en andere havengebouwen, 1905

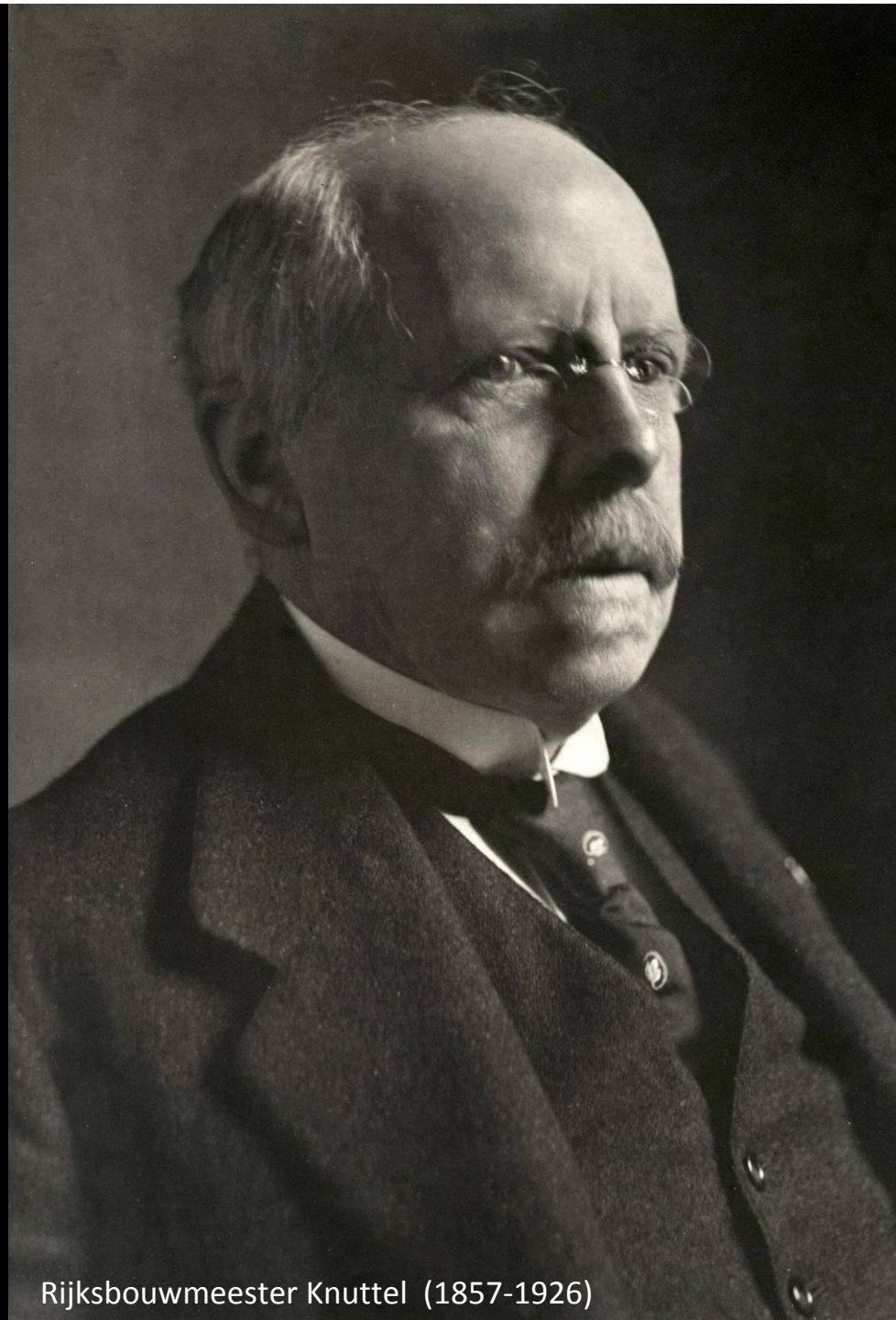

Rijksbouwmeester Knuttel (1857-1926)



Havenzicht, jaren '60



Interieur jaren '70



Interieur jaren '00

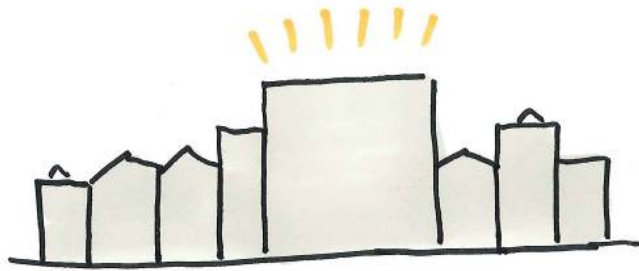

Hoogtepunt in ensemble

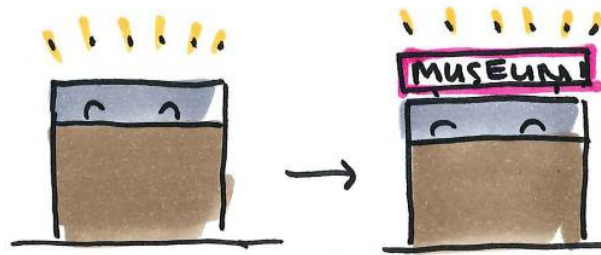

Eerst gebouw, dan museum

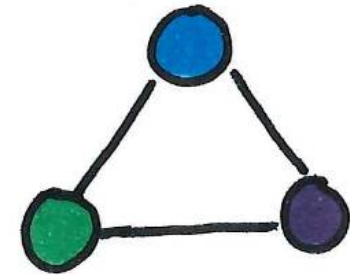

“Driemanschap”



Exterieur en havenzicht, 2009







Zicht Westhavenkade en Vetteoordskade



Haringmedewerkers, rond 1900



Zicht op achtergebied



Binnenplaats, rond 1900

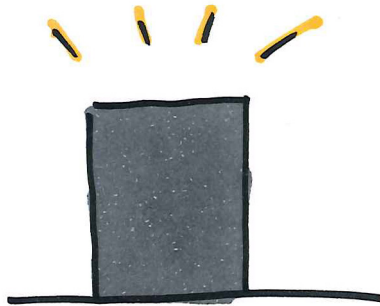

Helderheid

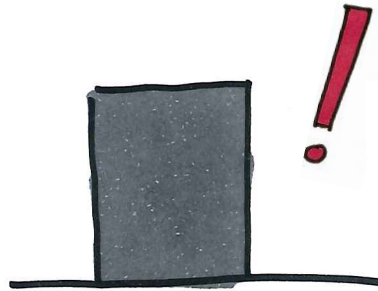

Herkenbaarheid

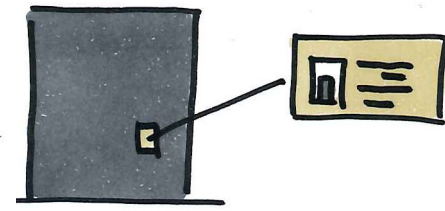

Identiteit

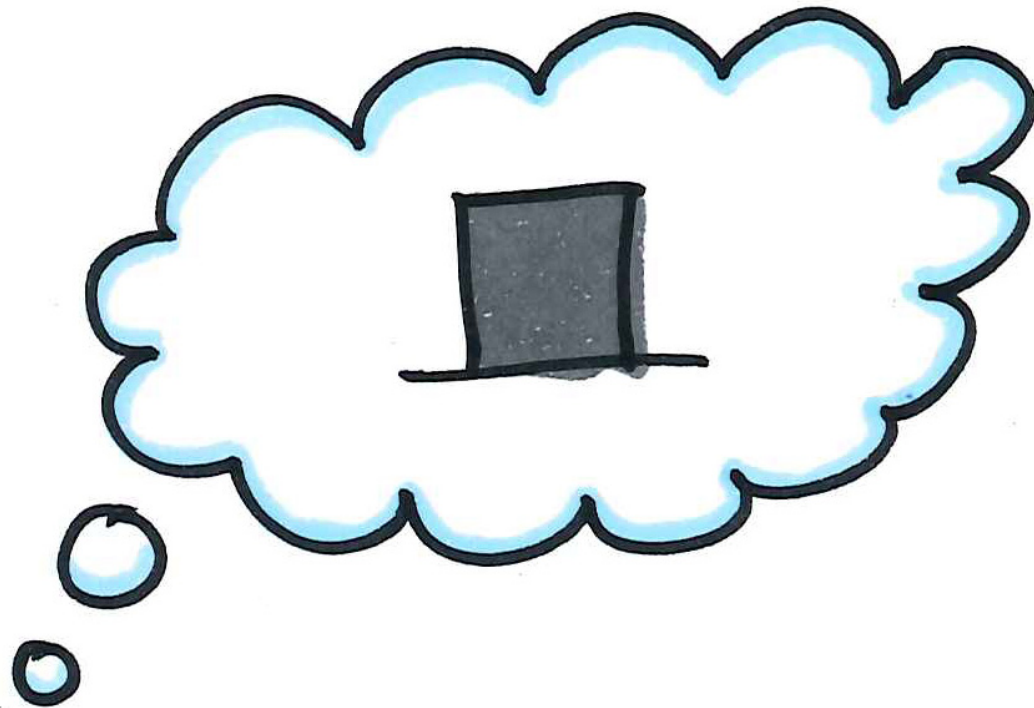

Herinnering

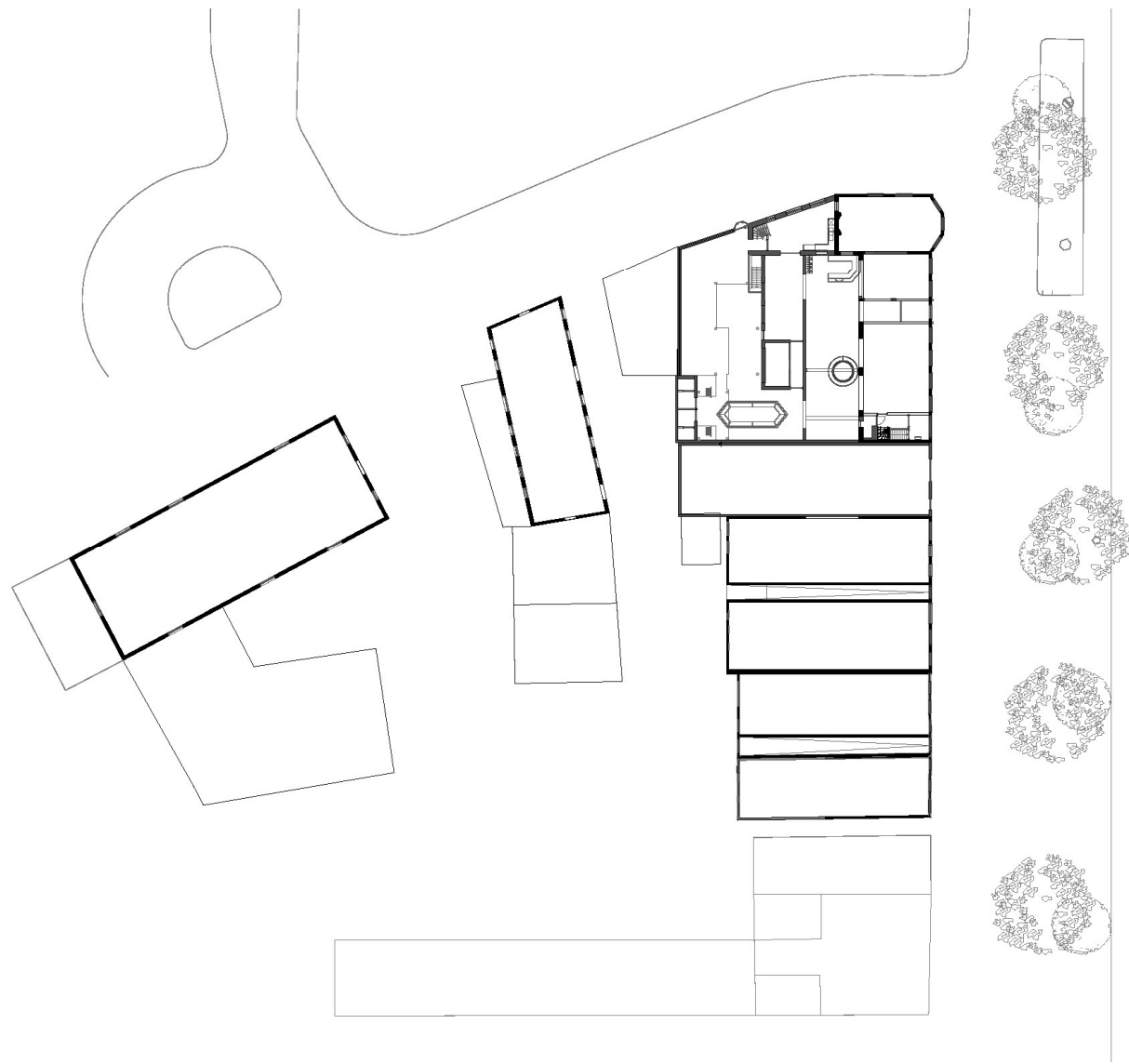



Uitladen van de schepen, voor 1900

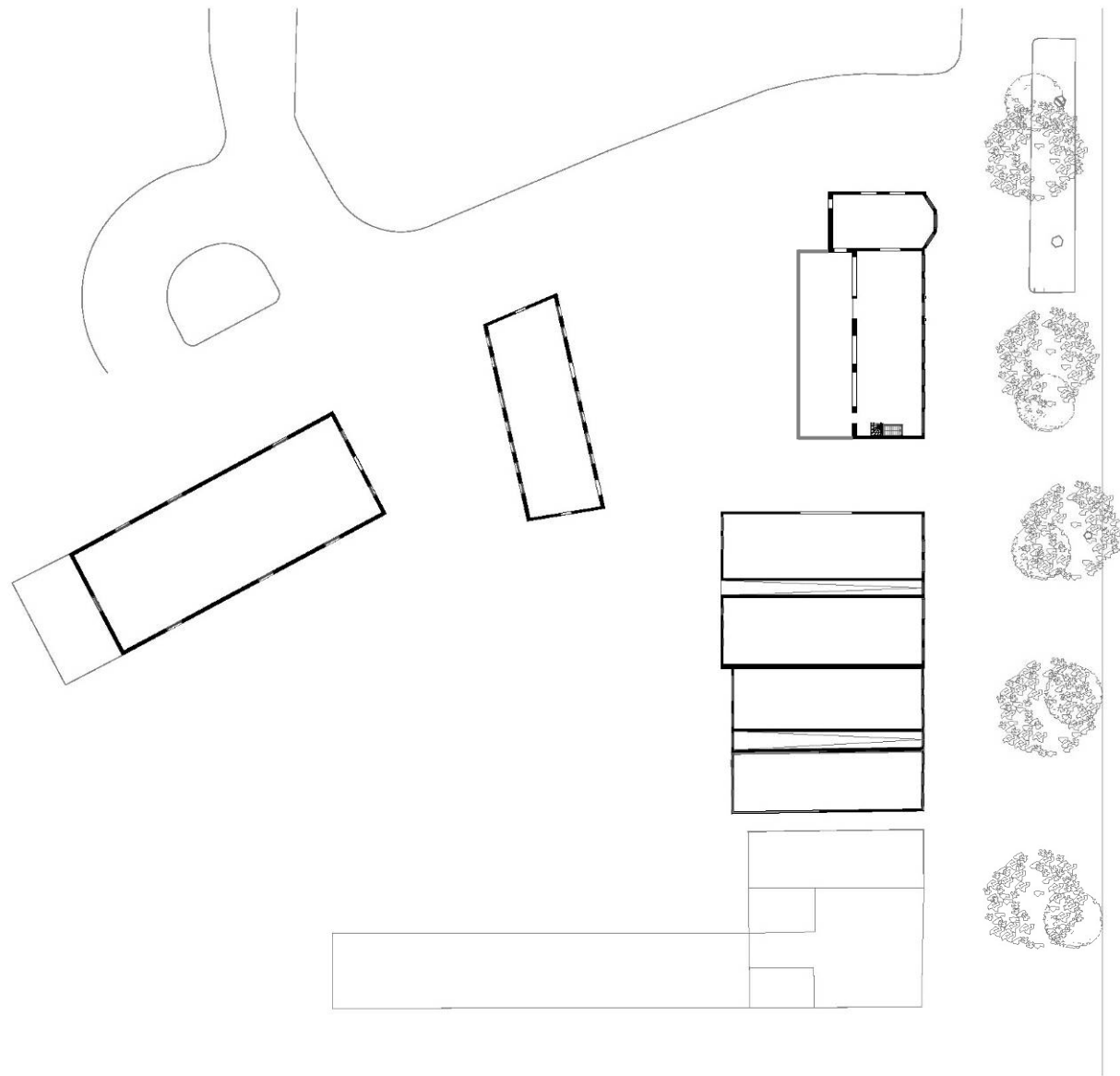



Aanpassingen redershuis in jaren '70

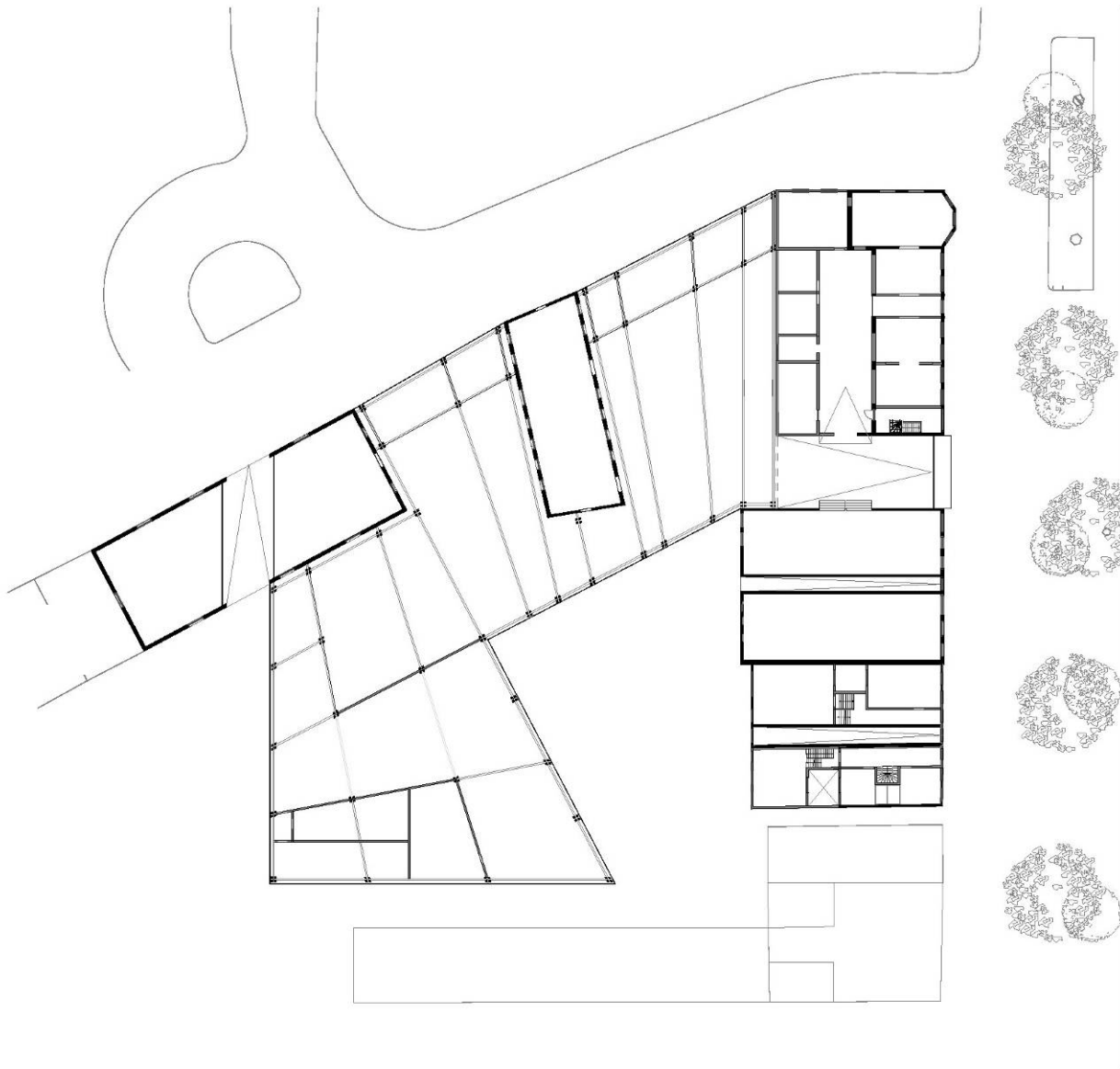

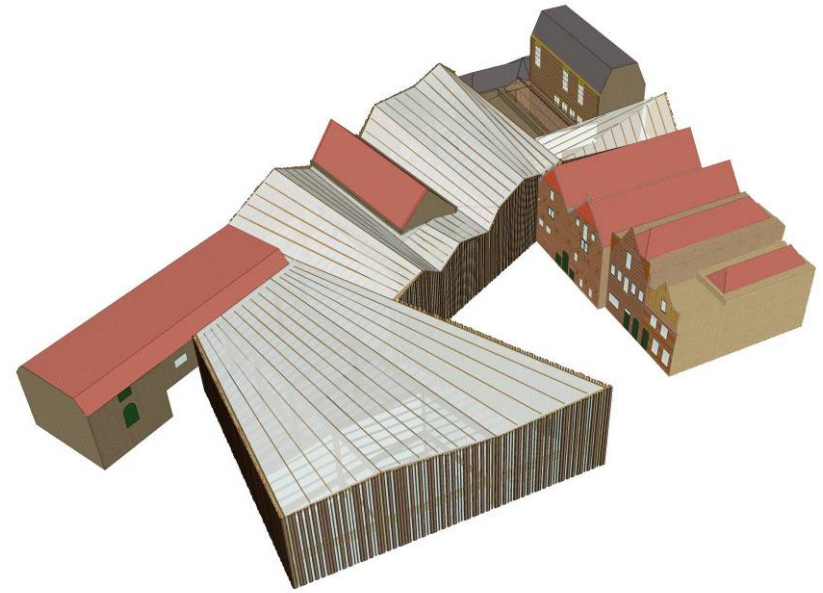

Vogelvlucht vanuit zuid-oosten en vanuit zuid-westen

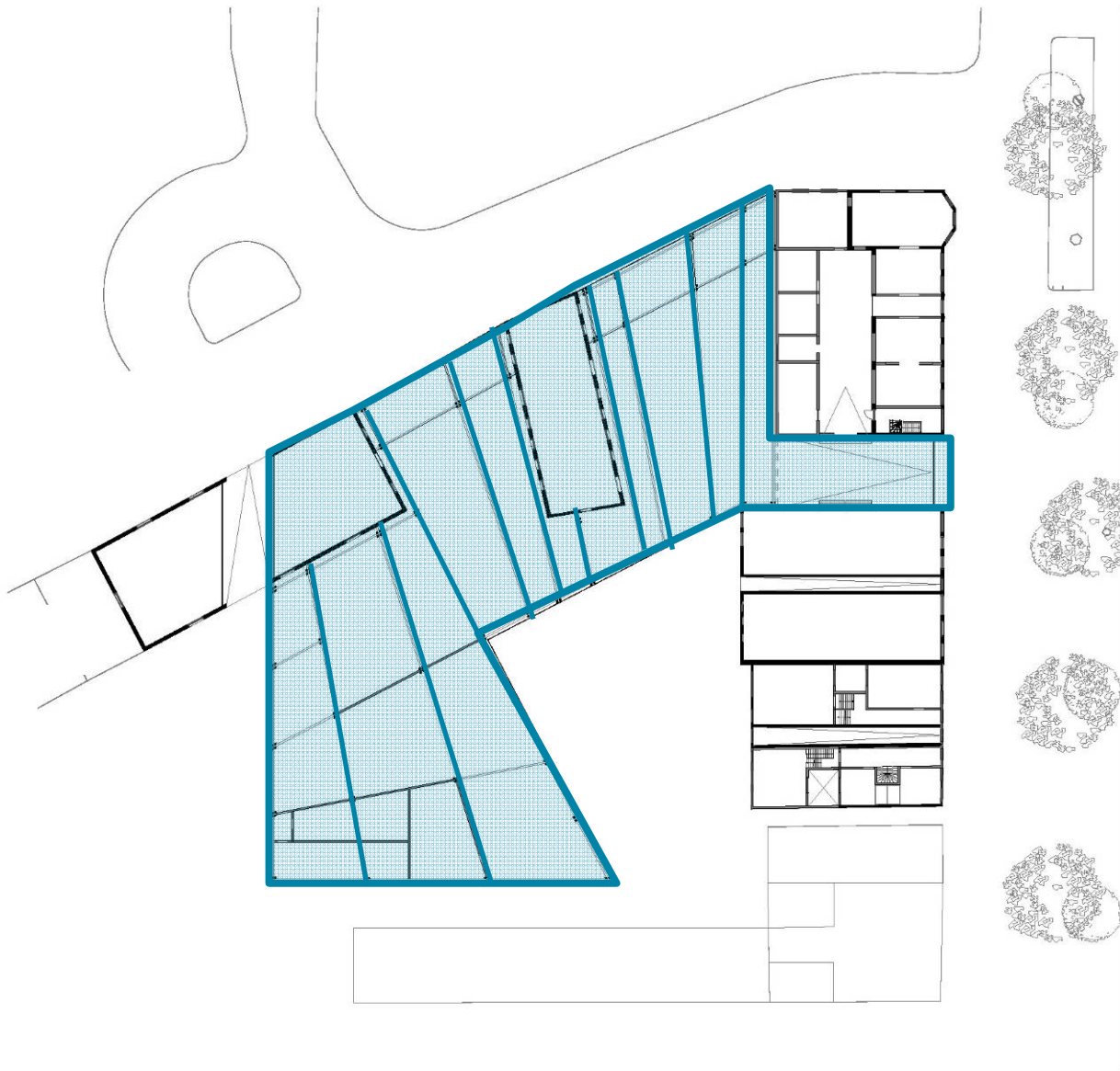

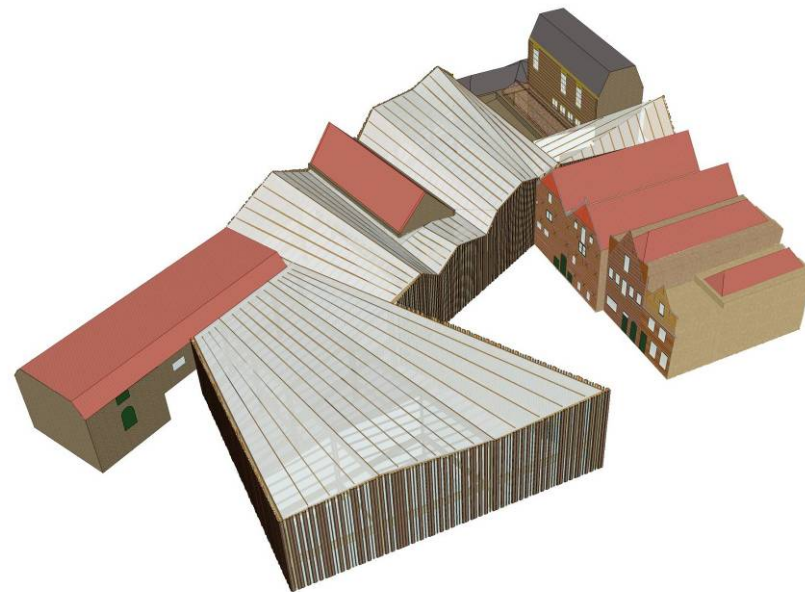

Vogelvlucht vanuit zuid-oosten en vanuit zuid-westen

Gemeente Vlaardingen
sectie B
nummer 8048

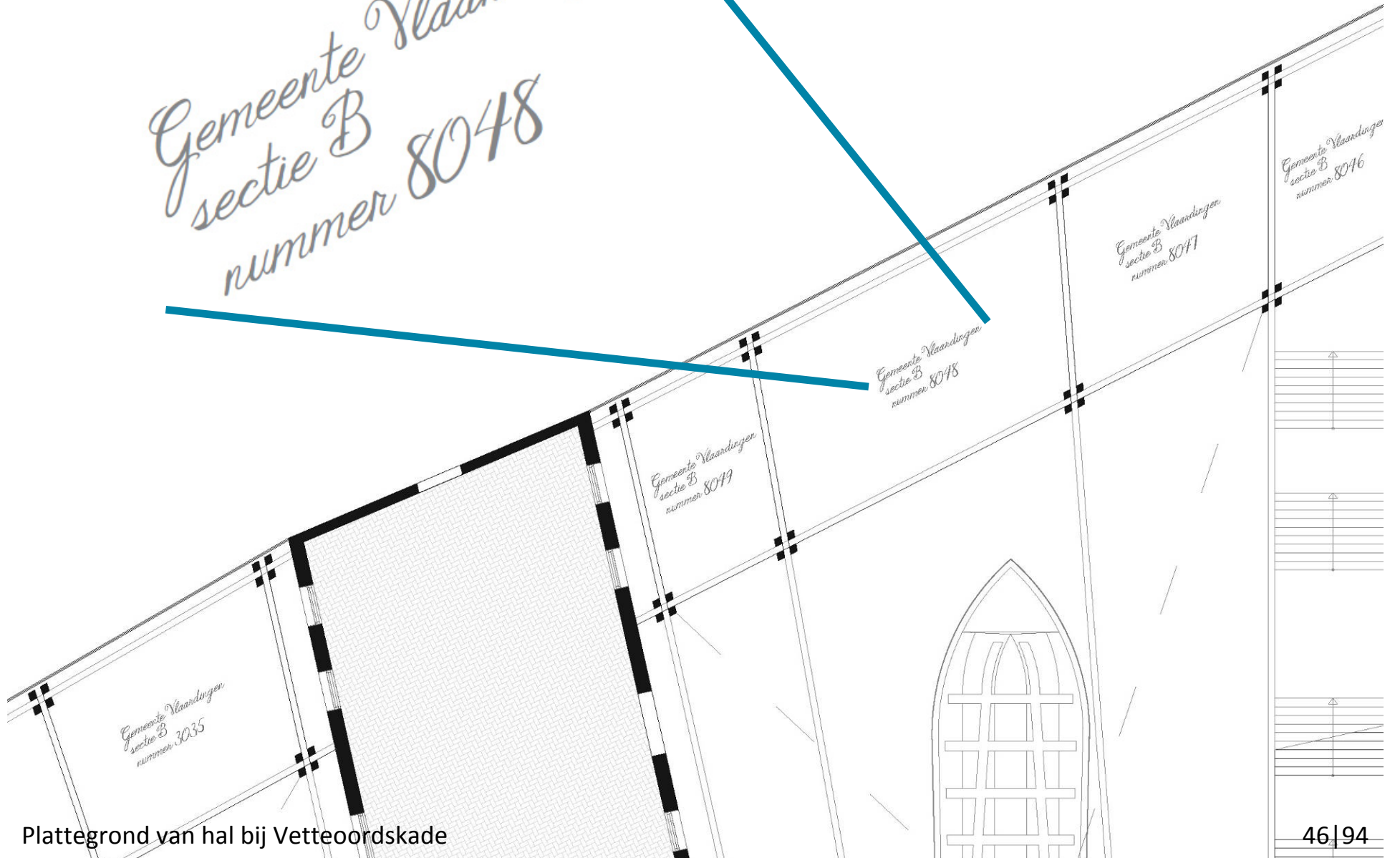

Plattegrond van hal bij Vetteoordskade

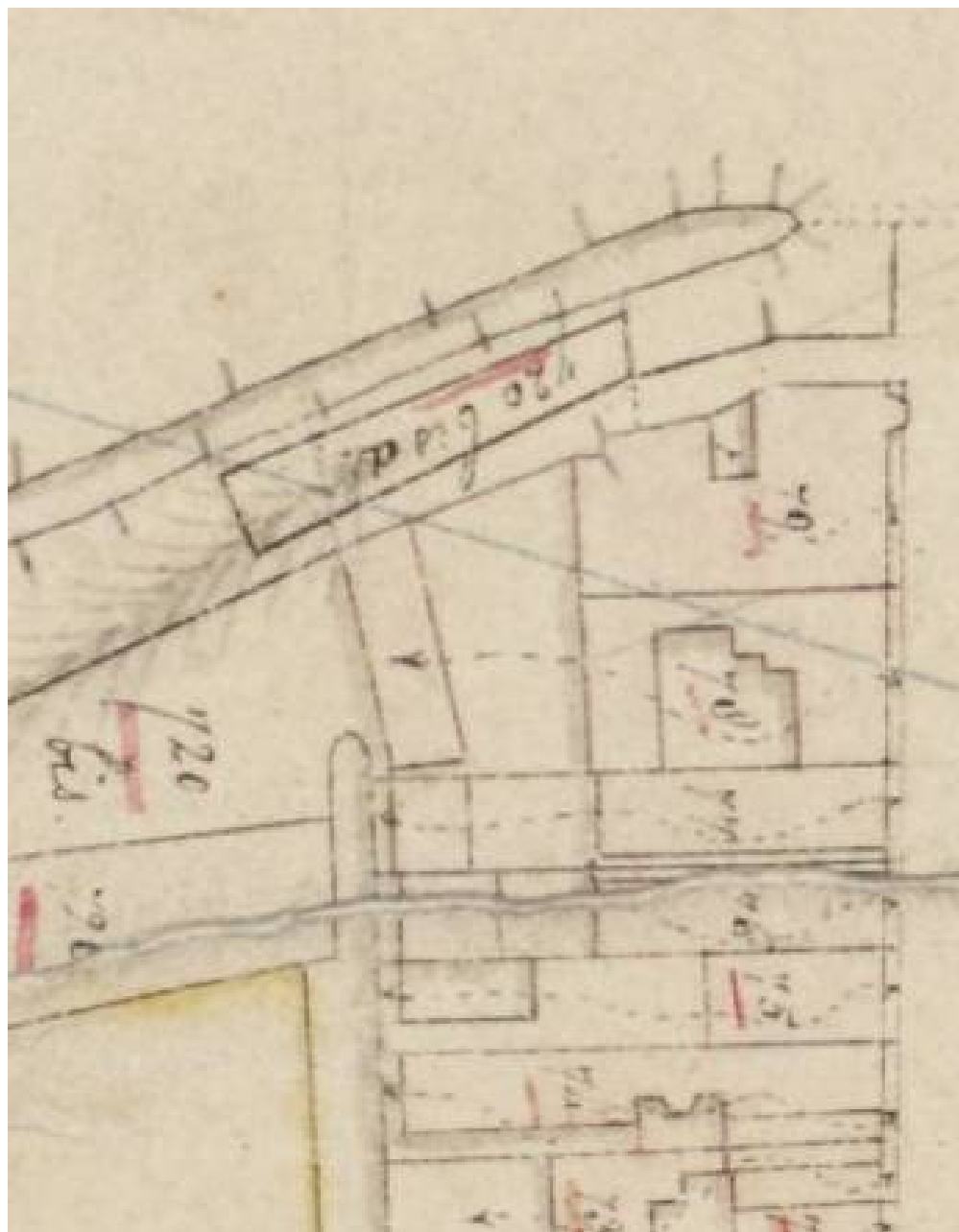

				EIGENAREN EN VRUCHTGEBRUIKERS		
Polder, gebiedt plaatselijke benaming.	N ^o . der perceelen op het kadastrale plan.	Verwijzing naar het Algemeen Register der Hypotheken.		NAMM.	VOORNAMEN.	EERDEPEN
		Deel.	Nummer.			
	1			Maardingen	de Stad	
	14					
	17			Delfland.	het Oorlogsmagazijn	
	18			Maardingen	de Stad	
	19			"	"	
	20			"	"	
Maar. dingen	21			Harmonie.	Societeit	
414	22			Linden van den Heuvel	Andrieus Ludenrijn van Burgen	
	23			"	"	
415	24			Brobbel de	Jacob	
412	25			Sluitgeest wed.	Silletje	
411	26			Wijlen van der Bent Gijzen	Simon van der	Preed
410	27			Jansen.	Anthony	Tapp
409	28			Spuisman wed. Lindert Kleinweg	Elisabeth	
408	29			Weijden.	Arij van der	Schij
407	30			voordhoek	wed. Arie	
406	31			Kop	Lusanna de	
405	32			Gelden	Petrus van	

Kadasterkaart, 1830, en kadastrale administratie, rond 1850



Interieur houten pakhuis



Tonnenmakers, rond 1900

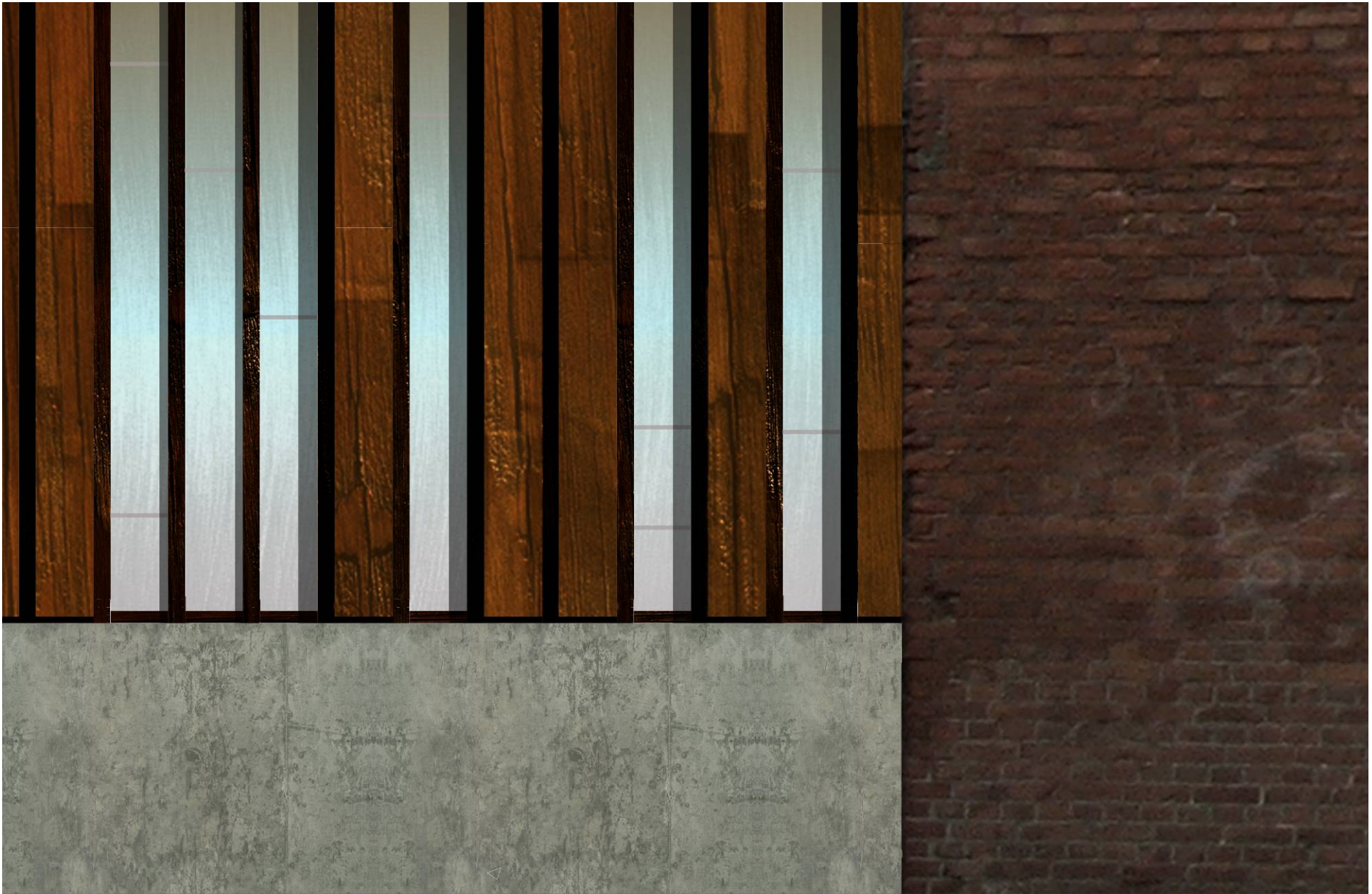



Fragment gevel binnenplein

Steeg Gebouw doorbreking
Kolommen Samengesteld (masten)
"Lamellen" Om en om, toeval
Doorgang Ervaring constructie
Dak Schaduw, energie
Trap Beleving ruimte
Blinde nis Abstracte "folly"
Bouwsporen Zichtbare geschiedenis
Behang Leven op stand

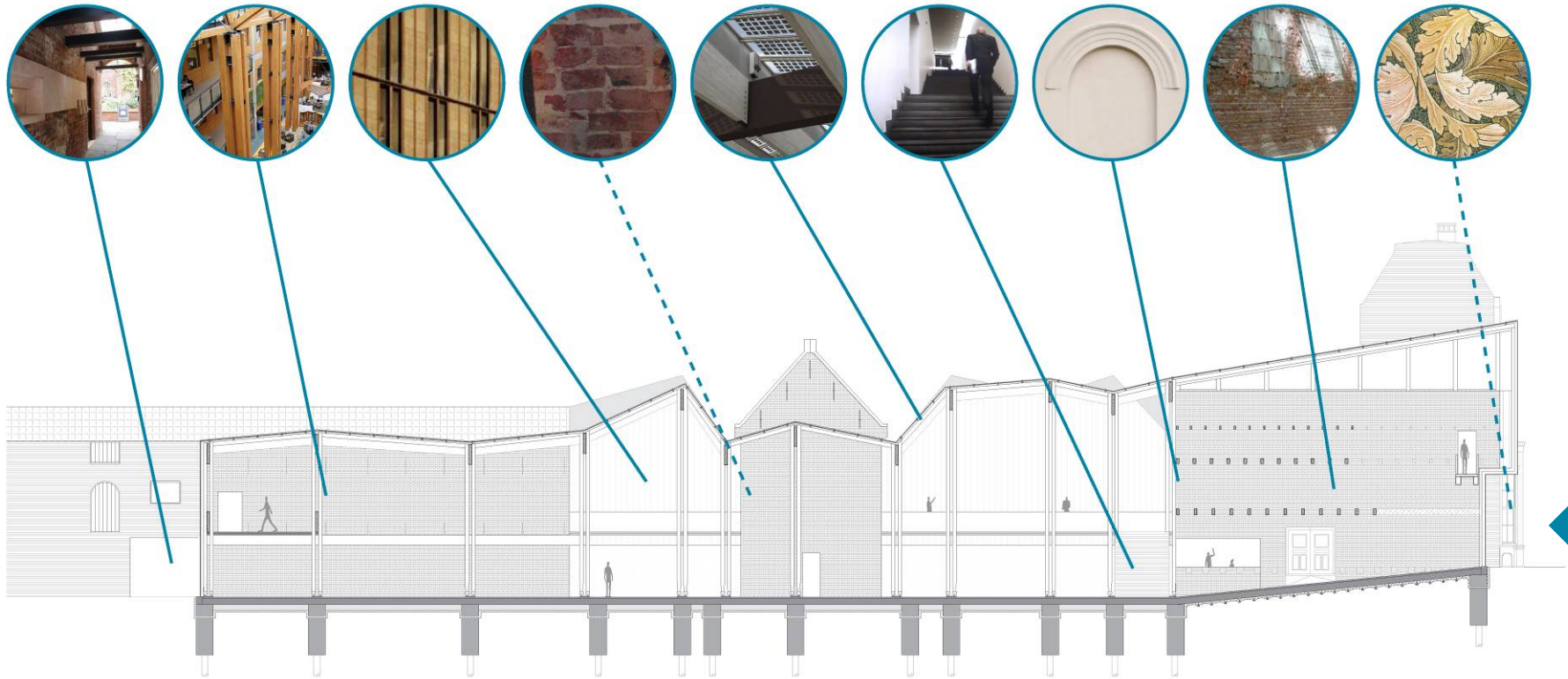

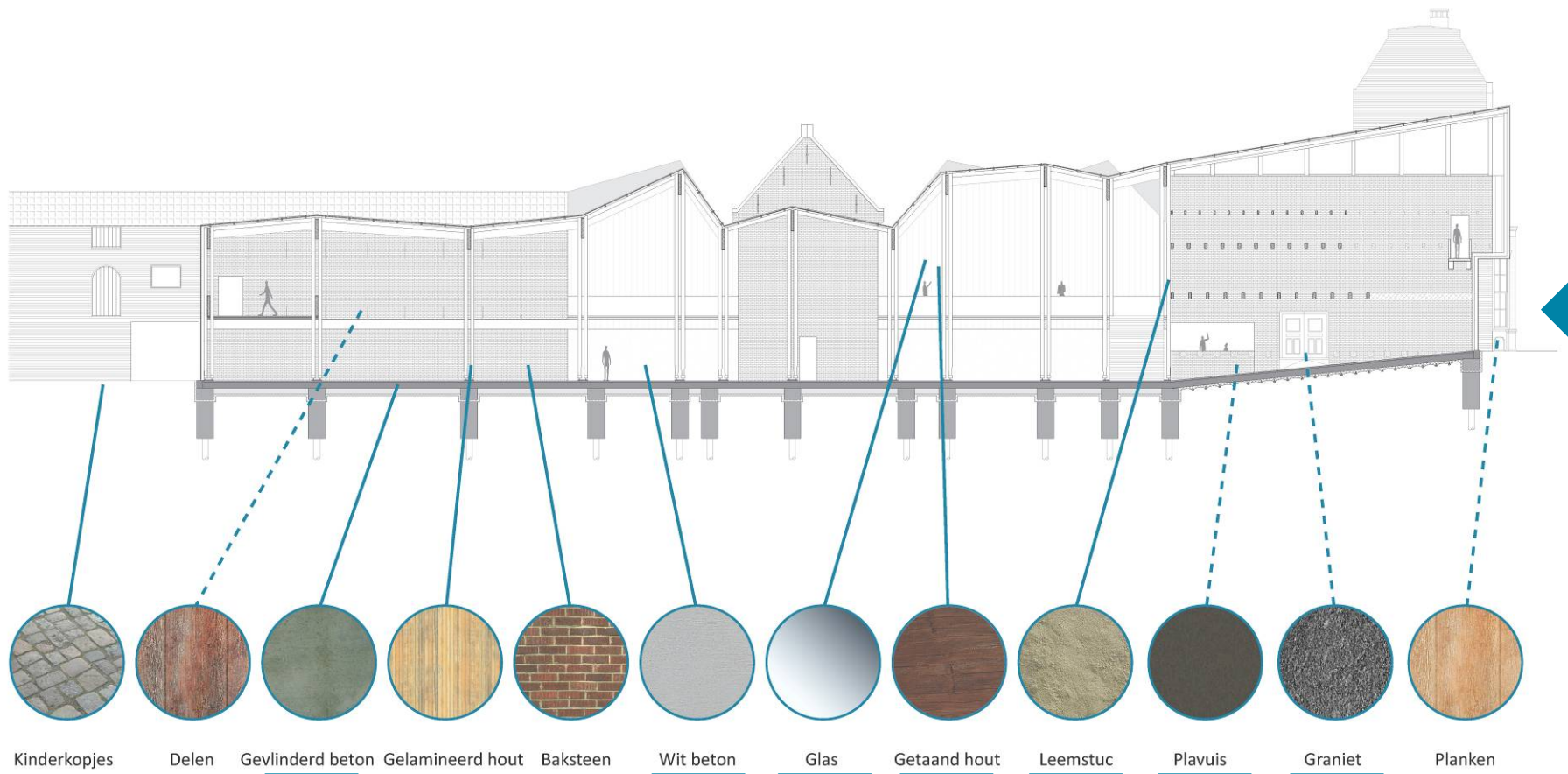



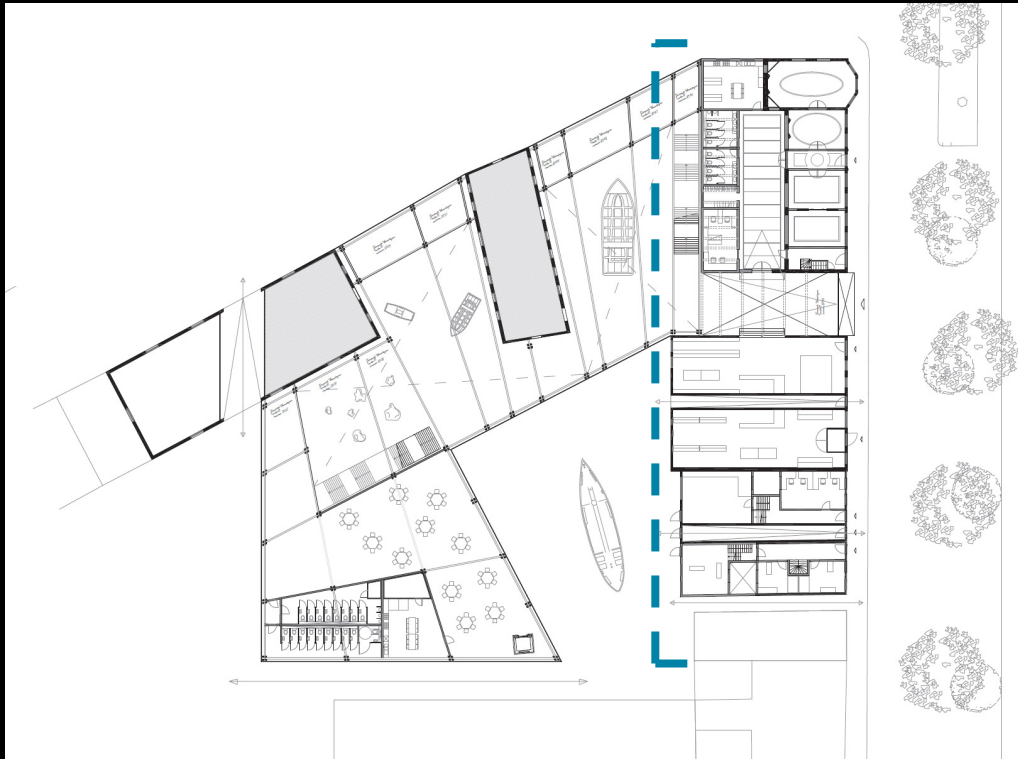



Doorsnede over hal

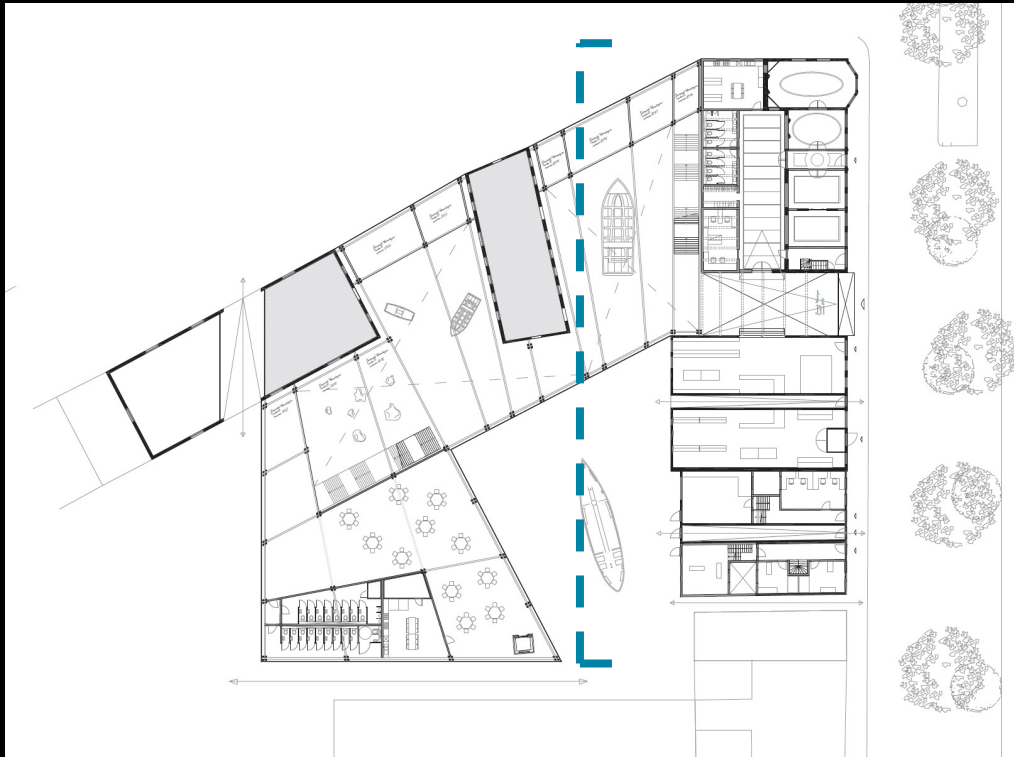

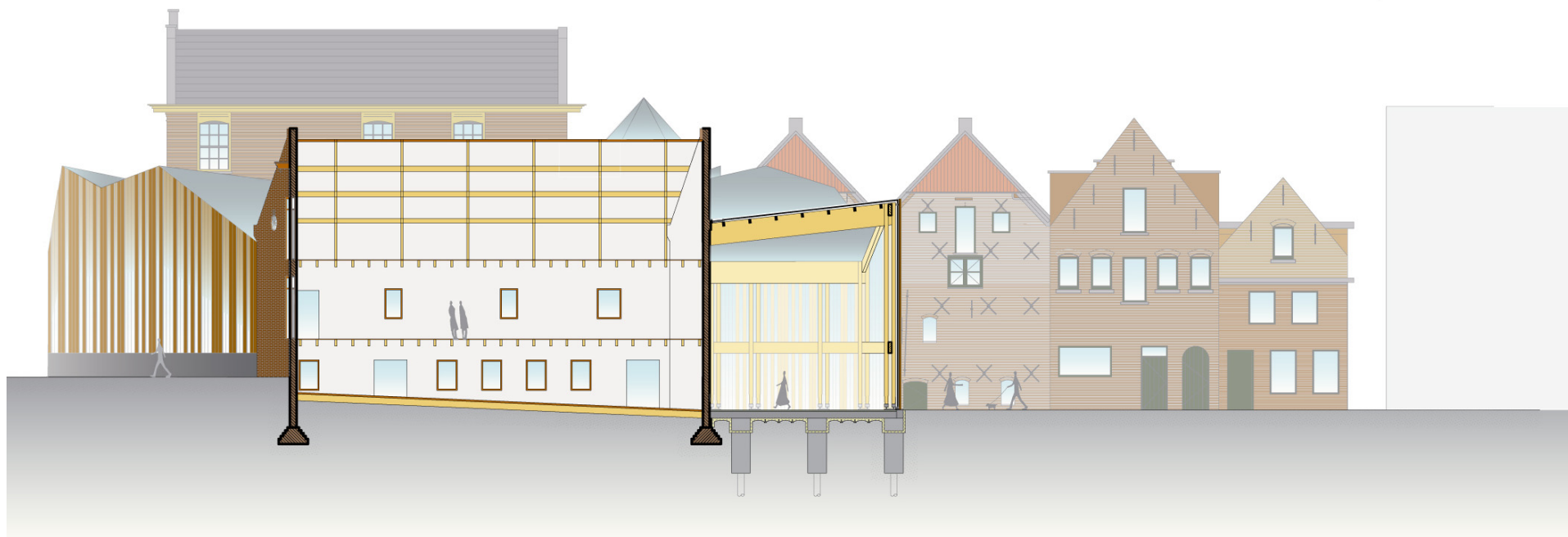

Doorsnede over pakhuis

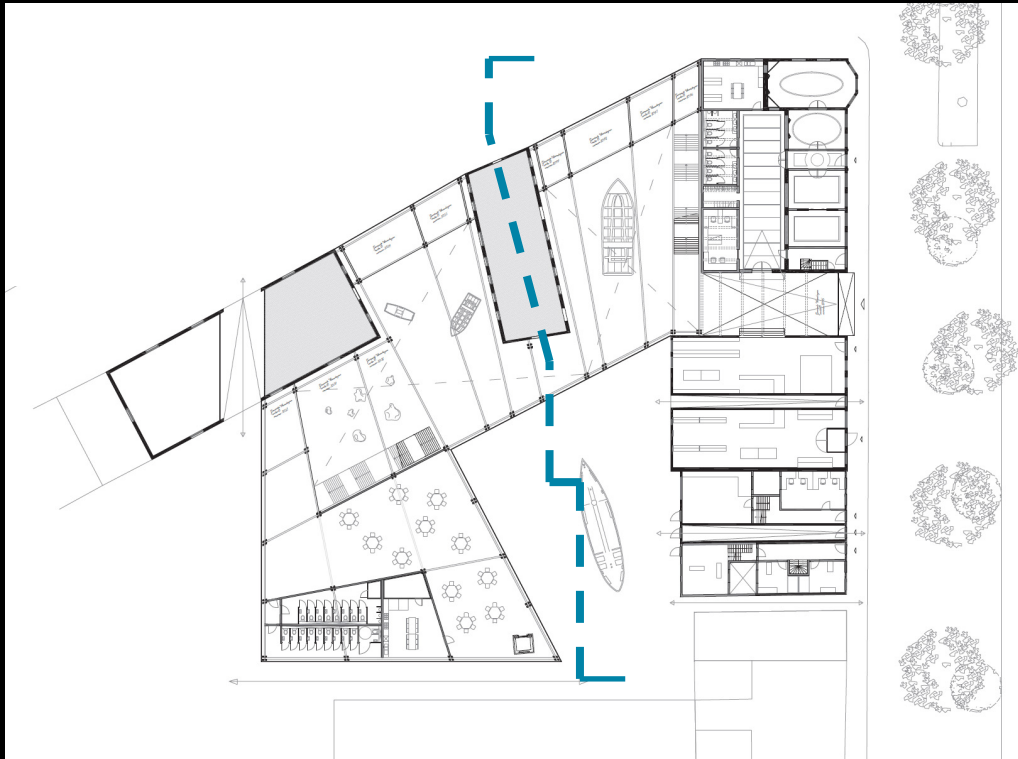



Doorsnede over hal

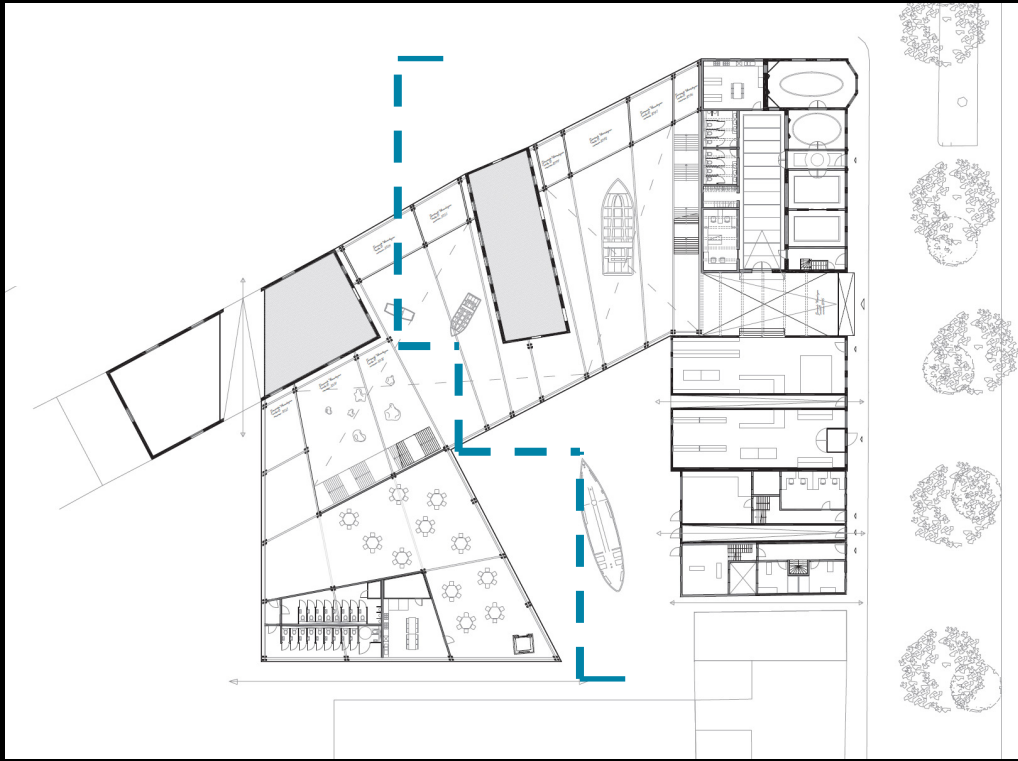



Doorsnede over pakhuis en hal

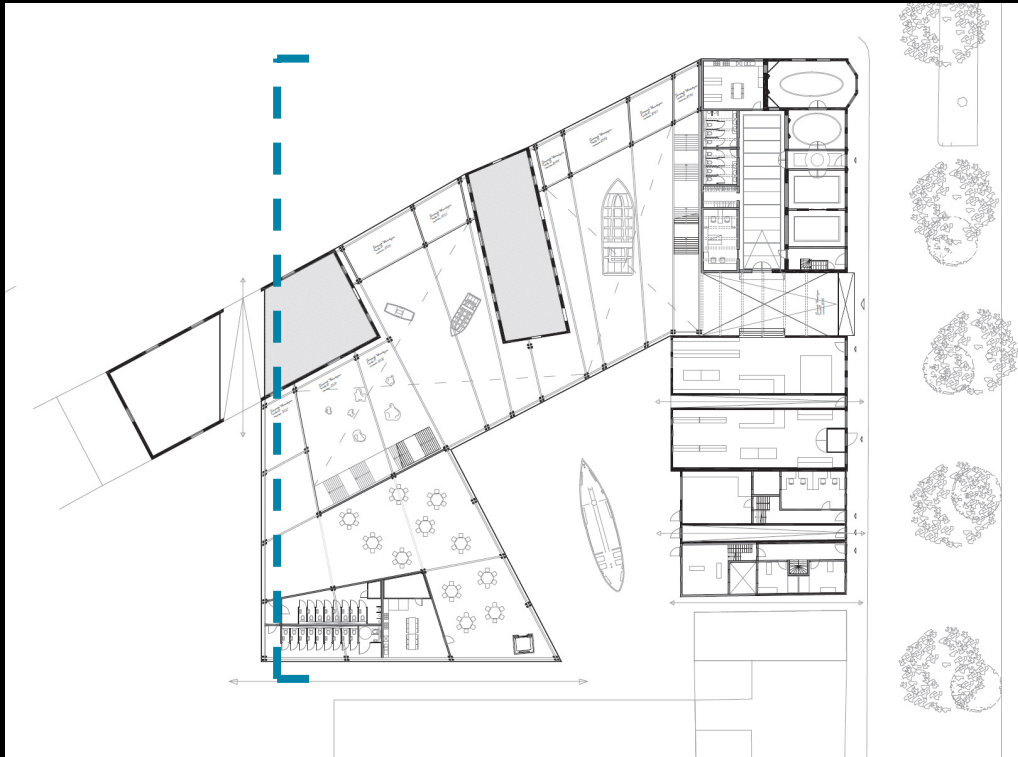

-  Ingang
-  Entree
-  Informatie
-  Stijlkamer
-  Keuken
-  WC
-  Garderobe
-  Trap
-  Winkel
-  VVV|ANWB
-  Kantoor
-  Museum
-  Werkplaats
-  Schepenhal
-  Archeologie
-  Stads geschiedenis
-  Café
-  Workshopruimte
-  Lift
-  Bibliotheek
-  Restauratieruimte
-  Depot

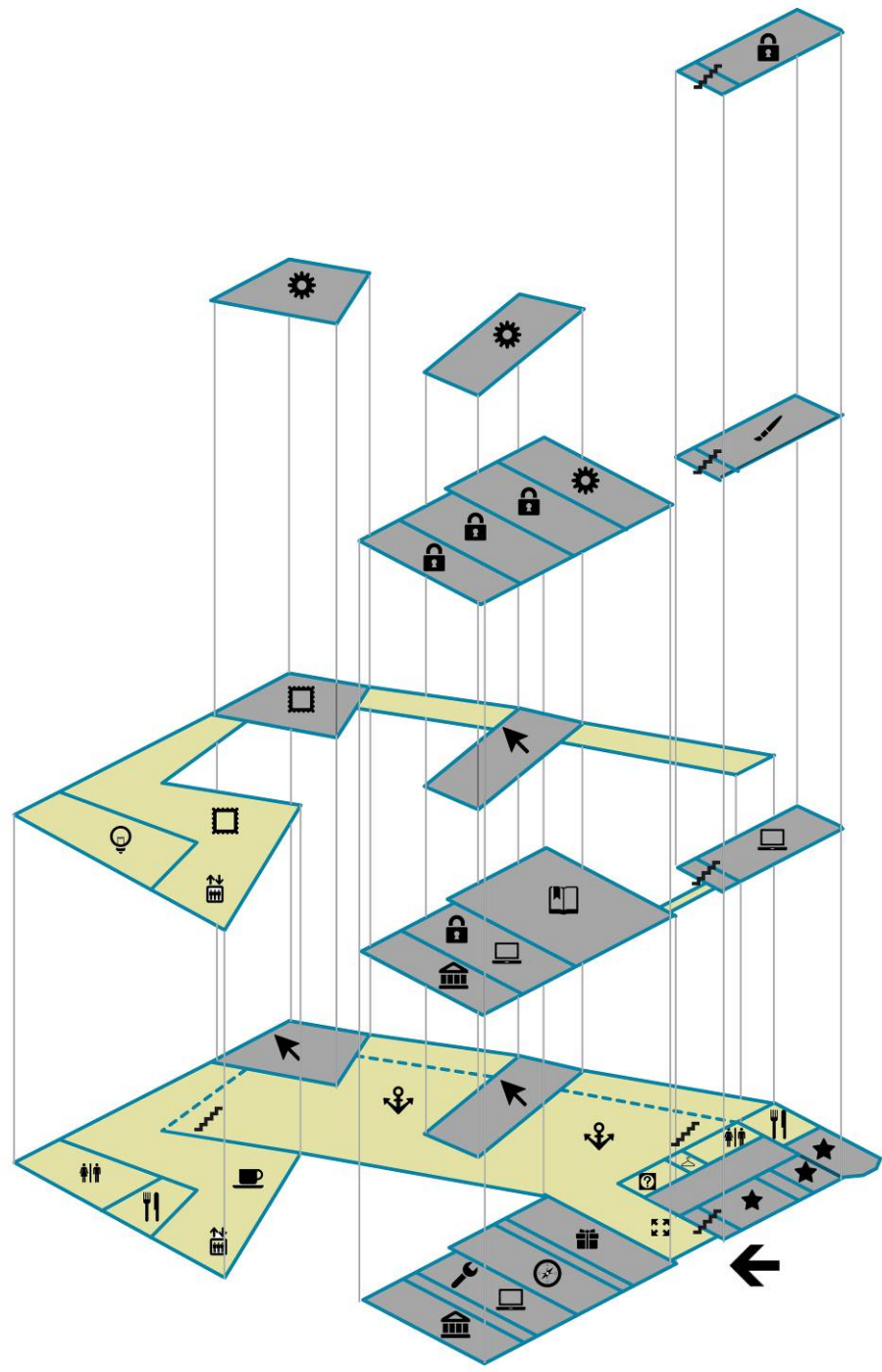

- I: museaal
- II: verblijfsruimte
- IIa: koele verblijfsruimte
- III: minimaal geklimatiseerd
- IV: buiten

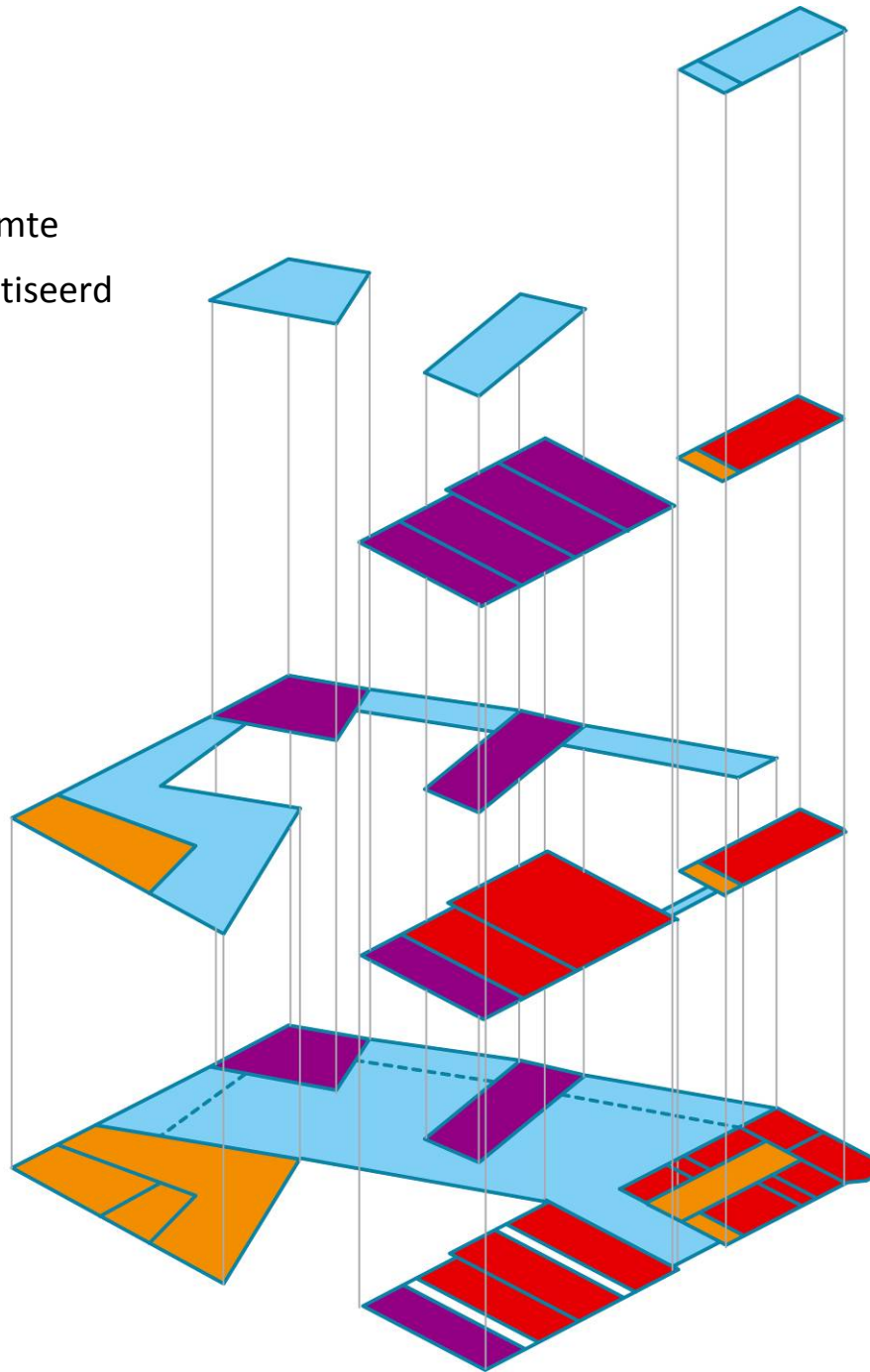

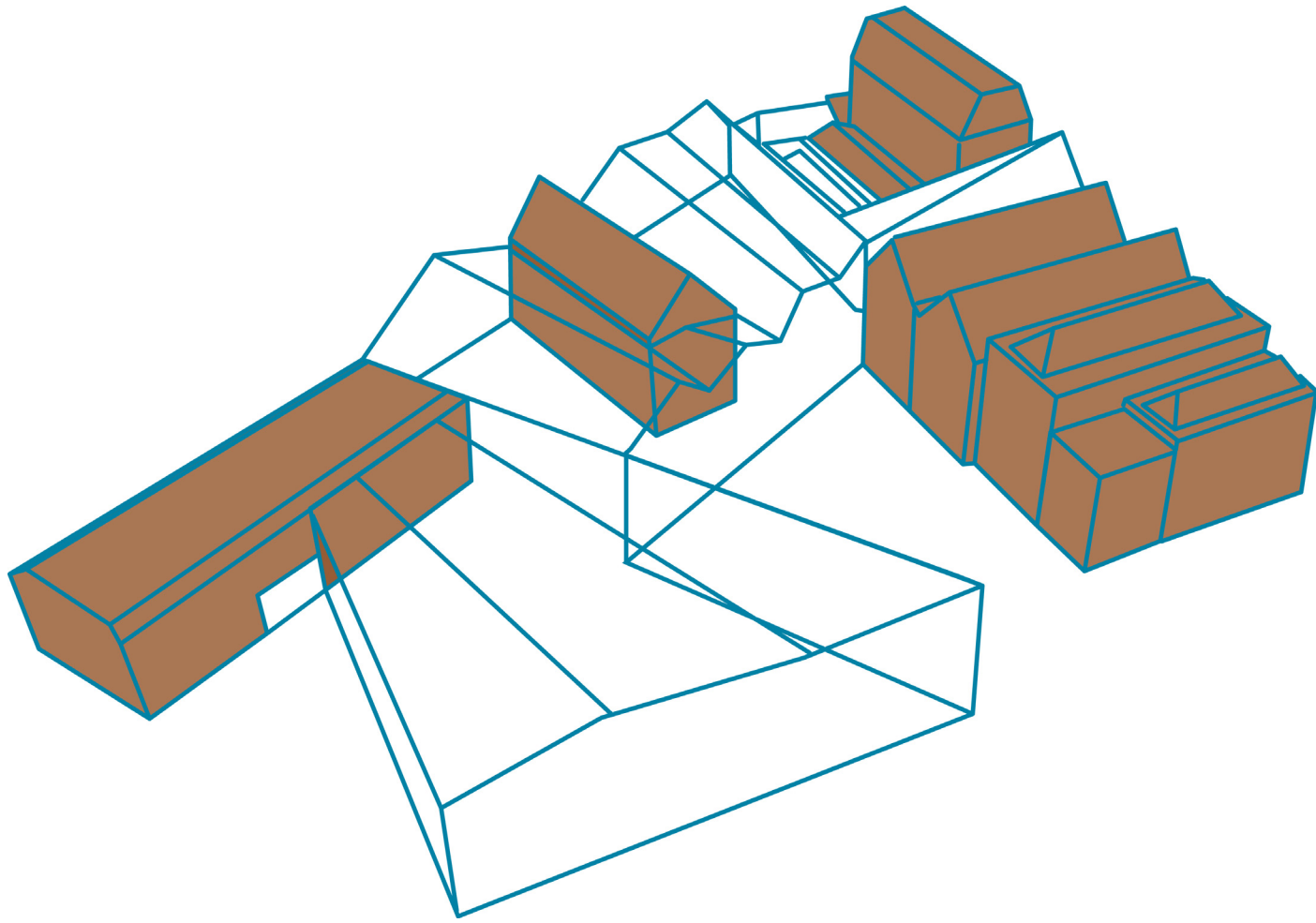

Hergebruik van panden

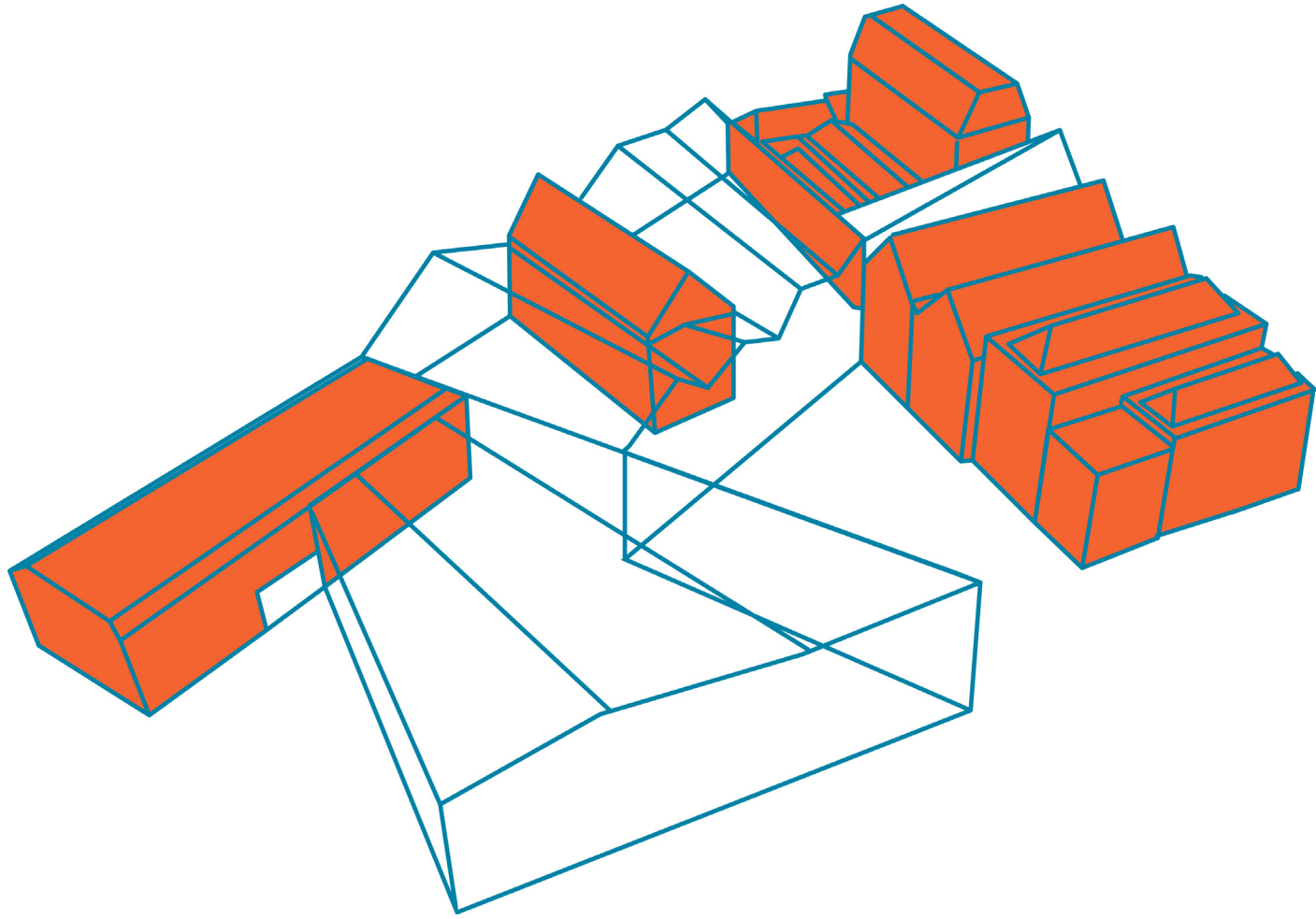
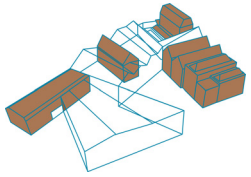

Geïsoleerd en geklimatiseerd

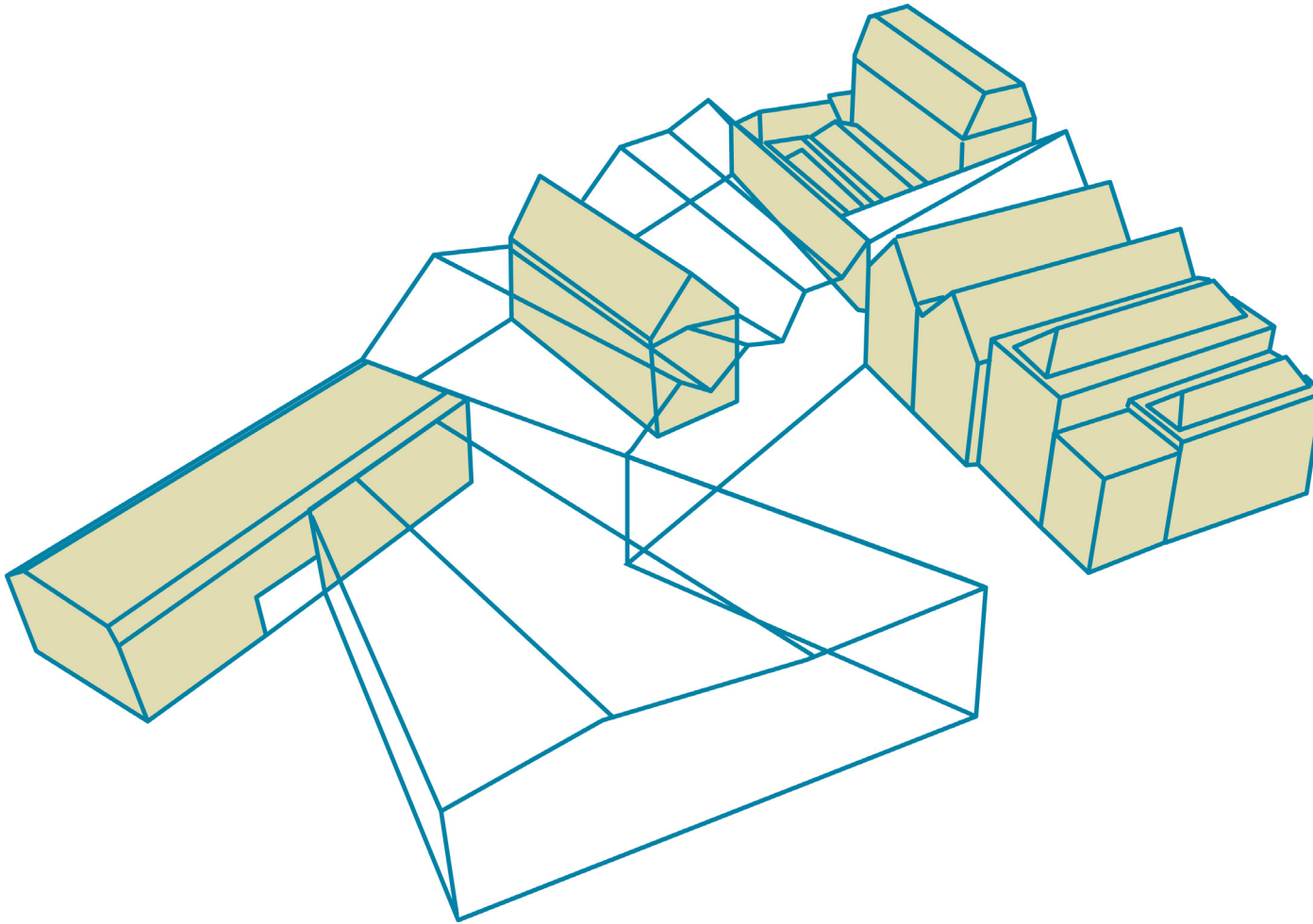
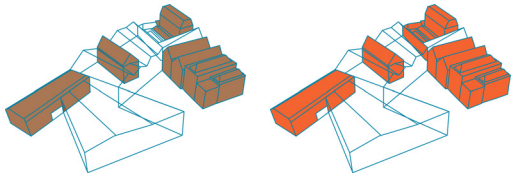

Leemstuc voor vochtregulatie

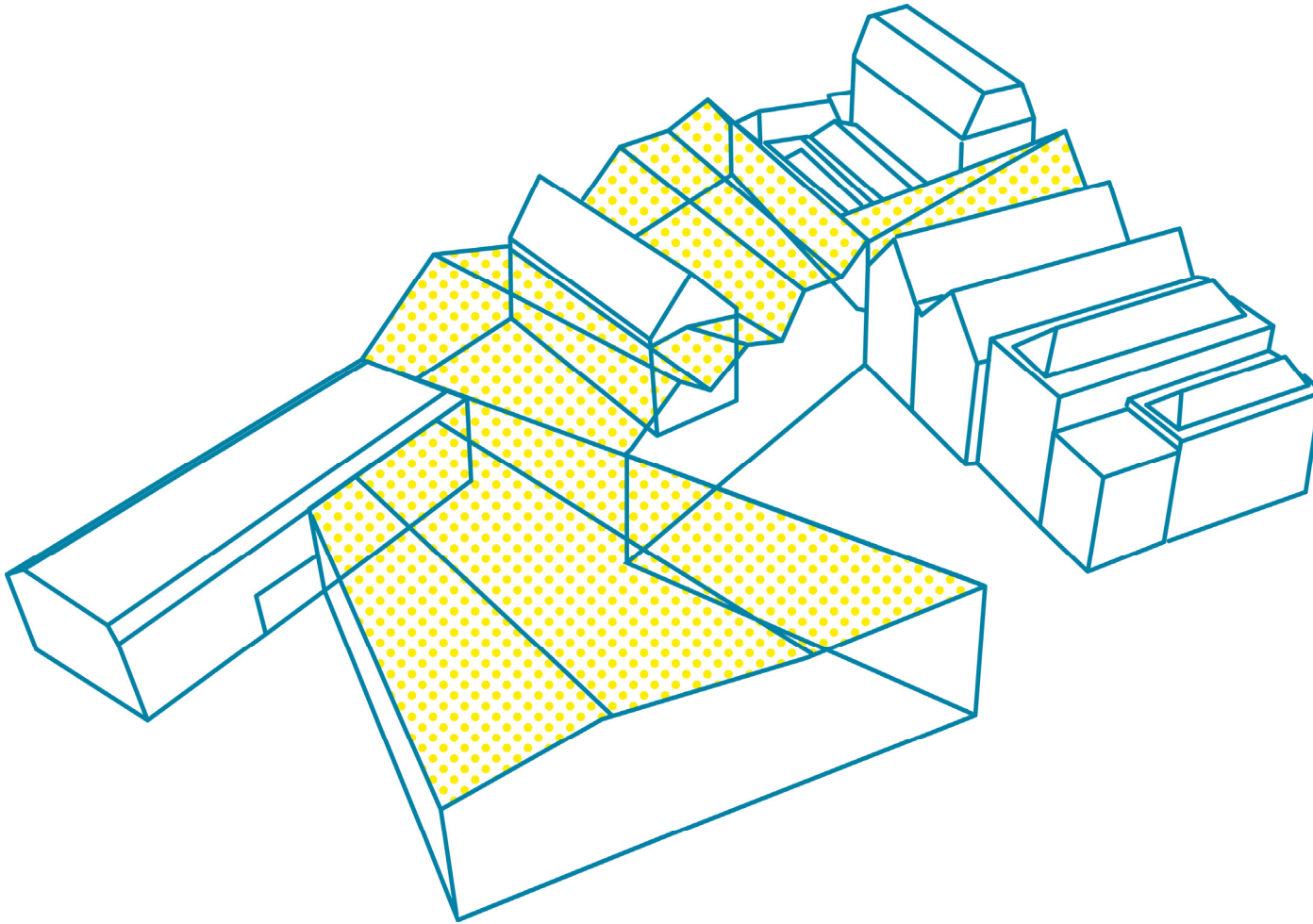
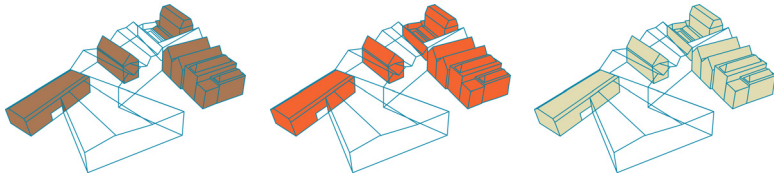

PV-cellen voor elektriciteit

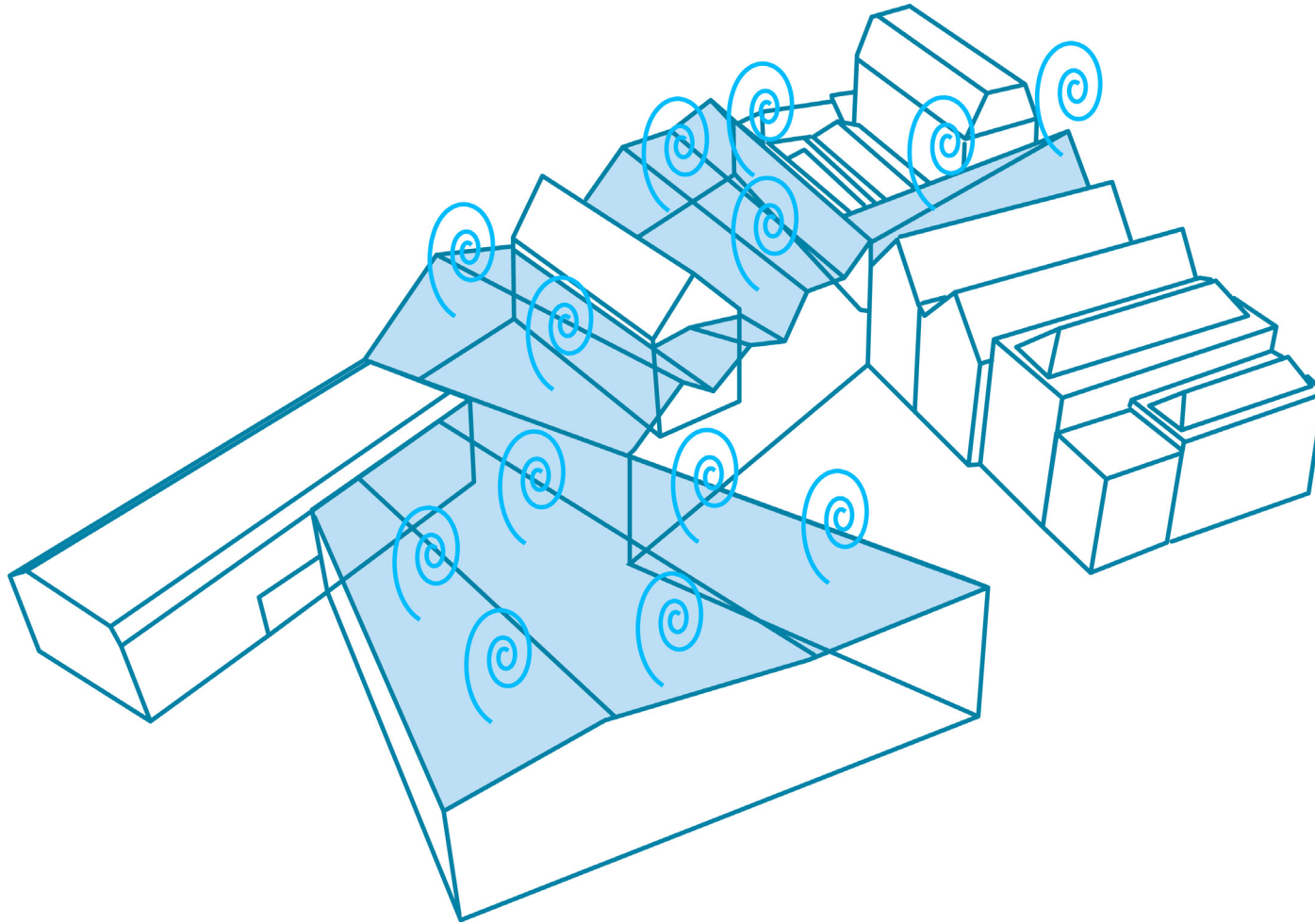
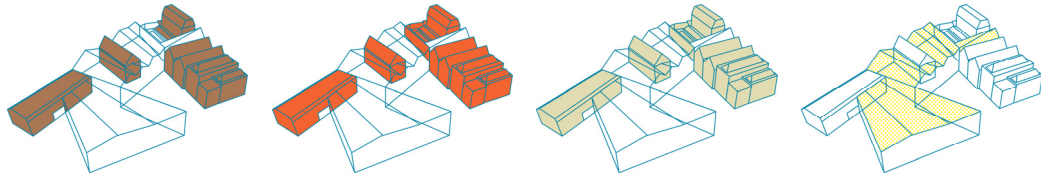

Dakramen voor natuurlijke ventilatie

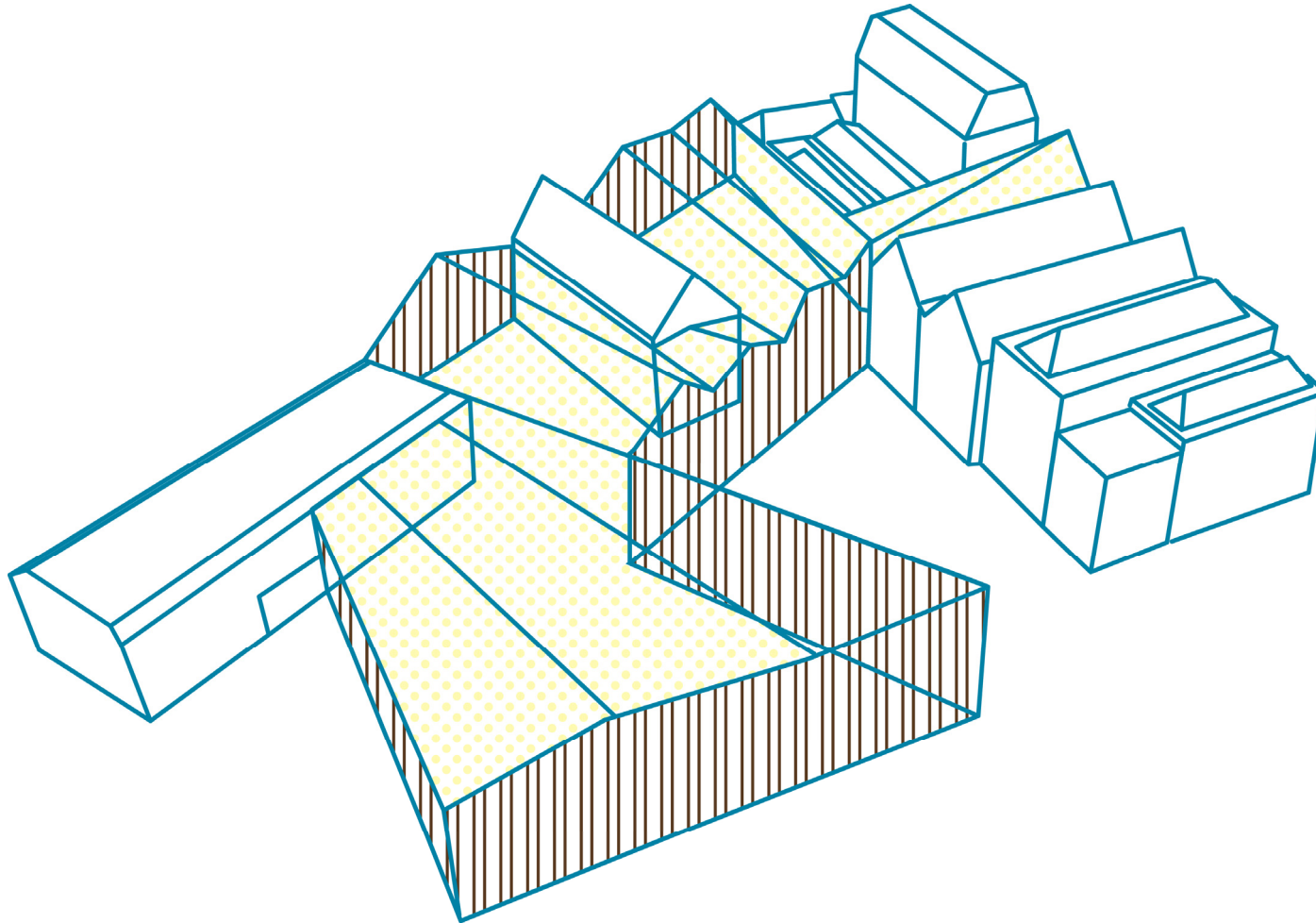
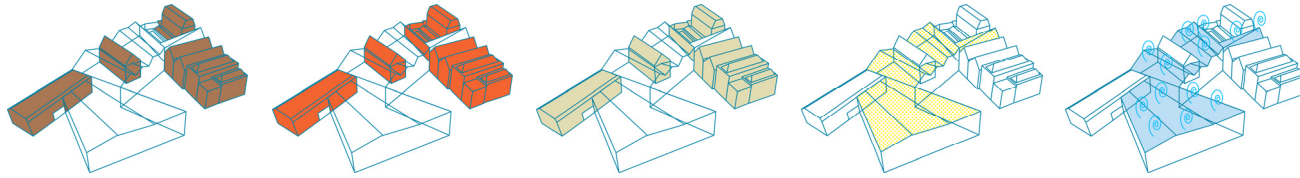

“Lamellen” (+ PV-cellen) voor schaduw

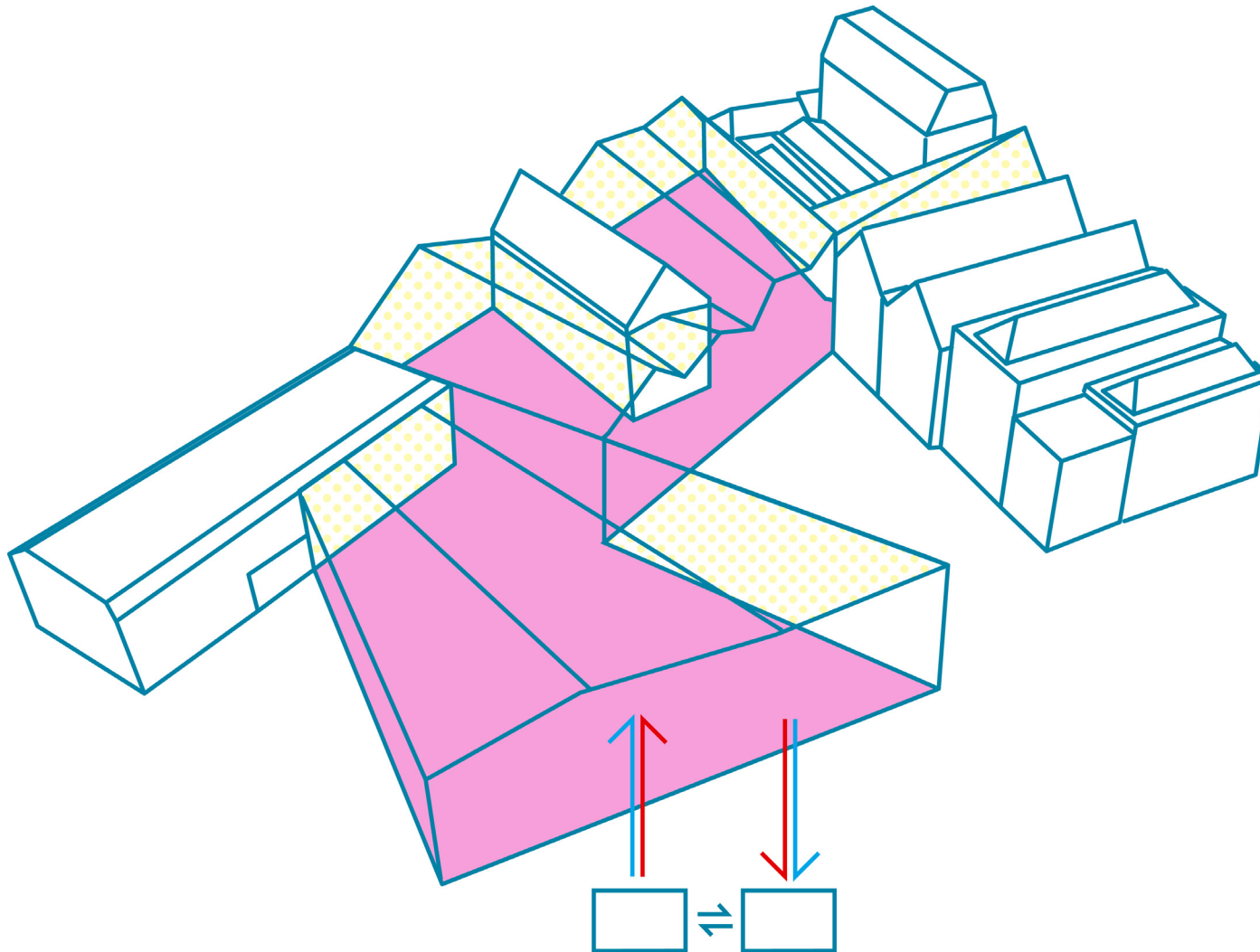
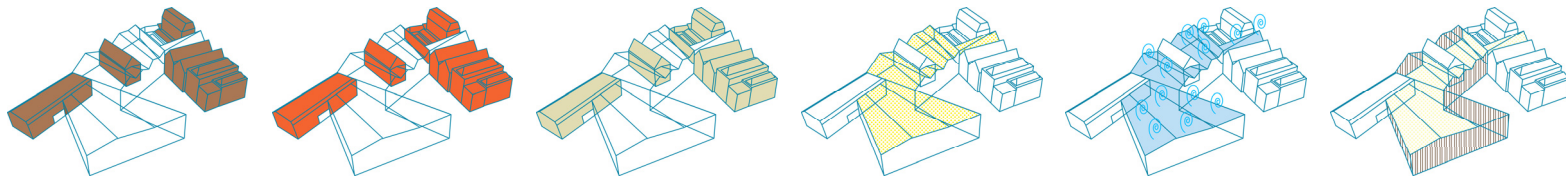

Vloerverwarming en WK-opslag

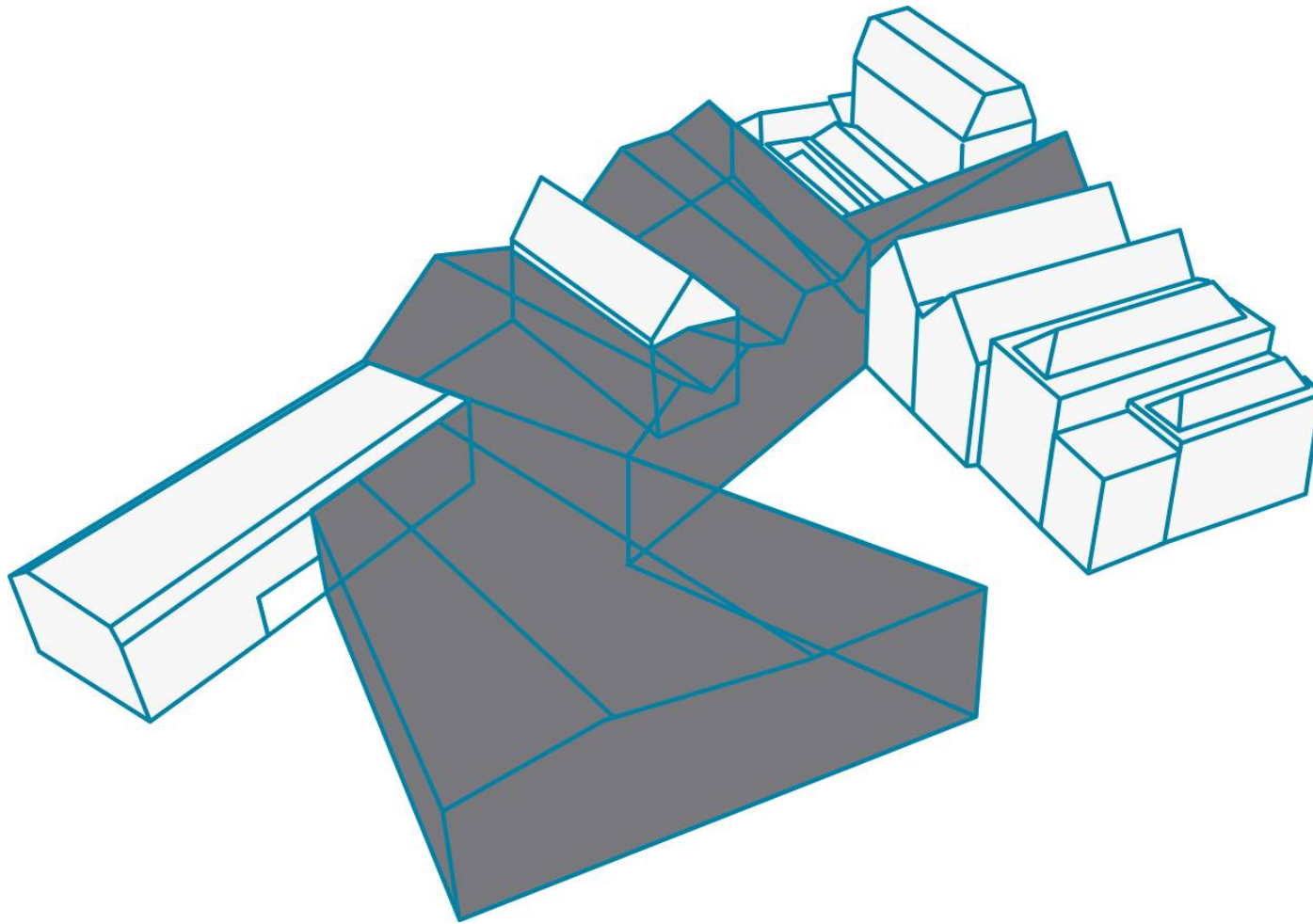
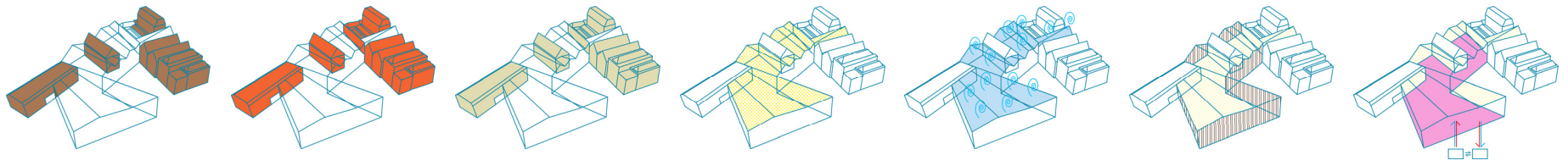

~~Hal met gebouwen~~

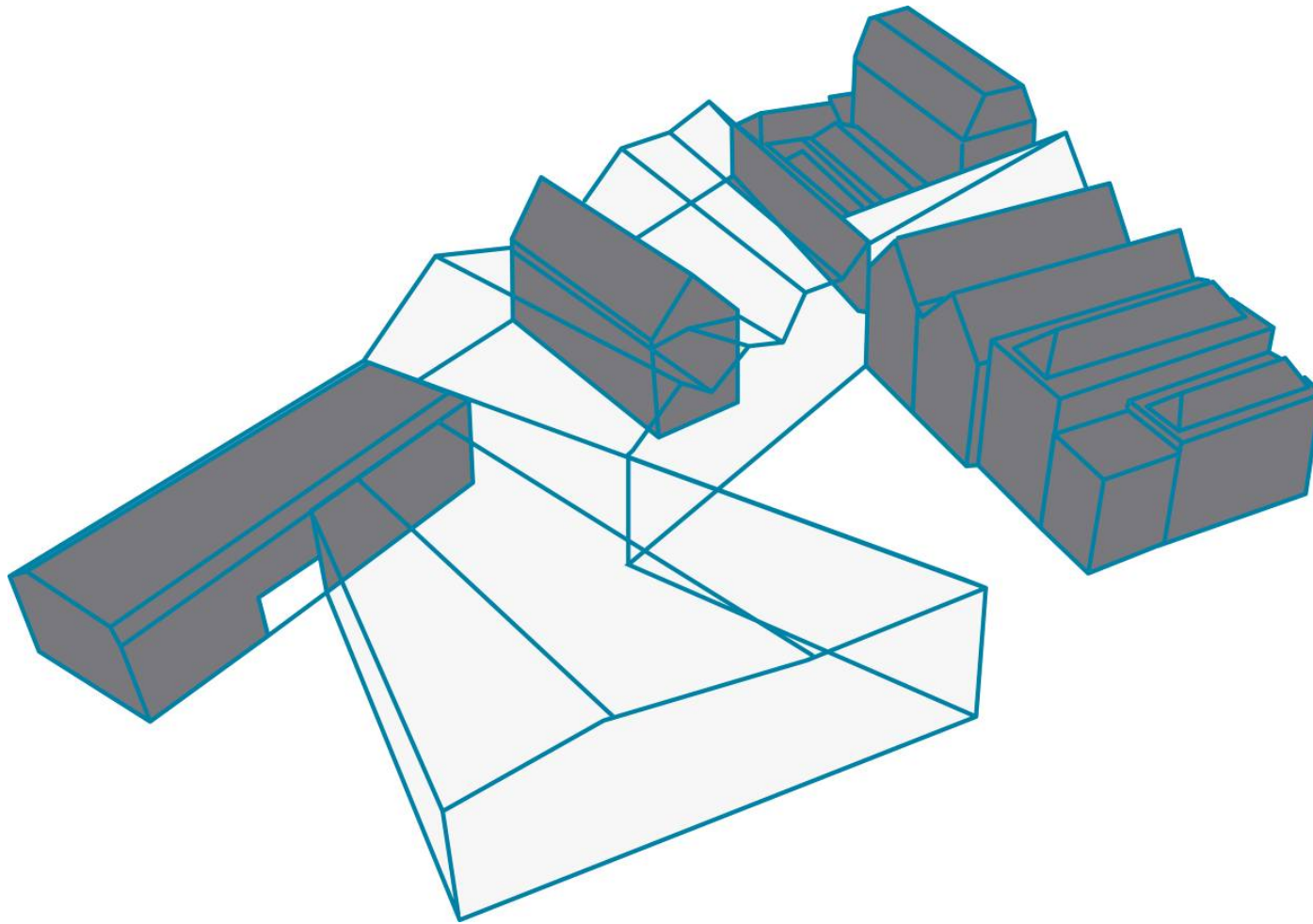
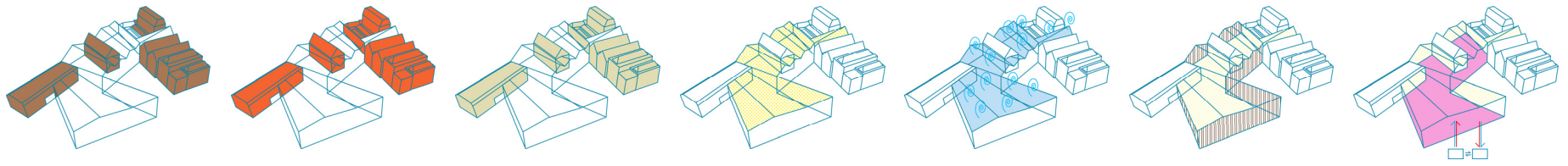

Gebouwen met hal

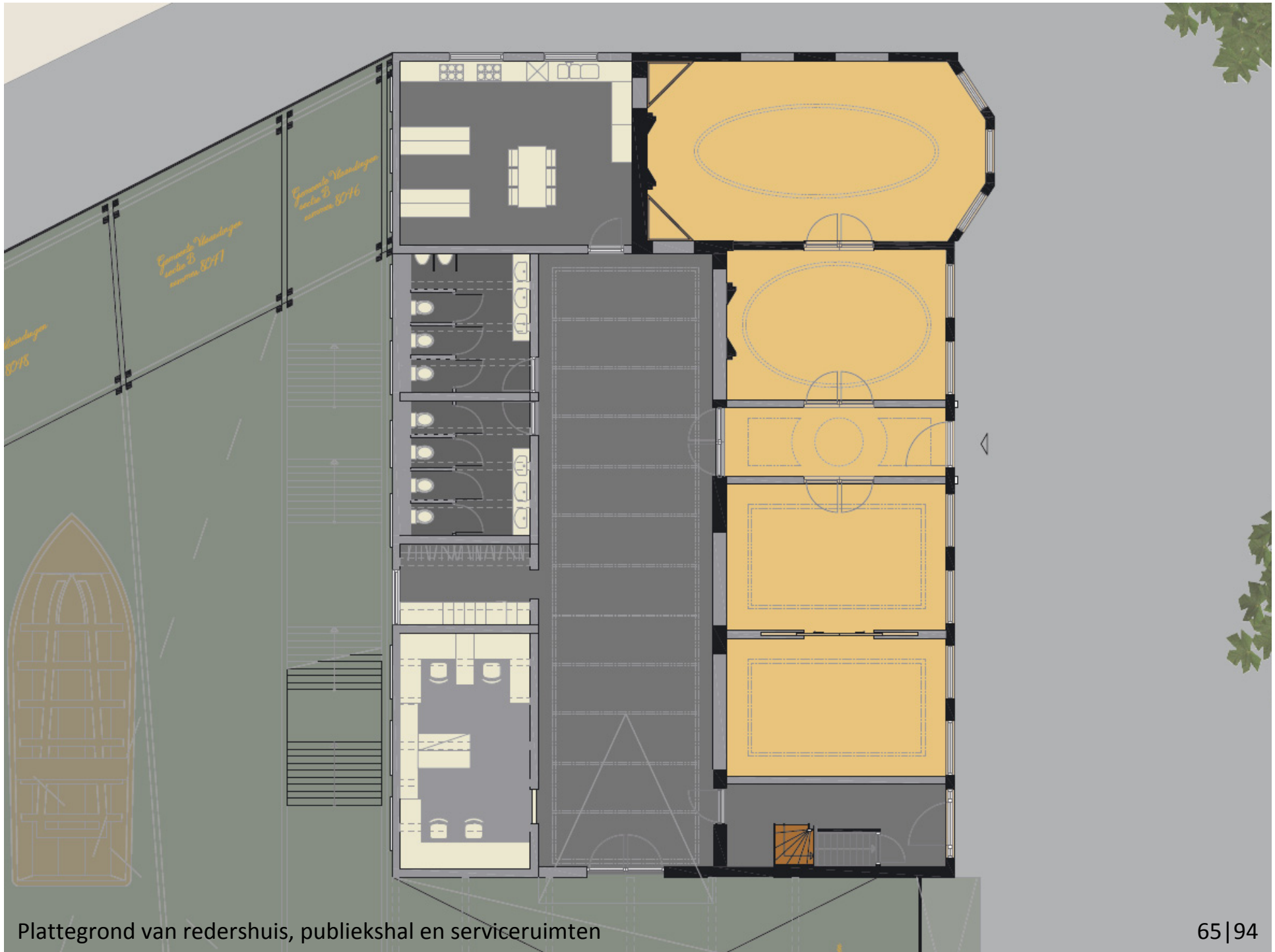

Plattegrond van redershuis, publiekshal en serviceruimten

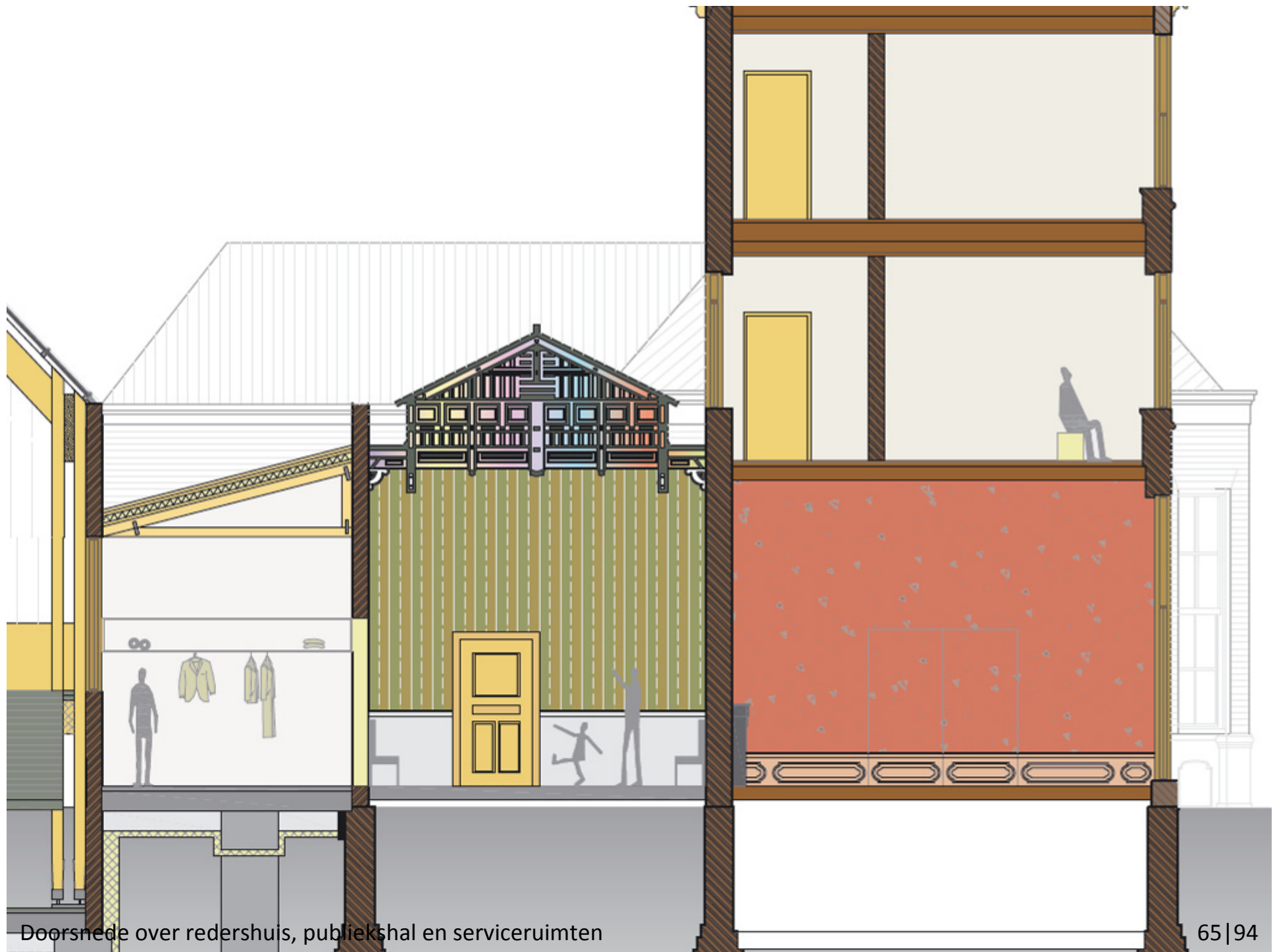

Doorsnede over redershuis, publiekshal en serviceruimten

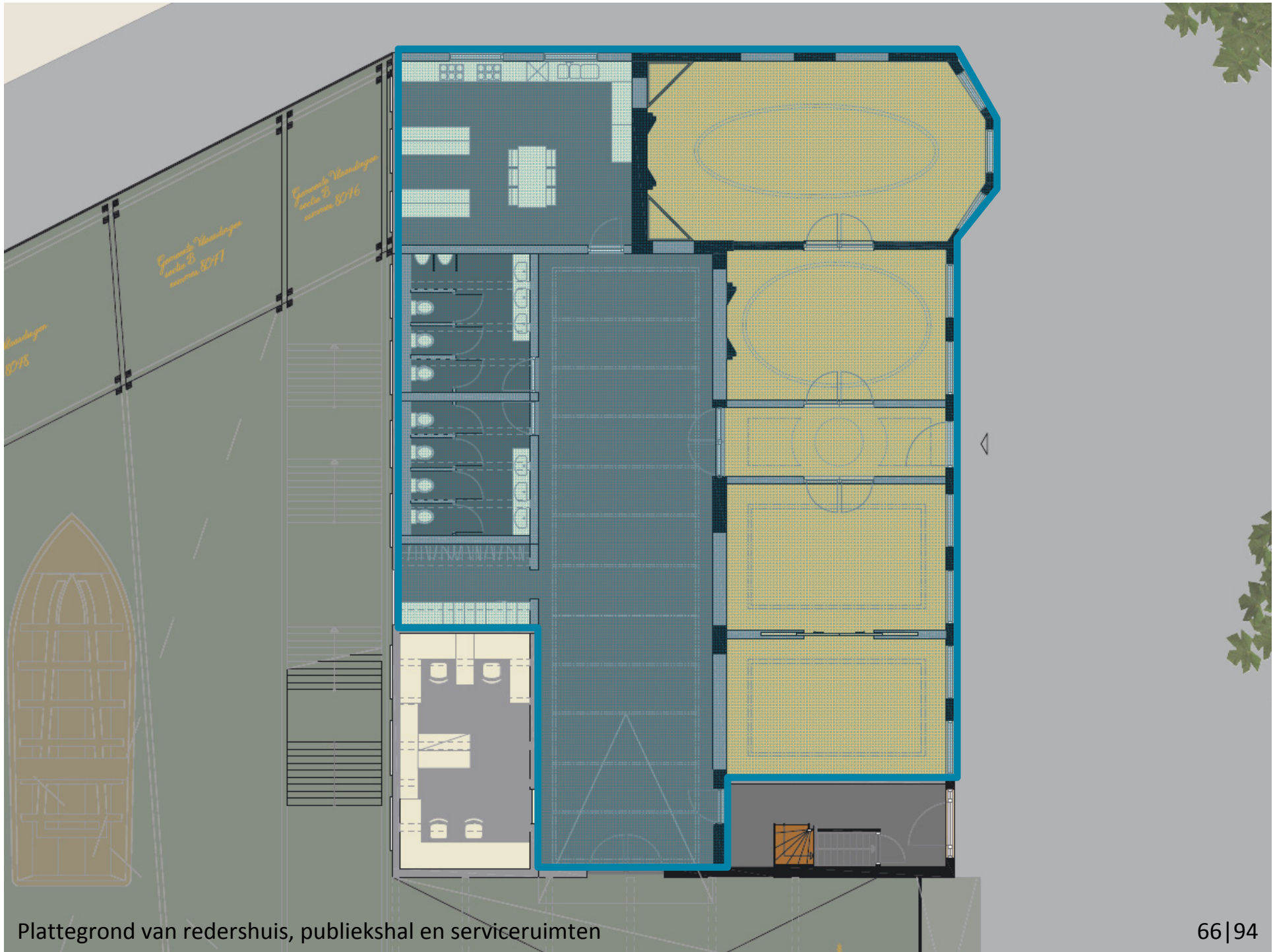

Plattegrond van redershuis, publiekshal en serviceruimten

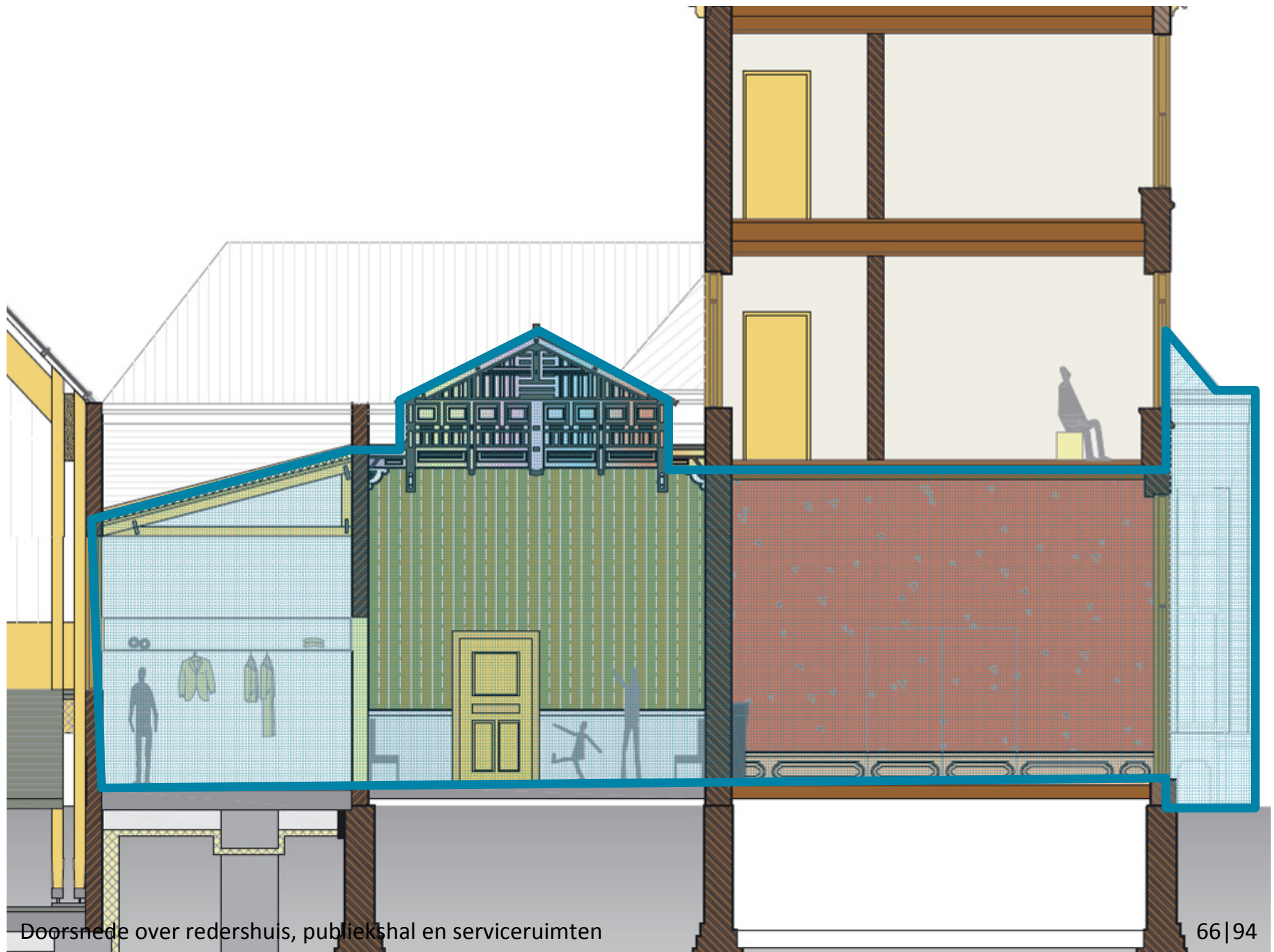

Doorsnede over redershuis, publiekshal en serviceruimten

- Restaureren
- Renoveren
- Reconstrueren
- Introduceren

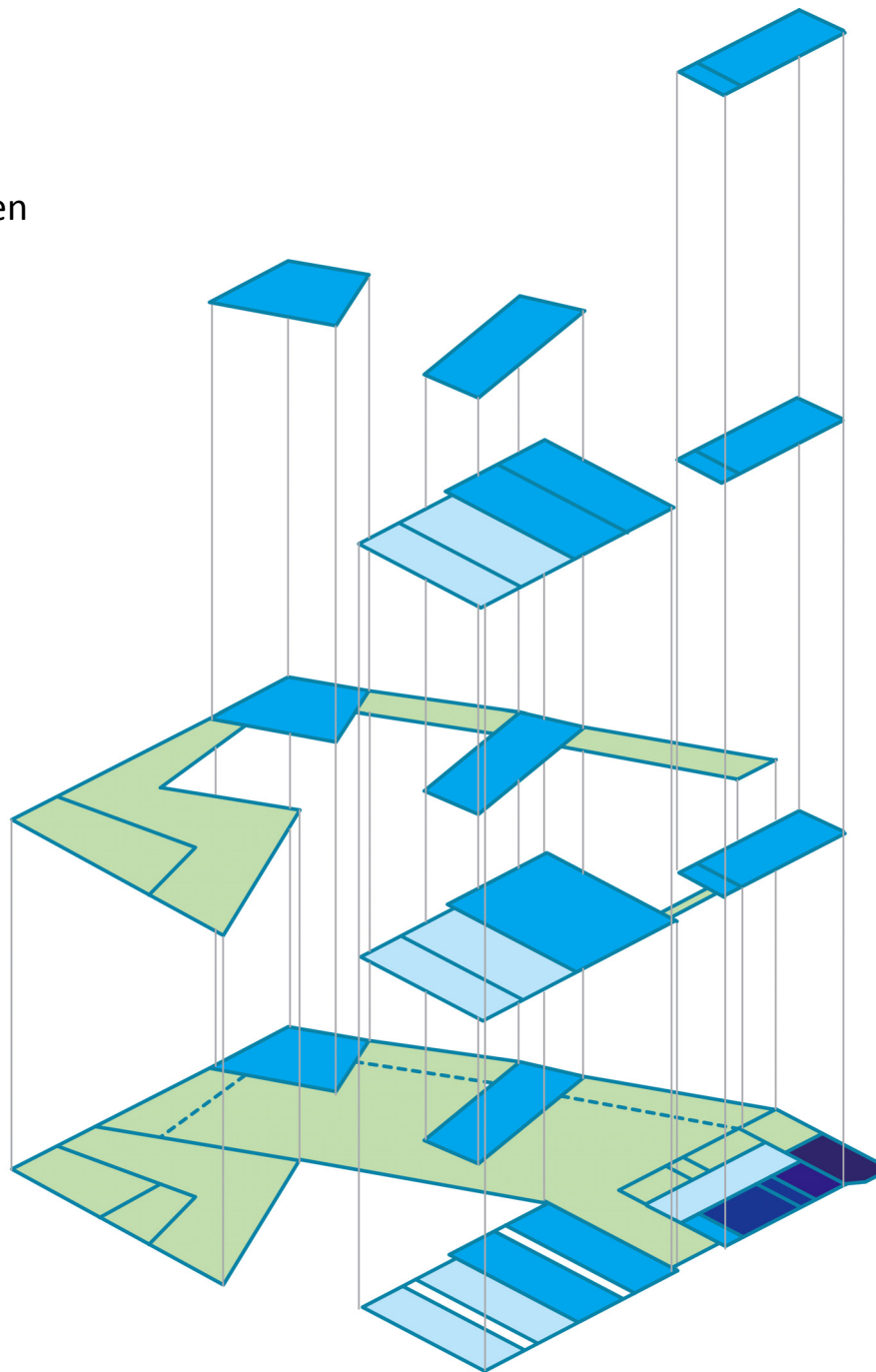

- Restaureren
- Renoveren
- Reconstrueren
- Introduceren

- 18^e eeuwse ruimte met 18^e eeuwse blik
- 18^e eeuwse ruimte met 20^e eeuwse blik
- 20^e eeuwse ruimte met 21^e eeuwse blik

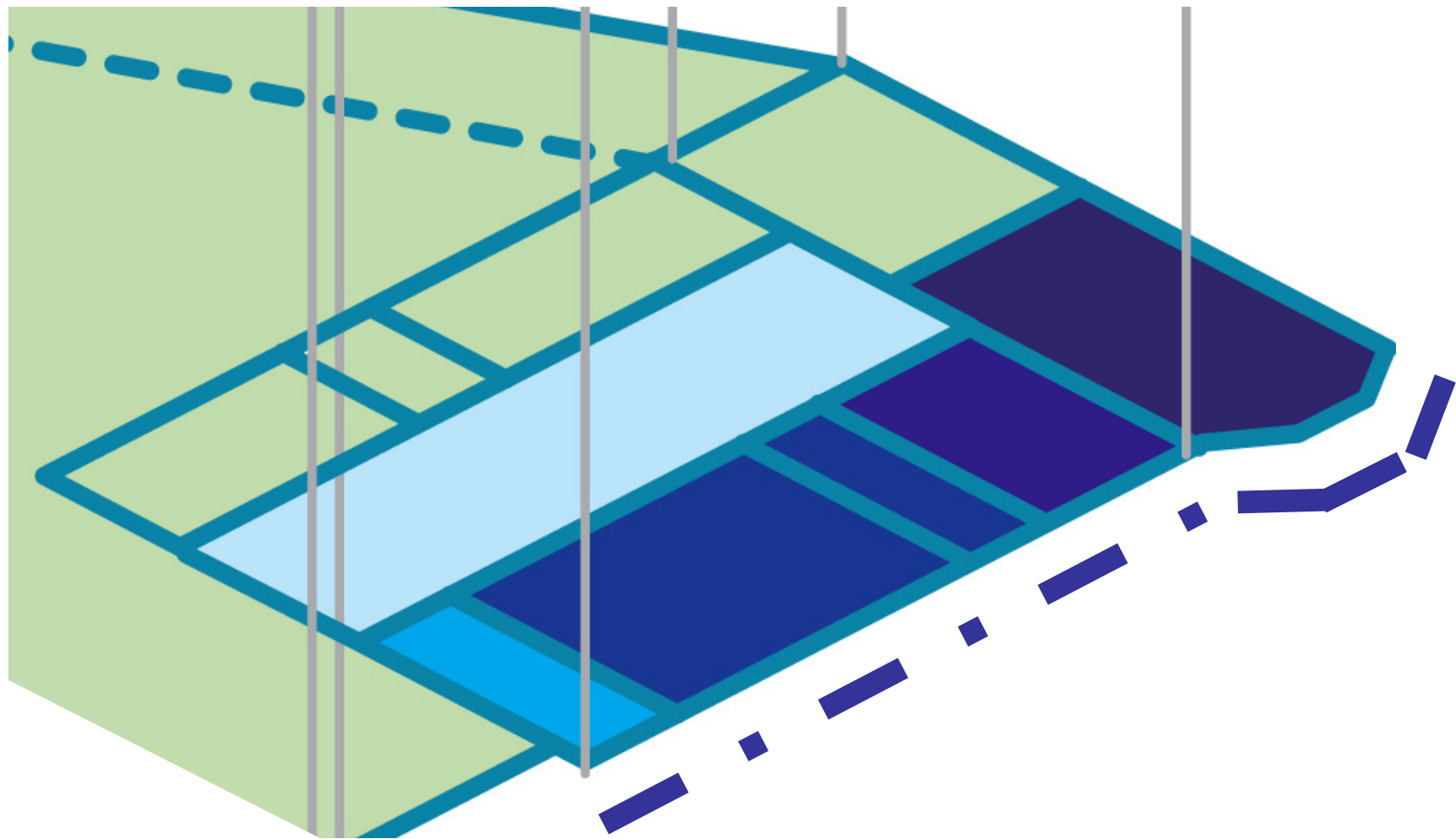



Kleurtrap in paviljoenkamer

<i>fase:</i>	<i>geschatte datering:</i>	<i>koof plafond:</i>	<i>profiellijst kooflijst</i>	<i>kroonlijst linker nis:</i>	<i>buffetnis plafond:</i>	<i>buffetnis rechter wand:</i>	<i>wand rechts venster:</i>	<i>schouwboezem rechtsonder</i>
		0. stuc	0. licht hout	0. licht hout	0. stuc	0. donker hout	0. licht hout	0. hout
I-II	1750-1802		1. bruine houtimitatie		1. verkleurd wit 2. verkleurd wit 3. verkleurd wit		1. bruine houtimitatie	1. okergeel vergulding
III	1803-1837		2. groenblauw		4. blauwgroen 5. blauwgroen			
IV	1838-1884	1. okergeel zwarte contour						
V	1885-1906	2. grijsbruin	3. grijsbruin					2. grijsbruine marmerimitatie
VI	1907-1938	3. bronsgroen		1. crème 2. lichtgroen	6. lichtgroen 7. licht bruingroen	1. crème 2. geelgroen 3. lichtgroen	2. wit 3. geelgroen 4. lichtgroen	3. lichtgroen
VII	1939-1952	4. grijsgroen 5. bruingroen		3. licht geelgroen	8. lichtbruin 9. lichtbruin	4. licht geelgroen	5. licht geelgroen	4. licht geelgroen
VIII	1953-1967	6. lichtgroen		4. donkergroen	10. lichtgroen	5. donkergroen 6. donkergroen	6. wit 7. donkergroen 8. donkergroen	5. donkergroen
IX	1968-1986	7. crème		5. wit 6. lichtgrijs 7. crème	11. crème	7. crème	9. wit 10. crème	6. wit 7. crème
X	1987-1990			8. wit 9. licht blauwgroen		8. wit 9. grijsbruin 10. licht blauwgroen	11. licht blauwgroen	8. licht blauwgroen
XI	1991-2011	8. wit	3. grijsgroen	10. grijsgroen	12. wit	11. wit 12. grijsgroen	12. grijsgroen	9. grijsgroen



Voorgevel (voor)



Voorgevel (na)



Stijkamer (voor)



Stijlkamer (na)



Paviljoenkamer (voor)



Paviljoenkamer (na)

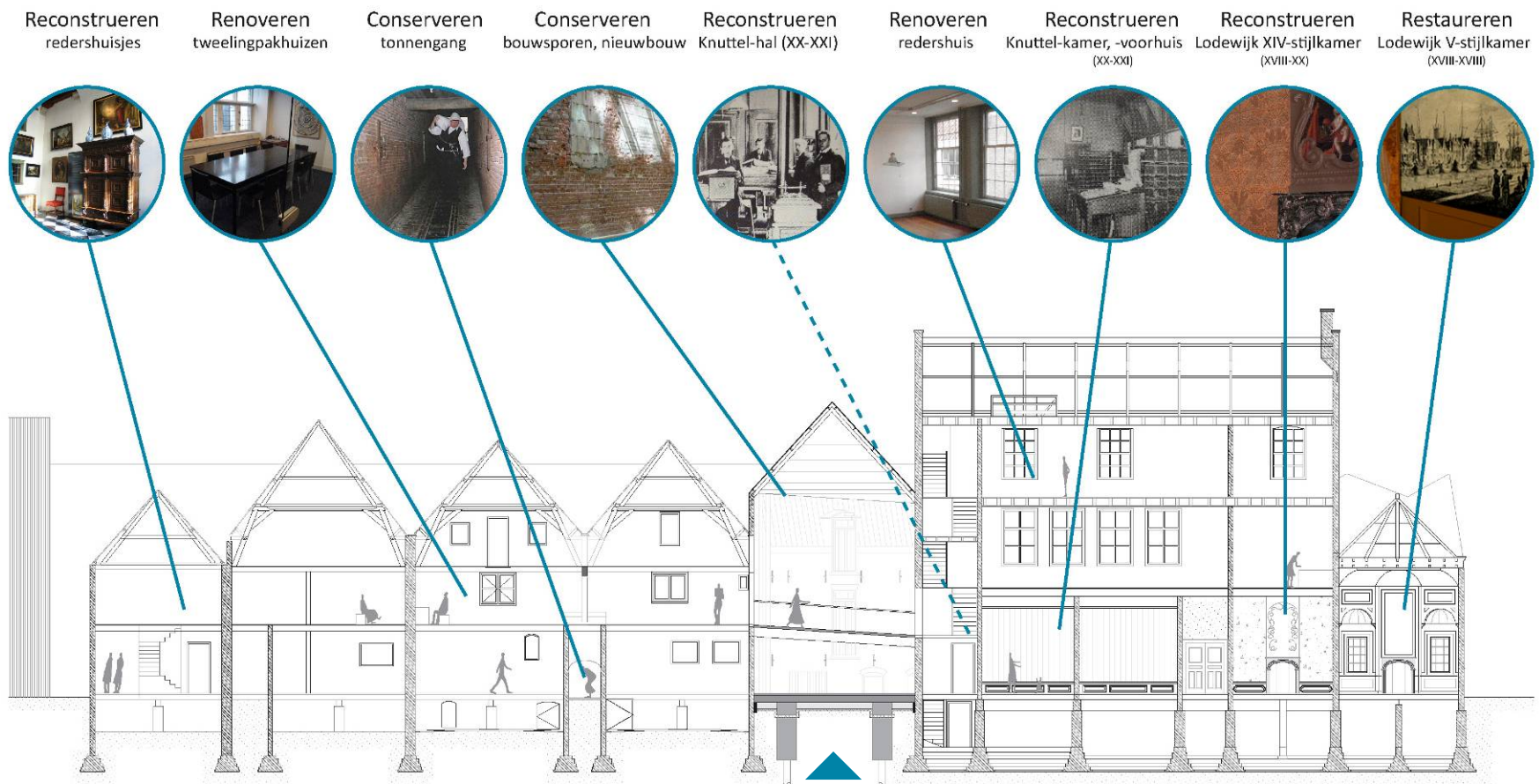

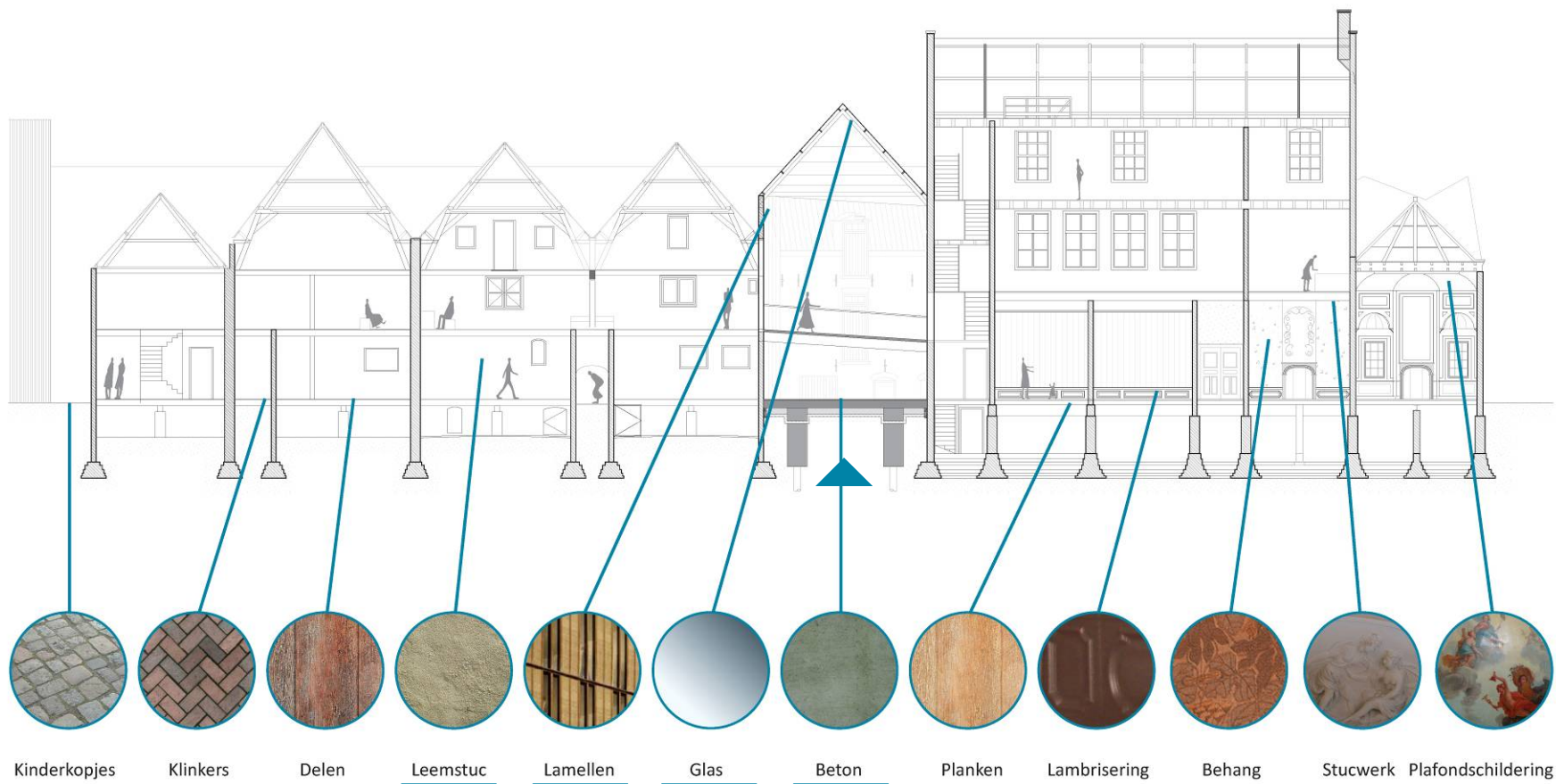



Schade bij pakhuizen



Kuipers rond 1900



Foto van zout in pakhuizen en doorsnede stuc op wand



Uitladen van zout

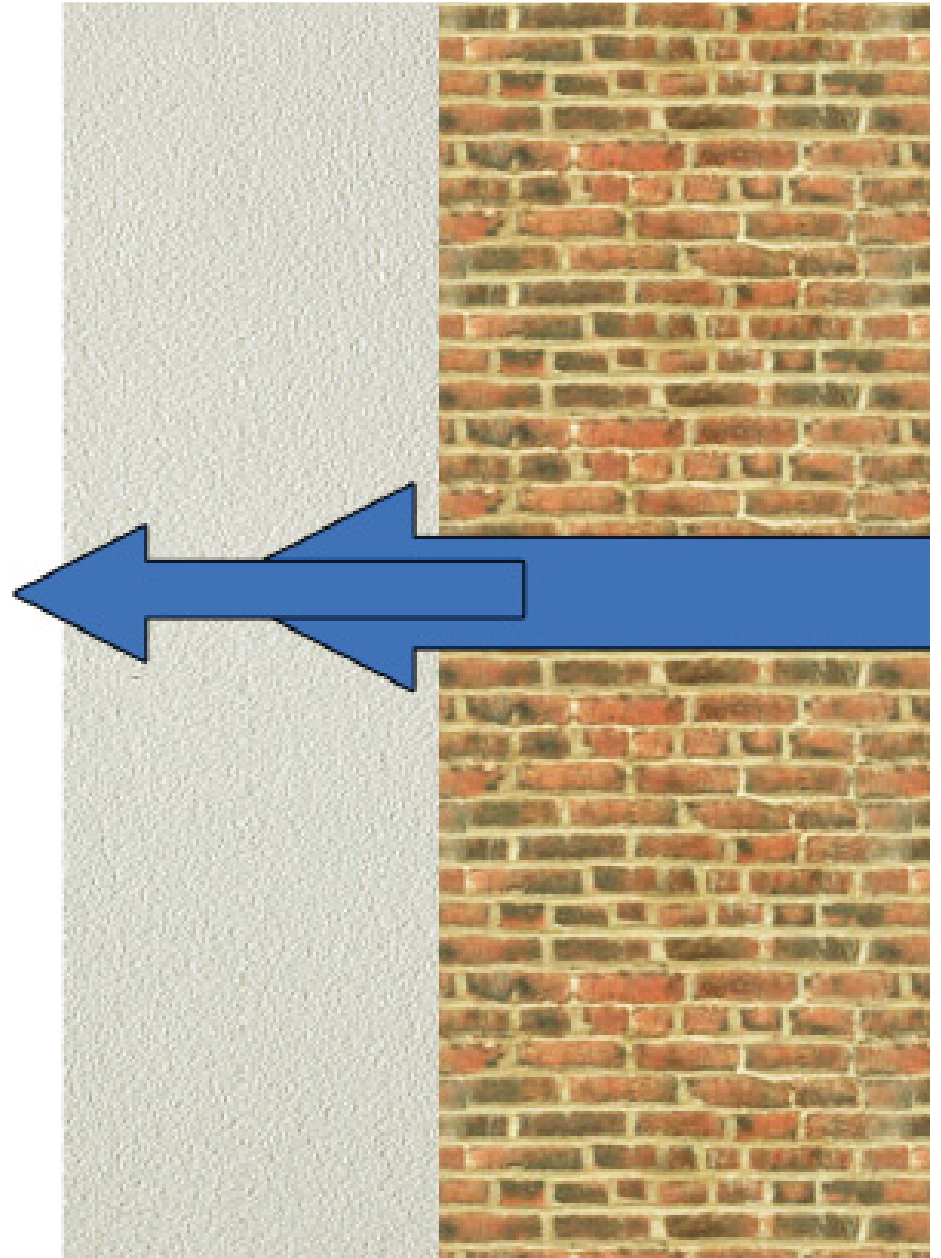

Tonnengang



Tonnengang

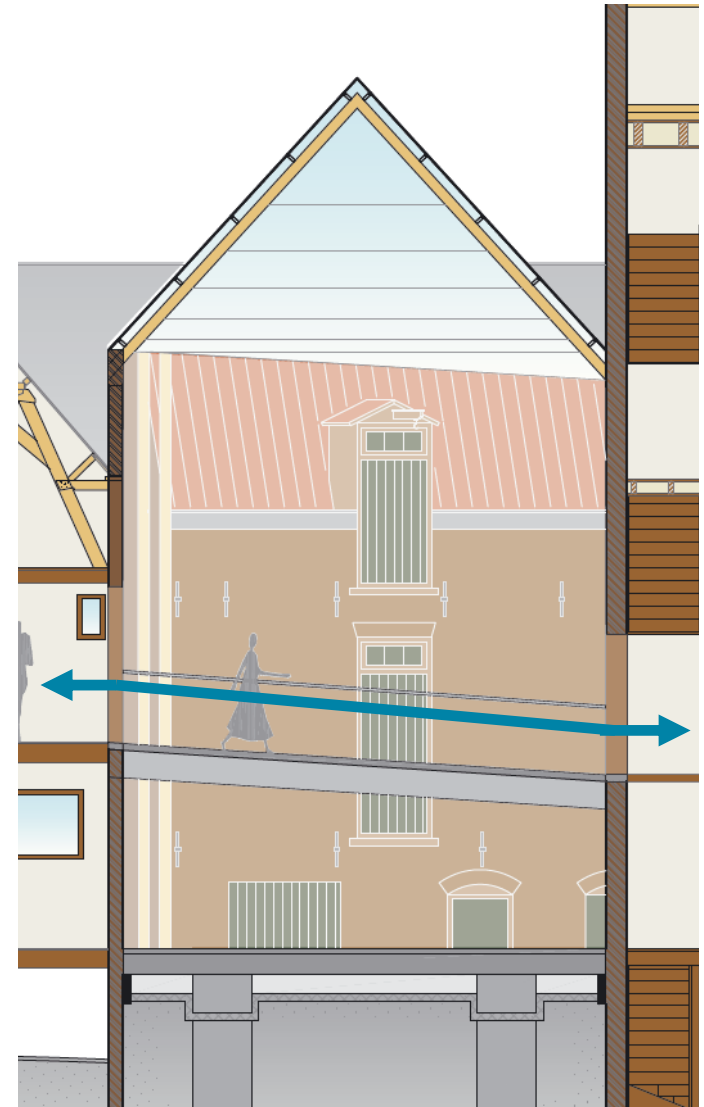

Doorsneden bij loopbruggen

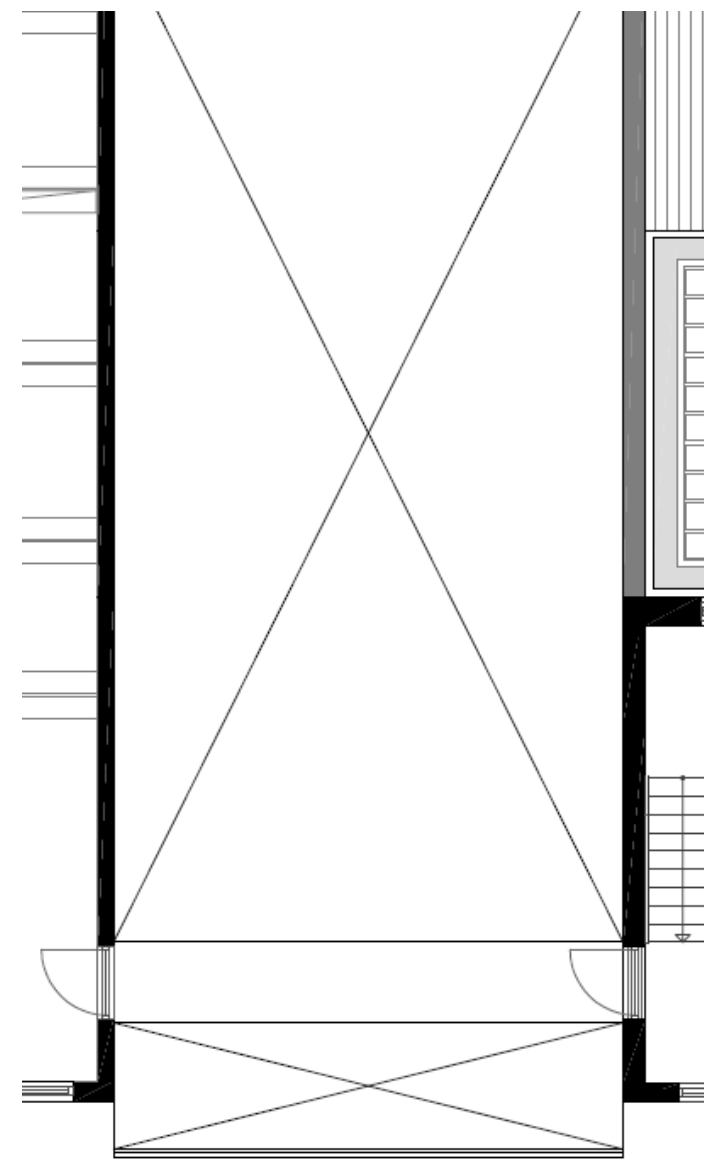
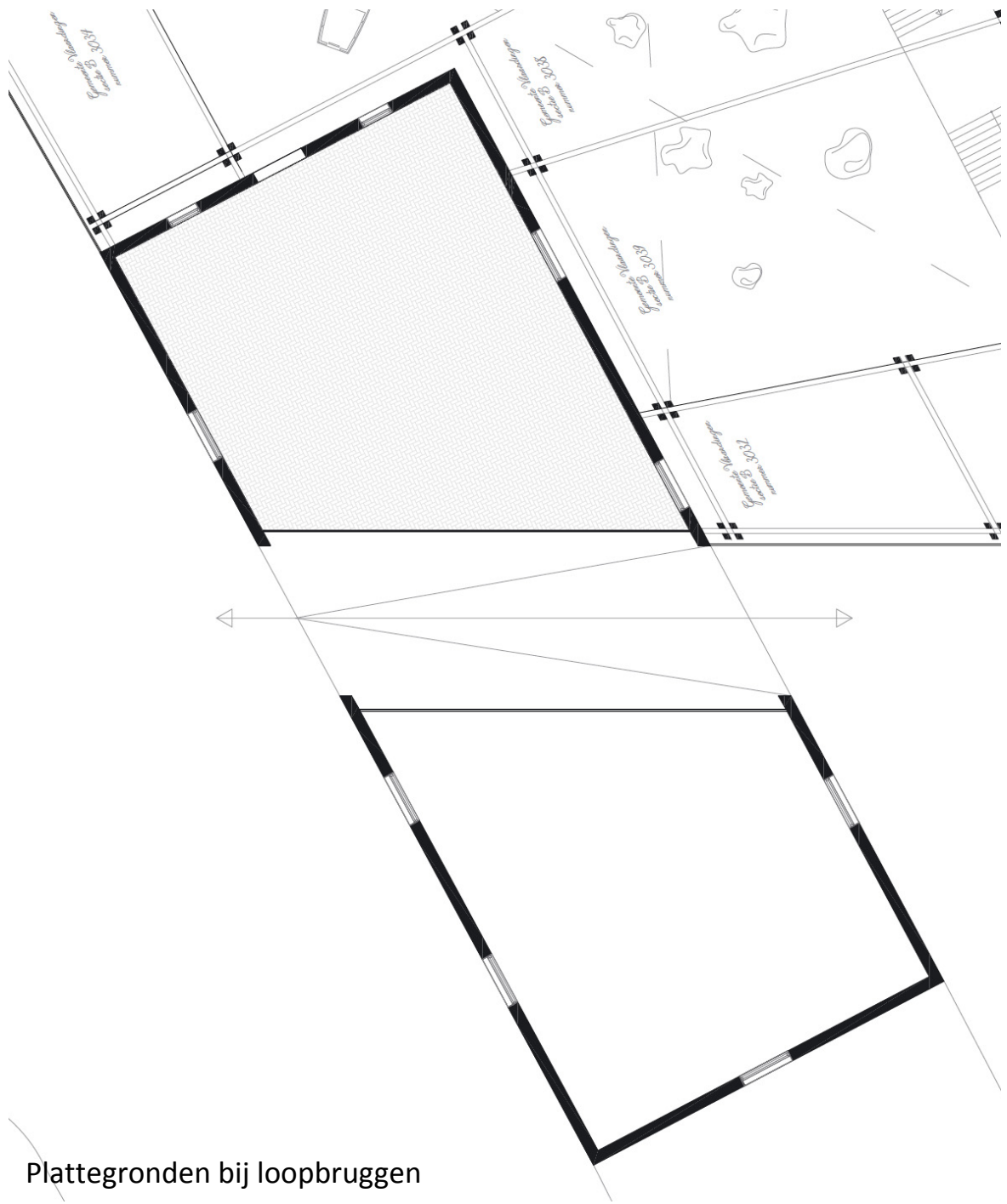

Plattegronden bij loopbruggen



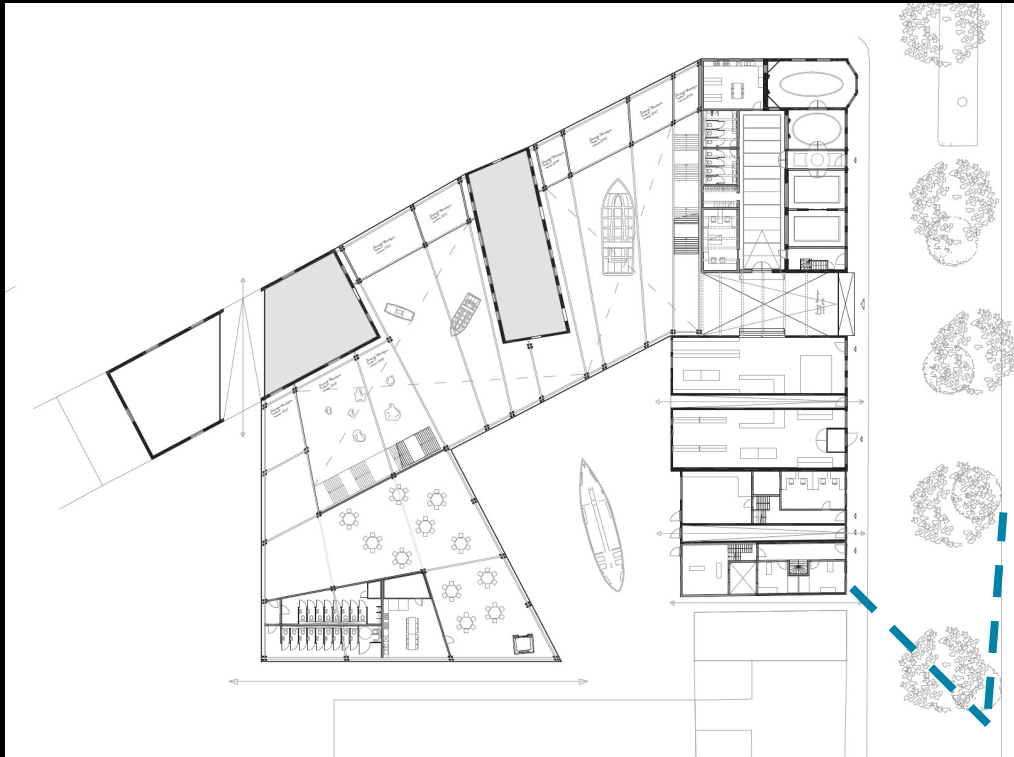



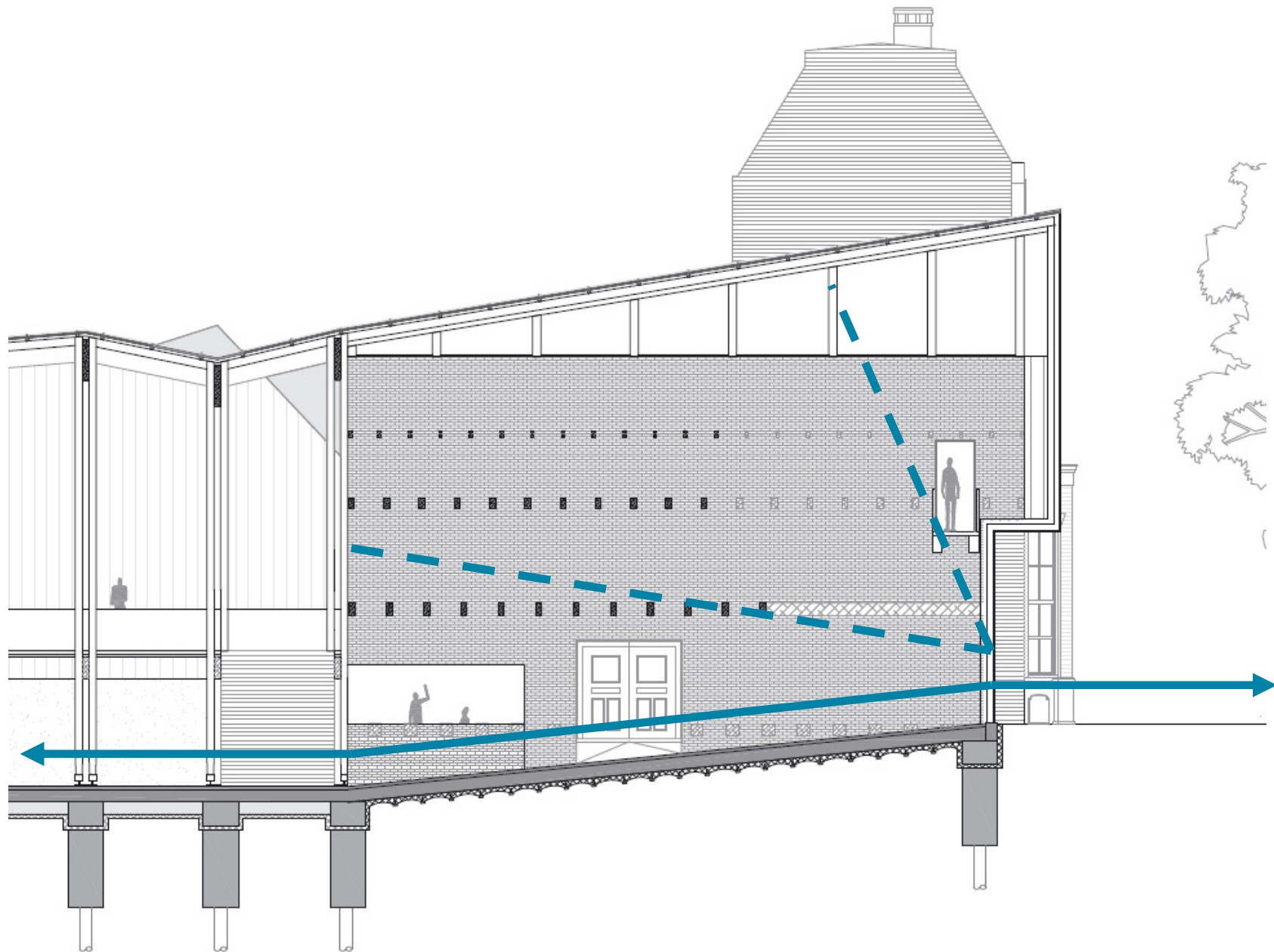

Doorsnede over entree

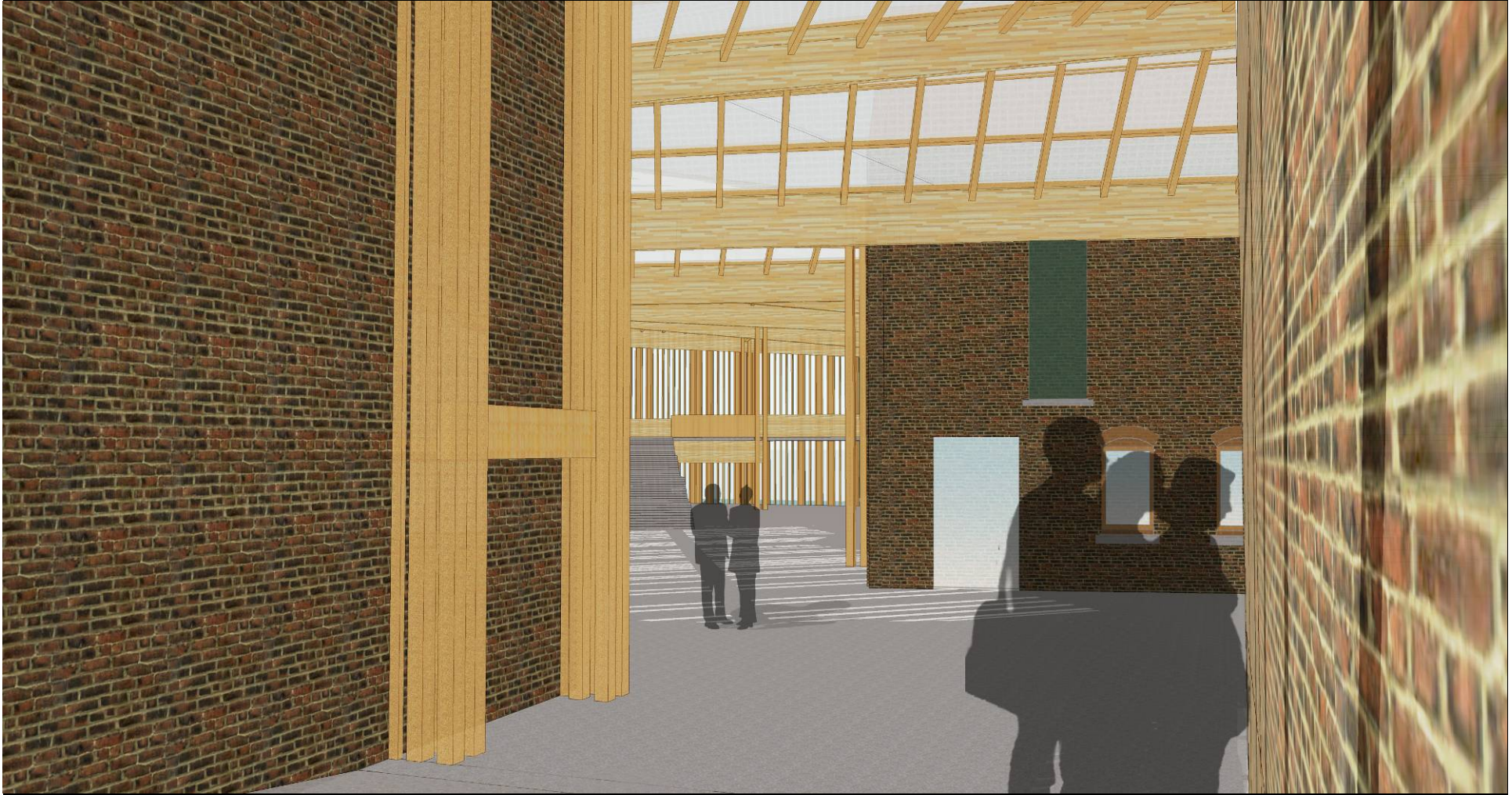



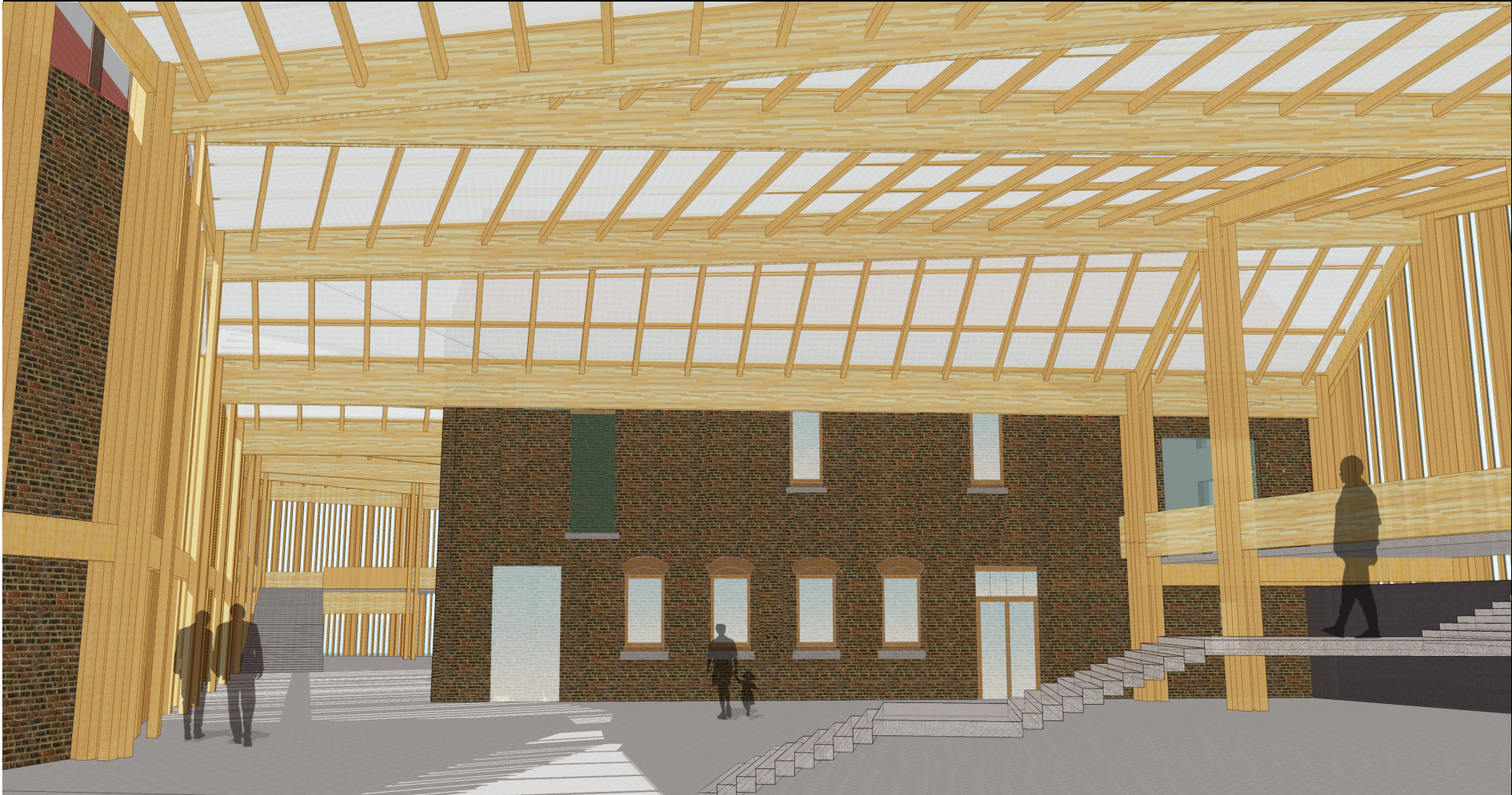



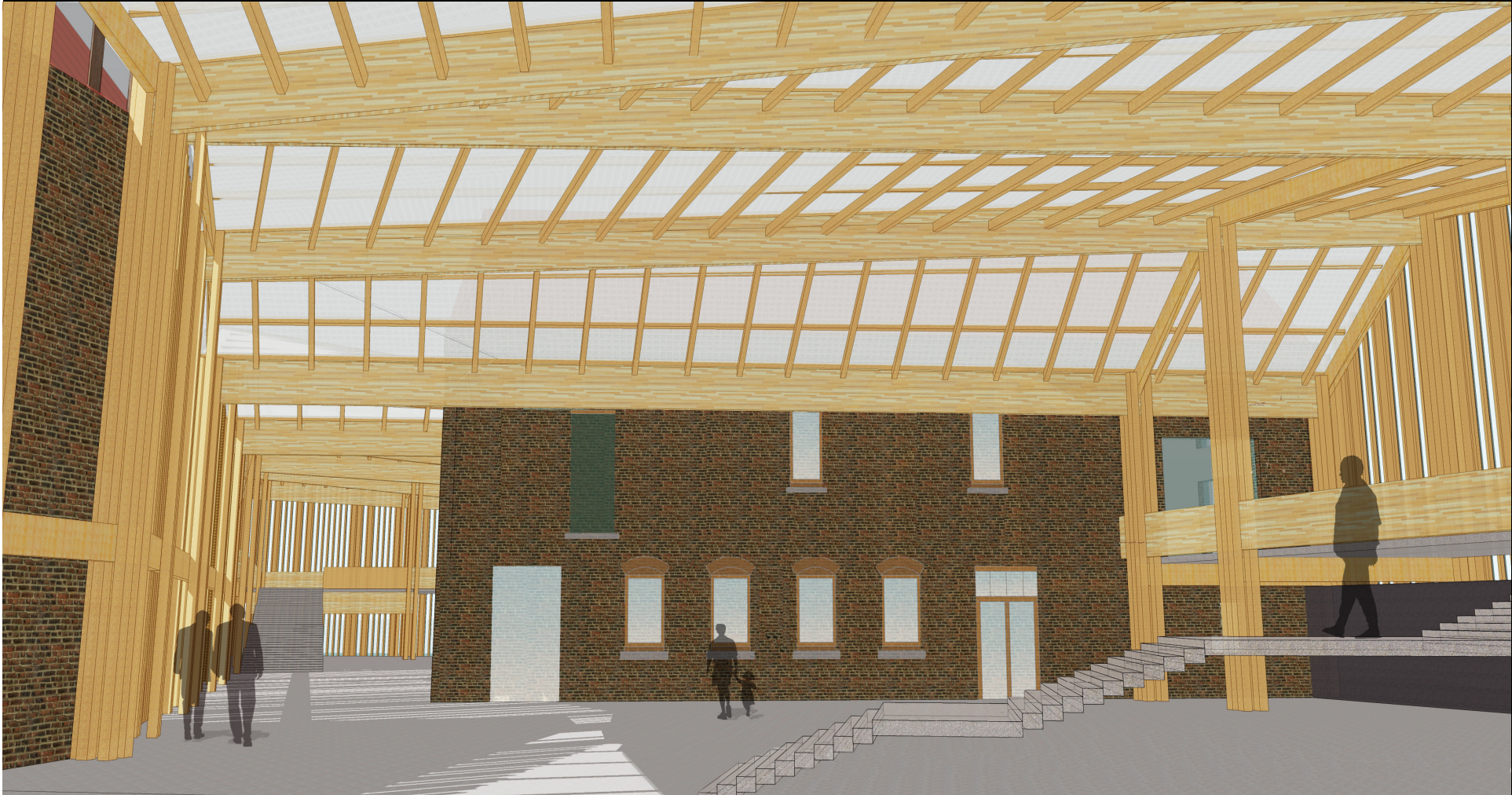

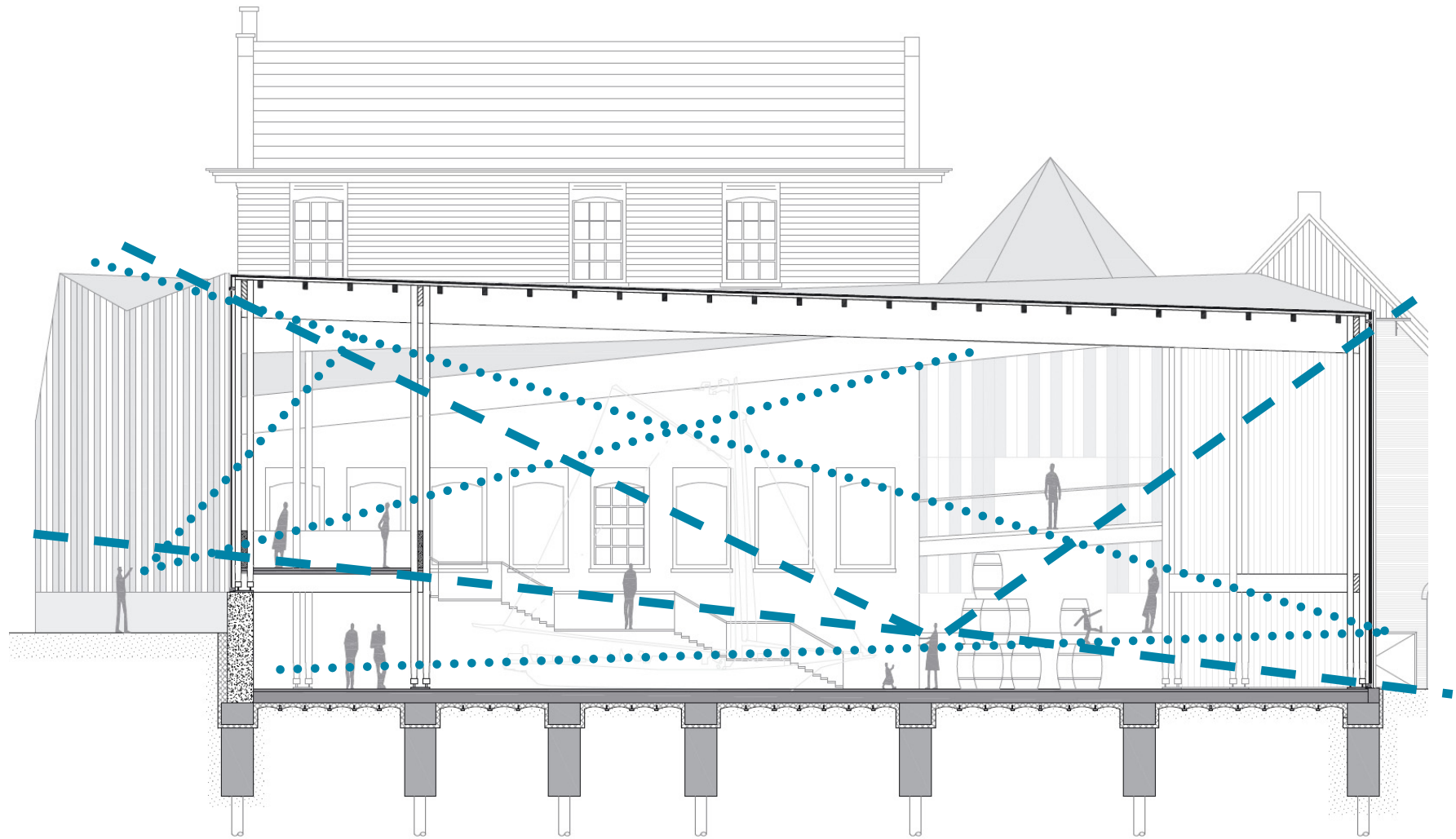

Doorsnede over hal

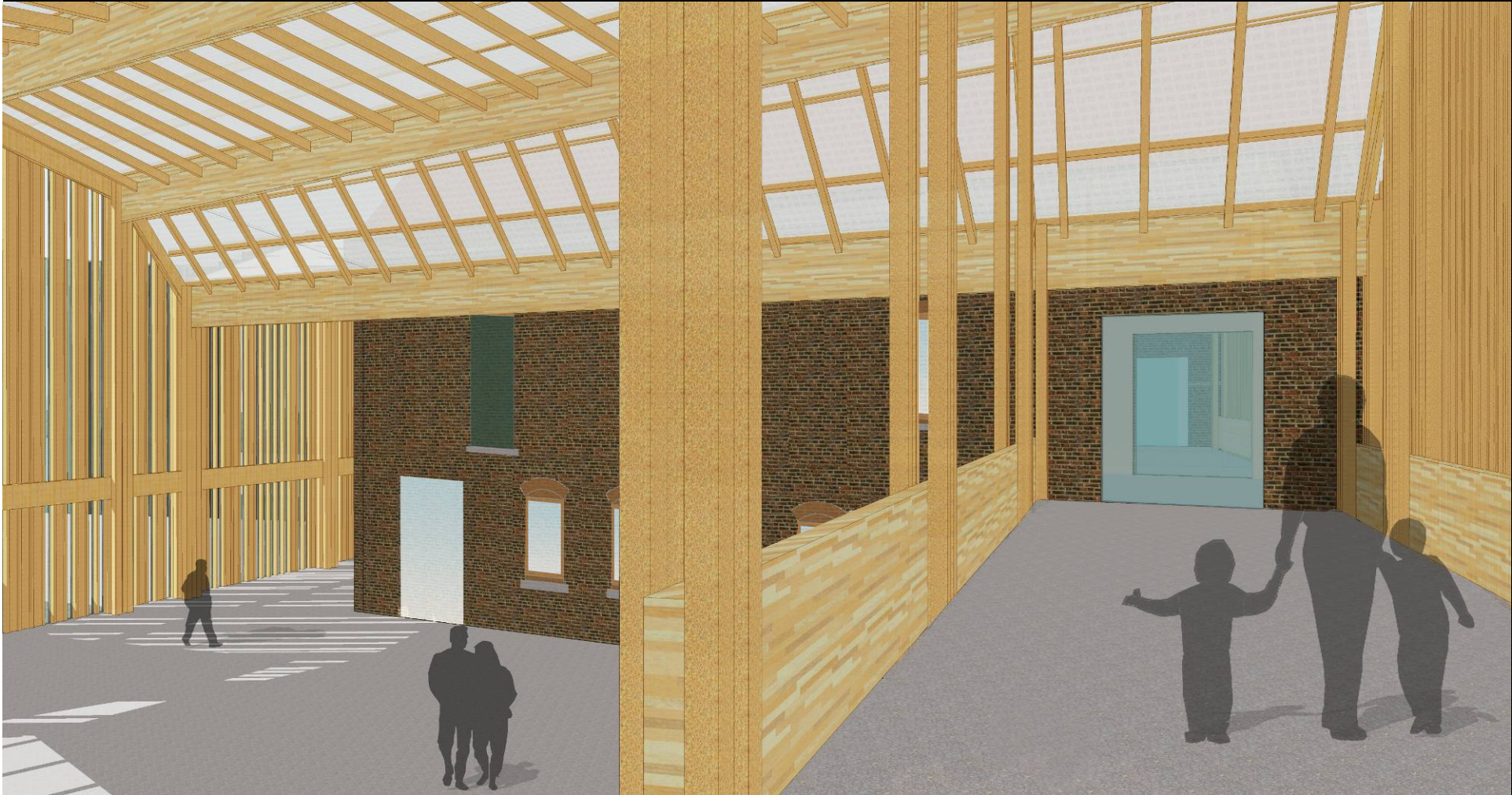

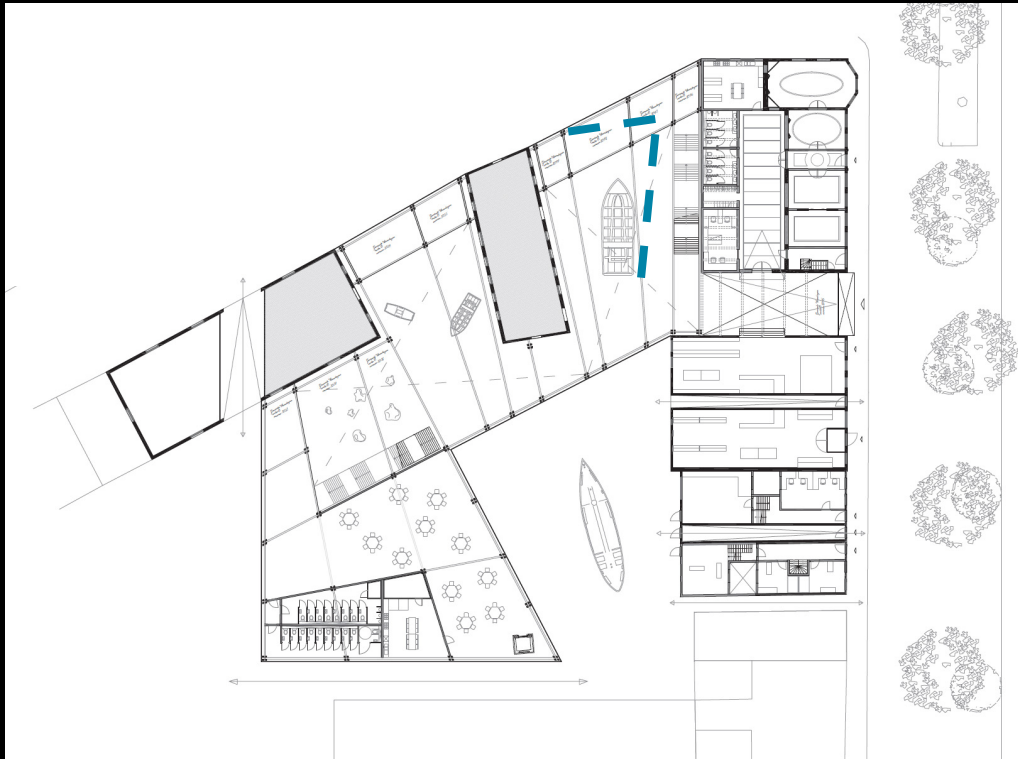



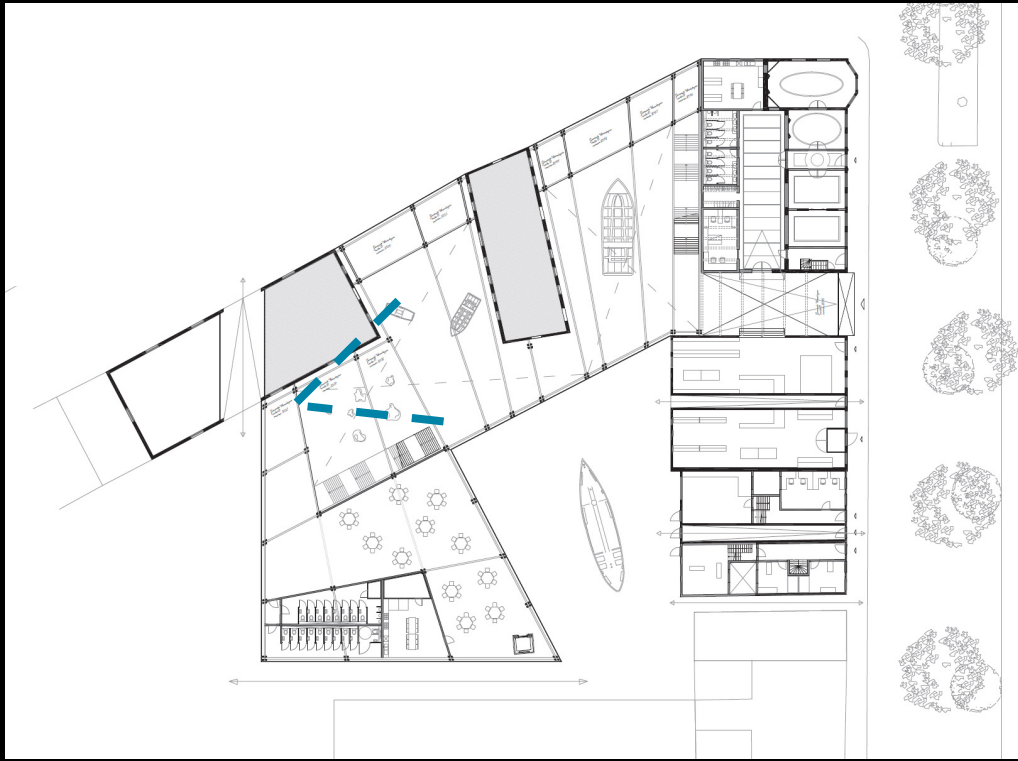



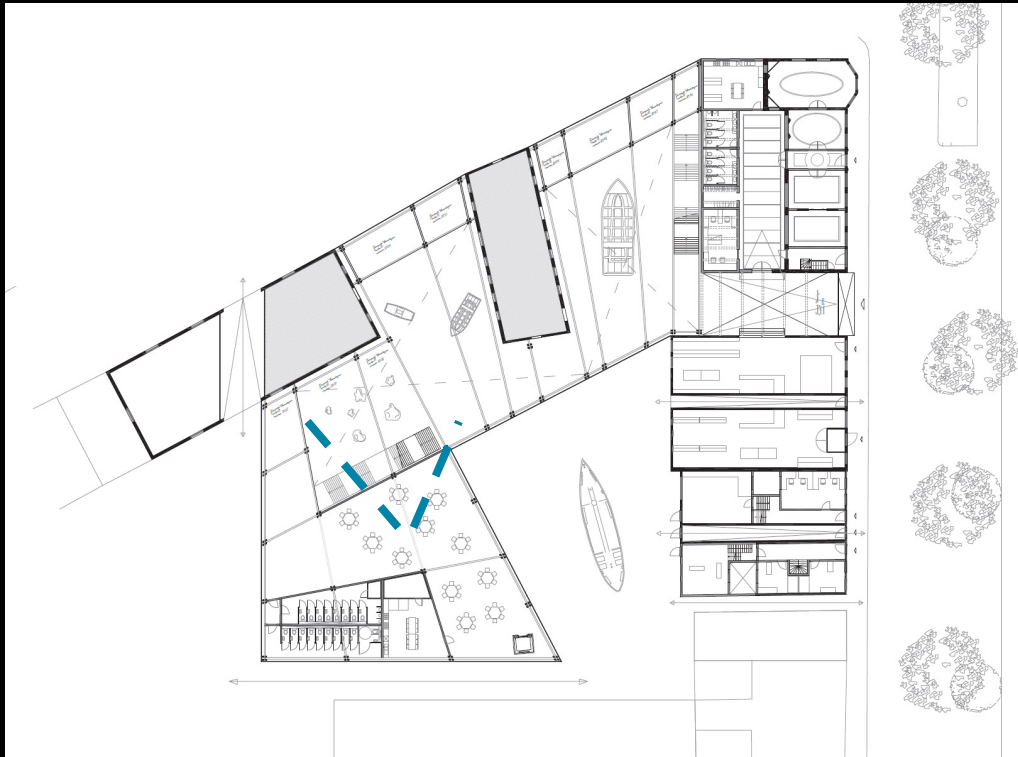

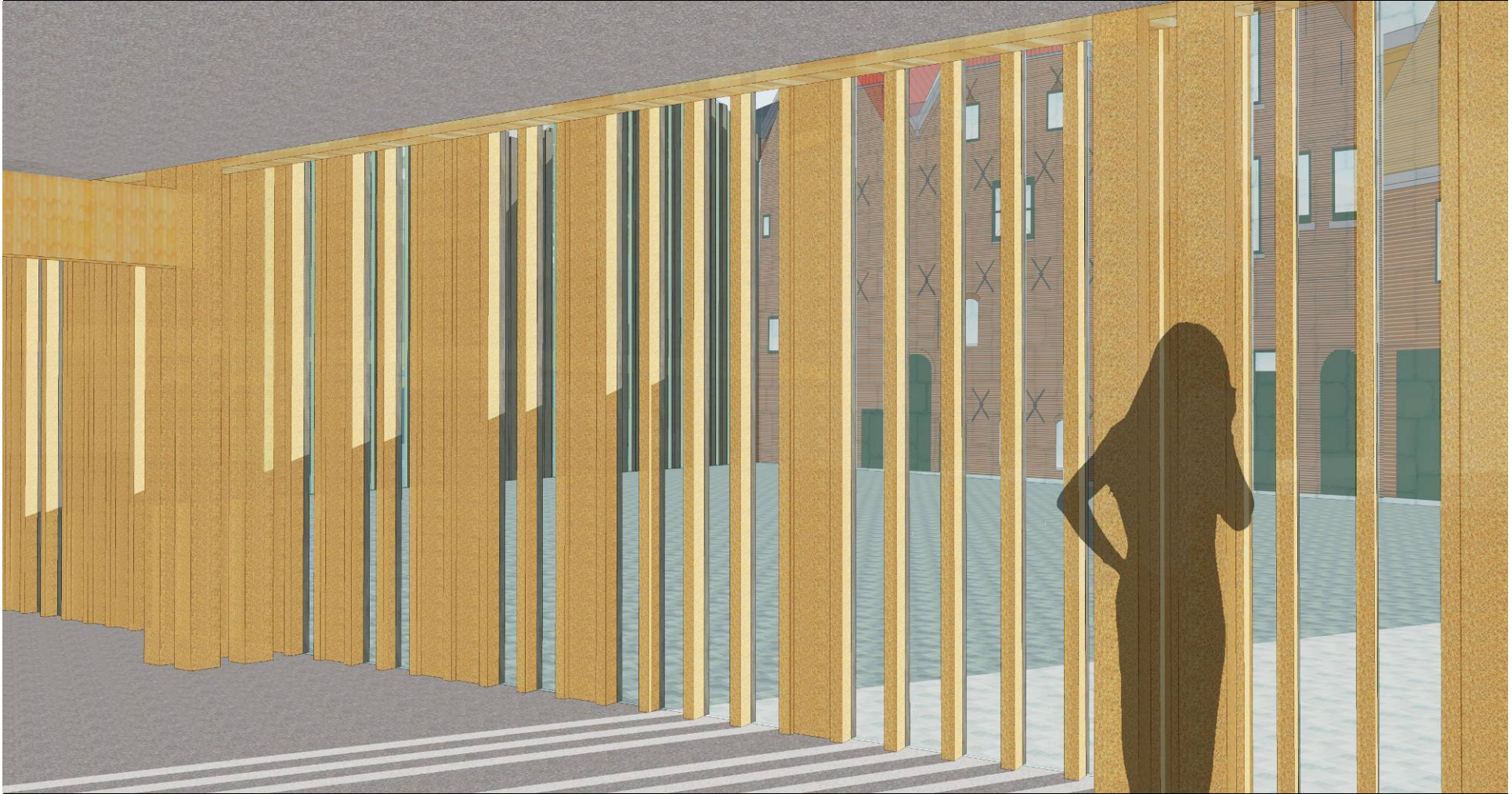

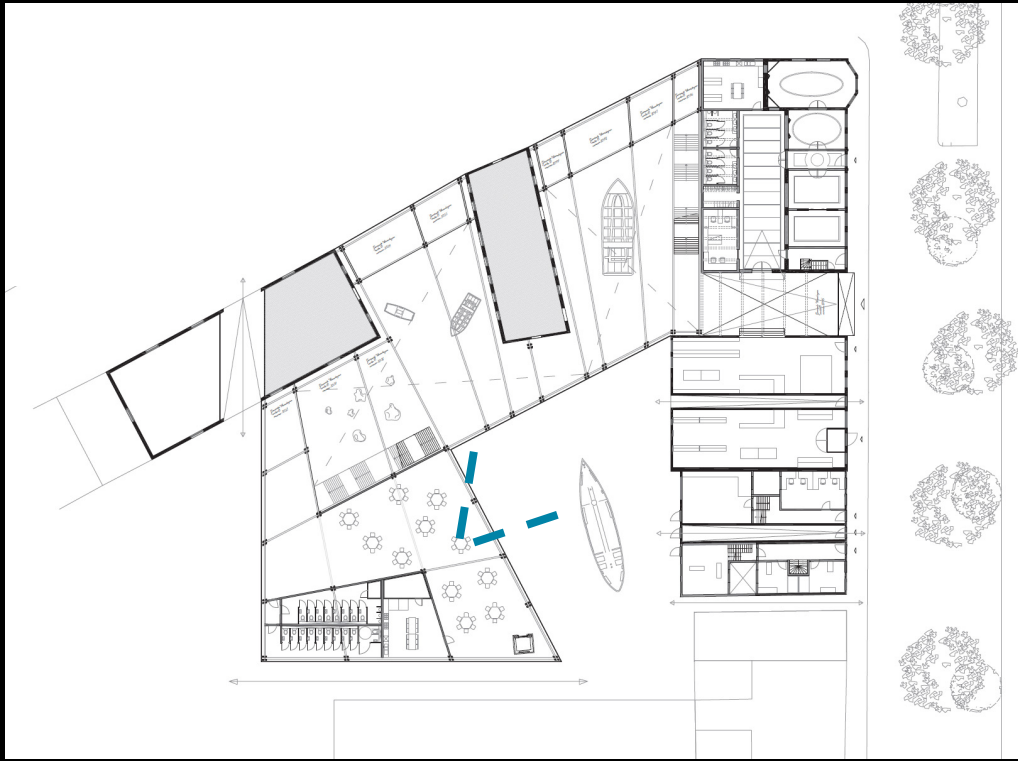

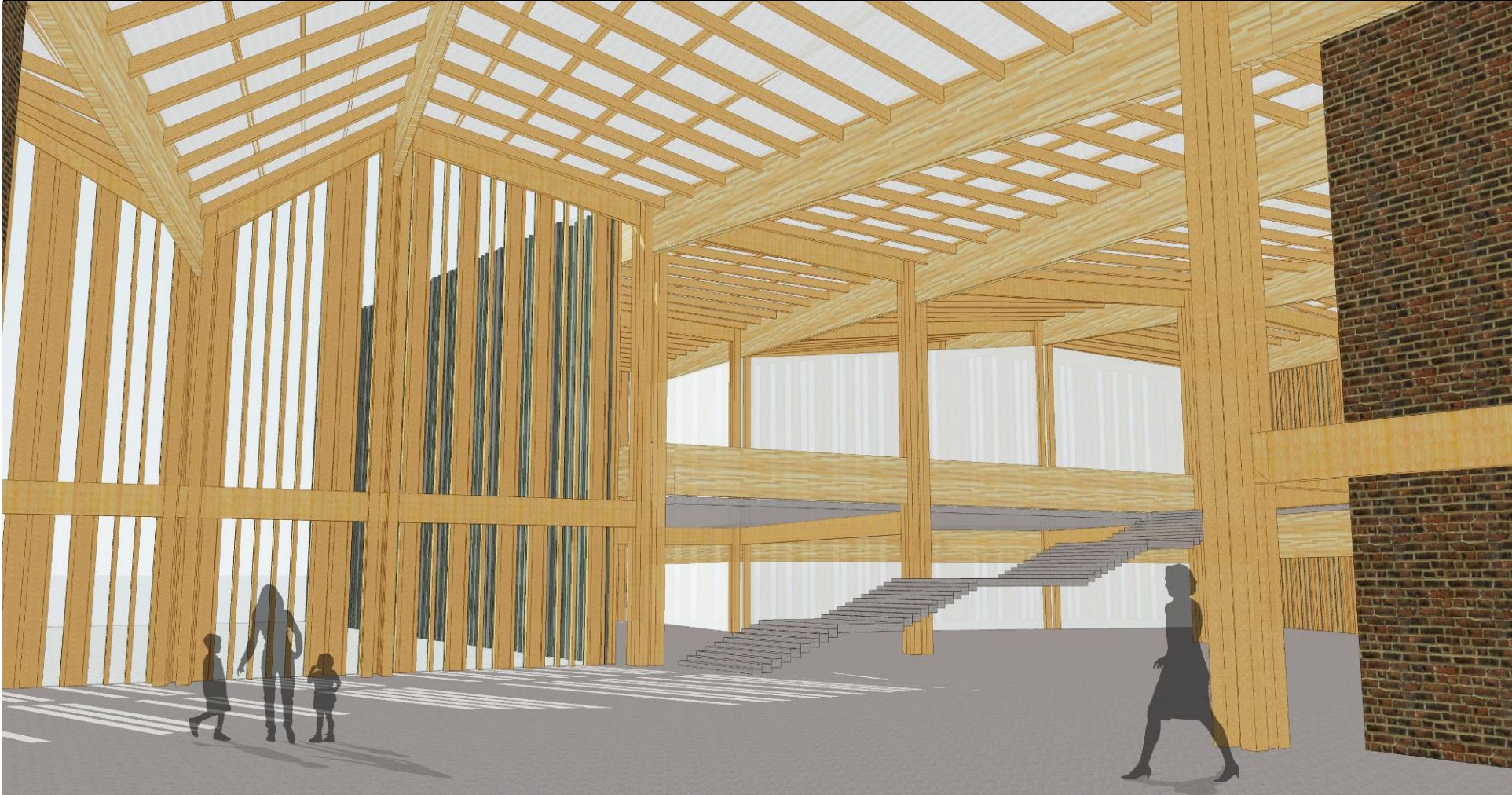

Overzicht hal

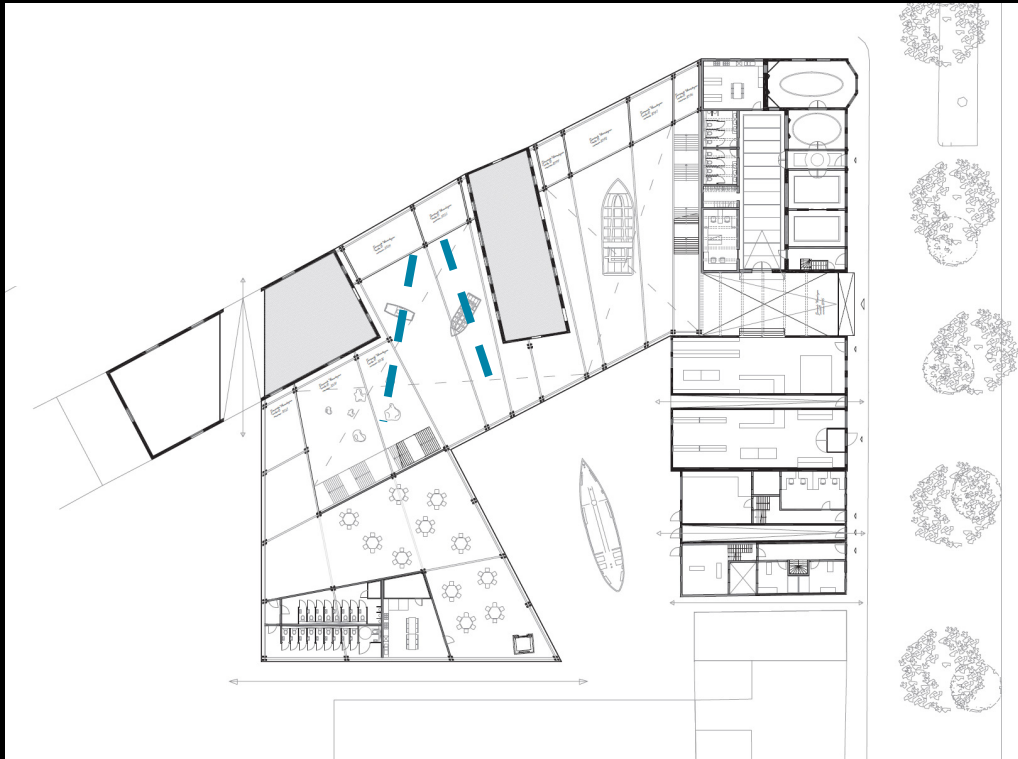

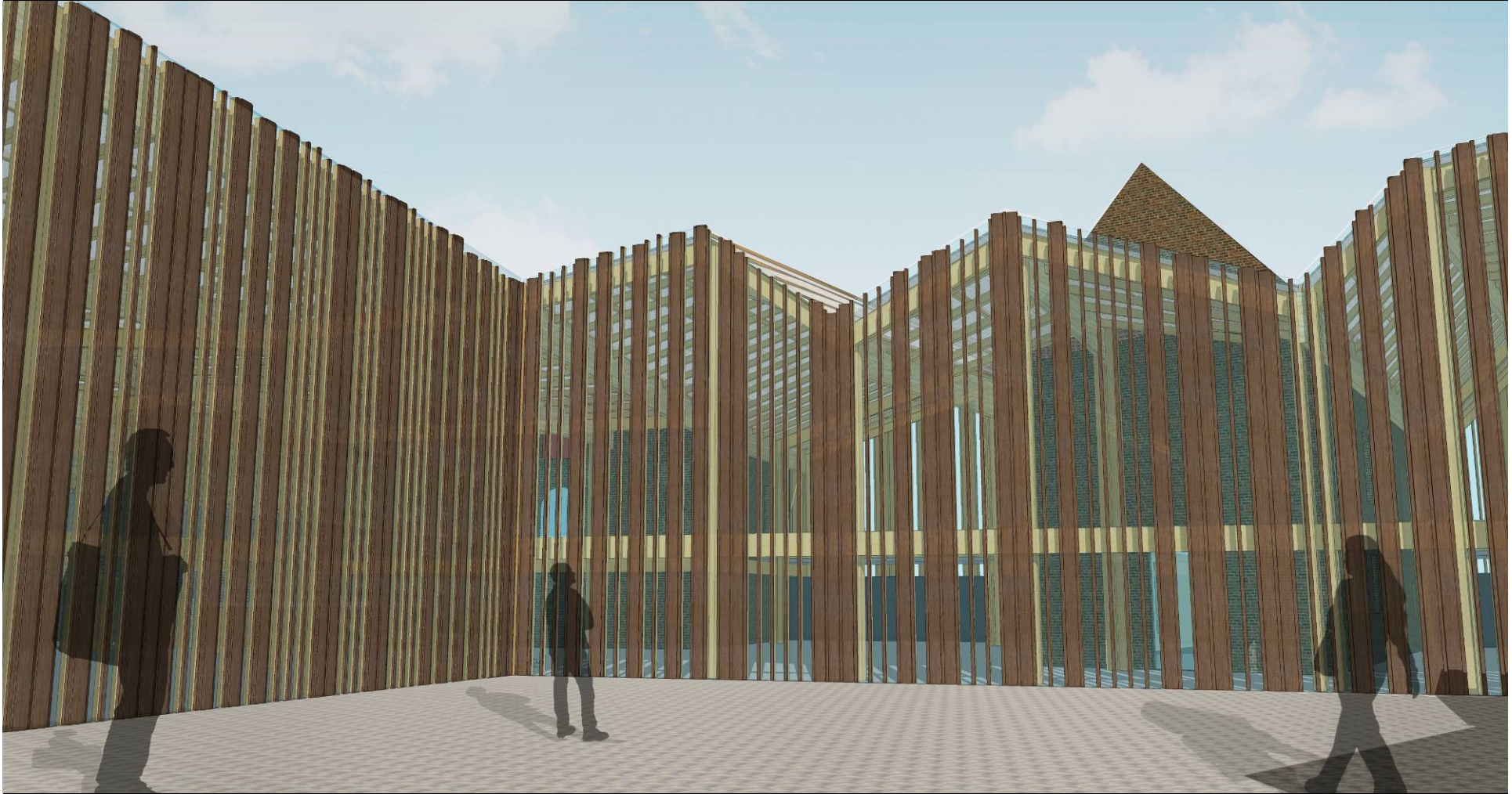



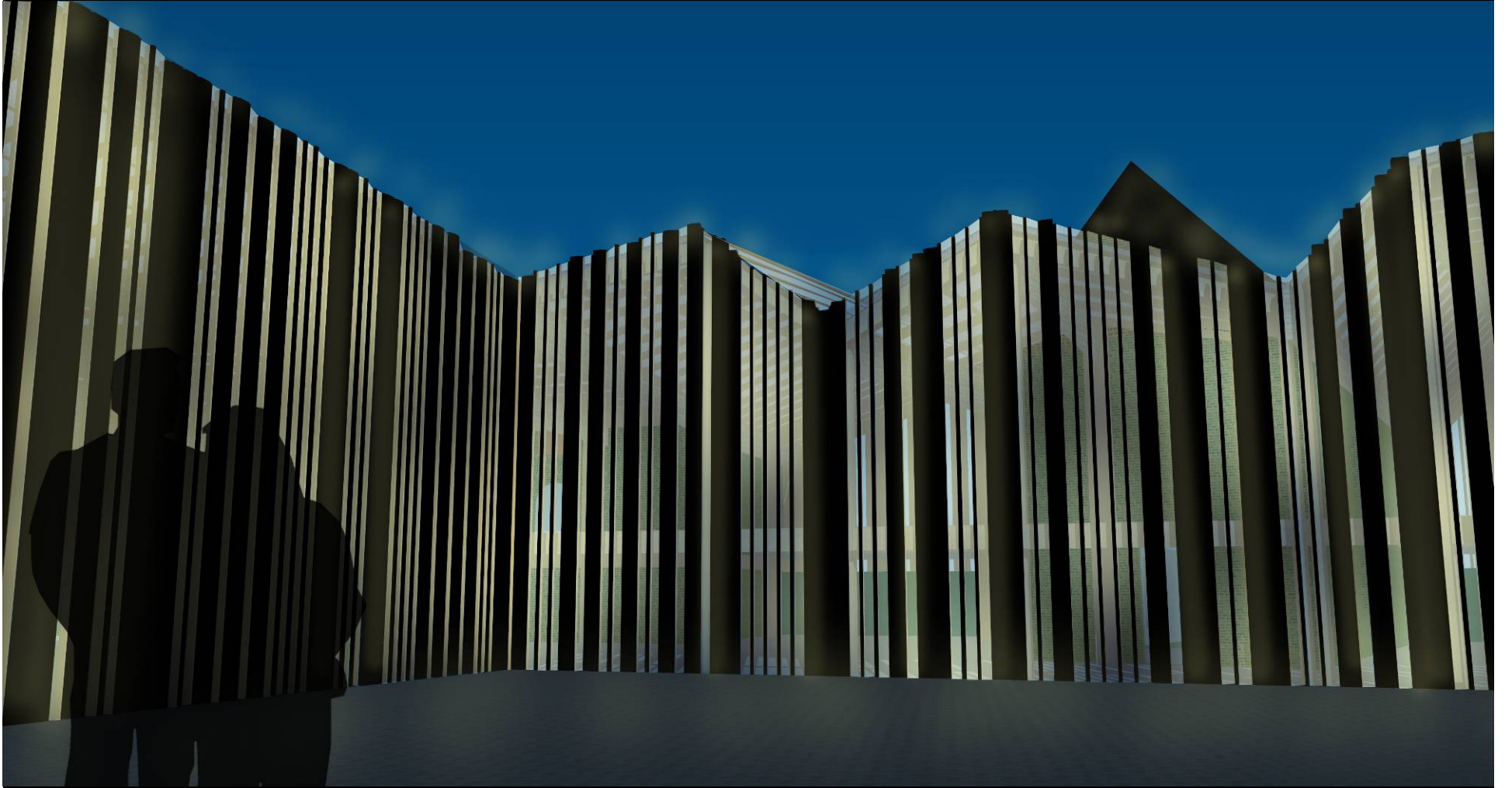





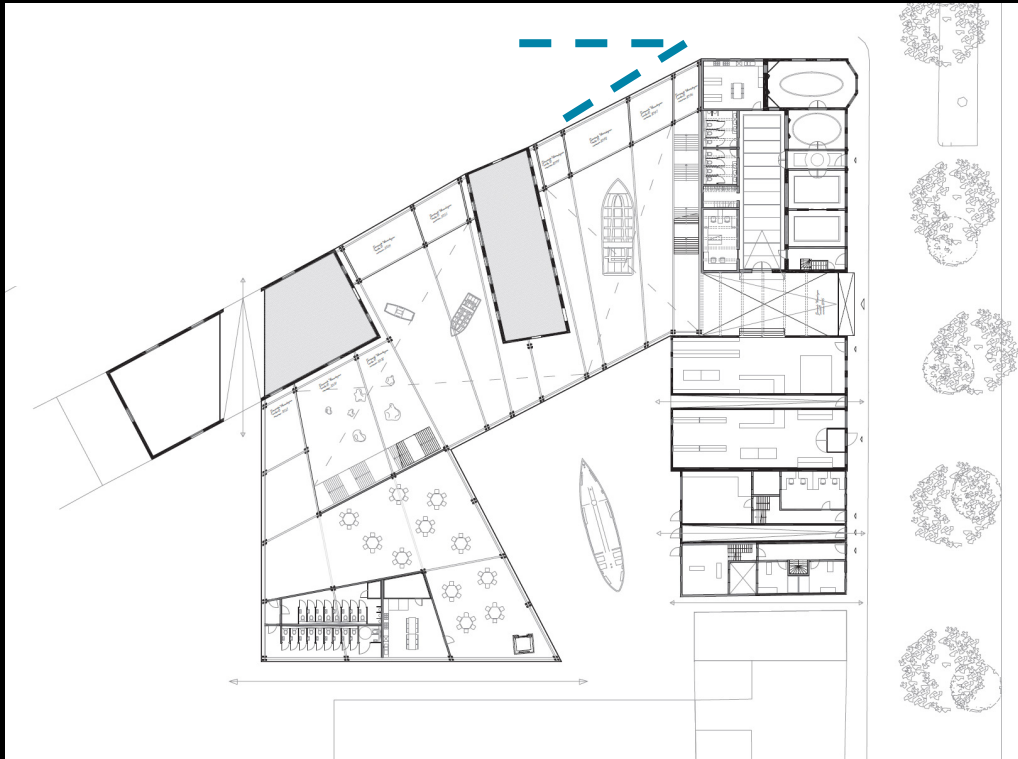

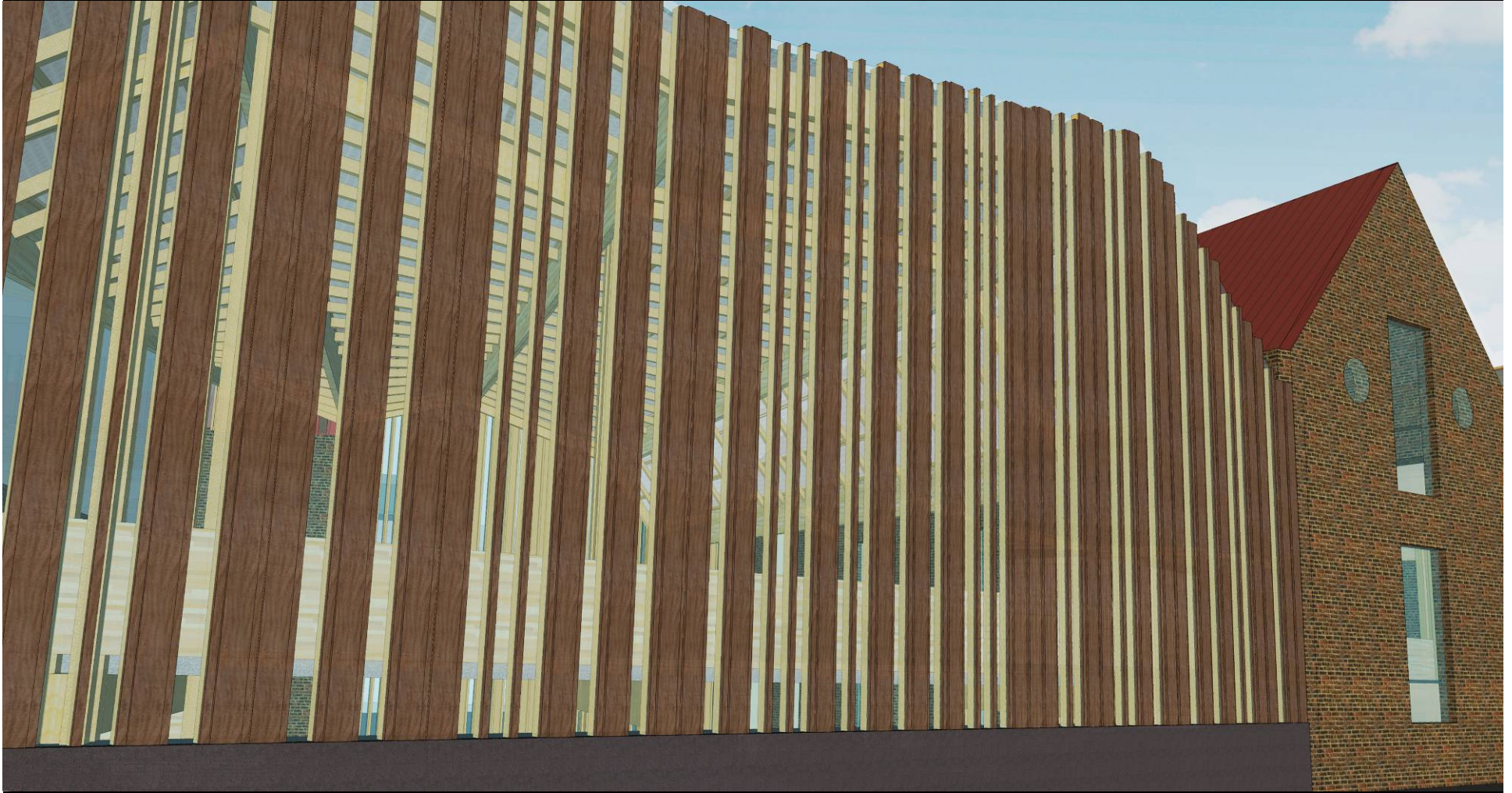

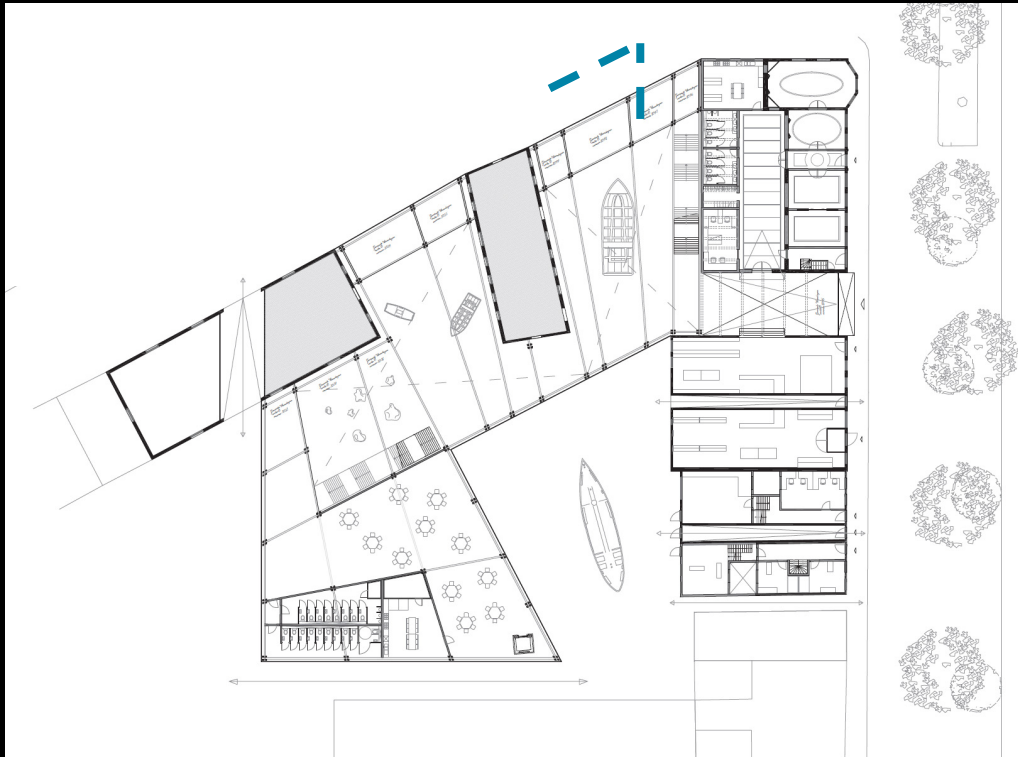

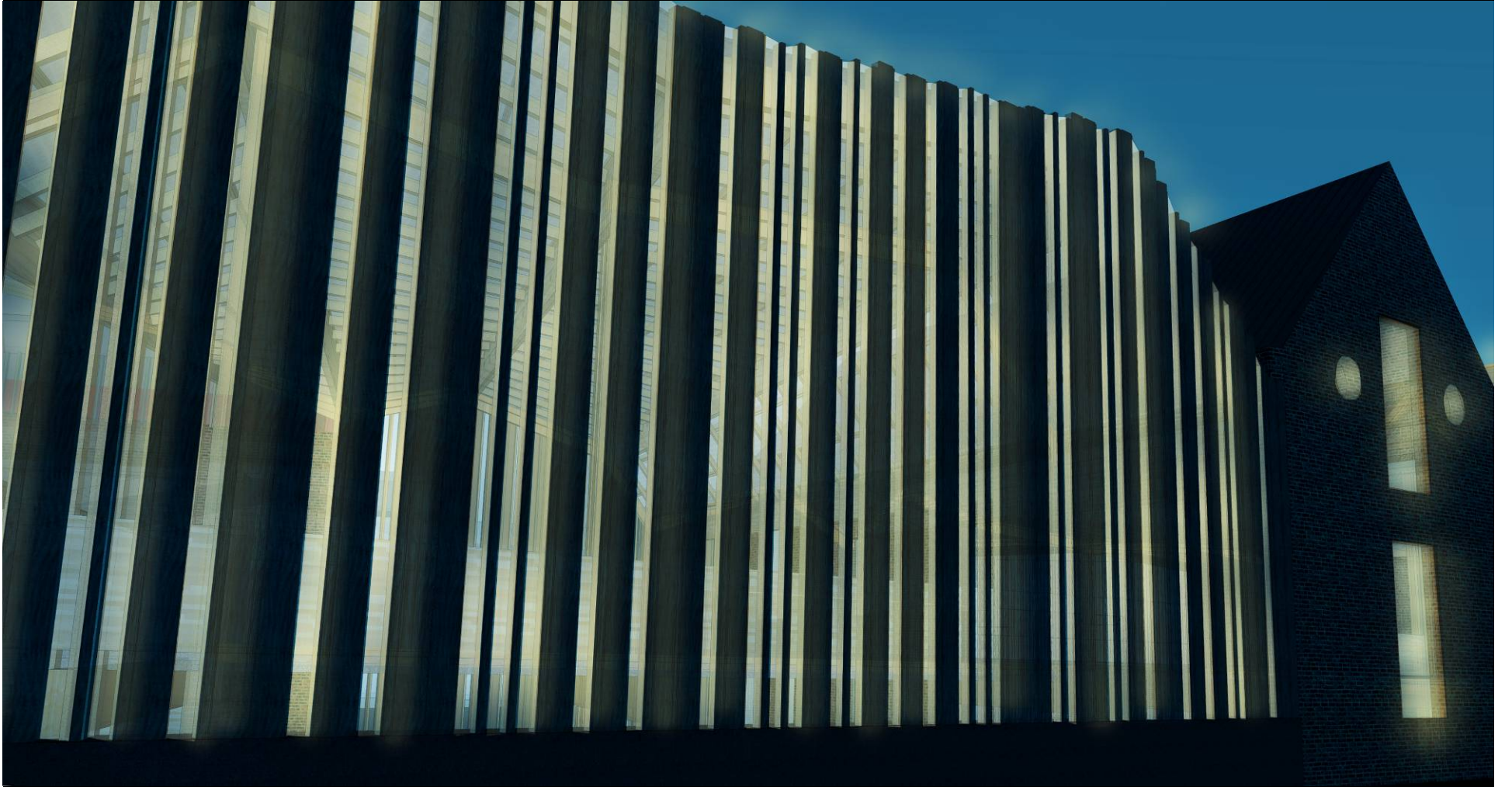

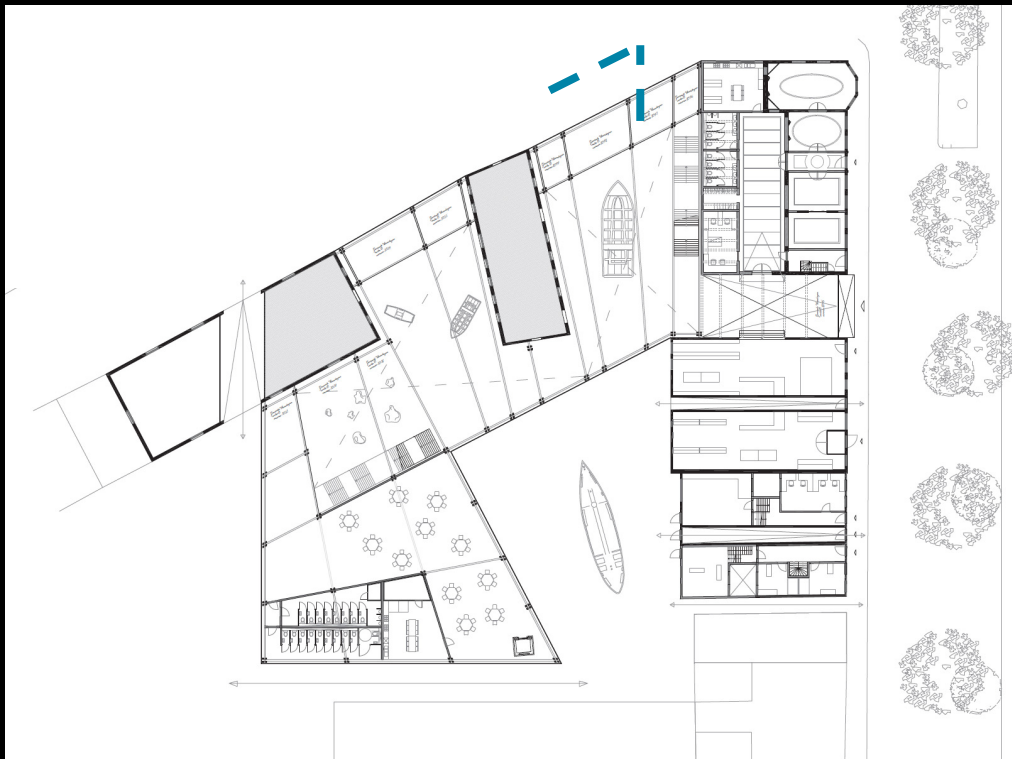



Museum



Restauratie



Vlaardingen



Redershuis

*“A cup of **coffee** [is] the first thing
you want in most museums;
you feel **so tired immediately.**”*

– Louis Kahn



Haven en zicht op redershuis, rond 1900



Haringfestijn in Vlaardingen



E.C. van der A | 1256521 | AR4AX300- EXPLORE-LAB | P5 | 07.11.2012

Mentoren: H.C. Brouwer | E.J.G.C. van Dooren | A.J. van Bommel | | Gecommitteerde: D. Vitner

94 | 94

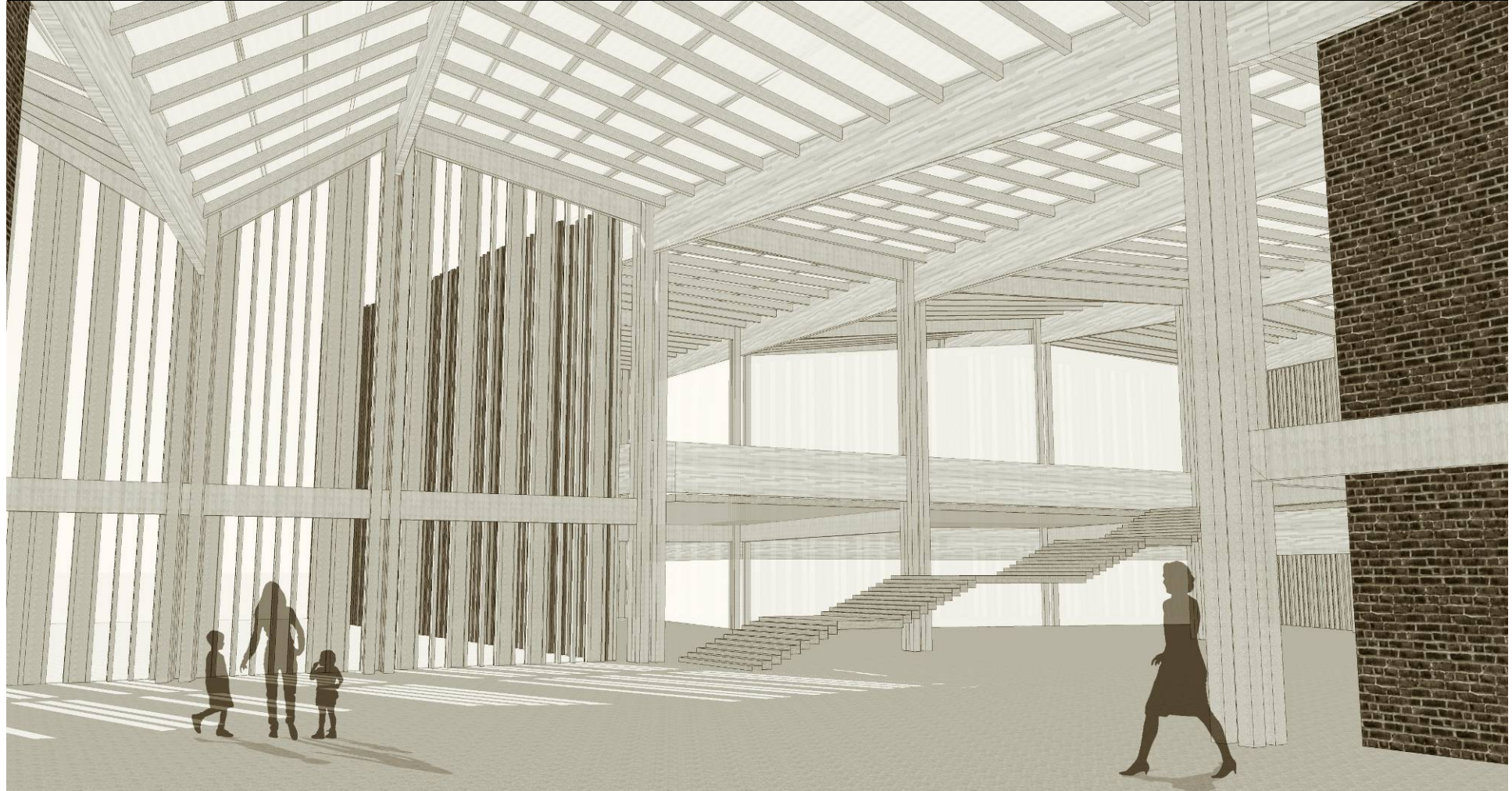

E.C. van der A | 1256521 | AR4AX300- EXPLORE-LAB | P5 | 07.11.2012

Mentoren: H.C. Brouwer | E.J.G.C. van Dooren | A.J. van Bommel | | Gecommitteerde: D. Vitner

94 | 94