

A SURVEY OF ARTIFACT-SIMULATION APPROACHES FROM THE PERSPECTIVE OF APPLICATION TO USE PROCESSES OF CONSUMER DURABLES

Wilhelm Frederik (Wilfred) van der Vegte

Faculty of Industrial Design Engineering
Delft University of technology
The Netherlands
w.f.vandervegte@tudelft.nl

ABSTRACT

In this paper, approaches for artifact-behavior simulation are reviewed. The motivation behind the survey is to explore available knowledge for the development of a new form of computer support for conceptual design to simulate use processes of consumer durables. The survey covers the simulation of artifacts both as discrete systems and as continuous systems. Simulation approaches are characterized based on the simulation models and reviewed based on criteria including the range of behaviors covered, ease of preparation and ease of interpretation. Based on the criteria, simulations based on 3D discretized models seem to have the most to offer, but they cannot provide a complete picture of artifact behavior and preparing models can be computation intensive. Options for improvement are briefly discussed, but the first next step will be to extend the knowledge exploration by surveying approaches for simulation that cover human behavior.

KEYWORDS

Artifact-behavior simulation, design for use, conceptual design, consumer durables.

1. INTRODUCTION

A key process of a product's life cycle is the use process. Use has been defined in various dictionaries, as 'to put into service or apply for a purpose'. During product design, simulation is frequently used to gain insight into the course of processes in which the product is involved. The early phases of design form an application area where deployment of various simulation methods is expected to open up new opportunities to optimize products for use. A simulation is an experiment performed on a model (Korn, G.A. and Wait, J.V., 1978). In industrial product design, the simulation model of a product is typically called prototype. This can be a physical prototype, a virtual prototype or an augmented prototype. In the beginning of the design process, virtual prototypes are pre-

ferred because they are easier to create than physical or augmented ones. A virtual prototype is a non-real, digital prototype modeled and visualized using a computer (Eggert, R.J., 2005). To gain insight into use of products, in my particular case consumer durables, investigation of virtual prototypes of products is not enough. In the literature there appears to be agreement that a larger system should be taken into account with three main components: the human user, the product and the surrounding environment (Roozenburg, N.F.M. and Eekels, J., 1995). These components interact through mutual exchange and transformation of matter, energy and information. In this paper, the system will be referred to as the human-product-surroundings system, for short HPS system or HPSS. My assumption is that simulation of HPS systems can be a valuable addition to the currently available methods and tools to support designing for use, especially if it allows a designer to perform comprehensive investigation of both human aspects and system aspects.

Objectives and scope of the survey

This survey is part of the knowledge exploration for the development of a new computer-based simulation approach that can be applied in conceptual design to investigate use processes and predict the behavior of HPS systems. In the investigated literature, no existing approach that fulfills this purpose was found. Only a scattered collection of separate approaches partially covering the area of interest appears to be available. Ideally, an integrated approach should take advantage of the available scattered simulation knowledge. With that objective in mind, a comprehensive survey would have to cover approaches for the simulation of artifacts, artifactual systems, humans and human-artifact systems.

The paper covers the first part of what a comprehensive survey of simulation approaches for use processes would cover, and thus focuses on simulation approaches for artifacts and artifactual systems and on how they can be deployed to investigate operation

of the product and/or objects in the surroundings. The survey focused on research achievements published in scientific literature but relevant commercial solutions have also been included; these are referenced in footnotes. Priority was given to achievements and examples related to the use of consumer durables. Contributions from other fields have been included if no search results had been obtained from the focus area. The reader has to be aware that, as a consequence of the focus on artifact simulation, human-behavior simulation has explicitly been left out and therefore, the direct relevance to use processes will not be obvious in all cases. A successive survey that includes simulation of humans has been planned to complete the obtained results.

Assessment criteria

The various approaches to simulation will be assessed based on their potential contribution to investigation of use processes. The following criteria will be applied:

- *Range of behaviors covered.* A new tool for use-process simulations should cover as many types of artifact behavior as is reasonably possible. In the next subsection a scheme is introduced to classify the various behaviors.
- *Relevance of the scope.* The overlap between the scope of a simulation approach and the scope of the application area, use of consumer durables, should be as large as possible.
- *Ease of preparation.* The amount of time needed to set up a simulation should be kept at a minimum. Ideally, common artifact models created by designers are also simulation models. My assumption is that most designers of consumer durables use solid-modeling CAD packages. If these models cannot directly be used as a virtual prototype, a second-best option is that available CAD models can be *converted* to simulation models in an automated way.
- *Speed and computability.* The time needed for a simulation run on common hardware should be as short as possible.
- *Ease of interpretation.* Traditionally simulation output is numerical, e.g., tables or graphs show the course of values in time. My assumption is that, especially to designers, spatial 3D animation of the simulated system is a valuable addition to numerical output.
- *Fidelity of the outcomes.* The outcomes of the simulation must sufficiently correspond to real behavior.

- *Combination options and exchangeability of data.* Since no simulation approach covers all the aspects of use, it is worthwhile to consider if and how various simulation approaches can be combined to extend the scope.

Types of behavior in simulation

To classify the possible artifact behaviors a subdivision according to the common areas of physics can be applied: mechanical behavior, acoustic behavior, optical behavior, etc. (Figure 1). The effects of these behaviors can be observed as flows and transformations of energy and matter. Information exchange can also be simulated as an observable physical effect because it is based on signals encoded as energy or matter. However, as will be shown in the survey, certain simulation approaches disregard the physical background of information exchange. They operate on the interpretation of physical effects as information. It is for that reason that I will distinguish *interpreted physical behavior* as a special type of behavior alongside *observed physical behavior* (Figure 2). Observed physical behavior has subcategories¹ according to Figure 1, which can be simulated individually or simultaneously (i.e., *multiphysics*). Interpreted physical behavior substitutes observable physical behavior based on abstractions. For instance if voltages produced by a device represent either ‘0’

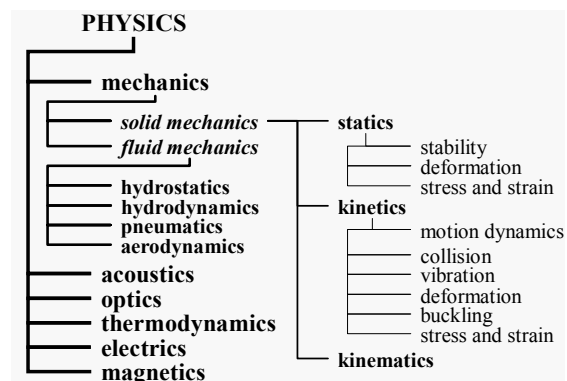

Figure 1 Taxonomy of the areas of physics

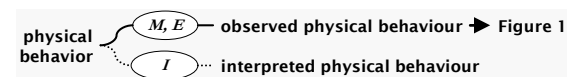

Figure 2 Subdivision of behavior types into observed and interpreted physical behavior

¹ For the assessment, statics is treated as a special case of kinetics for which resultant forces or torques are zero. The subdivisions of kinetics have been simplified to (i) *flexible-body* kinetics, covering stress, strain, (elastic) deformations and buckling, and (ii) *rigid-body* kinetics, covering the other sub-behaviors.

or '1', the output '100111' is the abstraction or interpretation of a series of output voltages. If a system is interpreted as purely informational, it is characterized as *discrete* and if it is investigated through its observed behavior it is said to be *continuous* (Bobrow, D.G., 1984). If it is investigated by observing *and* interpreting behaviors it is called hybrid (Zeigler, B.P. et al., 2000).

Structure of the survey

The discussion of the various approaches to simulation is structured based on the theoretical basis of the models that are used for simulation. Figure 3 gives the taxonomy of model types that I chose to use in his survey. At the highest level, behavioral models and object models are distinguished. These models represent the behavior of the artifact or the artifact itself, respectively. Behavioral models can be subdivided into control models and processing models, which represent the 'whys' and the 'hows' of simulated behaviors, respectively. Control models are logic-based or laws-based and processing models are algebraic, algorithm-based or animation-oriented. There are two types of object models: relationship models and entity models. Relationship models describe logical or spatial relations. Entity models can be abstract or concrete. Abstract entity models are based on 2D-graphics or 3D-schematics. Concrete entity models are typically boundary models, simplified boundary models, volumetric models or simplified volumetric models.

As the survey results will show, most simulations are based on combinations of model types. Therefore, the tree structure of Figure 3 cannot directly be used to organize the survey. However, it is possible to use the highest level, distinguishing models that concen-

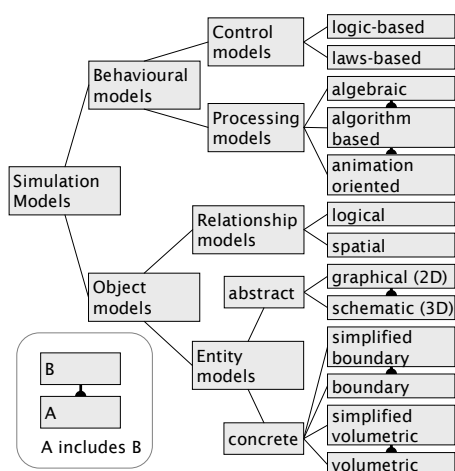

Figure 3 Taxonomy of model types used in simulation

trate on behavioral aspects and models that concentrate on object aspects, respectively: in section 2, artifact simulation approaches that concentrate on behavioral models are reviewed and in section 3 the approaches that concentrate on object models are reviewed. The discussion of the individual simulation approaches loosely follows the right-hand side of Figure 3 based on the key characteristics of each approach. Section 4 follows with the conclusions, which include a comparative overview of the analyzed approaches, and addresses which open issues remain and how they can be dealt with in future work.

2. SURVEY OF SIMULATION APPROACHES PRIMARILY BASED ON BEHAVIORAL MODELS

Behavioral models for simulation are virtual prototypes that represent artifact behaviors rather than artifacts. They are typically based on operational-logical descriptions, algebraic descriptions or algorithms. The algorithm-based behavioral simulations have been subdivided into algorithm-based quantitative simulation of continuous systems, algorithm-based qualitative simulation of continuous systems, algorithmic simulation of discrete systems based on finite state machines and algorithmic simulation of hybrid artificial systems.

Simulations based on operational-logical descriptions

Operational logic is a particular type of logic that describes the decomposition of a process into sub-processes. Operational-logical models are typically applied in business process modeling (Aguilar-Savén, R.S., 2004). Their application to artifacts mainly concerns enterprise information systems (e.g., Chen-Burger, Y.H. and Stader, J., 2003) and manufacturing systems (e.g., Cutkosky, M.R. and Tenenbaum, J.M., 1990). Simulations are limited to prediction of interpreted behavior in business processes, for instance, process lead times or conflicts in resource allocation. Since algorithms are commonly attached to the models in order to make such predictions possible (Poiaga, L., 2003) there is no sharp distinction between operational-logic based models with simulation capabilities and the finite state machines discussed later.

Simulations based on algebraic descriptions

In the algorithms that form the foundation for the simulation approaches discussed in the remaining

part of section 2 and throughout section 3, algebra is applied together with logic. This subsection deals with simulations purely based on algebraic descriptions, i.e., the simulation model does not contain instructions for algorithmic processing. In the conventional calculus-based approach to artifact simulation, sets of symbolic equations specify a particular situation or a class of situations to which laws of physics apply (Bryant, C.R. et al., 2001). Usually the artificial system, the situation and the involved laws are idealized to reduce computing time. The physical behavior is predicted by solving differential equations in the time domain. Many examples of application of this classical and widely accepted simulation approach to use processes are found in textbooks. For instance, in a textbook by Shigley, J.E. and Mischke, C.R. (1989) differential equations are solved to predict the time a clutch needs to stop a rotating shaft and to calculate the generated heat flow. In Meriam, J.L. and Kraige, L.G. (2003) numerous other examples from the subfields of solid mechanics can be found. An example from a different field is the simulation of aeroacoustic behavior of a vacuum-cleaner fan by Jeon, W.-H. et al. (2003).

Predicting behavior based on deriving and solving differential equations can be done completely manually. Computer support has been considered or is available for (i) deriving differential equations and boundary conditions based on given system descriptions, (ii) finding analytical solutions for given differential equations, (iii) solving differential equations numerically and (iv) calculating the values of system variables based on the time-dependent functions that form the solutions of the differential equations.

Computer support to derive differential equations is based on automated derivation from object models or on catalogs. The only approach for automated derivation from object models I found in the literature is the knowledge-based software introduced by Gelsey, A. (1991), which was able to derive differential equations for kinematical behavior directly from CAD models. I could not find references to further developments based on this approach. Catalog-based classification based on solution principles (i.e., subsystems that fulfill given functions) has been proposed, among others, by Roth, K., (1982). In these approaches, the computer merely offers the designer a database with equations to choose from but it does not solve them.

To solve differential equations analytically, commercial software based on symbolic manipulation can be

used, e.g., Maple (Baldwin, D. et al., 2004). To solve differential equations numerically, for instance if no analytical solution exists, several methods have been developed, e.g., Newton-Raphson and Runge-Kutta (Riley, K.F. et al., 1997), which have been included in commercial mathematics software such as Maple, Mathematica and MATLAB². These packages are also able to calculate the course of system variables based on derived solutions of differential equations. The simulation output is typically numerical.

Algorithm-based quantitative simulation of continuous systems

In general, algorithms combine algebraic expressions with formal procedural logic describing the process of computation, i.e., calculating values of simulation parameters and evaluating conditions that determine which algebraic expression is valid. Algorithms are usually formally defined by using a programming language such as C++ or SIMULA (Joines, J.A., & Roberts, S.D., 1998), a specification language such as XML or UML (Pllana, S. and Fahringer, T., 2002), or a combination thereof (Pop, A. et al., 2005).

Adding logic to algebraic descriptions makes it possible to deal with behavioral laws that introduce discontinuities in the course of a process. This is the case when conditions determine which physics laws are involved. A change in the set of involved laws causes a transition in the behavior, for instance when objects collide in 3D space. Baraff, D. (1994) introduces an algorithm for fast computation of collision behavior of rigid bodies. Hummel, A. and Girod, B. (1997) present an algorithm that is used for elastic flexible bodies. These purely algorithm-based approaches do not offer support for conversion from CAD files and they typically produce numerical simulation output.

Algorithm-based qualitative and semi-quantitative simulation of continuous systems

Qualitative simulation is based on the theories of qualitative reasoning, qualitative physics and qualitative process theory (Bobrow, D.G., 1984), (Forbus, K.D., 1984). It has been developed for the investigation of incomplete system models, predicting behavior based on qualitative differential equations (QDES). A QDE is an abstraction of an ordinary differential equation. It is qualitative because (i) it describes the values of variables ordinally (e.g. low – medium – high) rather than in numbers and (ii) relations between variables are described as monotonic functions

² maplesoft.com, wolfram.com, mathworks.com

(e.g. y decreases if t increases) rather than algebraic functions. These descriptions can be augmented with semi-quantitative bounding intervals (Kuipers, B.J., 2001). Just like quantitative differential equations, QDES typically have to be drafted manually, and similarly, catalogs have been proposed to provide predefined QDES for system components (De Kleer, J. & Brown, J.S., 1984). It is also possible to derive qualitative simulation models automatically from object models, in particular based on bond graphs (see section 3) (Xia, S. et al., 1993) but from what I could find in the literature, not from CAD models.

Visualizing the output of qualitative simulations is difficult because of its qualitative nature. Figure 4 shows an example. Another drawback of qualitative simulation is that for complex systems the simulation frequently is intractable or results in a large, incomprehensible behavioral description (Clancy, D.J. and Kuipers, B.J., 1994). Nevertheless, qualitative simulations have been applied to a wide range of physical phenomena appearing in artifacts. Kramer, G.A. et al. (1989) patented a method for qualitative simulation of kinematics in linkages. Bozzo, L.M. et al. (1998) apply it to predict deformations in flexible beams. Sokolsky, O. and Hong, H.S. (1987) describe a qualitative hybrid simulation of a control system for the water level in swimming pools.

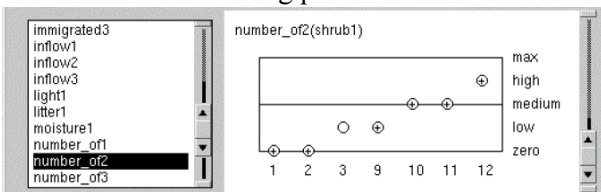

Figure 5 Output of qualitative simulation of vegetation growth with the simulation package VisiGARP (Bouwer, A. and Bredeweg, B., 2001)

Algorithmic simulation of discrete systems based on finite state machines

Finite state machines (FSMs) are mathematical constructs to describe behavior of discrete systems, thus fulfilling the same role as ordinary differential equations for continuous systems (Branicky, M.S., 1995). System behavior is discretely defined as states, each of which describes the system for an interval of time. A transition between states occurs if the FSM receives specified input (Khoussianov, B. and Nerode, A., 2001). Output can also be assigned to transitions or states (Lee, D.-T., 2002). In physical artifacts, digital circuits and embedded software are the typical discrete subsystems for which FSMs are used. The input corresponds to signals these subsystems receive from

sensor components and the output to signals they transmit to actuator components (Thompson, M.T. and Heimdahl, M.P.E., 1999).

For modeling FSMs several formalisms have been developed, most of which are visually enhanced, typically based on directed graphs (Phillips, C.H.E., 1994). I will discuss three formalisms that are used for modeling and simulation of use processes: (i) state transition diagrams, (ii) Petri nets and (iii) statecharts. *State transition diagrams* (STDs) are basic graphical representations with states connected by transitions labeled with input-output pairs (Gill, A., 1962). In a *Petri net*, a representation introduced in 1960 by Petri (Petri, C.A., 1996), states are depicted as combinations of places populated with tokens that can migrate through transitions. The distribution of tokens over the net denotes the state of the system (Heitmeyer, C. & Mandrioli, D., 1996). The distinction between states and places makes it possible to model concurrency. *Statecharts* have been introduced by Harel in the 1980s to support concurrency, hierarchy in processes and communication between sub-processes. The statechart representation is claimed to be compact despite the enhanced expressiveness (Harel, D., 1987).

Use processes are one of the application areas of FSMs. In some cases, they are used for computer-based simulation of the discrete artifact behavior with input from human subjects ('human-in-the-loop' simulations): Martel, A. (1998) uses an STD to simulate the user interface of a microwave oven. Chris-

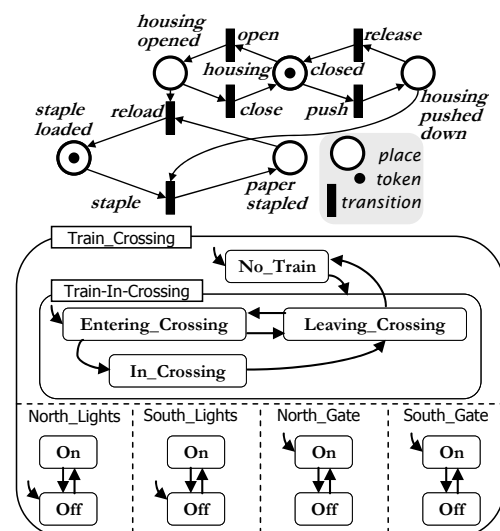

Figure 4 a (top): Petri-net (adapted from Koga & Aoyama, b (bottom): Statechart (adapted from Thompson & Heimdahl): boxes denote states, arrows denote transitions and dashed lines separate concurrent sub-processes.

tensen, S. et al. (1997) use a Petri net to simulate a linking device for networked audiovisual equipment. Thompson, M.T. and Heimdahl, M.P.E. (1999) simulate a railway crossing based on a statechart (Figure 5b). In other cases, models are used in the requirements phase of design, as an extended function description. In this particular application of FSMs, the model includes continuous behavior but only as a linguistic description. Koga, T. and Aoyama, K. (2004), for instance, use a Petri net to define the intended use of a stapler (Figure 5a).

Various software packages exist for modeling and simulation of STDs (Koznov, D.V. et al., 2004), Petri nets³ and statecharts⁴. Inputs and outputs of some of these systems can be connected to physical continuous systems or to human interfaces. For physical artifacts with continuous behavior (like the stapler in Figure 5a), I could not find forms of computer support to derive FSMs from artifact models. For discrete (sub)systems however, it is possible to create hardware designs and even fully functional (embedded) software automatically from an FSM (Drusinsky, D. and Harel, D., 1989), (Yakovlev, A.V. et al. 1996), so that FSM modeling replaces artifact modeling in the design process without any need to convert (other) artifact models to FSMs.

Hybrid algorithmic simulation of artifactual systems

In hybrid systems, continuous and discrete behaviors are investigated together, for instance in products in which digital circuits and physical components operate together. A widely used formalism for modeling and simulation of such systems is the ‘discrete event and differential equation system specification’ (DEV&DEVS) proposed by Zeigler, B.P. et al. (2000). It is used to create system models in which the discrete-event behavior is modeled using an FSM called DEVS diagram, and the continuous behavior is modeled algebraically using dedicated differential equations (e.g., Nutaro, J., 2006). Praehofer, H., and Pree, D. (1993) use DEV&DEVS to simulate the behavior of an electric kettle: the switching of the thermostat and the level sensor are simulated discretely, while temperature and level variations are simulated continuously.

Since DEV&DEVS requires dedicated differential equations for continuous behaviors, manual preparation of the behavioral model is needed. The same

options for additional computer support as discussed earlier for quantitative simulation of continuous systems are available to facilitate the job.

3. SIMULATION APPROACHES PRIMARILY BASED ON OBJECT MODELS

This category of simulations uses models that represent artifacts in the first place. Some models include behavioral elements, but these are not visualized. Models are typically based on block diagrams, bond graphs, abstract entity models representing 3D schematics, rigid 3D volumetric models, mesh models and meshless models.

Simulations based on block-diagram and bond graph models

Block-diagrams and bond graphs are abstract 2D graphical entity models, with logical relations defining physical connections. Block diagrams are built up from predefined blocks that algorithmically represent physical laws determining the behavior of components such as resistors, amplifiers, etc., including components that perform interpreted physical behavior (Karayanakis, N.M., 1995). Together with the relations, behavior descriptions of components form an algorithm for simulation of the behavior of the system. Behavior descriptions do not have to be entity-related, thus it is also possible to create behavioral models with block diagrams. The diagrams are mostly used to model and simulate signal-processing and control systems, for instance servo mechanisms in consumer durables (e.g., Shieh, M.-Y., & Li, T.-H

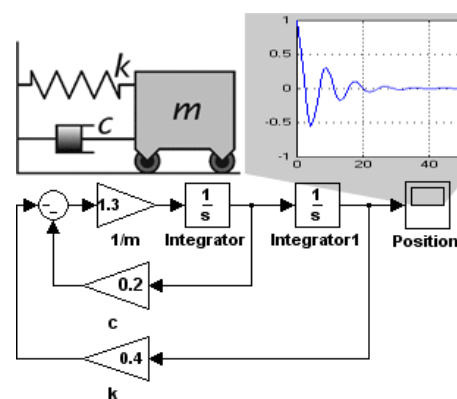

Figure 6 Block diagram⁵ (bottom) of a mass-spring-damper system (top left) created in SIMULINK with a graphical plot of the simulated position as a function of time (top right)

³ informatik.uni-hamburg.de/TGI/PetriNets

⁴ e.g., Simulink Stateflow (mathworks.com)

⁵adapted from Stanciu, tinyurl.com/79fza

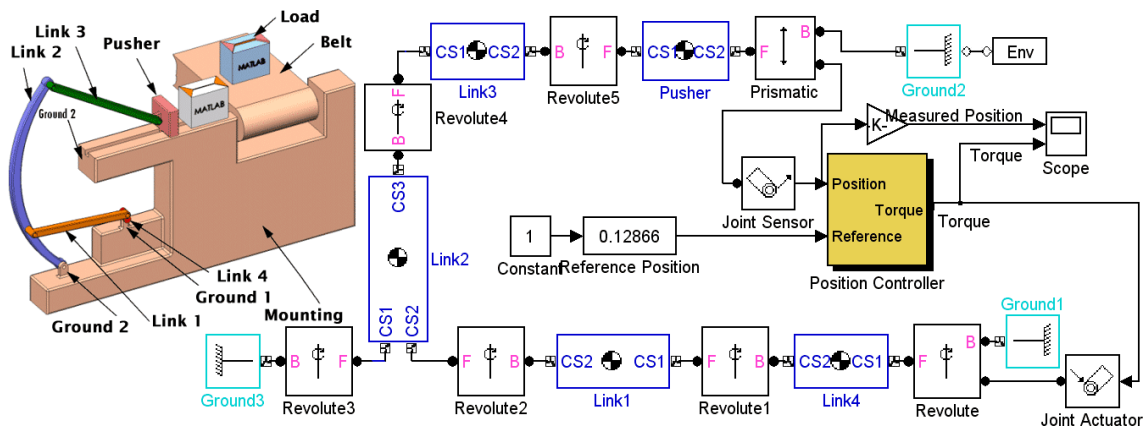

Figure 7 SimMechanics model of the conveyor loader depicted on the left. The ‘Position Controller’ is a servo mechanism modeled separately as a conventional block diagram. (Demo provided with the software).

1998), but block-diagram based simulations are also applied to mechanical systems (Świder, J. and Wszolek, G., 2004). Figure 6 shows a simple example. Several commercial software tools are used to create and simulate block diagrams. Examples for general use are ACSL, SIMULINK and VisSim (Karanayakis, N.M., 1995). In conventional block diagrams, the relationships between blocks are defined as a unidirectional energy flow, which defines a procedural input-output treatment for the simulation computation. A disadvantage of this approach is that, although the diagram represents the object, there is no visual resemblance (Fishwick, P.A., 1995), as is illustrated in Figure 6. Feretti, G. al (2004) claim that, additionally, the flow through the blocks does not conform to our reasoning about observed physical behavior. They suggest adopting a block modeling approach based on declarative rather than procedural relations, as is done in the commercial package Dymola⁶. The result is a block diagram without causal arrows, in which the blocks have the same connections as the components they represent. This is also true for SimMechanics⁷, a mechanical block-diagram modeling environment for SIMULINK, as is demonstrated in Figure 7. However, despite the visual improvement over conventional block diagrams, the representation is still rather abstract.

Both Dymola and SimMechanics offer the possibility to import components automatically from SolidWorks CAD files. Joints, masses, moments of inertia are translated, but some variables, such as spring and damper constants have to be entered manually. The geometry information that determines the visual ap-

pearance of the artifact is lost. The standard output of block-diagram simulations is numerical. Dymola and SimMechanics can link the output to a 3D animation of a CAD model, but the procedure is labor-intensive.

Bond-graph based simulations have been introduced as an alternative to block diagrams by Paynter in the 1950s (Paynter, H.M., 1961). They can be converted to block diagrams. Simulation is based on energy flows between elements representing components with basic physical characteristics (Finger, S. et al., 2001). Analogies between different domains of physics allow for using the same building blocks for mechanical, electrical, hydraulic, etc. components and perform multiphysics simulations (Fishwick, P.A., 1995). As the connecting ports have been defined, they correspond to physical connections in electrical and hydraulic systems (Thoma, J. and Halin, H.J., 1999). However, in the mechanical realm they do not: Figure 8 illustrates the counterintuitive arrange-

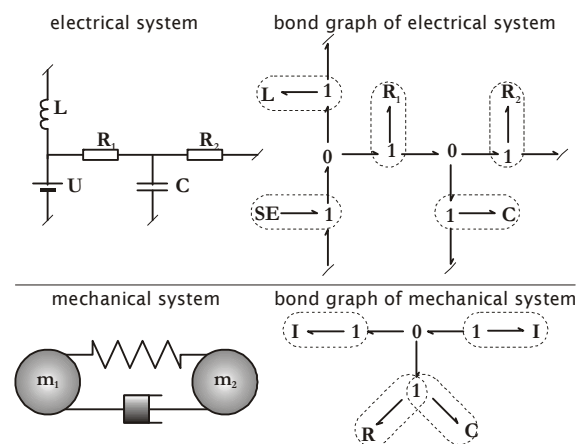

Figure 8 Bond graph models. Top: adapted from Webster, P.M, (1994). Bottom: adapted from Stramigioli, S. (1998).

⁶dynasim.se

⁷From the available information (mathworks.com) it is not clear whether SimMechanics is based on a declarative approach.

ment of blocks in mechanical systems. Another drawback of bond graphs is that they have been developed with discrete-component systems in mind (Yen, C. and Masada, G.Y., 1991). To study behaviors of a continuum, such as deformations in an object, it must be discretized. Yen and Masada apply this as the ‘extended bond graph method’, to simulate vibration in hyperelastic thin plates. In a comparison, however, they found that the validity of results obtained with the finite-element approach (see section 3) is better. Use of consumer durables is one of the areas where bond graphs have been applied. For example, Remmerswaal, J.A.M. and Pacejka, H. (1985) used bond graphs to simulate forces during the handling of a vacuum cleaner.

Various software packages are available to create and simulate bond graph models. None of the packages reviewed by Montbrun-Di Filippo, J. et al. (1991) and by Samantaray⁸ in 2001 appears to offer automatic conversion from or to CAD models. Thus, creating bond graph models requires additional modeling efforts. The standard output of bond graph simulations is numerical.

Simulation approaches based on abstract entity models representing 3D schematics

Abstract entity models representing 3D schematics use graphical elements that include part of the geometry of the object. We distinguish rigid 3D line models and skeleton-like models. Rigid 3D line models consist of connected edges (rods) and nodes arranged in 3D space. The nodes define joints and their degrees of freedom to enable kinematical simulation of linkages (e.g., McCarthy, J.M., 2000). I will not further discuss these models here, since they offer a subset of the functionality of rigid volumetric models (see next subsection) without apparent advantages.

Skeleton-like models represent the geometry of objects by dimensionally reducing them to forms without interior (Rusák, Z., 2003). Compared to line models, skeleton-like models extend the functionality of the nodes to areas of physics outside the mechanical domain, even offering the possibility of multiphysics simulation. The modeling elements contain knowledge about behavioral laws. Skeleton-like models can be considered an alternative to block diagrams and bond graphs that allows a more intuitive arrangement of mechanical components, and additionally, visualization of the main geometry. An ex-

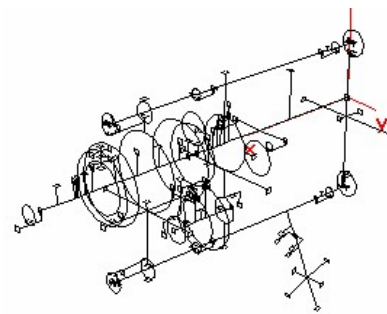

Figure 9 Skeleton-like model of a hand drill

ample of a modeling and simulation system based on skeleton-like models is PREDES (Horváth, I. et al., 1995). Figure 9 shows a skeleton-like model of a hand drill created with PREDES. Partial automatic conversion of CAD models to the PREDES environment is possible, but conversion results are not unique. The system has not been developed to a version that can provide output in the form of animations.

Simulation approaches based on rigid 3D volumetric models

Simulation approaches for rigid 3D volumetric models have been developed for kinematical and rigid-body kinetic behavior. Kinematical simulation is included in the assembly modules of most of the commercial solid-modeling systems (Lee, K., 1999). Dedicated packages such as MSC VisualNastran4D (Figure 10) and CosmosMotion⁹ can perform kinematical simulation and rigid-body kinetic simulation. Flexible-body kinetics is limited to discrete components (springs, dampers)¹⁰. Knowledge about behavioral laws is not included in the virtual proto-

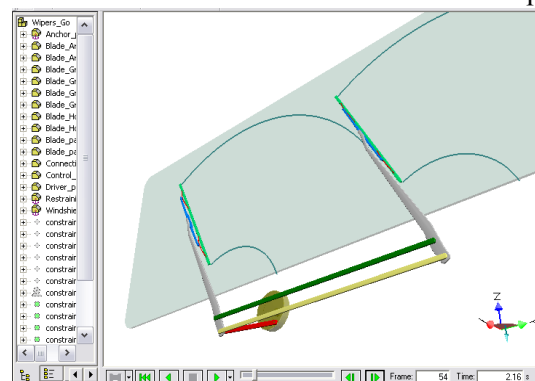

Figure 10 Simulation model of windscreen wipers in MSC VisualNastran 4D (demo provided with the software)

⁸bondgraphs.com/software.html

⁹ mcssoftware.com; solidworks.com

¹⁰ Recent versions of VisualNastran offer analysis of heat flow and stress and strain based on finite elements.

type but in a separate simulation algorithm. Current tools seem to be in the mature stage with no further developments pending (Wang, S.-L., 2001).

An advantage of volumetric-model based simulation is that it can be seamlessly integrated with conventional solid-modeling tools for product design. The output can typically be shown as an animation of the object model.

Simulation approaches based on mesh models

A mesh in 3D is a simplified volumetric representation created by discretizing a geometric domain into small simple shapes. Typically these are polygons, such as tetrahedra and hexahedra (Bern, M. and Plassmann, P., 2000). Several mesh-based approaches exist, such as the finite-element, boundary-

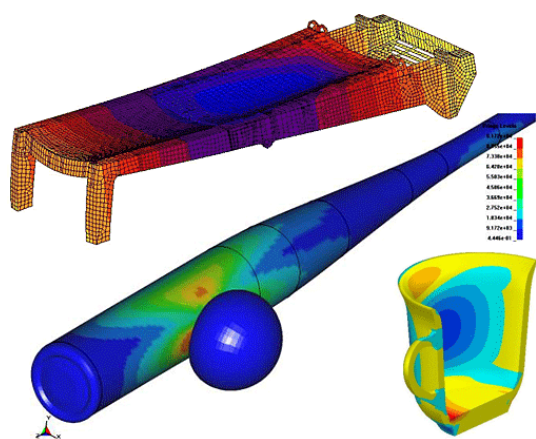

Figure 11 FE-based simulation of consumer durables. Top-down: stress distribution in a lounge chair; deformations in a ball and bat; stress distribution in a teacup¹¹.

element, finite-difference and finite-volume approaches. To keep the survey concise I will only discuss the finite-element (FE) approach, which is the most widely used (Zeid, I., 1991). The FE approach is based on laws that assume energy minimization in the object and on interpolation functions that are applied on the mesh. Knowledge of the behavioral laws is not included in the object model itself. The FE approach was originally intended for static stress analysis (Zienkiewicz, O.C. and Hollister, G.S., 1965). Later extensions cover dynamic mechanical behavior, heat conduction, electric and magnetic potential and hydrodynamics (Zienkiewicz, O.C. and Taylor, R.L., 2000), as well as acoustics (Tsuchiya, T. et al., 2003) and optics (Fikri, R. et al., 2003). However, I could not find publications reporting on the use of

¹¹sources: bpo (bpo.nl); predictive engineering, (predictiveengineering.com); visual FEA, (visualfea.com)

FE-based simulation in kinematics. The FE approach is often used to simulate product behaviors. Friswell, M.I. et al (1996) simulated vibrations in golf clubs. Middendorf, W.H. (1990) investigated mechanical stress in a motorcycle suspension fork and magnetic fields in the rotor of an electric motor. Figure 11 shows three more examples from commercial practice.

Commercial FE software packages are, among others, MSC Nastran (Komzisk, L. and Stanton, E., 2000), Algor, Visual FEA and Comsol¹². A promising advancement is the increasing support of multiphysics (Bailey, C. et al., 1998), which most of the commercial software packages claim to offer. Mahoney, D.P. (2000) reviewed the multiphysics capabilities of FemLab (currently known as Comsol), Ansys and Algor. Real-time dynamic simulation is still a challenge for these packages. Only FemLab supports it but the user has to define the model up to the level of dedicated partial differential equations. Ansys and Algor can only perform multiphysics simulation iteratively, switching back and forth between different phenomena until the solution has converged suffi-

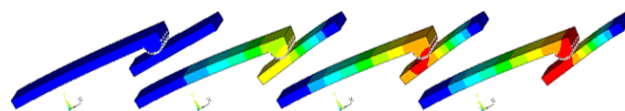

Figure 12 Multiphysics simulation of a switch.

ciently. Figure 12 shows a simulation of mechanical deformation, electric current and heat flow with Ansys Multiphysics. The animation frames show the changes in shape and temperature distribution. Note that the simulated model is actually 2D.

Mesh-based simulations of physical behavior can be performed based on shape models created with CAD systems, but these must be pre-processed using a meshing algorithm which is typically included in the simulation software. Modifications have to be performed on the CAD model, which must then be re-meshed before a new simulation. All the abovementioned commercial tools offer output in the form of animations.

Simulation approaches based on meshless models

Discretization of meshless models is not based on polygons, but either on (i) dimensionless particles populating the geometric domain or (ii) subdivision of the functional space underlying the geometric do-

¹² mscsoftware.com, algor.com, comsol.com.

main. Both approaches have two advantages over mesh-based approaches (Li, S. & Liu, W.K., 2002) (Tsukanov, I. and Shapiro, V., 2002). First, extreme deformation and even fracture of objects can be simulated without the need for re-discretization on the fly. Secondly, the number of computation-intensive preparation steps to create simulation models from CAD is reduced.

The particles in particle-based simulation are typically connected by springs and dampers in solid mechanics and by implicit surfaces in fluid mechanics. In solid mechanics, the approach is applied in the simulation of deformable objects, including viscoelasticity, plasticity and fracture (Terzopoulos, D. & Fleischer, K., 1988), where its advantage lies in producing realistic animations in real time. Mechanical applications include collision of deformable bodies (Jansson, J. and Vergeest, J.S.M. 2002), anisotropic material behavior (Bourguignon, D. and Cani, M.-P., 2000) and rigid-body dynamics (McDonald, J., 2001). The fluid-mechanics applications I found in the literature focus on the entertainment industry, where realistic visual appearance is more important than validity of the outcomes (Foster, N. and Fedkiw, R., 2001). In that application area, the main challenge is to generate a visually realistic surface representation based on the particle distribution (Premoze S. et al., 2003).

The two main approaches for decomposition of the functional space are meshfree Galerkin methods and Rvachev's function method. These methods have the abovementioned two advantages of particle-based methods while offering the possibility of non-mechanical, even multiphysics-type of simulations. Details on the methods can be found in (Li, S. and Liu, W.K., 2002) and (Tsukanov, I. and Shapiro, V. 2002). Based on Rvachev's function method, the commercial software package FieldMagic¹³ has been developed. From the available examples it appears that currently, multiphysics simulations are still limited to the investigation of two concurrent phenomena in a system that is typically reduced to a simple 2D model. Disadvantages of meshless compared to mesh-based approaches are that simulation is more computation-intensive and that it is more difficult to define boundary conditions in the model (Meiling, Z. et al., 2004).

¹³sal-cnc.me.wisc.edu/Research/meshless/meshfree.php

4. CONCLUSIONS AND FUTURE WORK

In the preceding subsections a variety of artifact simulation approaches has been discussed. The suitability for use-process modeling and simulation is intrinsically limited because the behavior of humans is not covered. Thus, by necessity, the following assessment according to the criteria listed in the introduction is limited to what simulation approaches can contribute to the prediction of artifact behavior in use processes:

- *Range of behaviors covered.* Table 1 gives an overview of the types of behavior covered by the analyzed simulation approaches. Some of the behavioral models appear to be the most versatile. Ease Interpreted physical behavior is poorly supported by the simulation approaches that focus on object models. In this group, the skeleton-based approach, which does not seem to be adopted by commercial software, appears to be the most versatile. Most of the discretized-model based approaches lack support of kinematics, and offer multiphysics support only for simple models.
- *Relevance of the scope.* In particular, the approaches based on graphical entity models (block diagrams and bond graphs) focus on simulating the behavior of systems built up from discrete components, e.g., in mechatronics. Simulating physical effects in continua, which is often important in the use of consumer durables (for example, deformations in furniture), is difficult using these approaches. Furthermore, the scope of approaches based on operational-logical descriptions appears to have little overlap with my area of interest.
- *Ease of preparation.* According to Table 1, the approaches based on 3D object models require the least preparation effort because they offer automatic conversion from CAD models. A disadvantage is still that non-geometry related physical properties (e.g., thermal conductivity, or Young's modulus) are absent in CAD models and have to be entered during the simulation preparation. Also, the automated preprocessing needed for the discretized model-based approaches (e.g., meshing and re-meshing) is computation-intensive and thus time consuming. It must be noted that judging the ease of preparation based only on compatibility with CAD models is unfair to approaches specialized in simulation of interpreted physical behavior. Especially FSMS appear to be attractive for simulation of discrete subsystems, such as digital circuits and embedded software in products, because (i) the visual representation of FSMS

Table 1 Comparison of artifact-simulation approaches

Simulation approaches		Criteria												
		Range of behaviors covered												
Type of model on which the approach is based		rigid-body kinetics	elastic flexible-body kinetics	kinematics	fluid mechanics	acoustics	optics	thermodynamics	electricity	magnetism	multiphysics support	interpreted physical behavior	ease of preparation (a)	ease of interpretation (b)
behavioral	Operational-logical descriptions										N/A	i	-	-
	Algebraic descriptions										± g		-	-
	Quantitative algorithms										± g		-	-
	Qualitative algorithms										± g		-	-
	Finite state machines										N/A		-	-
	Algorithms for hybrid systems										± g		-	-
object-representing	Conventional block diagrams	c	c	c	c	c	c	c	c	c	+	c	-	-
	Dymola, SimMechanics	c	c	c	cd	cd	cd	cd	cd	cd	± d	cd	±	-
	Bond graphs	cf	cf	cf	cf	cf	cf	cf	cf	cf	+	cef	-	-
	3D line models		c								-		±	+
	Skeleton-like models										+		+	-
	Rigid 3D volumetric models		c								-		+	+
	Mesh-based models										± h		+	+
	Particle-based models										± h		+	+
	Subdivision of functional space										± h		+	+

supported
 supported with limitations (see notes)
 unsupported

+ high
 ± medium
 - low

Notes:

- a (-) very limited or no automated conversion from CAD models; (±) automated conversion of specific variables from CAD models; (+) automated conversion of geometry from CAD models
- b (-) no animation of object model provided (or only possible through manual linking); (+) animation of object model provided
- c modeling limited to systems built up from discrete components
- d modeling and simulation of non-mechanical behavior supported only by Dymola (in SimMechanics, conventional block-diagram elements need to be added).
- e by including conventional block-diagram elements
- f static behavior not supported
- g complexity of equations/algorithms is limited from a practical viewpoint
- h limited to simple models due to computational complexity
- i limited predictive capabilities

seems easy to understand for designers who have no background in digital system engineering (ii) the models can be used to create functional hardware and software automatically.

- *Speed and computability.* This criterion could not be evaluated. The literature sources report on simulations of different artifacts of varying complexity. Also, some approaches are still under development while others have matured and are commercially available. These two factors make it difficult to compare the performance.
- *Ease of interpretation.* The overview in Table 1 shows that the various approaches based on 3D object models can directly produce animations of simulated behavior. The output of most of the other approaches can also be connected to 3D representations to provide animations, but this requires manual efforts.
- *Fidelity of the outcomes.* As is the case with the speed and computability, it is hard to judge this criterion based on what I found in the literature. Only the particle-based approaches for fluid-mechanics need to be treated with particular care because their intended application area is the entertainment industry, and not product design.
- *Combination options and exchangeability of data.* This criterion is especially important for the integration of artifact simulation and human simula-

tions. Assessment is expected to be possible based on a forthcoming survey of human-simulation approaches. Within the context of artifact simulation, Table 1 suggests that simulation of 3D representations together with the simulation of interpreted physical behavior form an interesting combination that is worth exploring. None of the approaches I encountered in the literature covers this area, which is especially interesting because consumer durables increasingly combine functionality based on observed physical phenomena with electronics and software (Bürdek, 1994). Available approaches for hybrid simulation of such products are preparation-intensive (e.g., DEV&DEVS), they do not support conversion from CAD and do not provide visualized 3D simulation output.

Interpreting these evaluation results, it can be said that among the current artifact-simulation approaches the various discretization-based approaches appear to offer product designers the most advantages. However, there are drawbacks to be dealt with, the most important two being that (i) they do not offer simulation of interpreted physical behavior, and (ii) preparation of models for simulation is computation-intensive and requires manual input of non-geometric physical properties. Resolving these issues is an interesting direction for future work. An option for

adding interpreted-behavior simulation is to use the input/output options offered by FSM simulators, which are already used for human-in-the-loop simulations and real-time control of physical systems. The second issue can not only be interpreted as a problem of the discretized simulation approaches, but, alternatively, also as a problem of CAD systems failing to produce models that can be directly simulated. A possible solution is a dedicated CAD system that supports working on discretized models directly including non-geometric physical properties in models.

REFERENCES

- Aguilar-Savén, R.S., 2004, "Business process modelling: review and framework"; *International Journal of Production Economics*, Vol. 90, pp. 129-149.
- Bailey, C., Taylor, G.A., Cross, M., Chow, P., 1999, "Discretisation procedures for multi-physics phenomena"; *Journal of Computational and Applied Mathematics* 103, pp. 3017.
- Baldwin, D., Göktas, Ü., Hereman, W., Hong, L., Martino, R.S., Miller, J.C., 2004, "Symbolic computation of exact solutions expressible in hyperbolic and elliptic functions for nonlinear PDEs"; *Journal of Symbolic Computation*, Vol. 37, pp. 669-705.
- Baraff, D., 1994, "Fast contact force computation for non-penetrating rigid bodies"; *Proceedings of the ACM SIGGRAPH*, Orlando FL.
- Bern, M., Plassmann, P., 2000, "Mesh Generation"; In: Sack, J., Urrutia, J. (Eds.), *Handbook of Computational Geometry*. North Holland, New York.
- Bobrow, D.G., 1984, "Qualitative reasoning about physical systems: an introduction"; *Artificial Intelligence*, Vol. 24, pp.1-5.
- Bourguignon, D., Cani, M.-P., 2000, "Controlling anisotropy in mass-spring systems"; *Proceedings of Eurographics workshop, on computer animation and simulation*, pp. 113-123.
- Bouwer, A., Bredeweg, B., 2001, "VisiGarp: graphical representation of qualitative simulation models"; *Proceedings of the International Qualitative Reasoning Workshop*.
- Bozzo, L.M., Barbat, A., Torres, Ll., 1998, "Application of qualitative reasoning in engineering"; *Applied Artificial Intelligence*, Vol. 12, pp. 29-48.
- Branicky, M.S., 1995, "Universal computation and other capabilities of hybrid and continuous dynamical systems"; *Theoretical Computer Science*, Vol. 138, pp. 67-100.
- Bryant, C.R., Kurfman, M.A., Stone, R.B., McAdams, D.A., 2001, "Creating equation handbooks to model design performance parameters"; *Proceedings of ICED*, Glasgow, pp. 501-508.
- Bürdek, B.E., 1994, "Design - Geschichte, Theorie und Praxis der Produktgestaltung"; *DuMont Buchverlag*, Cologne.
- Chen-Burger, Y.-H., Stader, J., 2003, "formal support for adaptive workflow systems in a distributed environment "; In: Fischer, L. (Ed.), *Workflow Handbook 2003*. Future Strategies, Inc., Lighthouse Point, FL.
- Christensen, S., Jørgensen, J.B., Madsen, K.H., 1997, "Design as interaction with computer based materials"; *Proceedings of ACM-DIS 1997*, pp. 65-71.
- Clancy, D.J., Kuipers, B.J., 1994, "Model decomposition and simulation"; *Proceedings of the International Qualitative Reasoning Workshop*.
- Cutkosky, M.R., Tenenbaum, J.M., 1990, "A methodology and computational framework for concurrent product and process design"; *Mechanism and Machine Theory*, Vol. 25, No. 3, pp. 365-381.
- De Kleer. J., Brown, J.S., 1984, "A qualitative physics based on confluences"; *Artificial Intelligence*, Vol. 24, pp.87-83.
- Drusinsky, D., Harel, D., 1989, "Using statecharts for hardware description and synthesis"; *IEEE Transactions on Computer-Aided Design*, Vol. 8, No. 7, pp. 798-807.
- Eggert, R.J., 2005, "Engineering Design"; *Pearson Prentice-Hall*, Upper Saddle River.
- Ferretti, G., Magnani, GA., Rocco, P., 2004, "Virtual prototyping of mechatronic systems"; *Annual Reviews in Control*, Vol. 28, pp. 193-206.
- Fikri, R., Barchiesi, D., H'Dhili, F., Bachelot, R., Vial, A., Royer, P., 2003, "Modeling recent experiments of apertureless near-field optical microscopy using 2D finite element method"; *Optics Communications*, Vol. 221, pp. 13-22.
- Finger, S., Chan, X., Lan, R., Cahn, B., 2001, "Creating virtual prototypes - integrating design and simulation"; *Proceedings of ICED*, Glasgow, pp. 485-492.
- Fishwick, P.A., 1995, "Simulation model design and execution: building digital worlds"; *Prentice-Hall, Inc.*, Englewood Cliffs.
- Forbus, K.D., 1984, "Qualitative Process Theory"; *Artificial Intelligence*, Vol. 24, pp.85-168.
- Foster, N., Fedkiw, R., 2001, "Practical animation of liquids"; *Proceedings of the ACM SIGGRAPH 2001*, Los Angeles, CA, pp. 23-30.
- Friswell, M.I., Smart, M.G., Hamblyn, S.M., 1996, "The validation and updating of dynamic models of golf clubs"; *Proceedings of the International Conference on*

the Engineering of Sport, Sheffield.

- Gelsey, A., 1991, "From CAD/CAM to simulation: automatic model generation for mechanical devices"; In: Fishwick, P.A., Modjeski, R.B. (Eds.), Knowledge-based simulation - methodology and application. Springer, New York, pp. 108-132 .
- Gill, A., 1962, "Introduction to the theory of finite-state machines"; McGraw-Hill book company, Inc., New York.
- Harel, D., 1987, "Statecharts: a visual formalism for complex systems"; Science of Computer Programming, Vol. 8, pp. 231-274.
- Heitmeyer, C., Mandrioli, D., 1996, "Formal methods for real-time computing: an overview"; John Wiley & Sons, Chichester.
- Horváth, I., Thernesz, V., Bagoly, Z., 1995, "Conceptual design with functionally and morphologically parameterized feature objects"; Proceedings of ASME-CIE.
- Hummel, A., Girod, B., 1997, "Fast dynamic simulation of flexible and rigid bodies with kinematic constraints"; Proceedings of ACM VRST 1997.
- Jansson, J., Vergeest, J.S.M., 2002, "A discrete mechanics model for deformable bodies"; Computer-Aided Design, Vol. 34, pp. 913-928.
- Jeon, W.-H., Baek, S.-J., Kim, C.-J., 2003, "Analysis of the aeroacoustic characteristics of the centrifugal fan in a vacuum cleaner"; Journal of Sound and Vibration, Vol. 268, No. 5, pp. 1025-1035.
- Joines, J.A., Roberts, S.D., 1998, "Fundamentals of object-oriented simulation"; Proceedings of the 1998 Winter Simulation Conference, pp. 141-149.
- Karayanakis, N.M., 1995, "Advanced system modelling and simulation with block diagram languages"; CRC Press, Boca Raton.
- Khoussianov, B., Nerode, A., 2001, "Automata theory and its applications"; Birkhäuser, Boston.
- Koga, T., Aoyama, K., 2004, "Product behavior and topological structure design system by step-by-step decomposition"; Proceedings of ASME-DETC, Salt Lake City UT.
- Komzsik, L., Stanton, E., 2000, "Trends in analysis and optimization of products"; Proceedings of TMCE, Delft, pp. 19-27.
- Korn, G.A., Wait, J.V., 1978, "Digital continuous system simulation"; Prentice-Hall, Inc., Englewood Cliffs.
- Koznov, D.V., Kartashev, M., Gagarsky, R., Zvereva, V., Barsov, A., 2004, "Roundtrip engineering of reactive systems"; Proceedings of ISO/IA, Paphos, Cyprus, pp. 343-347.
- Kramer, G.A., Barrow, H.G., Agre, P.E., 1989, "Closed-form kinematics"; United States Patent No. 5,043,929.
- Kuipers, B.J., 2001, "Qualitative simulation"; In: Meyers, A. (Ed.), Encyclopedia of Physical Science and Technology, 3rd edition, pp. 287-300. Academic Press, New York.
- Lee, D.-T., 2002, "Evaluating real-time software specification languages"; Computer Standards & Interfaces, Vol. 24, pp. 395-409.
- Lee, K., 1999, "Principles of CAD / CAM / CAE systems"; Addison Wesley, Reading MA.
- Li, S., Liu, W.K., 2002, "Meshfree and particle methods and their applications"; Applied Mechanics Reviews, Vol. 55, No. 1, pp. 1-26.
- Mahoney, D.P., 2000, "Multiphysics analysis"; Computer Graphics World, 23 (6), pp. 44-46, 50, 52.
- Martel, A., 1998, "Application of ergonomics and consumer feedback to product design at Whirlpool"; In: Stanton, N.A., Young, M.S. (Eds.), Human factors in consumer products, Taylor & Francis Ltd., London, pp. 75-90.
- McCarthy, J.M., 2000, "Geometric design of linkages"; Springer, New York.
- McDonald, J., 2001, "On flexible body approximations of rigid body dynamics"; Proceedings of WSCG, Plzen.
- Meiling, Z., Yufeng, N., Chuanwei, Z., 2004, "A new coupled MPLG-FE method for electromagnetic field computations"; Proceedings of the IEEE ICCEA, pp. 29-32.
- Meriam, J.L., Kraige, L.G., 2003, "Engineering mechanics, Vol. 1 and 2"; John Wiley and Sons, Hoboken.
- Middendorf, W.H., 1990, "Design of devices and systems"; Marcel Dekker, Inc., New York.
- Montbrun-Di Filippo, J., Delgado, M. Brie, C. , Paynter, H.M., 1991, "A survey of bond graphs : Theory, applications and programs"; Journal of the Franklin Institute, Vol. 328, No. 5-6, pp. 565-606.
- Nutaro, J., 2006, "Discrete event simulation of continuous systems"; In: Fishwick, P.A (Ed.) Dynamic systems, to appear.
- Paynter, H.M., 1961, "Analysis and design of engineering systems"; The MIT Press, Cambridge, MA.
- Petri, C.A., 1996, "Nets, time and space"; Theoretical Computer Science, Vol. 153, pp. 3-48.
- Phillips, C.H.E., 1994, "Review of graphical notations for specifying direct manipulation interfaces"; Interacting with Computers, Vol. 6 No. 4, pp. 411-431.
- Pllana, S., Fahringer, T., 2002, "UML-based modeling of performance oriented parallel and distributed applications"; Proceedings of the 2002 Winter Simulation

- Conference, pp. 497-505.
- Poiaga, L., 2003, "Operations research in project management and cost engineering: An outlook for new operational developments"; *European Journal of Operational Research*, Vol. 41, No. 1, pp. 1-14.
- Pop, A., Savga, I., Aßmann, U., Fritzson, P., 2005, "Composition of XML dialects: A Modelica XML case study"; *Electronic Notes in Theoretical Computer Science*, Vol. 11, pp. 137-152.
- Praehofer, H., Pree, D., 1993, "Visual modeling of DEVS-based multiformalism systems based on higraphs"; *Proceedings of the Winter Simulation Conference*, pp. 595-603.
- Premože, S., Tasdizen, T., Bigler, J., Lefohn, A., Whitaker, R.T., 2003, "Particle-based simulation of fluids"; *Proceedings of Eurographics 2003*.
- Remmerswaal, J.A.M., Pacejka, H., 1989, "A bond graph computer model to simulate vacuum cleaner dynamics for design purposes"; *Journal of the Franklin Institute*, Vol. 319, pp. 83-92.
- Riley, K.F., Hobson, M.P., Bence, S.J., 1997, "Mathematical methods for physics and engineering"; Cambridge Press, Cambridge.
- Roozenburg, N.F.M., Eekels, J., 1995, "Product design: fundamentals and methods"; John Wiley & Sons, Chichester.
- Roth, K., 1982, "Konstruieren mit Konstruktionskatalogen"; Springer Verlag, Berlin.
- Rusák, Z., 2003, "Vague discrete interval modeling for product conceptualization in collaborative virtual environments"; Millpress, Rotterdam.
- Shieh, M.-Y., Li, T.-H., 1998, "Design and implementation of integrated fuzzy-logic controller for a servomotor system"; *Mechatronics*, Vol. 8, pp. 217-240.
- Shigley, J.E., Mischke, C.R., 1989, "Mechanical Engineering Design"; McGraw-Hill book company, Inc., New York..
- Sokolosky, O., Hong, H.S., 1987, "Qualitative modeling of hybrid systems"; *Proceedings of the Monterey Workshop on Engineering Automation for Computer Based Systems*.
- Stramigioli, S., 1998, "From Differentiable Manifolds to Interactive Robot Control."; Ph.D. Thesis, Delft University of Technology, Delft.
- Świder, J., Wszolek, G., 2004, "Analysis of complex mechanical systems based on the block diagrams and the matrix hybrid graph method"; *Journal of Materials Processing Technology*, Vol. 157-158, pp. 250-255.
- Terzopoulos, D., Fleischer, K., 1988, "Modeling inelastic deformation: viscoelasticity, plasticity, fracture"; *Computer Graphics*, Vol. 22, No. 4, pp. 269-278.
- Thoma, J., Halin, H.J., 1999, "Bond graphs and practical simulation"; *Simulation Practice and Theory*, Vol. 7, pp. 401-417.
- Thompson, M.T., Heimdahl, M.P.E., 1999, "An integrated development environment for prototyping safety critical systems"; *Proceedings of IEEE International Workshop on Rapid System Prototyping*, Clearwater Beach, FL."
- Tsuchiya, T., Kagawa, Y., Doi, M. and Tsuji, T., 2003, "Finite element simulation of non-linear acoustic generation in a horn loudspeaker"; *Journal of Sound and Vibration*, Vol. 266, No. 5, pp. 993-1008.
- Tsukanov, I., Shapiro, V., 2002, "The architecture of SAGE - a meshfree system based on RFM"; *Engineering with Computers*, Vol. 18, No. 4, pp. 295-311.
- Wang, S.-L., 2001, "Motion simulation with working model 2D and MSC.visualNastran 4D"; *Journal of Computing and Information Science in Engineering*, Vol. 1, pp. 193-196.
- Webster, P.M., 1994, "The application of modelling in an engineering design environment"; University of Manchester, master thesis, Dept. of Computer Science.
- Xia, S., Linkens, D.A., Bennett, S., 1993, "Automatic modelling and analysis of dynamic physical systems using qualitative reasoning and bond graphs"; *Intelligent Systems Engineering*, Vol. 3, No. 2, pp. 201-212.
- Yakovlev, A.V., Koelmans, M., Semonov, A., Kinniment, D.J., 1996, "Modelling, analysis and synthesis of asynchronous control circuits using Petri nets"; *Integration, the VLSI Journal*, Vol. 21, pp. 143-170.
- Yen, C., Masada, G.Y., 1991, "Model of a hyperelastic thin plate using the extended bond graph method"; *Journal of the Franklin Institute*, Vol. 328, No. 5-6, pp. 765-780.
- Zeid, I., 1991, "CAD/CAM theory and practice"; McGraw-Hill book company, Inc., New York..
- Zeigler, B.P., Praehofer, H., Kim, T.G., 2000, "Theory of modeling and simulation - integrating discrete event and continuous complex dynamic systems, second edition."; Academic press, San Diego.
- Zienkiewicz, O.C, Taylor, R.L., 2000, "The finite element method, Vol. 1,2,3"; Butterworth-Heinemann, Oxford.
- Zienkiewicz, O.C., Hollister, G.S. (Eds.), 1965, "Stress analysis, recent developments in numerical and experimental methods"; John Wiley and Sons, New York.