

the Cooperative Seedpod

Design approach for developing housing cooperatives

Architectural Engineering | Graduation studio

Merijn Oldenburger

15-01-2026

Supervisors:

Mo Smit

Lex van Deudekom

Tsilil Strauss

Delegate examiner:

Ellen Geurts



Research

Process

Design

Construction

In what ways can the architectural design facilitate the process of creating a Housing Cooperative?

Research

Process

Design

Construction

Housing cooperative Seedpod



Research question

A housing cooperative is an **association** with full legal capacity that aims to enable its members to independently provide for the **management and maintenance** of the residential properties they occupy and the immediately adjacent environment.

(article 18a of dutch housing law)

Research

Process

Design

Construction

Housing cooperative Seedpod



Housing cooperative

Creating a network of inter-cooperative collaboration through a shared product

Research

Process

Design

Construction

Housing cooperative Seedpod



Goal

the Seedpod

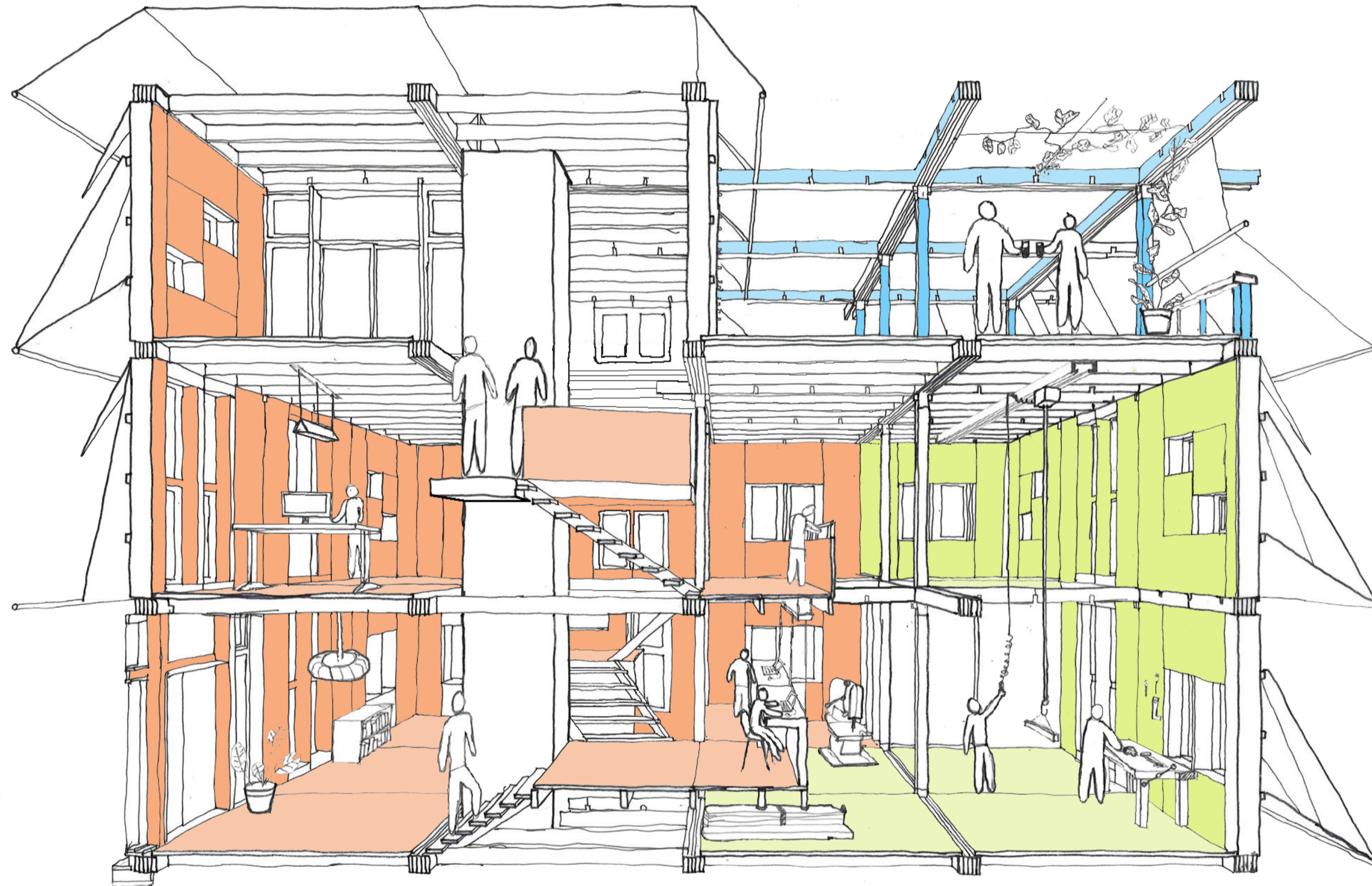
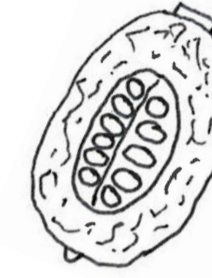

Research

Process

Design

Construction

Housing cooperative Seedpod



Two point perspective of use

the Seedpod



Research

Process

Design

Construction

Housing cooperative Seedpod



1:20 Model

0-5

5-7

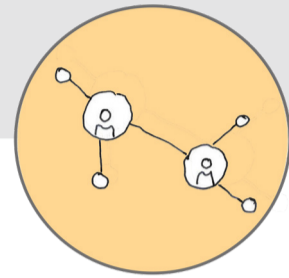

1. Formation of a HCoop
2. Enlisting HCoop overview
3. Selection for a location
4. Selection through vision
5. Method and Case presentation
6. Option agreement
7. Leasehold agreement

8. Delivery plot
9. Start of the building process

Ownership!

5-7

Social housing wait list

Research

Process

Design

Construction

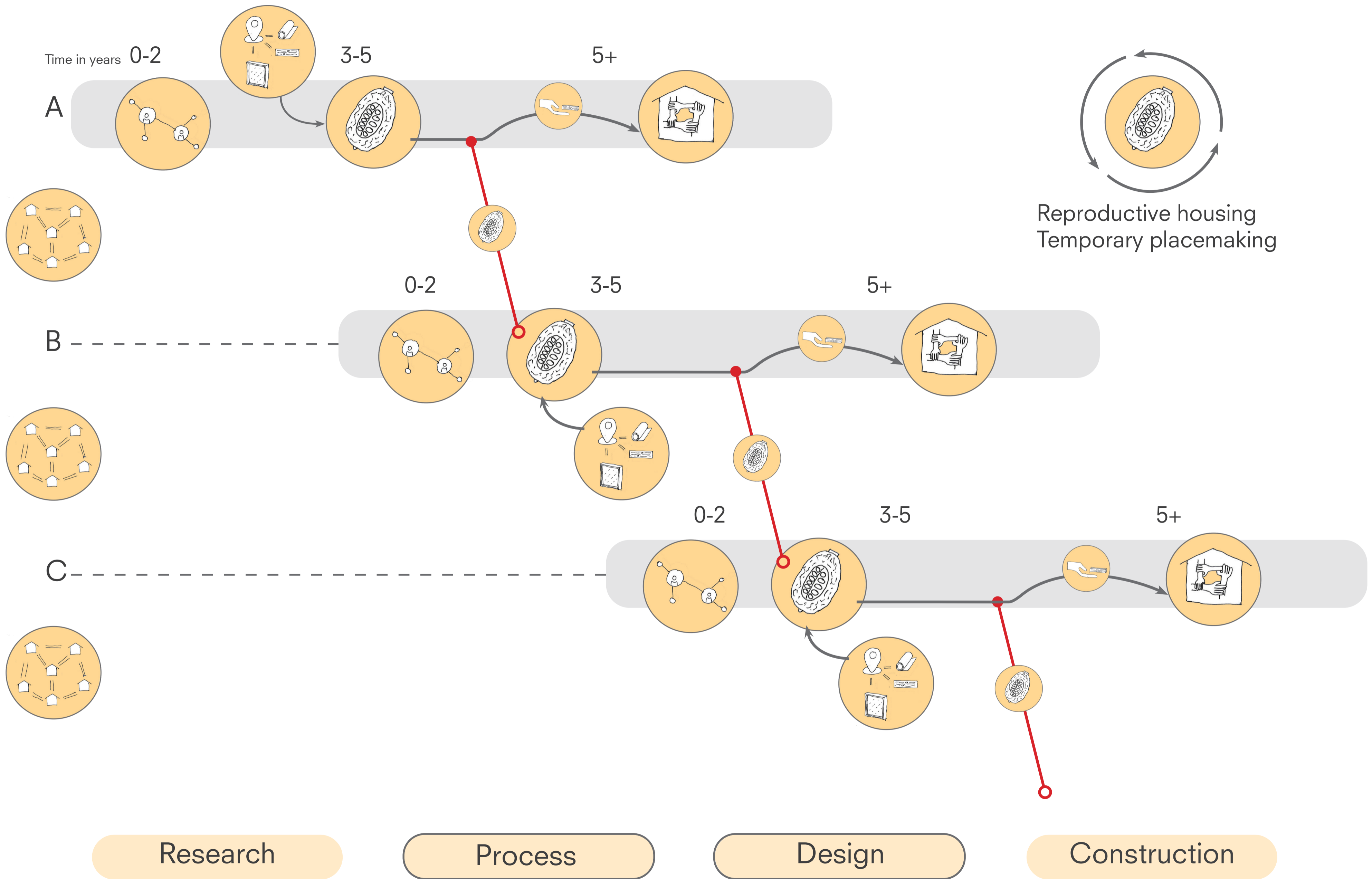

Seedpod
Core



Seedpod
project requirements

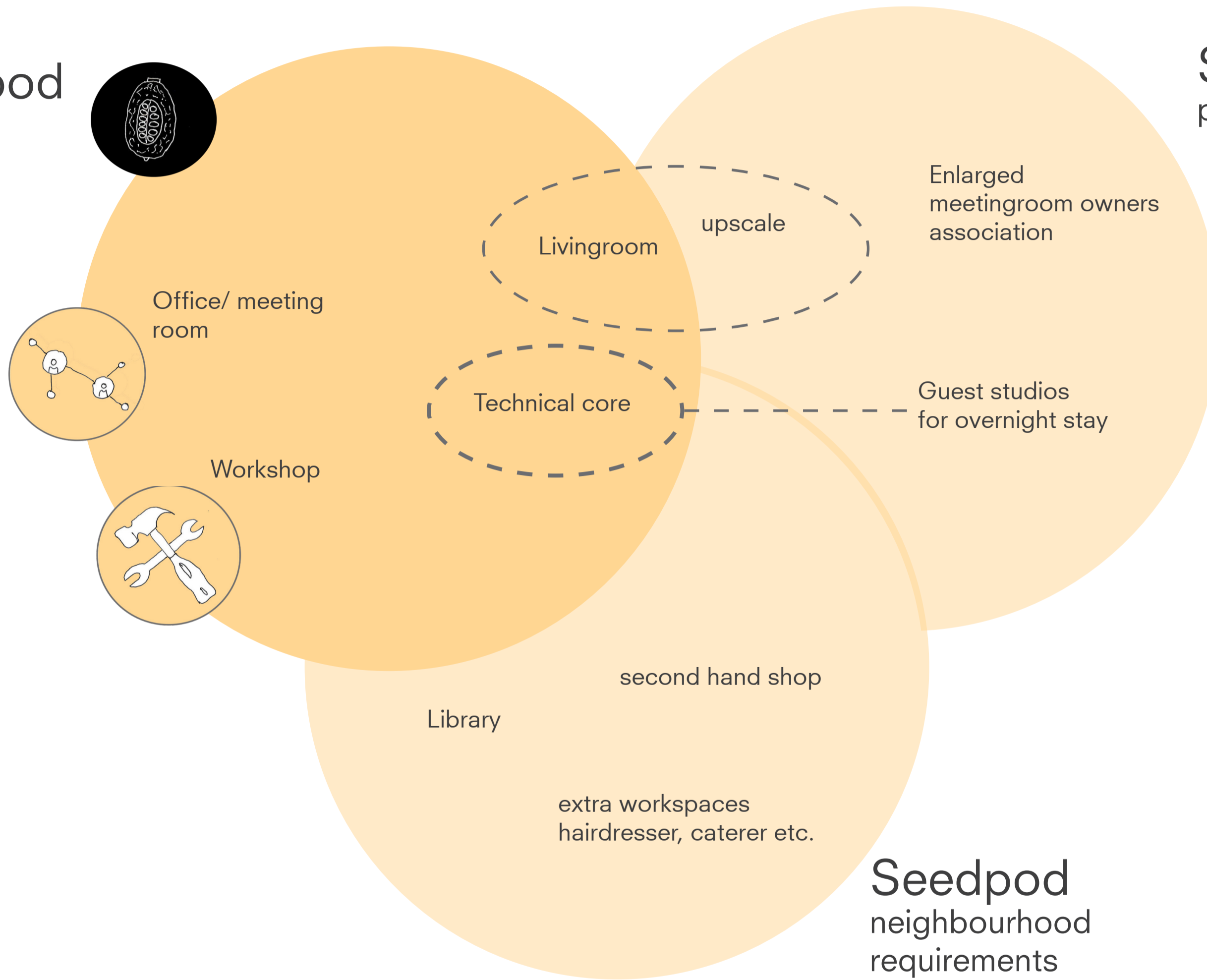

Research

Process

Design

Construction

Housing cooperative Seedpod



Design vs self-development

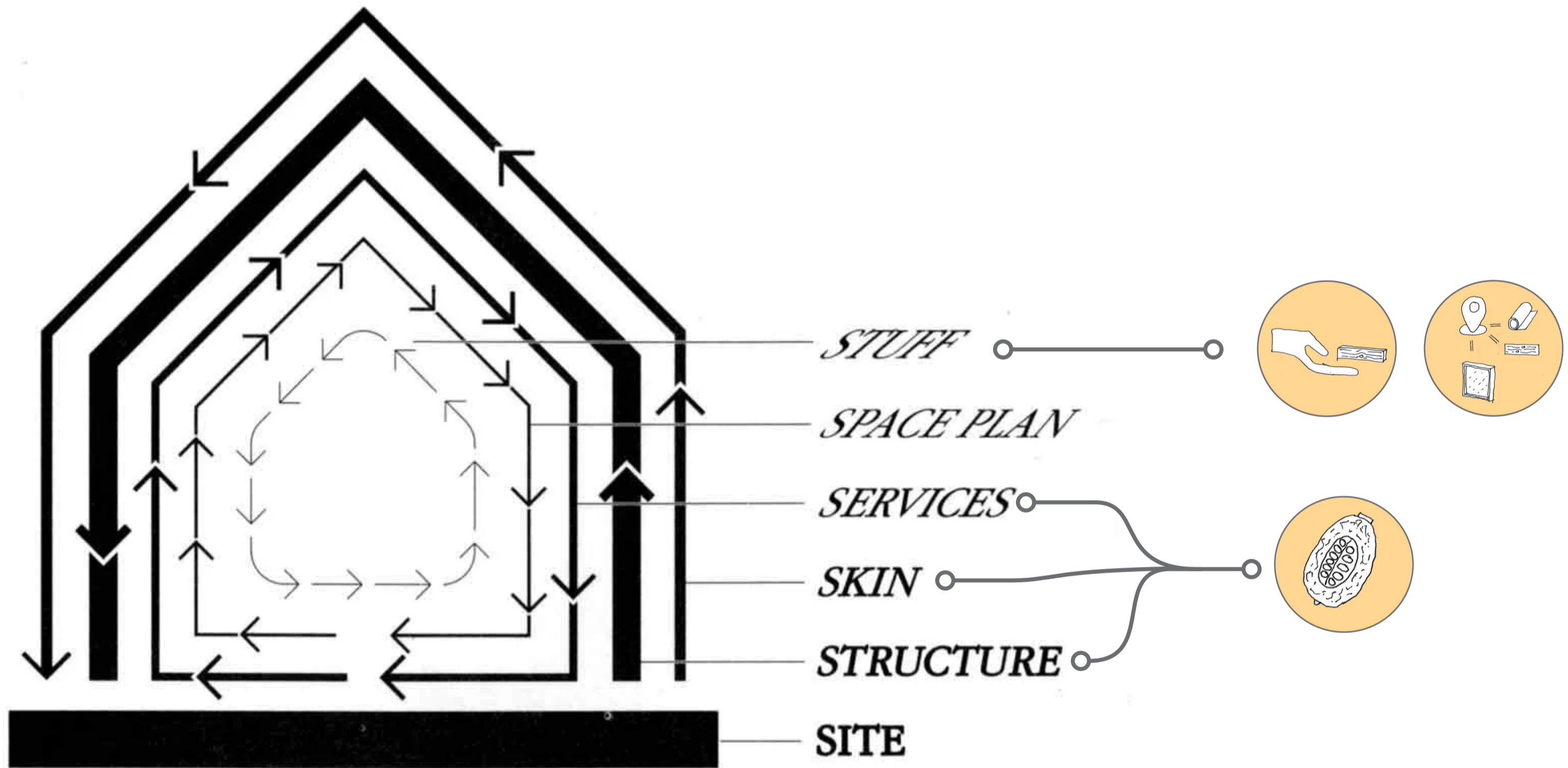

Shearing layers - Steward Brand

Research

Process

Design

Construction

Housing cooperative Seedpod



Layers

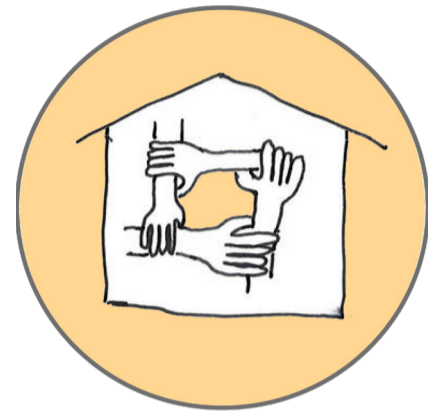

De Bundel, Amsterdam

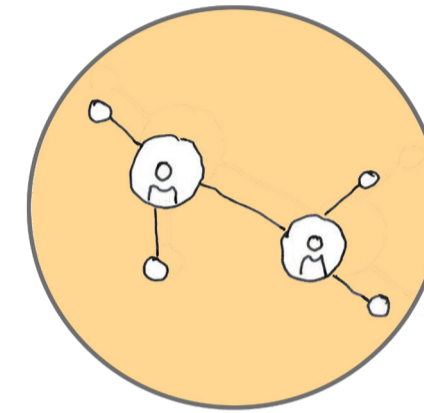

Funding, negotiations, presenting

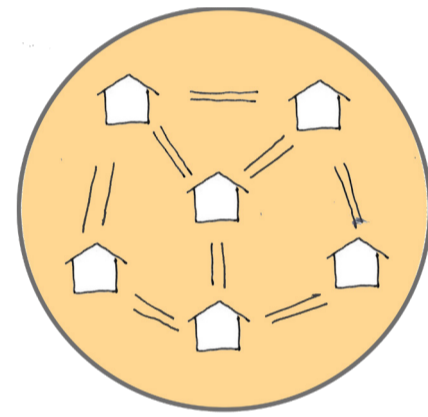

Advantages of inter-cooperative collaboration



Do-It-Together, selfbuilding

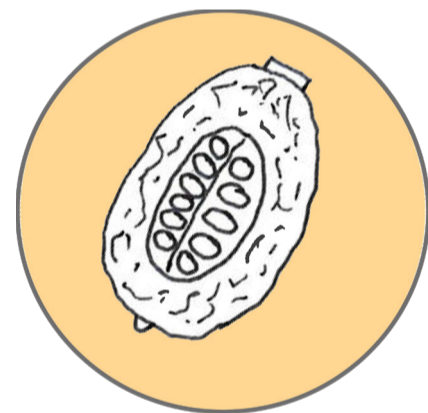

Implementation of the Seedpod



Workspace, greater place attachment

Research

Process

Design

Construction

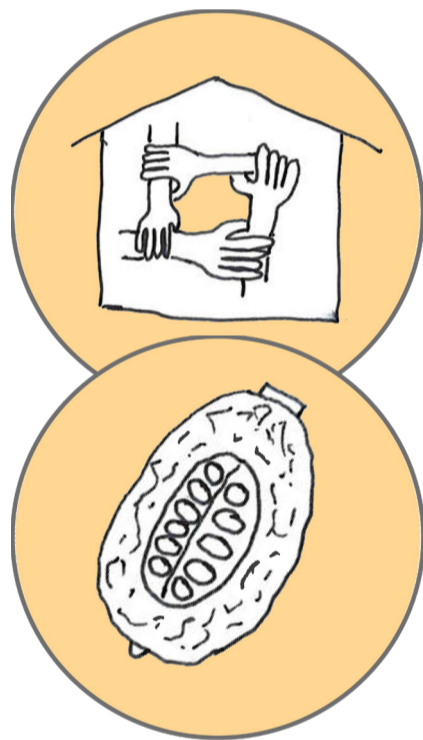

Catalyst for development
Similar to creative industries in de-industrialized
urban areas like Merwe-Vierhaven

Research

Process

Design

Construction





Research

Process

Design

Construction

Housing cooperative Seedpod



1:20 Model

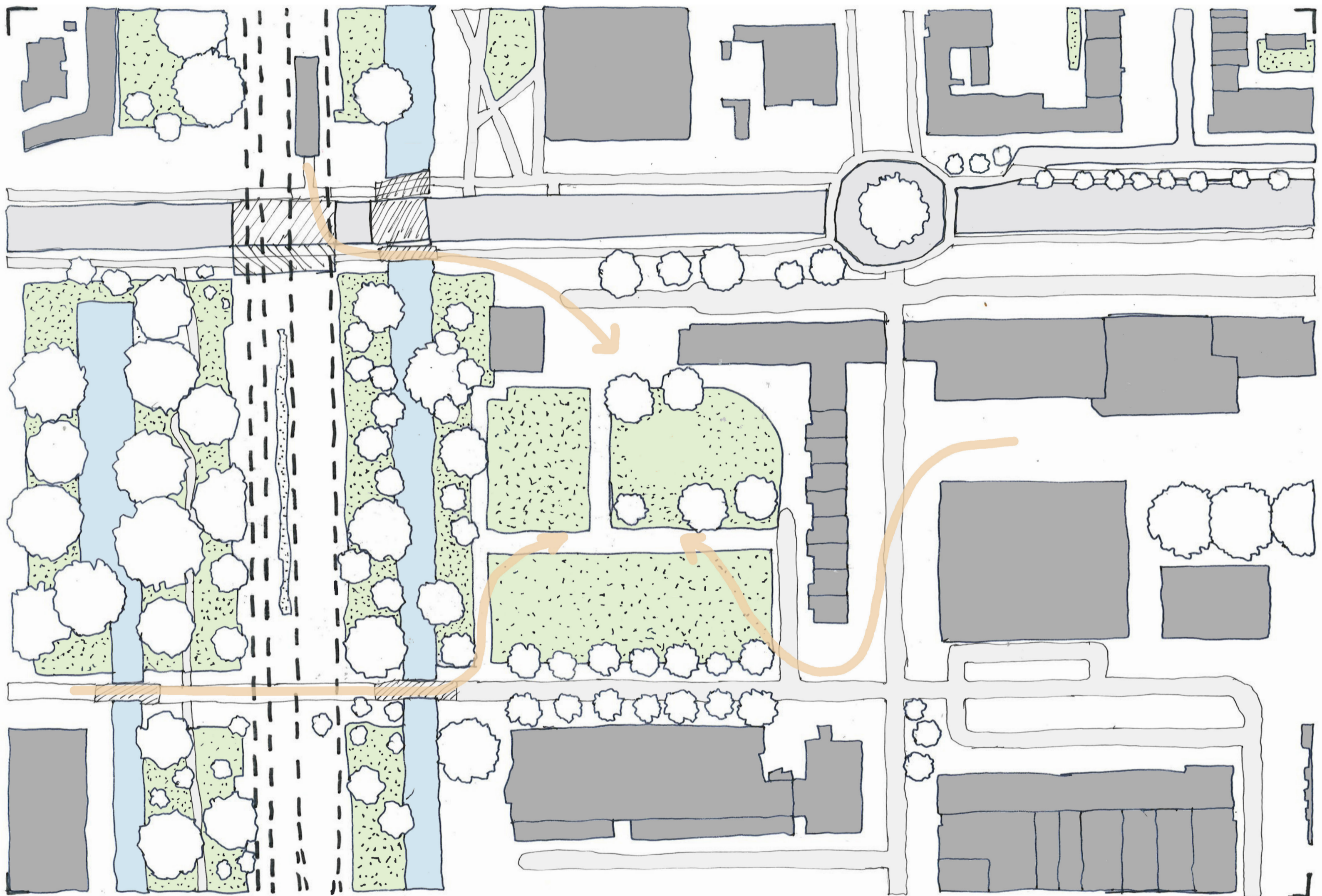

Willem roelofstraat 1/1000 ▲

Research

Process

Design

Construction

Housing cooperative Seedpod



Context

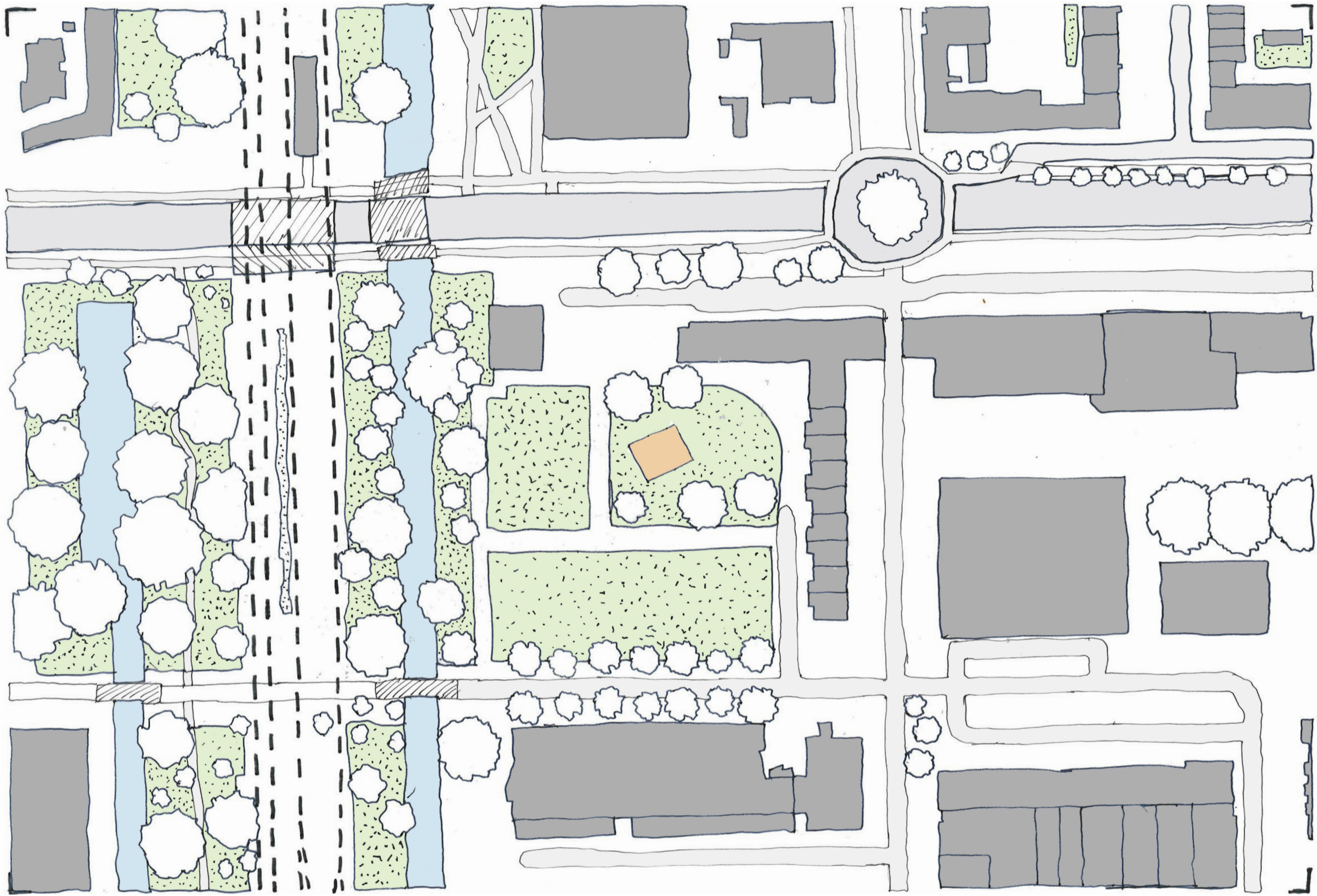

Willem roelofstraat 1/1000 ▲

Research

Process

Design

Construction

Housing cooperative Seedpod



Context

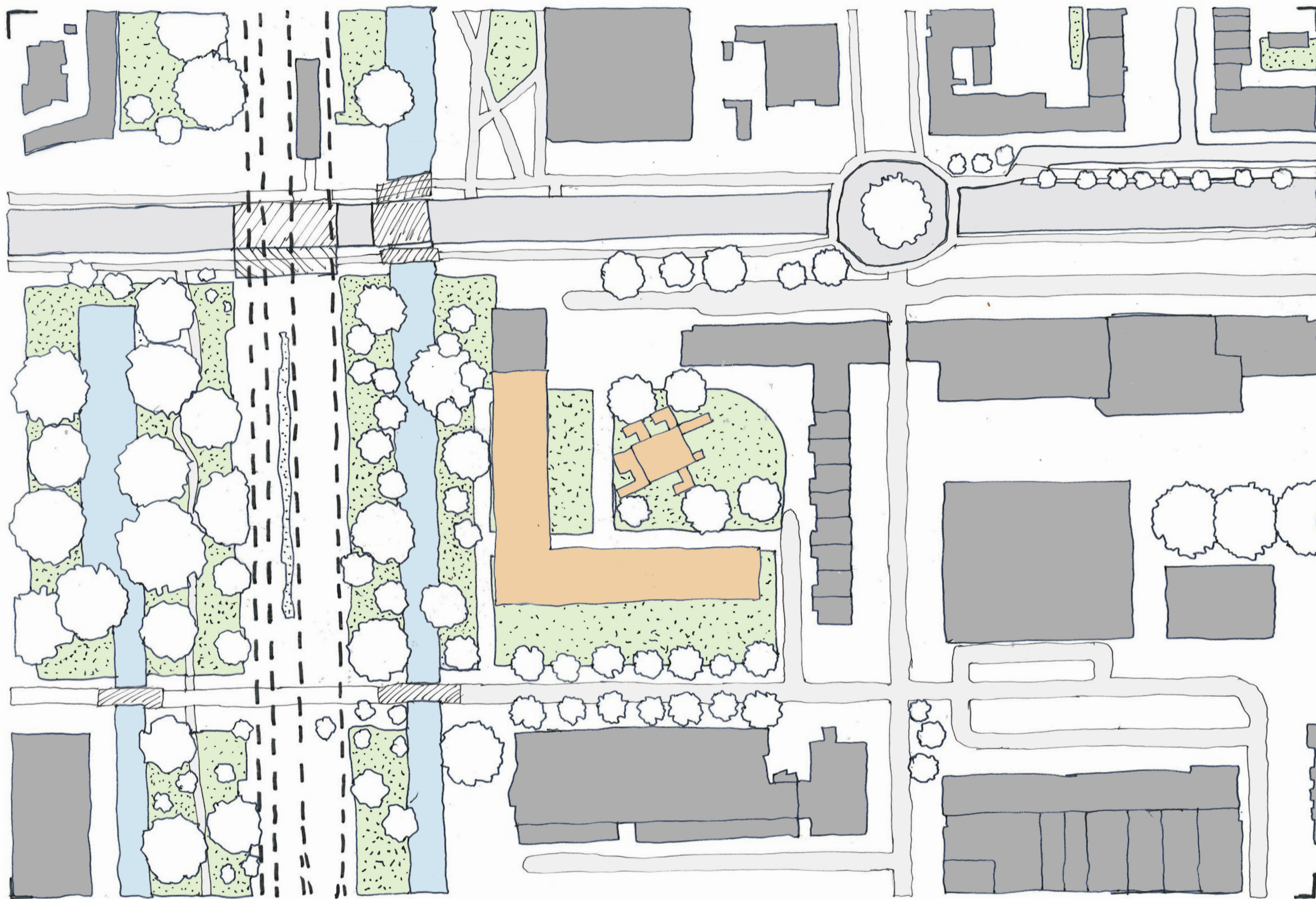

Willem roelofstraat 1/1000 ▲

Research

Process

Design

Construction

Housing cooperative Seedpod



Context

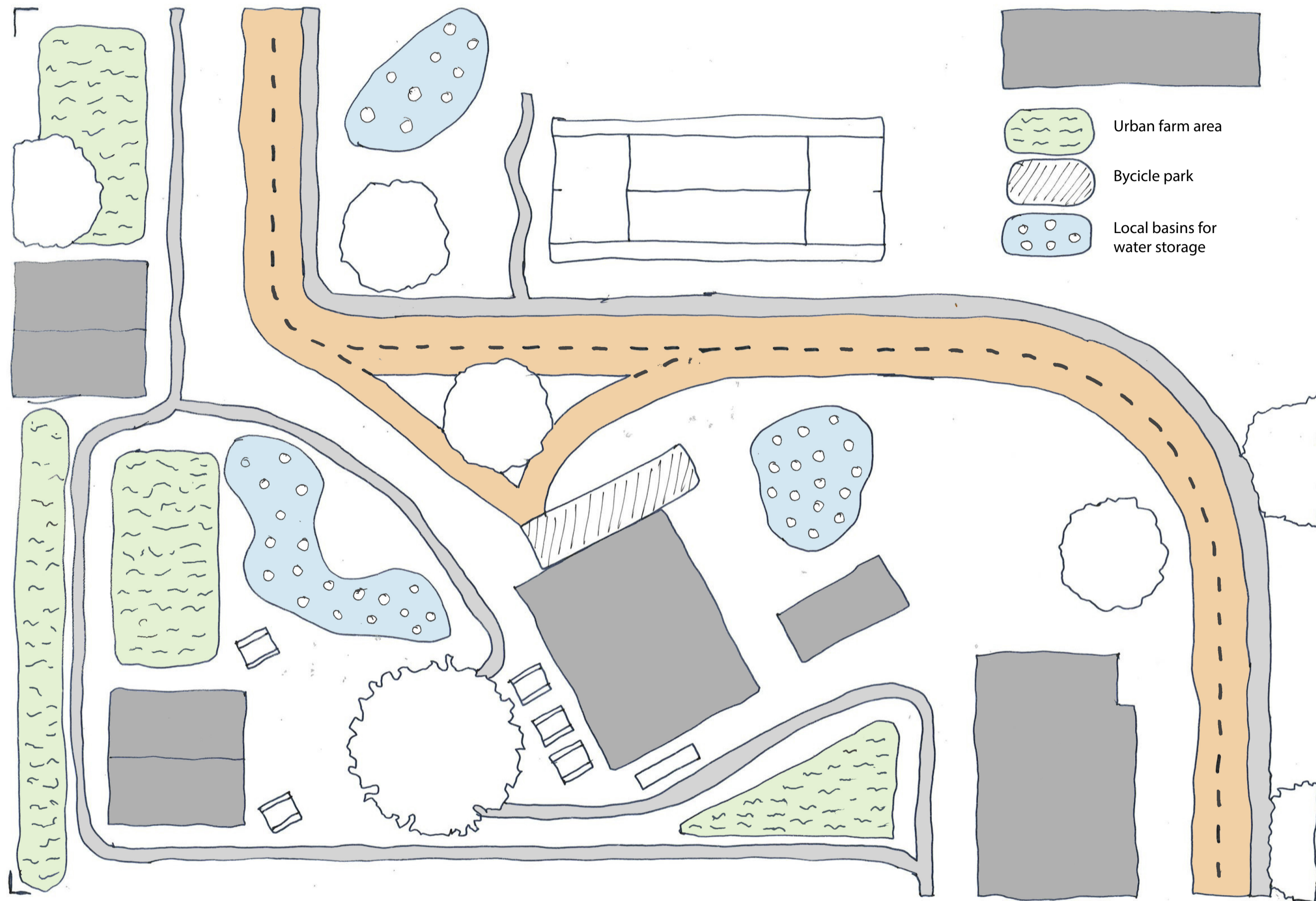

Research

Process

Design

Construction



Research

Process

Design

Construction

Housing cooperative Seedpod



1:20 Model



Research

Process

Design

Construction

Housing cooperative Seedpod



1:20 Model

Housing cooperative De Bundel

120 Households -> 12 Living groups
Meeting room 12 persons

	Surface area m ²	Notes	Temp C	Ventilation	Light	Sound
Meetingroom/ Office	36	Scales with project size	18-24	23,4 m ³ /h/ pp 280 m ³ /h	Daylight Can be darkened	Damp against reverb
Kitchen	9-18	Can include living space	18-24	50 m ³ /h	Daylight	
Livingroom	36-72	Scales with needs of neighborhood	18-24	3,4 m ³ /h/m ²	Daylight	
Guest rooms	27	Can be excluded when project has sufficient connection	18-24	3,4 m ³ /h/m ²	Daylight Can be darkened	
Workshop	36	First room to be realised, facilitates in construction	10-25	50 m ³ /h	No daylight mandatory, when present can be darkened	Damp against contact noise
Toilets	9	Next to stairs (core)	18-24	50 m ³ /h		

Research

Process

Design

Construction

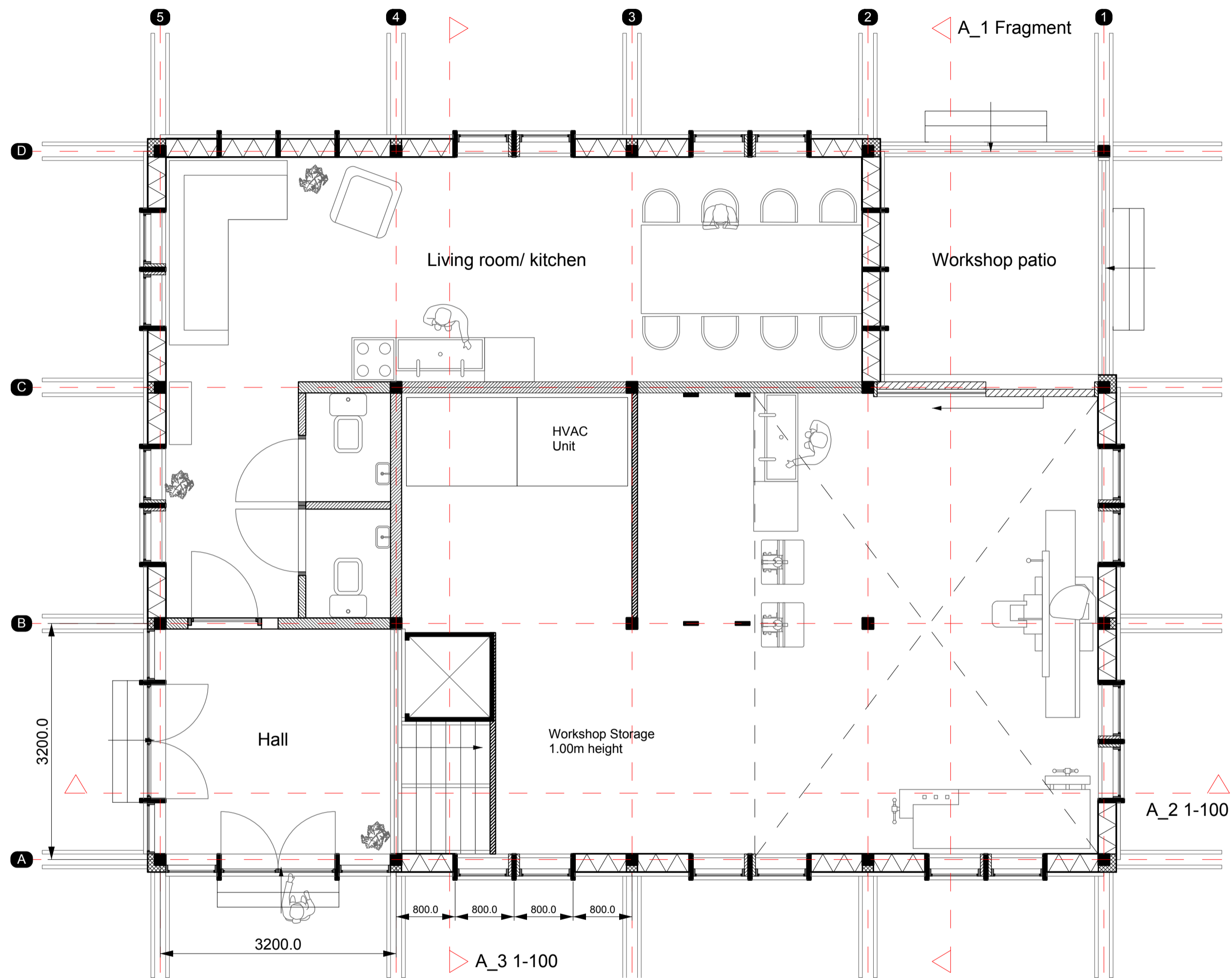

1:50 Ground floor ↗

Research

Process

Design

Construction

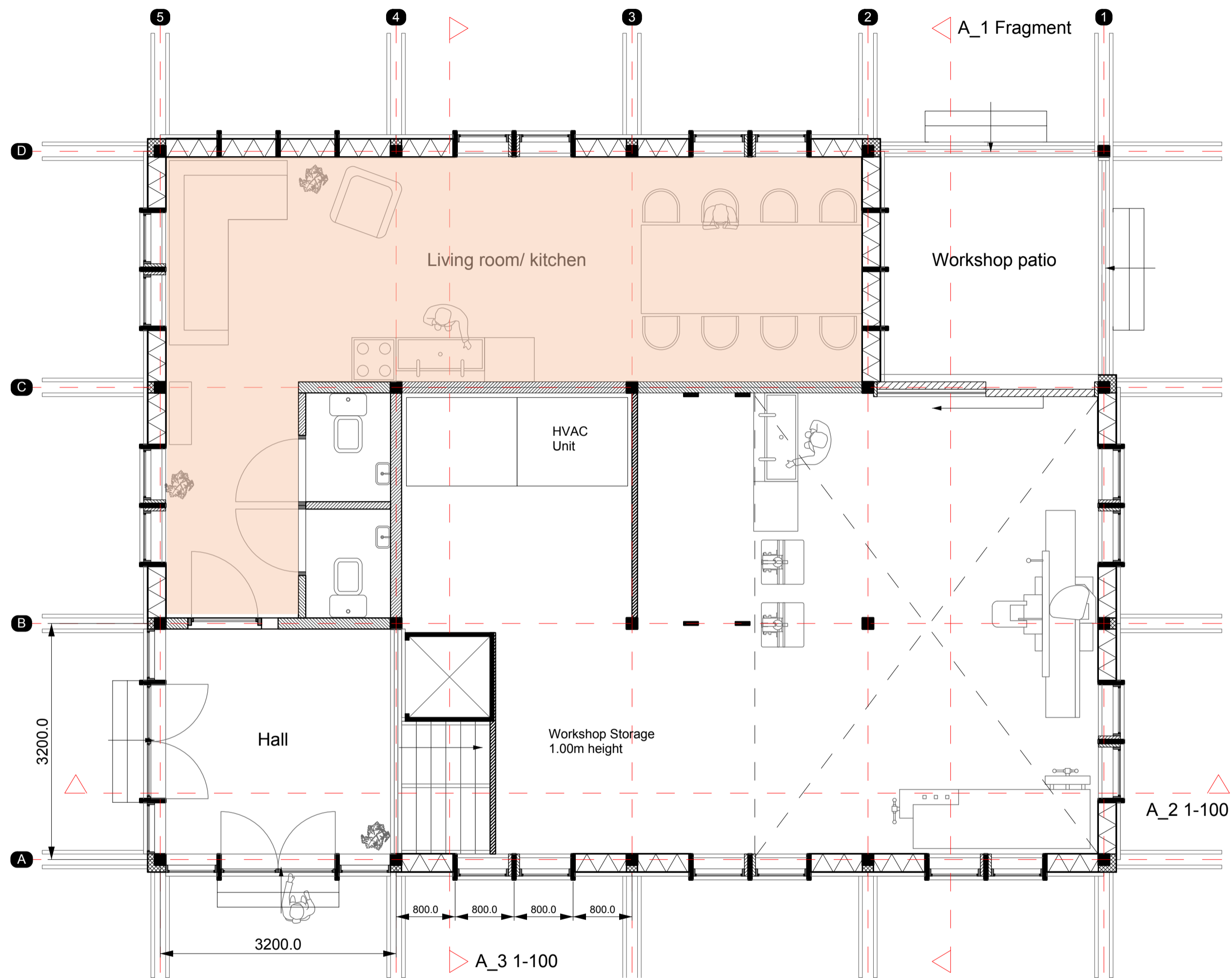

1:50 Ground floor ↗

Research

Process

Design

Construction



Research

Process

Design

Construction

Housing cooperative Seedpod



1:20 Model

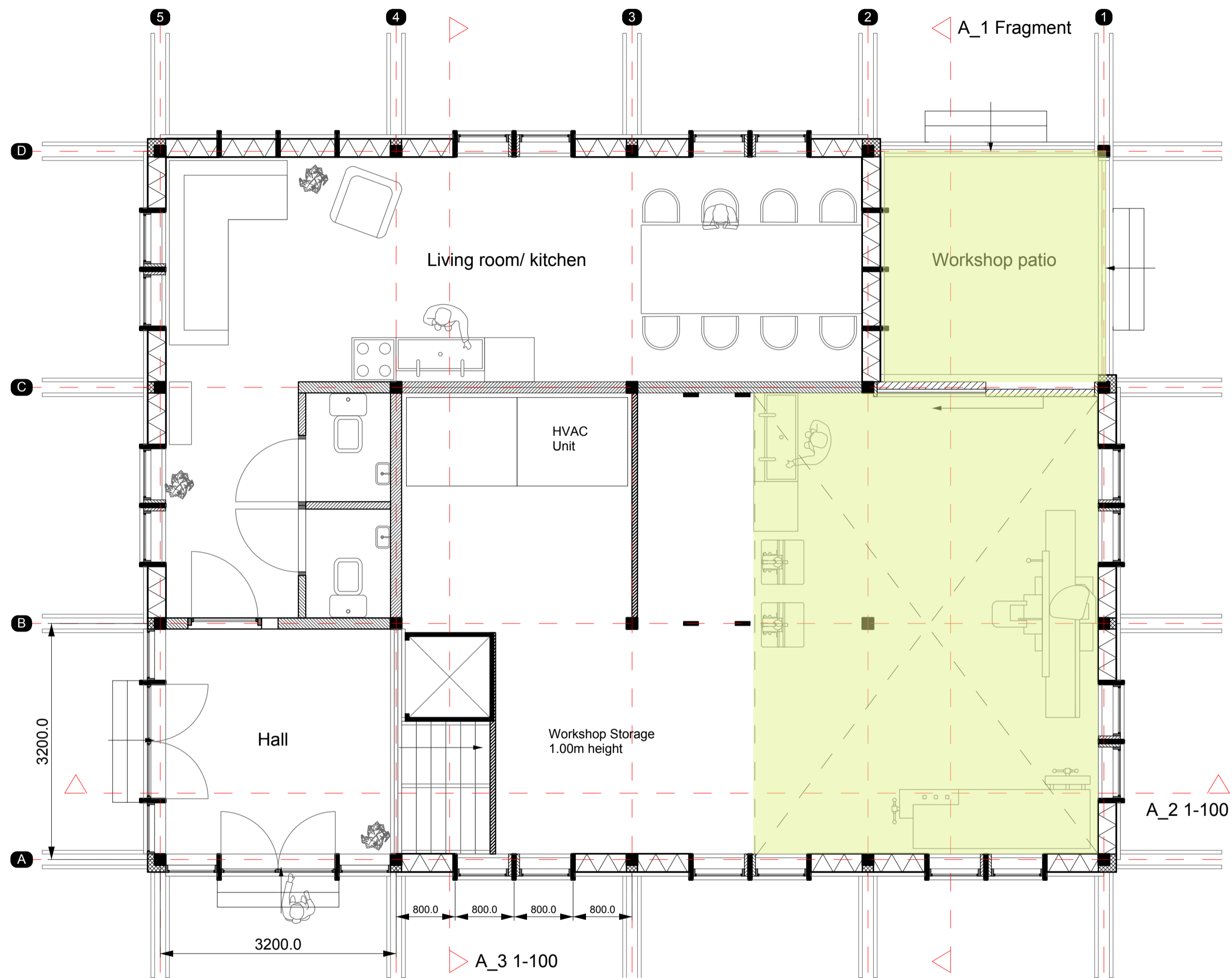

1:50 Ground floor ↗

Research

Process

Design

Construction



Research

Process

Design

Construction

Housing cooperative Seedpod



1:20 Model

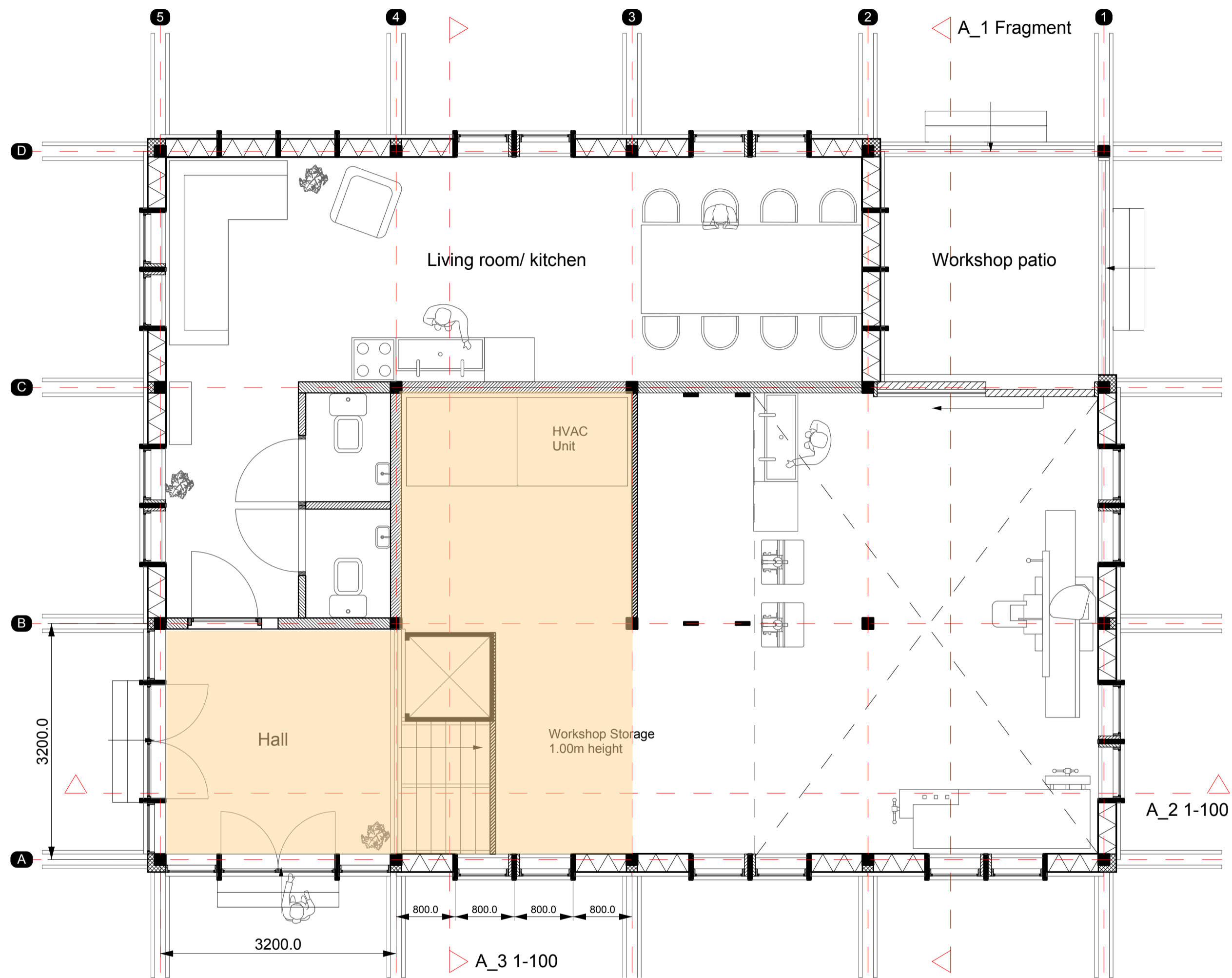

1:50 Ground floor ↗

Research

Process

Design

Construction



Research

Process

Design

Construction

Housing cooperative Seedpod



1:20 Model

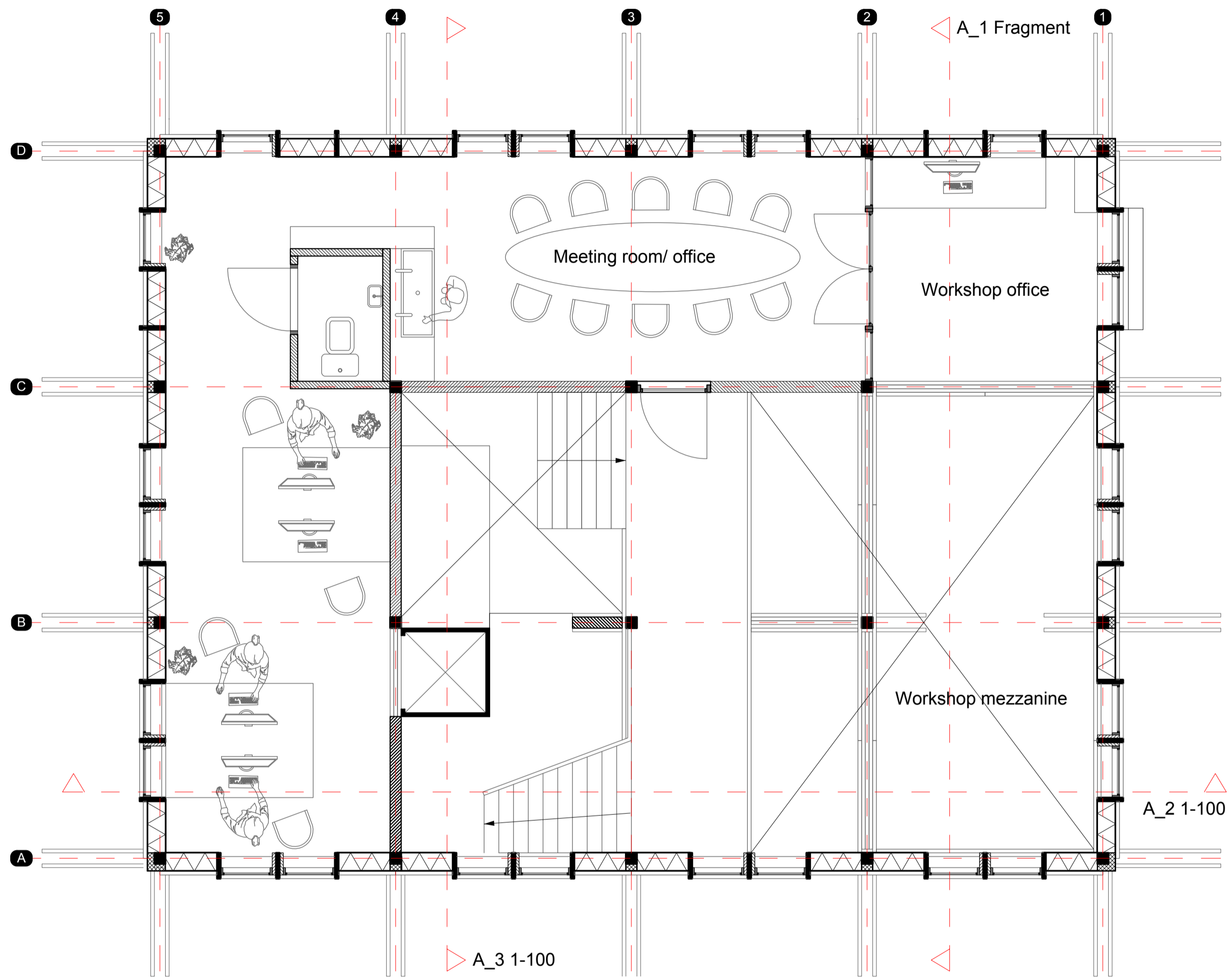

1:50 1st floor 

Research

Process

Design

Construction

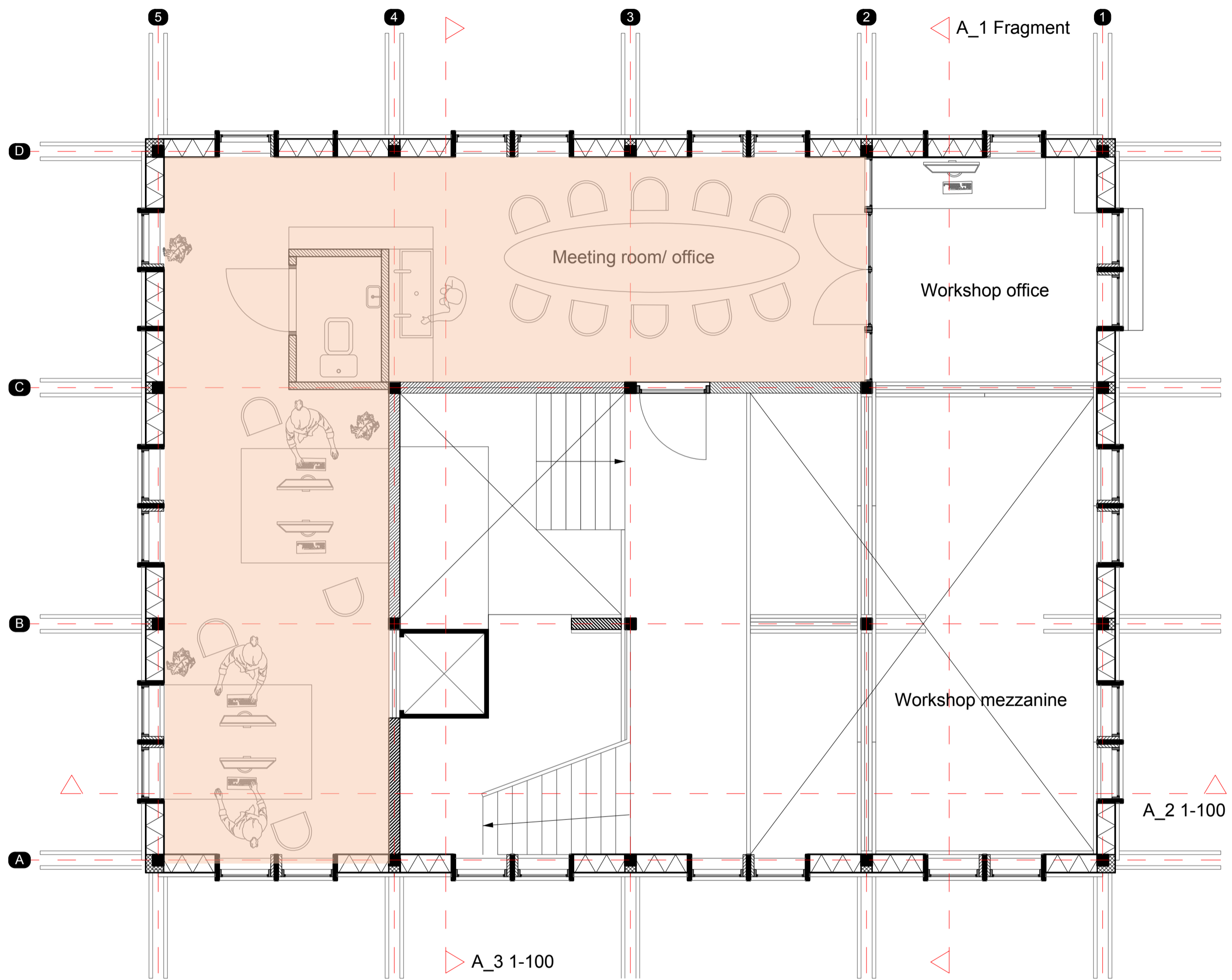

1:50 1st floor 

Research

Process

Design

Construction

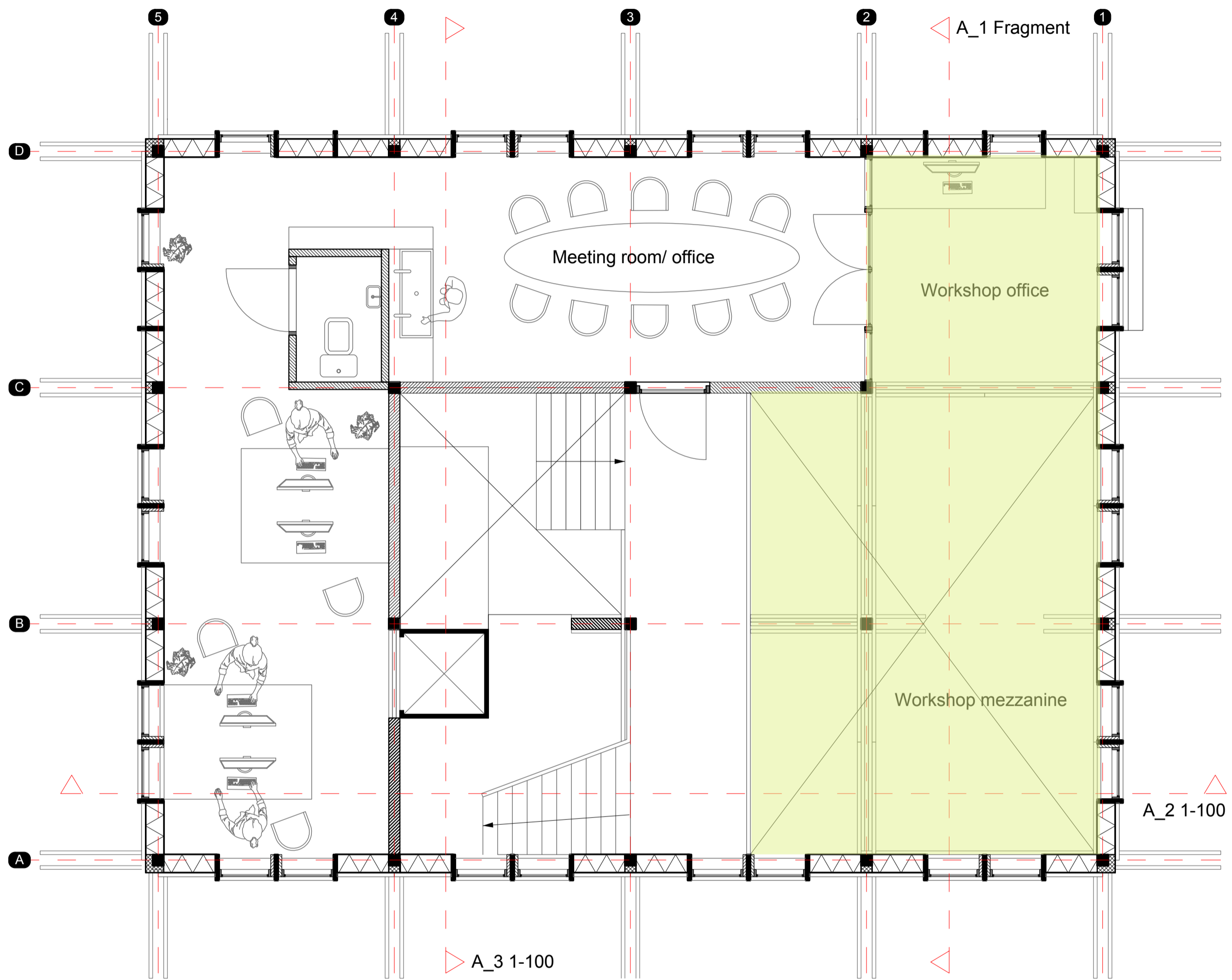

1:50 1st floor 

Research

Process

Design

Construction



Research

Process

Design

Construction

Housing cooperative Seedpod



1:20 Model

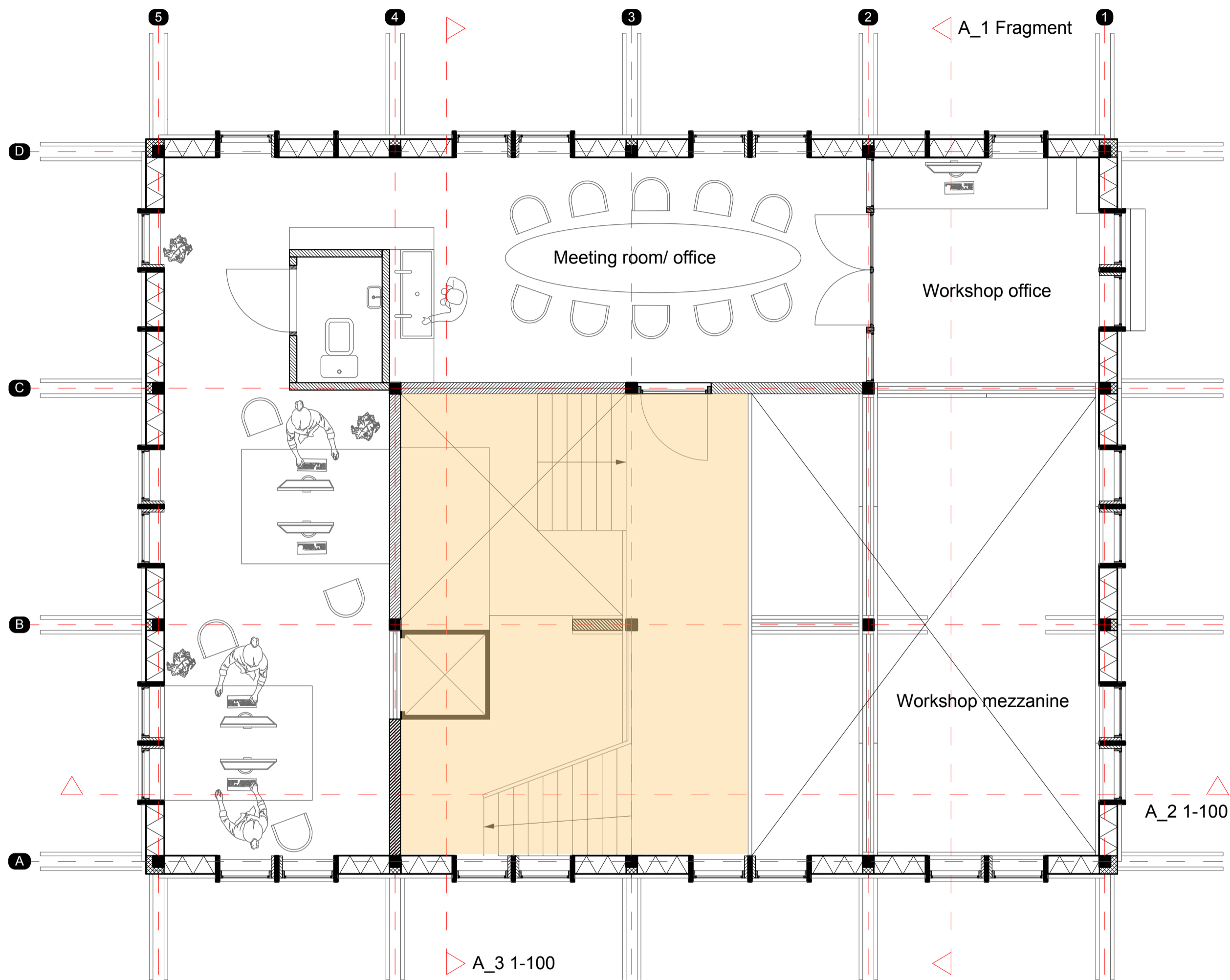

1:50 1st floor 

Research

Process

Design

Construction



Research

Process

Design

Construction

Housing cooperative Seedpod



1:20 Model

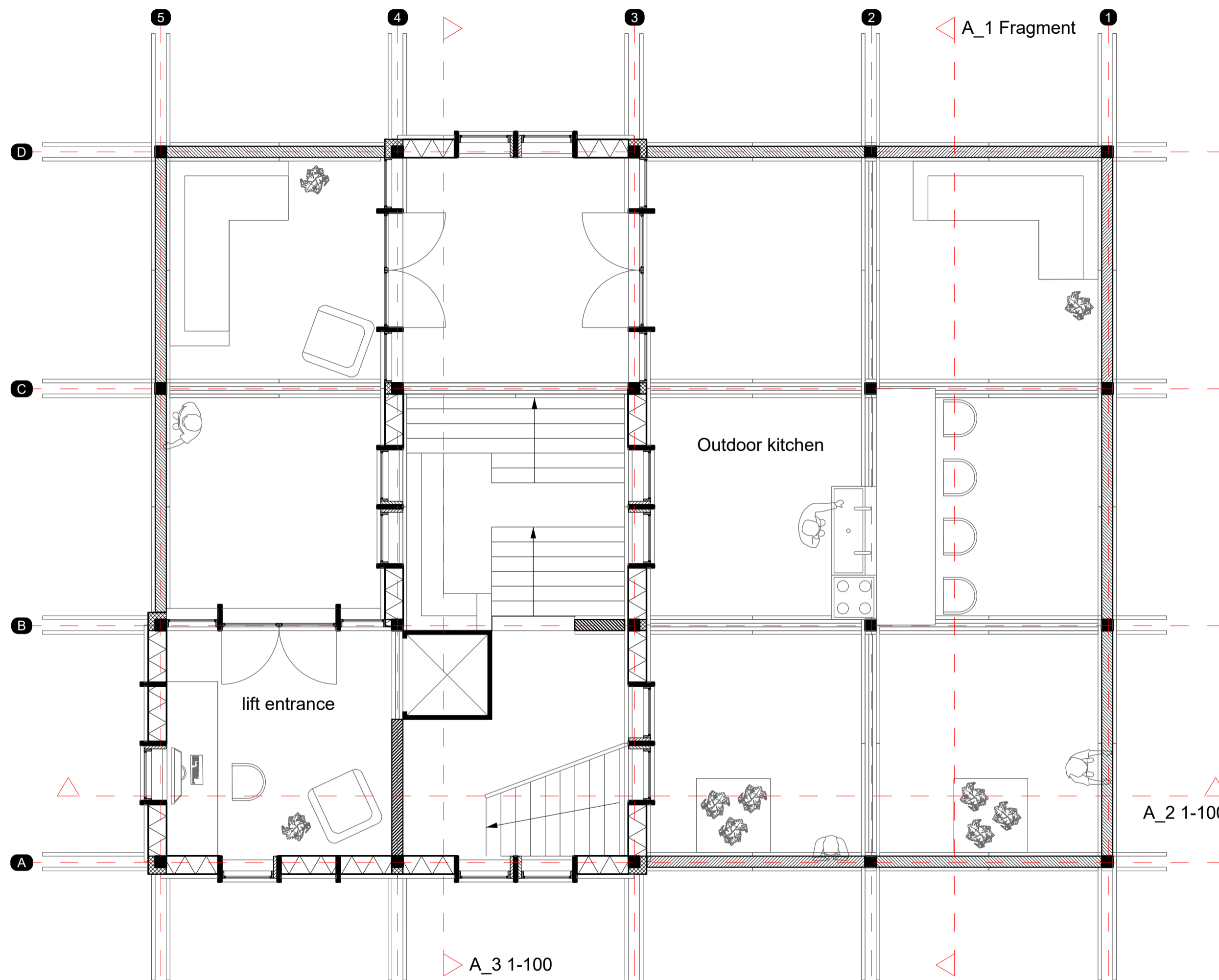

1:50 2nd floor 

Research

Process

Design

Construction

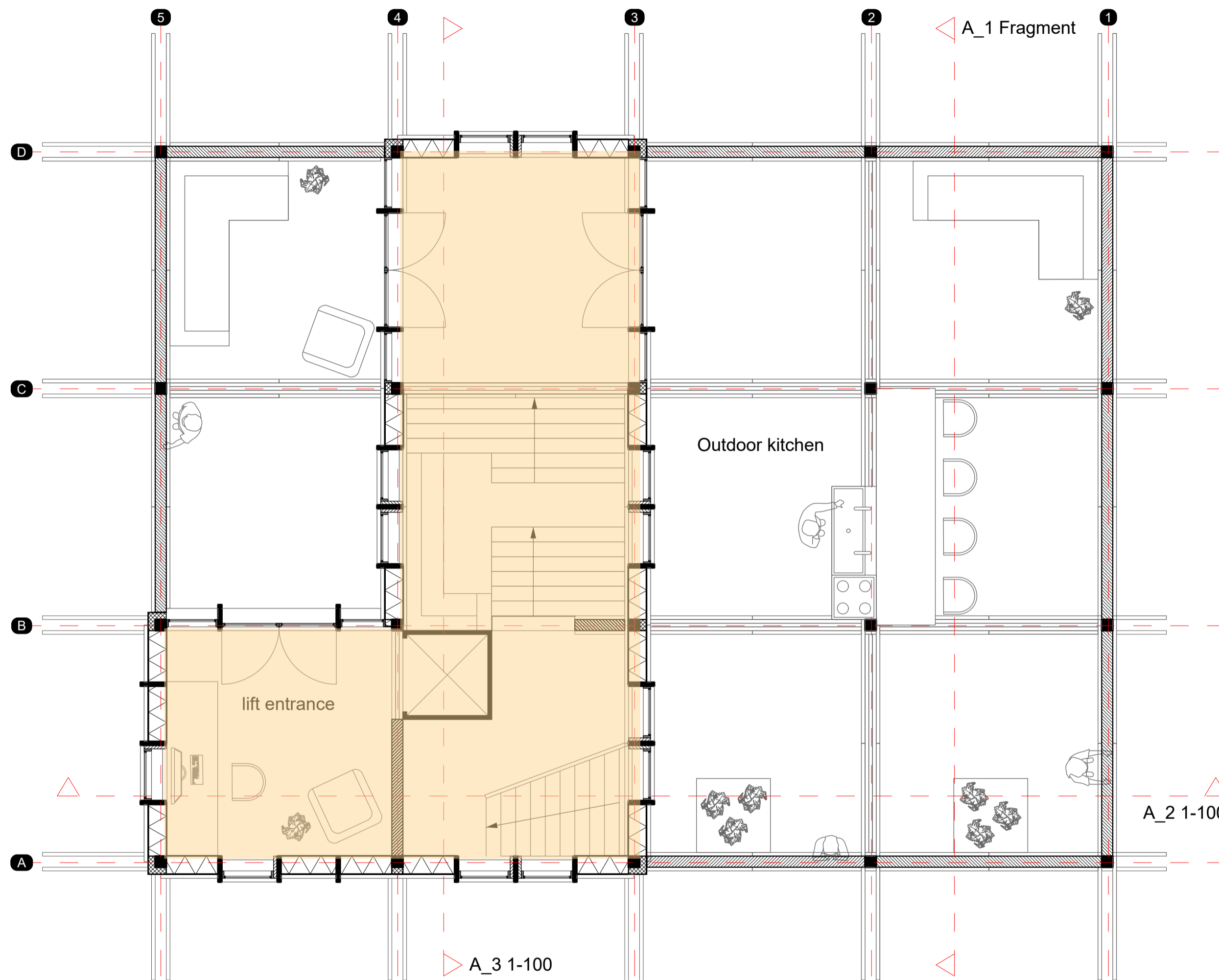

1:50 2nd floor 

Research

Process

Design

Construction



Research

Process

Design

Construction

Housing cooperative Seedpod



1:20 Model

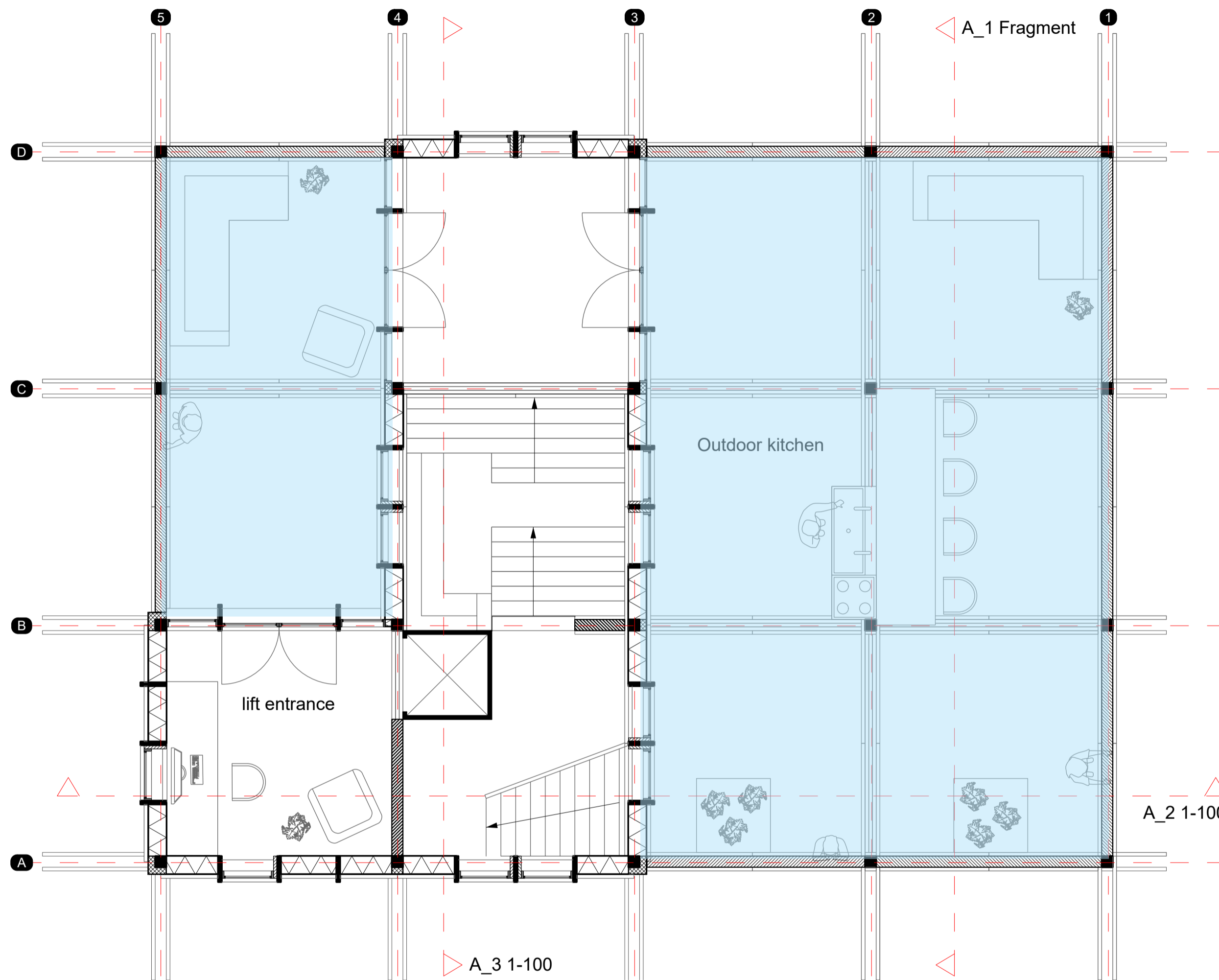

1:50 2nd floor 

Research

Process

Design

Construction



Research

Process

Design

Construction

Housing cooperative Seedpod



1:20 Model



Research

Process

Design

Construction

Housing cooperative Seedpod



1:20 Model

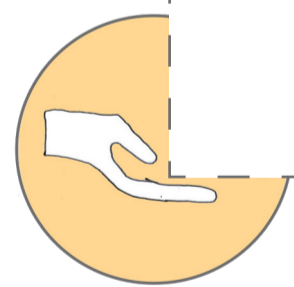

High need? flexible use

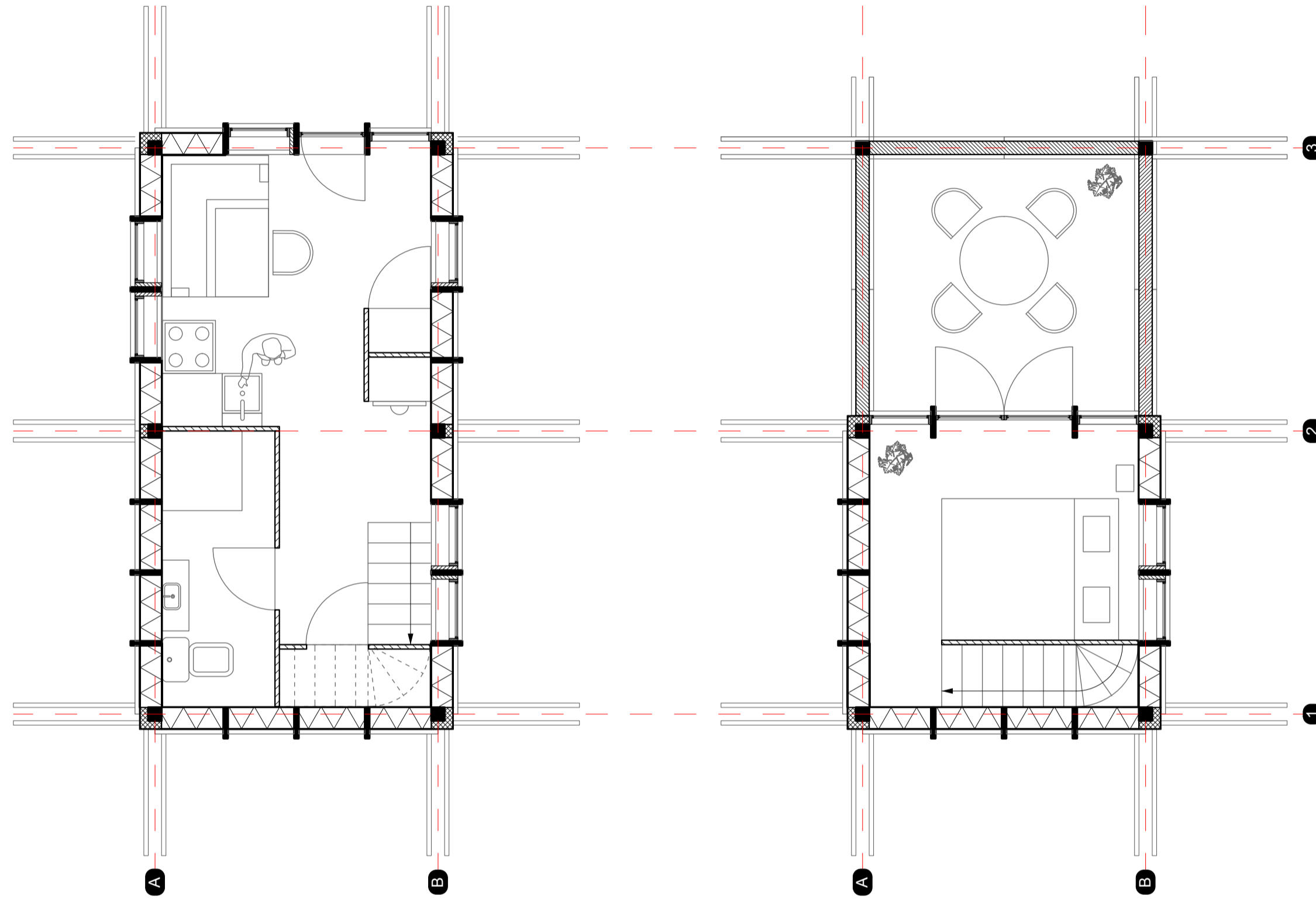

1:50 Studio
Orientation is undefined,
user can decide in a later phase

Research

Process

Design

Construction

Housing cooperative Seedpod



Plans

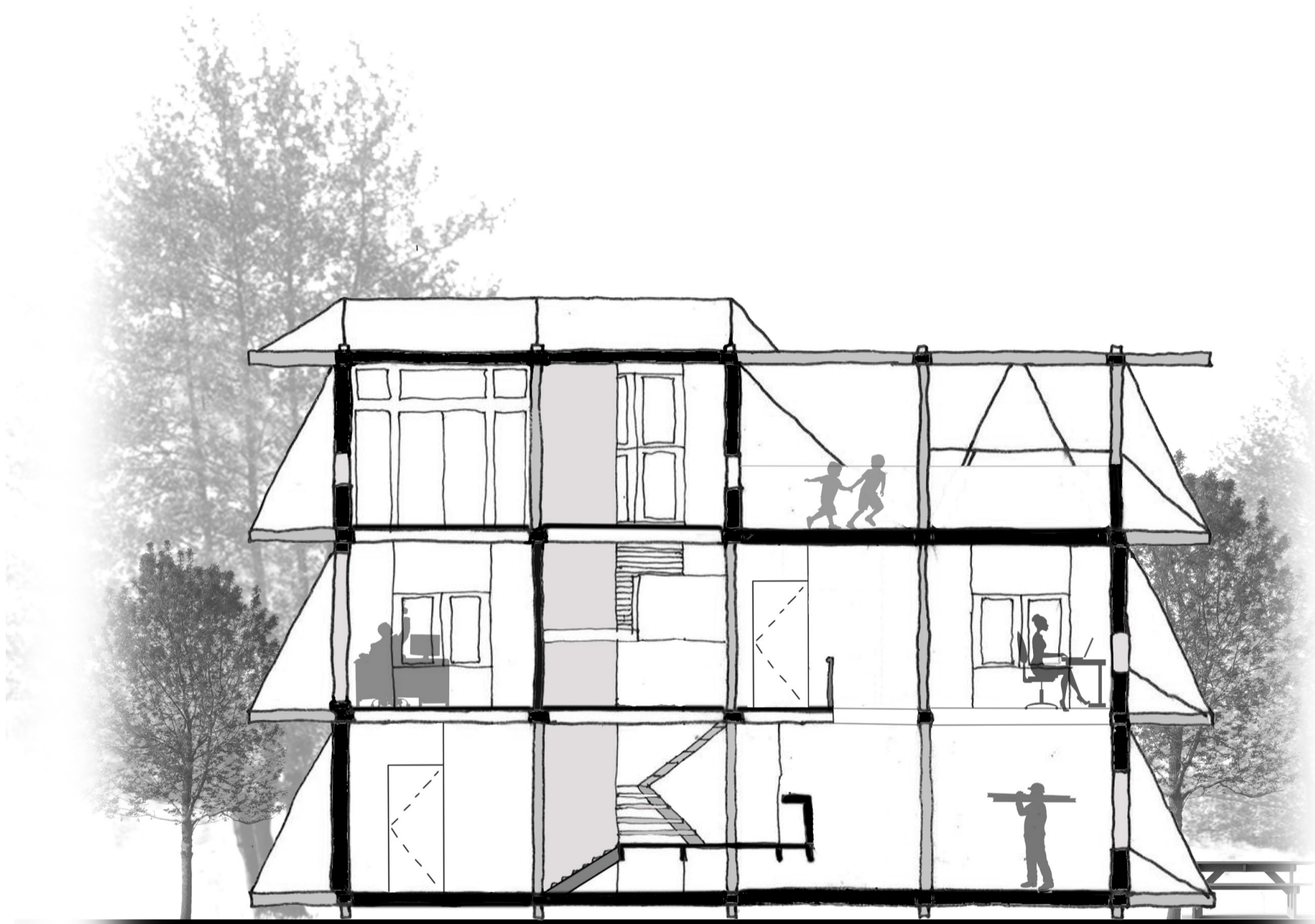

Section A2 1:100 scaled

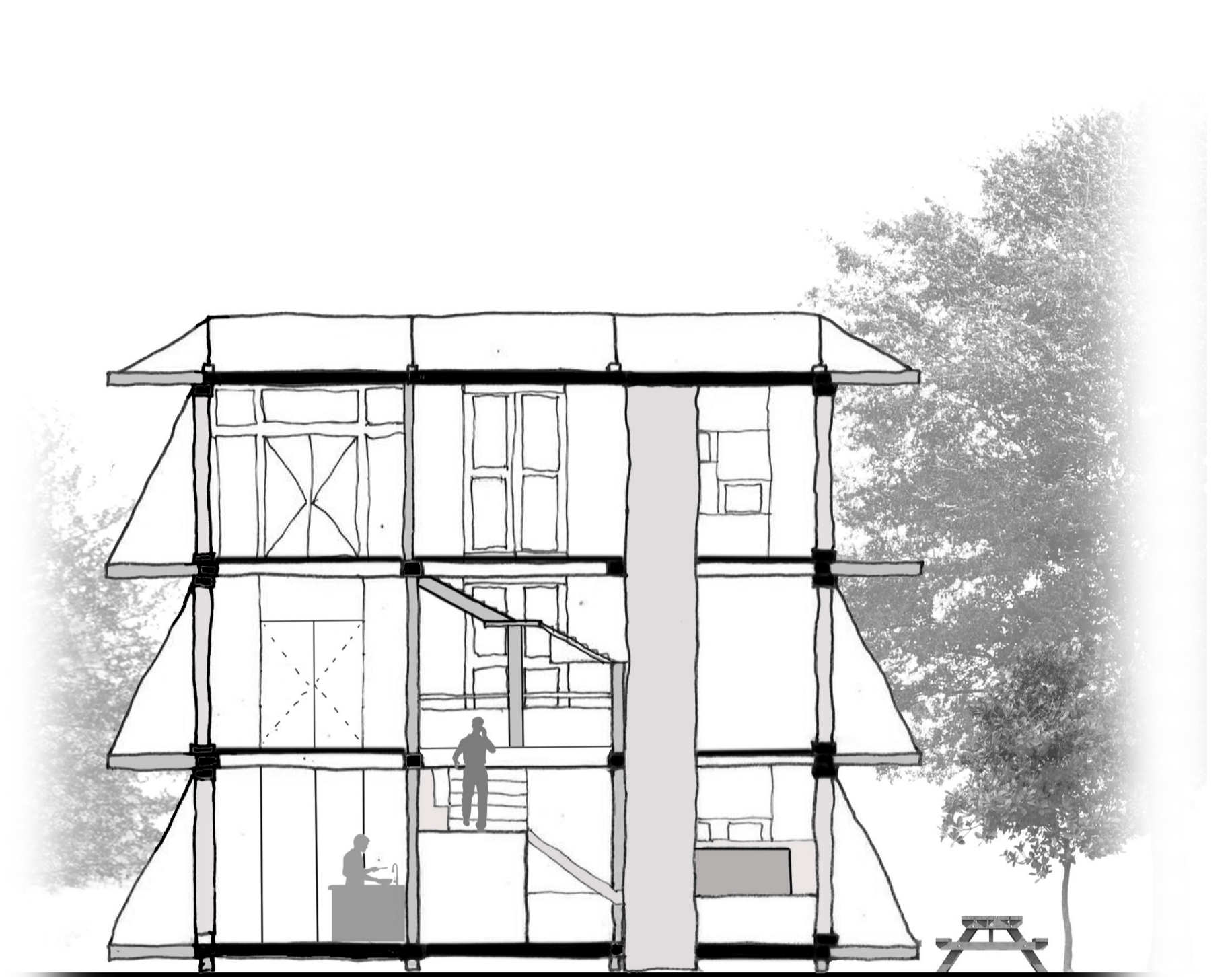

Section A3 1:100 scaled

Research

Process

Design

Construction

Housing cooperative Seedpod



Sections



South West elevation 1:100 scaled

Research

Process

Design

Construction

Housing cooperative Seedpod



Elevation



North West elevation 1:100 scaled

Research

Process

Design

Construction

Housing cooperative Seedpod



Elevation



Research

Process

Design

Construction

Housing cooperative Seedpod



Elevation



Research

Process

Design

Construction

Housing cooperative Seedpod



1:20 Model



Research

Process

Design

Construction

Housing cooperative Seedpod



1:20 Model

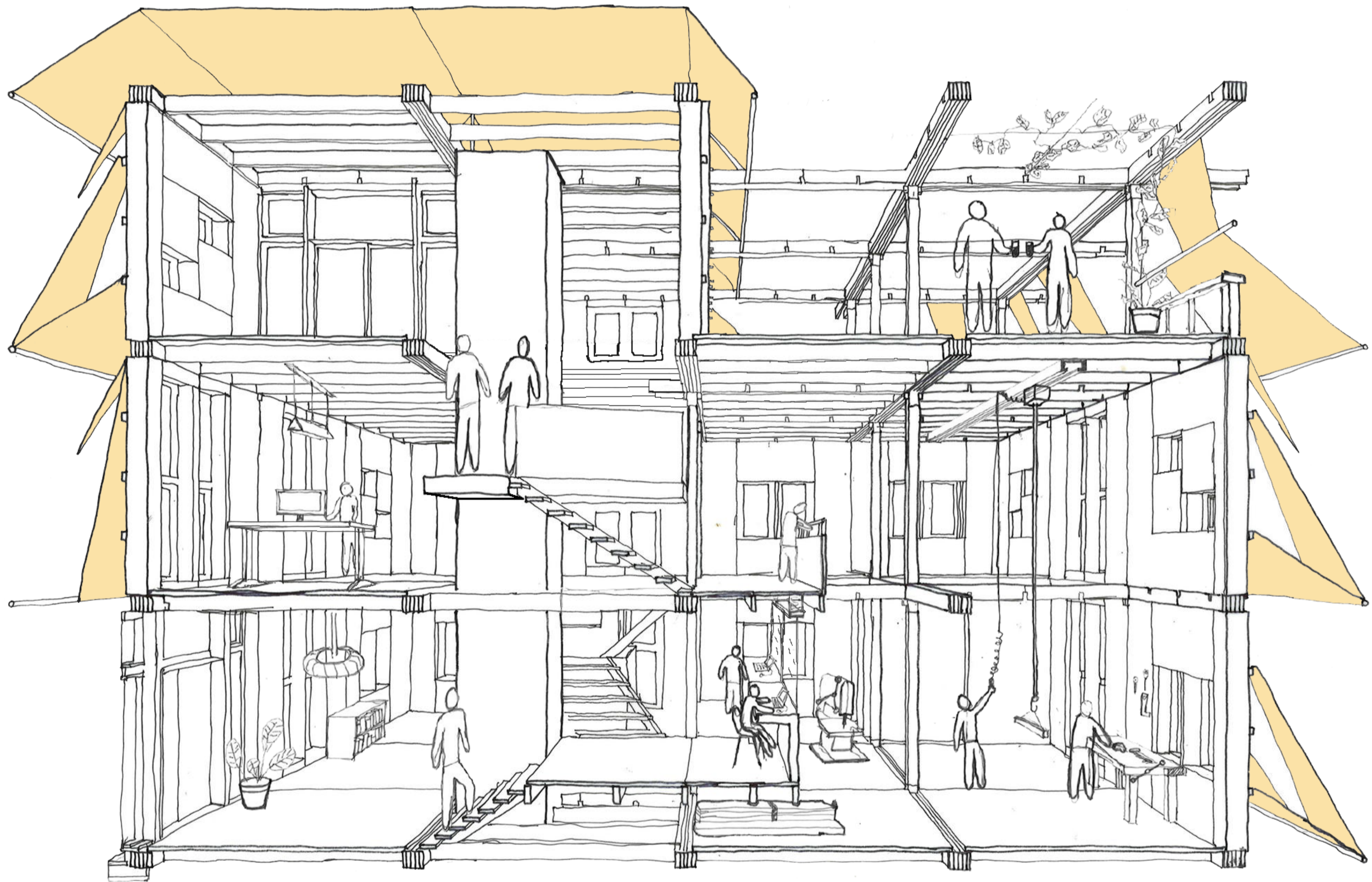

Research

Process

Design

Construction

Housing cooperative Seedpod



Elevation



Research

Process

Design

Construction

Housing cooperative Seedpod



1:20 Model

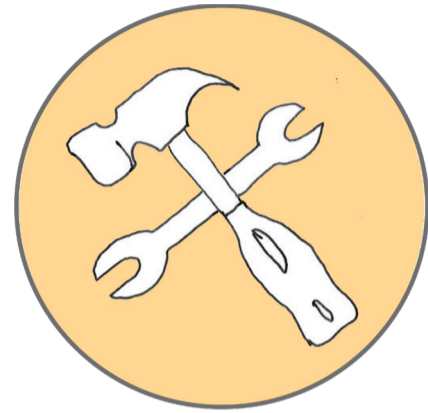

Kit of parts - core
self determined finishing

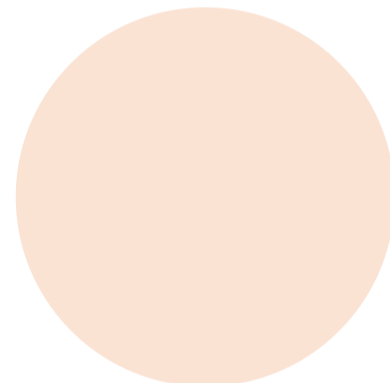
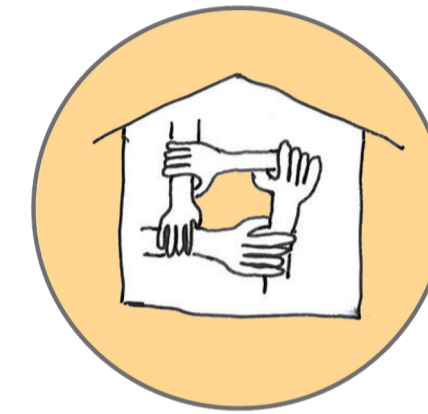

A- All skill levels

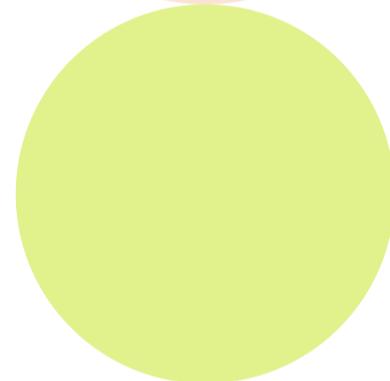

B- Enthusiasts

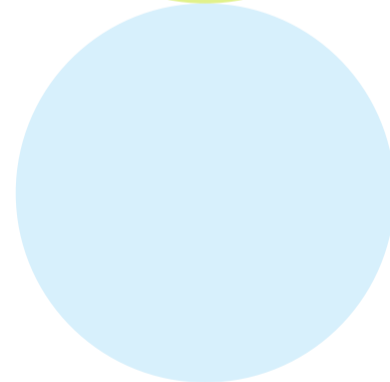

C- Experts



Research

Process

Design

Construction

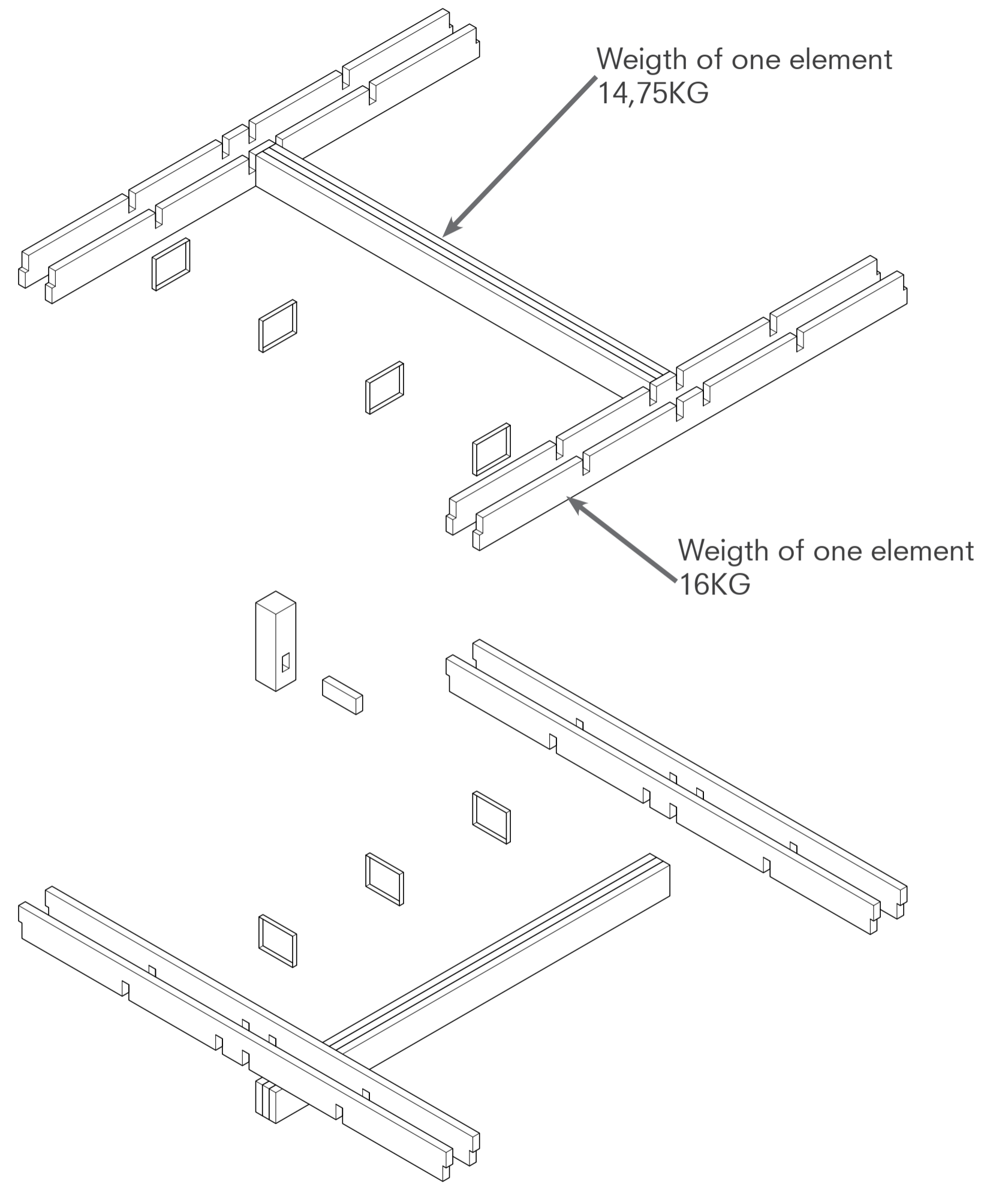
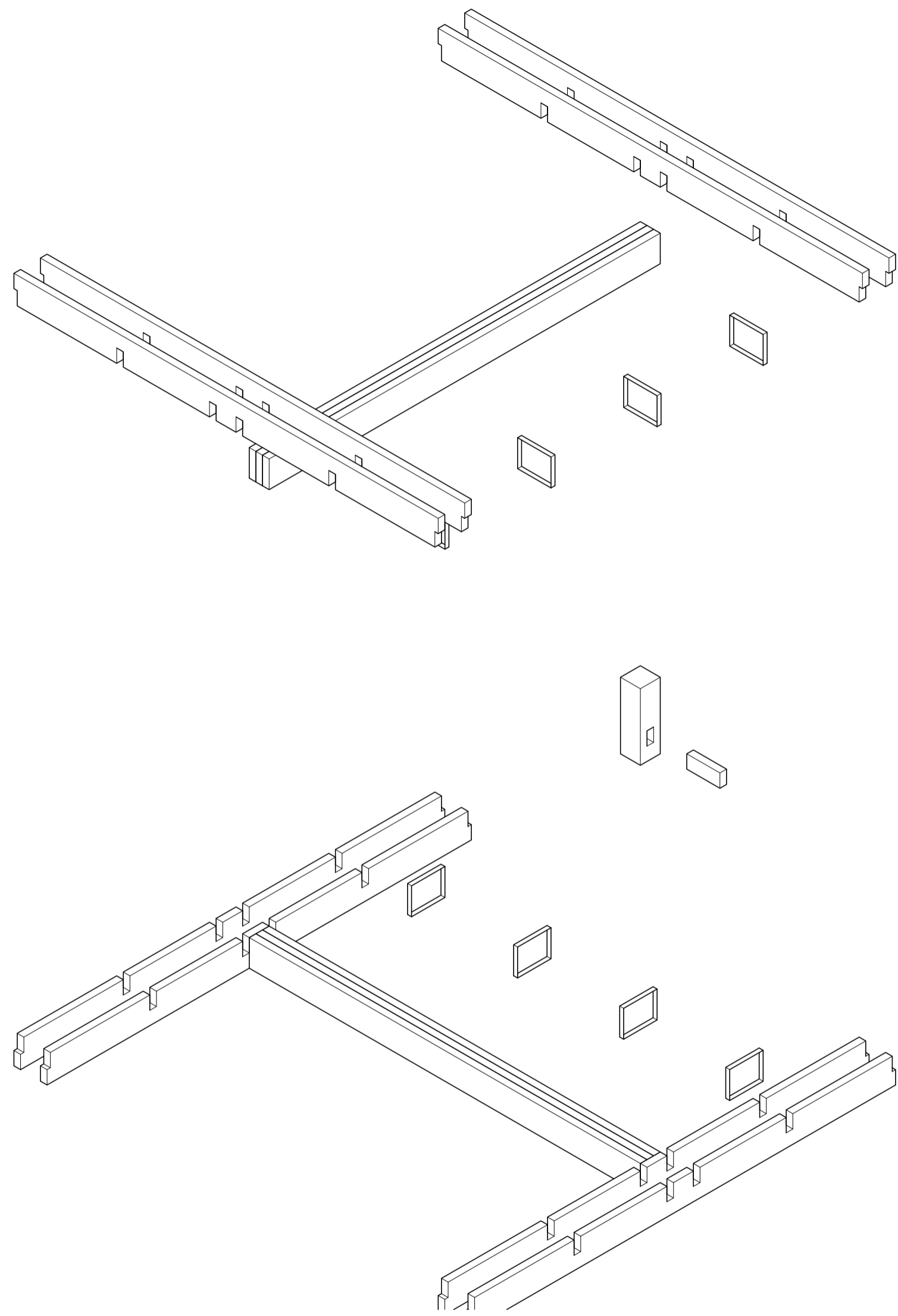

Research

Process

Design

Construction

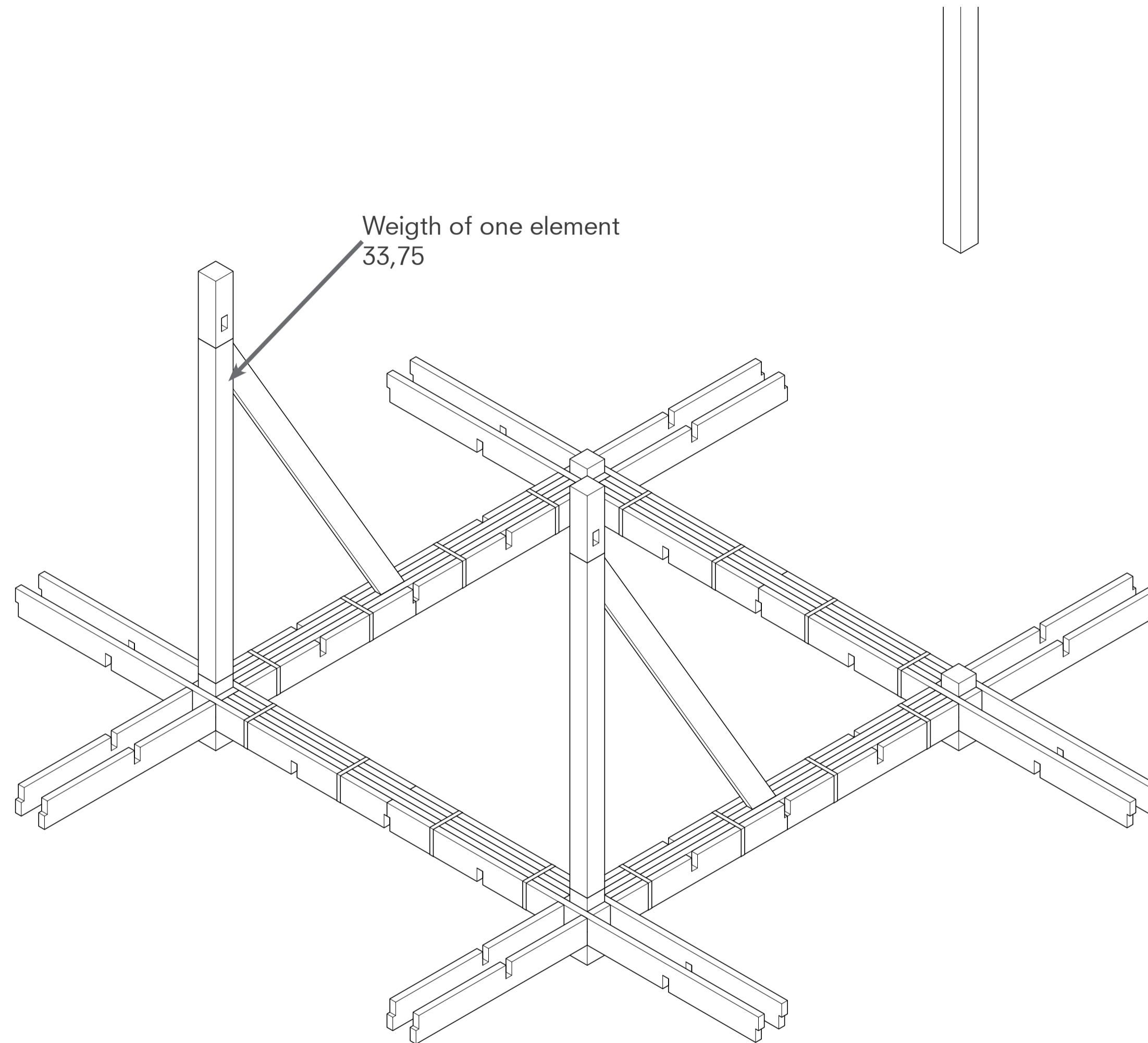

Occupational health and safety advises one person to carry <23KG loads during a work day

Columns need to be transported in a group



Research

Process

Design

Construction

Housing cooperative Seedpod



Construction components



Research

Process

Design

Construction

Housing cooperative Seedpod



1:20 Model

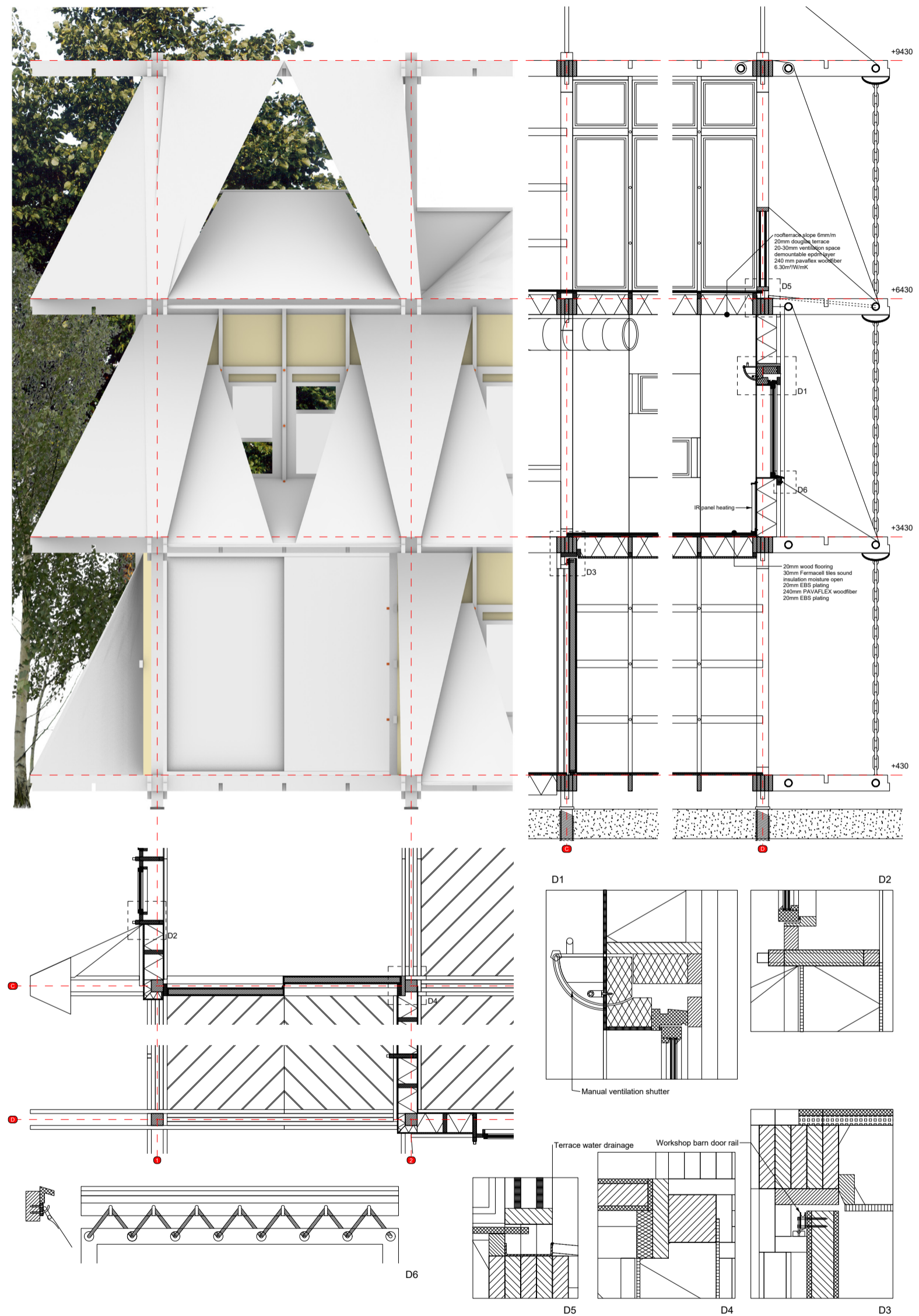

Research

Process

Design

Construction

Housing cooperative Seedpod



Facade fragment

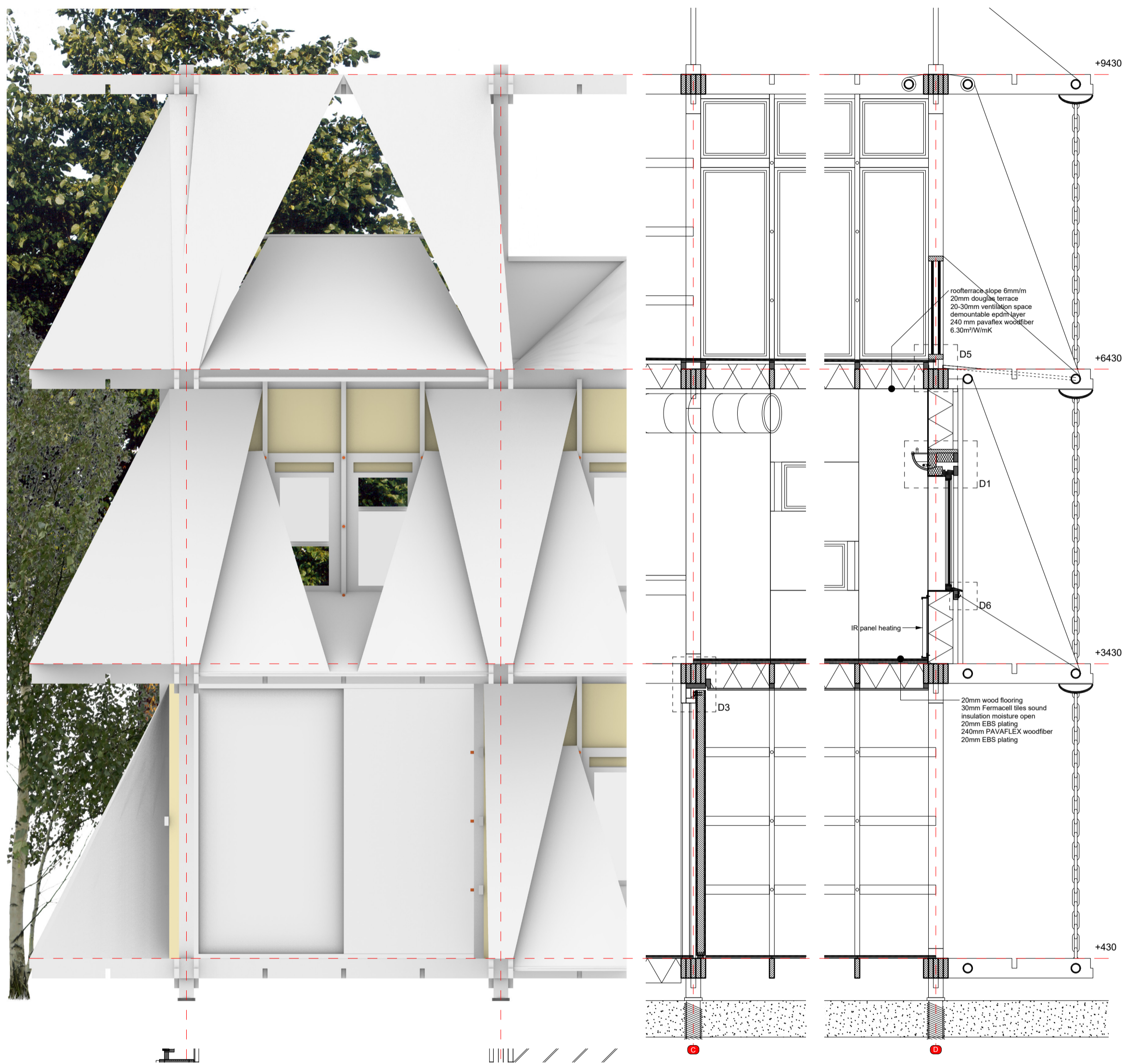

Research

Process

Design

Construction

Housing cooperative Seedpod



Facade fragment

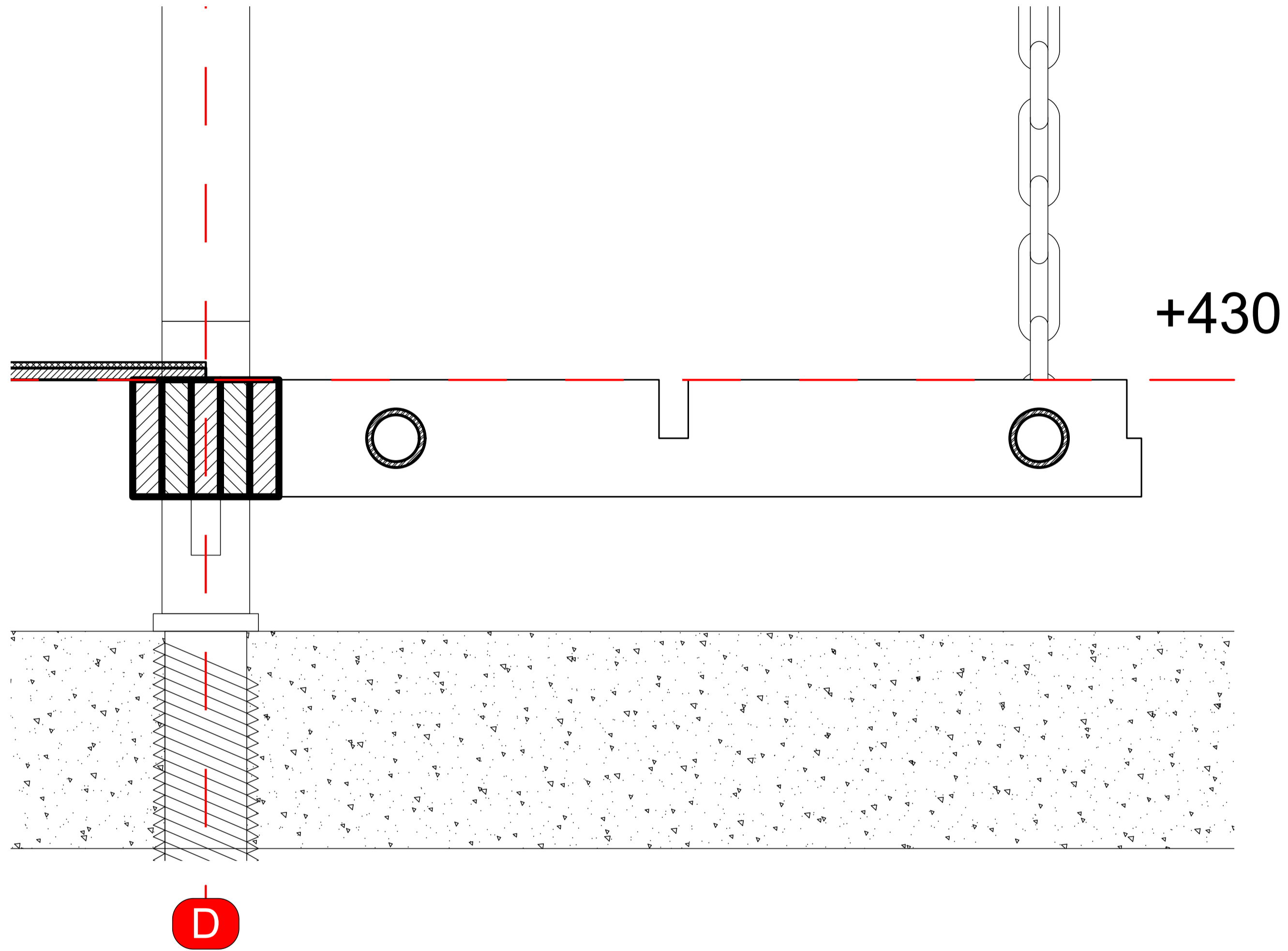

Research

Process

Design

Construction

Housing cooperative Seedpod



Facade fragment

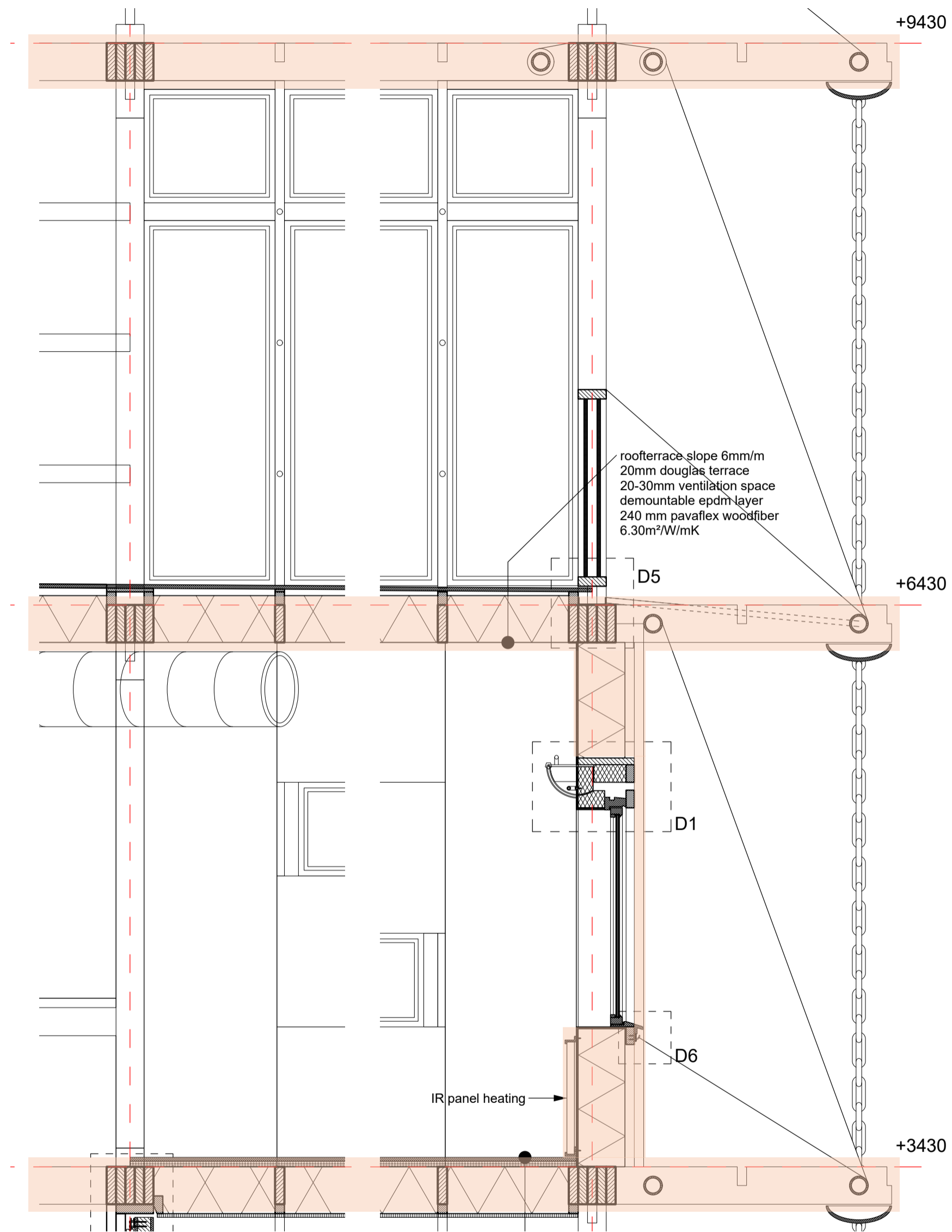

Research

Process

Design

Construction

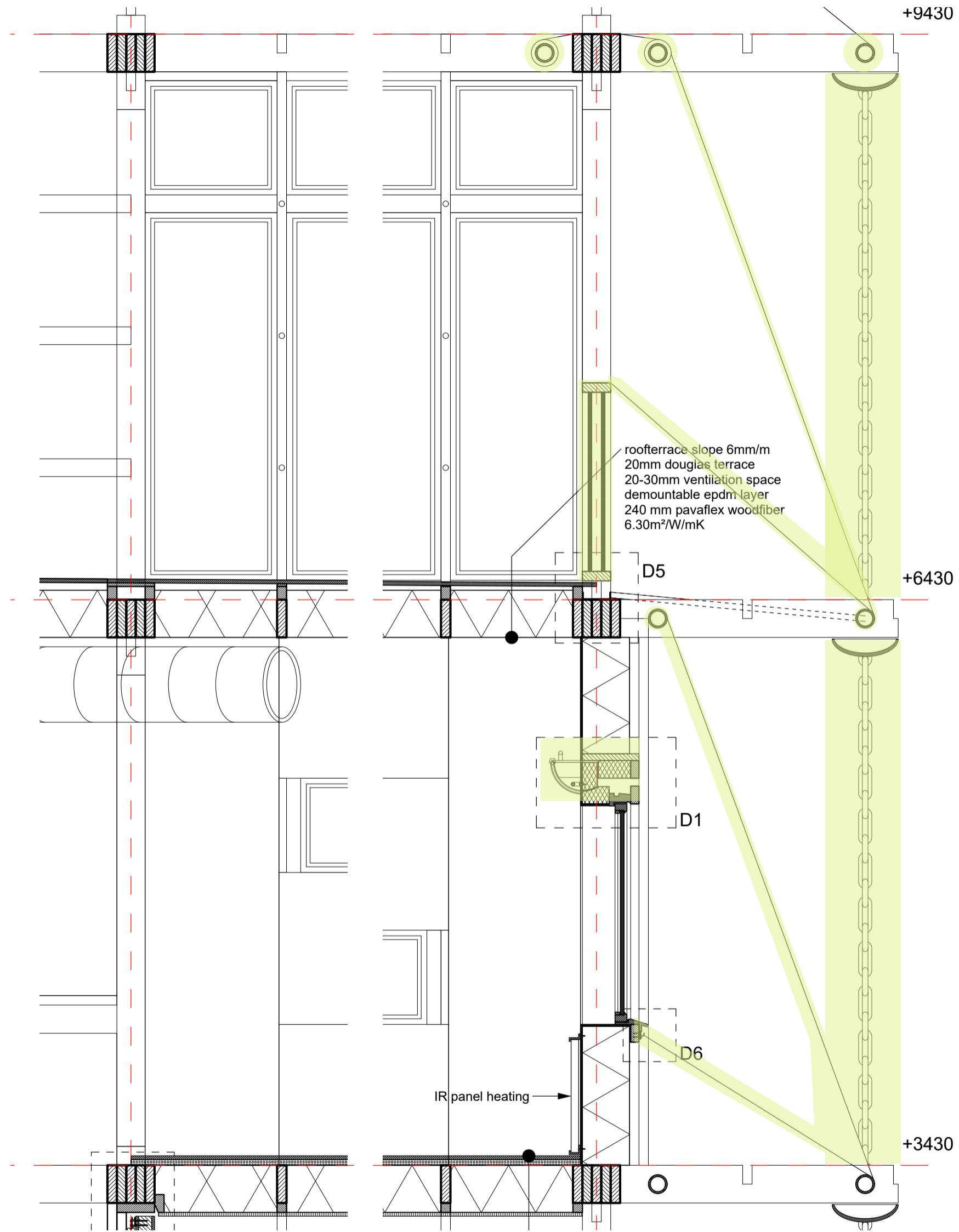

Research

Process

Design

Construction





Research

Process

Design

Construction

Housing cooperative Seedpod



1:20 Model

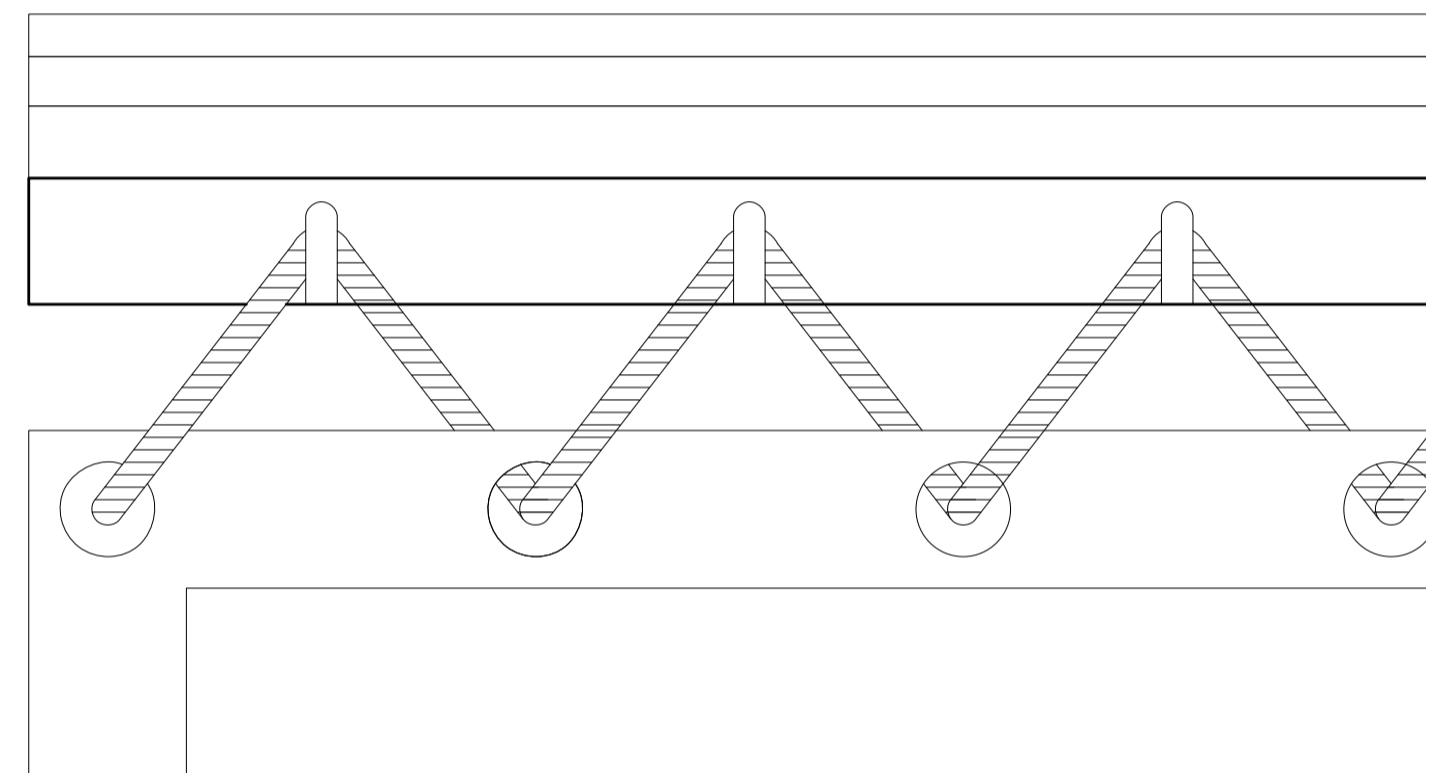
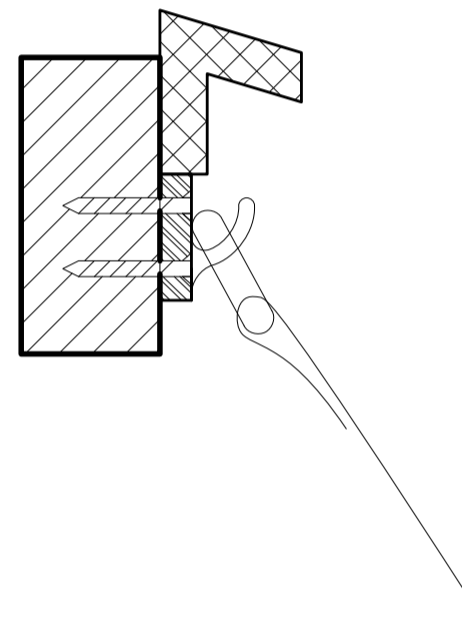
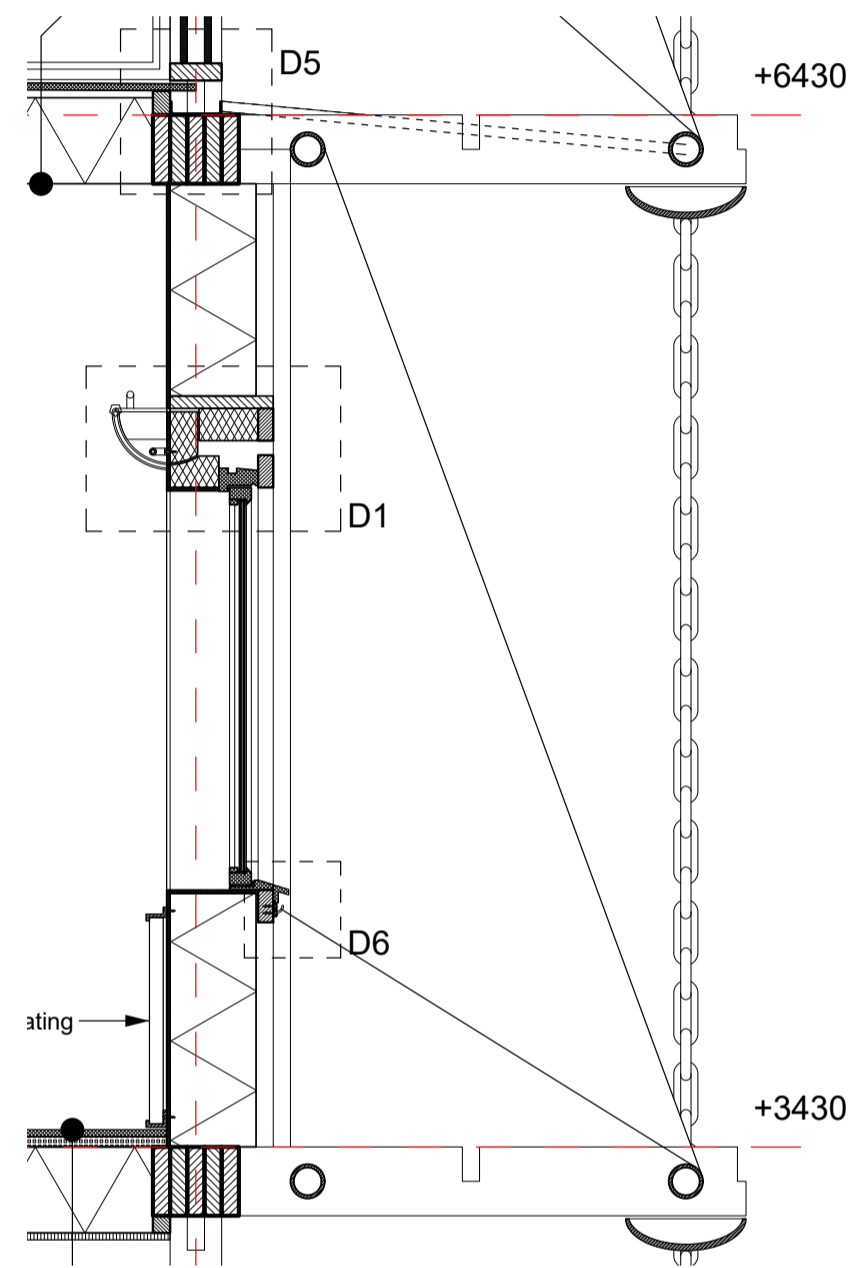

Research

Process

Design

Construction

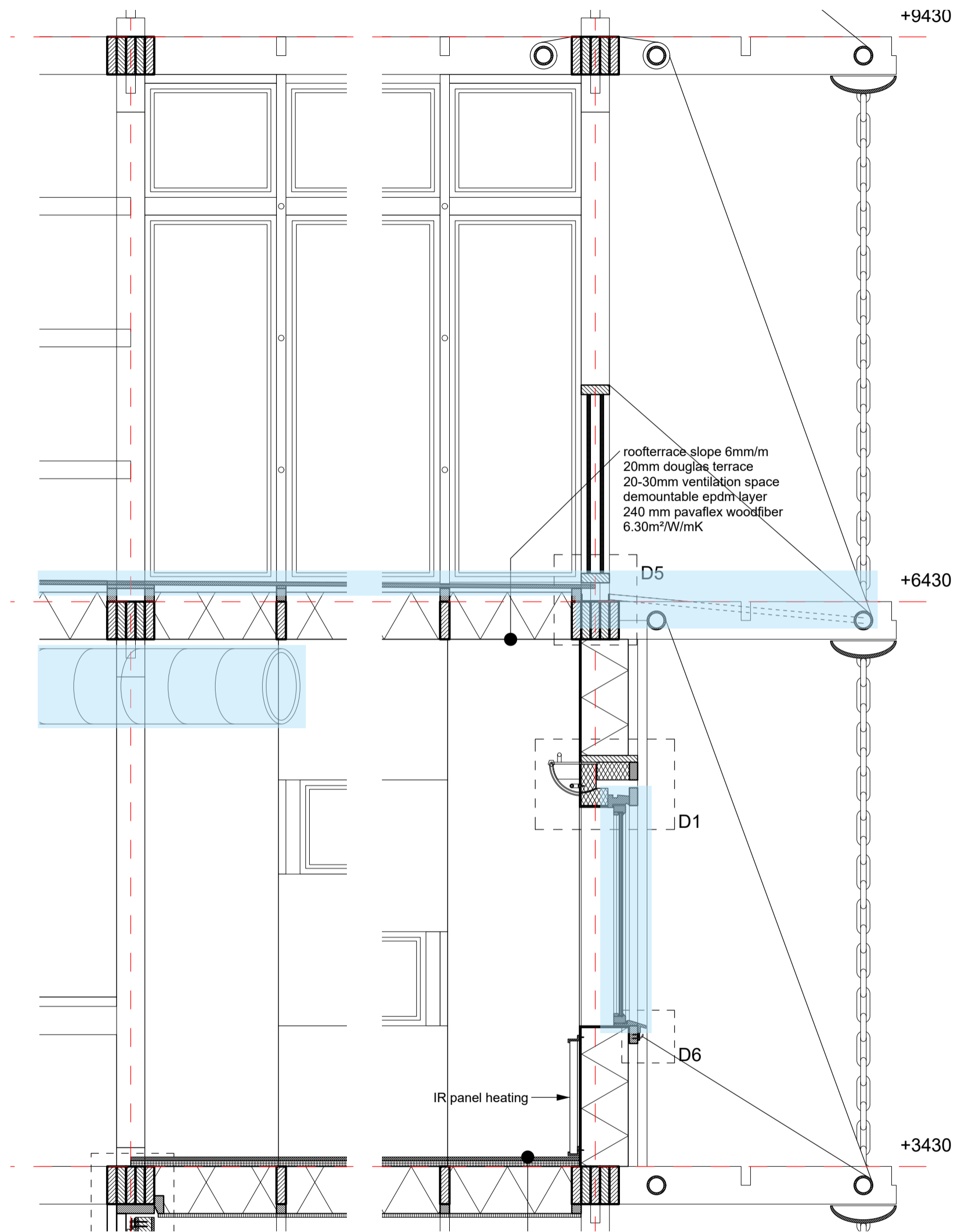

Research

Process

Design

Construction



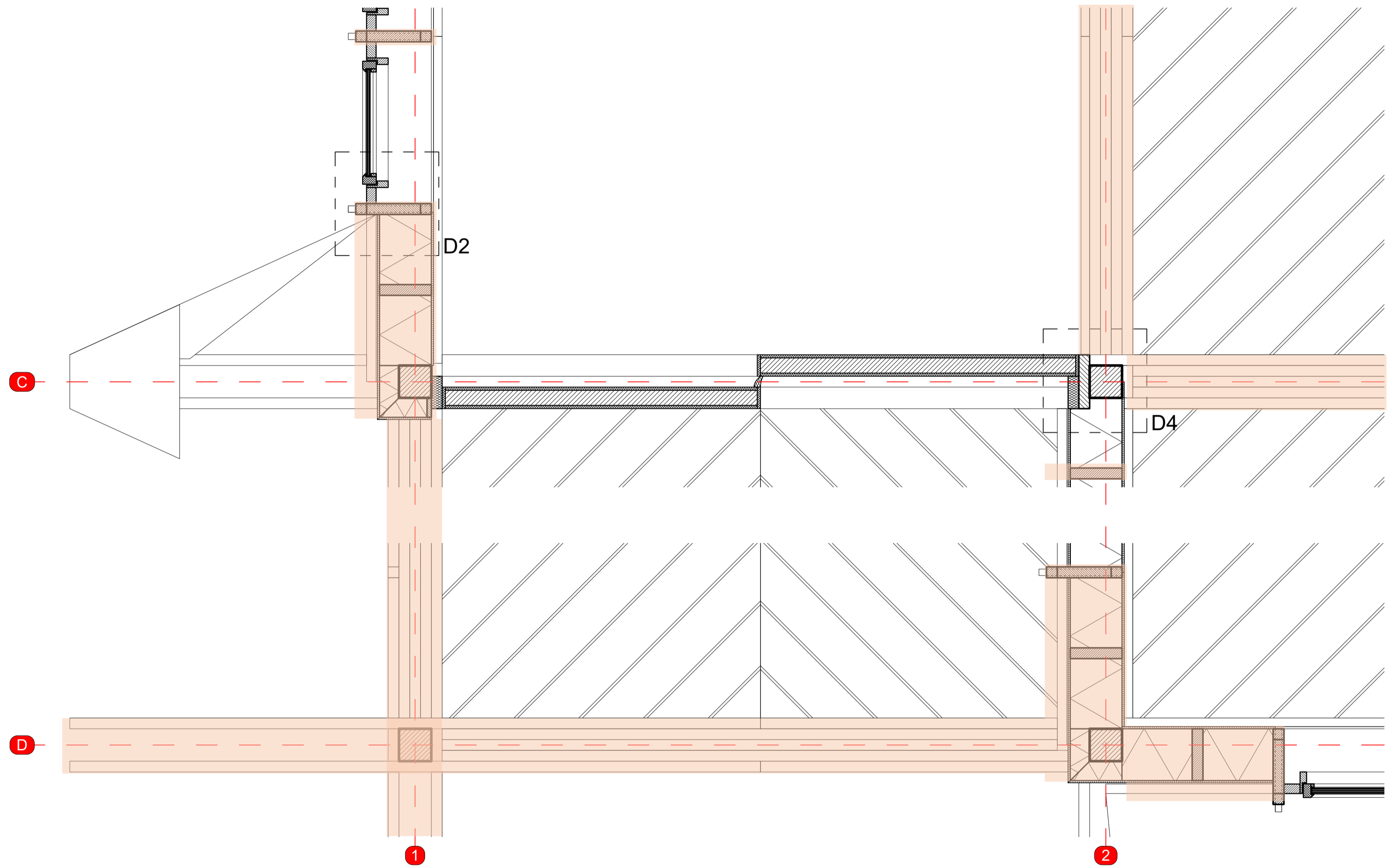

Research

Process

Design

Construction

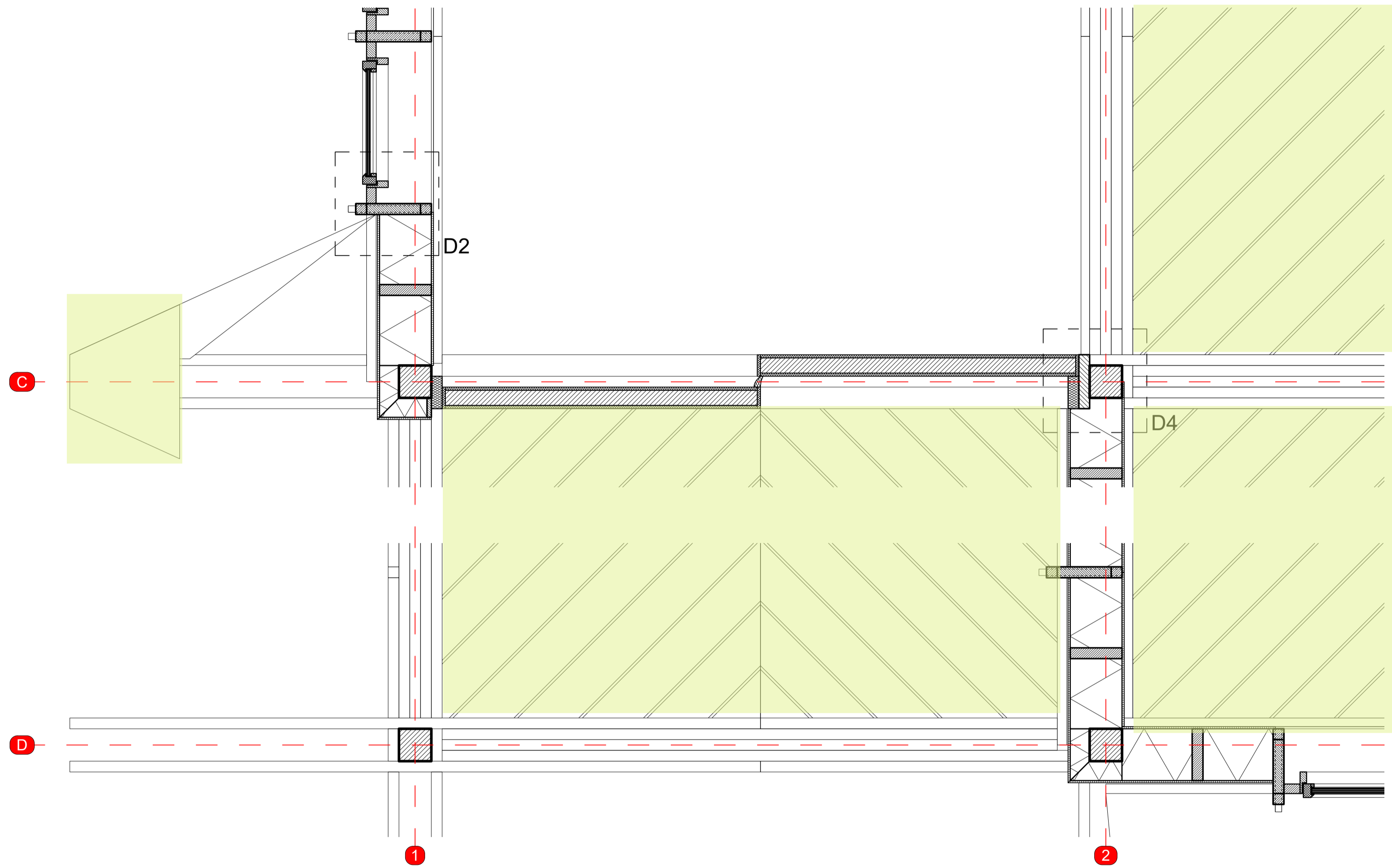

Research

Process

Design

Construction



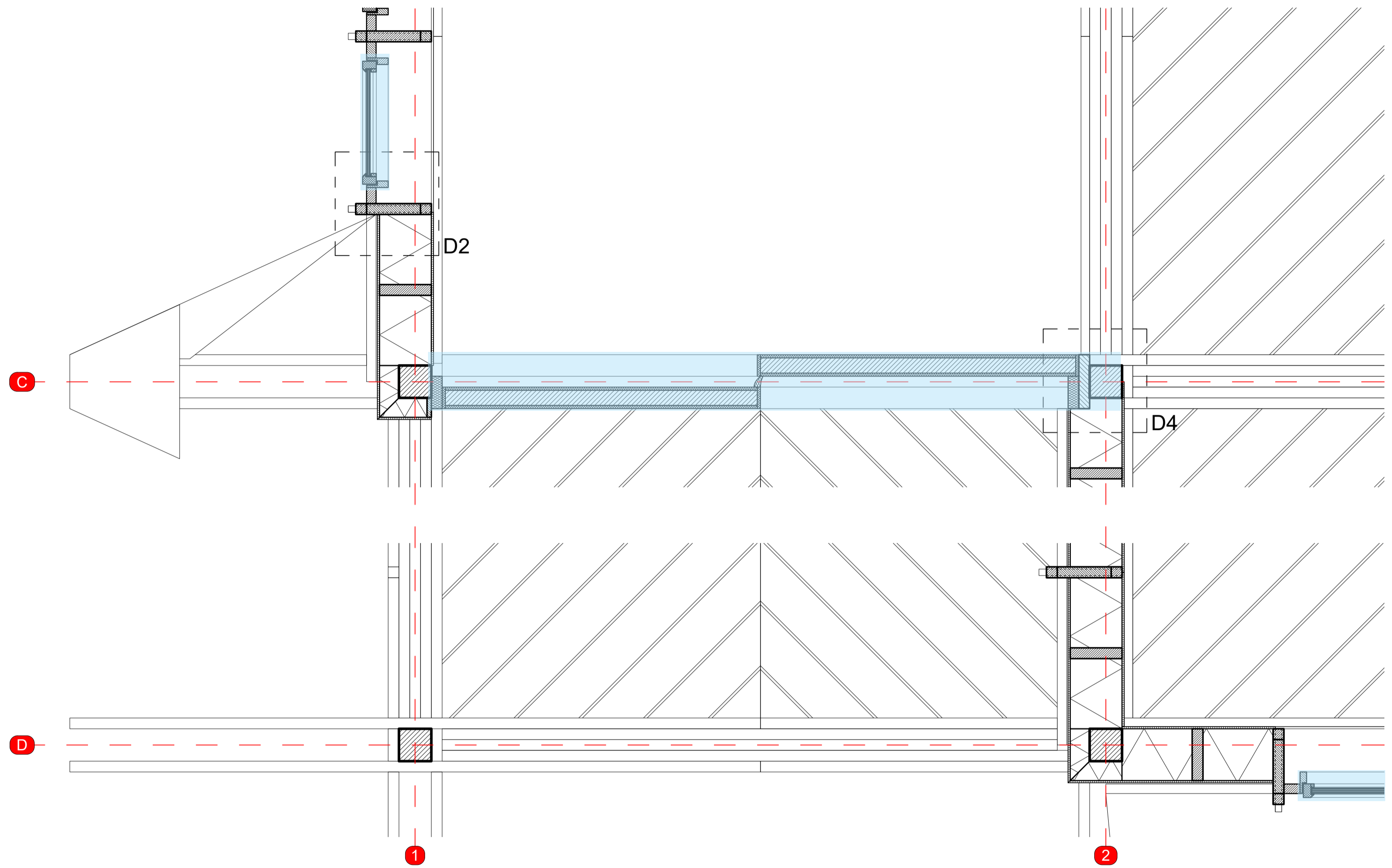

Research

Process

Design

Construction

Housing cooperative Seedpod



Vertical section - C

Research

Process

Design

Construction

Housing cooperative Seedpod



Animation construction

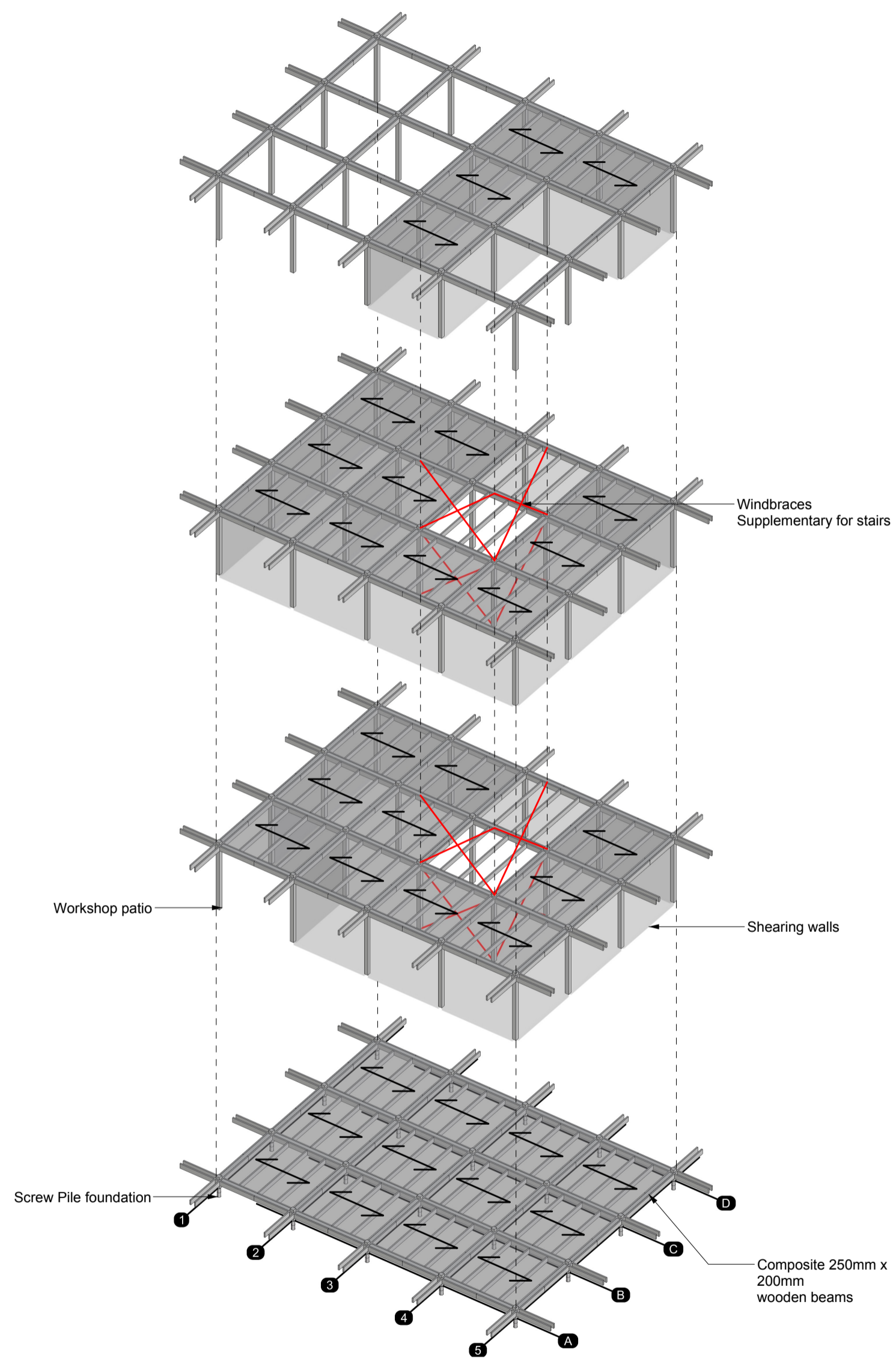

Research

Process

Design

Construction

Housing cooperative Seedpod



Load-bearing structure

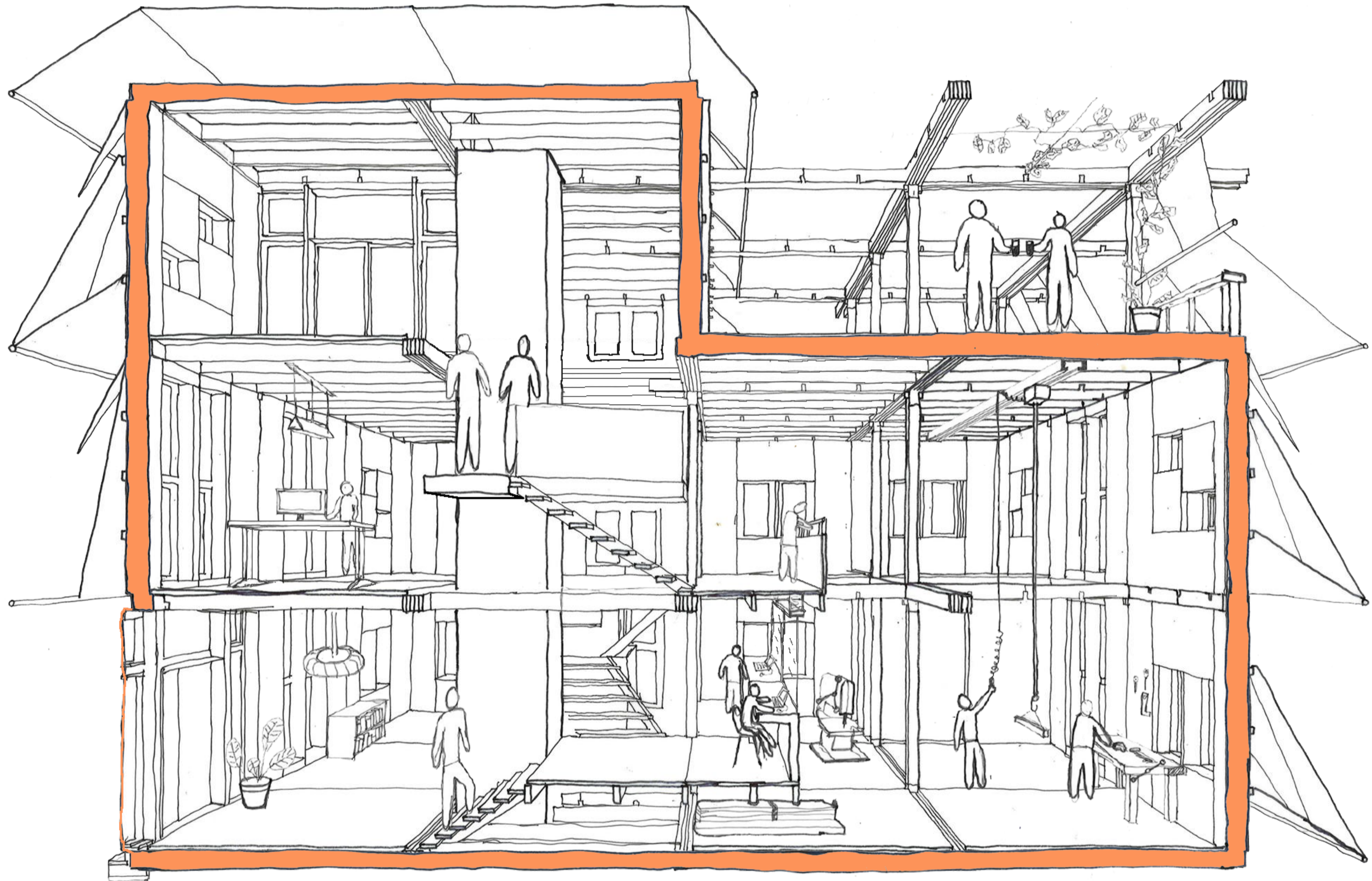

Research

Process

Design

Construction

Housing cooperative Seedpod



Thermal shell

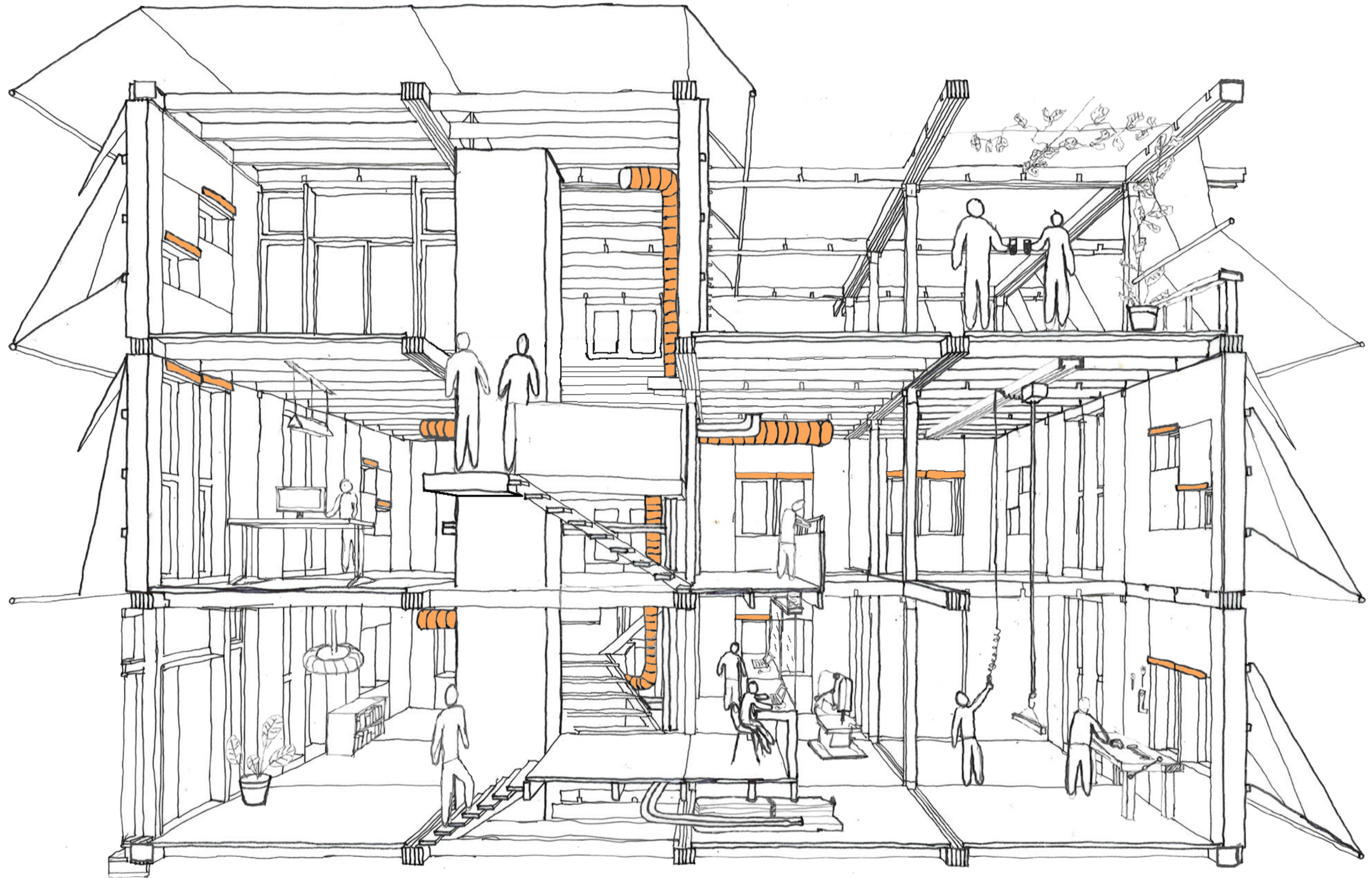

Research

Process

Design

Construction

Housing cooperative Seedpod



Ventilation

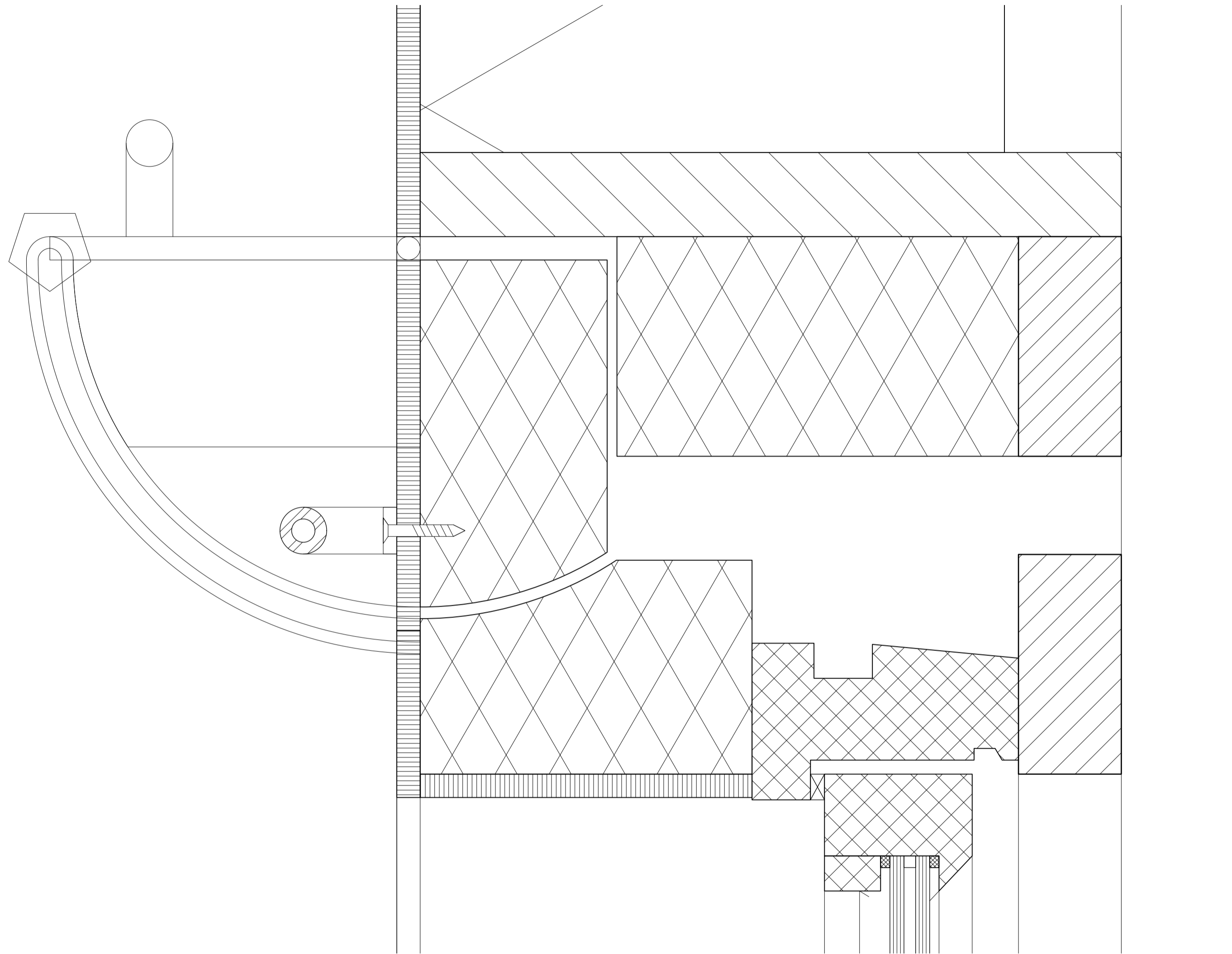

Research

Process

Design

Construction

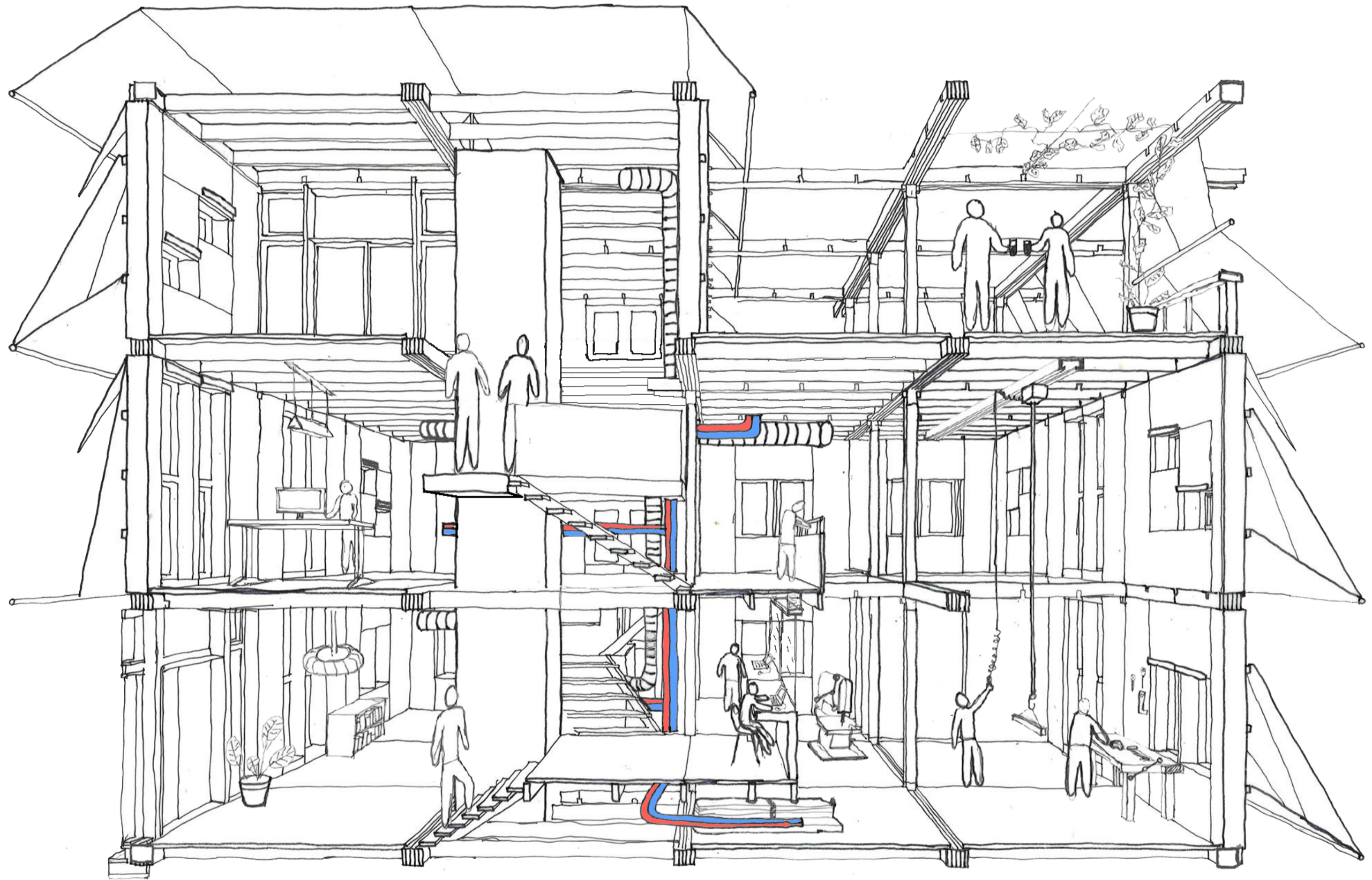

Research

Process

Design

Construction

Housing cooperative Seedpod



Water transport

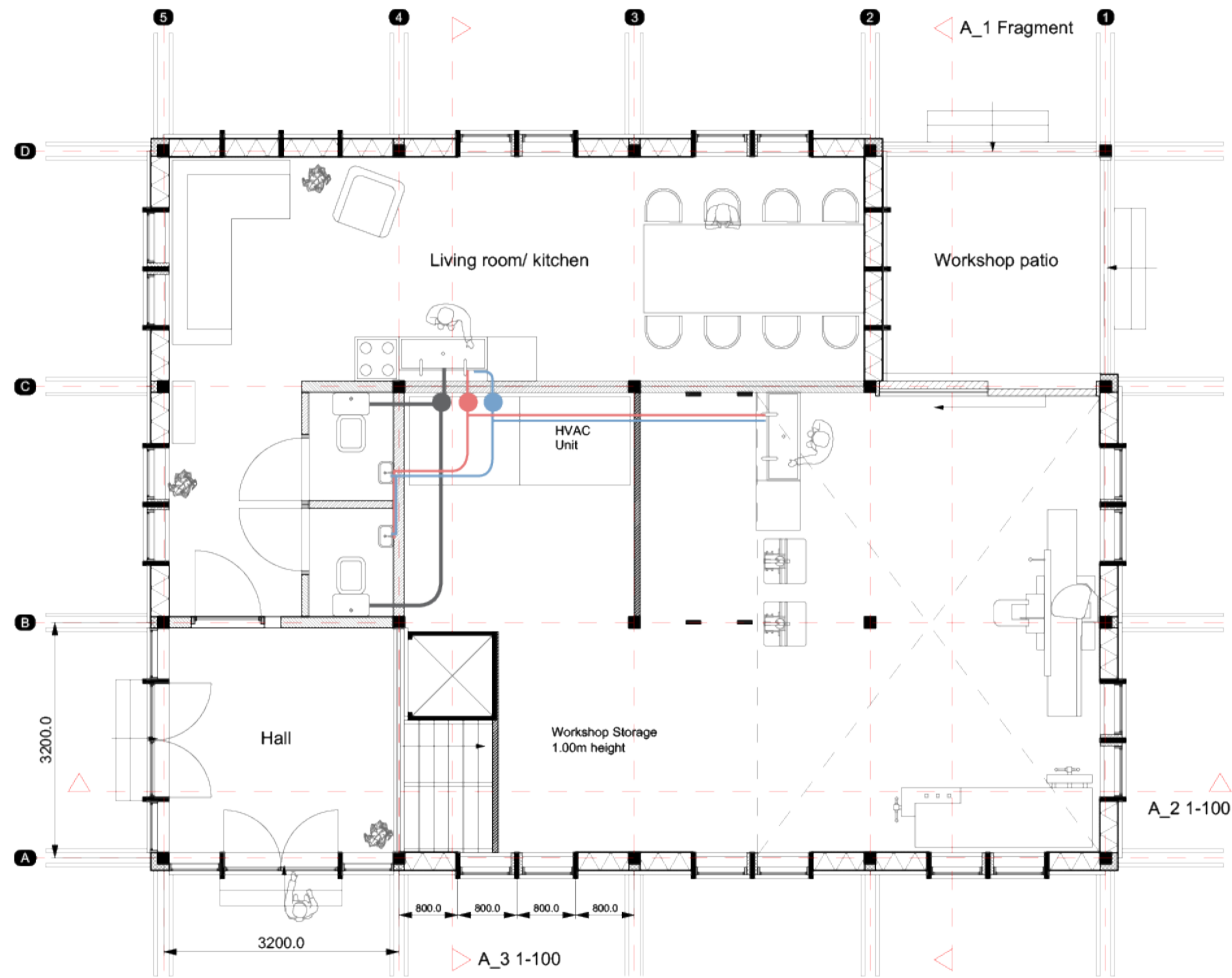

1:50 Ground floor ↗

Research

Process

Design

Construction

Housing cooperative Seedpod



Water transport

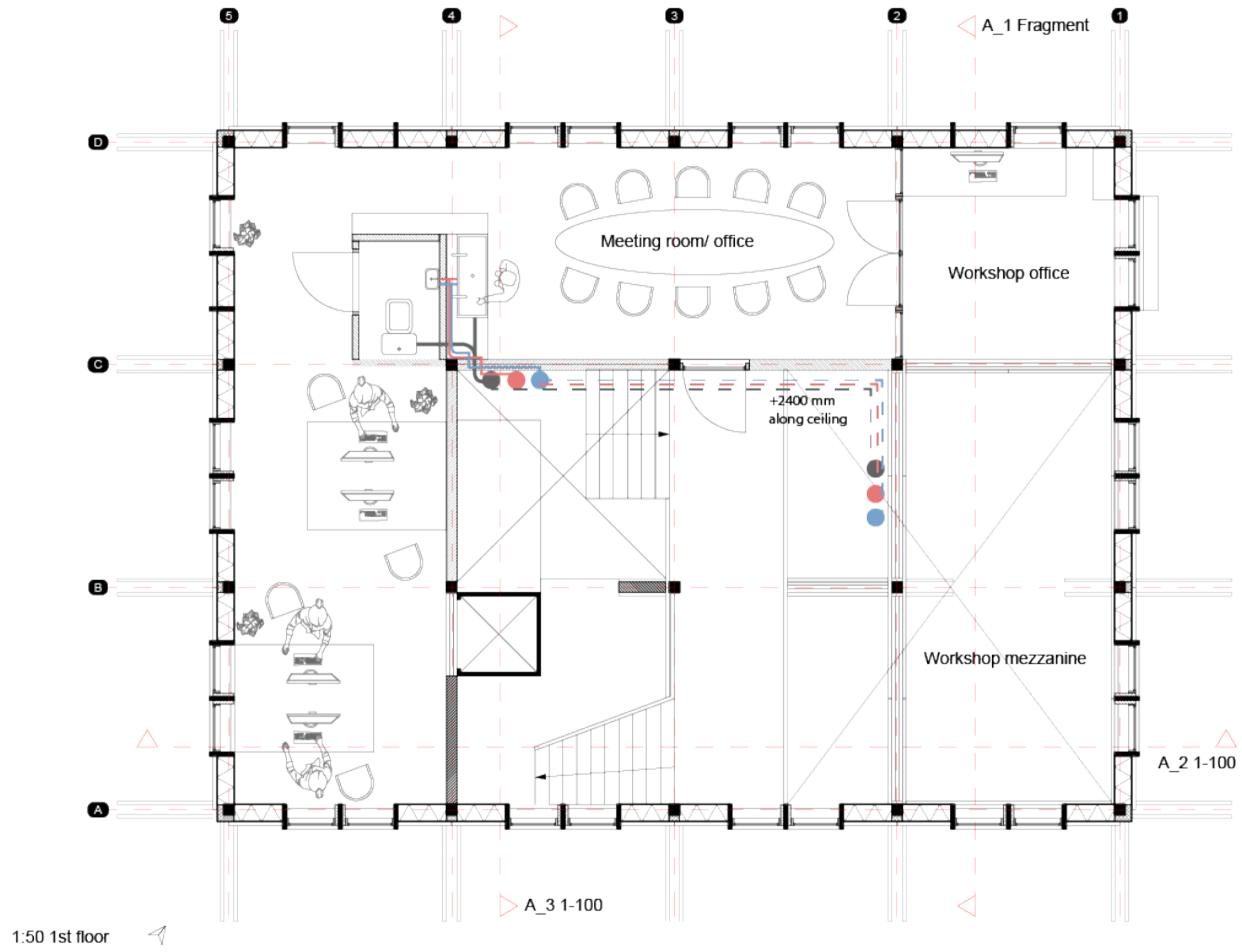

Research

Process

Design

Construction

Housing cooperative Seedpod



Water transport

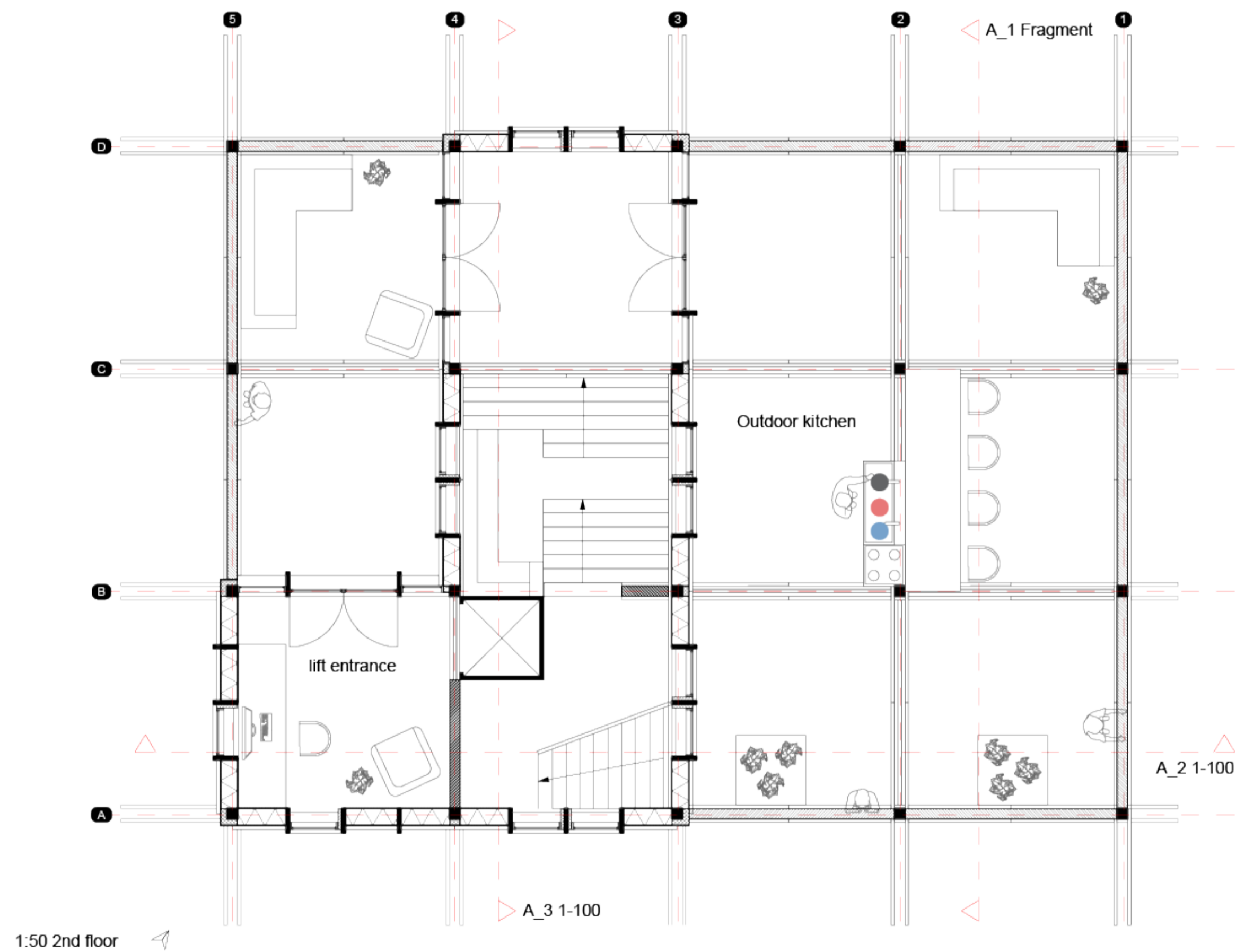

Research

Process

Design

Construction

Housing cooperative Seedpod



Water transport



Research

Process

Design

Construction

Housing cooperative Seedpod



Material application



Research

Process

Design

Construction

Housing cooperative Seedpod



Material application

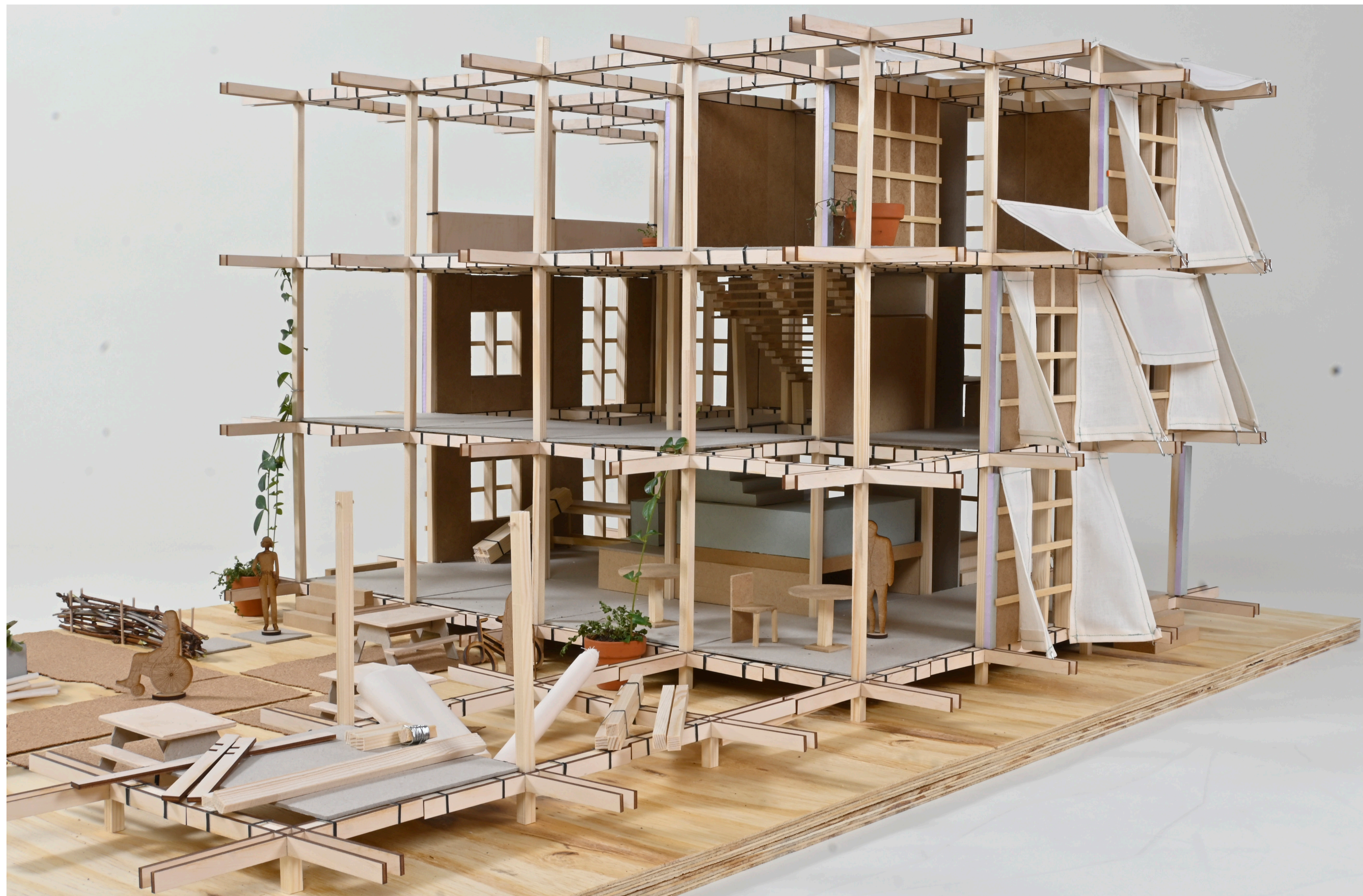

Research

Process

Design

Construction

Housing cooperative Seedpod



1:20 Model

the Cooperative Seedpod

