

1. CONCEPT AND RESEARCH

TBILISI, the capital of Georgia, a country that is part of the "One Belt, One Road" initiative or most commonly referred to as "The New Silk Road" is an urban scenario in which multiple transformations and mutations are constantly happening in the built environment. The most fascinating aspect of this city is without a doubt the ability its habitants have to adapt their surroundings to their daily needs by the use of improvised, spontaneous and instinctive methods which reflect the most crude and essential aspect of their reality. To comprehend the true nature of these changes, and as part of a research for a potential architectural project, a series of drawings was produced which consisted on the documentation of various situations in the city in which the mentioned transformations and mutations had taken place. These transformations are the result of either the pass of time and abandonment or the urban or social need to adapt an existing element into something new. This investigation was divided into three parts which are based on a series of photographs taken on site. The first one is the representation of particular transformations which are isolated from its surroundings and are treated as components of something bigger. The second part consists on the assemblage of these components in order to understand how they are connected with each other conforming a bigger element. Finally, the last part is a re-ordering of the components to create a re-assemblage between them resulting in the creation of new and unexpected compositions and situations. The following are two examples of this investigation procedure.

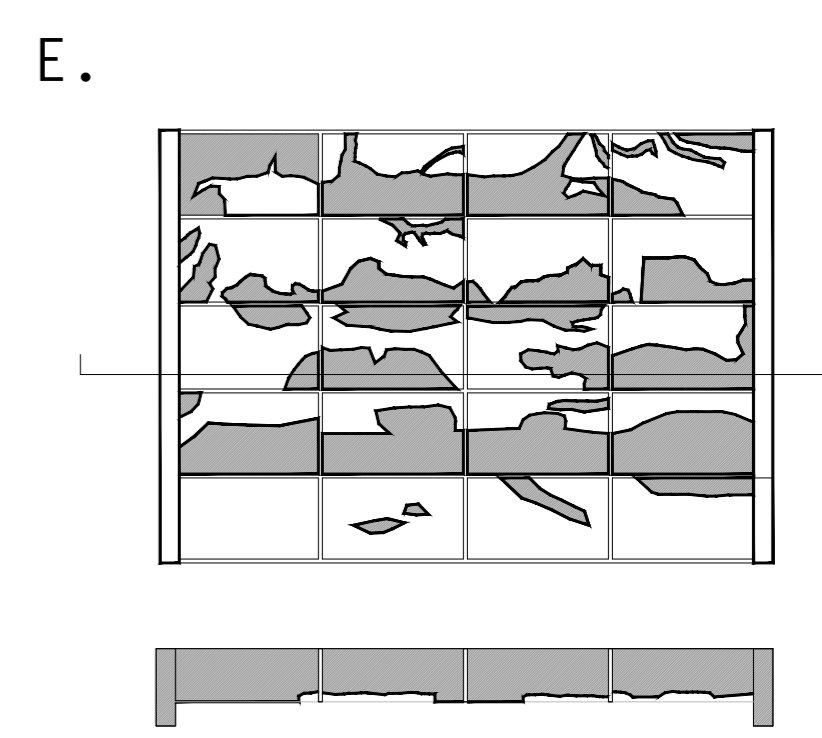

ASSEMBLAGE

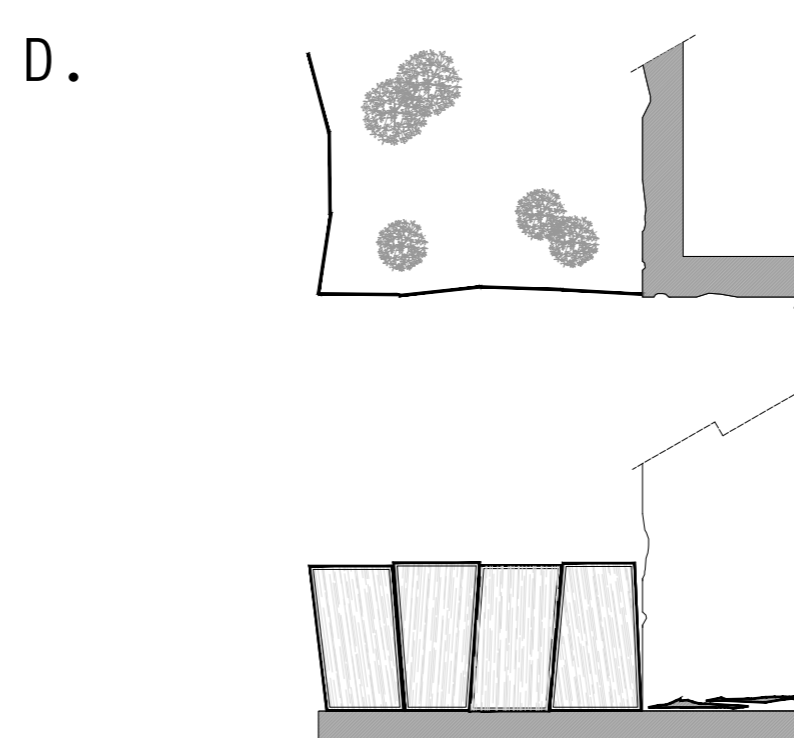
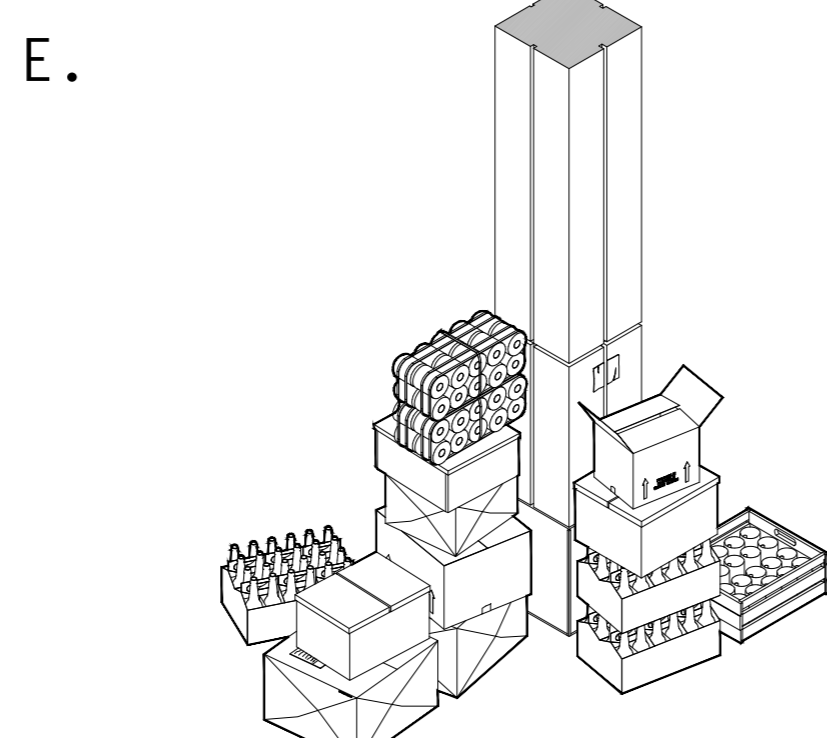
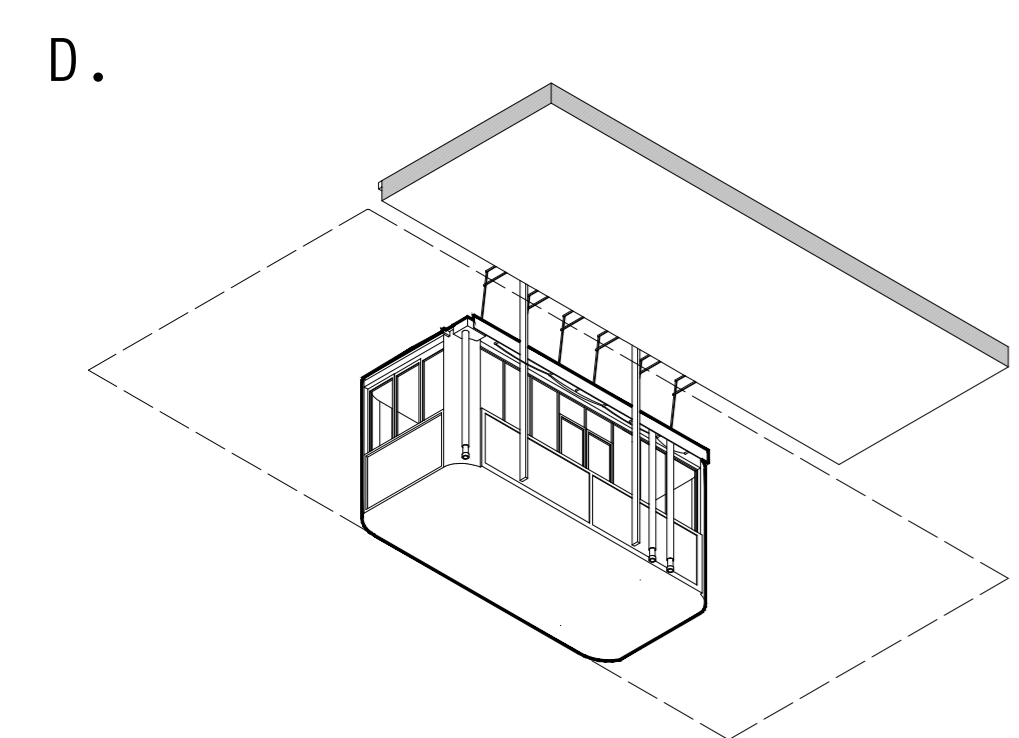
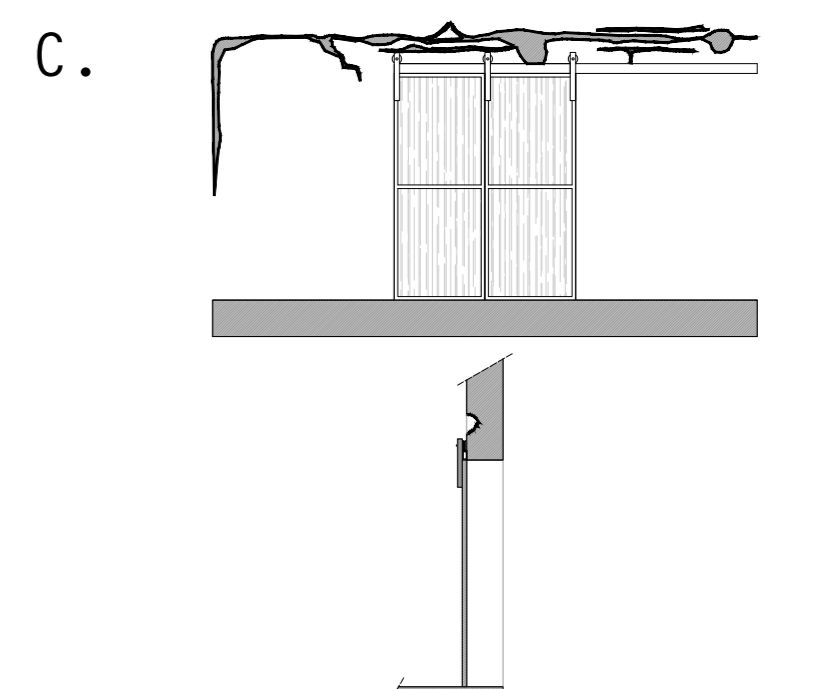
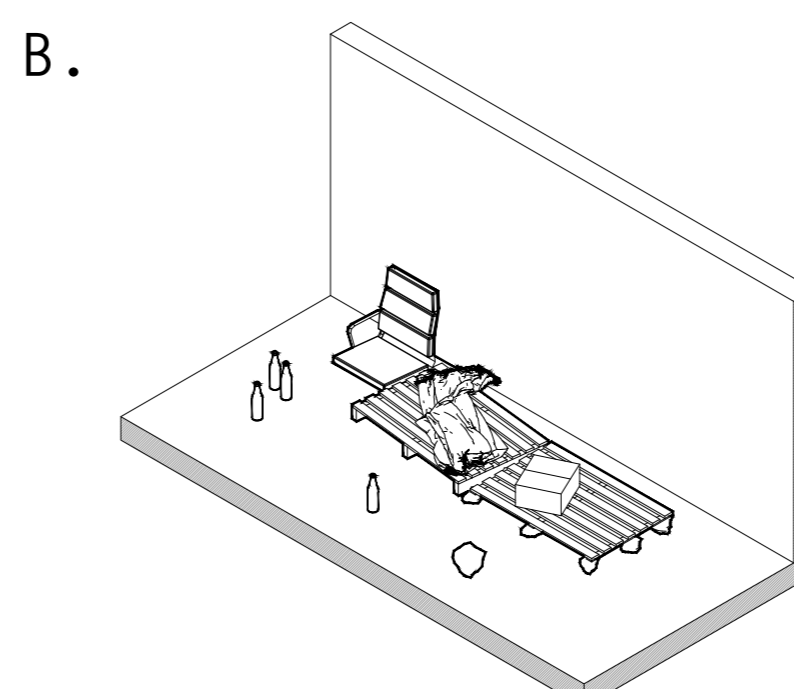
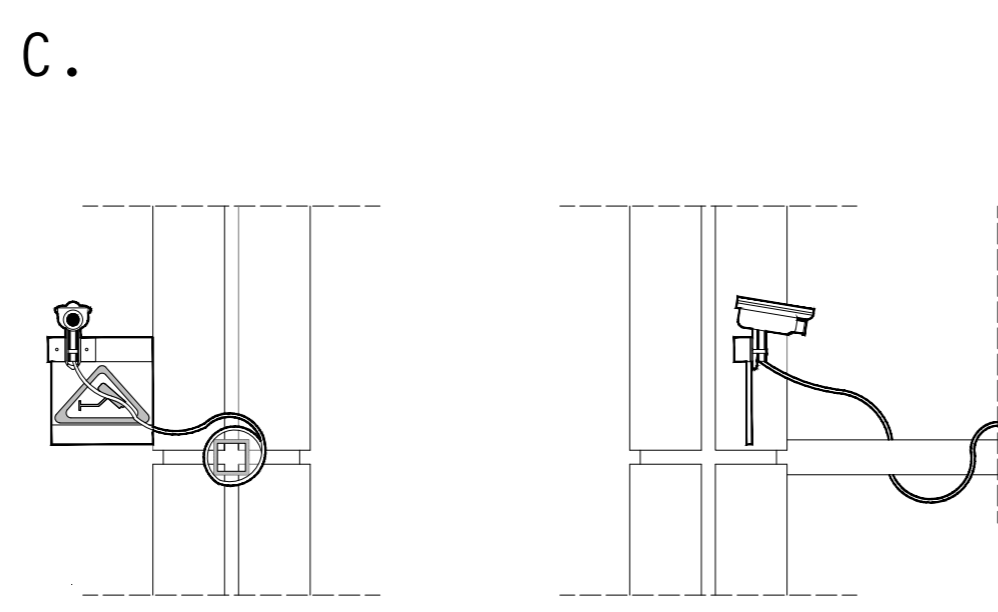
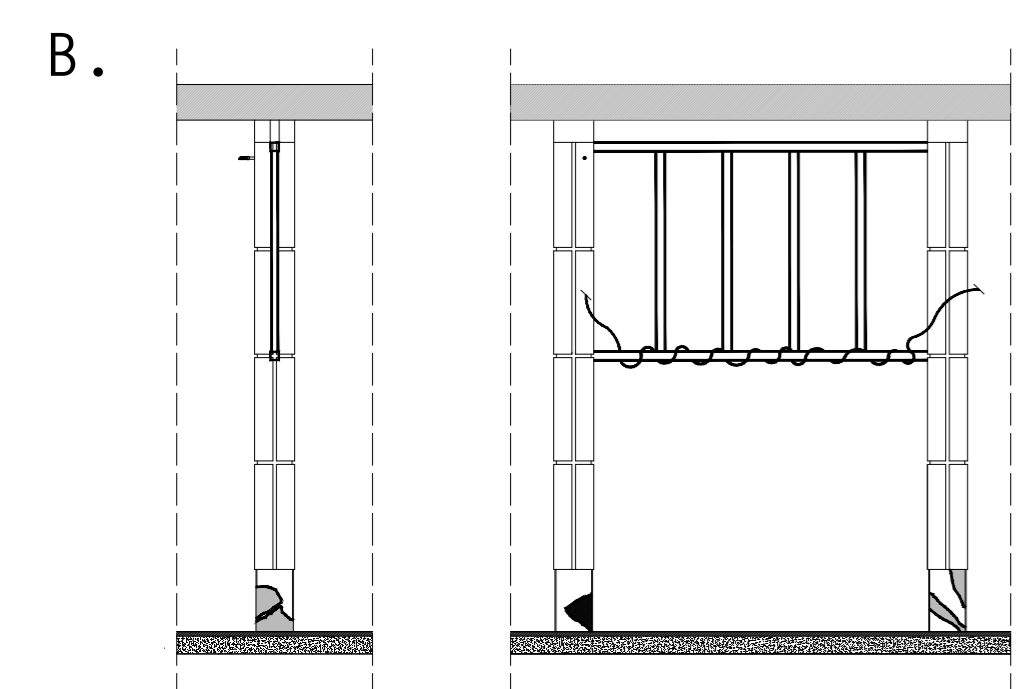
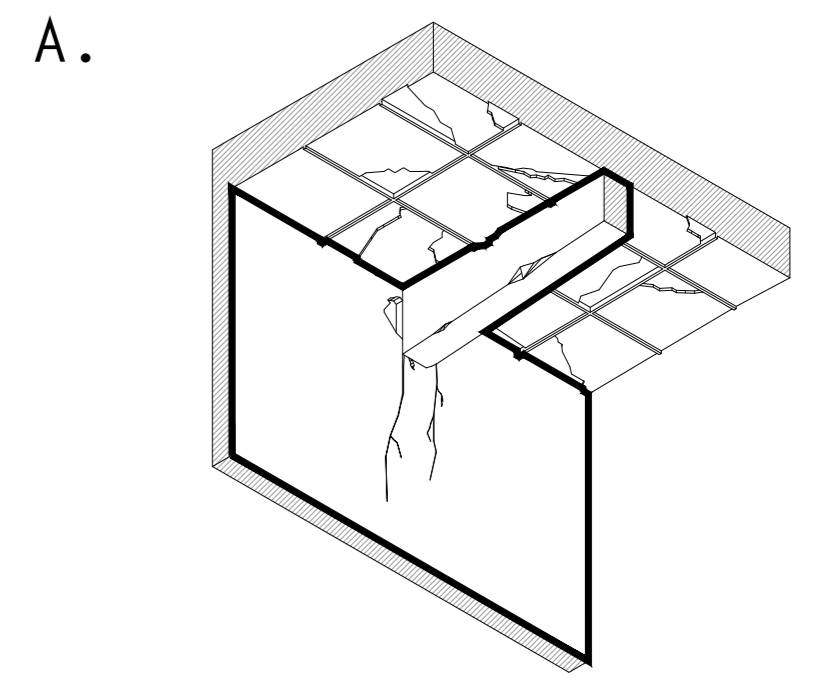
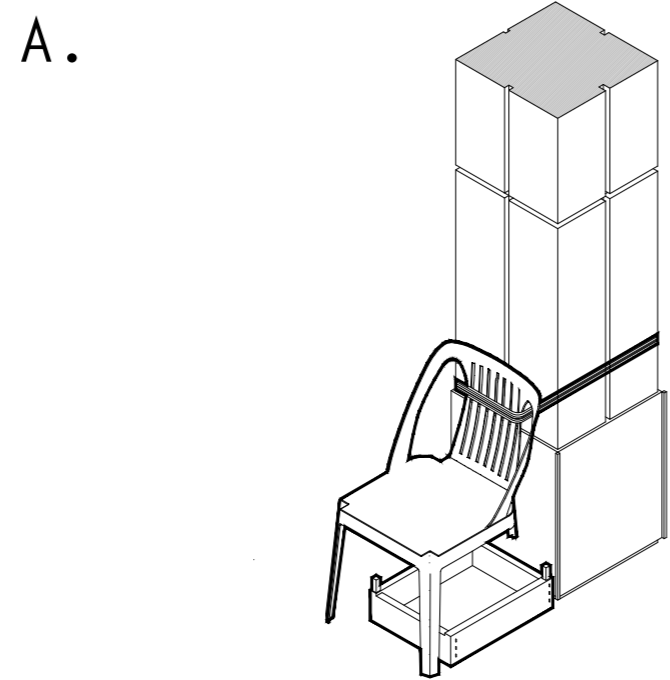
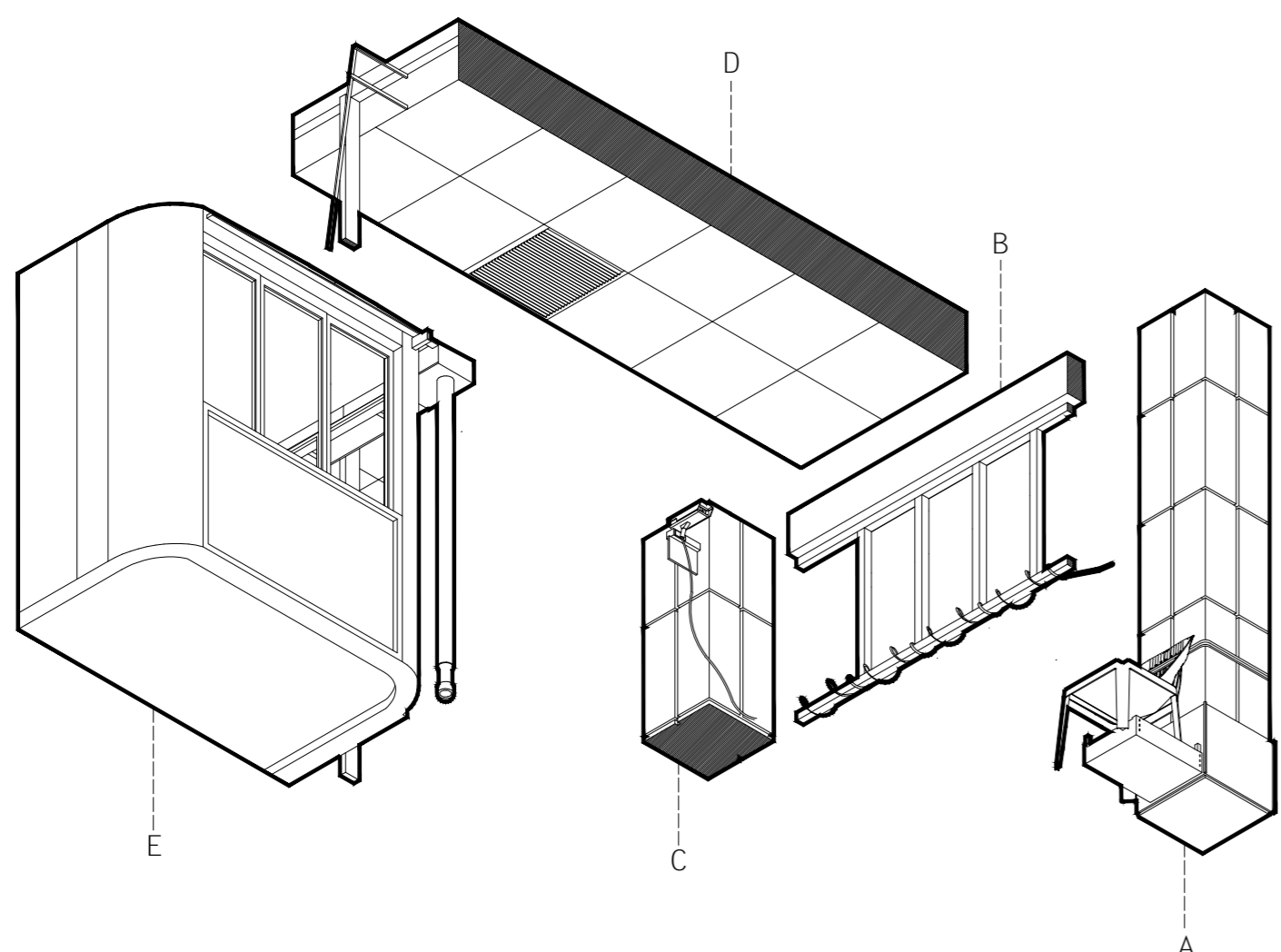

ASSEMBLAGE

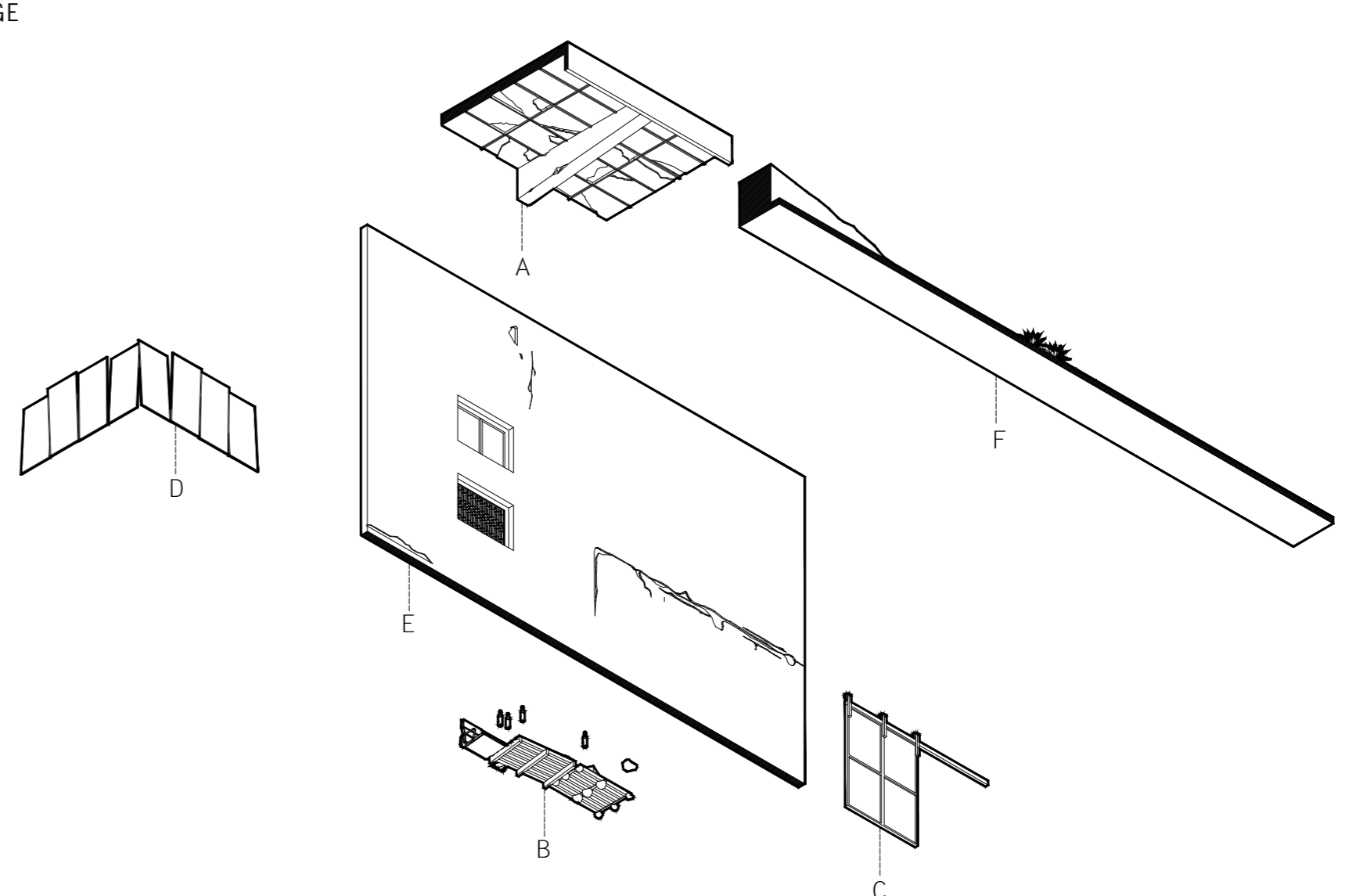

RE-ASSEMBLAGE

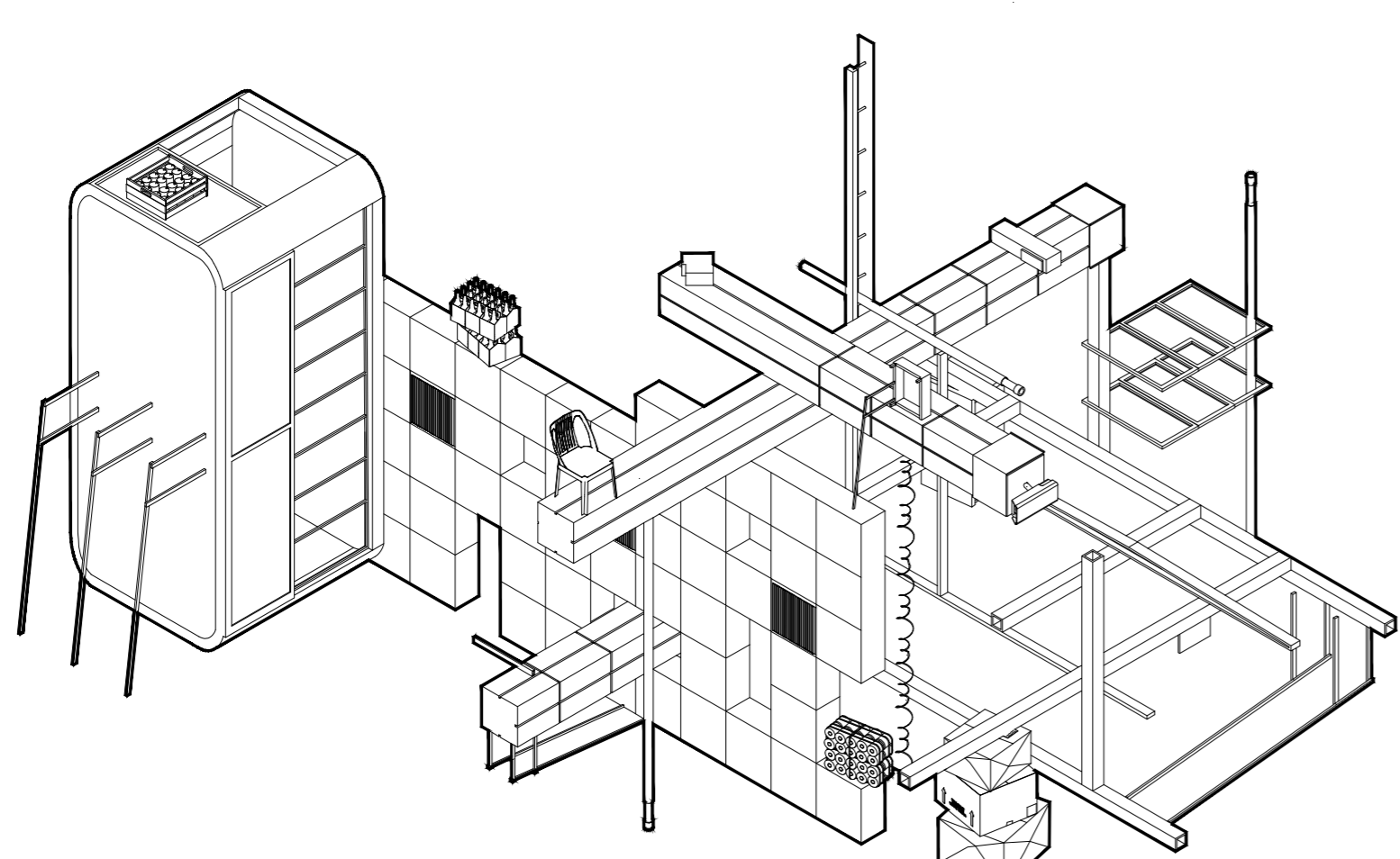

RE-ASSEMBLAGE

