

MUSICAL BINCKCROSS

Shing Yat Tam Samuel

AR3AP100 | MSc3 | Public Building Graduation Studio

Music Marvel | Music & Popular Culture Re-Wired

P5 Presentation | 15-06-2022



**“Music is liquid architecture;
Architecture is frozen music.”**



Johann Wolfgang von Goethe

PROBLEM

ON TYPOLOGY

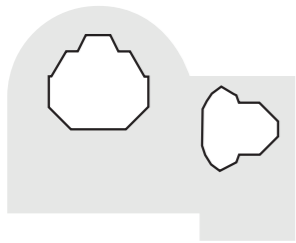

Philharmonie de Paris

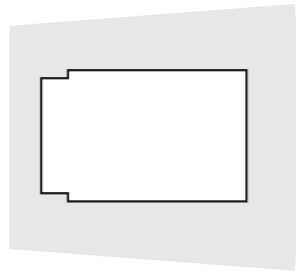

Royal Festival Hall

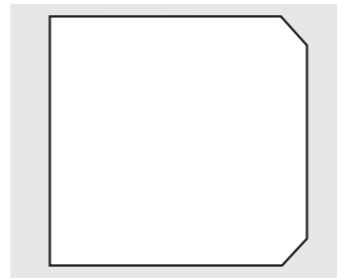

Ziggo Dome

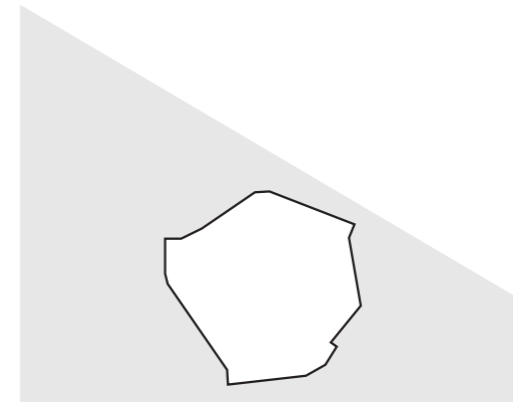

Elbphilharmonie Hamburg

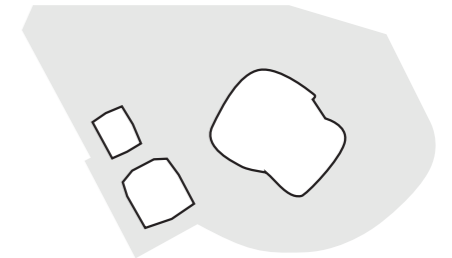

Barbican Centre

Is there a way for us to “defrost” the architectural type and better reflect the fluidity of music in concert halls?

SITE

INDUSTRIAL LAND TO BE REGENERATED



Nederland



Zuid Holland

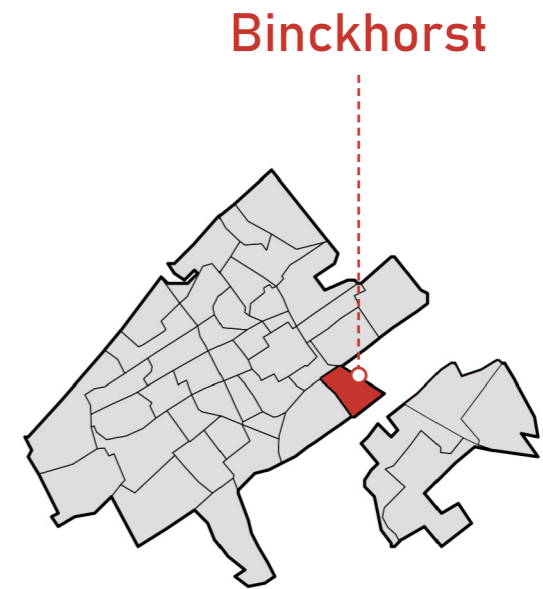

Den Haag

Binckhorst

PROBLEM

ON URBANISM

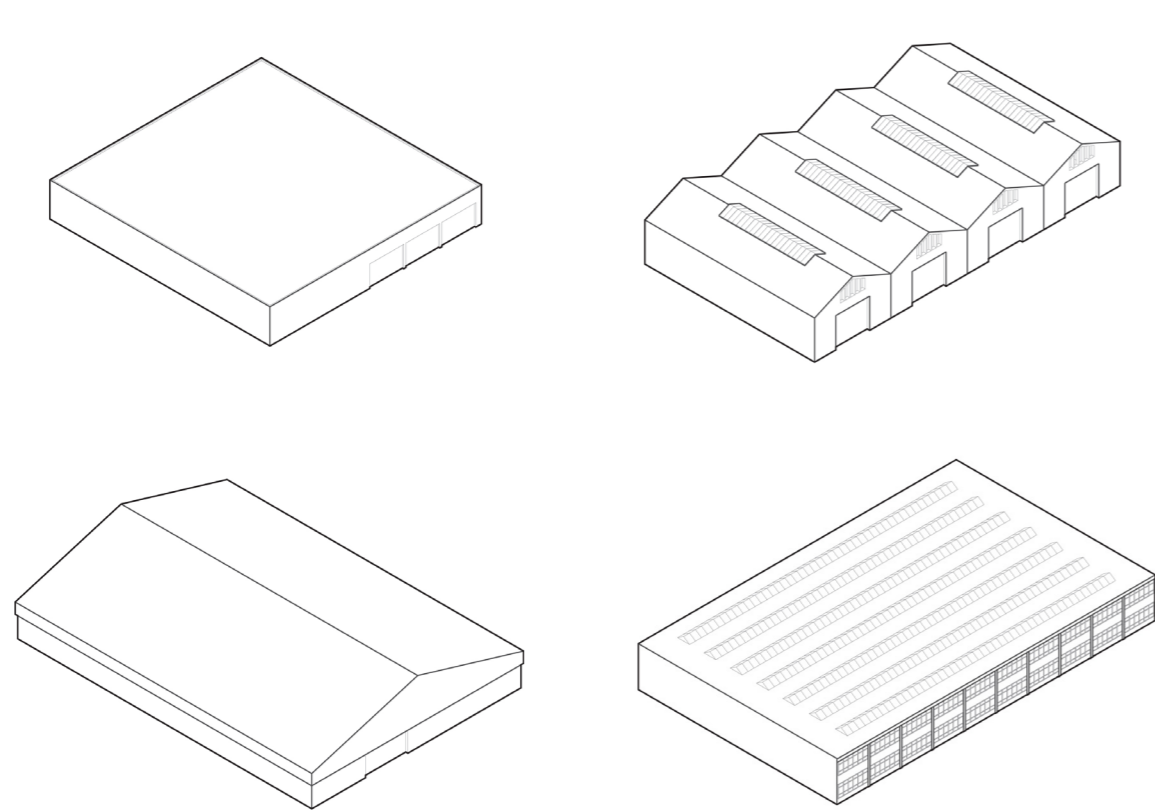

Camouflage



Genericness

Is Binckhorst merely an area of “passing by” with very few points of interest?

PROBLEM

ON URBANISM

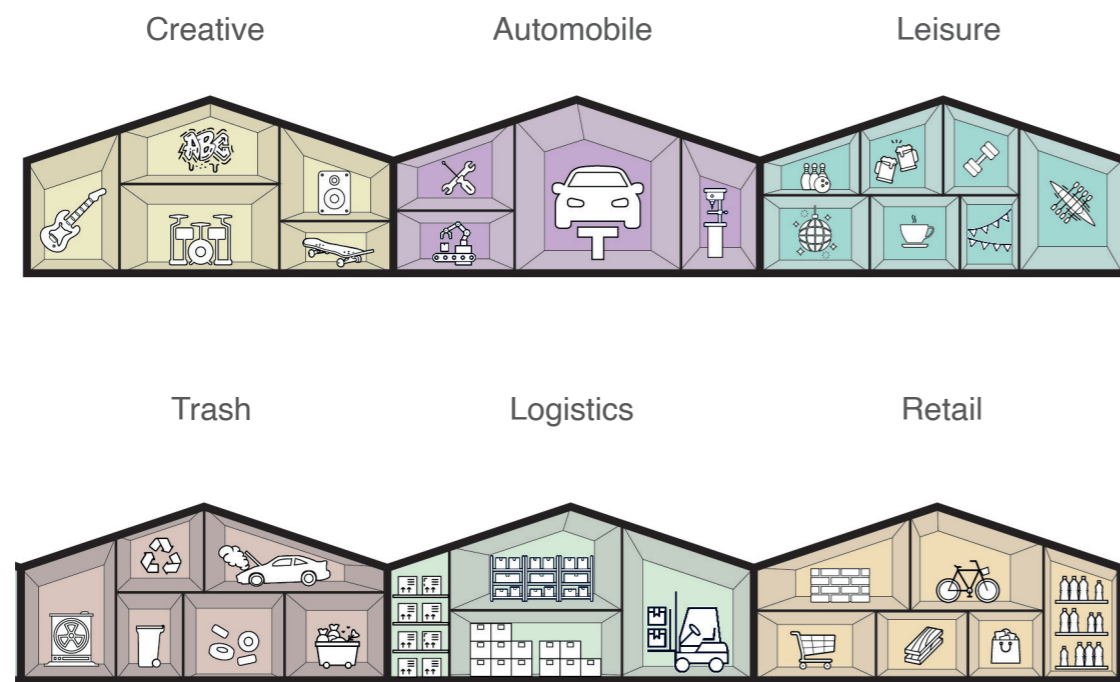

Horizontal Lobotomy

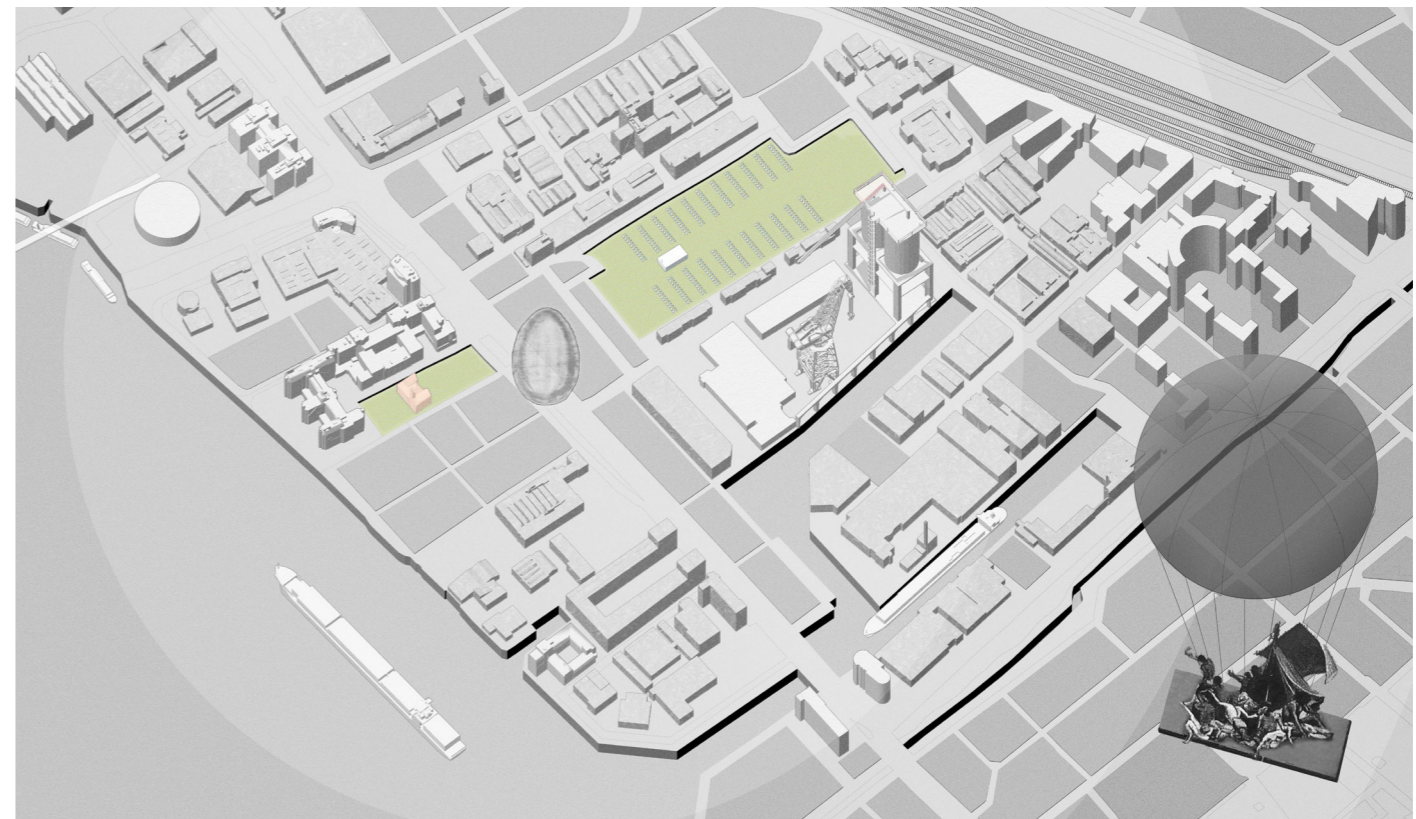

Disarticulation

Is it possible to augment and restructure the sensorial anchors to reverse the monotony of Binckhorst?

BUILDING GROUND

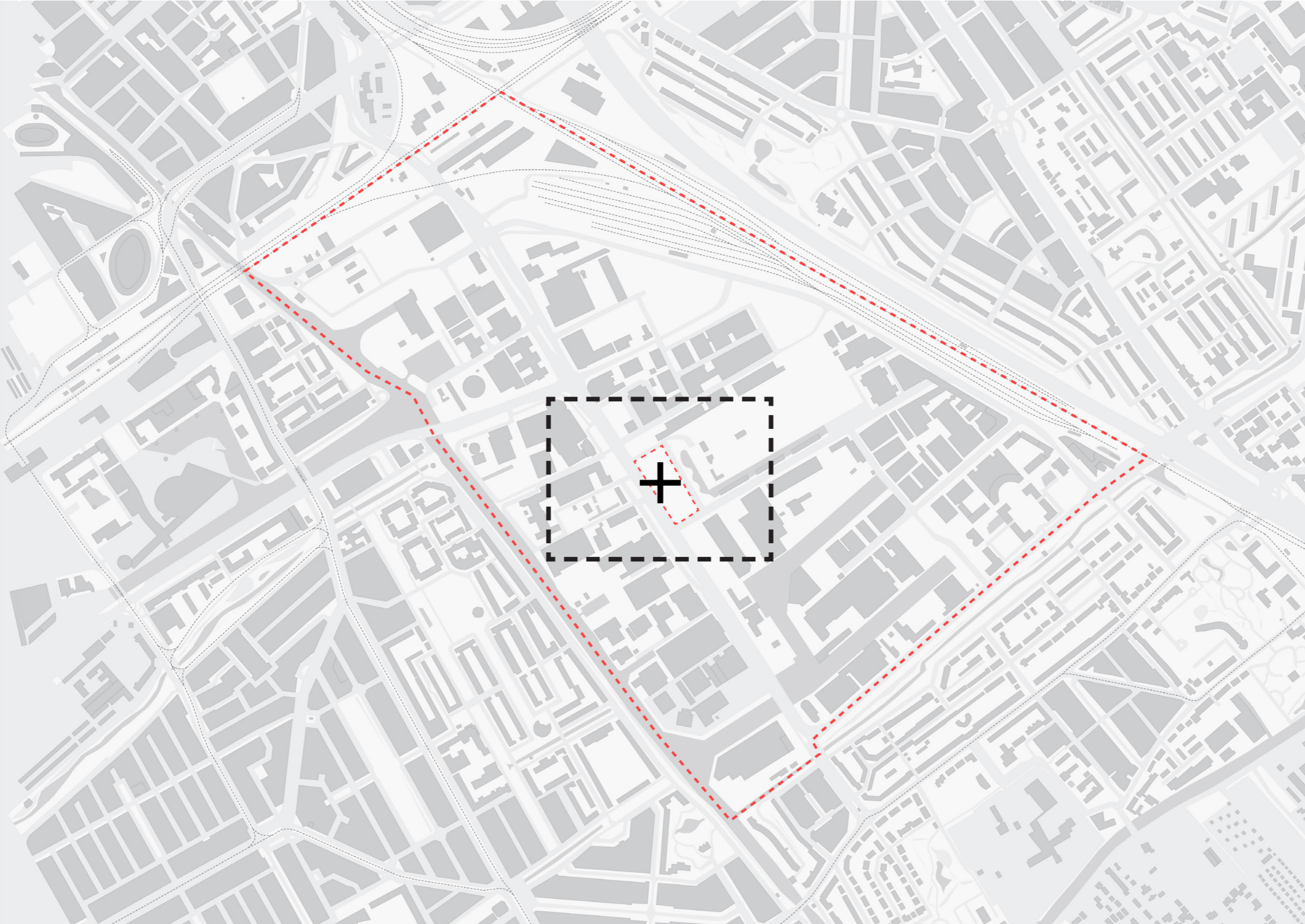

BUILDING GROUND

Binckhorst Castle



Saint Barbara Cemetery



0 15 30 60m

0 10 20 40m



Section A-A

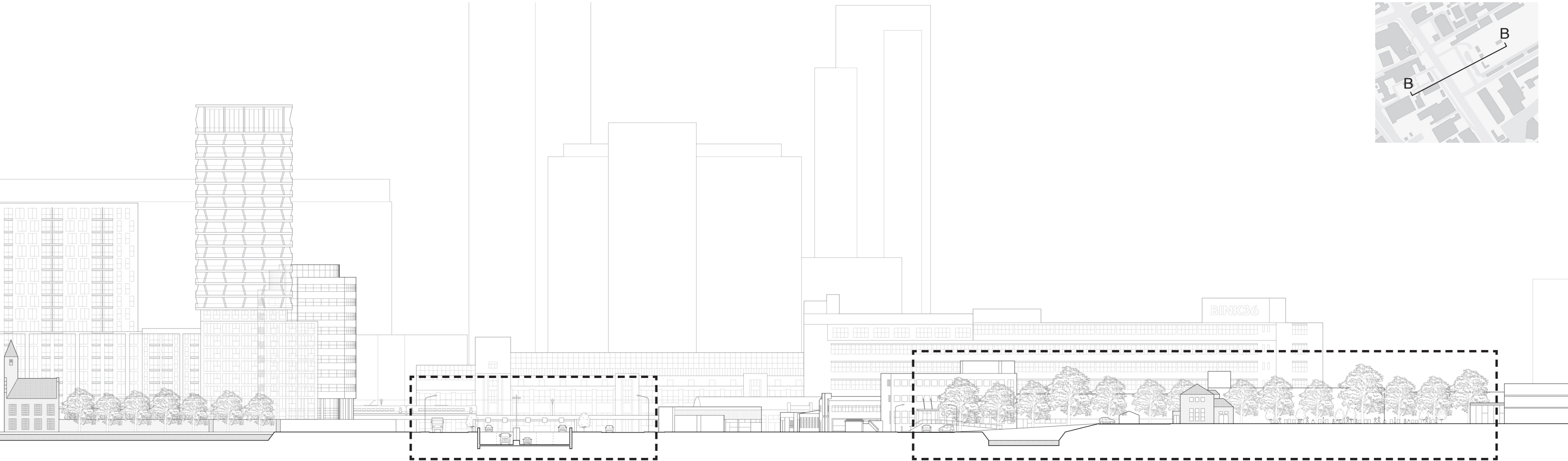
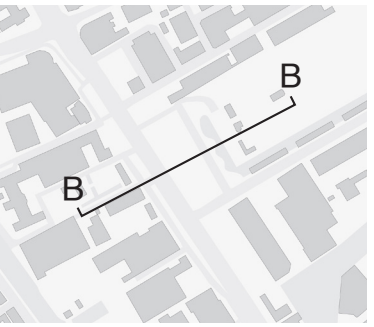

Section B-B

Elevational Photomontage - South to North Facing West



Elevational Photomontage - North to South Facing East



MANIFESTO

REARTICULATING THE DISARTICULATED

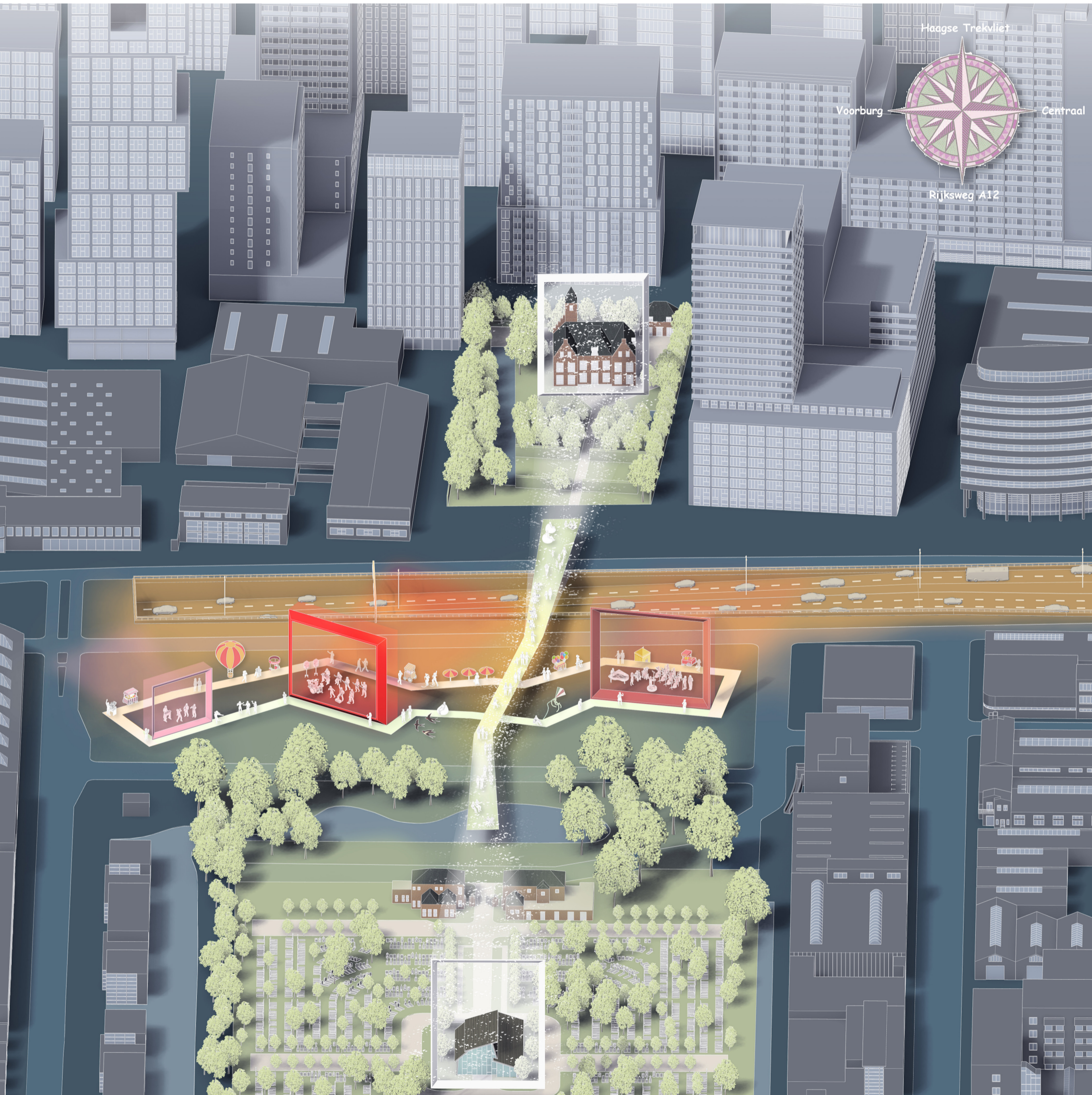

Architecture is about the excavation and release of potentialities hidden in a site or programme.
With respect to Binckhorst, it is about unravelling or enriching its psychologically interpreted colours.
For nothing is in the intellect that was not first in the senses.

PROGRAMME BRIEF



Amare

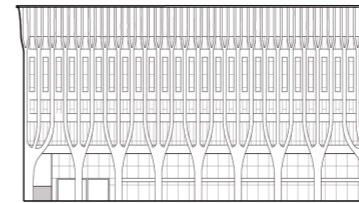

6600

Capacity: Large

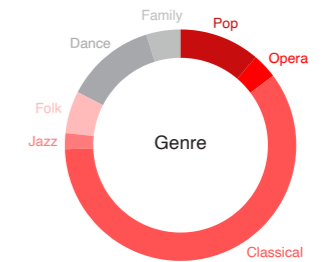

Koninklijk Conservatorium



1000

Capacity: Medium

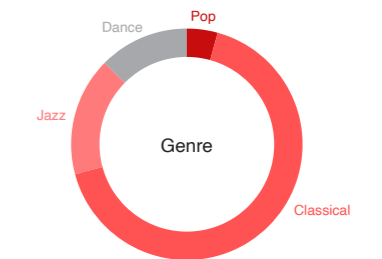

Theater aan het Spui

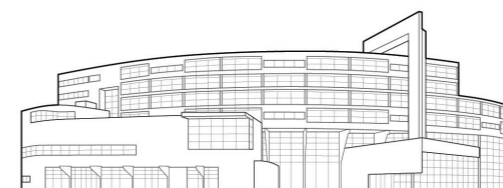

530

Capacity: Small

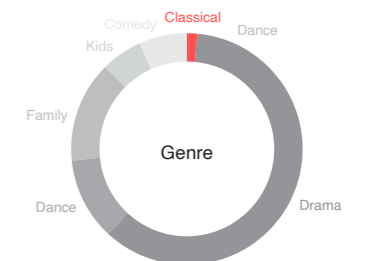

PROGRAMME BRIEF

Classification	Count	Nett (m ²)	Tarra (m ²)	Gross (m ²)	Percentage
Public					
Office	1	60	20	80	1%
Cafe / Lounge	1	130	-	130	1.5%
Food Court	1	200	-	200	2%
Vendor Kitchen	2	50	20	70	1%
Shop	3	60	30	90	1%
Exhibition Gallery	1	20	5	25	0.5%
Young Artists					
Practice Room	13	195	65	260	3%
Composition Room	8	70	10	80	1%
Recording Studio	4	90	60	150	2%
Classroom	3	180	40	220	3%
Library	1	100	20	120	1%
Concertgoers					
Cloak Room	1	35	15	50	0.5%
Lounge	2	100	25	125	1.5%
Jazz Club	1	110	30	140	2%
Rock and Pop Hall	1	300	70	370	5%
Classical Auditorium	1	460	140	600	7%
Performing Artists					
Bar	3	60	20	80	1%
Rehearsal Room	10	160	60	220	2.5%
Changing Room	6	370	100	470	6%
General					
Restroom	10	220	30	250	3%
Bike Rack	160	210	-	210	2.5%
Parking Lot	80	960	-	960	12%
Mechanical	-	-	250	250	3%
Indoor Circulation	-	-	3000	3000	37%
Total	-	4140	4010	8150	100%

120

School Capacity: Small

400

Rock and Pop Hall Capacity: Small

250

Classical Auditorium Capacity: Small

50

Jazz Club Capacity: Extra Small

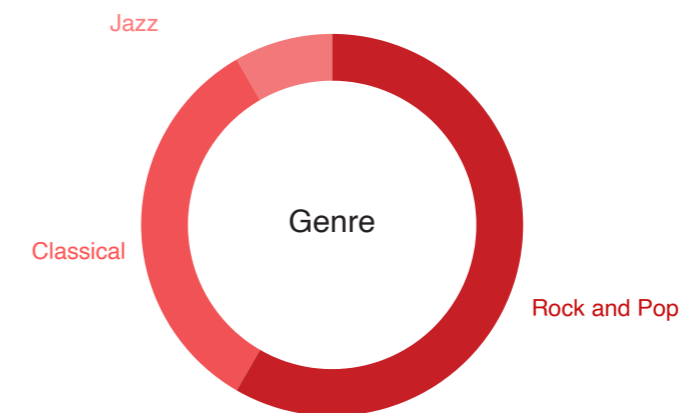

METHOD

NOTATIONAL SYSTEM

Film Storyboard

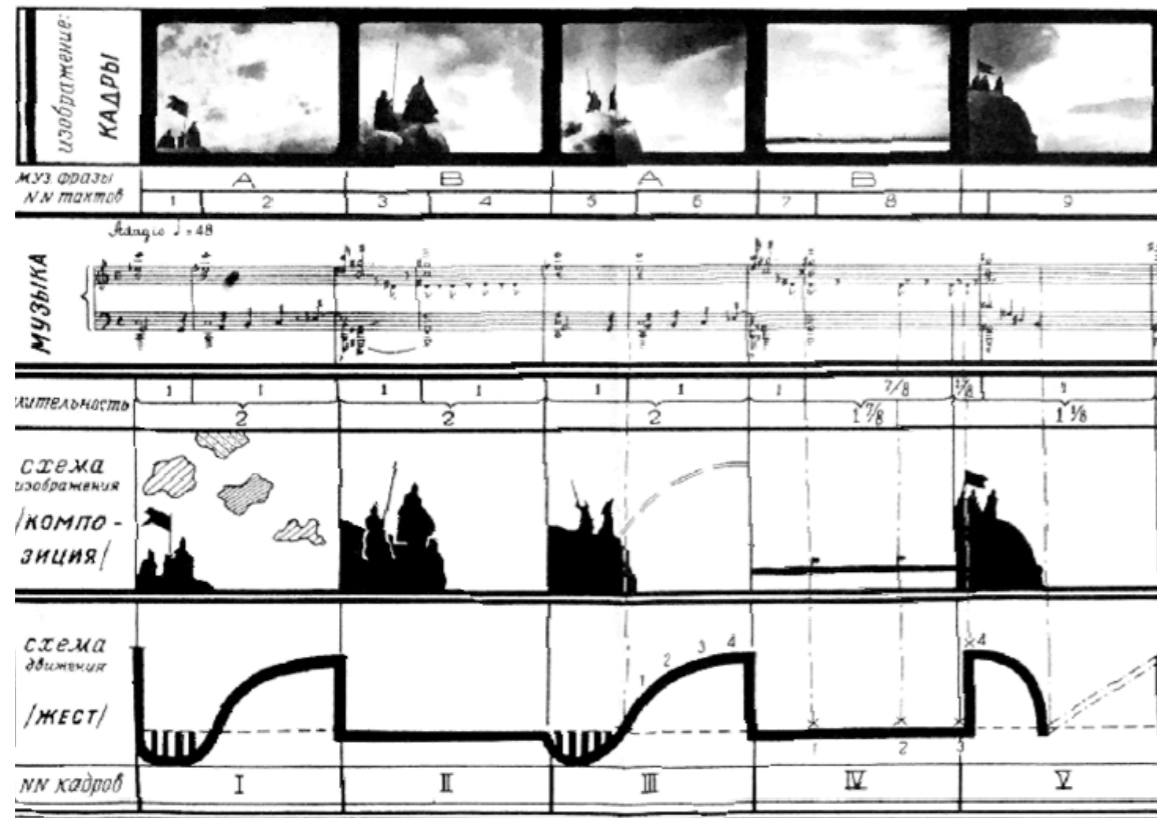

Visual rendition of Audiovisual Correspondences, Sergei Eisenstein (1938)

Architectural Narrative

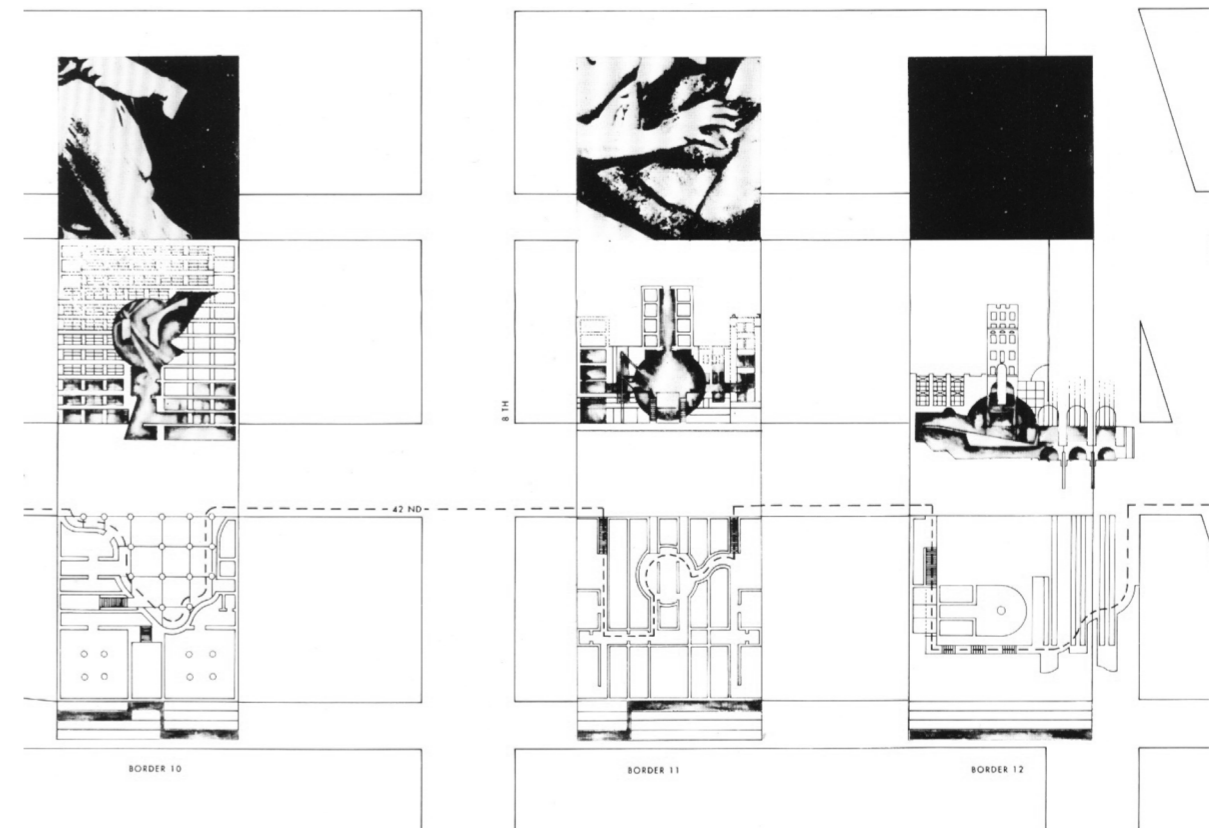

MT 2, Bernard Tschumi (1981)

Since when has the sonic dimension of architectural experience become lost in our discipline?

ACOUSTIC SPACE

REINSTATING SOUNDS AS SPACEMAKERS

Sound Types

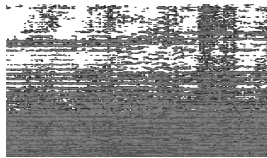

Concert Music



Chamber Music

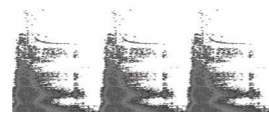

Vehicles

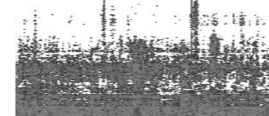

Crowd



Birds

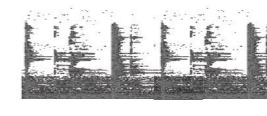

Metal Chimes

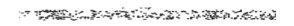

Silence

Atmospheres of Space

Passionate
Vibrant
Exciting

Passionate
Vibrant
Exciting

Loud
Obtrusive
Speedy

Cheerful
Optimistic
Warm

Calm
Peaceful
Reassuring

Neutral
Pure
Reclusive

Mysterious
Uncertain
Power

Programmatic Zones

Classical Auditorium
Rock and Pop Hall
Jazz Club
Practice Room
Rehearsal Room

Street Busking Area
Playground
Marketplace
Coda

Food Court
Classroom
Box Office
Bar
Retail Store
Cloakroom

Lounge
Composition Room
Study Room

Changing Room
Restroom
Recording Studio

Prelude

AUDIO-VISUAL SPATIAL SEQUENCING

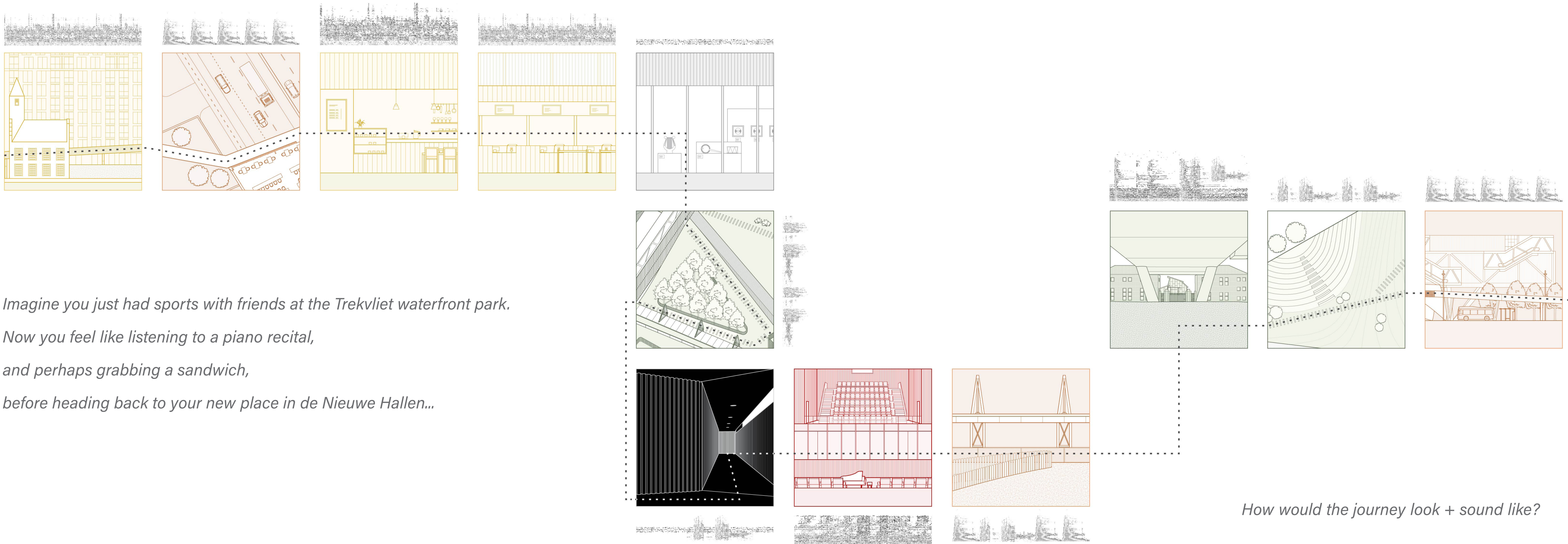

*Imagine you just had sports with friends at the Trekvliet waterfront park.
Now you feel like listening to a piano recital,
and perhaps grabbing a sandwich,
before heading back to your new place in de Nieuwe Hallen...*

How would the journey look + sound like?

FROM LINES OF MOVEMENT TO ARCHITECTURAL FORM



Do the programmatic splices have to be strictly linear?

Can they be intersected or stacked?

LANDSCAPING OPPORTUNITY

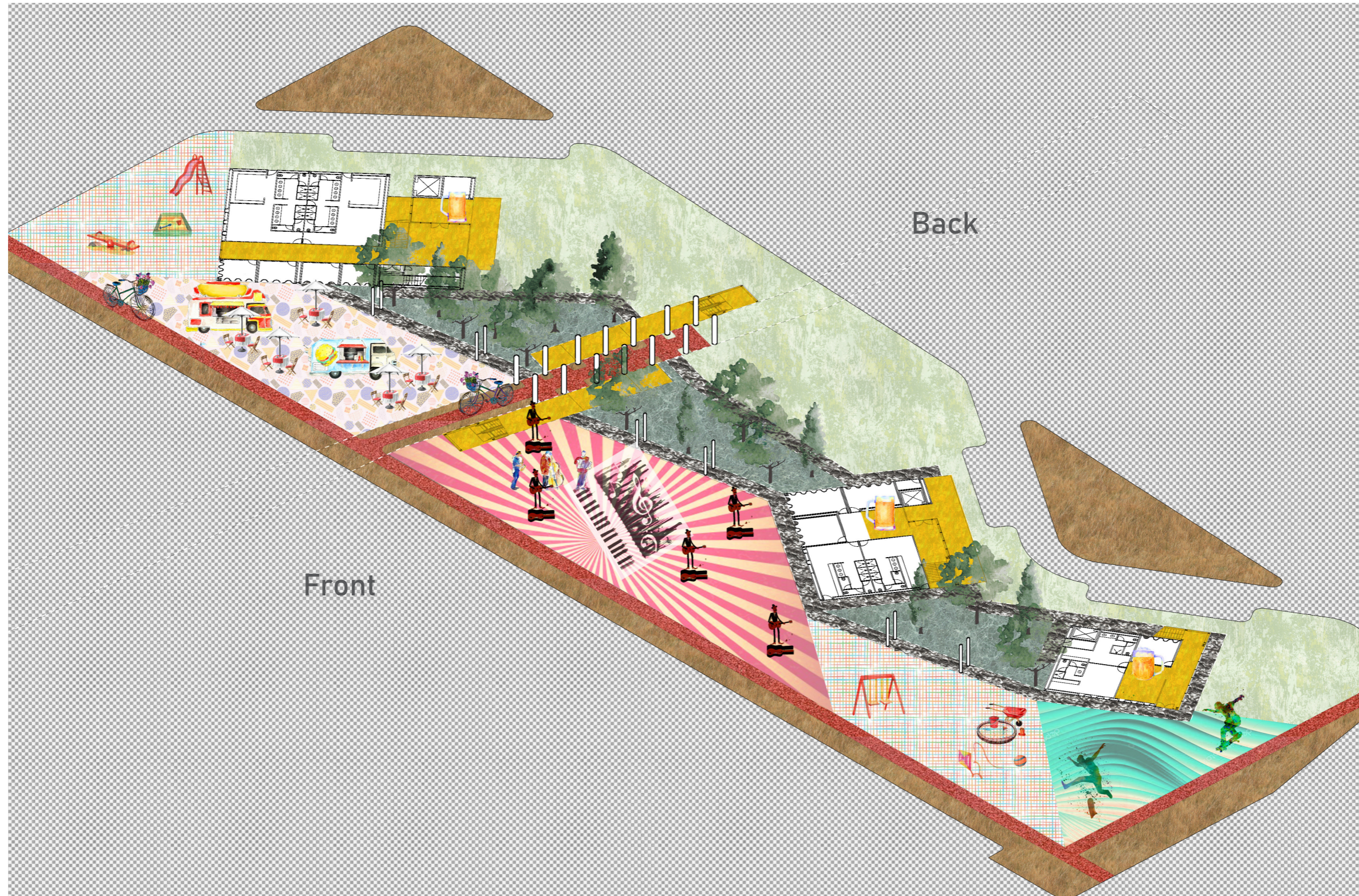

DEVELOPMENT - ARTIFICIAL LANDSCAPE

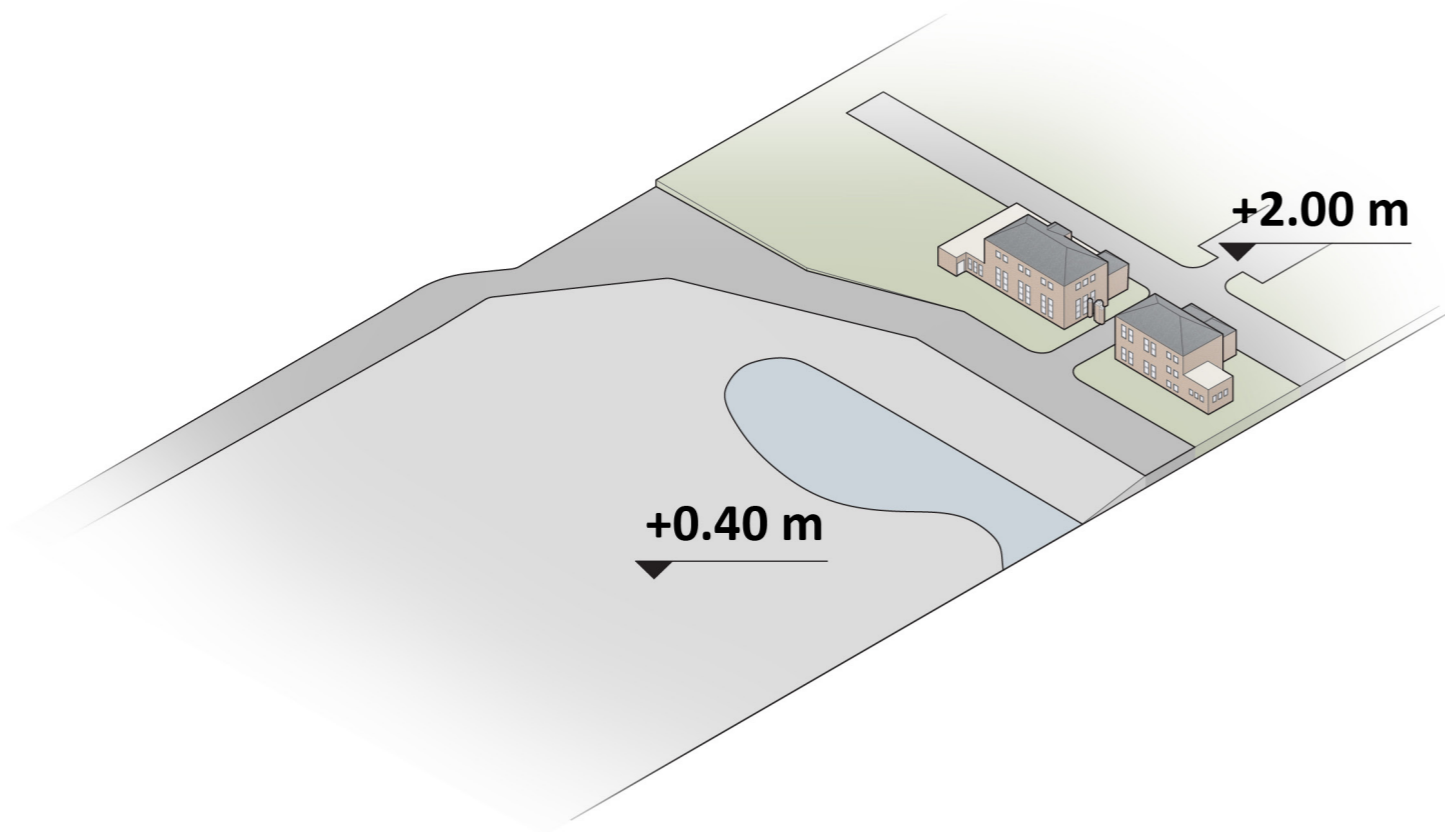

Level Difference

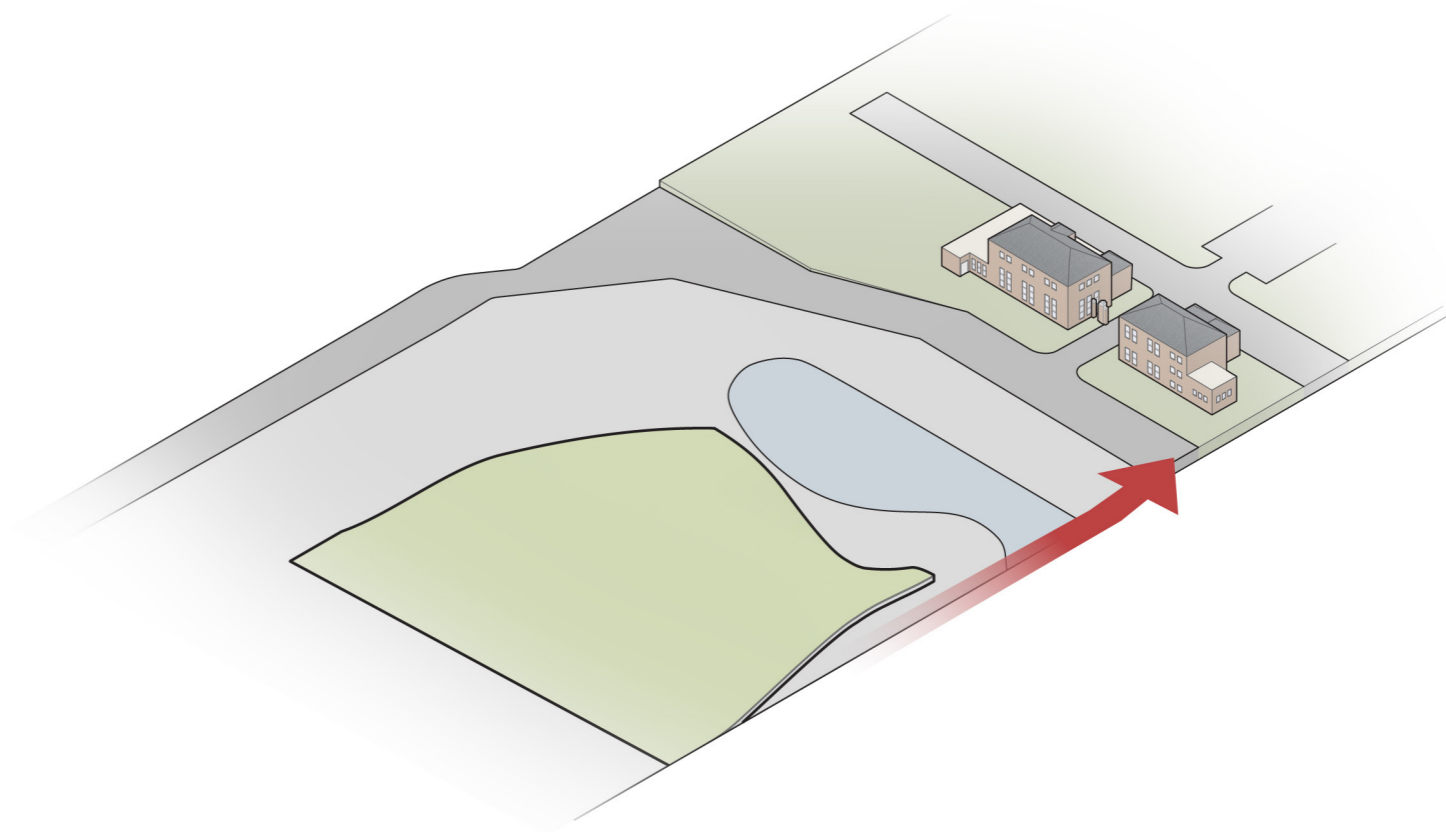

Dialogue

DEVELOPMENT - ARTIFICIAL LANDSCAPE

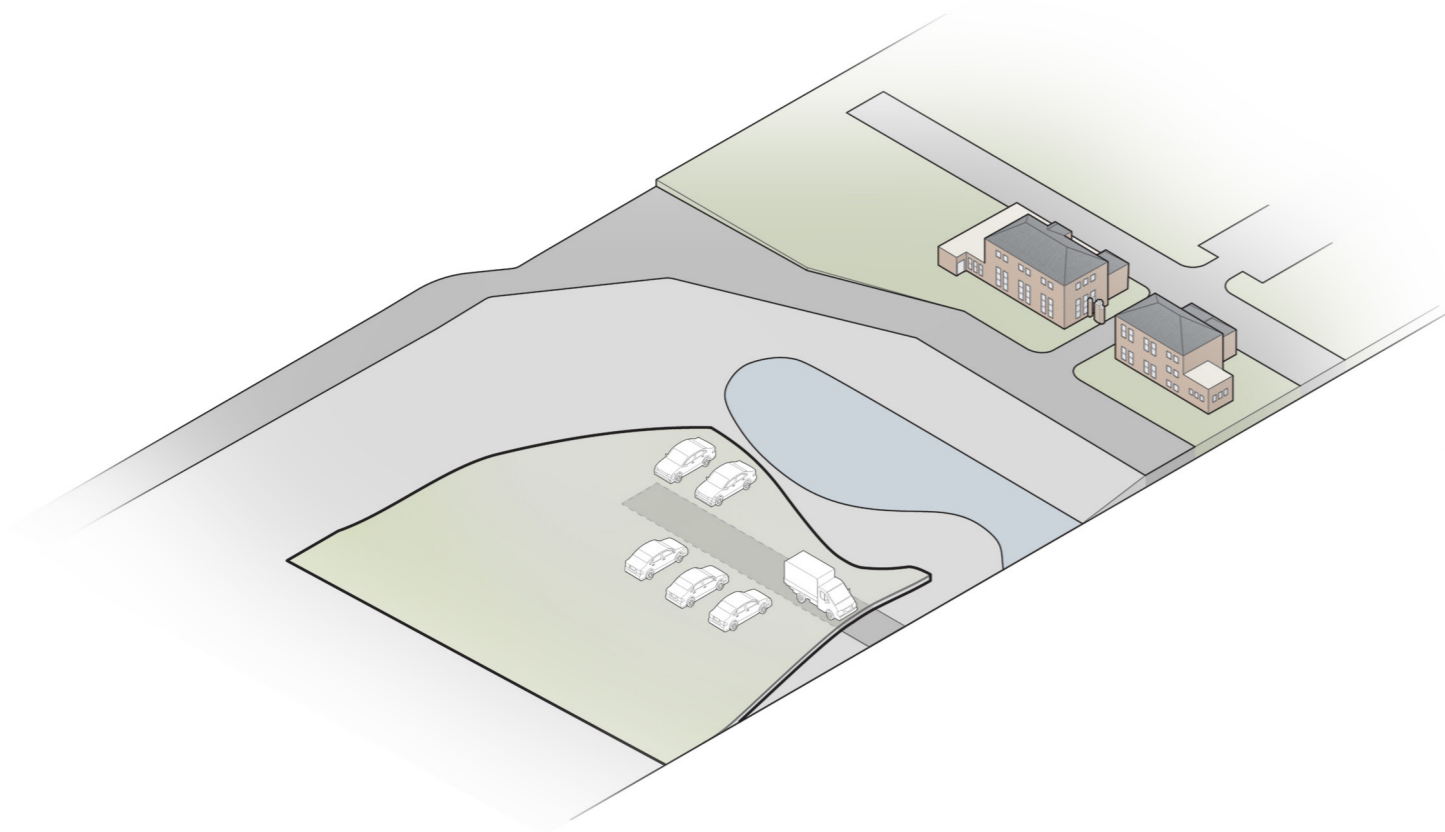

Back of House Concealment

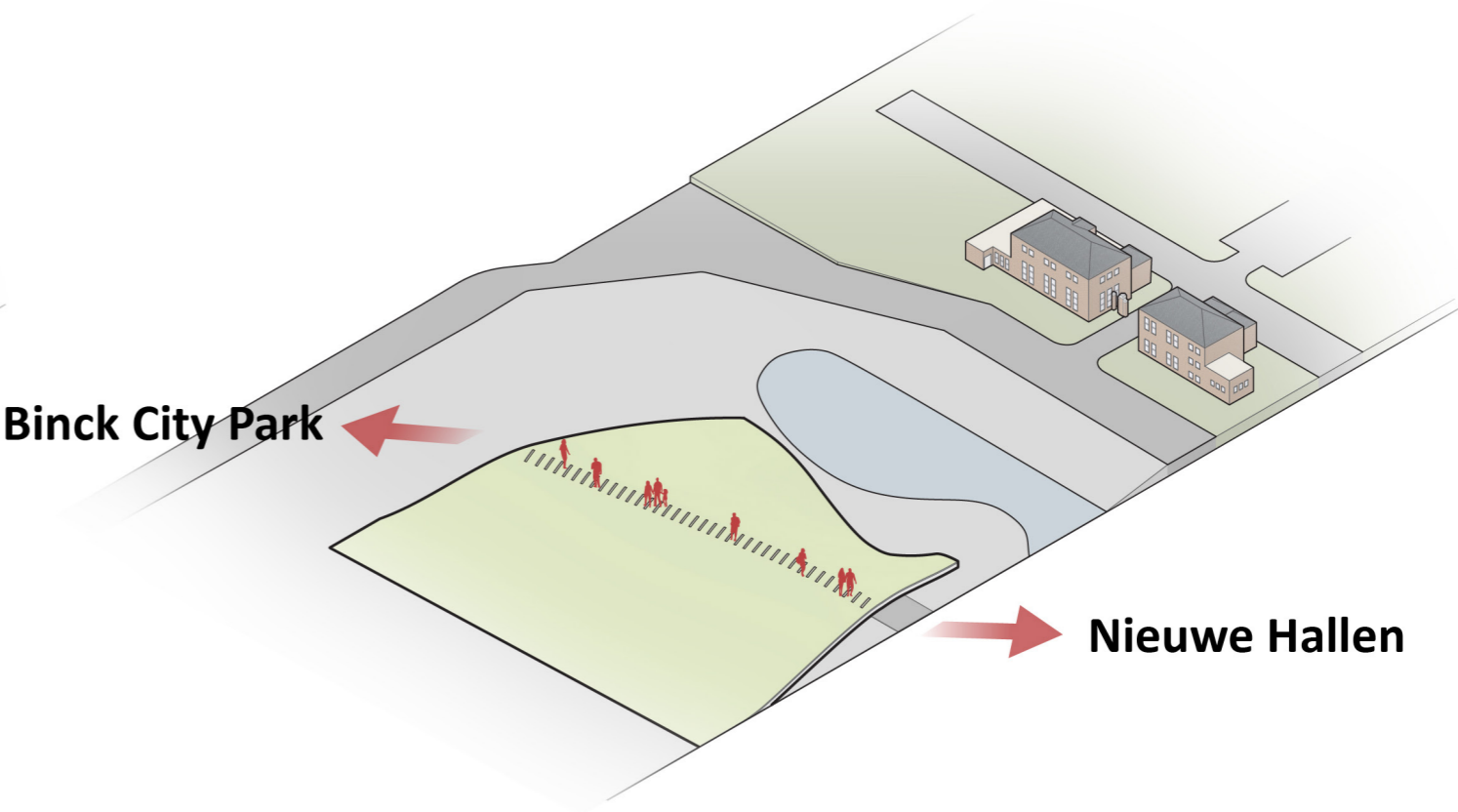

Possible Urban Linkage

DEVELOPMENT - ARTIFICIAL LANDSCAPE

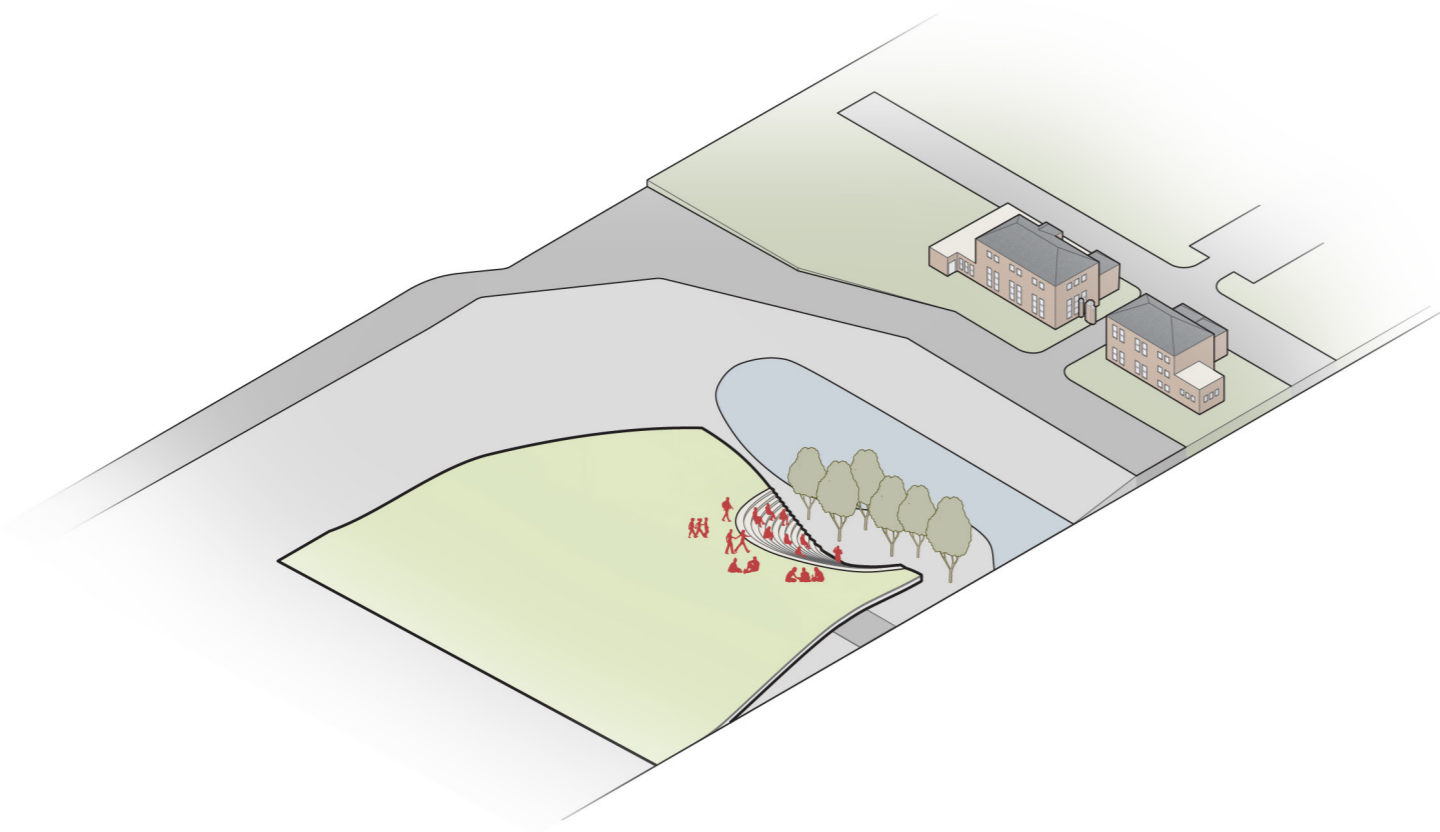

Extra Performing Arts Venue

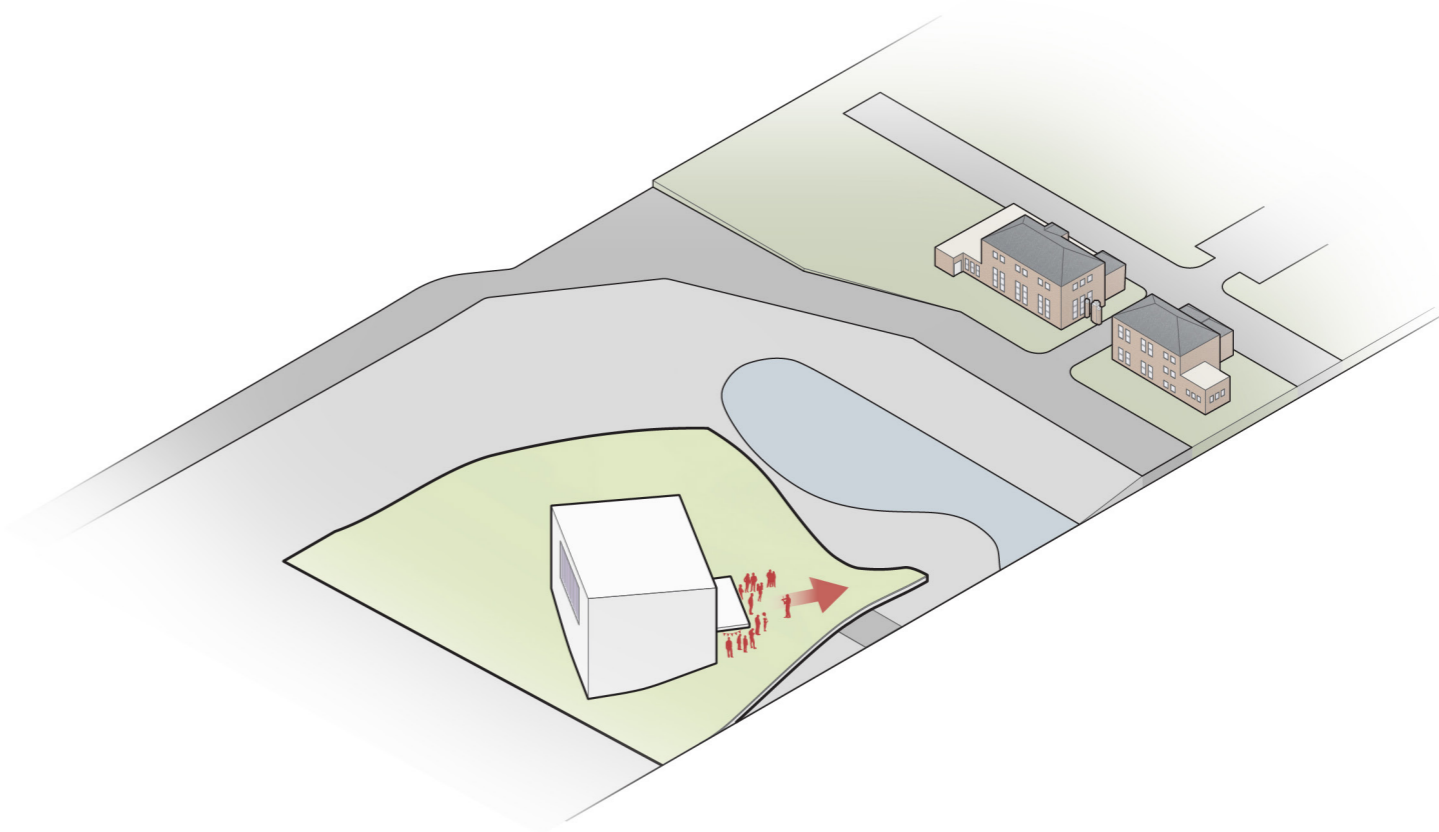

Outward Diffusion

FINAL DESIGN

BUILDING + LANDSCAPE

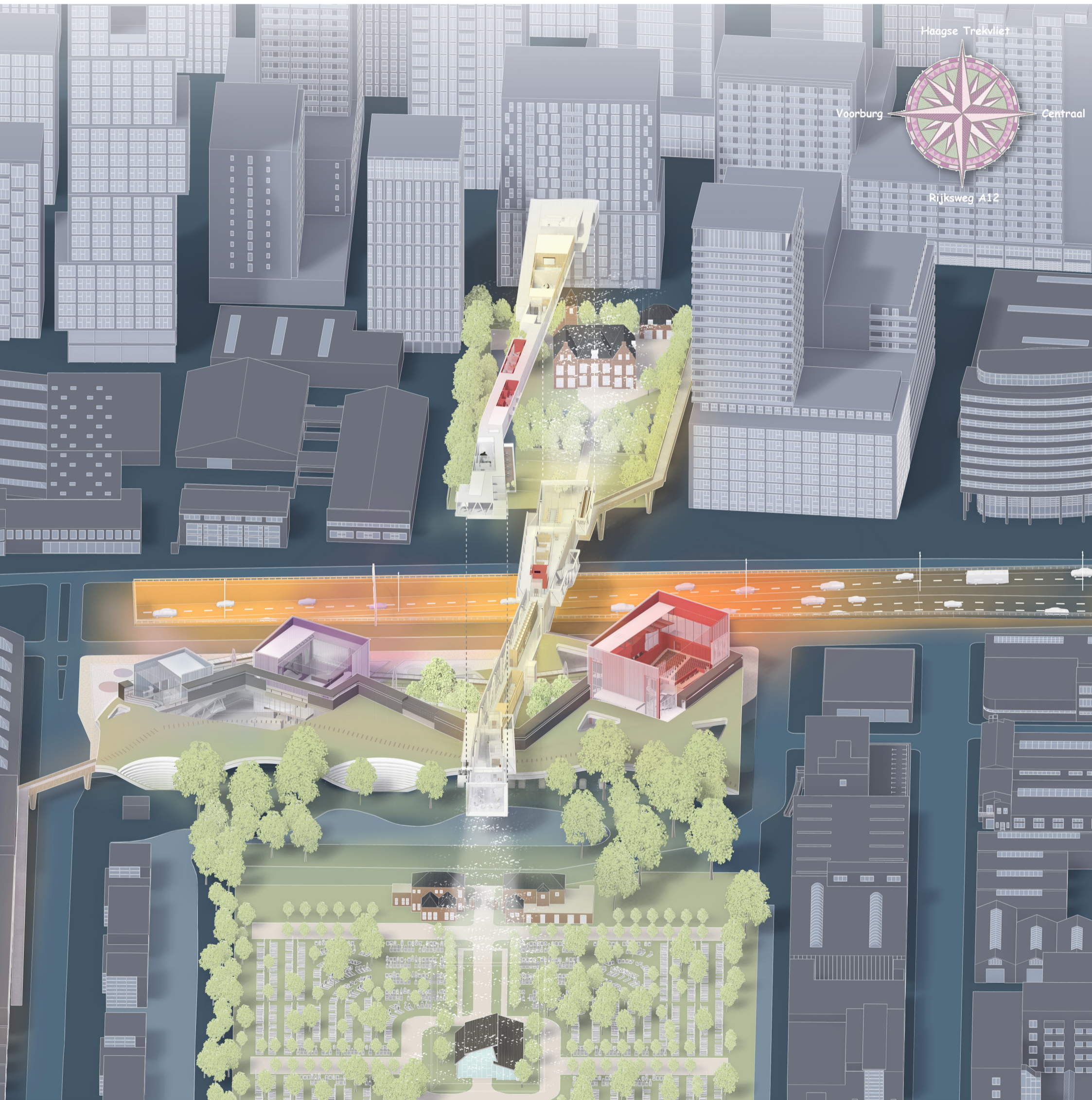

DISSECTION

4 MAIN CHARACTERS

Programme
Circulation
Experience

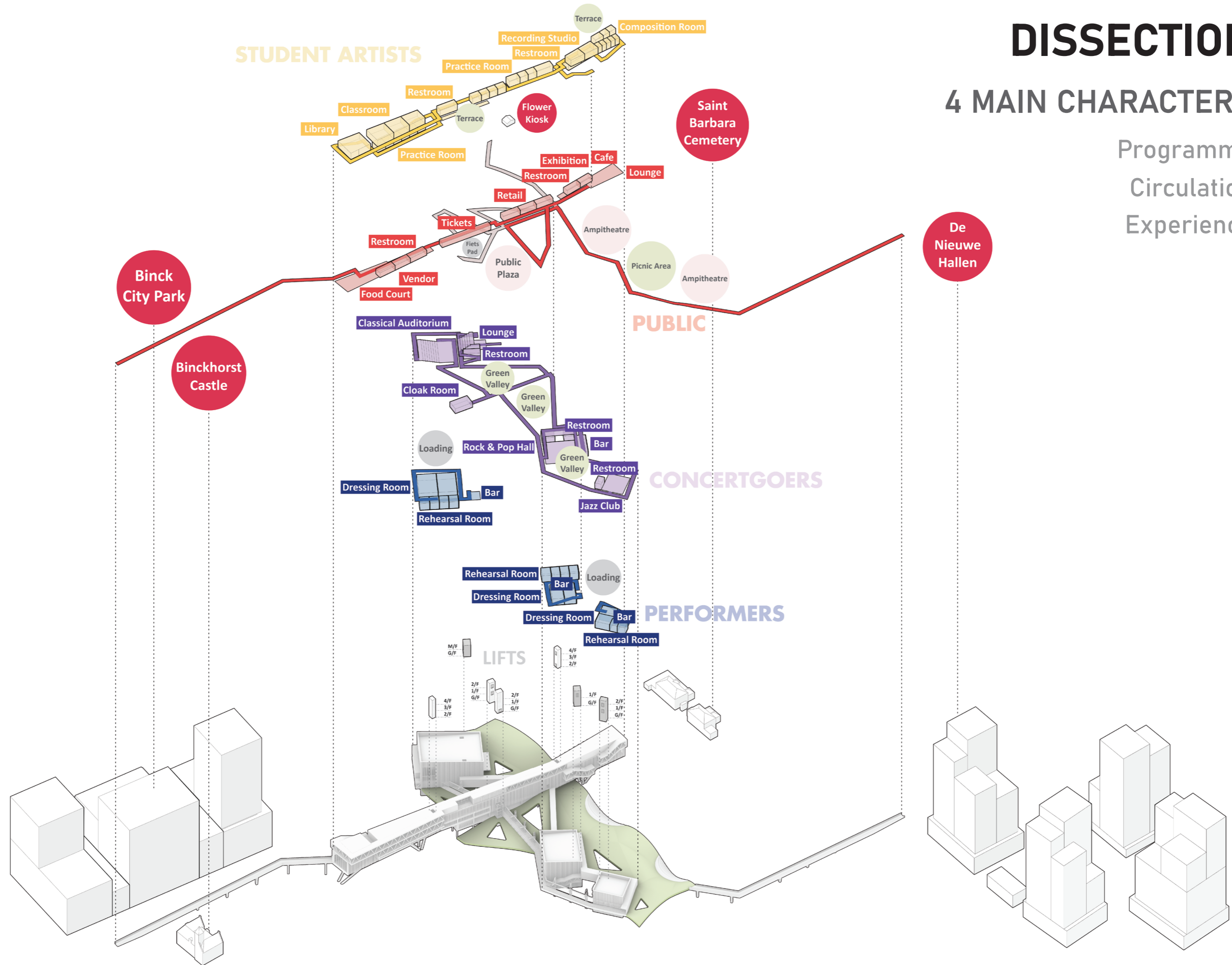

PUBLIC CORRIDOR

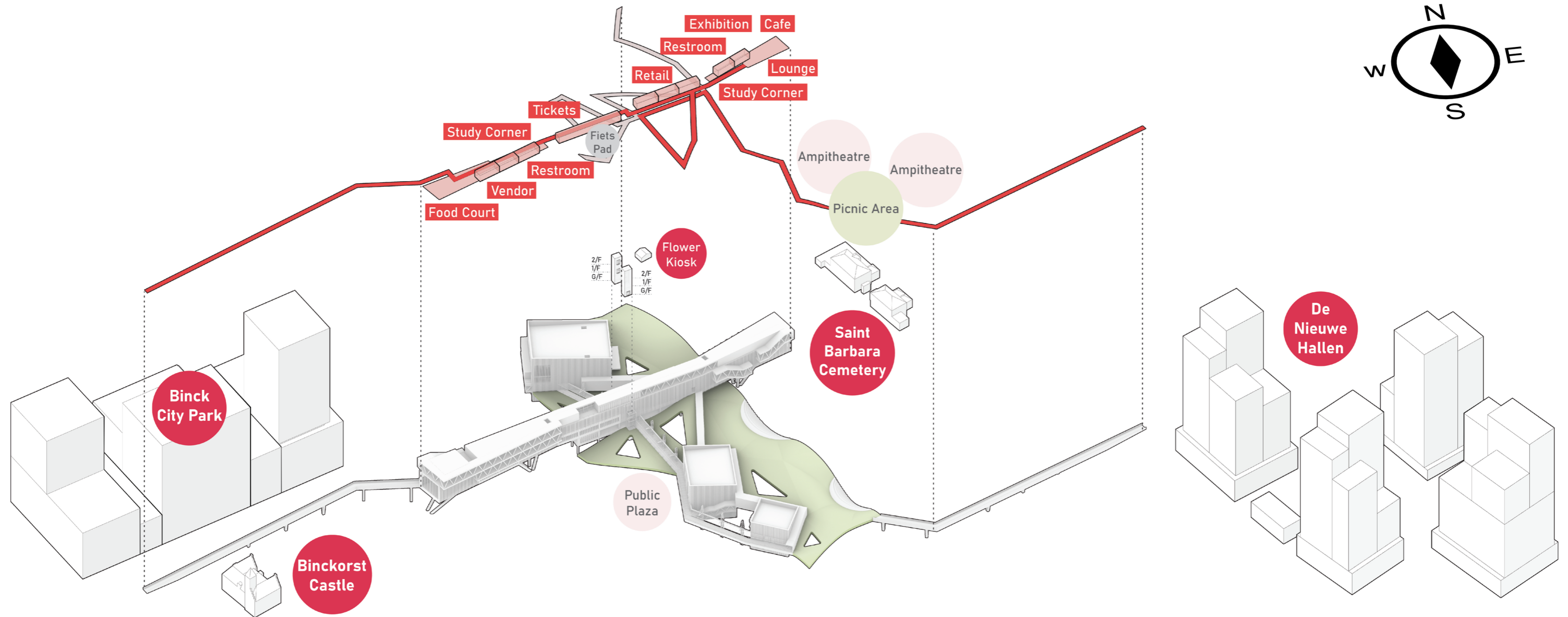

ORIGINAL CONNECTION

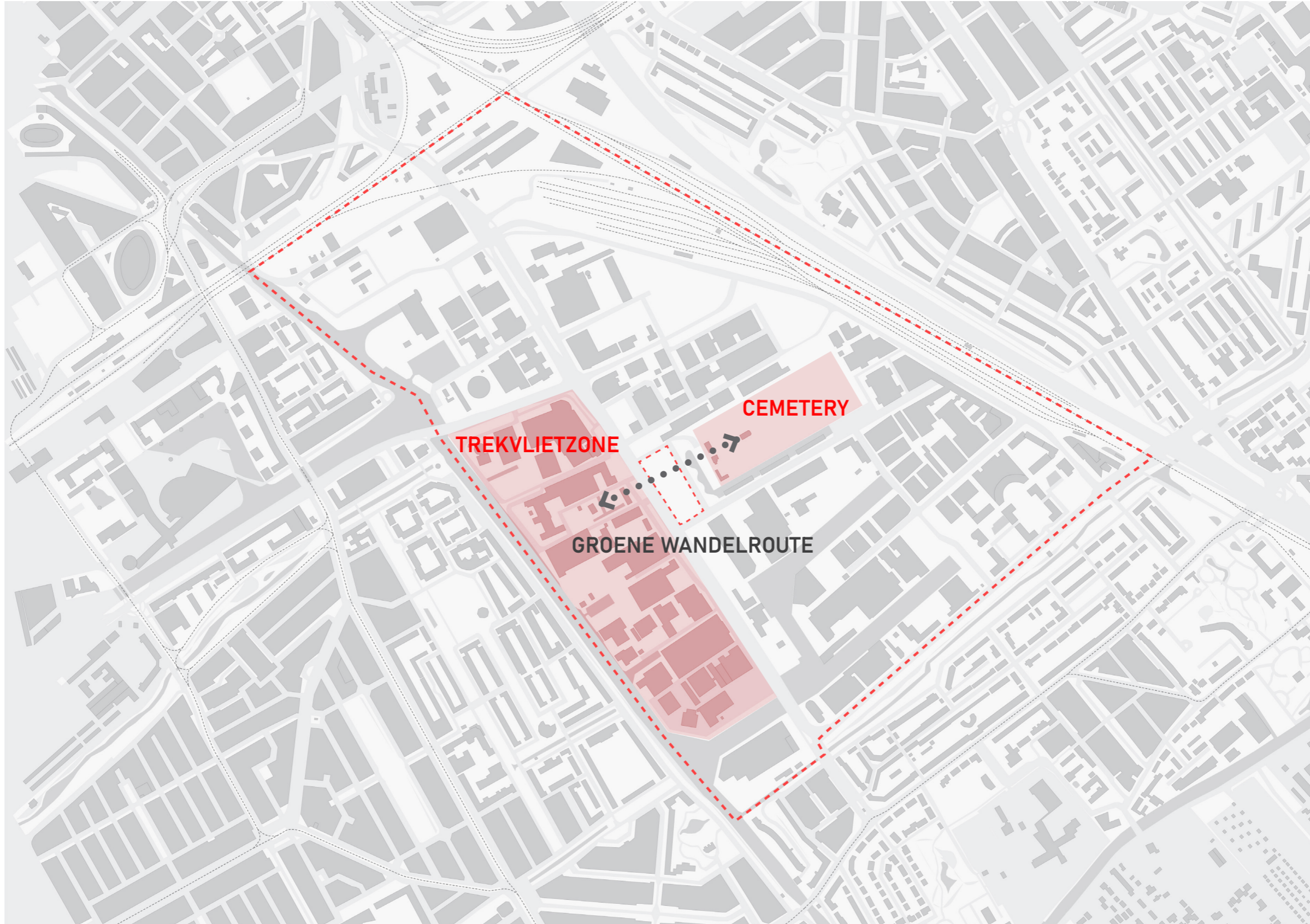

REVISED CONNECTION

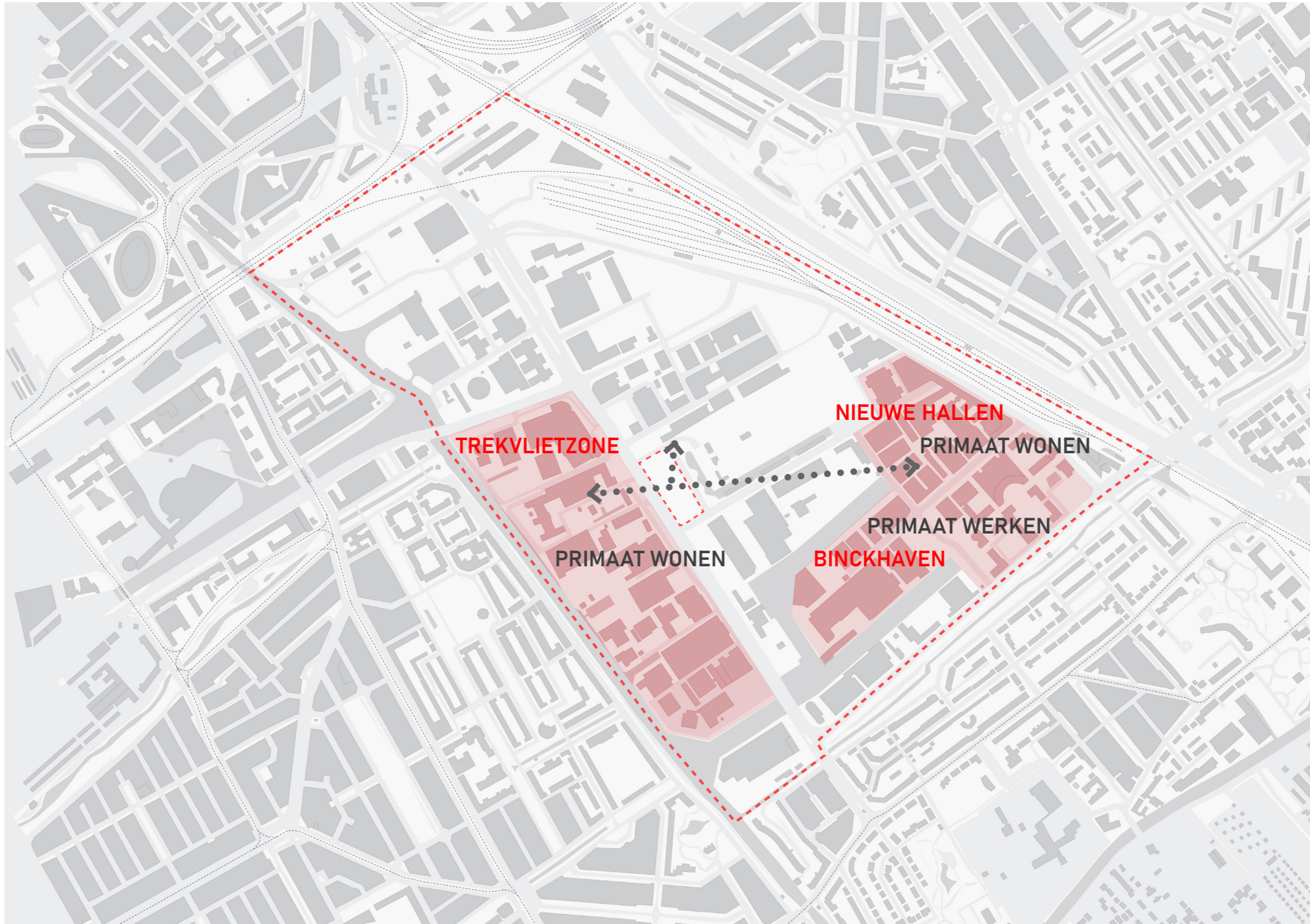

SECTION AA

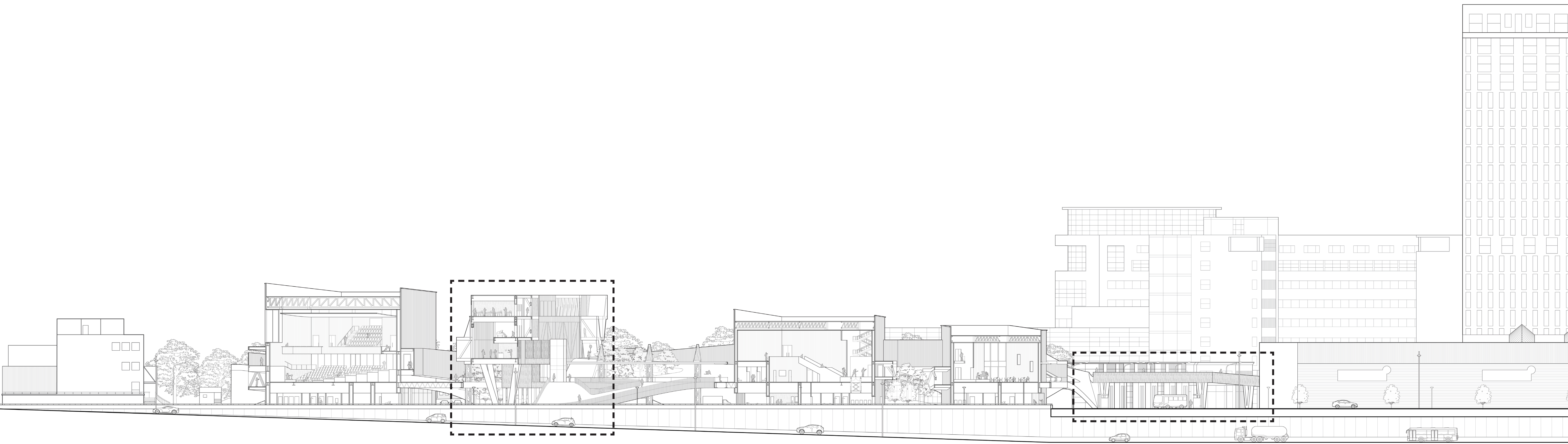
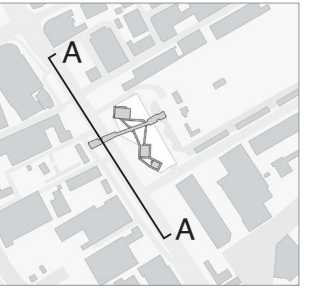

SECTION BB

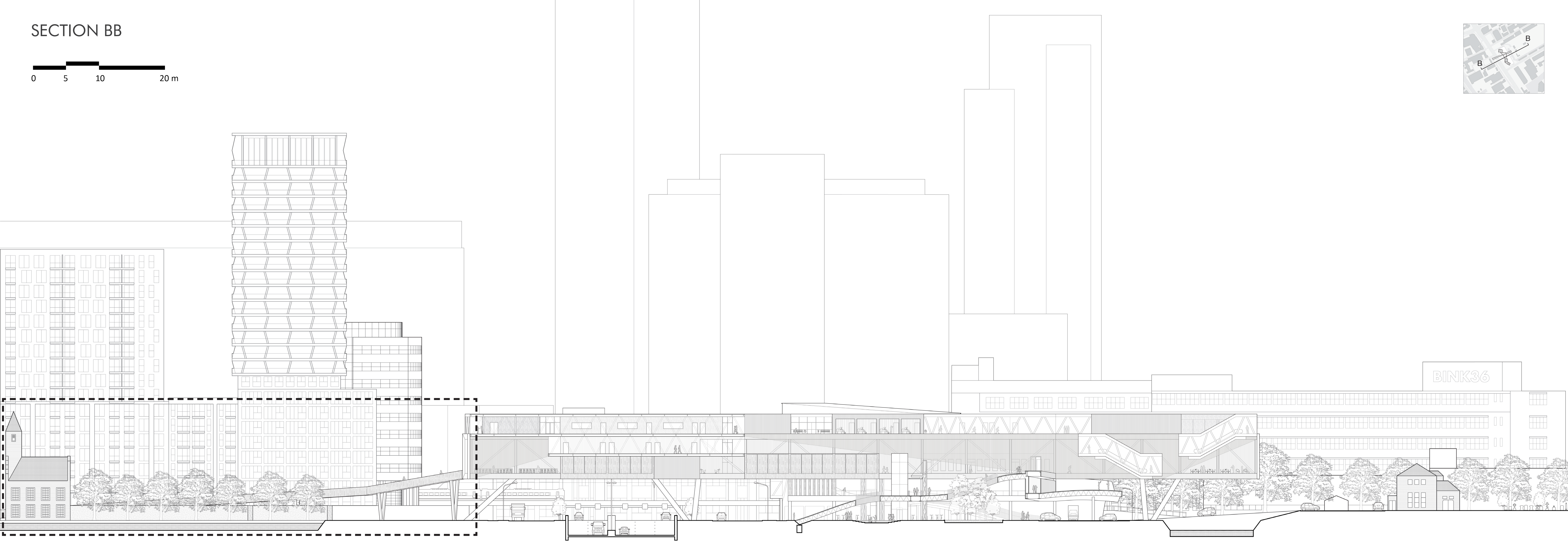
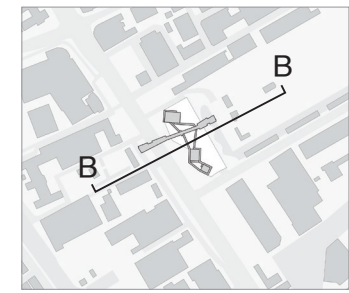

PUBLIC CORRIDOR - FOOD TO GO

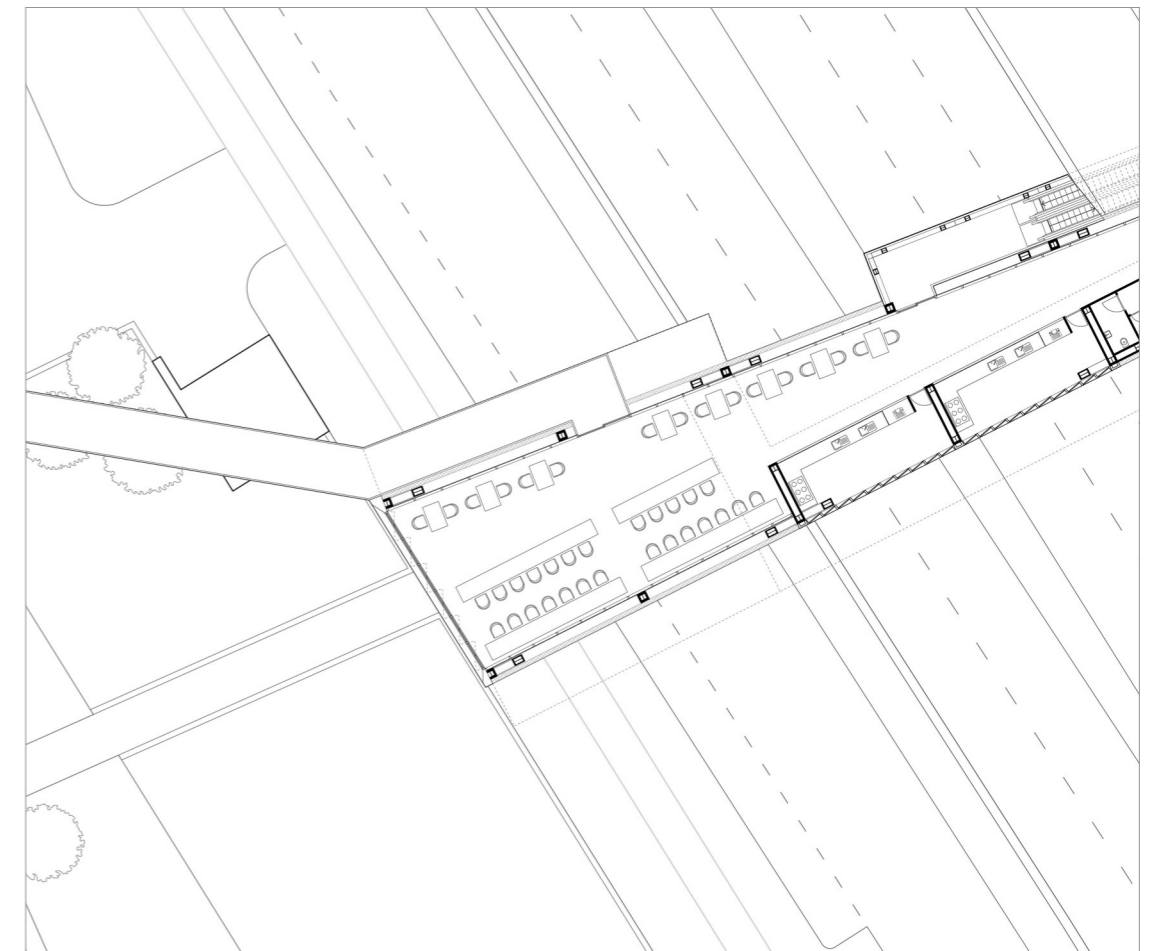
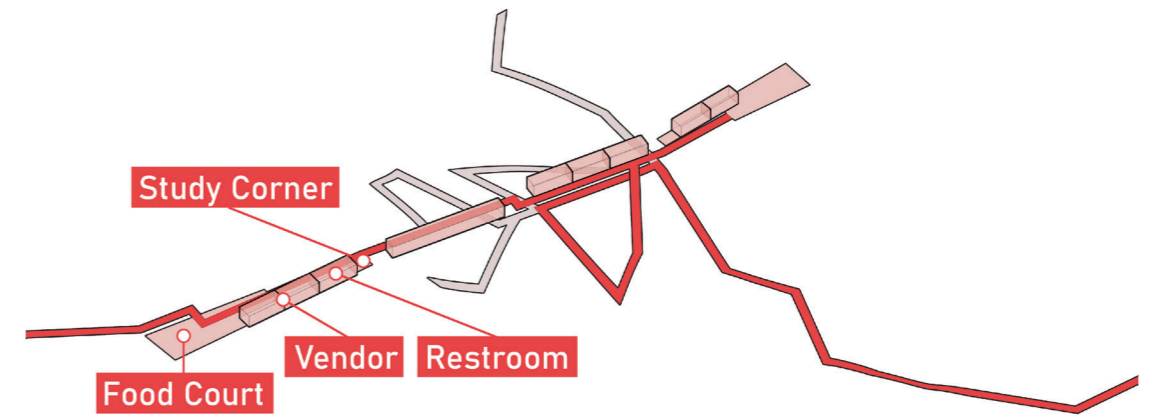
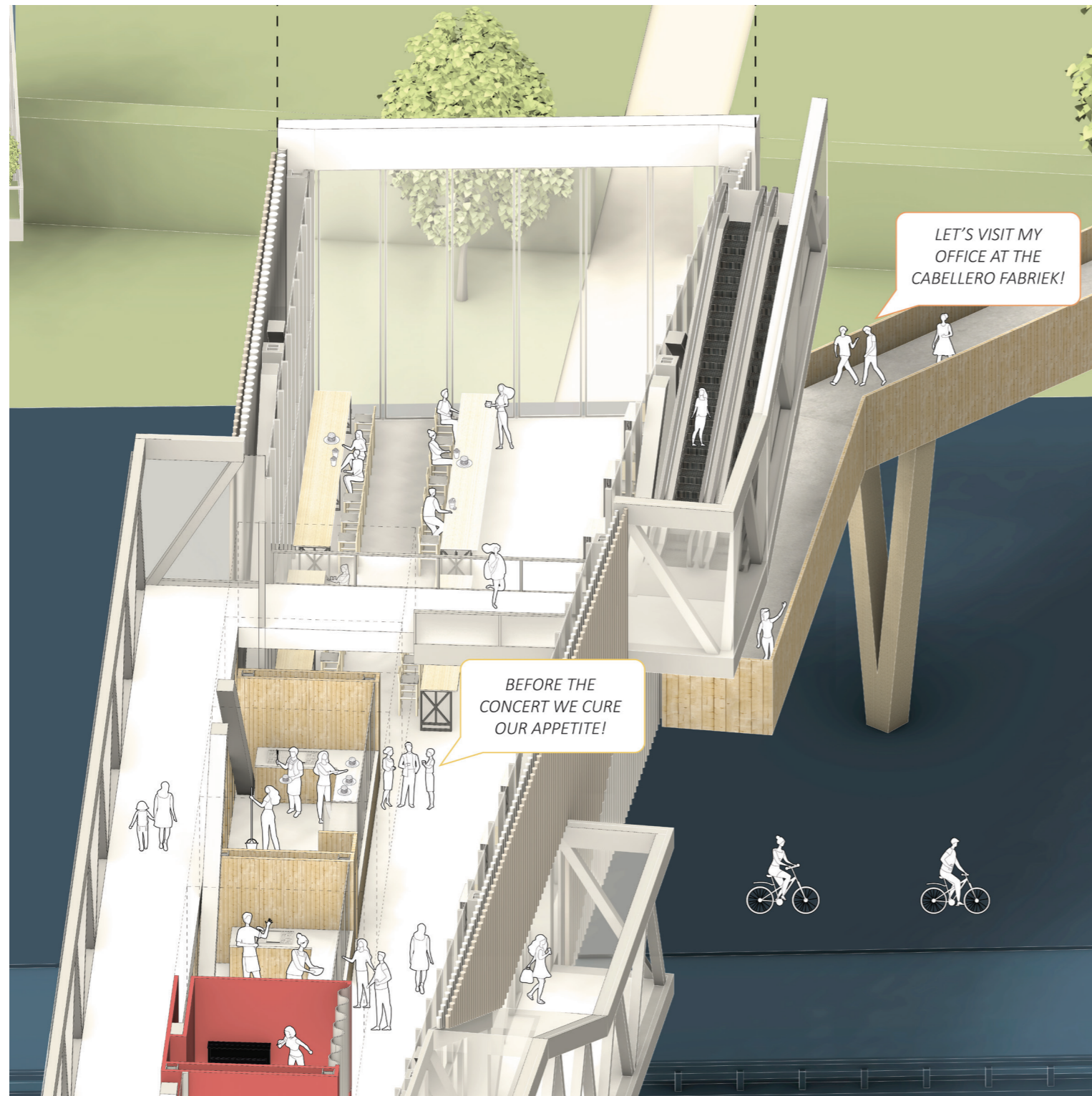







PUBLIC CORRIDOR - SERVICES & SUPPLIES

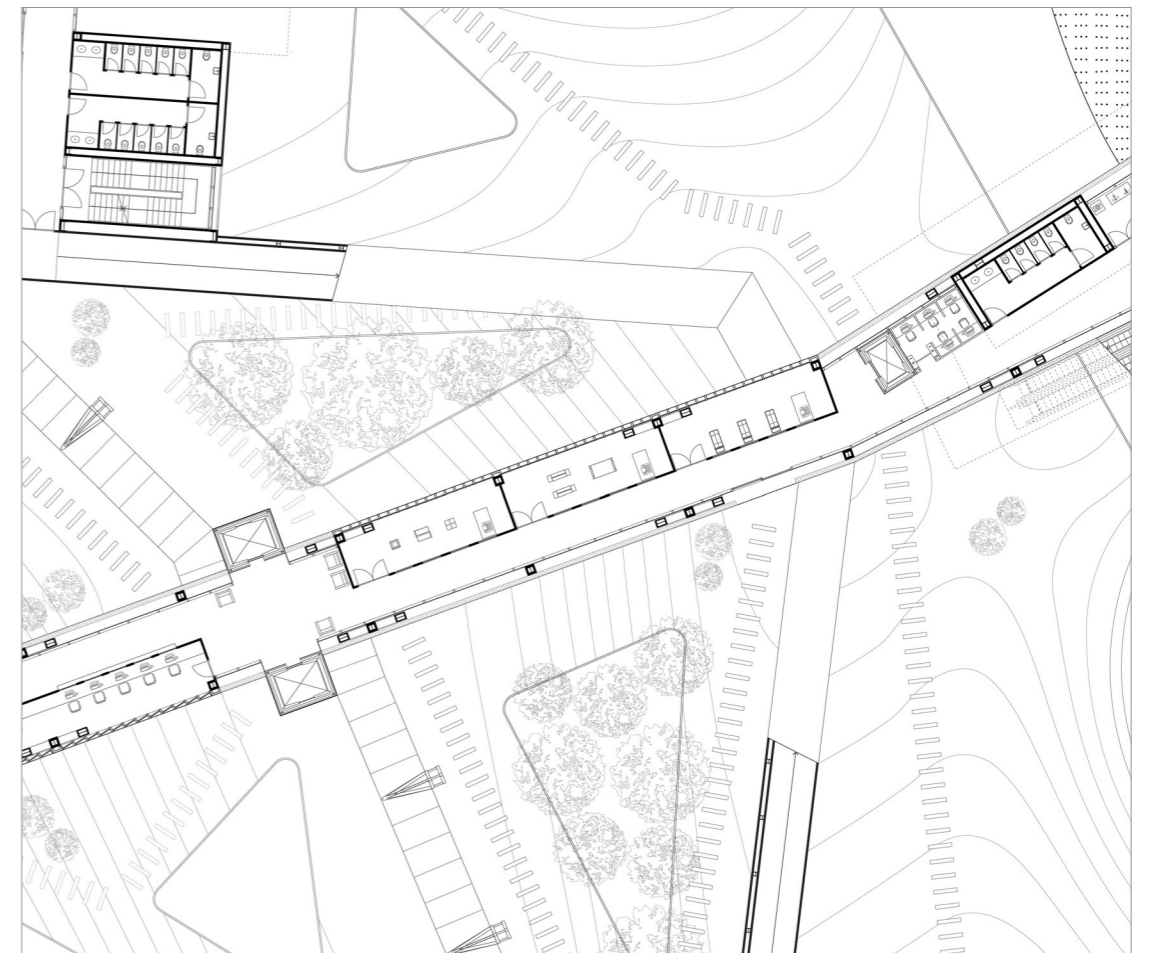
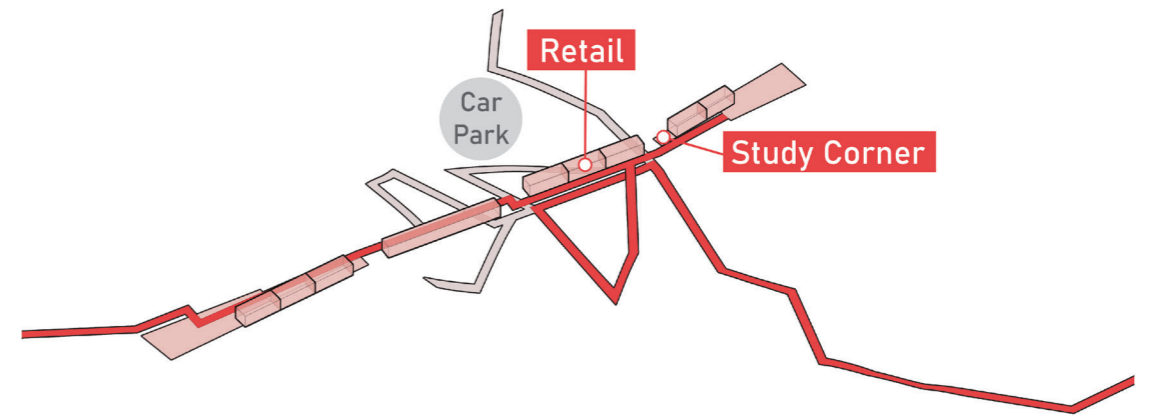
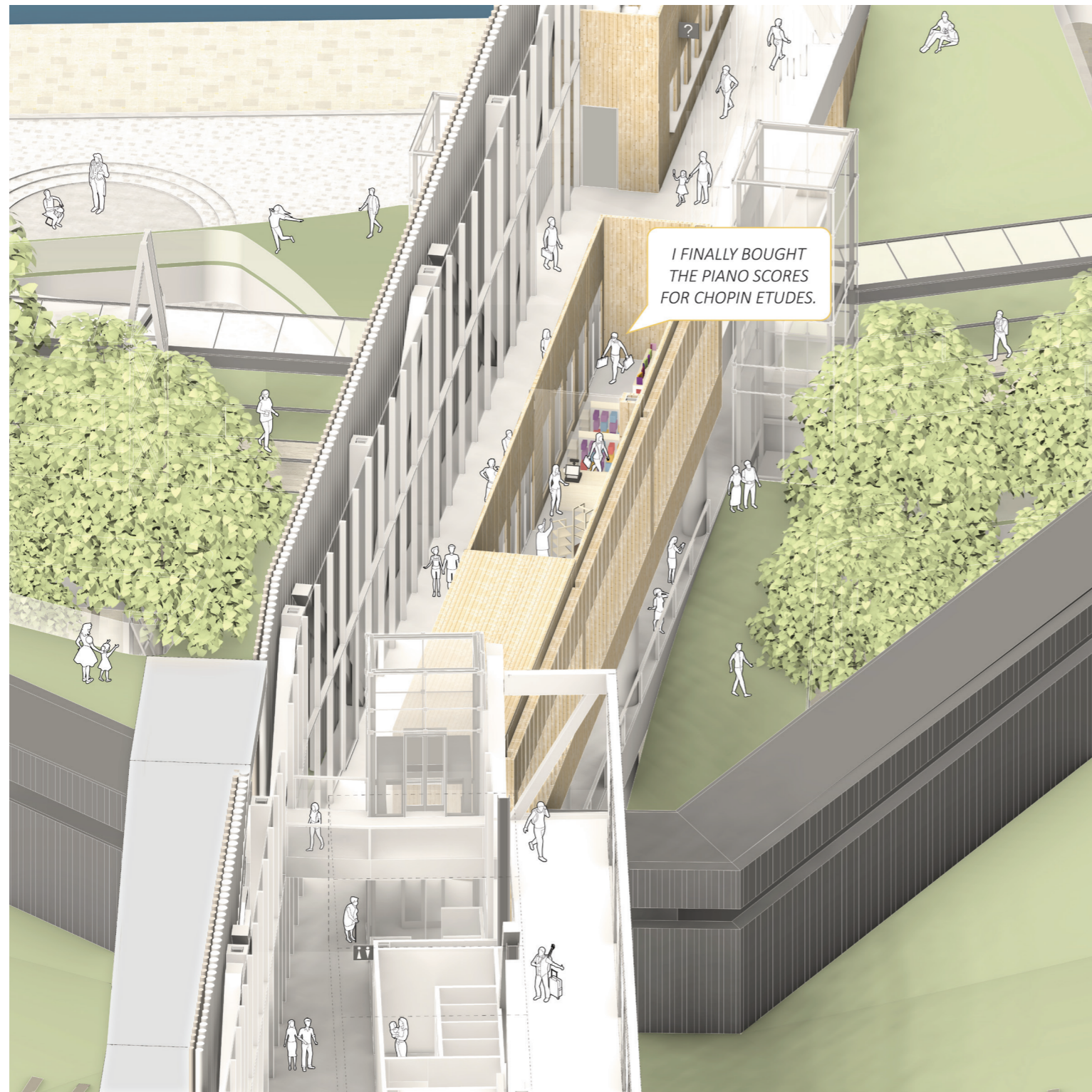

PUBLIC CORRIDOR - RETREAT STATION

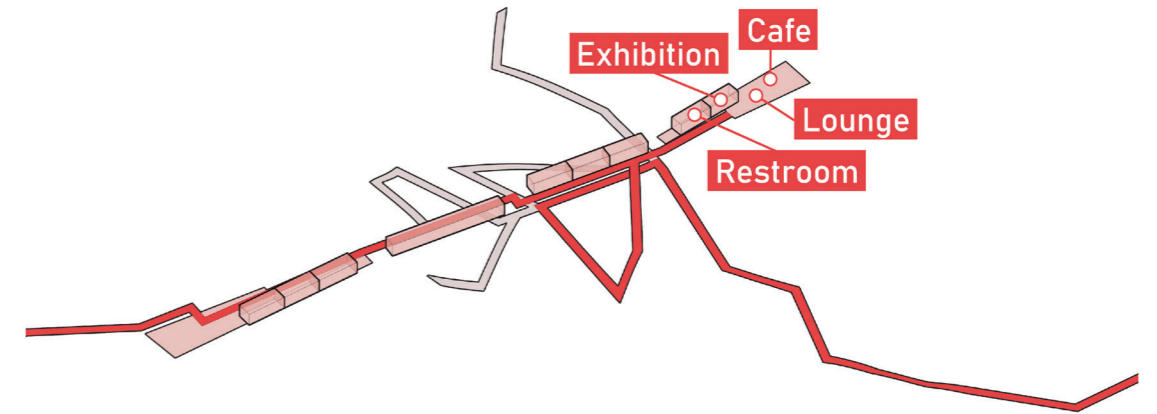
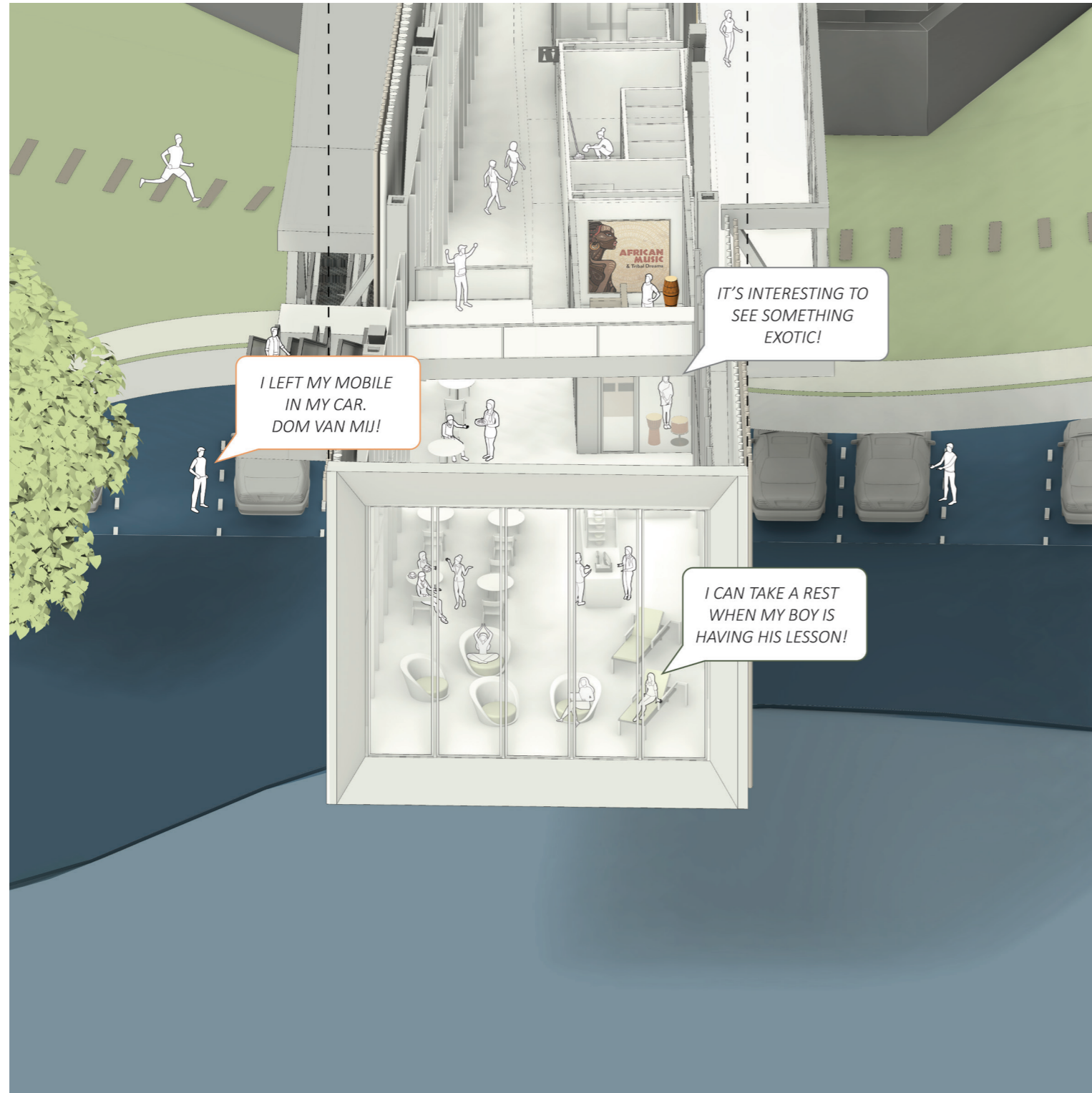

PUBLIC CORRIDOR - NATURAL EXTENSION

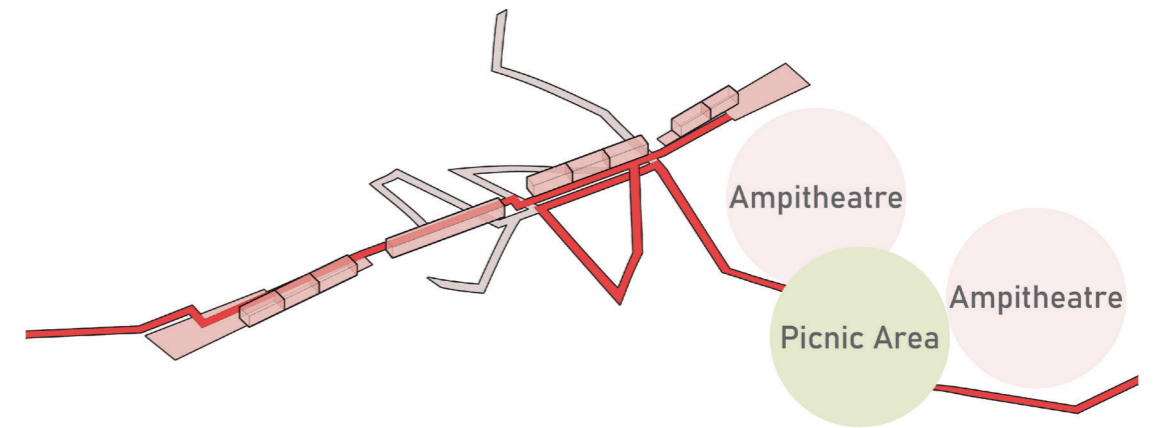
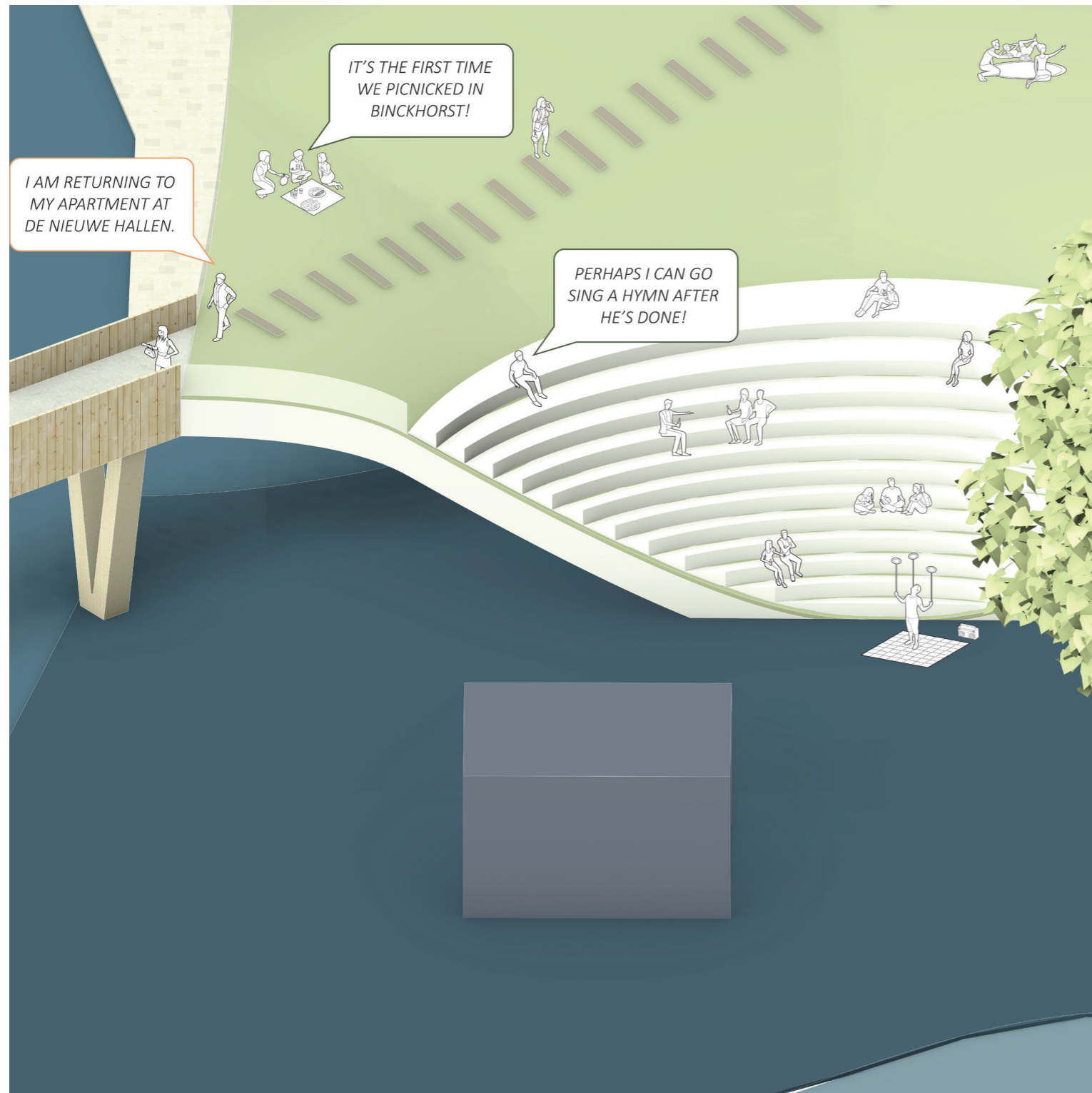

PUBLIC CORRIDOR - PROJECTED USAGE

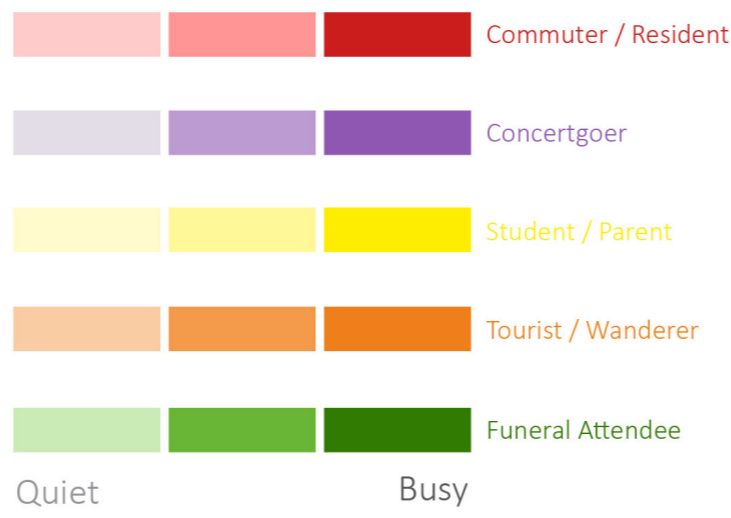
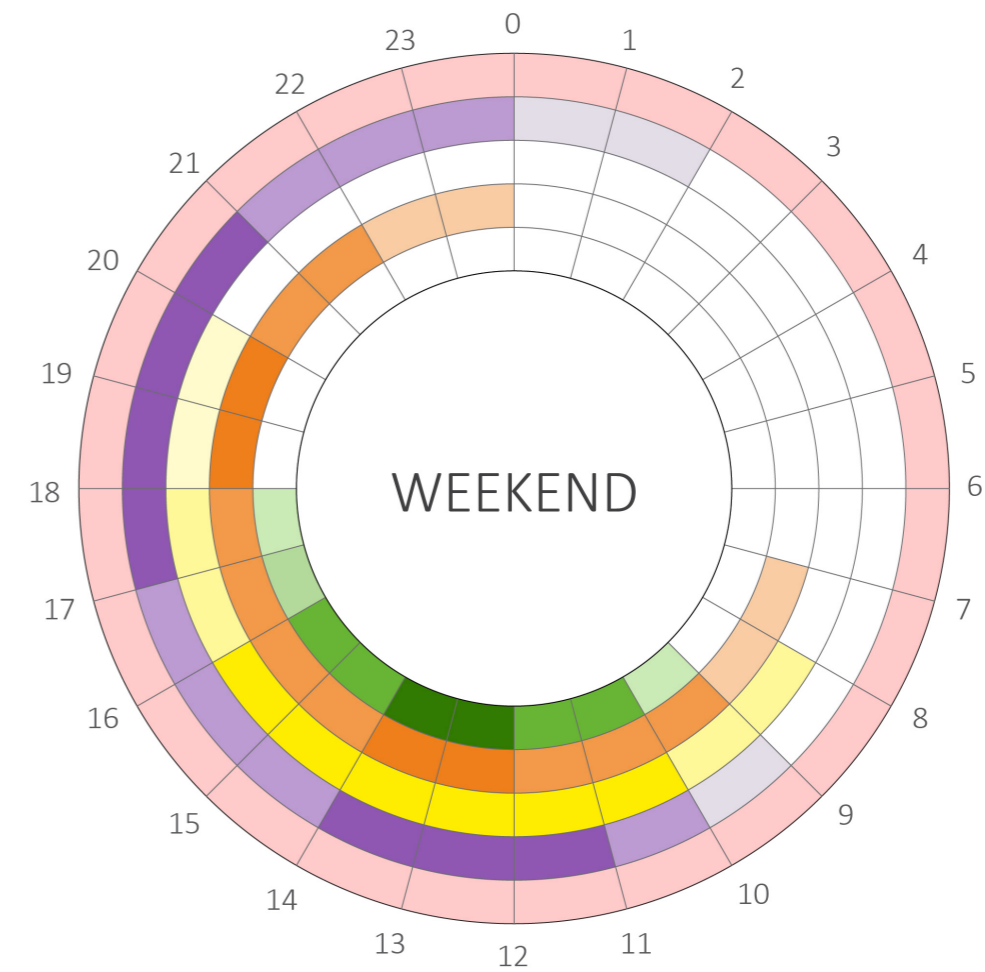
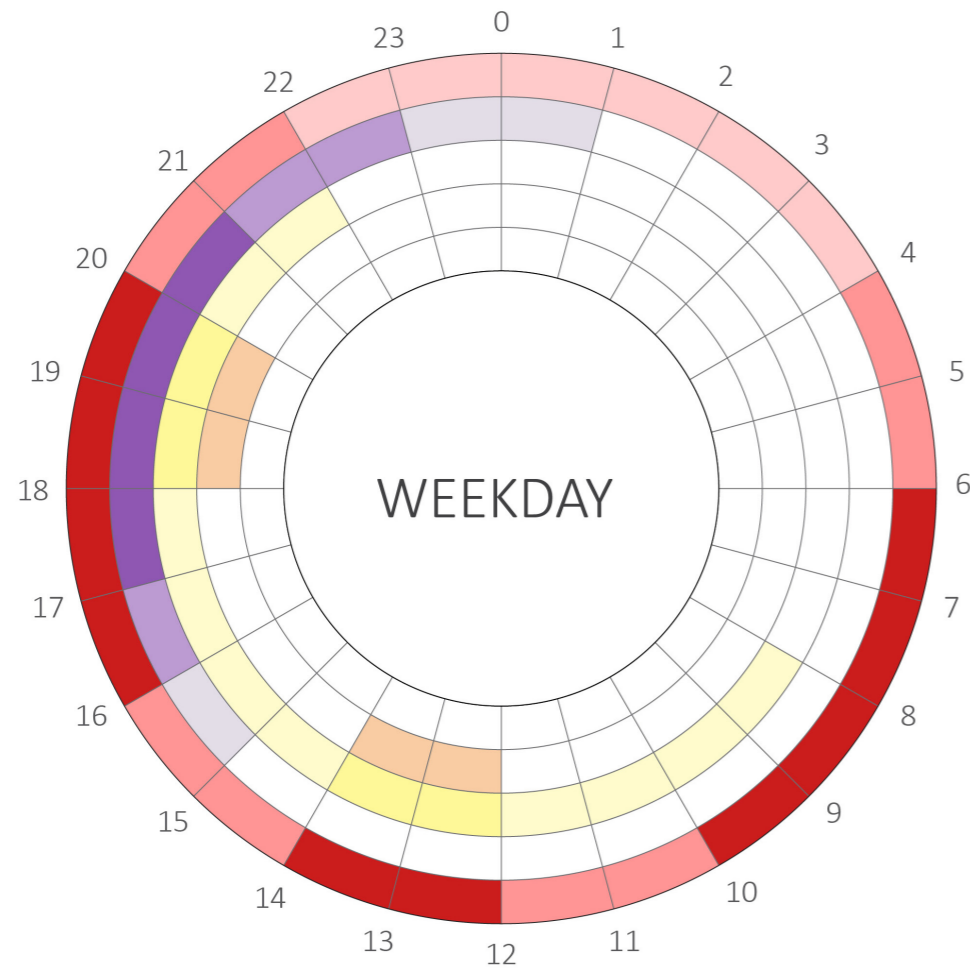

CONCERT LOOP

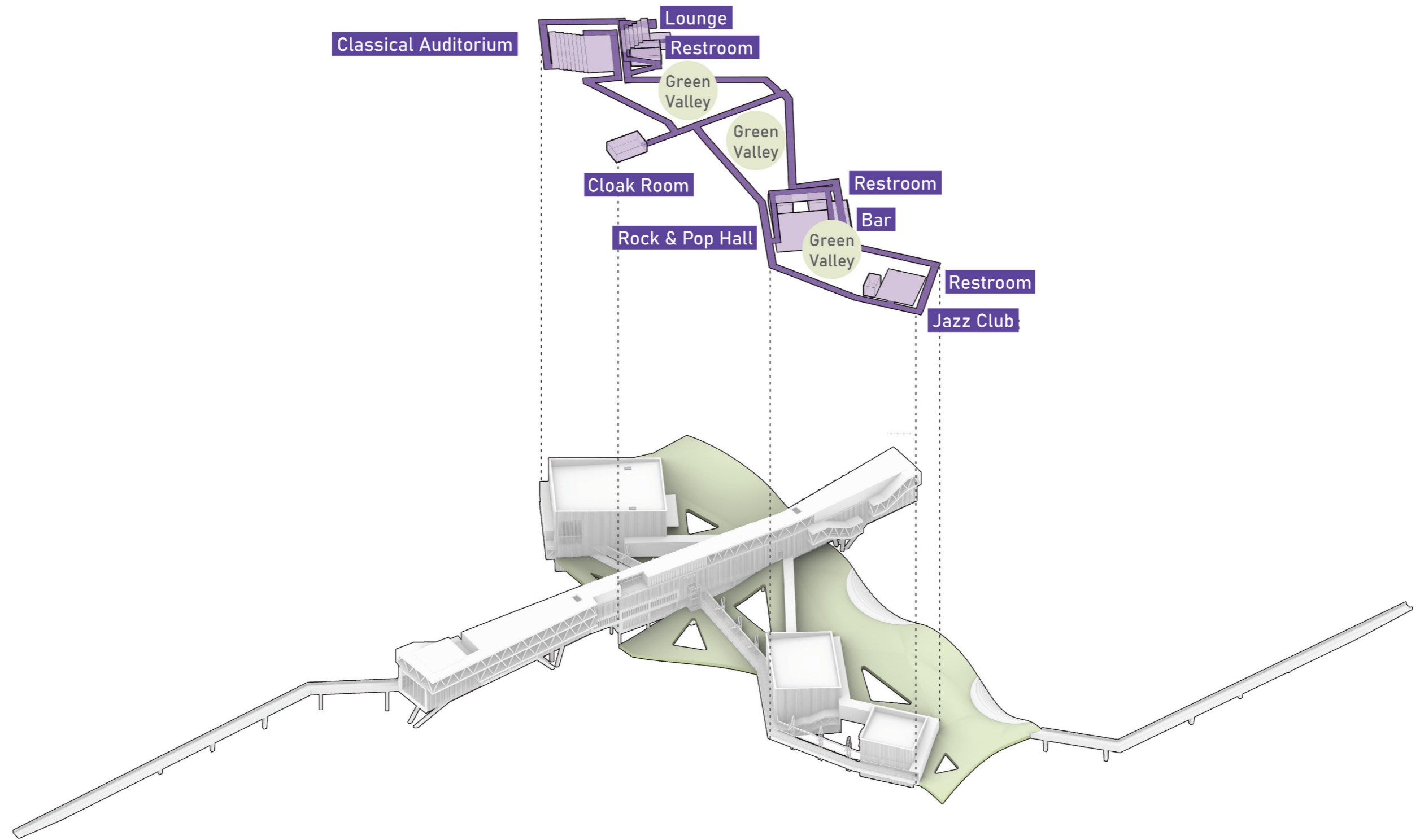

CONCERT LOOP - PUBLICNESS

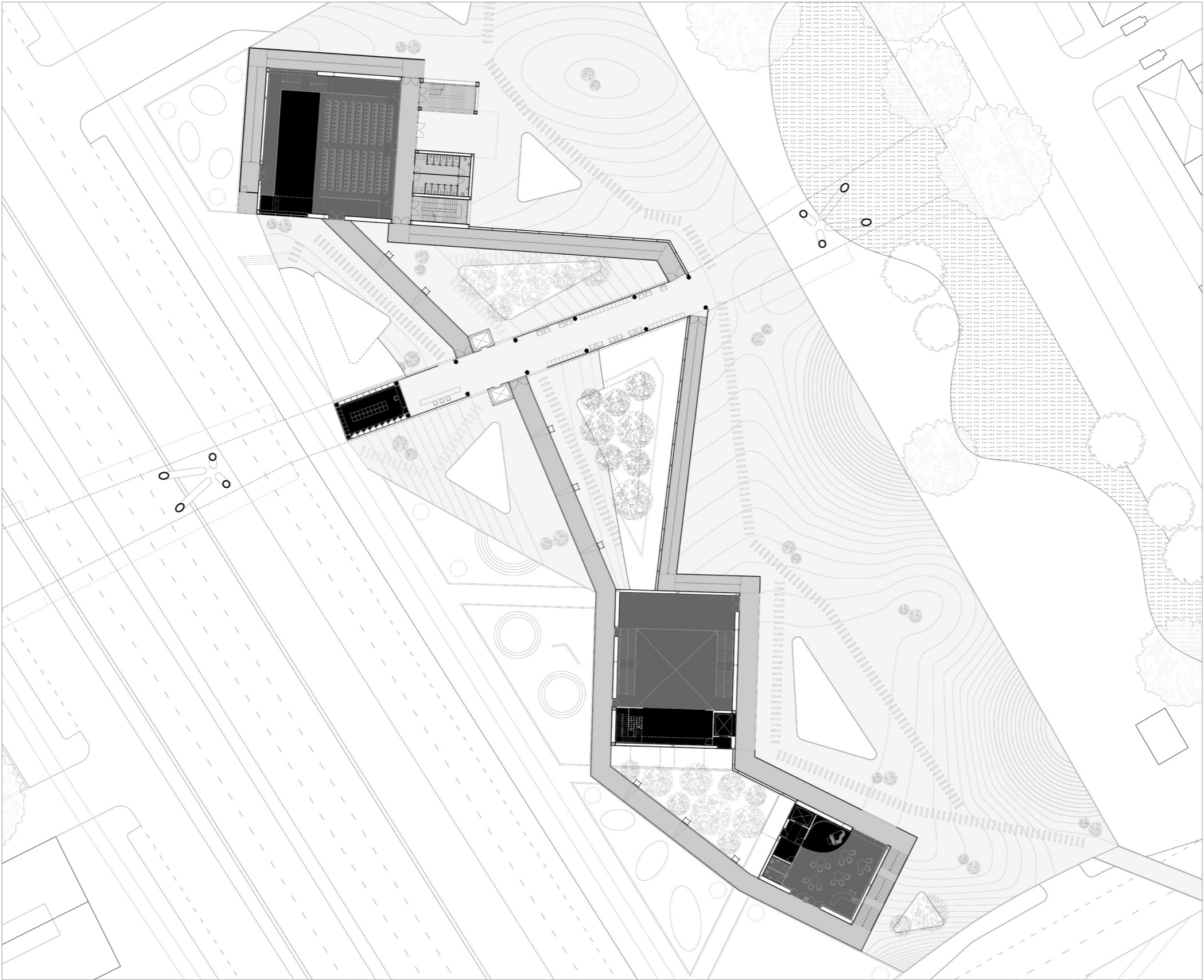

- Staff / Performers Only
- Concert Halls
- Ticketed Areas
- 24/7 Access

CONCERT LOOP - PRELUDE I CODA

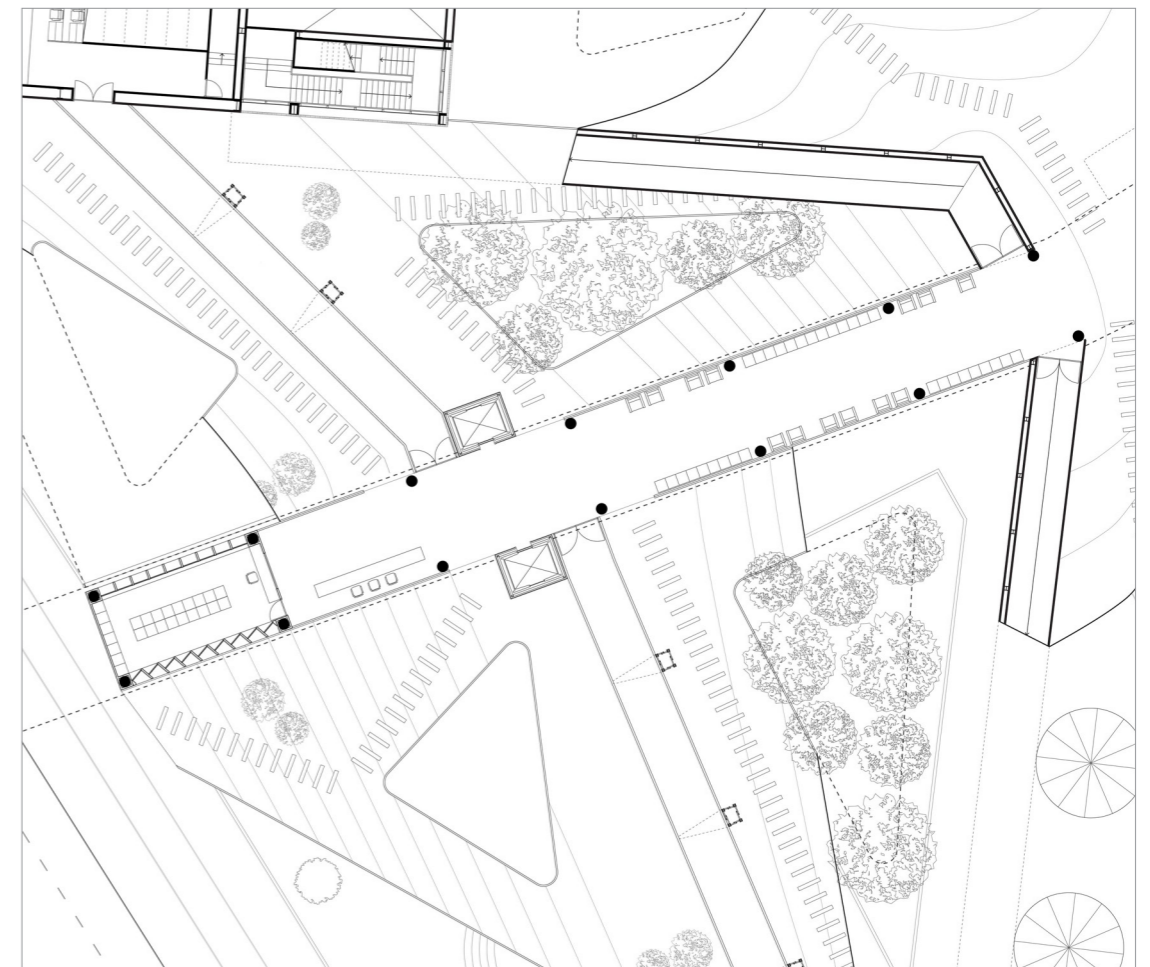
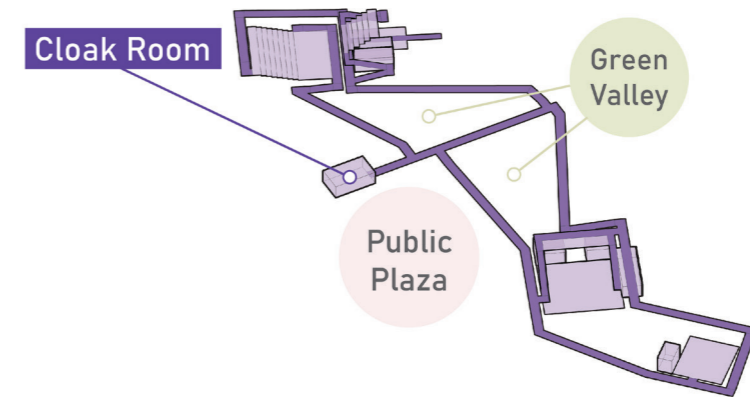
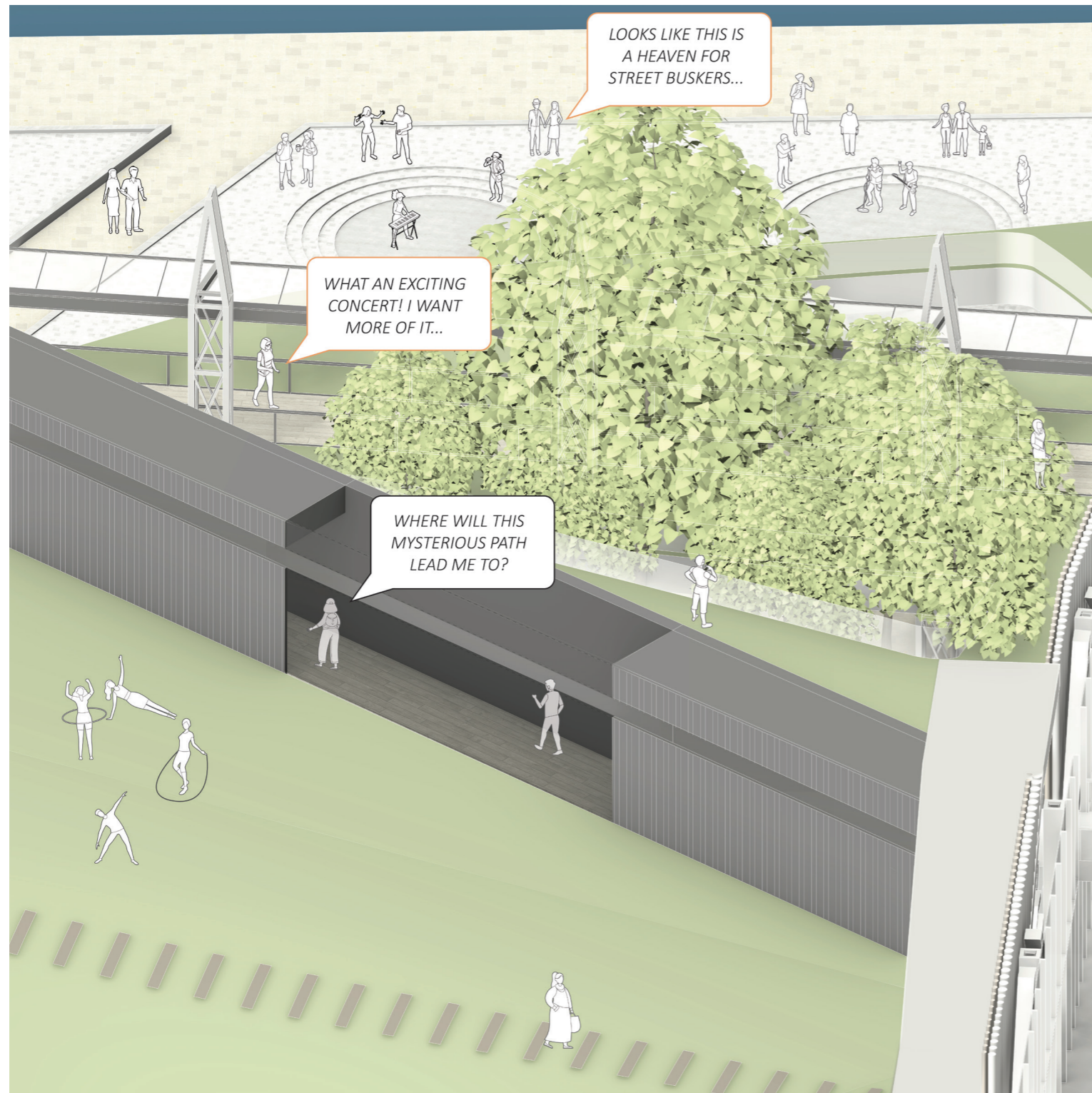

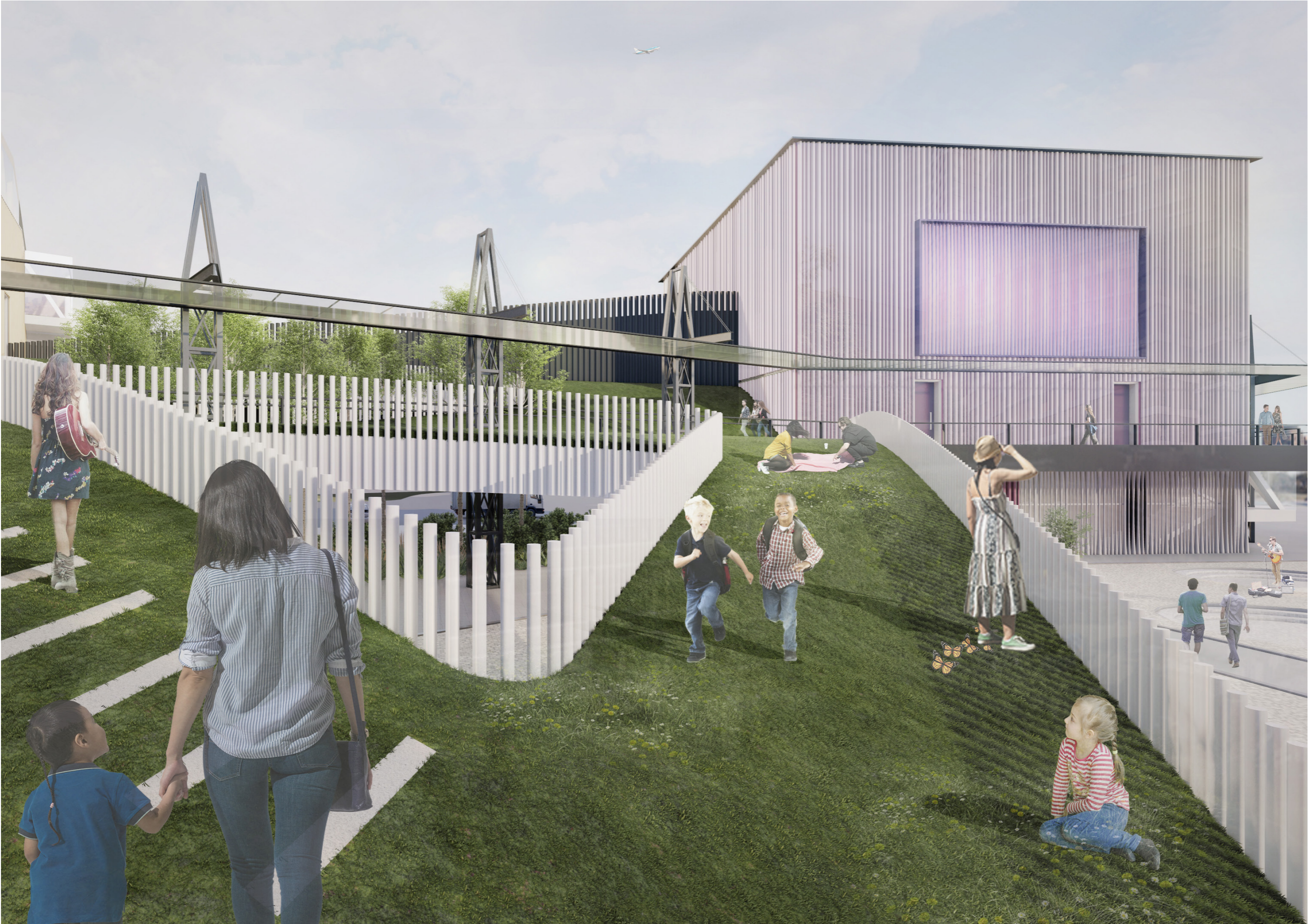

CONCERT LOOP - MEET MY MUSIC MARVEL

Louis Vuitton Foundation Auditorium

Frank Gehry (2014)

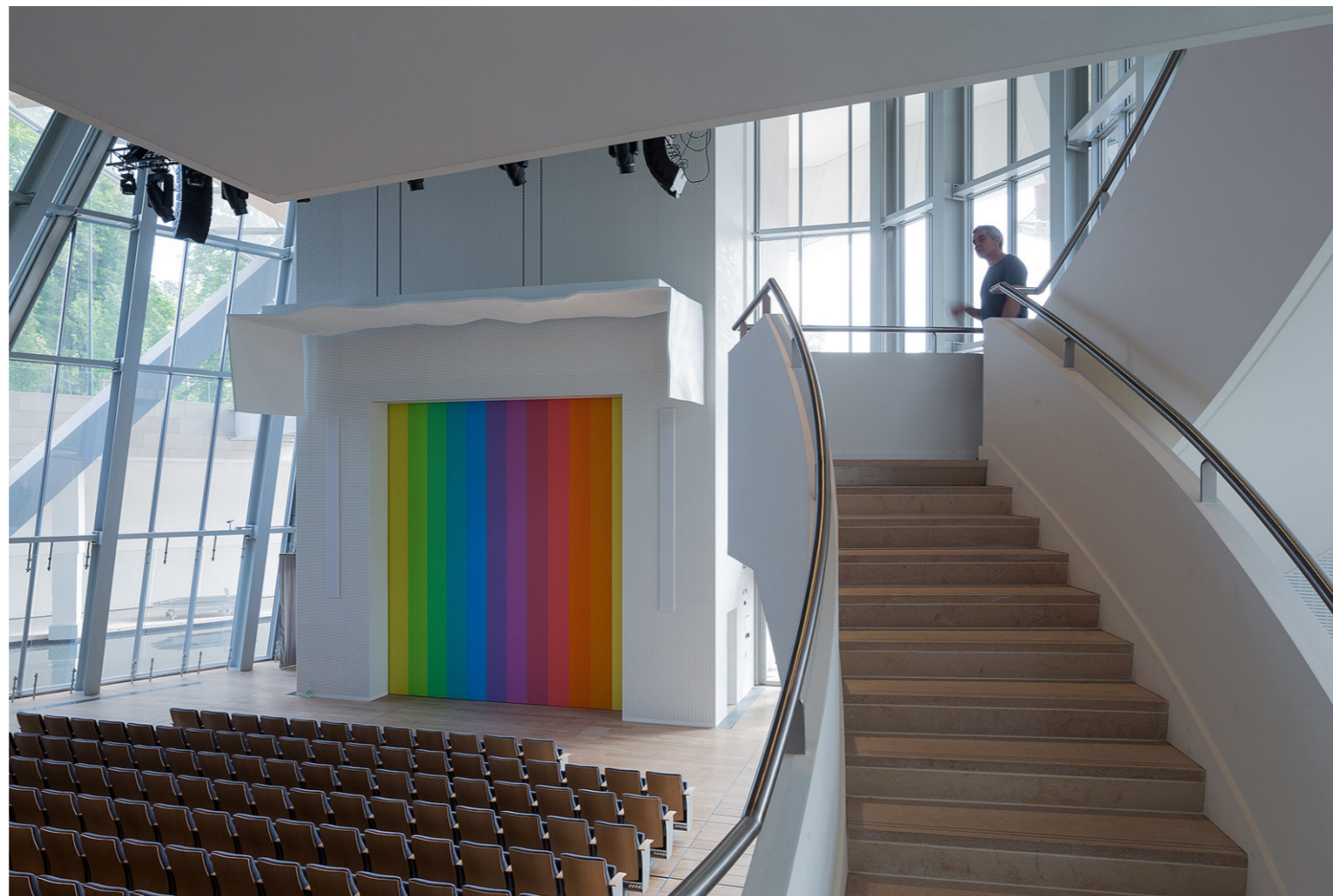

CONCERT LOOP - LINES AND BOXES

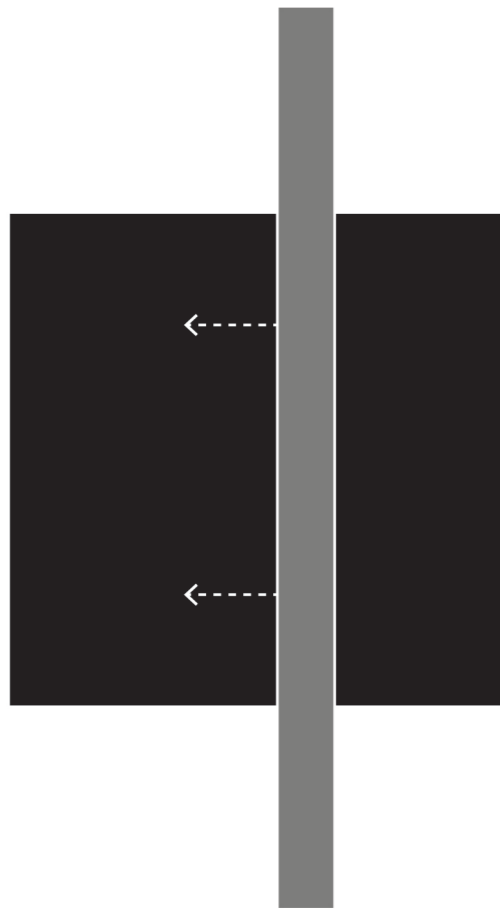

Cut-through

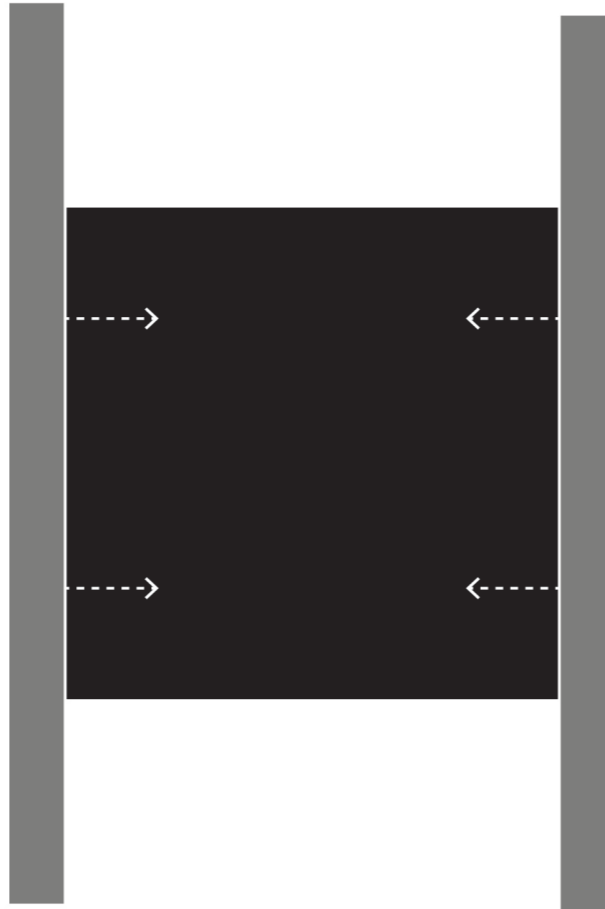

Flank

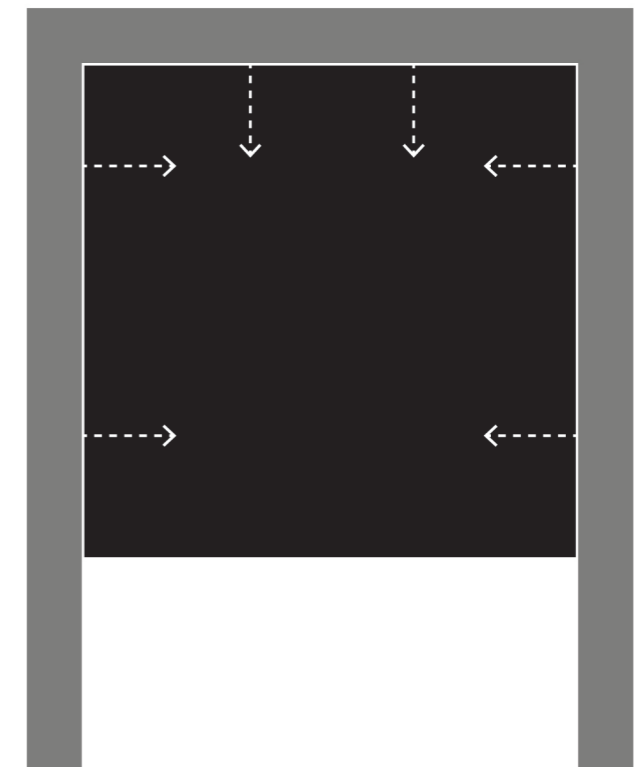

Encircle

CONCERT LOOP - CLASSICAL AUDITORIUM

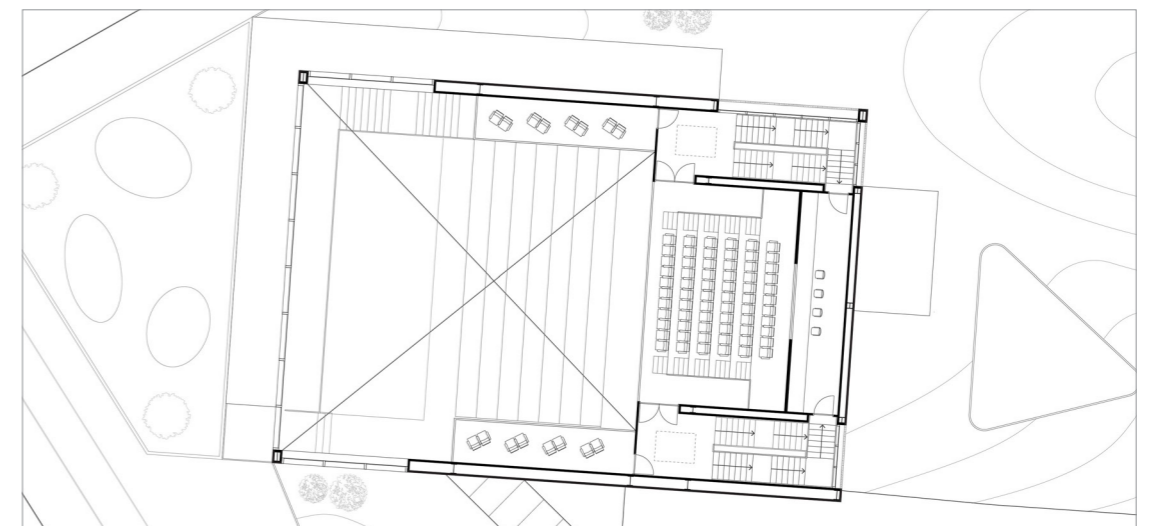
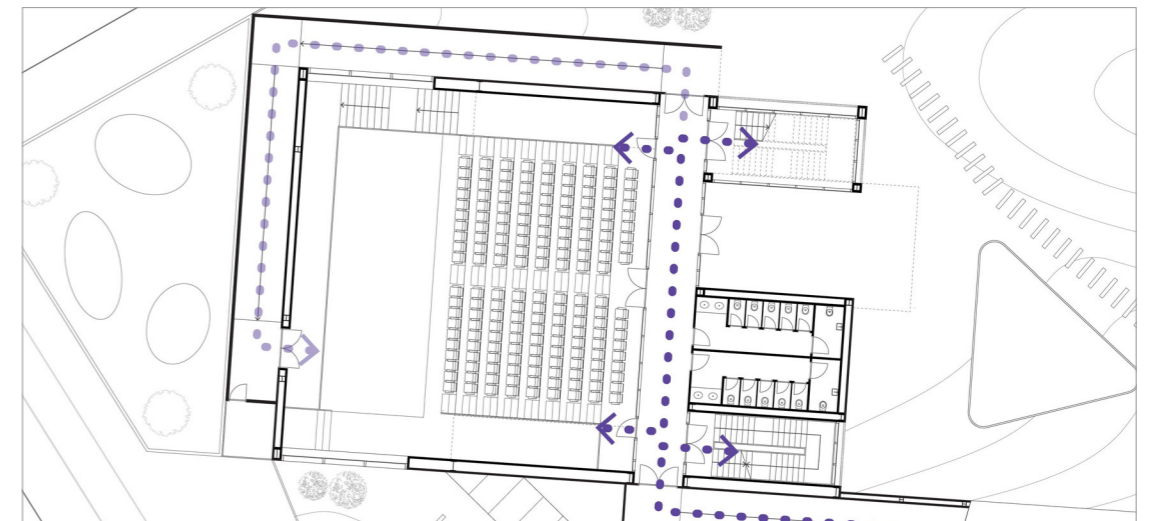
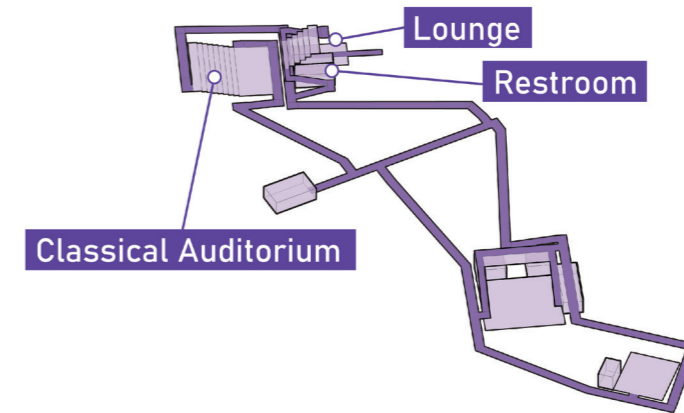
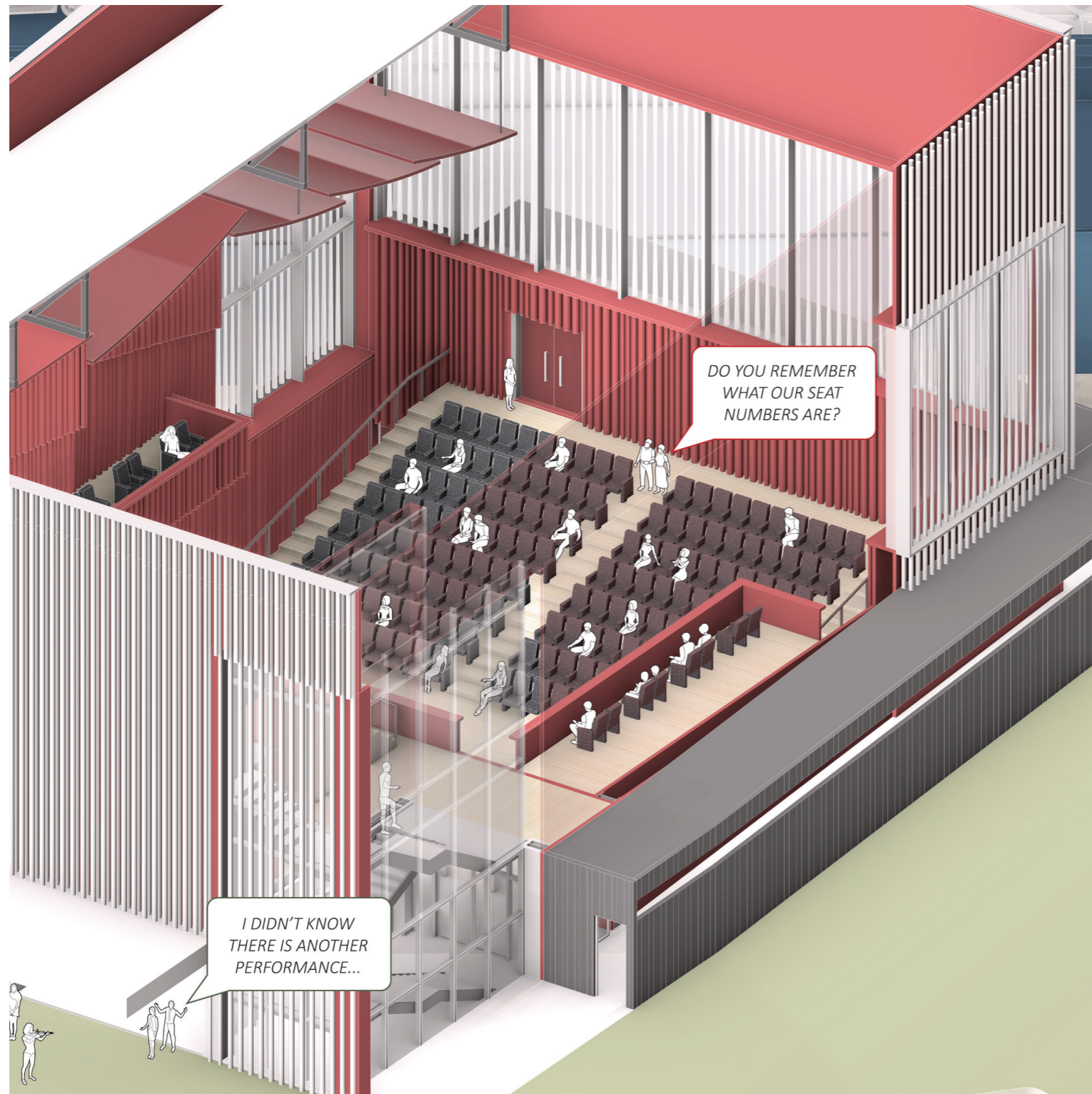

CLASSICAL AUDITORIUM

MULTIPLICITY IN CONFIGURATION | USE

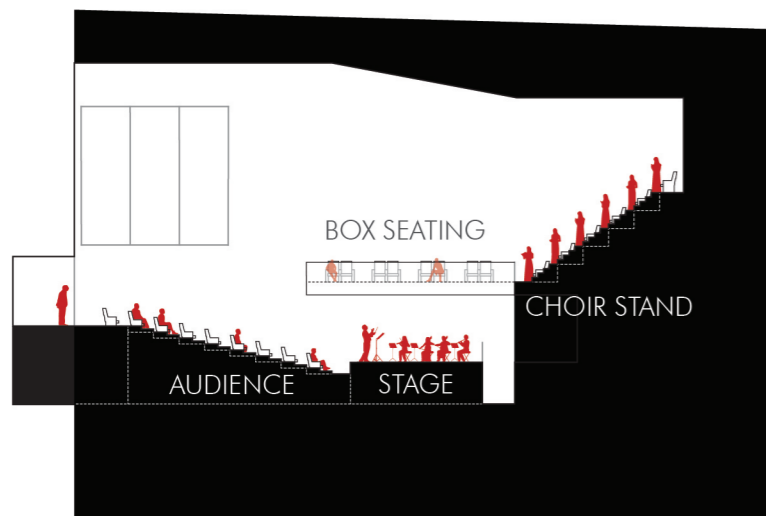

Larger Total Stage Area

Opera / Musical

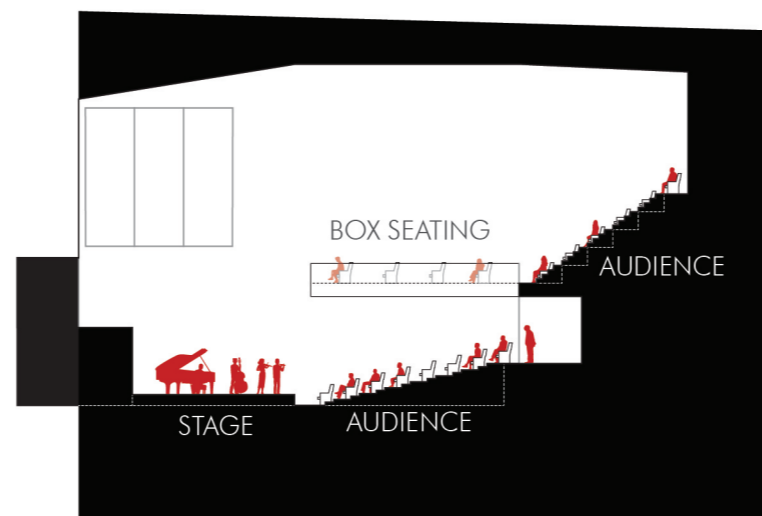

Highest Audience Capacity

Symphony / Recital

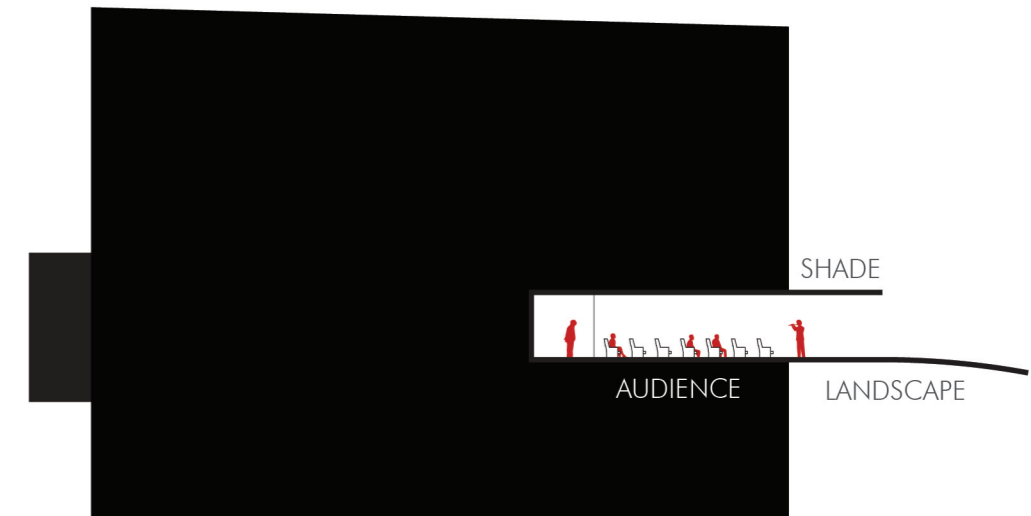

Minimal Formality

Lunchtime Concert



CONCERT LOOP - ROCK & POP HALL

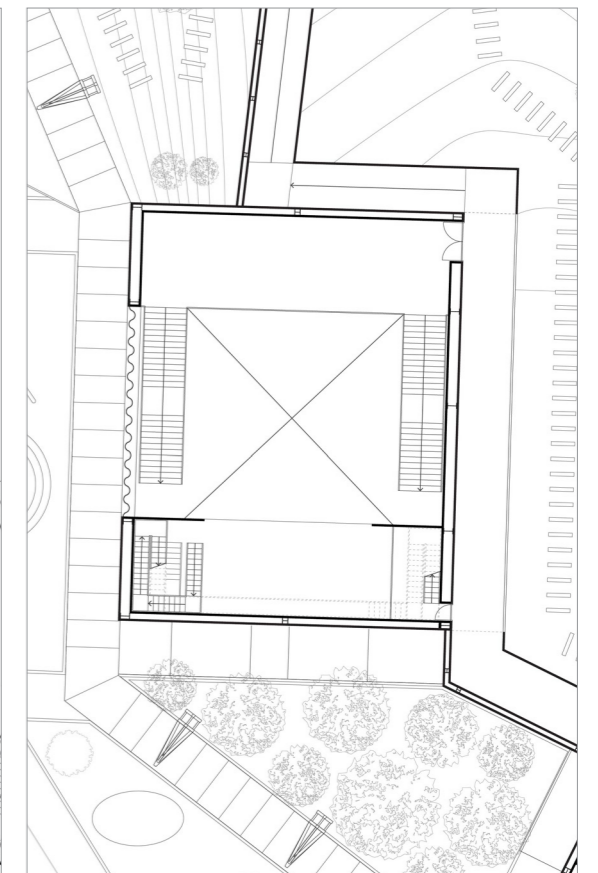
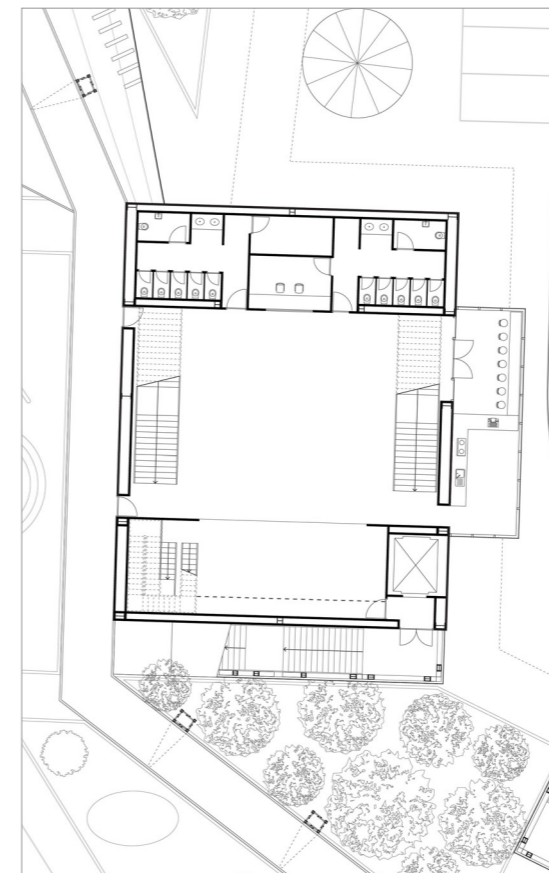
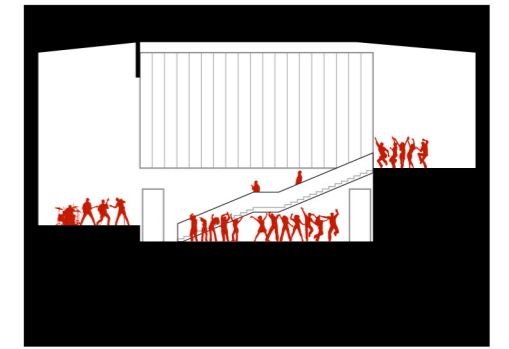
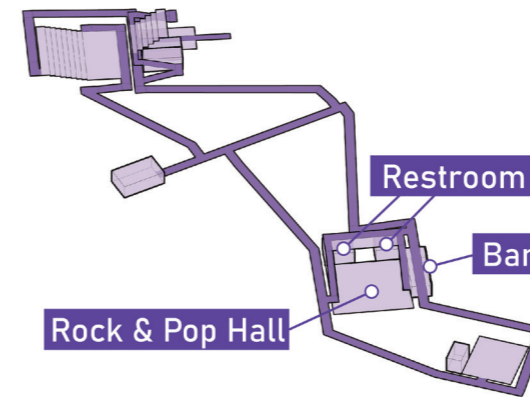
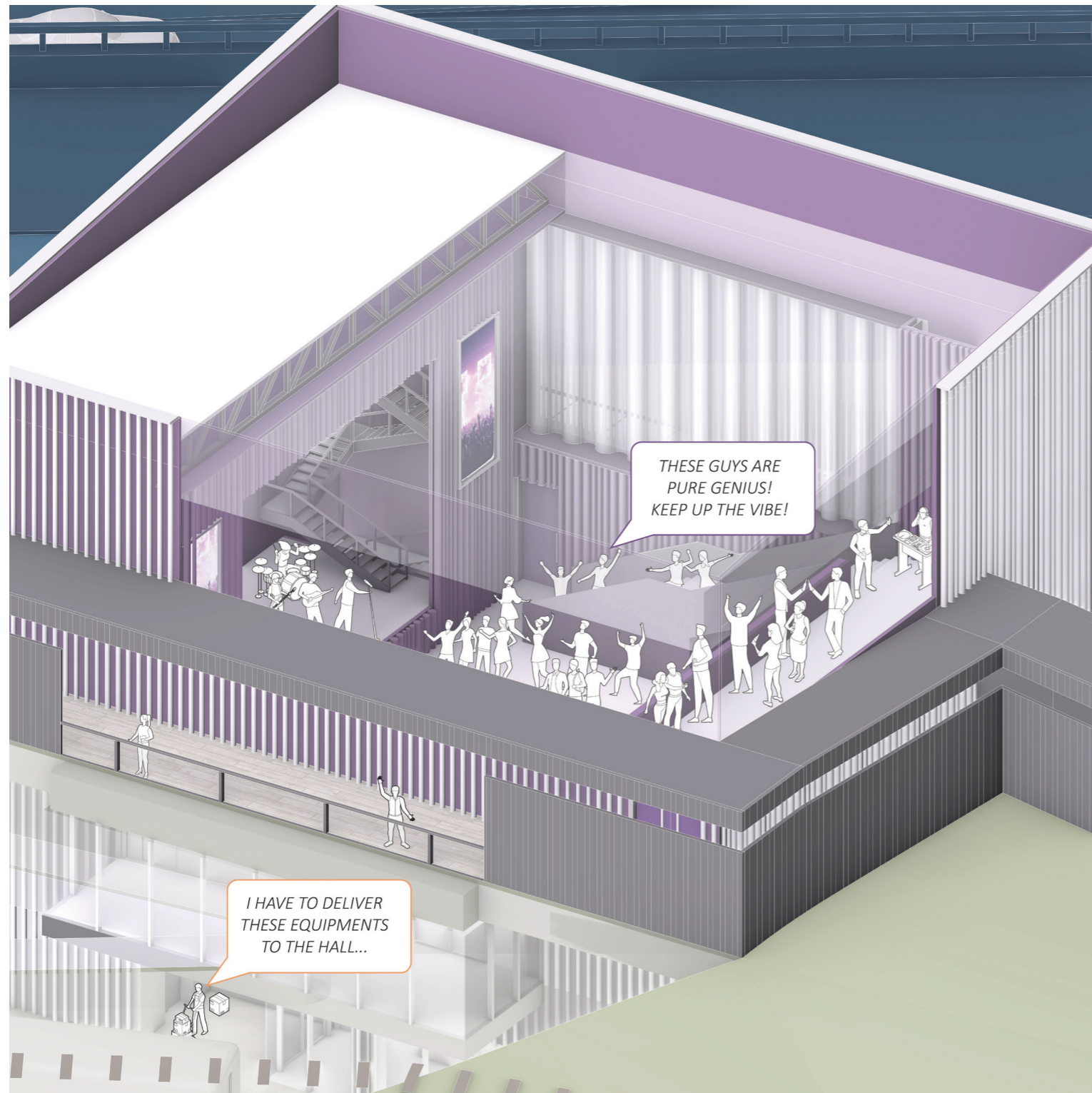



CONCERT LOOP - JAZZ CLUB

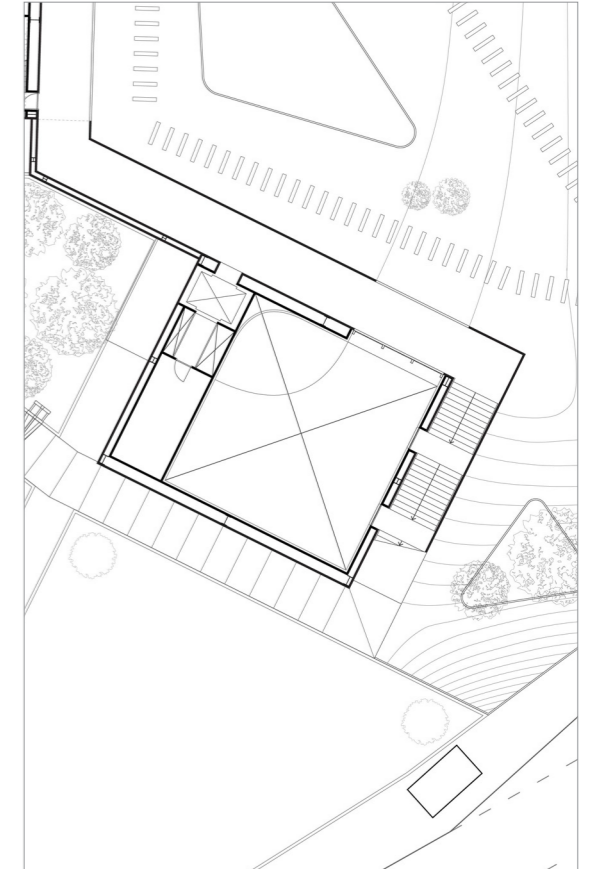
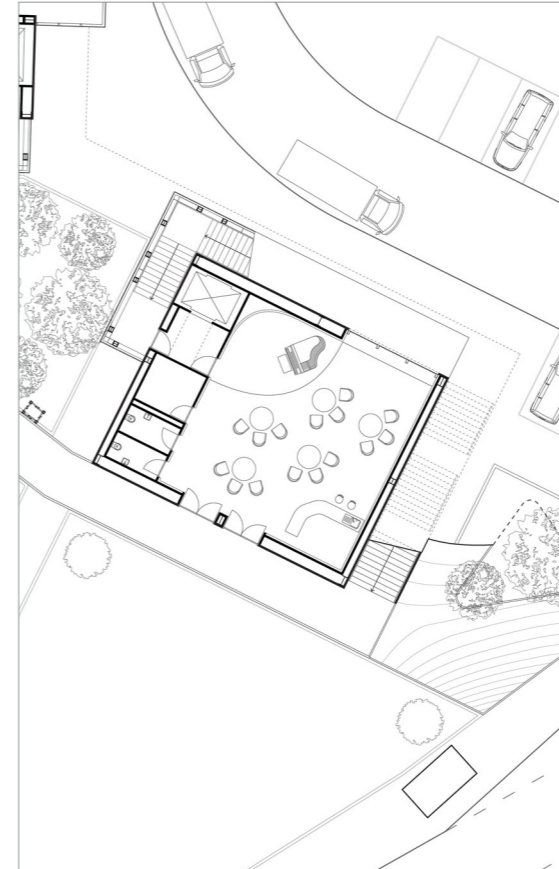
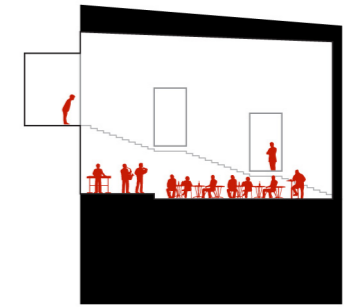
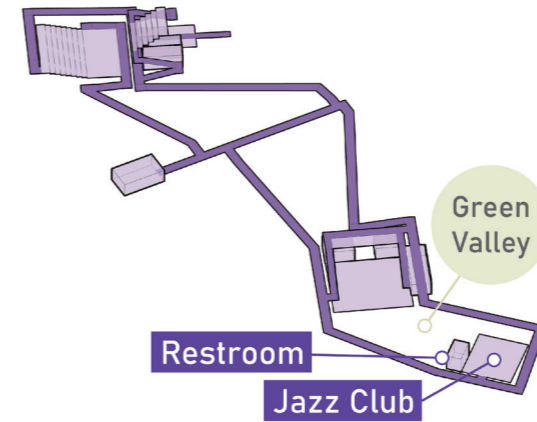
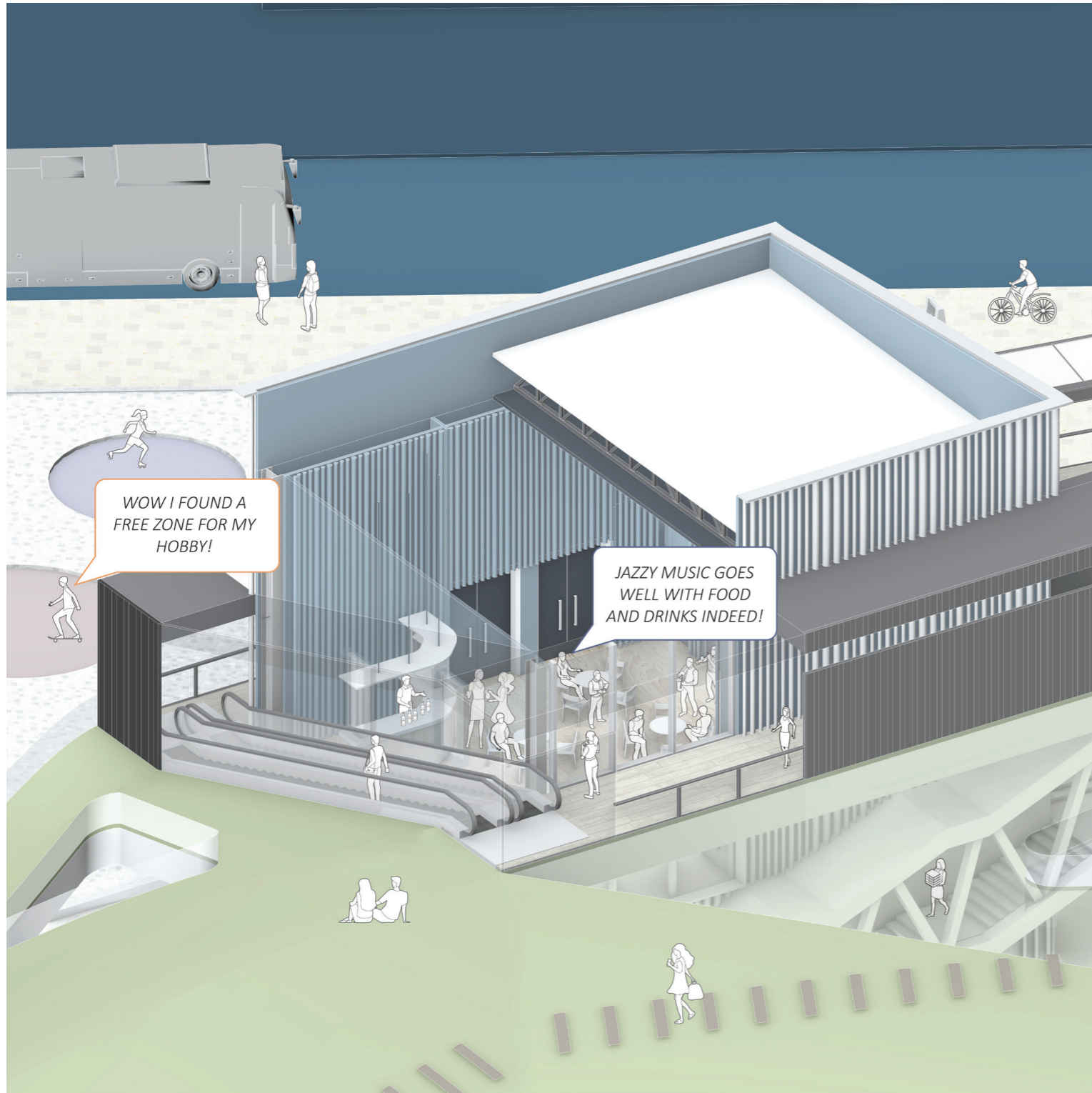



STREETS OF EDUCATION

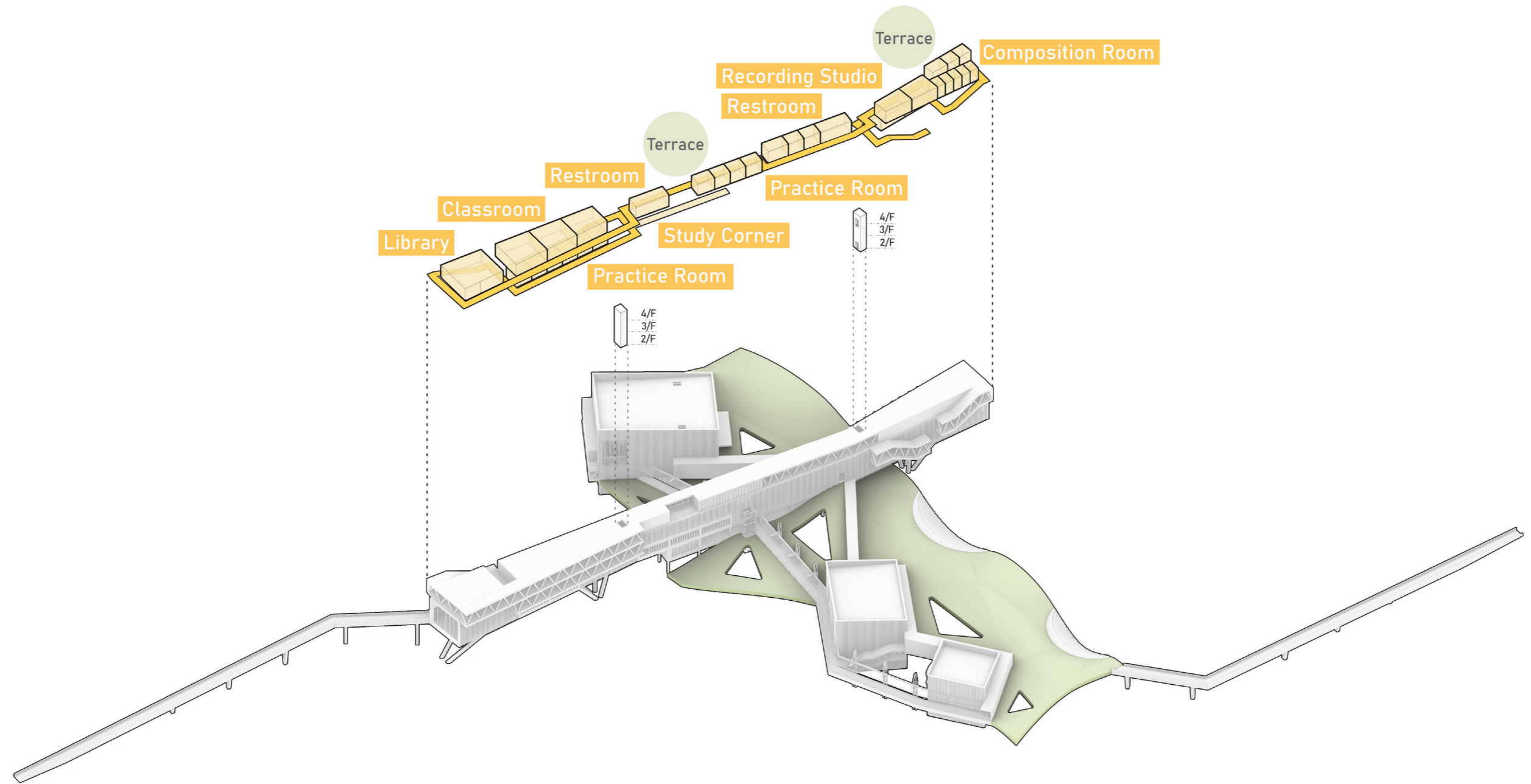

MUSIC SCHOOL - KNOWLEDGE HAVEN

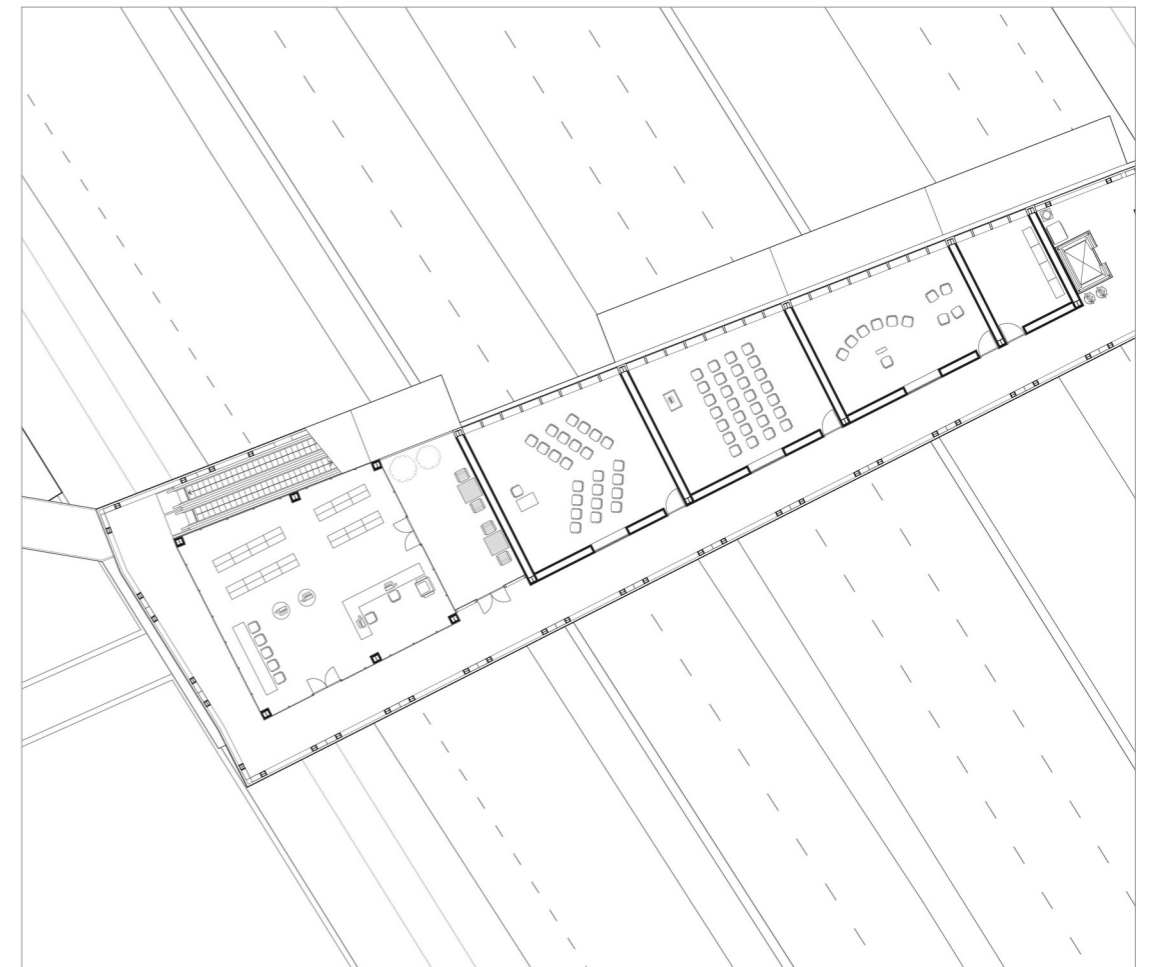
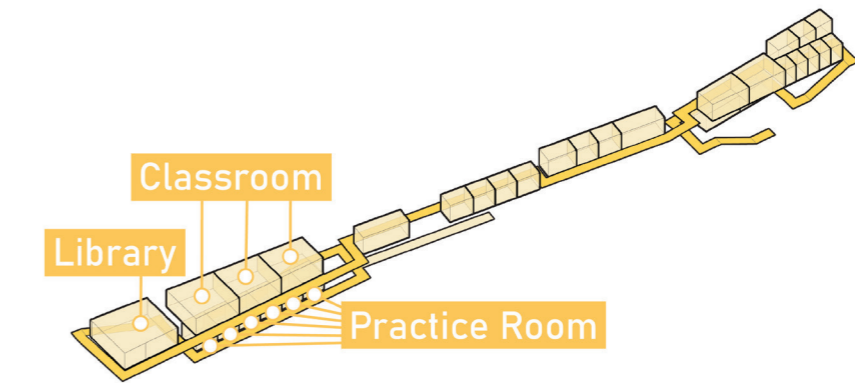

MUSIC SCHOOL - PRACTICE HOTSPOT

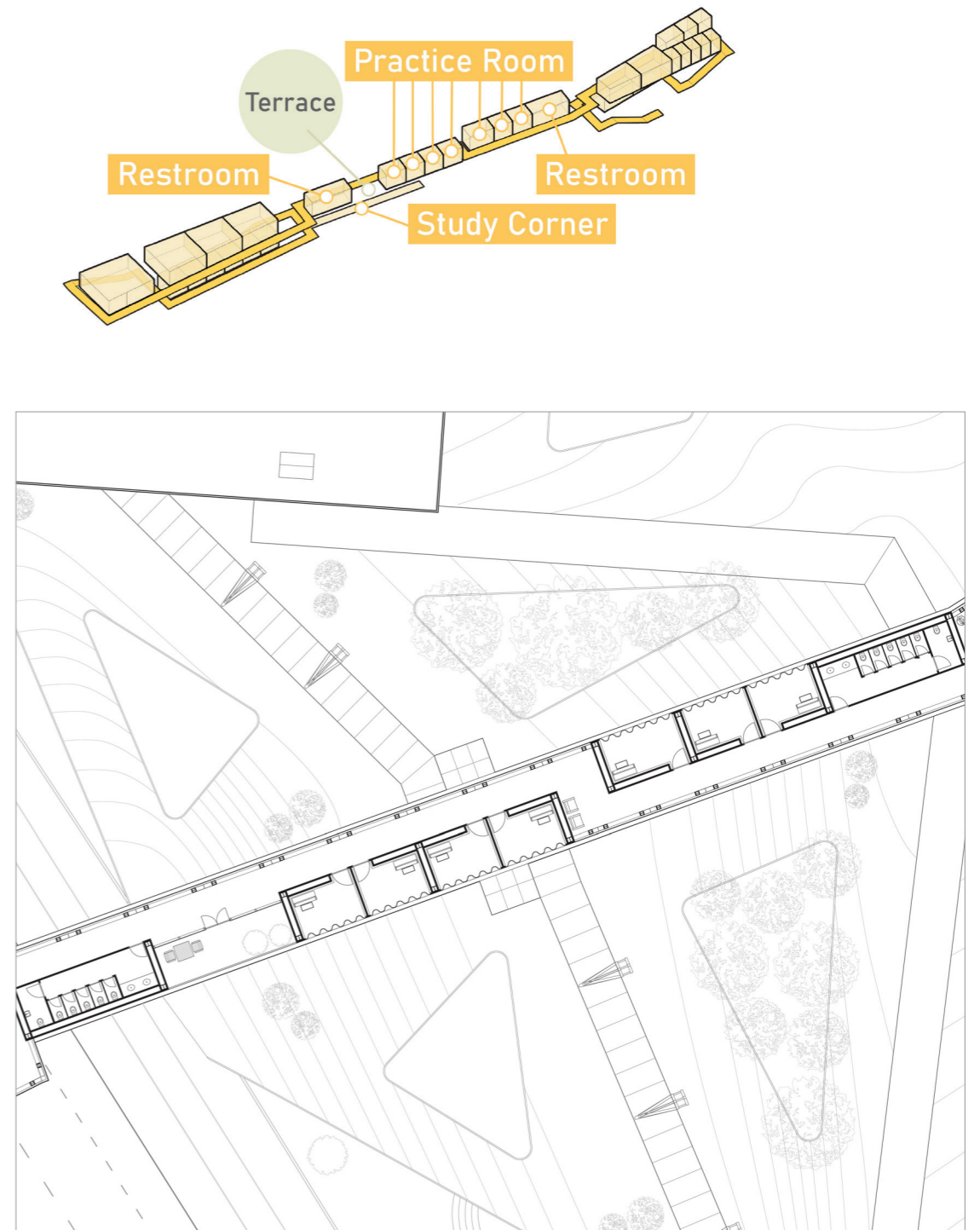

MUSIC SCHOOL - CREATIVITY CRADLE

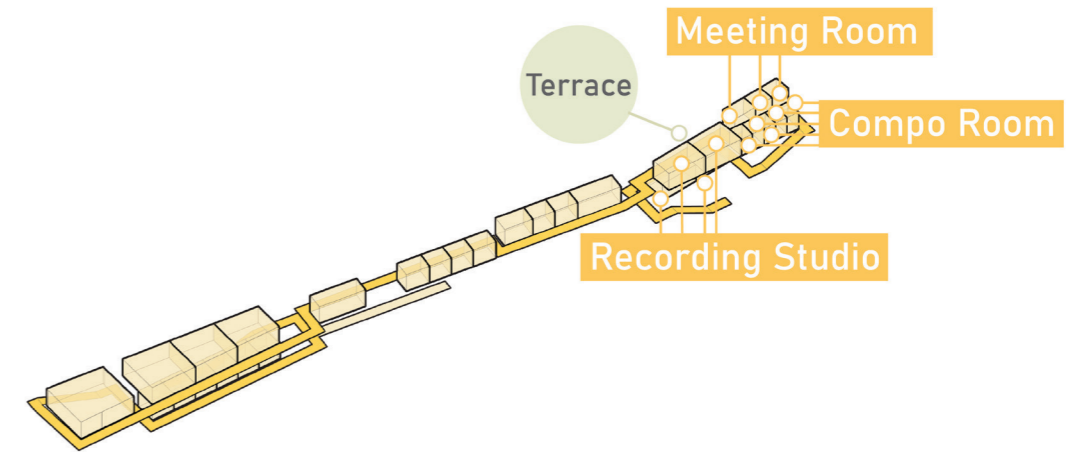
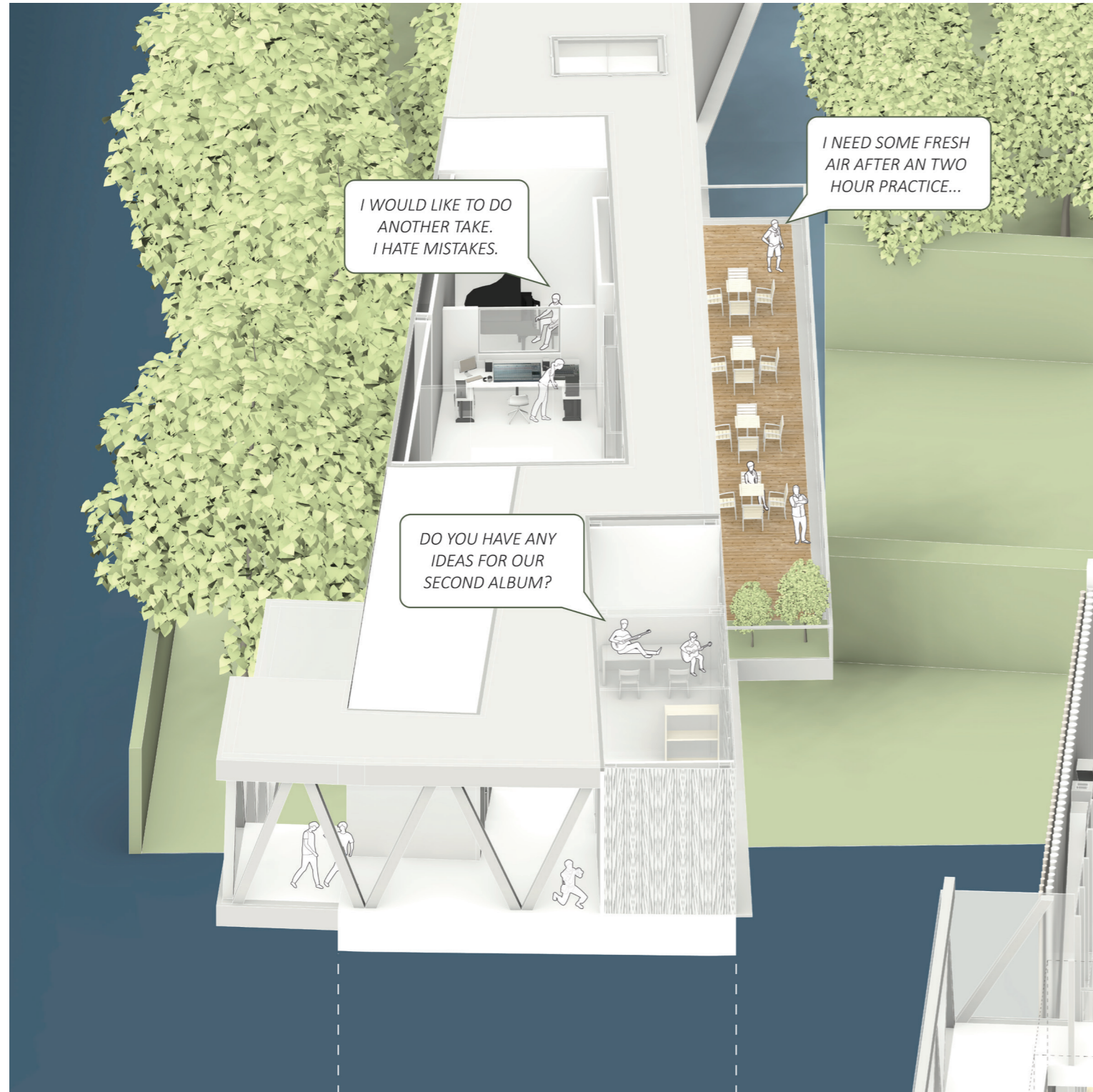

PERFORMER HUB

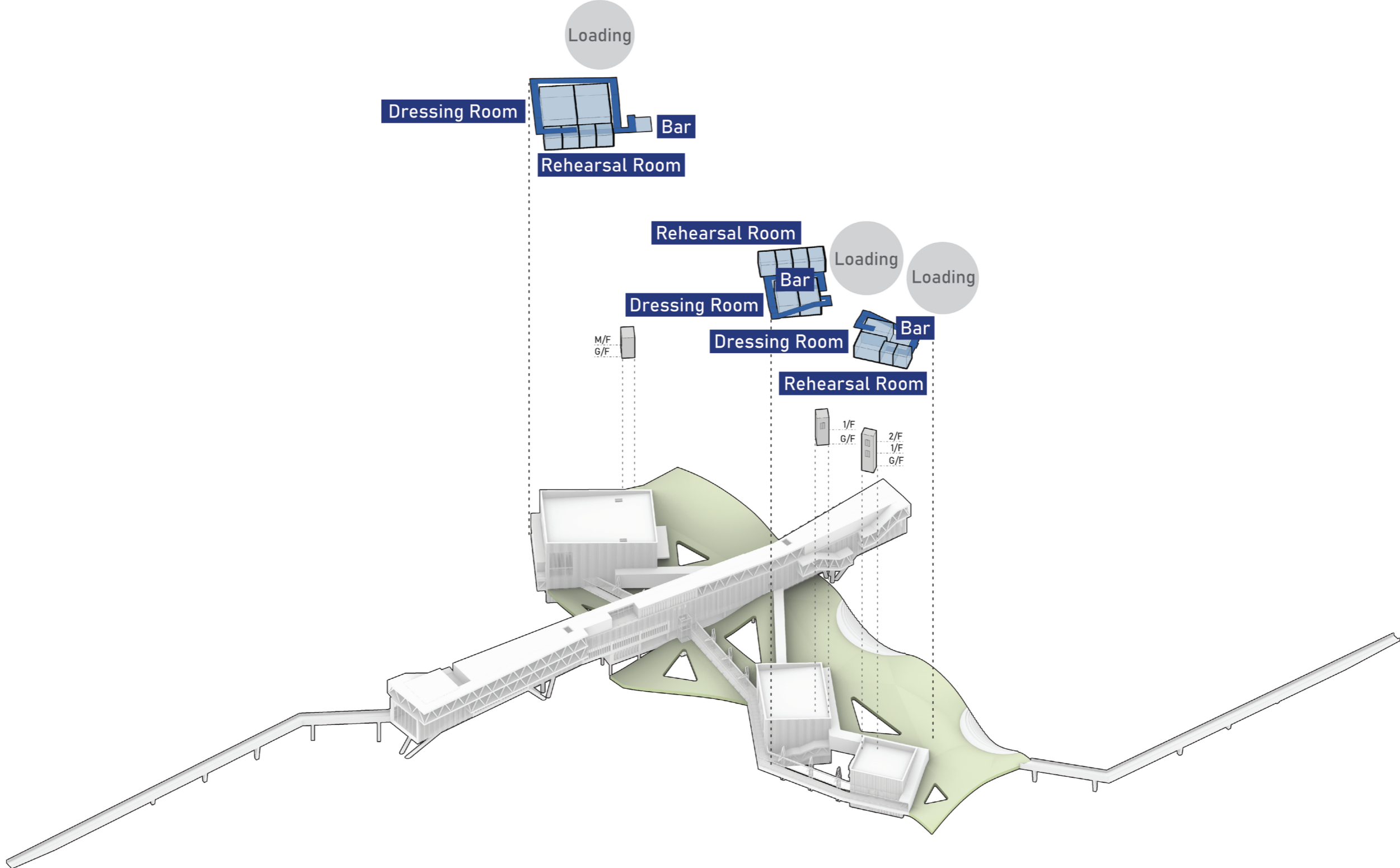

PERFORMER HUB

Classical Auditorium

Rock & Pop Hall

Jazz Club

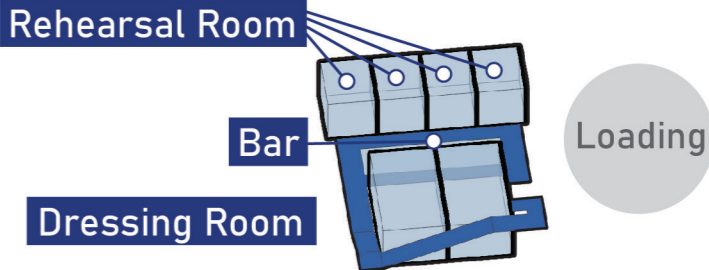
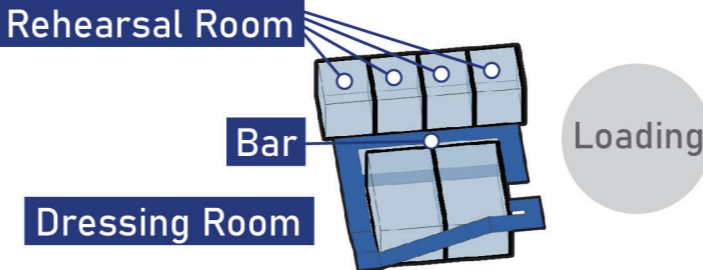
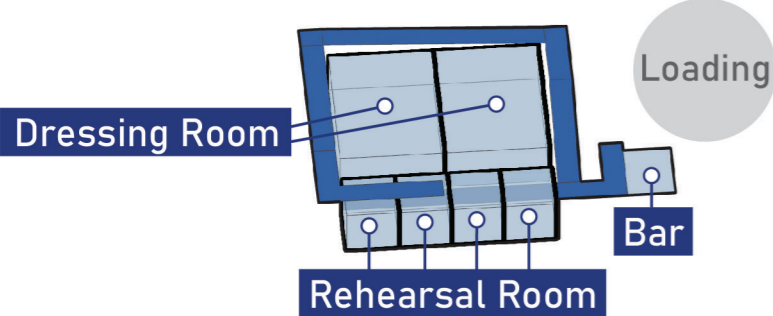
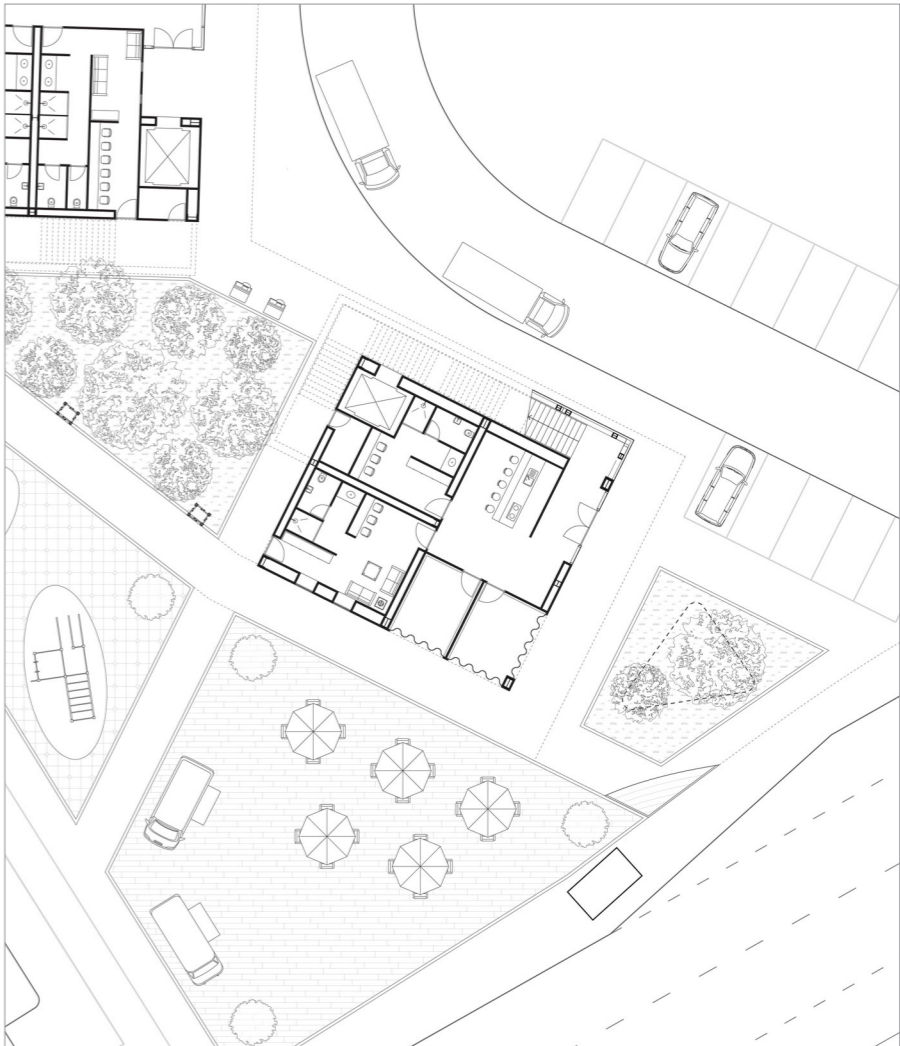
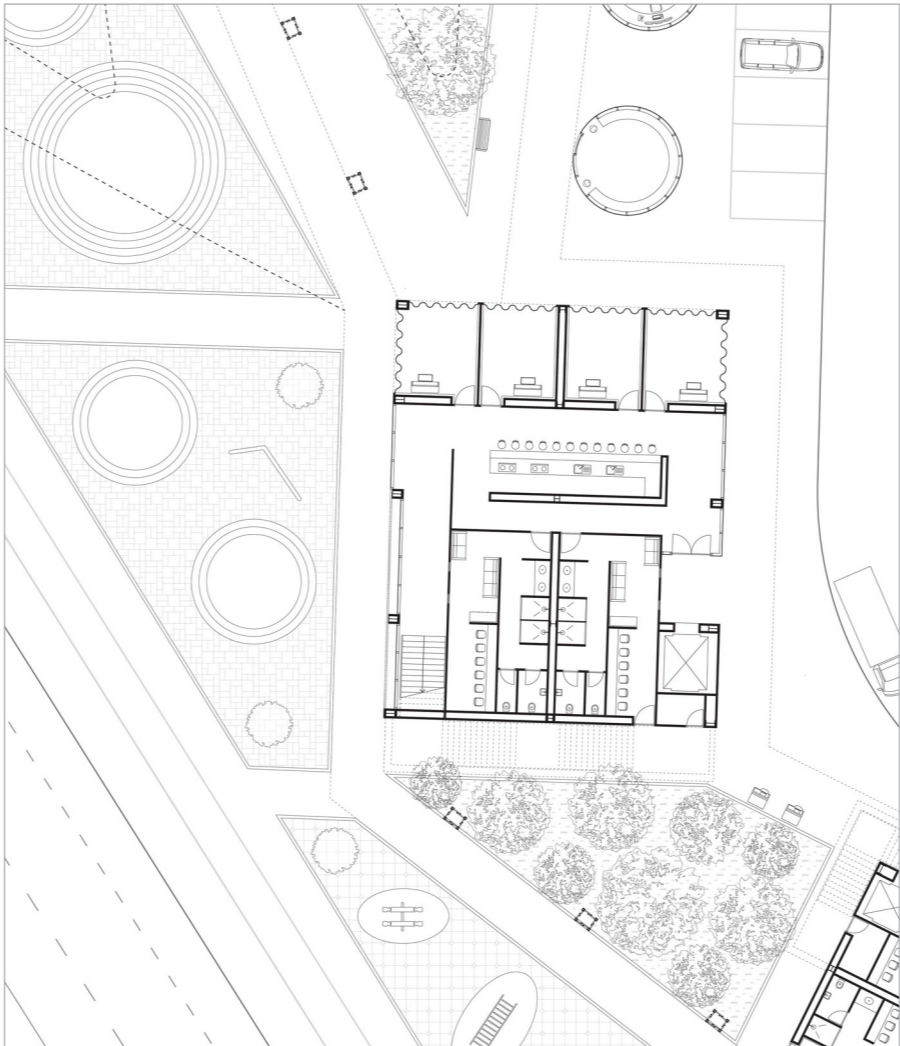
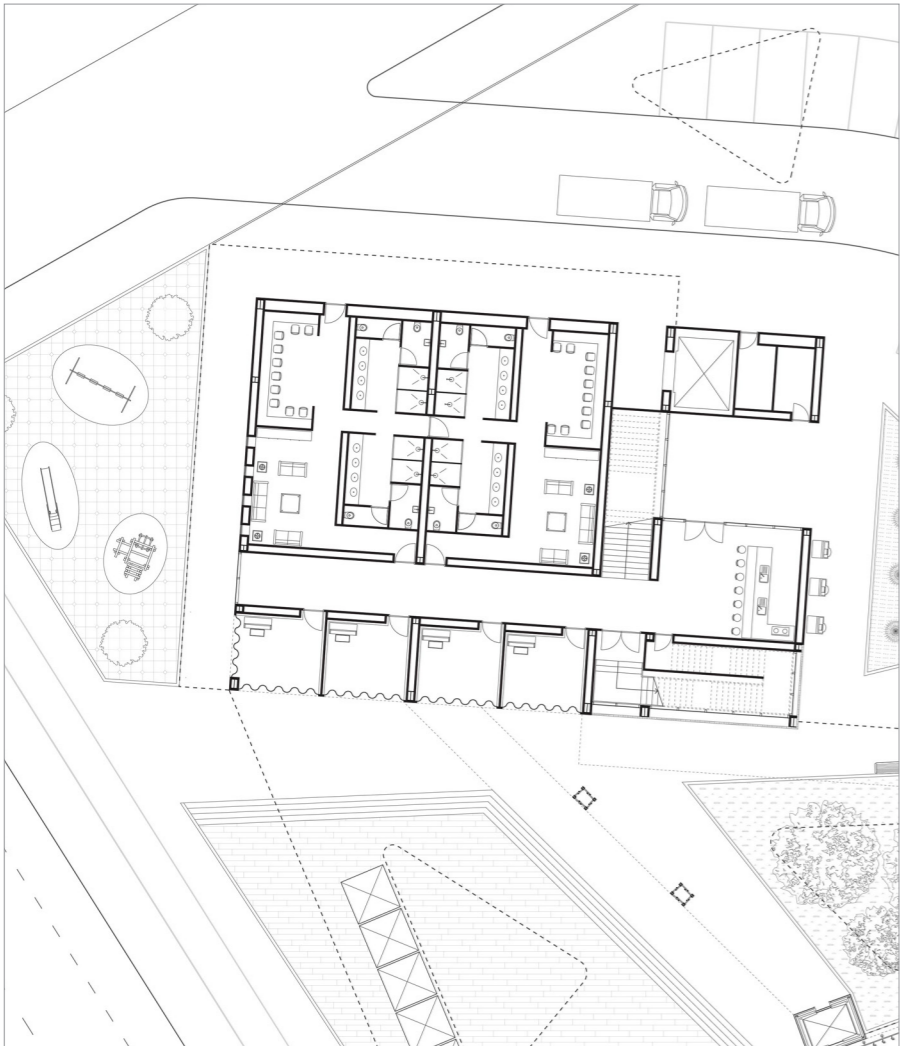

GROUND LEVEL ROUTING - PERFORMER

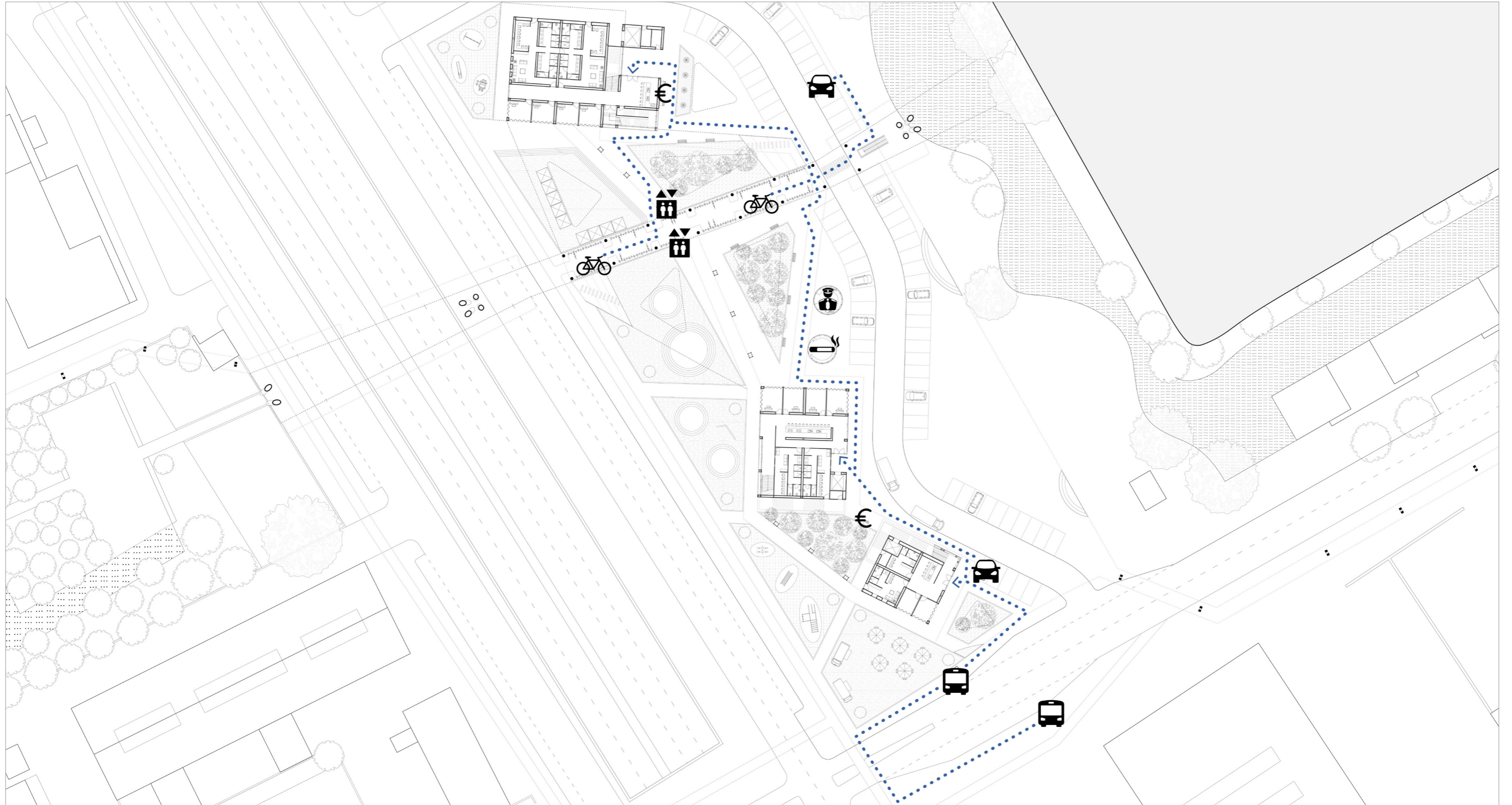

GROUND LEVEL ROUTING - PUBLIC

Arrival By Bus

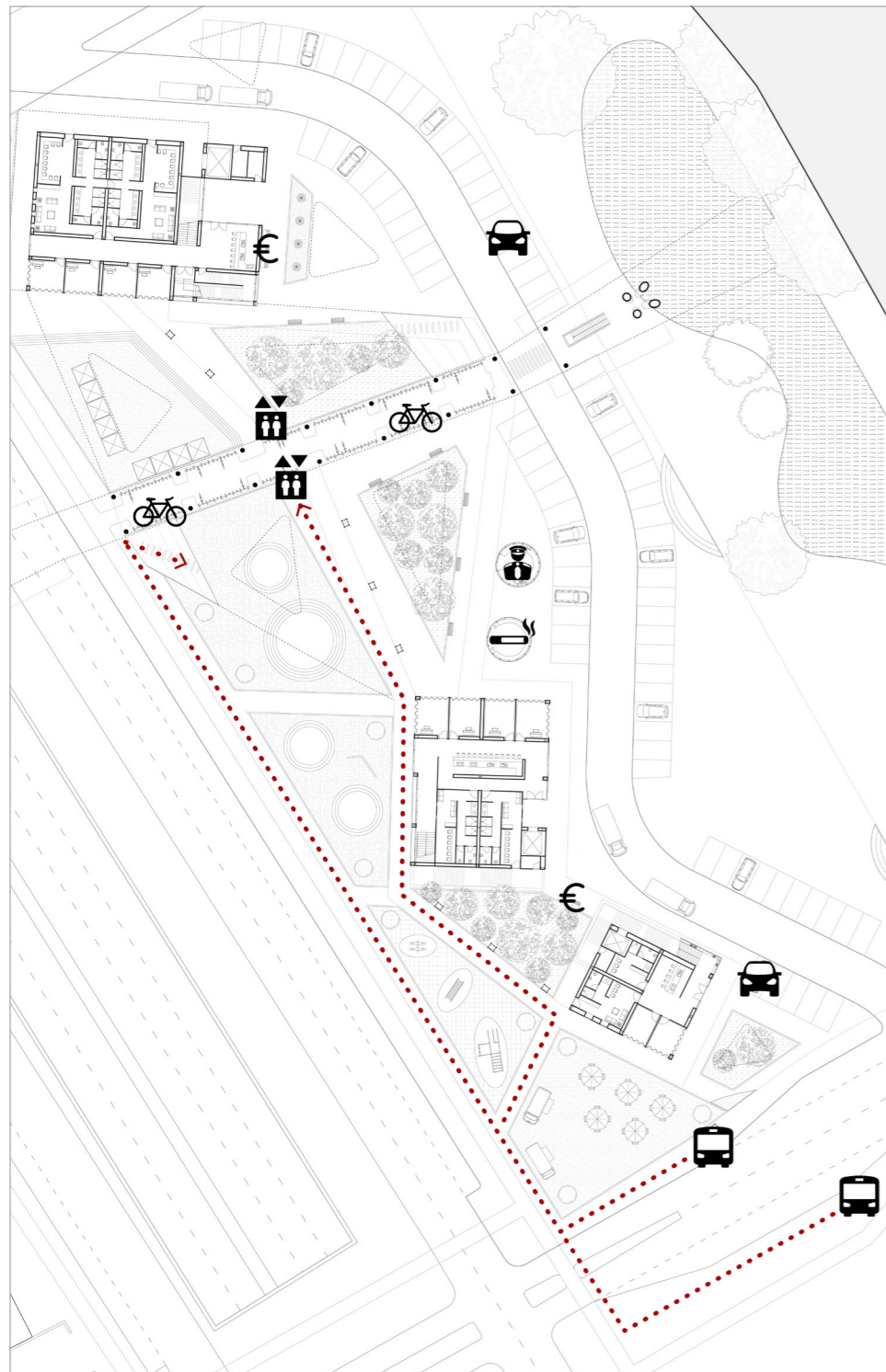

Arrival By Bike

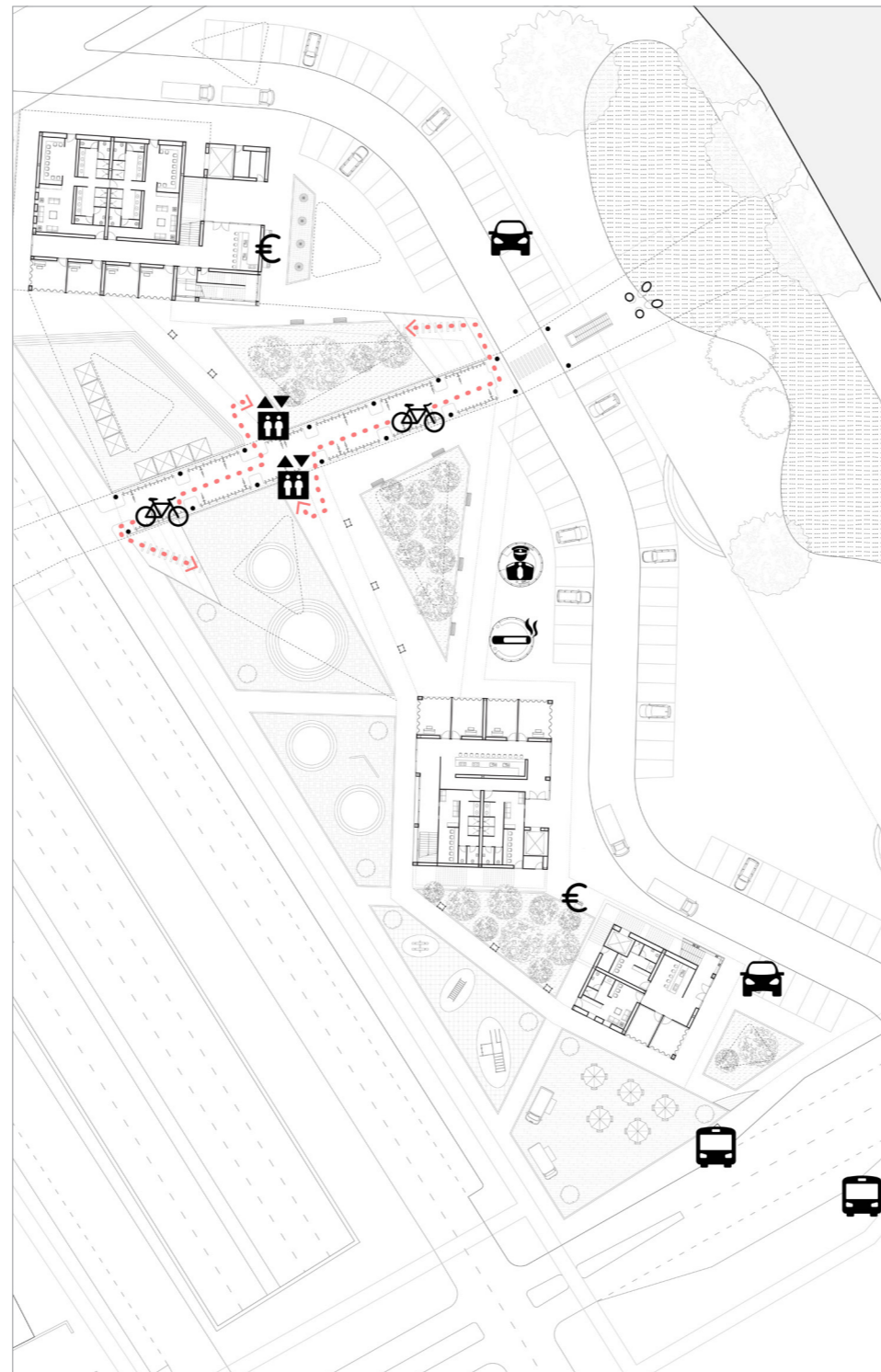

Arrival By Car

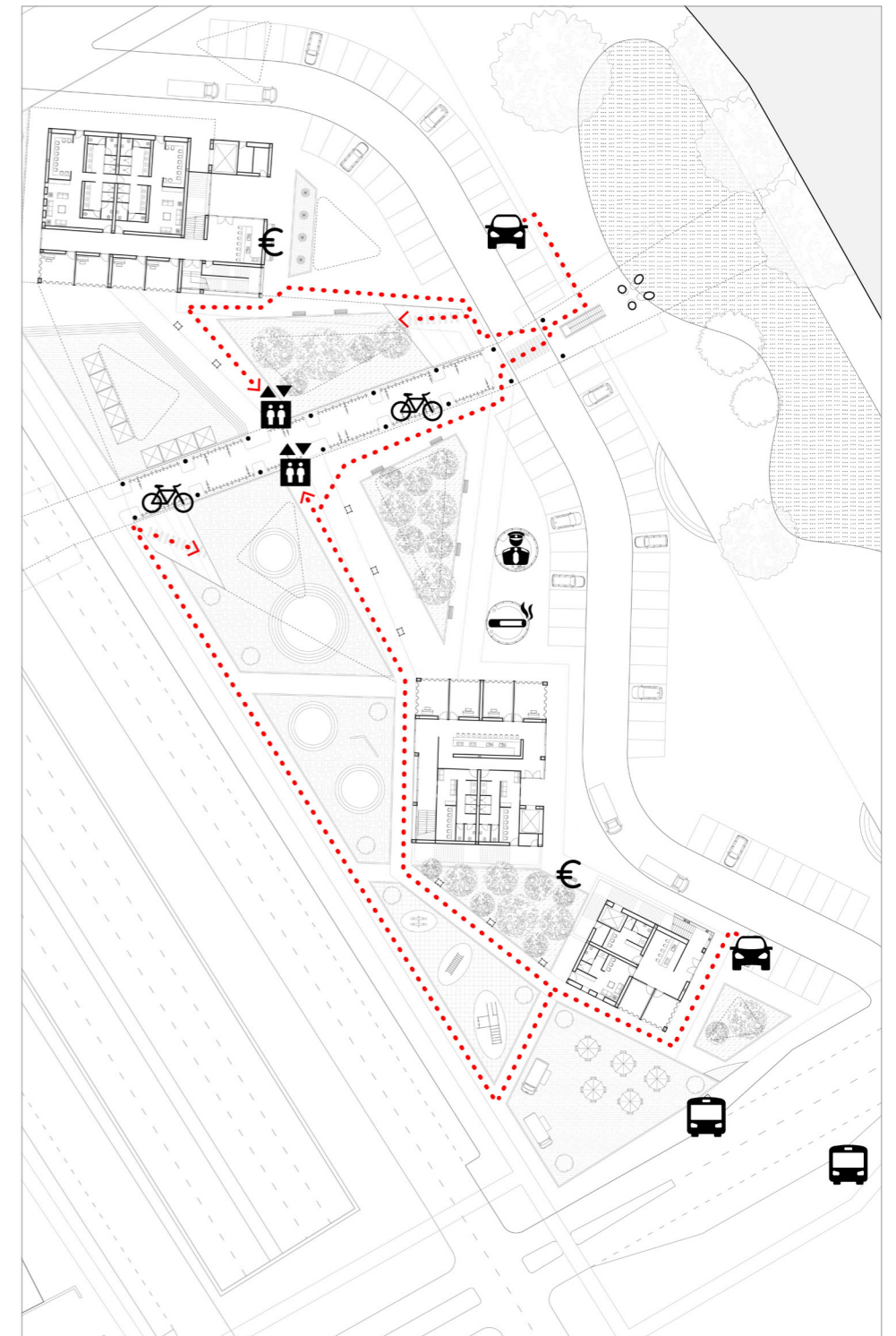





STRUCTURE

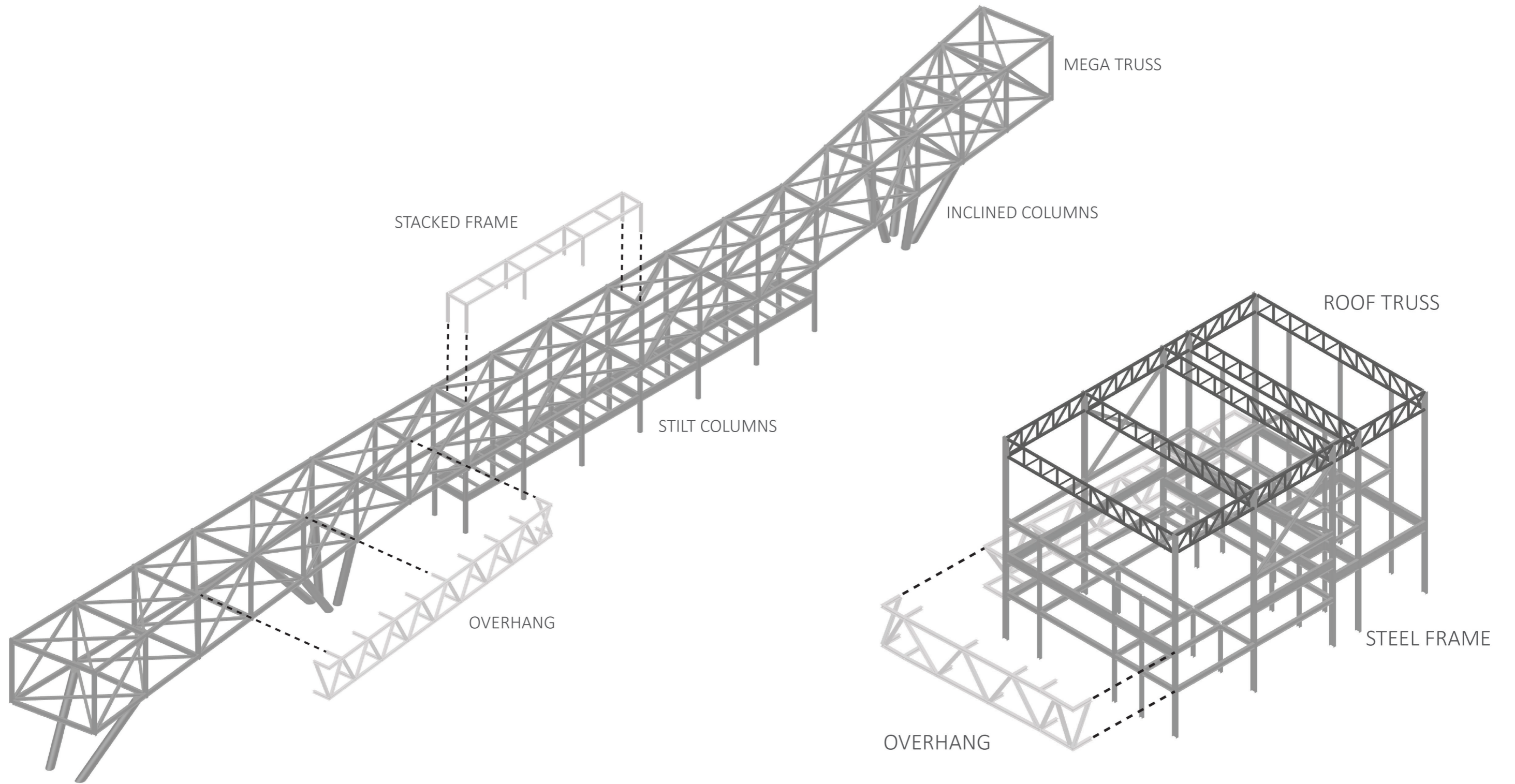

STRUCTURE

STEEL FRAME END

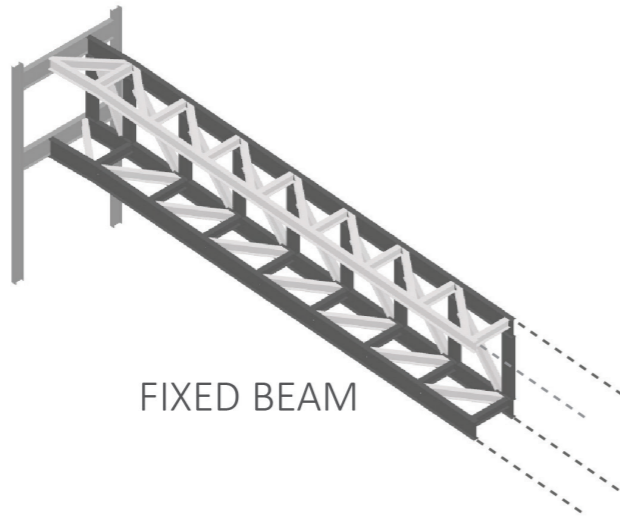

FIXED BEAM

TRUSS COLUMN

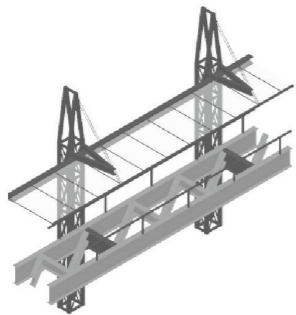

CONTINUOUS BEAM

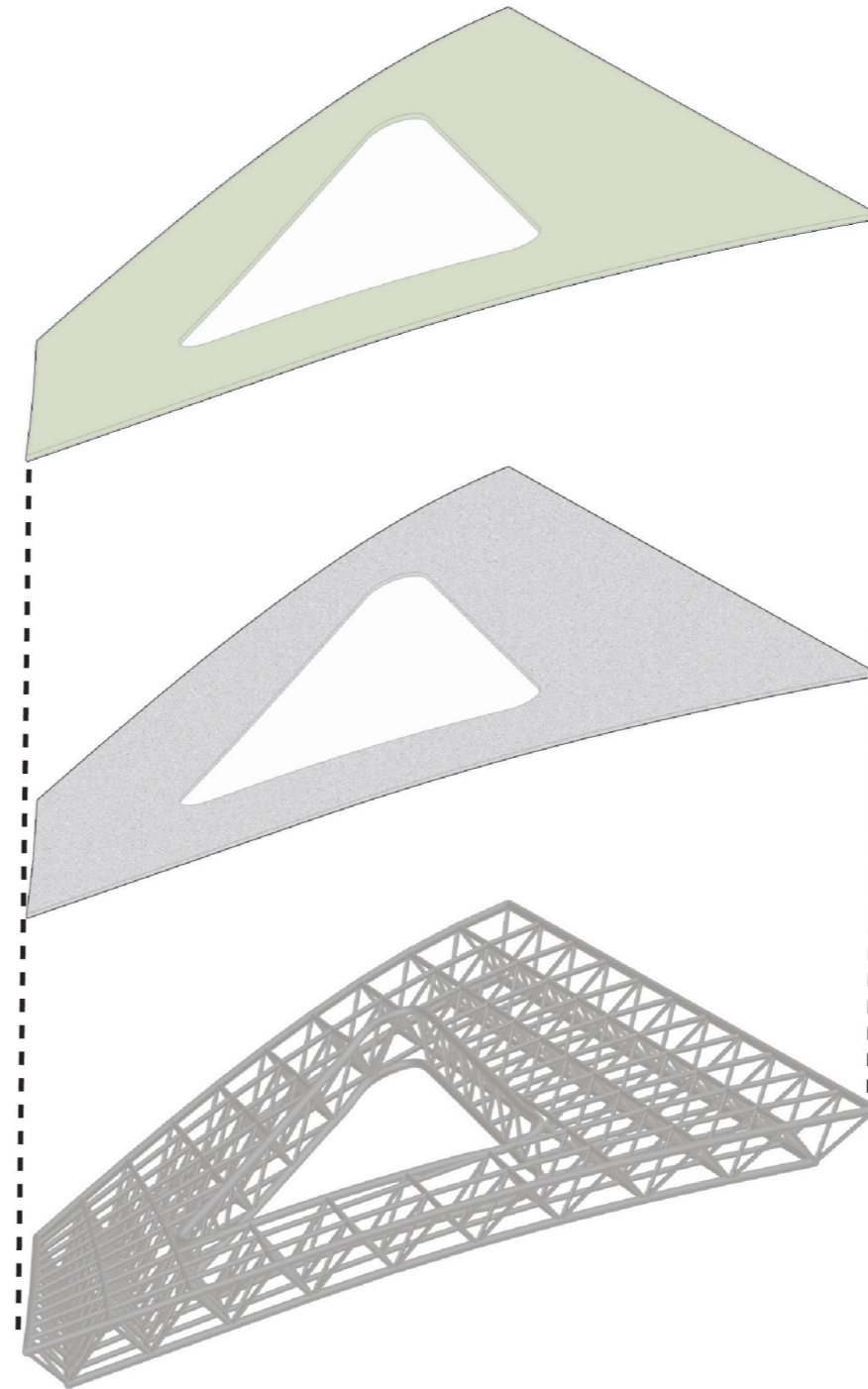

EXTENSIVE GREEN ROOF

LIGHT WEIGHT CONCRETE

3D TRUSS

FACADE CONCEPT

ENERGIES AT PLAY: HEAT X SOUND

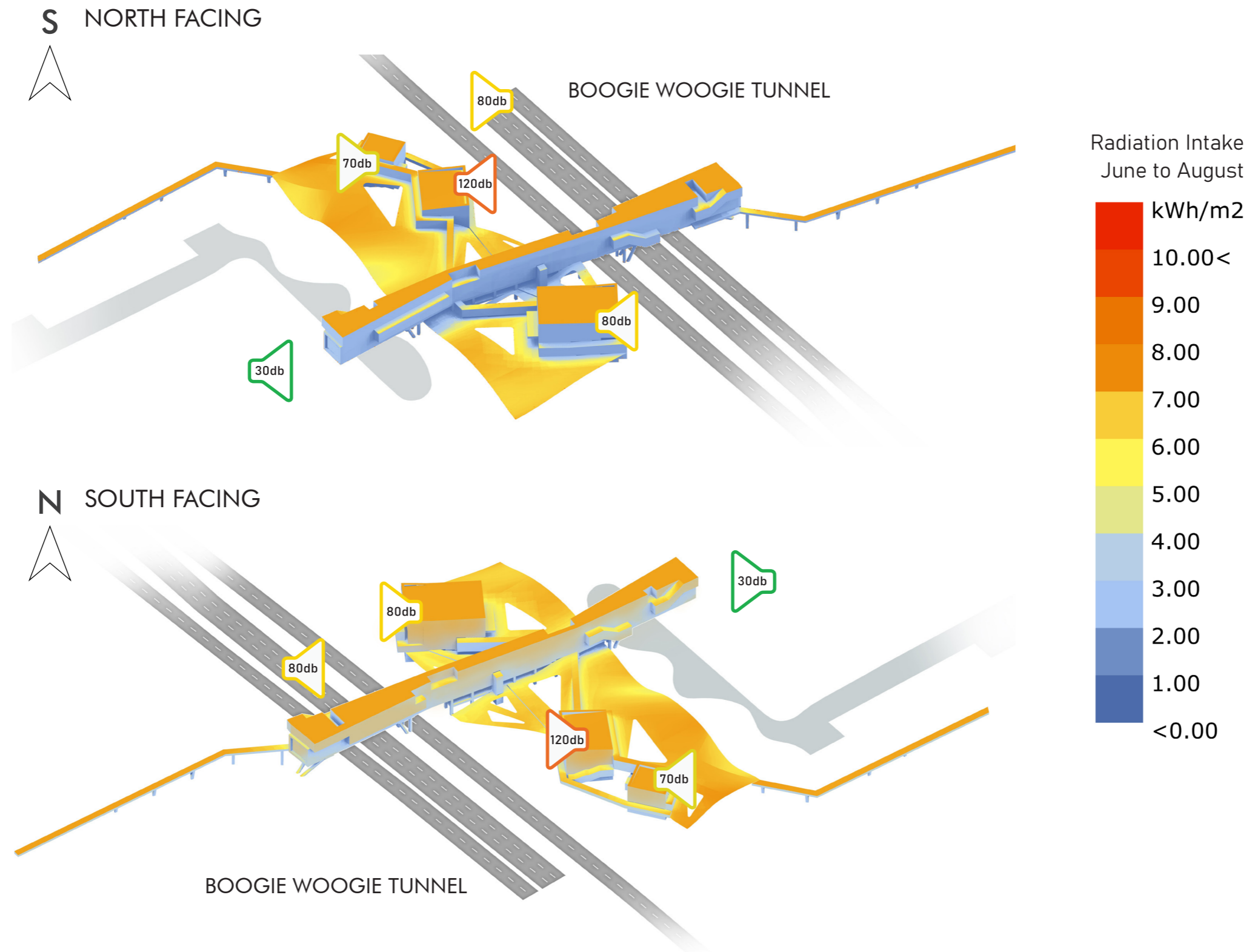

FACADE CONCEPT

THERMAL CONTROL X ACOUSTICS STRATEGY

METAL TUBE



SOUND BARRIER



SOLAR HEAT PIPE

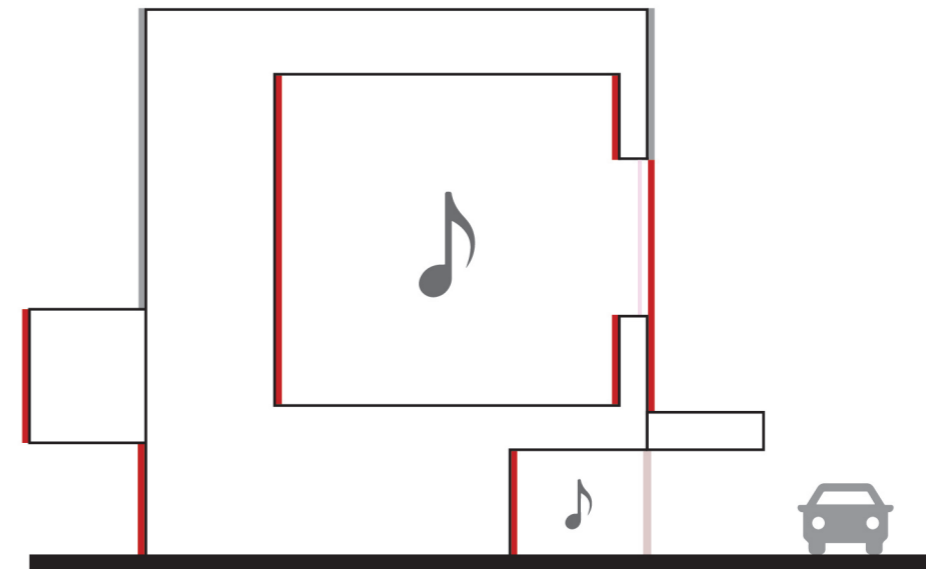
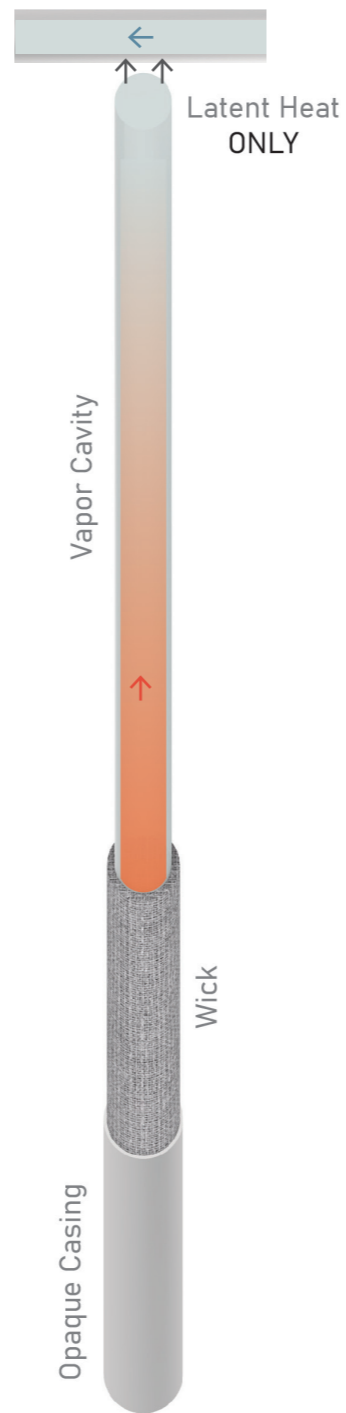

- Sound Barrier
- Solar Heat Pipe
- Curved Glass
- Typical Glass

SUMMER - COOLING MECHANISM

Concert Halls



Public Corridor

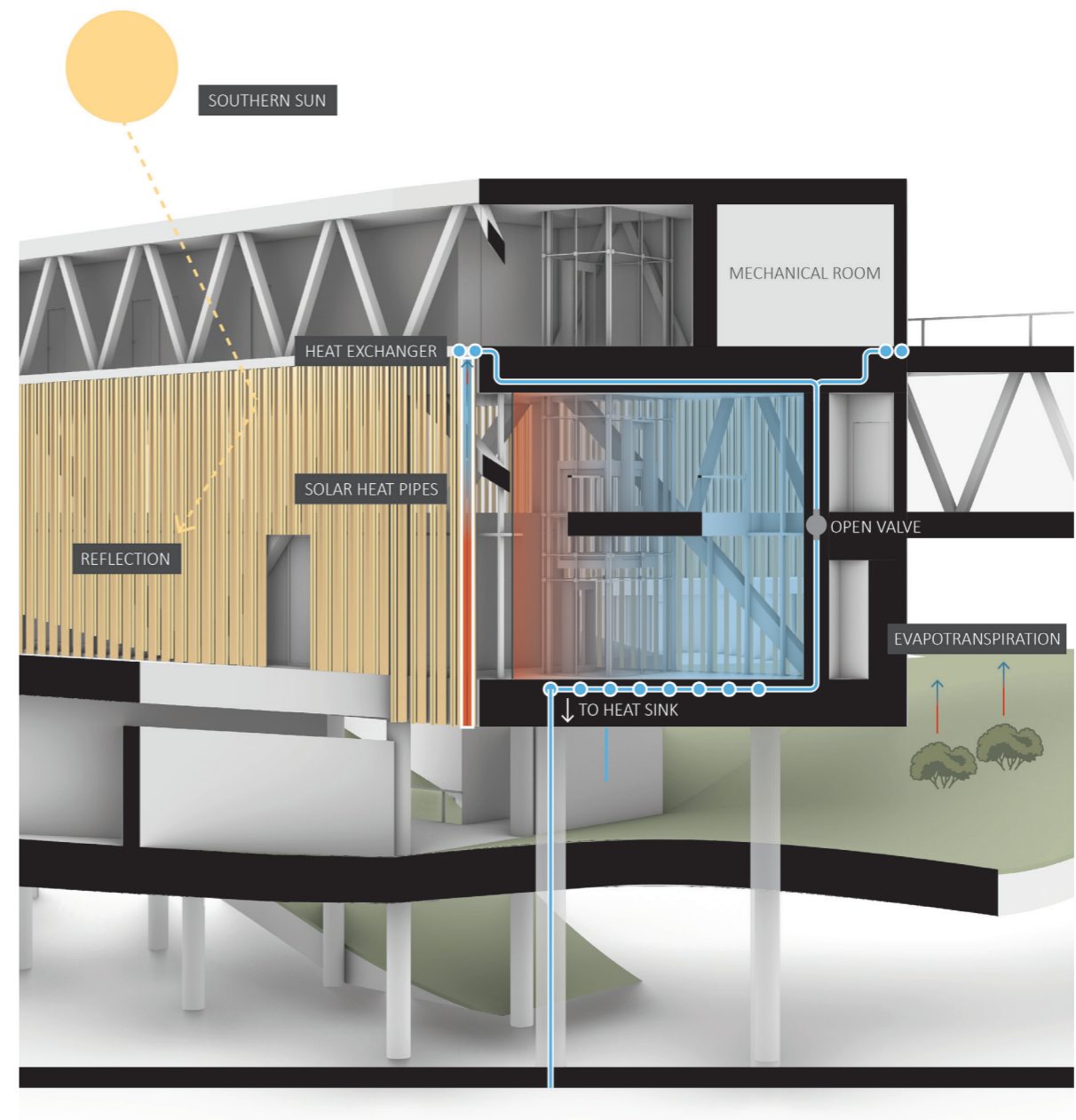

SUMMER - COOLING MECHANISM

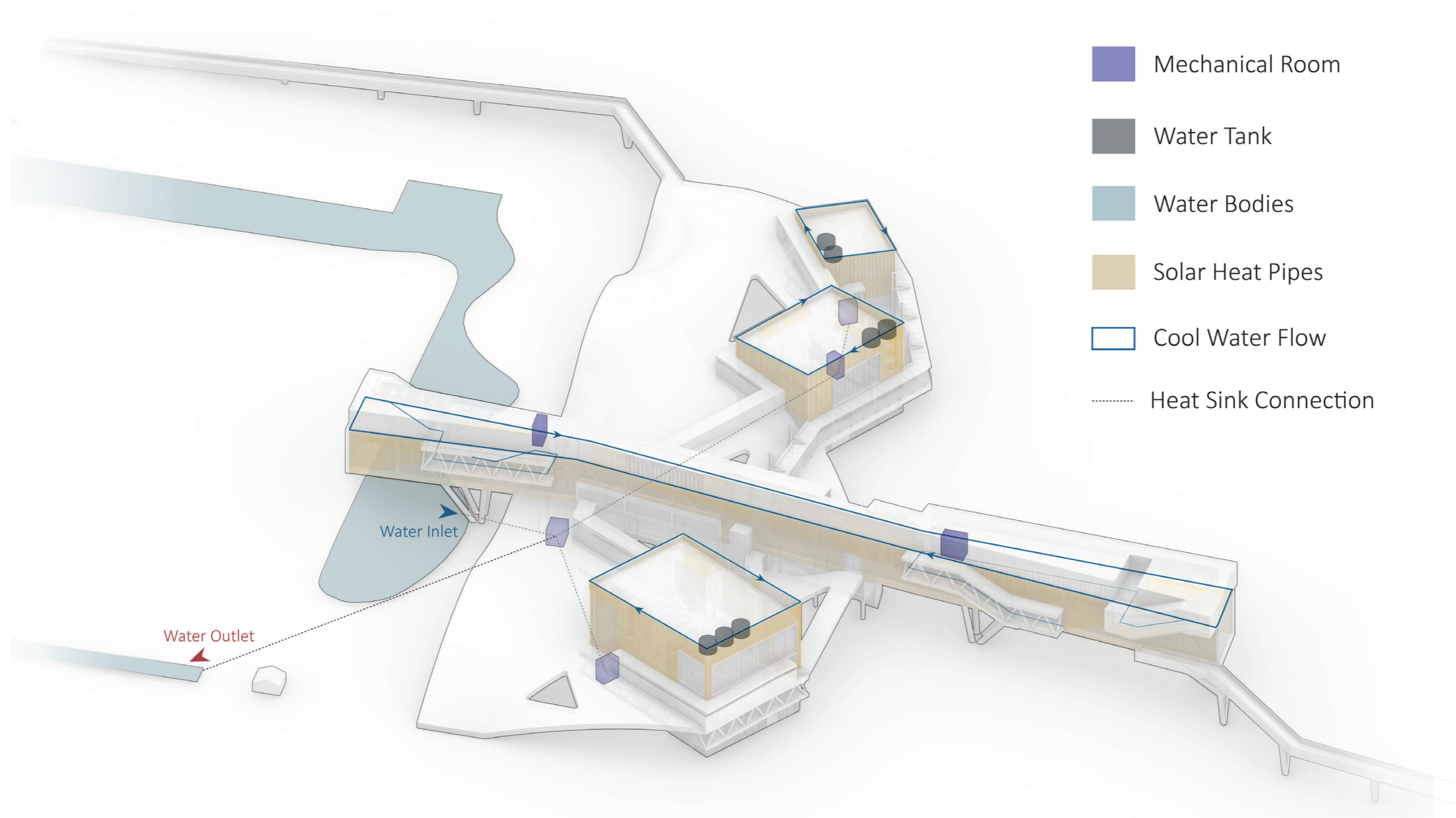

WINTER - HEATING MECHANISM

Concert Halls

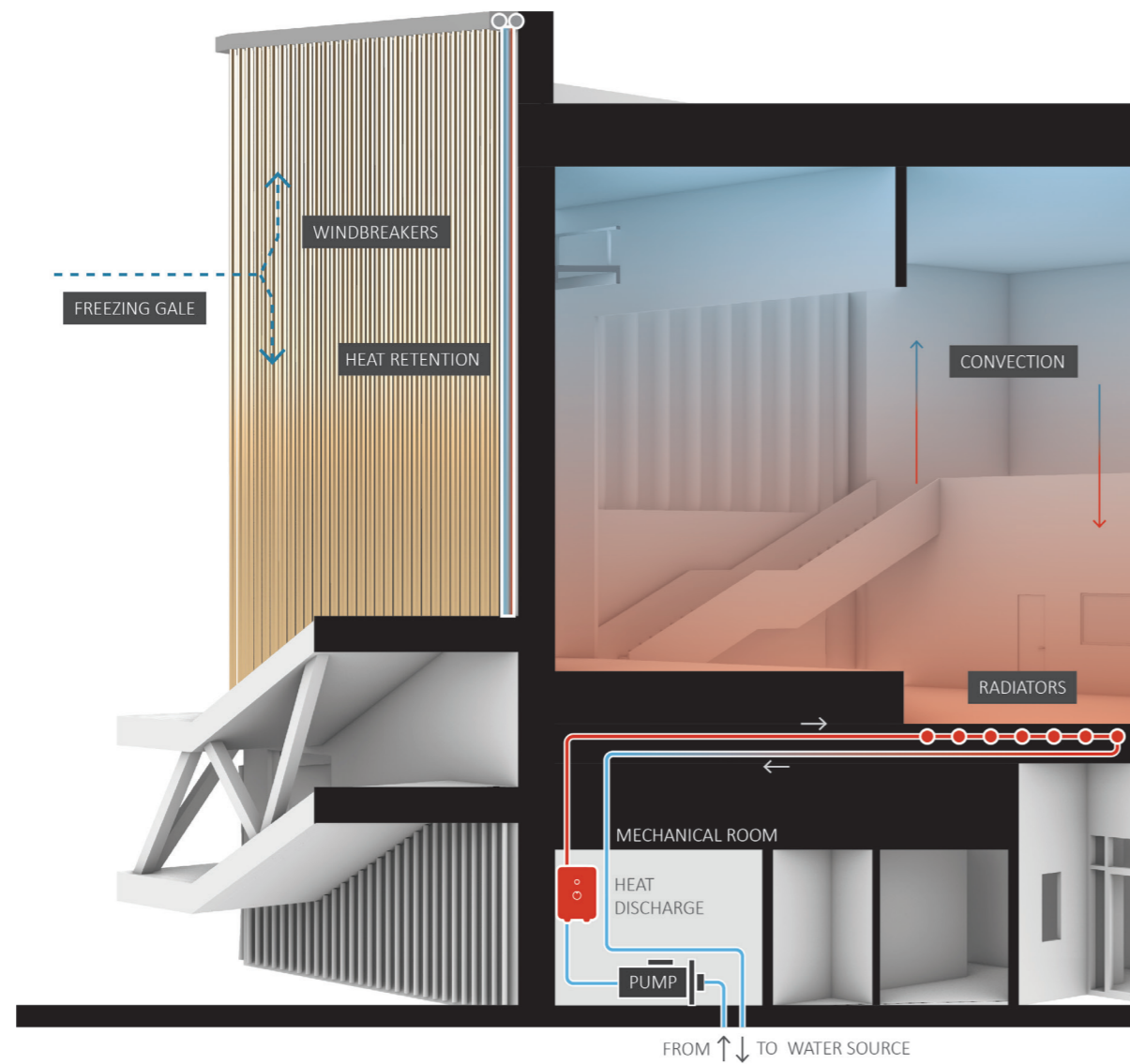

Public Corridor

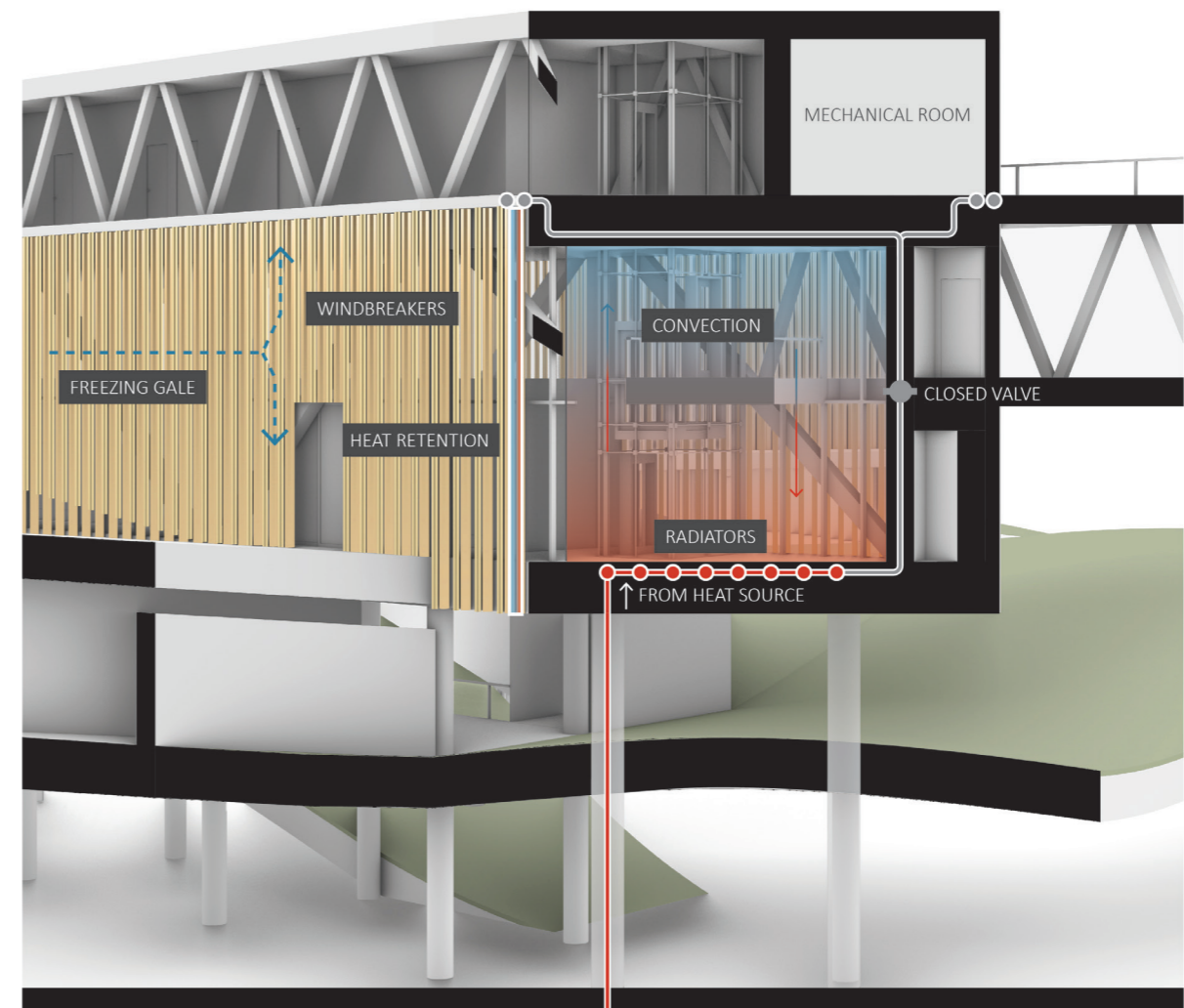

WINTER - HEATING MECHANISM

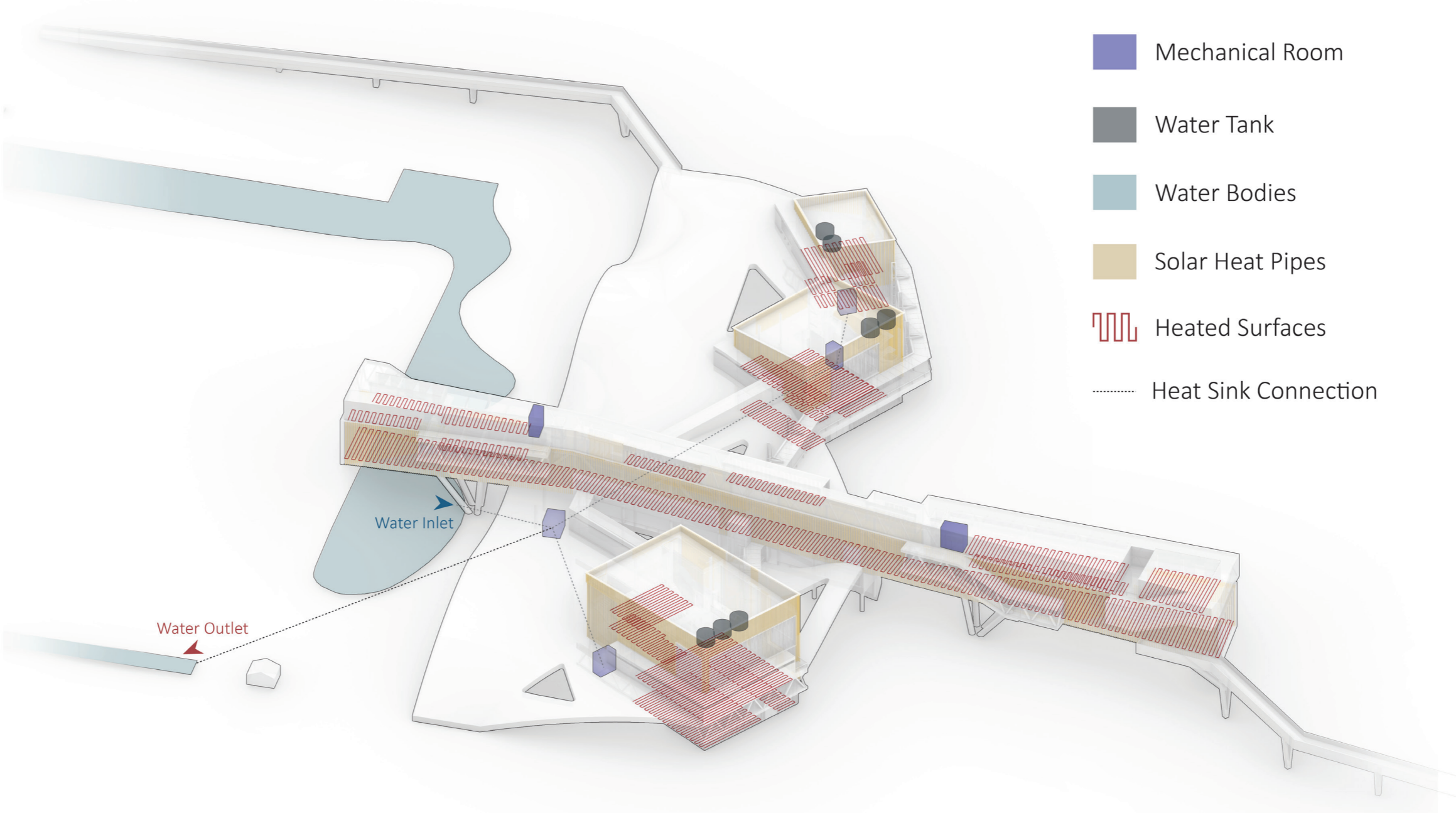

FACADE CONCEPT

APPLICATION PRINCIPLES

VARIATION 1: SIZING

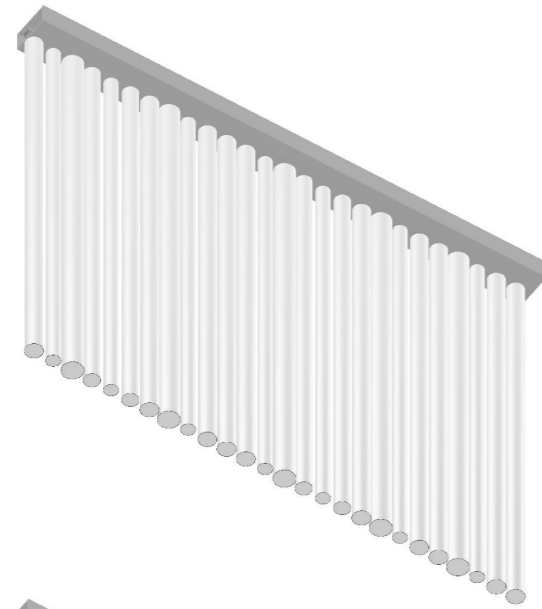

VARIATION 2: SPACING

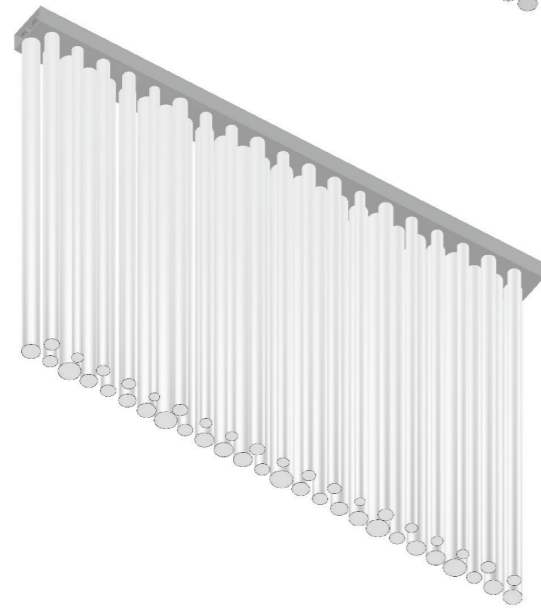

VARIATION 3: LAYERING

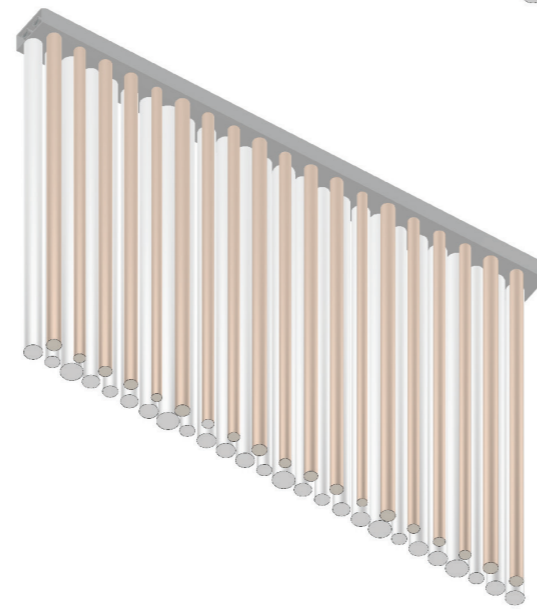

VARIATION 4: DYED COLOR

HEATED SURFACE

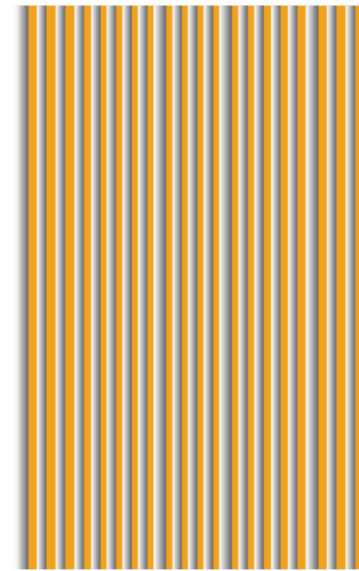

COOL SURFACE

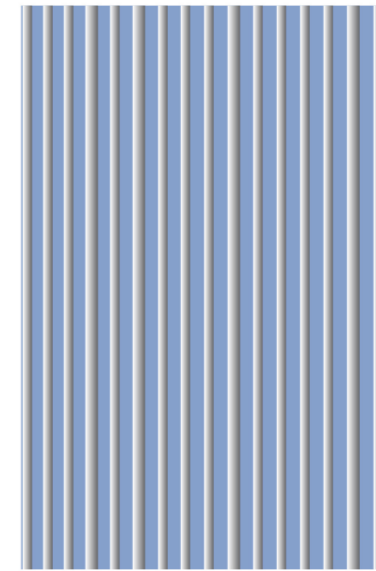

BARE WALL TREATMENT

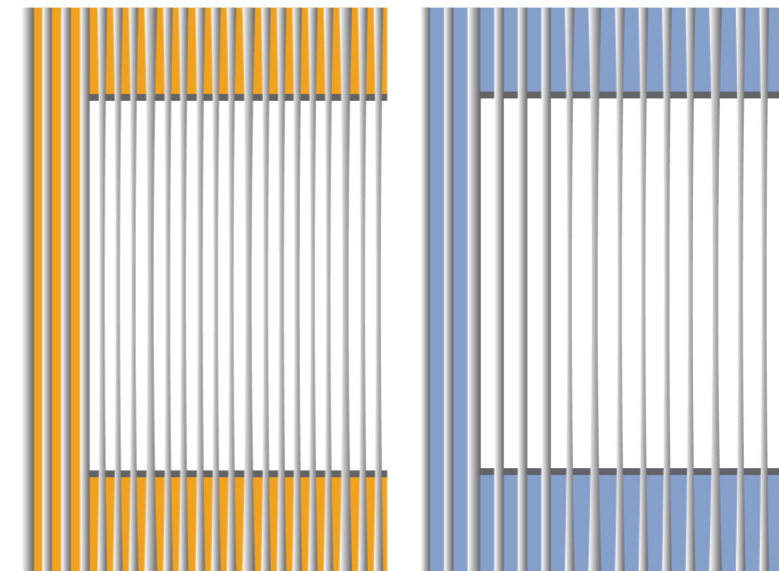

FENESTRATION TREATMENT

FACADE TYPES

Red Pipes + Red Aluminum Panel

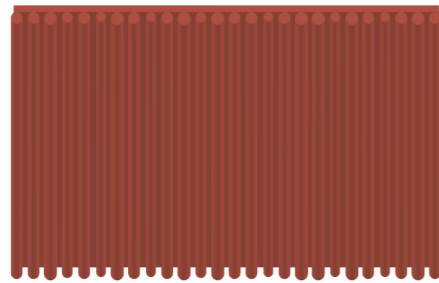

Silver Pipes + Red Aluminum Panel

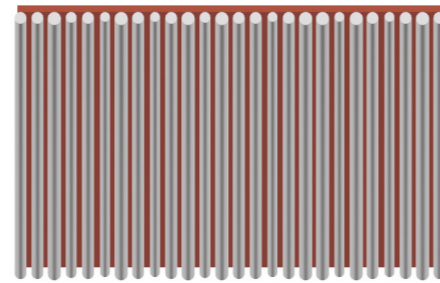

Brass Pipes + Silver Pipes + Glass Curtain

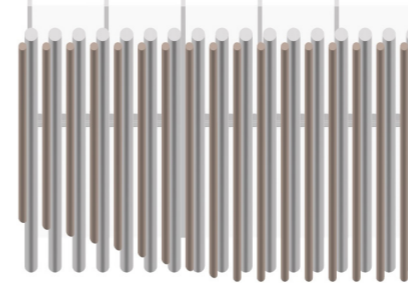

Cross Laminted Timber

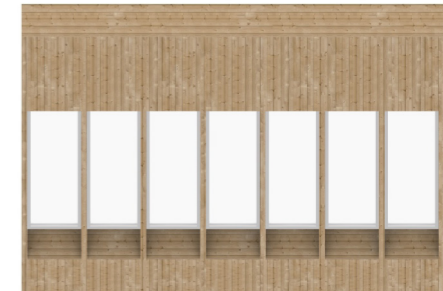

Purple Pipes + Purple Aluminum Panel

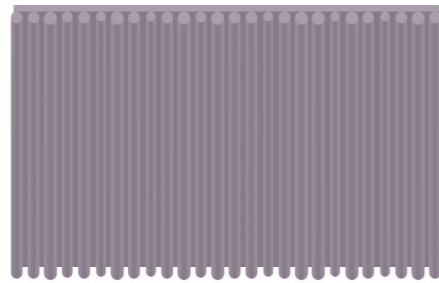

Silver Pipes + Purple Aluminum Panel

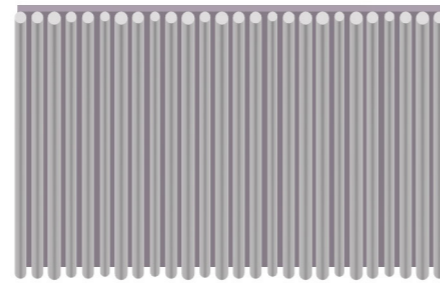

White Pipes + White Aluminum Panel

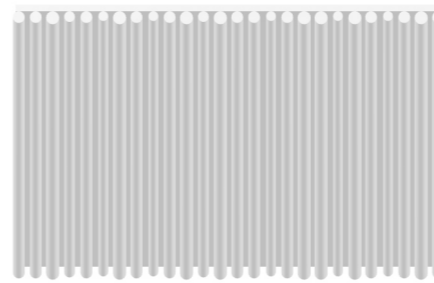

Polycarbonate Panel

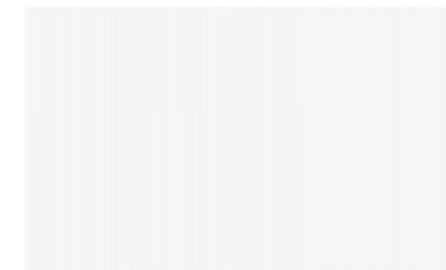

Blue Pipes + Blue Aluminum Panel

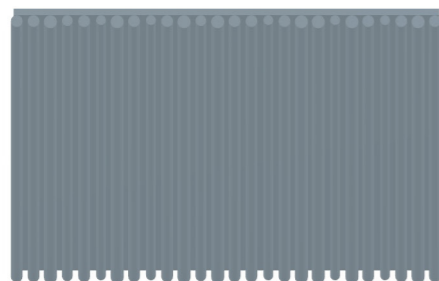

Silver Pipes + Blue Aluminum Panel

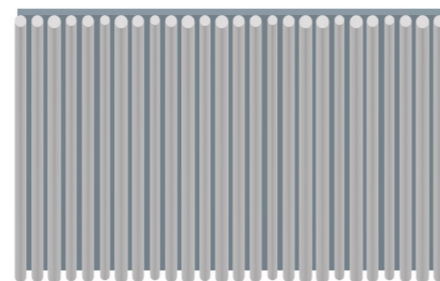

Dark Aluminum Panel

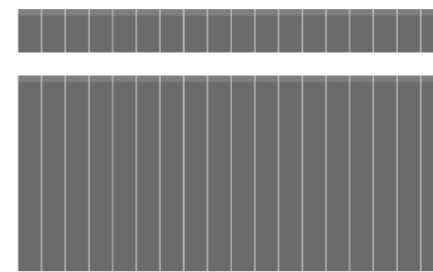

Corrugated Glass



FACADE OVERVIEW

PUBLIC CORRIDOR

Northern Facade

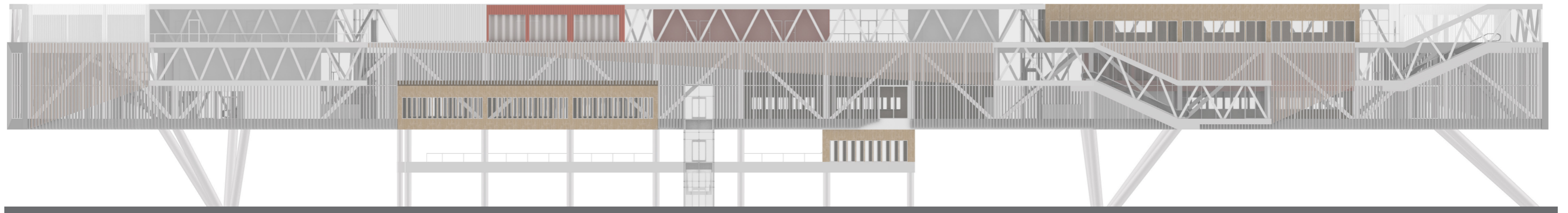

Southern Facade

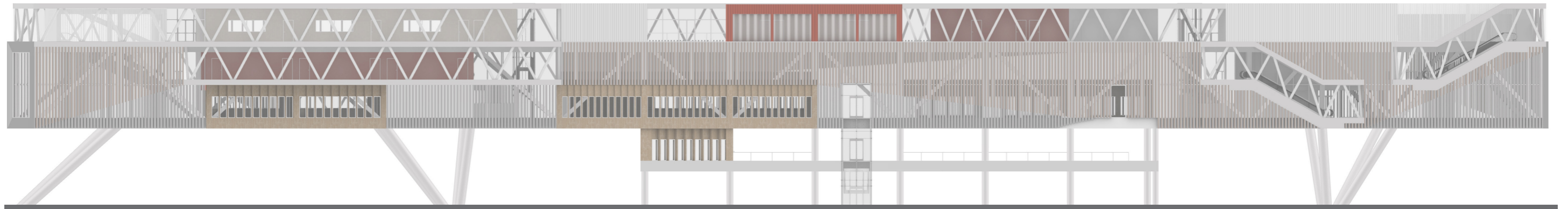

FACADE OVERVIEW

CONCERT HALLS

Classical Auditorium

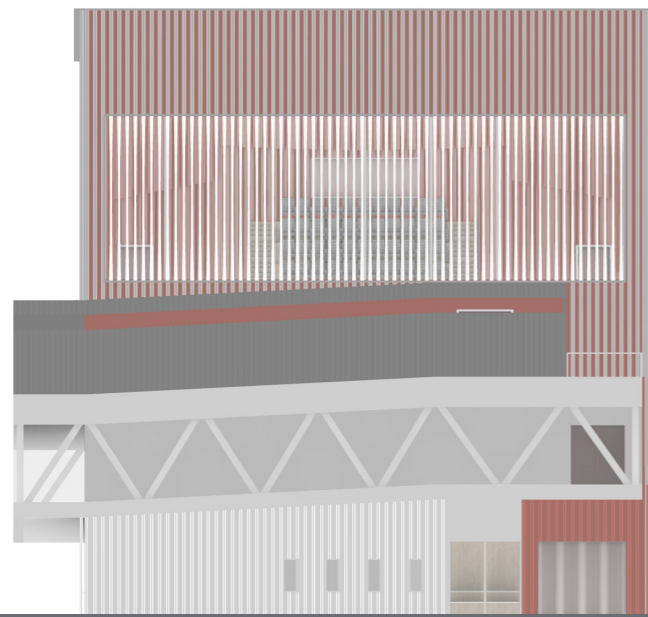

Rock & Pop Hall



Jazz Club

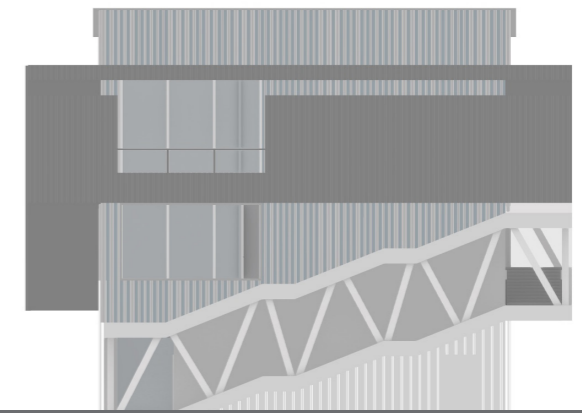

Front

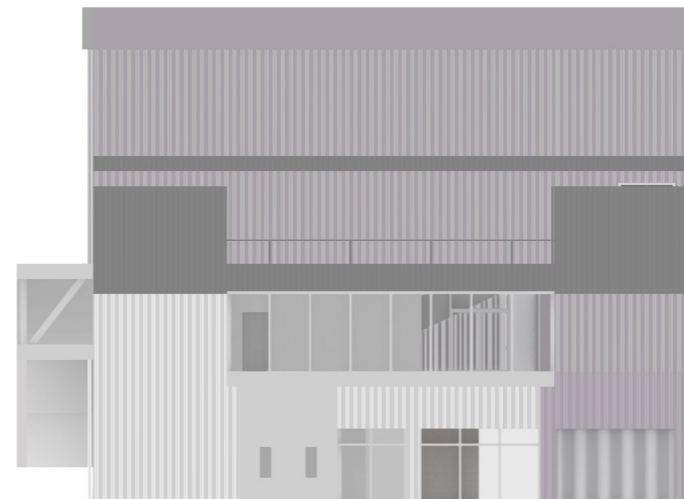
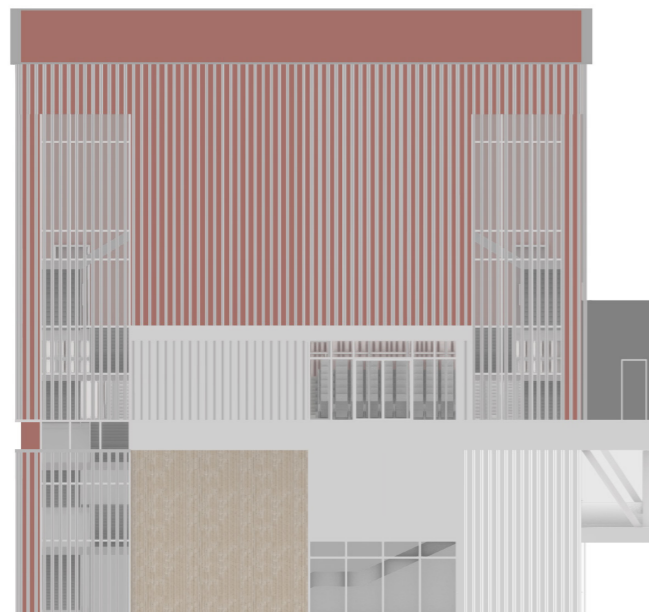

Back

FACADE DETAIL

CONCERT HALLS

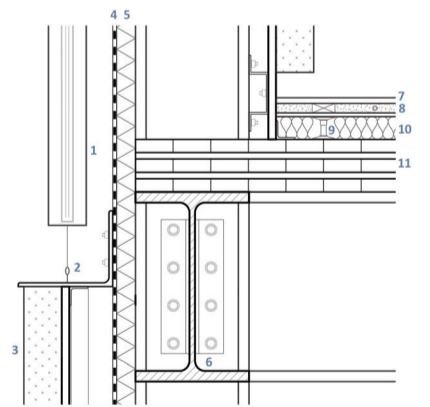
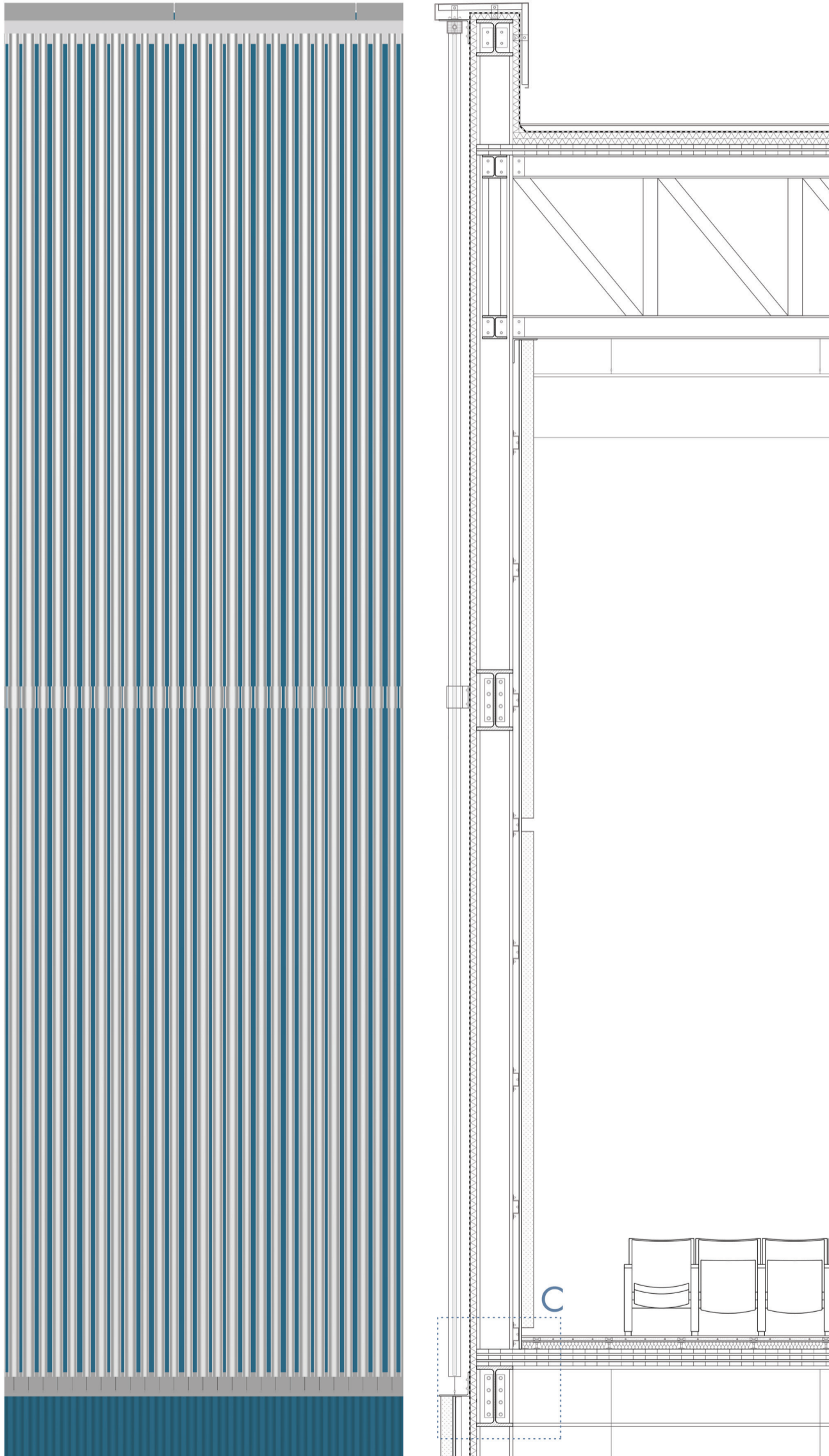

DETAIL C

- 1 Single Layer Solar Heat Pipe
- 2 Guided Cable
- 3 Anodized Steel Noise Barrier
- 4 Waterproof Membrane
- 5 Rigid Insulation
- 6 HEB 500 Steel Beam
- 7 15 mm Hardwood Flooring
- 8 Underfloor Heating Pipes
- 9 Adjustable Pedestal
- 10 Mineral Wool Insulation
- 11 139 V Cross Laminated Timber Panel

FACADE DETAIL

Public Corridor

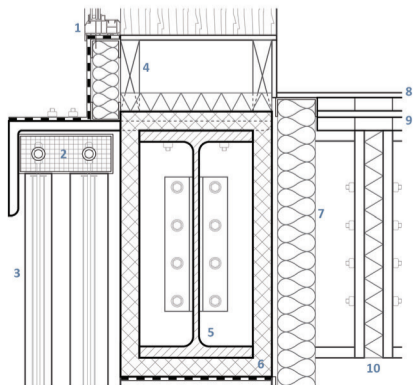
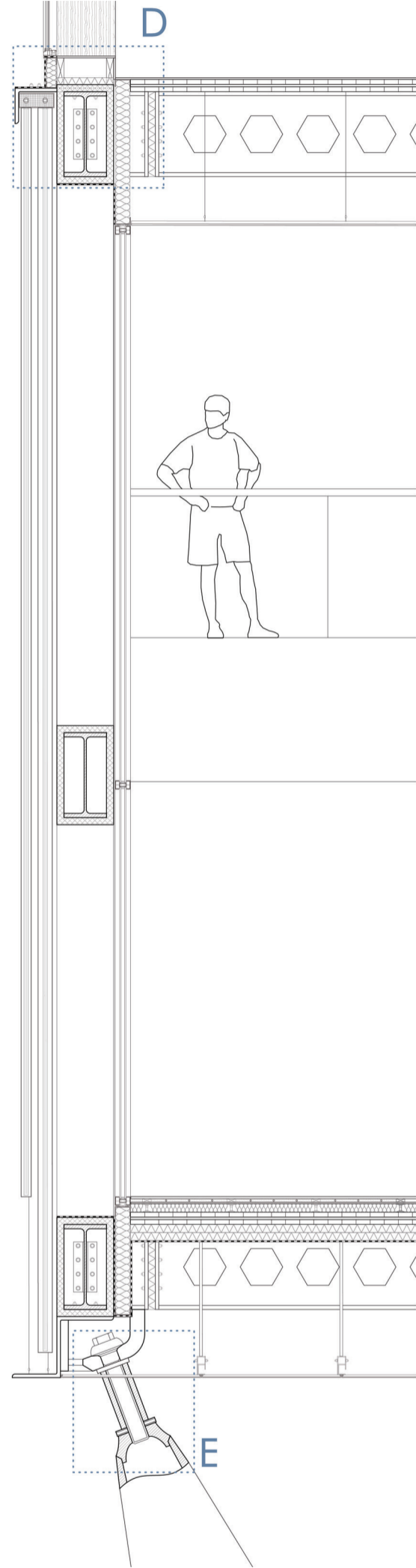
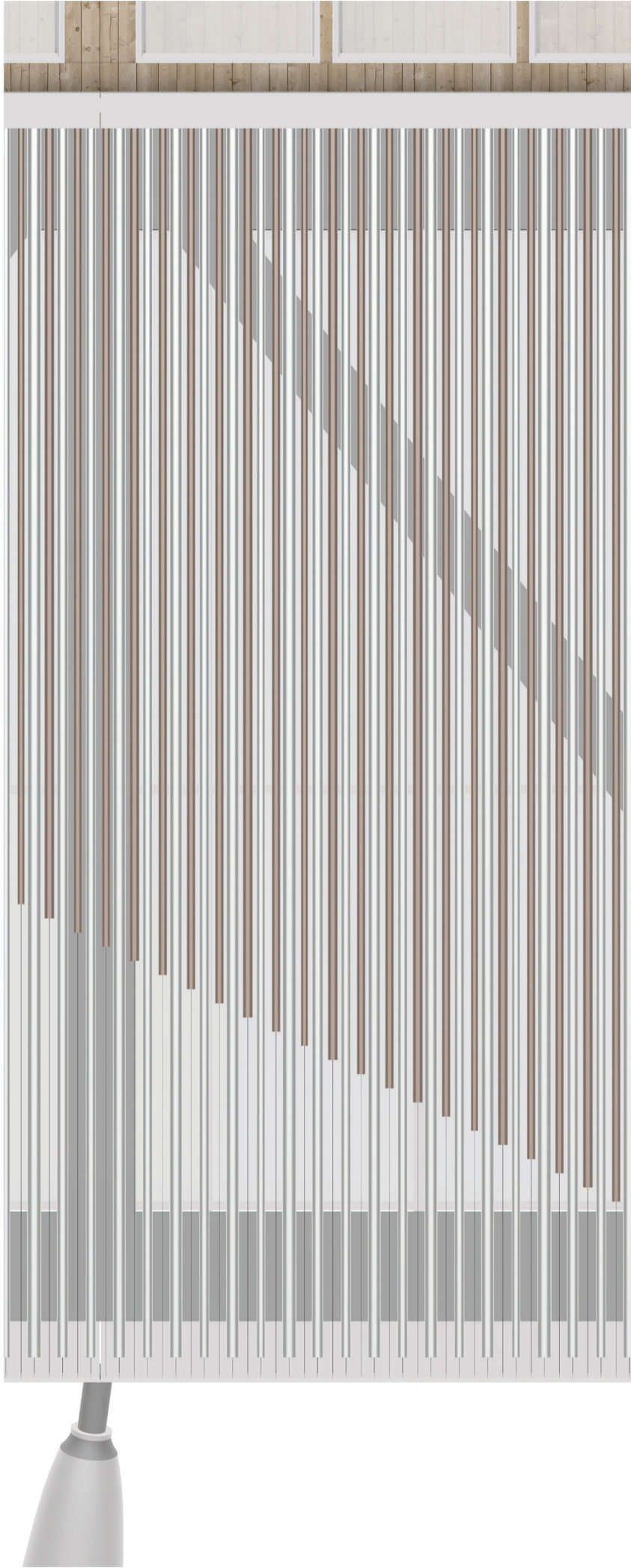

DETAIL D

- 1 Double Glazed Aluminium Window
- 2 Heat Exchanger
- 3 Double Layer Solar Heat Pipe
- 4 Internal Sill Lining Support Block
- 5 HEB 600 Steel Beam
- 6 Fire Protection
- 7 HEB 260 Steel Beam
- 8 Cement Screed Floor Finish
- 9 87 V Cross Laminated Timber Panel
- 10 Structural Thermal Break

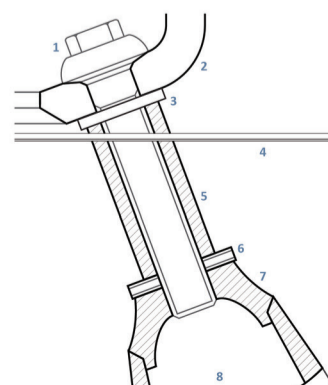

DETAIL E

- 1 Bolt Fixing
- 2 Node
- 3 Plastic Separation Washer
- 4 Aluminium Suspended Ceiling
- 5 Sleeve
- 6 Bolt Stopper
- 7 End Cone
- 8 Stainless Steel Pipe

FACADE DETAIL

MUSIC SCHOOL WALKWAY

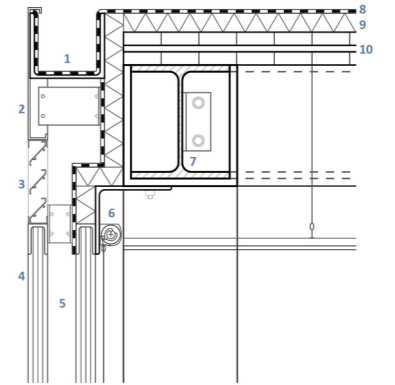
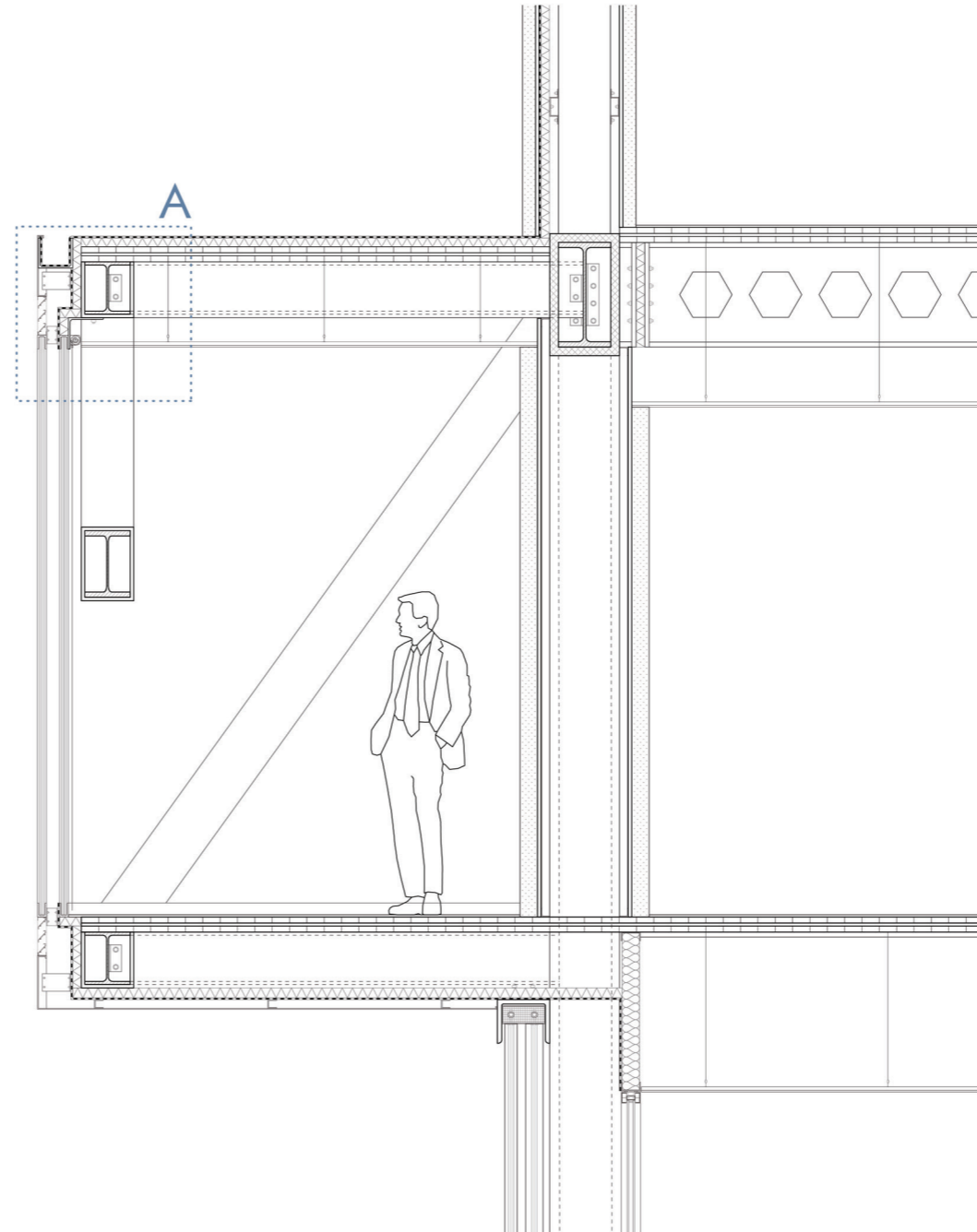

DETAIL A

- 1 Formed Gutter
- 2 6 mm Aluminium Capping
- 3 Air Vent
- 4 10 mm Low Iron Laminated Glass
- 5 75 mm Air Space
- 6 Roller-blind Sunshade
- 7 HEB 260 Steel Beam
- 8 Waterproof Membrane
- 9 Rigid Insulation
- 10 87 V Cross Laminated Timber Panel

FACADE DETAIL

ARTIFICIAL LANDSCAPE I PRELUDE

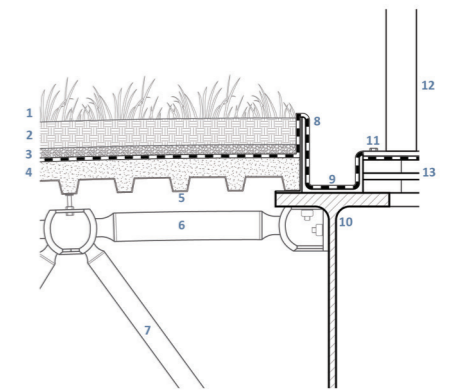
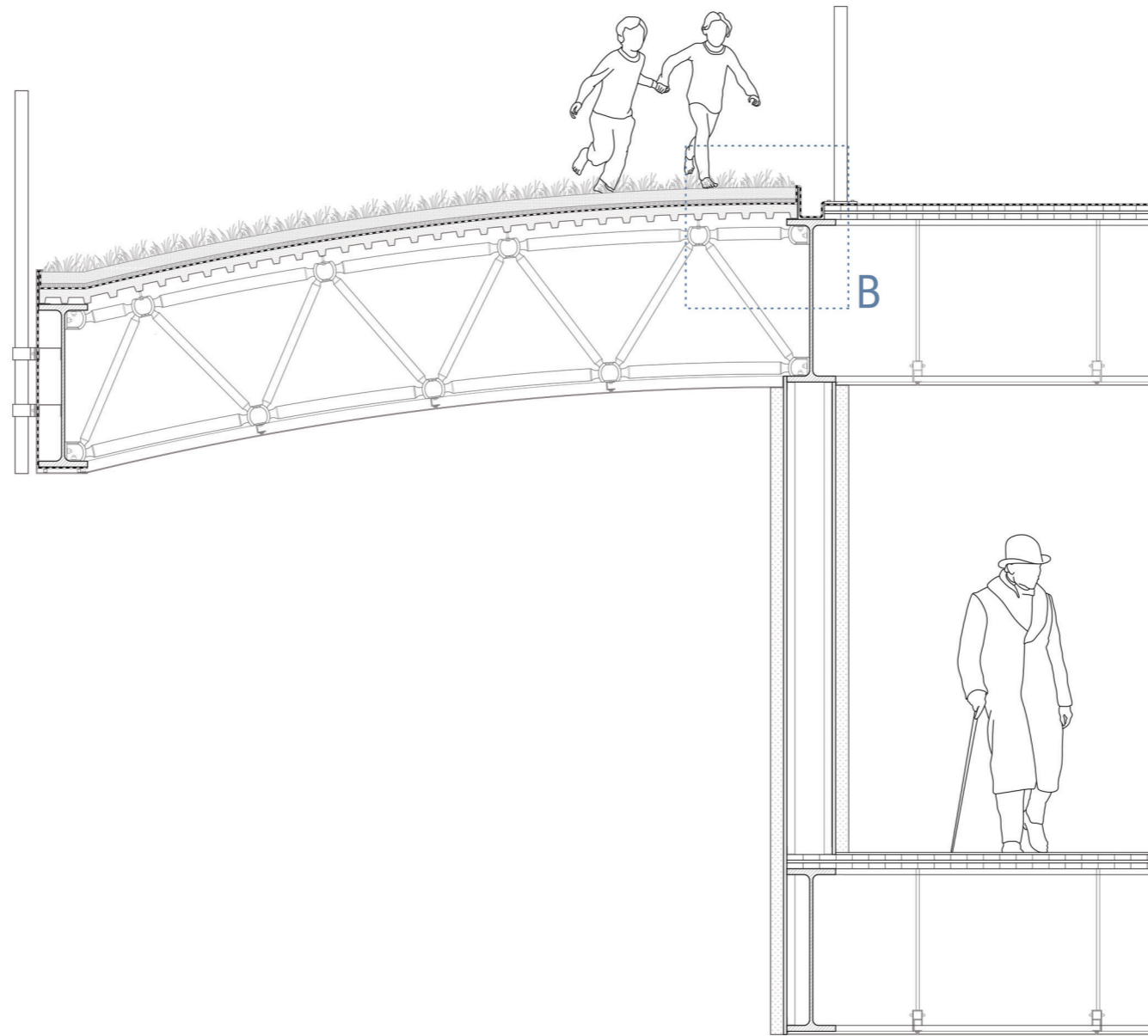
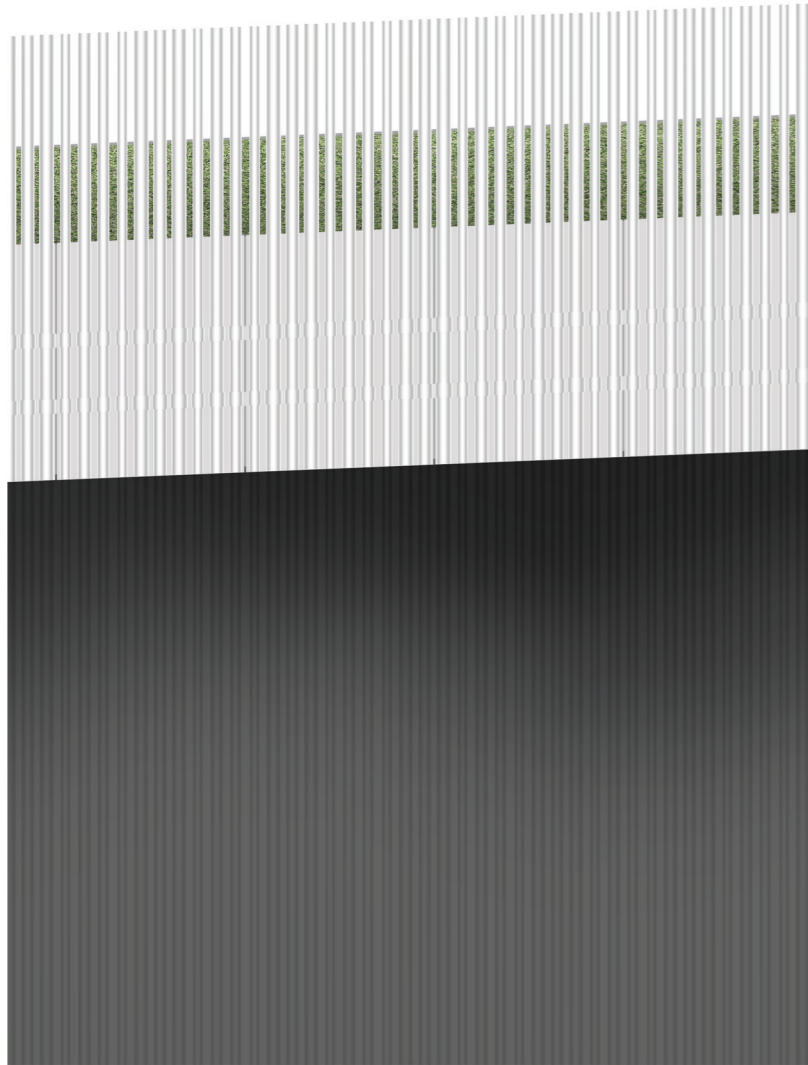

DETAIL B

- 1 Plant Cover
- 2 70 mm Growing Media
- 3 25 mm Drainage Filling
- 4 50 mm Lightweight Concrete
- 5 38 mm Steel Decking
- 6 Steel Chord Member
- 7 Steel Diagonal Member
- 8 Waterproof Membrane
- 9 Formed Gutter
- 10 HEB 1000 Steel Beam
- 11 10 mm Steel End Plate
- 12 Anodized Steel Balustrade
- 13 87 V Cross Laminated Timber Panel

CIRCULARITY - DURABILITY - ADAPTABILITY

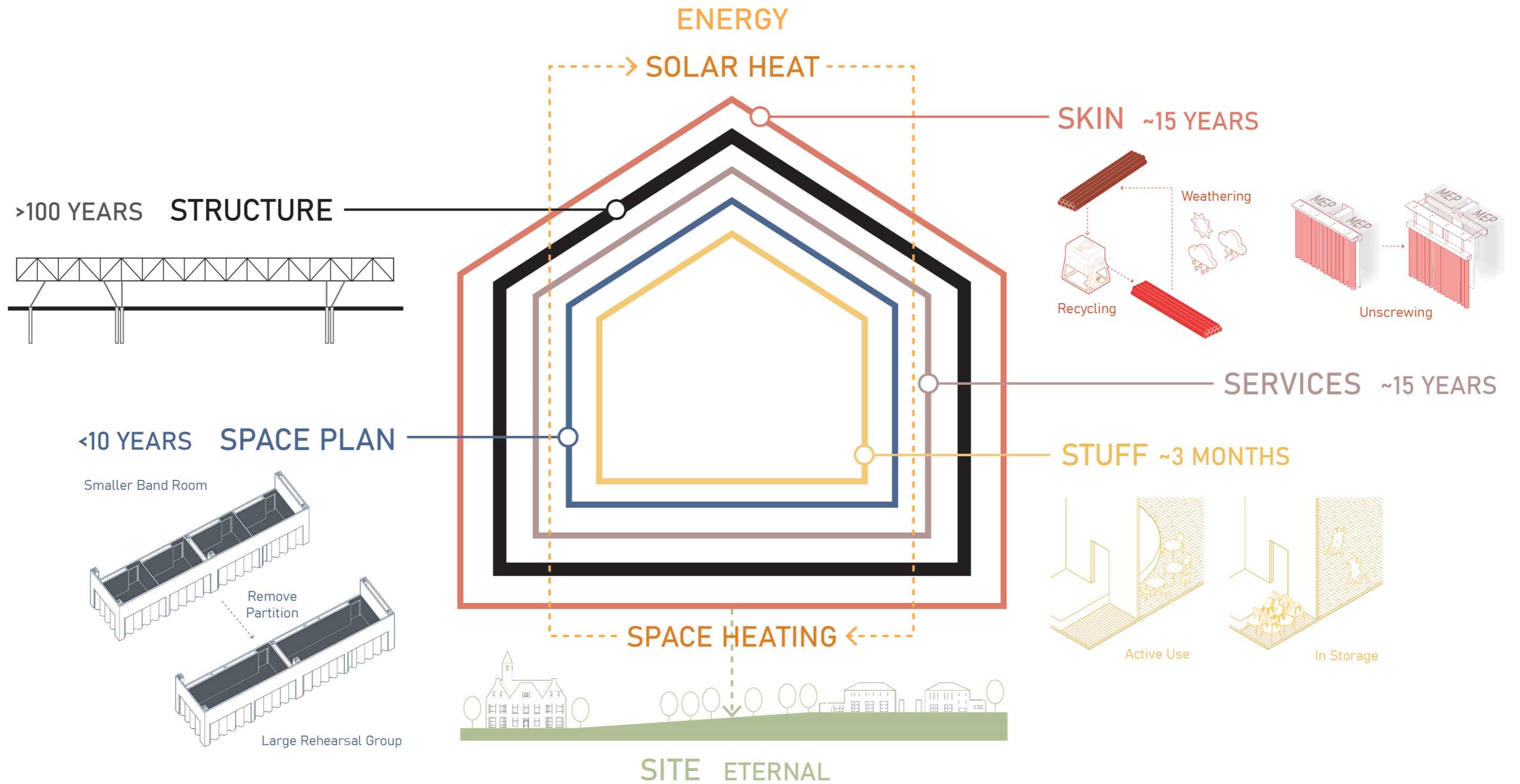

MULTIPLICITY



People

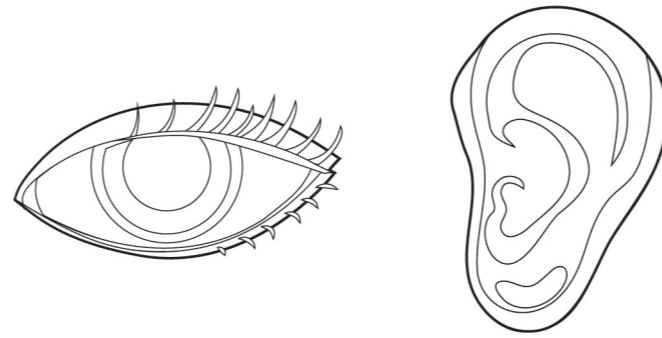

Modalities

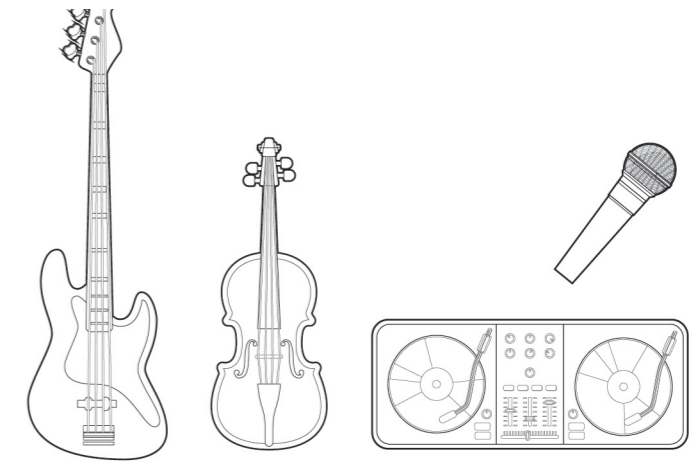

Genres

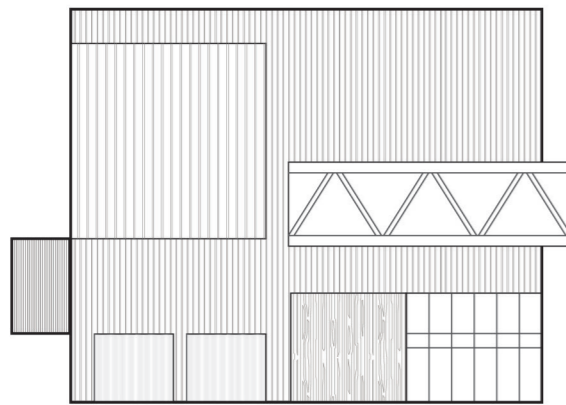

Materiality

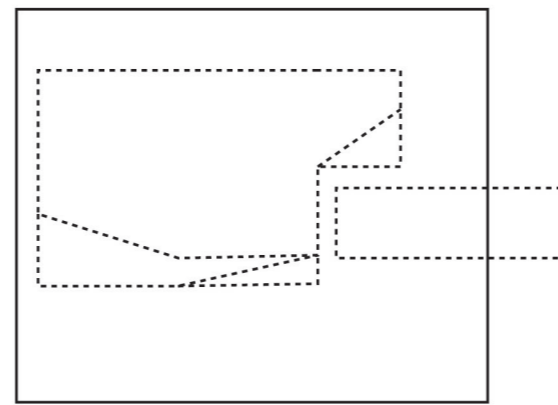

Use

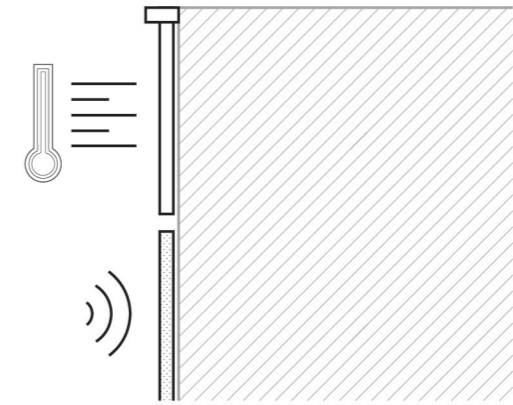

Building Technology

THE NEW MUSIC MARVEL FOR BINCKHORST / CID?

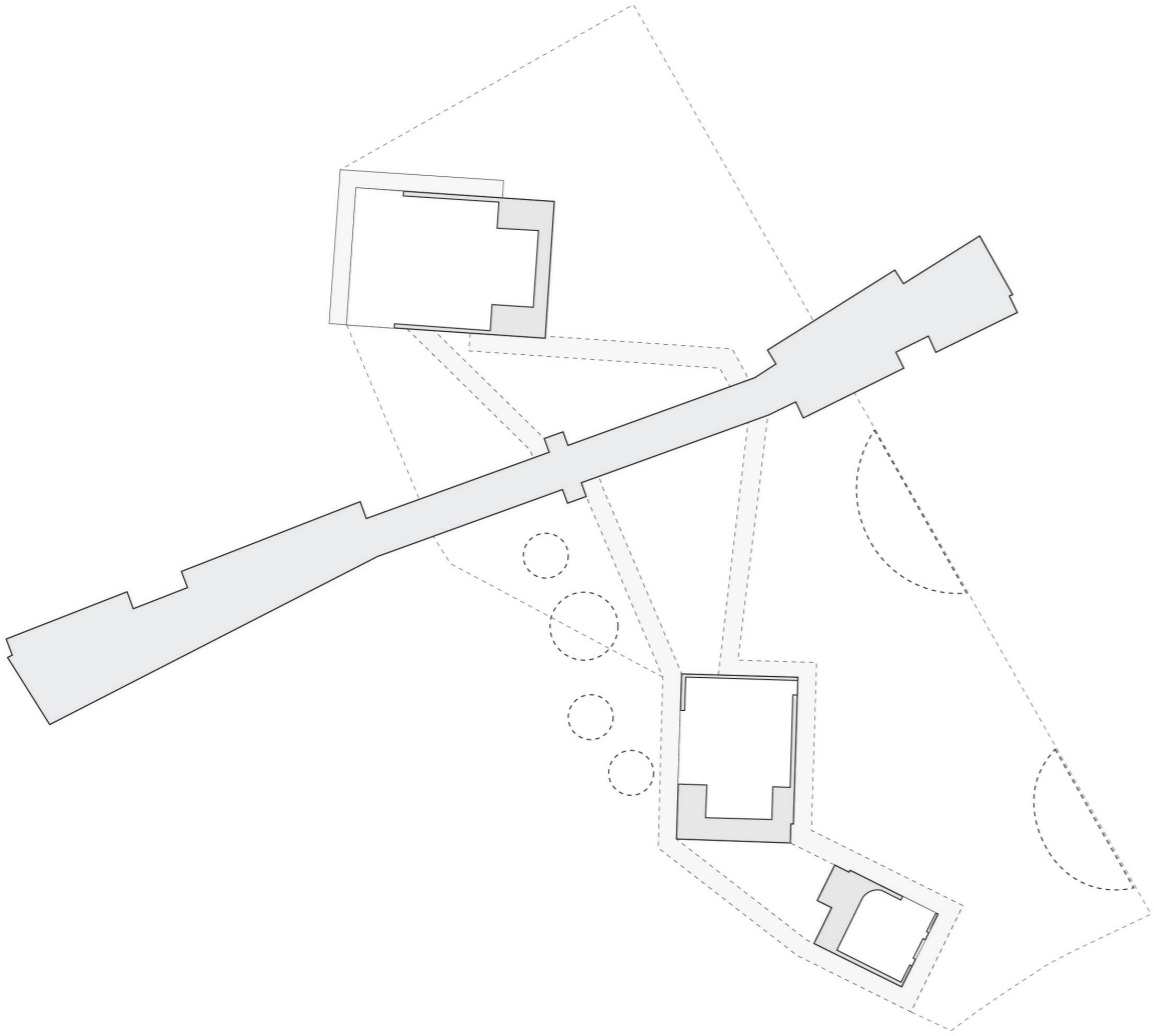

Binckcross

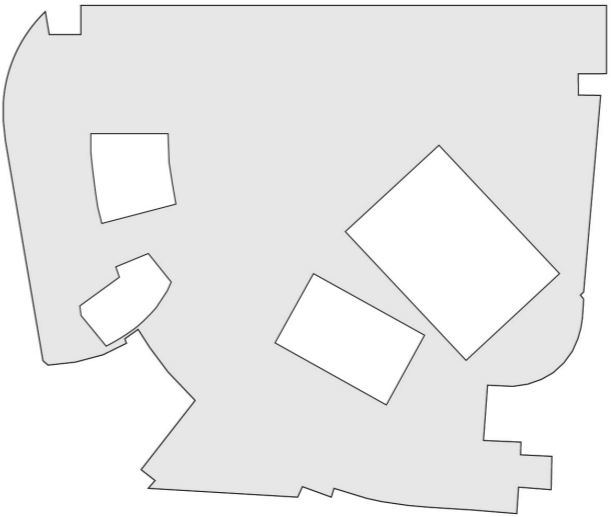

Theatre aan het Spui

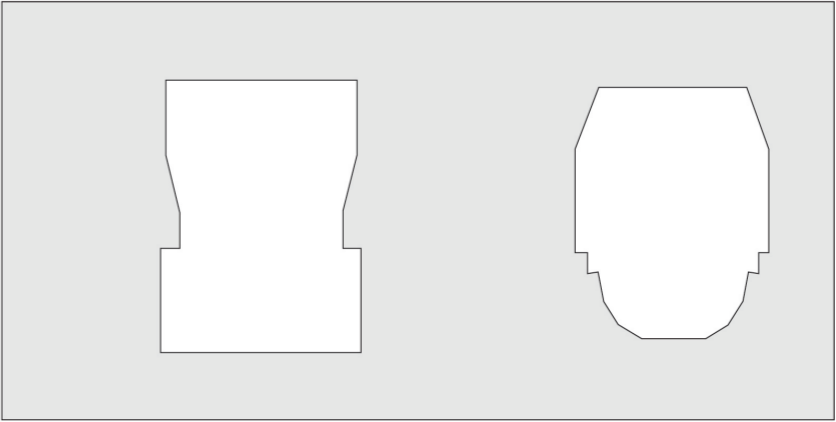

Amare

WELKOM BIJ BINCKORST!

