

9TH, TOP FLOOR 1:200

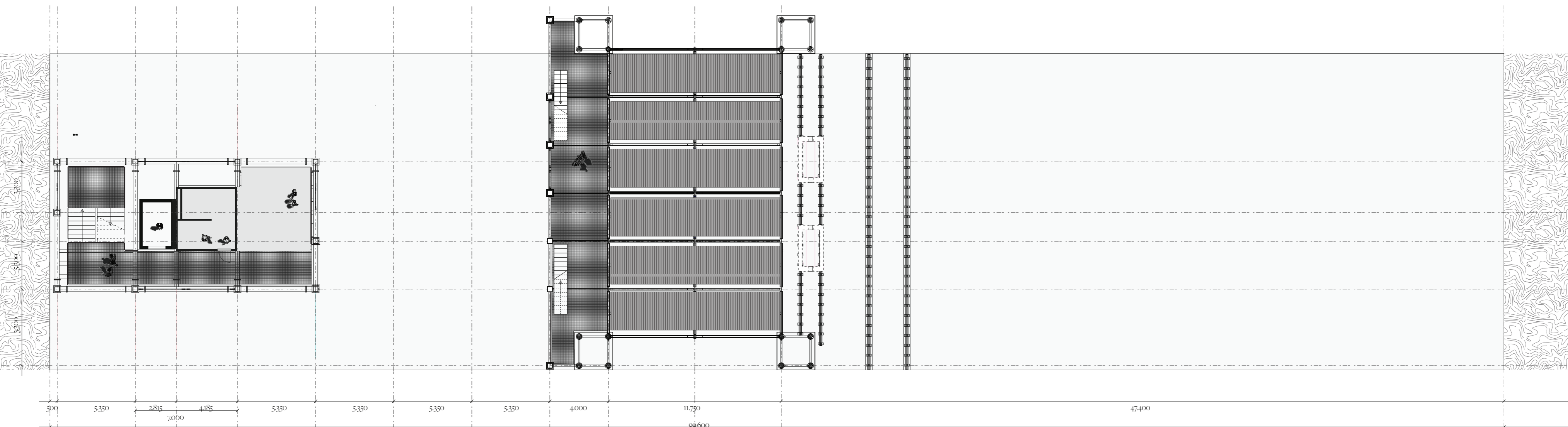

4TH-6TH-8TH FLOOR 1:200

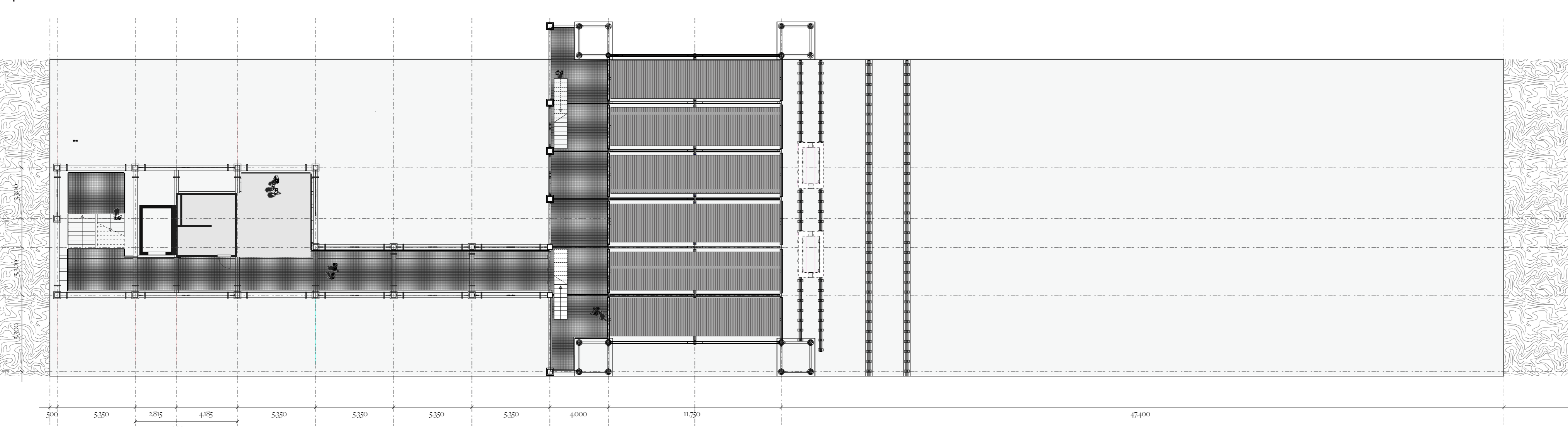

2TH FLOOR 1:200

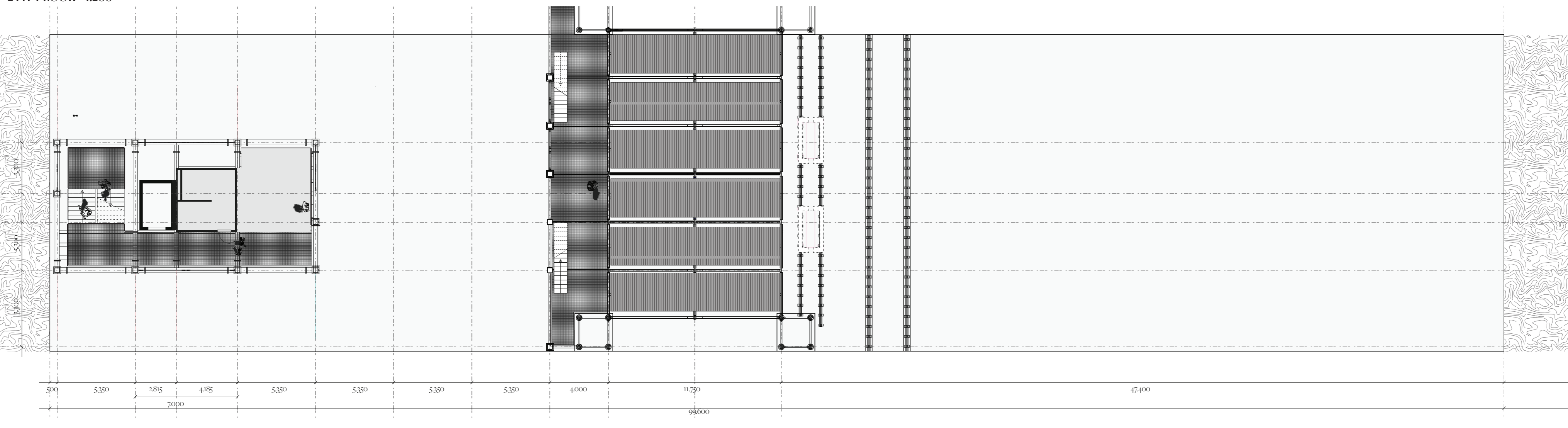

1TH-3TH-5TH-7TH FLOOR 1:200

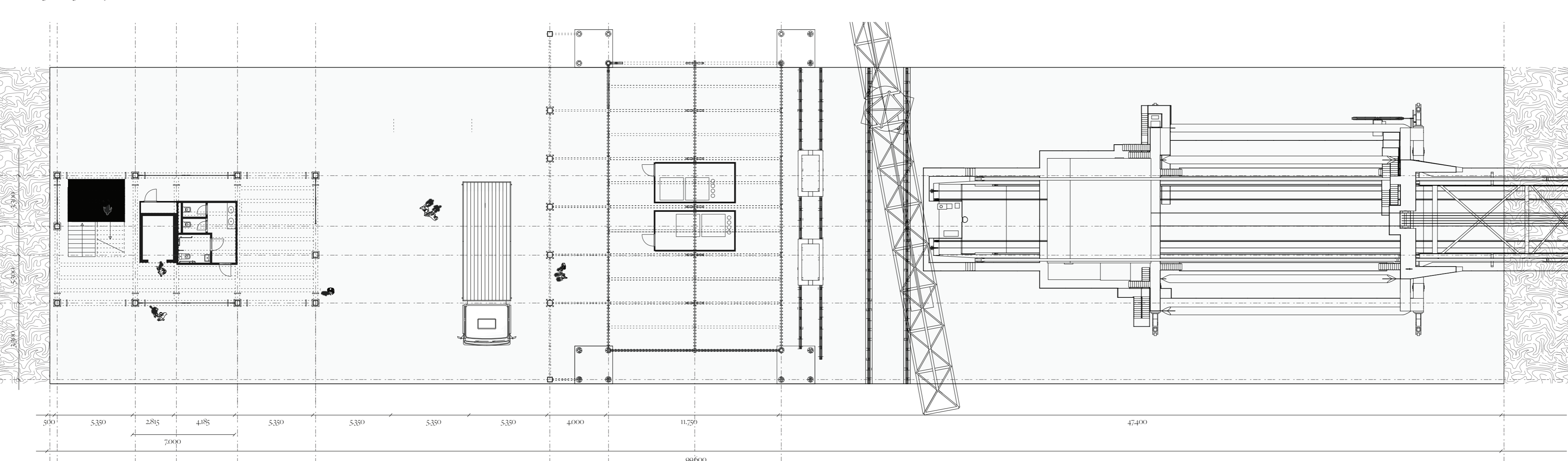

GROUND FLOOR 1:200

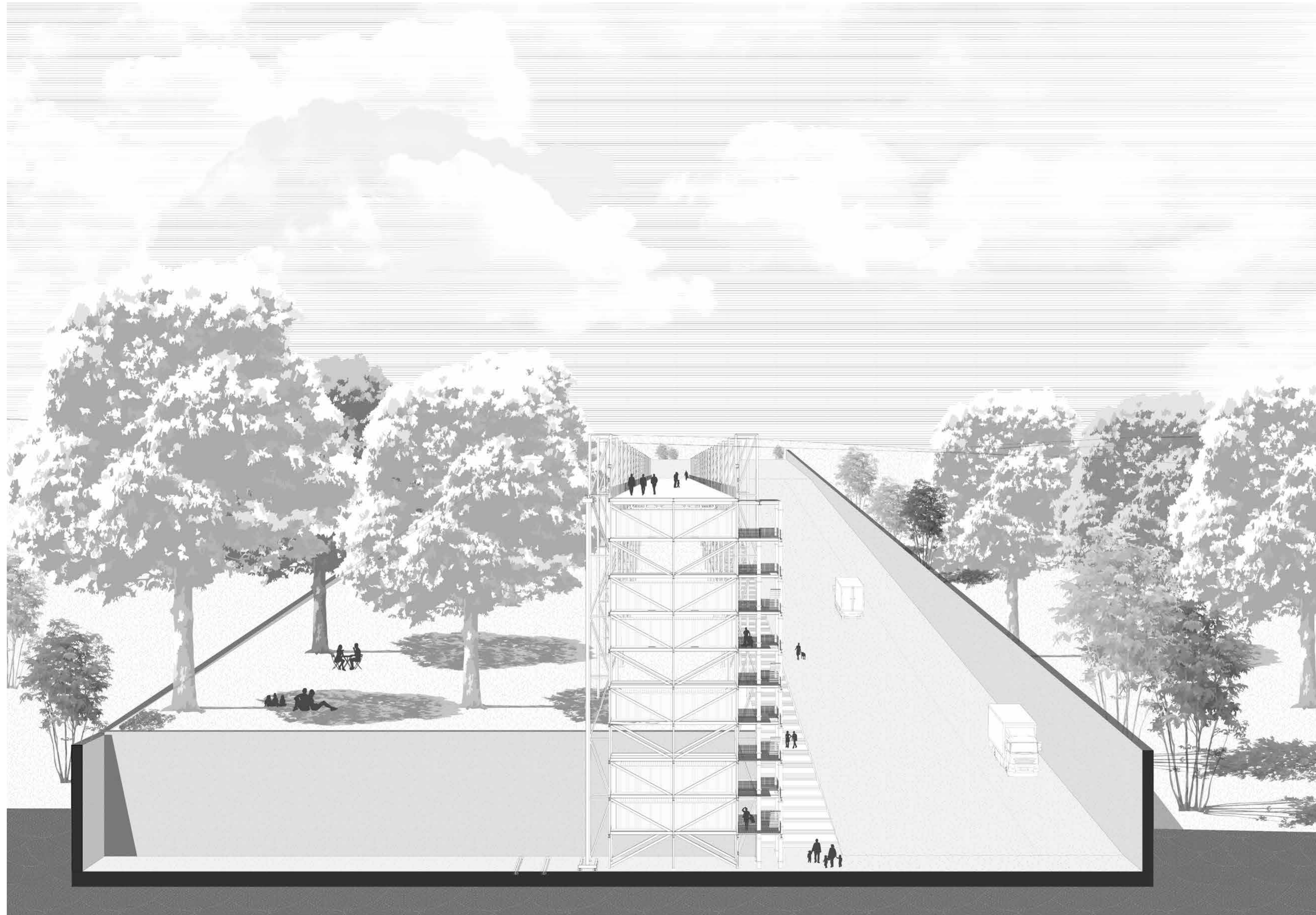

PERSPECTIVE SECTION - 1:200
Marilou van Dalen - Borders & Territories - 30.10.2023

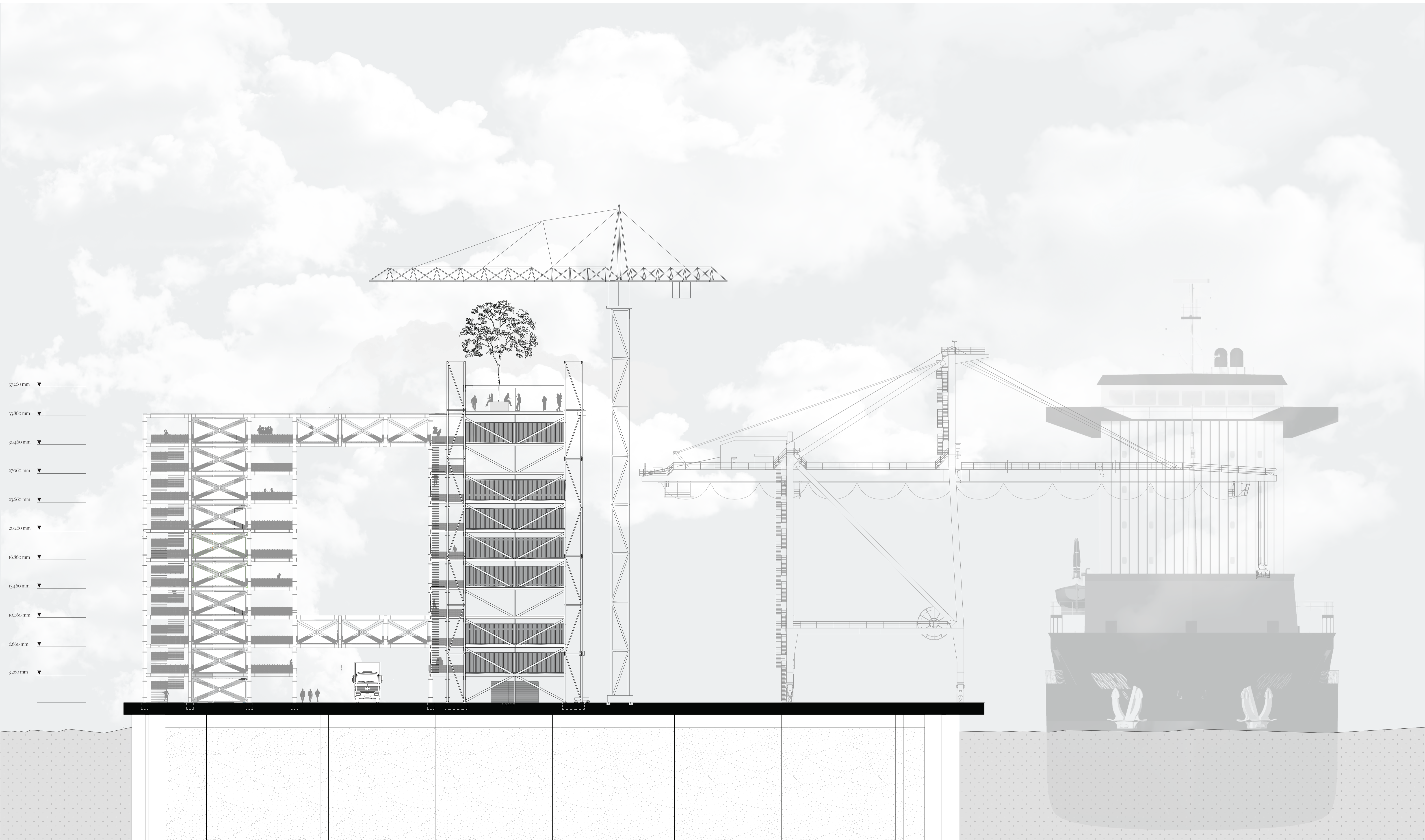

SHORT SECTION - 1:200
Marilou van Dalen - Borders & Territories - 05.10.2023




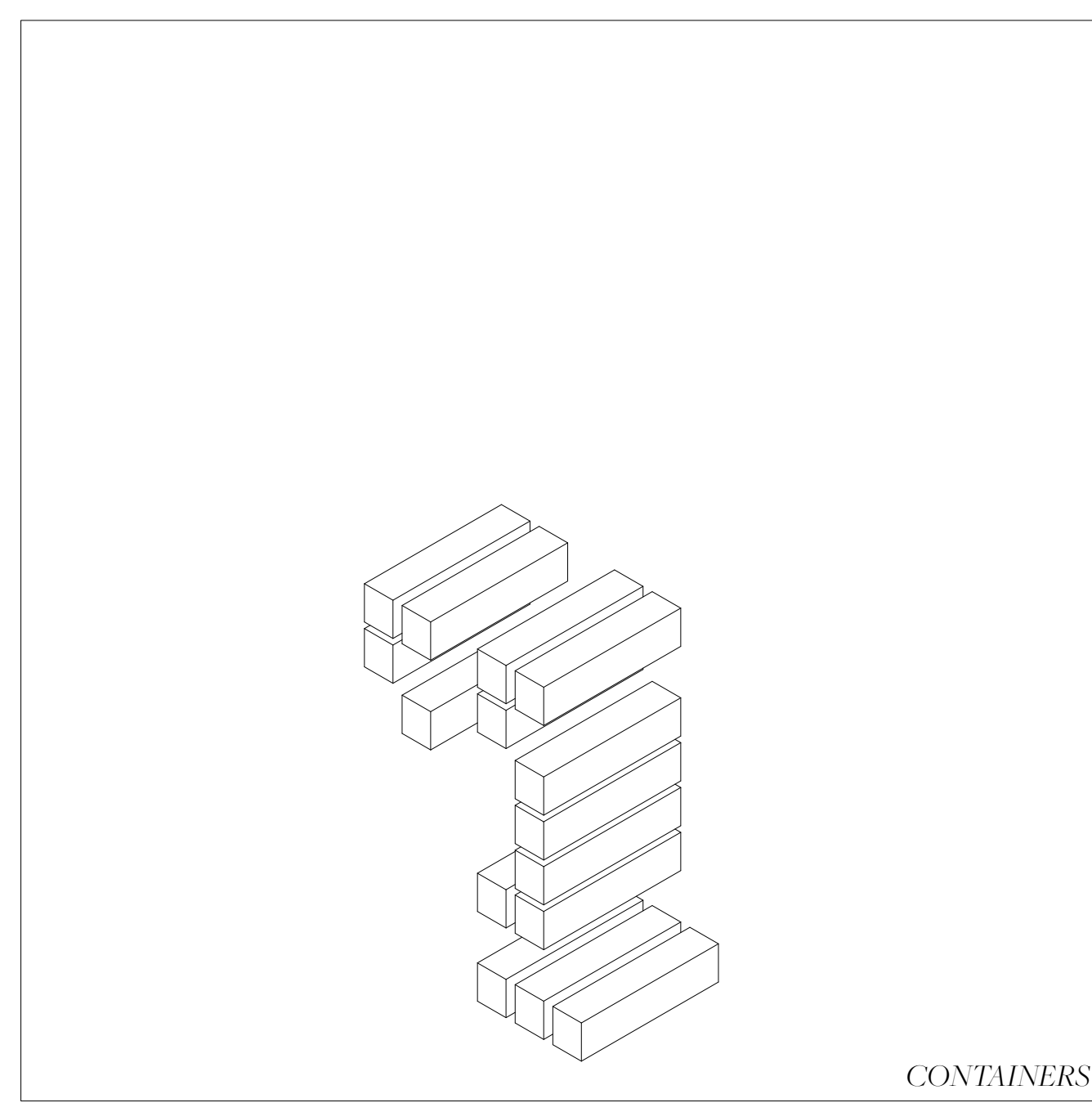
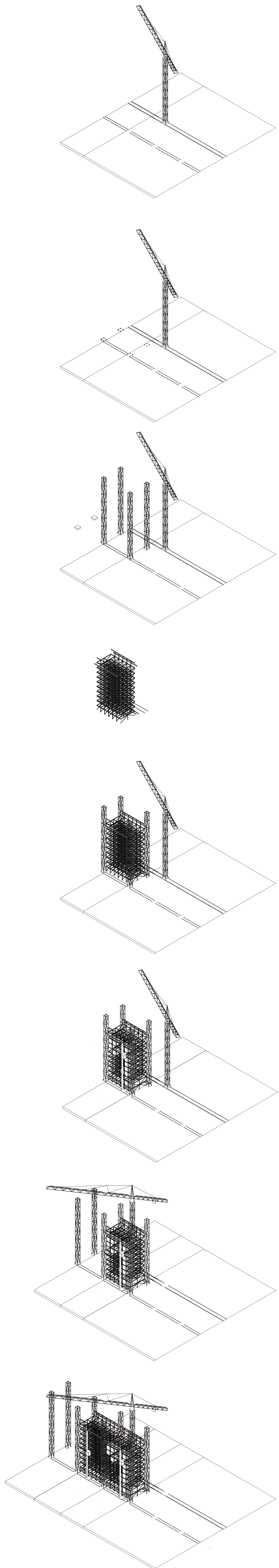

CONTAINERS

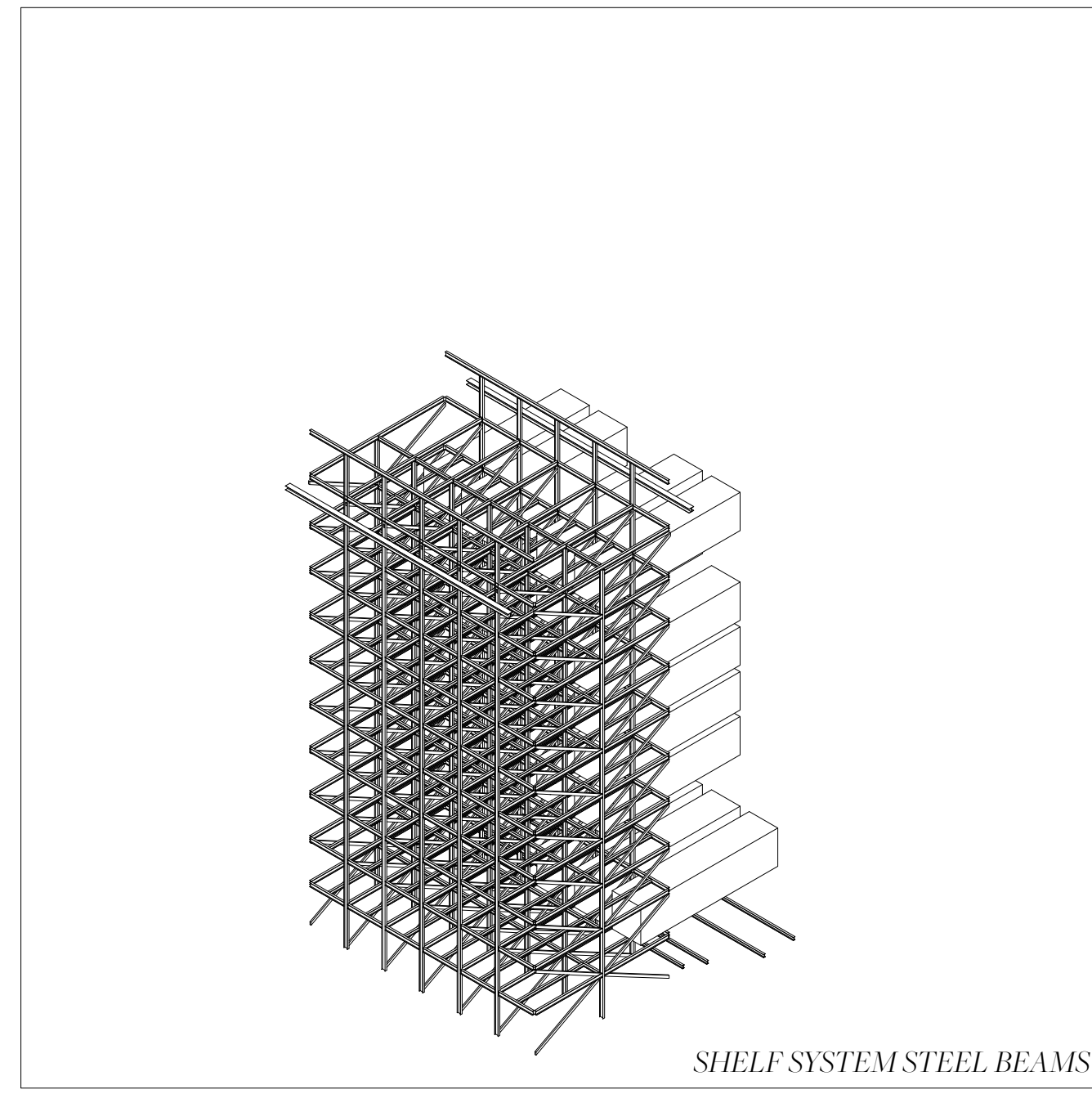

SHELF SYSTEM STEEL BEAMS

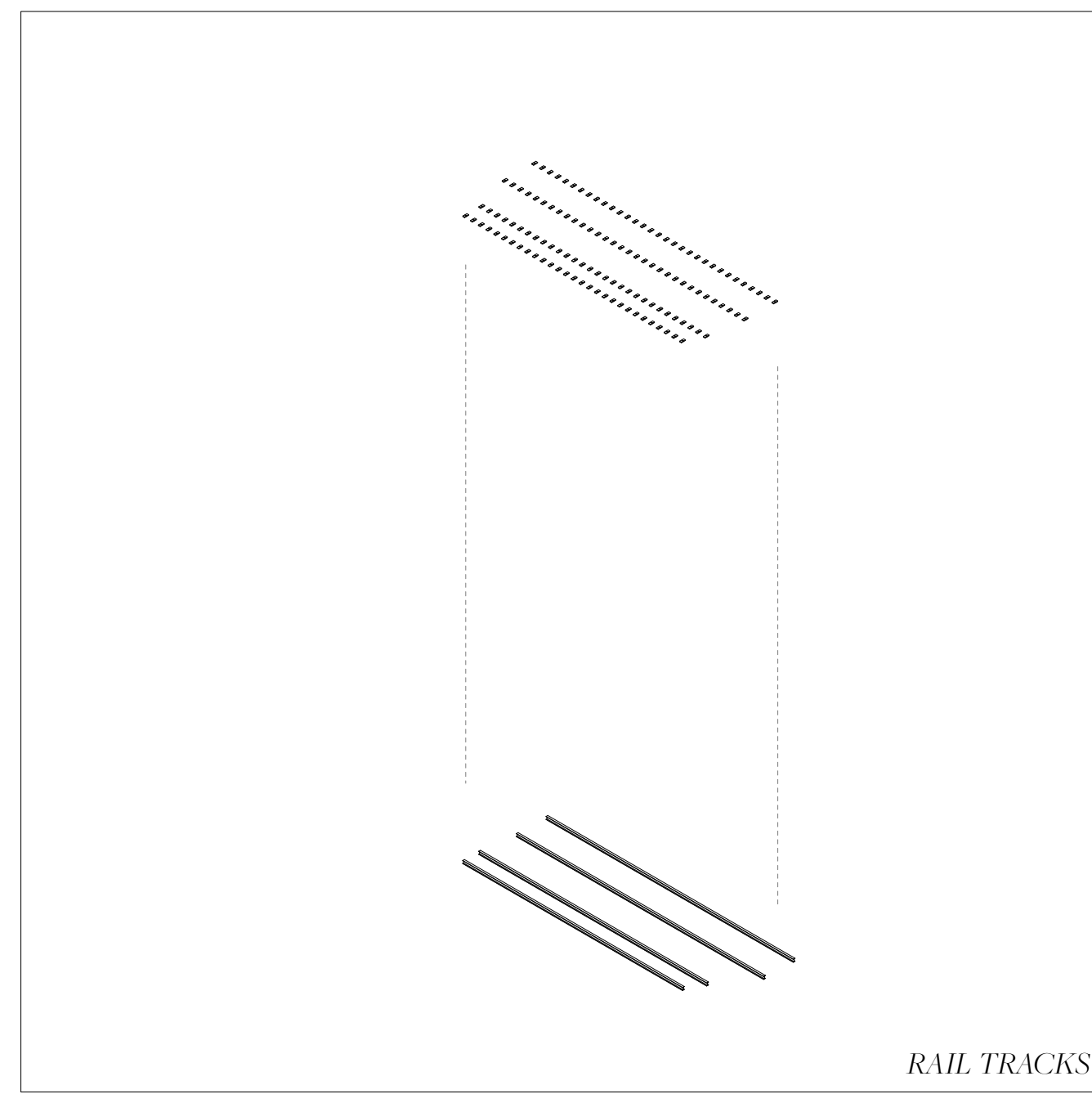

RAIL TRACKS

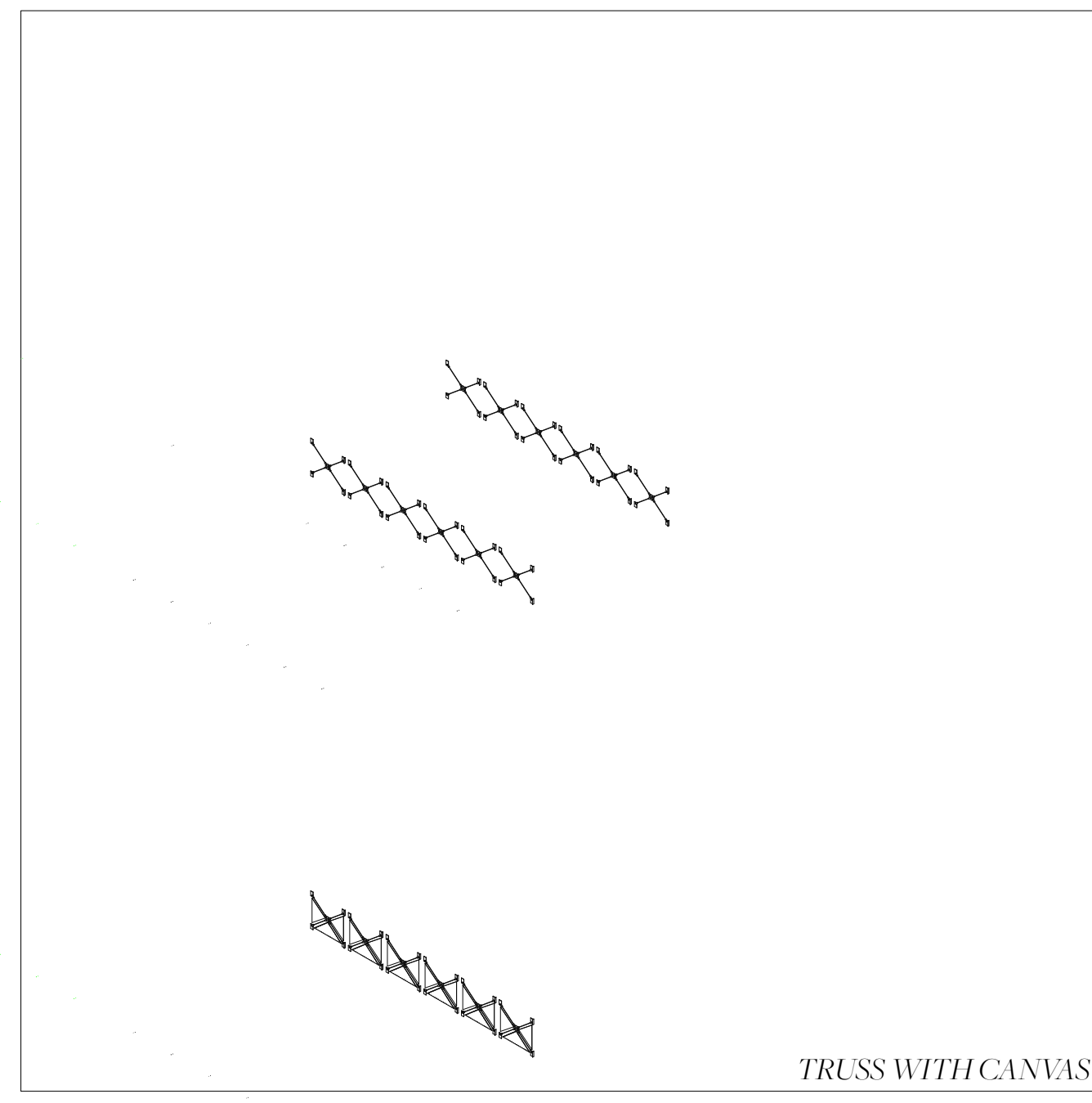

TRUSS WITH CANVAS

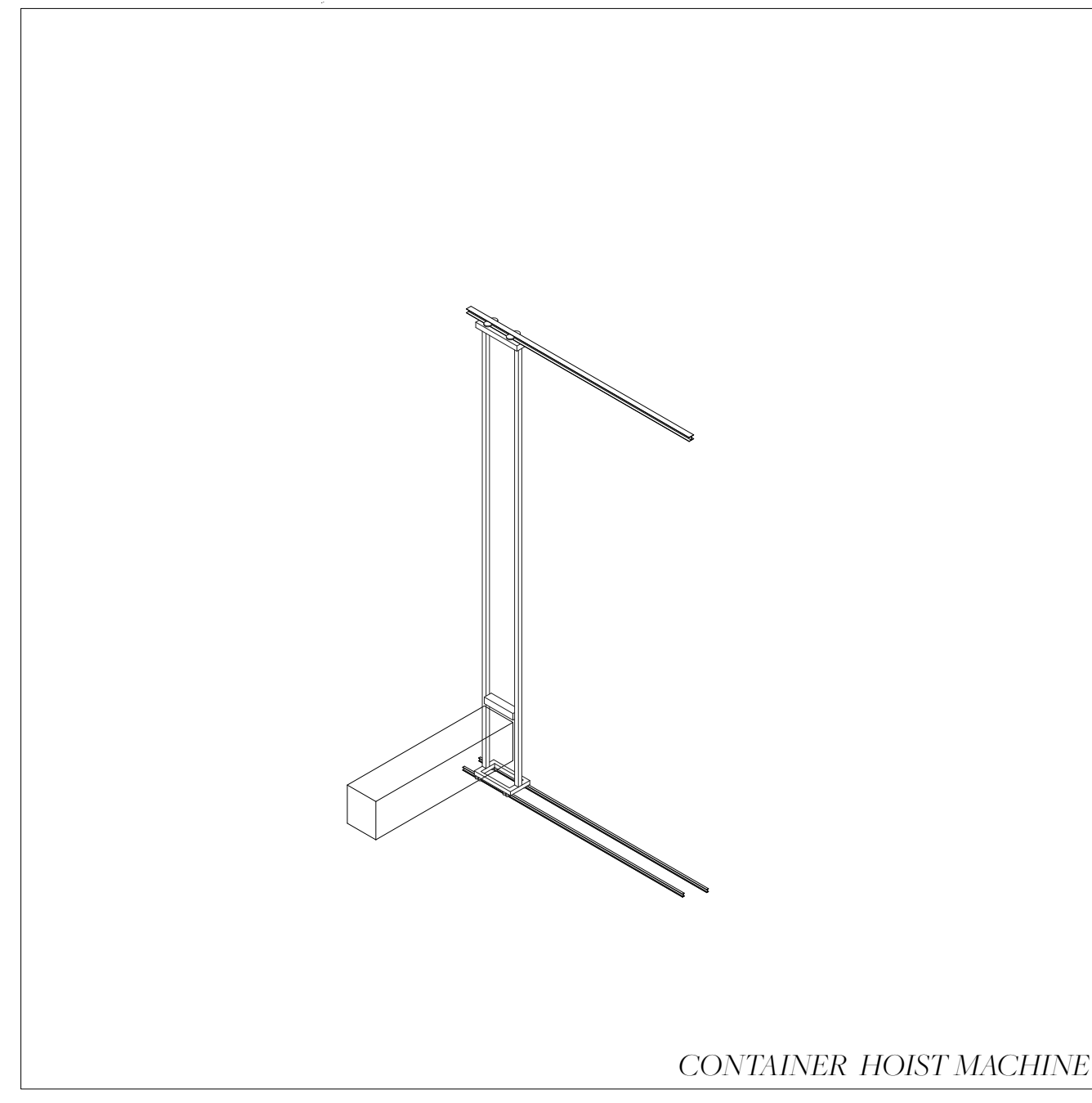

CONTAINER HOIST MACHINE

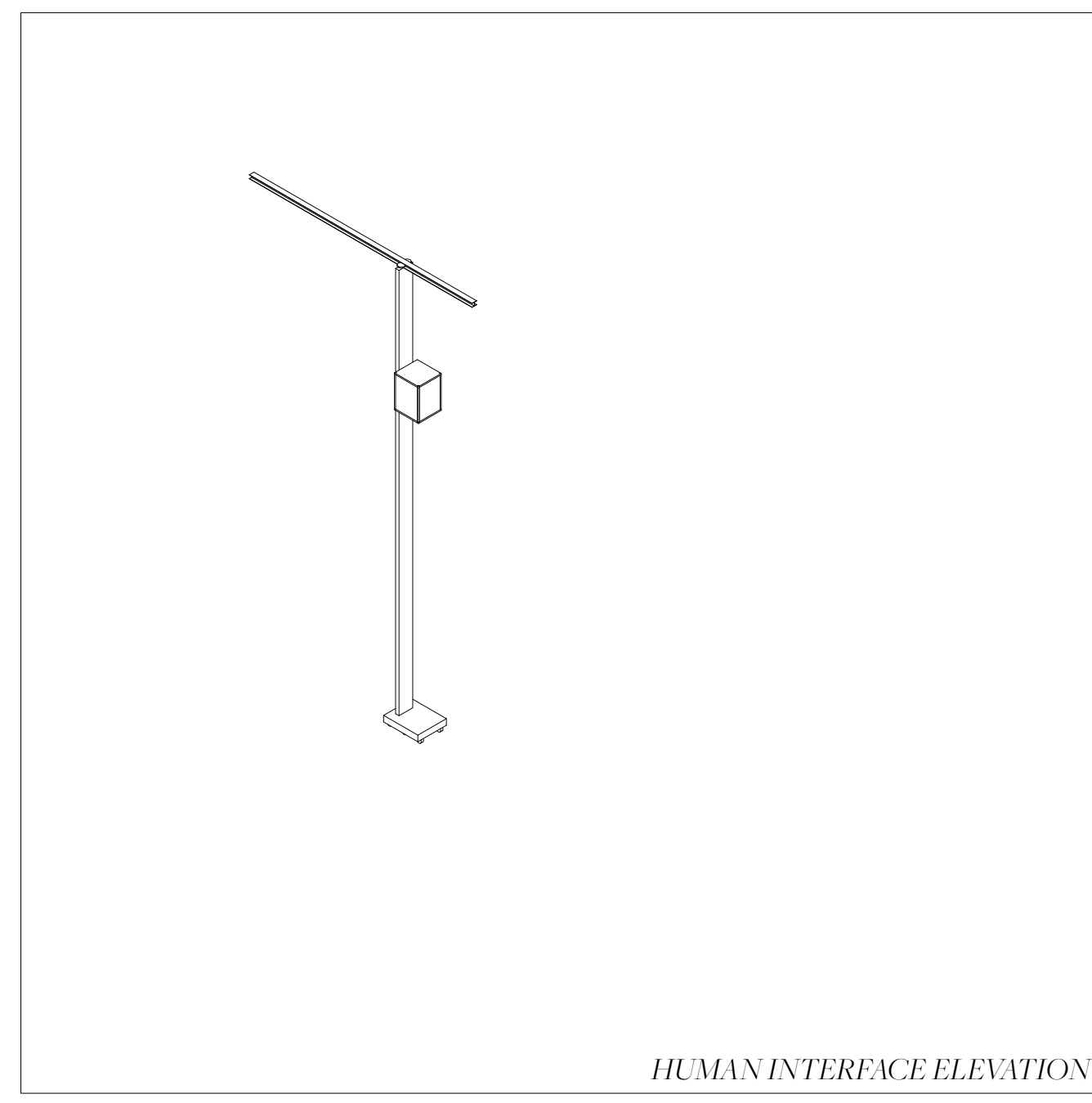

HUMAN INTERFACE ELEVATION

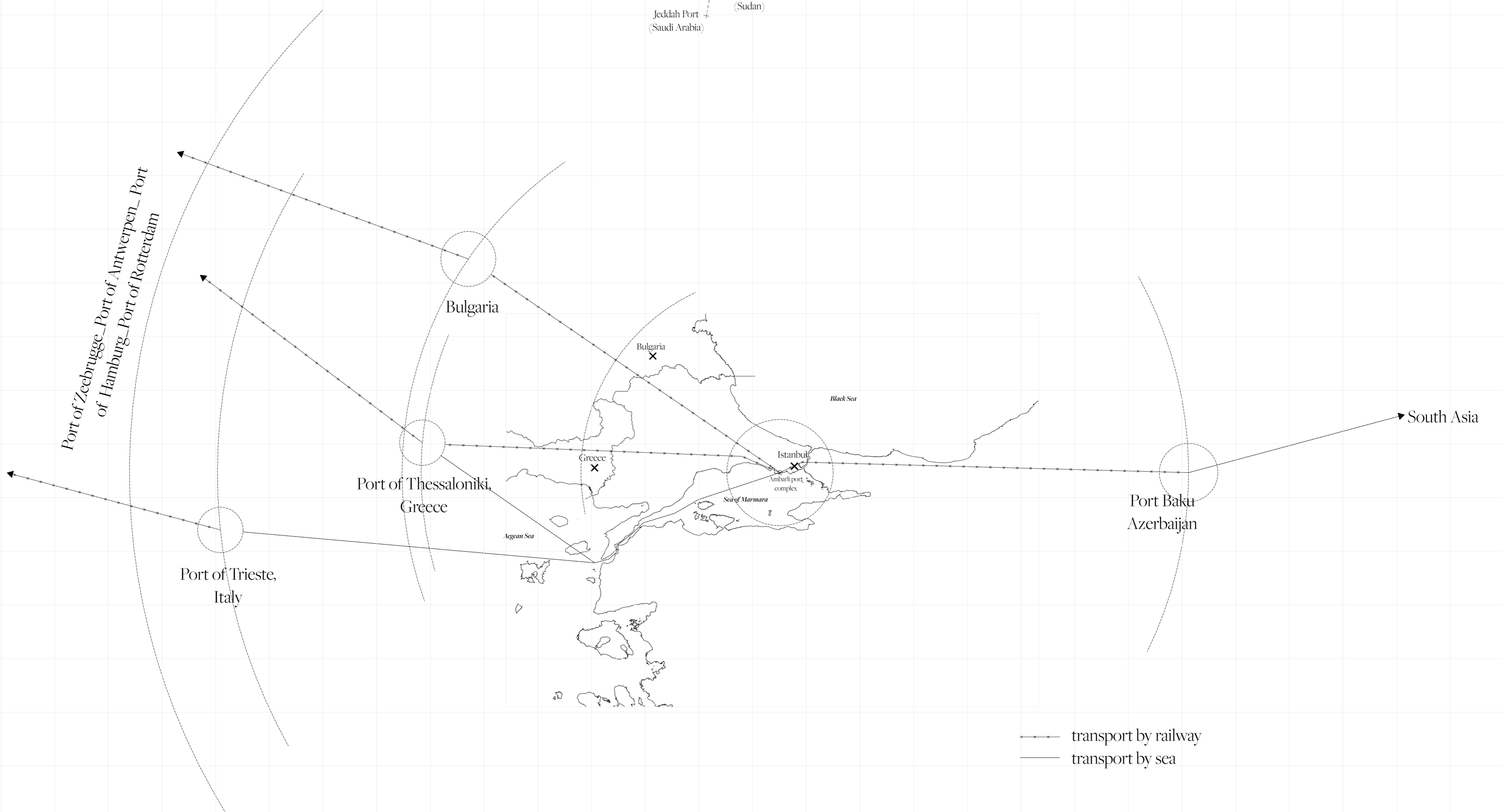
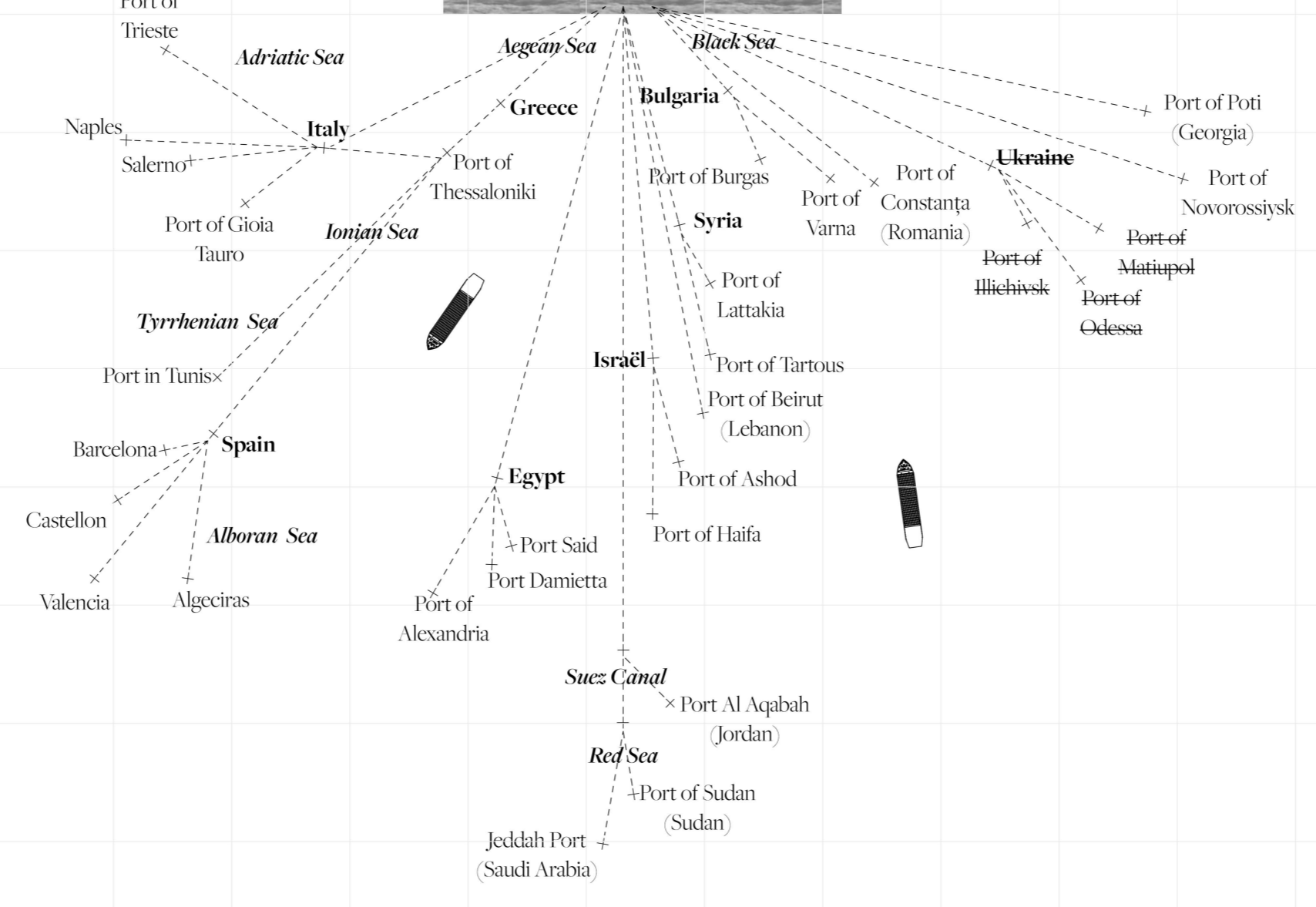
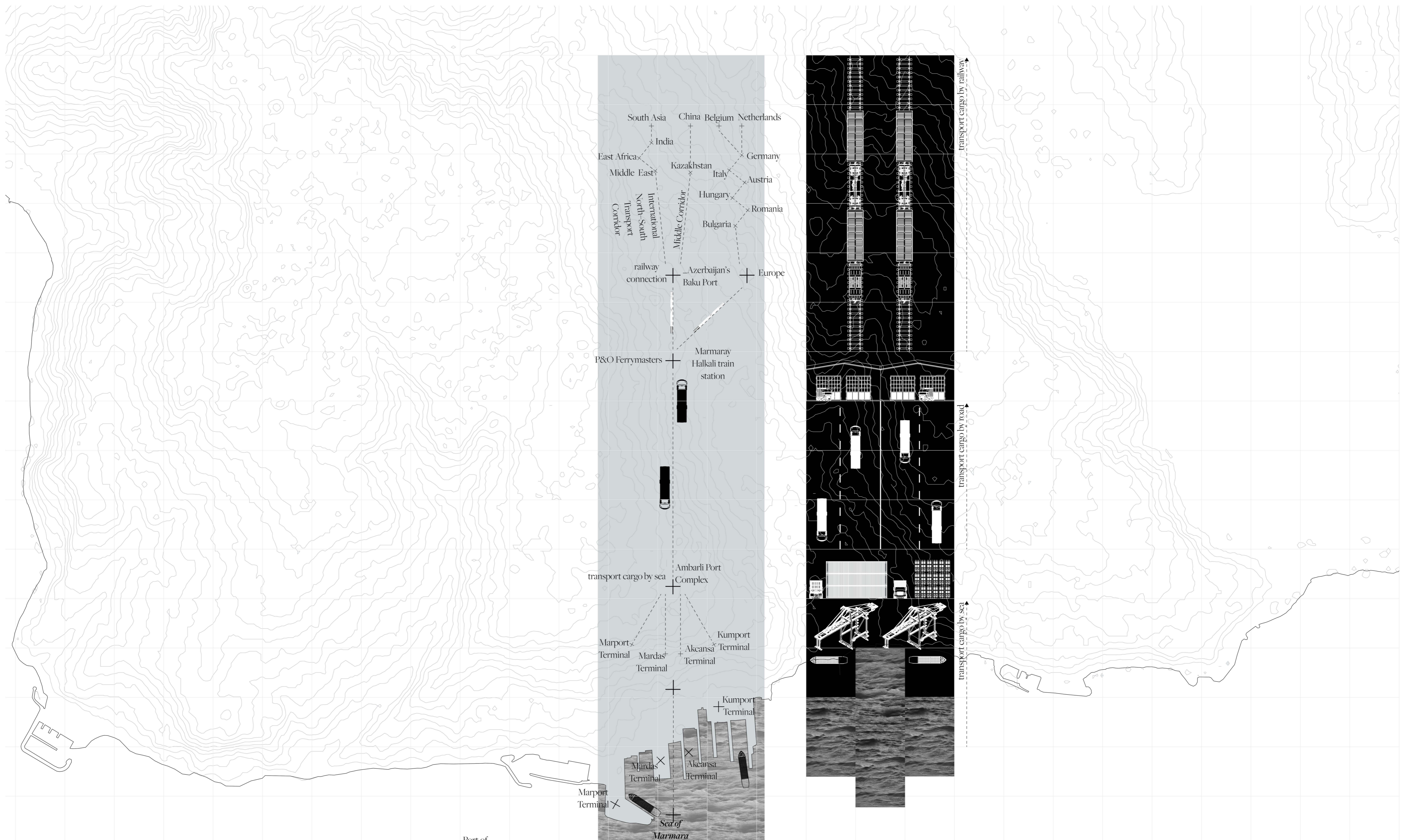



towards Bosphorus strait



sea of Marmara



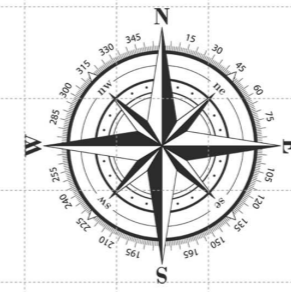



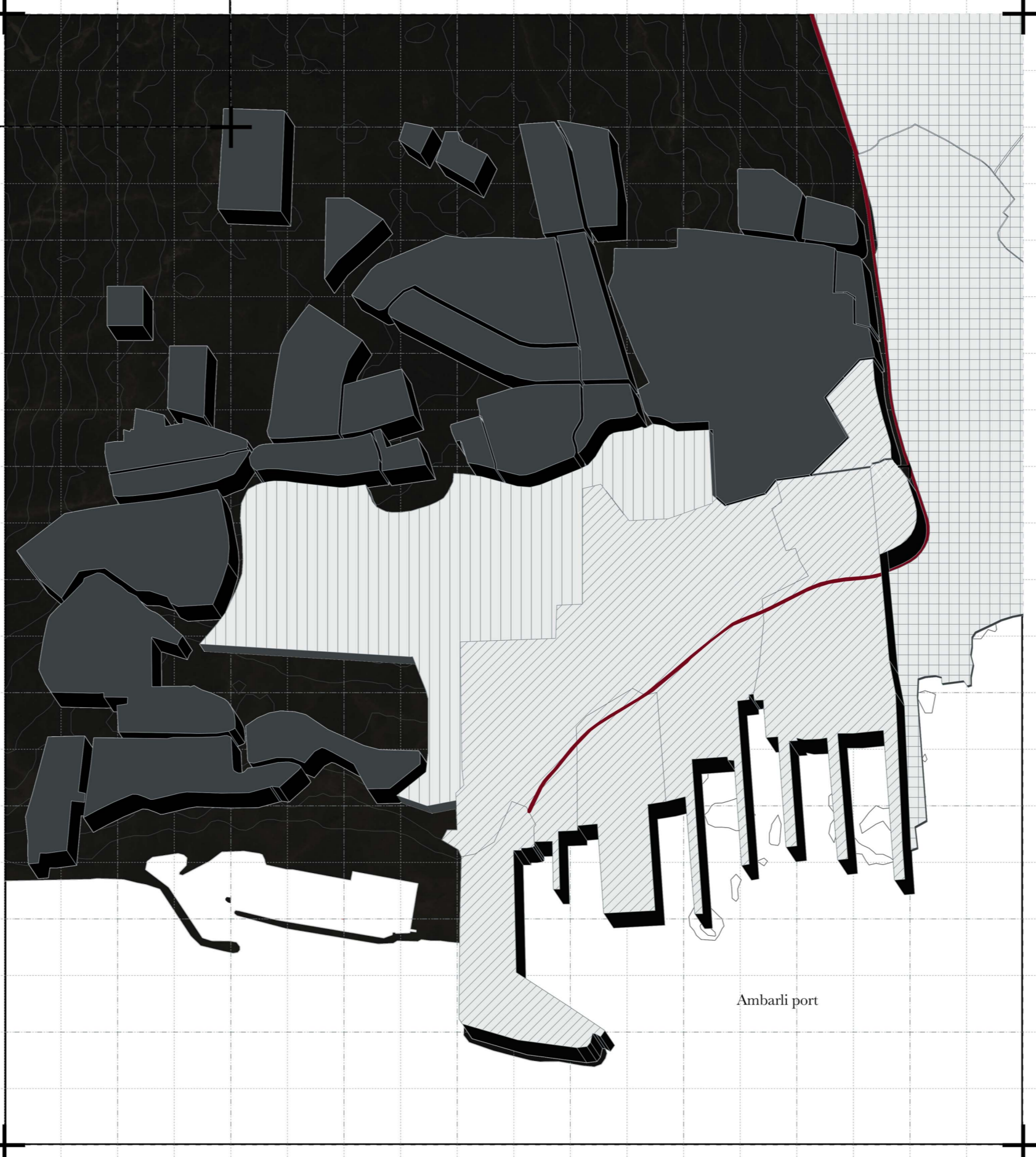

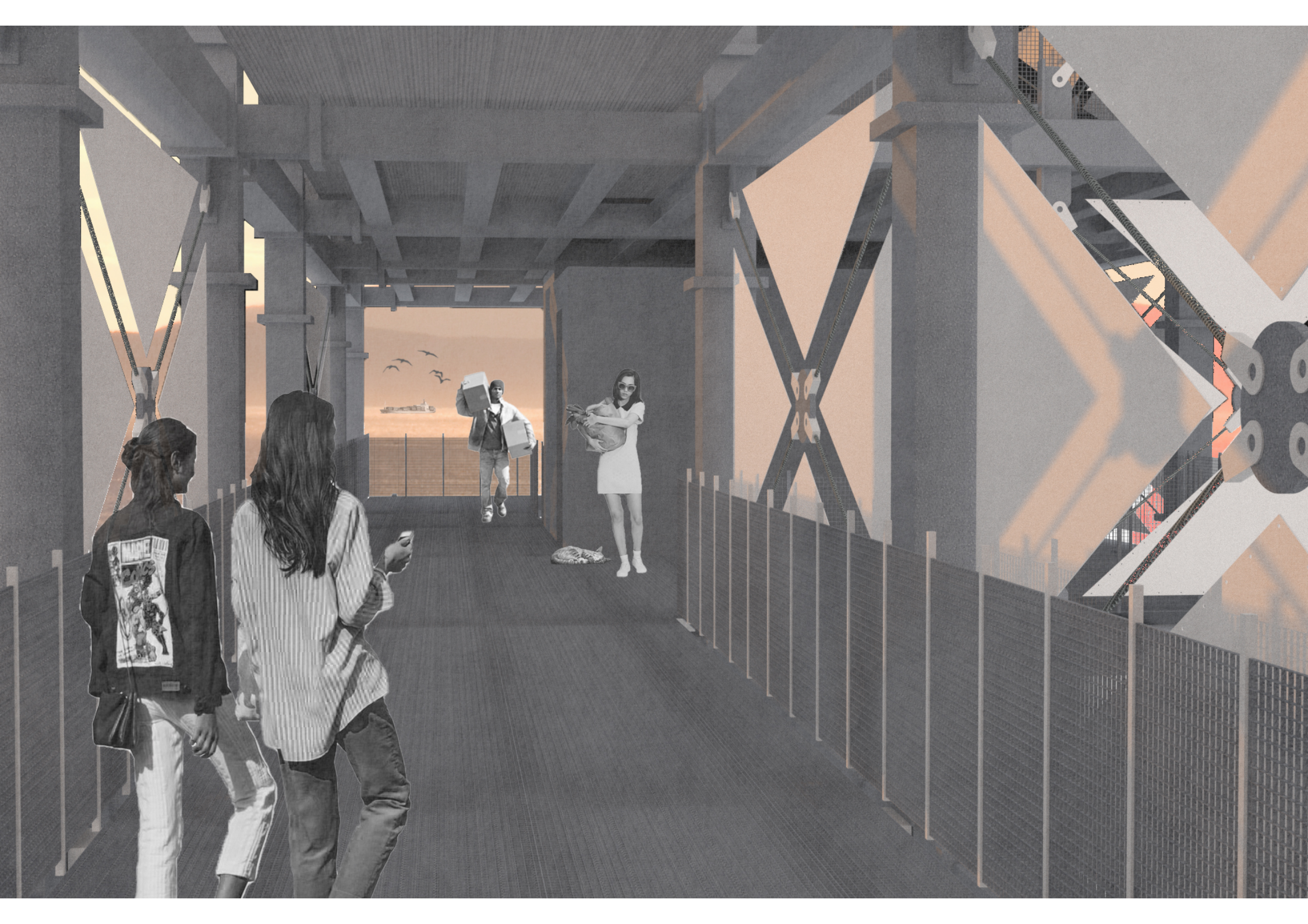

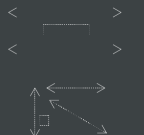





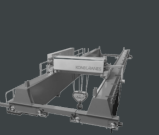
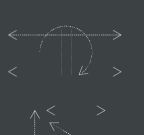

1 km 2 km



-  area under construction
-  industrial green
-  industrial area
-  industrial area | Ambarli port complex
-  residential area
-  residential area | gated community
-  railway
-  highway



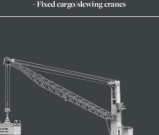
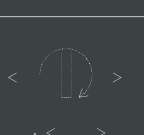

Port Machinery	Motions	Tasks
 Container ship to shore STS cranes		Lifts containers on and off ships, using a long horizontal arm called the boom. A specialized operator sits in a glass cabin which is connected under a device called a trolley. The crane driver can lower by winches the spreader onto the top of a container which then locks onto the container using device called twist locks. They are electrically driven and have a supporting framework that sits and selection rails so that they can move along the wharf to line up with the ship. A container ship may have up to 3 container cranes working on it simultaneously.
 Straddle Carrier		Unmanned vehicles to move containers within a container terminal. They move containers either to or away from the dock. The straddles are also used to load/unload trucks with containers. The straddles can be operated by a driver or they exist as automated, autonomous vehicles. The computers tell them which containers they need to pick up. They pick up containers by a spreader which is placed on top of the container and locks into it using specialized twist locks. Straddles stack an average of 3 containers high for storage in rows that allow the straddle to drive up and down over the stacks while carrying another container.
 Reach Stackers		off road vehicles used to transport containers from one mode of transport to another. They are faster and more flexible than forklifts. They are operated by a driver who sits in a cabin at the front of the vehicle which has a long arm. There are also autonomous/automated reach stackers. Reach stackers can pick up containers by using a device called a spreader at the end of its long arm. They can use their long and flexible arm to stack containers up to 4 rows deep.
 Empty container handler		Transport containers and stack them in rows up to 7 containers high. They handle empty containers. They exist as automated vehicles or operated by specialized drivers who sit in a cabin in the middle of the vehicle. The vertical arm can be about 20m high.
 Bulk grabs		Some cranes are used to unload bulk from ships of certain types of dry, loose, solid materials. They use a set of metal jaws called the bulk grab, attached to the end of cables from the crane.
 double Travelling Gilder overhead gantry crane		Commonly called a bridge crane, it consists of two parallel rails (or longitudinal beams) attached to opposite ends of columns by means of trolleys. The hoist is the lifting component of a crane, travelling along the bridge if the hoist is rigidly supported on rails or on casters running on two fixed rails at ground level, the crane is called a gantry crane. Gantry cranes used in different building situations, they offer maximum flexibility, available in numerous configurations. The travelling feature means mobility of the crane in the way it travels within an area of operation. They can be electric or hydraulic drive. They can be remotely controlled.
 Rotary overhead crane		Rotary hoisted crane are the system that can be changed to overhead cranes as well as gantry cranes. It contains a 90° rotation movement coupled to the trolley.
 mobile or fixed Rail mounted gantry crane rotating. Single girder gantry cranes, double girder gantry cranes & semi gantry crane		Type of heavy crane, travelling on fixed track. Steel frame, hoisting mechanism, spreader and shifting mechanism, crane travel mechanism, trolley travel mechanism, container spreader. They exist in variations of from jacking trolleys and are electrically powered. Semi automatic or auto-mated deployment.
 Portal cranes mobile slewing cranes		The vertical support members on a portal crane may be anchored to the ground, or mounted on wheels or tracks that allow the crane to move throughout the area. Portal cranes being the empty space straddled by the gantry are a type of crane used to straddle an object or workpiece and the entire crane can be moved about a workpiece. Slewing cranes (a slewing crane lifts its load, suspends that load in mid-air, and then rotates it via boom rotating mechanism. Non-slewing cranes on the other hand lack a rotating base section. A crane installation mounted on a portal with utmost mobility given through rubber tires. A portal crane on wheels.
 Portal cranes Fixed cargo-slewing cranes		Areas of application: (container handling, stacking, bulk handling, scrap handling, heavy lift, general cargo) Fixed cargo cranes (FCC) are space saving handling solutions for smooth up to open frame class. The slewing cranes installed on fixed foundation on pedestals comprise both cylinder lifting as well as wire lifting, slewing or double girder cranes. They provide the optimum balance between restricted space and cost effective turnover.
 Mobile slewing crane		Mobile cranes are designed to use a collection of simple machines in order to both raise and lower objects, as well as to move them horizontally. This type of crane can be easily moved from one location to the next.
 Portal cranes Fixed cargo-slewing cranes		Horizontal displacement of the trolley and movement by means of lift. Top-slewing cranes are the large construction sites most strategic equipment for productivity. Whether on large infrastructure, high rise buildings, crowded urban centers or wide open sites, they make it possible to hoist and distribute loads high and far.

