

MUSIC MEETS ARCHITECTURE

CONTENTS

1

introduction

fascination
problem statement
objective

2

research

questions
method
interviews
analysis
conclusion

3

design

experience
why
acoustic concept
climate concept

4

construction

building process
details

CONTENTS

1

introduction

fascination
problem statement
objective

2

research

questions
method
interviews
analysis
conclusion

3

design

experience
why
acoustic concept
climate concept

4

construction

building process
details

CONTENTS

1

introduction

fascination
problem statement
objective

2

research

questions
method
interviews
analysis
conclusion

3

design

experience
why
acoustic concept
climate concept

4

construction

building process
details

CONTENTS

1

introduction

fascination
problem statement
objective

2

research

questions
method
interviews
analysis
conclusion

3

design

experience
why
acoustic concept
climate concept

4

construction

building process
details

INTRODUCTION

FASCINATION



PROBLEM STATEMENT

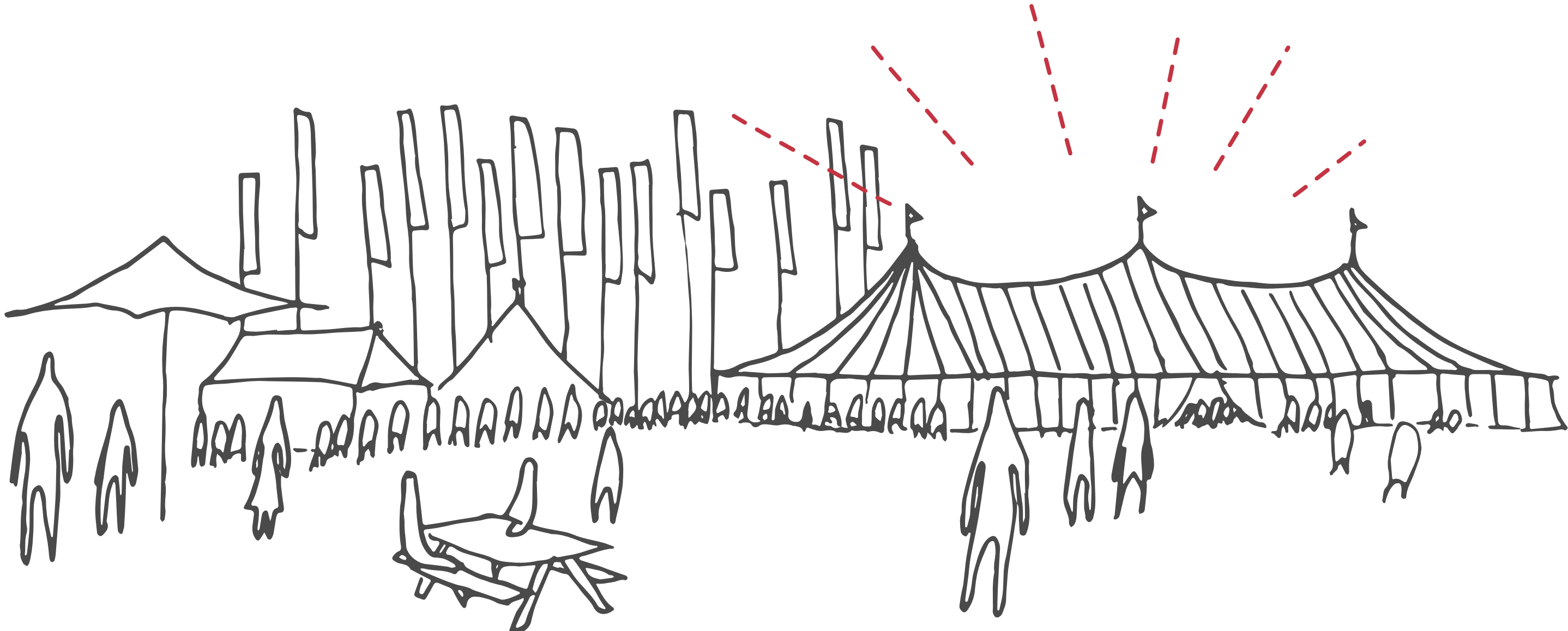

PROBLEM STATEMENT

acoustic problem - high frequencies

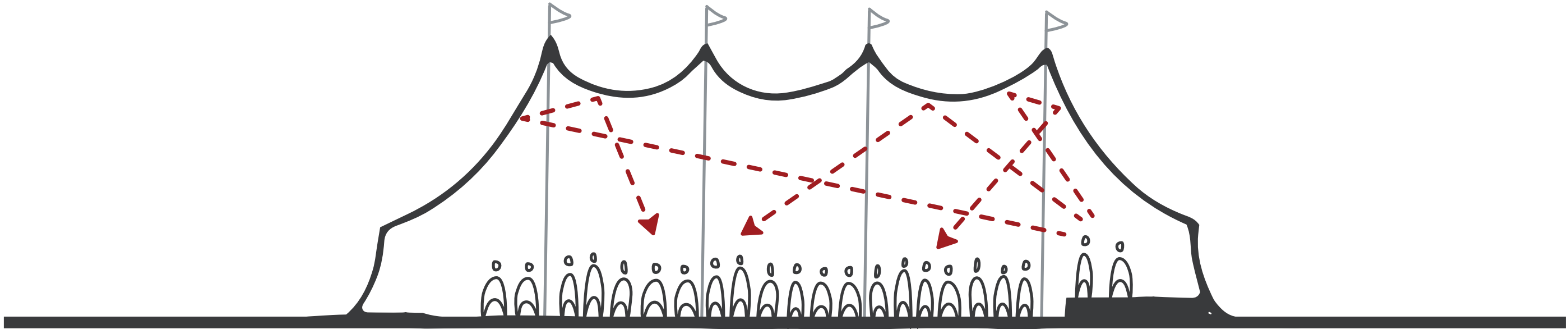

Source: M. Mols (2016)

PROBLEM STATEMENT

acoustic problem - low frequencies

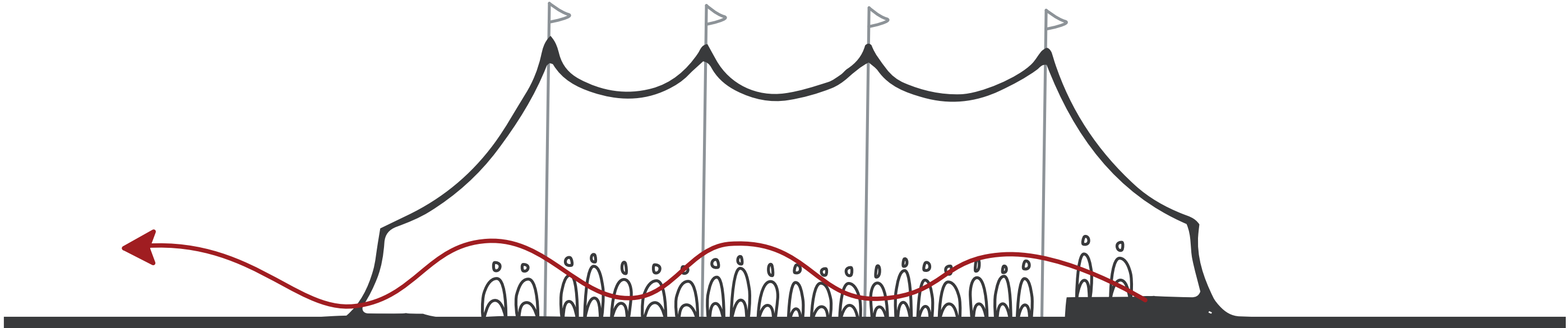

PROBLEM STATEMENT

acoustic problem - low frequencies

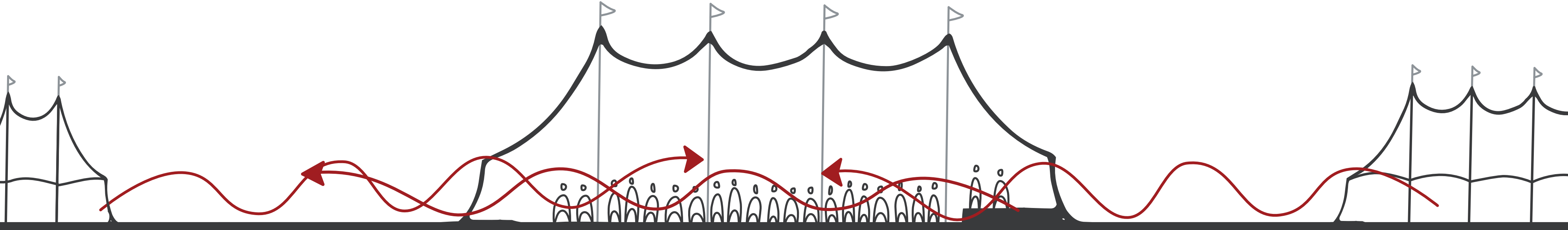

Source: M. Mols (2016)

PROBLEM STATEMENT

supports and guy ropes

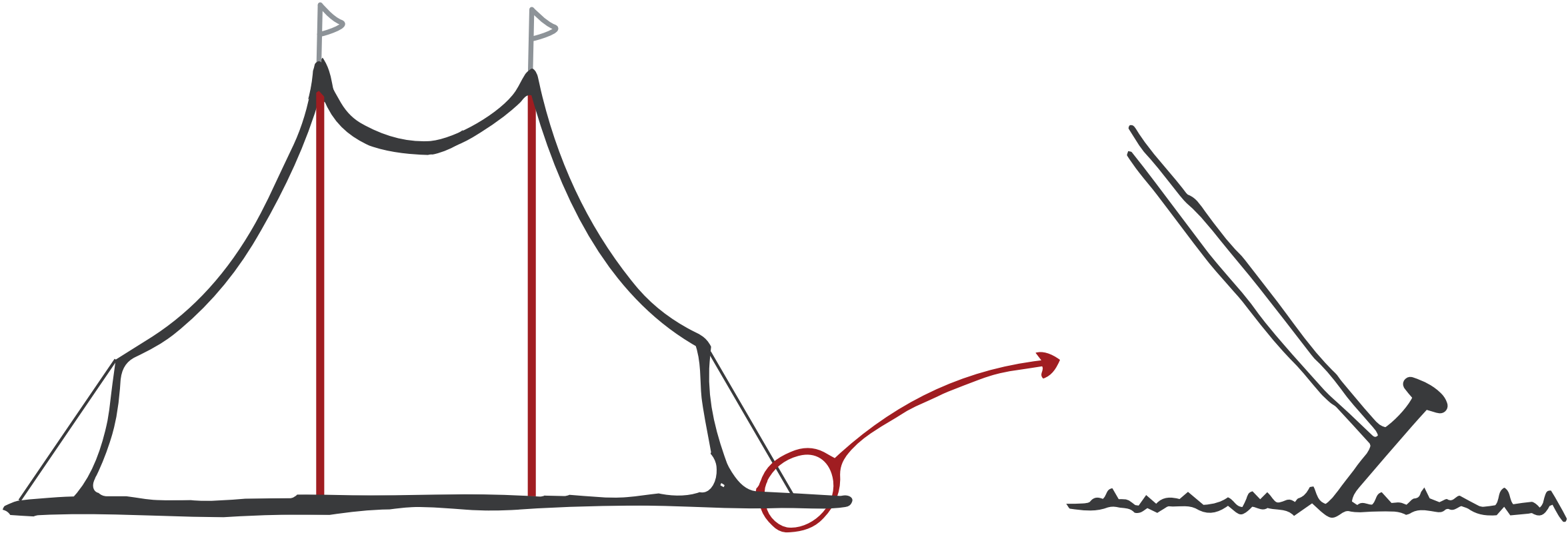

PROBLEM STATEMENT

universal design

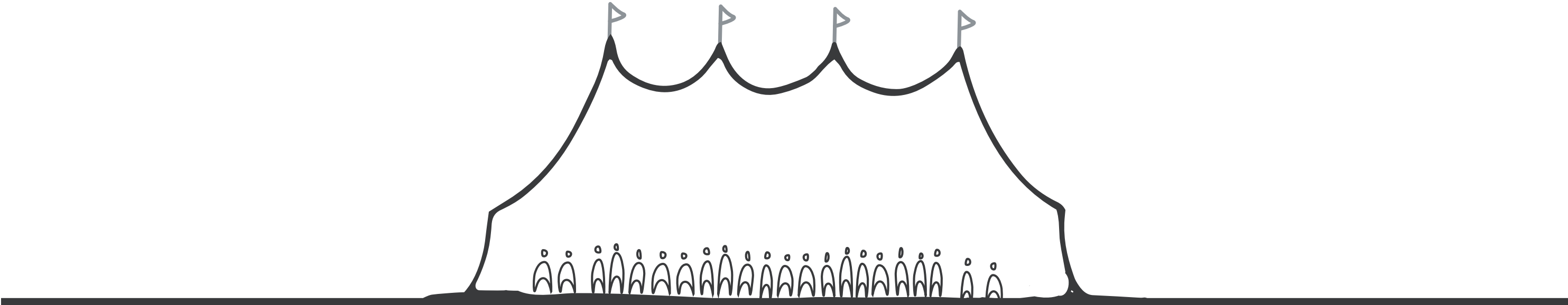

PROBLEM STATEMENT

universal design

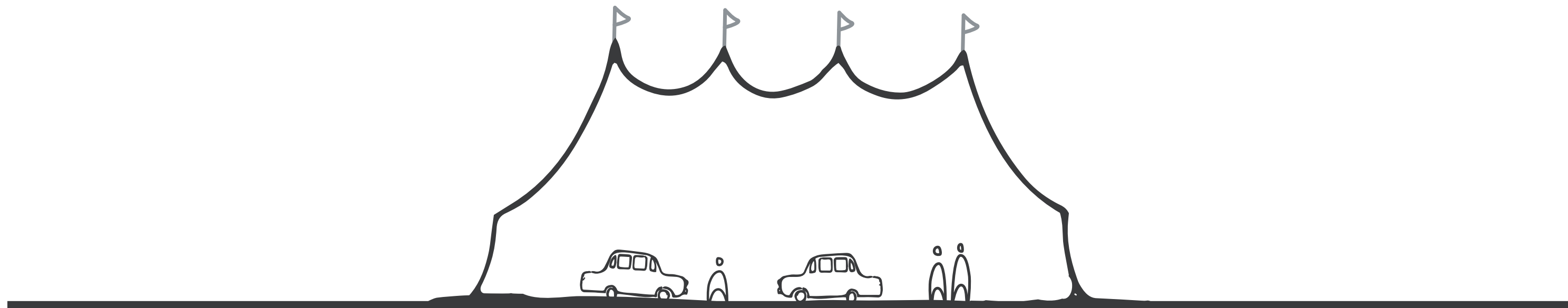

PROBLEM STATEMENT

universal design

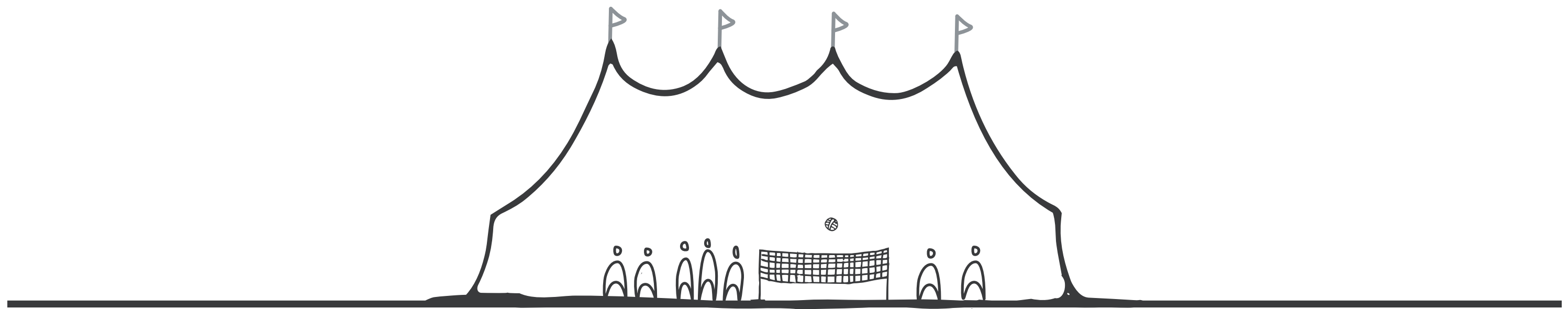

PROBLEM STATEMENT



Bad sound quality, can cause hearing damage



No added value to the user experience



designed for many purposes

PROBLEM STATEMENT



Bad sound quality, can cause hearing damage



No added value to the user experience



designed for many purposes

PROBLEM STATEMENT



Bad sound quality, can cause hearing damage



No added value to the user experience



designed for many purposes

OBJECTIVE



improve acoustics



design for the experience
of the visitor



design specifically for
pop music events

OBJECTIVE



improve acoustics



design for the experience
of the visitor



design specifically for
pop music events

OBJECTIVE



improve acoustics



design for the experience
of the visitor



design specifically for
pop music events

LOCATION - LOWLANDS

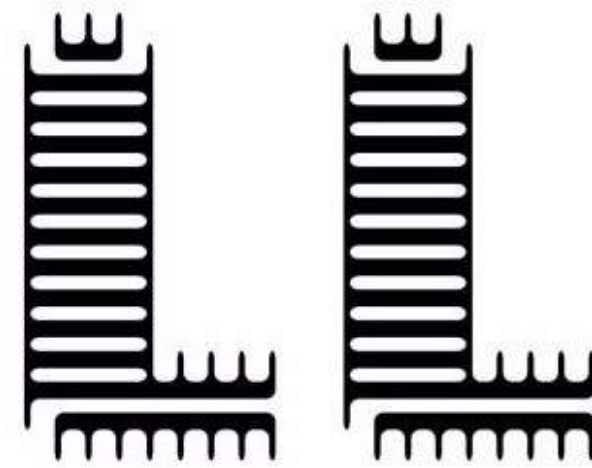

55 000	visitors
3	days
175	euro per ticket
8	music stages
4	cultural stages
2	nightclubs
252	acts

LOCATION



atmosphere

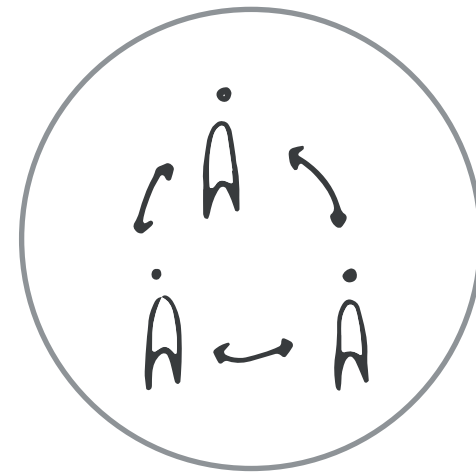

community

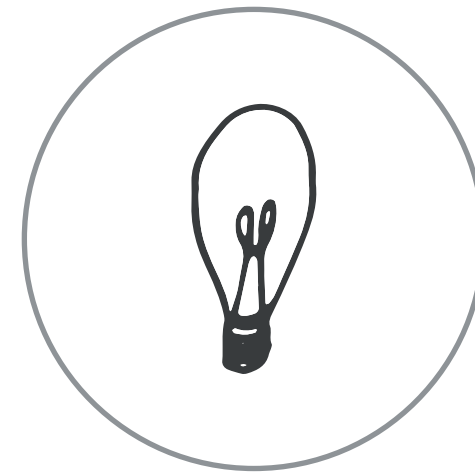

innovative

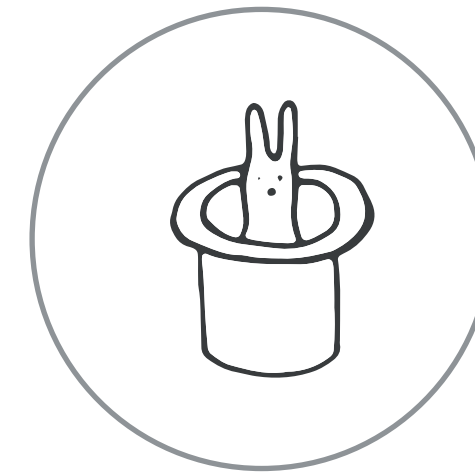

discover

OVERALL DESIGN QUESTION

How can a **temporary performance place** be designed that is **innovative** and contributes to the **experience of the audience** at a live pop music performance at **Lowlands festival**?

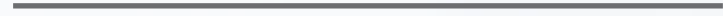

RESEARCH

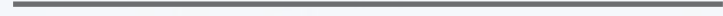

RESEARCH QUESTION

What aspects of a performance place contribute to the experience of the performance at a pop music festival?

SUB QUESTIONS

What creates a good performance place at a pop-music festival for:

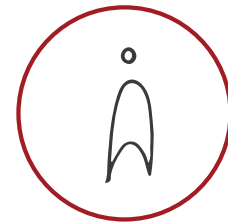

the visitor

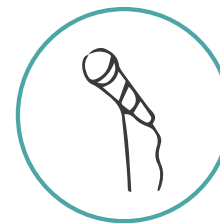

the musician

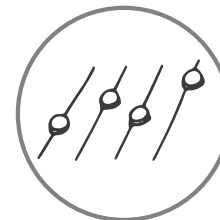

the sound engineer

METHODS

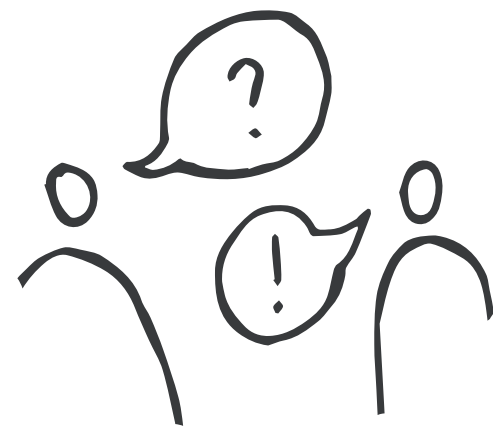

interviews

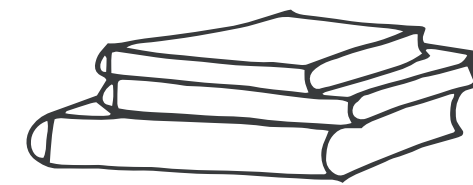

literature study

METHODS

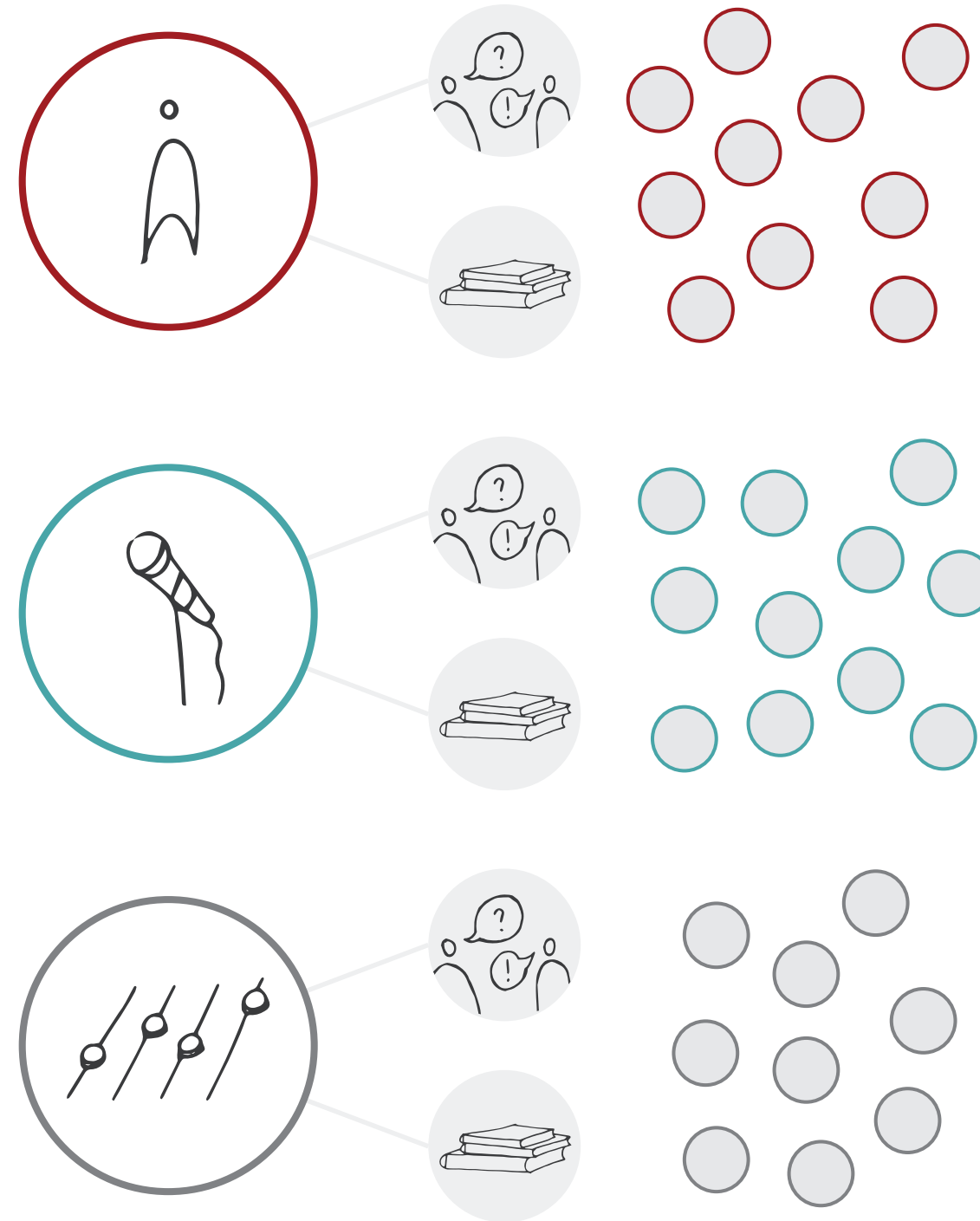

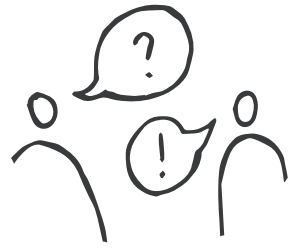

INTERVIEW - TORRE FLORIM

"connecting with the audience is essential"

"a performance in a unique place is one to remember"

"I like to be able to do something different on stage,
surprise the audience"

"smooth logistics is essential to enjoy the performance"

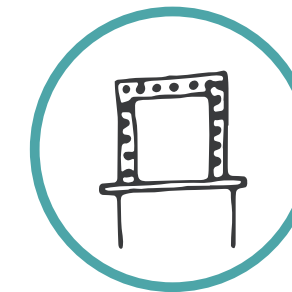
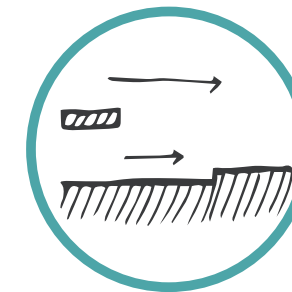
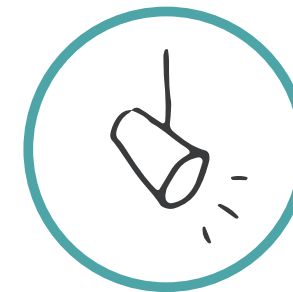
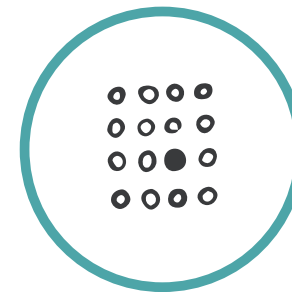
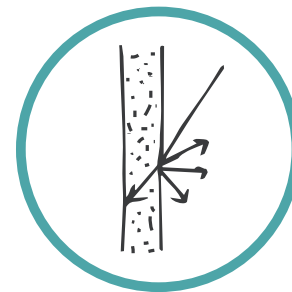
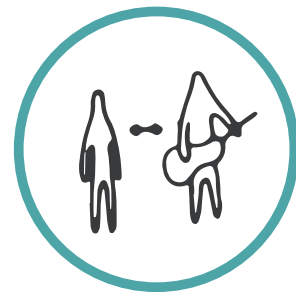

ANALYSIS

PART OF THE PERFORMANCE

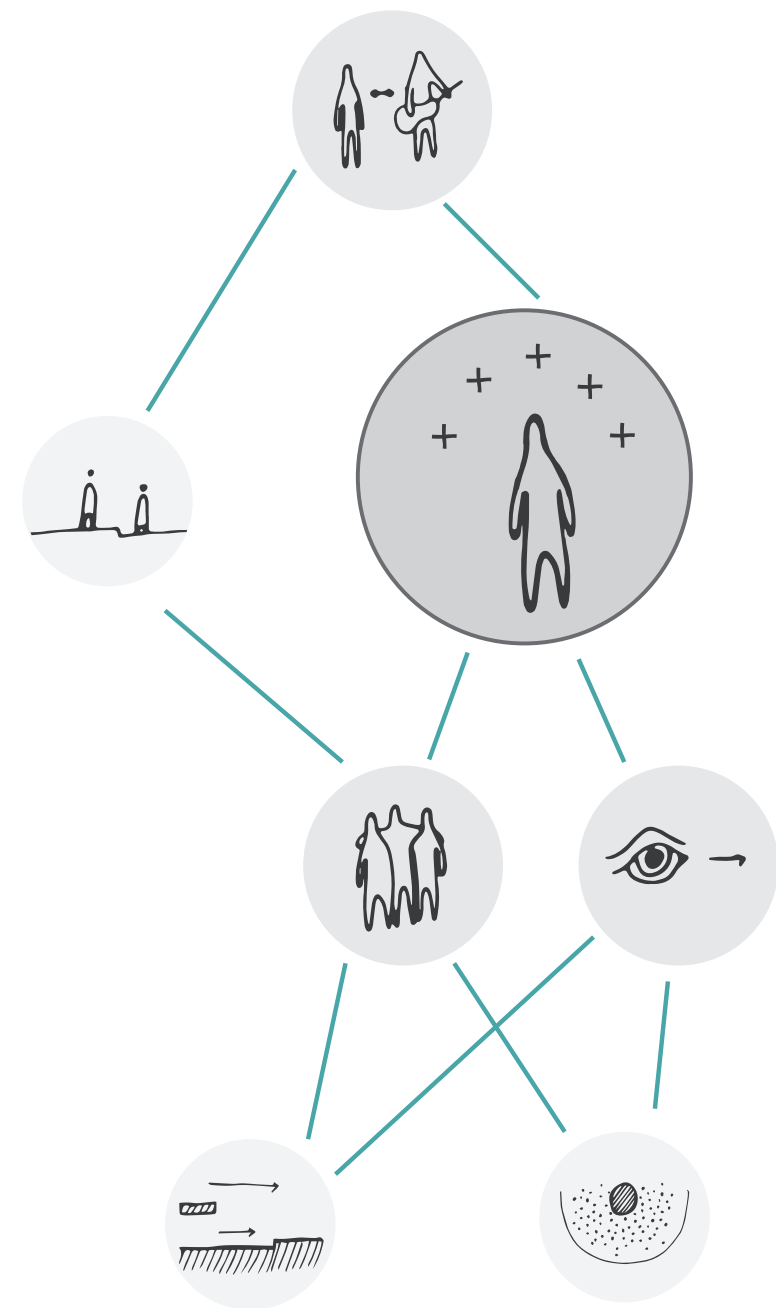

SOUND QUALITY

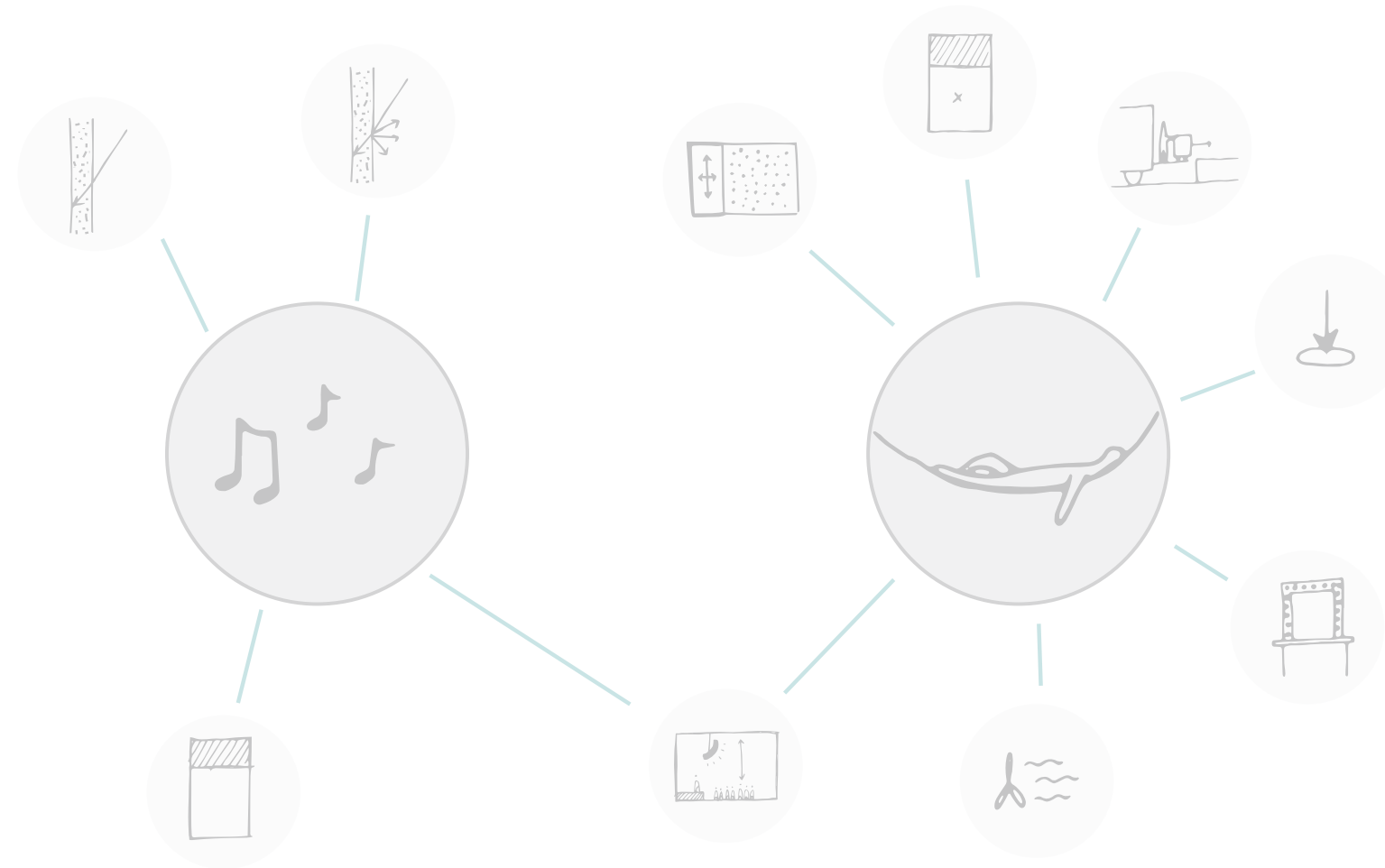

CAREFREE

UNIQUENESS

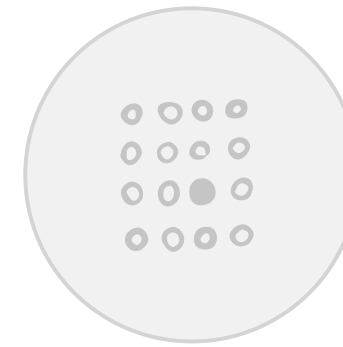

ANALYSIS

PART OF THE PERFORMANCE

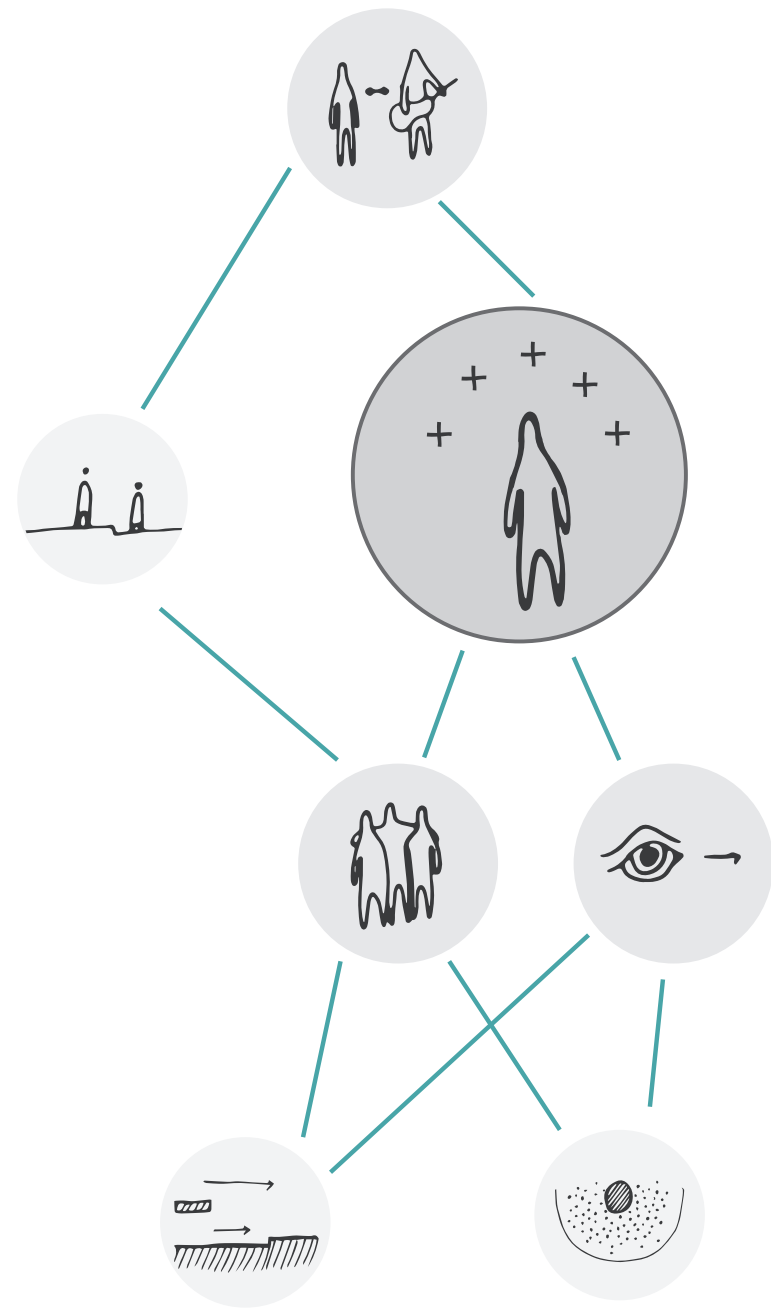

SOUND QUALITY

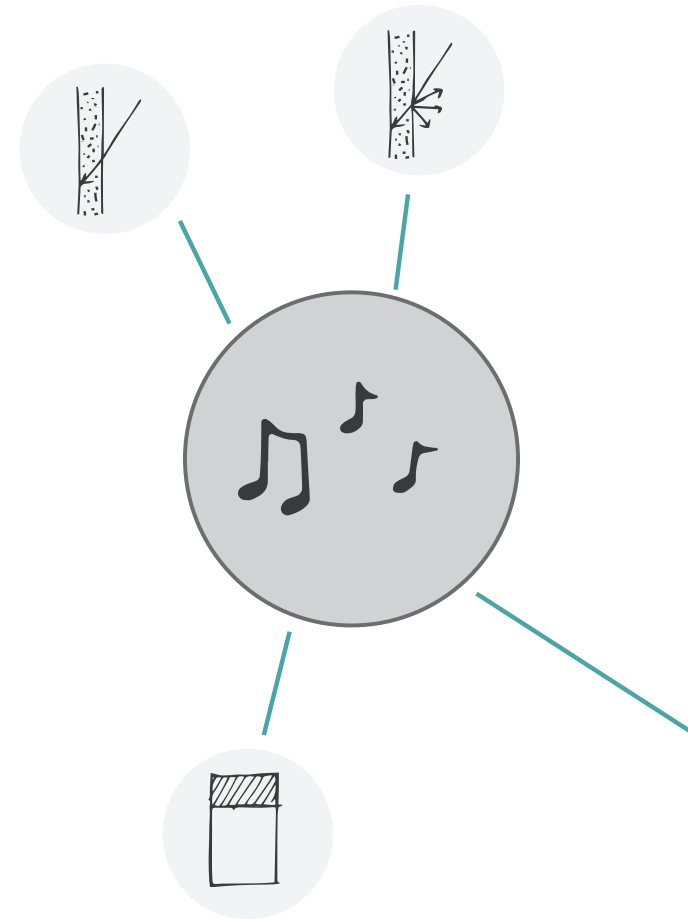

CAREFREE

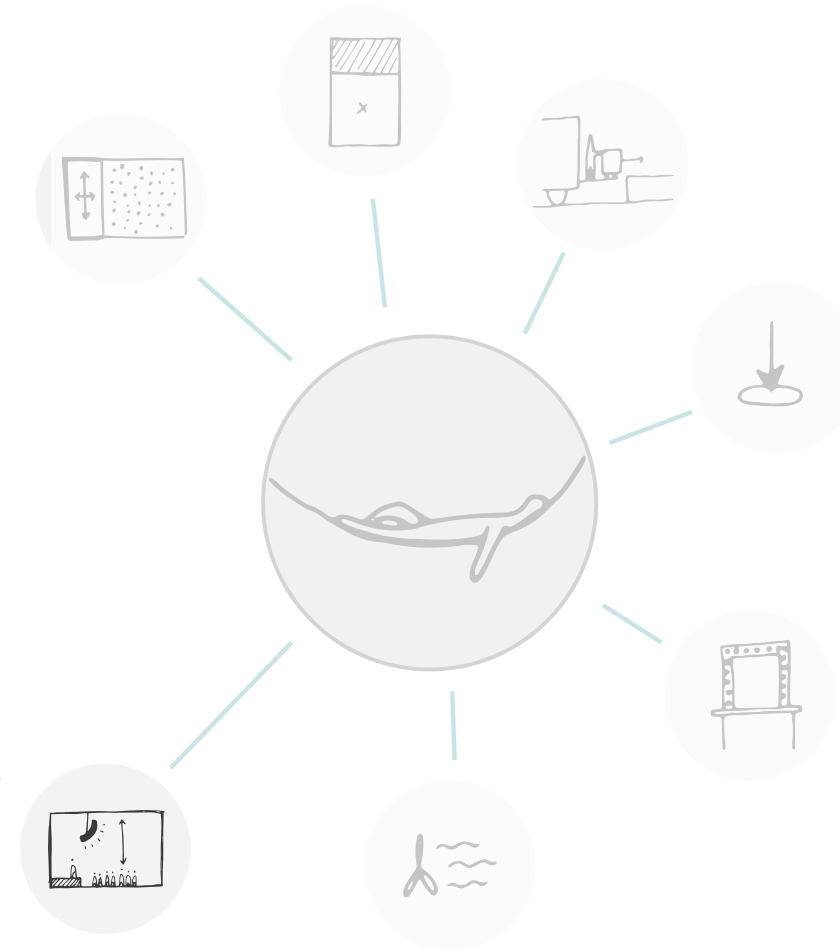

UNIQUENESS

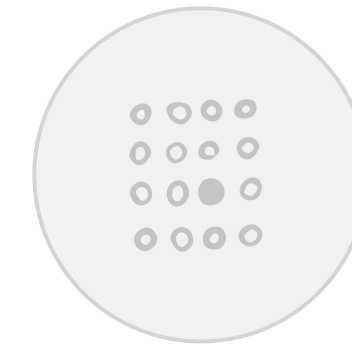

ANALYSIS

PART OF THE PERFORMANCE

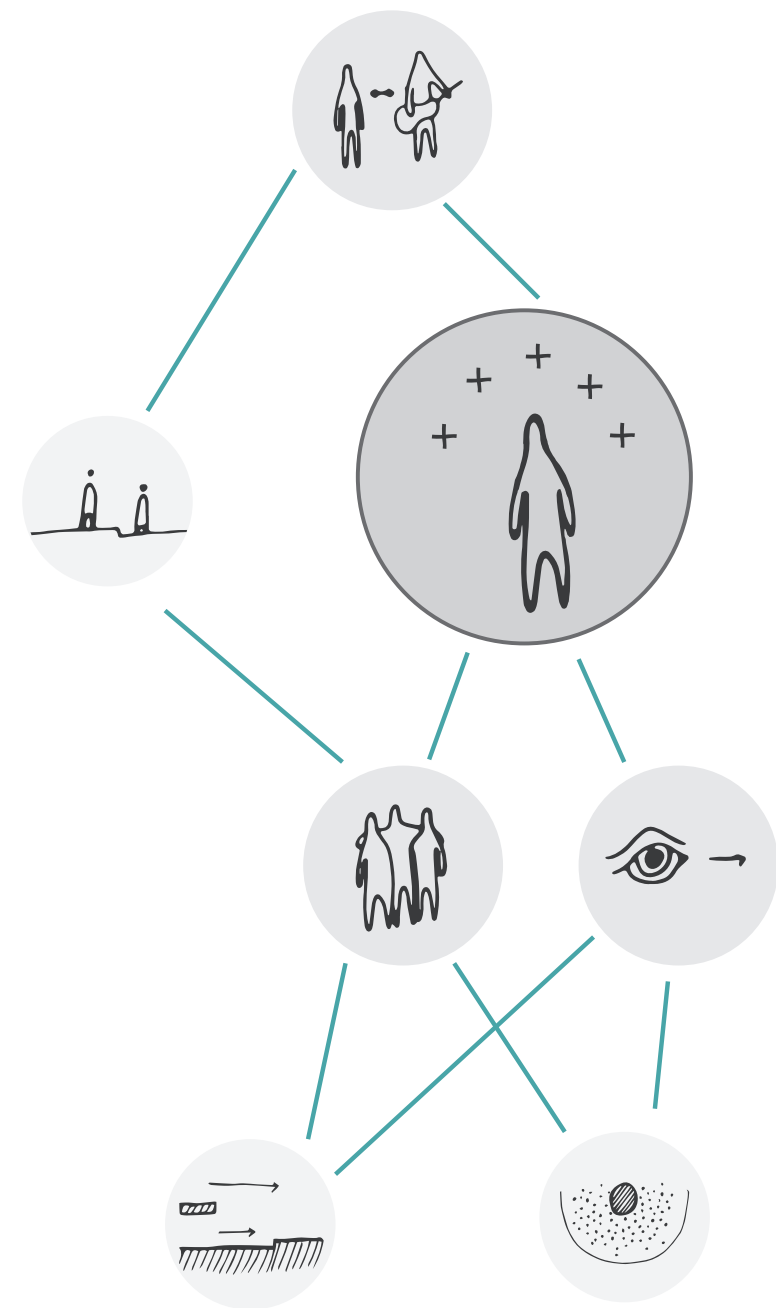

SOUND QUALITY

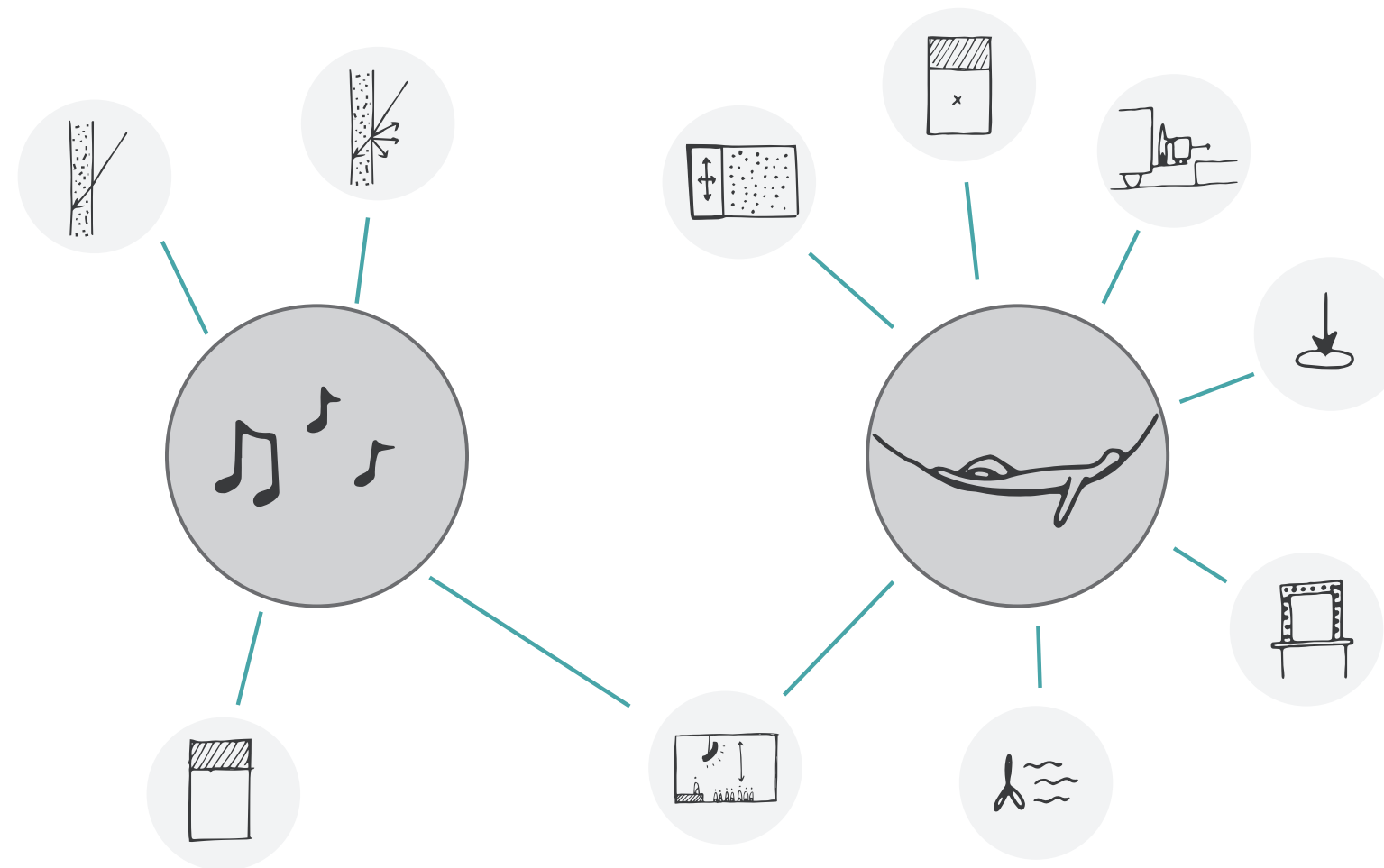

CAREFREE

UNIQUENESS

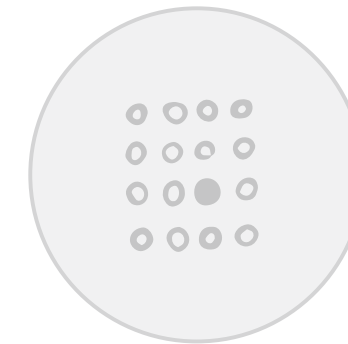

ANALYSIS

PART OF THE PERFORMANCE

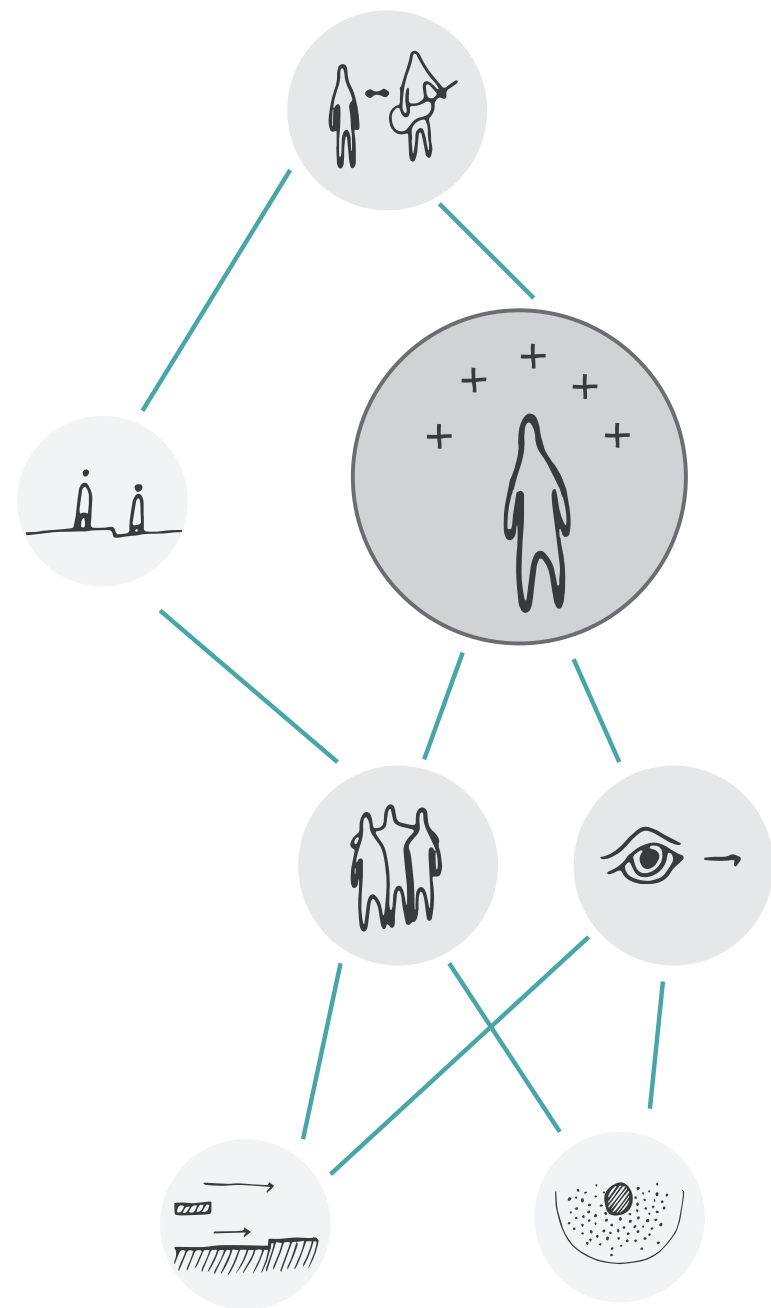

SOUND QUALITY

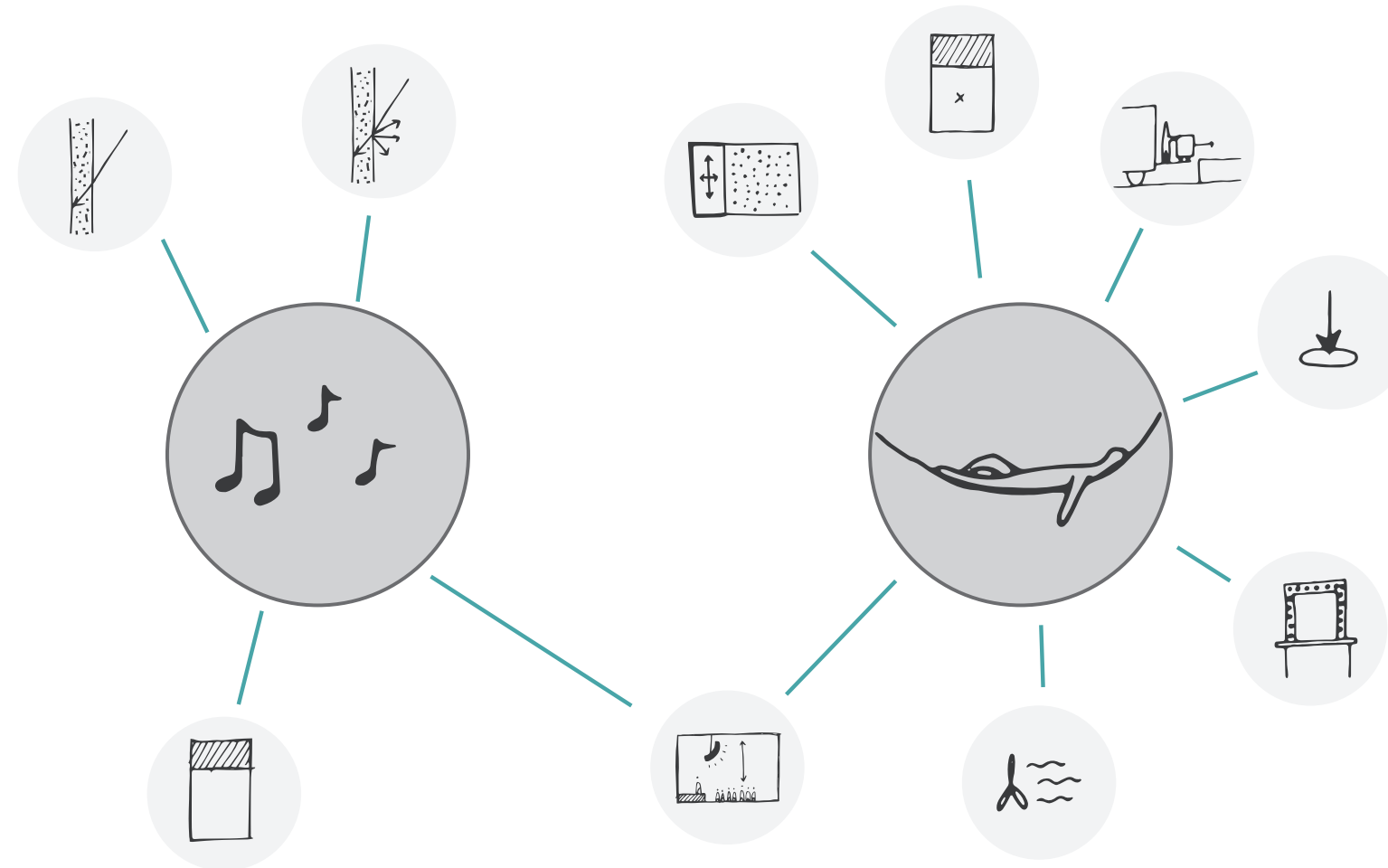

CAREFREE

UNIQUENESS

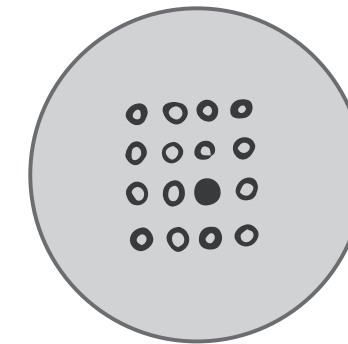

CONCLUSION

What aspects of a performance place contribute to the experience of the performance at a pop music festival?



PART OF THE PERFORMANCE



SOUND QUALITY

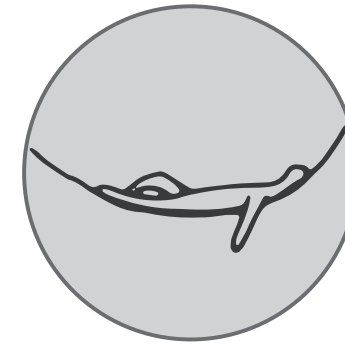

CAREFREE

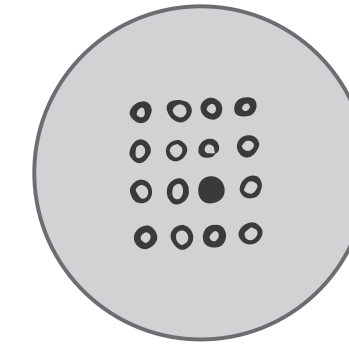

UNIQUENESS

FROM RESEARCH TO DESIGN

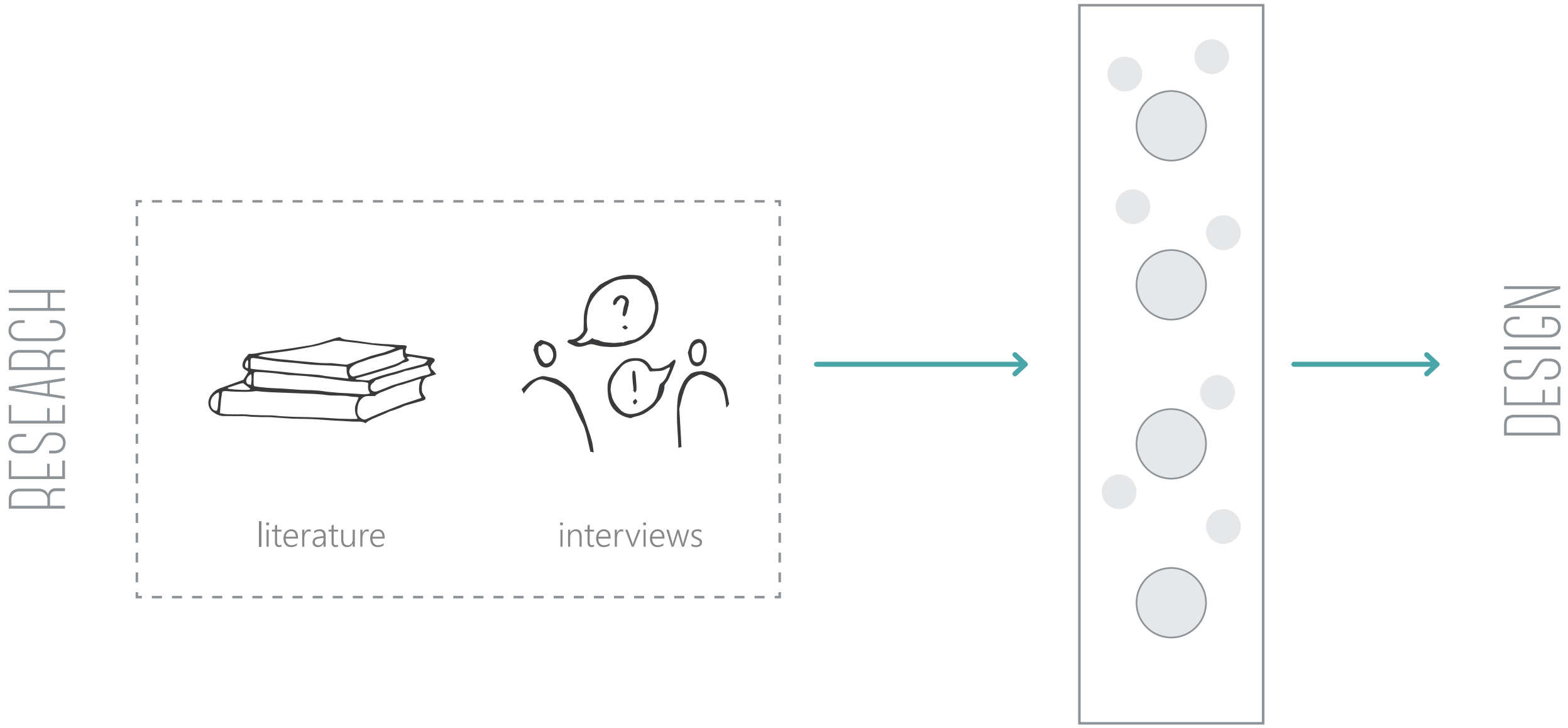

FROM RESEARCH TO DESIGN

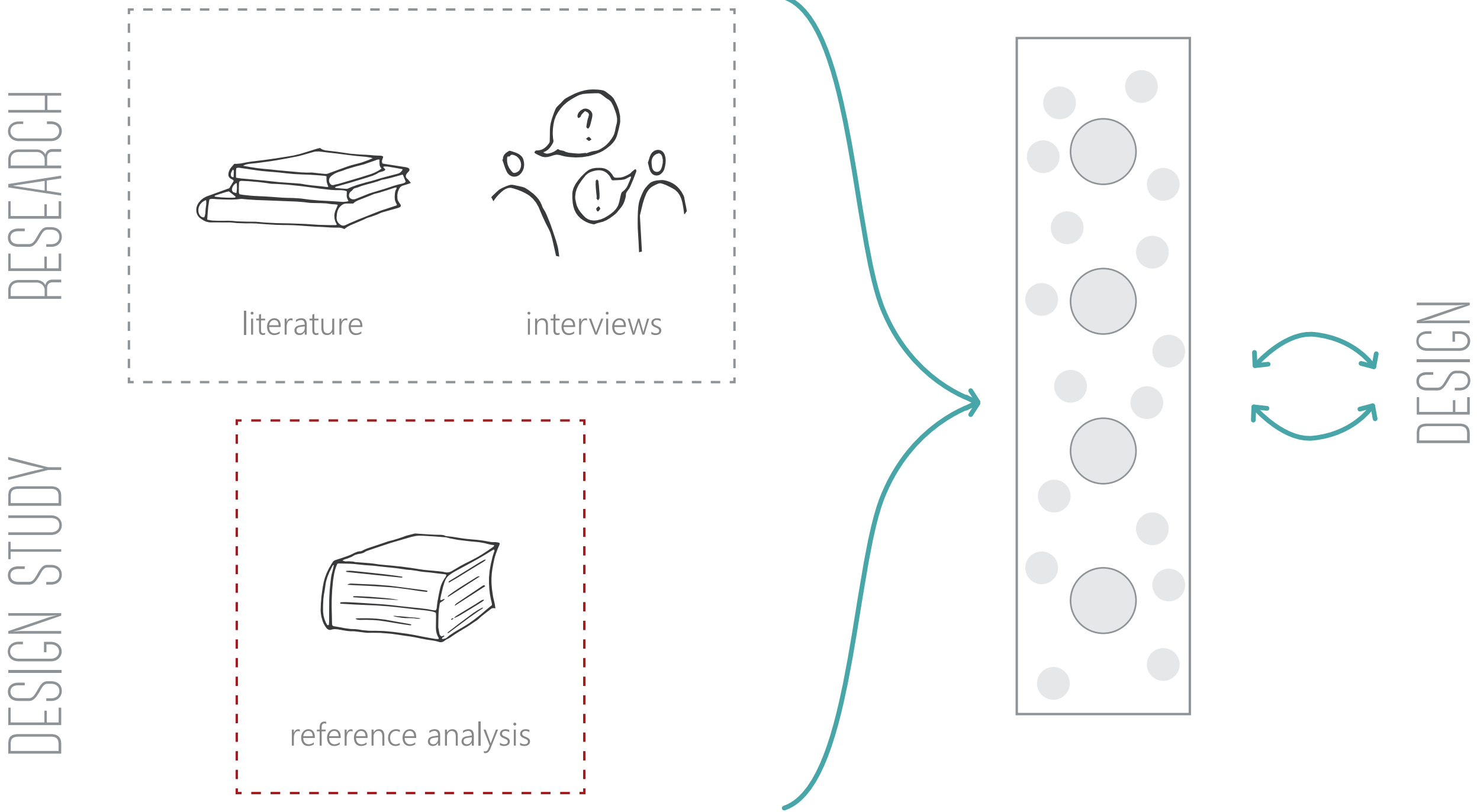

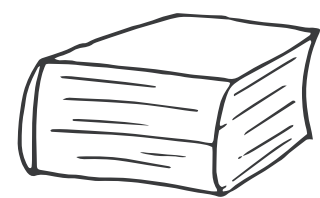

REFERENCE ANALYSIS

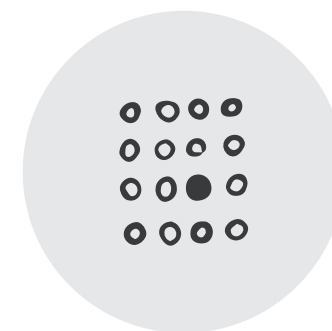

Pop concert halls



Festival architecture



Temporary and cultural

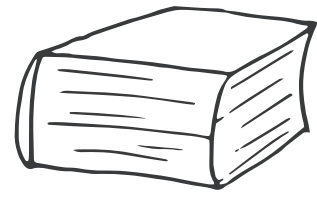

REFERENCE EXAMPLE - PARADISO

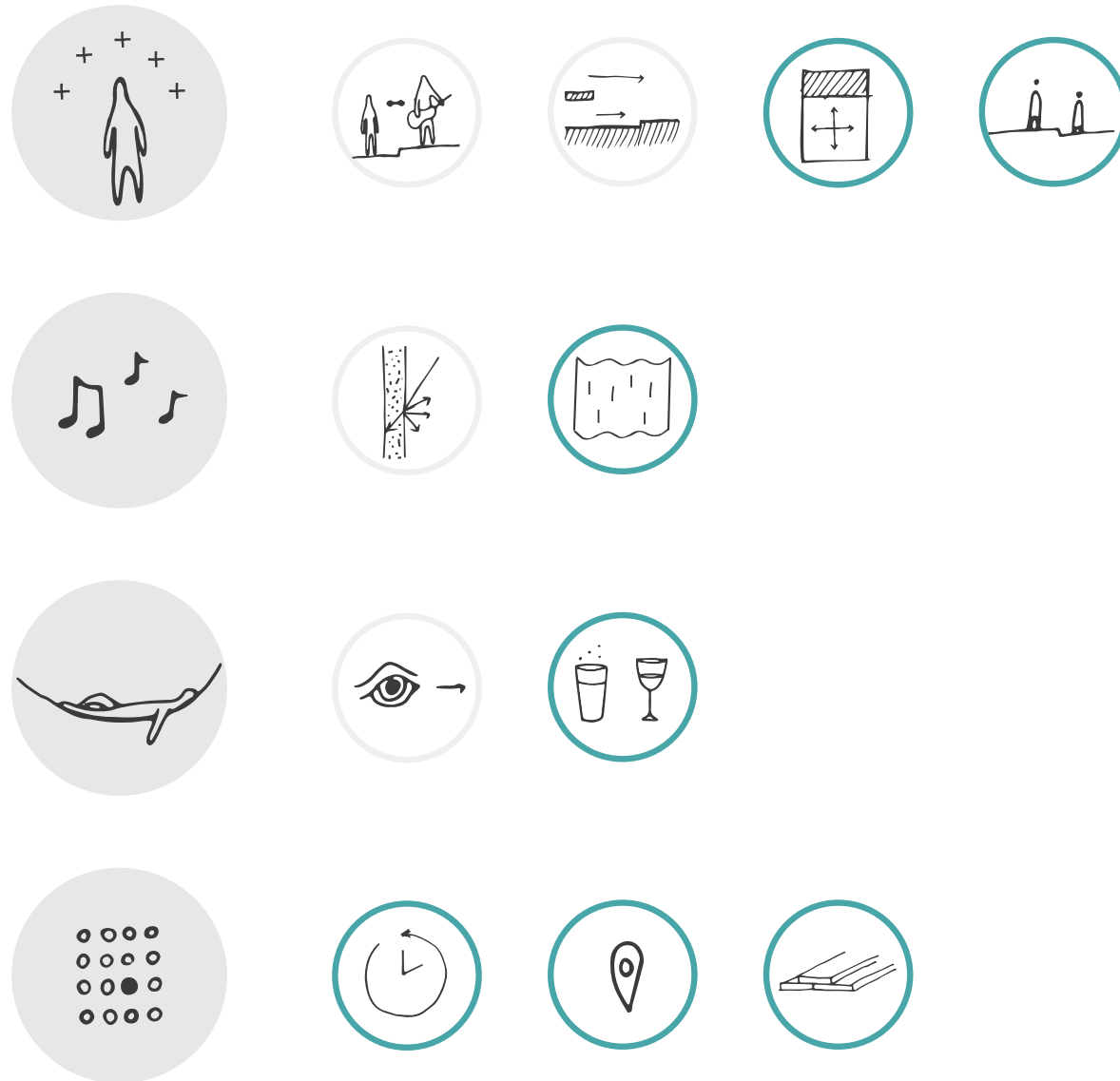

Source: residentadvisor.net

ASPECTS - RESEARCH

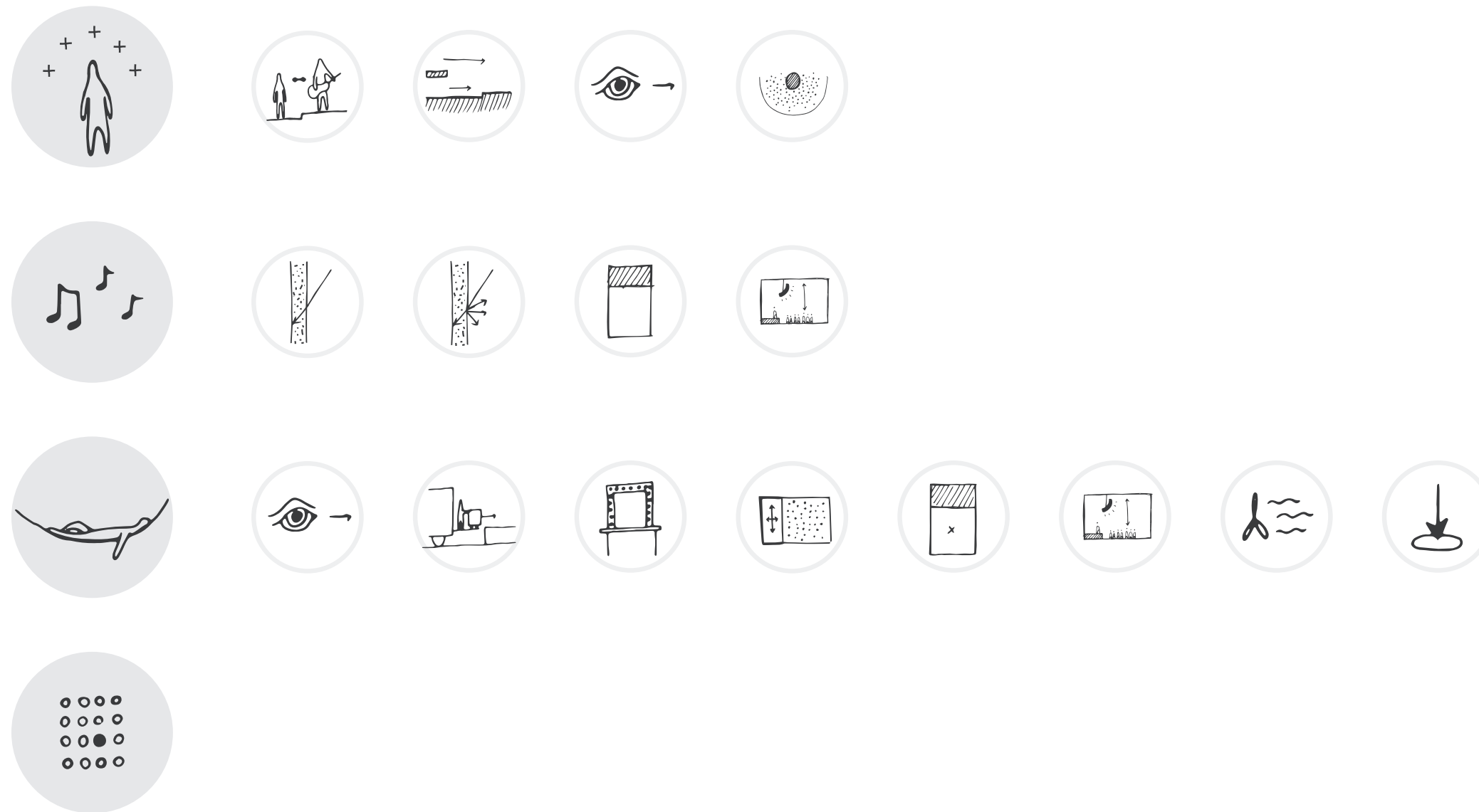

ASPECTS - REFERENCE ANALYSIS

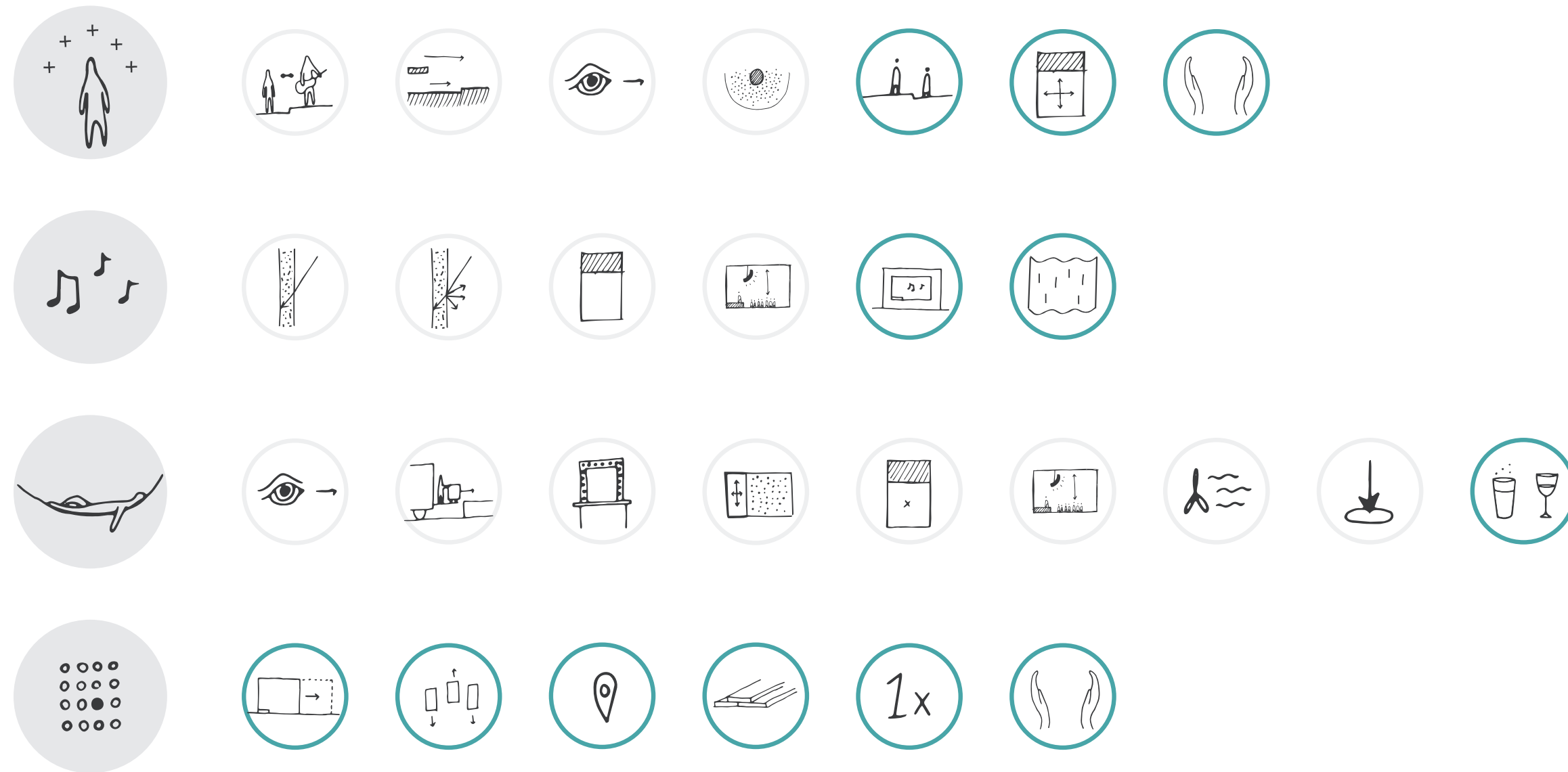

DESIGN



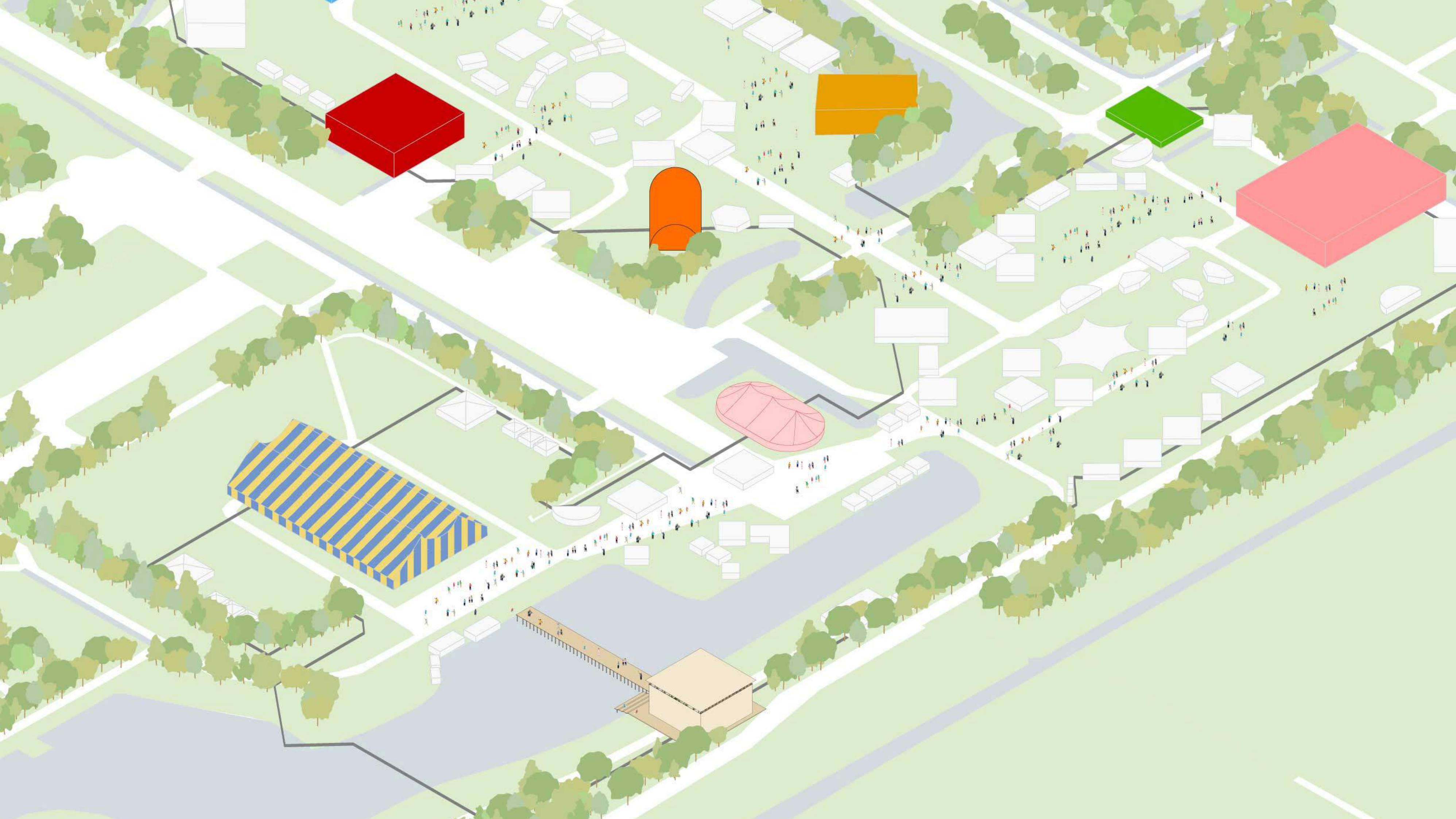

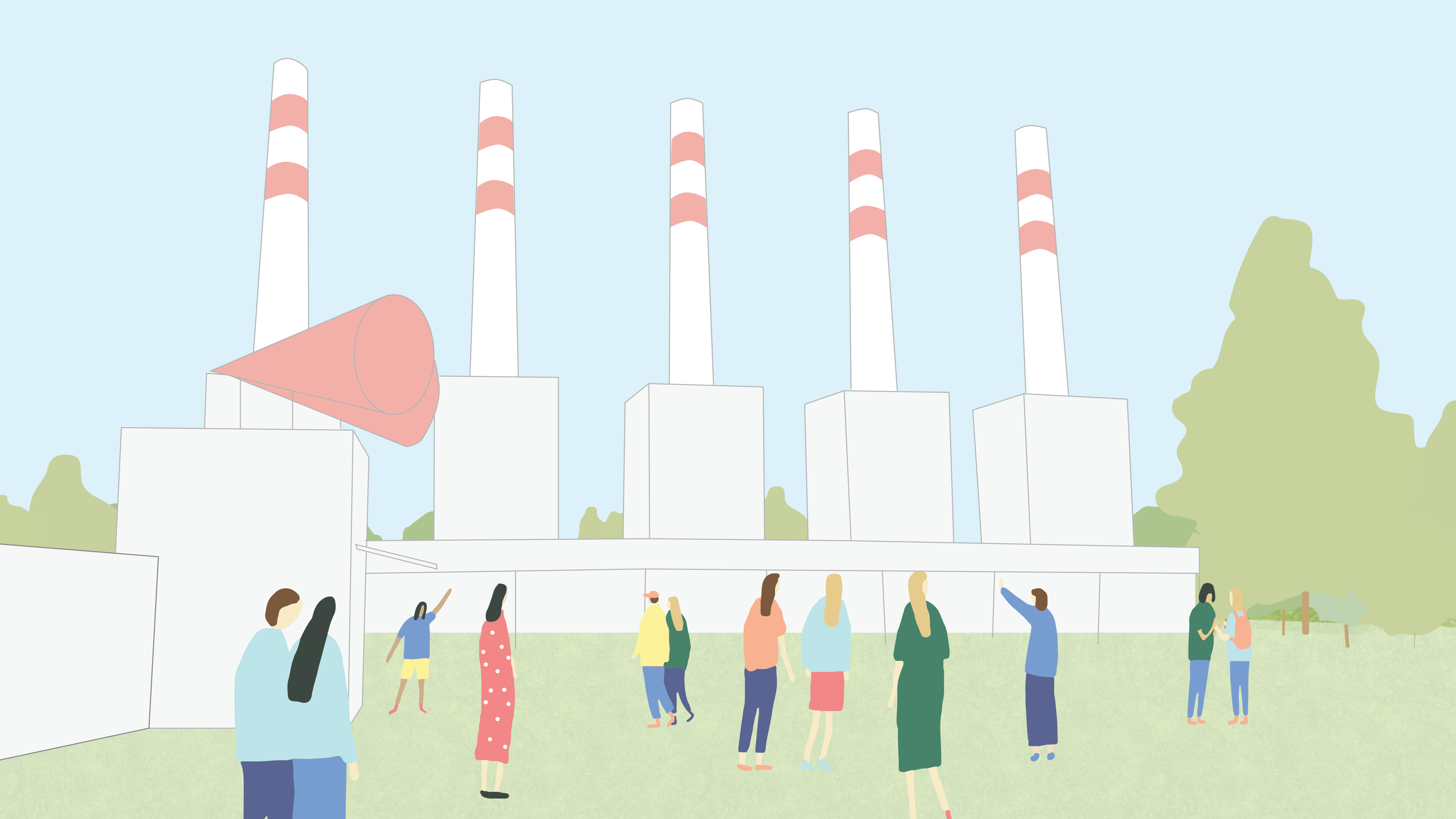











BAR

HALL



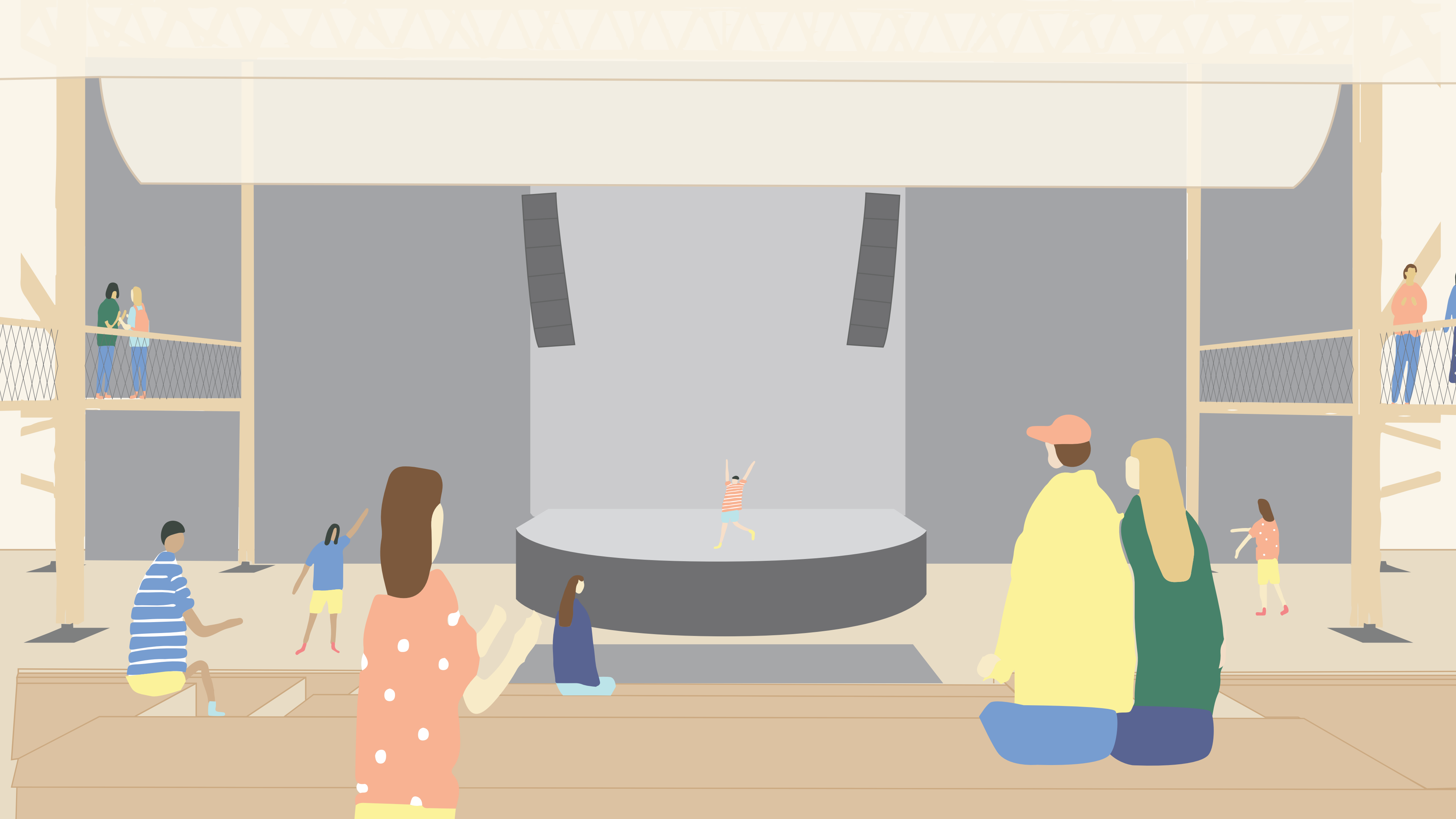

FORM

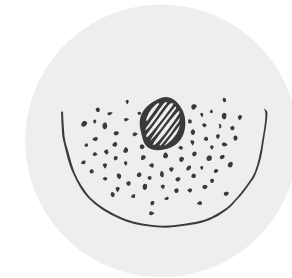
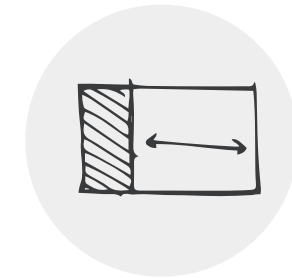
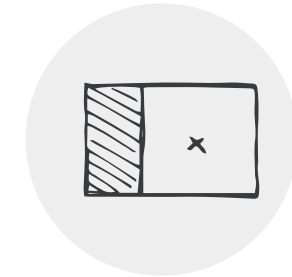
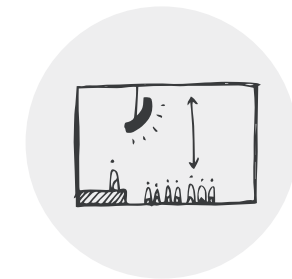
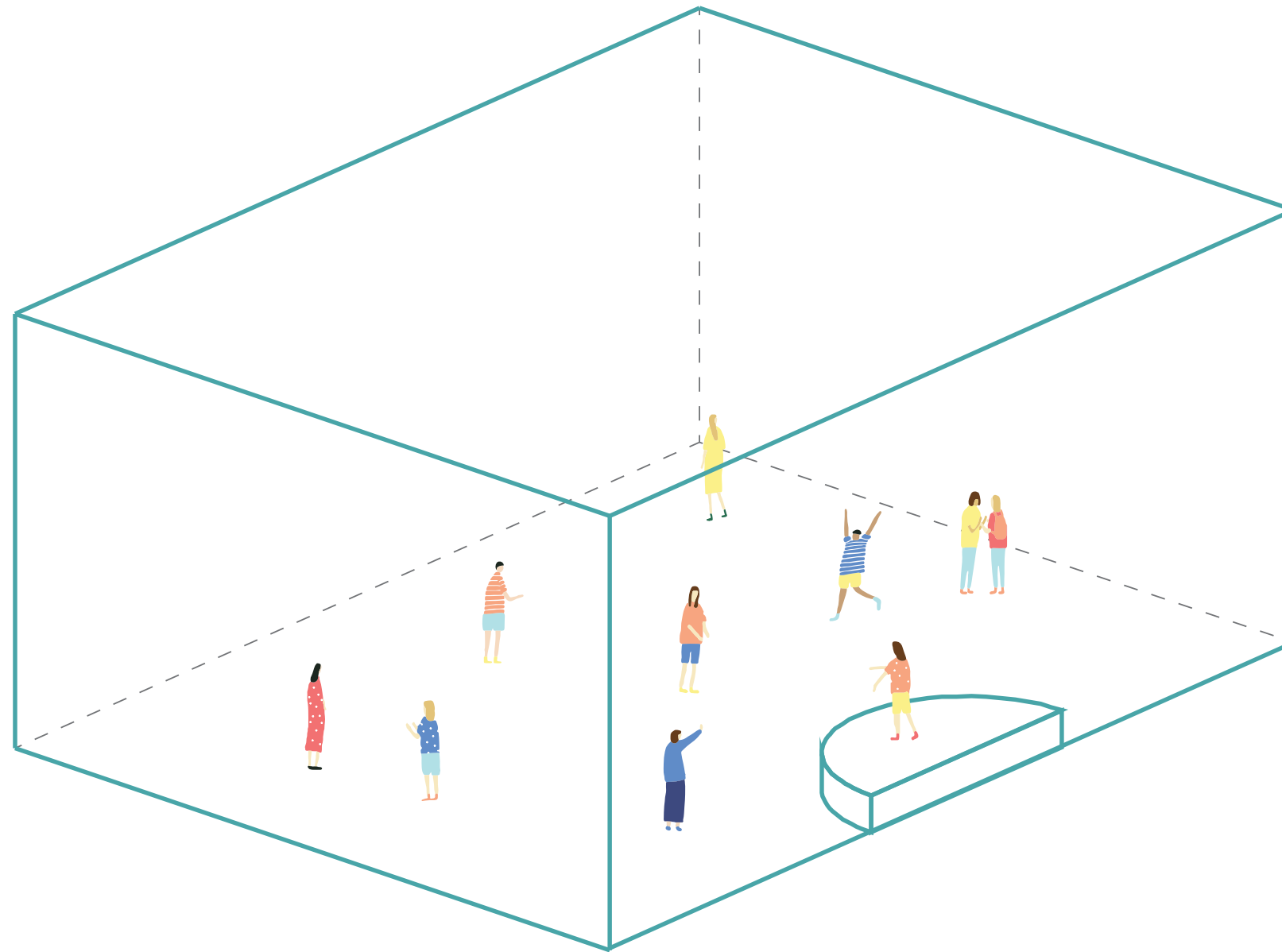

SIGHT-LINES

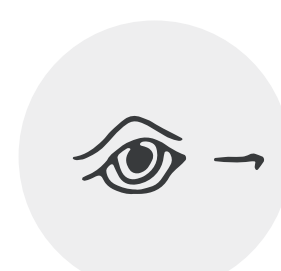
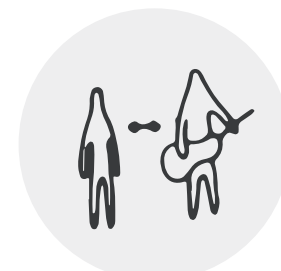
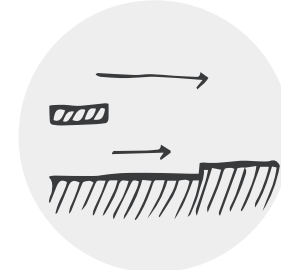
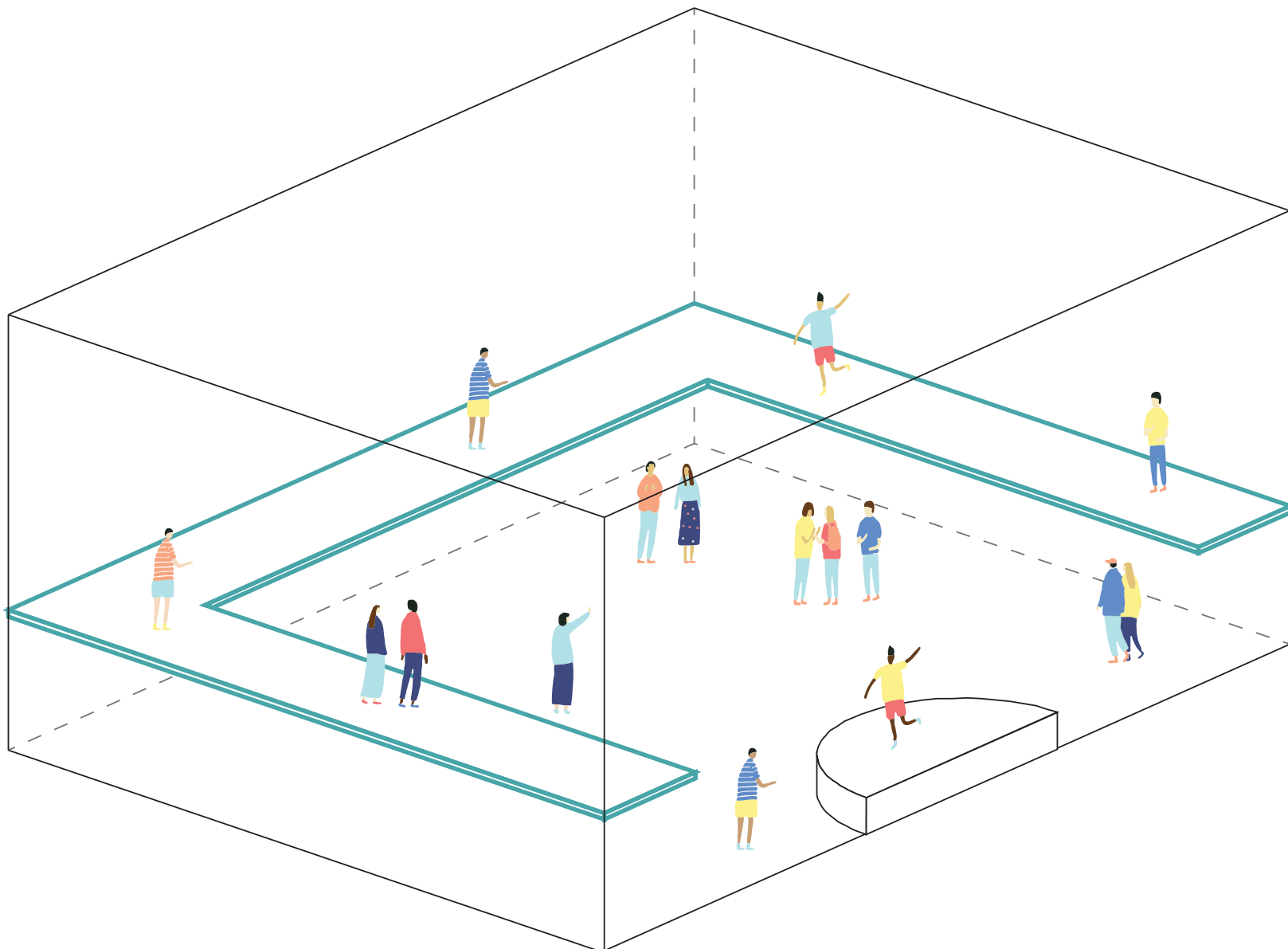

SEATING

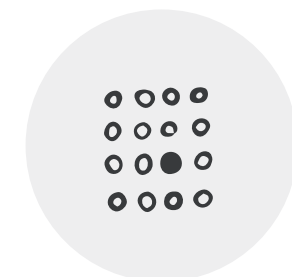
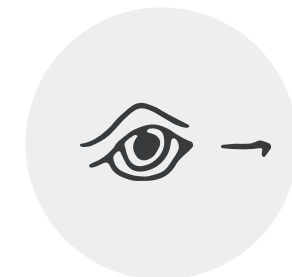
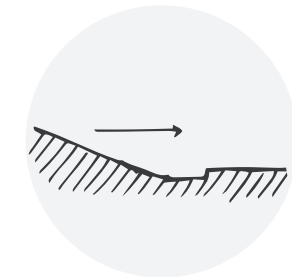
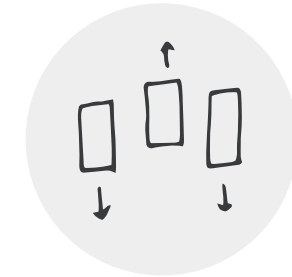
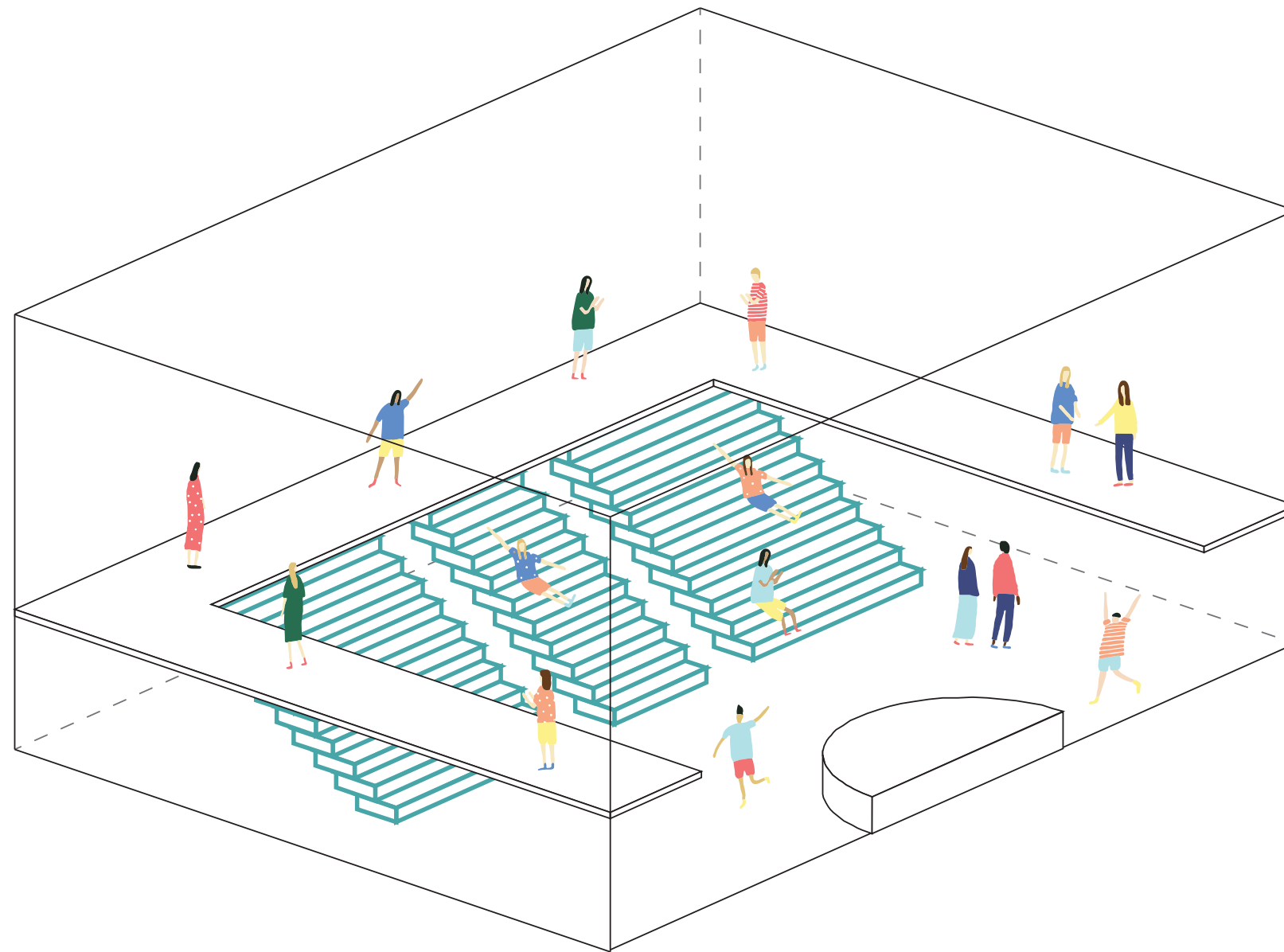

SEATING

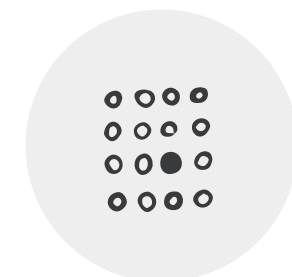
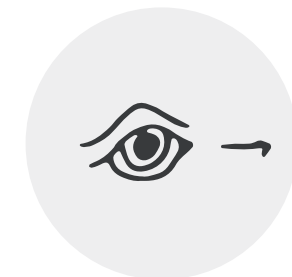
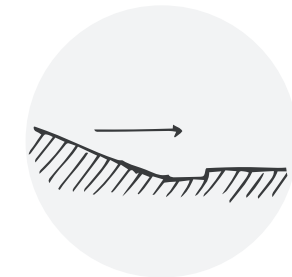
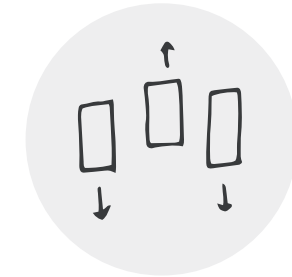
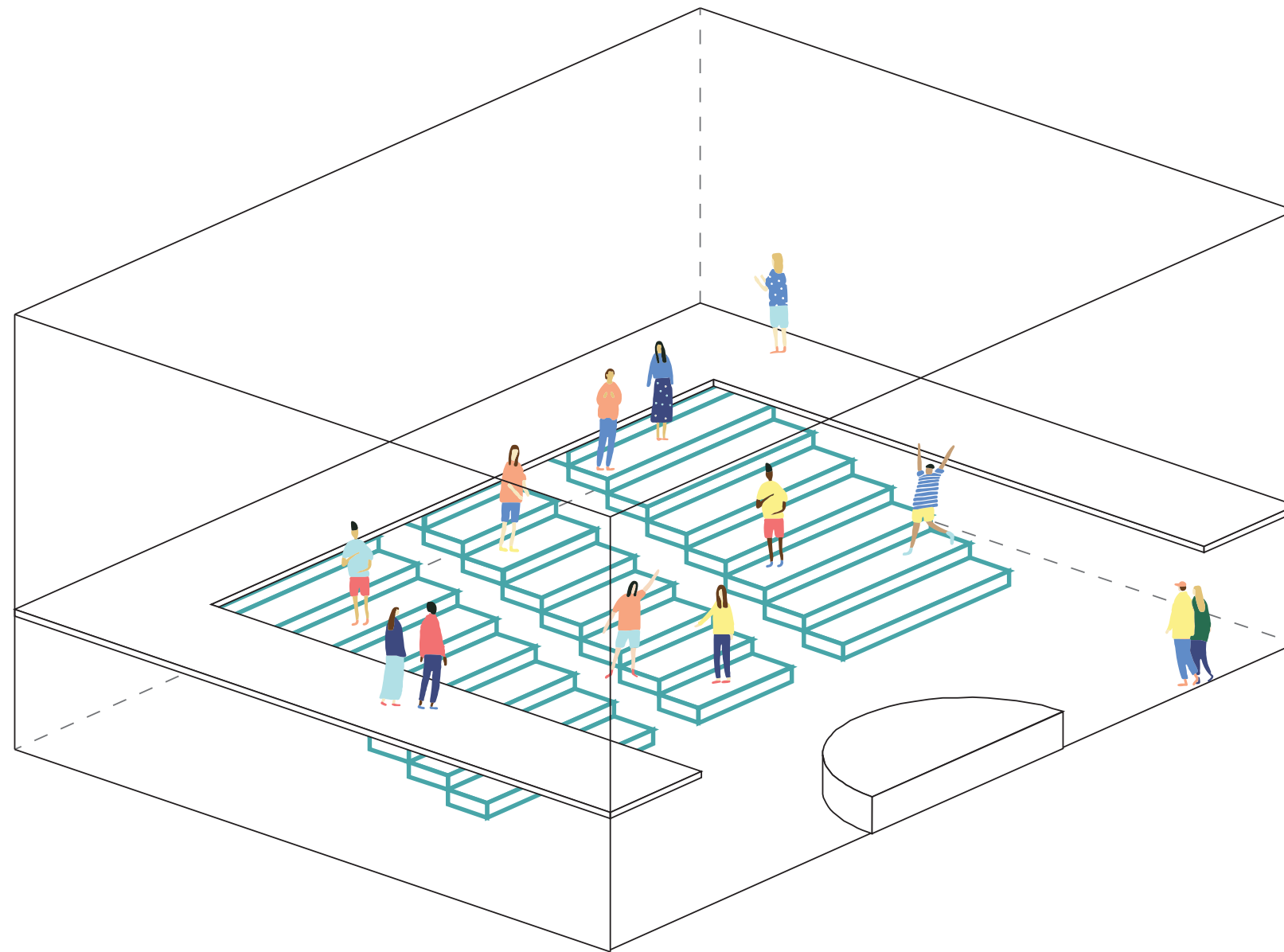

SEATING

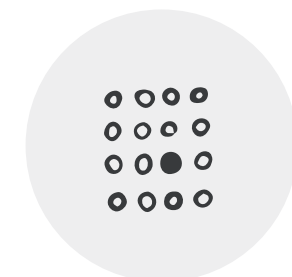
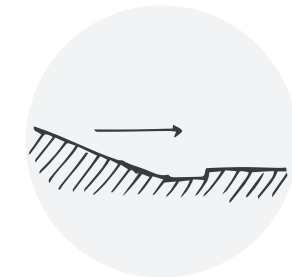
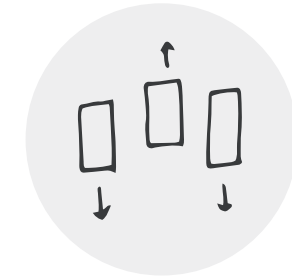
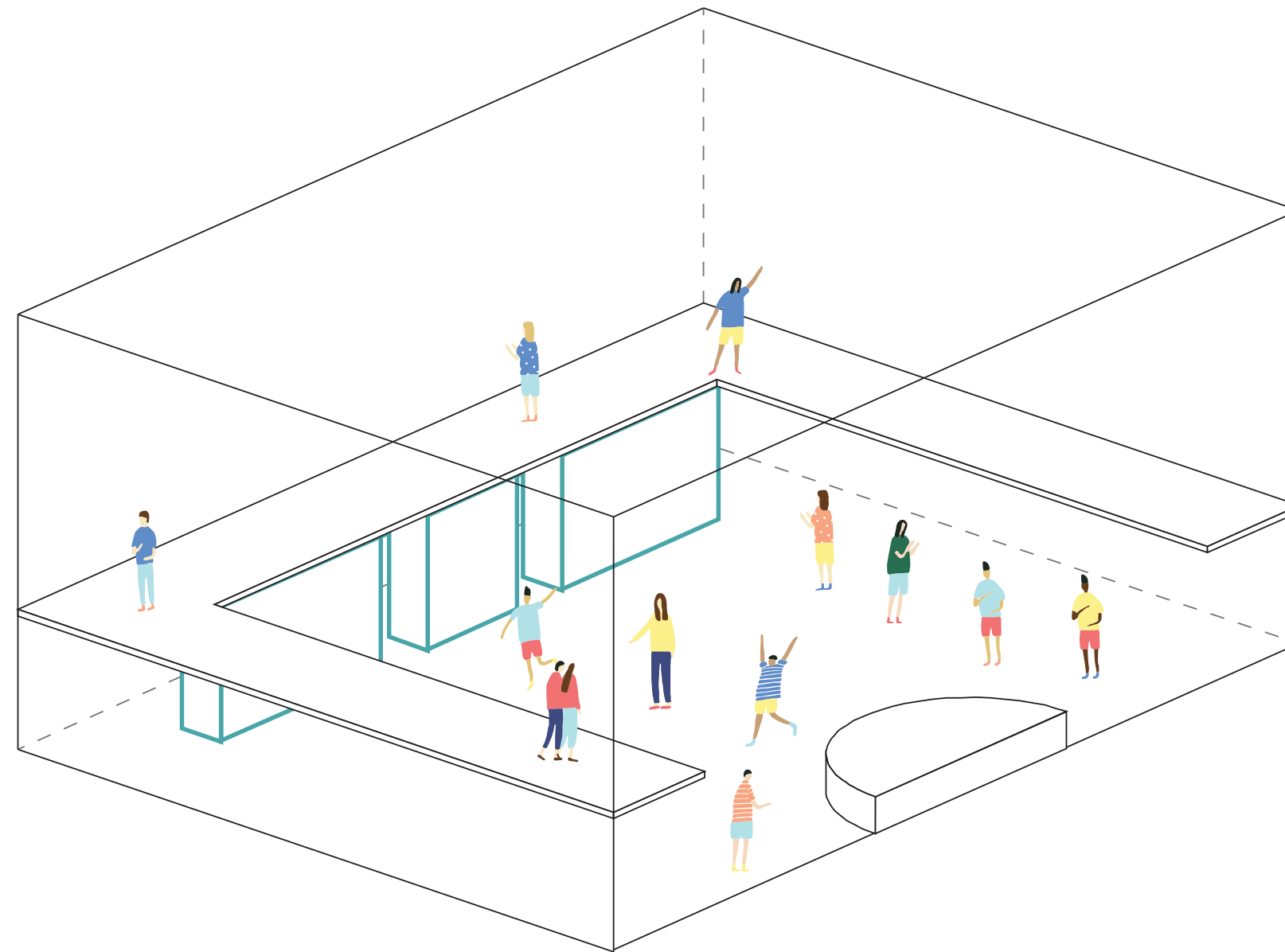

BACK STAGE

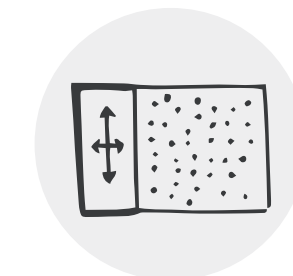
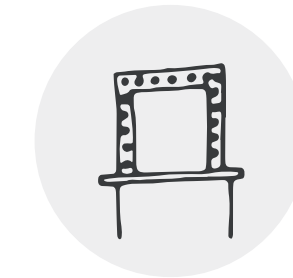
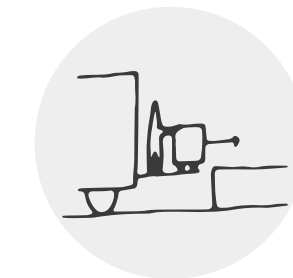
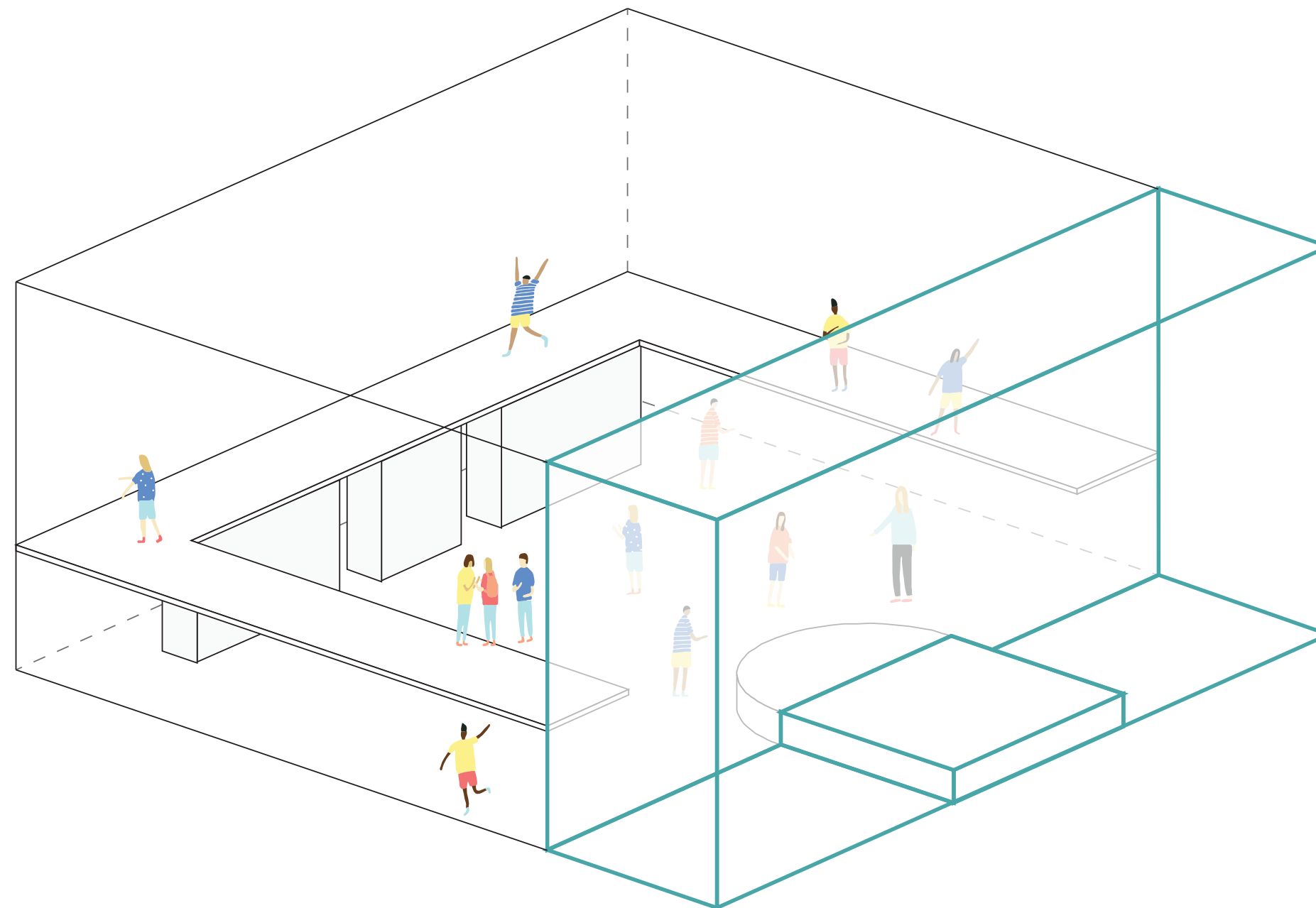

FLEXIBLE CEILING

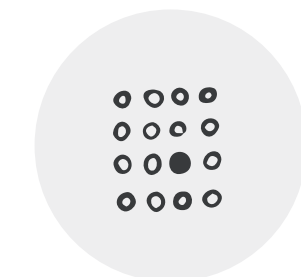
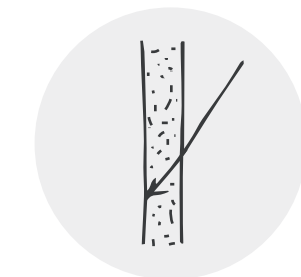
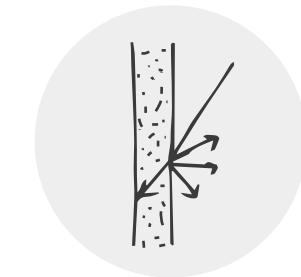
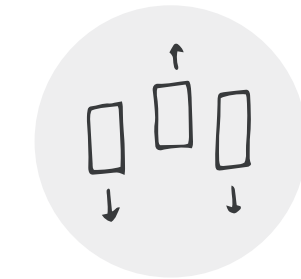
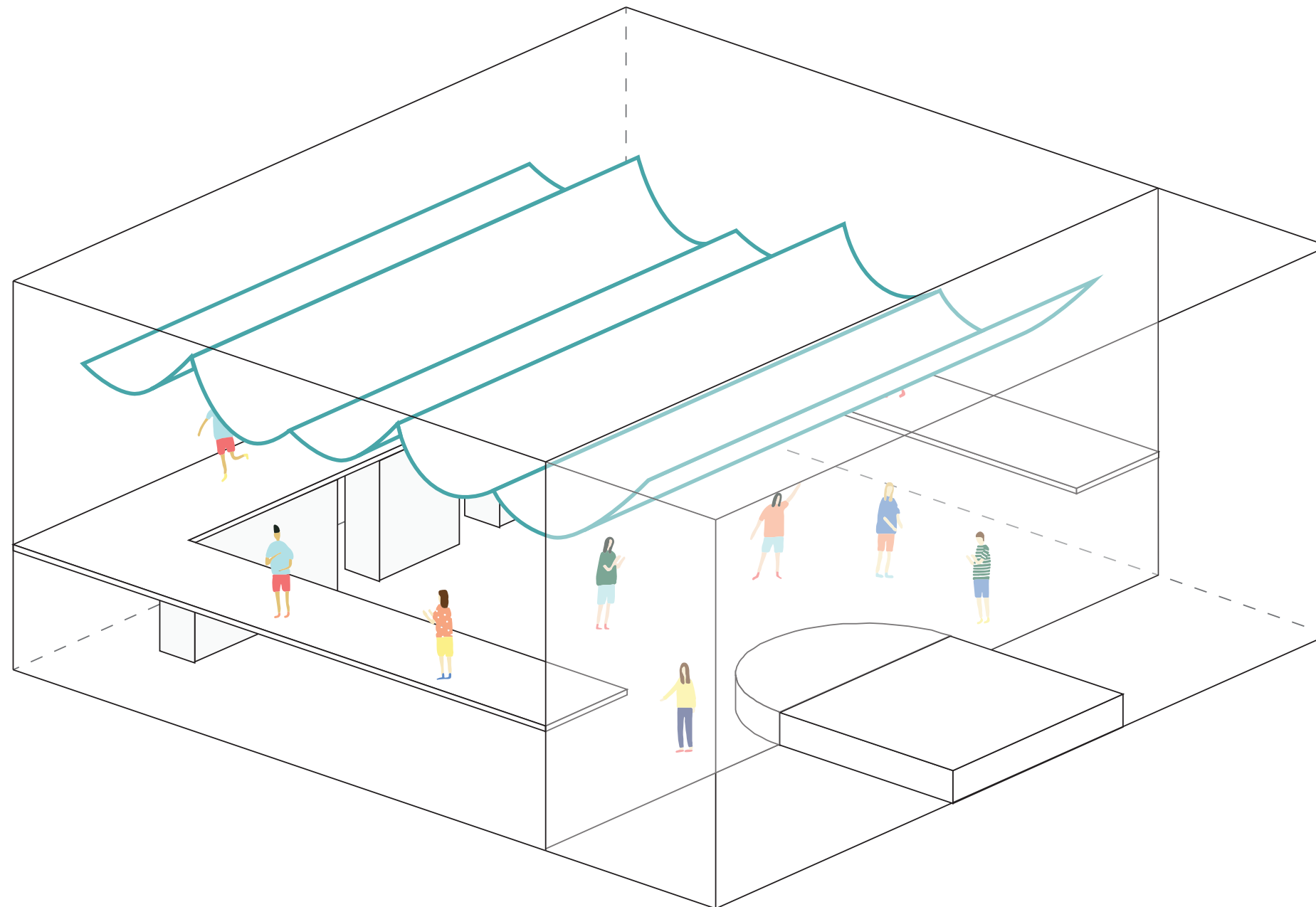

FLEXIBLE CEILING

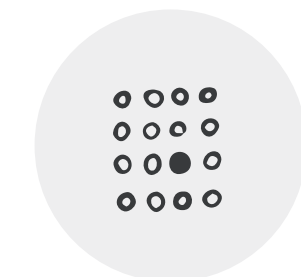
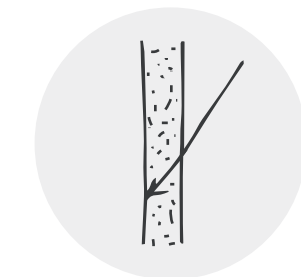
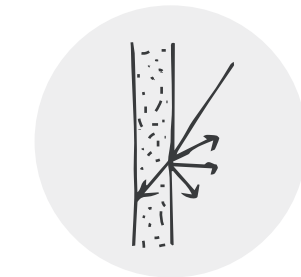
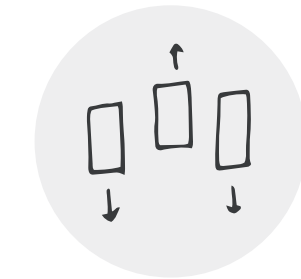
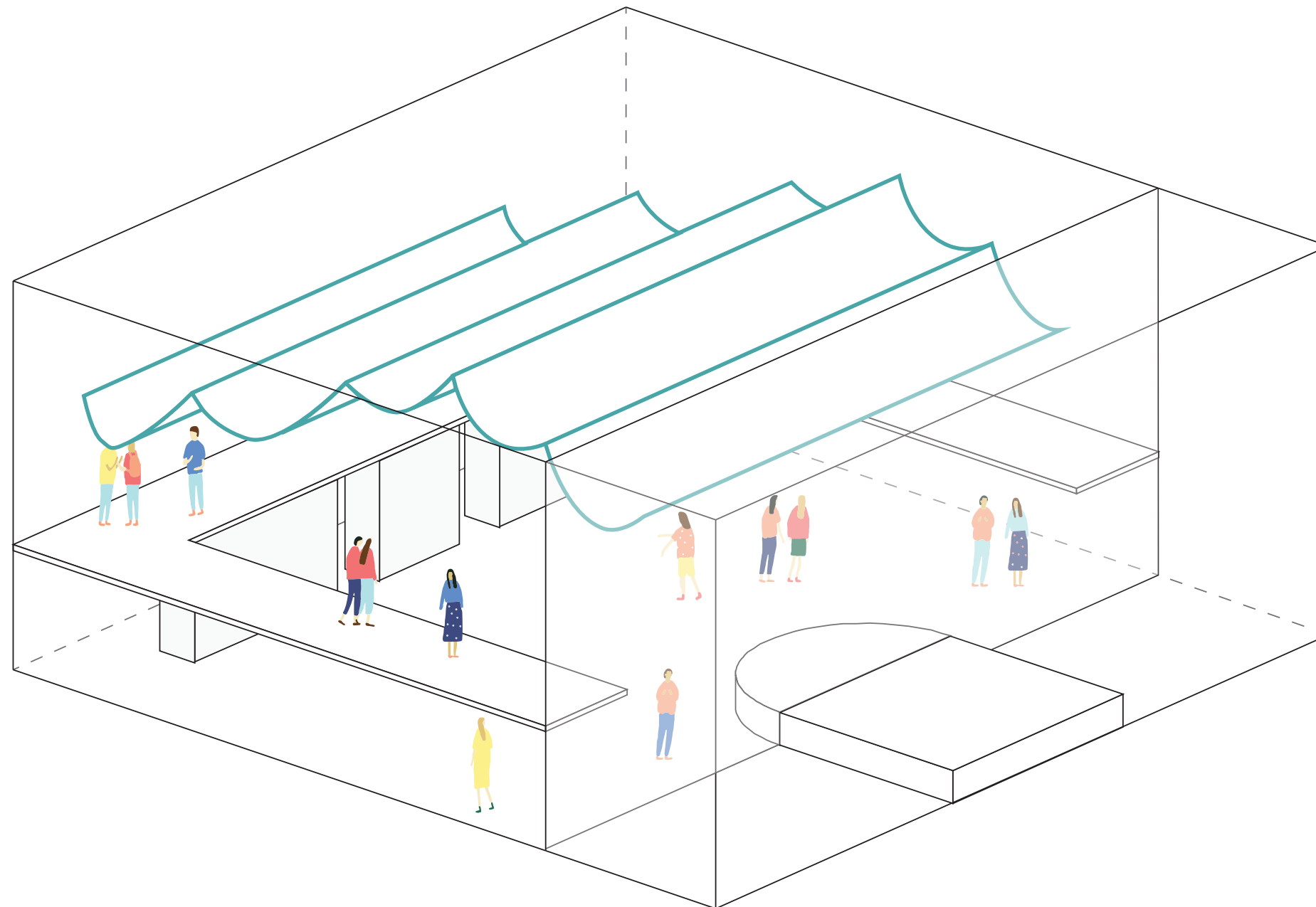

SECTION

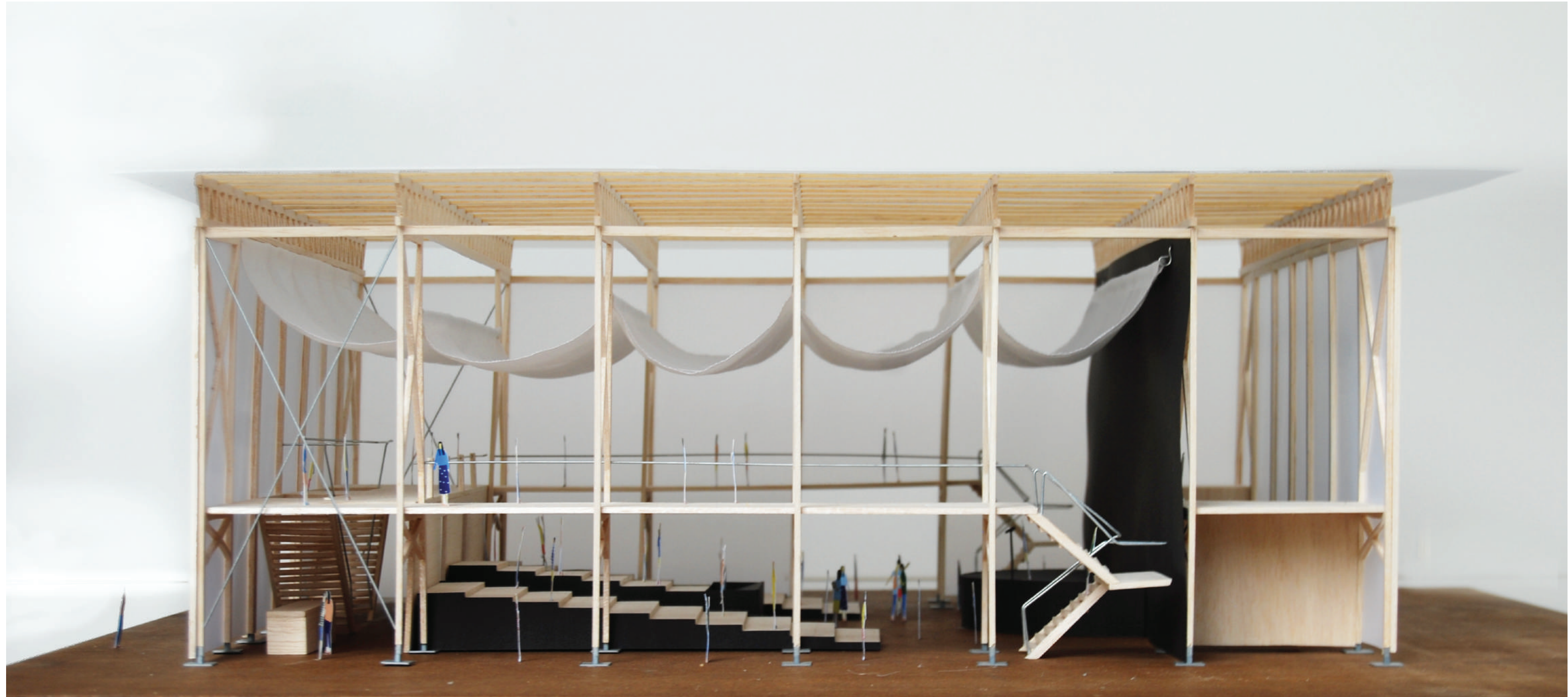

ACOUSTIC CONCEPT

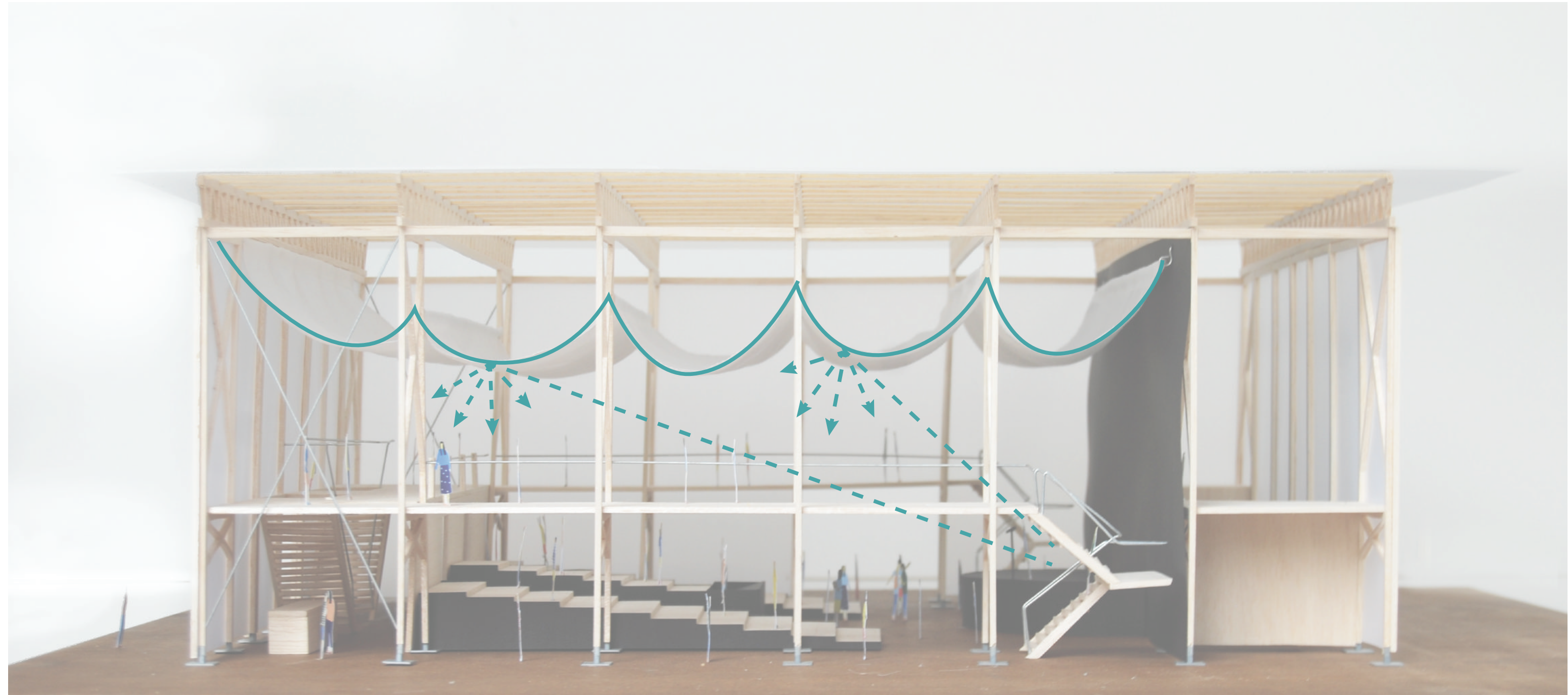

ACOUSTIC CONCEPT



ACOUSTIC CONCEPT

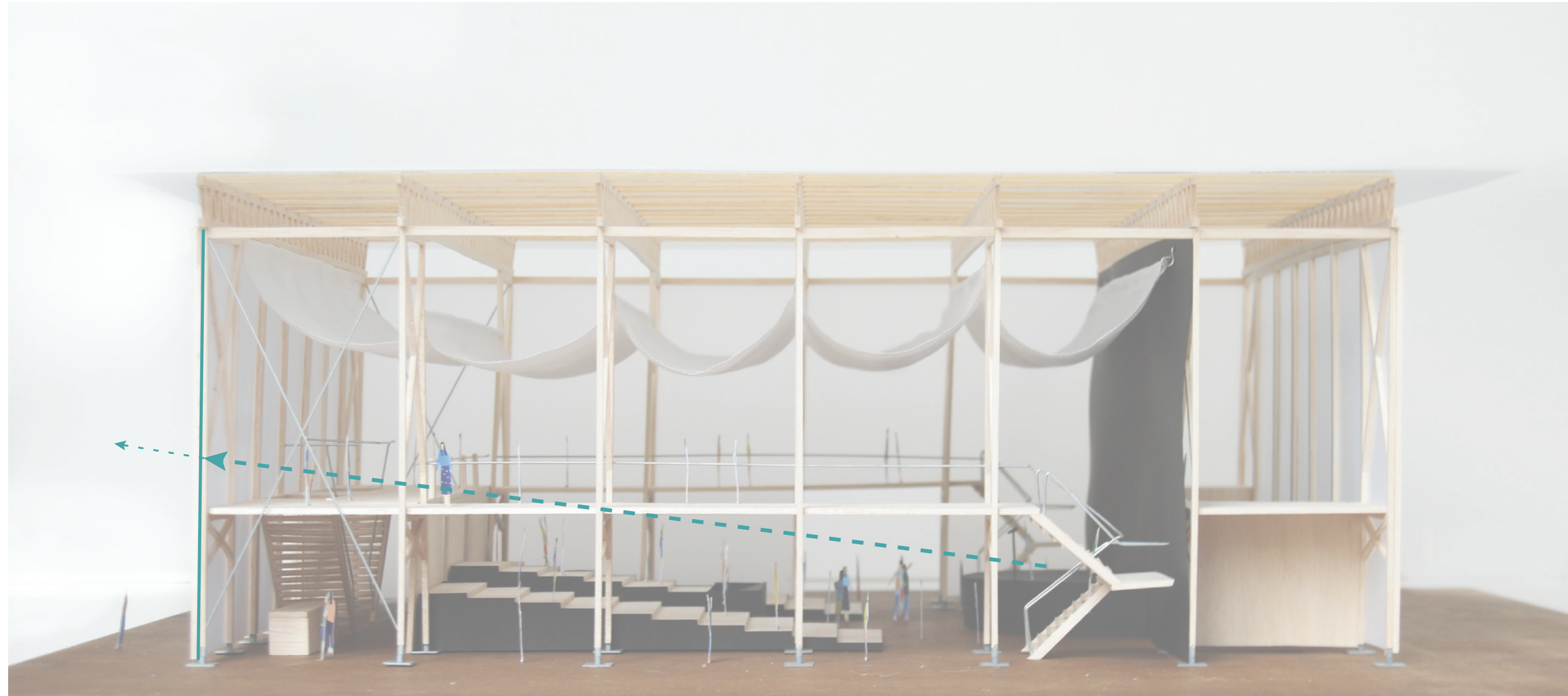

ACOUSTIC CONCEPT

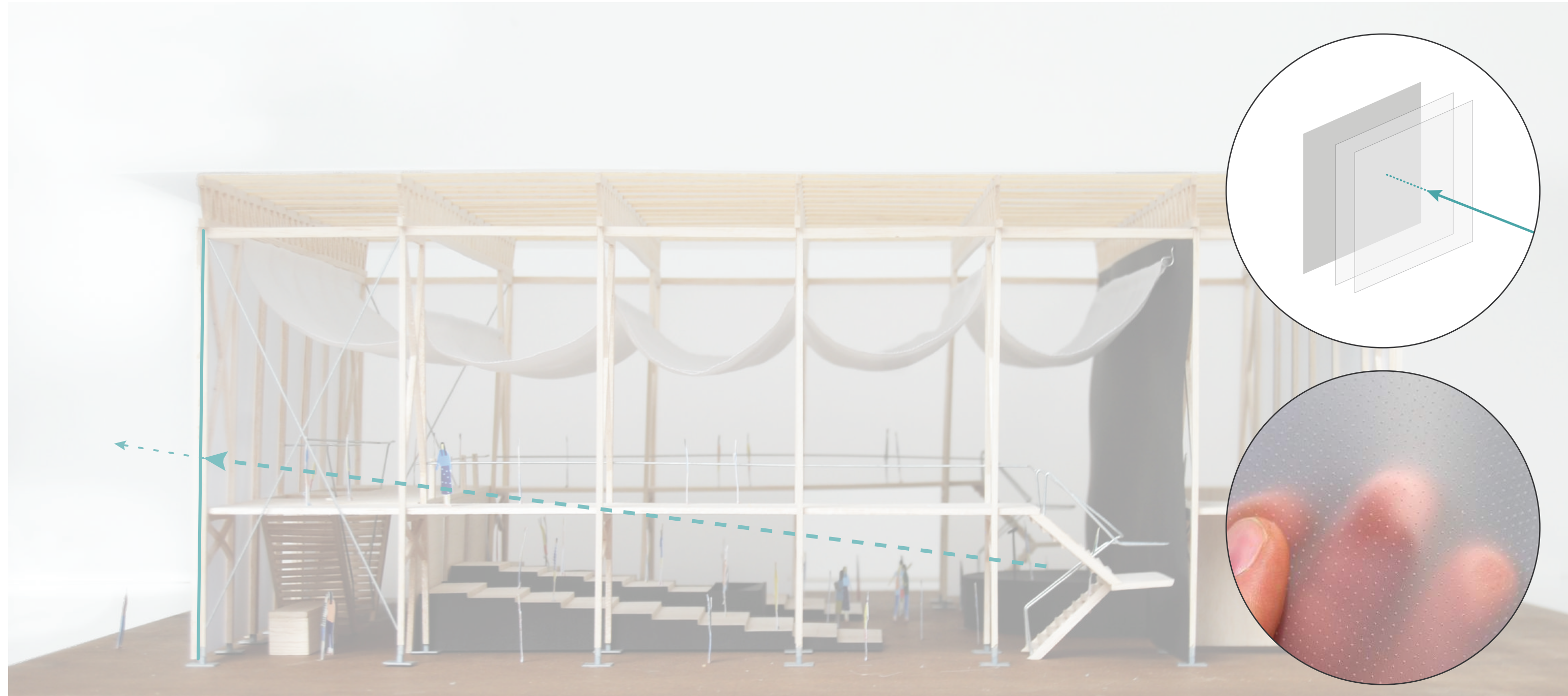

Source: Barissol - Microsorber

ACOUSTIC CONCEPT

micro perforated facade

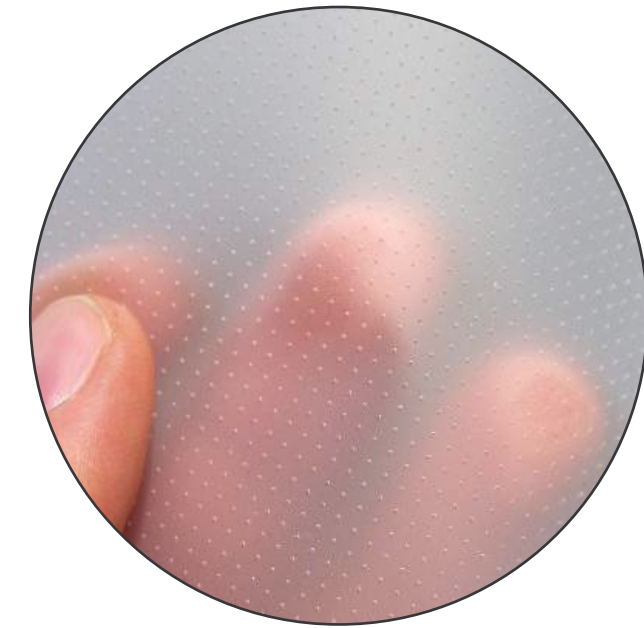
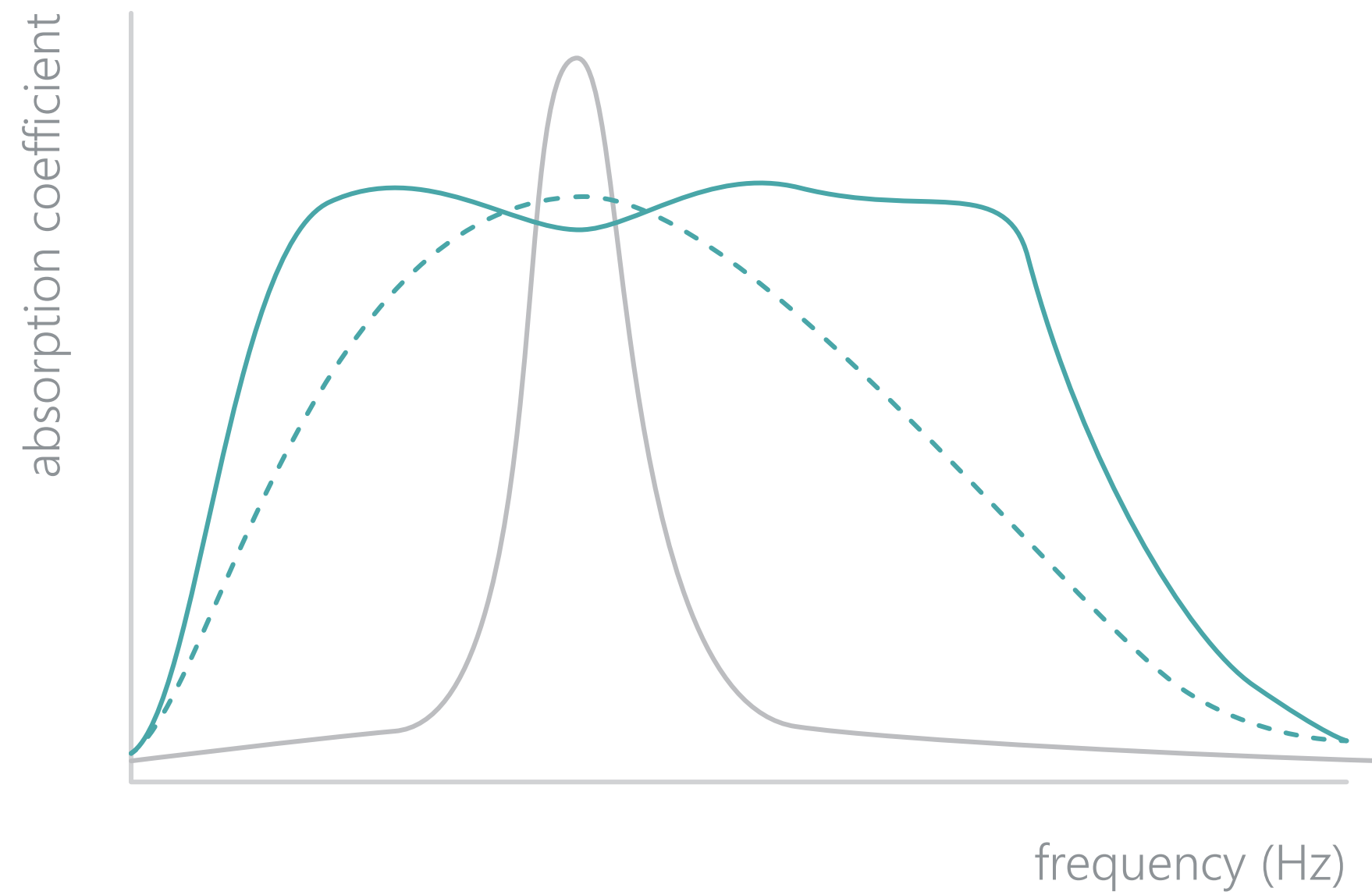

- regular acoustic material
- - - single layer MP fabric
- multi-layer MP fabric

CLIMATE CONCEPT

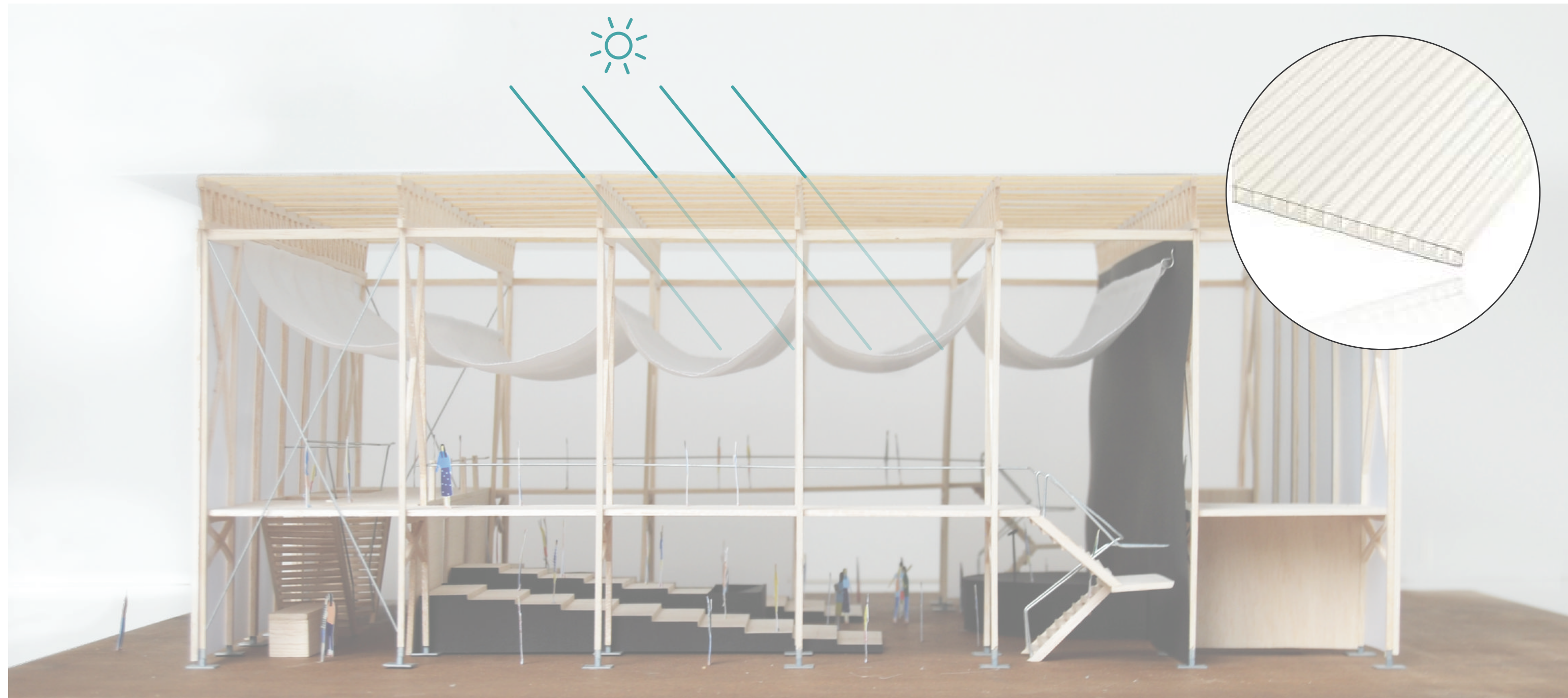

CLIMATE CONCEPT

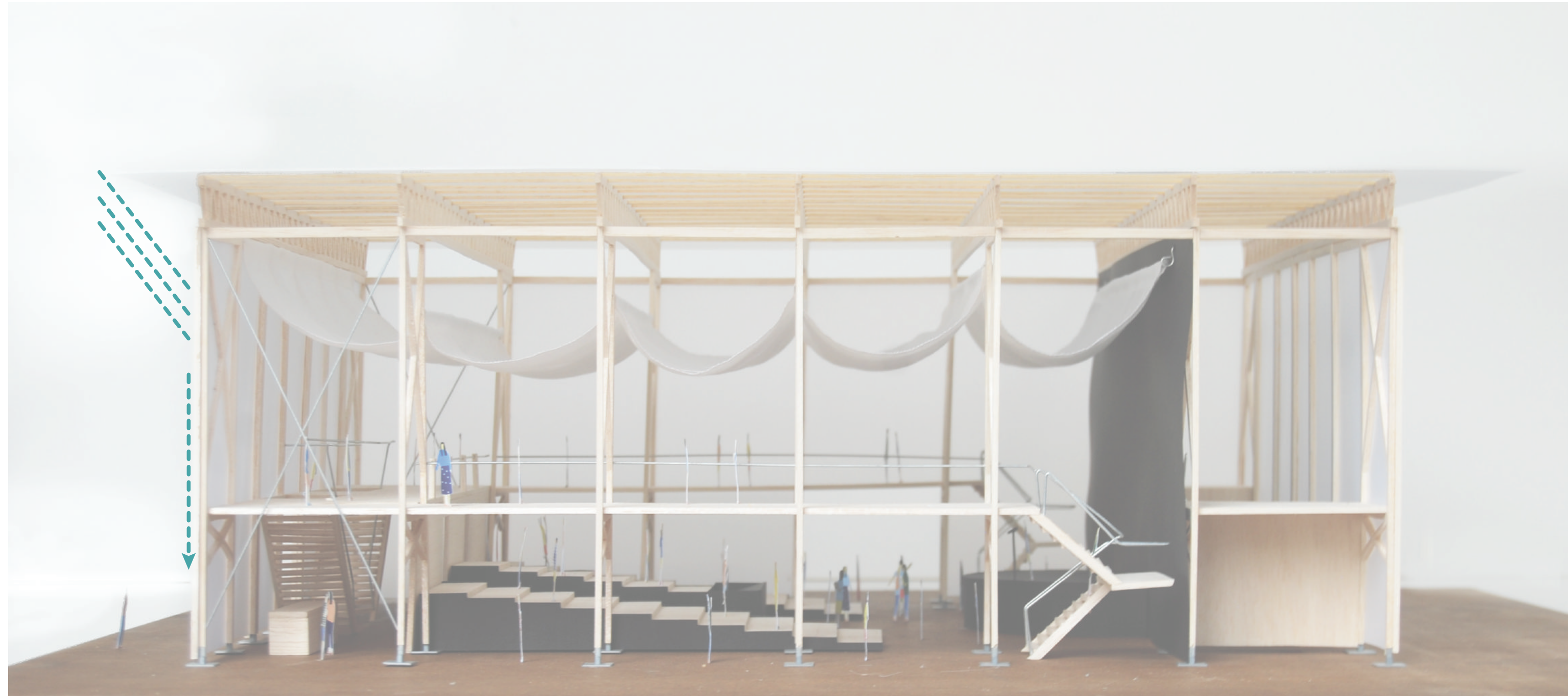

CLIMATE CONCEPT

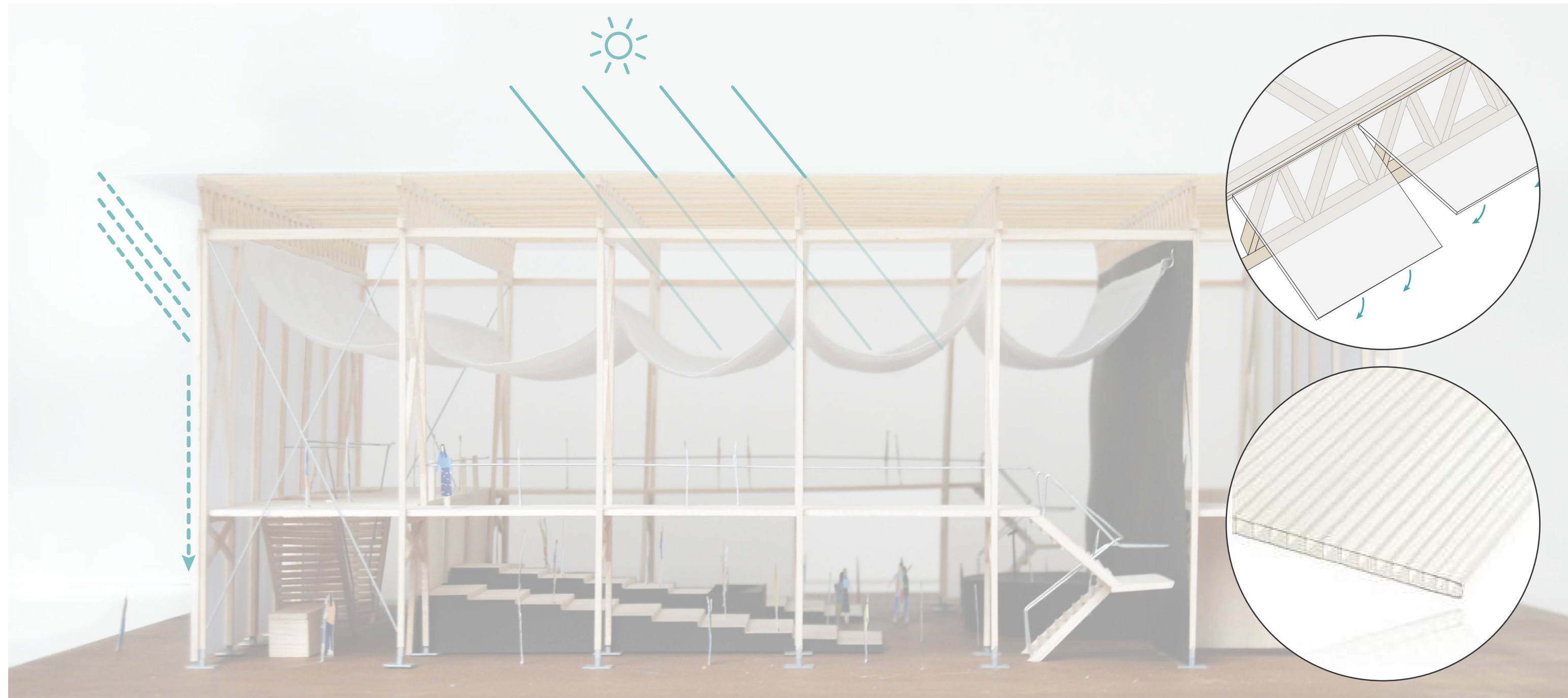

CLIMATE CONCEPT

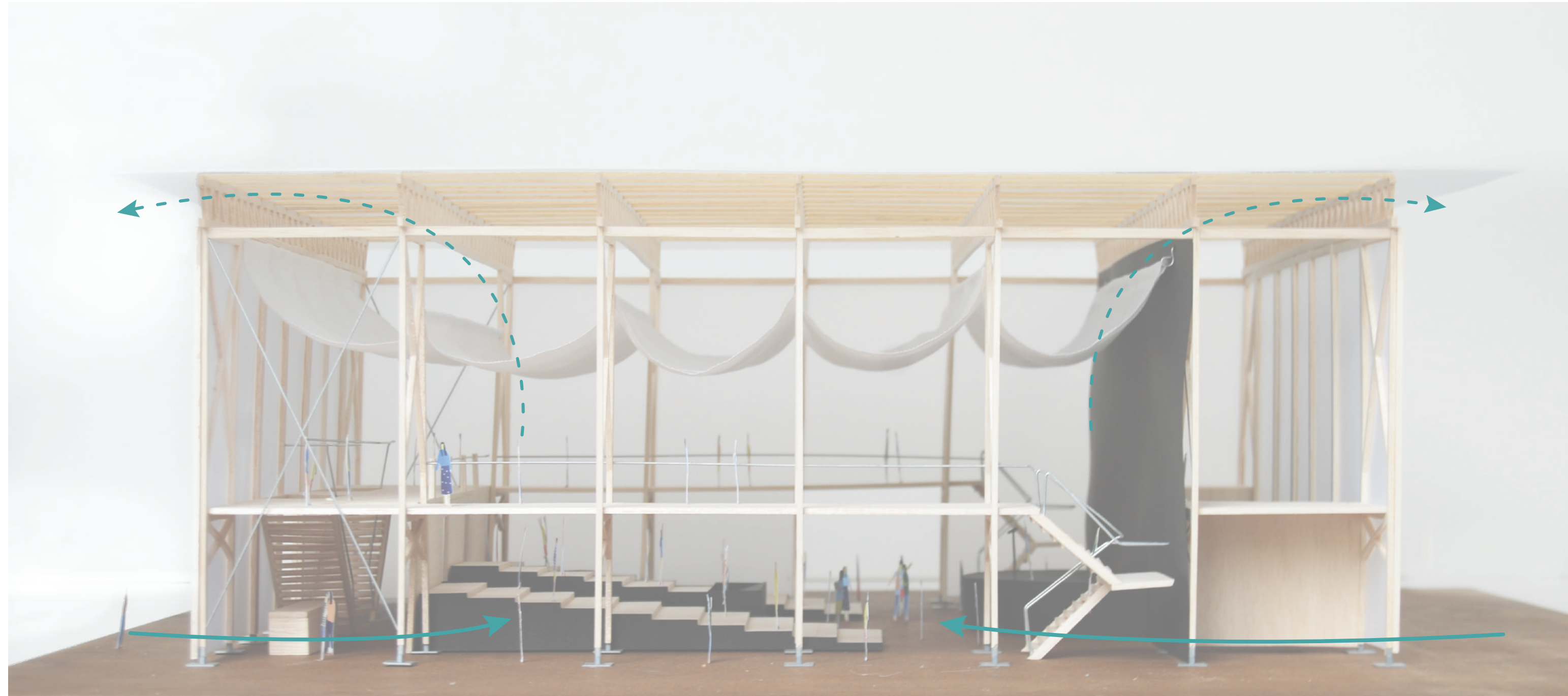

CLIMATE CONCEPT











HOW TO BUILD IT

STEP 1

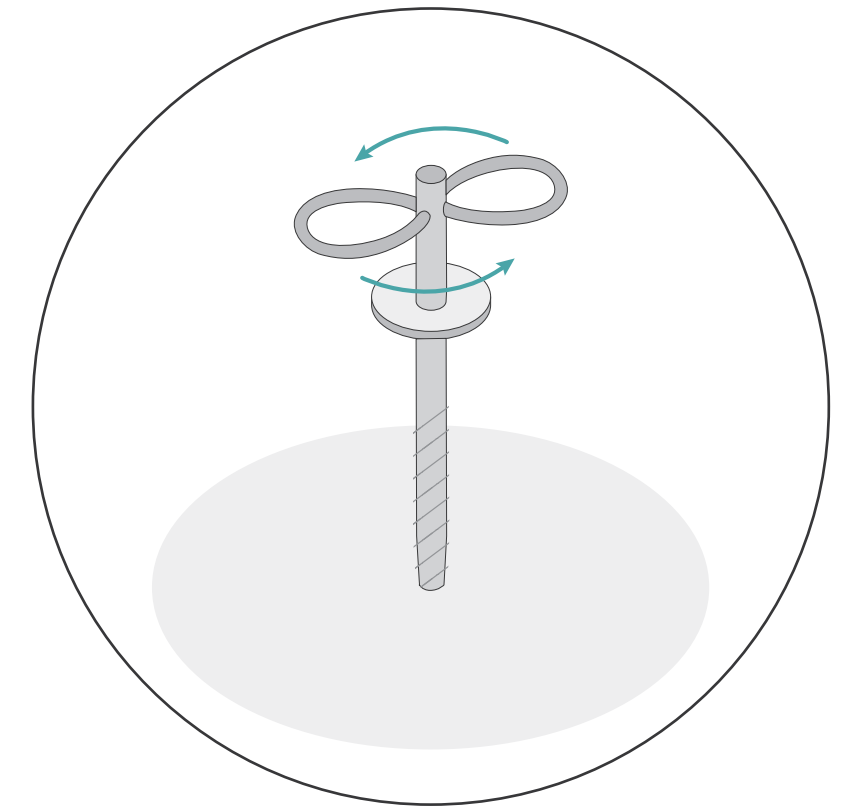

STEP 1

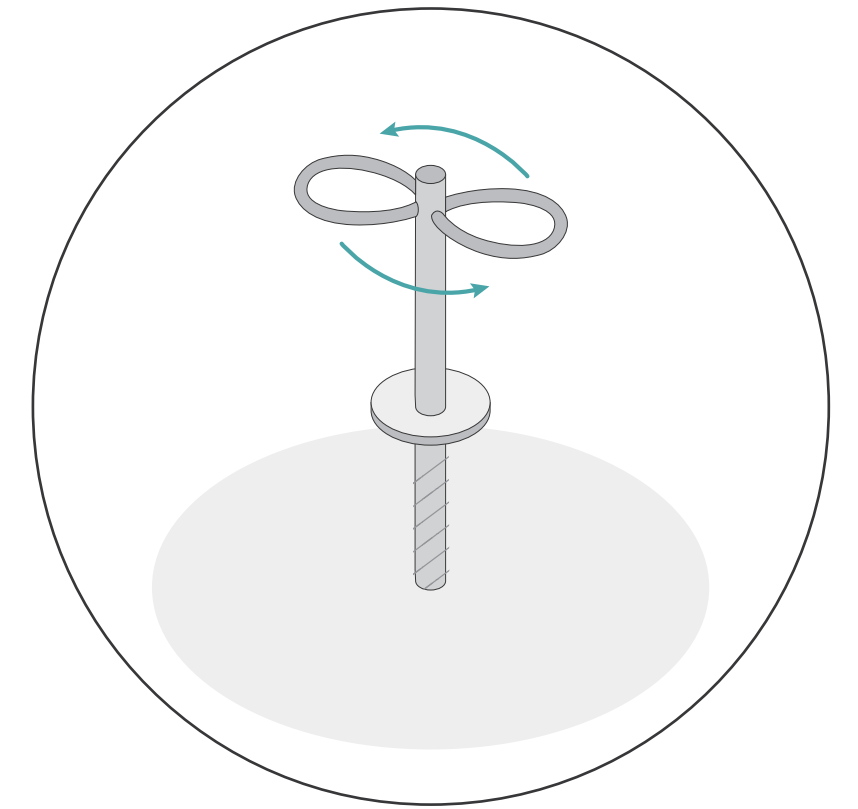

STEP 1

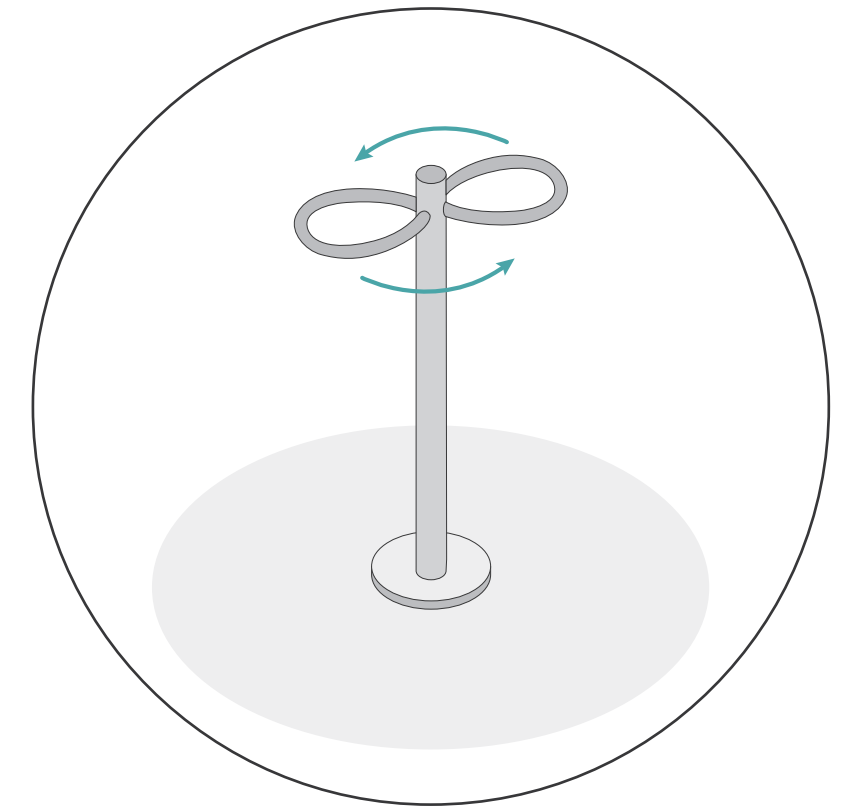

STEP 2

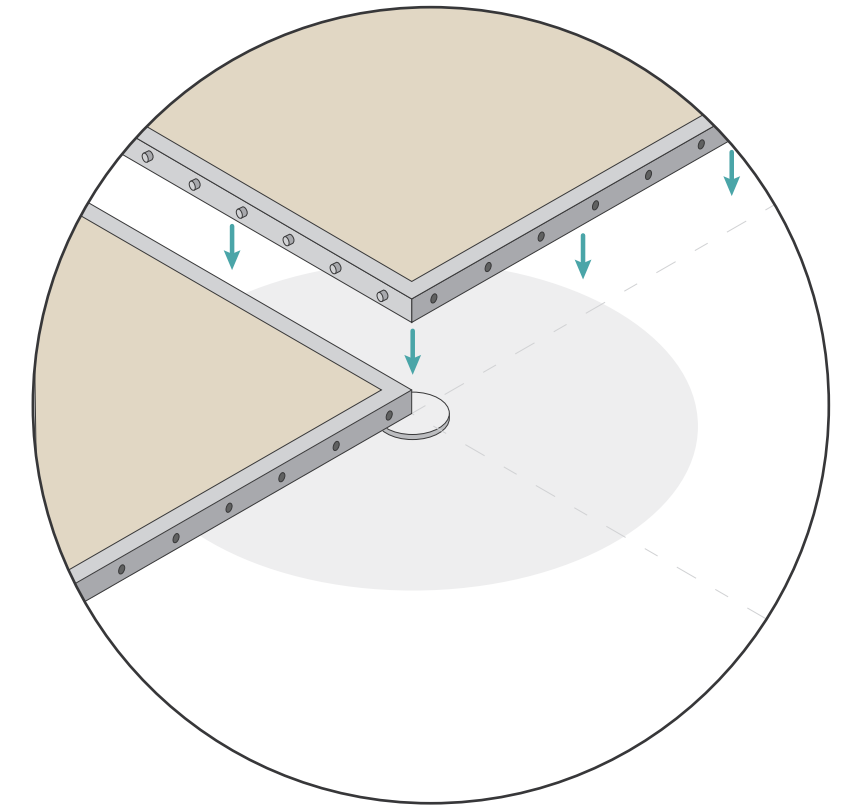
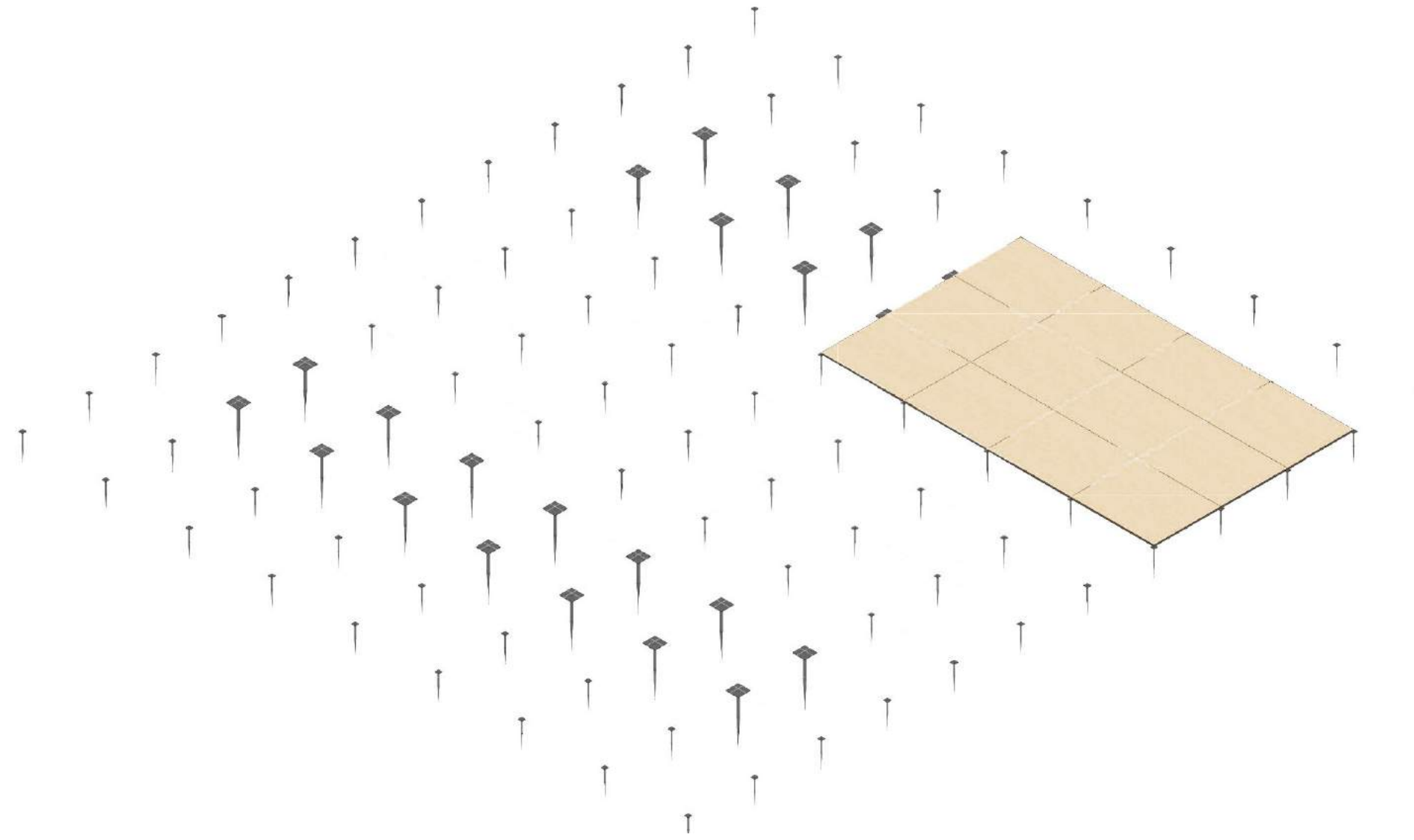

STEP 3

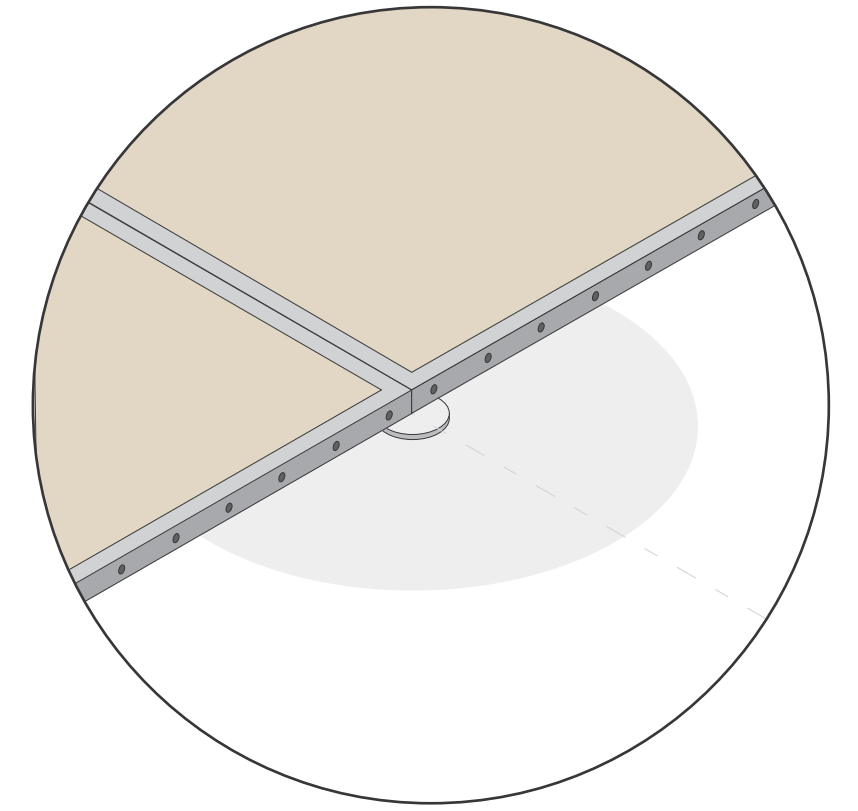
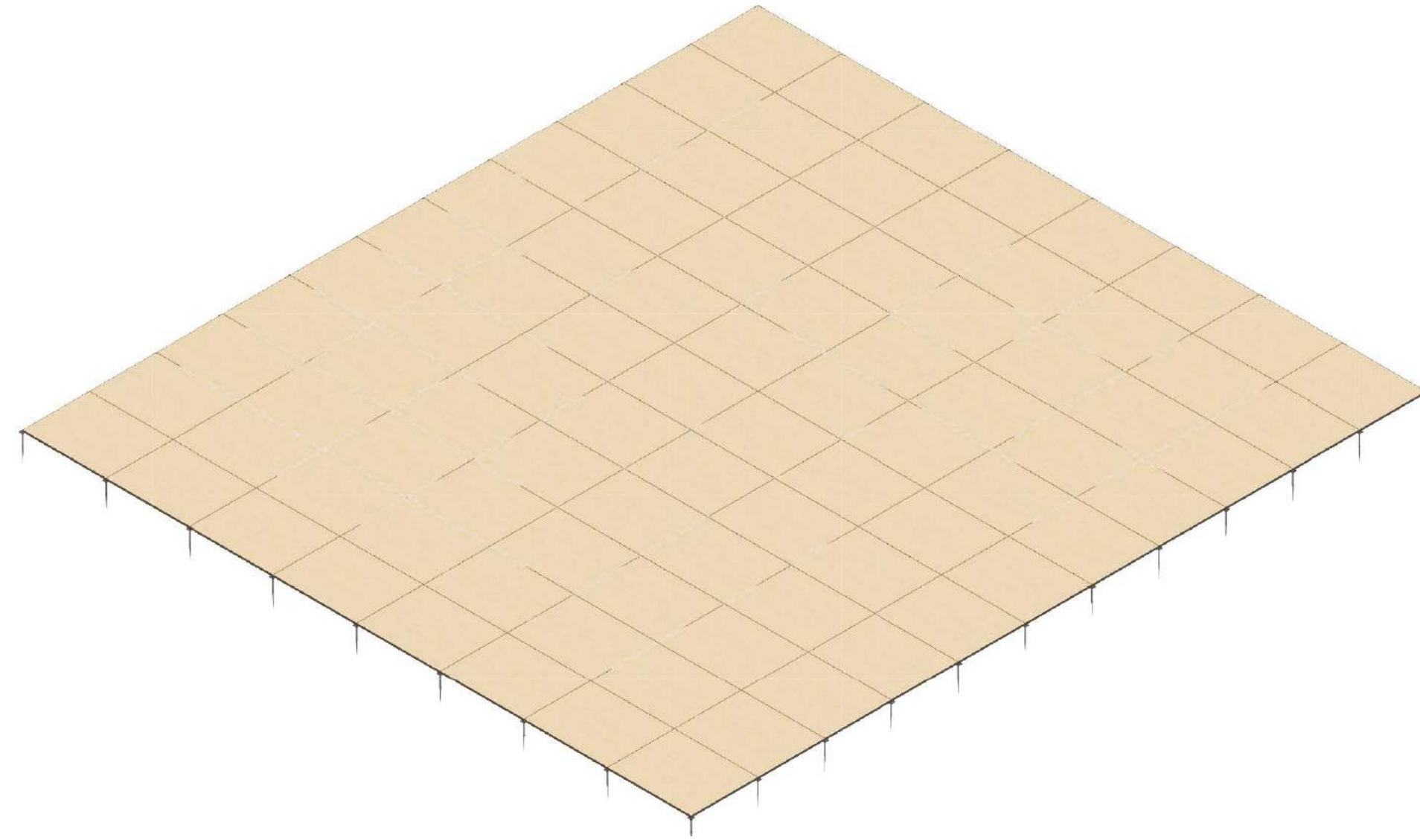

STEP 4

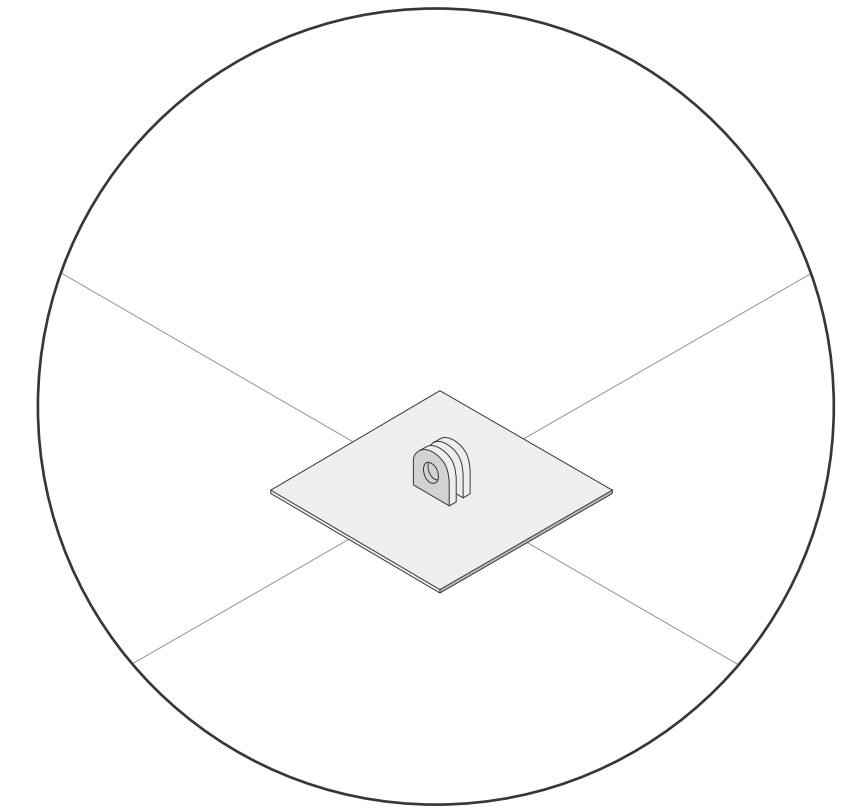
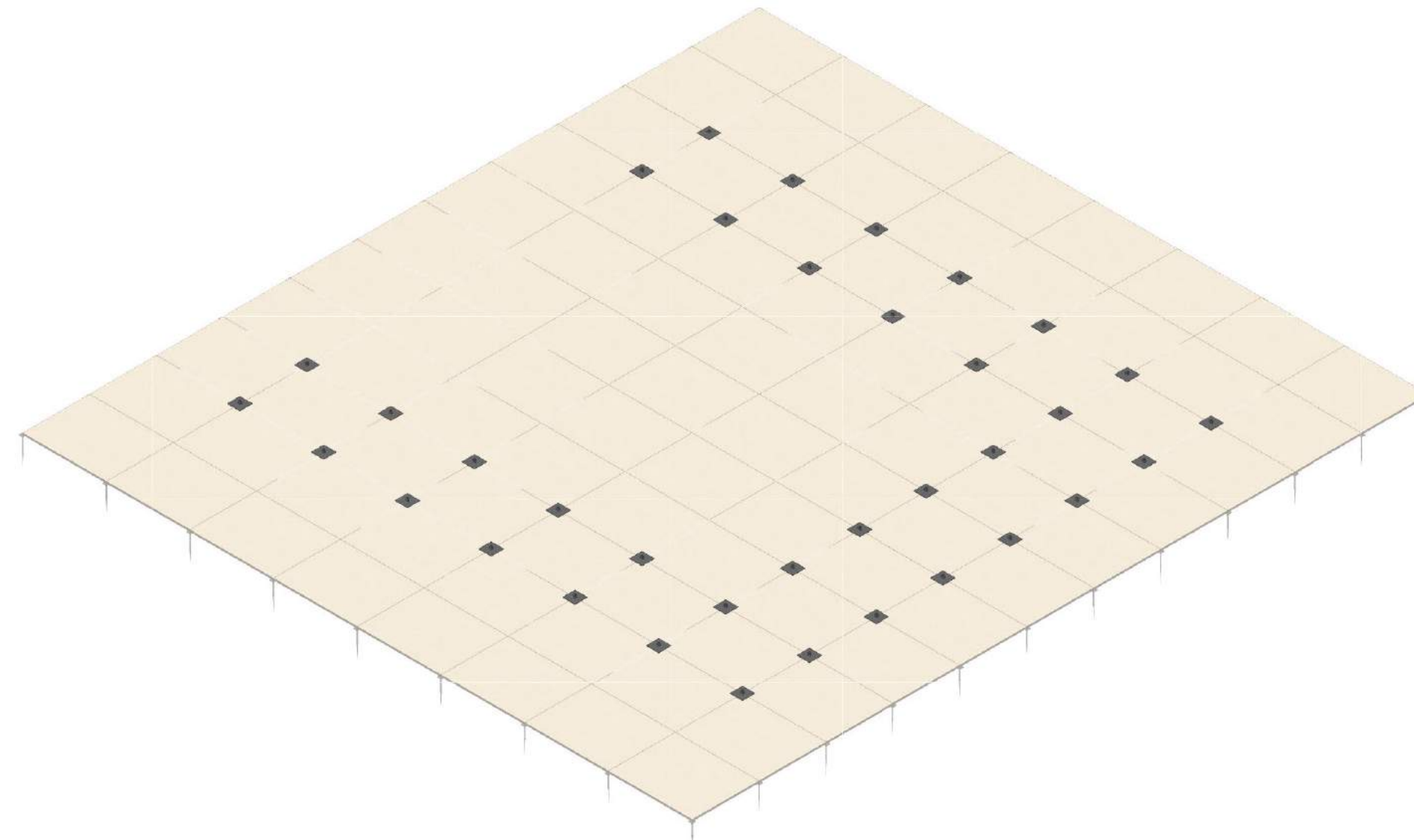

STEP 5

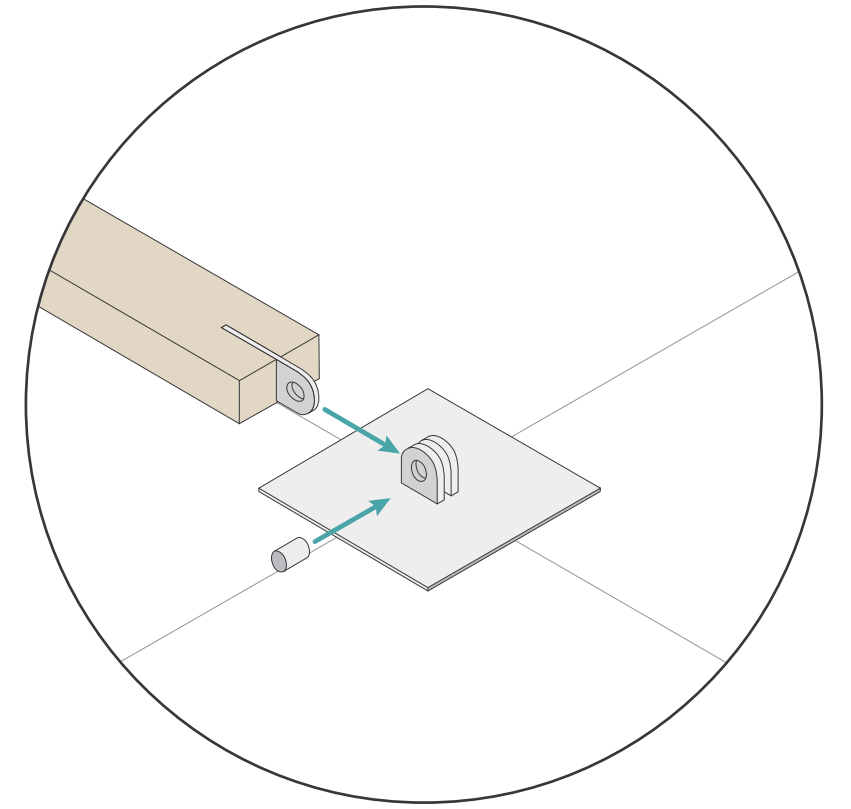
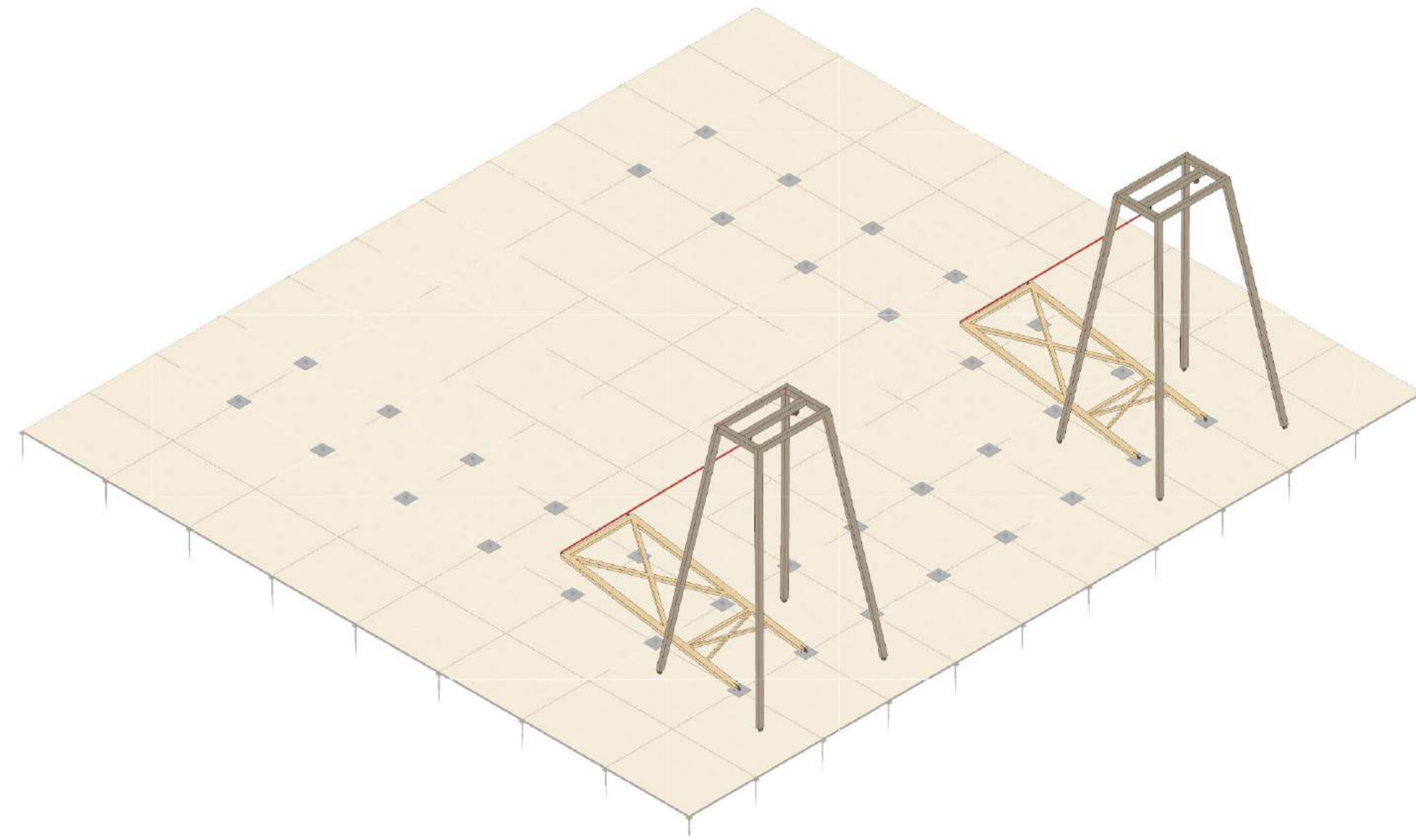

STEP 5

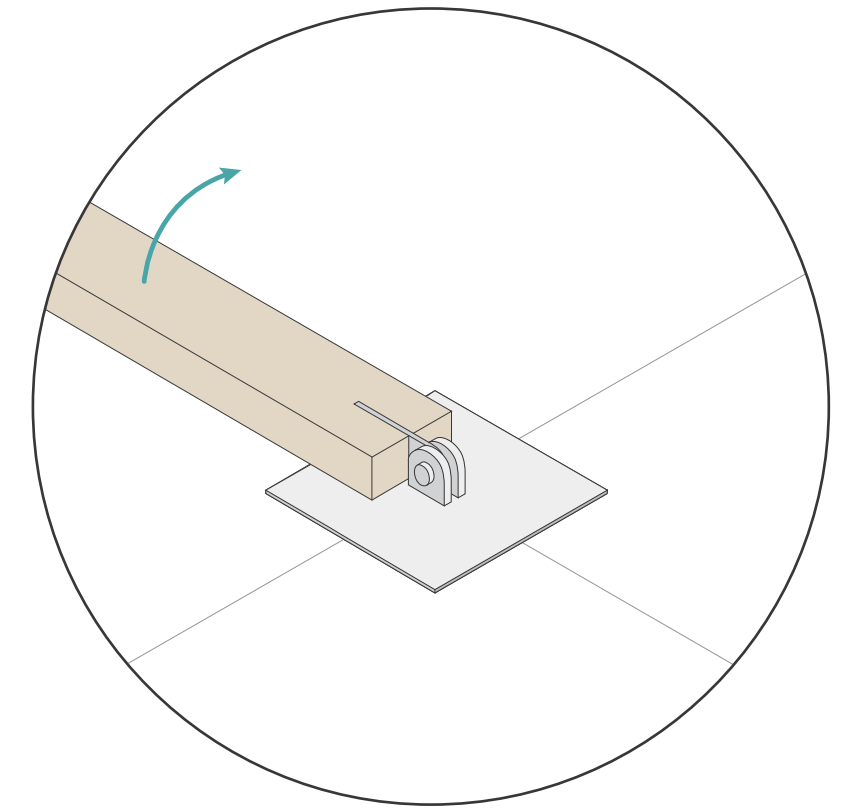
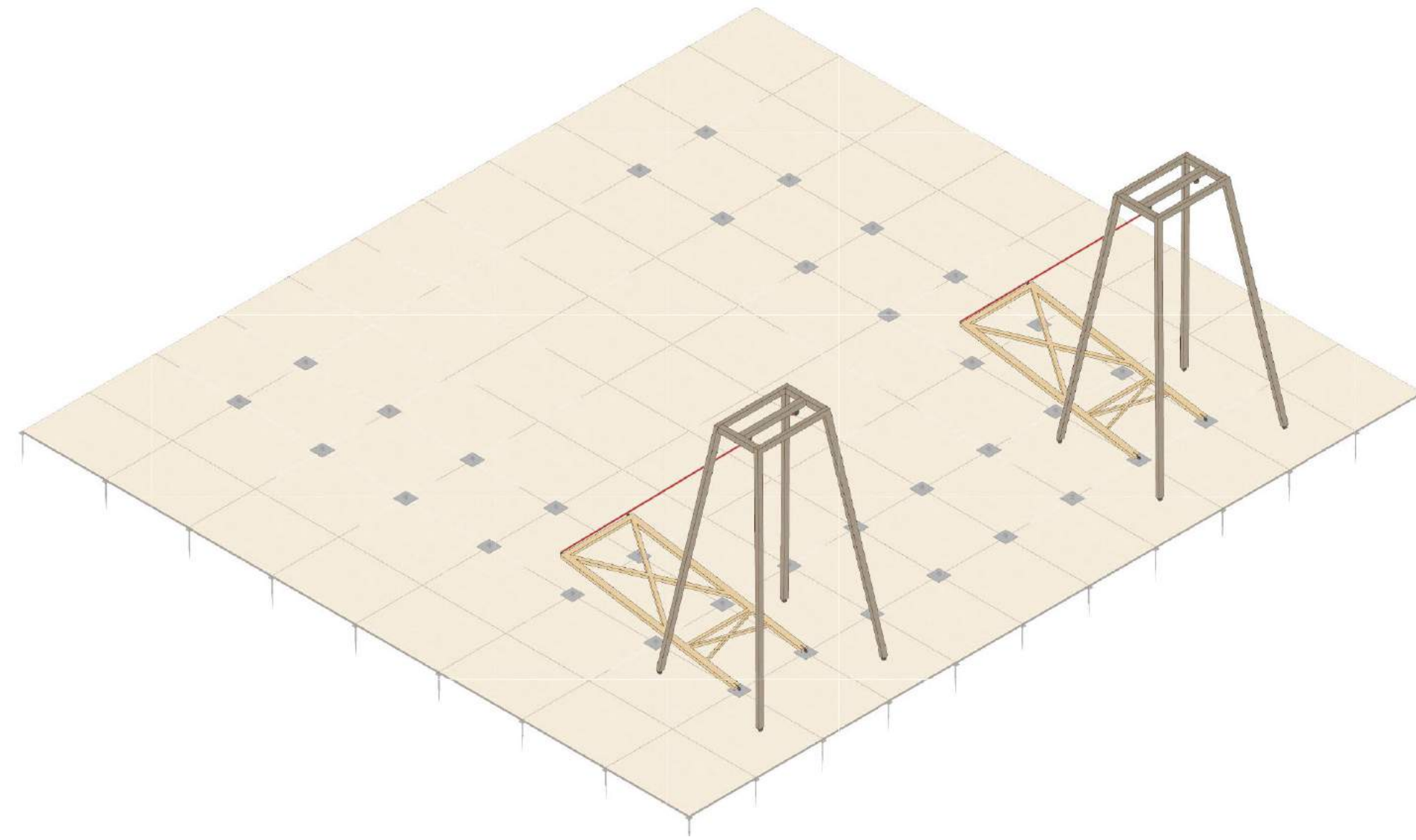

STEP 5

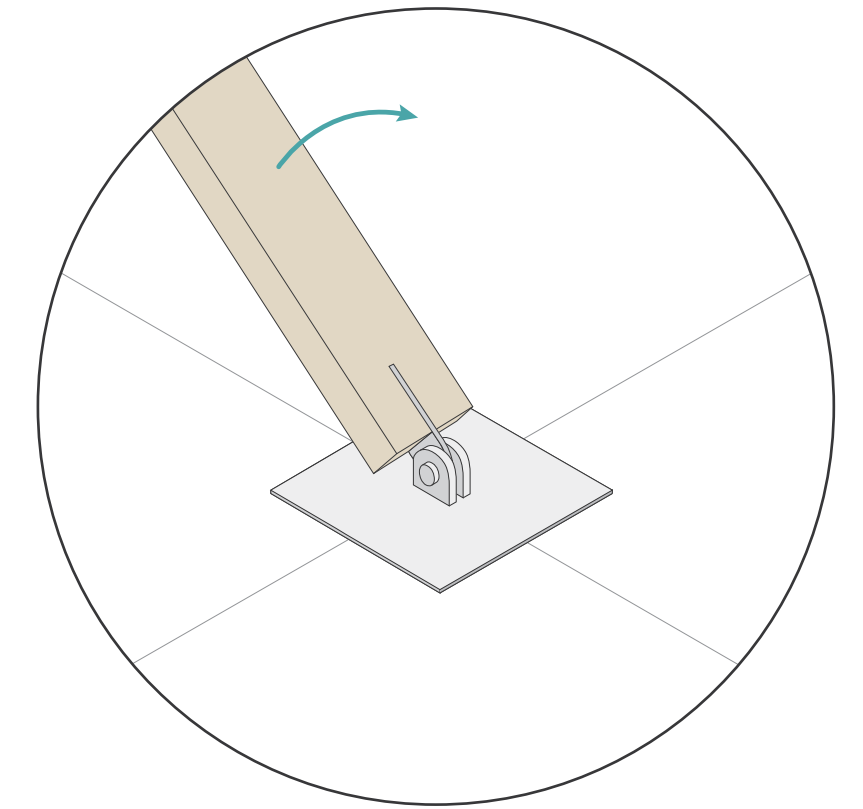
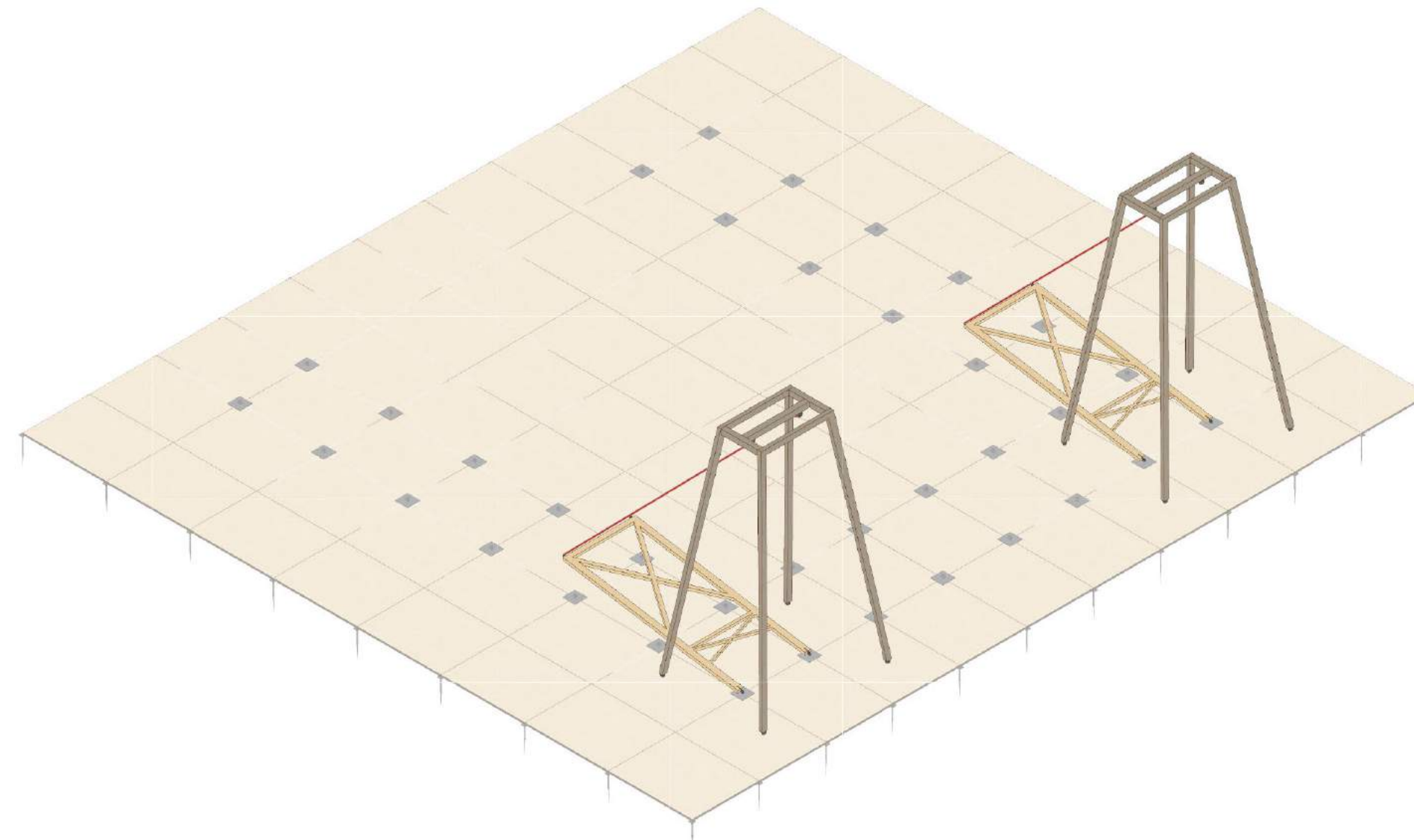

STEP 5

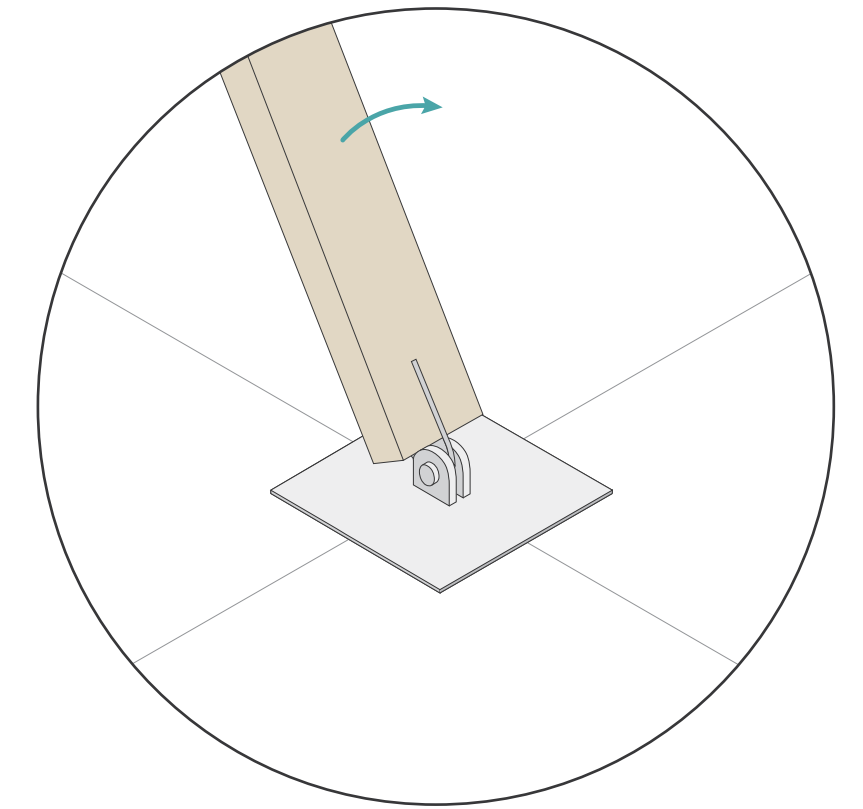
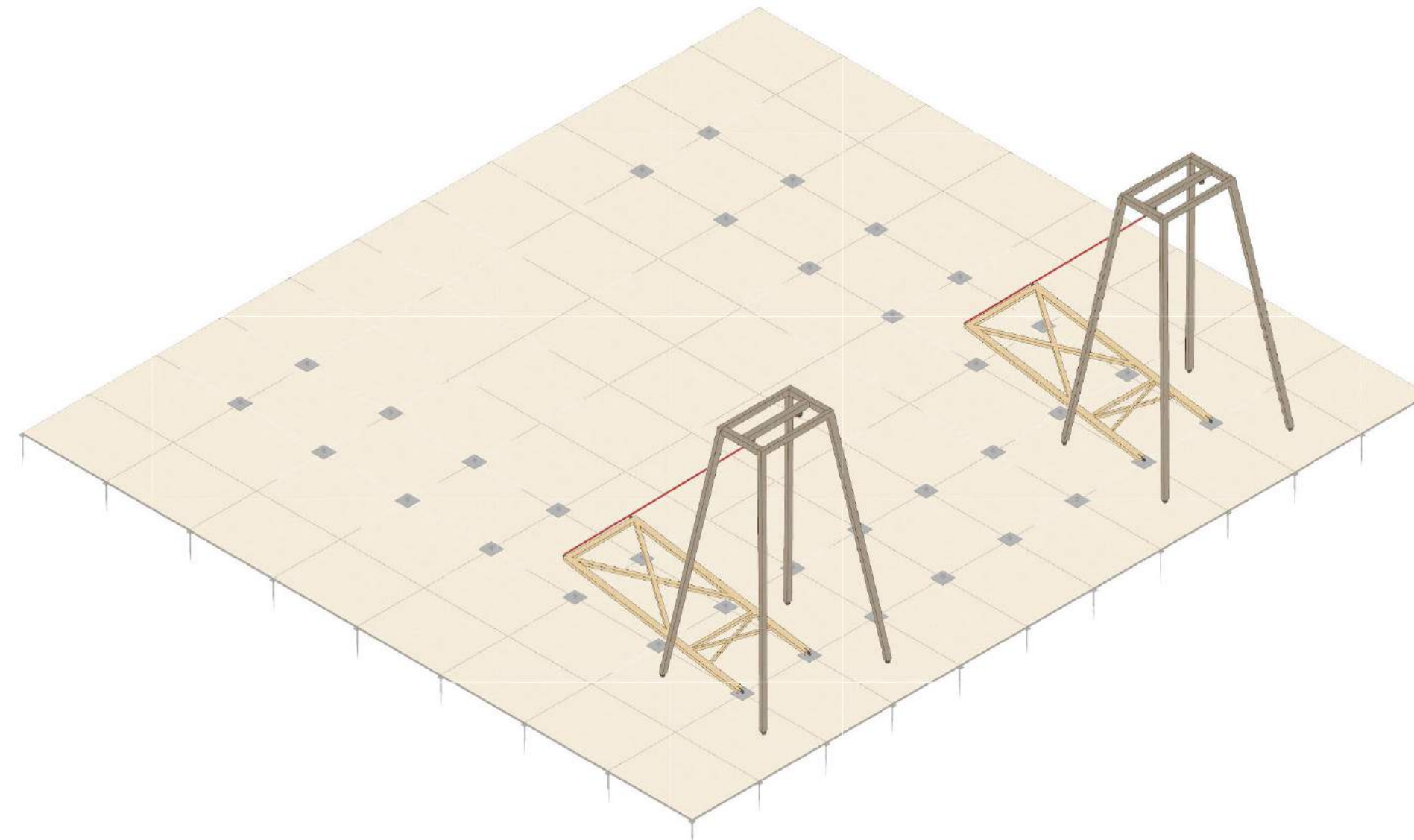

STEP 6

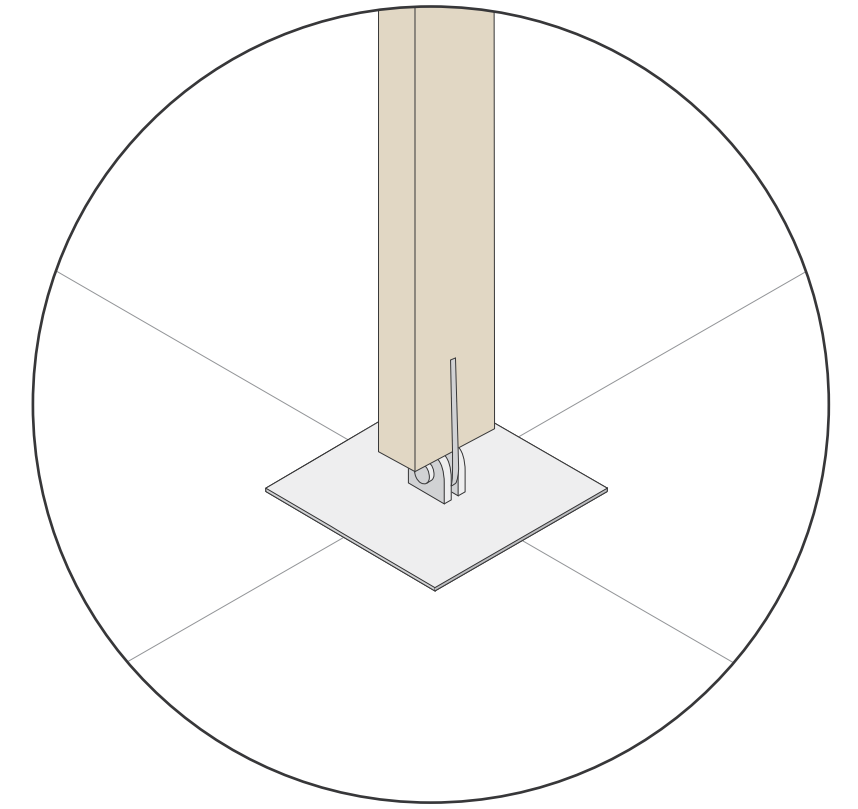
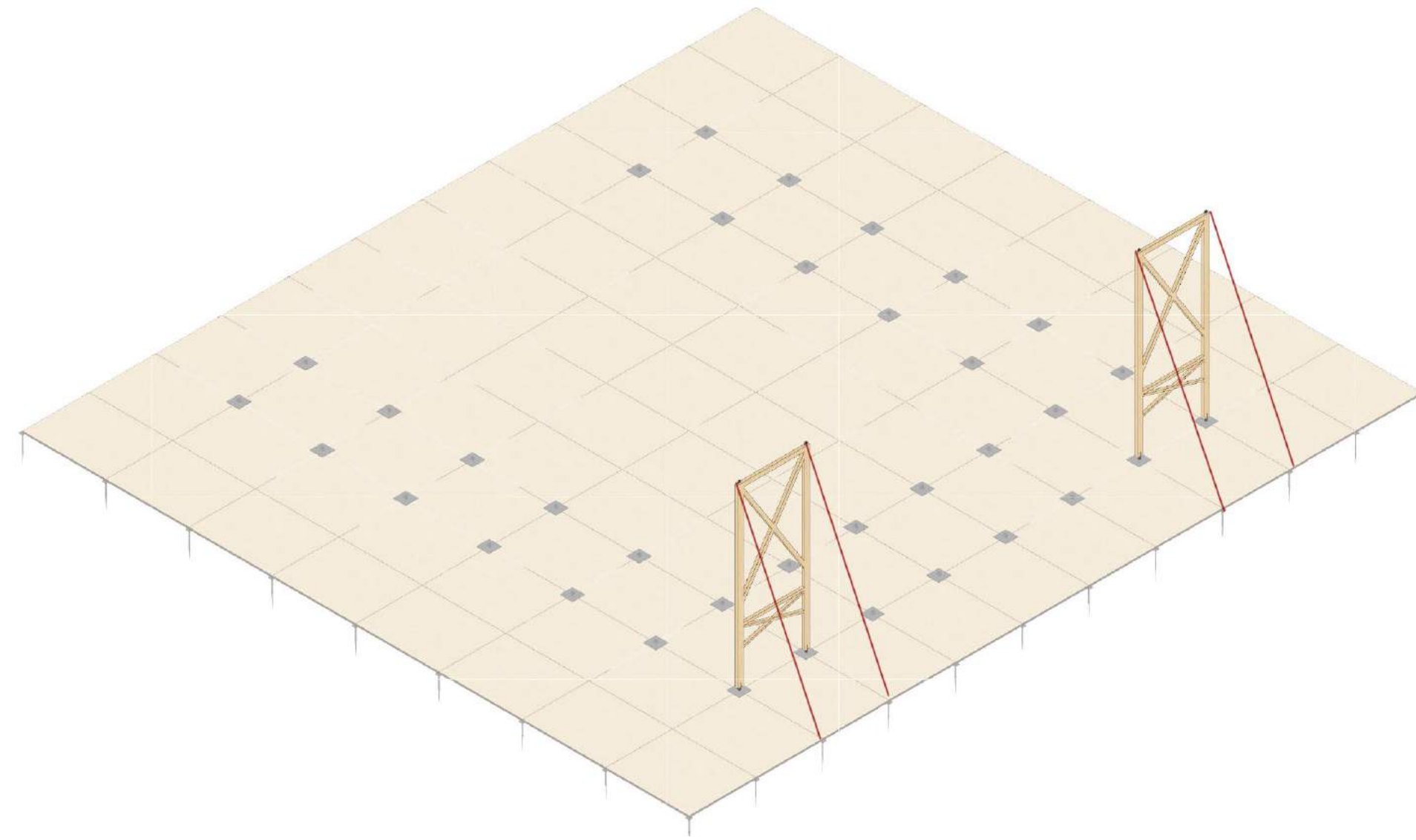

STEP 7

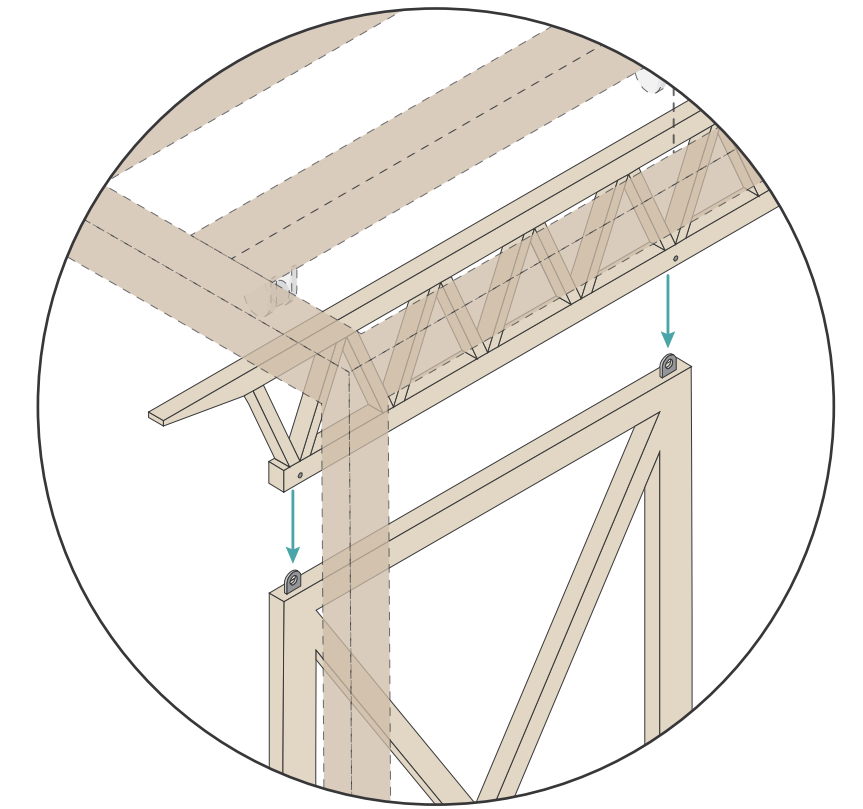
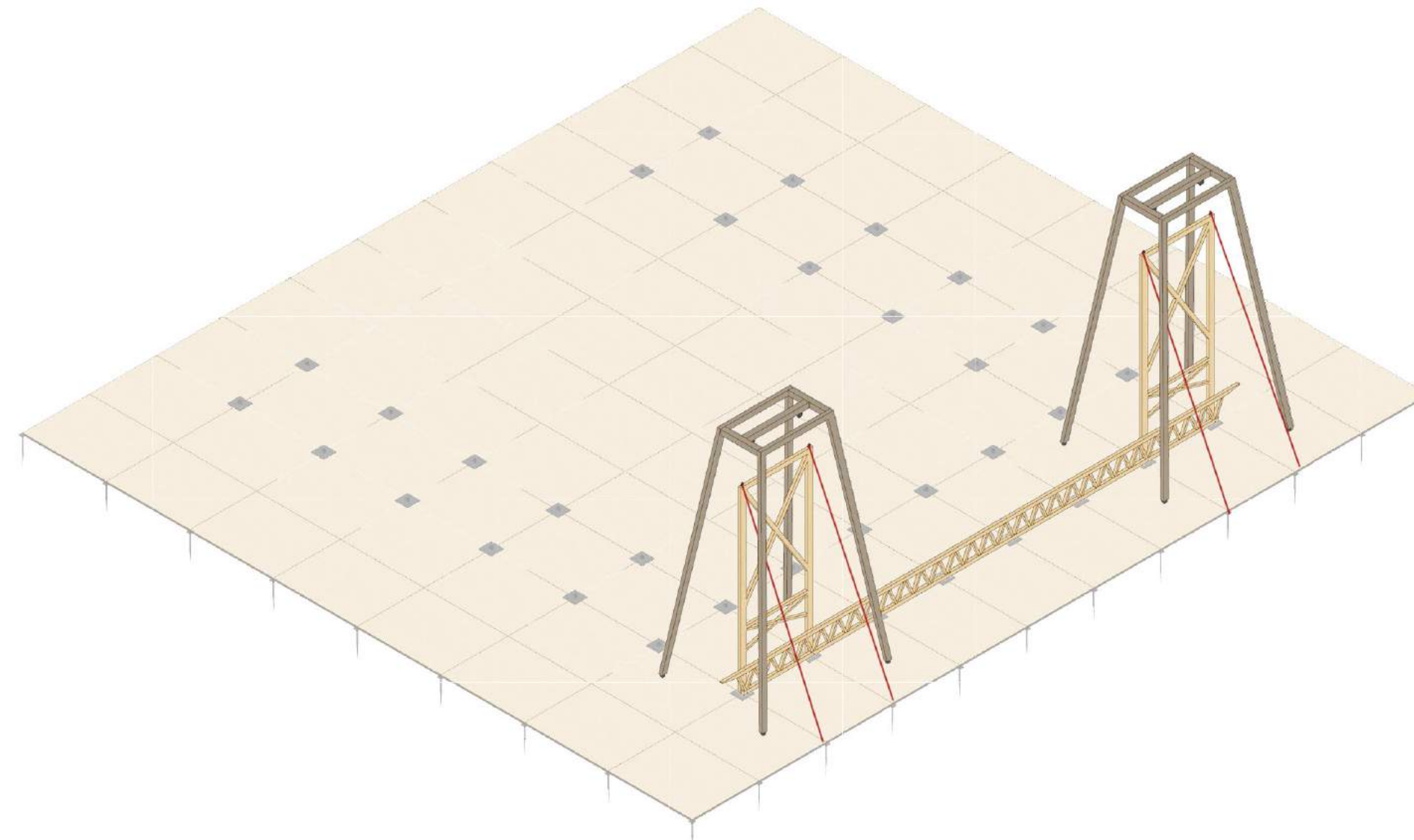

STEP 8

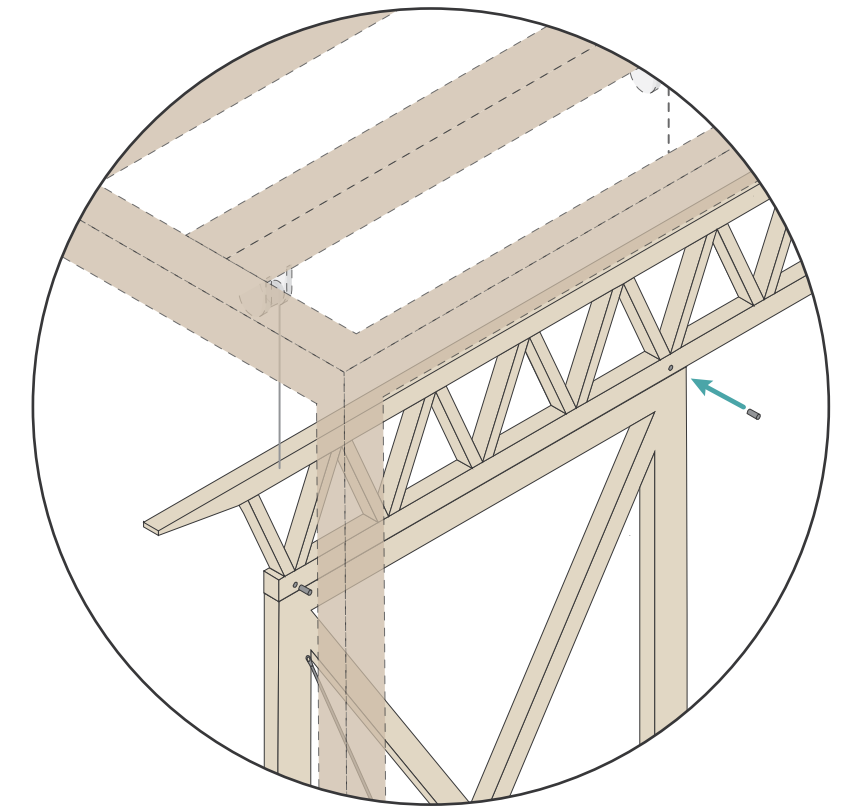
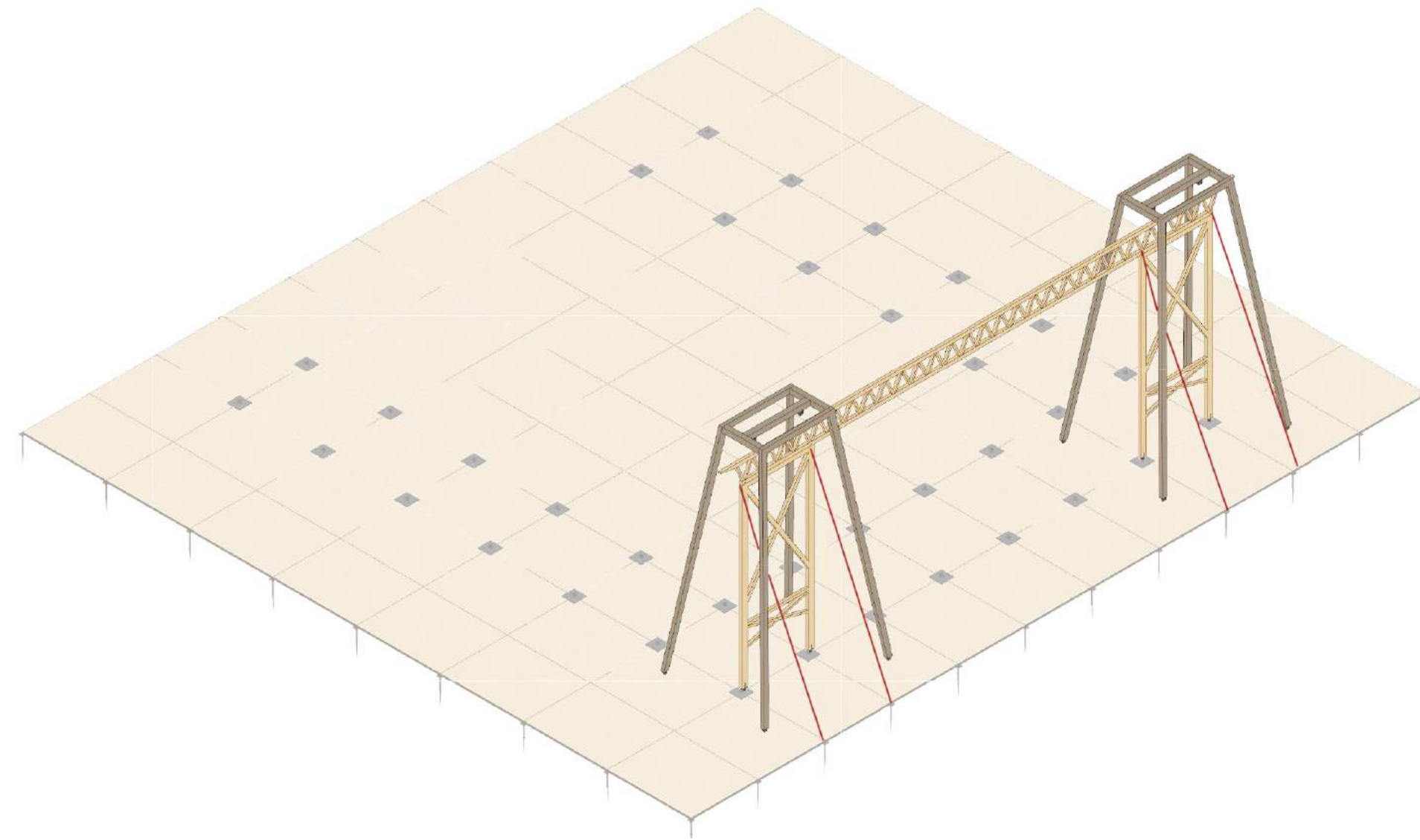

STEP 9

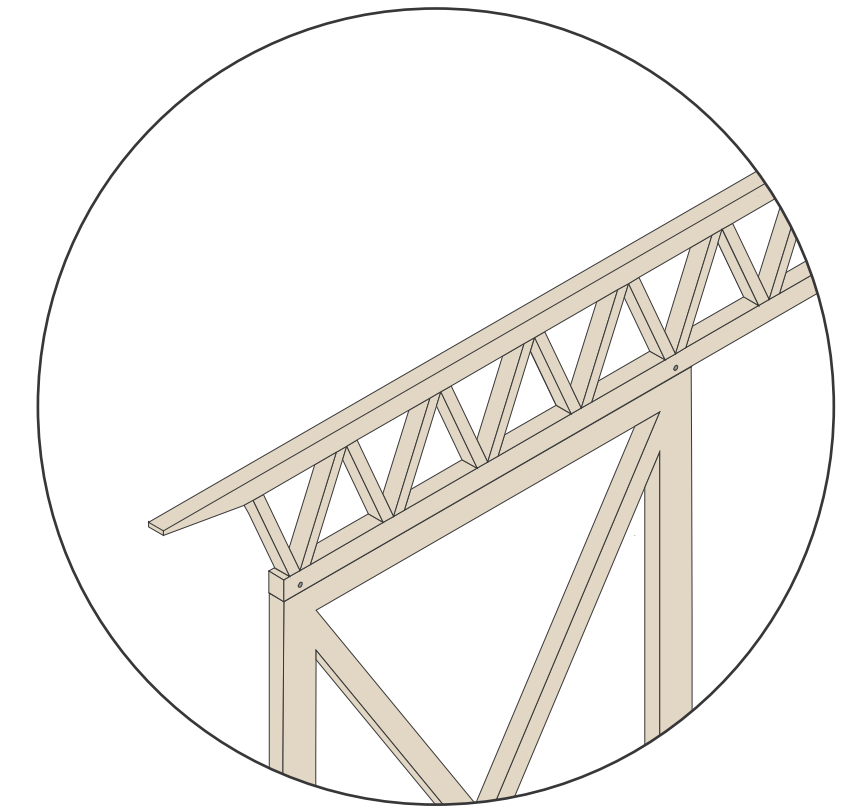
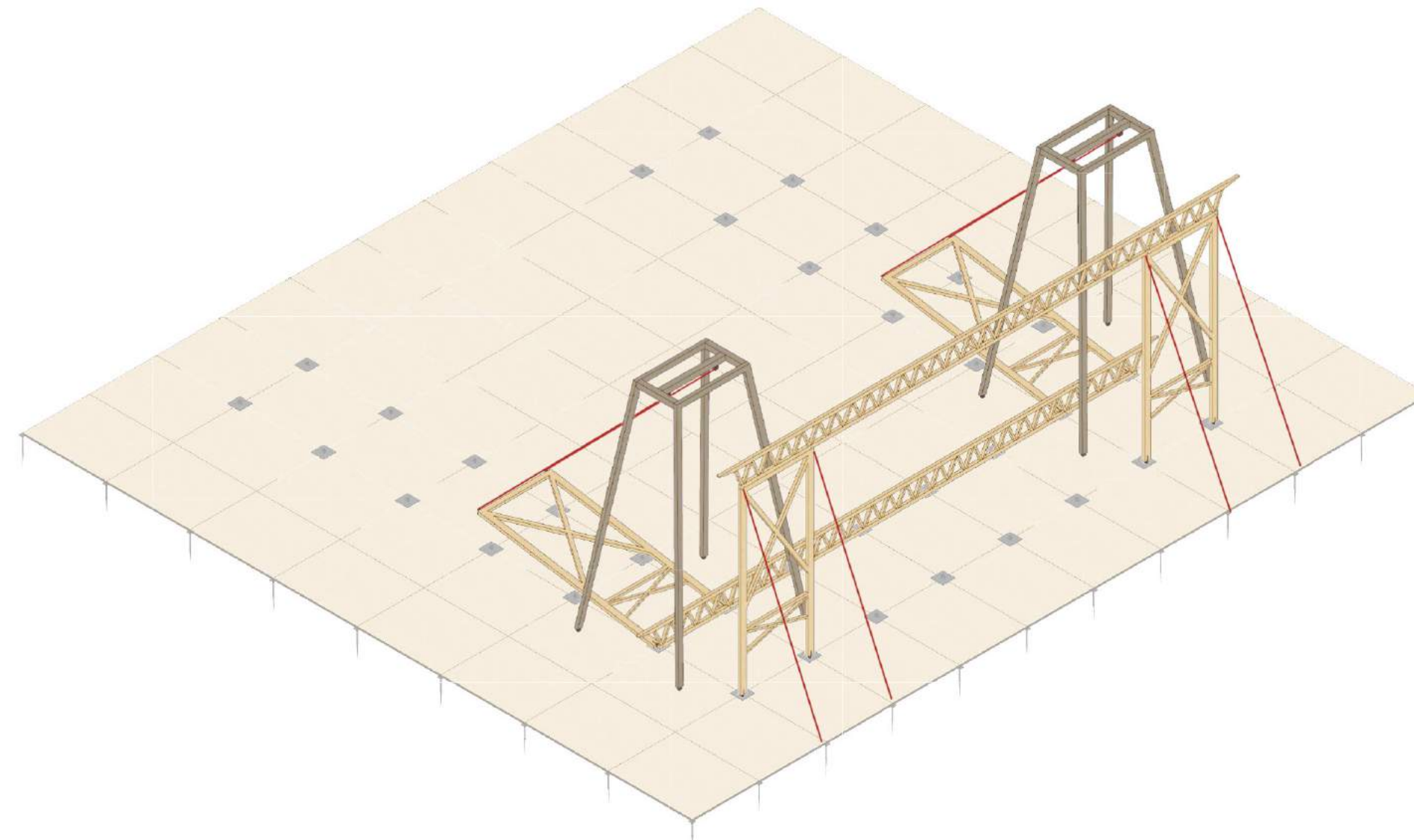

STEP 10

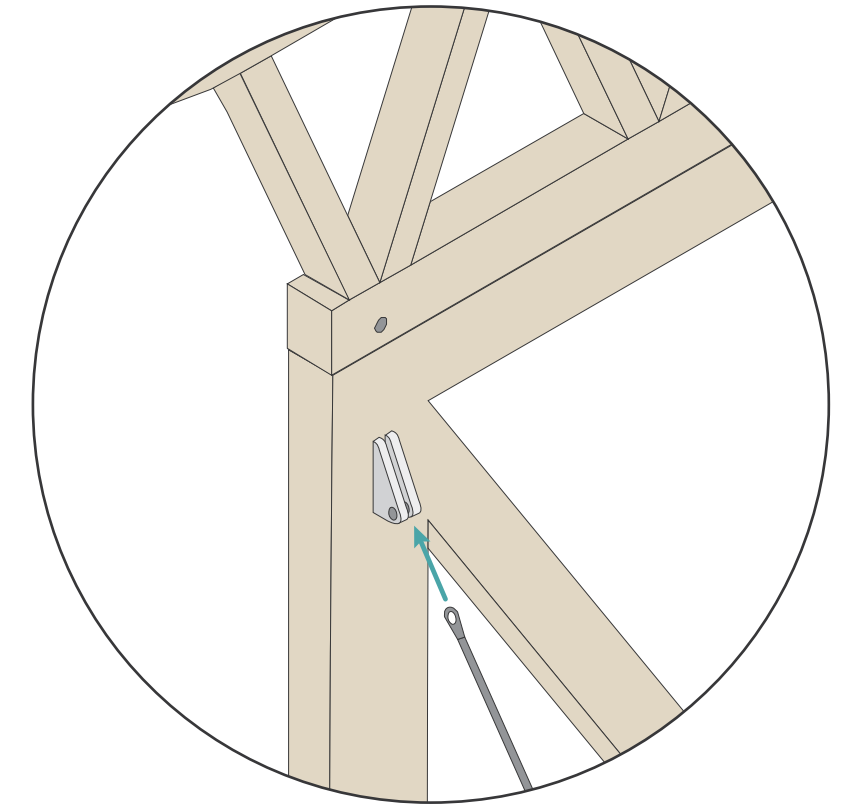
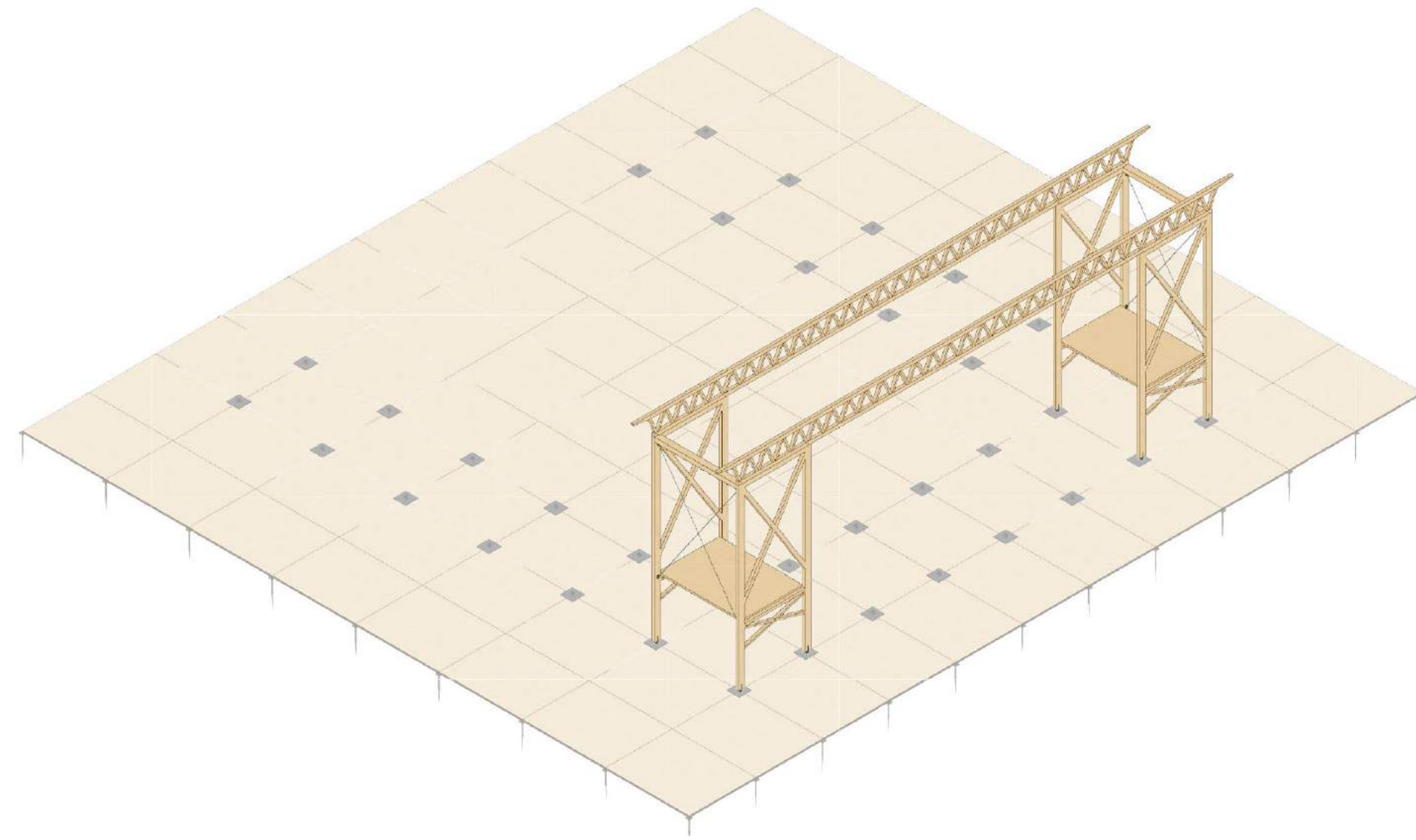

STEP 10

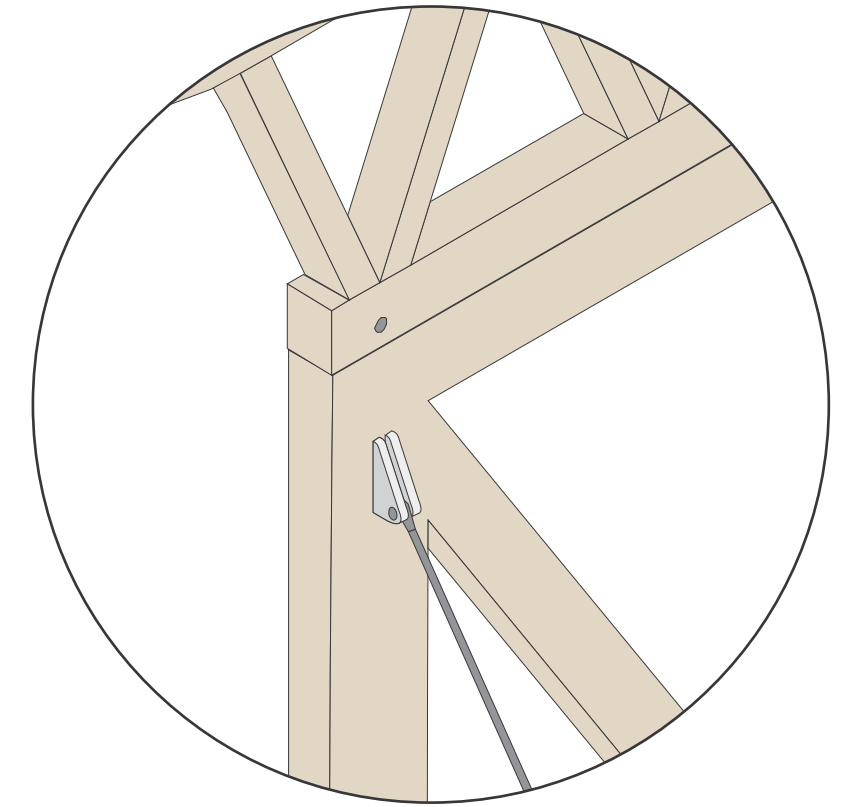
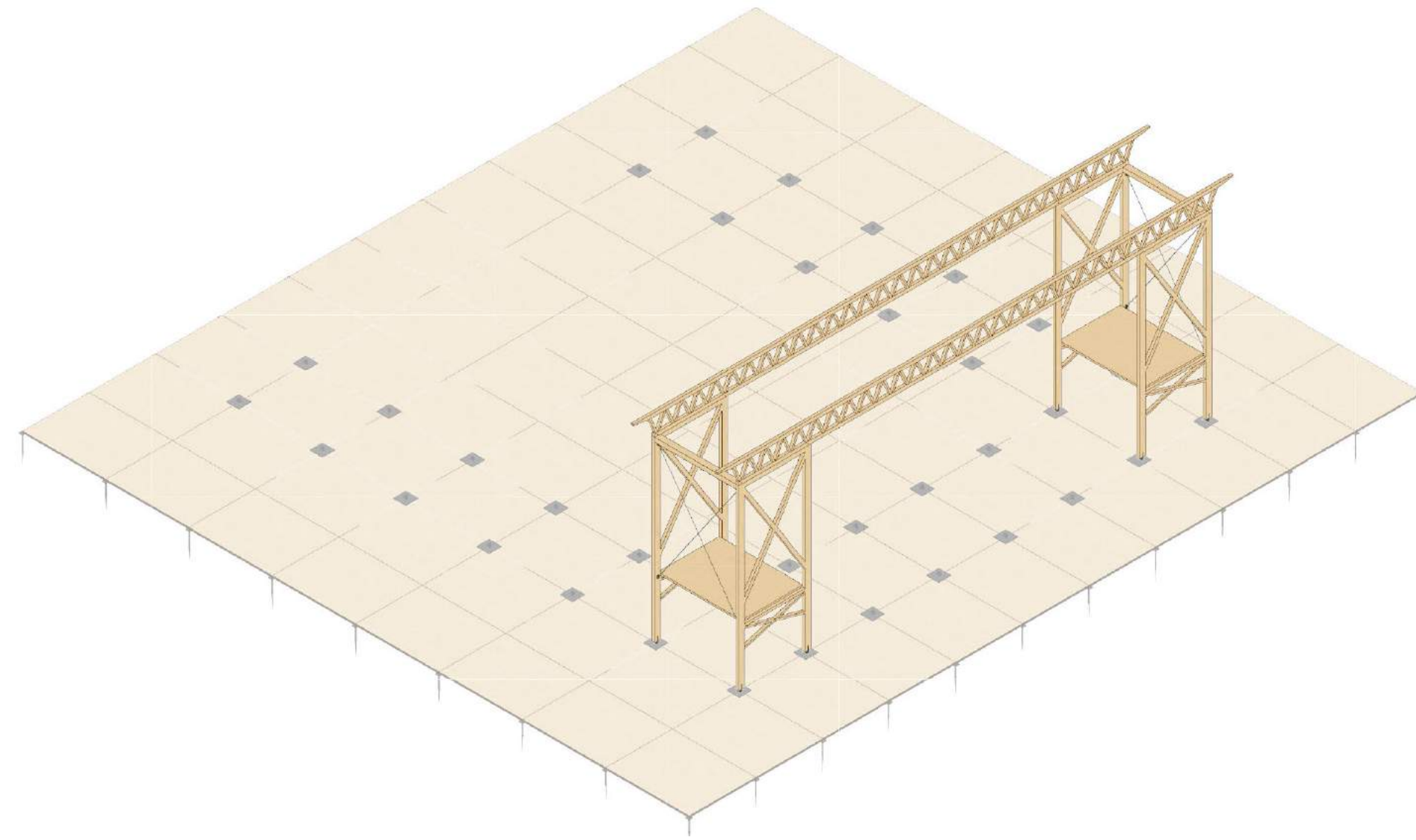

STEP 11

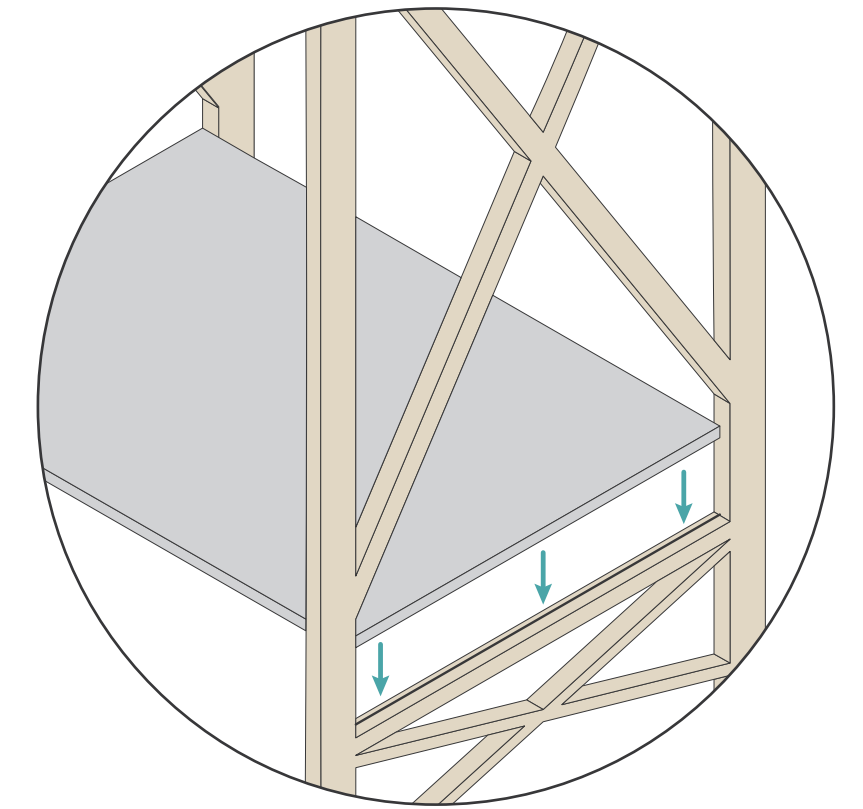
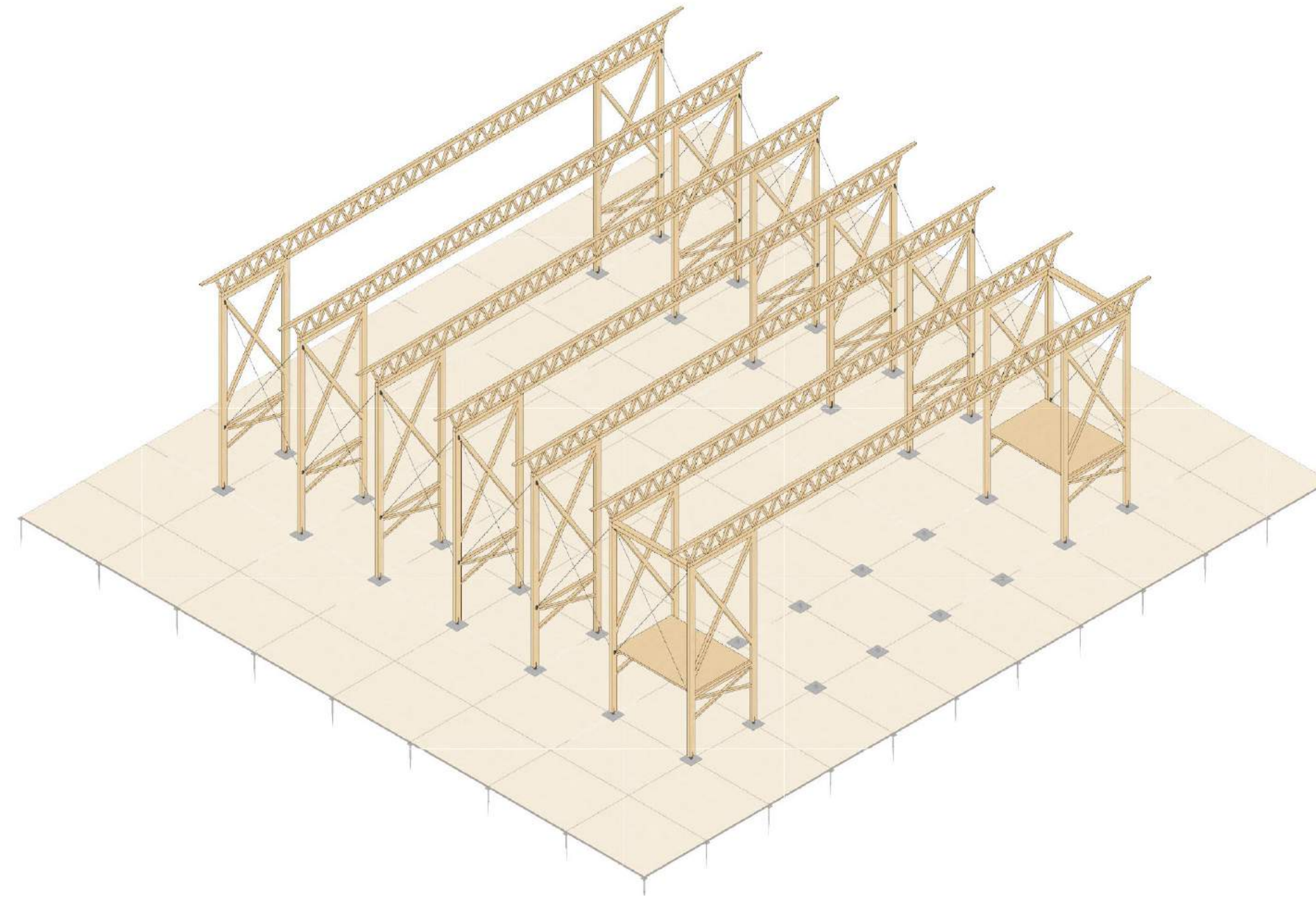

STEP 12

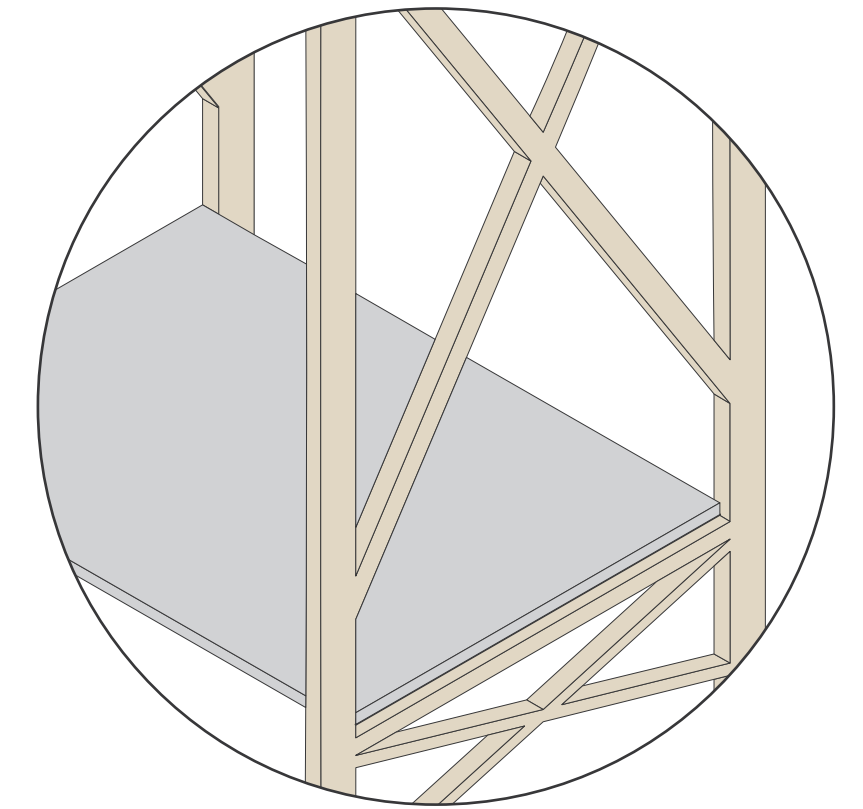
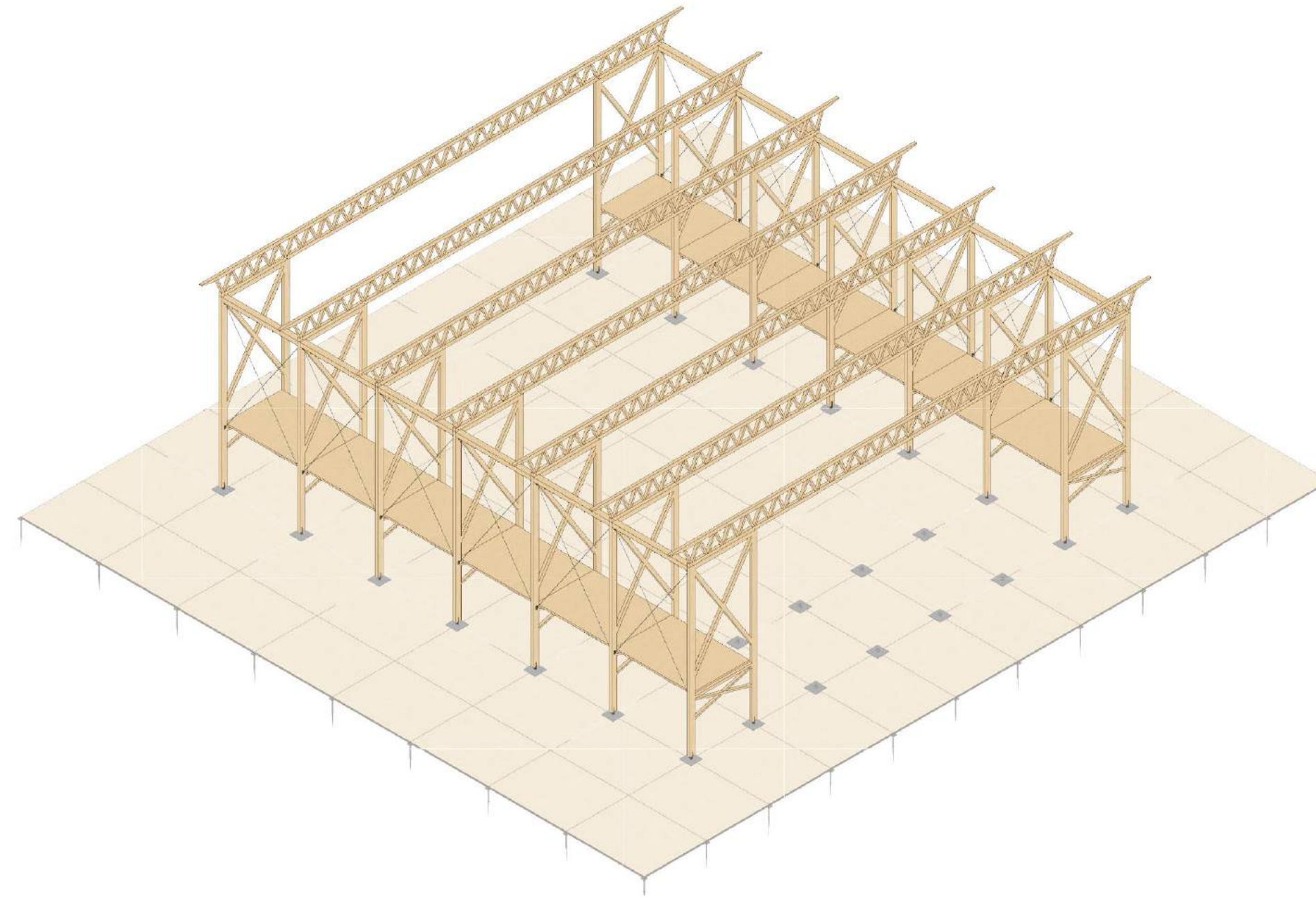

STEP 13

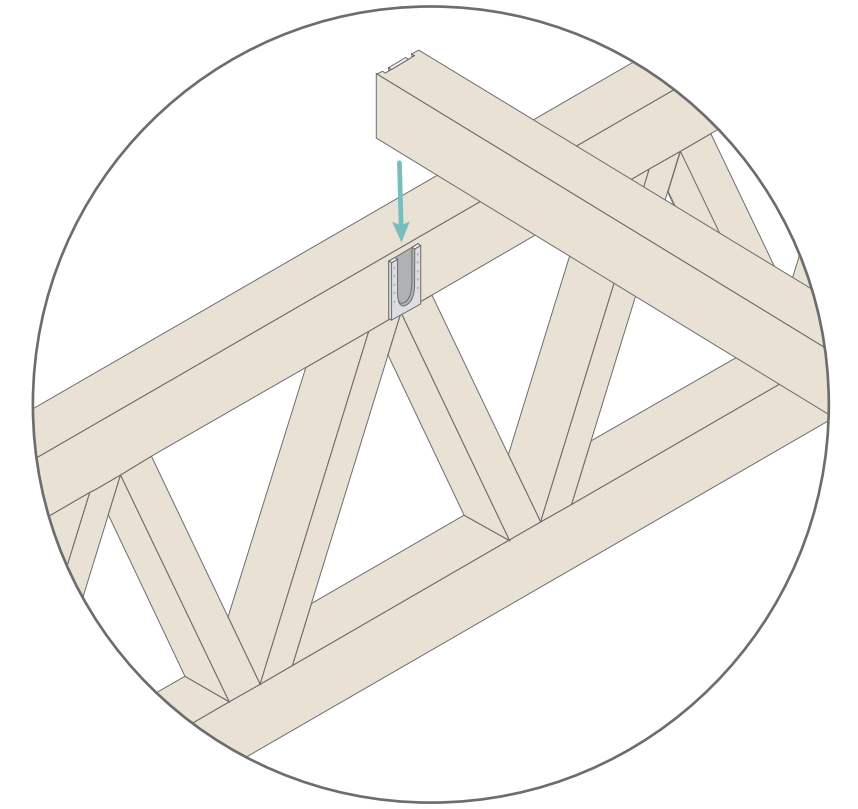
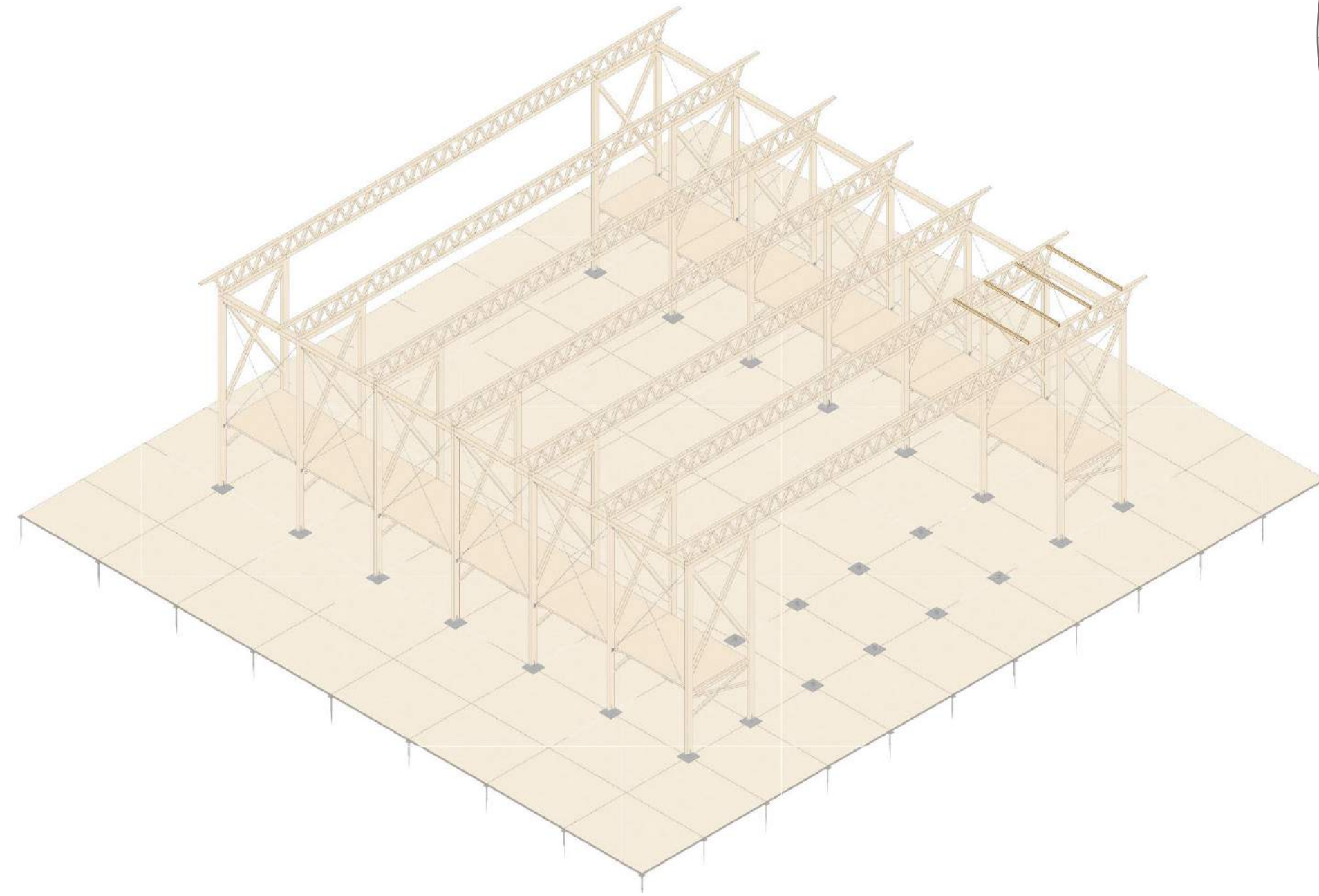

STEP 13

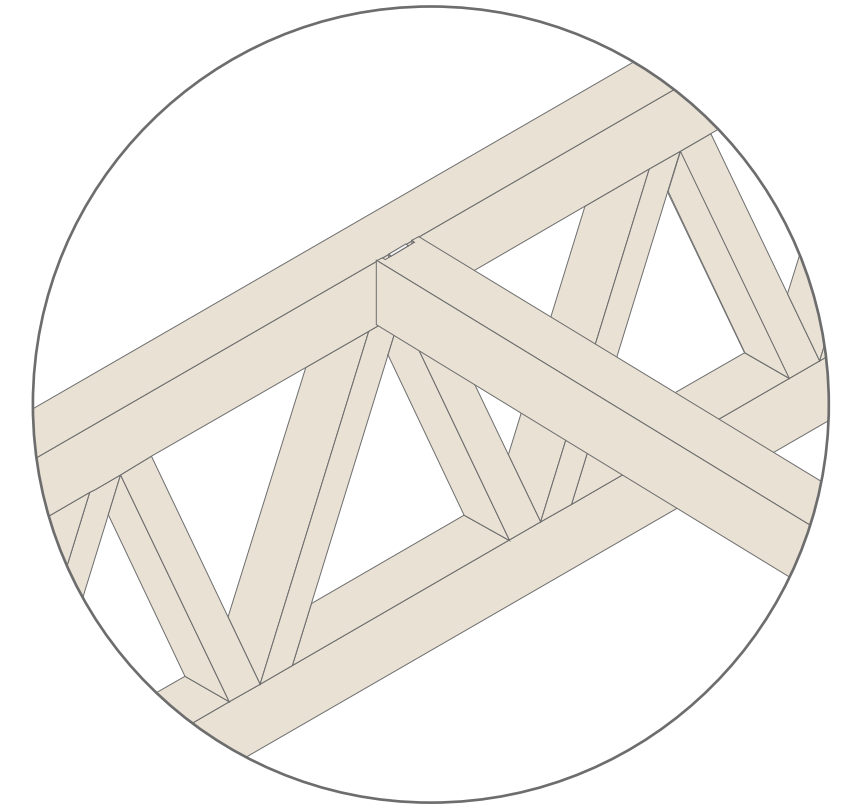
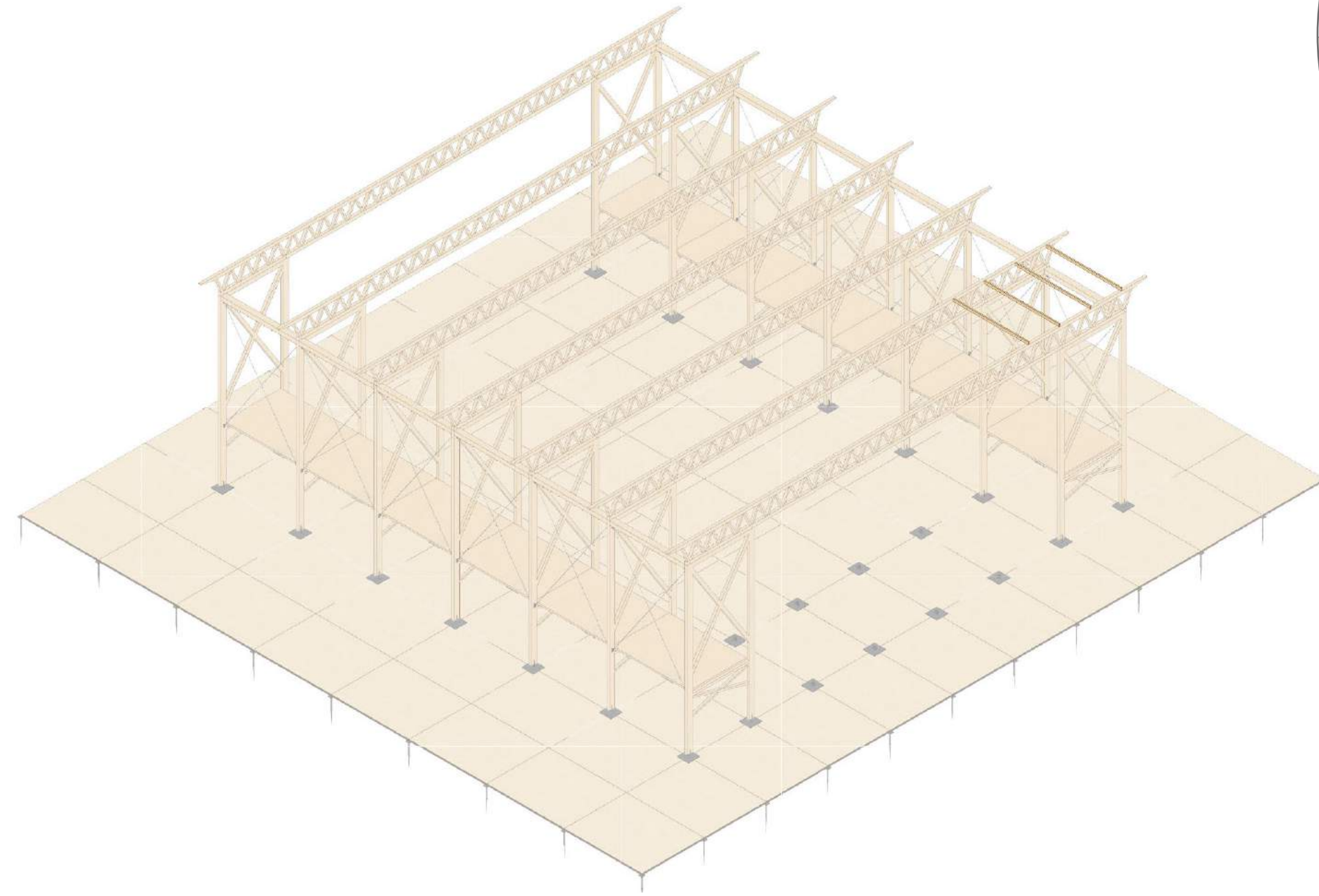

STEP 14

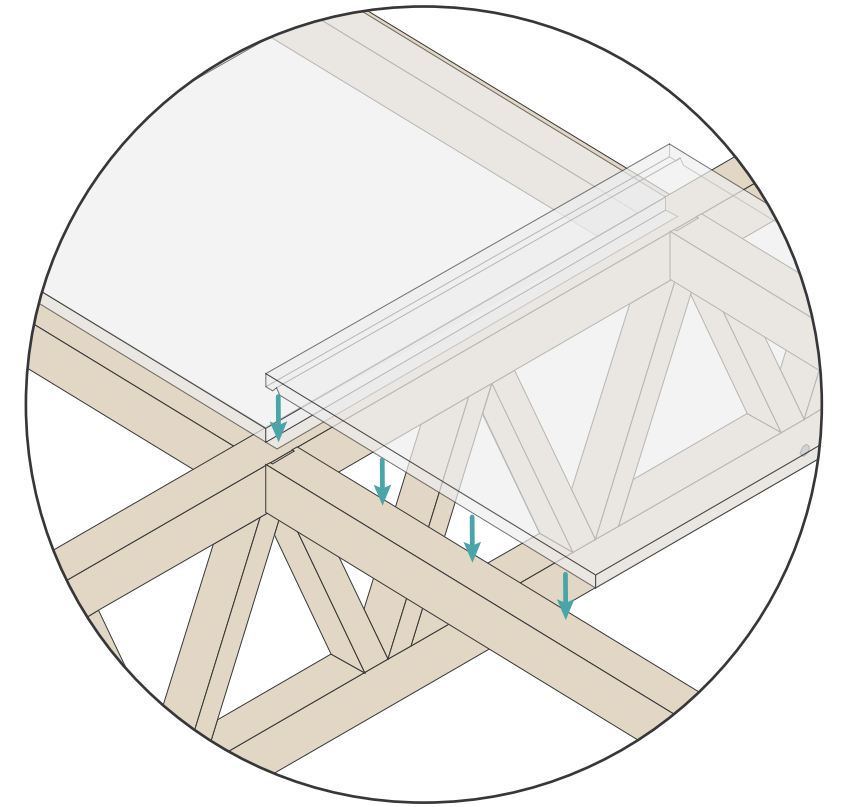
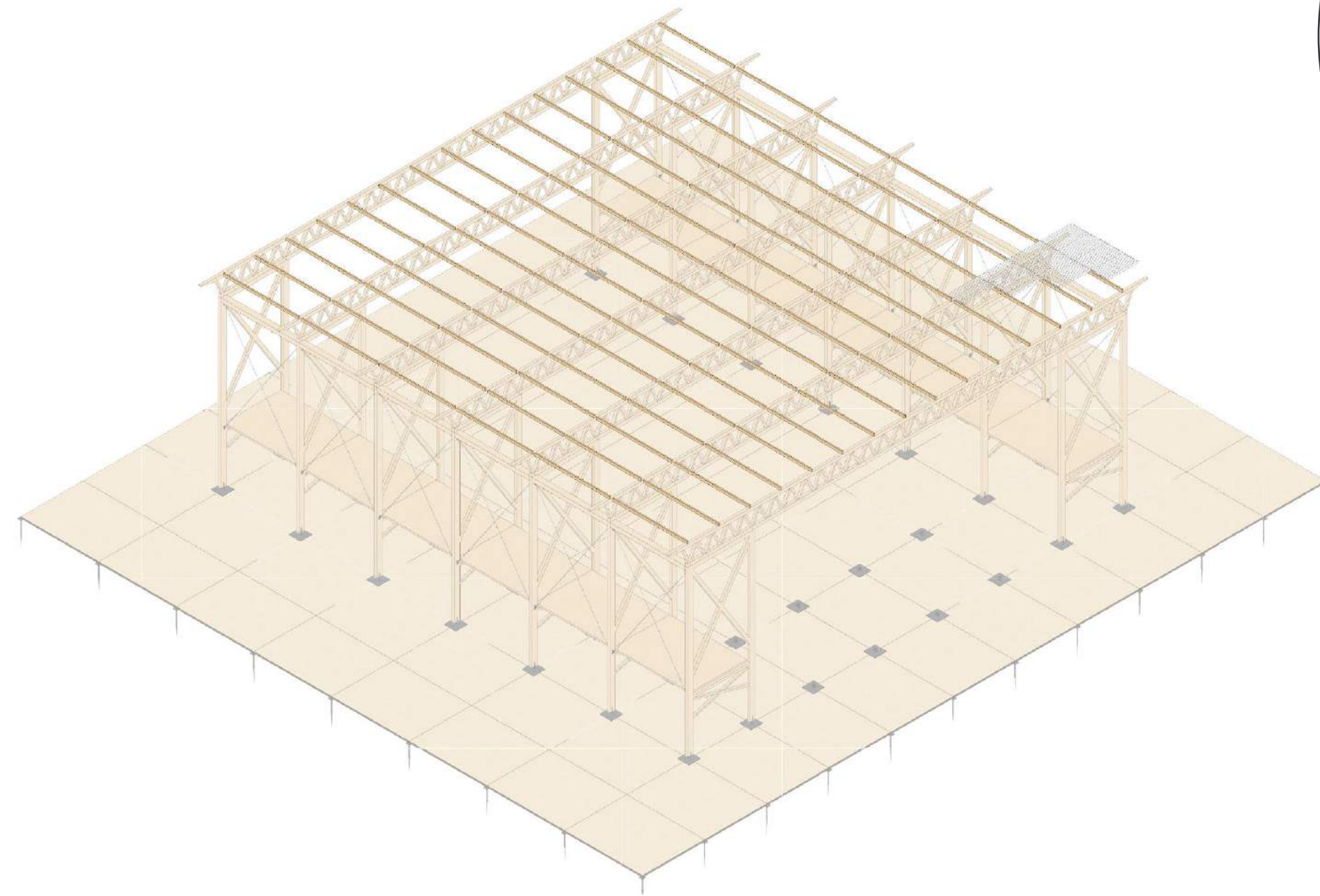

STEP 15

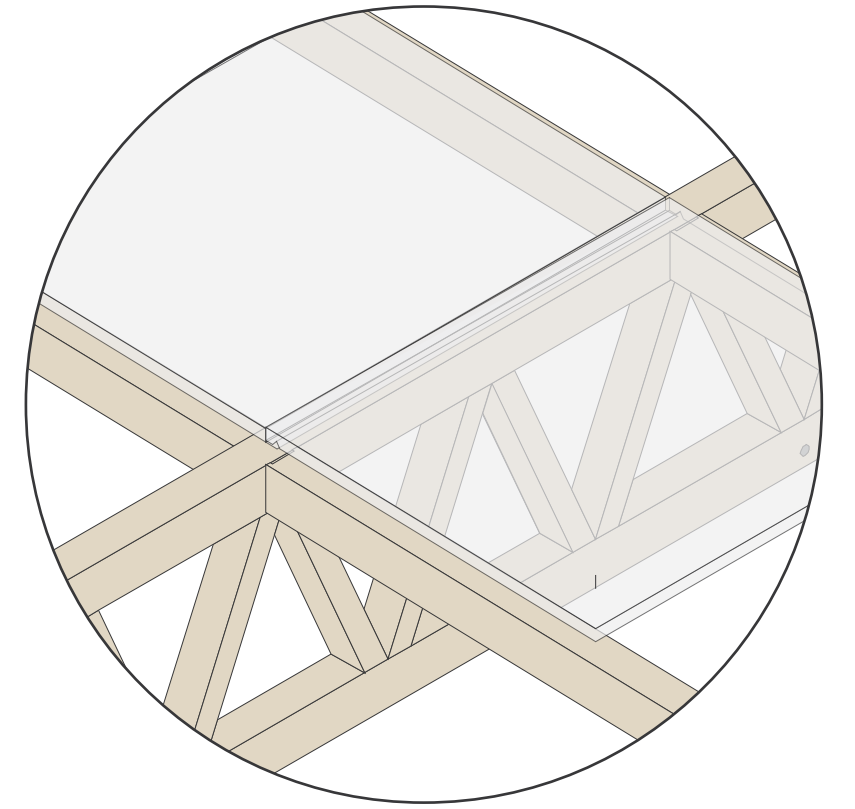
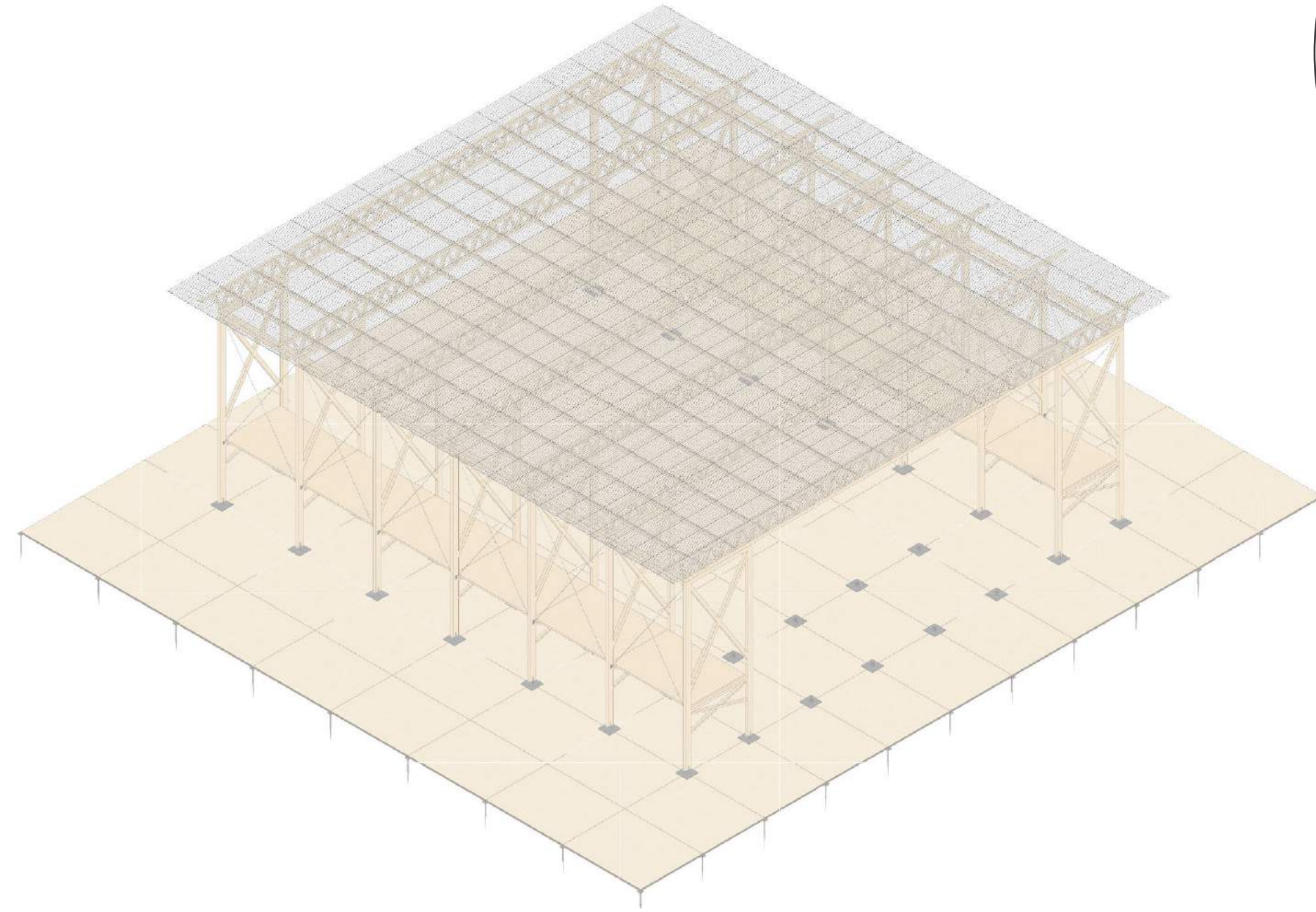

STEP 16

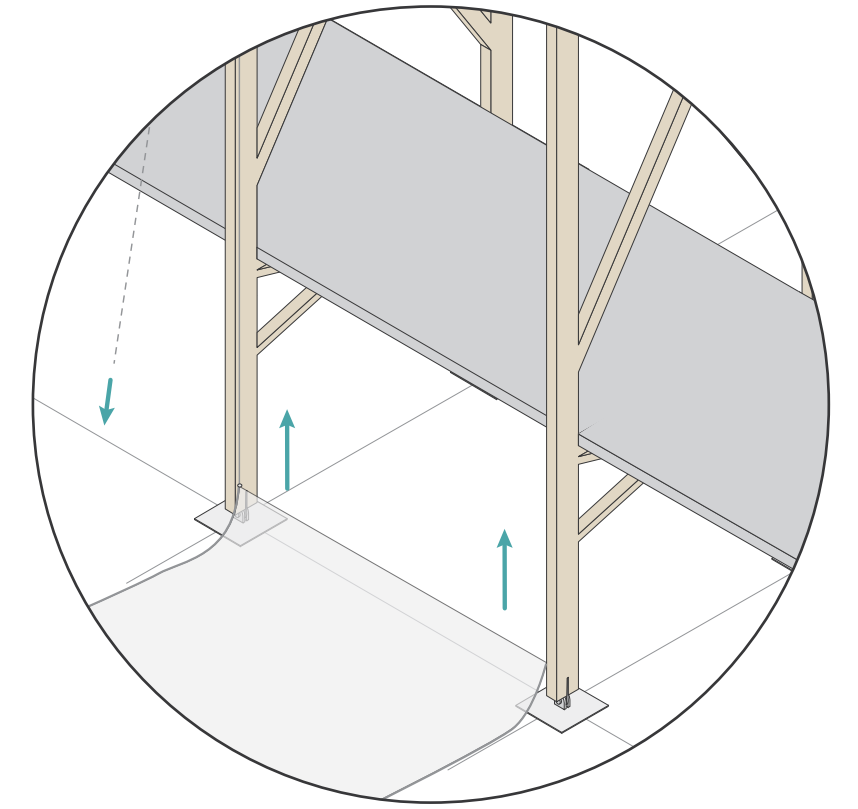
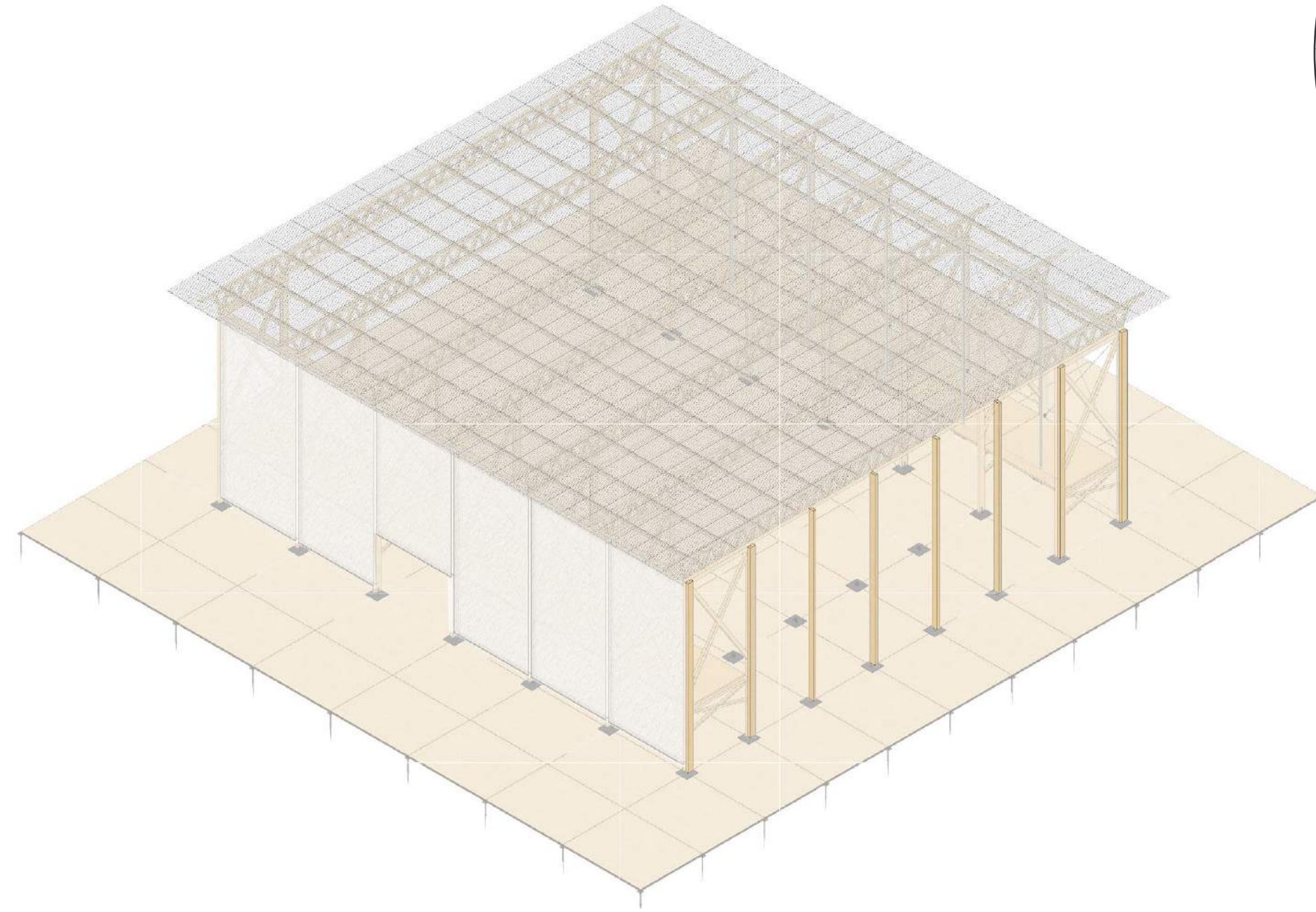

STEP 16

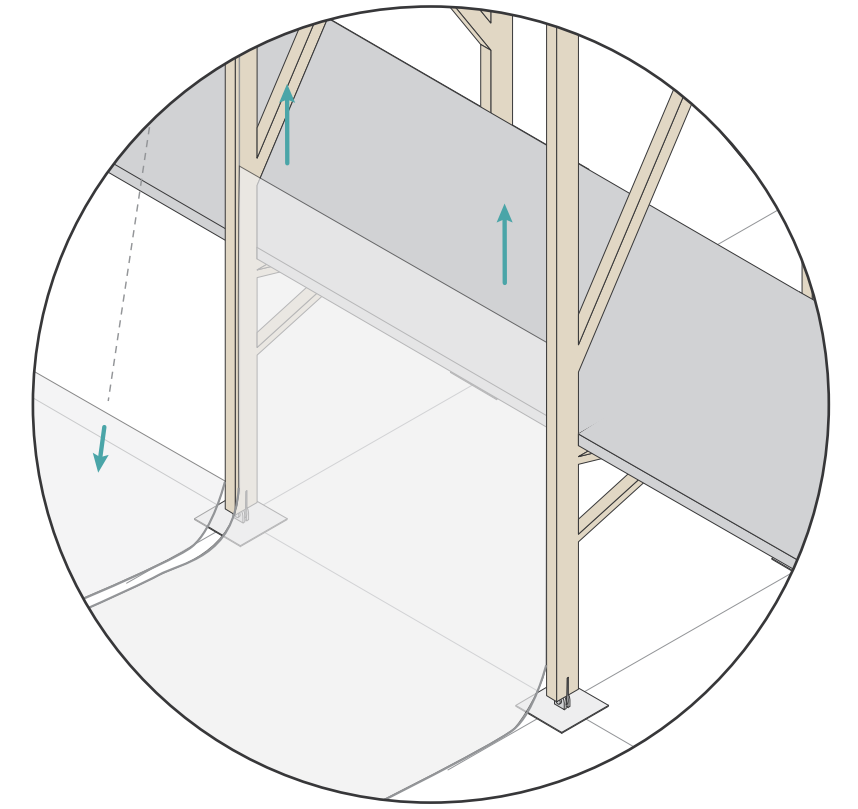
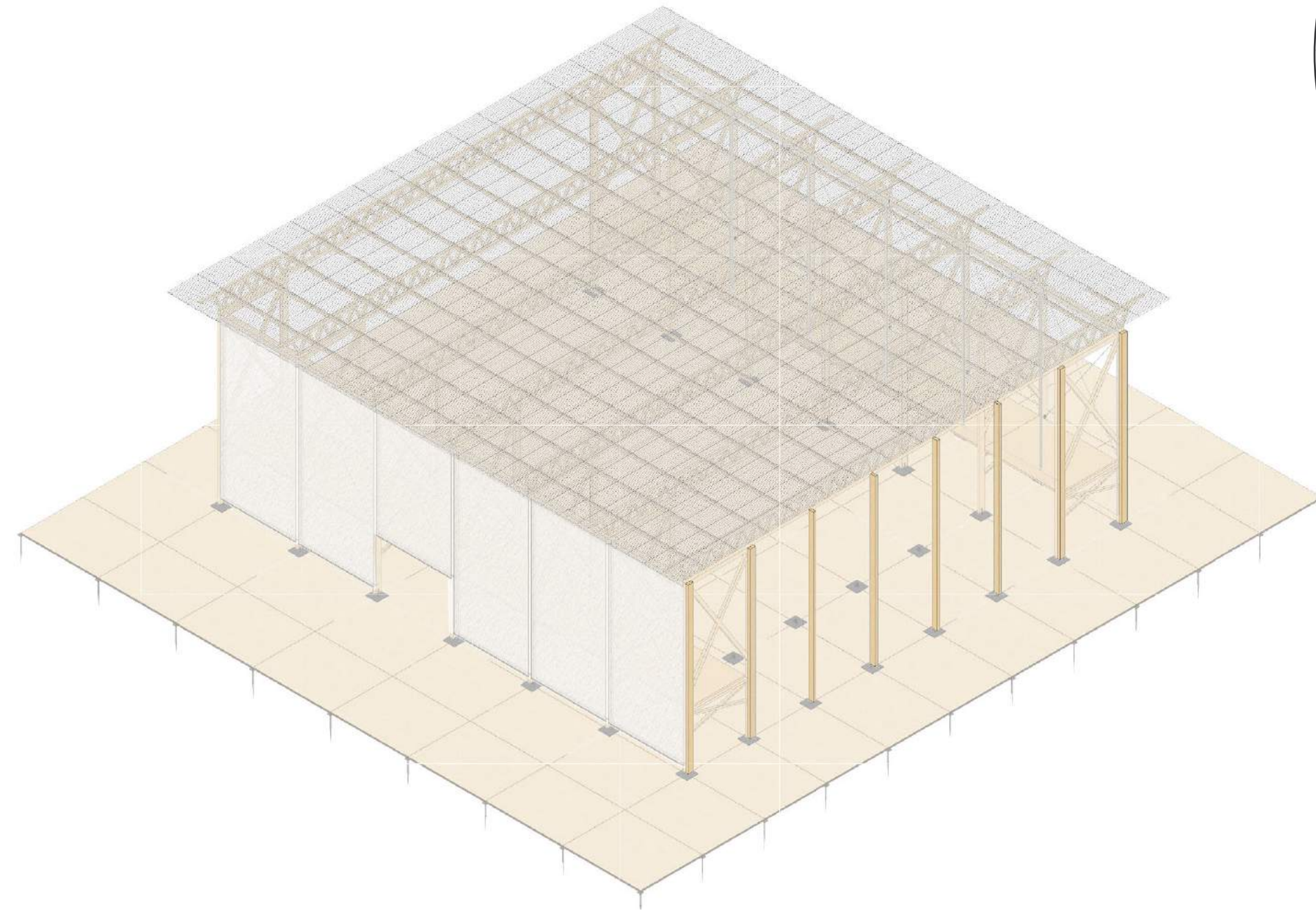

STEP 17

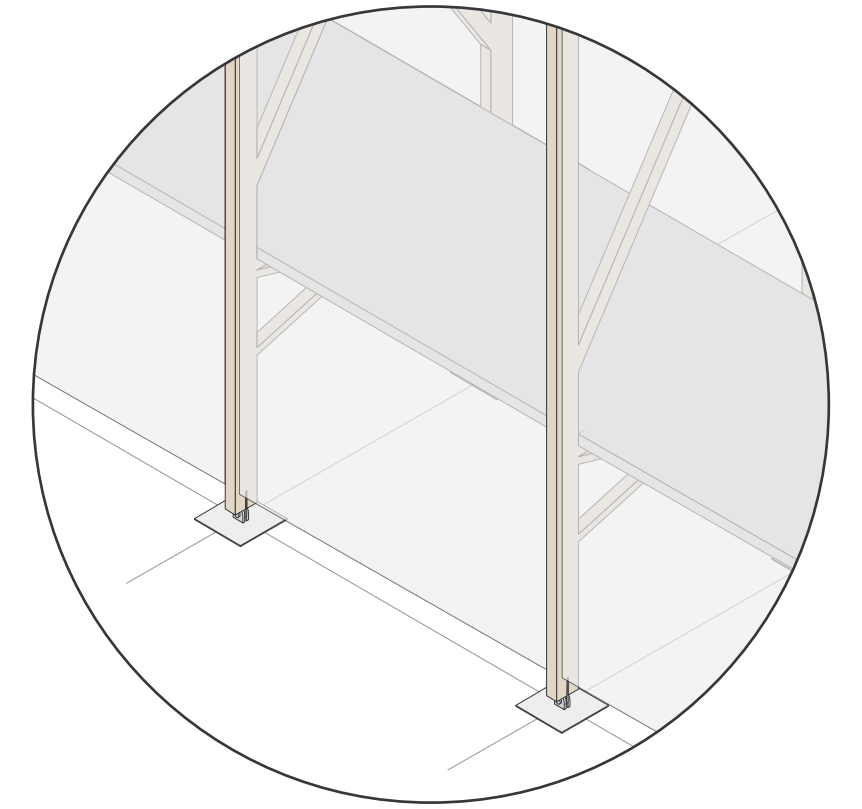
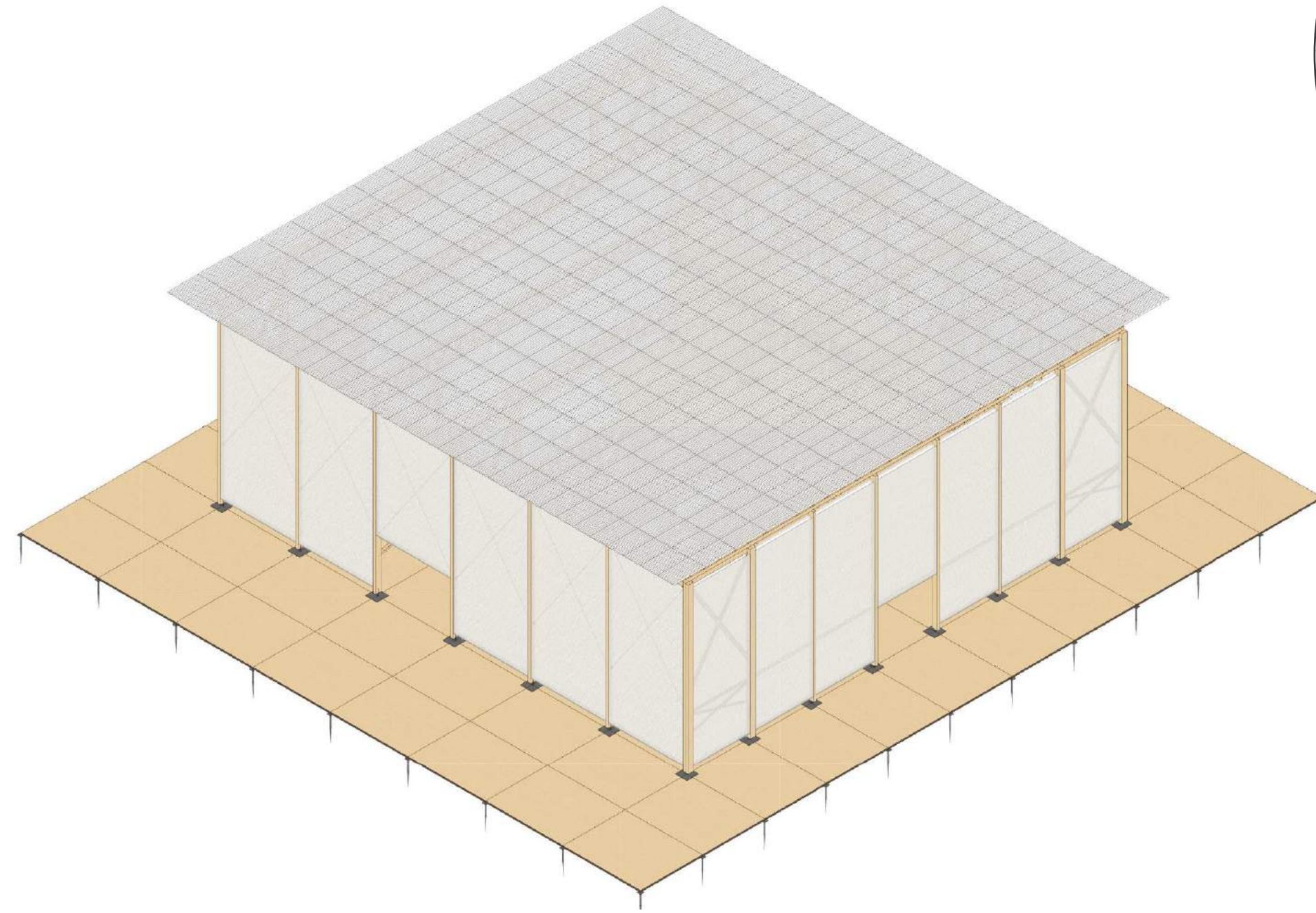

A wooden architectural model of a building's structure, featuring a central vertical column and several horizontal beams. Stylized human figures in various colors (blue, yellow, orange, red) are placed on different levels of the structure, suggesting a multi-story building. The background is a bright, overcast sky. The word "CONCLUSION" is centered in the middle of the image, flanked by two horizontal lines.

CONCLUSION

CONCLUSION



atmosphere



community

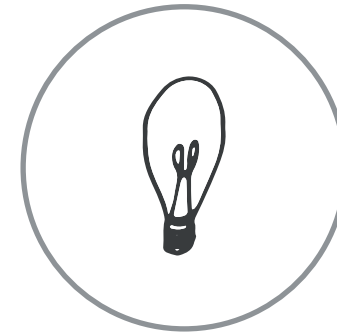

innovative

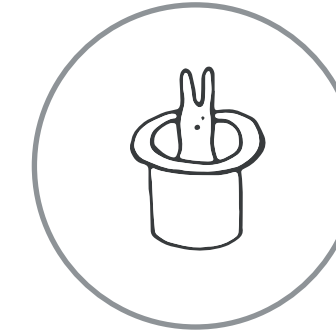

discover

CONCLUSION



PART OF THE PERFORMANCE



SOUND QUALITY

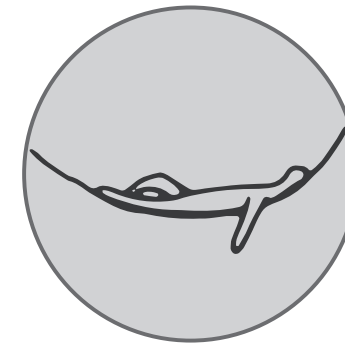

CAREFREE

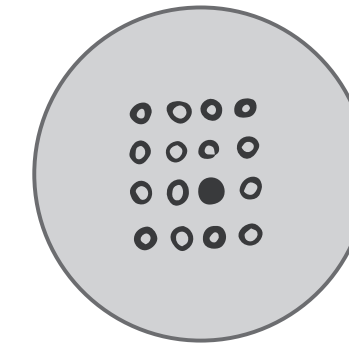

UNIQUENESS

CONCLUSION



PART OF THE PERFORMANCE

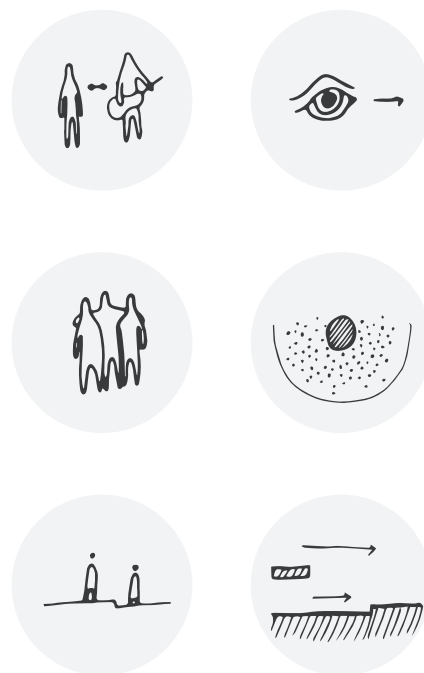

SOUND QUALITY

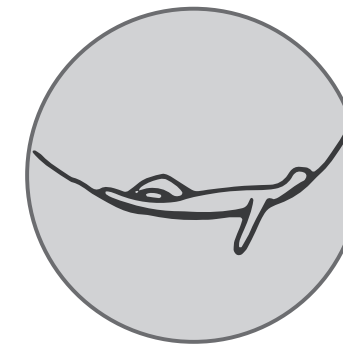
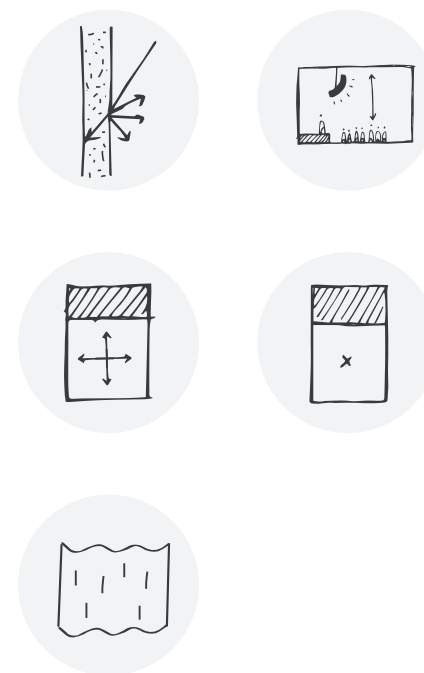

CAREFREE

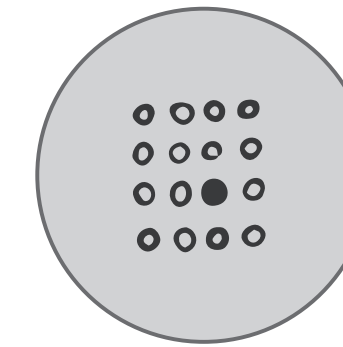

UNIQUENESS

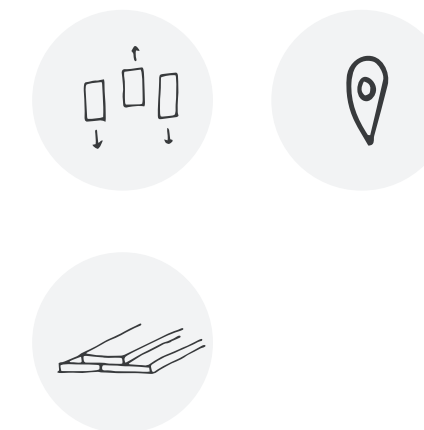

MULTIPLE USES

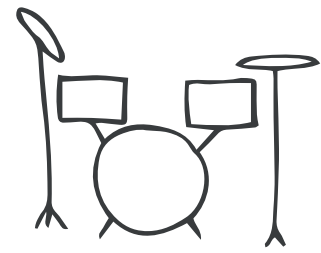

pop music

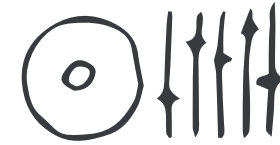

dance



theatre



classical music



jazz



lecture

MUSEUMPLEIN - AMSTERDAM



OEROL - TERSCHELLING



MARKT - DELFT



THANK YOU

THANK YOU

QUESTIONS?

