

# MONUMENTAL FOLLIES

AR3AP100

Public Buildings  
“The Music Marvel”

Date

*\_19-05-2022*

Student

*\_Phat Tran Ho*

*\_1211153*

Assessors

*\_Piero Medici*

*\_Sang Lee*

*\_Stefan Witteman*

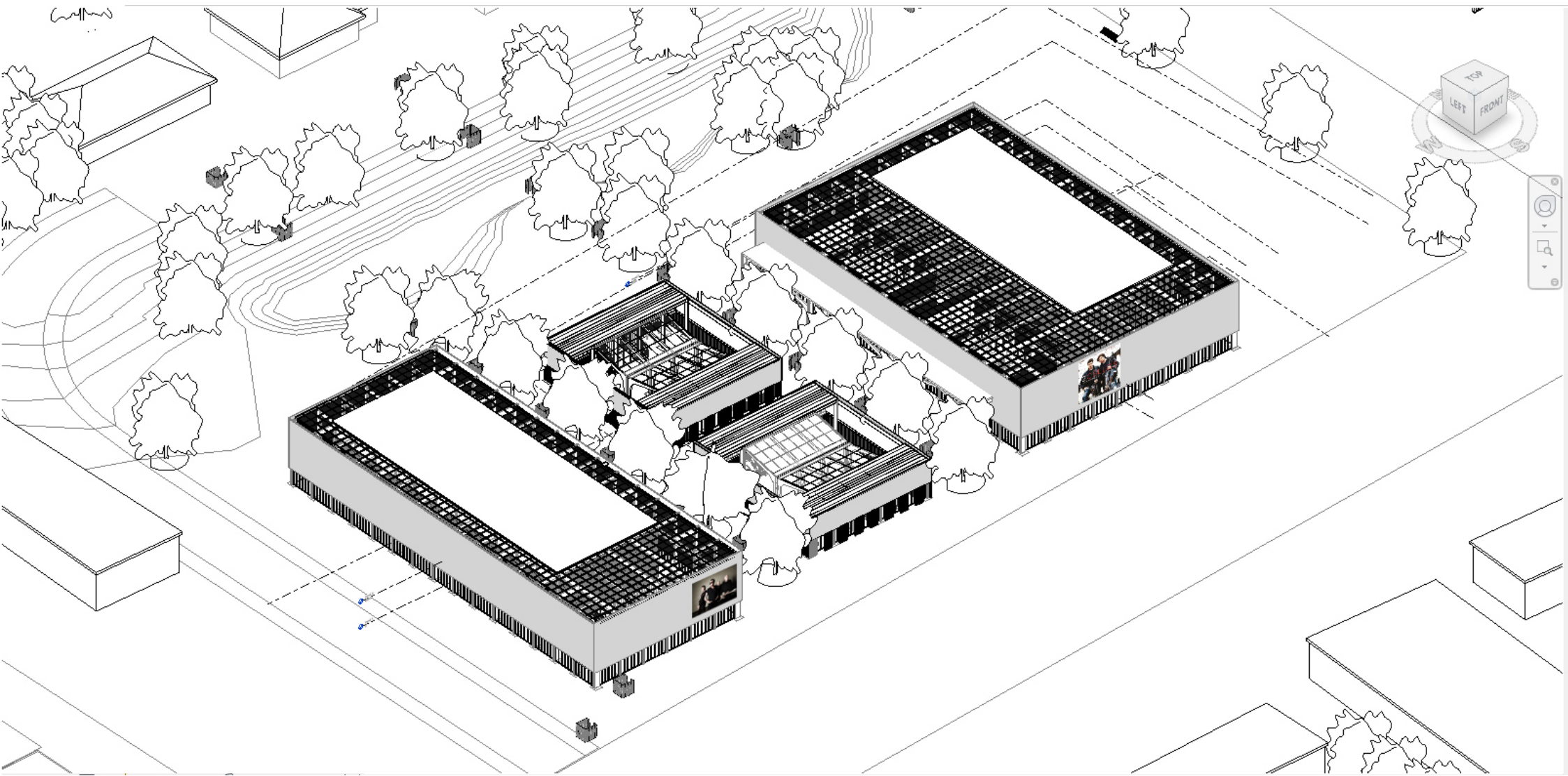

Monumental follies Birds Eye

# BINCKHORST

# Industrial Area Residential District

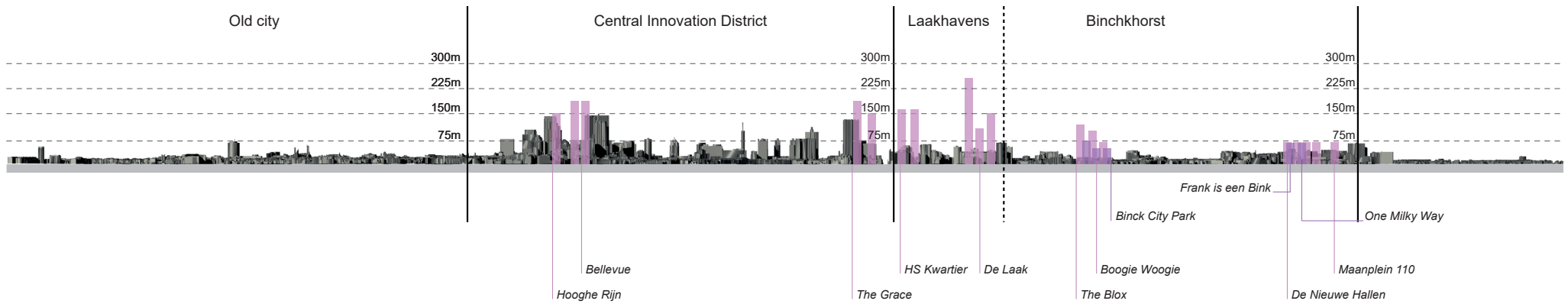

## RESEARCH QUESTION

“How can the Music Marvel, as a ***transformative intervention tool***, act as a ***cultural cohesive network*** for Binckhorst that utilizes the present ***historic artifacts***?”

# EARLY MANIFESTO



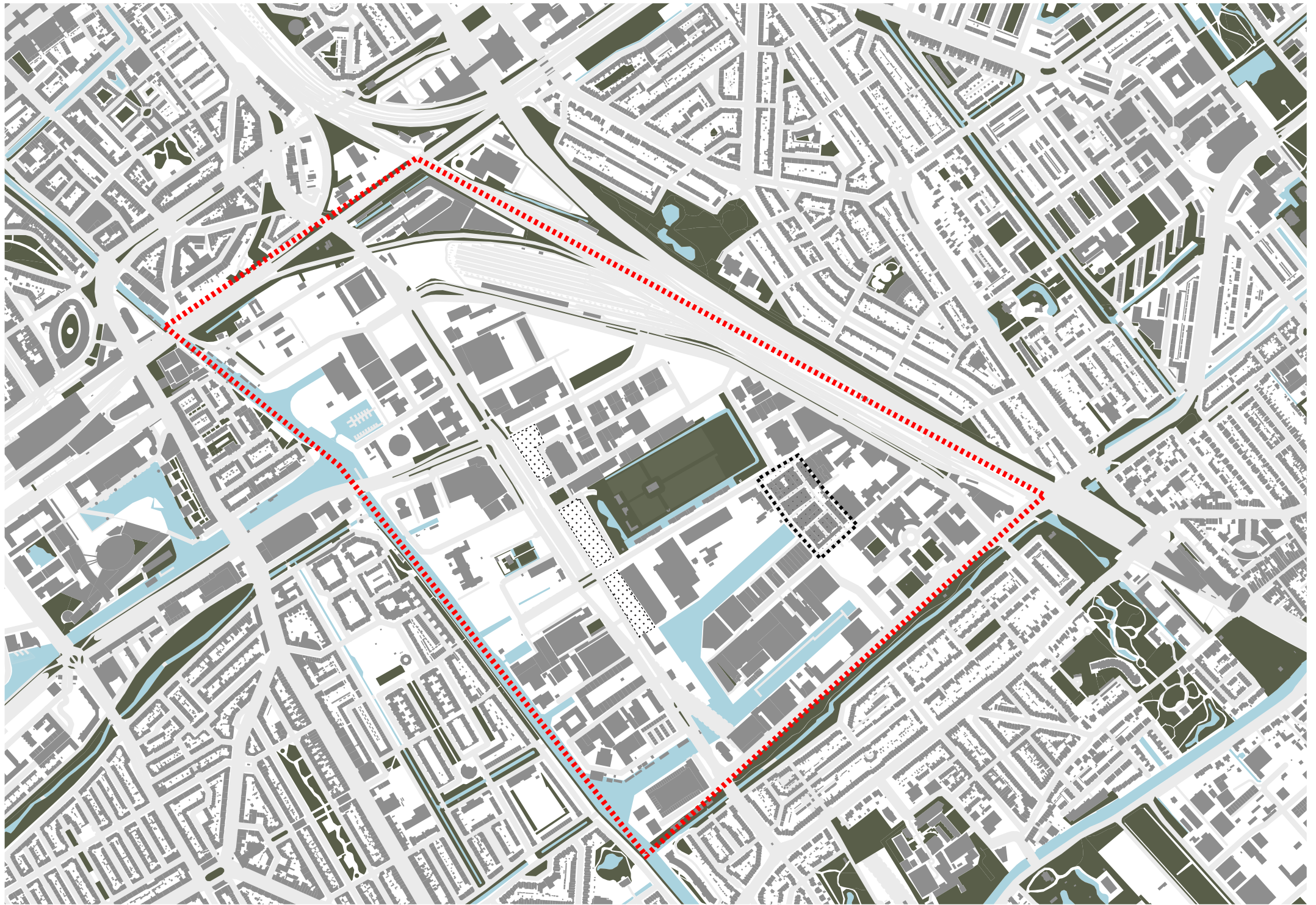



Industrial Auto Halls



Industrial Auto Halls



MEI ARCHITECTS



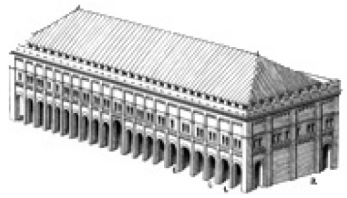

Original

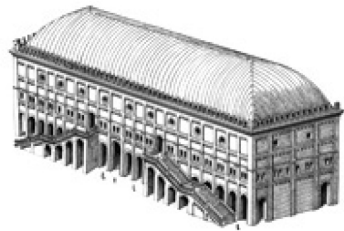

First change

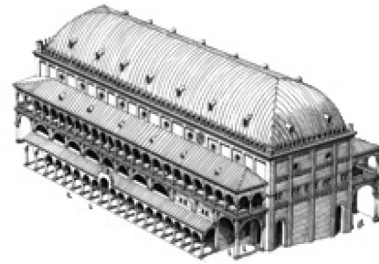

Second Change

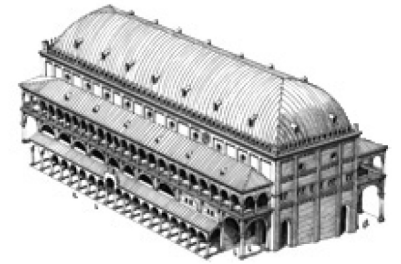

Present

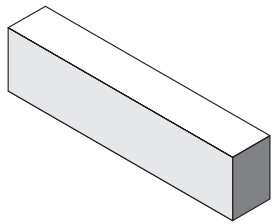

Original

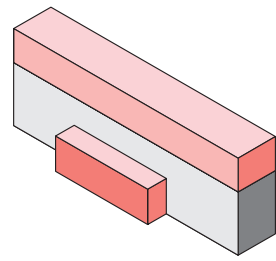

First change

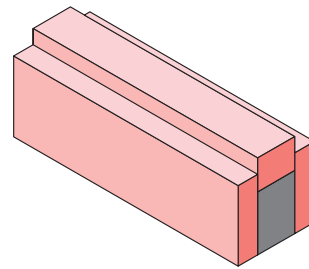

Second Change

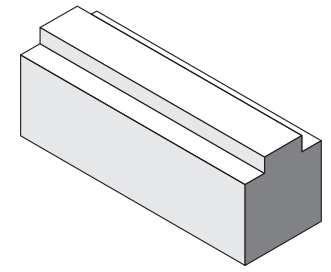

Present

Evolution is user experience

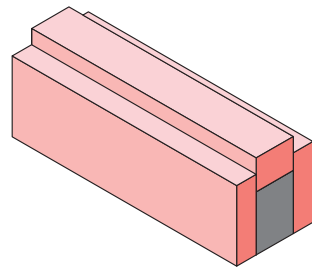

Present

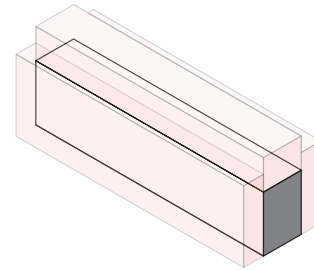

Existing

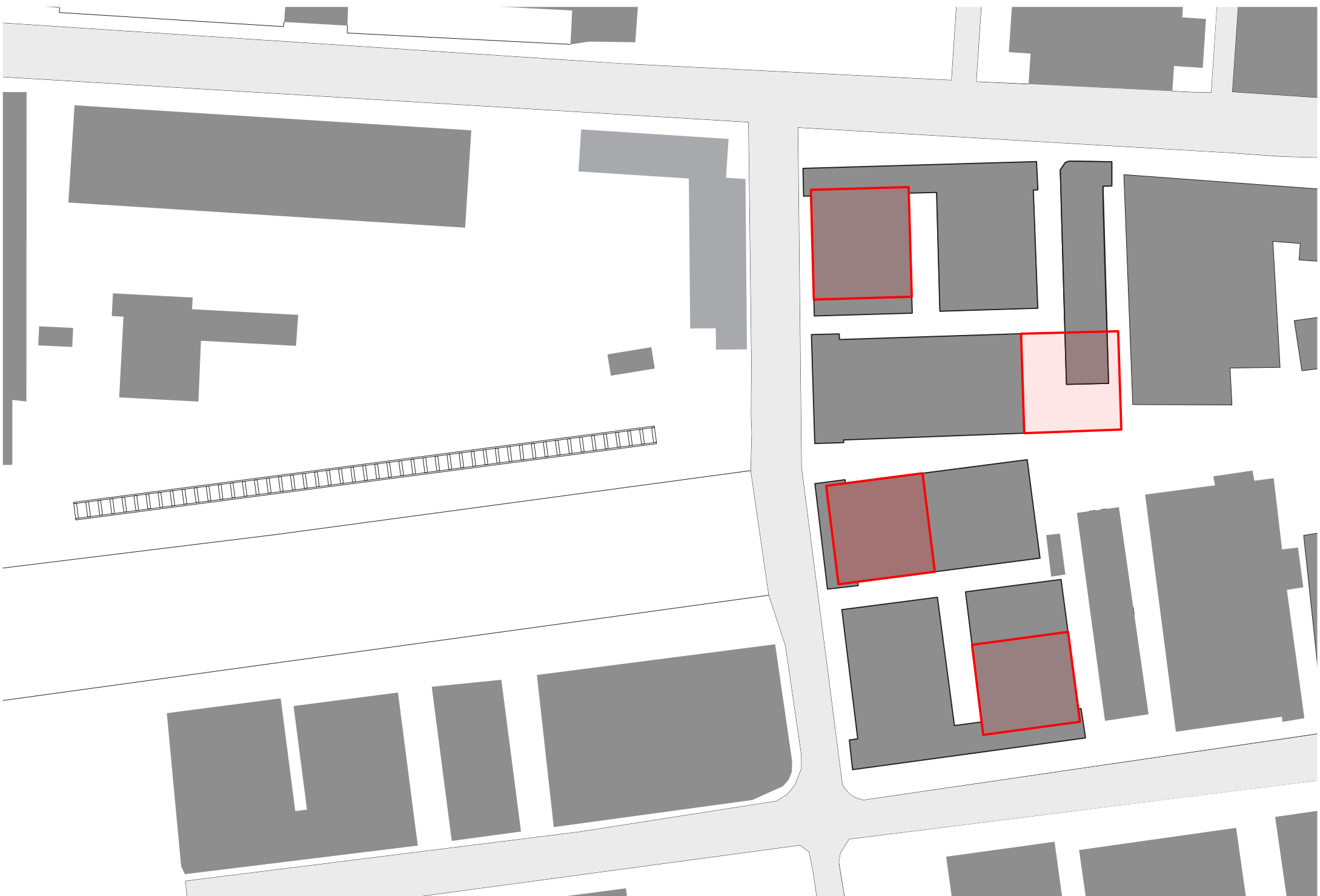

Footprint "De Nieuwe Hallen", MEI Architects

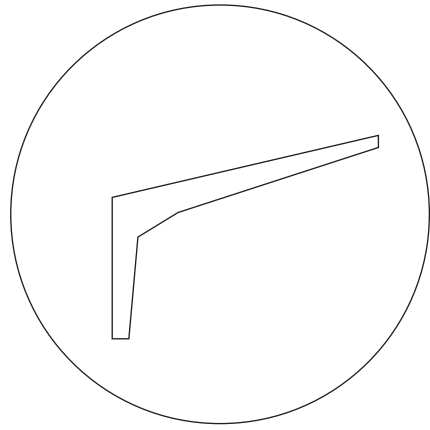

104



Consequences on existing structure

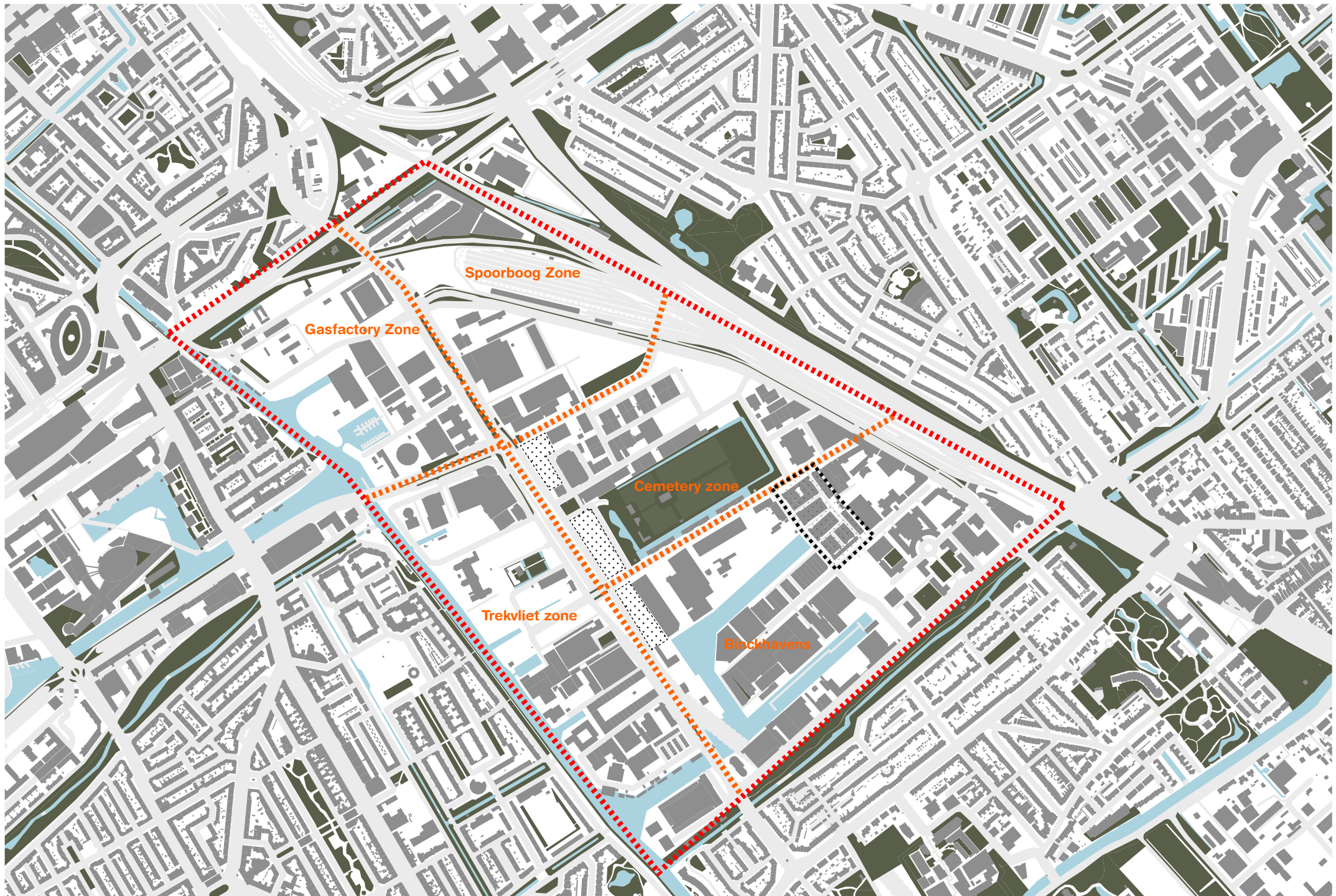

Defining best location

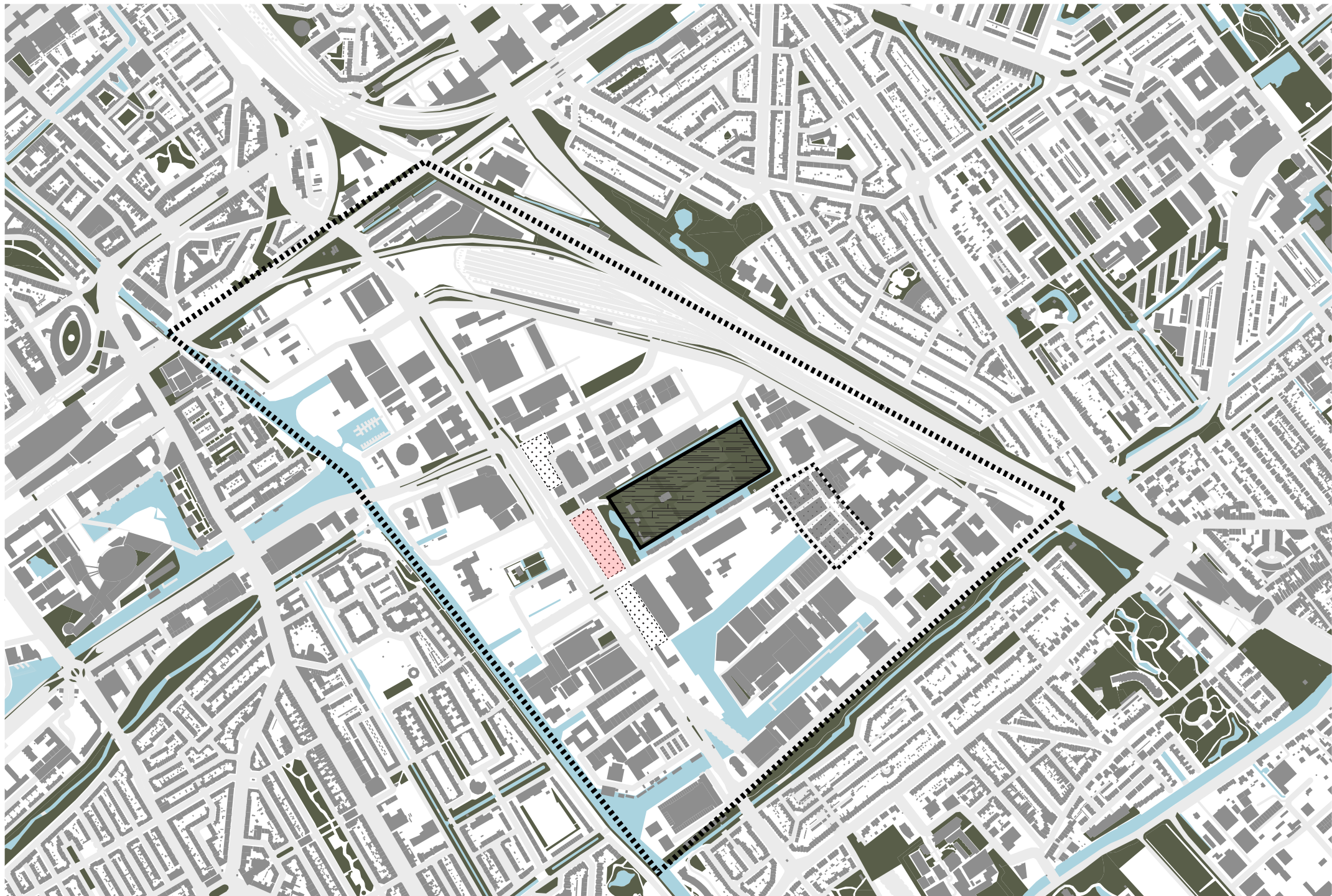



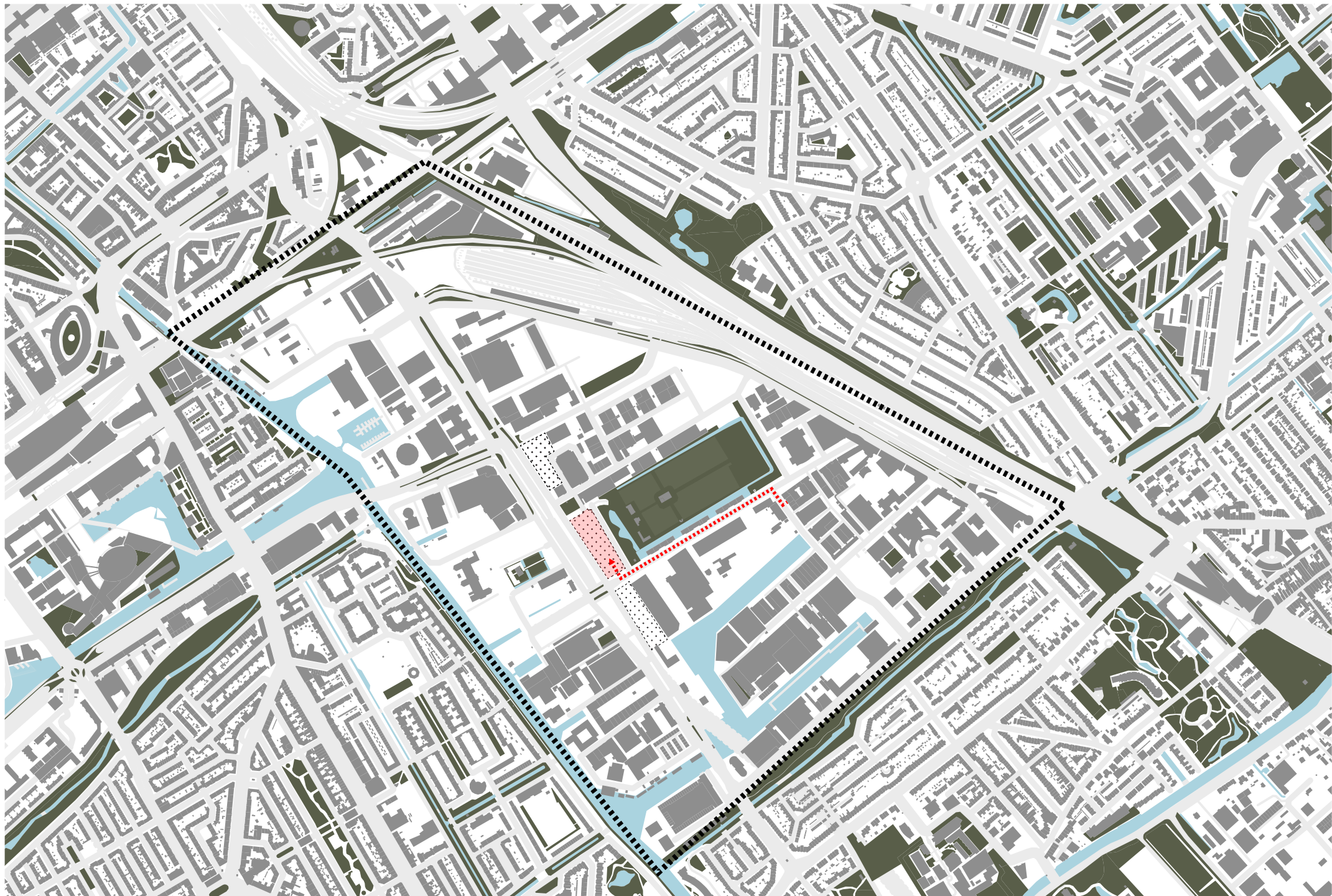

Relocation

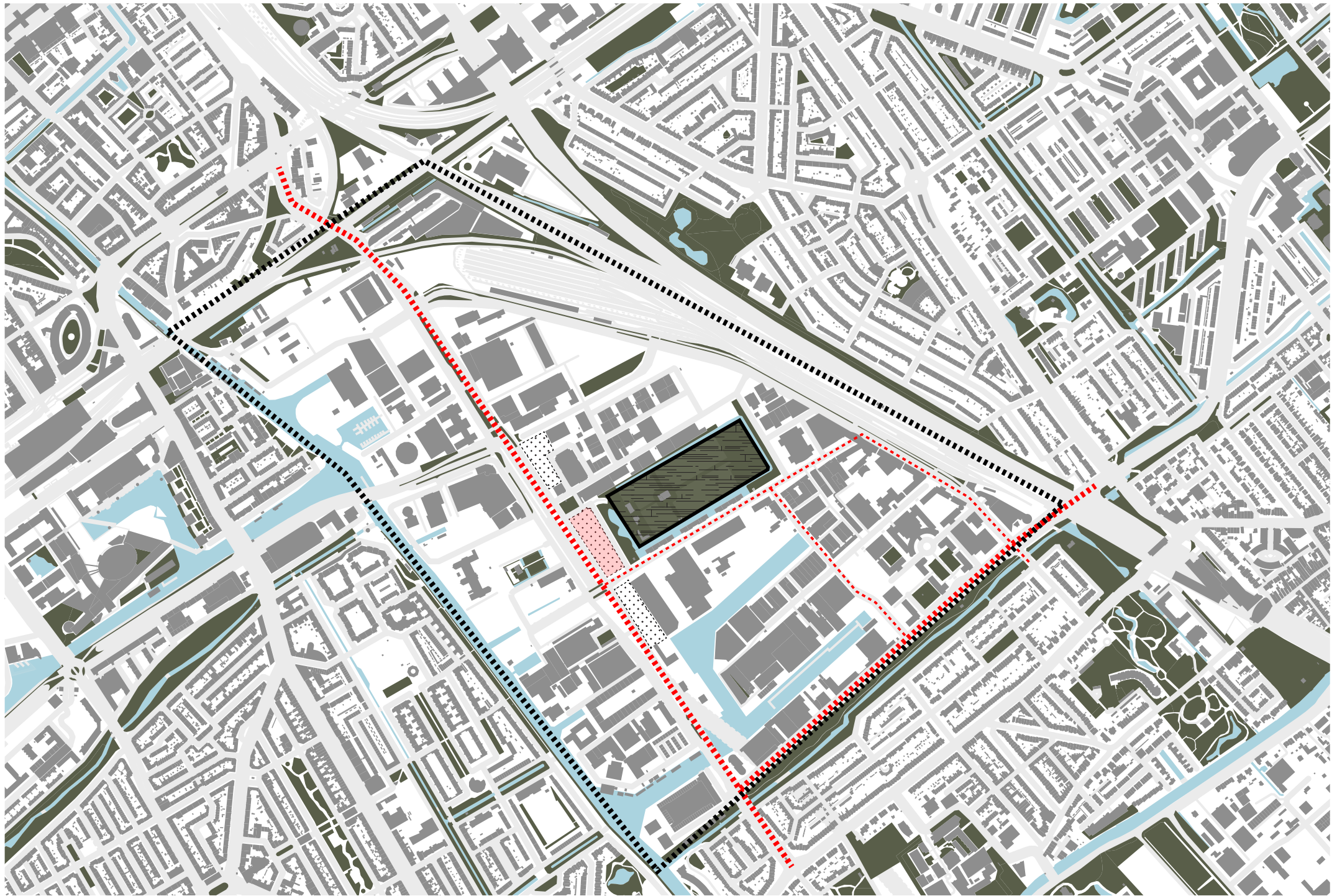

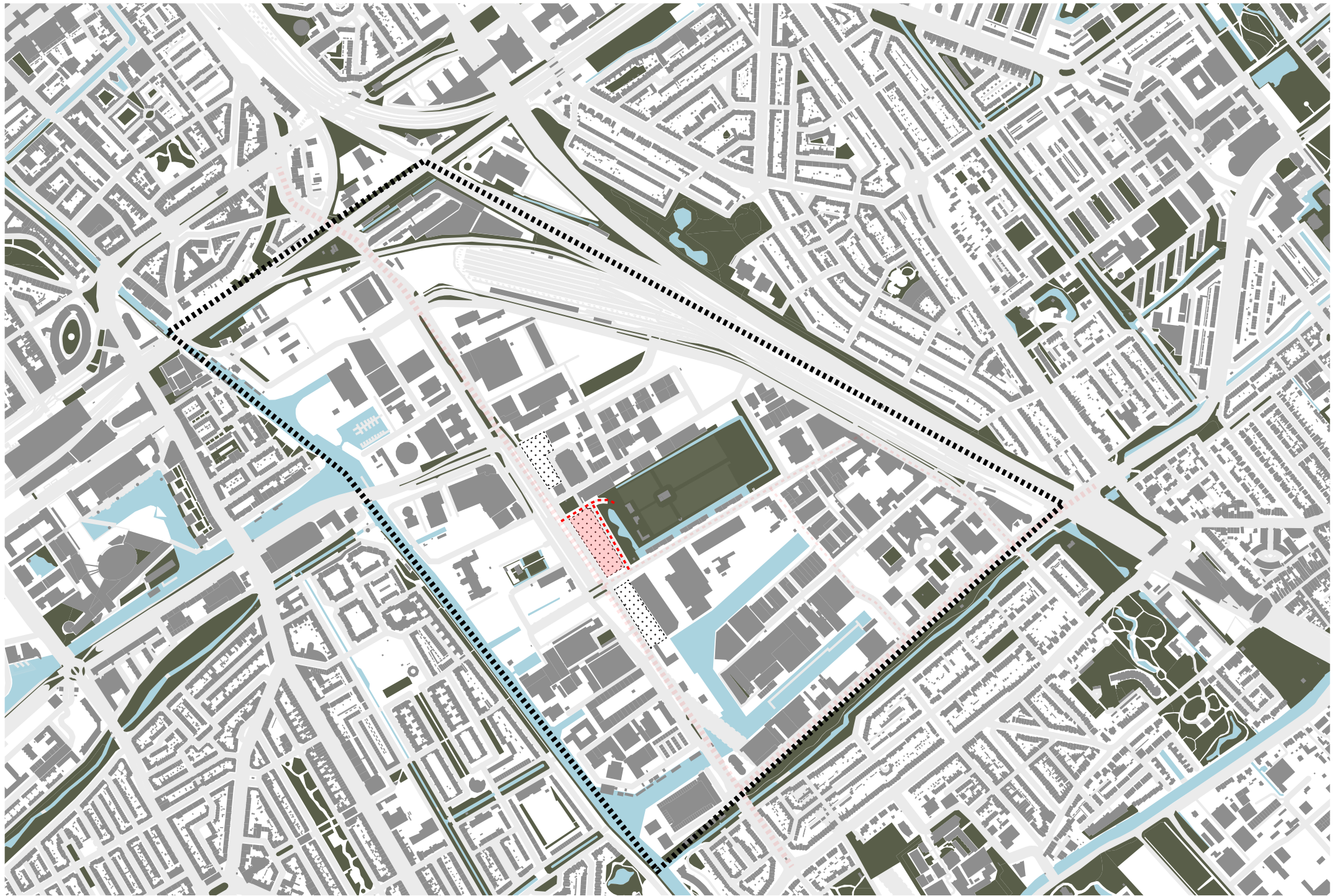

Attention points

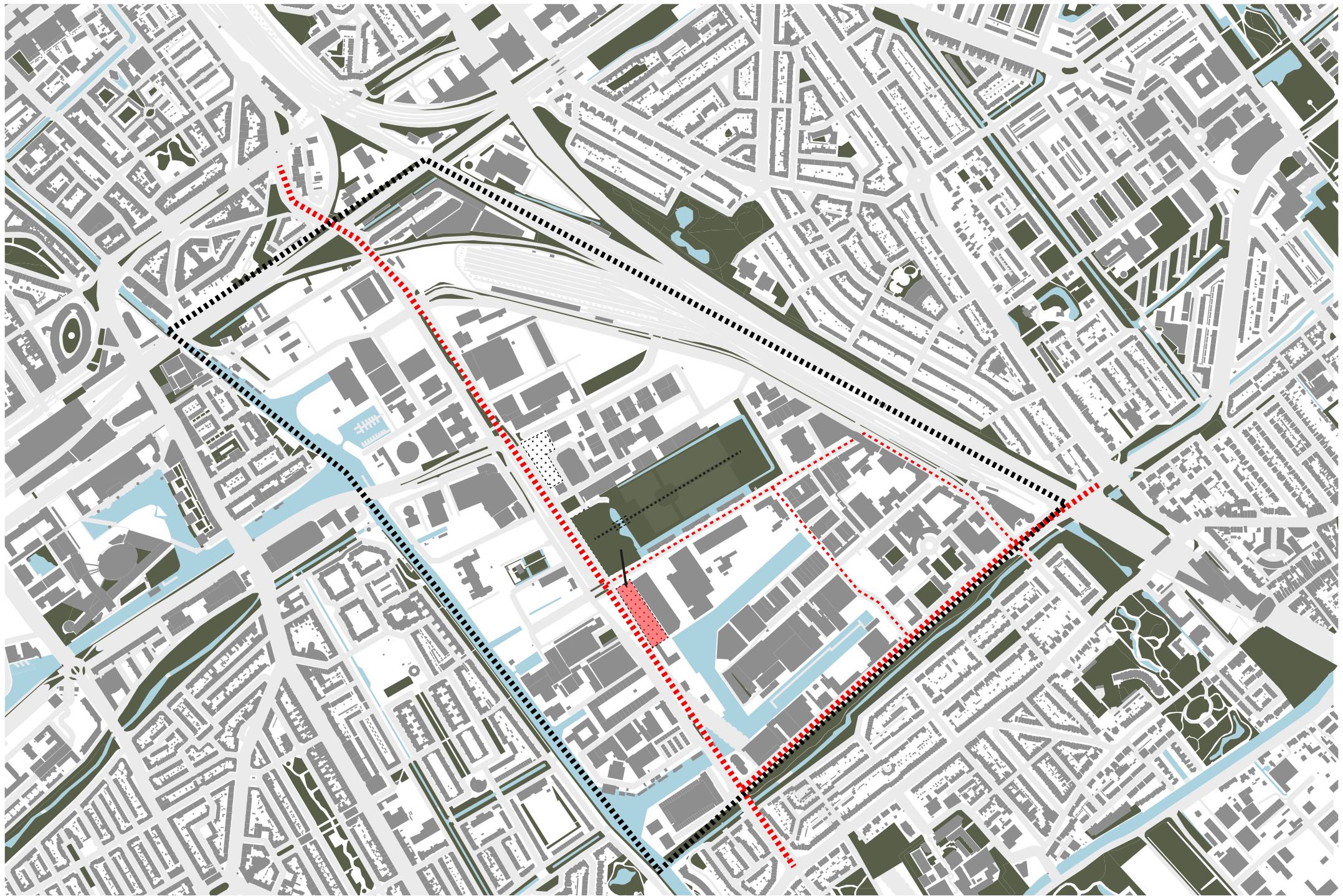

Changing Accessibility

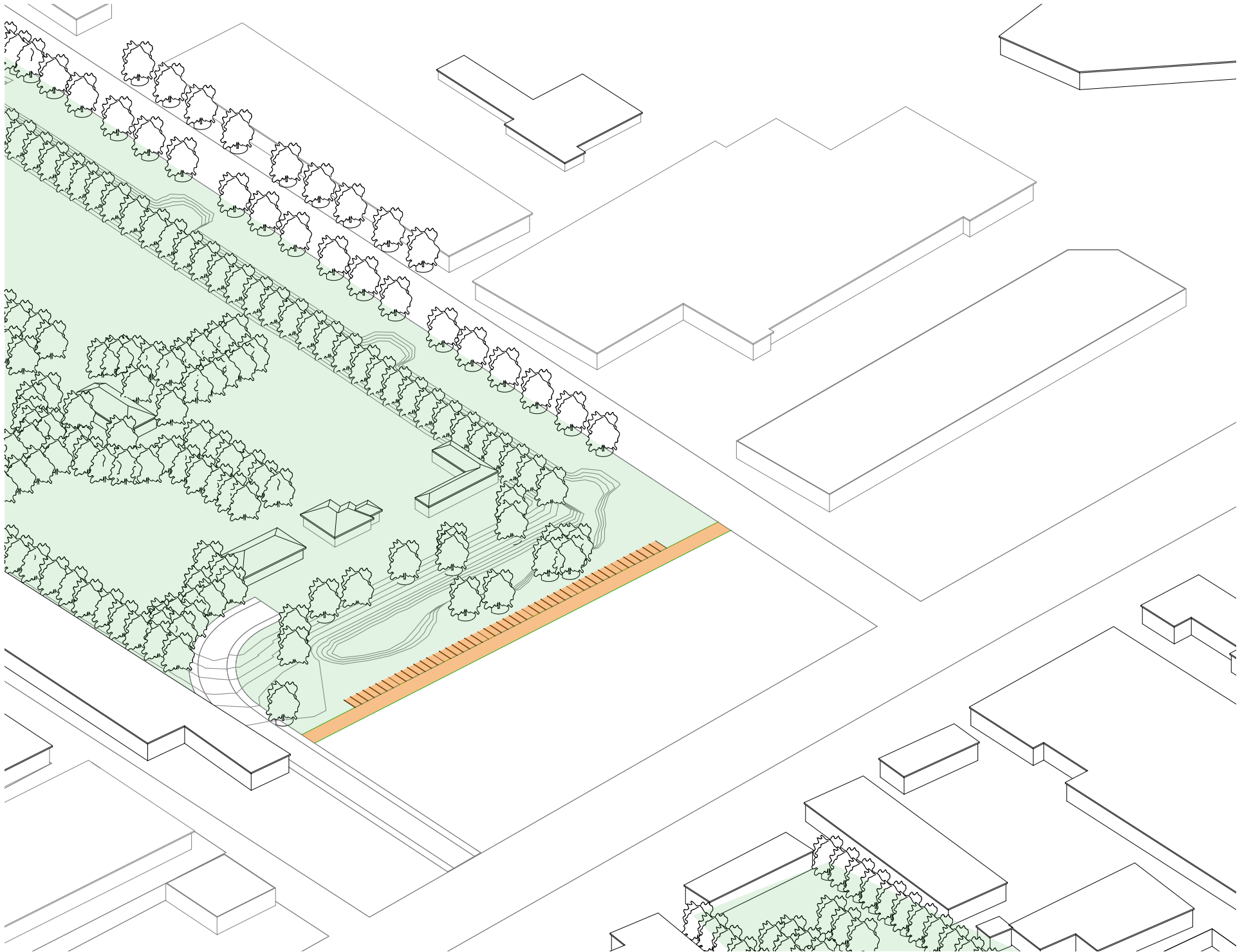

Connecting the Landscape

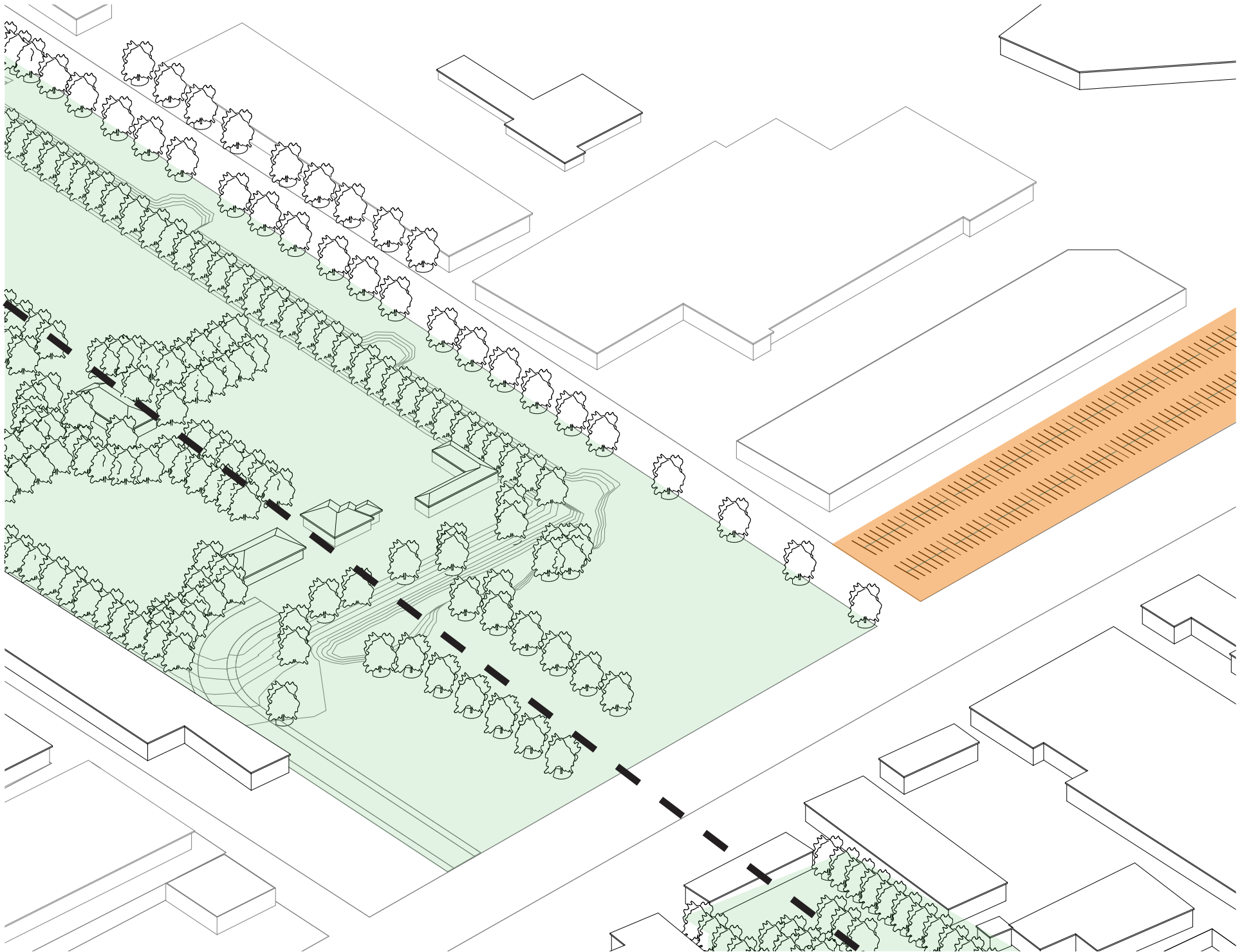

Relocating Road and Parking

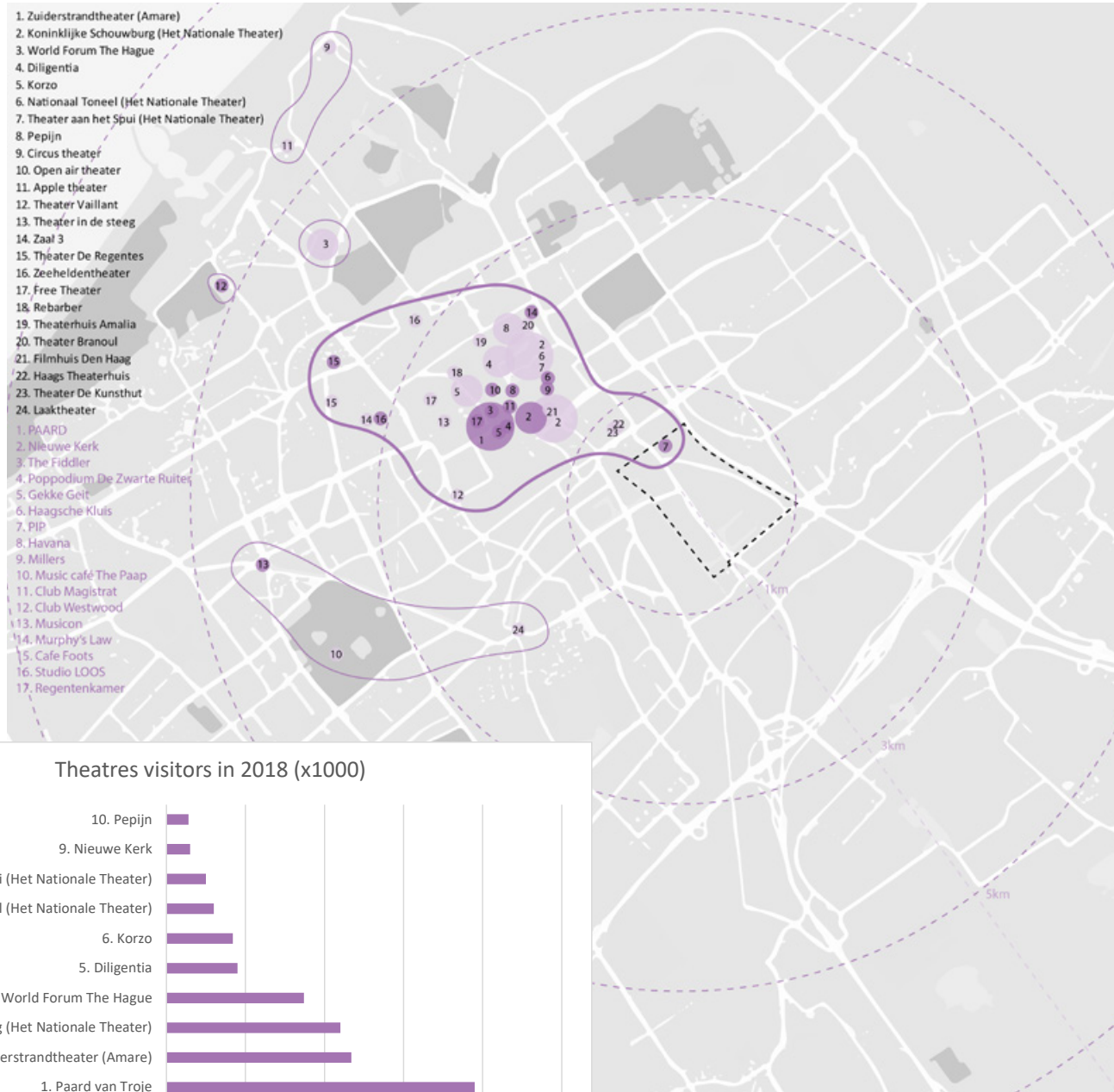

Classical music



Pop Rock music

Music in the Proximity

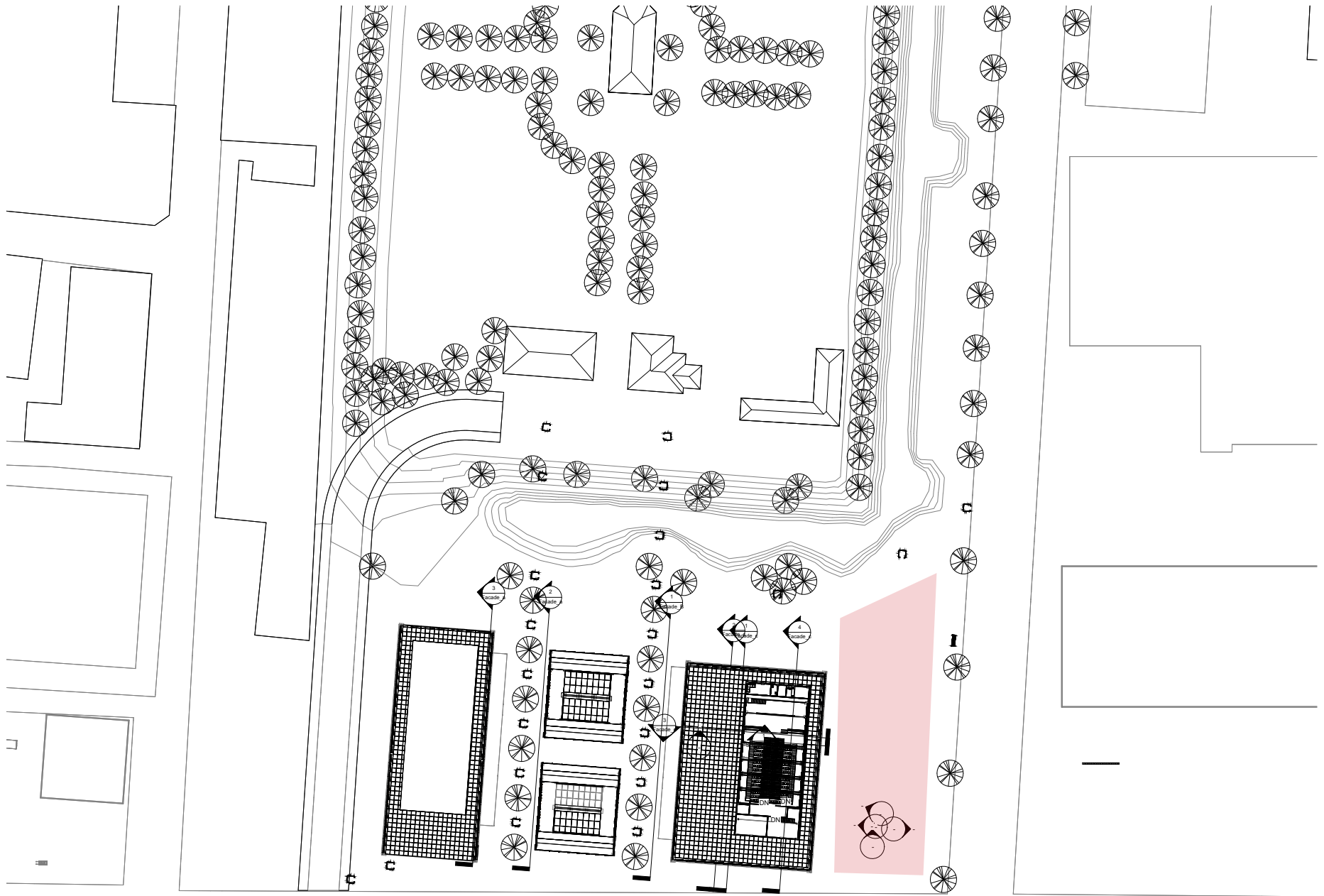

Parkplan





Zonweg

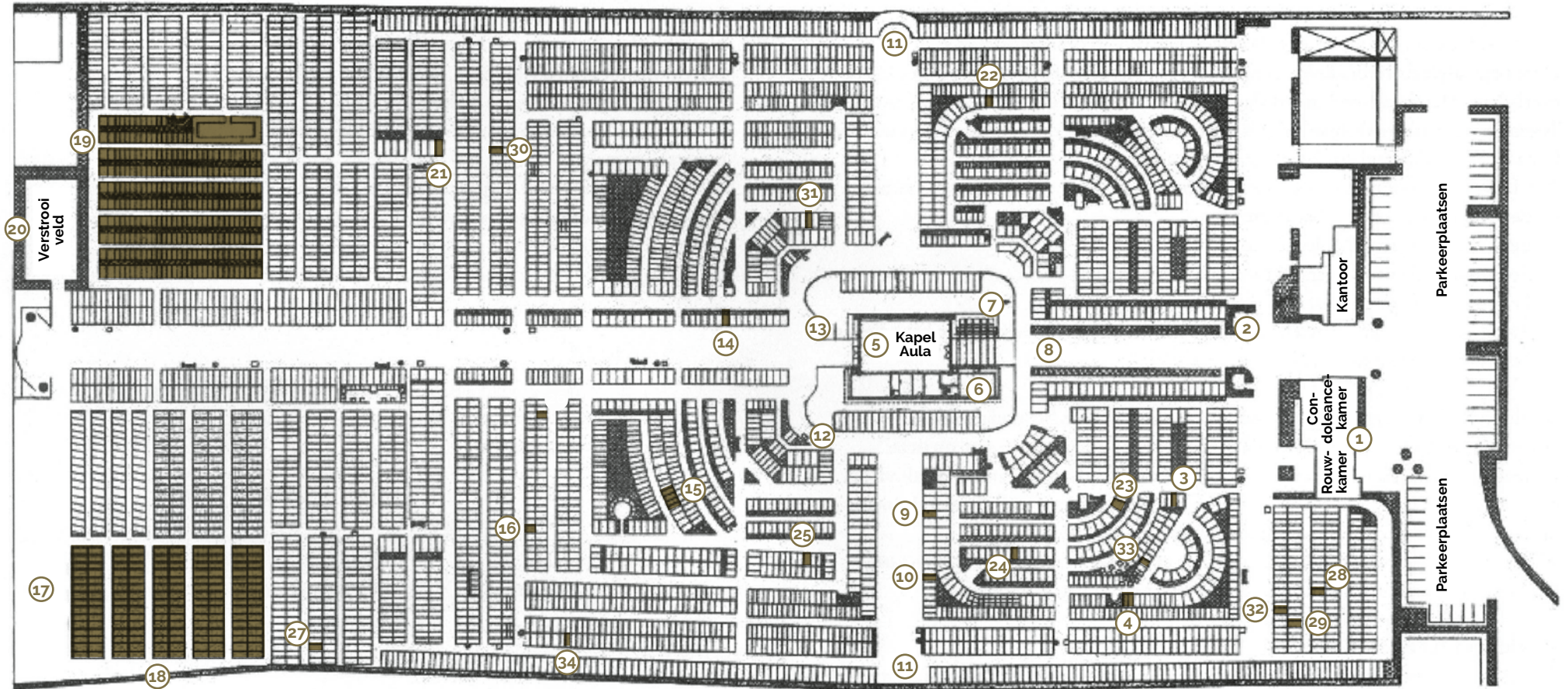

Wegastraat

■ Wandelroute

### Hiking Route Cemetery

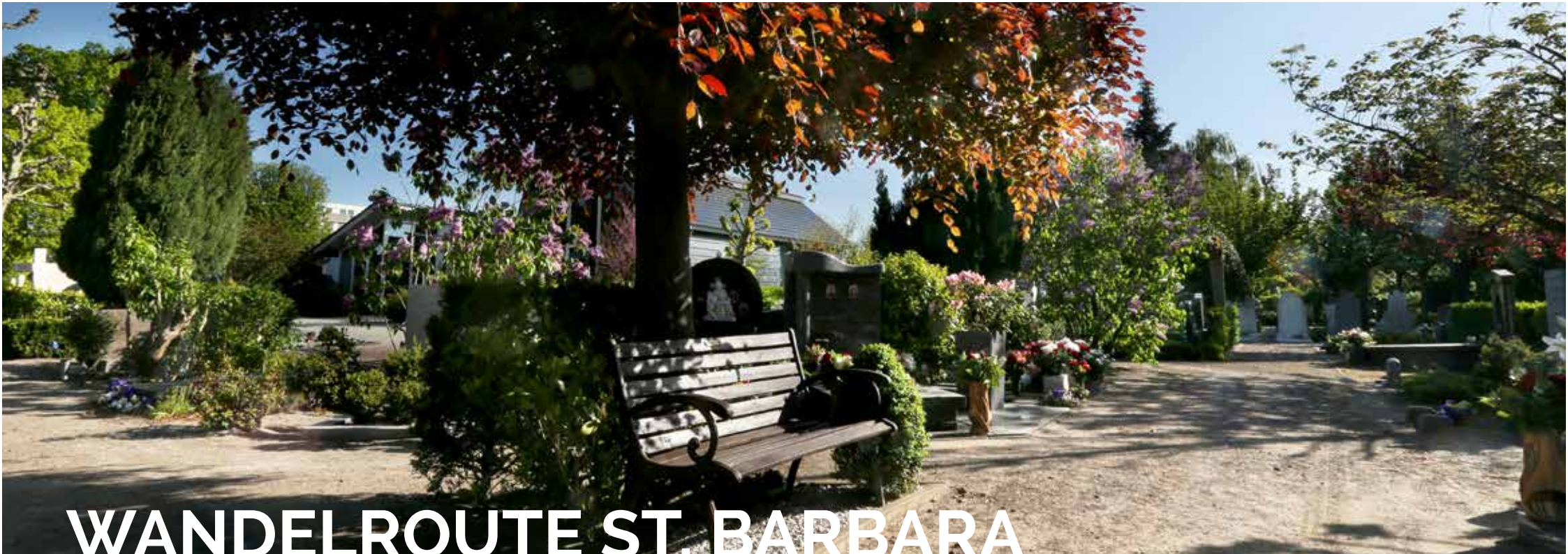

# WANDELROUTE ST. BARBARA

In de glorie tijd van het Nederlands Danstheater maakte hij twintig jaar lang de decors en kostuums. Ze worden tot op de dag van vandaag nog steeds gebruikt. Op de begrafenis nam de Haagse Kunstwereld op St. Barbara op grootse wijze afscheid van hem.

## 31 | Jo Hendrichs (verzetsstrijdster)

grafnummer: 429 D

1907 - 1986

In Den Haag is de straat Jo Hendrichs laan naar haar vernoemd. Van maart tot september 1940 reist ze af naar het voormalige front van de Fins-Russische winteroorlog om gewonde militairen te verzorgen. Op de terugreis neemt ze het besluit in het verzet te gaan. Ze regelt voor patiënten geld, valse papieren en onderduikadressen. Als er geen plek is voor de Hongaar Andor Kaszó neemt ze hem mee naar huis. Ze worden verliefd en Jo raakt zwanger van Minka.

Het gedicht op pagina 22 is geschreven door dochter Minka Kaszó.

## 32 | Orlando Jakobus

grafnummer: 17 Z

1956 - 2020

Orlando is uitgeroepen tot de beste conciërge van Den Haag en Nederland. Deze

uitreiking werd groot gevierd door D66 en de wethouder van Den Haag. Hij werkte op de Carolusschool. Tevens zijn er op internet filmpjes te vinden o.a. met zijn grote idool Louis van Gaal bij TV programma Puur Geluk. Als Corona het toelaat wordt er ook een straat naar hem vernoemd.

## 33 | Johannes (Jan) van den Berg

grafnummer: 354 A

Jan stond bekend als icoon van het Haagse marktlevens. Het ambulante karakter van de handel op de markt was hem op het lijf geschreven. Er was niets wat hij niet kon verkopen. Op enig moment is hij zelfs uitgeroepen tot kampioen standwerker van de bekende Haagse Markt.

In de wereld van de paardenraces was hij ook een bekend gezicht op Duindigt. Zelf was hij eigenaar van 58 paarden en een bijzonder verhaal om te vertellen gaat over een bezoek van Jan aan het graf van zijn vrouw Corrie op begraafplaats St. Barbara, in gezelschap van één van zijn paarden, Royal Justiena. Hij ging de zegen van zijn vrouw vragen voor een aanstaande race met de woorden: "Lieve Corrie, Royal Justiena moet morgen winnen." De volgende dag won Royal Justiena, met de zoon van Jan als Jockey, inderdaad de race op Duindigt.

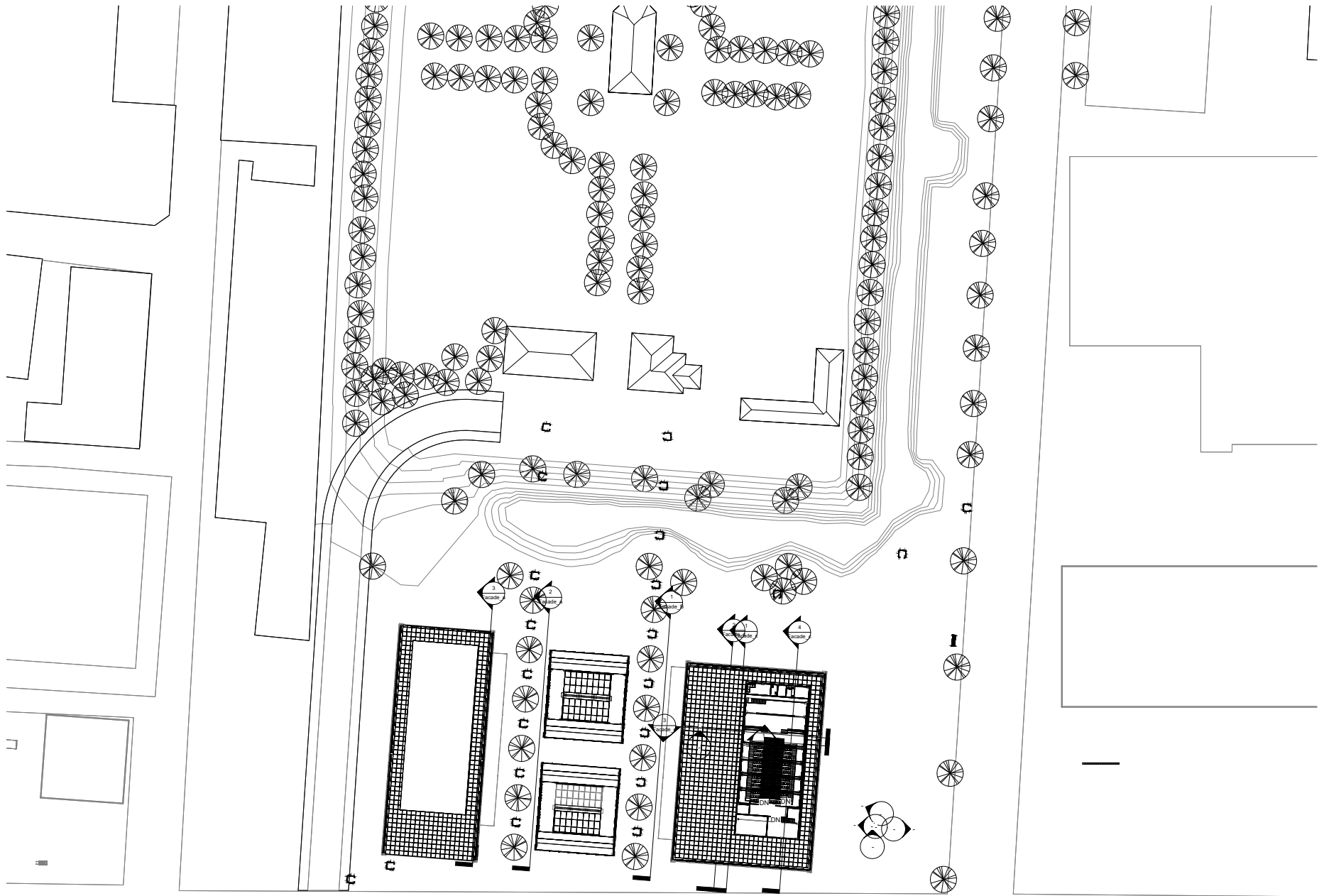

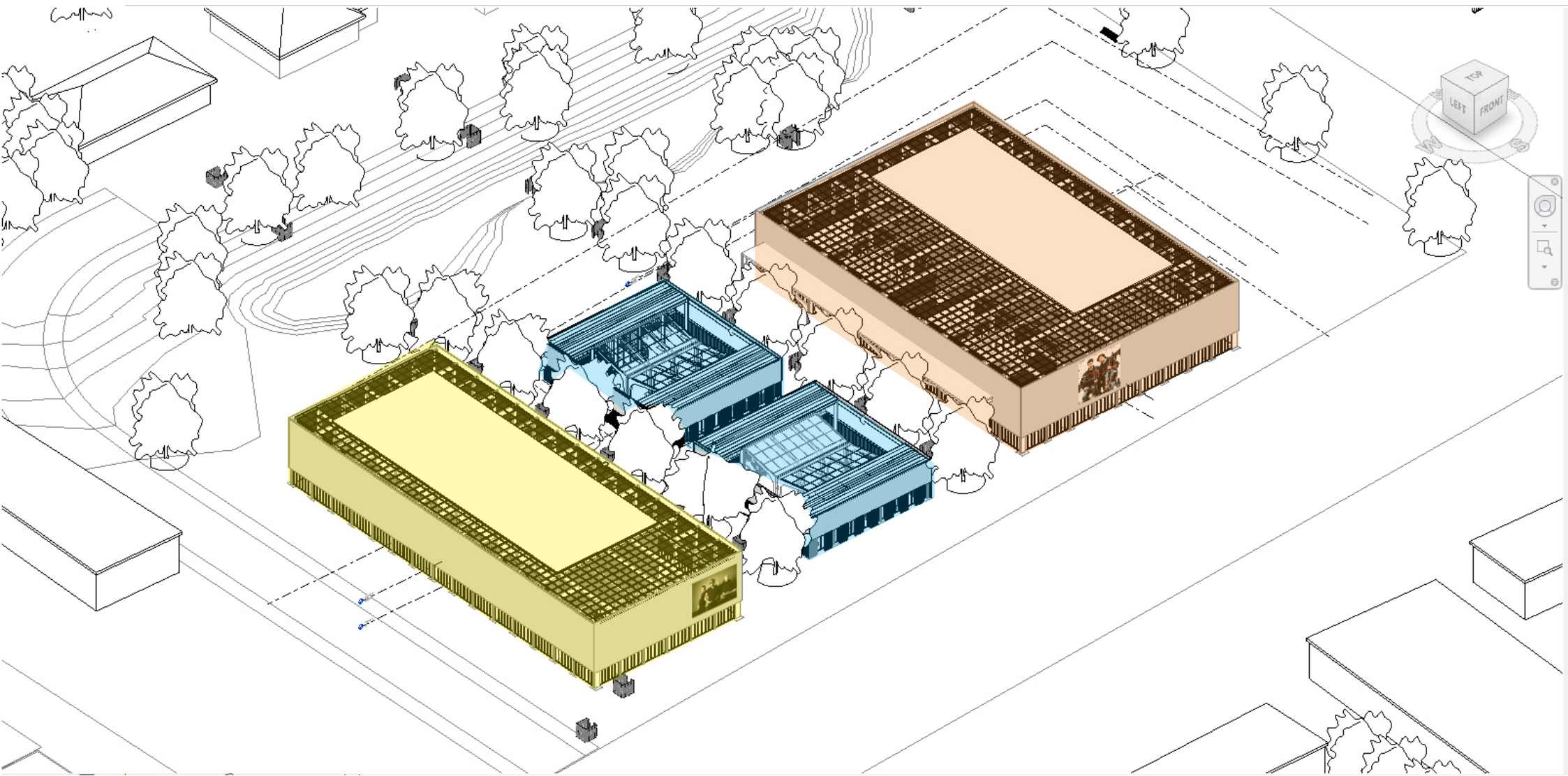

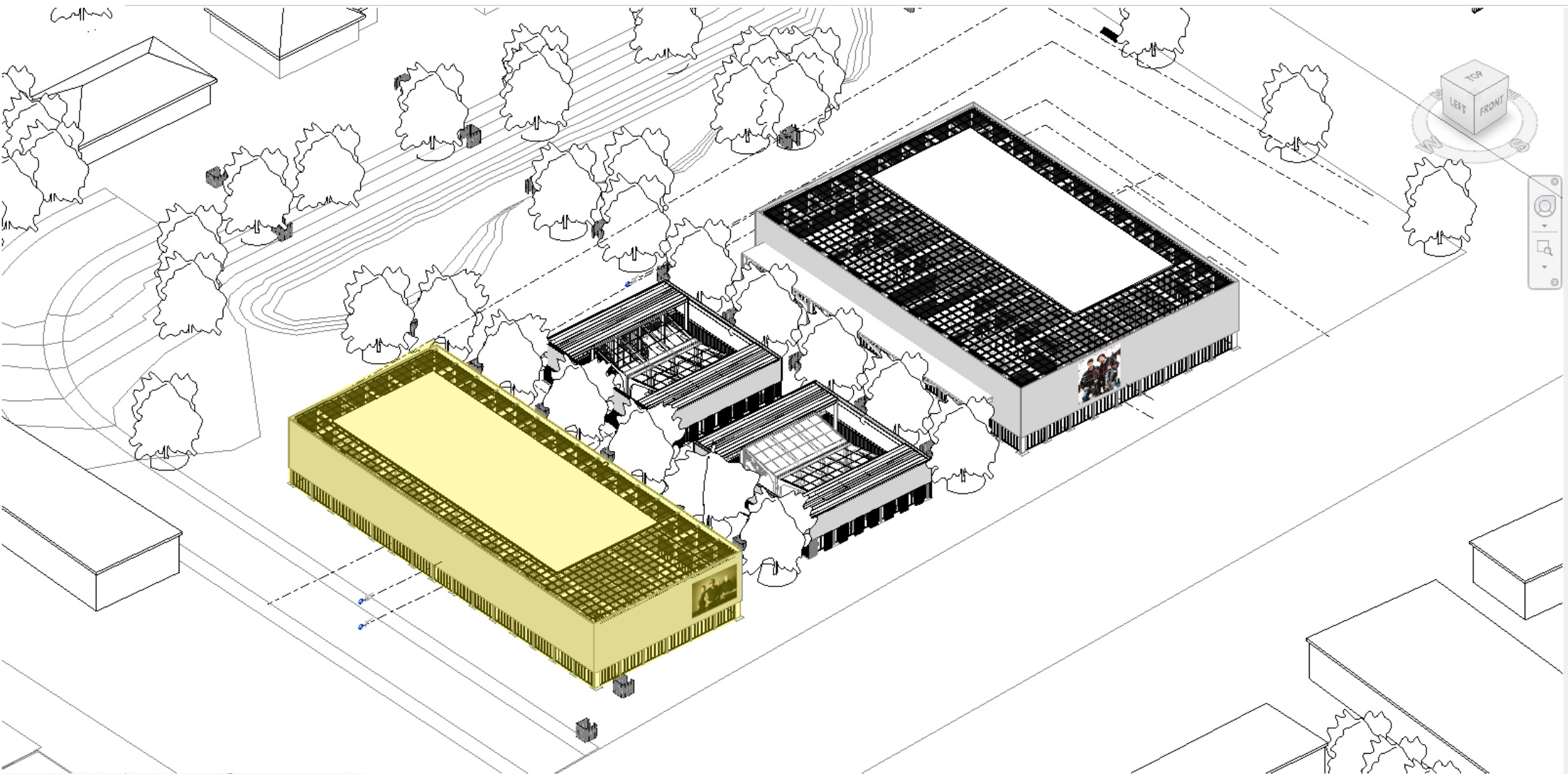

Pop Venue

Venue Space / Restaurant	320m <sup>2</sup>
Back Stage Area	128m <sup>2</sup>
Toilet Space	62m <sup>2</sup>
Wardrobe/Lobby	24m <sup>2</sup>

ER-Room	8m <sup>2</sup>
Office	15m <sup>2</sup>
Guest Stay	24m <sup>2</sup>
Storage	20m <sup>2</sup>

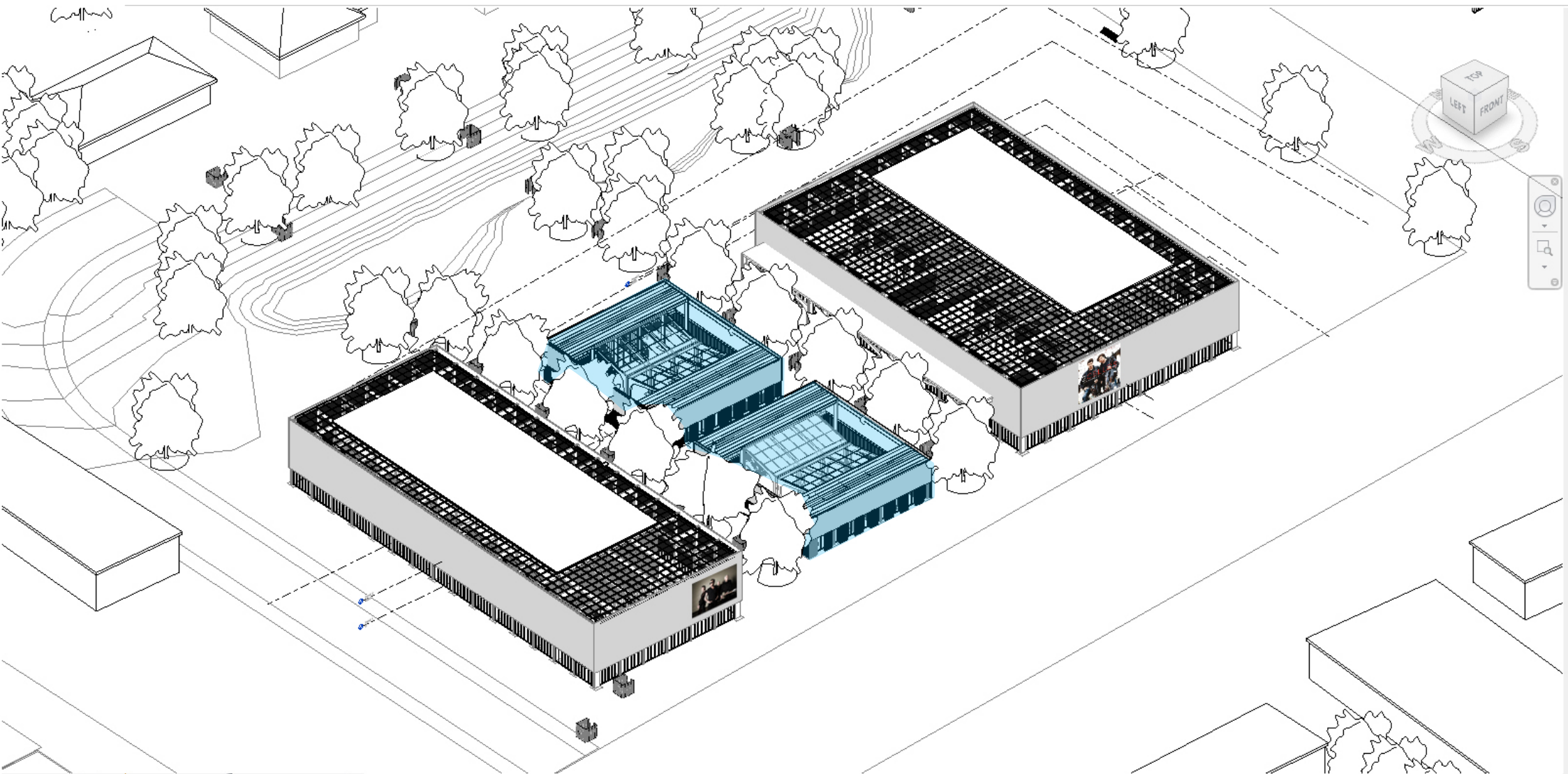

Educational Pavilions

Library	340m2
Office Space	80m2
Condoleanse/Historic	420m2

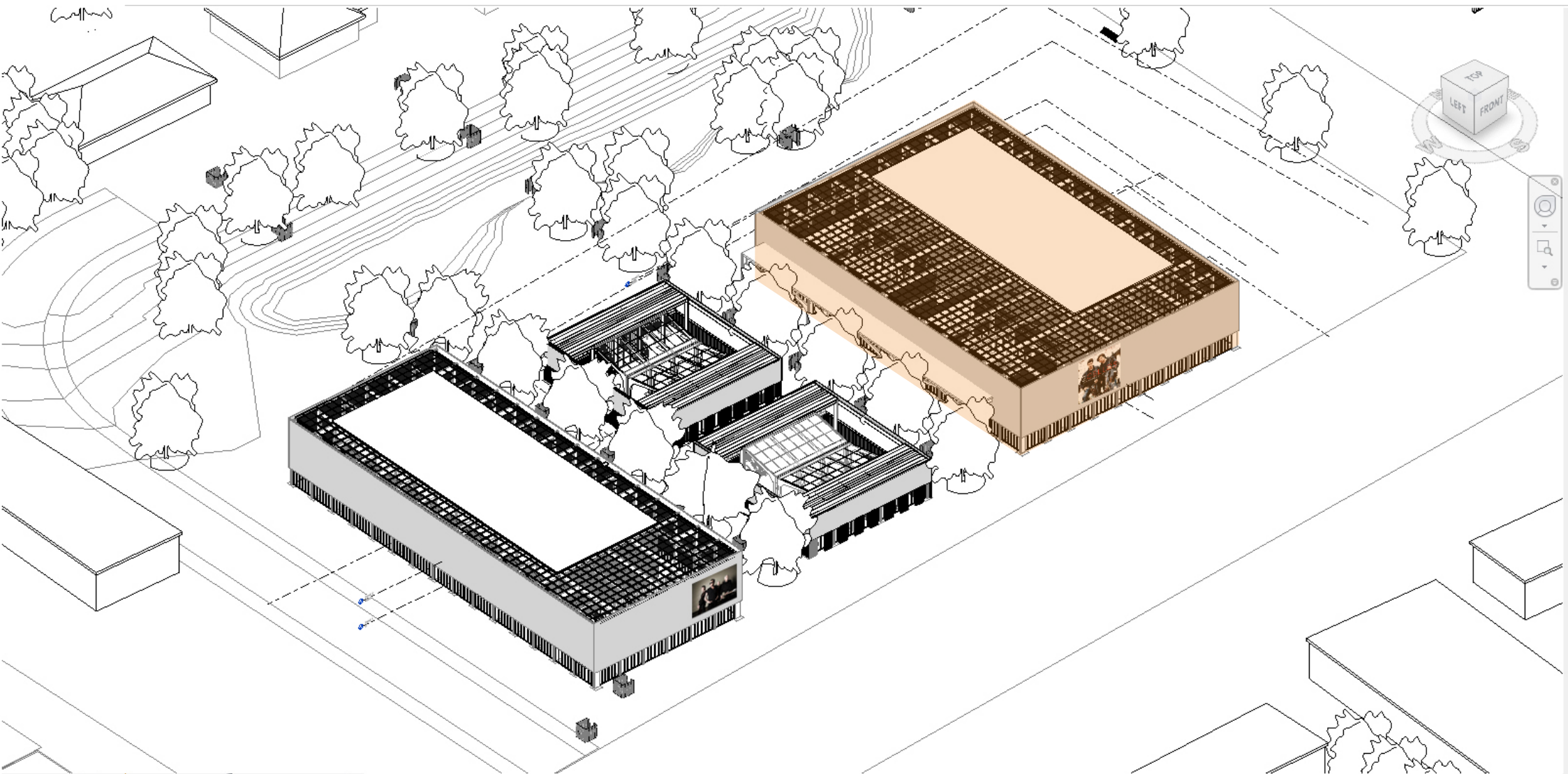

Classical Venue

Venue Space /	320m2	ER-Room	8m2
304 Seats		Office	15m2
Back Stage Area	100m2	Guest Stay	48m2
Toilet Space	55m2	Storage	52m2
Wardrobe/Lobby	32m2	Studio Space	122m2



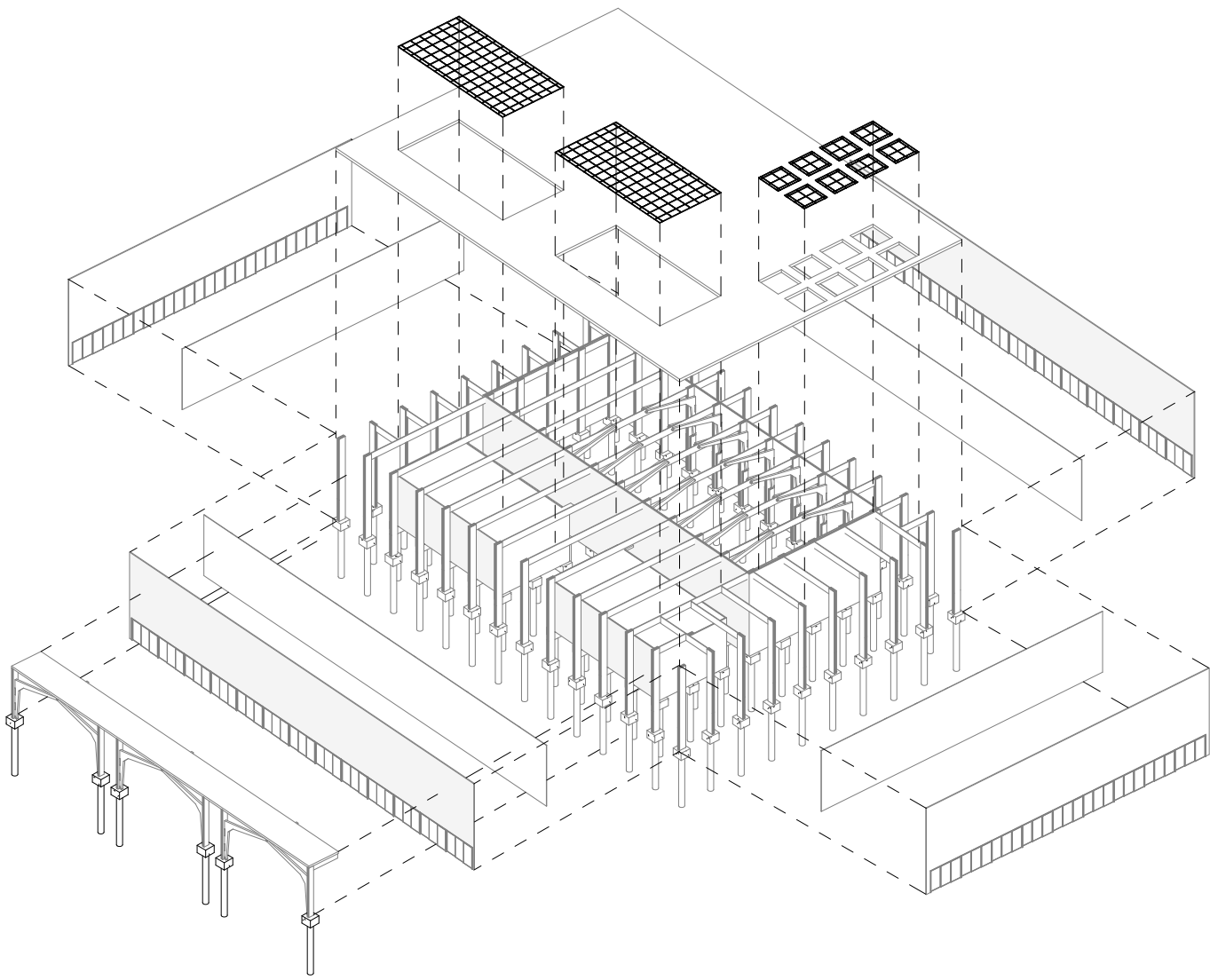

Exploded view Structure

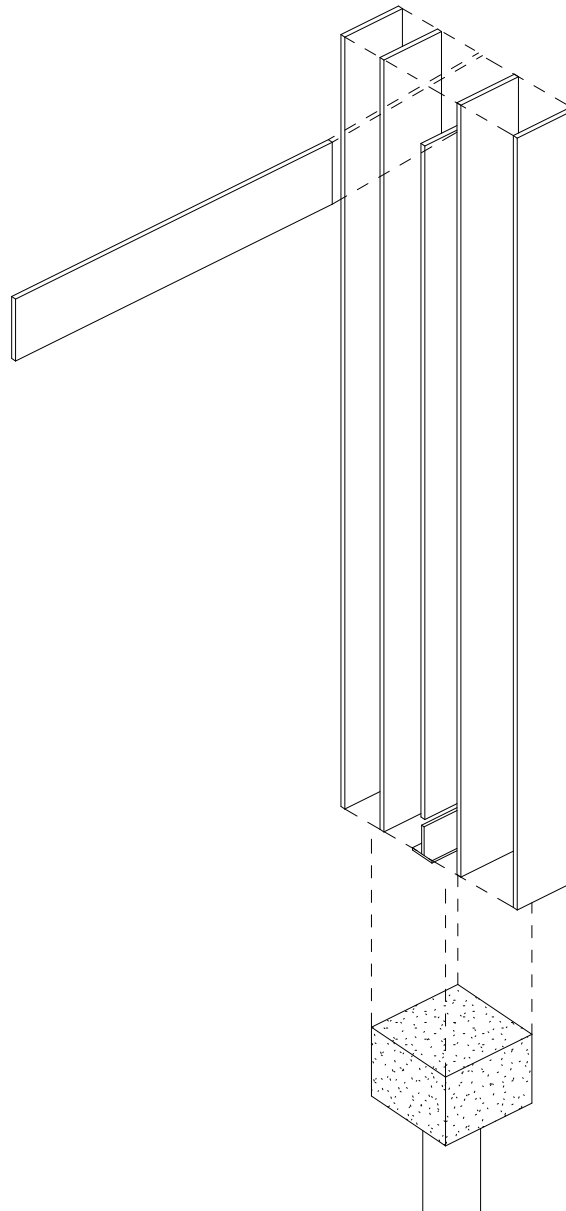

Column construction

# Structure Building procedure 1

## Foundation and columns

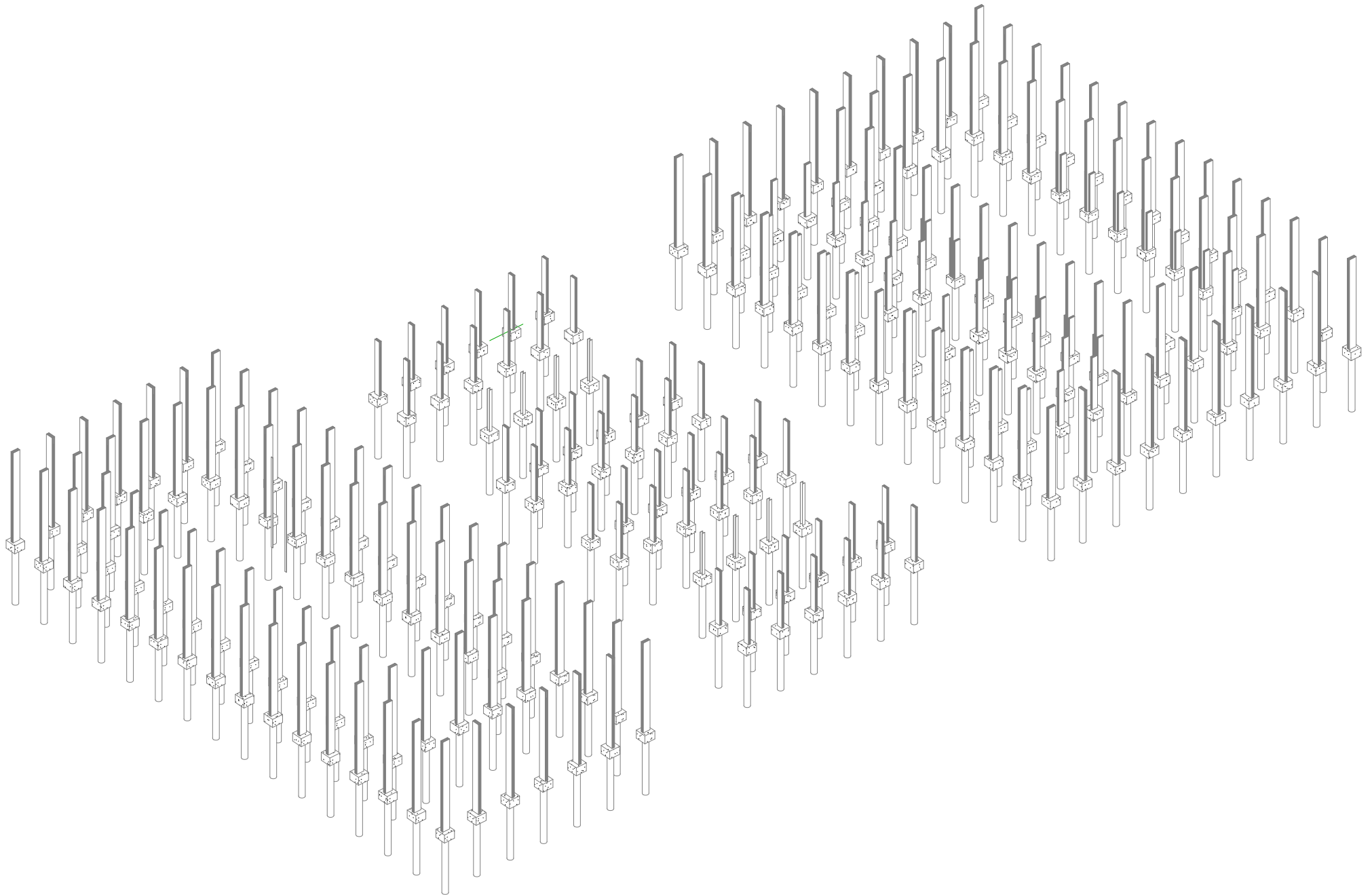

# Structure Building procedure 1

## Kerto Ivl Beam

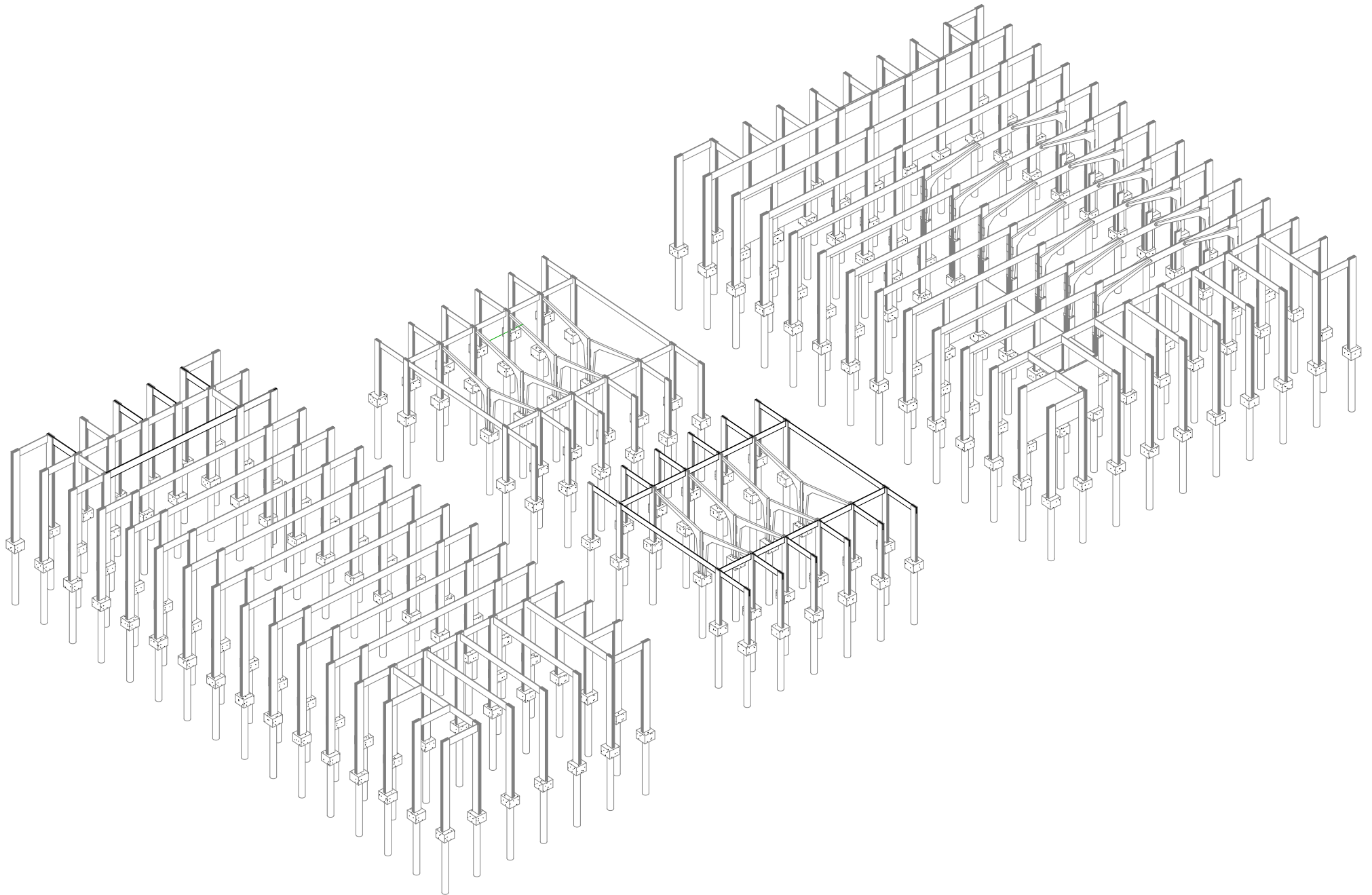

# Kerto Q-Panel 50mm

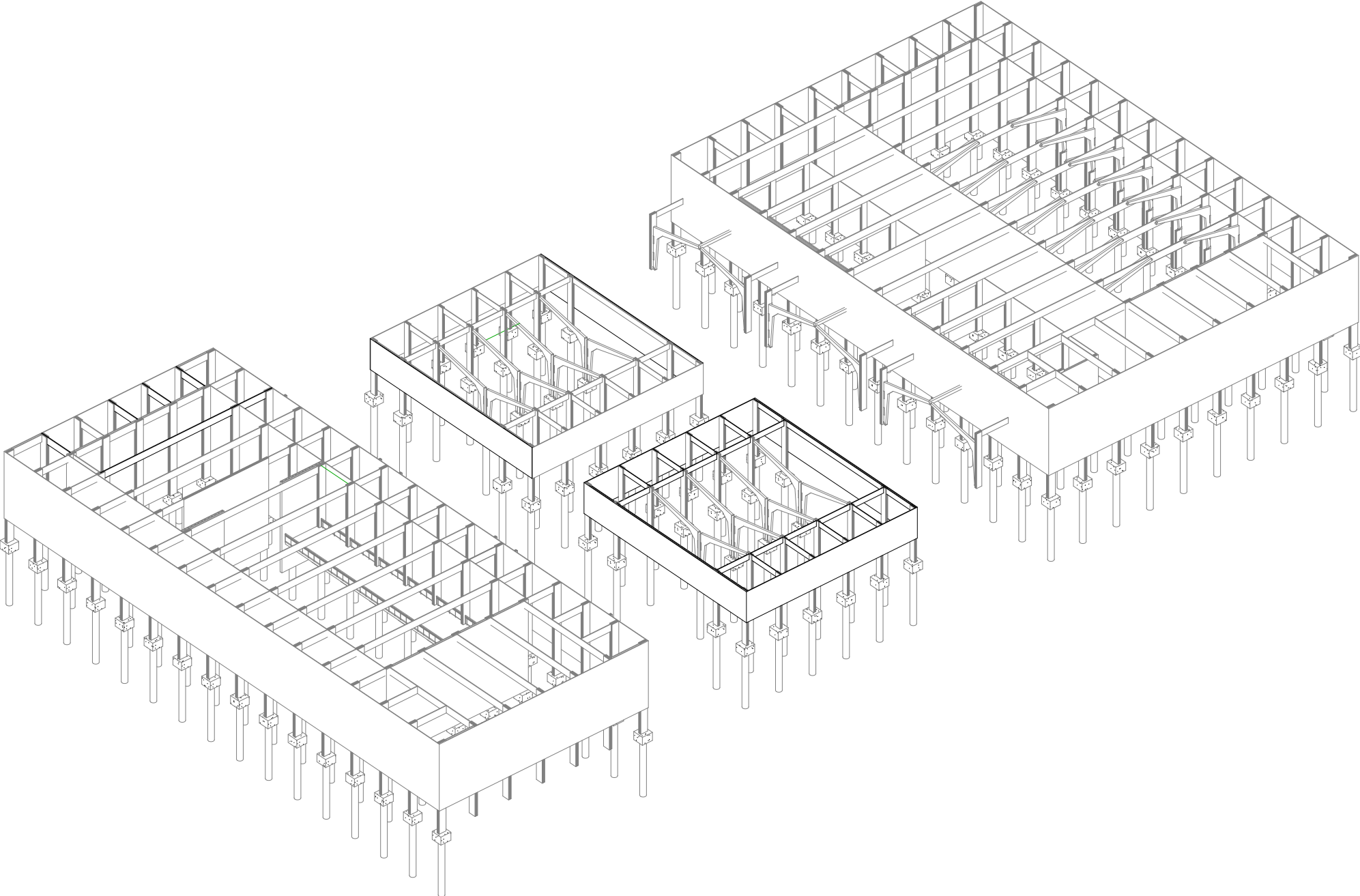

# ClickBrick

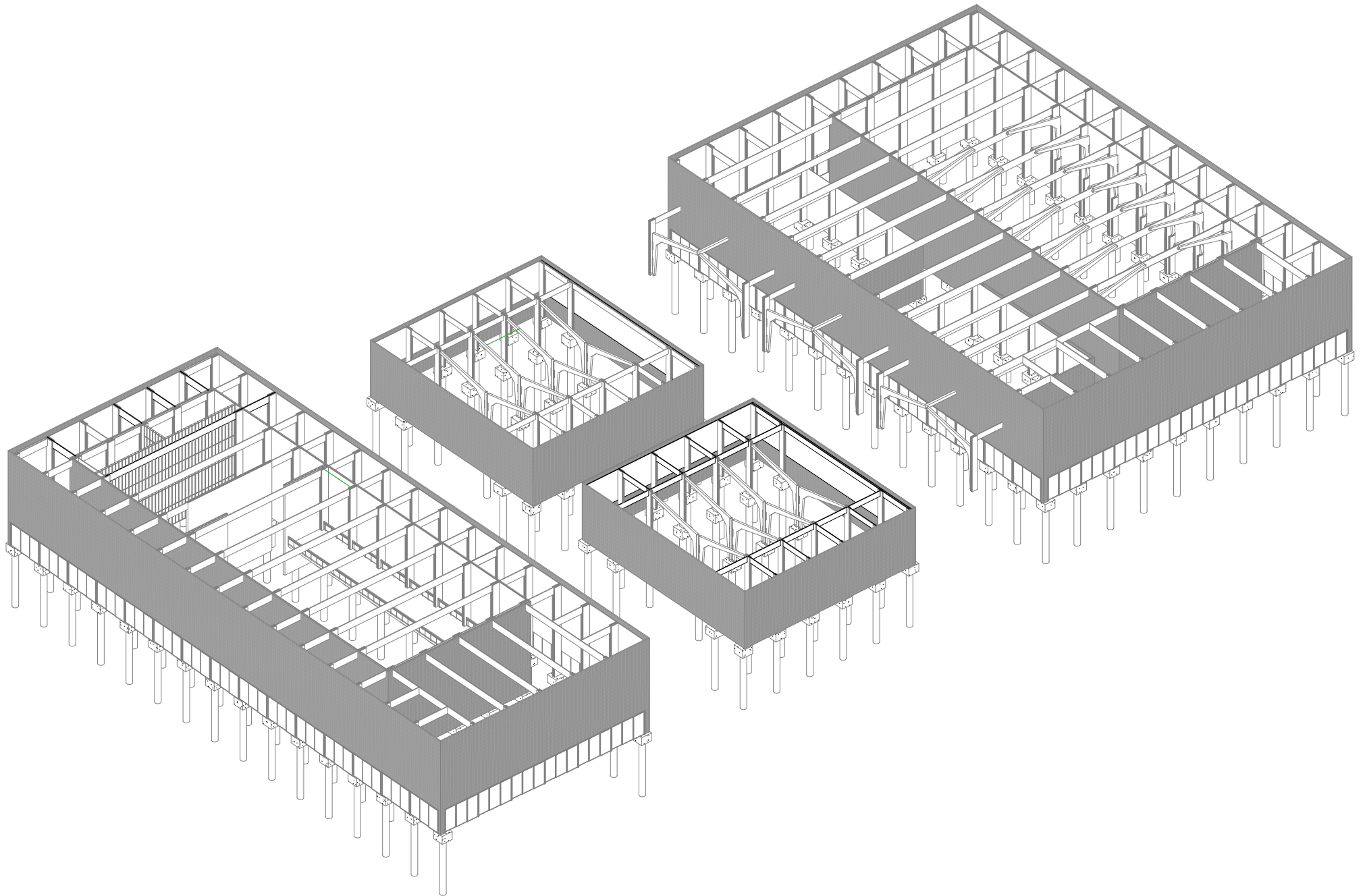

## Structure Building procedure 3 Roof and skylights

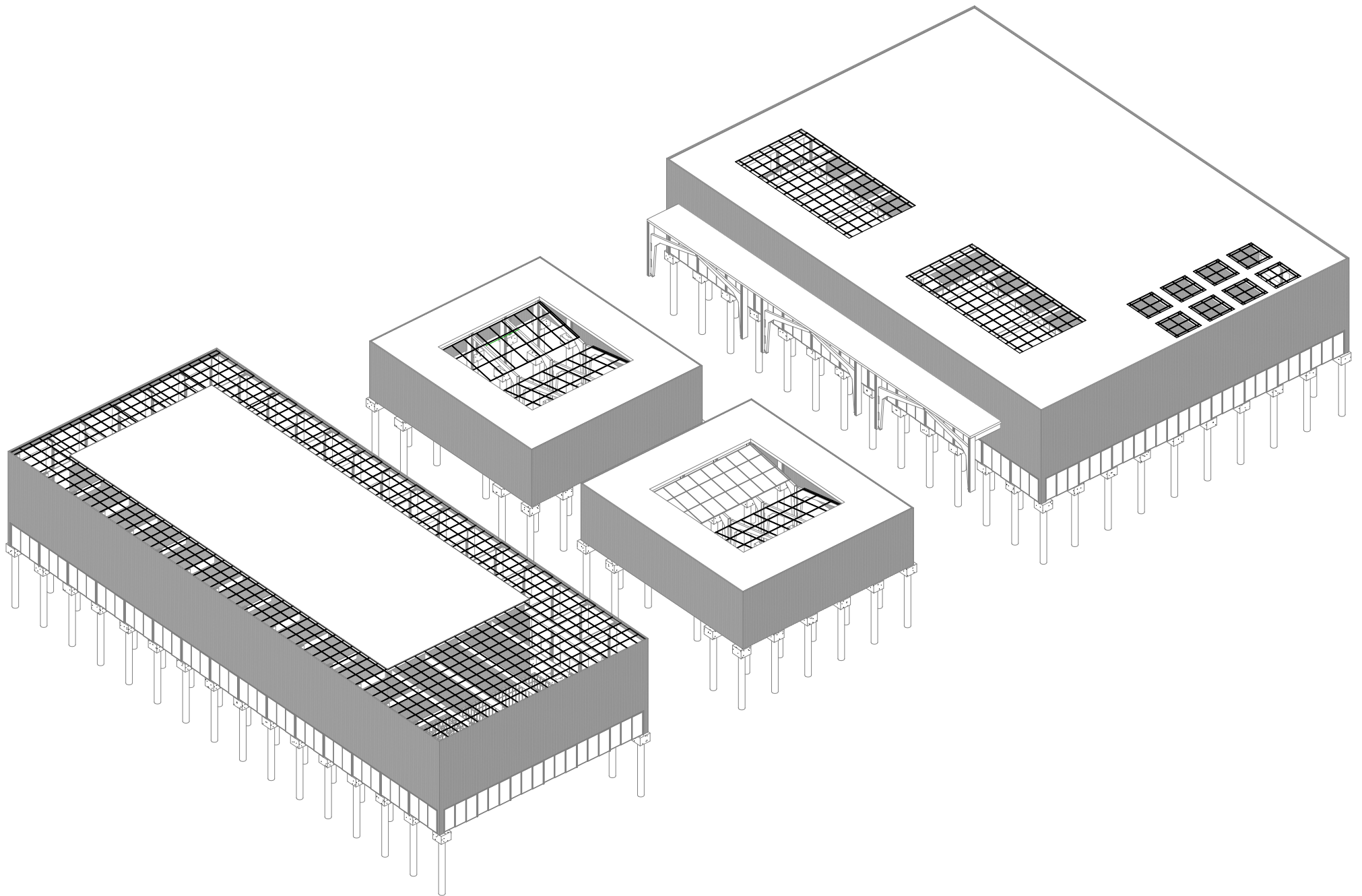

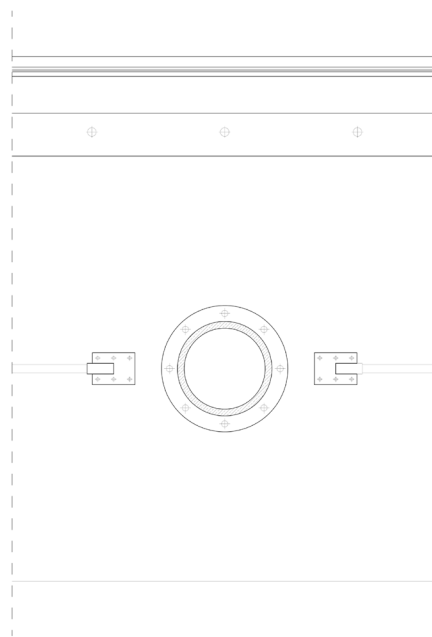
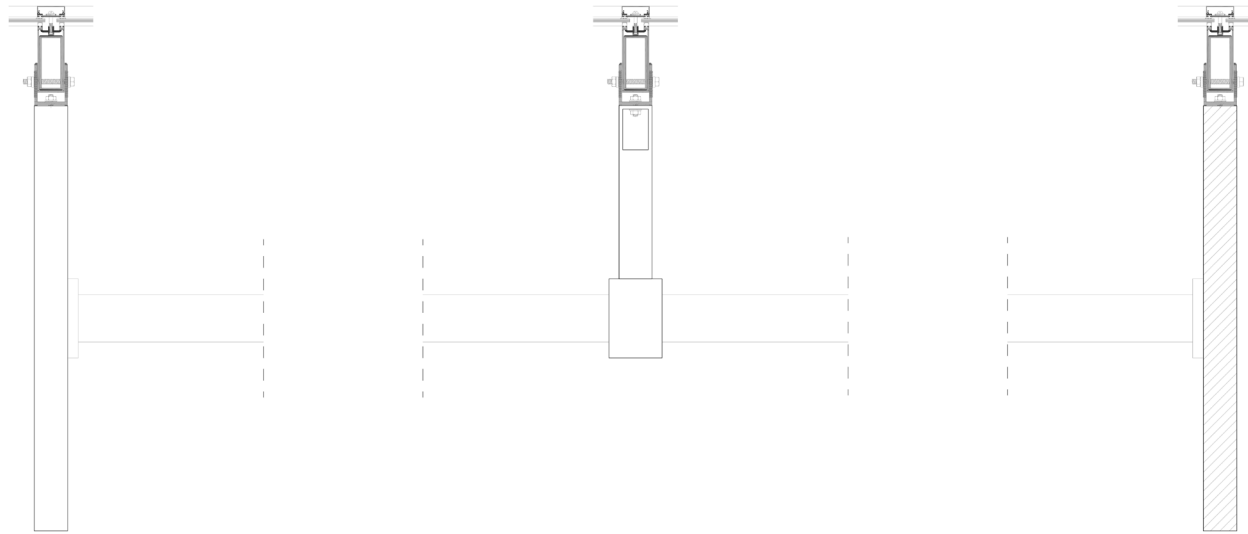

Roof Construction Details 1:5



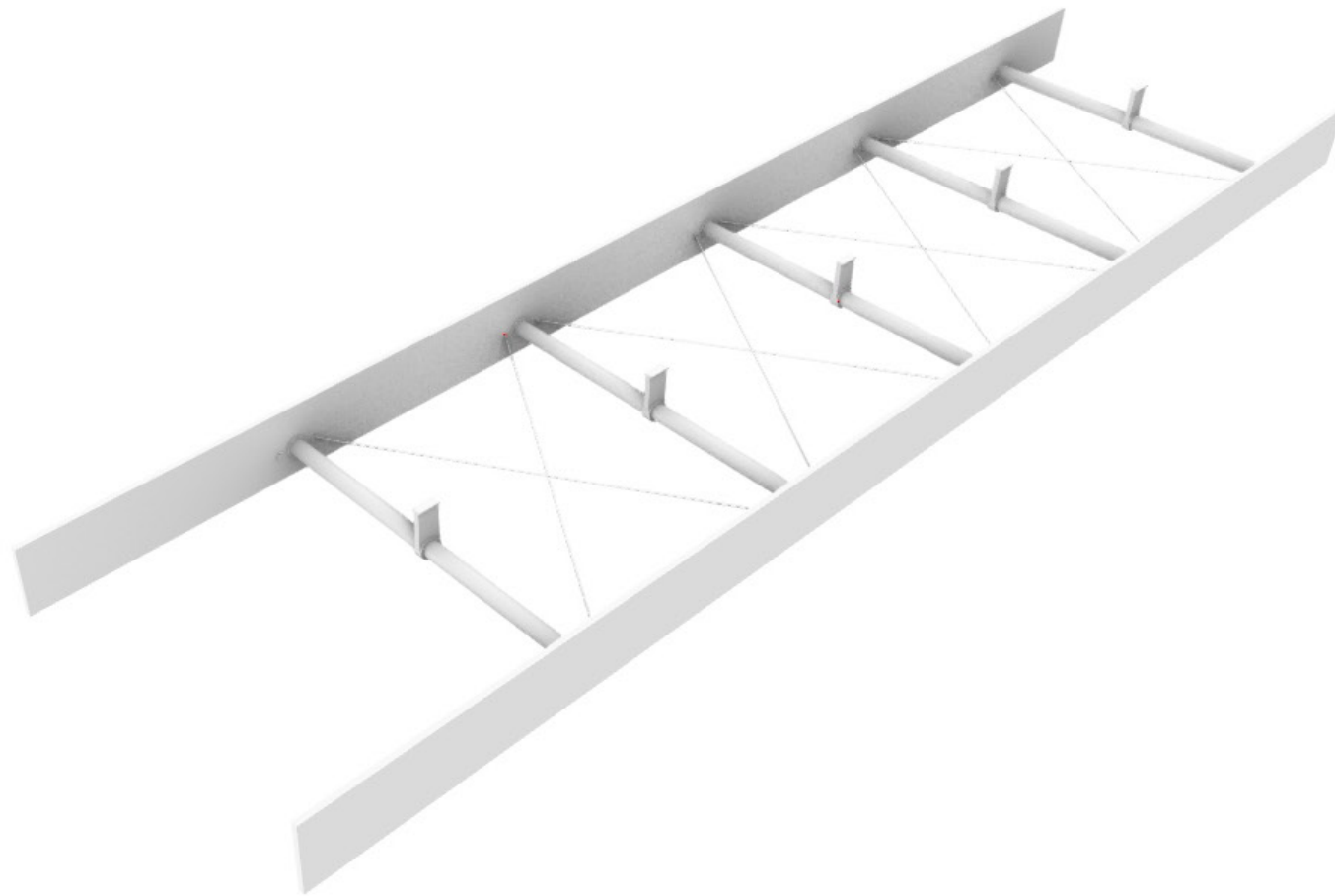

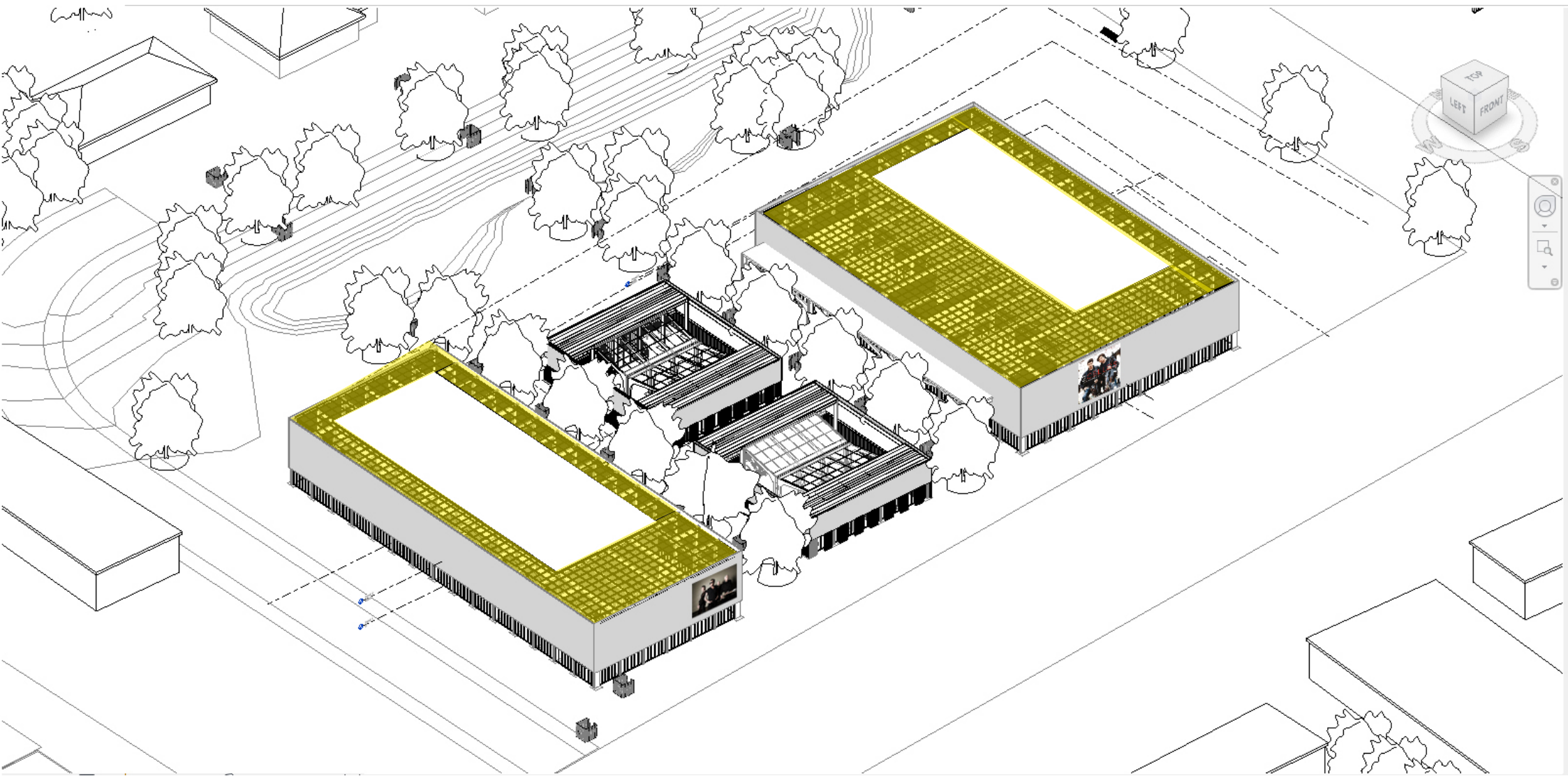

1968m2 Smart Glass by Physee

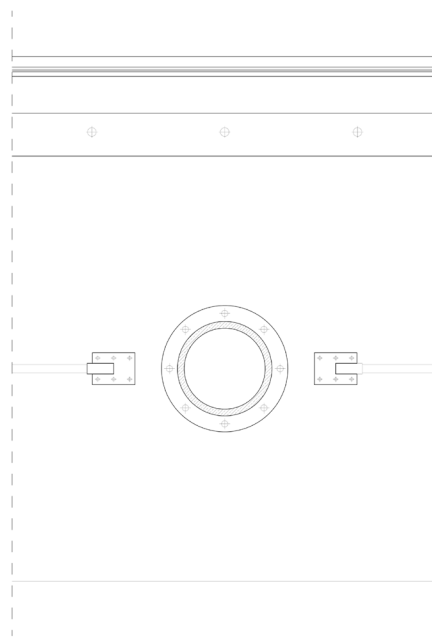
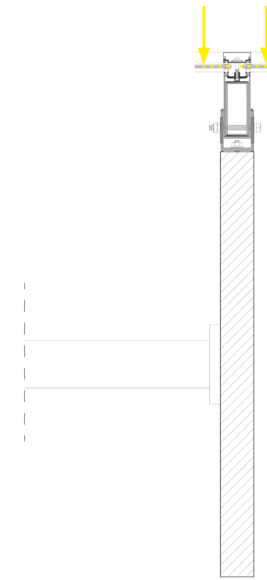
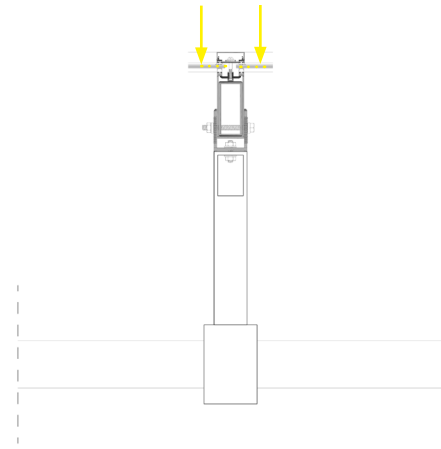
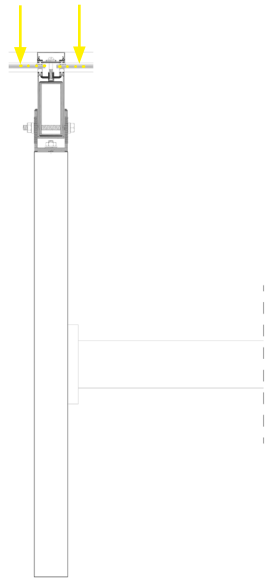

Roof Construction Details 1:5

Ground Floor

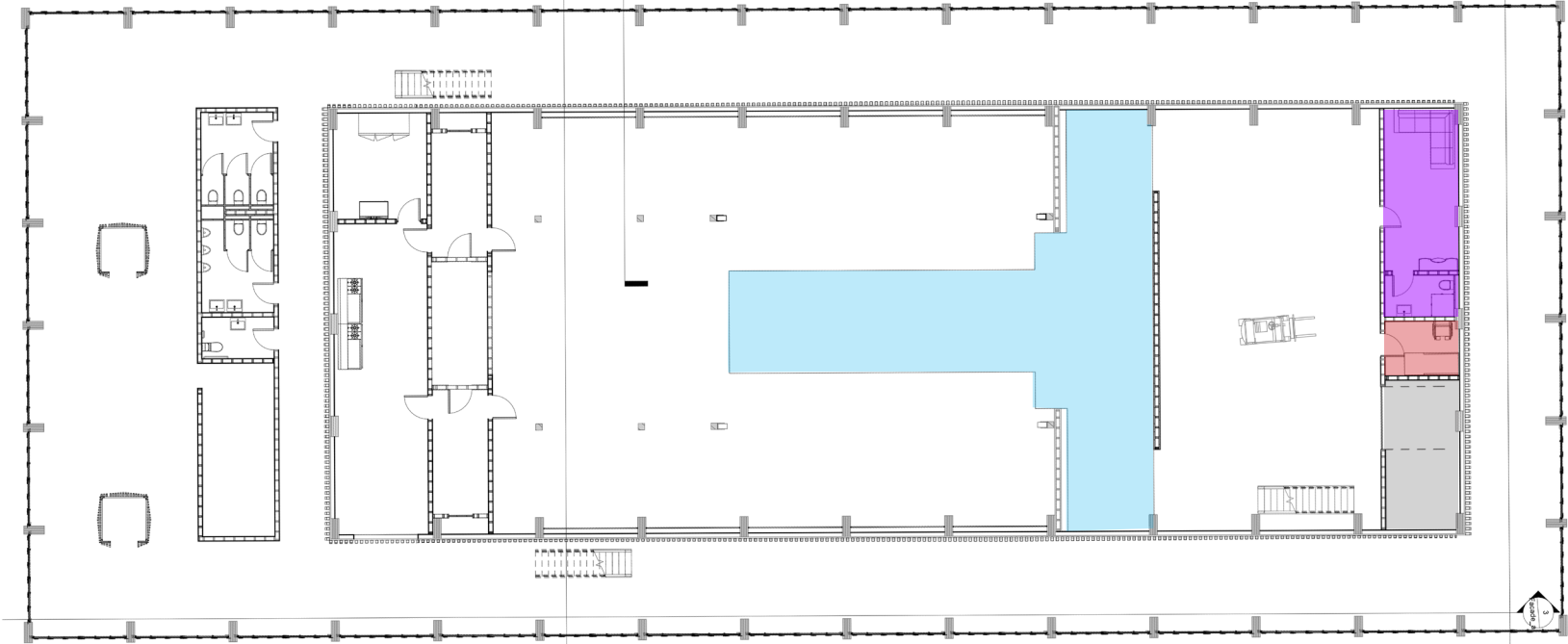

Second Floor

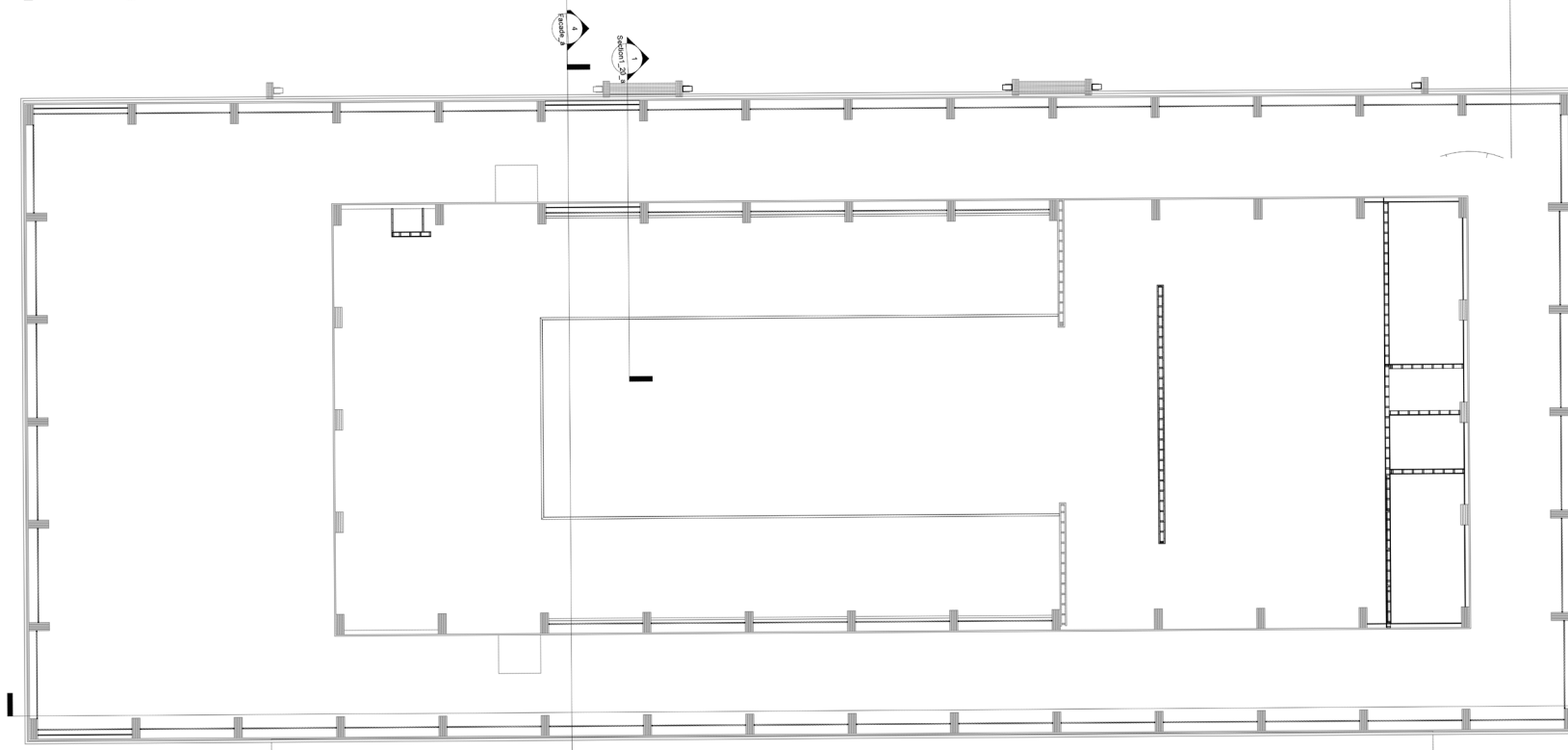

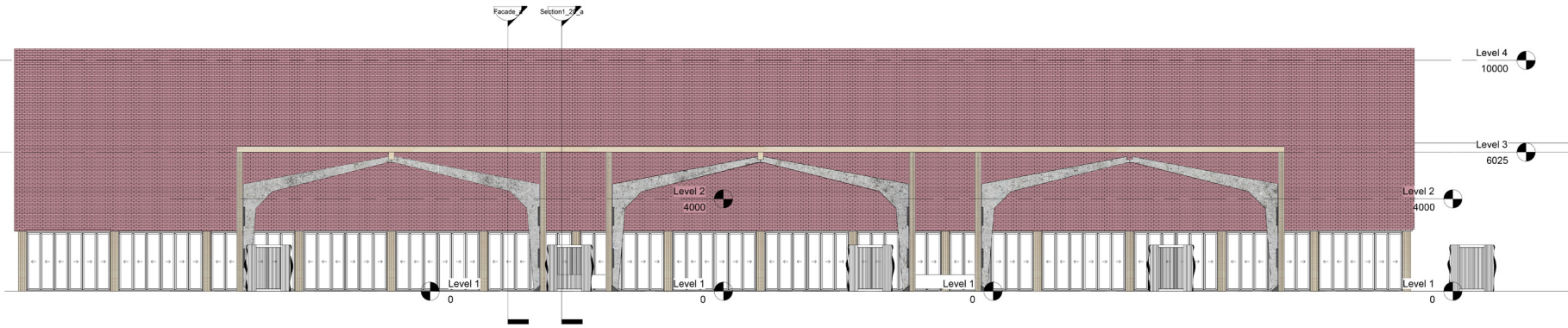

2 Exterior Facade Building 1  
1 : 100

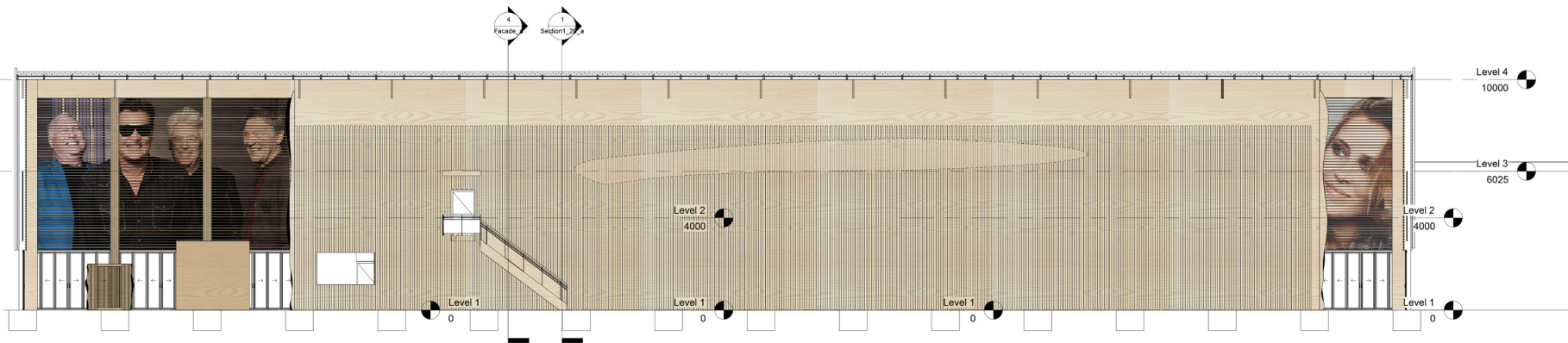

3 Interior Facade 1 Building 1  
1 : 100



1 Section 3  
1 : 100

Exterior and Interior Facade

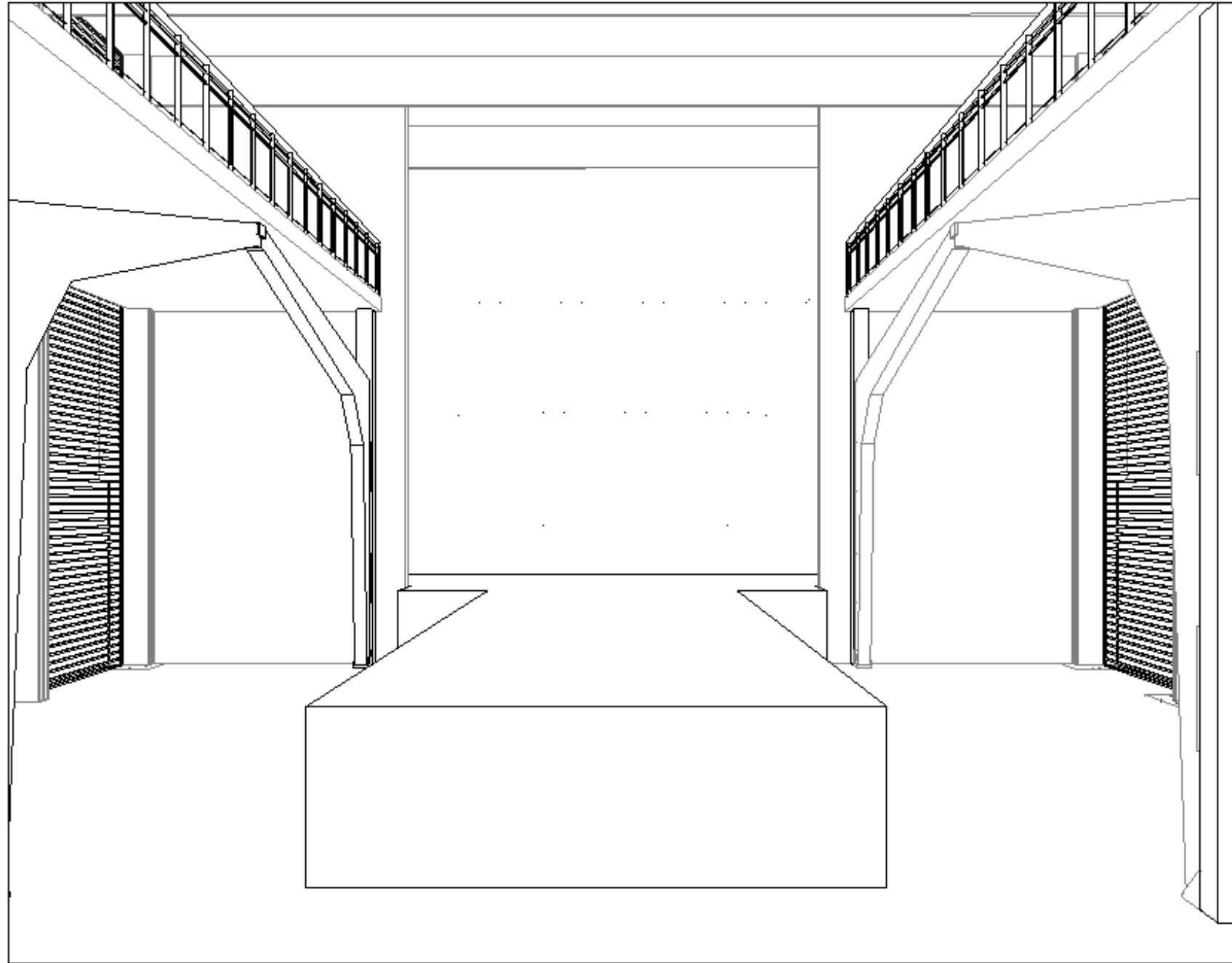

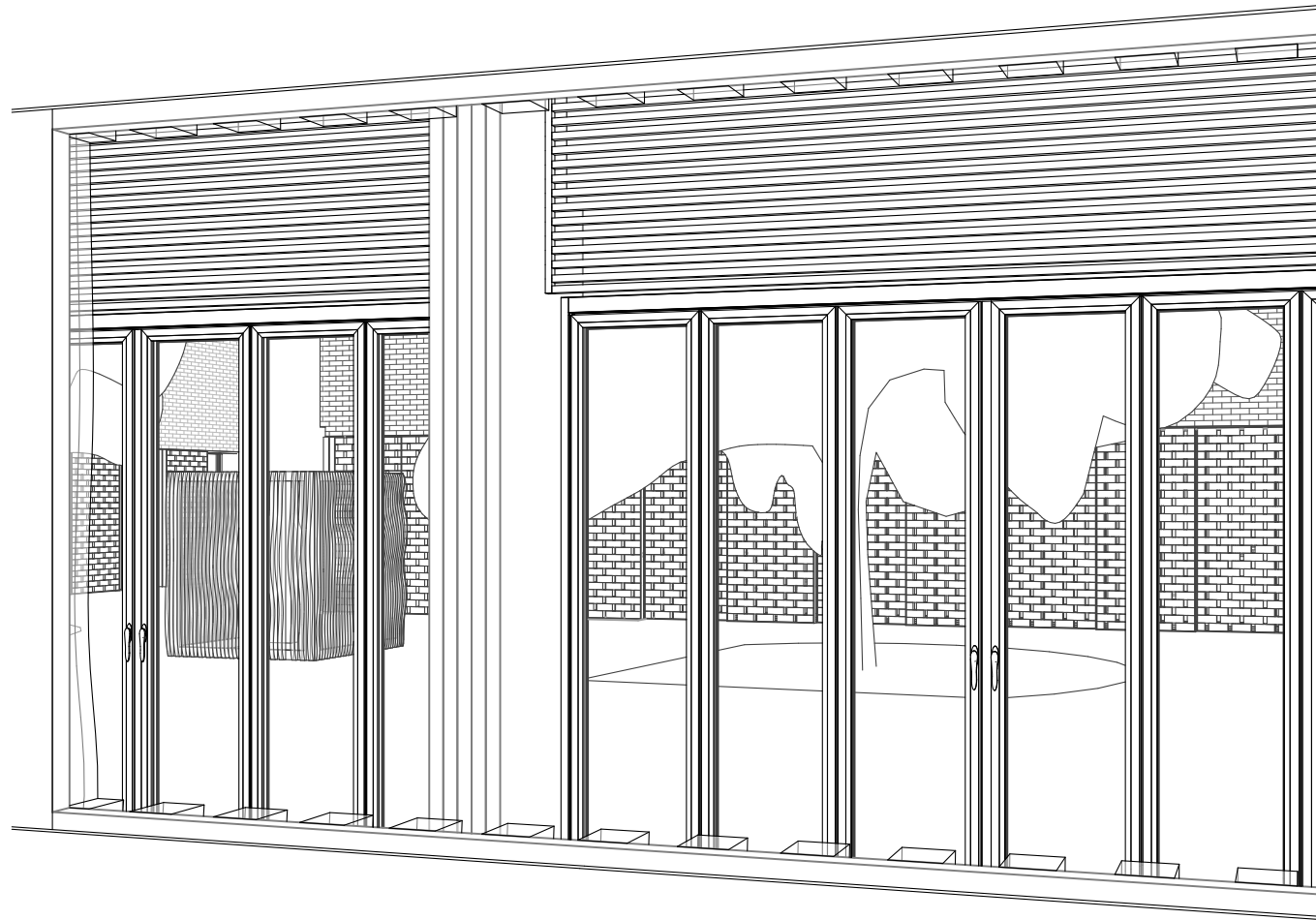

Connecting to the park

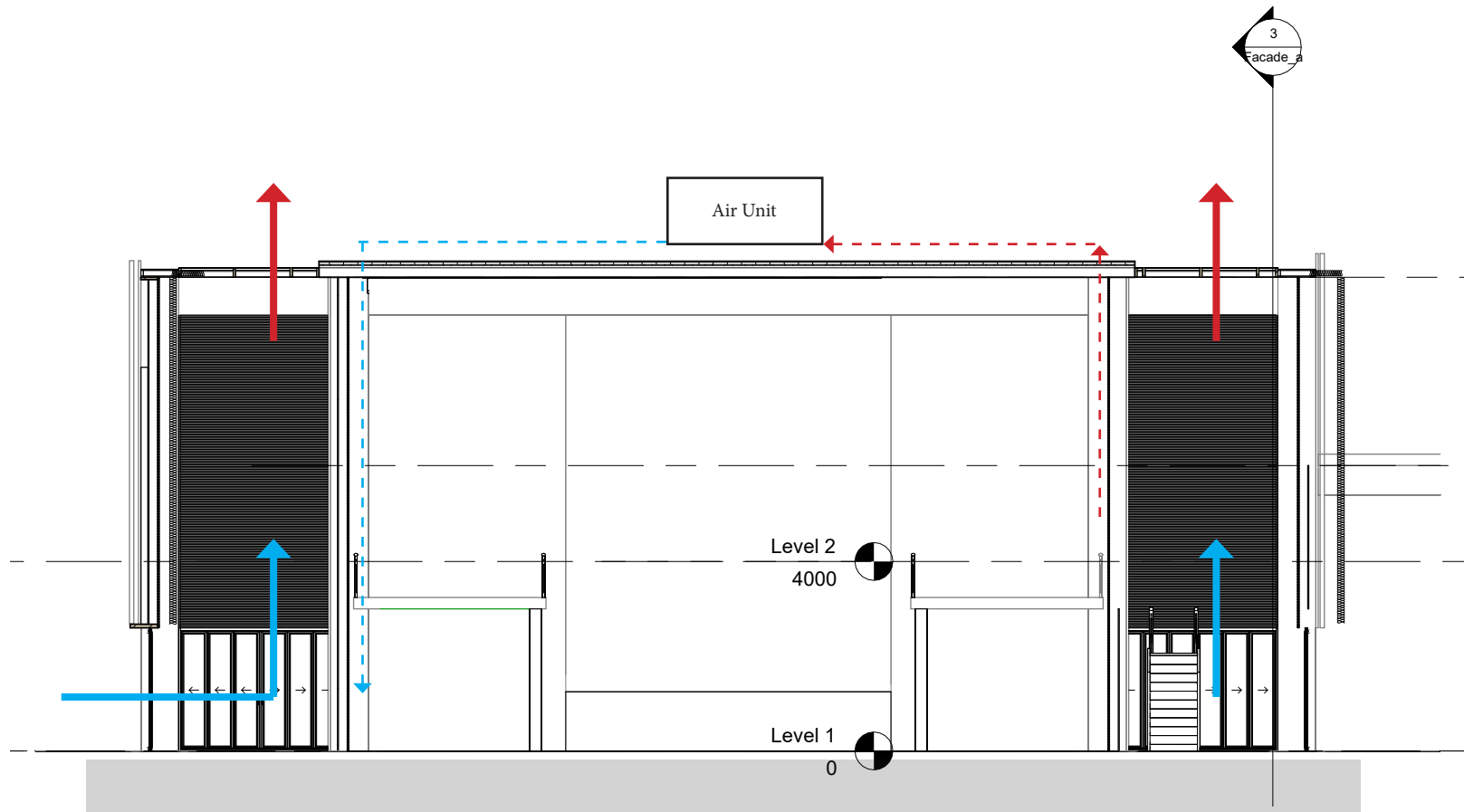



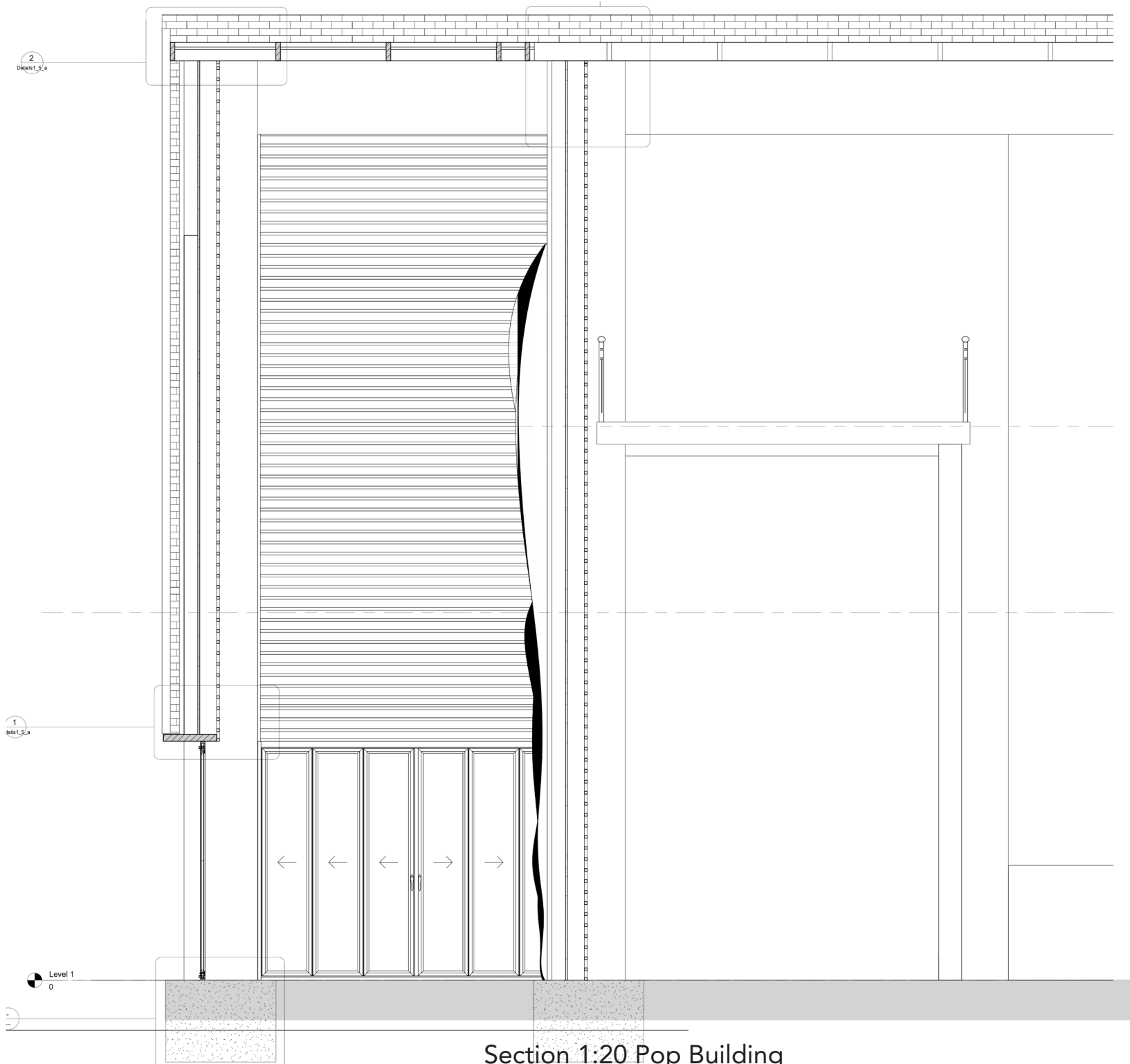

Section 1:20 Pop Building

# Details building 1

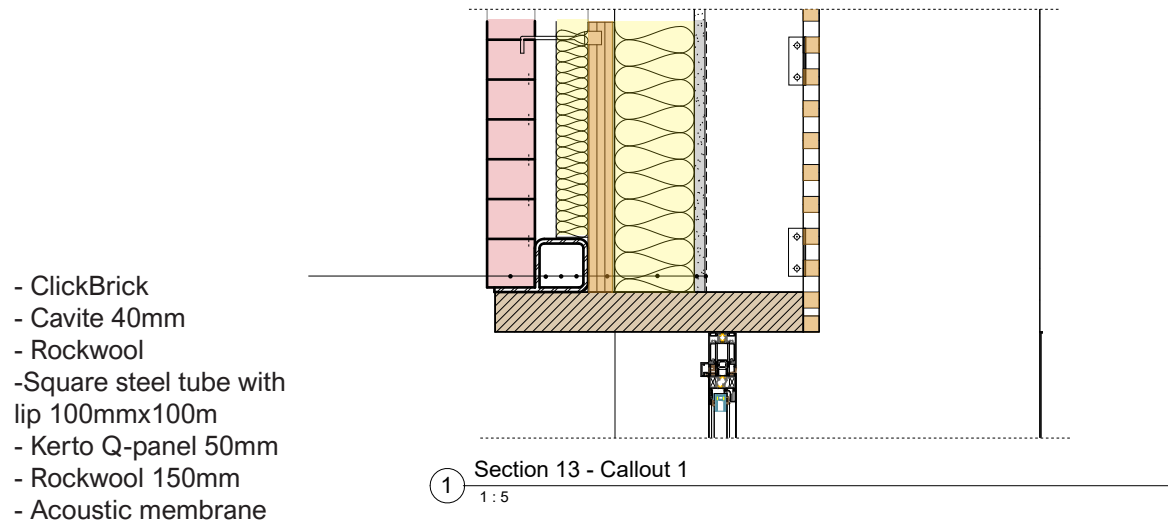
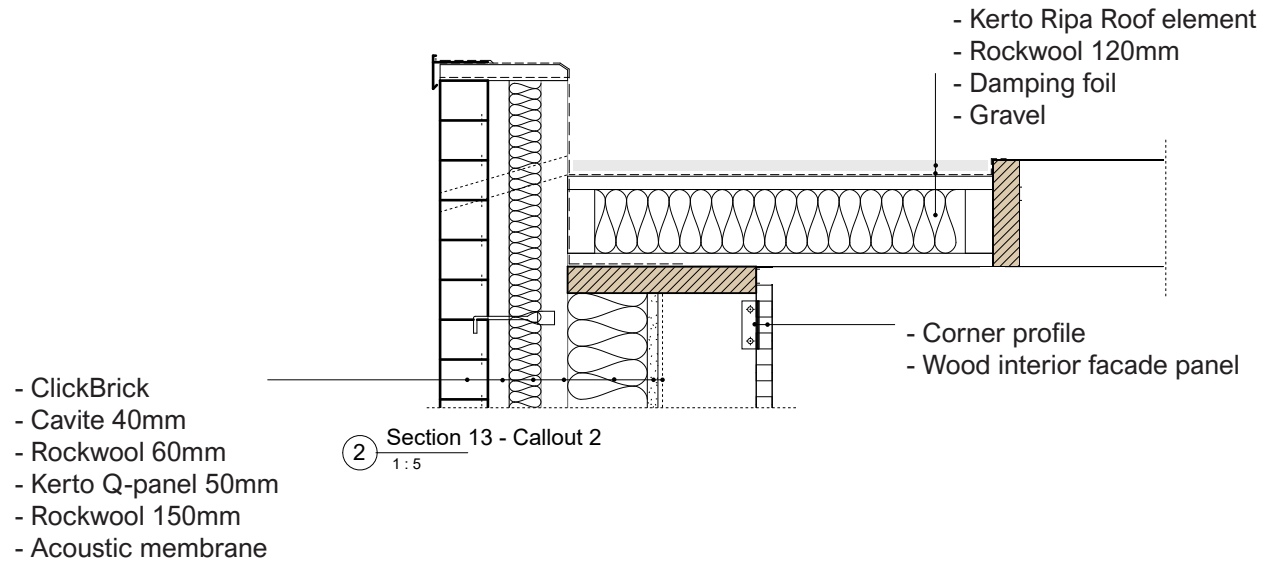

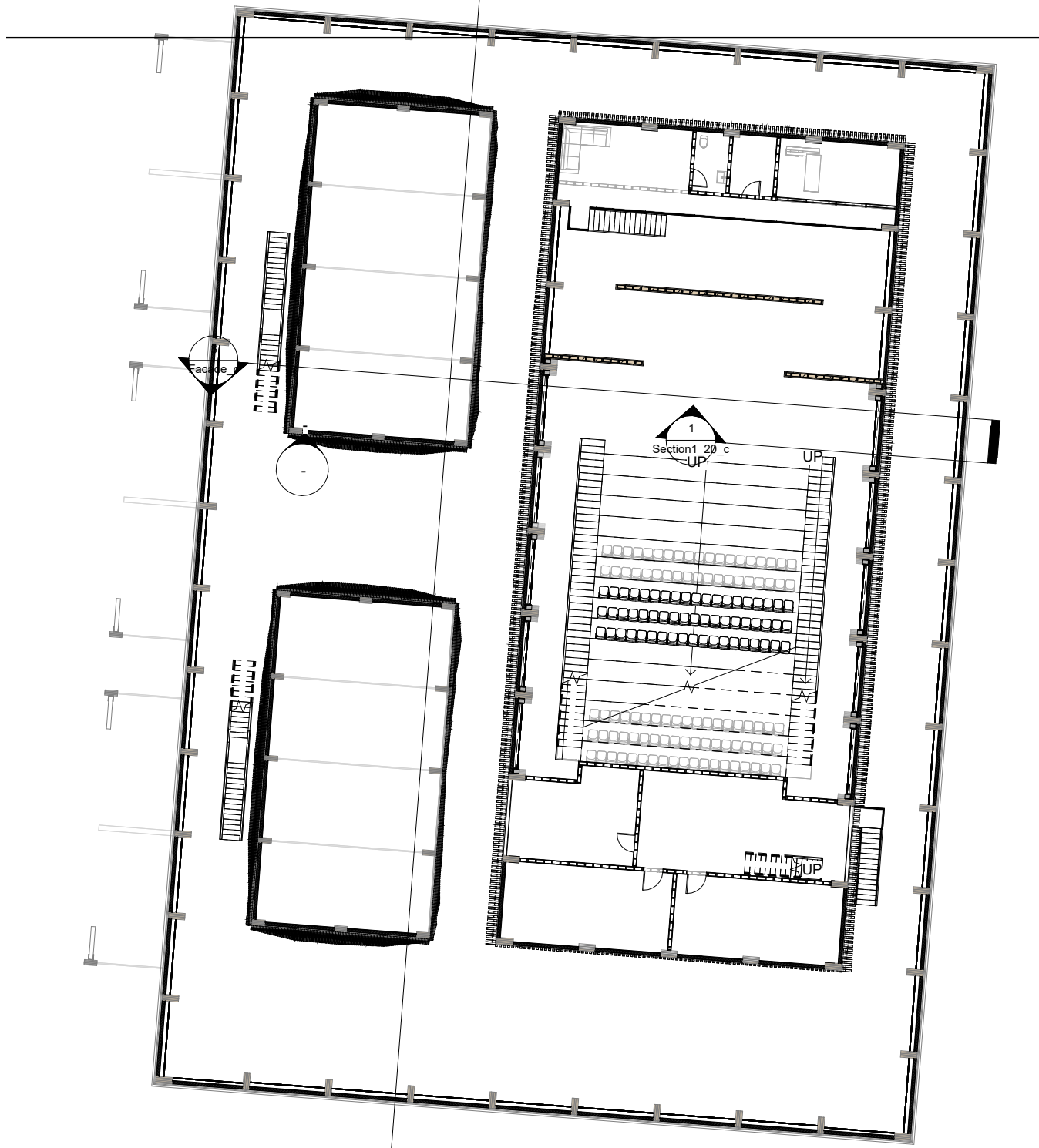

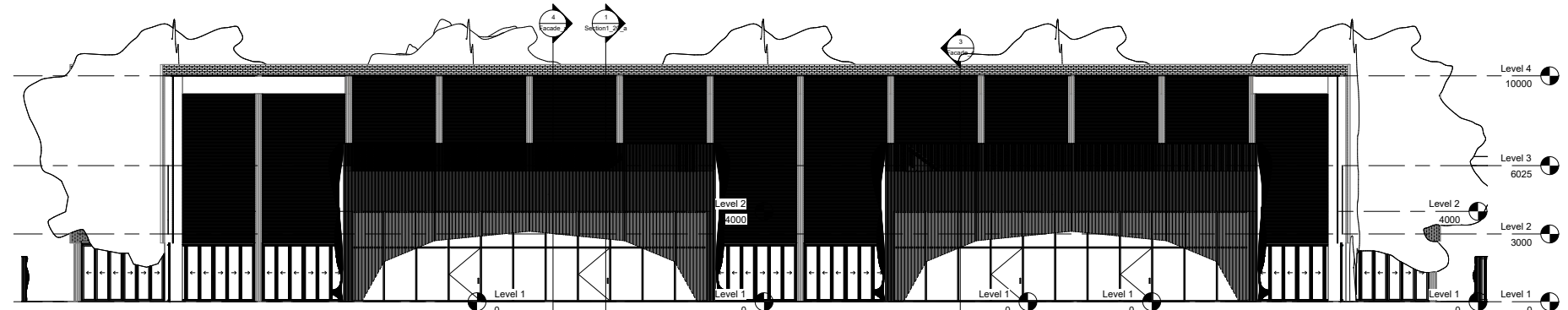

1 Interior Facade 1 Building 2  
1 : 100

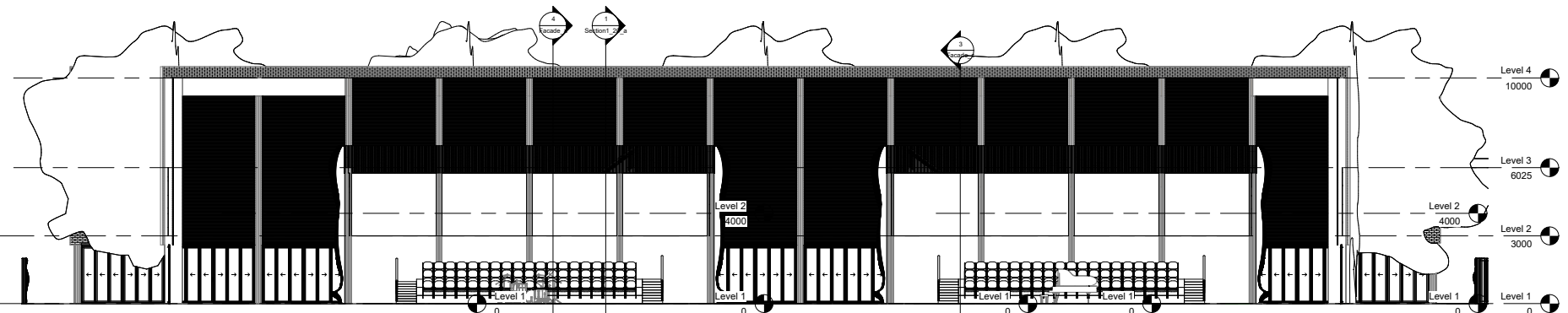

2 Interior Facade 2 Building 2  
1 : 100

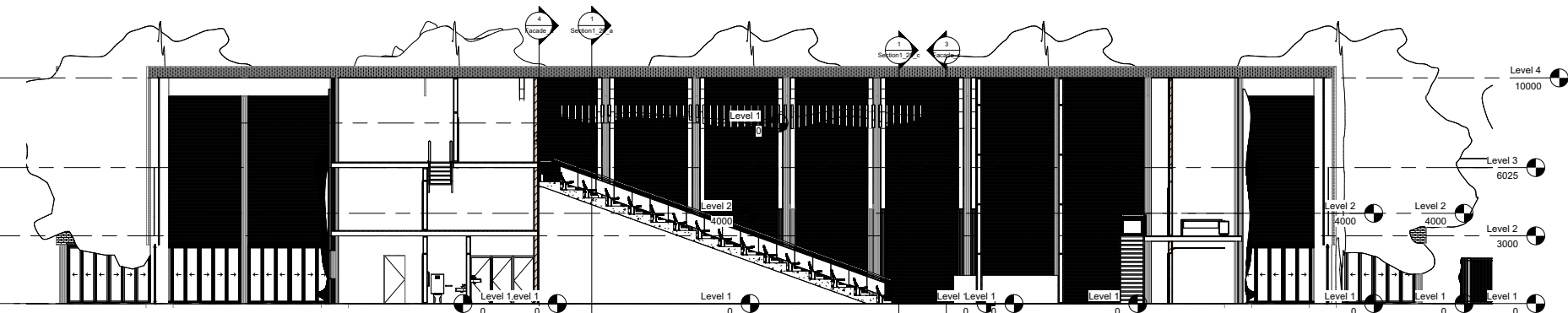

4 Interior Facade 4 Building 2  
1 : 100

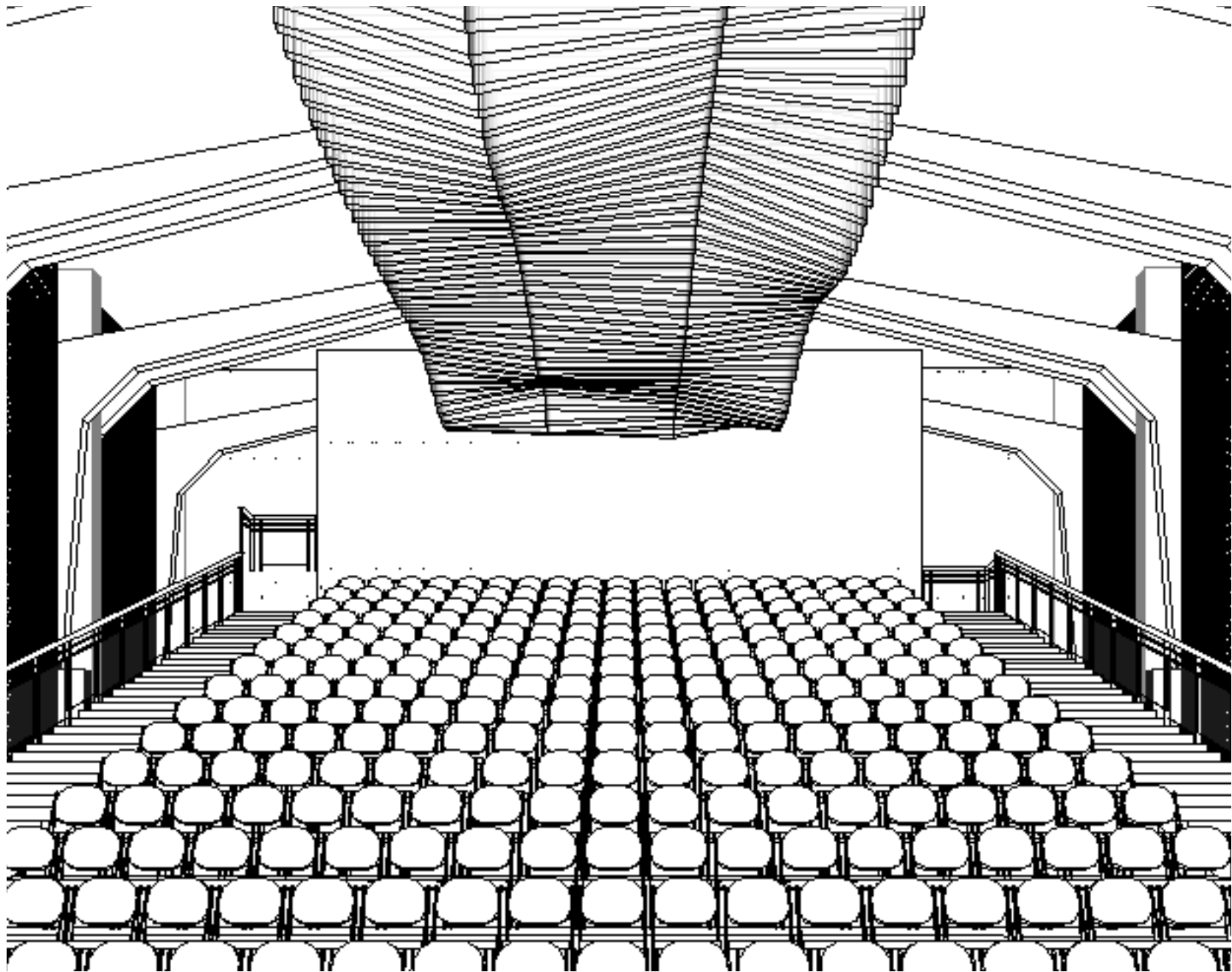

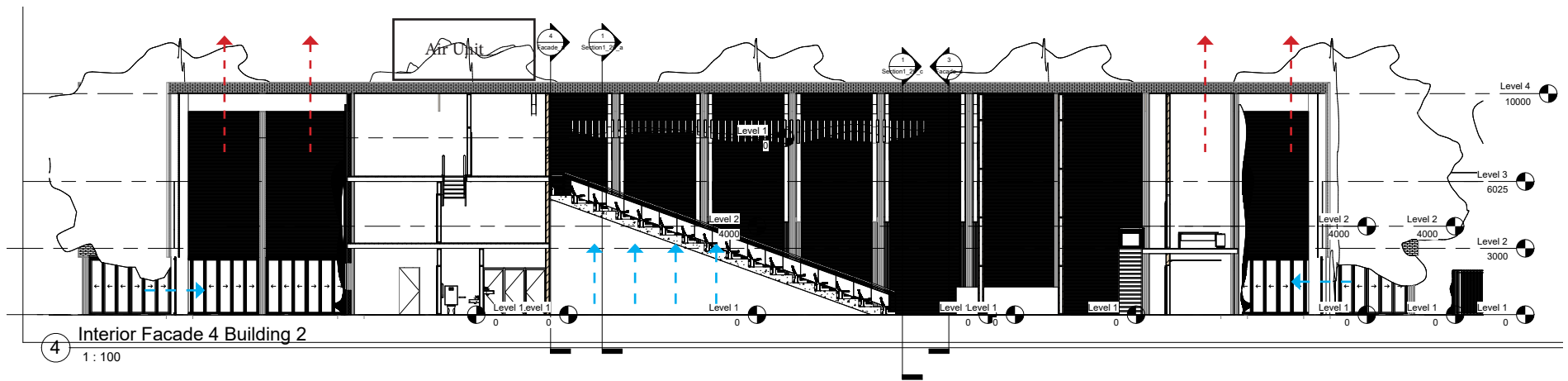

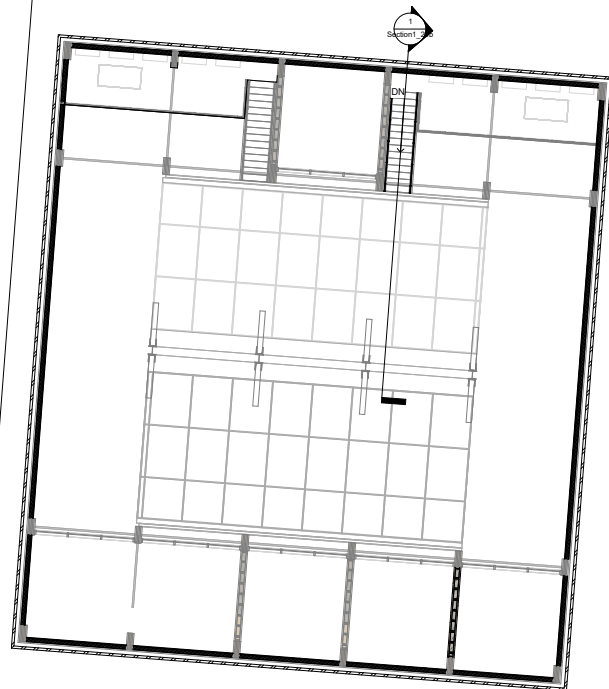
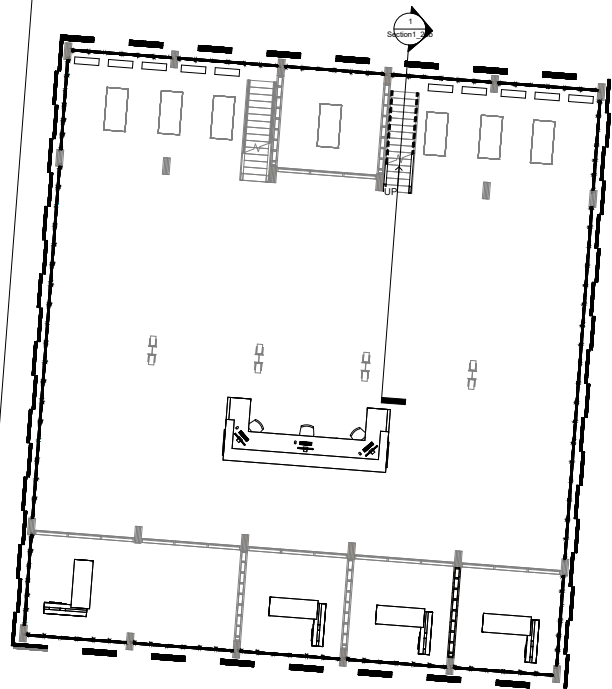
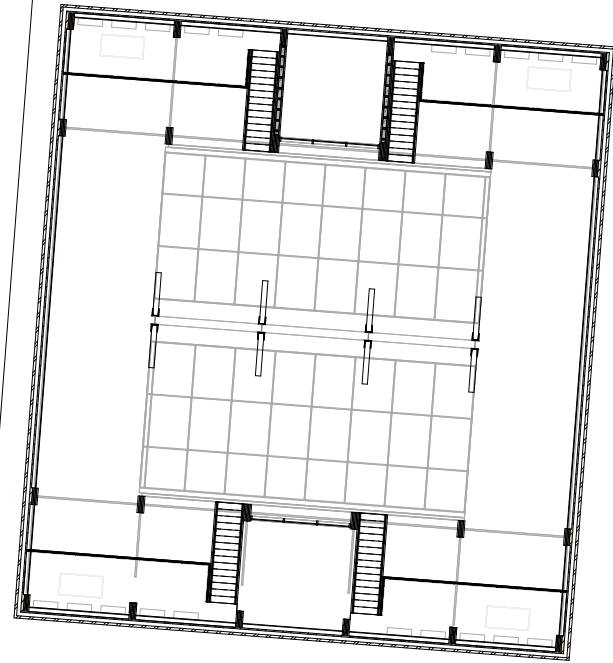
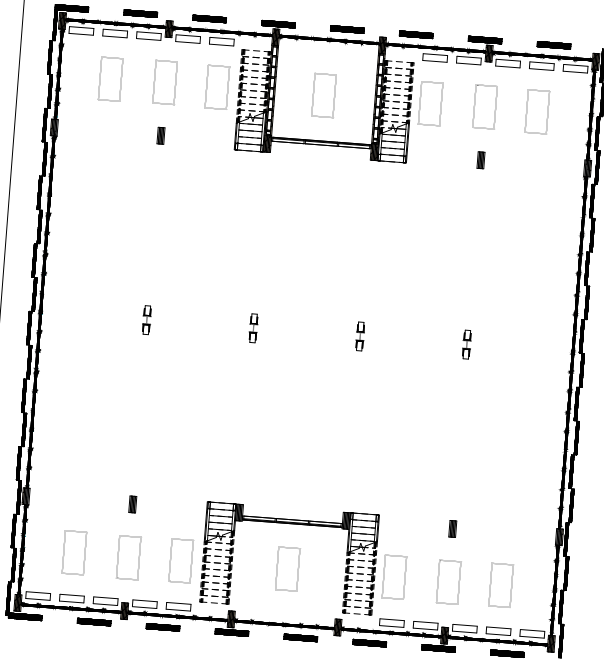

# 1:20 Facade Interior/Exterior

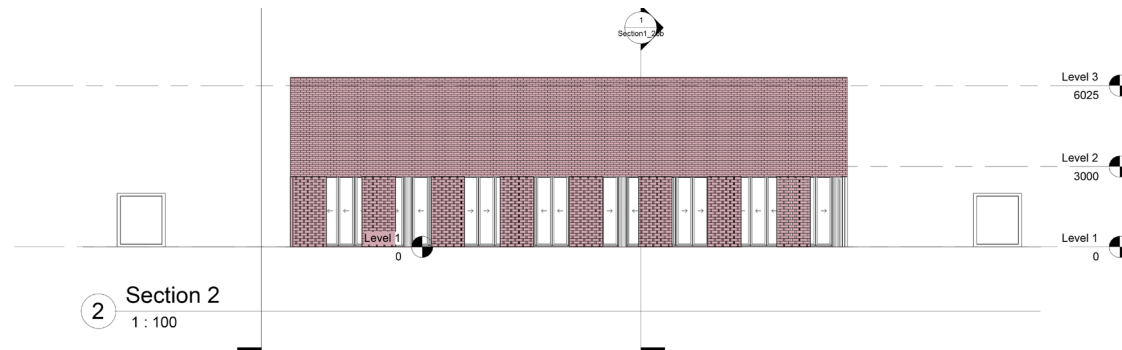
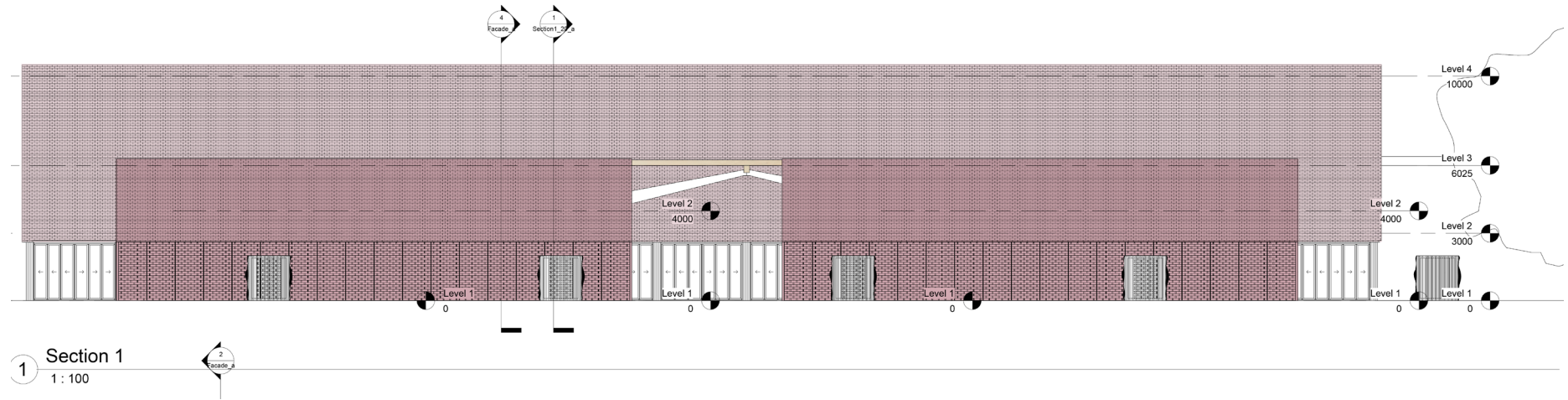





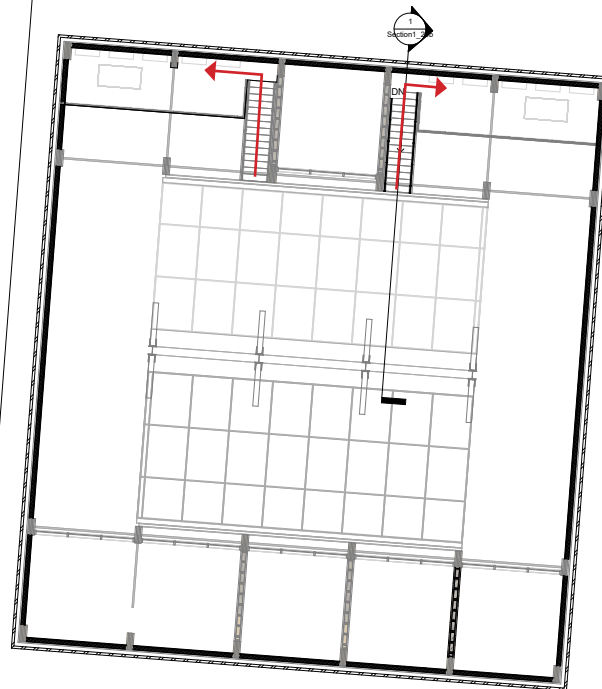
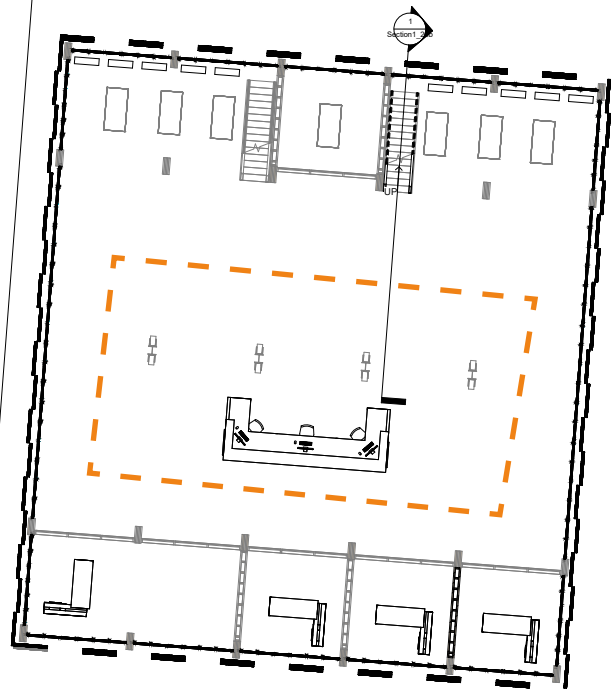
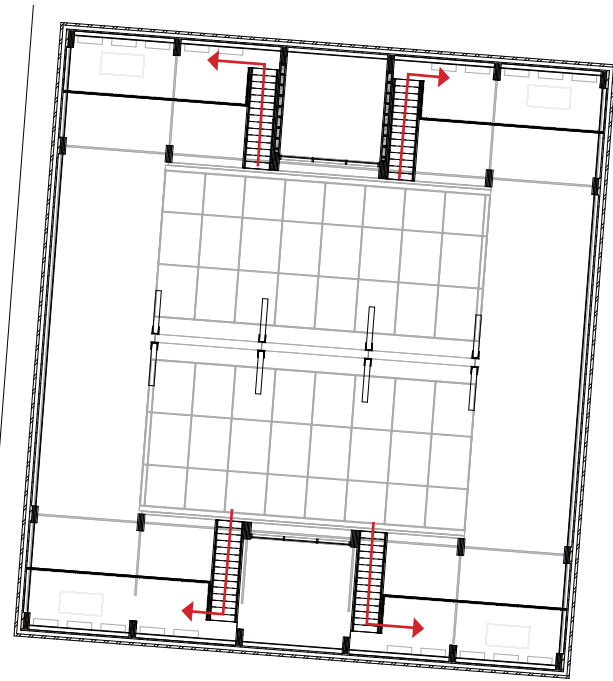
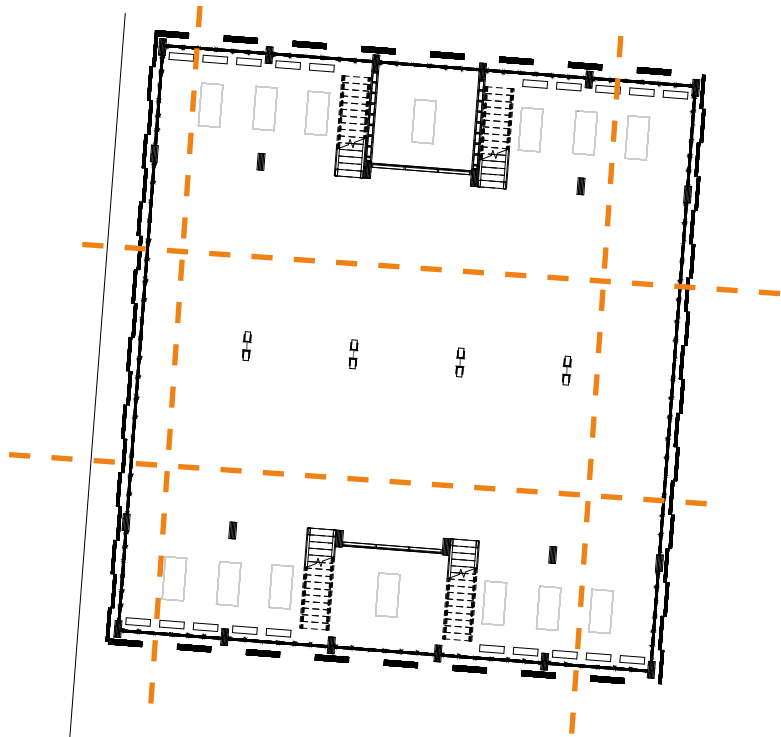

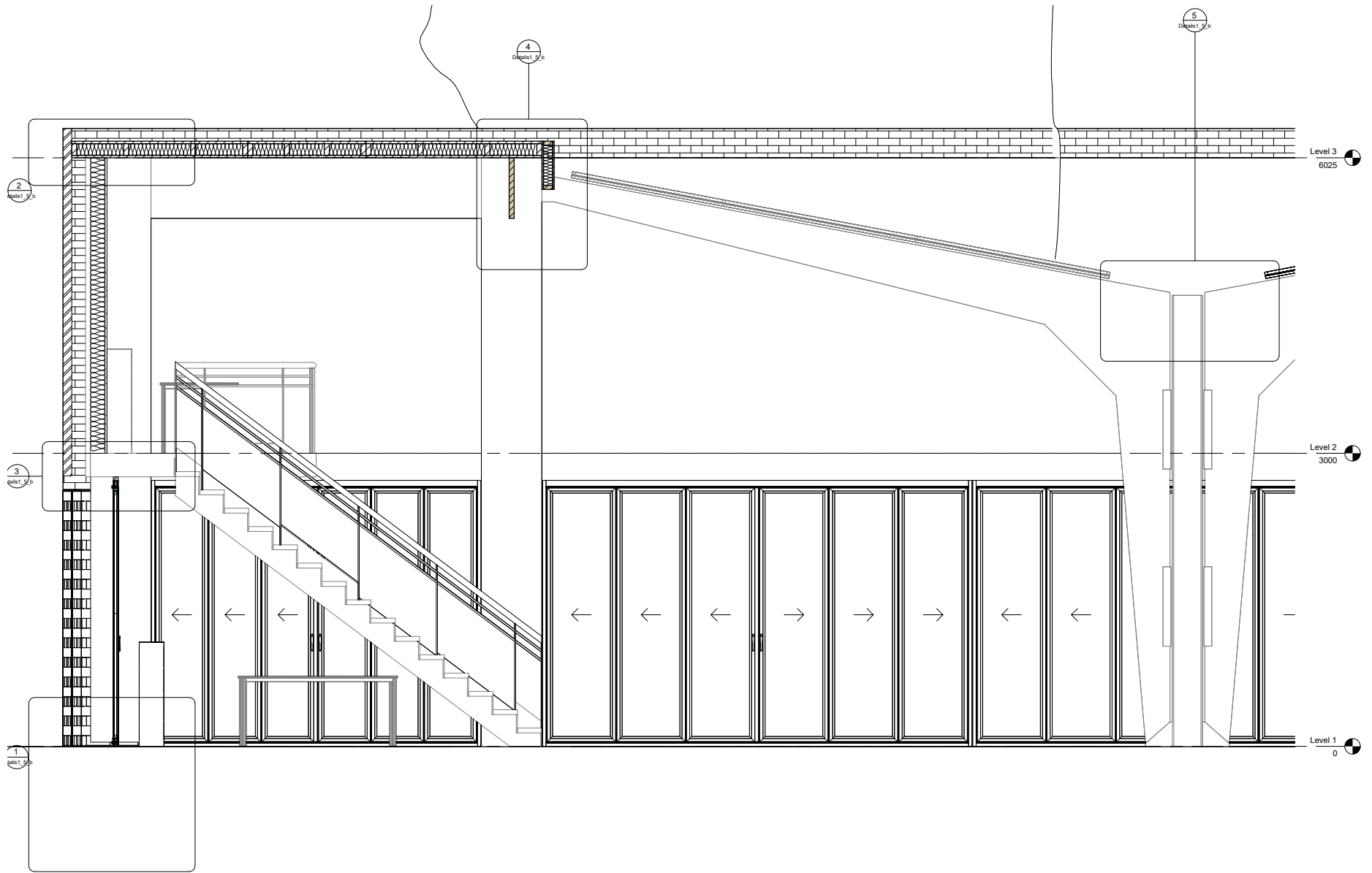

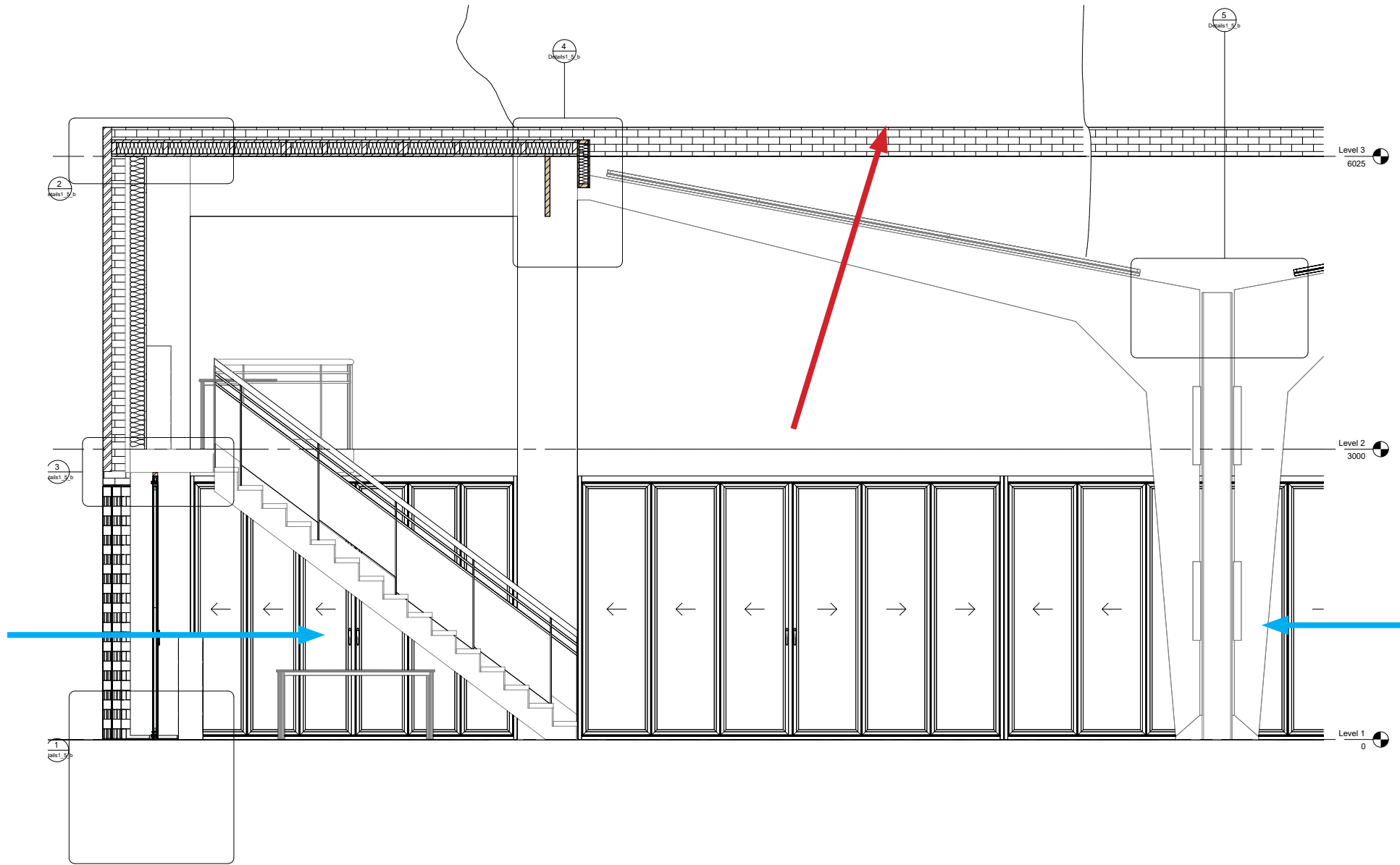

## RESEARCH QUESTION

“How can the Music Marvel, as a *transformative intervention tool*, act as a *cultural cohesive network* for Binckhorst that utilizes the present *historic artifacts*?”

