

Petri-net based cooperation modeling and time analysis of emergency response in the context of domino effect prevention in process industries

Zhou, Jianfeng; Reniers, Genserik

DOI

[10.1016/j.res.2022.108505](https://doi.org/10.1016/j.res.2022.108505)

Publication date

2022

Document Version

Final published version

Published in

Reliability Engineering and System Safety

Citation (APA)

Zhou, J., & Reniers, G. (2022). Petri-net based cooperation modeling and time analysis of emergency response in the context of domino effect prevention in process industries. *Reliability Engineering and System Safety*, 223, Article 108505. <https://doi.org/10.1016/j.res.2022.108505>

Important note

To cite this publication, please use the final published version (if applicable). Please check the document version above.

Copyright

Other than for strictly personal use, it is not permitted to download, forward or distribute the text or part of it, without the consent of the author(s) and/or copyright holder(s), unless the work is under an open content license such as Creative Commons.

Takedown policy

Please contact us and provide details if you believe this document breaches copyrights. We will remove access to the work immediately and investigate your claim.

Green Open Access added to TU Delft Institutional Repository

'You share, we take care!' - Taverne project

<https://www.openaccess.nl/en/you-share-we-take-care>

Otherwise as indicated in the copyright section: the publisher is the copyright holder of this work and the author uses the Dutch legislation to make this work public.

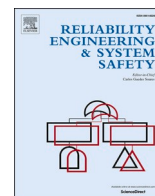

Petri-net based cooperation modeling and time analysis of emergency response in the context of domino effect prevention in process industries

Jianfeng Zhou^{a,*}, Genserik Reniers^{b,c,d}

^a School of Electromechanical Engineering, Guangdong University of Technology, Guangzhou 510006, China

^b Faculty of Technology, Policy and Management, Safety and Security Science Group (S3G), TU Delft, Delft 2628 BX, the Netherland

^c Faculty of Applied Economics, Antwerp Research Group on Safety and Security (ARGoSS), Universiteit Antwerpen, Antwerp 2000, Belgium

^d CEDON, KULeuven, Brussels 1000, Belgium

ARTICLE INFO

Keywords:

Emergency response actions
Timed colored Petri-net
Cooperation modeling
Time analysis

ABSTRACT

Emergency response is an important way to reduce losses after a major industrial accident occurs and mitigation measures should be arranged and analyzed in preparedness. The cooperation in emergency response actions which make up an emergency response process has a significant impact on the efficiency and success rate (or reliability) of emergency response, and improper arrangement of actions may reduce emergency response efficiency. As emergency response is characterized by rapid response, this work studies the success of emergency response based on time analysis. In this paper, cooperation modes of emergency response actions and their time characteristics are analyzed. A timed colored Petri-net (TCPN) based approach is proposed to model the cooperation of the actions and perform time analysis. The proposed approach is illustrated by an example of fire brigades' response to a tank fire. Simulations are performed and the probabilities of preventing fire escalation under different cooperation modes are analyzed. TCPN based modeling and analysis of emergency response actions are helpful for planning the necessary actions in the preparation of an emergency situation.

1. Introduction

Generally, risk analysis for industrial accidents focuses on the analysis of risks in two aspects: (i) the likelihood of an accident, and (ii) the possible consequences of the accident. Emergency response is very important as a mitigation measure, that is, for reducing the possible impact of unwanted events. As such, actually, a risk analysis should involve the analysis and assessment of the emergency response arrangements. Emergency response refers to the actions taken by people after an accident occurs, and the purpose of the emergency response is to reduce the loss caused by the accident. Fire is a common type of accident in industrial production. Some principles of emergency response in relation to fires are 'fire controlling before fire extinguishing' and 'saving people before saving property'. Therefore, our research in this paper concerns an impact analysis of emergency response with respect to fire escalation prevention.

However, emergency response to major industrial accidents is a complex process, being composed of many emergency response actions, and involving many personnel, departments and materials. These emergency response actions may influence each other, and in case of mutual hindering or worse still, some actions being wrong, inadequate

emergency response not only may not effectively reduce accident losses, but may even cause losses to expand. For example, on 12 August 2015, a fire broke out in the hazardous goods warehouse of an international logistics company located in the Tianjin Harbor of China [24]. Firefighters of the Port Fire Brigade first arrived at the scene within four minutes after receiving the fire alarm. However, the employees of the warehouse were not able to provide any helpful information about the stored substances. As a general approach, firefighters fought against the fire with water, which was wrong in this condition and led to an expansion of the flames. As the fire developed rapidly, firefighters asked for backup and evacuated the accident zone, but they kept spraying water to the containers in order to prevent the fire from propagating, which made the accident far worse. A minor explosion occurred followed by another much more violent one, resulting in six major fires and tens of small fires. The accident ultimately caused 165 fatalities including 24 firefighters and 11 police officers, 8 missing, 798 injured, and overall 304 buildings damaged. Another accident occurred on 17 April 2013, when a fire broke out at the West Fertilizer Company in West, Texas, USA [24]. Firefighters hastened to the scene to fight the fire. But soon an explosion occurred. The blast wave of the explosion destroyed buildings and knocked down walls. Twelve firefighters and

* Corresponding author.

<https://doi.org/10.1016/j.ress.2022.108505>

Received 28 September 2021; Received in revised form 6 February 2022; Accepted 27 March 2022

Available online 30 March 2022

0951-8320/© 2022 Elsevier Ltd. All rights reserved.

Table 1
Recent studies on emergency response efficiency.

Reference	Research question	Method used
Guo and Zhang [15]	Evacuation at metro stations	A simulation-based approach combining Light Gradient Boosting Machine with Non-dominated Sorting Genetic Algorithm III
Du et al. [9]	The evolution of an emergency response network over time	Social network analysis (SNA)
Du et al. [10]	Emergency resources allocation and scheduling	A mathematical model and a heuristic algorithm for calculation
Hou et al. [17]	Evacuation efficiency of the public	Statistical analysis
Zhou et al. [39]	Scheduling of fire trucks in major chemical fires	Simulation using eM-Plant
Bernier et al. [2]	Accessibility of petrochemical facilities to emergency personnel and workers with damage to transportation network	A scenario-based framework
Dulebenets et al. [11]	Driving performance under emergency evacuation	Statistical models
[4]	Evacuation efficiency	A computational model

three volunteers were killed, at least 250 people were injured and more than 150 buildings were damaged. The investigation of the accident showed that firefighters were not trained on firefighting strategies/tactics and emergency response to storage sites handling fertilizer of ammonium nitrate. In addition, the emergency scene operation was disorganized and under inadequate supervision due to no command system.

These cases show that emergency actions have a significant impact on the efficiency of emergency response. Many research works have been devoted to improving the efficiency of the emergency response process. Table 1 lists some studies on improving emergency response efficiency in recent years, which studied the problem from many different aspects, such as emergency resource allocation, emergency organization, and emergency evacuation. However, the emergency response process is composed of a series of actions, and different emergency actions need to cooperate with each other to achieve emergency response goals. Even for the same emergency actions, different cooperation modes may lead to different results in an emergency response. The methods shown in Table 1 are suitable for solving the corresponding problems, but most of them are not suitable for temporal analysis of emergency response actions, because they cannot reflect the temporal characteristics of different relationships among actions. The specific analysis of emergency response actions, and especially the analysis of time performance of them, is rarely involved in the literature.

A primary accident may escalate to one or more other accidents under the impact of escalation vectors, which are the physical effects of the primary accident that may result in the propagation, such as thermal radiation and overpressure. The phenomenon of accidents escalating from one installation to another is called a “domino effect”. Domino effects can cause great losses, so how to prevent domino effects or reduce the probability of domino effects is very important for risk/safety management and has been studied by some researchers, mainly in the analysis of safety barriers or safety measures, e.g., in the works of Reniers & Dullaert [32], Janssens et al. (2005) and Landucci et al. [19]. In addition to safety barriers, emergency response can play an important role in preventing domino effects.

There are some relationships among emergency response actions, such as ‘sequence’, ‘parallelism’ and so on, and Petri-nets are powerful tools for modeling these relationships. The notion of a Petri-net was proposed by Carl Adam Petri in 1962 [8]. Petri-net is a graphical modeling and analysis tool consisting of elements like places, transitions, arcs and tokens. Petri-net has become a popular mathematical and

graphical modeling tool used for concurrent systems modeling [30]. There are some extensions to basic Petri-net. For example, Timed Petri-net (TPN) assigns “firing times” to the transitions or places of a Petri-net, so that the duration of activities can be taken into consideration [40]. Colored Petri-Net (CPN) extends Petri-net with colors (data types), functions, and modules to model concurrency, synchronization, and data processing [18]. Timed colored Petri-net (TCPN) combines the advantages of TPN and CPN, and has been used in many fields [16,21]. Stochastic Petri net allows transitions to be executed after a stochastic time delay after being enabled [3,20].

Various forms of Petri-nets have been applied in many fields, and they are also used in the analysis of system reliability. For example, Elusakin and Shafiee [12] used stochastic Petri-net (SPN) and reliability block diagram (RBD) for reliability analysis of subsea blowout preventer systems. Taleb-Berrouane et al. [34] proposed a Bayesian Stochastic Petri-net for dynamic safety and reliability analysis. Chahrour et al. [3] used physics-informed stochastic Petri-nets to model deterioration and assess maintenance, so that safety, reliability and preventive maintenance can be analyzed. Li et al. [22] proposed a colored generalized stochastic petri net to evaluate the reliability of a cloud data center service. Petri-nets were also used to analyze the emergency response process, such as performance evaluation of the Urban Emergency Response System (UERS) (Zhong et al. [35], conflict of emergency actions and model liveness analysis [36], modeling and analyzing of emergency response process with uncertain activity execution duration, resource quantity, and resource preparation duration [23], key-tasks analysis of subway fire emergency response [21], analysis of fire escalation prevention considering safety measures including emergency response [38].

The typical characteristic of emergency response is to act quickly and to respond as soon as possible to reduce losses after an accident occurs. Thus, in this study, the success of the emergency response system is reflected by whether the corresponding emergency response actions can be completed within a given time. The cooperation in emergency response actions which make up an emergency response process has a significant impact on the efficiency and success rate (or reliability) of emergency response, and improper cooperation of actions may reduce emergency response efficiency. The cooperation of emergency response actions has received little attention in previous studies. The contribution of this work is that a TCPN based approach is proposed to model the cooperation of emergency response actions through basic immediate relationships between the actions and solve the time analysis problems based on time characteristics of cooperation modes, so as to perform reliability analysis of the emergency response process based on time analysis, such that arrangements for emergency actions can be analyzed in advance to help improve emergency preparedness. Although other types of Petri-nets can also be used to model an emergency response process, e.g., in previous studies, timed colored hybrid Petri-net (TCHPN) [37] and probabilistic Petri-net [38] were used to analyze emergency response, this work does not consider hybrid actions and some probabilistic relationships between actions are not easily handled directly by PPN, TCPN is adopted as a modeling tool.

The remaining parts of this paper are organized as follows: Section 2 discusses the cooperation of actions that may impact on the emergency response. Section 3 provides the definition of TCPN and the cooperation modeling approach of emergency response actions, and discusses time analysis problems and solutions. An illustrative example is provided in Section 4. Conclusions are drawn in Section 5.

2. Cooperation of emergency response actions

In an emergency response process, there are many emergency response actions. Each action may complete a task, and all actions together achieve the emergency response target. There are three basic relationships between emergency response actions which will impact on the cooperation of them.

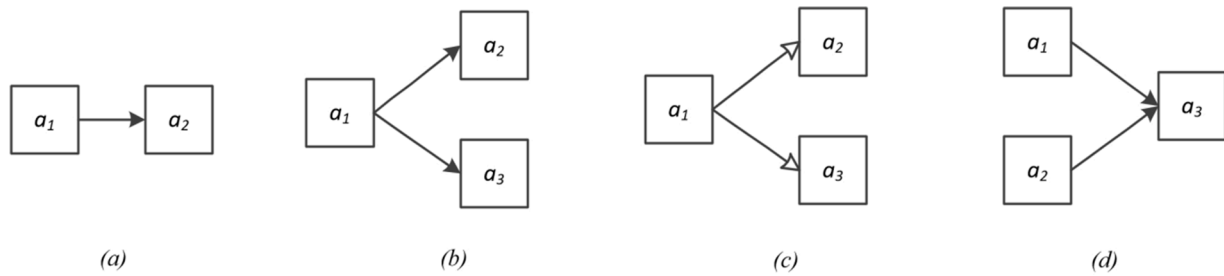

Fig. 1. Immediate relationship between emergency response actions.

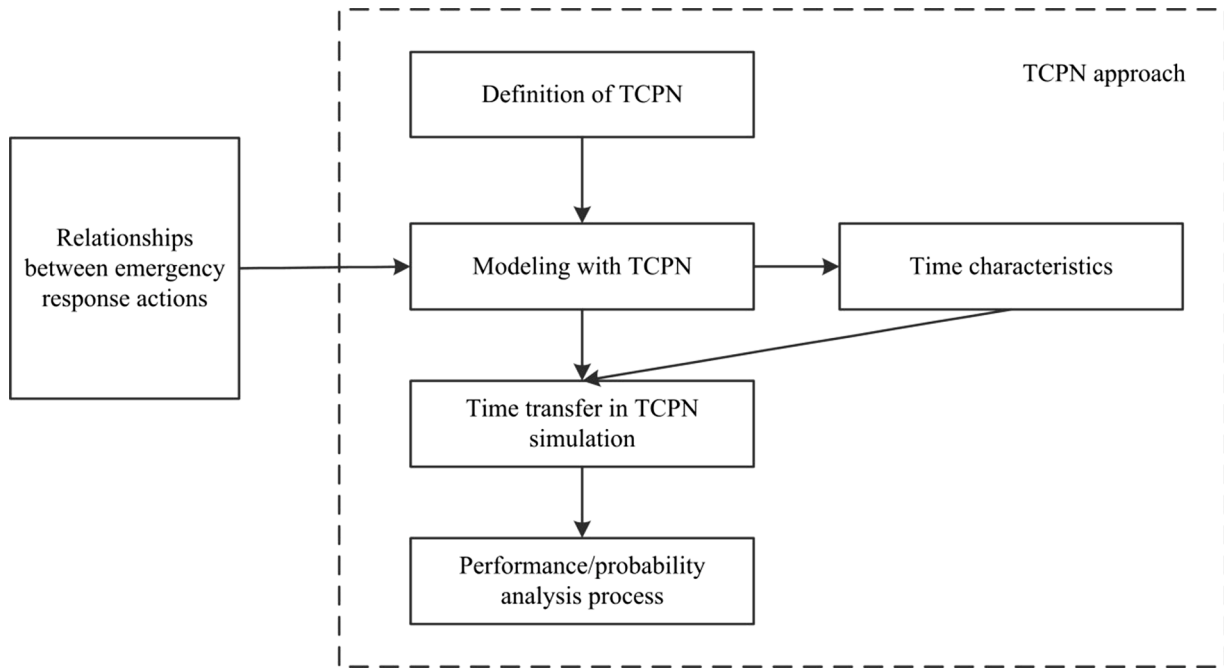

Fig. 2. The main content of the TCPN method and the relationship between its parts.

(i) Sequential actions

Emergency response actions are performed one after another, and the emergency response action behind has to wait for the completion of the emergency response action ahead.

(i) Parallel actions

Emergency response actions are performed in parallel. They may not interact with each other, but they may influence each other. There is a complex relationship between them. This will be discussed later.

(i) Selective actions

Among several emergency response actions, one action is chosen to be carried out. Obviously, there is no interaction between these actions during the execution after an action is selected.

It is difficult to determine the relationship between any two actions in an emergency response process, but the relationship can be revealed through pre and post-actions of an emergency response action. Fig. 1 shows the immediate relationship between actions. Fig. 1 (a) indicates the sequential relationship, a_1 is the immediate pre-action of a_2 and a_2 is the immediate post-action of a_1 . Fig. 1 (b) represents the parallel relationship of actions a_2 and a_3 , actions a_2 and a_3 have the same immediate pre-action a_1 and a_1 has two immediate post-actions a_2 and a_3 . Fig. 1 (c) shows the selective relationship of actions a_2 and a_3 , actions a_2 and a_3

have the same immediate pre-action a_1 and a_1 has two immediate post-actions a_2 and a_3 . The hollow arrow in Fig. 1 (c) indicates that the execution of a pointing action depends on the choice. Fig. 1 (d) shows that actions a_1 and a_2 have the same immediate post-action a_3 , this means that after the execution of a_1 or a_2 , action a_3 can be executed.

For action a_i , action a_j is an immediate pre-action of a_i when a_i has to start at the end of a_j , and action a_j is a pre-action of a_i when emergency response actions can be performed from action a_j to action a_i . Similarly, for action a_i , action a_j is an immediate post-action of a_i when a_j has to start at the end of a_i , and action a_j is a post-action of a_i when emergency response actions can be performed from action a_i to action a_j . Denote immediate pre-actions of action a_i as ${}^{\circ}a_i$, and pre-actions of a_i as $*a_i$; denote immediate post-actions of action a_i as a_i° , and post-actions of a_i as a_i^* .

3. Petri-net based analysis approach

To model the relationships between emergency actions, Petri-net is introduced in this work. In order to facilitate the handling of different states and times of actions, the timed colored Petri-net (TCPN) is adopted. The main content of the TCPN based approach is shown in Fig. 2.

Firstly, the formal definition of TCPN is given, including enabling and execution rules of transitions; then the TCPN is used to model the cooperation of emergency actions and the main patterns are discussed; after that the temporal characteristics of various cooperation patterns,

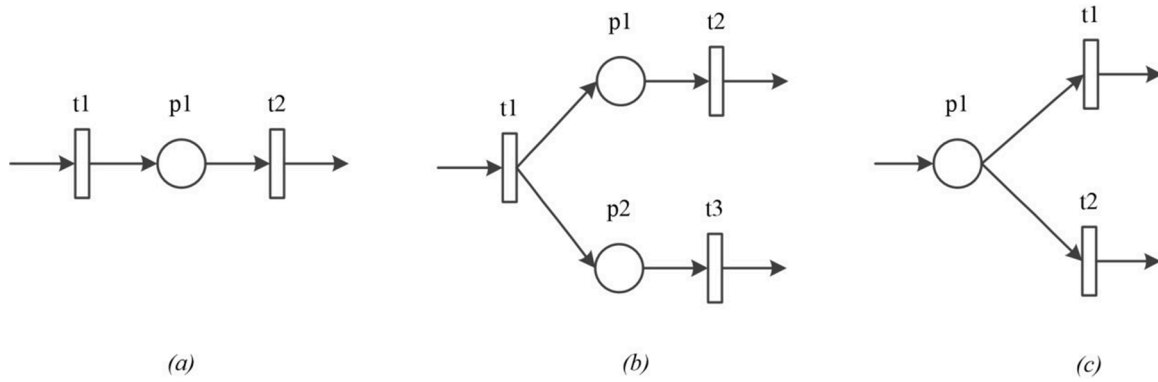

Fig. 3. Cooperation modeling of emergency actions: (a) modeling of sequential actions. (b) modeling of parallel actions (t_2 and t_3). (c) modeling of selective actions.

especially the parallel relationships between actions, are analyzed. The quantitative analysis using Petri-net is mainly based on simulation, and thus how to transfer the time information in a TCPN simulation, is then presented. At last, the process (flowchart) of the performance/probability analysis of an emergency response in a given time is discussed. The main issue expounded upon is about how to use Monte-Carlo Simulation to carry on the probability analysis in a TCPN based analysis.

3.1. Definition

Based on the definition of timed colored hybrid Petri-net (TCHPN) in Zhou and Reniers [37], the Timed Colored Petri-Net (TCPN) is defined as an eleven-tuple:

$$TCPN = (P, T, A, \Omega, V, N, C, G, E, In, \tau)$$

- (1) P : is a finite set of places. A place can hold tokens with or without colors.
- (2) T : is a finite set of transitions. T can also be split into two subsets T_T and T_I , respectively, representing the timed and immediate transitions. The timed transitions have certain execution duration, while the immediate transitions execute immediately (their execution durations are zero).
- (3) $A \subseteq P \times T \cup T \times P$: indicates arcs connecting places to transitions and transitions to places.
- (4) Ω : denotes color sets, which can be considered as a set of non-empty types.
- (5) V : indicates variable types, satisfying $Type[v] \in \Omega$ for all $v \in V$ variables. Where, $Type(expr)$ denotes the type of an expression.
- (6) $N: A \rightarrow P \times T \cup T \times P$ is a node function.
- (7) $C: P \rightarrow \Omega$ is a function that assigns a color set to each place.
- (8) G : represents guard function which assigns a guard to each transition t .

$$\forall t \in T : [Type(G(t)) = Bool \wedge Type(Var(G(t))) \subseteq \Omega]$$

A guard is used to filter and restrict possible events.

- (1) E : represents the arch expression function, which assigns an arc expression to each arch.

$$\forall a \in A : [Type(E(a)) = C(p(a))_{MS} \wedge Type(Var(E(a))) \subseteq \Omega]$$

where, $p(a)$ is the place of $N(a)$.

- (1) In : is an initialization function.

$\forall p \in P: [Type(In(p)) = C(p(a))_{MS} \wedge Var(In(p)) = \emptyset]$ where: $Var(expr)$ gets the variable set in an expression, $C(p)_{MS}$ denotes a multi-set over $C(p)$.

- (1) τ : is a set of nonnegative real numbers representing time delays of transitions. As transitions represent emergency response actions in this work, the delay time (duration) of a transition indicates the executing time of the corresponding emergency response action.

A token in the Petri-net is considered as a pair (p, c) , for $p \in P$ and $c \in C(p)$. Let $B(t)$ denote the set of all bindings for t , so a binding element can be defined as a pair (t, b) , for $t \in T$ and $b \in B(t)$. A binding is a set of variables required by transition t . M is the marking of a TCPN, representing the state of the TCPN, and M_0 indicates the initial marking. $M_i(p)$ can represent the number of tokens with colors in place p , for $i \in \mathbb{N}$ (Natural number).

In the following parts of this paper, $\bullet t$ ($\bullet p$) denotes input places of transition t (input transitions of place p) and $t \bullet$ ($p \bullet$) represents output places of transition t (output transitions of place p).

A transition is enabled if all its input places contain the multi-set specified by their input arc, and the evaluation of the guard is true. That is, transition t with binding b is enabled in a marking M_i if and only if

- i $G(t) \langle b \rangle = True$
- ii $E(p, t) \langle b \rangle \leq M_i(p), \forall p \in \bullet t$

This means that a transition is enabled if and only if (1) The guard is true, and (2) The tokens (of the correct colors in each input place) are enough.

A transition can fire/execute if it is enabled. At the beginning of its execution, it removes tokens specified by the input arc from its input places. When its delay time is satisfied, it puts tokens specified by the output arc into its output places. Thus, execution of an enabled transition t at marking M_i changes the marking into M_{i+1} . The execution result is the following

$$M_{i+1}(p) = (M_i(p) - E(p, t) \langle b \rangle + E(t, p) \langle b \rangle), \forall p \in P \quad (1)$$

The elements in TCPN are represented as icons, in which places are denoted by circles, transitions are denoted by rectangles (timed transitions are denoted by hollow rectangles, and immediate transitions are denoted by solid rectangles), arcs are represented by arrows, and tokens are represented by dots or numbers. An arrow can have expressions to limit the color or number of tokens required by corresponding transitions, the default expression indicates one normal token (it can have no color).

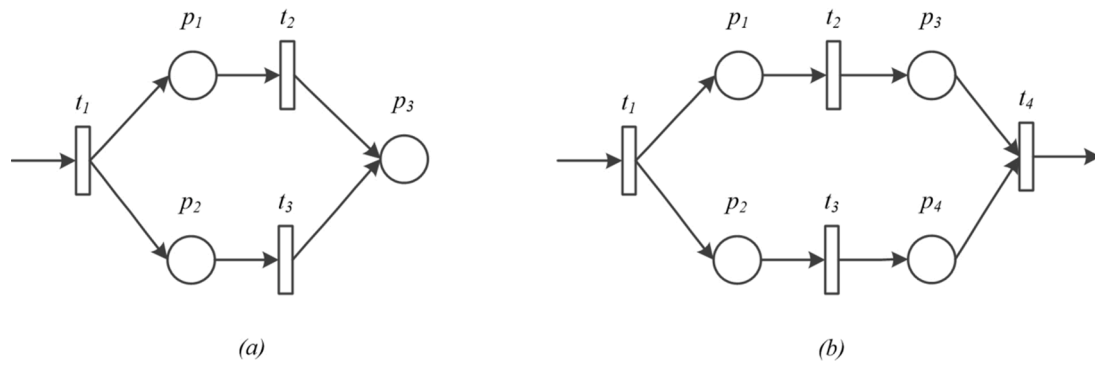

Fig. 4. Parallel actions in two conditions: (a) they have the same output state; (b) they have different output states.

3.2. Cooperation modeling of emergency response actions

Fig. 3 shows the cooperation modeling of emergency response actions. Fig. 3 (a) illustrates two actions being executed in sequence, where the execution of t_2 has to wait until the execution of t_1 is over and a token is put into place p_1 .

In Fig. 3 (b), actions represented by t_2 and t_3 are executed in parallel. The execution of t_2 and t_3 does not influence each other.

Fig. 3 (c) demonstrates two selective actions. Both executions of t_1 and t_2 rely on the token in place p_1 . This usually causes conflict between t_1 and t_2 . To avoid the conflict, a color should be used to distinguish different situations which thus enable different transitions.

3.3. Time characteristics of cooperation modes

For convenience, denote the duration of t_i as d_i in the following discussion.

(i) Sequential actions

For sequential emergency response actions, the total duration is the sum of the durations of them. Suppose there are k sequential emergency response actions, which are modeled by t_1, t_2, \dots, t_k of Petri-net, the total duration d of these actions is

$$d = \sum_{i=1}^k d_i$$

(ii) Selective actions

For selective emergency response actions, the duration of them depends on the selection of the actions. If an action is selected from k selective emergency response actions, which are modeled by t_1, t_2, \dots, t_k , the final duration d is

$$d = d_i \text{ if } t_i \text{ is selected}$$

(iii) Parallel actions

Determining the duration of parallel actions is more complex. The follow-up actions and states may have an impact on the duration. Some conditions that impact on the duration of parallel actions are discussed below.

Aiming at the Petri-net model of parallel actions shown in Fig. 3 (b), the duration of parallel actions is very different in two different conditions shown in Fig. 4 (a) and (b). In Fig. 4 (a), parallel transitions t_2 and t_3 connect to the same output place p_3 . If place p_3 represents a state of the execution of t_2 or t_3 , the action with shorter duration will reach this state sooner. Thus, the smallest duration of the parallel actions is adopted as the duration of them. For example, after an accident occurs, the valves of an installation should be closed. Two ways are carried out to close the valves of a pipe of the installation at the same time, one is to shut down the automatic valve through the control system, and the other is to manually close the manual valve. If either of the two valves is closed, the pipe will be closed. In this case, the smaller duration of the two actions determines the duration of the parallel actions.

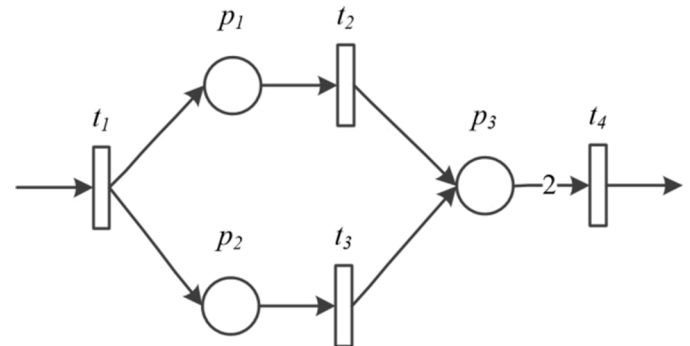

Fig. 5. Duration of parallel actions impacted by the following transition.

In Fig. 4 (b), the parallel transitions t_2 and t_3 have different output places p_3 and p_4 , respectively, and they have the following transition t_4 . The enabling of transition t_4 needs tokens both in p_3 and p_4 . As the longer duration of t_2 and t_3 determines the enabling and execution time of t_4 , the duration of the parallel actions in this condition is the maximum of the durations of the actions. For example, in an evacuation process, the evacuees must get to the pick-up point to take a vehicle; on the other hand, the vehicle should be driven to the pick-up point to pick up the evacuees. These two actions (“evacuees run to the pick-up point” and “the vehicle is driven to the pick-up point”) are executed in parallel. However, the evacuation has to wait until both the vehicle and the evacuees arrive at the pick-up point. In this case, the longer duration of the two actions determines the duration of the parallel actions.

If the token in a place does not represent a state, but the number of objects or persons, the tokens required by the enabling and executing of following transitions may also influence the duration of parallel actions. The model shown in Fig. 4 (a) is adapted to represent another condition which is shown in Fig. 5. Suppose that the tokens in this model represent persons, and each action represented by t_2 and t_3 needs one person, the action represented by t_4 needs 2 persons. Transition t_4 can be enabled only if both t_2 and t_3 are finished and two tokens (persons) are put into place p_3 . In this condition, the larger duration of the two parallel actions determines the duration of them. If the enabling and execution of transition t_4 only need one token (person) in place p_3 , this is the same as the condition shown in Fig. 4 (a) and the duration of the two parallel actions is the smaller one of them.

It can be seen from the discussion that it is difficult to formally describe the duration of parallel actions. Nevertheless, Petri-nets provide a mechanism to analyze dynamic activities of a system using tokens. During the execution of each transition, it removes tokens from input places according to input arc inscriptions, and generates required tokens in output places. Thus, time information can be transferred transition by transition using the tokens.

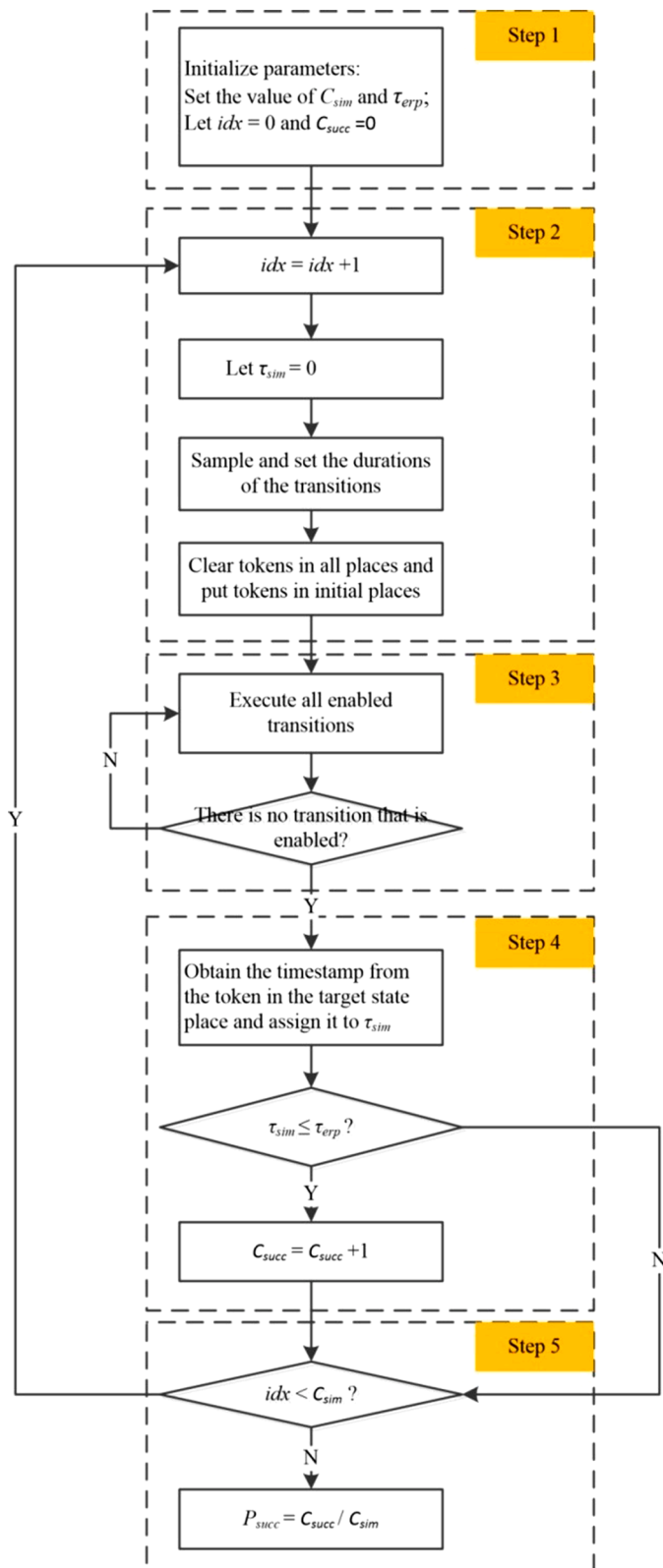

Fig. 6. Steps of emergency response performance analysis.

3.4. Time transfer in TCPN simulation

The simulation based on a Petri-net is done by the execution of transitions, which removes tokens from input places and generates tokens in output places to enable the subsequent transitions to execute, as if tokens “flow” in the net. In a timed Petri-net, durations of transitions

can be transferred by the tokens.

In this study, each token is assigned a timestamp attribution, e.g. named with ‘creationtime’, to record its creation time. Let Tok be the function of a place and $Tok(p)$ represents tokens in place p . Thus, execution of an enabled transition t at marking M_i changes the marking into M_{i+1} , and the execution rule shown as Eq. (1) can be replaced by the following execution rules of enabled transition t :

(i) At the beginning of the execution

$$\forall p \in \bullet t,$$

$$Ltime(p) = \text{Remove}(\text{Sort}(Tok(p)), E(p, t) < b >) \quad (2)$$

$M_{i+1}(p) = (M_i(p) - E(p, t) < b >)$ where, Sort is a function that sorts tokens in ascending order according to their timestamps. Remove is a function that deletes tokens from a place and returns the latest time of the deleted tokens. $Ltime(p)$ means the latest time of the removed tokens of place p .

Eq. (2) means that at the beginning of the execution of transition t , it deletes first $E(p, t) < b >$ tokens from place p , according to the timestamp in ascending order, and get the latest time of first $E(p, t) < b >$ tokens.

(ii) At the end of the execution

$$Ltime = \max(Ltime(p)), \text{ for } p \in \bullet t, \text{ and } \forall p \in t,$$

$$\text{Create}(p, E(t, p) < b >, Ltime + \tau(t)) \quad (3)$$

$$M_{i+1}(p) = (M_i(p) + E(t, p) < b >),$$

Where, $Ltime$ represents the beginning time of the execution of transition t . Create is a function that creates $E(t, p) < b >$ tokens in place p , and assigns the timestamp determined by $Ltime + \tau(t)$ to them. $\tau(t)$ is the duration of transition t .

3.5. Time based performance/probability analysis

During an emergency response to an accident, the response time is very important to reduce possible losses. If precious time is lost to control an accident, escalation may occur and even greater consequences might be the result.

After an emergency response time is given, the performance of the emergency response actions can be analyzed through simulation based time analysis using the TCPN model of the emergency response process. If the duration of an emergency response is less than the required time, we can assume that this emergency response is successful. The steps of the probability analysis of successful emergency response are shown in Fig. 6.

Step 1: Initialize parameters influencing the overall analysis process. C_{sim} is the number of simulations. τ_{erp} is the required emergency response time. idx is the sequence number of simulations. C_{succ} is the number of successful emergency responses.

Step 2: Initialize parameters of the simulation analysis of an emergency response. This step includes the following tasks: (i) set the value of idx ; (ii) reset the value of τ_{sim} which indicates the duration of an emergency response to zero; (iii) sample durations according to certain distribution functions and set them to transitions; (iv) clear tokens in all places and set correct tokens in initial places which satisfy $\bullet p = \emptyset$.

Step 3: Execute all enabled transitions until there is no transition that is enabled or the target state place gets the required token. This process is based on the enabling and executing rules of transitions and the elapsed times are transferred through the “flowing” of tokens.

Step 4: Obtain the timestamp from the token in the target place and assign it to τ_{sim} , which represents the duration from the start of the emergency response to the point that the target state is reached. If the value of τ_{sim} is less than or equal to that of τ_{erp} , it means that the emergency response is successful and C_{succ} is added by one.

Step 5: Judge whether idx is less than C_{sim} . If idx is less than C_{sim} , then go back to Step 2 to do another simulation, otherwise, estimate the probability of successful emergency response:

$$P_{succ} = C_{succ} / C_{sim}$$

Table 2
Main emergency response actions for the tank fire accident.

Action	Immediate pre-action	Immediate post-action	Action	Immediate pre-action	Immediate post-action
Discover fire and report to the fire department (a_1)	\emptyset	a_2	Supply water from a distance (a_7)	a_6	a_{10}
Dispatch emergency response personnel (a_2)	a_1	a_3, a_4	Prepare cooling facilities (a_8)	a_6	a_{11}
Fire brigade 1 drives to the scene (a_3)	a_2	a_5, a_6	Prepare firefighting facilities (a_9)	a_6	a_{12}
Fire brigade 2 drives to the scene (a_4)	a_2	a_5, a_6	Prepare cooling water and extinguishing agents (a_{10})	a_6 or a_7	a_{12}
Measure fire state (a_5)	a_3 or a_4	a_6	Cooling begins (a_{11})	a_8 and a_{10}	\emptyset
Make decision and assign tasks (a_6)	$(a_3$ or $a_4)$ and a_5	$(a_7$ or $a_{10}), a_8, a_9$	Firefighting begins (a_{12})	a_9 and a_{10}	\emptyset

4. An illustrative example

In practice, there are usually many emergency response departments involved in the emergency response following a major accident. For example, on August 29, 2011, a fire occurred in the tank farm of PetroChina Company Limited (“PetroChina”) Dalian branch. After receiving the fire alarm, the fire brigades were immediately dispatched. The fire brigade of PetroChina Dalian Branch arrived at the scene first, and the other 19 fire squadrons with 73 fire trucks of Dalian City then arrived at the scene. They cooperated with each other to fight against the fire, and the fire was extinguished 3 h later. Based on this case, an example of an emergency response to a tank fire is established to illustrate the proposed approach.

It is assumed that a tank fire accident occurs in an atmospheric tank farm storing flammable liquids, e.g. hydro-carbons. Two fire brigades send out 6 emergency teams in total (suppose each brigade has 3 teams) to fight the fire. In this example, a team is taken as the unit of emergency response. When they arrive at the fire scene, one of the teams must measure and evaluate the fire first, and then all the teams are assigned tasks, for example, two teams try to cool adjacent tanks, two teams try to extinguish the fire, and the remaining two teams prepare fire water and fire extinguishing agents. For the two teams of cooling, they need to prepare the cooling equipment and put them in right places. Only when fire water and the cooling equipment are ready, the cooling action can begin. Similarly, the two firefighting teams need to prepare the firefighting equipment and deploy them to appropriate locations. Only when the preparation of fire extinguishing agents and firefighting equipment is finished, the firefighting can start. Emergency actions responding to this tank fire are listed in Table 2.

After the fire occurs, escalation of the fire to other installations is

possible in the course of the emergency response. The escalation vector that may cause the escalation for a fire mainly is thermal (heat) radiation [31], and fire is one of the most likely initial accidents to cause domino effects [1,7]. The failure time of an installation under the action of thermal radiation of a fire is relatively long, so that timely emergency response has the potential to prevent a potential fire escalation.

To analyze the probability of the fire escalation, it is necessary to estimate the thermal radiation received by the surrounding installations. We assume (for sake of simplicity) the nearby installations to be storage tanks. There are several models that can be used to analyze the thermal radiation of a fire. The commonly used fire thermal radiation models are the point source model, and the solid flame radiation model. The point source model considers that the thermal radiation released from a fire comes from a point in the center of the flame [25,26]. The solid flame radiation model idealizes a fire as a solid vertical cylinder whose sides emit thermal radiation. In addition, some other models can be used for thermal radiation estimation, for example, the two zone entrainment model [13], the Computational Fluid Dynamics (CFD) based model [5], and so on.

Under the thermal radiation effect of a fire, the neighboring installations (e.g. tanks) may fail. The time to failure (*ttf*) can be determined according to the relationship between received thermal radiation *I* (kW/m²) and *ttf* (s) provided by Cozzani et al. [6]:

$$\text{Atmospheric vessels: } \ln(\text{ttf}) = -1.128 \times \ln(I) - 2.267 \times 10^{-5}V + 9.877$$

$$\text{Pressurized vessels: } \ln(\text{ttf}) = -0.95 \times \ln(I) + 8.85 \times V^{0.032}$$

Where, *V* is the volume of the installation (m³).

If the duration that an installation is exposed to a thermal radiation is greater than the *ttf* of this installation, the installation is possible to be damaged. If emergency teams arrive at the fire scene within the time of

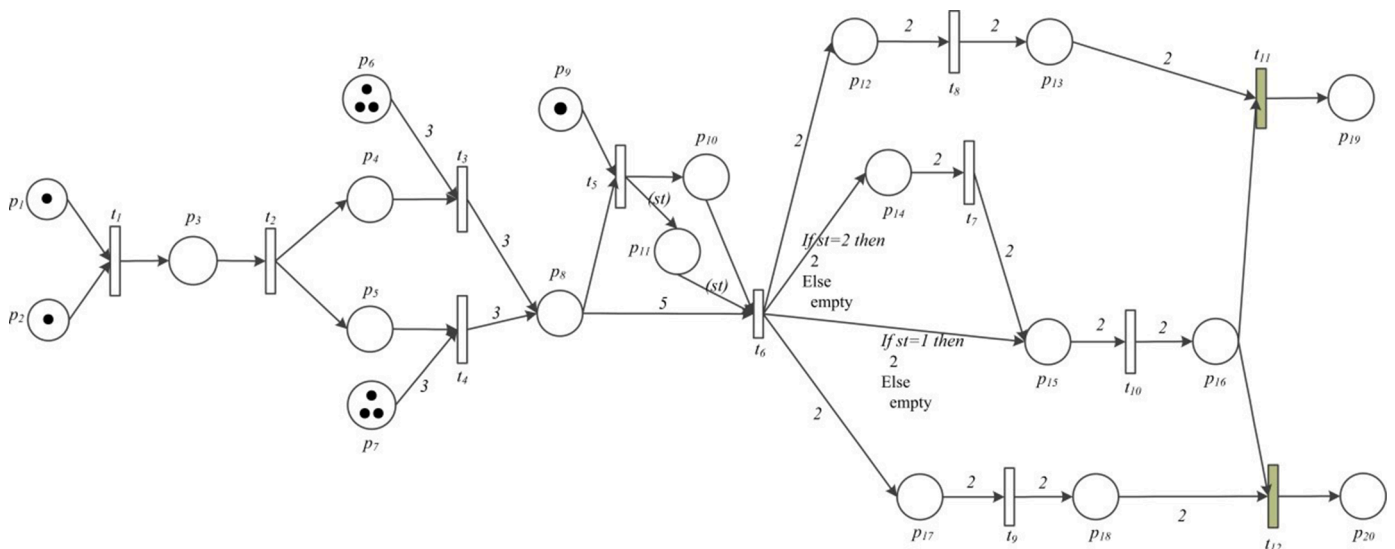

Fig. 7. TCPN model of an emergency response process.

Table 3
Places and their meaning of the emergency response TCPN model.

Place	Meanings	Place	Meanings
p_1	A tank is on fire	p_{11}	Fire state
p_2	There are workers in the area	p_{12}	Task is received by cooling teams
p_3	Fire alert has been received by the fire department	p_{13}	Cooling facilities are ready
p_4	Task is received by fire brigade 1	p_{14}	Task for supplying water from a distance
p_5	Task is received by fire brigade 2	p_{15}	Task for cooling water and fire agents preparation
p_6	Fire brigade 1 is on standby	p_{16}	Cooling water and fire agents are ready
p_7	Fire brigade 2 is on standby	p_{17}	Task is received by firefighting teams
p_8	Arrived at the scene	p_{18}	Firefighting facilities are ready
p_9	Fire state is unknown	p_{19}	Neighboring tanks are under cooling
p_{10}	Fire team finishing measuring fire state	p_{20}	Firefighting is started

Table 4
Transitions and their meaning of the emergency response TCPN model.

Transition	Meanings	Transition	Meanings
t_1	Discover the fire and report to the fire department (a_1)	t_7	Supply water from a distance (a_7)
t_2	Dispatch emergency response personnel (a_2)	t_8	Prepare cooling facilities (a_8)
t_3	Fire brigade 1 drives to the scene (a_3)	t_9	Prepare firefighting facilities (a_9)
t_4	Fire brigade 2 drives to the scene (a_4)	t_{10}	Prepare cooling water and extinguishing agents (a_{10})
t_5	Measure and evaluate fire state (a_5)	t_{11}	Cooling begins (a_{11})
t_6	Make decision and assign tasks (a_6)	t_{12}	Firefighting begins (a_{12})

ttf and take appropriate firefighting actions, e.g. cooling neighboring installations, the escalation that might be caused by an initial fire accident, will be prevented.

The TCPN model of this emergency response process is established as shown in Fig. 7. The meanings of places are listed in Table 3, and the meaning of transitions are listed in Table 4, where t_i corresponds to that of action a_i in Table 2, indicating that the corresponding emergency response action is mapped to the transition in the TCPN model. The number on arcs represents the number of tokens required for transition execution, and the dots in places represent tokens. This example only analyzes the process from the occurring of a fire to the beginning of firefighting/cooling.

The time to failure (ttf) of an installation which is exposed to a fire is the duration between the start of the fire and the failure of the installation, it represents the ‘resistance’ of the installation to external fires. Therefore, the time to failure can be taken as an important parameter to measure the efficiency of emergency response. In the example modeled in Fig. 7, if the duration from the start of a fire to the beginning of the cooling is longer than ttf , the emergency response can be considered a failure, because the neighboring tanks are likely to fail and, conversely,

Table 5
Mean duration of transitions.

Transition	Mean duration (minute)	Transition	Mean duration (minute)
t_1	1.5	t_2	2
t_3	3.5	t_4	5
t_5	2	t_6	1.5
t_7	3	t_8	2.5
t_{10}	2	t_{11}	3

the domino effect will be prevented, that is, if the tokens in initial places have a timestamp of zero, when place p_{19} obtains a token, the timestamp of the token is the duration to prevent domino effects and it can be utilized to judge whether the emergency response process is successful.

To illustrate the selective actions, a state place, p_{11} , is used in the model to indicate the measured state of the fire. When emergency personnel arrive at a fire site, they usually need to evaluate the fire situation and make corresponding decisions, including the type of materials on fire, storage volume, adjacent tanks, distribution and opening state of pipelines, firefighting facilities and so on in the fire area. Two states for water supply on the fire site are considered in this study, one is that there are (sufficient) fire water supply facilities on the site, and the other is that there are not (enough) water supply facilities at the site. The latter state requires an additional action to draw water from a distance, while the former does not. A color of INT type is used to distinguish the two states, and ‘st’ is the corresponding color variable. A value of 1 for ‘st’ indicates that there are (sufficient) water supply facilities at the site, and a value of 2 for ‘st’ indicates there are not (enough) water supply facilities at the site. Although the model itself does not need place p_{10} and the execution of the model will not be influenced without it, in order to describe the physical meanings clearly, p_{10} is used to represent the firefighters (emergency team), and p_{11} is used to represent the measured state.

As an illustrative example, the model in Fig. 7 contains the relationships of emergency actions shown in Fig. 1 and the corresponding Petri-net models shown in Figs. 3–5. Transitions t_1 and t_2 reflect the sequential actions, corresponding to the relationship of Fig. 3 (a). Transitions t_3 and t_4 represent a parallel relationship, and they have the same output place p_8 . For transition t_5 , the relationship between t_3 and t_4 corresponds to the model of Fig. 4 (a), transition t_5 can be enabled to execute when any of t_3 and t_4 finishes its execution. But for transition t_6 , the relationship between t_3 and t_4 corresponds to the model shown in Fig. 5, because the enabling and execution of t_6 requires that the executions of t_3 and t_4 (and t_5) have been completed. Process $t_6 \rightarrow t_8 \rightarrow t_{11}$ and process $t_6 \rightarrow t_{10} \rightarrow t_{11}$ (or $t_6 \rightarrow t_7 \rightarrow t_{10} \rightarrow t_{11}$) are also parallel, but corresponding to the model shown in Fig. 4 (b), transition t_{11} is not enabled to execute until both parallel branches are executed. Depending on the color of the token in the input place p_{11} , transition t_6 can select water supply preparation actions, which corresponds to the relationship shown in Fig. 3(c).

Assume that the diameter of the tanks is 30 m, and the distance between two neighboring tanks is 55 m (center to center). It is estimated that the time to failure (ttf) is about 11.3 min for the neighboring tanks when a tank catches fire. Suppose that automatic sprinkler equipment is damaged at the beginning of the accident, and that firemen must get to the fire site as soon as possible and take measures to prevent the domino effect (e.g. cooling neighboring tanks).

In a previous study, Peng [29] performed statistical analyses based on 44505 fire records from Japan and 14391 fire records from a China city and revealed that the emergency response times and the firefighting times follow log-normal distributions, although the log-normal distribution parameters of Japan data are different from those of China data. In this work, the log-normal distribution parameters (μ and σ) are roughly determined according to estimated mean duration values and taking into account appropriate variances of corresponding actions for the illustrative purpose.

According to the study of Peng [29] and NFPA’s report [14], the expected value of the duration of the action “discover the fire” is 4 min under the condition of an urban fire. In a tank farm, this duration can be shorter taking into account the presence of staff on site. Thus, a 1.5 min expected value of “discover the fire” is adopted in this work. In this example, teams from two fire brigades are dispatched to fight against the fire. The average duration of the action “arrive at the scene of the fire” of fire brigade 1 (e.g. the fire brigade of the plant) is shorter than that of fire brigade 2 (e.g. a fire brigade of the city). Hence, fire brigade 1 is considered to arrive at the scene with an average of 3.5 min, while fire

Table 6
Sampling value of transition durations (minute).

Transition	Duration	Transition	Duration
t_1	1.6	t_7	2.7
t_2	1.3	t_8	4.6
t_3	4.8	t_9	3.0
t_4	5.4	t_{10}	2.1
t_5	2.5	t_{11}	0
t_6	1.9	t_{12}	0

Table 7
Emergency response simulation process based on the sampling value.

Time	Marking	Executed/executing transitions
0	(1,1,0,0,0,3,3,0,1,0,0,0,0,0,0,0,0,0)	
1	(0,0,0,0,0,3,3,0,1,0,0,0,0,0,0,0,0,0)	t_1
2	(0,0,0,0,0,3,3,0,1,0,0,0,0,0,0,0,0,0)	t_1 t_2
3	(0,0,0,0,0,0,0,0,1,0,0,0,0,0,0,0,0,0)	t_2 t_3 t_4
4	(0,0,0,0,0,0,0,0,1,0,0,0,0,0,0,0,0,0)	t_3 t_4
5	(0,0,0,0,0,0,0,0,1,0,0,0,0,0,0,0,0,0)	t_3 t_4
6	(0,0,0,0,0,0,0,0,1,0,0,0,0,0,0,0,0,0)	t_3 t_4
7	(0,0,0,0,0,0,0,0,1,0,0,0,0,0,0,0,0,0)	t_3 t_4
8	(0,0,0,0,0,0,0,2,0,0,0,0,0,0,0,0,0,0)	t_3 t_4 t_5
9	(0,0,0,0,0,0,0,5,0,0,0,0,0,0,0,0,0,0)	t_4 t_5
10	(0,0,0,0,0,0,0,5,0,0,0,0,0,0,0,0,0,0)	t_5
11	(0,0,0,0,0,0,0,0,0,0,0,0,0,0,0,0,0,0)	t_5 t_6
12	(0,0,0,0,0,0,0,0,0,0,0,0,0,0,0,0,0,0)	t_6
13	(0,0,0,0,0,0,0,0,0,0,0,0,0,0,0,0,0,0)	t_6 t_8 t_9 t_{10}
14	(0,0,0,0,0,0,0,0,0,0,0,0,0,0,0,0,0,0)	t_8 t_9 t_{10}
15	(0,0,0,0,0,0,0,0,0,0,0,0,0,2,0,0,0,0)	t_8 t_9 t_{10}
16	(0,0,0,0,0,0,0,0,0,0,0,0,0,0,1,0,0,0,1)	t_8 t_9 t_{12}
17	(0,0,0,0,0,0,0,0,0,0,0,0,0,0,0,0,1,1)	t_8 t_{11}

brigade 2 will arrive at the scene with an average duration of 5 min which is the average time to arrive at the scene under the circumstance of urban fire emergency response. The average time of other actions is similarly determined or estimated. The mean values of the durations of the transitions are listed in Table 5.

Sampling the duration values of the emergency response actions (transitions in the TCPN model), the process of the emergency response can be simulated and analyzed. Table 6 shows a sample of the durations. Based on these duration data, the emergency response process is shown in Table 7, assuming that there are water supply facilities at the fire site, that is, $st = 1$. The marking in Table 7 indicates the state of the system at the end of the corresponding minutes. It is important to note that a transition removes tokens from its input places at the beginning of its execution and generates tokens in its output places at the end of the execution, which affects the value of the marking at the end of a given minute.

At the beginning, the marking of the Petri-net model is (1,1,0,0,0,3,3,0,1,0,0,0,0,0,0,0,0,0), which means that a tank is on fire and there are workers in the tank area (each of p_1 and p_2 has a token), three teams of fire brigade 1 and three teams of fire brigade 2 are on standby (each of p_6 and p_7 has three tokens), the fire state is unknown (p_9 has a token), and other places have no token.

Initially, transition t_1 is enabled and can execute. At the beginning of the execution of t_1 , tokens in places p_1 and p_2 are removed, and after 1.6 min the execution of t_1 ends, a token is put into place p_3 so that transition t_2 is enabled and can execute. At the end of the first minute, the marking of the Petri-net model has changed to (0,0,0,0,0,3,3,0,1,0,0,0,0,0,0,0,0,0). It should be noted that transition t_2 is still in execution at this time, the token in its input place has been removed, while the tokens have not been put into its output places. In this way, tokens “flow” from place to place and the model evolves forward to simulate the emergency response process. During this process, each token contains a time which is assigned by corresponding transition when the token is created.

If place p_{19} obtains a token, it means that cooling water has been

Table 8
Start time and end time of each action.

Action	Start time	End time	Action	Start time	End time
a_1	0	1.6	a_2	1.6	3.0
a_3	3.0	7.8	a_4	3.0	8.4
a_5	7.8	10.2	a_6	10.2	12.1
a_7	-	-	a_8	12.1	16.7
a_9	12.1	15.0	a_{10}	12.1	14.2
a_{11}	16.7	16.7	a_{12}	15.0	15.0

squirted out and neighboring tanks are under cooling. From the time-stamp of the token in place p_{19} , the duration from the occurrence of the fire to the cooling protection of neighboring tanks can be obtained. In this illustrative case, the neighboring tanks can be cooled in the 17th min (at 16.7 min).

Because the aim of this study is to analyze the time performance of an emergency process, the response time can be calculated to verify the model. Based on the data in Table 6, as well as the relationship between emergency actions, the start time and the end time of each action can be obtained, as shown in Table 8.

Comparing the start time and the end time of each action in Table 8 with those in the simulation process shown in Table 7, we can validate whether the model is running correctly. For example, the execution of a_5 starts at 7.8 min, and ends at 10.2 min, that is, starts in the 8th min and ends in the 11th min. This is consistent with the execution time of t_5 in Table 7. Of course, the duration of an action can also be accurately compared by extracting the time of tokens from input places and output places of a corresponding transition in the process of model simulation. The end time of action a_{11} is 16.7, which is the end of the studied process. This time shows that the duration between the occurring of the fire and the cooling of tanks is 16.7 min, which is consistent with the final time obtained through token “flowing” in TCPN model simulation, and indicates that the model is running correctly.

On the basis of the simulation of an emergency response process, the probability of preventing fire from escalating can be analyzed using Monte-Carlo simulation (MCS). Monte-Carlo simulation (MCS) is a numerical method based on random sampling or statistical simulation. The duration of an emergency response process is influenced by a number of random variables (duration of each emergency action). If the duration of each emergency action is sampled, then the duration of the emergency response can be obtained through the model. If a large number of such emergency response simulations are repeated, each random variable is sampled according to the probability distribution in each simulation, and the duration of the emergency process is determined accordingly, then the probability of the emergency response can be analyzed, such as the probability that its duration is less than the t_{ff} of the neighboring installation.

Although there were some studies on how to determine the sample size of MCS, there is no good rule to determine an accurate replication number of MCS [27,28,33]. In many studies using MCS, the number of replications is usually determined based on the researchers’ judgment of specific research problems. Generally, a large number of replications in MCS can better reveal the possible probabilities. In this work, the number is determined to be 10^4 , as it can reveal possible properties and the simulation time is not too long (about several seconds on a personal computer).

After 10^4 simulation trials of emergency response processes, the estimated success probability that the firemen arrive at the fire scene and cool the tanks in time is 17.3% (The average time from the beginning of the fire to the beginning of cooling tanks is about 14 min). If the fire site has no water supply facilities ($st = 2$), the corresponding success probability is 2.1%.

The cooperation between the emergency response actions will influence the efficiency of an emergency response. Using TCPN models, different cooperation modes can be analyzed and compared. In the

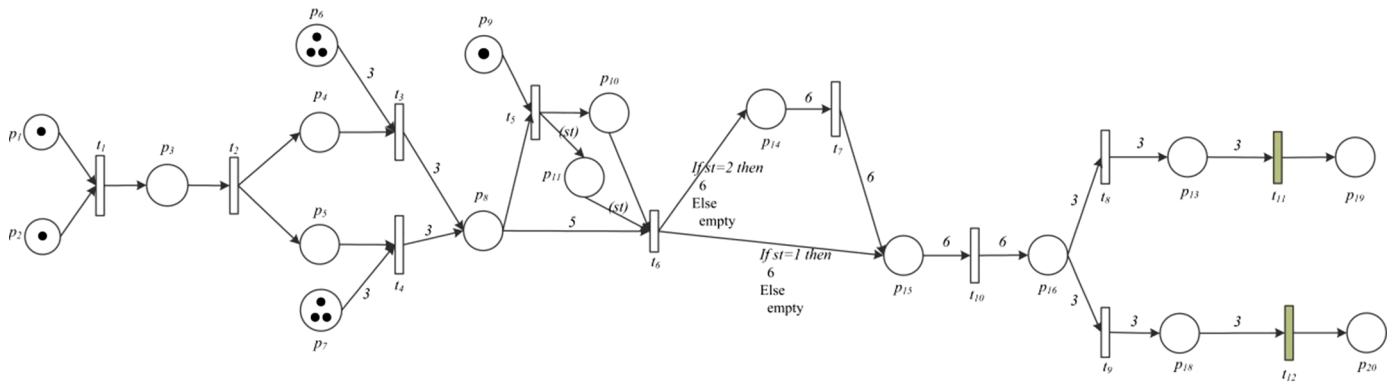

Fig. 8. TCPN model of the emergency response with a different cooperation mode.

model shown in Fig. 7, if the emergency teams firstly prepare cooling water and fire agents together with other teams, then prepare cooling facilities and firefighting facilities separately, the TCPN model can be changed as shown in Fig. 8. In this mode, the probability that the firemen get to the site and cool the tanks in time is about 6% when st is equal to 1 (the average emergency response time is about 15.5 min), and the probability of being in time is about 0.24% when st is equal to 2 (the average emergency response time is about 18.4 min).

It can be seen that different cooperation modes of emergency response actions may have great differences in the efficiency of emergency response. In an emergency response plan, emergency actions should be arranged, and this arrangement is difficult to analyze and evaluate in the usual way. In the preparation stage of the emergency response to an accident, different cooperation modes of emergency response actions can be simulated and analyzed using a Petri-net based modeling and simulation analysis approach. Therefore, a better emergency plan may be established by adjusting the relationship between actions to reduce the emergency response time. Similarly, this approach can also be used to analyze and improve the existing emergency plans.

The simulation process also shows that the suggested model can not only reflect the relationship between actions, but also simulate the emergency response process. Tokens “flow” from place to place and enable transitions to execute, helping to find out under what conditions an action can be performed and what results it will cause after it is performed. In addition, based on token times, the performance of a system can be analyzed. On the other hand, this example also reflects the drawback of the proposed approach, that is, flexibility is not very good. Changing the cooperation mode of emergency response actions requires corresponding modification of the TCPN model, such as from the model in Fig. 7 to the model in Fig. 8. Improving the self-adaptability of the model can also be a research goal in the future.

5. Conclusions

Emergency response is an important measure to reduce accident losses, and it should be part of the contents of a risk analysis. An emergency response process consists of a series of actions, and various emergency response actions cooperate together to achieve the goal of an emergency response. There are certain relationships between emergency response actions and thus impact on the success of the emergency response. In this work, aiming for the time analysis of emergency response, a timed colored Petri-net based approach is proposed to model the relationships between actions. Basic cooperation modes of emergency response actions and their time characteristics are analyzed. Time analysis problems can be solved by transferring time information through the “movement” of tokens in the TCPN model, which in turn can be used to analyze the performance of the model. Based on the time analysis of the emergency response, probability analysis can be performed, for instance, analyzing the probability that the duration of an

emergency response is less than a given time, e.g., the time of fire escalation.

An example of responding to a tank fire to prevent the fire from escalating illustrates the proposed approach. Multiple fire teams work together to fight against the fire. The TCPN model of this emergency response is established. A trial reveals per minute the evolution of an emergency response process with sampled durations of emergency response actions. On this basis, Monte-Carlo simulation analysis is performed to analyze probabilities of the emergency response process, and two cooperation modes are compared.

The Petri-net based time analysis is helpful for better revealing an emergency response process, and facilitating the arrangement of emergency response actions, for instance, comparing and selecting appropriate cooperation modes. Following the example, when firefighters arrive at the fire scene, which way is better: preparing the fire extinguishing agents and arranging the firefighting facilities sequentially, or preparing them in parallel? Another example can be given: for a fire related to production equipment, how to arrange the responding actions (such as alarming, reporting to the emergency department, shutting down equipment, evacuating personnel, saving property, and extinguishing fire) to the workers on the location? These questions can be solved using the proposed approach, and perhaps there are different optimal choices in different circumstances.

CRediT authorship contribution statement

Jianfeng Zhou: Conceptualization, Methodology, Writing – original draft. **Genserik Reniers:** Validation, Writing – review & editing.

Declaration of Competing Interest

We declare that we do not have any commercial or associative interest that represents a conflict of interest in connection with the work submitted.

Acknowledgments

This work is supported by National Natural Science Foundation of China (No. 71673060).

References

- [1] Abdolhamidzadeh B, Abbasi T, Rashtchian D, Abbasi SA. Domino effect in process-industry accidents-an inventory of past events and identification of some patterns. *J Loss Prev Process Ind* 2011;24:575–93.
- [2] Bernier C, Gidaris I, Balomenos GP, Padgett JE. Assessing the accessibility of petrochemical facilities during storm surge events. *Reliab Eng Syst Saf* 2019;188: 155–67.
- [3] Chahrour N, Nasr M, Tacnet JM, Bérenguer C. Deterioration modeling and maintenance assessment using physics-informed stochastic Petri nets: application to torrent protection structures. *Reliab Eng Syst Saf* 2021;210:107524.

- [4] Cheng Y, Zheng XP. Can cooperative behaviors promote evacuation efficiency? *Phys A Stat Mech Appl* 2018;492:2069–78.
- [5] Chun H, Wehrstedt KD, Vela I, Schönbucher A. Thermal radiation of di-tert-butyl peroxide pool fires-experimental investigation and CFD simulation. *J Hazard Mater* 2009;167:105–13.
- [6] Cozzani V, Gubinelli G, Antonioni G, et al. The assessment of risk caused by domino effect in quantitative area risk analysis. *J Hazard Mater* 2005;A127:14–30.
- [7] Darbra RM, Palacios A, Casal J. Domino effect in chemical accidents: main features and accident sequences. *J Hazard Mater* 2010;183:565–73.
- [8] David R, Alla H. Petri nets for modeling of dynamic systems – a survey. *Automatica* 1994;30:175–202.
- [9] Du L, Feng Y, Tang L, Lu W, Kang W. Time dynamics of emergency response network for hazardous chemical accidents: a case study in China. *J Clean Prod* 2020;248:119239.
- [10] Du Y, Sun J, Duan Q, Qi K, Xiao H, Liew KM. Optimal assignments of allocating and scheduling emergency resources to accidents in chemical industrial parks. *J Loss Prev Process Ind* 2020;65:104148.
- [11] Dulebenets MA, Abioye OF, Ozguven EE, Moses R, Boot WR, Sando T. Development of statistical models for improving efficiency of emergency evacuation in areas with vulnerable population. *Reliab Eng Syst Saf* 2019;182:233–49.
- [12] Elusakin T, Shafiee M. Reliability analysis of subsea blowout preventers with condition-based maintenance using stochastic Petri nets. *J Loss Prev Process Ind* 2020;63:104026.
- [13] Fay JA. Model of large pool fires. *J Hazard Mater* 2006;B136:219–32.
- [14] Flynn JD. Fire service performance measures. National Fire Protection Association; 2009.
- [15] Guo K, Zhang L. Adaptive multi-objective optimization for emergency evacuation at metro stations. *Reliab Eng Syst Saf* 2022;219:108210.
- [16] Ha S, Suh HW. A timed colored Petri nets modeling for dynamic workflow in product development process. *Comput Ind* 2008;59:193–209.
- [17] Hou J, Gai WM, Cheng WY, Deng YF. Statistical analysis of evacuation warning diffusion in major chemical accidents based on real evacuation cases. *Process Saf Environ Prot* 2020;138:90–8.
- [18] Jensen K, Kristensen LM. Colored petri nets: a graphical language for formal modeling and validation of concurrent systems. *Commun ACM* 2015;58:61–70.
- [19] Landucci G, Argenti F, Tugnoli A, Cozzani V. Quantitative assessment of safety barrier performance in the prevention of domino scenarios triggered by fire. *Reliab Eng Syst Saf* 2015;143:30–43.
- [20] Lee J, Mitici M. An integrated assessment of safety and efficiency of aircraft maintenance strategies using agent-based modelling and stochastic petri nets. *Reliab Eng Syst Saf* 2020;202:107052.
- [21] Li Q, Deng Y, Liu C, Zeng Q, Lu Y. Modeling and analysis of subway fire emergency response: an empirical study. *Saf Sci* 2016;84:171–80.
- [22] Li XY, Liu Y, Lin YH, Xiao LH, Zio E, Kang R. A generalized petri net-based modeling framework for service reliability evaluation and management of cloud data centers. *Reliab Eng Syst Saf* 2021;207:107381.
- [23] Liu C, Zeng Q, Duan H, Zhou M, Lu F, Cheng J. E-net modeling and analysis of emergency response processes constrained by resources and uncertain durations. *IEEE Trans Syst Man Cybern Syst* 2015;45:84–96.
- [24] MAHBulletin, 2017. Lessons learned bulletin No. 11, chemical accident prevention & preparedness, learning from emergency response – firefighter preparedness and protection. Available at: <https://www.kas-bmu.de/mahb-bulletin-lessons-learned.html>.
- [25] McGrattan KB, Baum HR, Hamins A. Thermal radiation from large pool fires. USA: National Institute of Standards and Technology; 2000.
- [26] Mudan KS. Thermal radiation hazards from hydrocarbon pool fires. *Prog Energy Combust Sci* 1984;10:59–80.
- [27] Mundform DJ, Schaffer J, Kim MJ, Shaw D, Thongteeraparp A, Supawan P. Number of replications required in Monte Carlo simulation studies: a synthesis of four studies. *J Mod Appl Stat Methods* 2011;10:19–28.
- [28] Muthén LK, Muthén B. How to use a monte carlo study to decide on sample size and determine power. *Struct Eq Model A Multidiscip J* 2002;9:599–620.
- [29] Peng C. The statistics law of fire response time and its correlation with the scale of urban fire (Thesis for master's degree). University of Science and Technology of China; 2010.
- [30] Peterson JL. Petri net theory and the modeling of systems. Lebanon, Indiana: Prentice Hall; 1981.
- [31] Reniers G, Cozzani V. Domino effects in the process industries: modelling, prevention and managing. Amsterdam, The Netherlands: Elsevier; 2013.
- [32] Reniers GLL, Dullaert W. DomPrevPlanning: user-friendly software for planning domino effects prevention. *Saf Sci* 2007;45:1060–81.
- [33] Schönbrodt FD, Perugini M. At what sample size do correlations stabilize? *J Res Personal* 2013;47:609–12.
- [34] Taleb-Berrouane M, Khan F, Amyotte P. Bayesian Stochastic petri nets (BSPN) - a new modelling tool for dynamic safety and reliability analysis. *Reliab Eng Syst Saf* 2020;193:106587.
- [35] Zhong M, Shi C, Fu T, Hea L, Shi J. Study in performance analysis of China urban emergency response system based on petri net. *Saf Sci* 2010;48:755–62.
- [36] Zhou J. Petri net modeling for the emergency response to chemical accidents. *J Loss Prev Process Ind* 2013;26:766–70.
- [37] Zhou J, Reniers G. Petri-net based simulation analysis for emergency response to multiple simultaneous large-scale fires. *J Loss Prev Process Ind* 2016;40:554–62.
- [38] Zhou J, Reniers G. Probabilistic Petri-net addition enabling decision making depending on situational change: the case of emergency response to fuel tank farm fire. *Reliab Eng Syst Saf* 2020;200:106880.
- [39] Zhou J, Tu C, Reniers G. Simulation analysis of fire truck scheduling strategies for fighting oil fires. *J Loss Prev Process Ind* 2020;67:104205.
- [40] Zuberek WM. Timed petri nets-definitions, properties and applications. *Microelectron Reliab* 1991;31:627–44.