

**A circular economy strategy for valorizing industrial saline wastewaters
Techno-economics and environmental impacts**

Roibás-Rozas, Alba; Saavedra del Oso, Mateo; Posada, John A.; Mosquera-Corral, Anuska; Hospido, Almudena

DOI

[10.1016/j.cej.2023.144819](https://doi.org/10.1016/j.cej.2023.144819)

Publication date

2023

Document Version

Final published version

Published in

Chemical Engineering Journal

Citation (APA)

Roibás-Rozas, A., Saavedra del Oso, M., Posada, J. A., Mosquera-Corral, A., & Hospido, A. (2023). A circular economy strategy for valorizing industrial saline wastewaters: Techno-economics and environmental impacts. *Chemical Engineering Journal*, 472, Article 144819. <https://doi.org/10.1016/j.cej.2023.144819>

Important note

To cite this publication, please use the final published version (if applicable). Please check the document version above.

Copyright

Other than for strictly personal use, it is not permitted to download, forward or distribute the text or part of it, without the consent of the author(s) and/or copyright holder(s), unless the work is under an open content license such as Creative Commons.

Takedown policy

Please contact us and provide details if you believe this document breaches copyrights. We will remove access to the work immediately and investigate your claim.



A circular economy strategy for valorizing industrial saline wastewaters: Techno-economics and environmental impacts

Alba Roibás-Rozas^{a,b,c,d,*}, Mateo Saavedra del Oso^{a,e}, John A. Posada^b, Anuska Mosquera-Corral^a, Almudena Hospido^a

^a CRETUS, Department of Chemical Engineering, Universidade de Santiago de Compostela, 15782 Santiago de Compostela, Spain

^b Department of Biotechnology, Faculty of Applied Sciences, Delft University of Technology (TU Delft), 2629 HZ Delft, the Netherlands

^c PRé Sustainability, Stationsplein 121, 3818 LE Amersfoort, the Netherlands

^d Olam Agri Conradstraat 38 D, 3013 AP Rotterdam, the Netherlands

^e Centre of Excellence for Packaging Sustainability (CEPS), Division of Packaging Materials, Stora Enso, 00180, Helsinki, Finland

ARTICLE INFO

Keywords:

Life cycle assessment, mixed microbial cultures
Polyhydroxyalkanoates
Salinity
Triacylglycerides
Wastewater treatment

ABSTRACT

Mussels cooking wastewater (MCW) and fish processing wastewater (FPW) were utilized as feedstocks for the production of polyhydroxyalkanoates (PHA) and triacylglycerides (TAG) at the laboratory scale. This study presents a comparison of the techno-economic and environmental performance of ten circular economy-based and innovative processes, in which PHA/TAG are produced using Mixed Microbial Cultures (MMC), with benchmark wastewater treatments for MCW and FPW. The innovative systems were modeled based on the upscaling of lab-scale data using mass balances, and a centralized downstream processing (DSP) plant was proposed for PHA/TAG extraction. This study is the first to conduct a techno-economic and environmental analysis of a system with a centralized DSP.

Consequently, the most favorable operational options were selected based on the techno-economic and environmental performance of the ten proposed scenarios. The techno-economic evaluations demonstrate that treatment costs for MCW and FPW could be reduced by 10% and 40%, respectively, compared to the benchmark treatment. Furthermore, environmental impacts could be significantly reduced (e.g., 10–70% for global warming potential) compared to the baseline scenario by implementing a system expansion approach.

Regarding the centralized DSP, the production cost of PHA from MCW falls within a competitive market threshold, ranging from 0.95 to 1.18 €/kg. However, the production costs of PHA and TAG from FPW (1.40–2.21 €/kg PHA and 0.51–0.69 €/kg TAG) are hindered by the lower biomass concentration achieved. Hence, this study demonstrates, for the first time, the potential feasibility of circular economy-based strategies for valorizing saline industrial wastewaters through a centralized DSP approach.

1. Introduction

Fish-canning industry effluents represent a challenging and outstanding opportunity for resource recovery into added-value

products such as volatile fatty acids (VFA), polyhydroxyalkanoates (PHA) and triacylglycerides (TAG) [1,2]. These products can be further utilized to obtain a wide range of high added-value products with multiple applications, including biofuels, chemicals, and packaging

Abbreviations: AD, annual depreciation; ADF, aerobic dynamic feeding; AGS, aerobic granular sludge; AP, acidification potential; CAS, conventional activated sludge; COD, Chemical Oxygen Demand; CSTR, continuous stirred tank reactor; C_{TAC} , total annual costs; C_{TCI} , total capital investment; DAF, dissolved air flotation; DSP, downstream processing; FBR, fed-batch reactor; F-EP, freshwater eutrophication potential; FPW, fish processing wastewater; FRS, fossil resource scarcity; GWP, global warming potential; GHG, greenhouse gas; HDPE, high density polyethylene; HRT, hydraulic retention time; HT, human carcinogenic toxicity; L, labor costs; LCA, life cycle assessment; LCC, life cycle costing; M, materials costs; m, maintenance costs; MCW, mussel cooking wastewater; ME, marine ecotoxicity; M-EP, marine eutrophication potential; MMC, mixed microbial cultures; NPCM, non-polymeric cell material; ODP, ozone depletion potential; PB, payback time; PHA, polyhydroxyalkanoates; SBR, Sequencing Batch Reactor; SDS, sodium dodecyl sulphate; TAG, triacylglycerides; U, utilities costs; VFA, volatile fatty acids; WWTP, wastewater treatment plant.

* Corresponding author at: CRETUS, Department of Chemical Engineering, Universidade de Santiago de Compostela, 15782 Santiago de Compostela, Spain.

E-mail address: alba.roibas-rozas@olamagri.com (A. Roibás-Rozas).

<https://doi.org/10.1016/j.cej.2023.144819>

Received 3 April 2023; Received in revised form 16 June 2023; Accepted 13 July 2023

Available online 17 July 2023

1385-8947/© 2023 The Authors. Published by Elsevier B.V. This is an open access article under the CC BY-NC license (<http://creativecommons.org/licenses/by-nc/4.0/>).

materials [3,4]. However, the implementation of these products in the market has been challenging.

Efforts have been made in solving major bottlenecks of the PHA value chain, i.e., fermentation and downstream processing. For example, a computer-aided design tool to assist decision-making, by enabling the screening of organic wastes as potential substrates for PHA production, was developed [5]. Additionally, an evaluation and optimization of PHA downstream processes were carried out to select the best available technologies [6]. Here, the TREASURE-TECHNOSALT¹ project developed and evaluated a modular treatment train to valorize and treat saline industrial effluents from the fish canning industry: mussel cooking wastewater (MCW) and fish processing wastewater (FPW). These effluents are addressed by TREASURE-TECHNOSALT because they are highly available and frequently produced in the Spanish North-Western region of Galicia. The treatment of these wastewater types presents operational challenges, such as high salinity concentrations, and high content of fat or nitrogen. As further explained in section 3.1, conventional treatments include conventional activated sludge reactors and dissolved air flotation units. These treatments are effective, but they are energy intensive and do not produce added value (i.e., they are not valorization techniques). Hence, different strategies were adopted to overcome those challenges.

Thus, the treatment and valorization of those effluents into PHA and TAG using mixed microbial cultures (MMC) were proposed as alternatives [7–10]. In this sense, Argiz et al. [7–9] investigated various feeding and operational strategies to maximize either PHA or TAG accumulation using FPW as feedstock, while Roibás-Rozas et al. [10] studied the simultaneous protein removal and PHA accumulation by adopting different process configurations using MCW as feedstock.²

Nevertheless, there is a scarcity of studies assessing the techno-economic and environmental feasibility of PHA/TAG from waste feedstocks using MMC. Furthermore, wider approaches rather than case-by-case solutions are needed, so these circular economy-based strategies can be further implemented. These strategies might include the centralization of downstream operations for resource optimization.

In this sense, previous works explored and validated the environmental feasibility of valorizing industrial wastewater into PHA, where environmental feasibility is defined by lower environmental impacts than the benchmark treatment (without valorization). Here, different (de)centralization options were suggested as a key for further viability [11]. For this reason, in this study, the option of a centralized extraction facility is evaluated for the first time for a system producing PHA/TAG.

Thus, several circular economy strategies are studied and compared to the current treatments for fish cannery wastewater to test its environmental and economic feasibility. In this sense, circular economy strategies are referred to as treatment approaches that involve waste valorization (transformation in value-added products such as PHA and TAG). Moreover, feasibility is defined as the lower cost/environmental impact of the circular economy-based treatments compared to the current treatments applied in fish cannery wastewater treatment plants (WWTPs).

Thus, the twofold objective of this research work is to *i*) select the best operation conditions to treat, while valorizing, saline industrial wastewaters (MCW and FPW) and *ii*) determine whether a centralized downstream processing facility to produce PHA and TAG would lead to economic and environmental feasibility. To achieve these objectives, scenarios based on different processing configurations are developed and upscaled from lab-scale data (described in section 2.3). Then, circular economy-based scenarios are assessed from a technoeconomic and environmental perspective to select the best strategies for wastewater management (section 4), while the centralized PHA/TAG downstream

processing facility is evaluated in section 5. Finally, results and future outlooks are discussed in section 6.

2. Methodology

First, lab-scale systems for PHA/TAG production were operated for long periods of time (more than one year per system) to gather data (see references [9,10,11]). These systems were operated with mixed microbial cultures (MMC) and they consisted of a system of several bioreactors operated with wastewater from fish canneries (MCW and FPW). The experimental data obtained, such as kinetic parameters, biomass concentration, and effluent quality were then used to upscale the bioreactors and the wastewater management systems using Excel spreadsheets. The mass balances are described in section 3 and further explained in sections S1 to S3 of the [Supplementary Material \(SM\)](#).

Industrial scale processes differ significantly from lab-scale and pilot-scale processes in terms of equipment, technologies used, and performance data. Thus, to assess the environmental and economic performance of emerging technologies, upscaling frameworks can be used to project industrial scale levels [12].

Next, lifecycle-thinking strategies were employed to evaluate the systems. Then, those circular economy-based scenarios that demonstrate better techno-economic and environmental performance (assessed in section 3.3) are selected for the evaluation of centralized PHA/TAG extraction. In section 5, the scenarios with the best performance are analyzed including downstream processing carried out in a centralized facility (see S4 in the SM). Two different approaches were considered: one where only PHA was recovered, and another where both PHA and TAG were recovered.

2.1. Environmental evaluation by life cycle assessment (LCA)

Environmental life cycle assessment (LCA) is a systematic and standardized methodology which determines the process' or product's environmental impacts throughout its life cycle. In this study, LCA was performed according to ISO 14004 and 14,040 [13]. In the following sections, it will be described the definition of the goal and scope, the functional unit and system boundaries (section 2.3), and the impact categories selected and the impact assessment methodology applied (section 2.1.1).

2.1.1. Background information and impact assessment

With regards to the background data, the ecoinvent 3.7.1 database was used [14]. The analysis of the environmental impacts followed a midpoint approach, with global warming potential (GWP), ozone depletion potential (ODP), acidification potential (AP), freshwater and marine eutrophication potential (F-EP and M-EP), marine ecotoxicity (ME), human carcinogenic toxicity (HT) and fossil resource scarcity (FRS) as the selected impact categories according to the latest reviewed LCAs on PHA production [15]. The impacts categories were assessed using the Hierarchist ReCiPe (H) v1.13 [16].

The assumptions made in the present study related to the LCA and the LCC are summarized below:

- Infrastructure is not included within the LCA system boundaries.
- The transport activities are not considered since previous studies for similar systems showed that their impacts are not significant for short distances, as these fish canneries are located at distances shorter than 10 km [11].
- High density polyethylene (HDPE) and biodiesel are assumed as the avoided products for PHA powder and TAG production, respectively, within the system expansion approach in the centralized biorefinery. Note that the selection of these avoided products is a methodological limitation of the study, which is discussed in section 6.1.

¹ <https://biogroup.usc.es/treasure>.

² The PHA obtained is a mixture of Polyhydroxybutyrate (PHB) and Polyhydroxyvalerate (PHV) with up to 25% PHV.

2.2. Economic evaluation by life cycle costing (LCC)

Life cycle costing (LCC) is an economic assessment method aligned with the environmental LCA in terms of system boundaries, functional unit, and methodological steps [17]. In general, costs can be divided into capital and operational costs. Regarding the former, the delivered equipment costs (C_{DE}) were estimated using correlations based on the characteristic size of each individual equipment [18] (see section S5 and S6 of the SM). Next, the total capital investment (C_{TCI}) was estimated by using the C_{DE} , applying a Lang Factor (Lf) of 5.03 (which is characteristic for a solids-fluids processing plant) and a Chemical Engineering Plant Cost index (CEPCI) of 607.5 for the year 2019³ (see Eq. (1)). The annual depreciation (AD) was calculated based on the C_{TCI} , with an interest rate (i) of 5% and a Project Lifetime (PT) of 20 years (see Eq. (2)). Concerning the latter, the total annual costs (C_{TAC}) were estimated using Eq. (3), which accounts for: utilities (U) and materials (m) costs. These costs were calculated based on the inventories of mass and energy flows (combined sections 3 and 4, S2-S5 of the SM) and literature [18]. Additionally, the maintenance costs (M) were assumed to be 3% of the C_{TCI} , and labor costs (L) were estimated as 10% of the C_{TAC} [18].

$$C_{TCI} = C_{DE} \cdot CEPCI \cdot Lf \quad (1)$$

$$AD = C_{TCI} \cdot [i(1+i)^{PT}] / [(1+i)^{PT} - 1] \quad (2)$$

$$C_{TAC} = AD + U + m + L + M \quad (3)$$

2.3. Goal & scope

The goal of this LCA and LCC is to assess the circular/innovative strategies for valorizing industrial saline effluents from both a techno-economic and environmental perspective. Since the function of the system is to treat (valorize) these effluents, the chosen **functional unit (FU) is 1 kg Chemical Oxygen Demand (COD) in wastewater** (for both the environmental and economic analyses). This is equivalent to 0.090 and 0.245 m³ of MCW and FPW, respectively (in refer to Table S2 and Table S3 in the SM for detailed wastewater characterization, which defines the FU and reference flows). Selecting this FU allows for the comparability of the two different systems. For instance, if 1 kg of PHA/TAG was chosen as FU, as done many times [15], the conventional systems cannot be compared. Accordingly, if 1 m³ of wastewater was chosen as FU, systems treating different types of wastewaters (such as MCW and FPW) will not be comparable due to their different organic load. Therefore, the mass of organic matter to be treated/valorized is the most suitable unit to represent the function of the evaluated systems. This choice applies to both environmental and economic assessments, representing impacts per kg COD treated and € per kg COD treated, respectively).

The first step of this study (section 3) involves defining the processes, systems, and scenarios to be assessed, from a circular economy perspective, in contrast to the traditional linear approach.

The second step (section 4) focuses on evaluating the up-scaled material and energy flows (obtained from the systems validated at lab-scale). This evaluation aims to compare their techno-economic and environmental performances with respect to the current (conventional/lineal) industrial treatments. In this second step (section 4), the system boundaries include the wastewater treatment and valorization sections (PHA/TAG-rich biomass production, but not PHA/TAG extraction). The goal of section 4 is to choose the systems with the best techno-economic and environmental performances. Then, the next step (step 3, section 5) aims to analyze the selected systems. In section 5, system boundaries include PHA/TAG extraction, and the PHA/TAG products are modelled

using system expansion (see section 2.3.1).

Note that, for the economic analysis, the cost is expressed as the wastewater treatment cost, which is represented by C_{TAC} (€/year, Eq. (3)) divided by the reference flow (kg of COD treated per year) in section 4 (thus, €/kg COD treated based on the chosen FU). However, in section 5, the cost of PHA/TAG production is also presented in €/kg of polymer to establish the polymer production cost. This is calculated by dividing the treatment costs (€/kg COD) by the system yield (kg PHA/TAG produced per kg COD treated).

2.3.1. Methodological choices for the assessment of a centralized DSP

The third step of this study (section 5) aims to determine whether a centralized PHA and TAG downstream processing facility could help to improve the techno-economic and environmental performance of the production systems. Note that the FU is still the mass of COD in the influent of the WWTP, allowing for the comparison of all scenarios. Furthermore, to study the economy of scale, different influent flows are considered (10, 20, and 50 times higher volumetrically). Thus, a scale ten times higher than the current one (x10) is considered, representing ten small facilities that collectively provide PHA/TAG-rich biomass to be extracted in a centralized facility. Accordingly, scenarios for twenty (x20) and fifty (x50) WWTPs are also assessed, with a centralized DSP facility of higher capacity. Results in this section are consistently expressed per FU (1 kg of COD) or per reference flow (kg COD treated per year). The selection of these production volume represents the number of existing canneries in this area of Spain. Currently, there are around 100 canneries [11], so 50 is considered the maximum number of facilities involved.

The system boundaries in Section 5 consider a **gate-to-gate** perspective, where the wastewater enters the system burden-free. While in Section 4 (where only wastewater treatment is considered), the system boundaries cover from the wastewater reception until the discharge of the effluents to the environment, in Section 5, the system boundaries also include the downstream operations for PHA/TAG. Thus, in section 5, the system boundaries include the WWTP modeling as in Section 3, in addition to the centralized DSP (i.e., PHA and TAG extraction and purification). Here, PHA and TAG products are modelled using a **system expansion** approach.

Therefore, the system boundaries encompass two sequential gate-to-gate systems: one for wastewater treatment, (i.e., waste valorization) and another for DSP operations (PHA/TAG extraction). This allows for expressing the cost/environmental impacts of the system as a whole (per FU – kg COD – or kg PHA) or as one of the sequential gate-to-gate subsystems (hence, the cost/environmental impacts of wastewater treatment and DSP can also be expressed individually).

Thus, the costs and impacts of wastewater treatment are allocated to the WWTPs, while the costs and impacts of PHA/TAG production (extraction) are attributed to the DSP facility. Therefore, the cost of PHA/TAG production is solely due to the extraction process.

Note that for environmental LCA, the burdens and benefits of bio-materials production (PHA/TAG extraction and PHA/TAG replacement of fossil products by system expansion) are allocated to the centralized facility where DSP is carried out (shaping, compounding, use and end-of-life phases of PHA/TAG are excluded from the system boundaries).

Finally, for the system where both PHA and TAG are produced, costs are assigned using **mass allocation**. Thus, the cost of the production of each compound is calculated based on the mass percentage of each product over total mass of bioproducts (TAG + PHA) extracted.

3. Systems and scenarios definition

The scheme of the scenarios assessed is depicted in Fig. 1, and the variables that change between scenarios are summarized in Table 1.

The production systems were categorized based on the type of saline industrial effluents treated, namely MCW or FPW. Additionally, the systems were classified according to the processing approach, whether

³ 2019 was chosen as the last year representing a stable economic situation, avoiding inflationary episodes and other non-representative economic trends.

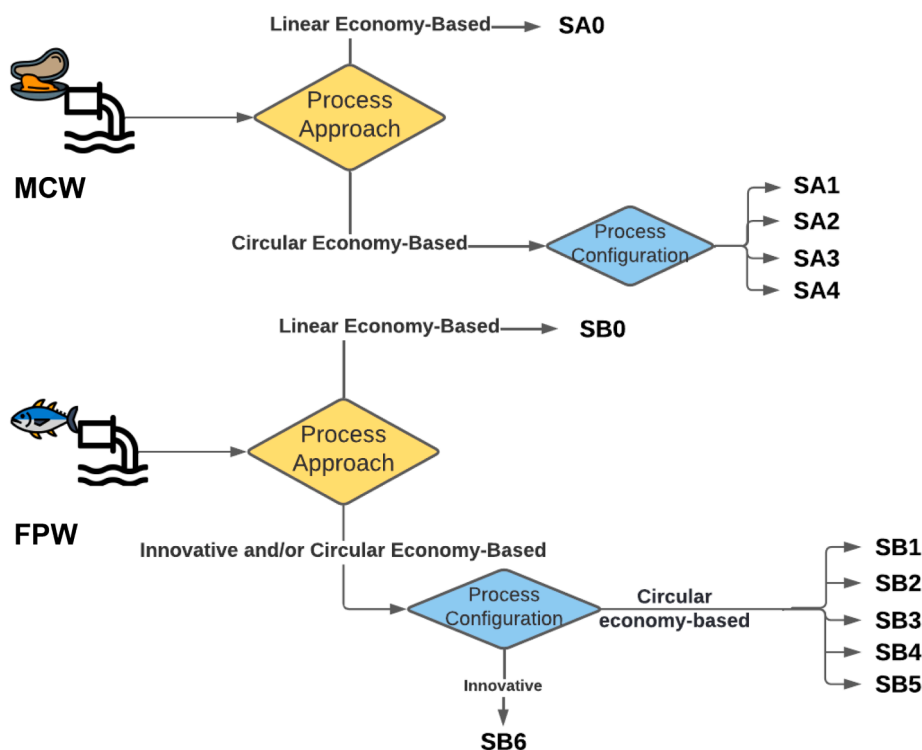

Fig. 1. Graphical representation of scenarios assessed under different approaches and process configurations. The mussel represents the MCW for System A (SA), and the tuna fish represents the FPW for system B (SB).

Table 1
Summary of scenarios, including main technical differences between systems.

Scenario	Approach	Enrichment type	Modification in the ADF	Other modified variables
SA0	Linear	Continuous	Does not apply	–
SA1	Circular	ADF	No.	Low pH in acidification
SA2	Circular	Modified ADF	Settling stage	Low pH in acidification
SA3	Circular	Modified ADF	Settling stage	Low pH in acidification and High Organic Loading Rate in the enrichment
SA4	Circular	ADF	No	High pH
SB0	Linear	Continuous	Does not apply	–
SB1	Circular	ADF	No	–
SB2	Circular	Modified ADF	Uncoupling C/N feeding	Dilution water addition along with the nitrogen in enrichment
SB3	Circular	Modified ADF	Uncoupling C/N feeding	Dilution water addition along with the carbon in enrichment
SB4	Circular	Modified ADF	Uncoupling C/N feeding	Low pH in enrichment
SB5	Circular	Modified ADF	Uncoupling C/N feeding	Neutral pH in enrichment
SB6	Innovative*	–	–	–

* The oil fraction is used for biodiesel production while the wastewater is treated using aerobic granular sludge.

linear or circular, and the specific process configurations. These configurations involved various aspects such as enrichment type, modifications in the aerobic dynamic feeding (ADF), and adjustments to cycles, including pH or feeding strategy.

€Detailed discharge limits and characterization of the industrial

effluents (MCW and FPW) can be found in Sections S1-S3 of the SM. The scenarios under study are categorized as System A (SA) and system B (SB), corresponding to MCW and FWP respectively. The index 0 refers to the linear approach, which represents the benchmark, while indexes 1–5 represent different circular approaches that have been initially tested at the lab-scale and subsequently scaled up for techno-economic and environmental evaluation.

In system SA, the wastewater is directly treated/valorized. In system SB, oil is first separated from water and then water and oil are treated in different process lines. However, SB6 in SB takes a different approach. Instead of the biological on-site valorization of oil into PHA/TAG as in SB1-SB5, the oil fraction of FPW is sent to an external facility for biodiesel production (as in the current scenario SB0). Meanwhile, the wastewater is still treated using aerobic granular sludge (AGS) as for SB1-SB5. Therefore, this scenario is considered innovative rather than circular due to the non-biological oil valorization.

3.1. Linear approaches

The linear approach represents the benchmark treatment for wastewater management in the fish canneries. These two scenarios (SA0 and SB0) were defined using publicly available data, samples taken on-site, and mass balances.

3.1.1. Mussel canning wastewater

SA0 represents the current linear treating for MCW (Fig. 2) and serves as the **baseline scenario**. It has an influent flow of 33,000 m³/year and an organic matter concentration of 11 kg COD/m³. This flow represents the average inlet of wastewater treated by the WWTP of the mussel cannery. The process design, flow, and plant configuration are based on information available in previous studies [11,19,20].

The treatment process begins with a primary settler that removes solids enhanced by the addition of iron (III) chloride. Then, there is a homogenization tank prior to a conventional activated sludge (CAS) unit. The CAS consists of one anoxic chamber and four aerobic

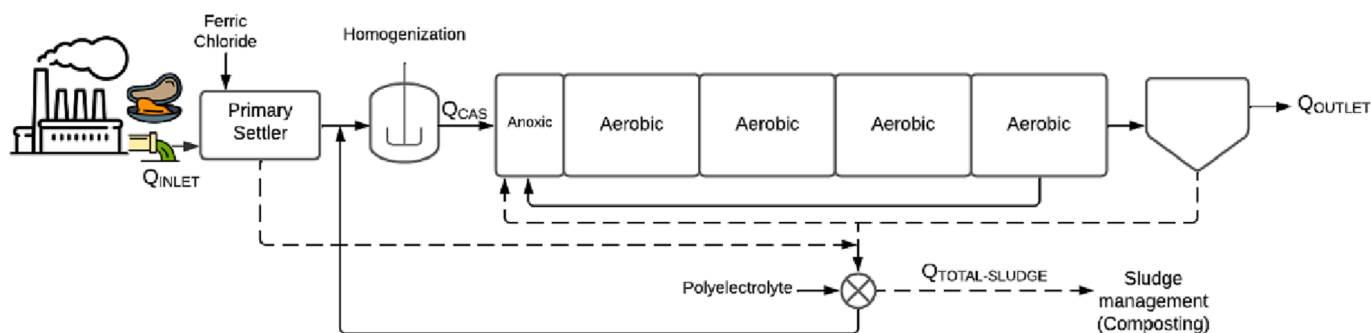

Fig. 2. Layout of the current linear treatment process of MCW. Dashed lines represent streams with high solids concentration and continuous lines represent liquid streams.

continuous series reactors, with a combined volume of 1,200 m³. The primary and secondary sludges are dehydrated in a centrifuge, and the resultant supernatant is returned to the homogenization tank. The dehydrated sludge is composted, which is the prevalent sludge management alternative for food industrial sludge in the region [11].

3.1.2. Fish processing wastewater

Fig. 3 illustrates the current linear treatment for FPW, which serves as the **baseline scenario (SB0)** for FPW. The process design is based on the public records of the local government [21]. It operates at a flow of 231,000 m³/year and with an organic matter concentration of 4 kg COD/m³. This flow represents the average wastewater inlet treated by the WWTP of the cannery.

The treatment starts at the dissolved air flotation (DAF) unit, which effectively removes approximately 95% of fats and 80% of solids present in the FPW. The remaining wastewater is treated in a 5,000 m³ CAS reactor divided into eight continuous series reactors, consisting of two anoxic and six aerobic chambers with internal recirculation. The sludge generated in the DAF unit is settled in 1 m³ tanks to remove naturally floating oils. The oil fraction is sent to an external facility where it is transformed into biodiesel. Afterwards, the remaining non-oil DAF sludge and the centrifuged CAS waste solids are sent to an external facility that centralizes sludge treatment by anaerobic digestion.

3.2. Circular/innovative approaches

This section provides an overview of the systems employed for the treatment and valorization of MCW and FPW within a circular economy framework. The design of these scenarios was developed based on extensive lab-scale operations, detailed information about which can be found in sections S2 and S3 of the SM, and in the literature [7,8,9,10].

Each system (SA with MCW and SB with FPW, represented by SA1 – SA4 and SB1 – SB6 scenarios) underwent continuous operation for over

year, using actual wastewater obtained from the fish canneries. During this operation, various stages were implemented under different operational conditions (see Table 1). This enabled the collection of kinetic and operational parameters such as biomass concentration, specific PHA production, and effluent quality. These parameters obtained experimentally are used for conducting the mass balances applied for the up-scaling.

To upscale the system from the lab-scale size to the required capacity for treating the wastewater flows from the canneries' WWTP (33,000 m³/year for MCW and 231,000 m³/year for FPW, see sections 3.1.1 and 3.1.2), mass balances were performed using Excel spreadsheets. This upscaling process was used to calculate the size of biological reactors and other process units of the WWTP (see the mass balances in sections S2.3 and S3.3 of the SM). The remaining plant equipment (i.e., pumps, centrifuges, reactors, stirrers, blowers, etc.) were designed according to the literature [18] (see the equations used for the design in section S5 the SM). The results of these mass balances are presented in sections 4.1 and 4.2, while sections 3.2.1 and 3.2.2 describe the systems based on innovative and circular approaches.

3.2.1. Mussel canning wastewater

The alternative four scenarios for MCW valorization under a circular approach (SA1 to SA4) were developed and scaled-up based on lab-scale results described in Roibás-Rozas et al. [10]. Systems SA1 to SA4 use a typical three-stage process for PHA production: 1) wastewater acidification in a continuous stirred tank reactor (CSTR), 2) MMC enrichment with ADF in a Sequencing Batch Reactor (SBR), and 3) biopolymer accumulation in a Fed-Batch Reactor (FBR) (Fig. 4).

The scenarios were defined depending on the ADF strategy for enriching the MMC SBR (see Table 1) and the pH and alkalinity conditions in the acidification CSTR. Subsequently, the remaining waste streams are treated in a CAS. The sludge streams from the CAS and CSTR are thickened in a centrifuge and treated externally by composting. Note

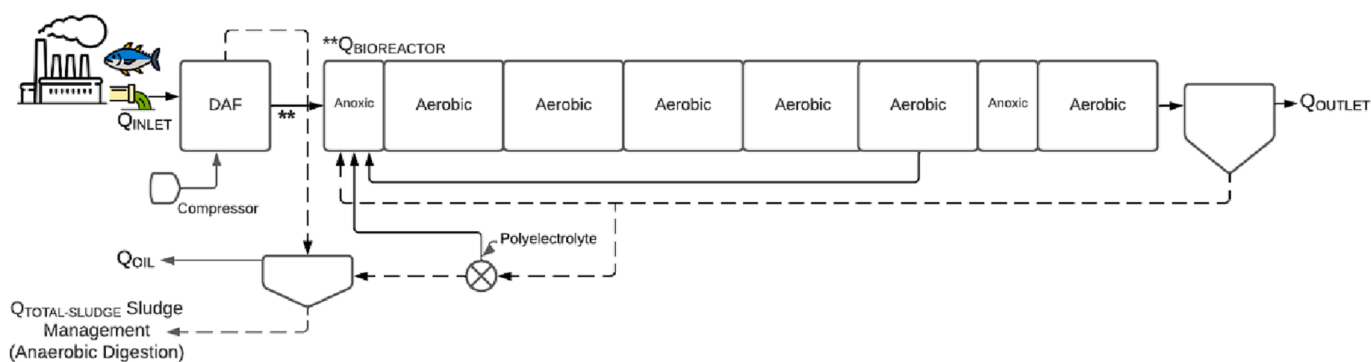

Fig. 3. Layout of the current linear treatment process of FPW. Dashed lines represent streams with high solids concentration and continuous lines represent liquid streams.

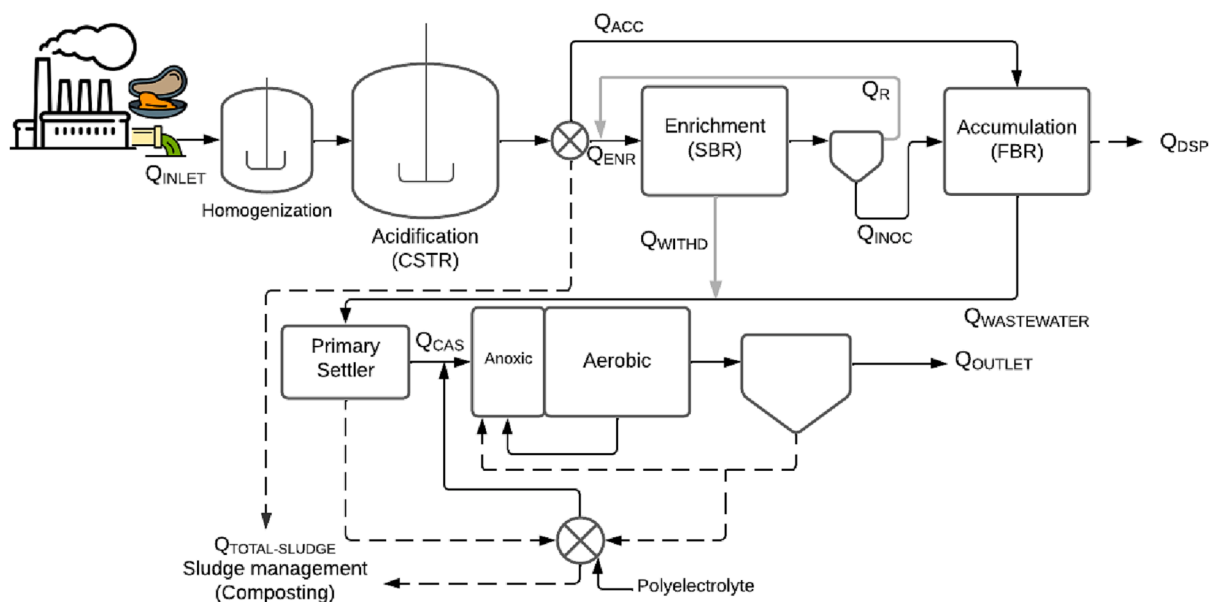

Fig. 4. Layout of the circular economy based WWTPs for MCW. The grey lines (Q_R and Q_{WITHD}) represent streams that may exist or not depending on the operational scenario (see S2 of the SM). Dashed lines represent streams with high solids concentration and continuous lines represent liquid streams.

that some streams are optional and may vary across different stages (indicated by grey lines in Fig. 4, representing recirculation and withdrawal streams non present in all stages). For detailed information on the individual process configurations, mass balances, reaction volumes, stream flows, and additional details for each scenario, refer to sections S2.2 and S2.3 of the SM.

3.2.2. Fish processing wastewater

The oil fraction of the FPW is separated in a DAF unit, as for SB0, and it is further valorized into PHA and TAG using an MMC (Fig. 5), as reported by Argiz et al. [9]. Hence, five process configurations (SB1 - SB5) have been considered, each characterized by different feeding strategies and pH conditions (see Table 1). Fats hydrolysis into long chain fatty

acids and MMC enrichment are carried out simultaneously in the enrichment SBR, while fats hydrolysis and biopolymer accumulation are carried out simultaneously in the accumulation FBR, avoiding the need for an acidification step. This is possible in this system since the long-chain fatty acids are hydrolyzed into shorter fatty acids [9]. Consequently, there is no requirement for VFA fermentation in this system, and as a result, the SB scenarios do not include an acidification unit.

The fat-free wastewater is treated in a sequencing batch reactor based on AGS. Solids washed out from the AGS are decanted in a settler without additional coagulants. Then, both AGS washout and DAF waste solids are concentrated in a decanter using chemicals, while supernatant is treated by the AGS. Finally, the thickened solids are externally treated by anaerobic digestion.

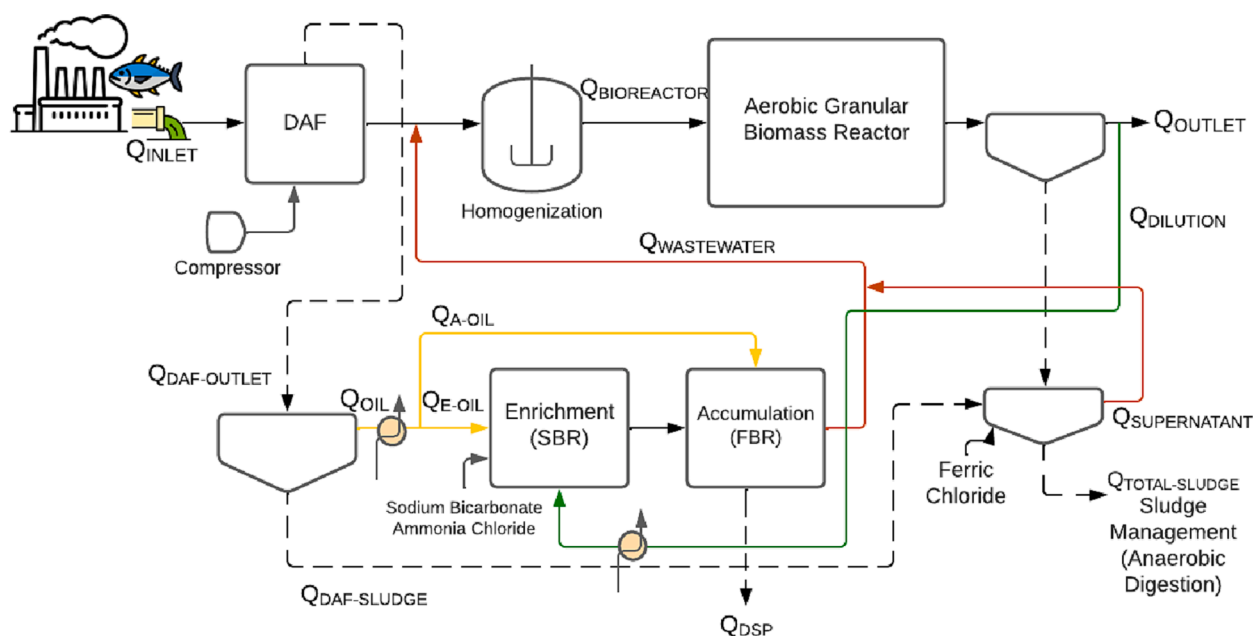

Fig. 5. Layout of the circular economy based WWTP for FPW. Color legend: waste streams returning to the main process line (the AGS feeding) are red, dilution water (recirculated from the outlet) is green, and oil streams are yellow. (For interpretation of the references to color in this figure legend, the reader is referred to the web version of this article.)

Fig. 5 represents the setup of the circular economy based FPW valorization process and labels the key stream flows required to perform the mass balances. More details about mass balances and process configuration can be found in Sections S3.2-S3.3 of the SM.

3.3. Centralized PHA downstream processing

For the three centralized downstream cases (PHA from MCW, PHA from FPW, and PHA + TAG from FPW), it was assumed that waste solids are managed by centralized anaerobic digestion. The DSP for PHA/TAG was modelled using Aspen HYSYS as indicated in Saavedra del Oso et al. [6].

3.3.1. PHA extraction

When only PHA is accumulated, the downstream processing technology used (Fig. 6) was chosen according to Saavedra del Oso et al. [6] where mechanical disruption was selected as the most competitive technology from both environmental and economic perspectives. For more information about process configuration, see section S4.1 in SM.

The process consists of a microfiltration membrane to concentrate the solids in the PHA-rich stream. Then, the solid-rich stream is acidified with sulfuric acid in a reactor followed by a high-pressure homogenizer and an alkaline reactor where sodium hydroxide and sodium dodecyl sulphate (SDS) are added to dissolve the non-polymeric cell material (NPCM). Another microfiltration membrane is used to both remove the solved NPCM and concentrate the PHA solid stream. Finally, the obtained powder is washed with water to remove impurities, and then a microfiltration membrane and a spray drier are used to obtain the purified PHA. All the permeates generated along the downstream processing (DSP) will be treated in a DAF unit.

3.3.2. PHA and TAG combined extraction

When both PHA and TAG are accumulated by the biomass, an alternative downstream process was designed which includes an extra section using a hexane/methanol mixture to recover the TAG based on Park et al. [22] and Saavedra del Oso et al. [6] (Fig. 6). For more information about process configuration, see section S4.2 in SM.

The main process difference with respect to the one in Fig. 6 is a higher temperature for the high-pressure homogenization (80 °C) and the fact that the permeate from the second membrane (after the mechanical disruption and the addition of SDS) is sent for TAG recovery. This stream is submitted to a hexane/ethanol extraction, and TAG is further recovered through a microfiltration membrane. Finally, hexane and ethanol are recovered in two distillation units.

4. Selection of best circular economy-based strategies for wastewater treatment

Once validated at lab scale, those process systems were up-scaled to perform a techno-economic evaluation and an environmental impacts analysis, and to compare them with the linear treatments currently applied in industry. The goal is to select the best treatment approach to analyze a biorefinery system with a centralized DSP in section 5. In

sections 4.1 and 4.2 the wastewater treatment systems for MCW and FPW are analyzed considering only the treatment systems (thus, PHA/TAG extraction is not included in the system boundaries at this level of the assessment).

4.1. Mussel cooking wastewater (MCW) treatment

The mass and energy balances for each scenario were performed according to lab-scale results [10]. The reactor volumes, stream flows, energy consumption, and the design of the different process units were also determined for each process configuration (Table 2, and section S2.3 and S5 in the SM).

The mass and energy flows (i.e., inventories) of the upscaled processes were used to calculate both the environmental impacts (due to energy/chemicals use and direct emissions) and process costs (due to

Table 2
Flows of the main streams, reactor volumes and energy use, of the System A scenarios using MCW.

	SA1	SA2	SA3	SA4	SA0
Stream flows (m ³ /day) ¹					
Q _{INLET}	100	100	100	100	100
Q _{ENR}	42.5	28.3	27.2	53.4	–
Q _{ACC}	55.9	70.3	71.1	43.4	–
Q _{INOC}	42.5	12.6	13.6	54.4	–
Q _{WITHD}	–	15.7	13.6	–	–
Q _{RE}	110.2	3.1	–	111.4	–
Q _{CAS}	86.9	90.7	87.6	87.9	127.2
Q _{DSP}	14.8	12.4	12.7	14.7	–
Q _{TOTAL-SLUDGE}	1.8	1.7	2.0	2.5	3.1
Q _{OUTLET}	83.4	85.9	85.3	82.8	96.9
PHA (kg/day) ²	26.0	45.3	176.9	34.2	–
Reactor volumes (m ³) ³					
V _{ENR}	152.7	31.4	27.2	165.8	–
V _{ACC}	49.2	41.5	42.3	48.9	–
V _{CAS}	92.4	199.7	115.8	147.0	1276.0
Energy consumption (kWh/day)					
Electricity Total	271.6	294.9	268.0	296.3	584.9
Pumps	4.1	4.6	3.4	4.3	0.4
Stirrers	178.3	201.2	177.5	192.5	35.0
Aeration	72.3	71.0	71.0	80.9	534.7
Centrifuges	16.8	18.0	16.2	18.6	14.9

¹ Q_{INLET} is the daily inflow, Q_{ENR} and Q_{ACC} are the feedings of the SBR and FBR, respectively. Q_{INOC} is the enriched biomass to the FBR from the SBR (in stages SA1, SA2, and SA4, it is the concentrated stream out of the settler after the SBR, in stage SA3 it is directly the SBR effluent). Q_{WITHD} is the withdrawal from the SBR for stages SA2 and SA3, and Q_R is the biomass-free SBR effluent used for feeding dilution in stages SA1, SA2, and SA4. Q_{DSP} contains the PHA-rich biomass to be extracted, Q_{CAS} is the wastewater flow to the conventional activated sludge (CAS) unit, and Q_{TOTAL-SLUDGE} is the stream with thickened solids wasted from the system. Q_{OUTLET} is the treated wastewater effluent to be discharged to the environment.

² PHA values refer to the biopolymer contained inside the biomass cells, as extraction is not performed in this step because the system boundaries stop at the WWTP gate.

³ V_{ENR}, V_{ACC} and V_{CAS} refer to the volumes of the enrichment (SBR), accumulation (FBR) and conventional activated sludge (CAS) reactors respectively.

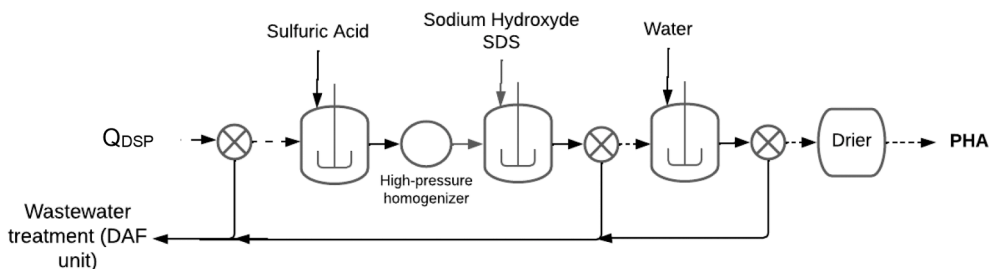

Fig. 6. Flowchart of the PHA downstream process. Dashed lines refer to streams with high solids concentration.

utilities and equipment cost as indicated in section 2.2 and S6 of the SM). The costs estimation summary is shown in Table 3 and Fig. 8.

4.1.1. Techno-economic analysis for SA

In the case of the conventional system SA0, the main direct cost (about 80%) is due to the CAS reactors and to indirect costs linked to electricity for aeration. For scenarios SA1 to SA4, the reactors account for around 40% of the direct costs, where the pumps and centrifuge oversee about 50% of the remaining expenses. Within the reactors cost, the CSTR has the biggest share for SA1-SA4 as it has a high volume (1000 m³) compared to the lower volume of the SBR and FBR (50 – 100 m³, Table 2). Accordingly, the stirrers of the acidogenic reactor consume more power than the aeration of the aerobic reactors. Regarding indirect costs, the main expenses are due to sludge management. In the case of SA4, higher waste management costs (especially in comparison to SA0 which produces the largest amount of sludge) are due to a higher solid concentration caused using chemicals in the process.

Thus, for conventional linear systems, the cost of the reactors together with aeration and sludge management are the main cost hot-spots. Circular economy-based approaches have lower aeration and sludge management costs due to the use of sequential reactors instead of continuous ones, but attention must be paid to pumps and centrifuges.

The cost of treating MCW under a linear economy approach (SA0) is 0.53 €/kg COD, while treating it using circular economy-based approaches would lead to costs in the range of 0.48 – 0.61 €/kg COD (Fig. 8). Note that, PHA production (extraction) is not included in the system boundaries yet. Therefore, the potential economic success of the circular economy-based process at this assessment level does not rely on the PHA value, but on the improved capacity of the systems proposed to treat the MCW more cost-efficiently.

Excluding scenario SA4 with higher operational costs due to more use of chemicals, the cost of treating wastewater under the circular economy-based approaches (SA1, SA2, and SA3) is in the range 0.49 ± 0.01 €/kg COD. The scenario with the lowest cost is SA3, with 0.48 €/kg COD.

4.1.2. Environmental analysis for SA

In order to select the best design scenario, the environmental impacts assessment was performed considering eight impact categories as described in Section 2.3. The results of the circular economy-based approaches are shown in Fig. 9 with respect to the scenario with the largest impacts SA4. Hence, SA4 is the worst option due to the use of chemicals for pH control in the acidification CSTR, which coincides with the highest cost.

The greenhouse gas (GHG) emissions of the scenarios are in the range of 0.21–0.60 kg CO₂-eq/kg COD treated, as shown in Fig. 10. The full characterized results are shown in the Supplementary Table of the SM.

The main driver for the impacts in the studied categories is the use of electricity and the treatment of sludge by composting (see the

Table 3

Equipment purchase cost and main utilities costs for the scenarios SA0 – SA4 with MCW (for a 33,000 m³/year of wastewater, so 100 m³/day and 330 workdays/year).

	SA1	SA2	SA3	SA4	SA0
Equipment Purchase Cost (k€)	269.7	269.7	243.9	281.8	254.2
All reactors	109.9	106.9	101.3	115.7	193.0
(CSTR alone)	(72.8)	(72.8)	(72.8)	(72.8)	–
Pumping	90.6	92.8	73.9	96.4	22.6
Stirrers	19.3	20.7	19.2	20.5	6.0
Blowers	2.6	2.6	2.6	2.6	13.1
Centrifuge	46.8	46.8	46.8	46.8	19.5
Main Utilities' Costs (k€/year)	41.1	39.2	43.0	53.5	59.6
Electricity	10.8	11.7	10.6	11.7	23.2
Sludge management	30.4	27.5	32.4	41.8	36.4
C_{TOT} (M€)	1.39	1.39	1.26	1.45	1.29

contribution analysis in section S7 of the SM). In fact, an electricity use considerably lower for SA1 - SA4 than for the linear economy scenario SA0 causes the generally lower environmental impacts of the circular economy-based scenarios with respect to benchmark SA0. However, when the use of chemicals increases (SA4), this becomes the most relevant driver for most categories. Moreover, sludge management by composting generates noticeable impacts in GWP, ODP and AP for all scenarios (see section S7 in SM).

4.1.3. Selection of the best scenario for SA

Scenario SA3 is selected as the best option for further analysis in section 6 due to lower costs (Fig. 8) and lower climate change impacts than the benchmark scenario (Fig. 10), and higher PHA accumulation (Table 2).

4.2. Fish processing wastewater treatment

The mass and energy balances for each scenario were performed according to lab-scale results [9]. The reactor volumes, stream flows, energy consumption, and the design of the different process units were also determined for each process configuration (Table 4, and section S3.3 and S5 in the SM).

The mass and energy flows (i.e., inventories) of the upscaled processes were used to calculate both the environmental impacts (due to energy/chemicals use and direct emissions) and process costs (due to utilities and equipment cost as indicated in section 2.2 and S6 of the SM). The costs estimation summary is shown in Table 5 and Fig. 11.

4.2.1. Techno-economic analysis for SB

The reactors with an innovative/circular approach (SB1-SB6) have smaller volumes than the one used under the conventional approach SB0 (Table 4). This is due to the shorter residence times linked to the operation of the innovative AGS reactors (HRT = 10 h) compared to the CAS ones for this industrial wastewater treatment (HRT = 7.1 days). However, scenarios SB1-SB5 have more process units and pumps. Hence, even when there is no CSTR unit in the circular SB scenarios (SB1-SB6), as the oil is hydrolyzed in the SBR and FBR [9], there is an AGS unit that also has significant aeration requirements.

In fact, the AGS process has higher oxygen needs per unit of volume of reactor than the CAS process. However, the CAS reactor has a volume of 5,000 m³ while the AGS has a volume of approximately 360 m³. Consequently, Table 5, which summarizes the costs estimation, shows that the operating costs of the AGS unit are still lower than those of the CAS unit. In fact, the circular/innovative scenarios (SB1-SB6) have in general lower total management costs than the current linear one (SB0) (see Table 5 and Fig. 10).

On the other hand, SB0 and SB6 present operational costs higher than the circular economy-based scenarios (Table 5). Nevertheless, for SB6, indirect costs are approximately the same as for circular scenarios SB1-SB5, since the cost of waste management (including oil treatment) is very high, while the electricity needs are lower, and no heat is used. However, in the case of the conventional scenario SB0, both the costs of oil and waste sludge treatment, as well as the energy demand due to aeration requirements in the biological reactor, are higher compared to SB1-SB6.

The circular economy-based scenarios considered are more economically attractive than the current treatment process (Fig. 11). However, the cost of on-site oil valorization is still higher compared to the external treatment for biodiesel production, as implemented in SB6. In fact, the cost of the biological valorization of oil into PHA/TAG is around 1,100 €/m³, while the current cost for oil management is around 500 €/m³ [23] (which is, approximately, 0.48 €/kg COD_{OIL} for biological valorization versus 0.22 €/kg COD_{OIL} for biodiesel).

Treating FPW with the existing technology costs 0.52 €/kg COD (SB0), while treating it by the alternative scenarios would result in a cost of 0.30 – 0.33 €/kg COD for SB1-SB5. Moreover, cost is as low as 0.21

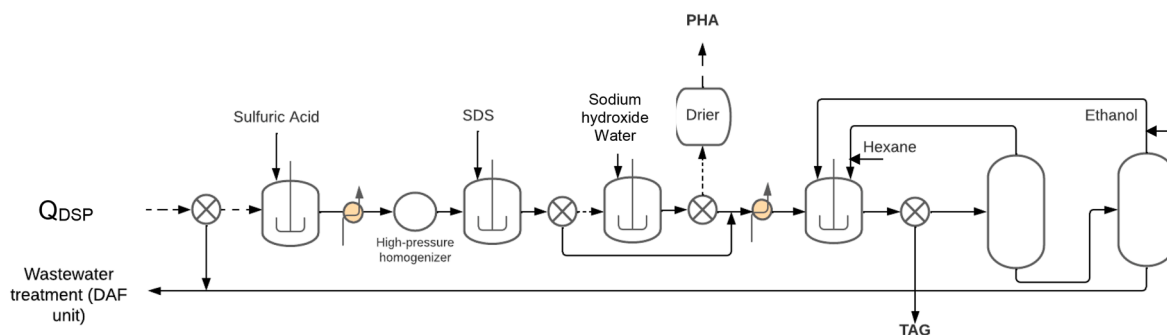

Fig. 7. Flowchart of the PHA and TAG downstream processing. Dashed lines refer to streams with high solids concentration.

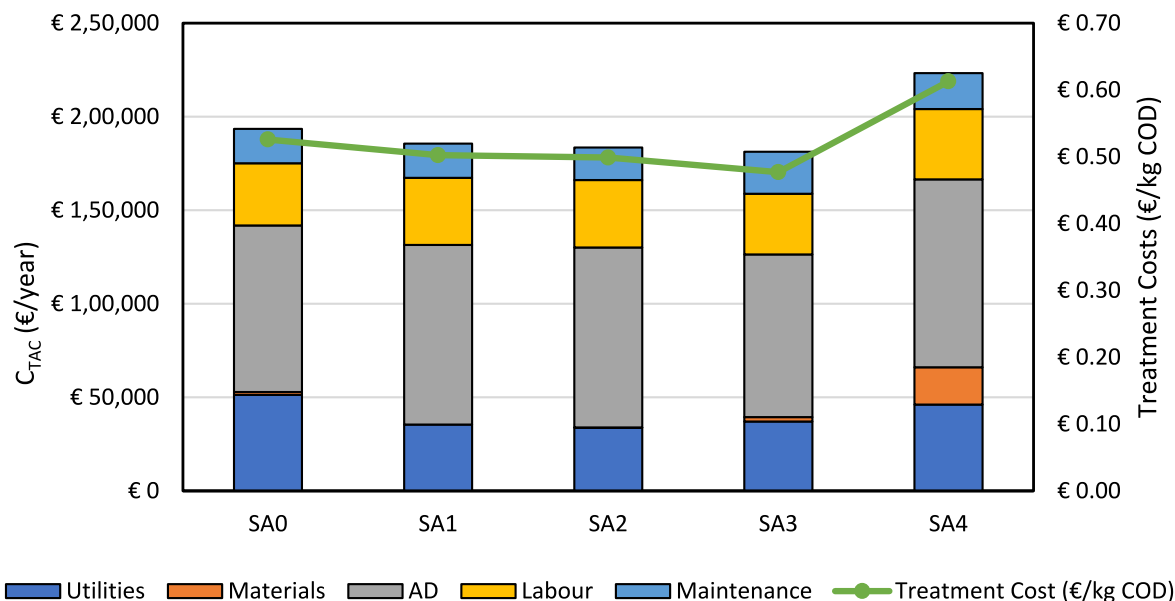

Fig. 8. Total annual costs (for a processing capacity of 33,000 m³/year) and treatment costs per unit of treated influent (1000 kg of COD with an organic matter concentration of 11 kg COD/m³) of the System A scenarios with MCW.

€/kg COD (**SB6**) using AGS without valorizing the oily fraction into PHA/TAG (Fig. 10). Here, SB6 has higher costs due to sludge management, but the higher cost linked to the heat and electricity requirements of the biological valorization of the oil, and higher direct costs for SB1-SB5 with respect to SB6 hinders the economic feasibility of TAG production in the circular/innovative approaches with respect to biodiesel production (Table 5).

4.2.2. Environmental analysis for SB

Regarding the environmental impacts, the alternative processes have lower impacts than the current one for all categories except for M-EP (see Fig. 12 and the contribution analysis of each scenario in section S7 in the SM) due to minor differences in the quality of the effluent, even though all processes comply with the discharge limits. Only **SB1** performs slightly worse in some categories because of the higher use of chemicals for the enrichment of the MMC, as explained in section 4.1, dosages were not optimized during this stage. The GHG emissions of the **SB** scenarios are 0.57–0.20 kg CO₂-eq/kg COD treated, as shown in Fig. 13 (the full characterized results are shown in the Supplementary Table of the SM).

The main drivers behind the impacts for the **SB** cases are the use of electricity and the treatment of biowaste (see Fig. 13 and section S7 of SM). The use of chemicals (ammonium chloride and sodium bicarbonate) is also relevant for some scenarios like **SB1**, as the enrichment process in the valorization system had uncoupled nitrogen and carbon

feedings and pH control.

Moreover, as the operation of the valorization reactors for **SB** needs to happen at a mild temperature range to avoid oil solidification, the use of heat has non-negligible impacts for this system. So, the steam consumption results in additional environmental impacts (10 – 20% of GWP, AP and ME, see Fig. 13 and section S7.2 and the Supplementary Table of the supplementary material). Finally, the use of anaerobic digestion for sludge management results in environmental credits (specially for ODP, ME and HT, but also for GWP) as it generates biogas.

Finally, managing oil externally by esterification for biodiesel production (**SB6**) results in the best environmental profile of all the studied scenarios. Therefore, replacing the current CAS by a system based on biofilms and AGS would lead to lower use of electricity, heat, and chemicals, so the process would have a better profile both economically and environmentally.

4.2.3. Selection of the best scenario for SB

Results indicate that the application of innovative treatments (like the use of AGS) yield in lower costs and environmental impacts. However, biological valorization of oil into PHA/TAG is not yet the most attractive option compared to an option where AGS is used to treat wastewater, but oil is valorized into biodiesel (**SB6**).

Based on the results above presented and discussed, the chosen scenarios for further analysis into the downstream process are **SB2** and **SB3** for PHA + TAG and PHA recovery, respectively. Additionally, **SB6**

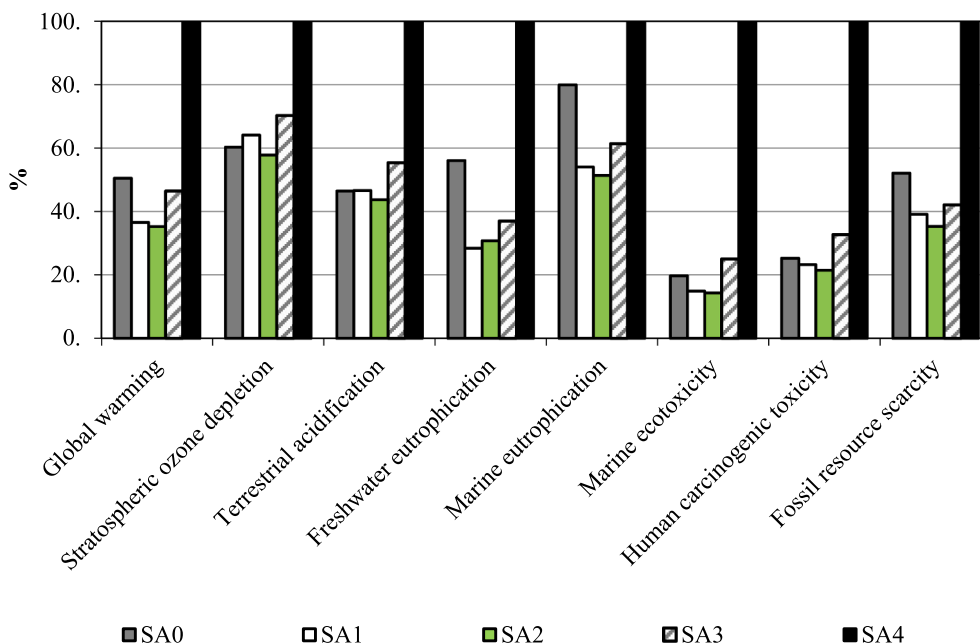

Fig. 9. Environmental impact results of the SA cases for MCW treatment with respect to the scenario with the highest impacts SA4 (PHA downstream processing is not included at this level of the assessment, since it is included in section 5 with the centralized DSP).

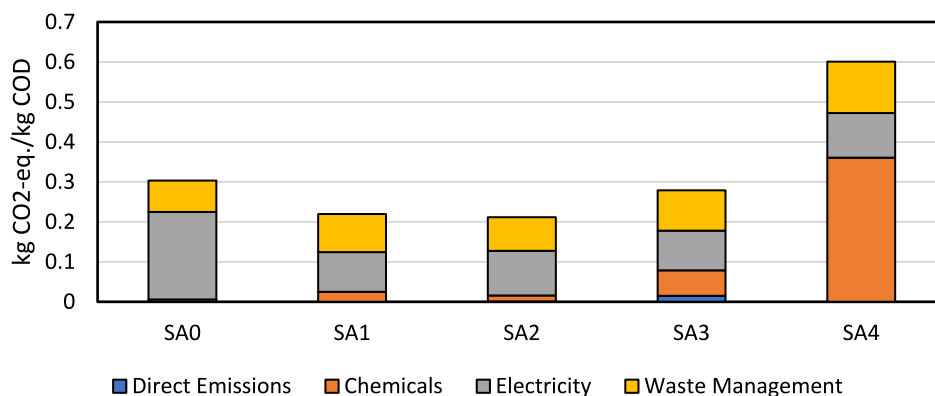

Fig. 10. Total annual costs (for a processing capacity of 231,000 m³/year) and treatment costs per FU (1000 kg of COD) of the System B scenarios with FPW.

is also considered as an innovative process without biomaterial recovery.

5. Analysis of a centralized downstream processing

Results of section 4 showed that, in most process configurations, the circular-economy and/or innovative approaches have the potential to improve the economic performance compared to the current conventional approach. The analysis also showed that process configuration affects both the environmental and the economic performance. Therefore, the best alternative for each system was selected for the assessment of the PHA and TAG downstream processing in a centralized facility.

In the case of MCW (SA), the process configuration SA3 was selected to upscale the facilities, as: i) it has the lowest costs at small scale, ii) lower environmental impacts are expected if waste sludge is treated by anaerobic digestion instead of composting, and chemicals addition is optimized, and iii) it is the scenario with the highest net PHA accumulation.

For the case of FPW (SB), two alternatives based on two DSP approaches are considered, as two products can be generated (PHA and TAG). For exclusive PHA production, the considered process configuration is SB3, as it has the highest production of PHA. For extraction of

PHA + TAG combined, SB2 was considered, as it is the only process approach that presented non-negligible concentrations of both products simultaneously. Furthermore, SB6 is considered for further assessment of its DSP's environmental performance since it presented the best economic performance in the first stage of the study. Note that it is not necessary to perform an economic evaluation of SB6 in the second stage of this study, as no biomaterials are produced in this scenario. Therefore, the cost of wastewater treatment was already assessed in the first stage of the evaluation, where no DSP costs/biomaterial production benefits were included. Here, the cost of PHA/TAG production is only allocated to the extraction process, assuming that the PHA/TAG-rich biomass arrive burden-free to the centralized facility (the burdens of biomass production are allocated to the WWTP).

5.1. Economic assessment

As previously presented, the cost of wastewater management was 0.48 €/kg COD for SA3 (with MCW, Fig. 8) and 0.30–0.33 €/kg COD for SB2 and SB3 (with FPW, Fig. 11). Fig. 14 shows the cost of producing PHA/TAG in a centralized biorefinery, where the costs of wastewater treatment (thus, PHA/TAG-rich sludge production/biomass generation) are allocated to the WWTPs, and PHA/TAG extraction, to the centralized

Table 4

Flows of the main streams, reactor volumes and energy use, of the System B scenarios using FPW.

	SB1	SB2	SB3	SB4	SB5	SB6	SB0
Stream flows (m ³ /day) ¹							
Q _{INLET}	700	700	700	700	700	700	700
Q _{OIL}	0.53	0.53	0.53	0.53	0.53	0.53	0.53
Q _{E-OIL}	0.20	0.20	0.24	0.20	0.20	–	–
Q _{A-OIL}	0.32	0.32	0.29	0.32	0.32	–	–
Q _{DILUTION}	202.0	202.0	238.6	202.0	202.0	–	–
Q _{BIOREACTOR}	867.1	867.1	896.8	867.1	867.1	867.1	742.2
Q _{TOTAL-SLUDGE}	3.1	3.1	3.2	3.1	3.1	3.1	4.3
Q _{DSP}	40.4	40.4	47.8	40.4	40.4	–	–
Q _{OUTLET}	656.5	656.5	649.1	656.5	656.5	656.5	694.6
PHA (kg/day)	2.3	55.6	68.8	11.4	43.7	–	–
TAG (kg/day)	11.9	20.2	3.8	57.0	7.3	–	–
Reactor volumes (m ³) ²							
V _{ENR}	202.2	202.2	238.9	202.2	202.2	–	–
V _{ACC}	101.1	101.1	119.5	101.1	101.1	–	–
V _{BIOREACTOR}	361.3	361.3	373.7	361.3	361.3	361.3	5000
Energy consumed (kWh/day)							
Electricity	593.0	593.0	632.4	593.0	593.0	510.3	2561.2
Total							
Pumps	6.6	6.6	8.2	6.6	6.6	4.9	3.2
Stirrers	34.7	34.7	35.9	34.7	34.7	34.7	300.0
Aeration	324.3	324.3	360.9	324.3	324.3	243.3	2019.6
Centrifuge	–	–	–	–	–	–	11.0
DAF	227.4	227.4	227.4	227.4	227.4	227.4	227.4

¹Q_{INLET} is the daily effluent flow. Q_{OIL}, Q_{E-OIL}, Q_{A-OIL}, Q_{DILUTION}, are, respectively: the total flow of oil, the oil fed to the SBR and to the FBR, and the flow of wastewater effluent bypassed to the SBR as growth media for the MMC. Q_{BIOREACTOR} is the flow to the AGS reactor (SB1-SB5) or to the CAS unit (SB0). Q_{TOTAL-SLUDGE} is the stream with thickened solids to be externally managed.

²V_{ENR}, V_{ACC} and V_{BIOREACTOR} refer to the volumes of the enrichment (SBR), accumulation (FBR), and conventional activated sludge (CAS) reactors respectively.

³PHA/TAG refers to the amount of bioproduct contained inside the biomass cells. Thus, to the intracellular form of the products.

facility. Thus, two sequential gate-to-gate systems are represented (see section 2.3.1.1). Table 6 shows these costs linked to the yearly flows and production scale.

For the three systems, the utilities and the annual depreciation are the main contributors to the cost of the product (Fig. 14). The centralized downstream costs for PHA and TAG production decrease when the process scale increases accordingly with the economy of scale. For example, for a centralized downstream system supplied by 20 facilities of SA3, the processing costs are 1.05 €/kg PHA, while for a system supplied by 50 facilities of SA3 with centralized DSP, the respective

Table 5

Equipment purchase cost and main utilities costs for the scenarios with FPW (for a 231,000 m³/year of wastewater, so 700 m³/day and 330 workdays/year).

	SB1	SB2	SB3	SB4	SB5	SB6	SB0
Equipment Purchase Cost (k€)	321.7	321.7	340.2	321.8	321.7	149.9	458.5
Reactors,	80.1	80.1	87.2	80.1	80.1	33.1	309.9
(of which AGS)	(23.0)	(23.0)	(23.6)	(23.0)	(23.0)	(23.0)	–
Pumping	72.4	72.4	73.3	72.4	72.4	33.4	21.6
Stirrers	4.2	4.2	4.2	4.2	4.2	4.2	10.7
Blowers	7.2	7.2	7.2	7.2	7.2	3.8	40.9
Compressor	75.4	75.4	75.4	75.4	75.4	75.4	75.4
Heat Exchanger	82.5	82.5	93.0	82.5	82.5	–	–
Main Utilities' Costs (k€ /year)	96.3	107.4	121.6	107.4	107.4	122.0	259.0
Electricity	23.5	23.5	25.0	23.5	23.5	18.1	101.4
Heat	55.6	66.7	78.8	66.7	66.7	–	–
Sludge management ²	17.2	17.2	17.8	17.2	17.2	103.9	157.6
C _{TCl} (M€)	1.67	1.67	1.77	1.67	1.67	0.78	2.33

¹ The compressor is used in the DAF, and the heat exchangers are used to ensure that the biological valorization system maintains a temperature of 22.5 °C to ensure oil's emulsion.

² For SB1-SB5, the cost of sludge management includes the price of managing waste solids, but not oil (oil is valorized in the SBR and FBR system). For SB6 and SB0, the costs estimation includes the price of oil treatment by biodiesel production.

costs are 0.95 €/kg PHA (Fig. 13).

Considering that the market value of HDPE has fluctuated between 0.70 and 1.04 €/kg in the last four years (2018–2022) [24], the production cost of PHA from MCW at the x20 and x50 scales would be competitive.

For FPW (SB3), the cost of the centralized extraction is 2.16 €/kg PHA, and it decreases as scale increases, resulting in 1.84 €/kg PHA and 1.56 €/kg PHA for the scales x20 and x50, respectively (Fig. 14). Here, prices are close to the competitive cost of HDPE for the highest scale, although they are still about 30% higher.

If the overall cost of PHA production was considered (including the cost of wastewater treatment and DSP), it would result in 3.95 – 4.18 €/kg PHA for SA3 with MCW, in 17.9 – 18.5 €/kg PHA for SB3 with FPW, and 15.2 – 15.6 €/kg PHA and 47.7 – 48.8 €/kg TAG for SB2 with FPW (note that the process yields are 0.019 kg PHA/kg COD and 0.007 kg TAG/kg COD for SB2, 0.024 kg PHA/kg COD for SB3, and 0.16 kg PHA/kg COD for SA3 according to the lab-scale data).

The reason for these significant differences is the feedstock. For SB, only the oil fraction of the water is separated and treated to produce PHA in a system with a low biomass concentration [9,10]. On the other hand, for SA, the entire wastewater stream is directly used for PHA production. Thus, when accounting also for the treatment of wastewater, and considering the low TAG/PAG productivity, the production cost for SB is very high.

Additionally, the extraction of TAG, requires the inclusion of distillation columns that utilize hexane and methanol at 80 °C in the extraction process (Fig. 7). This increases the direct and utilities costs. However, as two products are generated, the cost allocation by mass results in competitive prices for both products when only the DSP is accounted for. Although both processes are not in mature technology readiness levels, assuming a general market price of 1€/kg for both products, PHA would have a competitive market price for SB3, and TAG for SB2. However, the production of PHA under the SB2 and SB3 approaches would not yield in competitive prices.

5.2. Environmental assessment

The environmental impact results of the cases selected in Section 4 (i. e., SA3, SB2, SB3, and SB6) are shown in Fig. 15, and they are also compared with the baseline scenarios (SA0 and SB0).

It is worth noticing that results of the environmental impact assessments are presented for the combined processes of wastewater treatment and PHA/TAG extraction (i.e., waste valorization plus DSP). This is in contrast to the results of the economic evaluation, which considered two sequential gate-to-gate system boundaries.

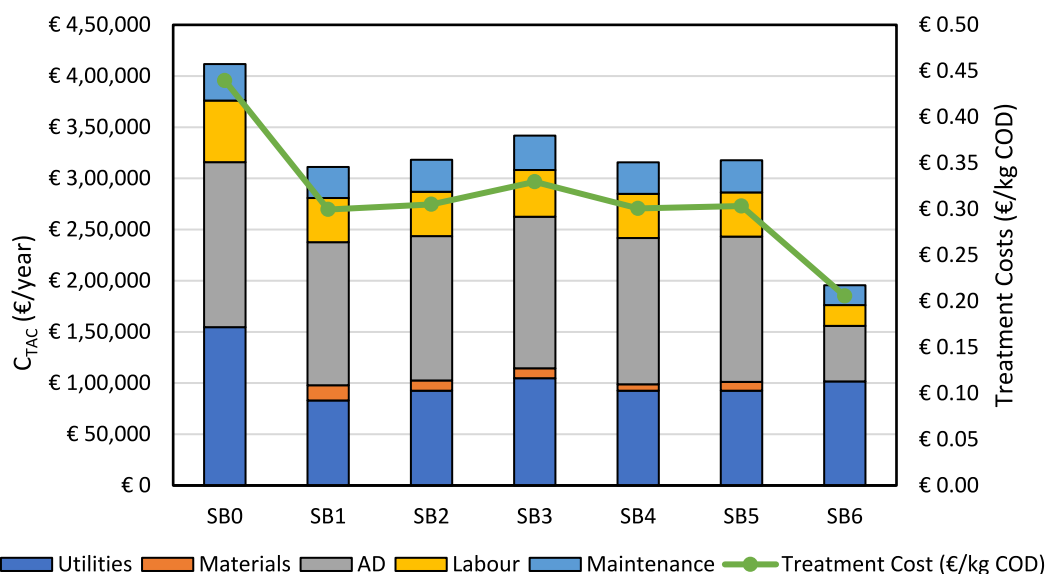

Fig. 11. Environmental impact results of the SB cases for FPW treatment with respect to the scenario with the highest impacts (PHA downstream processing is not included at this level).

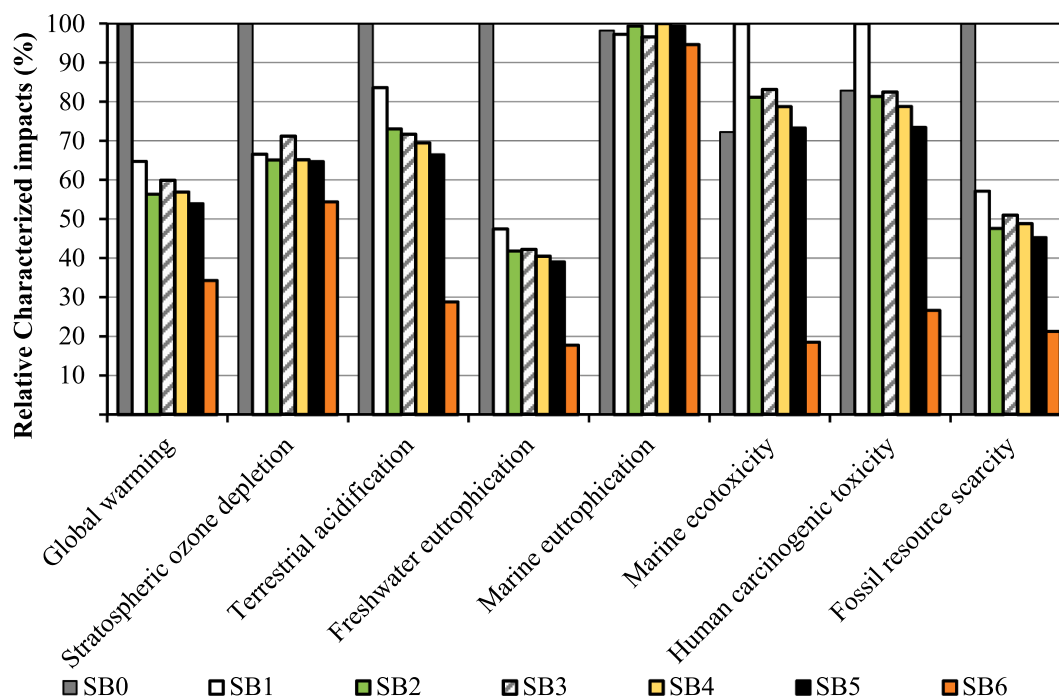

Fig. 12. Characterized results of the SB cases for FPW treatment for the category of climate change (PHA downstream processing is not included at this level of assessment).

Additionally, the results shown in Fig. 14 and Fig. 15 are applicable to the x10, x20 and x50 scenarios, as the environmental performance is characterized with respect to the FU (as also shown in the Supplementary Table of the SM). The circular economy-based process (SA3) with MCW outperforms the linear economy-based process (SA0) for all categories except ODP, primarily due to the use of chemicals in the DSP. Positive effects are especially noticeable for GWP (Fig. 15) and FRS, due to the environmental credits generated by the application of the system expansion approach (thus, the avoidance of HDPE production).

Likewise, the conventional process (SB0) with FPW exhibits higher impacts compared to SB3 in all categories except M-EP, due to minor variations in the effluent quality and flow between scenarios (Table 4),

while SB2 performs worse than SB0 for some categories due to the lower bioproduct yield. Finally, scenario SB6 demonstrates low impacts as it does not involve the biological valorization of oil. Instead, oil is treated through biodiesel production, avoiding the use of electricity and heat in the DSP.

As the amount of bioproduct generated for systems using FPW is low (SB2 and SB3, see Table 4), the potential benefits of avoiding petrochemical materials are not enough to counterbalance the burdens of operating the train of biological reactors, as it was the case for SA3. On the other hand, biomass production is lower for oil-based systems than for MCW ones (0.019 kg PHA/kg COD for SB2 (with 0.007 kg TAG/kg COD), 0.024 kg PHA/kg COD for SB3, and 0.16 kg PHA/kg COD for SA3

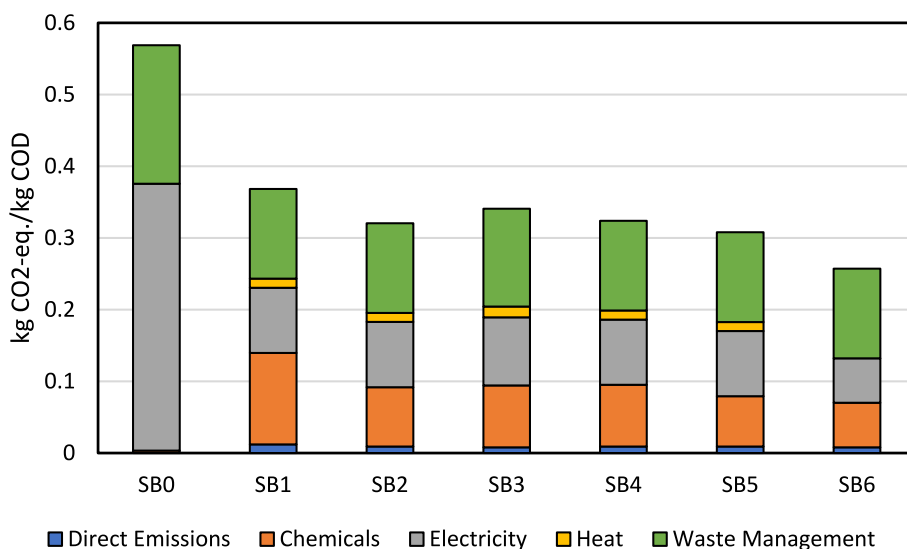

Fig. 13. Downstream Cost of PHA and TAG production from MCW and FPW for a centralized approach (since the PHA/TAG rich biomass comes burden-free to the facility, the biomaterial production costs are only linked to the downstream operation). The different production factors x10, x20 and x50 are upscaled with respect to the baseline scenario for one facility with a capacity of 100 m³/day for MCW and 700 m³/day for FPW).

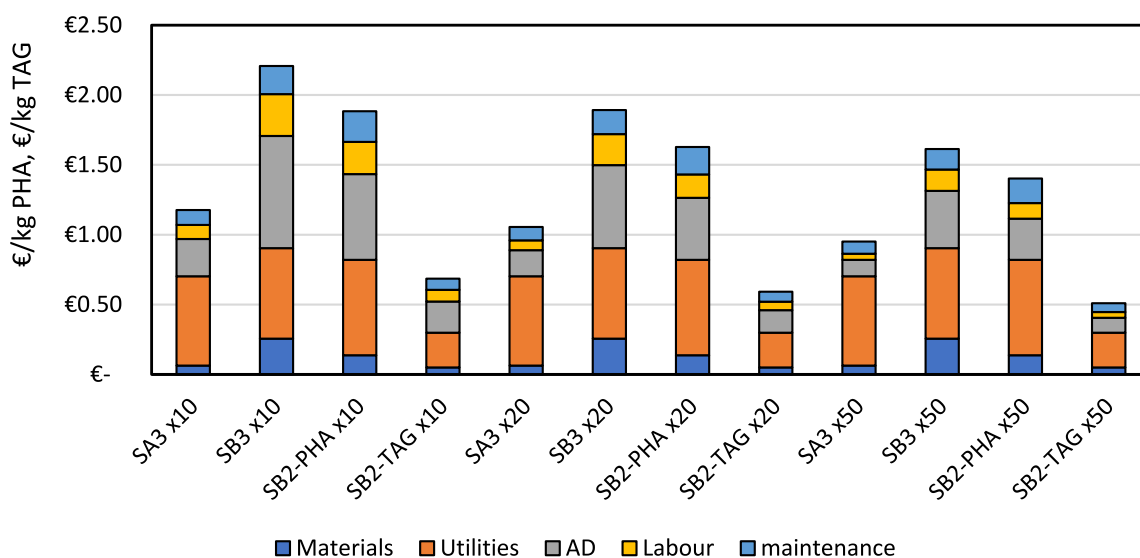

Fig. 14. Environmental impact results of the selected scenarios for centralized DSP of MCW and FPW treatment/valorization with a gate-to-gate perspective (system boundaries consider both wastewater treatment and PHA/TAG extraction; bioproducts are modelled by system expansion) for a functional unit of 1 kg COD. Results are valid for the three centralized scales, ×10, ×20 and ×50.

Table 6

Cost of biomaterial production (considering only DSP cost in a centralized facility) and yearly flows linked to the production.

System	DSP Cost (€/kg PHA)	PHA production (t PHA/year)	Wastewater Flow (m ³ /year)	Organic Matter (t COD/year)
SA3 (MCW)	1.18 – 0.95	584 – 2,919	330,000 – 1,650,000	3,630 – 18,150
SB3 (FPW)	2.21 – 1.61	237 – 1,135	2,310,000 – 11,550,000	570 – 2,888
SB2 (FPW)	1.88 – 1.40	183 – 917	2,310,000 – 11,550,000	577 – 2,888
	0.69 – 0.51 €/kg TAG	67 – 334 t TAG/year		

[9,10]). This makes the performance of **SB2** worse than that of **SB3**, and for some categories (like ecotoxicity or ozone depletion), also worse than **SB0**. Therefore, the margin for improvement (i.e., impacts reduction) of the circular economy-based systems with oil feedstock is narrower than that for **SA** scenarios, where the impact reduction potential is clearer.

6. Discussion

The current study demonstrates that circular economy-based strategies to manage industrial effluents may outcompete linear economy-based approaches from both economic and environmental perspectives. Furthermore, these circular approaches provide raw materials that can be further processed into added value products such as PHA and

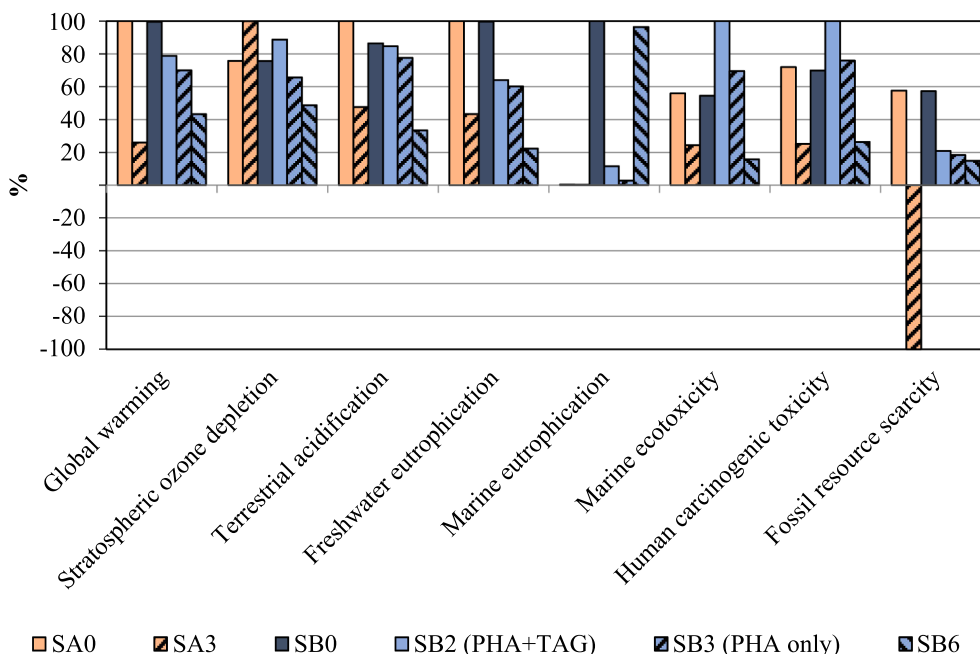

Fig. 15. Environmental impact results of climate change for the selected scenarios for centralized DSP of MCW and FPW treatment/valorization with a gate-to-gate perspective (system boundaries consider both wastewater treatment and PHA/TAG extraction; bioproducts are modelled by system expansion) for a functional unit of 1 kg COD. Results are valid for the three centralized scales, $\times 10$, $\times 20$ and $\times 50$.

TAG. In order to make these circular economy-based strategies happen, economy of scale and distance for transportation play key roles in regions such as Galicia (NW Spain), where around 70 companies generate about 85% of the total Spanish canned fish products and 50% of the total European canned tuna production [25]. Here, a system where these existing small- and medium-capacity WWTPs can act as biomass providers for a centralized downstream facility (as considered in section 5), has shown to have the potential to improve both economic and environmental benefits.

6.1. Techno-economic feasibility

To the best of the authors' knowledge, a few studies have provided insights on the techno-economic of MMC-based PHA and/or TAG producing systems [6,26–30]. Even more, for TAG production, the information available for comparative analysis is scarce. Therefore, this section is focused purely on the discussion around PHA production.

Fernández-Dacosta et al. [26] achieved 1.40 – 1.95 €/kg PHA for a production plant of 1500 t PHA/year depending on the DSP method, while Bengtsson et al. [27] used for the first-time pilot scale data to estimate 3.40 €/kg PHA for a production capacity of 5000 t PHA/year.

Crutchik et al. [28] also assessed the effect of scale using data from actual WWTPs, where production costs were estimated at 2.26 €/kg PHA for a 90 t PHA/year and 1.26 €/kg PHA for a 5700 t PHA/year. Pérez et al. [29,30] discussed the geographical dependence of the economic feasibility for PHA production, and costs estimation ranged 1.5 – 6.9 €/kg PHA when part of the methane was used to generate energy on-site for systems using methanotrophic MMC.

With focus only on PHA downstream processes, Saavedra del Oso et al. [6] identified mechanical disruption as the most cost competitive technology (0.2 €/kg PHA).

Under the approach applied in this study, all the costs of PHA-rich biomass production are allocated to the waste management, as the system function is to comply with the discharge limits. Thus, the PHA production cost would only correspond to those of the extraction process in a centralized DSP facility, being 1.18, 1.05, and 0.95 €/kg PHA for production scales of about 580, 1200, and 3000 t PHA/year, respectively, for wastewater feedstock (MCW). For waste oil feedstock (FPW),

the PHA extraction costs are 2.16, 1.84, and 1.56 €/kg PHA for production scales of about 230, 450, and 1100 t PHA/year (if TAG is not recovered), and 1.88, 1.863, and 1.40 €/kg PHA for production scales of 183, 366, and 917 t PHA/year (when TAG is recovered for scales of 67, 134, and 334 ton TAG/year).

These results outperform most of the literature or at least are in the same range. Despite the current study uses the same DSP technology as Saavedra del Oso et al. [6], there are significant differences regarding the costs. They are caused by the differences in the scale, biomass concentration, and PHA content (10,000 t PHA/year, 11 kg solids/m³, and 68% PHA weight, respectively), compared to the ones in the present work (183 – 1,135 t PHA/year, about 4 kg solids/m³, and around 40% PHA weight).

6.2. Environmental feasibility

Regarding the environmental performance, among the about 60 research works assessing the impacts of PHA production recently revised, only 11 considered MMC-based processes. GWP was the most studied impact category [16]. Although results vary depending on different methodological or process choices, GWP-related emissions of DSP ranged from 0.5 to 5.0 kg CO₂-eq/kg PHA for previous studies [31]. Furthermore, in the case of TAG, this current study is the first one to evaluate the environmental performance of TAG production from wastewater.

In general terms, the results showed that the emissions linked to the wastewater treatment decreased due to the lower use of energy compared to the conventional treatments currently applied, making the processes beneficial from a wastewater management perspective.

The emissions of the extraction process (excluding wastewater treatment) are 0.39 kg CO₂-eq/kg PHA for the system using MCW, 0.49 kg CO₂-eq/kg PHA for the system using FPW without TAG extraction, and 1.9 kg CO₂-eq/kg PHA and 5.13 kg CO₂-eq/kg TAG for the oil system that also recovers TAG. These values fall in the low emission range compared to other literature studies (see the characterized results in section S8 and in the Supplementary Table in the SM).

Regarding the whole system (i.e., accounting for wastewater treatment and PHA/TAG extraction, see Fig. 15), CO₂ emissions are 0.50 kg

CO₂-eq/kg COD treated for **SA0** and 0.13 kg CO₂-eq/kg COD treated for **SA3** in the MCW systems. For the FPW systems, GWP emissions are 0.49 kg CO₂-eq/kg COD treated for **SB0**, 0.38 kg CO₂-eq/kg COD treated for **SB2**, 0.33 kg CO₂-eq/kg COD treated for **SB3** and 0.21 kg CO₂-eq/kg COD treated for **SB6** (see the SM for detailed impacts results). Under this approach (an analysis showing the impacts of wastewater treatment plus centralized DSP with the bioproducts modelled under system expansion), DSP effects are around 0.05 kg CO₂-eq/kg of COD treated in the WWTP influent. Here, most of the impacts are linked to the operation of the ten small WWTP, and not to the operation of the centralized DSP facility using low-cost extraction processes.

It is not possible to compare all the scenarios by expressing them per kg of PHA, as linear economy-based scenarios do not produce any biomaterial. Nevertheless, for circular economy-based scenarios, emissions are 0.39 kg CO₂-eq/kg PHA for **SA3**, 20.0 kg CO₂-eq/kg PHA for **SB2** (with 55.18 kg CO₂-eq/kg TAG), and 14.5 kg CO₂-eq/kg PHA for **SB3**.

As mentioned above, for the processes using oil as a feedstock to produce biomaterials (oil from FPW), the process efficiency and product yield are significantly lower than those using non-oil wastewater (MCW) due to the lower concentration of biomass generated in the system [9,10]. Hence, the emissions of CO₂ per kg of biomaterial produced for **SB2** and **SB3** are significantly higher than for the system using wastewater (**SA3**). Considering that the GWP emissions of HDPE production are around 0.75 kg CO₂-eq/kg, only the production of polymers under **SA3** (i.e., from mussels' wastewater) seems to be competitive from an environmental point of view.

Finally, the discussion also includes the system expansion approach, which considers diesel and HDPE as avoided products for TAG and PHA, respectively. Although the modelling of TAG as avoided production of diesel is uncertain, previous studies addressed the use of a petrochemical polymer as an avoided product to model PHA produced with MCW [11]. In those studies, different replacement ratios (mass of petrochemical polymer avoided by mass of biopolymer introduced in the market) and different petrochemical polymers (such as PET) were assessed. In the mentioned work, different sensitivity analysis were conducted using MCW as a feedstock. The conclusion is that even with more conservative approaches or when considering other polymers like PET, the environmental feasibility of the circular economy-based system (i.e., lower environmental impact than the benchmark scenario) is still maintained.

6.3. Limitations of the study and future outlook

Taking a gate-to-gate approach, this study has excluded potentially relevant geographical aspects, such as biomass transport from the WWTP gate(s) to the DSP gate. Moreover, up-scaling was done based on lab-scale data, as no pilot-scale information was available for the processes.

In this regard, the ECOPLYVER⁴ project will operate and optimize the pilot-scale production of PHA and TAG from similar saline industrial effluents. Besides, the project will determine the structural composition and properties of the different products. Consequential LCA seems to be the most appropriate framework for assisting in the development of present and future bio-based products [32–34]. Saavedra del Oso et al. [35] have shed light on how waste-to-PHA biorefineries could evolve in the future and where the attention of stakeholders should focus on. Concretely, extraction yield and PHA content in biomass were pointed out as the key parameters for the environmental performance.

Another aspect for future consideration within goal & scope definition, is the assumption that HDPE and biodiesel are the avoided products since they are not fully equivalent to PHA and TAG. Both products require further processing to have the same functions as HDPE and biodiesel. Although previous works have addressed this issue and concluded that environmental feasibility is maintained, further

investigation is needed to confirm the limits of this conclusion.

7. Conclusions

Although the use of MMC and waste streams to produce value-added materials is a promising solution for resource recovery processes, there is a lack of prospective environmental and economic studies. The present research work used three-year laboratory data to up-scale several systems for industrial effluents' treatment and biomaterials (PHA and TAG) production to carry out both detailed techno-economic and environmental assessments.

Results showed that costs of wastewater treatment can potentially be reduced when treating these effluents under a circular economy approach using sequential reactors to produce PHA/TAG-rich biomass. This can also lead to 10–70% lower environmental impacts, depending on the operational strategy chosen and the use of chemicals.

Moreover, the present study proved for the first time the feasibility of establishing a clustered system where WWTPs work as raw materials providers for biorefineries where the DSP is centralized. Finally, the success of the current approach also relies on the use of low-cost extraction processes using surfactants. Under a centralized DSP approach, PHA costs can be lower than 1 €/kg PHA.

Declaration of Competing Interest

The authors declare that they have no known competing financial interests or personal relationships that could have appeared to influence the work reported in this paper.

Data availability

No data was used for the research described in the article.

Acknowledgments

This research work has been financially supported through the TREASURE (CTQ2017-83225-C2-1-R), ECOPLYVER (PID2020-112550RB-C21), and the USABLE Packaging projects (Call: H2020-BBI-JTI-2018, EU ID: 836884). Alba Roibás-Rozas, Mateo Saavedra del Oso, Anuska Mosquera and Almudena Hospido belong to a Galician Competitive Research Group (GRC ED431C 2021/37), programme cofunded by FEDER (UE). Finally, Alba Roibás-Rozas acknowledges CRE-TUS for supporting her research stay at the Delft University of Technology.

Appendix A. Supplementary data

Supplementary data to this article can be found online at <https://doi.org/10.1016/j.cej.2023.144819>.

References

- [1] A. Surendran, M. Lakshmanan, J.Y. Chee, A.M. Sulaiman, D. van Thuoc, K. Sudesh, Can Polyhydroxyalkanoates be produced efficiently from waste plant and animal oils? *Front. Bioeng. Biotechnol.* 8 (2020) 169, <https://doi.org/10.3389/fbioe.2020.00169/BIBTEX>.
- [2] R. Sawangkeaw, S. Ngamprasertsith, A review of lipid-based biomasses as feedstocks for biofuels production, *Renew. Sustain. Energy Rev.* 25 (2013) 97–108, <https://doi.org/10.1016/j.rser.2013.04.007>.
- [3] M. Atasoy, I. Owusu-Agyeman, E. Plaza, Z. Cetecioglu, Bio-based volatile fatty acid production and recovery from waste streams: Current status and future challenges, *Bioresour. Technol.* 268 (2018) 773–786, <https://doi.org/10.1016/j.biortech.2018.07.042>.
- [4] B. Yadav, A. Pandey, L.R. Kumar, R.D. Tyagi, Bioconversion of waste (water)/residues to bioplastics- A circular bioeconomy approach, *Bioresour. Technol.* 298 (2020), 122584, <https://doi.org/10.1016/j.biortech.2019.122584>.
- [5] M. Saavedra del Oso, A. Regueira, A. Hospido, M. Mauricio-Iglesias, Fostering the valorization of organic wastes into carboxylates by a computer-aided design tool, *Waste Manag.* 142 (2022) 101–110, <https://doi.org/10.1016/j.wasman.2022.02.008>.

⁴ <https://biogroup.usc.es/ecopolyver>.

- [6] M. Saavedra del Oso, M. Mauricio-Iglesias, A. Hospido, Evaluation and optimization of the environmental performance of PHA downstream processing, *Chem. Eng. J.* 412 (2021), 127687, <https://doi.org/10.1016/J.CEJ.2020.127687>.
- [7] L. Argiz, A. Fra-Vázquez, Á.V. del Río, A. Mosquera-Corral, Optimization of an enriched mixed culture to increase PHA accumulation using industrial saline complex wastewater as a substrate, *Chemosphere* 247 (2020) 125873.
- [8] L. Argiz, R. Gonzalez-Cabaleiro, D. Correa-Galeote, A. Val del Río, A. Mosquera-Corral, Open-culture biotechnological process for triacylglycerides and polyhydroxyalkanoates recovery from industrial waste fish oil under saline conditions, *Sep. Purif. Technol.* 270 (2021), <https://doi.org/10.1016/j.seppur.2021.118805>, 118805.
- [9] L. Argiz, R. González-Cabaleiro, Á. Val del Río, J. González-López, A. Mosquera-Corral, A novel strategy for triacylglycerides and polyhydroxyalkanoates production using waste lipids, *Sci. Total Environ.* 763 (2020), 142944, <https://doi.org/10.1016/j.scitotenv.2020.142944>.
- [10] A. Roibás-Rozas, A. Val del Río, A. Hospido, A. Mosquera-Corral, Strategies for the valorisation of a protein-rich saline waste stream into polyhydroxyalkanoates (PHA), *Bioresour. Technol.* 334 (2021), 124964, <https://doi.org/10.1016/J.BIORTECH.2021.124964>.
- [11] A. Roibás-Rozas, A. Mosquera-Corral, A. Hospido, Environmental assessment of complex wastewater valorisation by polyhydroxyalkanoates production, *Sci. Total Environ.* 744 (2020), <https://doi.org/10.1016/j.scitotenv.2020.140893>, 140893.
- [12] F. Piccinno, R. Hischer, S. Seeger, C. Som, From laboratory to industrial scale: a scale-up framework for chemical processes in life cycle assessment studies, *J. Clean Prod.* 135 (2016) 1085–1097, <https://doi.org/10.1016/J.JCLEPRO.2016.06.164>.
- [13] International Standard Organization, ISO 14040:2006 - Environmental management — Life cycle assessment — Principles and framework, (2006). <https://www.iso.org/standard/37456.html>.
- [14] ecoinvent Database – ecoinvent, (n.d.). <https://ecoinvent.org/the-ecoinvent-database/> (accessed August 1, 2022).
- [15] A. Roibás-Rozas, M. Saavedra del Oso, G. Zarroli, M. Mauricio-Iglesias, A. Mosquera-Corral, S. Fiore, A. Hospido, How can we validate the environmental profile of bioplastics? Towards the introduction of polyhydroxyalkanoates (PHA) in the value chains, *Assessing Progress Towards Sustainability.* (2022) 405–429. <https://doi.org/10.1016/B978-0-323-85851-9.00010-9>.
- [16] ReCiPe - PRé Sustainability, (n.d.). <https://pre-sustainability.com/articles/recipe/> (accessed August 1, 2022).
- [17] M.Z. Hauschild, R.K. Rosenbaum, S.I. Olsen, *Life Cycle Assessment: Theory and Practice*, Springer International Publishing (2017), <https://doi.org/10.1007/978-3-319-56475-3>.
- [18] W.D. Seider, D.R. Lewin, J.D. Seader, S. Widagdo, R. Gani, K.M. Ng, *Product and process design principles: synthesis, analysis, and evaluation*, Fourth ed, 2016.
- [19] P.M. Bello Bugallo, A. Stupak, L. Cristóbal Andrade, R. Torres López, Material flow analysis in a cooked mussel processing industry, *J. Food Eng.* 113 (2012) 100–117, <https://doi.org/10.1016/j.jfoodeng.2012.05.014>.
- [20] M.C. Barros, A. Magán, S. Valiño, P.M. Bello, J.J. Casares, J.M. Blanco, Identification of best available techniques in the seafood industry: a case study, *J. Clean. Prod.* 17 (2009) 391–399, <https://doi.org/10.1016/j.jclepro.2008.08.012>.
- [21] Secretaría xeral de Calidade de Avaluación Ambiental, 2012-IPPC-I-14, 2013.
- [22] J. Park, M. Kim, B. Nam, H. Chang, D. Kim, Behavior of Surfactants in Oil Extraction by Surfactant-Assisted Acidic Hydrothermal Process from *Chlorella vulgaris*, *Appl. Biochem. Biotechnol.* (2021) 319–334, [10.1007/s12010-020-03426-3](https://doi.org/10.1007/s12010-020-03426-3).
- [23] P. Illukpitiya, J.P. de Koff, Economics of small-scale biodiesel production, *Bioenergy.* 7–9 (2014).
- [24] statista, Price of high-density polyethylene worldwide from 2017 to 2020 with estimated figures for 2021 to 2022, (2021).
- [25] M. González-López, Innovation patterns in the canned fish industry in Galicia (Spain), *J. Entrepreneurship Manage. Innov.* 14 (2018) 45–64, <https://doi.org/10.7341/20181413>.
- [26] C. Fernández-Dacosta, J.A. Posada, R. Kleerebezem, M.C. Cuellar, A. Ramirez, Microbial community-based polyhydroxyalkanoates (PHAs) production from wastewater: Techno-economic analysis and ex-ante environmental assessment, *Bioresour. Technol.* 185 (2015) 368–377, <https://doi.org/10.1016/j.biortech.2015.03.025>.
- [27] S. Bengtsson, A. Karlsson, T. Alexandersson, L. Quadri, M. Hjort, P. Johansson, F. Morgan-Sagastume, S. Anterrieu, M. Arcos-Hernandez, L. Karabegovic, P. Magnusson, A. Werker, A process for polyhydroxyalkanoate (PHA) production from municipal wastewater treatment with biological carbon and nitrogen removal demonstrated at pilot-scale, *N. Biotechnol.* 35 (2017) 42–53, <https://doi.org/10.1016/J.NBT.2016.11.005>.
- [28] D. Crutchik, O. Franchi, L. Caminos, D. Jeison, M. Belmonte, A. Pedrouso, A. Val del Río, A. Mosquera-Corral, J.L. Campos, Polyhydroxyalkanoates (PHAs) production: A feasible economic option for the treatment of sewage sludge in municipal wastewater treatment plants? *Water (Switzerland)*. 12 (2020) 1–12, <https://doi.org/10.3390/W12041118>.
- [29] V. Pérez, R. Lebrero, R. Muñoz, Comparative Evaluation of Biogas Valorization into Electricity/Heat and Poly(hydroxyalkanoates) in Waste Treatment Plants: Assessing the Influence of Local Commodity Prices and Current Biotechnological Limitations, *ACS Sustain. Chem. Eng.* 8 (2020) 7701–7709, <https://doi.org/10.1021/acssuschemeng.0c01543>.
- [30] V. Pérez, C.R. Mota, R. Muñoz, R. Lebrero, Polyhydroxyalkanoates (PHA) production from biogas in waste treatment facilities: Assessing the potential impacts on economy, environment and society, *Chemosphere* 255 (2020) 126929.
- [31] L. Vogli, S. Macrelli, D. Marazza, P. Galletti, C. Torri, C. Samori, S. Righi, Life cycle assessment and energy balance of a novel polyhydroxyalkanoates production process with mixed microbial cultures fed on pyrolytic products of wastewater treatment sludge, *Energies (Basel)*. 13 (11) (2020) 2706.
- [32] R. Arvidsson, A.M. Tillman, B.A. Sandén, M. Janssen, A. Nordelöf, D. Kushnir, S. Molander, Environmental assessment of emerging technologies: recommendations for prospective LCA, *J. Ind. Ecol.* 22 (2018) 1286–1294, <https://doi.org/10.1111/JIEC.12690>.
- [33] S. Cucurachi, C. van der Giesen, J. Guinée, Ex-ante LCA of emerging technologies, *Procedia CIRP*. 69 (2018) 463–468, <https://doi.org/10.1016/j.procir.2017.11.005>.
- [34] G. Thomassen, M. van Dael, S. van Passel, F. You, How to assess the potential of emerging green technologies? Towards a prospective environmental and techno-economic assessment framework, *Green Chem.* 21 (2019) 4868–4886, <https://doi.org/10.1039/C9GC02223F>.
- [35] M. Saavedra del Oso, M. Mauricio-Iglesias, A. Hospido, B. Steubing, Prospective LCA to provide environmental guidance in the development of waste-to-PHA biorefineries, *J. Clean. Prod.* 383 (2022), <https://doi.org/10.1016/j.jclepro.2022.135331>.