

**GROUND LEVEL**

*Water way*

- bar 'ketelhuis'
- changing rooms
- toilets
- swimmingpool
- thermal baths
- helophyte filter swimmingpool
- water buffer
- exhibition maze
- bike rent

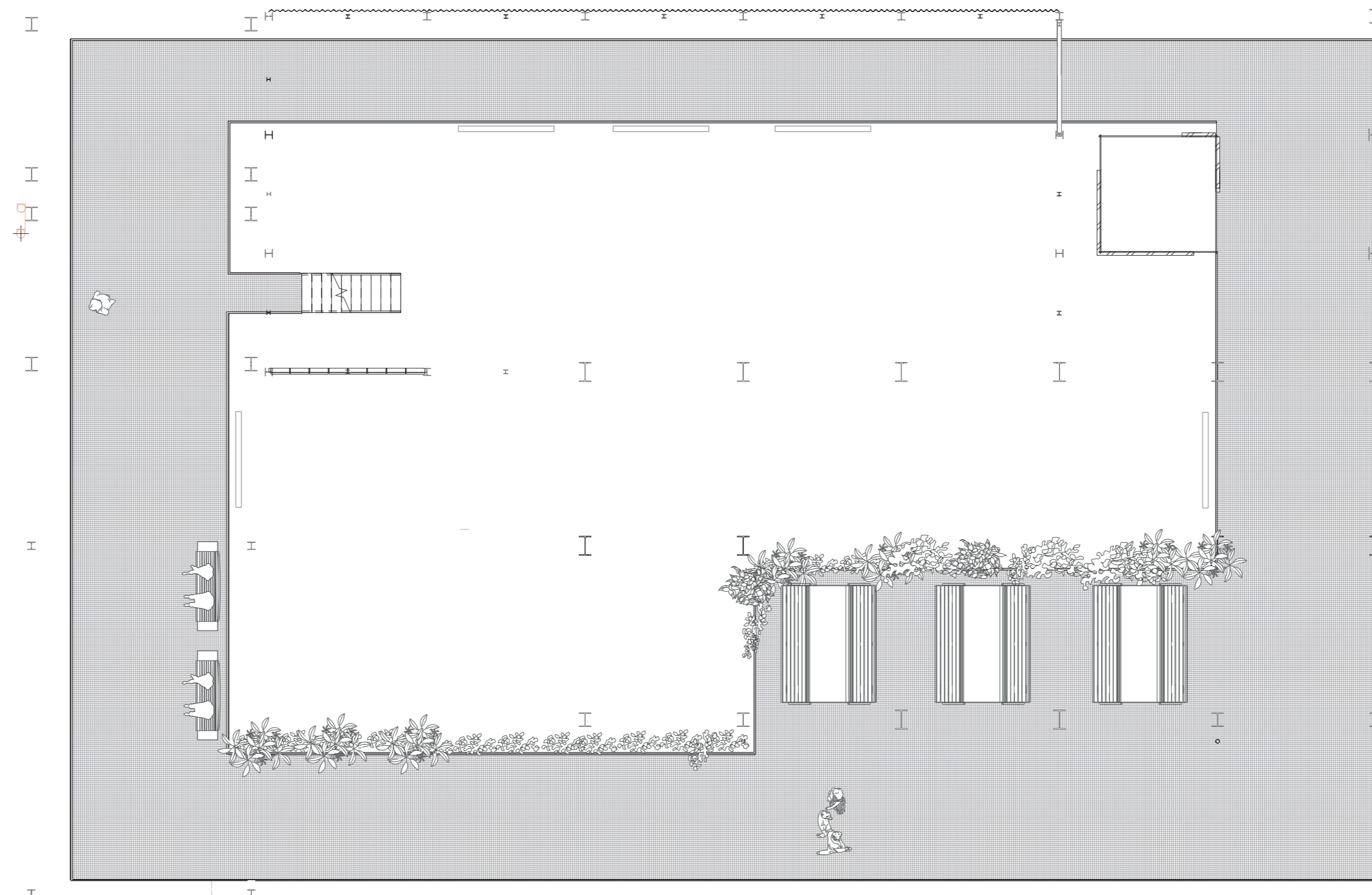

**FIRST LEVEL**

*Information deck*

6000+

- information panels
- picnick tables

**SECOND LEVEL**  
*Office/archive*  
9000+  
multifunctional workspaces

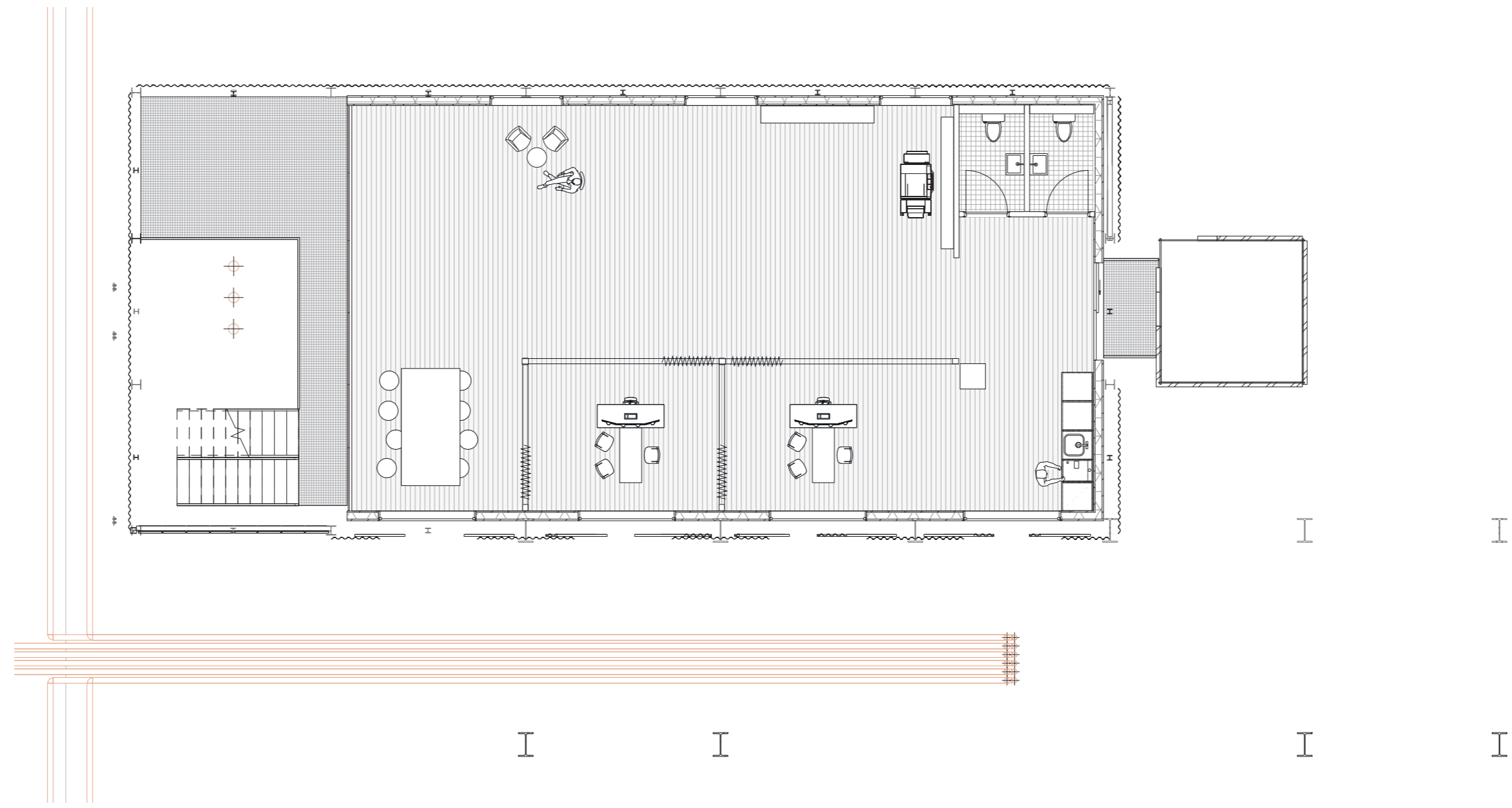

**THIRD LEVEL**  
*Hotel lobby*  
15000+  
toilets  
lobby  
entrance to hotel rooms

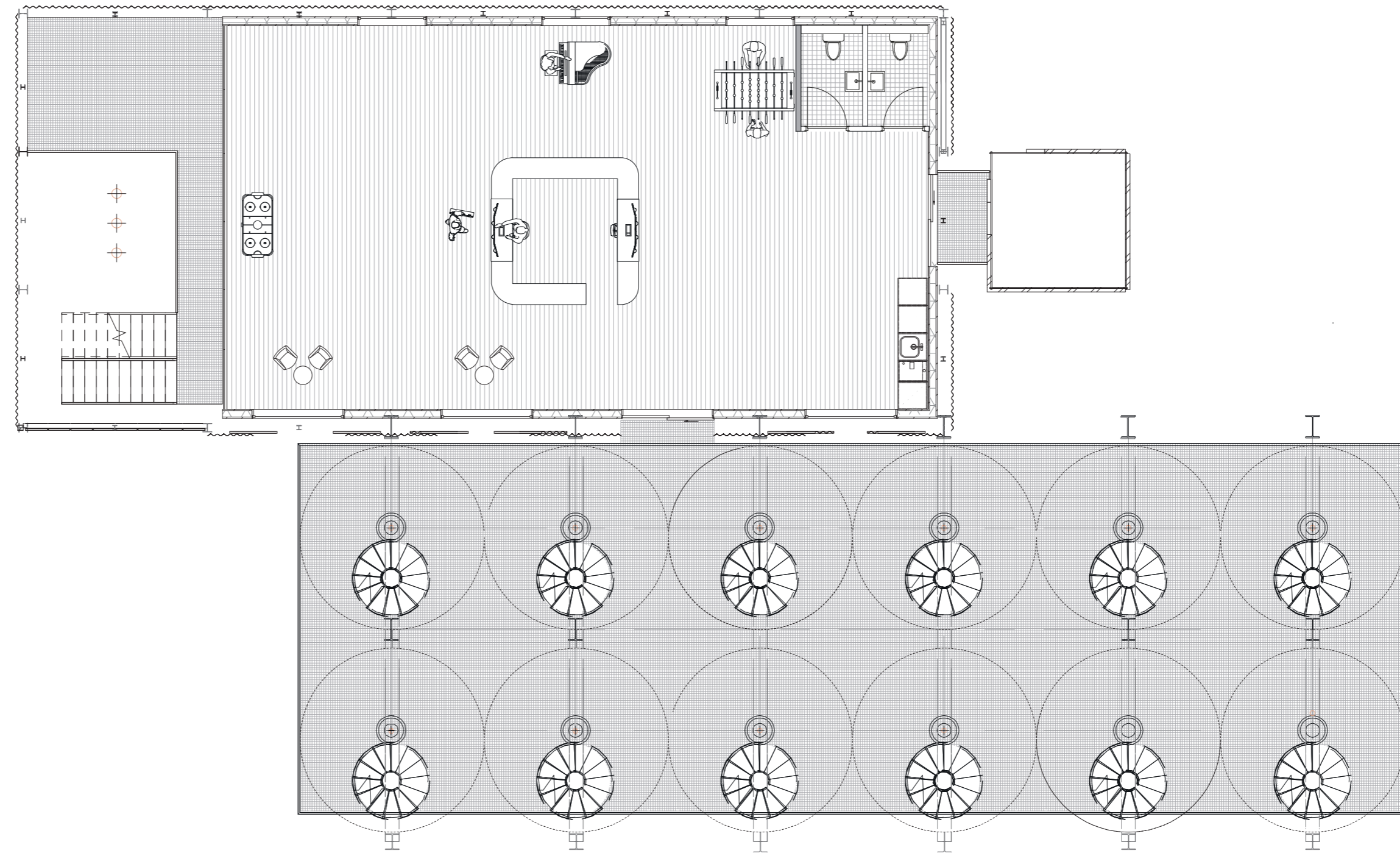

**FOURTH LEVEL**  
*Cinema/theatre*  
18000+  
toilets  
moveable sitplaces

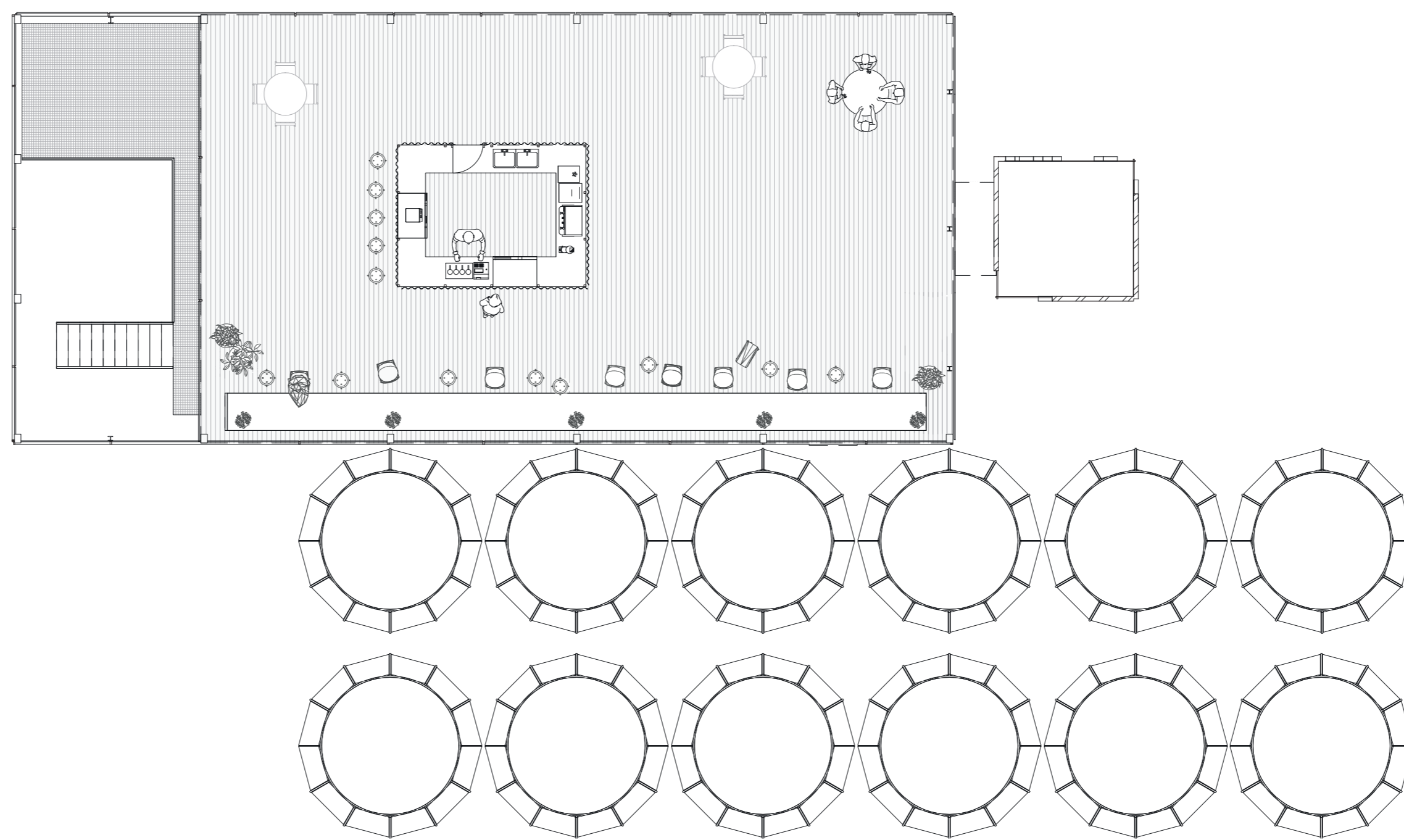

**FIFTH LEVEL**  
*Observation deck*  
24000+

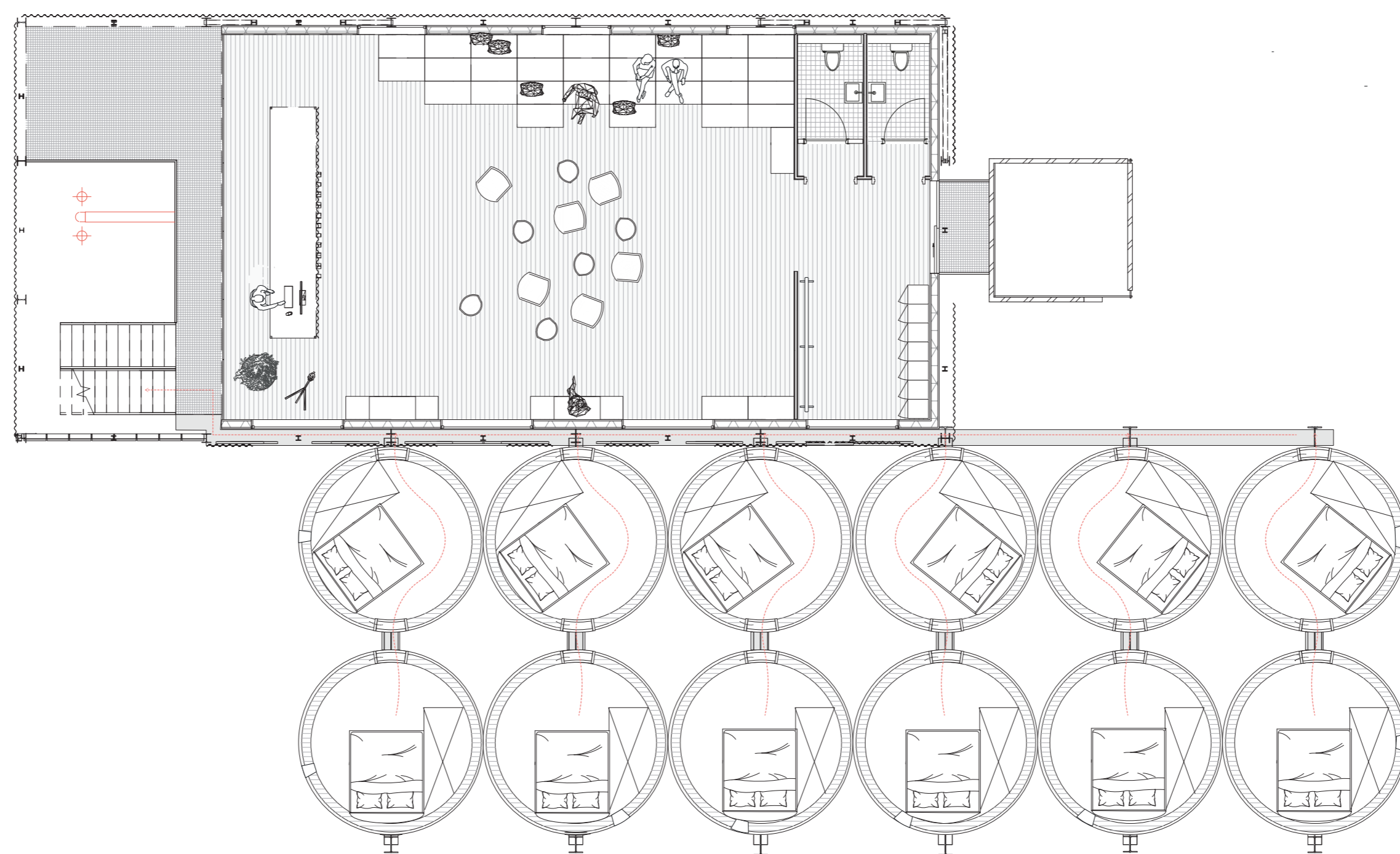

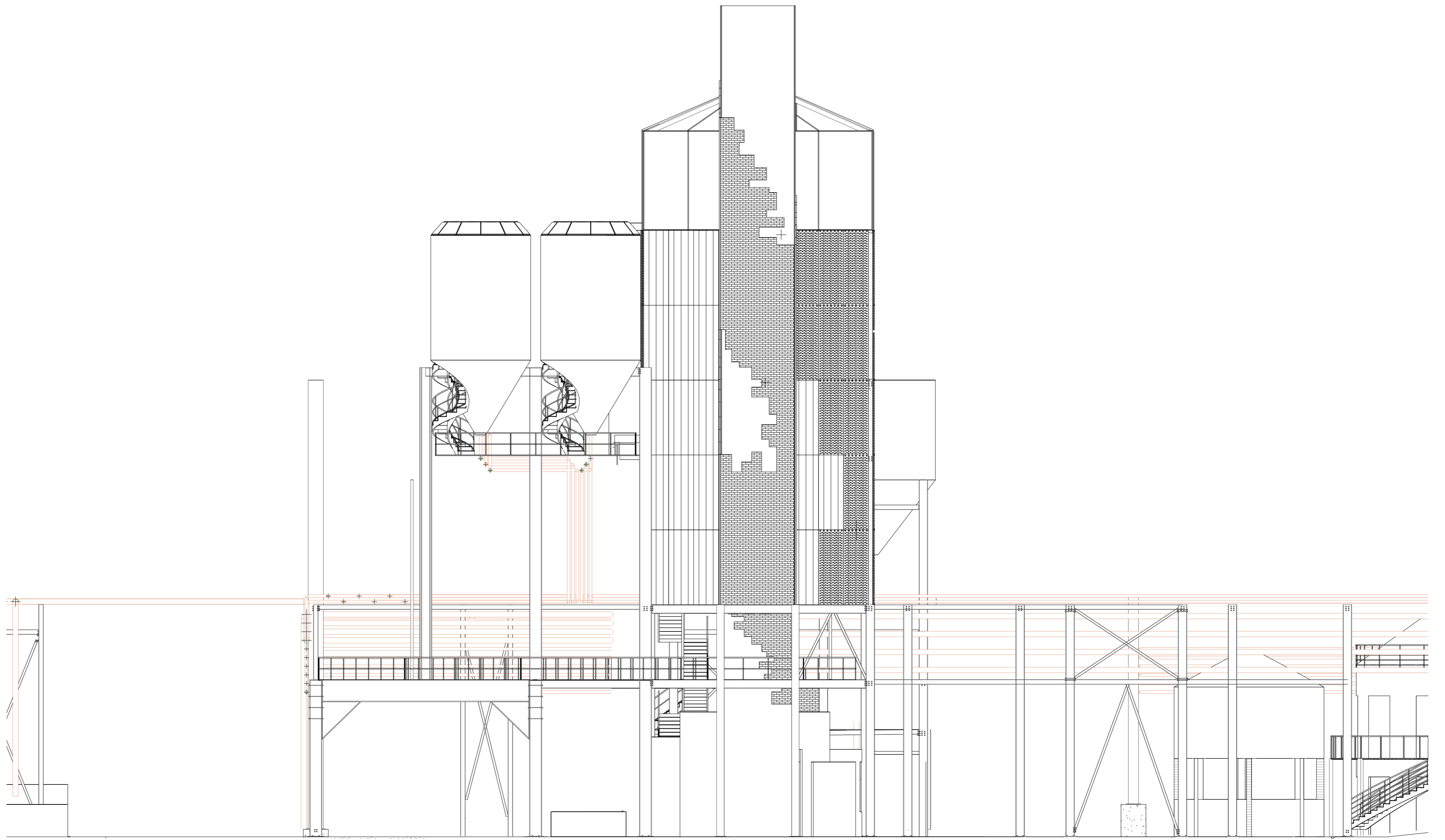

**EAST FACADE**

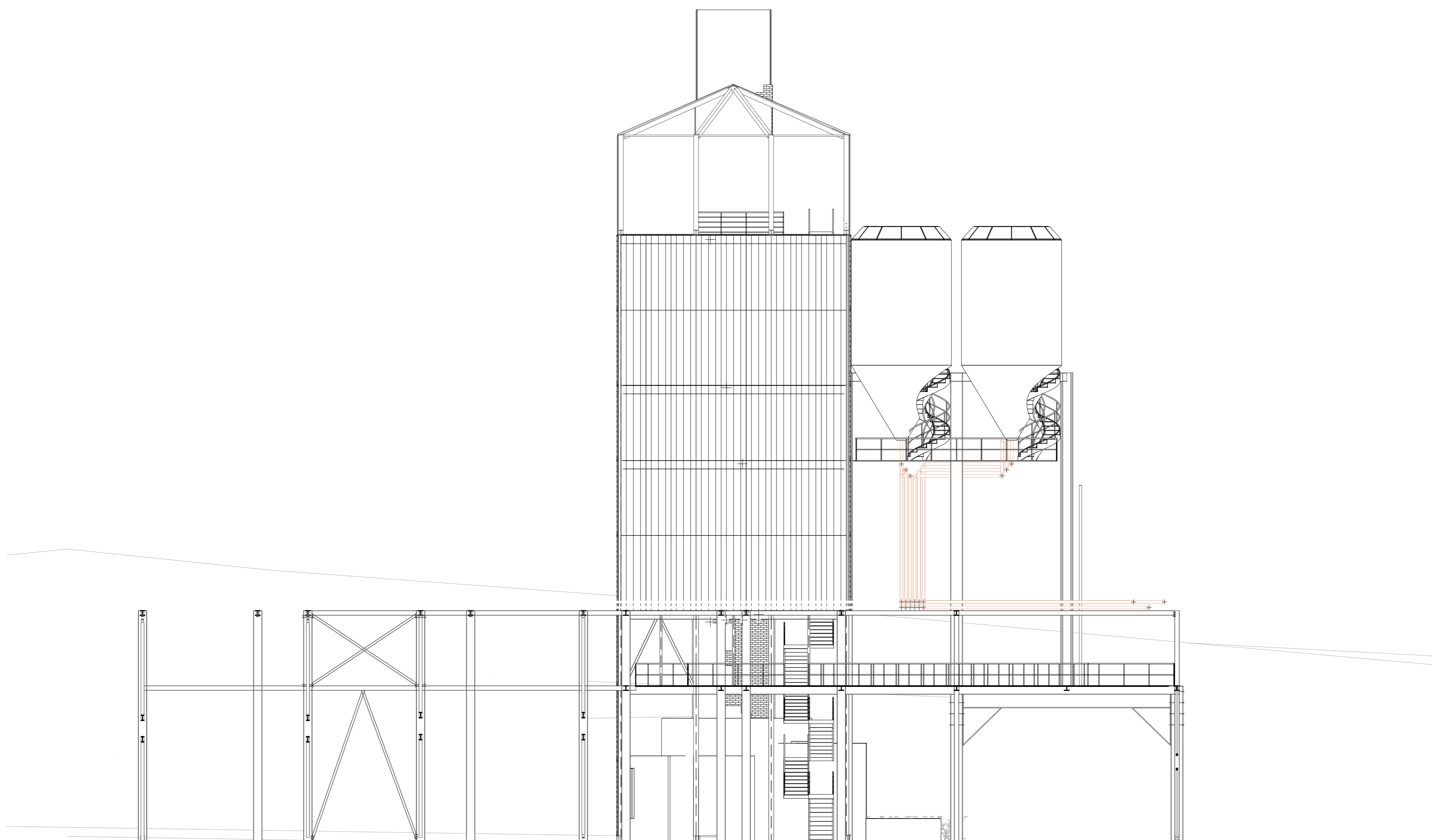

**WEST FACADE**

*Low tech climate facade*

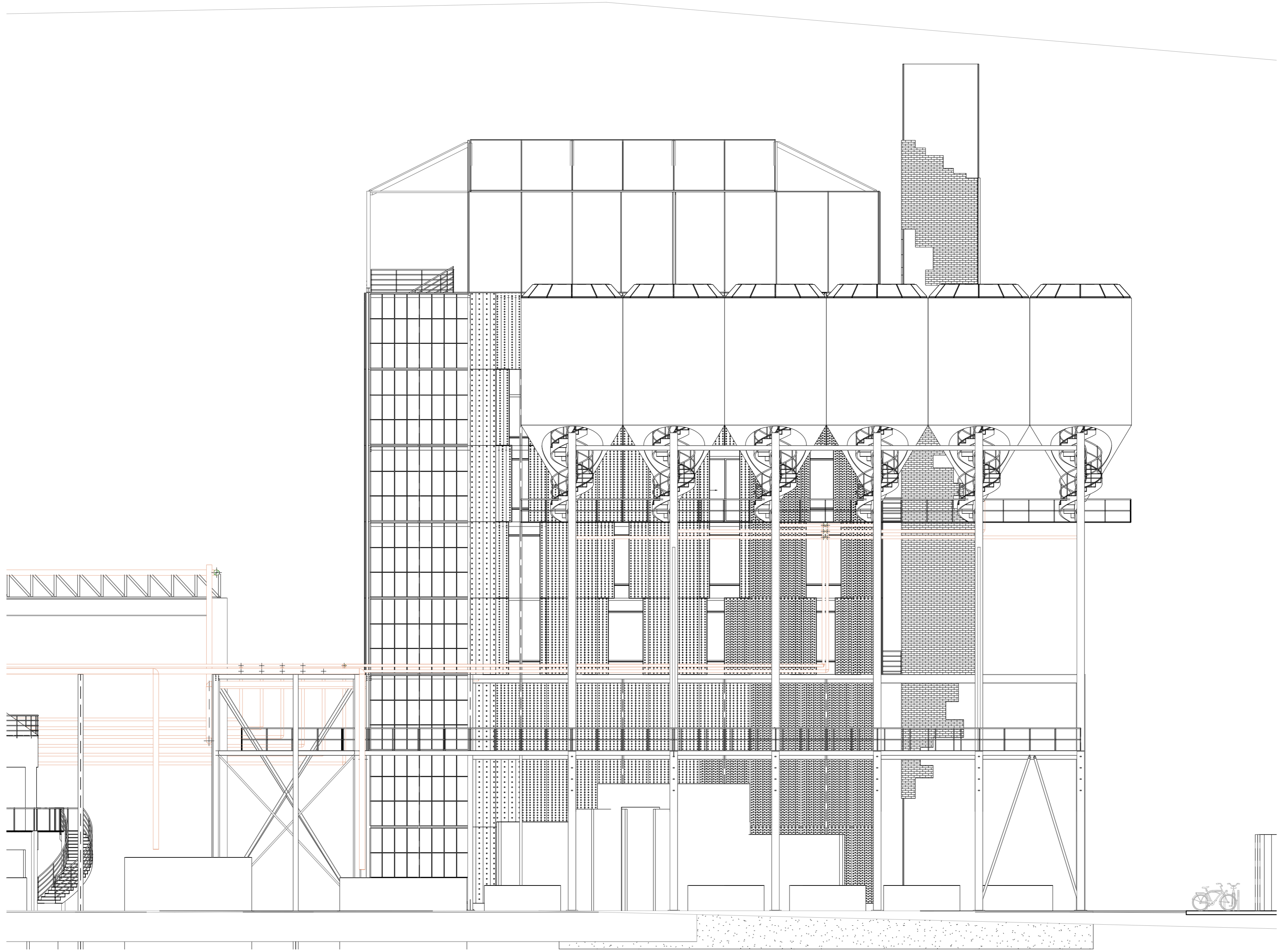

**SOUTH FACADE**  
*Flexible facade*

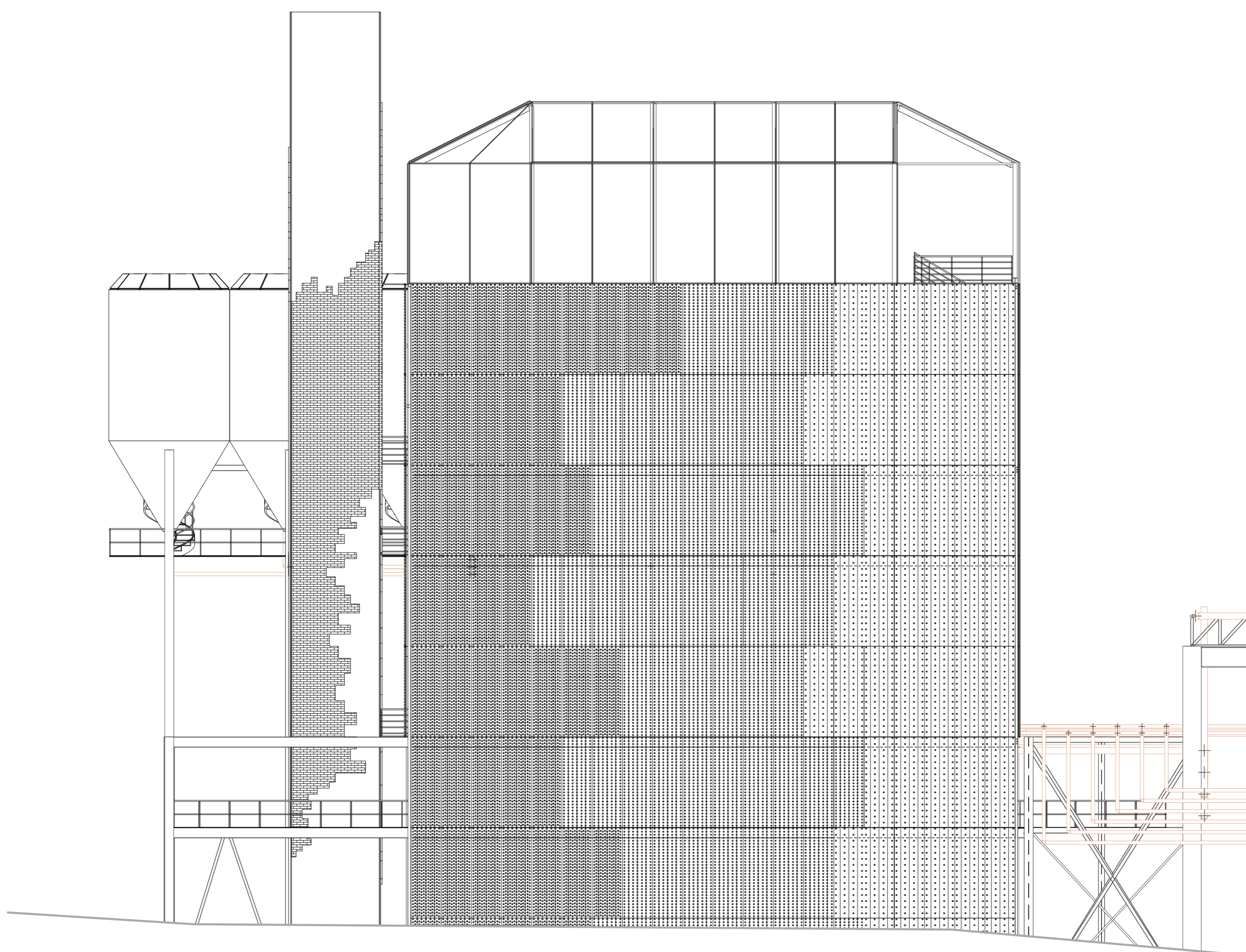

**NORTH FACADE**  
*Closed facade*

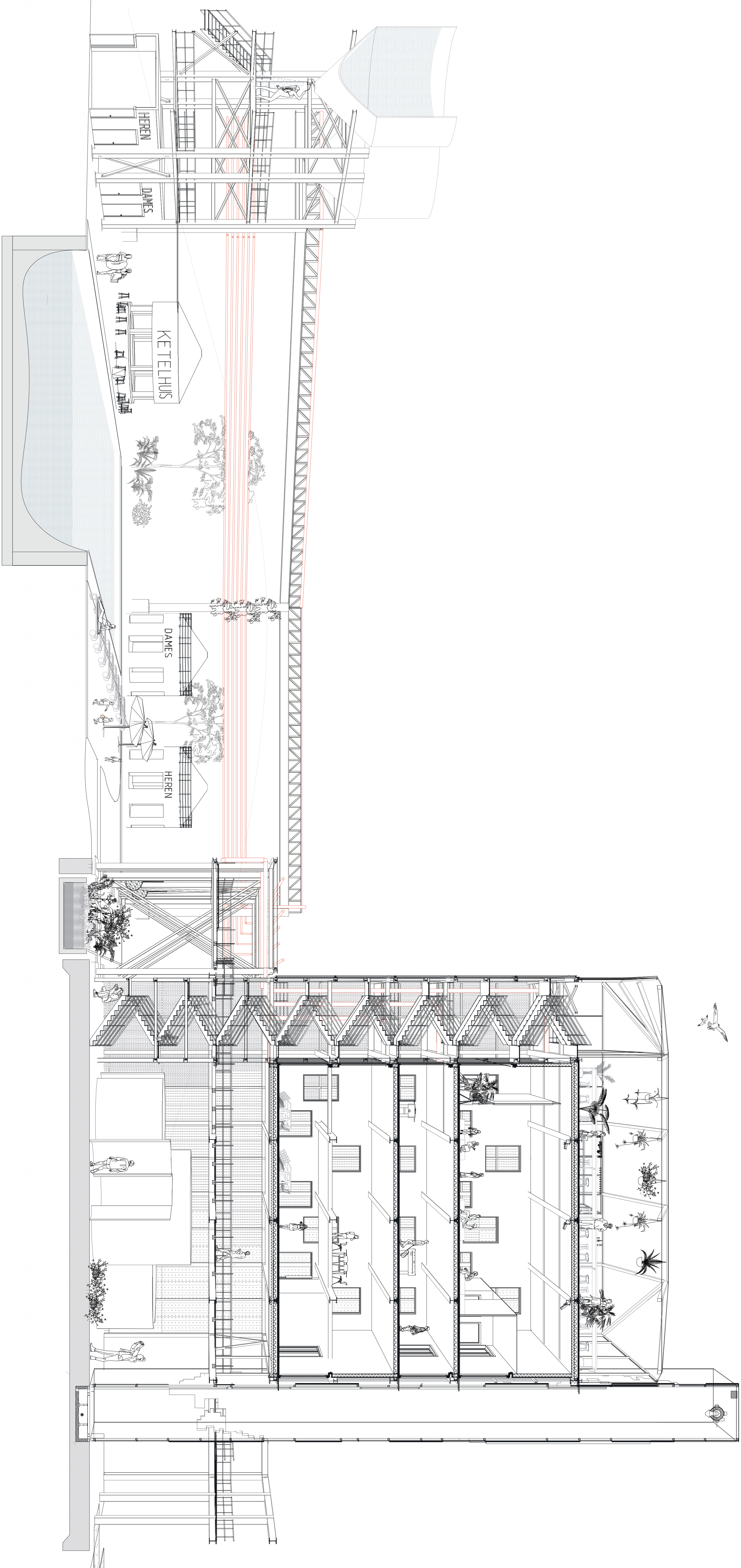

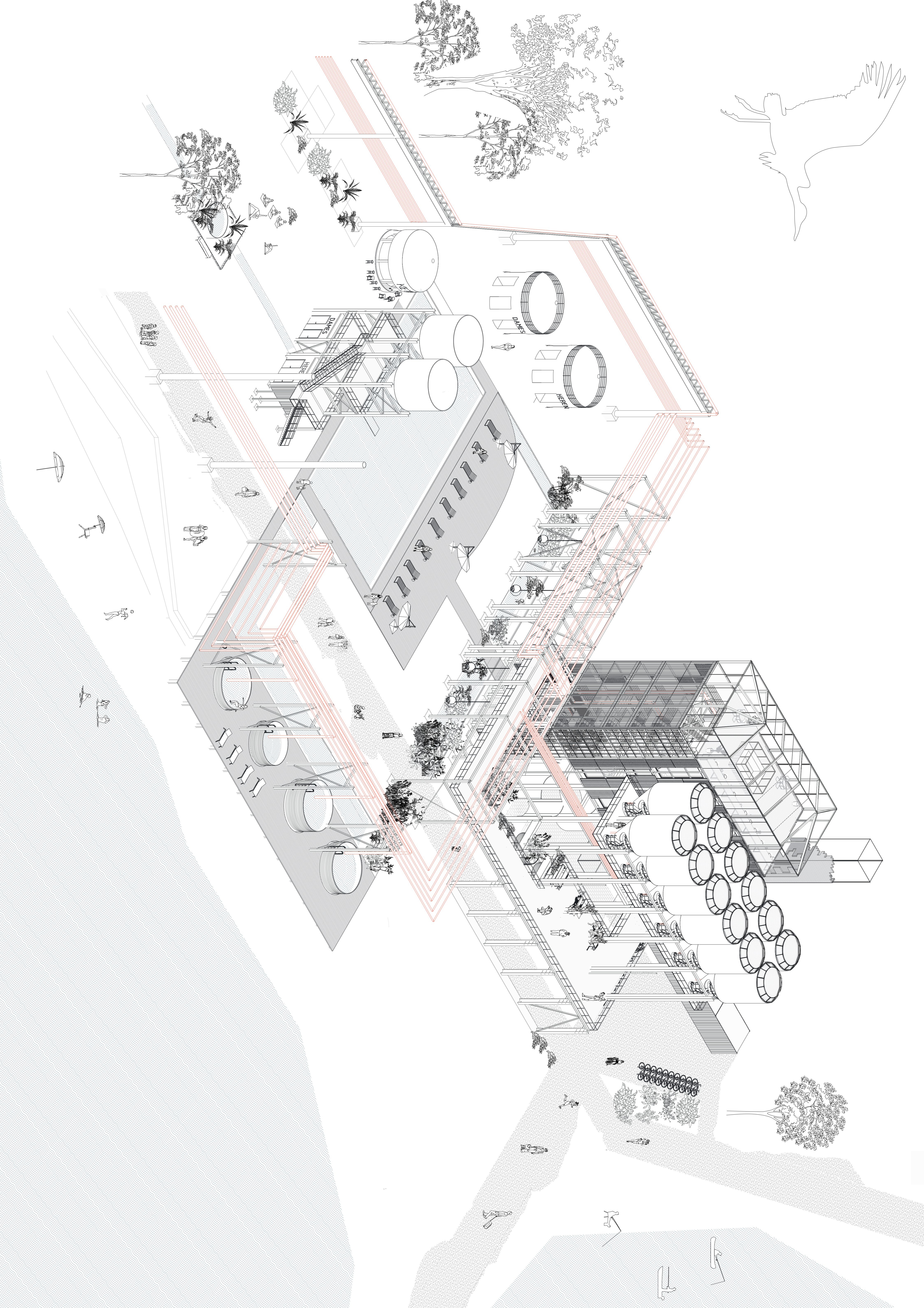

**DETAIL A 1:5**  
Skylight Silo Room

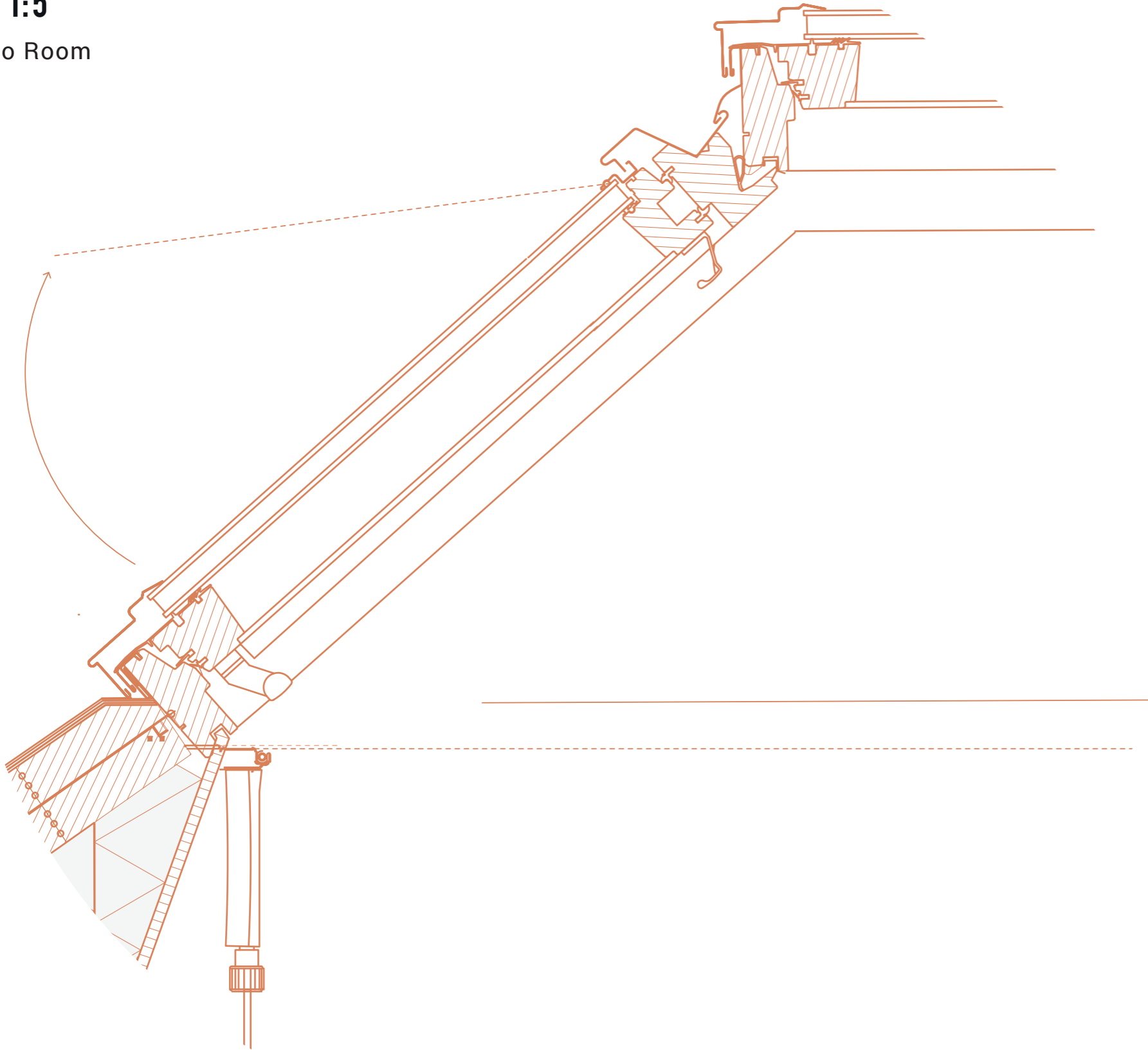

**DETAIL B 1:5**  
Entrance Silo Room

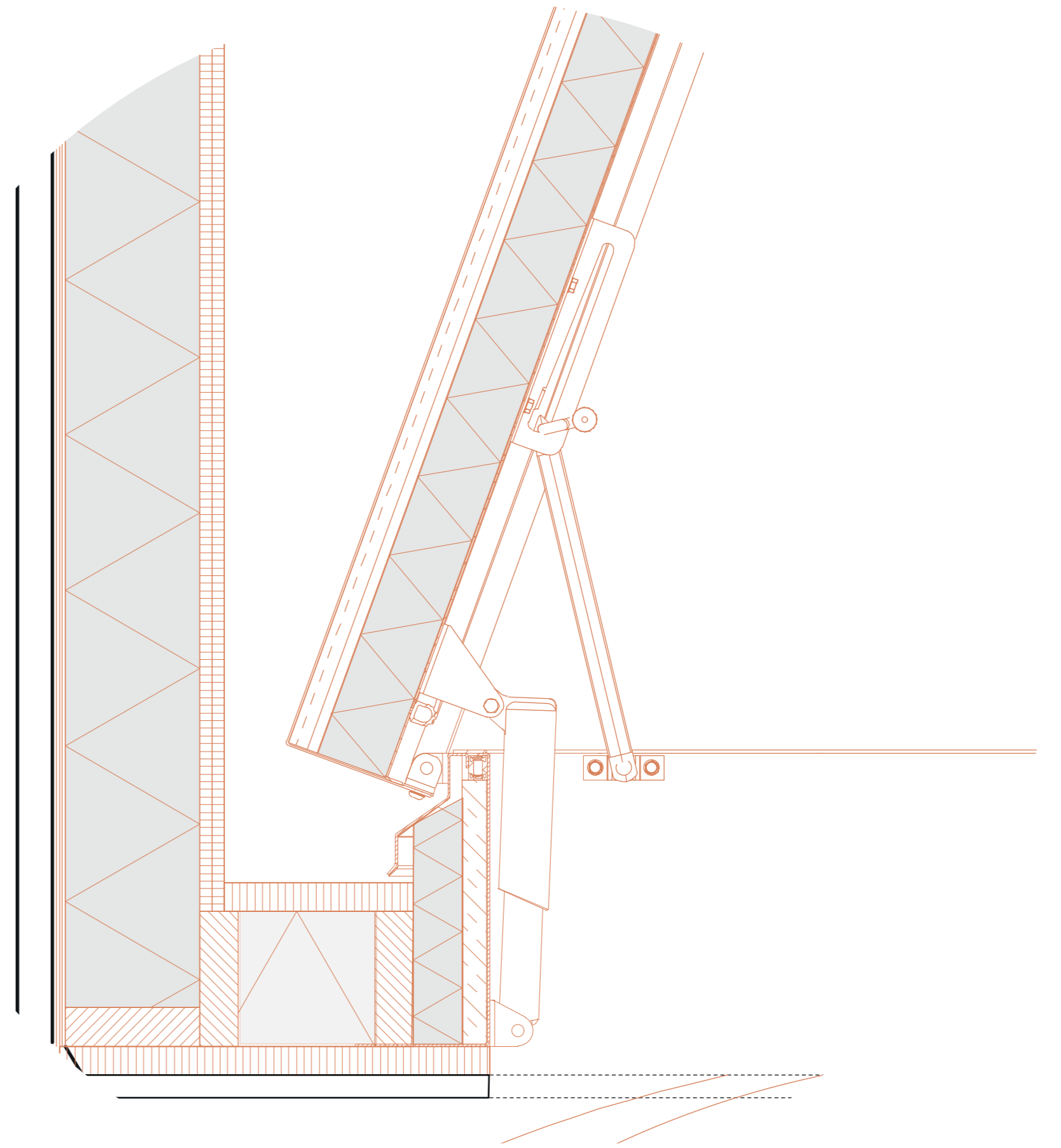

**DETAIL C 1:5**  
Observation desk:  
connection new to existing

Façade:  
Water membrane  
Double layer fibreboard  
insulation panels  
Vapour barrier

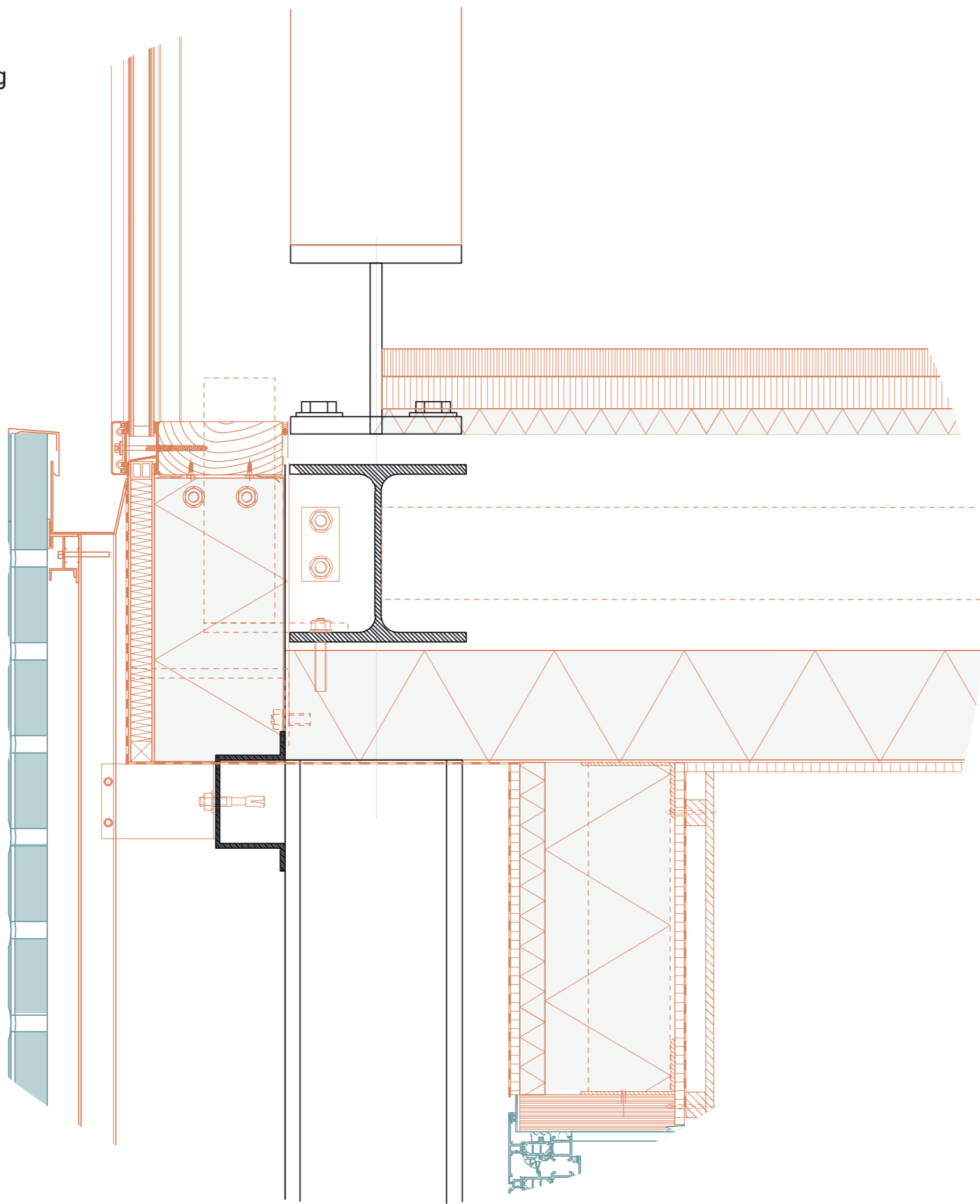

**DETAIL D 1:5**

Floor:  
Hardwood flooring  
(pine)  
Heating system  
Heat conduction plate  
30 mm softwood fibre  
Support with pre-milled  
grooves  
Comfloor 100 filled  
with sand harvested  
from the site

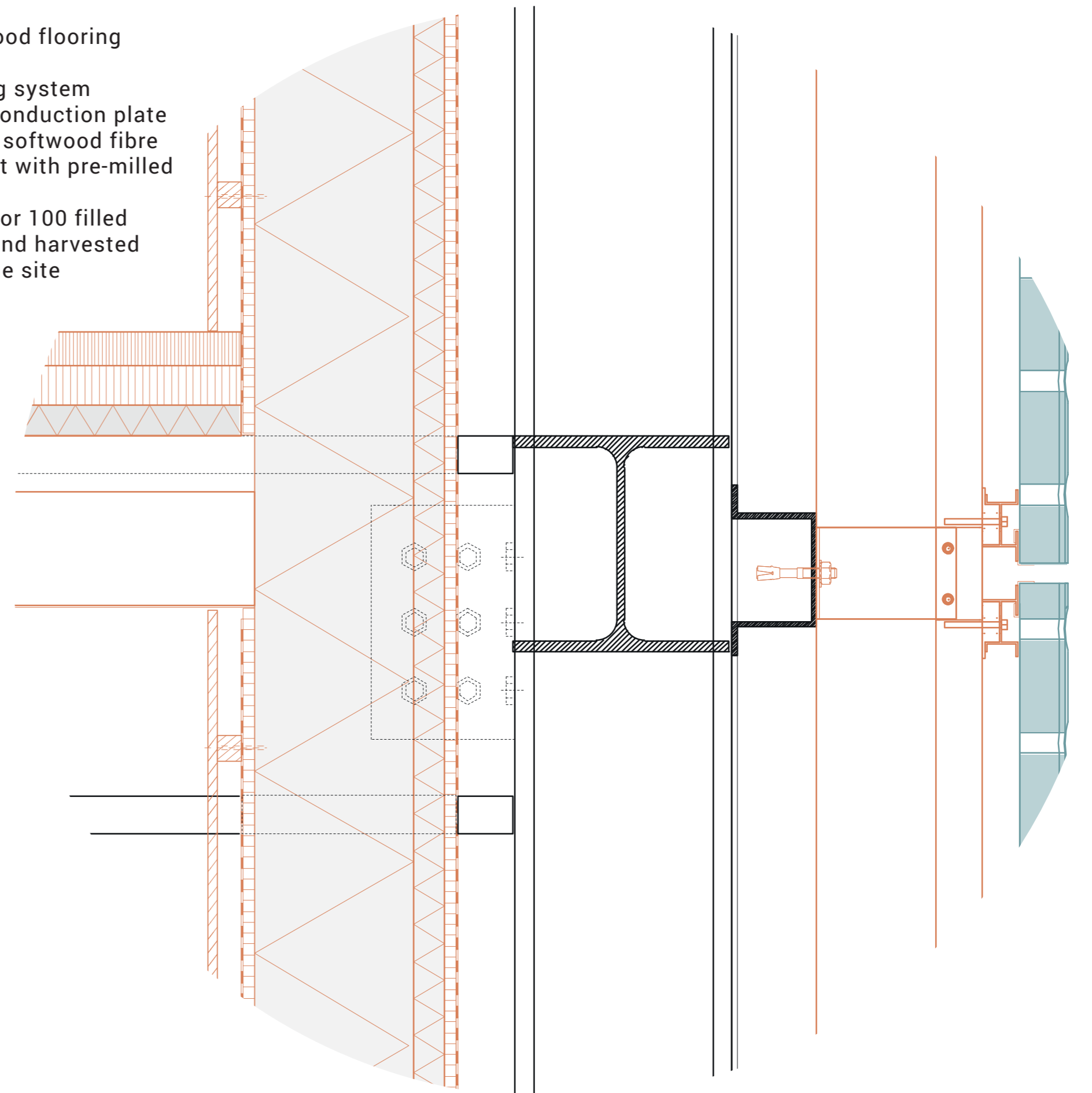

**DETAIL E 1:5**

South façade:  
Perforated corrugated  
steel sliding shutter  
(reused) on a steel  
Frame  
Track  
Hanger  
Floor guide

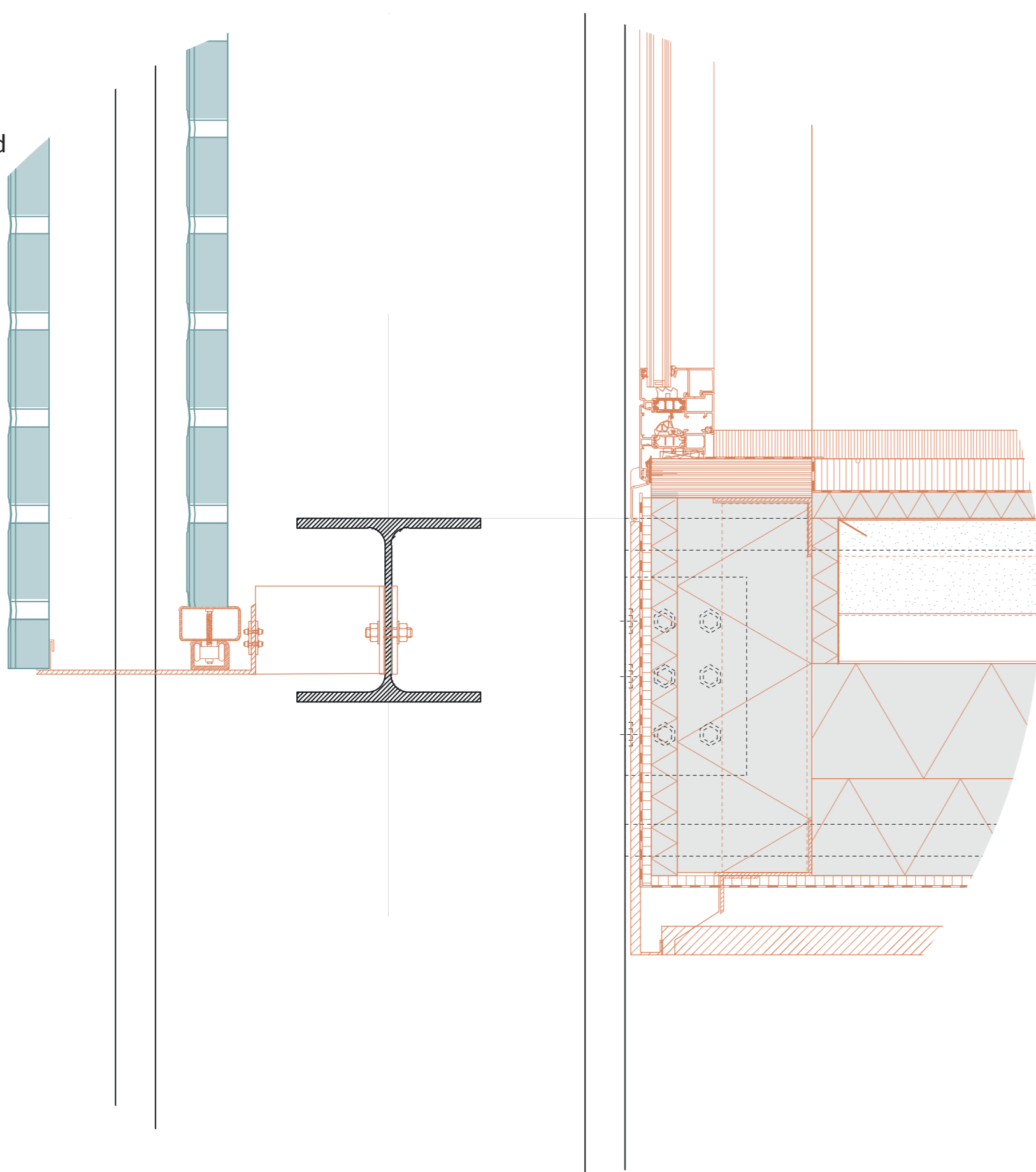

**DETAIL F 1:5**

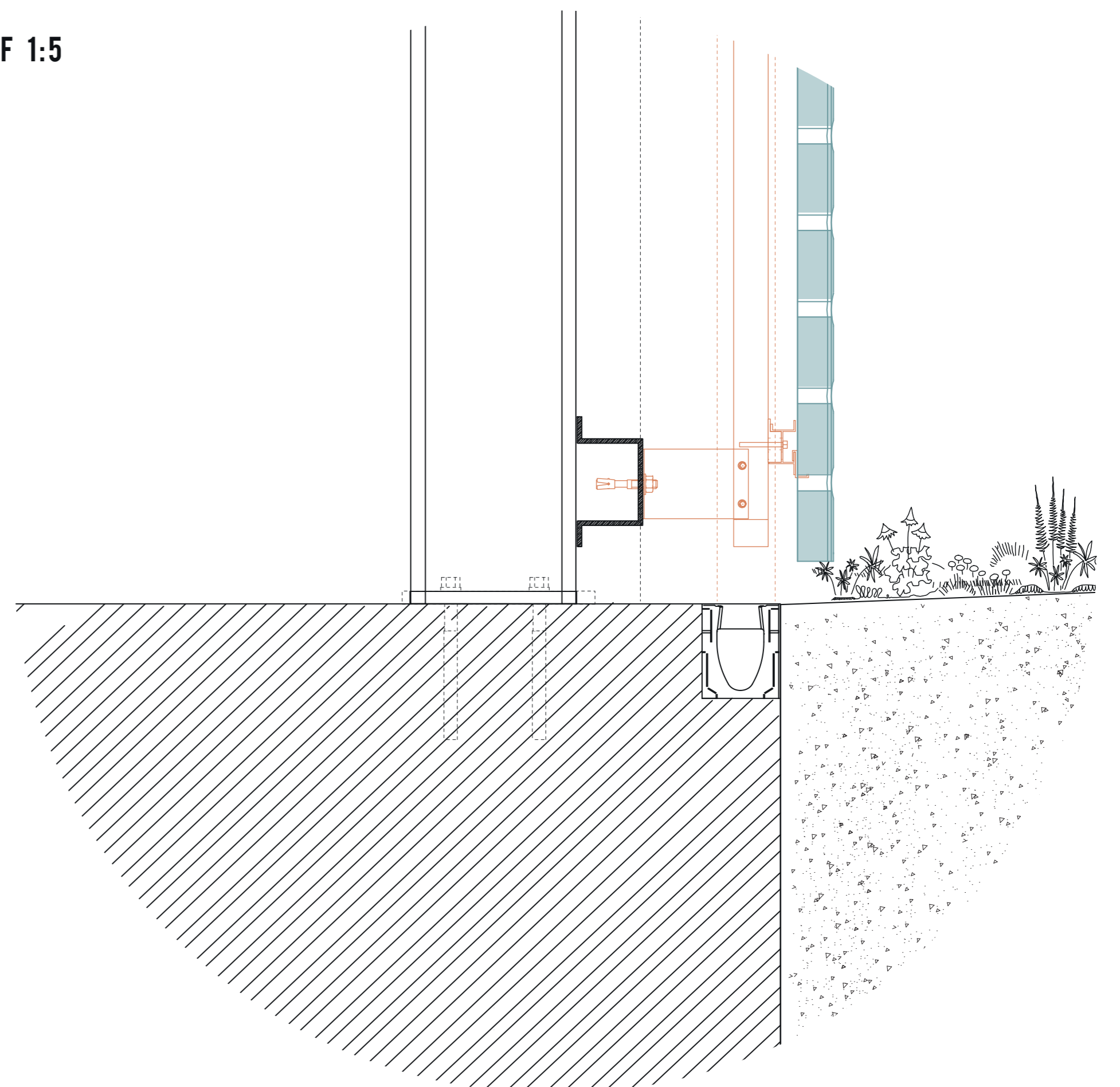

DETAIL 1:20

