

## **Circular composites**

### **A design guide for products containing composite materials in a circular economy**

Joustra, J.J.; Bessai, R.

#### **Publication date**

2021

#### **Document Version**

Final published version

#### **Citation (APA)**

Joustra, J. J., & Bessai, R. (Eds.) (2021). *Circular composites: A design guide for products containing composite materials in a circular economy*.

#### **Important note**

To cite this publication, please use the final published version (if applicable).  
Please check the document version above.

#### **Copyright**

Other than for strictly personal use, it is not permitted to download, forward or distribute the text or part of it, without the consent of the author(s) and/or copyright holder(s), unless the work is under an open content license such as Creative Commons.

#### **Takedown policy**

Please contact us and provide details if you believe this document breaches copyrights.  
We will remove access to the work immediately and investigate your claim.

# Circular Composites

A design guide for products  
containing composite materials  
in a circular economy





# Circular Composites

A design guide for products containing composite materials in a circular economy

Jelle Joustra  
Riel Bessai

Delft, 2021

# Foreword

Composites are increasingly used to optimize the performance of applications as their properties can be tuned to achieve the desired functionality. This leads to lightweight structures that allow for improved strength while reducing material usage in areas like furniture and construction. In other areas, like automotive and aerospace, the energy consumption during use can be reduced. And they fulfill a crucial role in the generation of renewable energy by enabling increasingly large wind turbines.

The sustainability advantages during the use phase are not yet matched by lower impacts in the lifecycle of composite materials and products. In a circular economy this is problematic. At the end of a lifecycle composites are usually land-filled or incinerated, discarding all functionality and value they presented.

Design strategies for circular design of composite products are therefore urgently needed. This book will serve as a guide to designers who want to contribute with innovative and effective solutions. Circular recovery strategies, ranging from reuse to restructuring and recycling, are connected to the design process and concrete design approaches. By providing clear design guidelines and illustrative examples in a structured way the information is readily accessible and applicable to designers.

Changing the way in which we deal with composites is a necessity. This book translates academic insights in actionable principles for designers in practice.

Ruud Balkenende,  
*Professor of Circular Product Design, Technische Universiteit Delft*

# Contents

● ● ● ● ●	<b>Introduction</b>	<b>7</b>
	Introduction	8
	Exploring the value hill	10
	Circular product design framework	11
	About the design process	12
● ● ● ● ●	<b>Circular Strategies</b>	<b>15</b>
	Long life	17
	Lifetime Extension	18
	Product Recovery	19
	Structural Reuse	20
	Recycling	21
● ● ● ● ●	<b>Design Aspects</b>	<b>23</b>
	Concept Design	27
	Embodiment Design	49
	Detail Design	71
● ● ● ● ●	<b>Tools</b>	<b>85</b>
	Life cycle exploration sheet	86
	Disassembly Map	88
	Fastener finder	90
● ● ● ● ●	<b>Closing Remarks</b>	<b>93</b>



Chapter 1

# Introduction





# Introduction

Composite materials are used in an increasing number of applications. While the first modern-day composites emerged in the furniture industry around the middle of the 20th century, their application has expanded dramatically to include the automotive, construction and aviation sectors, to name but a few.

Composites are materials that are composed of two or more constituent materials, which are dissimilar in their chemical and physical properties. These are combined in a composite to achieve properties that are different from those of each individual component. There are many types of composites, and the exact composition can be tailored to a specific application. While this has led to advantageous product properties, such as lightweight designs and long lifetimes, it also presents challenges on recovery and recycling, as the constituent materials are often combined in such a way that makes their separation challenging.

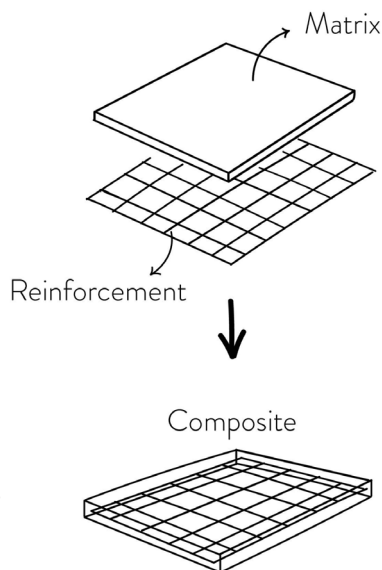

Composite recycling processes tend to break down the composite into its constituent materials, thus losing the specific composite material properties. As these processes severely degrade materials, recycling composites is barely viable economically. Consequently, the majority of composite material is landfilled or incinerated, losing the material and its potential for reuse, depleting resources, and generating waste.

The circular economy offers a promising alternative to lower the environmental burden. It aims to prevent waste by design and to preserve economic and environmental value. Product and material integrity are key concepts in the circular economy and maintaining product functionality has preference over material recovery. Product value can be preserved through long life, lifetime extension, and product recovery approaches, while material value can be preserved through recycling. Thus, the circular economy is a driver for achieving sustainable use of resources.

In the case of composites, the circular economy scheme can largely be applied as far as product integrity is concerned, however material integrity has some distinct aspects. Composite materials enable a long product lifetime because of the resistance to corrosion and fatigue and provide opportunities for lifetime extension through maintenance and repairs.

Recycling remains challenging, which emphasizes the preference for high material integrity recovery strategies. The design process of composite products revolves around the trinity of materials selection, manufacturing and design. Opportunities for reuse and recycling of composites will increase if they are anticipated in the design stage, much in the same way as the materials and design (shape) have to be matched with the manufacturing process. This design guide aims to help integrate circular strategies in the design of composite products.

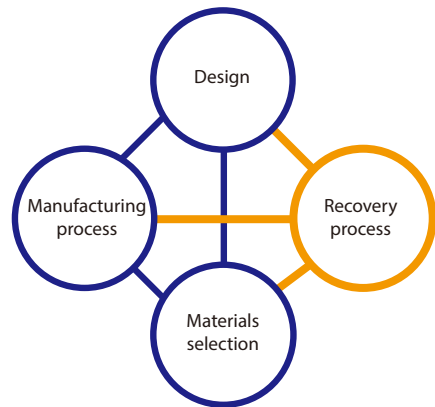

## Reading guide

This guide can be used as a reference work for (re)designing composite products for a circular economy. The design process starts by exploring the product value chain, with stakeholders and interactions. Then, the circular product design framework can be used to detail circular strategies and identify relevant design aspects. This guide provides descriptions of all steps and refers to additional information where applicable.

This guide is developed in Horizon 2020 project Ecobulk, a large scale demonstration effort for composite products in a circular economy. The examples given are developed as demonstrator products for construction, furniture and automotive industry, supplemented by design case studies at Delft University of Technology.

# Exploring the value hill

In today's economy, products are increasingly complex. Typically, the process of making a product starts from extracting raw materials from the earth, and processing the material in different stages, combining components together, until you finish with a product. Value is added at each stage of the production process, including processing of raw materials, fabrication of components, assembly, and distribution to consumers. In a linear economy, once a product has reached the end of its life, it is sent to landfill or is incinerated, quickly losing its value.

A circular economy aims to prevent this loss of value by employing circular strategies to keep the product at its highest value - at the top of the hill - for as long as possible. The product is designed to be longlasting by enabling repair and maintenance. Once the product is truly at its end-of-life, its downhill journey is done as slow as possible, to enable the value to be of service to other systems.

The five strategies discussed in this book are derived from the value hill, and the associated design aspects each help to enable different circular strategies for composite products, thus maximizing value within the system. To explore the value chain of a case product, use the exploration sheet in Chapter 4. This sheet can be used to map out the current lifecycle, stakeholders and potential recovery loops, which provides a starting point for selecting appropriate circular strategies.

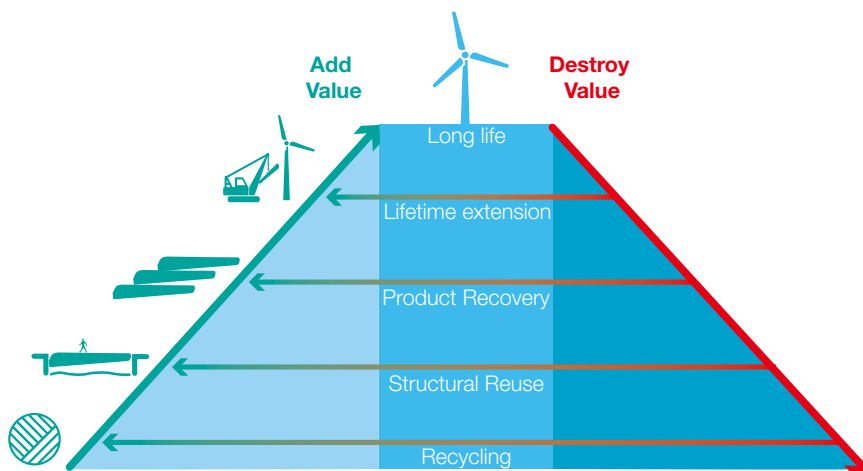

# Circular product design framework

The Circular Product Design framework connects circular strategies to design aspects. Circular strategies describe measures to preserve product or material integrity, i.e., remanufacturing or recycling, and have a strong connection to business models. Design aspects relate to product realisation and provide insights as to how recovery can be anticipated by design intent, such as choices with respect to materials and connections. The framework shows how these are connected.



<b>Conceptual Design</b>	Accessibility		LE	PR		R	A
	Adaptability	LL	LE	PR	SR		B
	Cleanability		LE	PR		R	C
	Dis/re-assembly	LL	LE	PR	SR	R	D
	Ergonomics		LE	PR			E
	Fault Isolation		LE	PR		R	F
	Functional Packaging		LE	PR		R	G
	Malfunction Signalling	LL	LE	PR			H
	Interchangeability		LE	PR	SR	R	I
	Simplification	LL	LE	PR		R	J

# About the design process

Design often moves through a process of concept development, embodiment and detail design. Concept design is about exploring solutions in the first stages of the product development process. Embodiment design entails engineering these initial solutions into the product architecture and defining the product specifications. The detail design stage includes design aspects that facilitate tracing back product information. These stages, concept, embodiment and detail design, constitute the backbone of the design process, and are used here to cluster the design aspects.

The succession of design stages may suggest a straightforward and linear way of working, but design practice is more iterative in nature. Effects of conceptual solutions may only show when embodied and detailed to a sufficient level. Also, a design has to comply to many requirements, and it is often impractical or even impossible to address and optimise these all in one go. Especially when the number of requirements increases by anticipating for recovery activities and taking associated stakeholders wishes into account. This can be solved by developing partial solutions and evaluating their feasibility, thus iterating through the design until a satisfactory product proposal is achieved. The depicted three-step layout is meant to give a foothold for entering the circular design process.



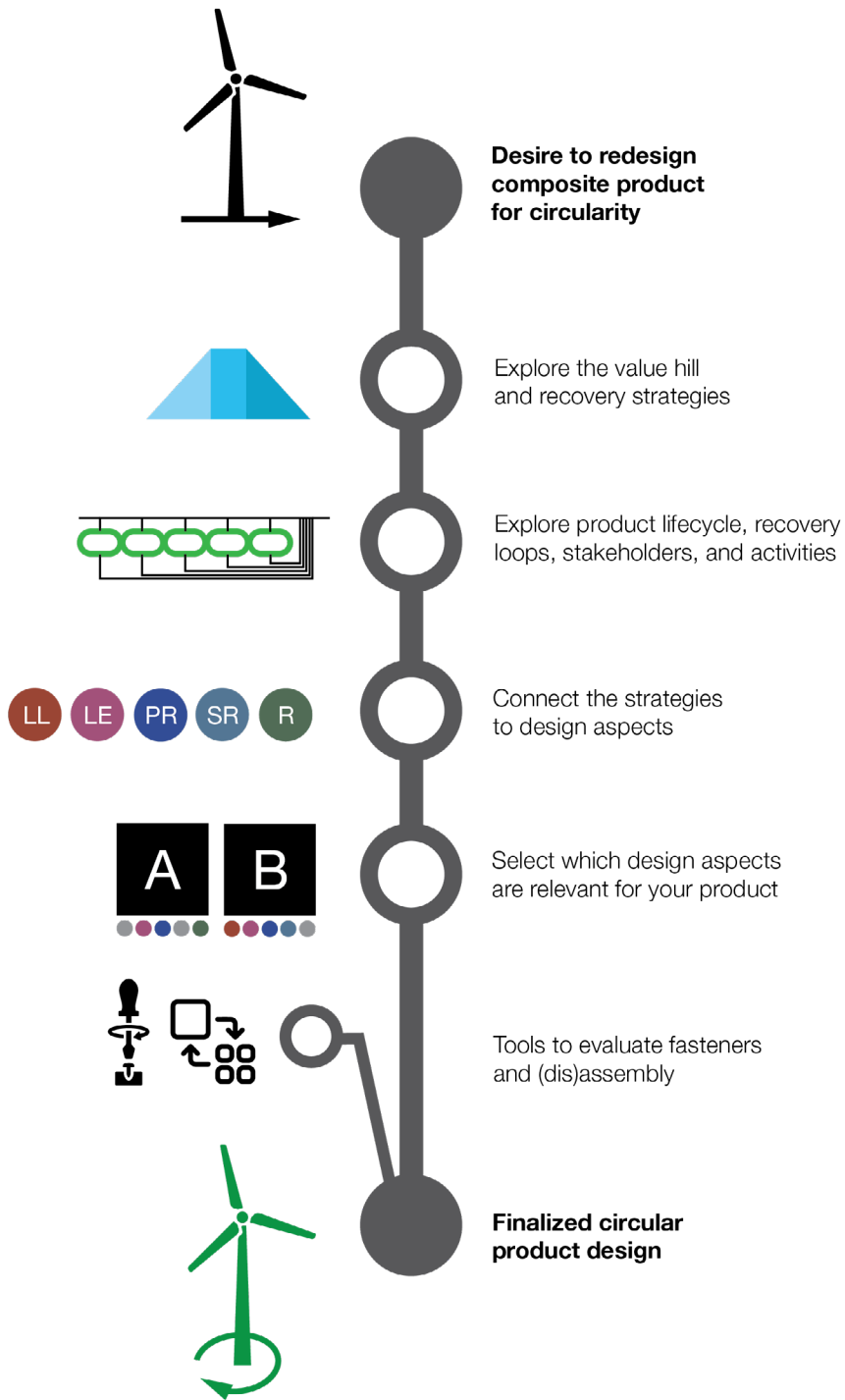



Chapter 2

# Circular Strategies





# Circular Strategies

This section describes five strategies to close the resource loop for composite materials. The strategies are grouped by their aim; preserving product or material integrity. The first group focuses on prolonging the lifetime of products and parts. This involves actions such as reuse, maintenance and refurbishment. Material oriented strategies on the other hand concern retaining material quality, yet finding other applications for it. This involves processes such as repurposing and mechanical recycling. Keeping the product or material as close to its original state as possible, preserving its integrity, is preferred, as this retains the most of the embedded value. That said, it highly depends on the product's use context and associated business models which strategies suit best. The lifecycle exploration sheet, described at page 86, provides a good starting point for evaluating recovery opportunities for the case at hand. This section describes the circular strategies, the following chapter will relate them to design aspects.

Design Aim	Preserving Product Integrity			Preserving Material Integrity	
	Long Life	Lifetime Extension	Product Recovery	Structural Reuse	Material Recycling
Circular economy strategies					
Actions / Processes	Physical Durability Long use Reuse	Repair Maintenance Adapt Upgrade	Refurbishment Remanufacture Parts harvesting	Repurpose Resize Reshape	Remould Mechanical Thermal Chemical

# Long Life



Long life slows the flow of resources through the economic system by extending the lifespan of a product. This is done by designing products that are durable and reliable in use. The goal is to keep the product close to its original state at relatively little cost, thus preserving resources as well as design and manufacturing efforts. Composite materials have good fatigue and corrosion resistance properties, enabling long product life spans. A long lifespan brings additional demands on reliability and safe operation. These factors can be addressed by design. Conventional composite design strategies for safe life, fail-safe and damage tolerance ensure reliable performance, but come at the cost of lifespan (replacement at fixed time intervals), inefficient structural design (redundant load paths) or increased material use (by high safety margins), respectively. Developments in design, engineering, and computation have reduced these safety margins. On the other hand, older products may be over-dimensioned and still be in sound physical condition when rendered obsolete. Thus, these design approaches ensure safe operation of the product, but may conflict with prolonging lifetime or minimising material usage. The gains of incorporating these strategies need to be carefully weighed in the design.

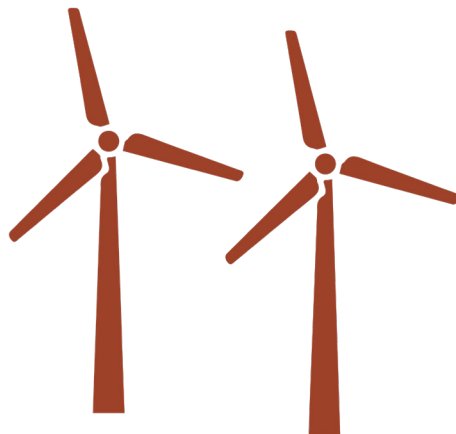

# Lifetime Extension



Lifetime extension concerns all interventions taken during the product lifetime to prolong its use phase. This is done through maintenance, repair, upgrades and adaptations. Maintenance and repair depend on the type of damage and its occurrence, as well as damage growth in the material. Both thermosets as well as thermoplastic composites can be repaired on-site. Many repair techniques and bond patches are available, and their application depends on considerations like time constraints and residual strength. The opportunities for lifetime extension depend on the product design as well as its operational context. Upgrades and adaptations can answer to changes in, e.g., user desires and legislation, which means time becomes an explicit factor in design. Therefore, the use of roadmaps is recommended. Use scenarios that are predefined in the design stage may also serve to estimate degradation and residual quality, and thereby lifetime extension potential at end-of-use. In practice, lifetime extension is considered feasible for composite products, depending on the product state.



# Product Recovery



Product recovery aims to increase the number of use cycles through refurbishment and remanufacturing of products. It also includes harvesting parts to reuse them as spares for lifetime extension measures. These strategies are already applied to various composite products including car and aircraft parts, but also to larger structures like wind turbine blades. For the latter, refurbished blades offer short lead times and choice from a range of models at a reduced cost compared to new models. As with long life and lifetime extension strategies, assessment of the structural state of the material is crucial, yet challenging for composite materials.

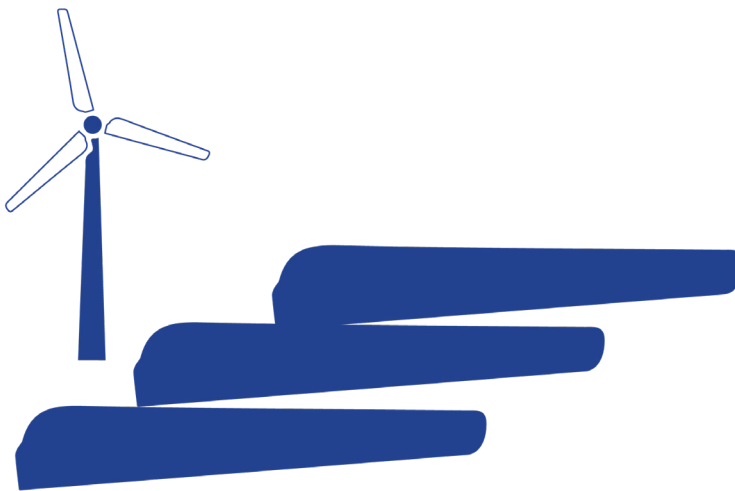

# Structural Reuse



Structural reuse preserves material integrity by reusing the material as-is. Structural reuse takes place through repurposing, resizing, or reshaping the product. These actions discard the original product function, but maintain the unique structural properties, defined by the combination of material composition and structural design. The approach preserves material quality and value with a relatively small investment of energy and resources. Applications of structural reuse have been explored in occasional projects, such as a bridge made of wind turbine blades. The building and construction industry could also reuse these recovered elements, but scalable applications have thus far been challenged by design and materials complexity. It is expected that segmenting large parts into (standardised) construction elements like panels and beams will result in more diverse reuse opportunities.



# Recycling



Recycling returns materials from an end of use situation to reusable raw materials. This connects the end of a product's lifecycle to the start of a new one. In general, a recycling process consists of four steps: first, collecting the materials and, second liberating the materials from the product and breaking them down into processable fragments. Third, sorting the fragments according to their properties and recycling process; and, finally, reprocessing the fragments into reusable raw materials. Reusing the materials in the same type of product is preferred, as this retains the original value of the material. This may not always be possible, and materials can traverse from one product type to another, depending on the properties of the recycled material.

Material recycling options for composites are determined by the matrix material, while most value is found in retrieved fibres. Thermoplastic matrix composites can be remoulded into new products. Thermoset reprocessing is usually based on polymer degradation and aimed at fibre recovery, using mechanical, thermal or chemical processes. Composites are inherently complex materials: there are few standardised composite formulations, and often additional materials are used like core materials, adhesives, and metal inserts, which complicates reprocessing into reusable raw material. Generic recycling problems apply for collection, identification, separation, and sorting of the material and contamination in the reprocessing stage.





Chapter 3

# Design Aspects





# About the design aspects

This section outlines 26 design aspects that can be used in the design of composite products. Each design aspect relates to one or several of the circular strategies discussed in the previous section. The relevant circular strategies for each design aspect are shown by the colored circles at the top of the page.

In this section you will find a brief explanation for each design aspect, as well as some design guidelines that can be followed to incorporate a given aspect into your design. Examples are also shown, which have been taken from industry or student-led projects.

The design aspects are grouped by design stage in which they might be most relevant: concept design, embodiment design, and detail design. Each design aspect is assigned a letter from A to Z.

The value hill should be considered while selecting design aspects to incorporate into a given design. The higher-value circular strategies are preferred (long life, lifetime extension) over the lower-value strategies. While not all strategies might be relevant for a given product, all circular strategies should be considered in the design process.

Finally, it should be noted that these design aspects are often context-dependent. Without properly considering context, one might observe some contradictions in the design aspects - for example between function integration and interchangeability. It is ultimately up to the designer to take context and common sense into consideration when designing, considering all stakeholders involved across the life of a product. In general, these design aspects can be considered a starting point or tool to engage critically with circular product design of composite products.



		LL	LE	PR	SR	R	
<b>Conceptual Design</b>	Accessibility		█	█		█	A
	Adaptability	█	█	█	█		B
	Cleanability	█	█	█		█	C
	Dis/re-assembly	█	█	█	█	█	D
	Ergonomics	█	█	█			E
	Fault Isolation	█	█	█		█	F
	Functional Packaging		█	█		█	G
	Malfunction Signalling	█	█	█			H
	Interchangeability		█	█	█	█	I
	Simplification	█	█	█		█	J
<b>Embodiment Design</b>	Connection Selection	█	█	█	█	█	K
	Function Integration	█	█		█	█	L
	Material Selection	█	█	█	█	█	M
	Keying		█	█			N
	Modularity	█	█	█	█	█	O
	Manufacturing Process		█	█		█	P
	Redundancy	█	█	█			Q
	Sacrificial Elements	█	█	█		█	R
	Structural Design	█	█	█	█	█	S
	Surface Treatments	█	█	█	█	█	T
<b>Detailed Design</b>	Documentation		█	█	█	█	U
	Identification		█	█	█	█	V
	Monitoring	█	█	█	█		W
	Standardization		█	█	█	█	X
	Timing and Planning		█	█		█	Y
	Circular Storytelling		█	█		█	Z

# Concept Design Phase

Circular economy strategies add extra reuse and recovery activities to the product's lifecycle. These strategies, activities and associated stakeholders can be mapped out using the product lifecycle exploration sheet. The design can then be tailored to facilitate the selected recovery activities. For example, making internal components accessible to facilitate repairs. The concept stage is a good time to think about such solutions, as it brings together product features that have to be embodied and detailed later. As such, the concept design sets the stage for further embodiment of the product.

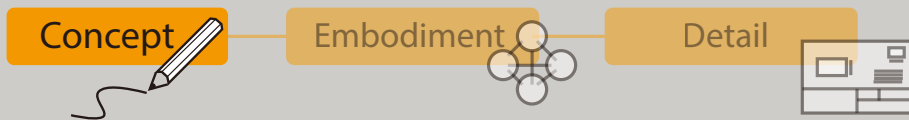

# Concept Design



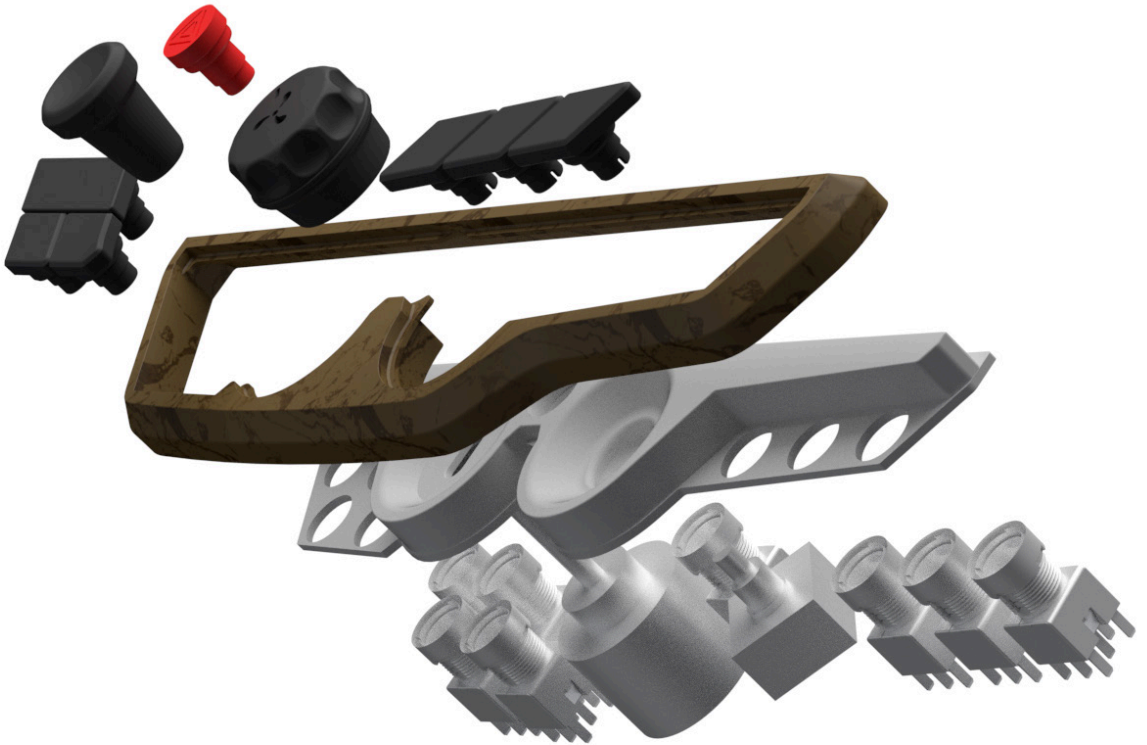

**DEMONSTRATOR EXAMPLE//MICROCAB**

In this example from Microcab, we can see how the switch-pack front cover is easy to dismantle, exposing the internal components for servicing if needed.

# Accessibility

A



## DESCRIPTION//

Accessibility refers to ensuring internal parts, materials, and connections can be easily accessed or removed. In doing so, it becomes easier to repair or replace components, as well as separate and sort constituent parts at a product's end-of-life.

## DESIGN GUIDELINES//

- Grouping parts and/or materials in modules is an effective way to enable access to various sub-assemblies of a product
- Design should aim to allow access from a single side, using a single tool
- Connections and fasteners should be selected that are easily identifiable and removable

## DESIGN TOOLS//

- Platform design: design using a common base, the platform, on which the product is built and configured to specification.
- Disassembly map: can be used to improve disassembly of a product and thus accessibility to components.

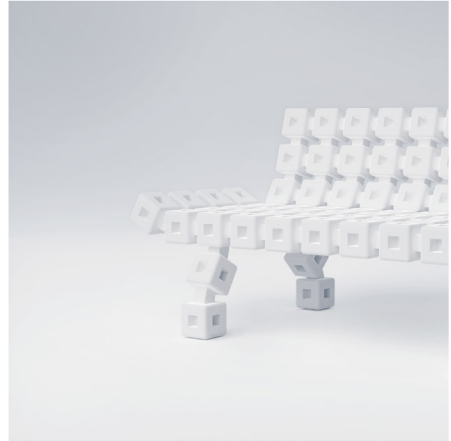

### **DEMONSTRATOR EXAMPLE//UNITO**

The unito system architecture is built from CO2 storing blocks that are connected with different angled connectors. The system was designed to build furniture pieces that can be adapted and reconfigured by users to meet different needs.

# Adaptability

B



## DESCRIPTION//

Adaptability refers to anticipating and enabling changes and adjustments that might be made to the product during its successive use cycles. This serves to improve the product's relevance in the future and avoid obsolescence.

## DESIGN GUIDELINES//

- Creating multi-functional designs allows for a specific product to be adapted to a variety of uses
- Facilitating DIY solutions and adaptations makes it easier for a product to be adapted to a use that is outside of the original design intention.
- Design for versatile, customisable layout of a product components.
- Designs that allow for changeable surface color can be adapted to new user tastes, prolonging emotional utility.
- Transformable system, and reversible assembly, allows for component changes that can enable adaptability to different uses.





**DEMONSTRATOR EXAMPLE//MAIER**

MAIER treated the front side of the dashboard fascia with a smooth, high quality coating, which is resistant to the chemicals it might endure whilst in use.

# Cleanability

C



## DESCRIPTION//

Cleanability is all about designing products, parts, and surfaces so that they can be cleaned easily, or so that they prevent the accumulation of dirt. Often times, dirt impedes proper functionality, and by ensuring components can be cleaned, the product lifespan can be improved.

## DESIGN GUIDELINES//

- Smooth surfaces help a product cleanability as they make it easy to wipe off any accumulated dirt or grime.
- Accessible and demountable parts & modules, especially where dirt accumulates, are preferred.
- Cleanability is improved by designing a product to be fully cleaned using the same cleaning method, and designing all materials & surfaces to withstand the same chemicals



### **DEMONSTRATOR EXAMPLE//CONENOR**

These pavillions are assembled using stainless steel screws and bolted joints, the demonstrators are temporarily placed structures that must be disassembled later.

# Dis/re-assembly

D



## DESCRIPTION//

Dis-and-reassembly is about designing product that facilitate manual or mechanical disassembly and reassembly. Products designed in such a way allow for reuse or replacement of parts, which improves product longevity as well as the recovery rate.

## DESIGN GUIDELINES//

- Using reversible connections (e.g. screws), and avoiding in-moulded inserts
- Mechanical assembly systems (e.g., form fits)
- Optimised and short component disassembly paths
- Use commonly available, standard, accessible tools, and connections.

## DESIGN TOOLS//

- Fastener finder
- Disassembly map

# SOFAIR, SO GOOD

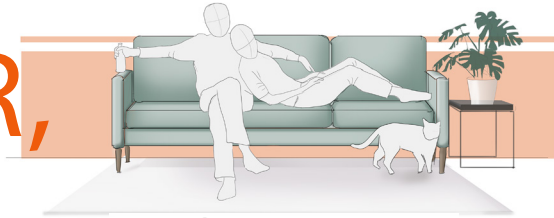

Nina van der Klauw, in opdracht van CPD Research Group

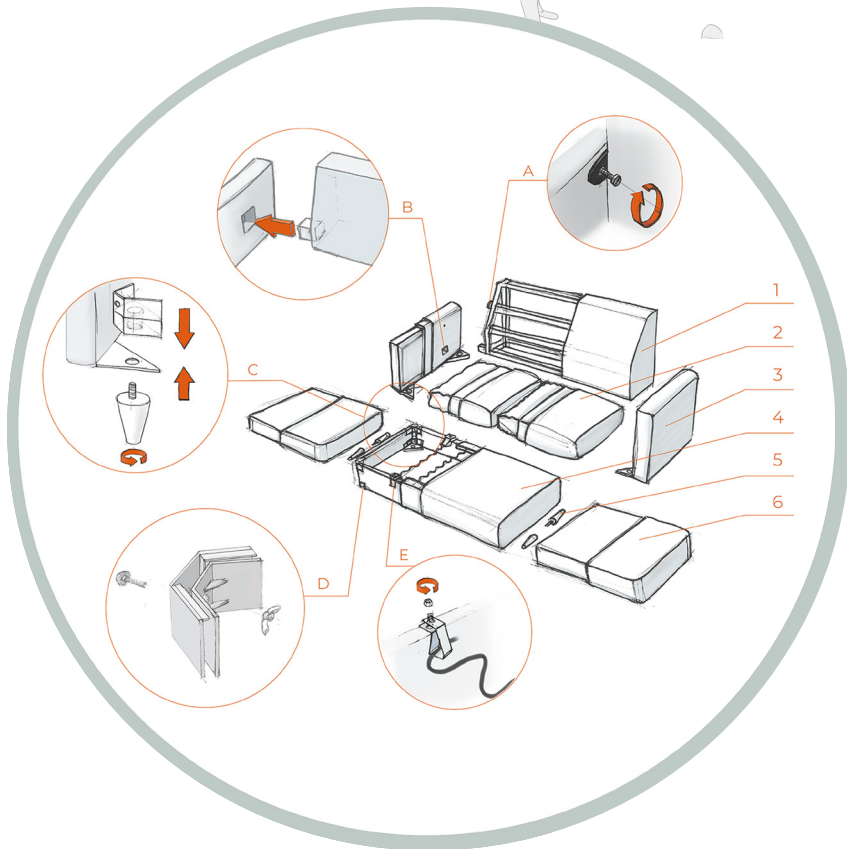
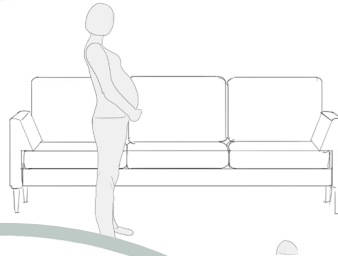

## DEMONSTRATOR EXAMPLE//SOFAIR SO GOOD

The sofa's main elements are easy to detach and reconfigure without damaging the materials. Moreover, the configuration can be adapted to ensure the user keeps an ergonomic seat for life. Increase your seating comfort by letting sofair grow with you!



## DESCRIPTION//

Ergonomics refers to designing products can be used, maintained, reworked, and reprocessed in a safe and efficient way. By making these circular processes safe and efficient, the likelihood of their undertaking is increased. If a circular strategy cannot be undertaken in a safe way, it is likely that lower-value recovery strategies like energy recovery would be conducted instead.

## DESIGN GUIDELINES//

- Product should be ergonomically designed for use, as an ergonomic product is likely to be used for longer.
- Design should consider the human actions taken to undertake the strategies of lifetime extension and product recovery.
- This typical involves dis/re-assembly and designing accessible components and connections.

# EcoJoint

REPLACEABLE WOOD CONNECTION FOR PARTICLEBOARD

CPD research group  
COEN AMELN

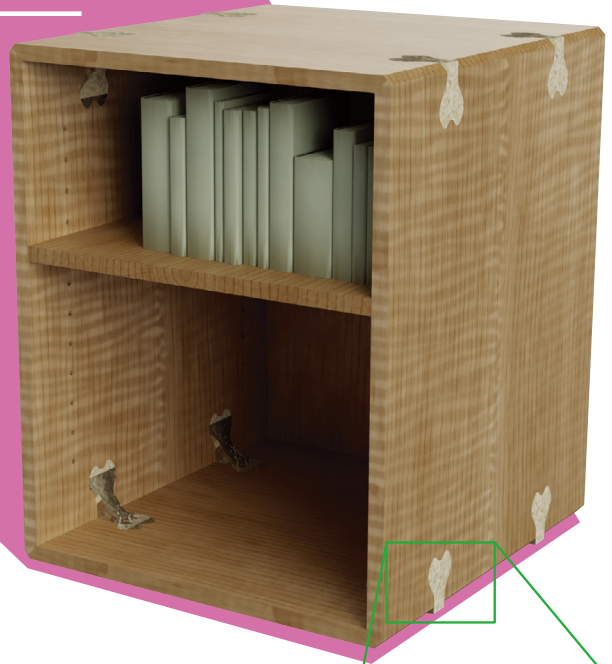

the classic cam-lock connection does irreparable damage



Reusable



COMPOSTable



reusable

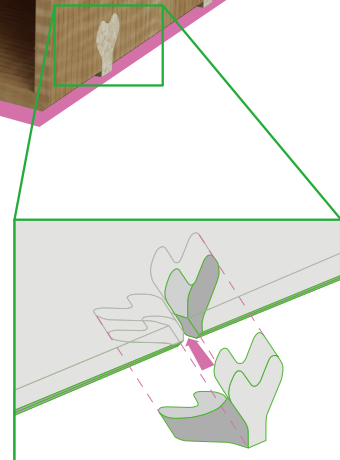

Easy to (dis-)assemble without tooling

## DEMONSTRATOR EXAMPLE//ECOJOINT

The cabinet is designed such that mechanical failure will most likely occur within the joints rather than in the panels. The Eco-joint connection is made of an endlessly recyclable material and designed to fail before the particle board does. In this way, the particle board will not end up in landfill and the connection can be replaced easily and sustainably.

# Fault isolation

F



## DESCRIPTION//

When something goes wrong in a product it is important to understand where the fault is occurring. Fault isolation refers to designs which better enable tracking of a fault to its cause, for example a worn component. This approach enables quick and easy repair, increasing the overall product lifespan. A practical example of fault isolation is the Diagnostic Trouble Codes (DTC) inside a car that mechanics use to isolate and fix specific problems across the vehicle.

## DESIGN GUIDELINES//

- By developing and promoting repair diagnostics, manufacturers ensure their products are easier to repair.
- Designs should make approaching failure noticeable for users or service inspections, which enables component replacement. This may prevent more severe effects from occurring due to component failure during use.

F



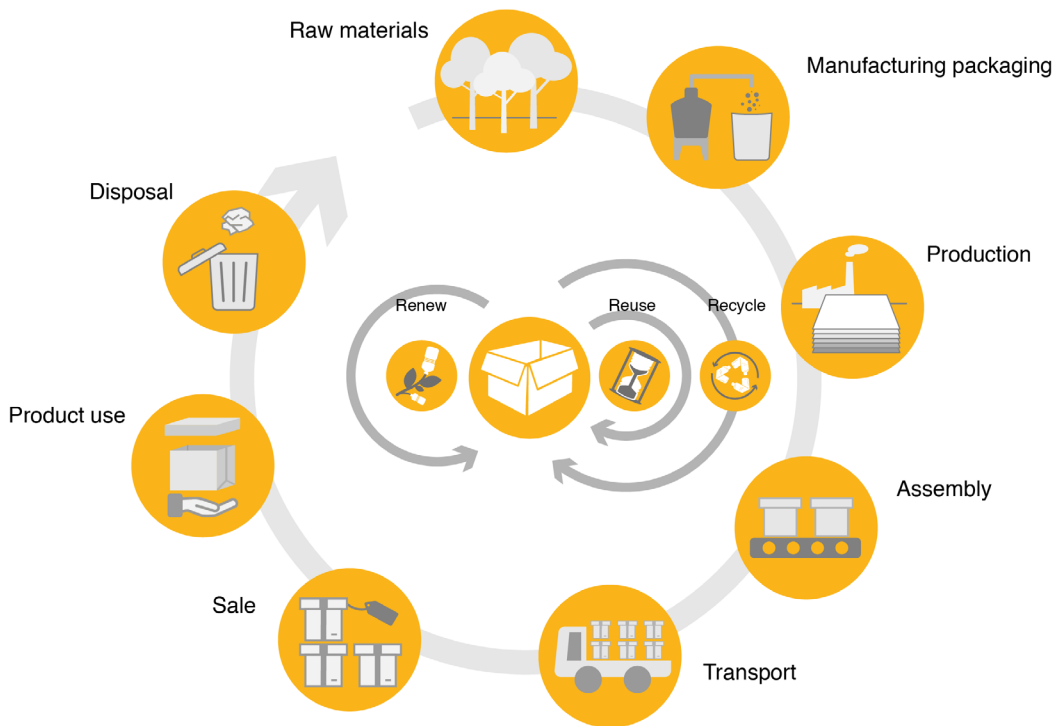

### STRATEGY EXAMPLE//CIRCULAR PACKAGING

Four strategies that apply to the design and implementation of packaging for a circular economy are rethinking the need for packaging, reusing packaging, using renewable resources in packaging, and finally recycling existing packaging.

# Functional Packaging

G



## DESCRIPTION//

Packaging of products can generate a lot of waste. By choosing packaging for a product or component to optimize transport and distribution while minimizing material use, it is possible to make overall sustainability gains in the product life. This could include a number of approaches, based on the product and its specifications.

## DESIGN GUIDELINES//

- Reducing packaging weight and volume enables sustainability gains in the transportation phase, as well as cutting down on single-use materials.
- Improving stackability and handling enables optimized transportation of products, which can result in fewer loads for a given quantity of goods.
- Ensuring product/component protection is critical, as a damaged component that must be discarded might have a much larger net impact on sustainability than the packaging put in place to protect it. Here, care should be taken in balancing the likelihood of product/component damage occurring with the packaging solution being considered.

G



#### **PRACTICAL EXAMPLE//MALFUNCTION SIGNALING**

The check engine light, replace oil light, and battery light are all examples of malfunction signaling from the onboard sensor system in a typical car.

# Malfunction Signaling

H



## DESCRIPTION//

Malfunction signaling is about designing products that indicate when they are about to fail. This facilitates the inspection of products and subsequent actions such as repair or replacement of components, before failure actually occurs. By making this process easier, the overall product lifespan can be improved. A practical example of this is the check-engine light in a vehicle, which signals when a problem in the engine should be addressed.

## DESIGN GUIDELINES//

- Indicating elements should be designed to signal when a product is worn and/or close to failure. Examples could range from wear strips to electronic indicators
- Components that are prone to failure should be designed such that they can be monitored in a selected way. This could be through visual inspection or by electronic means.
- Accessible parts also goes hand-in-hand with malfunction signaling, as they are easier to inspect for wear

H



#### DEMONSTRATOR EXAMPLE//CONENOR

The planks are replaceable if damaged by virtue of removable fasteners and standard range of construction material dimensions.

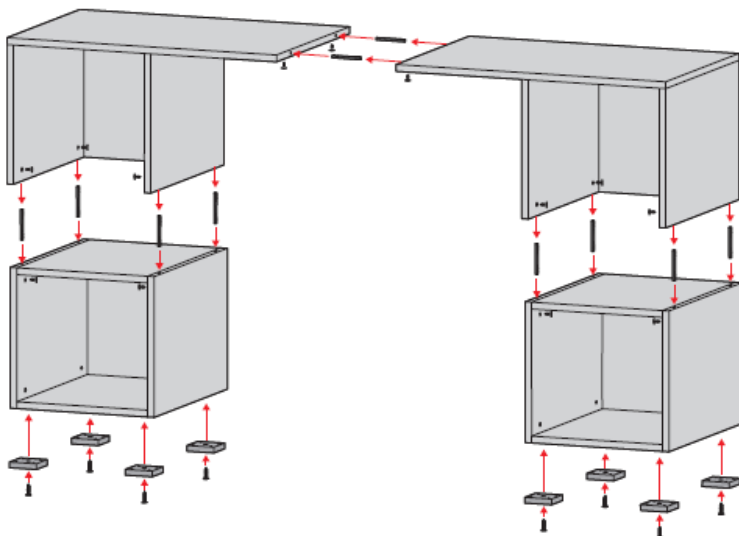

#### DEMONSTRATOR EXAMPLE//MORETTI

Individual, standard sized panels can be replaced and exchanged between furniture pieces.

# Interchangeability

I



## DESCRIPTION//

Interchangeability refers to designing products that have replaceable or exchangeable sub-assemblies. This design approach can have a number of benefits to repairability, product re-purposing, and lifetime extension, as well as structural reuse and recycling. Typically, when a product fails, the problem can be traced to a specific component, while the overall product might contain parts that are still functional.

## DESIGN GUIDELINES//

- Interfaces should be designed that allow for the exchange of parts
- Matching dimensions and functions of parts and replacements
- Standard, accessible and dismountable parts, modules, and connections allows for interchangeability of components.



**DEMONSTRATOR EXAMPLE//MORETTI**

Using simple shapes and colours is expected to reduce the sensitivity to fashion changes.

# Simplification

J



## DESCRIPTION//

Simplification refers to designs that minimize the complexity of the product in terms of functionality, appearance, assembly, and materials composition. This approach can have a number of benefits. From a functional and use perspective, simple products are easier to use, tend to be more timeless, and are resilient against changes in trends. From a technical perspective, simplification improves repairability, separation and recovery of materials at end-of-life.

## DESIGN GUIDELINES//

- The simplest design option available should be selected.
- Within a design, reducing the number of material types, components, and assembly steps improves product simplicity.



# Embodiment Design

Embodiment design entails engineering concept solutions into the product architecture. This means constructing the product layout; how the product and its subassemblies are built and interconnected. All circular economy strategies are associated with modular approaches, which can be enhanced by careful selection of connections and keying features. Integrating functions and multiple components into a single optimised part is one of the main potential benefits of using composite materials. The level of integration has to be carefully considered based on the prospective product use cycles. These design aspects construct a product architecture of which the part properties need to be further specified.

Embodiment design also includes defining the product specifications. This requires selection of the manufacturing process, surface treatments and materials, as well as developing the structural design. With the specifications known, the design is ready to proceed to the final stage: detailing



# Embodiment Design



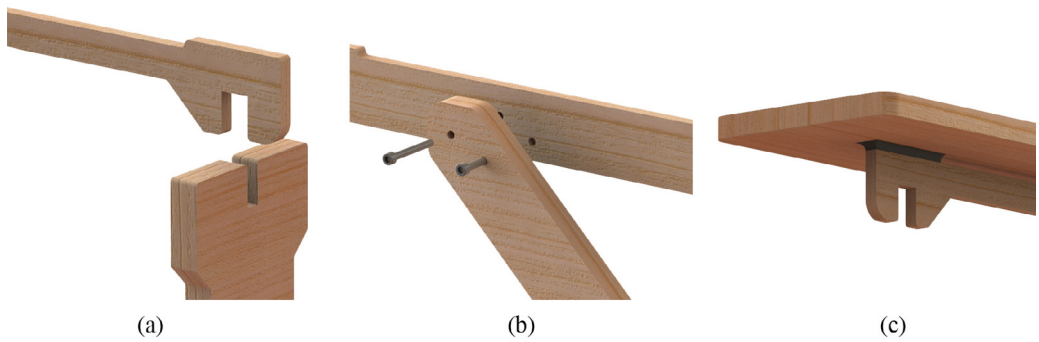

### DEMONSTRATOR EXAMPLE/WTB PICNIC TABLE

No one single connection type is the best for all cases. The wind turbine blade table used slotted fits (a) to ease (dis)assembly, fasteners (b) to absorb thickness tolerances on mated parts and adhesive bonds (c) to prevent water ingress.

# Connection Selection

K



## DESCRIPTION//

Connection selection refers to selecting connections that can be accessed, opened, and reused where appropriate. This approach facilitates use, rework, and recovery actions during product life. If a disconnection process is not possible, many of the circular strategies outlined in this guide become impossible or much more difficult to achieve.

## DESIGN GUIDELINES//

- Reversibility of connectors is preferred. This includes screws, clips and several types of snap-fits. Chemical connections such as glues or bonding agents are often irreversible.
- Recovery action should be considered when selecting a connection type. This includes the operator (e.g. user or service personnel) and the tool types that need to be available.
- Material compatibility and use resistance (e.g., wear and aging) should also be considered when selection a connection type.

## DESIGN TOOLS//

- Fastener finder



#### **DEMONSTRATOR EXAMPLE//MAIER**

The maier demonstrator integrates fastening clips into the dashboard fascia cover. This approach minimizes the need for additional fasteners, facilitating material recovery.

# Function integration

L



## DESCRIPTION//

Function integration refers to the design of components which combine multiple functions and subcomponents into one part. This approach simplifies the repairing and disassembly process of the product. In addition, by combining multiple functionalities into a single component made of a single material, the recovery process is facilitated by avoiding the use of multiple materials. This design aspect is context dependent, and should be balanced against interchangeability. For example, if a specific functional component undergoes extensive wear during use, it makes sense to keep it separate and interchangeable as opposed to integrating it as part of a larger component structure.

## DESIGN GUIDELINES//

- Function integration can be done by integrating connectors with parts, for example using clips, snap-fits, etc..
- Design can combine structural functions with other functions such as aesthetic or aerodynamic features.
- Balance function integration with interchangeability in a context-dependent design approach.

L



**DEMONSTRATOR EXAMPLE//CRF**

The CRF demonstrators made extensive research into the incorporation of recycled or biobased materials into their composite blends.



## DESCRIPTION//

Material selection refers to the selection of matrix, reinforcement, connections, and other materials to perform optimally for both the use phase and recovery phase of the product. For composites, this includes the type and orientation of reinforcements. This approach is important to ensure a product endures for its specified lifespan and materials can be recovered at the product end-of-life.

## DESIGN GUIDELINES//

- Material choice should consider reprocessing compatibility, by using chemically similar matrix & reinforcement (self-reinforced composites), avoiding mix of biological and technical materials, or other means.
- Using recycled and recyclable materials. This could be thermoplastic or reversible thermoset matrices and short fibres, and limit the number of materials used within an assembly to promote recyclability.
- The effect of aging (e.g., discolouring & loss of quality) should be considered when selecting a material.
- Material selection should be done such that the product can cope with hostile conditions, prolonging lifetime.
- Hazardous chemicals with negative environmental impacts should be avoided





**DEMONSTRATOR EXAMPLE//CRF**

Alignment pins at the bottom assist mounting of the part, the overall shape makes that it can only be positioned in one way (poka yoke).

# Keying

---

N



## DESCRIPTION//

Keying is about using the product shape to facilitate the alignment of components. By doing so, the product dis-and-reassembly is facilitated, leading to benefits in repairing or removing components from a product.

## DESIGN GUIDELINES//

- Keying can be done by using pins, grooves, and other mating shapes for aligning and placing components together.
- Keying features can be integrated directly into the design of a component, and goes hand-in-hand with function integration.

N

# VIANOVA INTERIOR COMPONENTS LIFE CYCLE

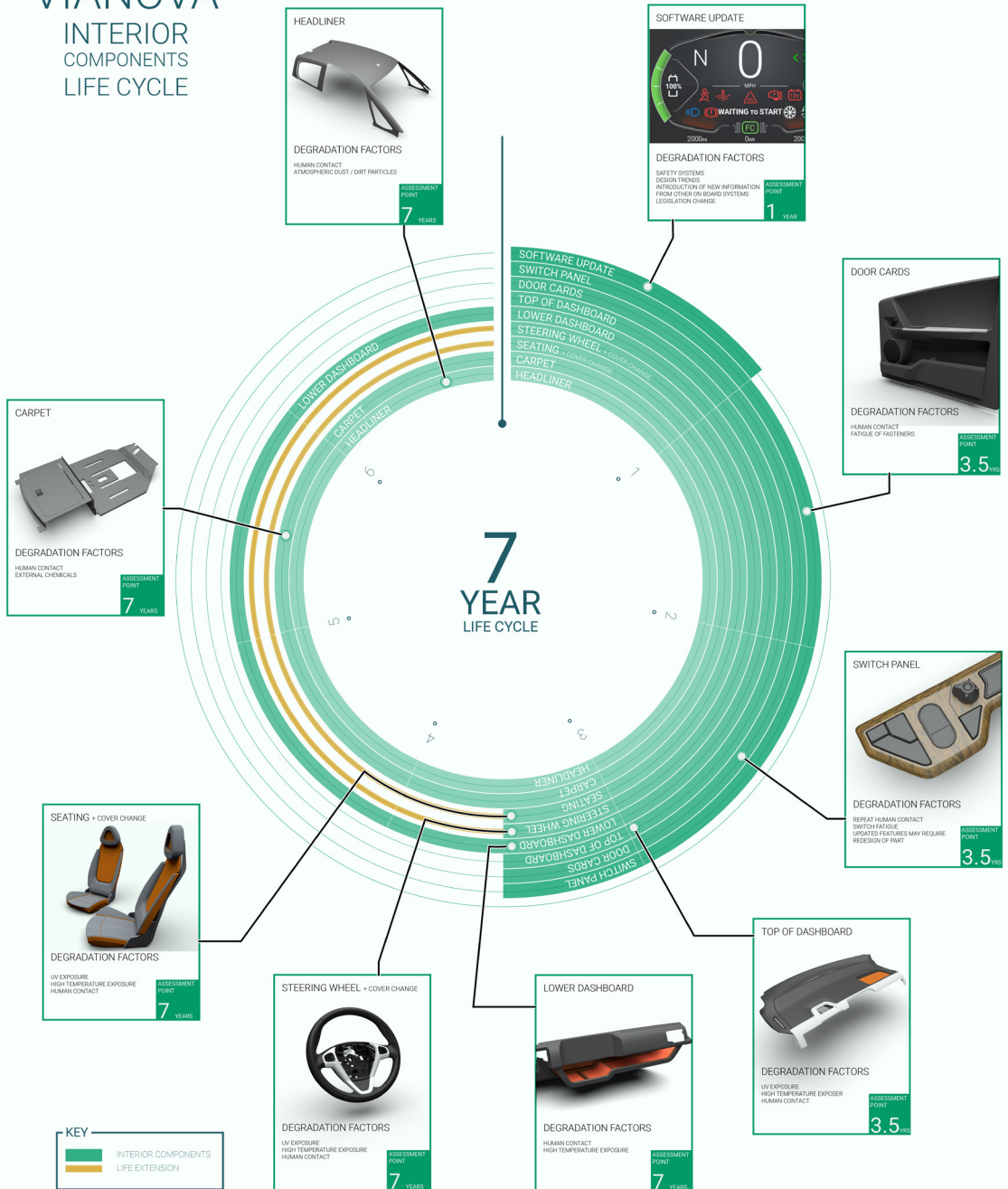

## DEMONSTRATOR EXAMPLE//MICROCAB

The grouping of materials and parts is one of microcab's key drivers in the design. The module composition is governed by the type of exposure & materials used, in order to achieve components of equal lifetime and thereby service intervals.

# Modularity

---

O



## DESCRIPTION//

Modularity refers to designs in which features are grouped within the product to create sub-assemblies that are accessible, removable, and interchangeable. This approach leads to benefits for disassembly, repairability, and recovery of product parts at end-of-life.

## DESIGN GUIDELINES//

- Grouping in modules could be done by matching lifetime or maintenance intervals of components. This facilitates maintenance and repair.
- Module grouping could consider chemically similar materials, or the isolation of hazardous substances, to facilitate material recovery at end-of-life.
- Modularity can also allow for (functional) customisation and adaptation of a product.

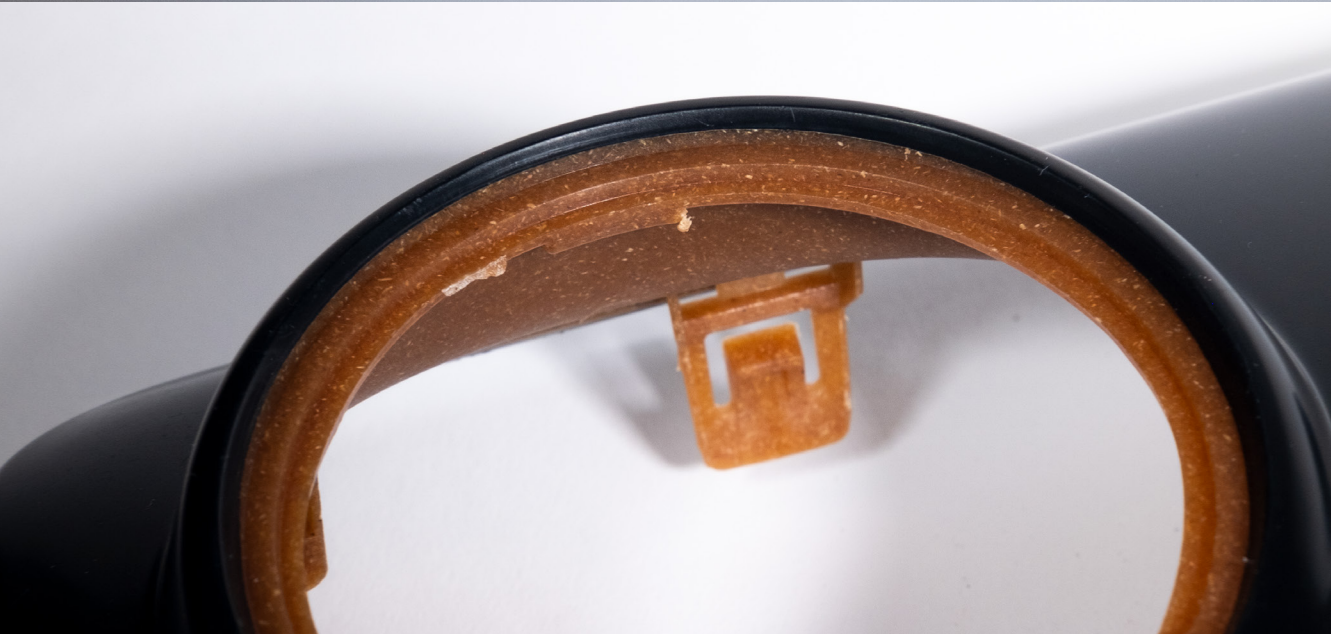

#### DEMONSTRATOR EXAMPLE//MAIER

2K injection molding allows to increase the use of recycled materials. Virgin materials on the front, where a high level of aesthetic finishing is needed, and recycled material on the back. The process of 2k injection moulding requires compatible materials.

# Manufacturing Process

P



## DESCRIPTION//

Proper selection of the manufacturing process is important to minimize emissions and meet the material, functional, shape, and recovery criteria for a given product. The manufacturing process can have implications on a number of other design aspects which are important to consider for circularity, including reparability, and material recovery.

## DESIGN GUIDELINES//

- Design should optimise fibre architecture. Automated manufacturing can be used to achieve consistency.
- Reducing waste & emissions from the manufacturing process is important; consumables (foils, tapes, etc.) and material offcuts, especially when impregnated with resin, should be avoided.
- Specific manufacturing processes allow for a greater degree of recycled content uptake.
- Use of commonly available processes, standards, tools, and connections is preferred.

P



### **PRACTICAL EXAMPLE//CLIMBING ANCHOR**

In rock climbing, when setting an anchor, it is always necessary to ensure some form of redundancy in the load path, in case one might fail. The same principle can be applied to the design of products to increase their lifespan.

# Redundancy

Q



## DESCRIPTION//

Redundancy is about adding additional materials or functionality to ensure continued operation and safety of a product, even after parts partially degrade or are removed. This approach leads to an improved product lifespan.

## DESIGN GUIDELINES//

- Redundancy can be included by adding extra material on wearing areas
- Integrating multiple redundant load paths can increase redundancy.
- Adding excess functionality is also a means to increase redundancy from a use perspective.

Q





**DEMONSTRATOR EXAMPLE//MICROCAB**

The switchpack housing protects internal, non-circular, parts to prolong their lifetime. The housing itself will be replaced in 7-year refurbishment intervals.

# Sacrificial Elements

R



## DESCRIPTION//

Sacrificial elements are replaceable components and surface treatments included in a design that take on wear and damage, in order to protect other components. By providing specialized replaceable parts to take on wear, the integrity of the entire product is improved, increasing the product lifespan. A practical example of this is the bumper of a car, which is designed to absorb impact and be easily replaced if damaged.

## DESIGN GUIDELINES//

- The first step to including sacrificial elements is to identify the areas subject to high levels of wear or degradation.
- These areas can be protected by applying protective surface treatments, such as paints or coatings.
- Another approach is to apply protective elements, for example covers, caps, or parts that are designed to be impact-resistant.

R

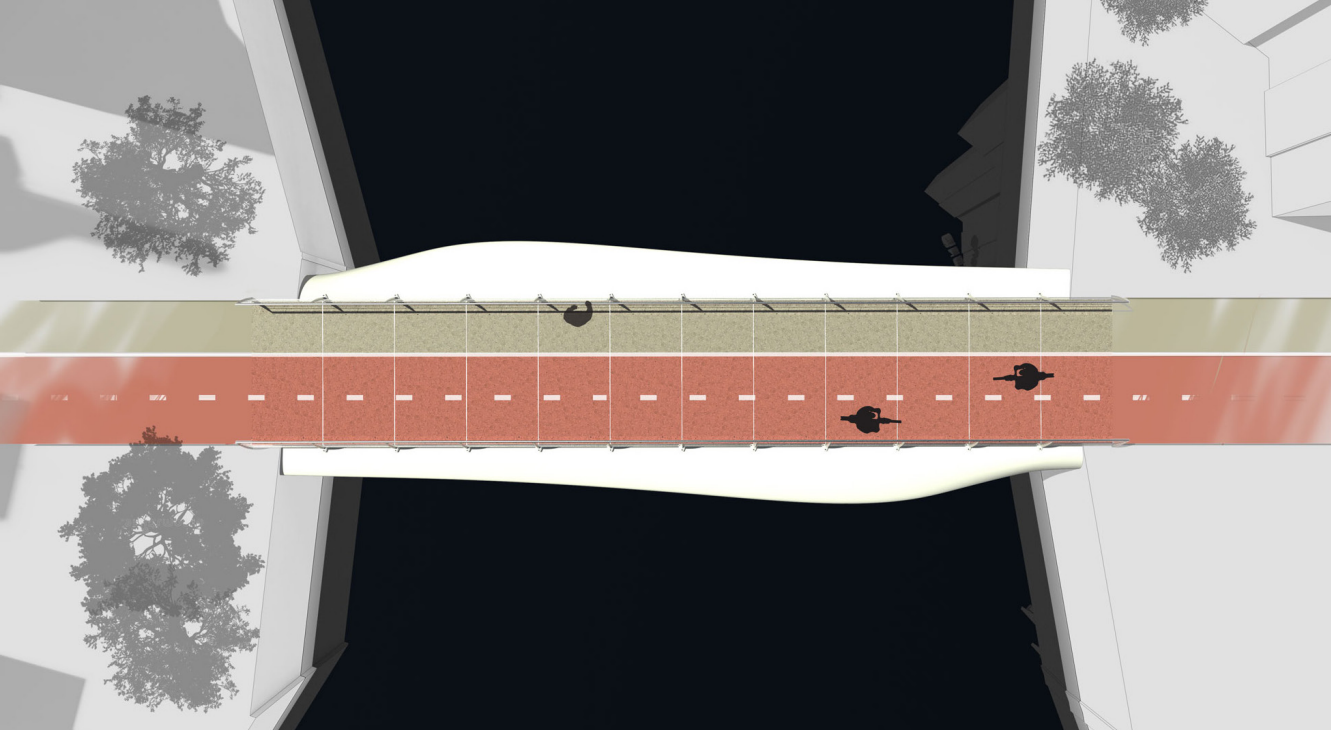
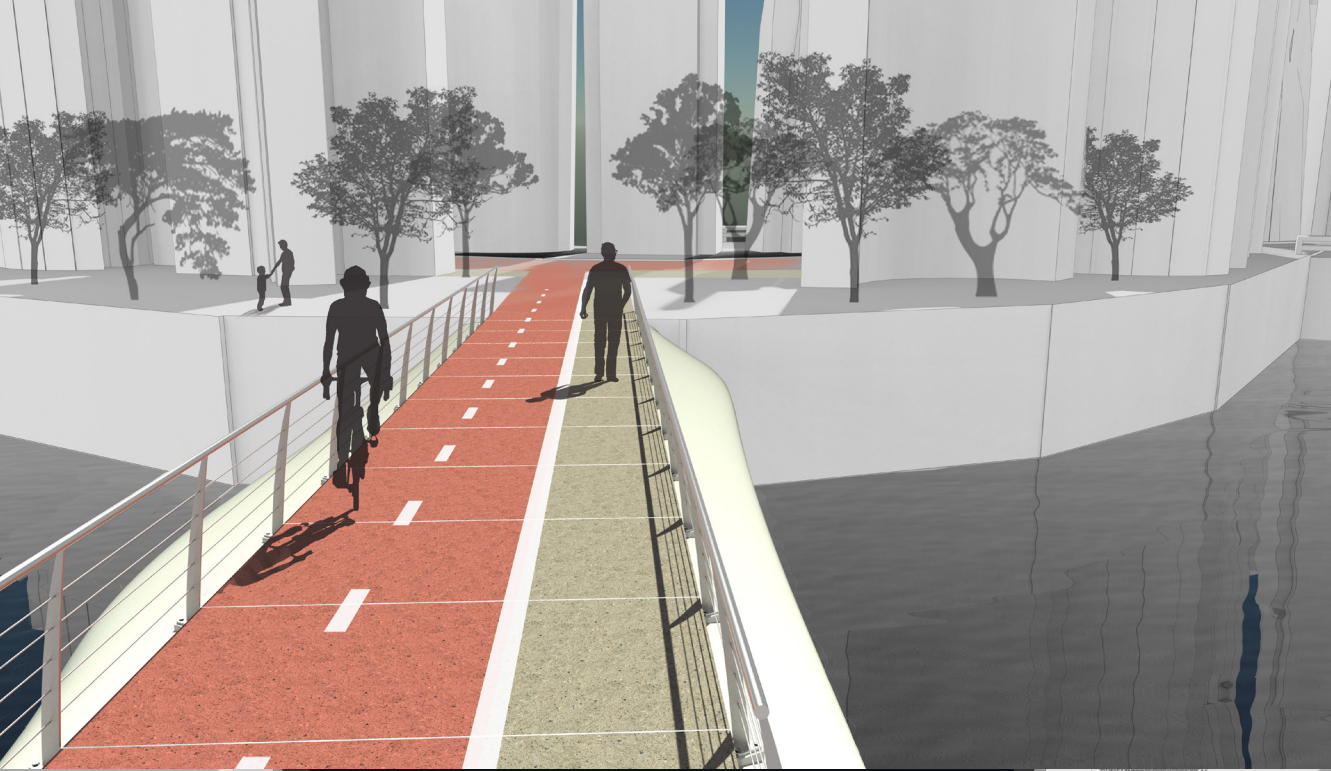

### **DEMONSTRATOR EXAMPLE//BRIDGE OF BLADES**

This bridge repurposes two wind turbine blades, leveraging the structural stiffness and strength of the original design.

# Structural Design

S



## DESCRIPTION//

Structural design means optimizing the material structure, shape, and product architecture of a product or component to ensure the desired structural performance. This is important to avoid any potential component or product failures which would reduce the lifespan of a product. Properly designed structural components also improve reparability and recovery of non-structural parts, as well as offering potential for structural reuse.

## DESIGN GUIDELINES//

- Form stiffness and load bearing shapes should be used in the design of structural components
- Integration of form and material placement can help meet load cases.
- Reusable structural elements are preferable.
- Allow for recycled content uptake in structural elements.
- Use commonly available, standard, accessible tools, and connections in the process.

S



#### **DEMONSTRATOR EXAMPLE//MICROCAB**

In the microcab demonstrator, a decision was made to not add a surface treatment, and instead to keep the base material visible. Sometimes, the best solution is to apply no coating at all.

# Surface Treatments

---

T



## DESCRIPTION//

Surface treatments refers to the selection of coatings and other surface treatments such that they are appropriate for use, reuse, and reprocessing of the product and its materials. Surface treatments of materials are often used to prevent material degradation, which is useful to extend the lifespan of a component or product. However, surface treatments can have an impact on how easy it is to recover or recycle certain materials. As such, a balance must be achieved between the desire to extend the lifespan of a material and the potential for its recovery at its end-of-life.

## DESIGN GUIDELINES//

- Protective gel-coats, paints, tapes, foils, or other treatments are useful to prevent material degradation of components by UV radiation, moisture, or erosion.
- In general, non-hazardous substances should be used to support rework and reprocessing.
- Materials, including surface treatments, should be selected for compatibility with the recycling process

T

# Detail Design Phase

The detail design stage includes design aspects that facilitate tracing back product information. To facilitate recovery, the product has to be identifiable, and its initial specifications should be laid down in appropriate documentation. Documentation of the product specifications and instructions—and making these available to the designated stakeholders—serves to solve the information gap that hampers many recovery processes in practice. These design aspects support the availability of product information, which is key for efficient recovery actions and effective value retrieval.

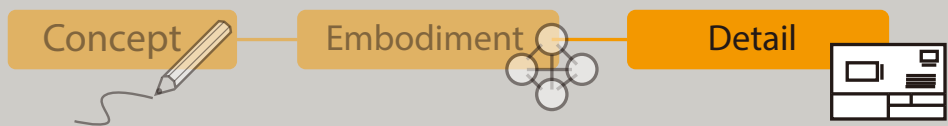

# Detail Design







**ECOBULK** End Users & Stakeholders Platform

Label Scanner My Products Products Marketplace Profile Logout

End User Test

Product	Manufacturer	Description
Cube unit	Moretti	Basic cube unit for modular furniture



This cube unit can be used on its own as a chair, or combined with others to make a table or a bookshelf.

[Answer Survey](#)

Quantity:

[Request Purchase](#)

[Request Leasing](#)

**General information**

Product name	Cube unit
Manufacturer	Moretti
Product code	D2S6V3
Unit cost (new)	35 €

### DEMONSTRATOR EXAMPLE//MATERIAL PASSPORT / ECOBULK PLATFORM

A material passport aims to keep track of necessary data over the prolonged use phase. By assigning the required information to the product, the job of repurposing designers and engineers becomes easier in analysing the decommissioned product and treating it with the application process.



## DESCRIPTION//

Documentation is about providing information about the product, components, and functions to stakeholders in the value chain, as well as actors in the product and component life cycles. With this information, it becomes easier for stakeholders to make assessments on repairability, reuse, or material recovery at end-of-life.

## DESIGN GUIDELINES//

- The process of documentation starts by identifying which information the actors need, and how they might get it.
- Documentation should include design specifications: dimensions, assembly, part id's, material composition, and any other relevant information.
- Service manuals and repair tutorials are useful to ease repairability.
- Certification and standards can also be used as documentation where available.
- Material passports can be used to lay down the specific composition of components, including the matrix, reinforcements and other details such as integrated fasteners.



#### **DEMONSTRATOR EXAMPLE//CONENOR + MAIER**

Ecobulk demonstrator products are equipped with a QR code which links to an end user database. The database contains information on the product's composition, design and end of use treatment options. The Maier demonstrators contain identification codes stamped on the inside of the parts.

# Identification

V



## DESCRIPTION//

Identification refers to using labels, tags, or other means to facilitate recognition of the product, part, materials, or specifications. This is an easy action that can facilitate, reuse, repair, and material recovery. Identification relates closely to documentation.

## DESIGN GUIDELINES//

- Labeling products & components should be done to allow for their identification. Some materials are otherwise difficult or impossible to decipher from one another.
- One method of identification is to define specific material characteristics that are used in separation processes. As such, considering separation processes during the identification phase is useful. Separation processes might include IR scanning, density float separation, etc.
- Placing material markings on parts is another common way of identifying materials.
- Mixing in markers into the materials can also be done as a means of identification.

V



## **PRACTICAL EXAMPLE//DIFFERENT SENSORS**

Monitoring can take a wide variety of forms but usually involves data acquisition and subsequent analysis to check for any potential issues.



## DESCRIPTION//

Monitoring refers to determining and logging product properties and use conditions over the product lifetime. By doing so, it becomes easier to know when a specific component or product might need maintenance or repair before failure will occur. This can also be used to extend a product lifespan based on specific use conditions. Monitoring can be done in various ways depending on the specific product and use.

## DESIGN GUIDELINES//

- Regular inspection intervals should be considered for monitoring of components or products.
- Embedded monitoring devices can be considered as a means to provide hands-off monitoring. This can take the form of various Internet-of-Things solutions.
- Sample or coupon testing (e.g., fatigue, strength) of used components can be done to extrapolate the overall status of a component.
- Digital measurement and identification systems are also a means to monitor components.



#### **DEMONSTRATOR EXAMPLE//CONENOR**

Conenor's wood-fiber plastic composites assume a number of standardized cross-sectional profiles that are extruded to length. This facilitates their use across a wide range of applications.

# Standardization

---

X



## DESCRIPTION//

Standardization is about using well known, defined, and widely used components, processes, dimensions, and materials in the design of a product. It could also refer to developing a standard layout for the product or product range. This helps to improve part exchange, facilitating repair, reuse, and recovery. This design aspect relates but is not restricted to industry standardization.

## DESIGN GUIDELINES//

- Standardisation comes in many forms. These could be standard: components (connections, bearings, etc); construction codes; dimensional tolerances; certification and inspection procedures; standard layouts across product (ranges); basic or standard available tools.

X



# VIANOVA WHOLE VEHICLE LIFE CYCLE

Proposed 20 year vehicle life with periodic remanufacture of systems and components to keep vehicle in 'as new' state. This extended life cycle, with built in remanufacture, minimises use of resources and keeps materials in circulation for longer. Ease of disassembly is built into the design so that only those components with significant degradation are replaced. An appropriate business model is being developed (in parallel with the technical processes) wherein a leasing or sharing type of use case is employed to optimise the financial benefits for all parties. Over time supply chain companies will engage with this process, to enable certain parts and assemblies to be returned to suppliers for remanufacturing.

**Notes:**

Mileage is not indicated here but will vary according to type of use, and higher mileage will normally increase wear and tear on vehicle.

Service and regular maintenance intervals are not shown on diagram but will fall at normal vehicle service periods, eg. 1 year.

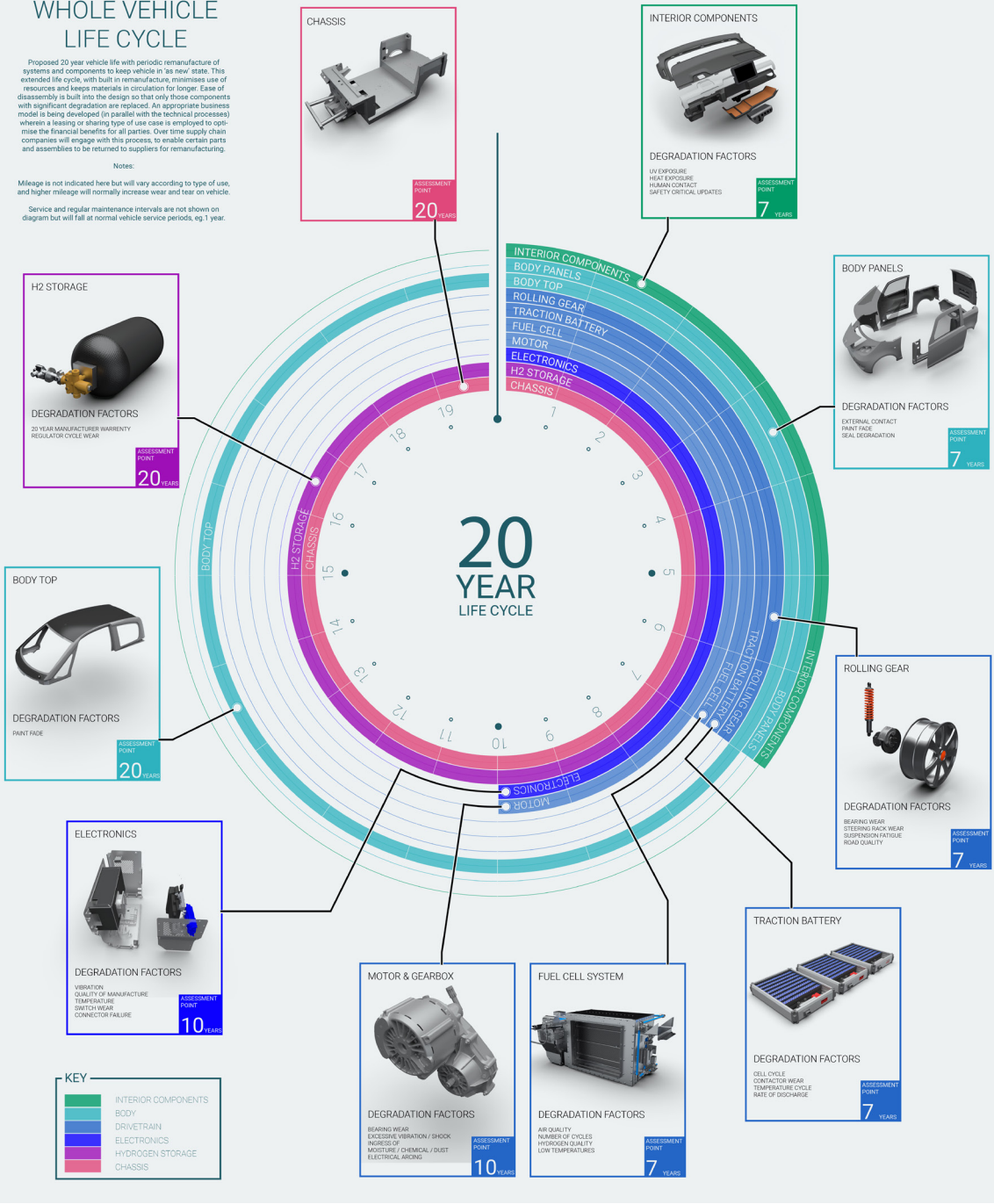

## DEMONSTRATOR EXAMPLE//MICROCAB

Microcab worked extensively on planning vehicle life cycles and repair schedules to maximize vehicle lifespan.

# Timing and planning

---

Y



## DESCRIPTION//

Timing and planning is often needed to extend a product lifetime and keep it functioning. This could be through service intervals, updates, component replacement, etc. It is also a sourcing mechanism to ensure return of the product post-use for reprocessing and recovering materials.

## DESIGN GUIDELINES//

- Establish expected component lifetimes and service intervals
- Plan for servicing or component replacement where necessary.
- Include planning for end-of-life and material recovery procedures in the design phase.

# Rödtråd

Circularity as a common thread in the new line of furniture from IKEA



Refurbish  
& Recycle

Reuse

Prolong

## DEMONSTRATOR EXAMPLE//RODTRAD

This student example project uses a red string mechanism to enable the disassembly and reassembly of this range of products. The red string serves not only as a fastening system, but also as a means to storytell that the product can be continuously disassembled and reassembled.

# Circular Storytelling

---

Z



## DESCRIPTION//

Circular storytelling is about conveying the circular narrative of the product to the stakeholders along the value chain, to inform and involve them in closing the loop. These stakeholders vary and may need different types of communication. One can think of e.g. enclosed documentation or use-cues integrated in the design itself. This is important as a switching from a linear to a circular economy requires all levels of stakeholders to engage with the process.

## DESIGN GUIDELINES//

- The first stage of circular storytelling is developing a thorough understanding of the circular strategy that a specific product or component has.



Chapter 4

# Tools



# Life Cycle Exploration Sheet

The product lifecycle exploration sheet can be used to explore the product, actors and actions along the product lifecycle. The sheet can be used in group sessions to stimulate discussion and create a shared understanding of the product lifecycle and circular opportunities. The session starts with a product description, and is followed by identifying stakeholders for each phase in the product value chain. Finally, the recovery loops can be explored, describing potential recovery actions to return the product, its parts or materials, from end of use to the value chain.

More information about the lifecycle exploration sheet can be found at [www.ecobulk.eu](http://www.ecobulk.eu).

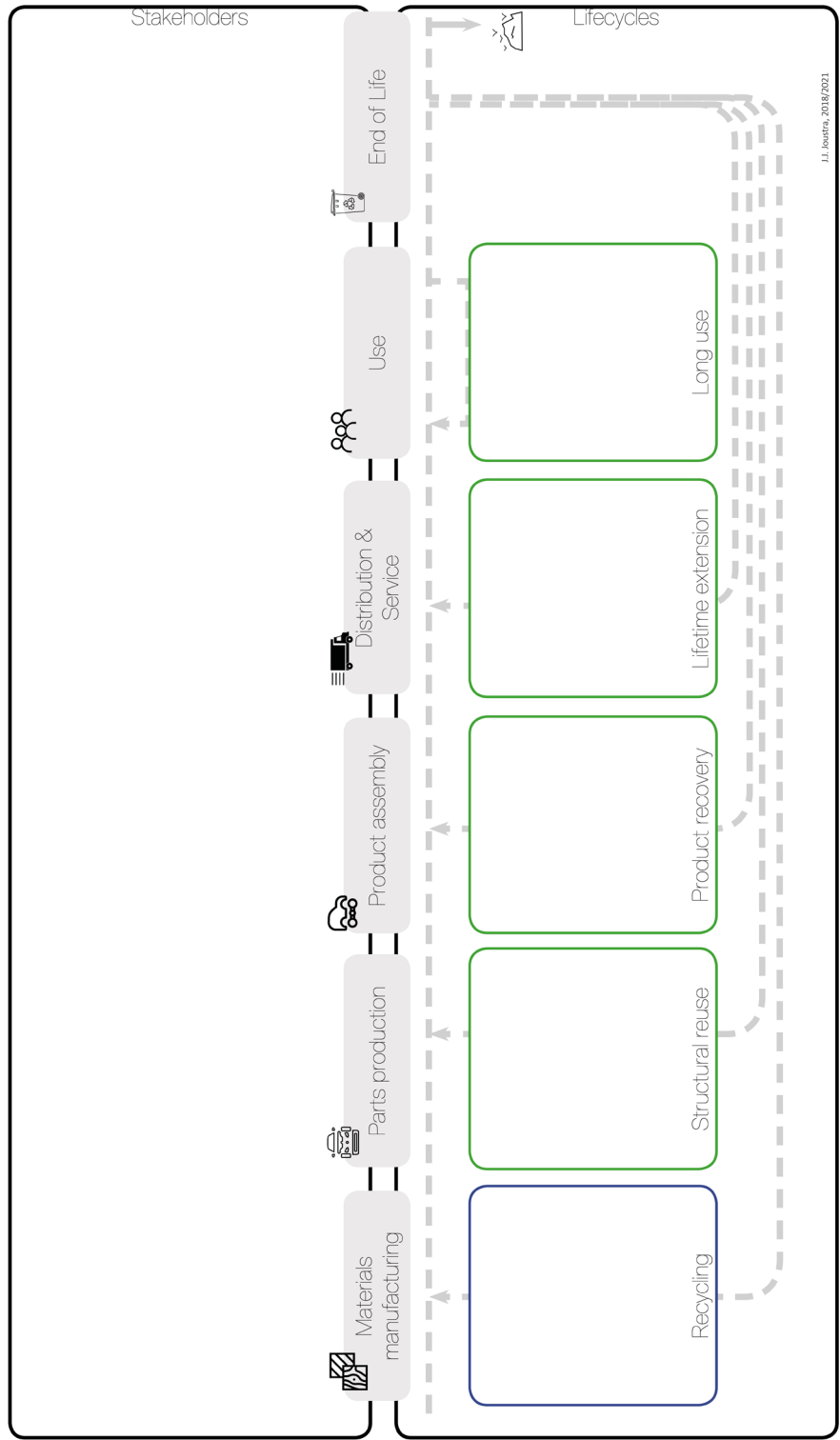



# Disassembly Map

The disassembly map is a method to visually map the disassembly of a product, showing different routes towards target components. In any given product, certain components are of particular importance as they might have a high failure rate, a high embodied environmental impact, or are of particular economic value. Accessing these components facilitates repair, recycling, or component harvesting, given the specific circular strategy under consideration. In this method, the ease of disassembly of a given product is assessed using four main parameters: disassembly sequence and depth, types of tools required, fastener reusability and reversibility, and disassembly time. Insights gathered from a disassembly map analysis can be used by designers in an iterative design process to optimize the product for disassembly, an important part of circular product design.

More information about the disassembly map can be found in the article “The Disassembly Map: A new method to enhance design for product repairability”, 2021, by De Fabio, Bakker, Flipsen, and Balkenende.

# Disassembly Map

Vacuum cleaner 1.  
Low-end Bagless, Brand A.

Francesco De Fazio et al.

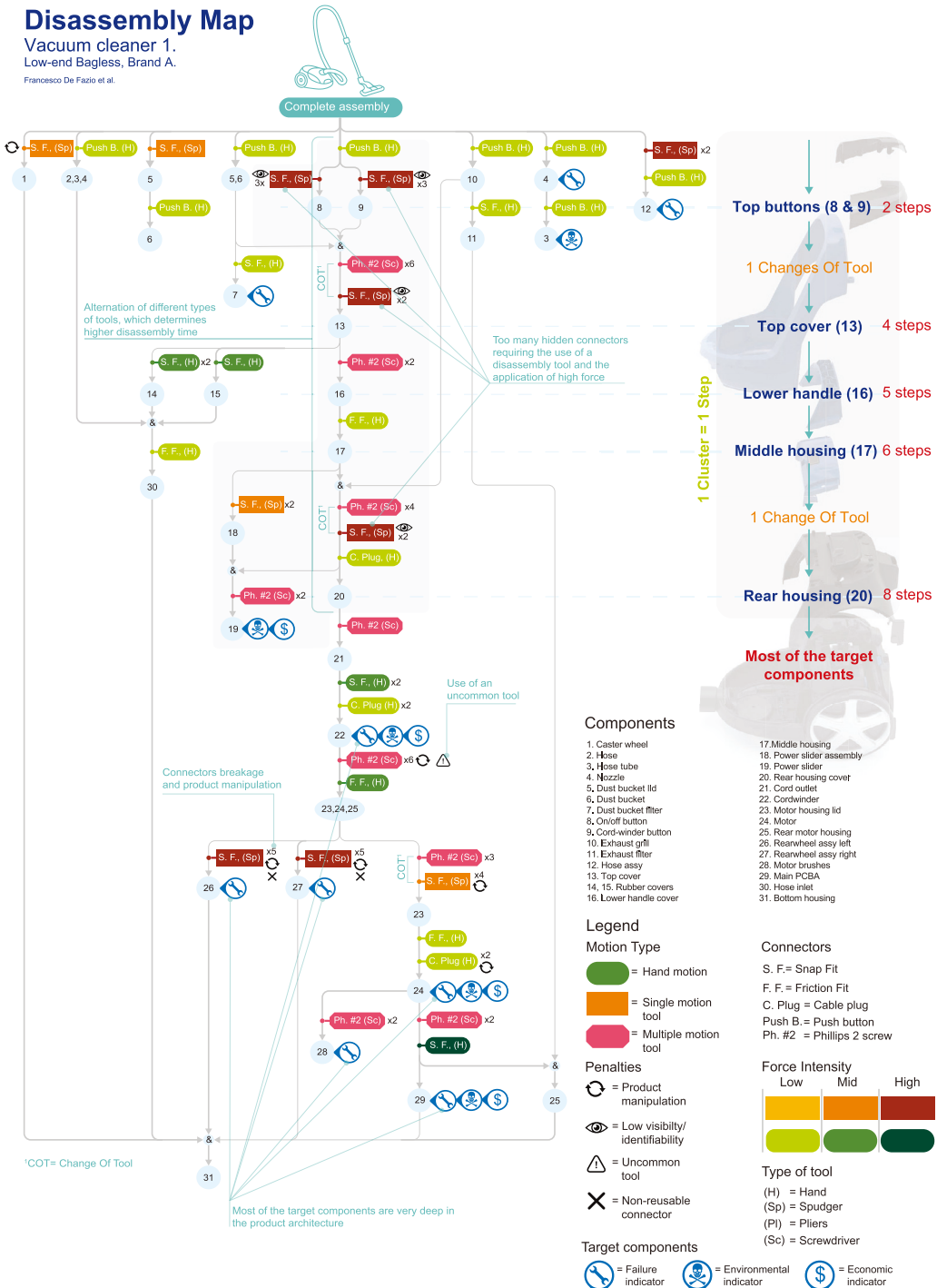

Fig. 9. Disassembly Map of the original architecture of vacuum cleaner #1.

# Fastener Finder

Fasteners and connections are the key to unlocking a product's parts and interior, necessary for product-level circular strategies. Fasteners are typically selected based on criteria such as assembly time, cost and strength. But for lifetime extension and product recovery interventions, such as maintenance and remanufacturing, disassembly and reassembly become critical factors. As such, selecting fasteners that enable these processes is necessary for a circular product.

Fasteners also play an important role at the material-level. While most materials are recyclable, mixing materials in a product often hinders the feasibility of recycling. Contamination of material streams can arise from material compositions, for example alloys or fibre-reinforced composites, from component compositions that are difficult or unfeasible to separate, and from scrap mixtures that cannot be separated in bulk. The fastener finder helps to address these issues in the design stage. While designers do not prefer fasteners that cause recycling or dismantling headaches, in many cases the choice of glue, tape, metal, or plastic takes materials out of circulation.

The fastener finder is a tool that was developed to address these problems in the design stage, by making it easy for designers to know to what extent a fastener contaminates base materials, can be disassembled viably, and can be separated from base materials in bulk. It allows for the comparison of all fasteners, showing engineering information, lifecycle costs, and circularity properties. This tool makes it possible to find the most economical and environmental fastening solutions for any given problem.

More information about the fastener finder can be found at [www.ecobulk.eu](http://www.ecobulk.eu)

use the wizard

Apply filters

Click here or hit enter

Design requirements

Fastener type

Repair, remanufacture and recycling

Apply filters

Show / hide fastener data by column:

Image	Type	Category	Description	Drive	Material	Ø or width (mm)	Length (mm)	Pull load (kN)	Shear load (kN)	Circularity
Not circular because		recycles with A	recycles with B	reuse/replace	Approx. price (€)	Lifecycle cost	Fastening action	Assembly time (s)	Disassembly time (s)	
Ease of disassembly		Disassembly time (s)	Repair time (s)	Reman time (s)	Toolspace A	Toolspace B	Min thickness	Max thickness		
Part B min. thickness		Thread length								

Search:  Showing 1 to 72 of 72 entries Show  entries

Image	Type	Description	Material	Ø or width (mm)	Pull load (kN)	Circularity	recycles with A	Approx. price (€)	Lifecycle cost	Fastening action	Assembly time (s)	Disassembly time (s)
<b>Bolts</b>												
	Bolts	Hex Bolts D4 x 10	Standard carbon steel	4	1.21	8.33 excellent	-	0.016	0.022	power tool	1.44	2: common tools 20.6
	Bolts	Hex Bolts D4 x 10	PA6 Nylon	4	0.724	8.33 excellent	-	0.045	0.051	power tool	1.44	2: common tools 20.6
	Bolts	Wing Bolts D4 x 10	Standard carbon steel	4	1.21	8.33 excellent	-	0.016	0.022	Spin with fingers	1.37	2: common tools 16
	Bolts	Wing Bolts D4 x 10	PA6 Nylon	4	0.724	8.33 excellent	-	0.045	0.051	Spin with fingers	1.37	2: common tools 16
	Bolts	Phillips Cap Bolts D4 x 10	Standard carbon steel	4	1.21	8.33 excellent	-	0.016	0.022	power tool	1.44	2: common tools 24.2
	Bolts	Phillips Cap Bolts D4 x 10	PA6 Nylon	4	0.724	8.33 excellent	-	0.045	0.051	power tool	1.44	2: common tools 24.2
	Bolts	Hex Flange bolts D4 x 10	Standard carbon steel	4	1.21	8.33 excellent	-	0.016	0.022	power tool	1.44	2: common tools 20.6
	Bolts	Hex Flange bolts D4 x 10	PA6 Nylon	4	0.724	8.33 excellent	-	0.045	0.051	power tool	1.44	2: common tools 20.6
	Bolts	Phillips Flange bolts D4 x 10	Standard carbon steel	4	1.21	8.33 excellent	-	0.016	0.022	power tool	1.44	2: common tools 24.2
	Bolts	Phillips Flange bolts D4 x 10	PA6 Nylon	4	0.724	8.33 excellent	-	0.045	0.051	power tool	1.44	2: common tools 24.2
	Bolts	Phillips Six bolts D4 x 10	Standard carbon steel	4	1.21	8.33 excellent	-	0.016	0.022	power tool	1.44	2: common tools 24.2
	Bolts	Phillips Six bolts D4 x 10	PA6 Nylon	4	0.724	8.33 excellent	-	0.045	0.051	power tool	1.44	2: common tools 24.2
<b>Screws</b>												
	Screws	Hex Wood screws D4 x 10	Standard carbon steel	4	1.88	8.33 excellent	-	0.015	0.021	power tool	1.44	2: common tools 17.4
	Screws	Phillips Wood screws D4 x 10	Standard carbon steel	4	1.88	8.33 excellent	-	0.015	0.021	power tool	1.44	2: common tools 19
	Screws	Hex Pin screws D4 x 10	Standard carbon steel	4	1.88	8.33 excellent	-	0.015	0.021	power tool	1.44	2: common tools 17.4
<b>Snaps</b>												
	Snaps	Pull release snaps 4mm	PA6 Nylon	4	0.864	8.67 excellent	-	0.007	0.009	place or snap	0.54	1: without tools 3.16
	Snaps	Pull release snaps 30mm	PA6 Nylon	30	6.48	8.67 excellent	-	3.11	3.11	place or snap	0.54	1: without tools 7
	Snaps	Push release snaps 4mm	PA6 Nylon	4	1.08	8.33 excellent	-	0.007	0.009	place or snap	0.54	2: common tools 5.66
	Snaps	Push release snaps 30mm	PA6 Nylon	30	8.1	8.33 excellent	-	3.11	3.11	place or snap	0.54	2: common tools 19
<b>irr-Snaps</b>												
	In-Snaps	Irreversible snaps 4mm	PA6 Nylon	4	1.08	5.74 poor	-	0.007	0.009	place or snap	0.54	5: with damage 49.2
	In-Snaps	Irreversible snaps 30mm	PA6 Nylon	30	8.1	4.69 poor	-	3.11	3.11	place or snap	0.54	5: with damage 103
<b>Adhesives</b>												
	Adhesives	Glue Wood glue (PVA) 4 x 10	PVA glue	4	0.432	2 very poor	-	0.026	0.029	Apply with glue gun/ nozzle	0.72	7: Not separable 832
	Adhesives	Glue Wood glue (PVA) 30 x 10	PVA glue	30	3.24	2 very poor	-	2.98	2.98	Apply with glue gun/ nozzle	0.72	7: Not separable 1027
	Adhesives	Glue Polyurethane glue 4 x 10	PU glue	4	0.368	2 very poor	-	0.026	0.029	Apply with glue gun/ nozzle	0.72	7: Not separable 832
	Adhesives	Glue Polyurethane glue 30 x 10	PU glue	30	2.76	2 very poor	-	2.98	2.98	Apply with glue gun/ nozzle	0.72	7: Not separable 1027
	Adhesives	Glue Epoxy resin (EK glue) 4 x 10	Epoxy glue	4	0.3	2 very poor	-	0.026	0.029	Apply with glue gun/ nozzle	0.72	7: Not separable 832
	Adhesives	Glue Epoxy resin (EK glue) 30 x 10	Epoxy glue	30	2.25	2 very poor	-	2.98	2.98	Apply with glue gun/ nozzle	0.72	7: Not separable 1027
	Adhesives	Glue Superglue (CA) 4 x 10	Cyanoacrylate superglue	4	0.568	2 very poor	-	0.026	0.029	Apply with glue gun/ nozzle	0.72	7: Not separable 832
	Adhesives	Glue Superglue (CA) 30 x 10	Cyanoacrylate superglue	30	4.26	2 very poor	-	2.98	2.98	Apply with glue gun/ nozzle	0.72	7: Not separable 1027
	Adhesives	Glue Hot glue (EVA) 4 x 10	EVA glue	4	0.228	5 poor	-	0.026	0.029	Apply with glue gun/ nozzle	0.72	0: Self-disassembling 3.04
	Adhesives	Glue Hot glue (EVA) 30 x 10	EVA glue	30	1.71	5 poor	-	2.98	2.98	Apply with glue gun/ nozzle	0.72	0: Self-disassembling 4
	Adhesives	Glue Hot glue (PI) 4 x 10	PI glue	4	0.468	5 poor	-	0.026	0.029	Apply with glue gun/ nozzle	0.72	0: Self-disassembling 3.04
	Adhesives	Glue Hot glue (PI) 30 x 10	PI glue	30	3.51	5 poor	-	2.98	2.98	Apply with glue gun/ nozzle	0.72	0: Self-disassembling 4

Showing 1 to 72 of 72 entries

Previous  Next

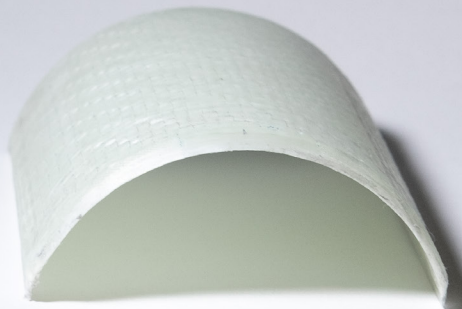

Chapter 5

# Closing Remarks



# About Ecobulk

Project Ecobulk demonstrated a circular economy for products containing composites from three industry sectors: construction, furniture and automotive. These sectors have large impacts and opportunities for sustainable development. The project ran from 2017 to 2021 and the consortium included over 30 partners spread out across Europe. Together they revisited the materials, business model and design for a set of demonstrator products. In addition, researchers and students at Delft university of technology performed design case studies to explore recovery pathways and design practices. The Circular Composites design guide brings together the lessons learnt in all design cases and illustrates them with pictures of the finalized demonstrators and design cases.

Ecobulk has received funding from the European Union's Horizon 2020 research and innovation program under grant agreement No 730456.



Circular Approach for Eco-Composite Bulky Product



# Featured Projects

The following projects have been featured in this design guide:

<b>Project Name</b>	<b>Designer/Company</b>
Ecobulk demonstrator	Conenor
Ecobulk demonstrator	CRF
Ecobulk demonstrator	Maier
Ecobulk demonstrator	Microcab
Ecobulk demonstrator	Moretti
WTB Table	Jelle Joustra
Reverse forming of PP glass fiber composites	Jelle Joustra
Fastener Finder	Bram van der Grinten
Unito	Riel Bessai
Bridge of Blades	Stijn Speksnijder
Repurposing composite products	Parshva Mehta
Reuse of shredded composites	Tjits Tuinhof
Ecojoint	Coen Ameln
Rödtråd	Fay de Grefte
Sofair So Good	Nina van der Klauw

Stock photo credits: © Can Stock Photo / mawear (redundancy), © Pexels (monitoring).









The circular composites design guide presents circular economy strategies, product design aspects and tools to (re-)design products containing composite materials for a circular economy.

A circular economy closes the loop for products, parts and materials, through reuse and recycling. In this guide you will find 5 circular economy strategies, 26 design aspects and 3 design tools specifically aimed at composite products. All have concise descriptions and inspirational examples developed in project Ecobulk and at Delft University of Technology.