

The Commons

Collective living environments for socially active ageing



SUPERMARKT

FIETS

Research

The Hague

Houtwijk







Ageing population

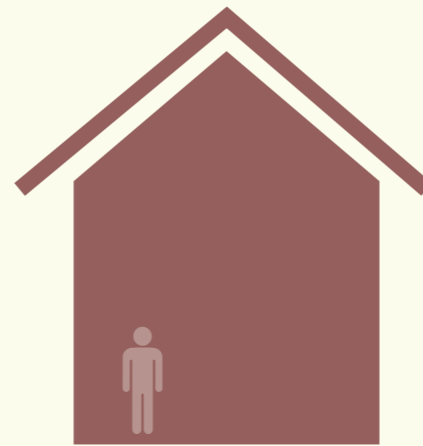

Mismatch between
households and housing

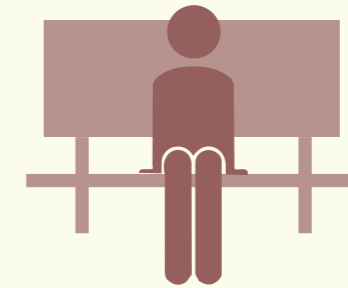

High level of loneliness

'How can the architectural design of the built environment support older adults in remaining socially active within their neighbourhood?'

'How can the architectural design of the built environment support older adults in remaining socially active within their neighbourhood?'

'Which social activities are important for older adults to remain socially active?'

'How can the architectural design of the built environment support older adults in remaining socially active within their neighbourhood?'

'Which social activities are important for older adults to remain socially active?'

'Which architectural design elements in the immediate residential environment encourage social interaction?'

'How can the architectural design of the built environment support older adults in remaining socially active within their neighbourhood?'

'Which social activities are important for older adults to remain socially active?'

'Which architectural design elements in the immediate residential environment encourage social interaction?'

'Which architectural design elements within the dwelling support older adults in ageing in place?'

'How can the architectural design of the built environment support older adults in remaining socially active within their neighbourhood?'

'Which **social activities** are important for older adults to remain socially active?'

'Which architectural design elements in the immediate residential environment encourage **social interaction**?'

'Which architectural design elements within the dwelling support older adults in **ageing in place**?'

Design guidelines

Design guidelines

For social interaction

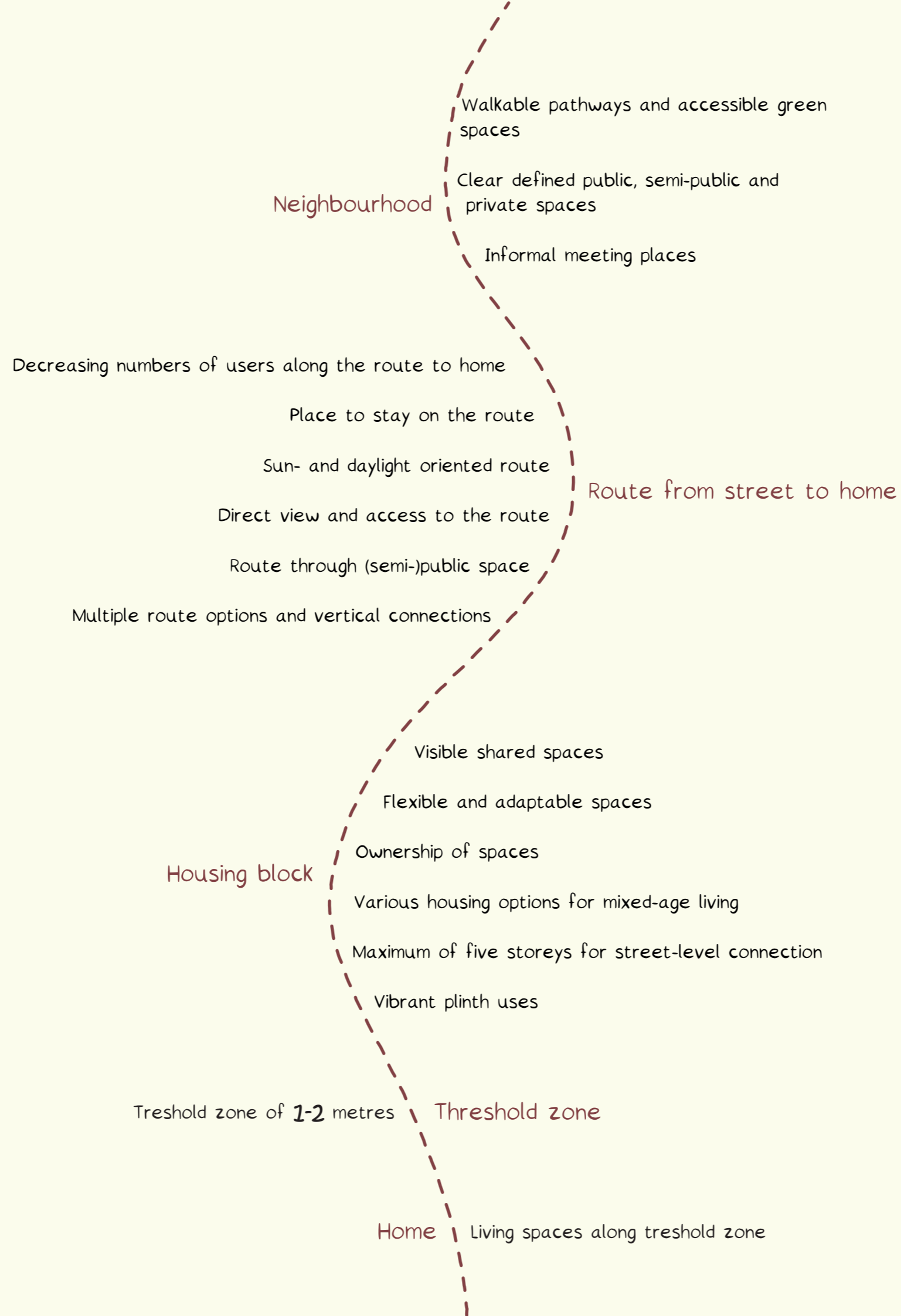

Design guidelines

For ageing place

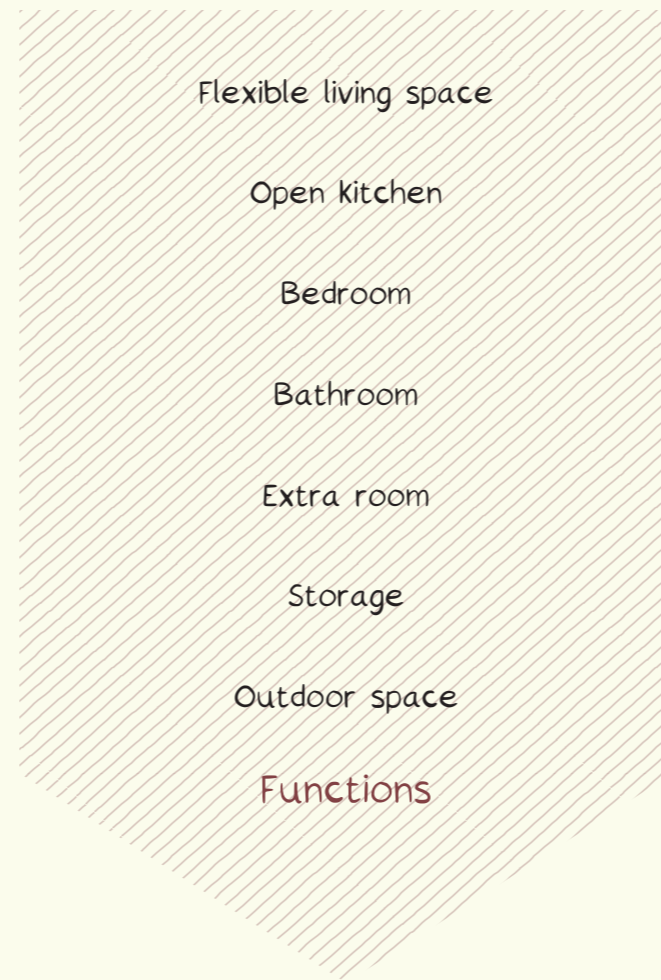

Age-friendly home



Design guidelines

Programme

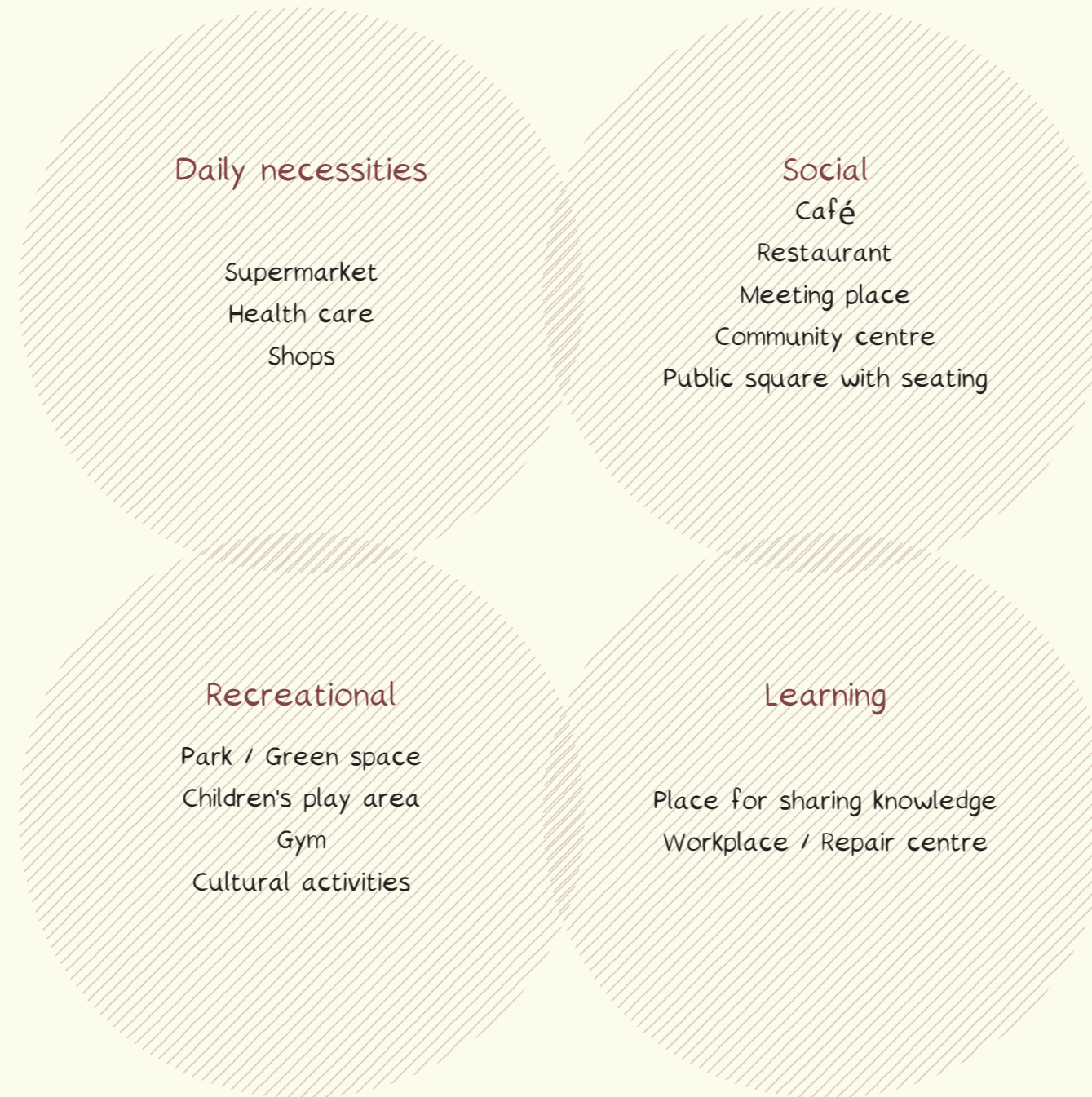

Design goal

A living environment that supports the social activity of older adults

Conceptual idea

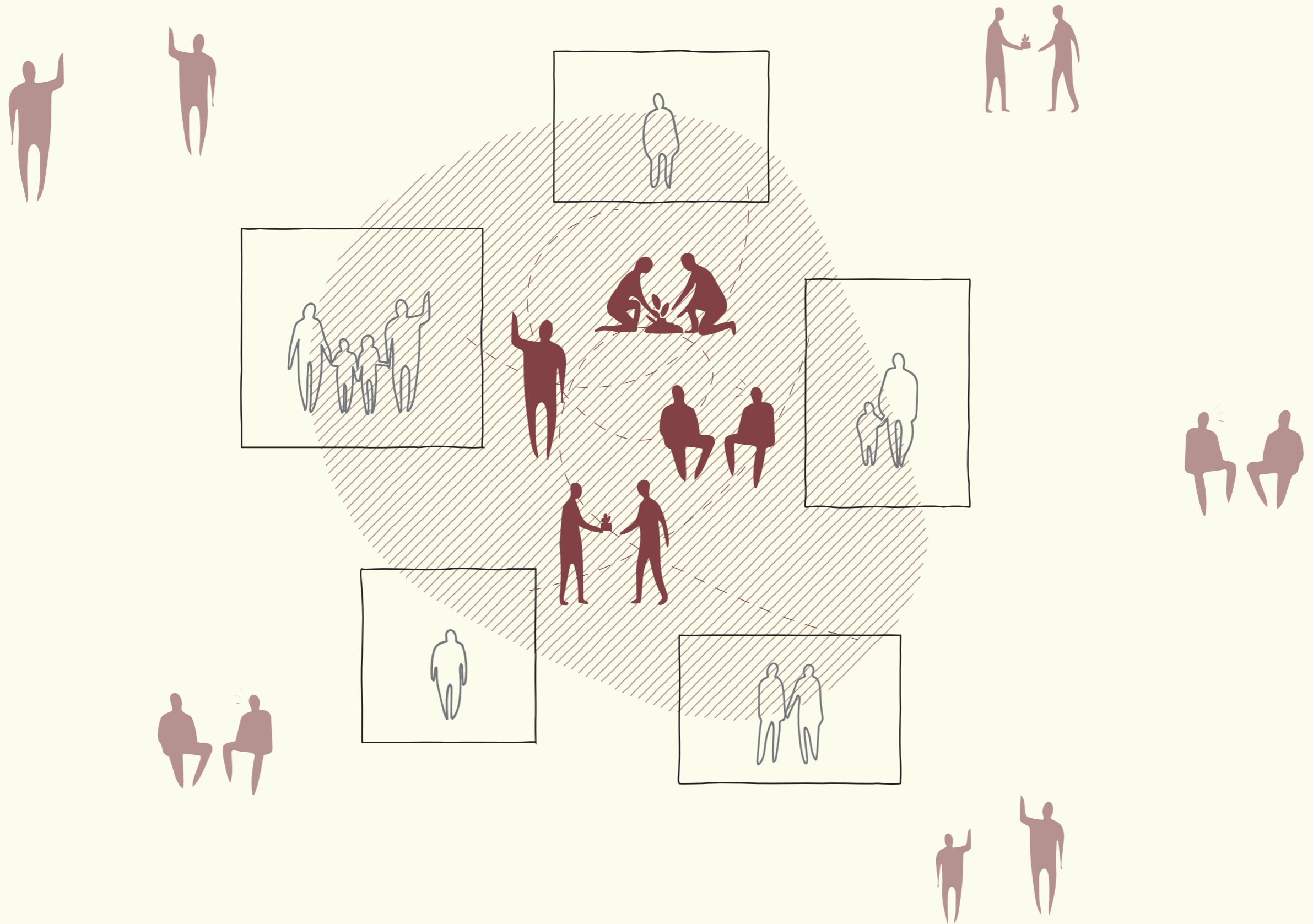

Site selection

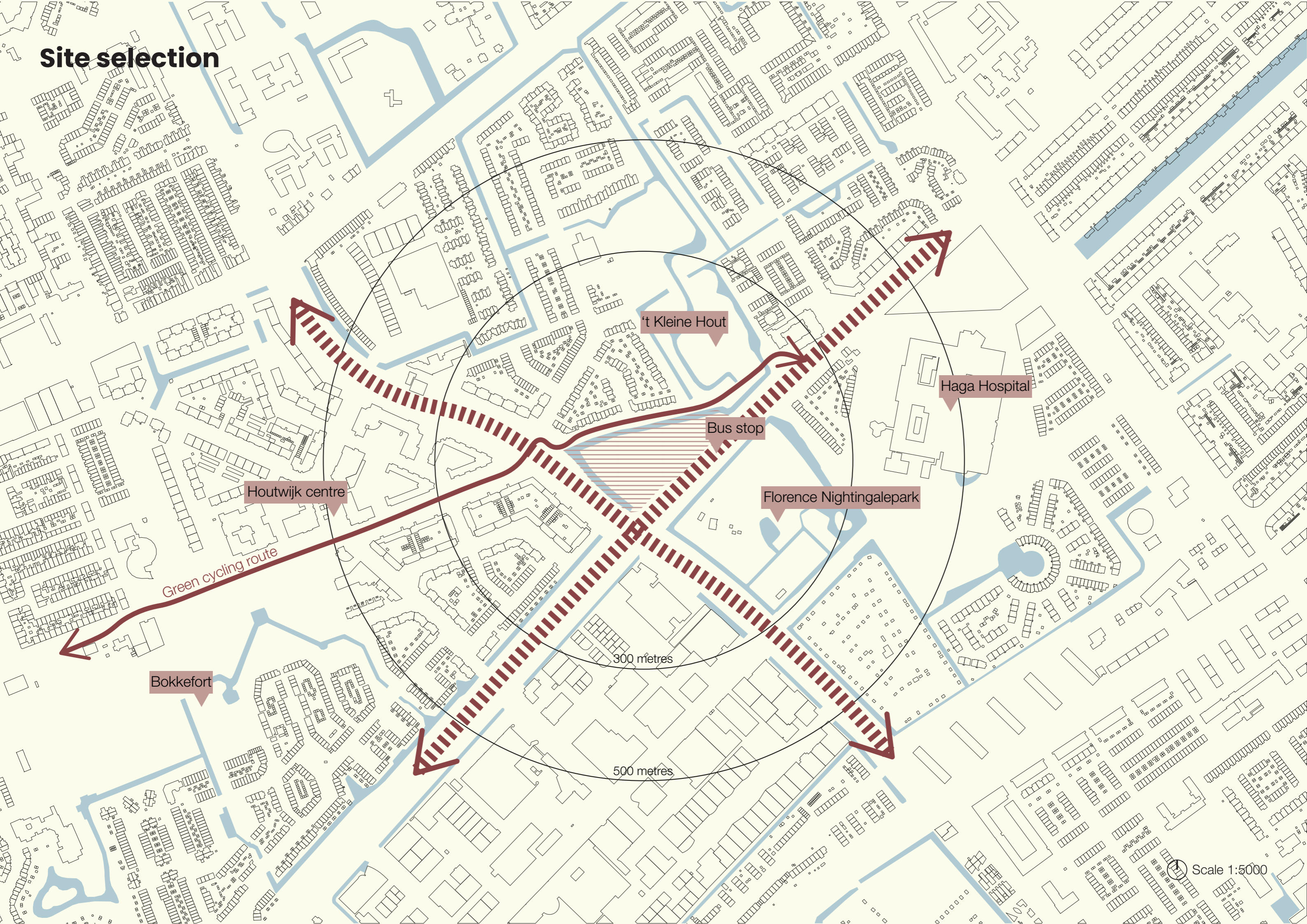

Green cycling route

Houtwijk centre

Bokkefort

t Kleine Hout

Bus stop

Florence Nightingalepark

Haga Hospital

300 metres

500 metres





Green cycling route



Busy main road

Mass evolution

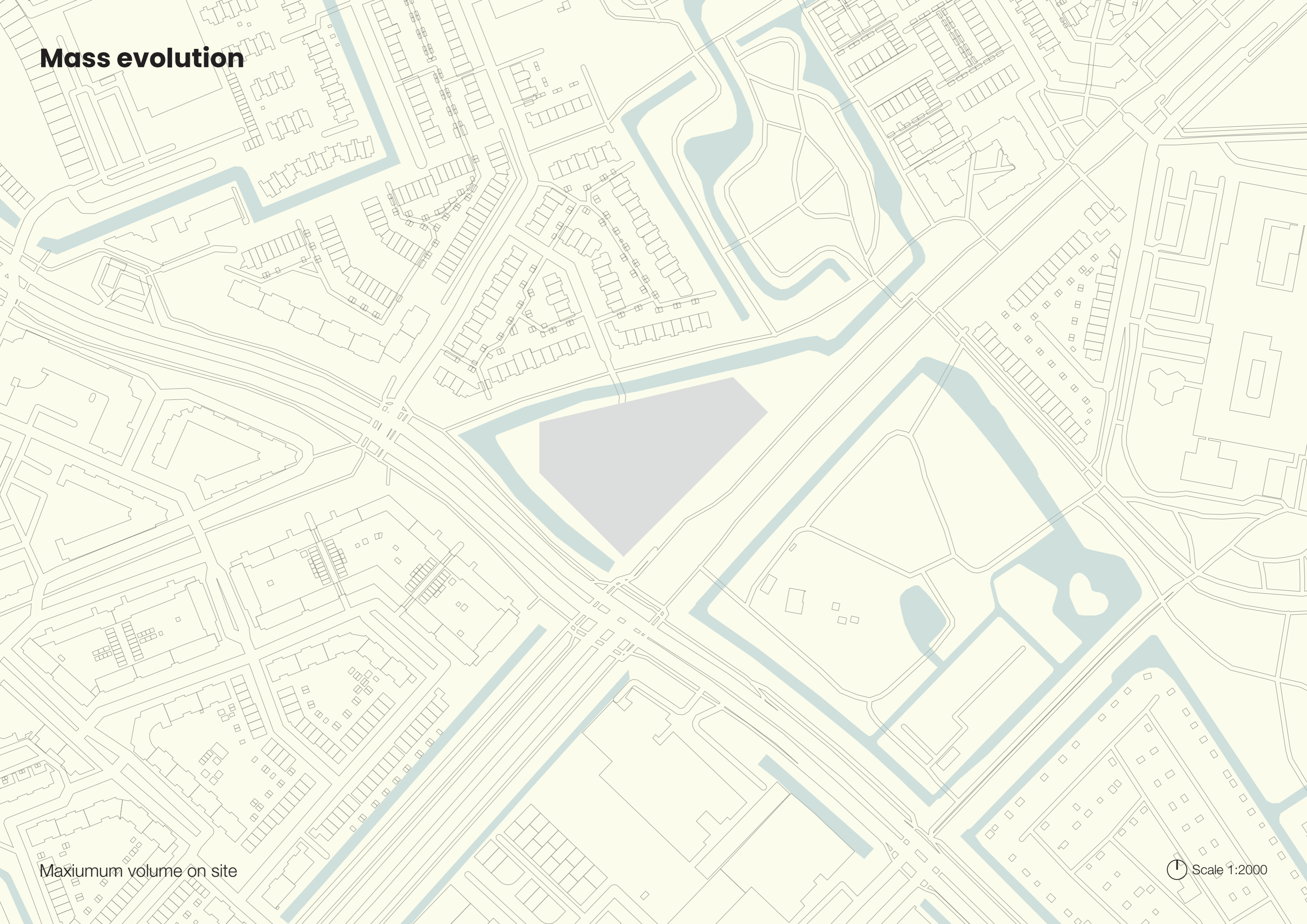

Maximum volume on site

Scale 1:2000

Mass evolution

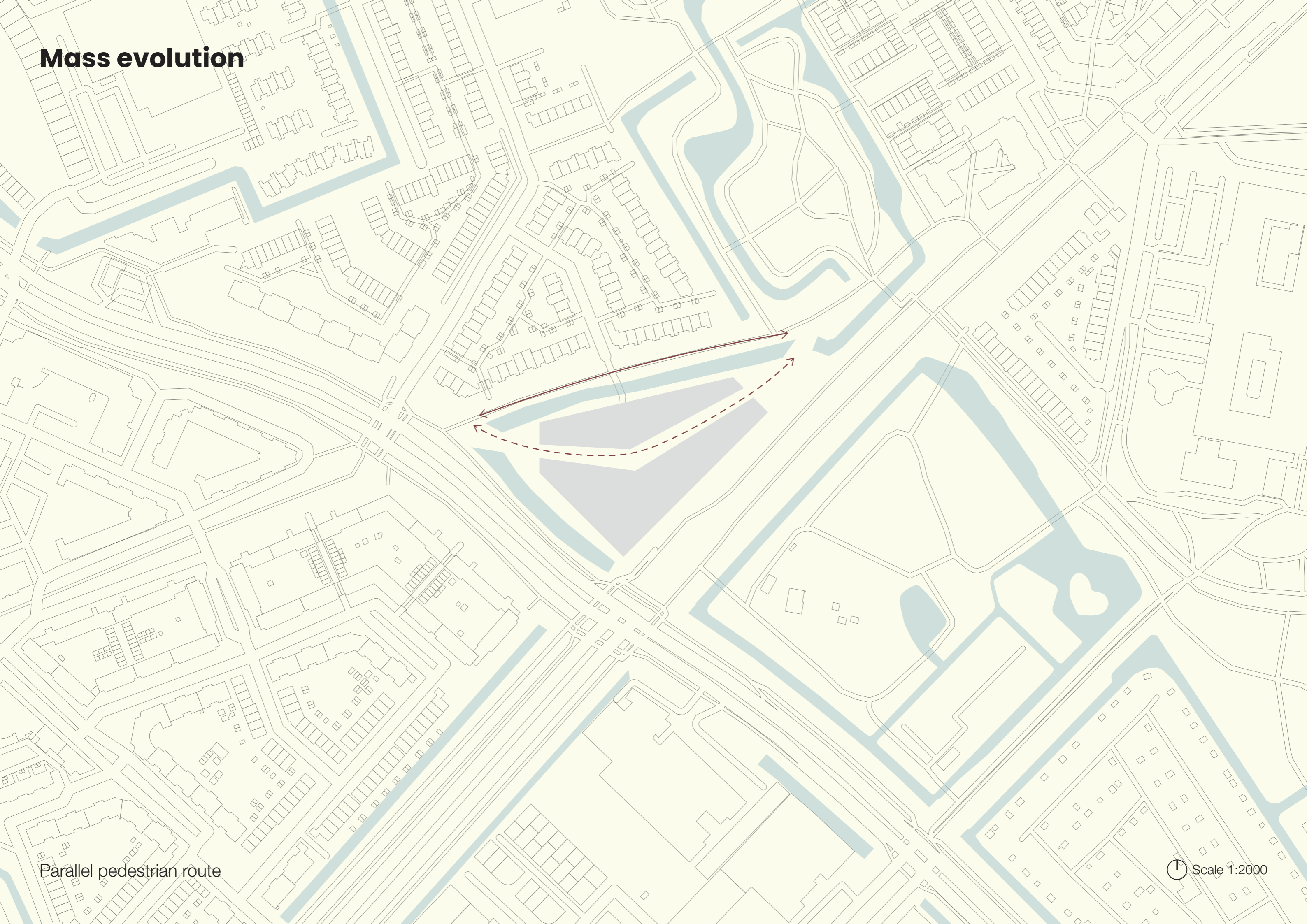

Parallel pedestrian route

Scale 1:2000

Mass evolution

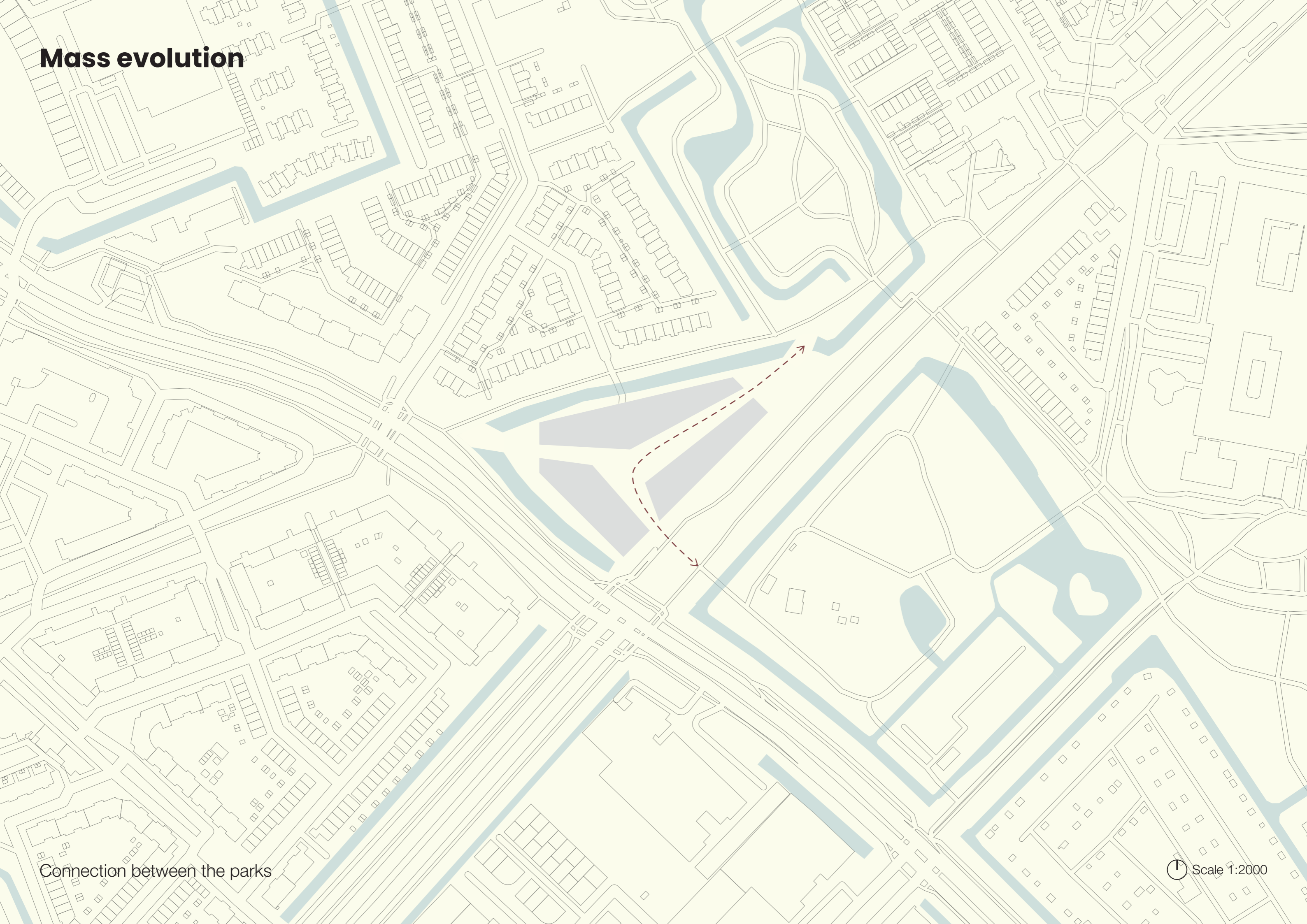

Connection between the parks

Scale 1:2000

Mass evolution

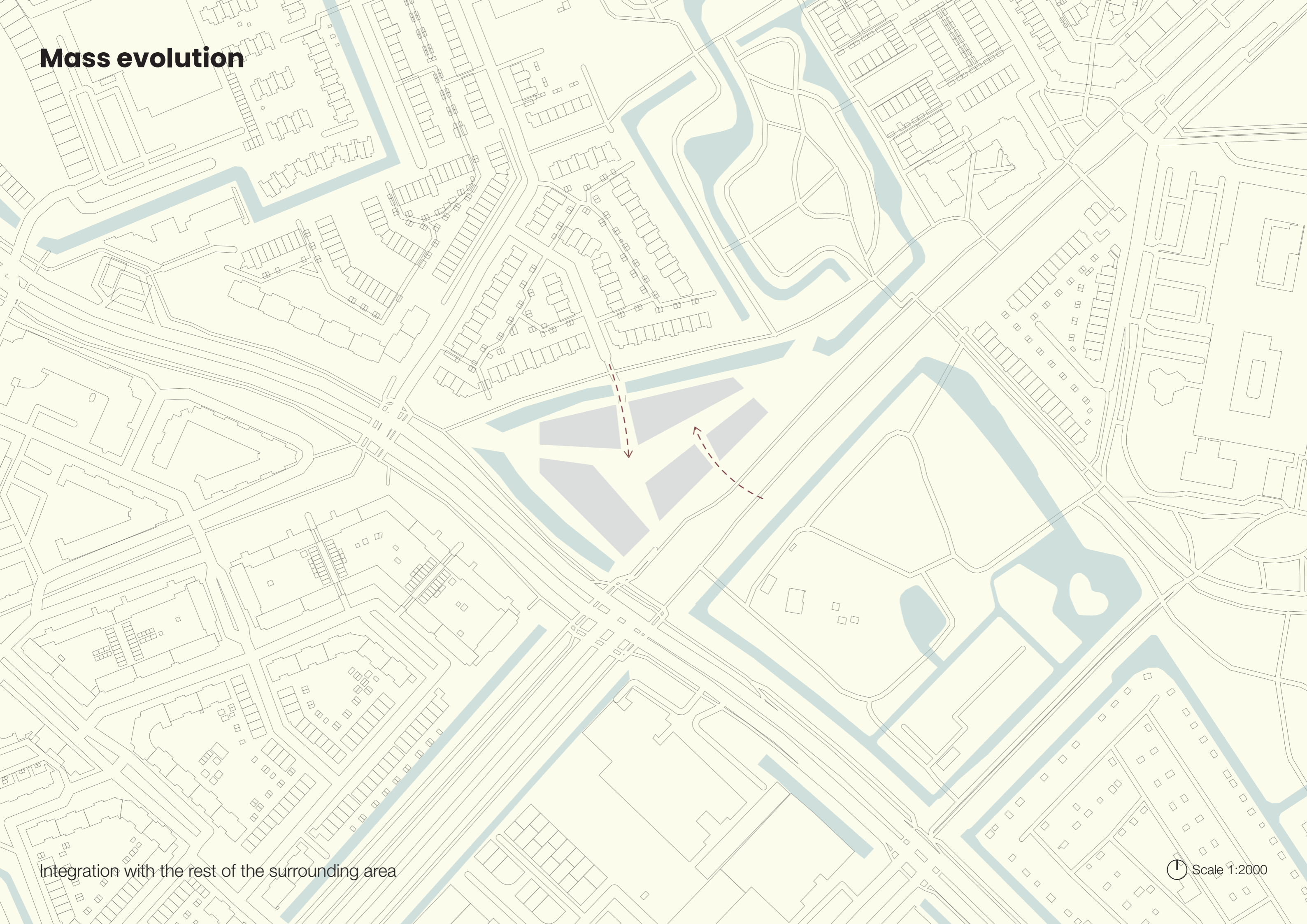

Integration with the rest of the surrounding area

Scale 1:2000

Site plans

Green inner street

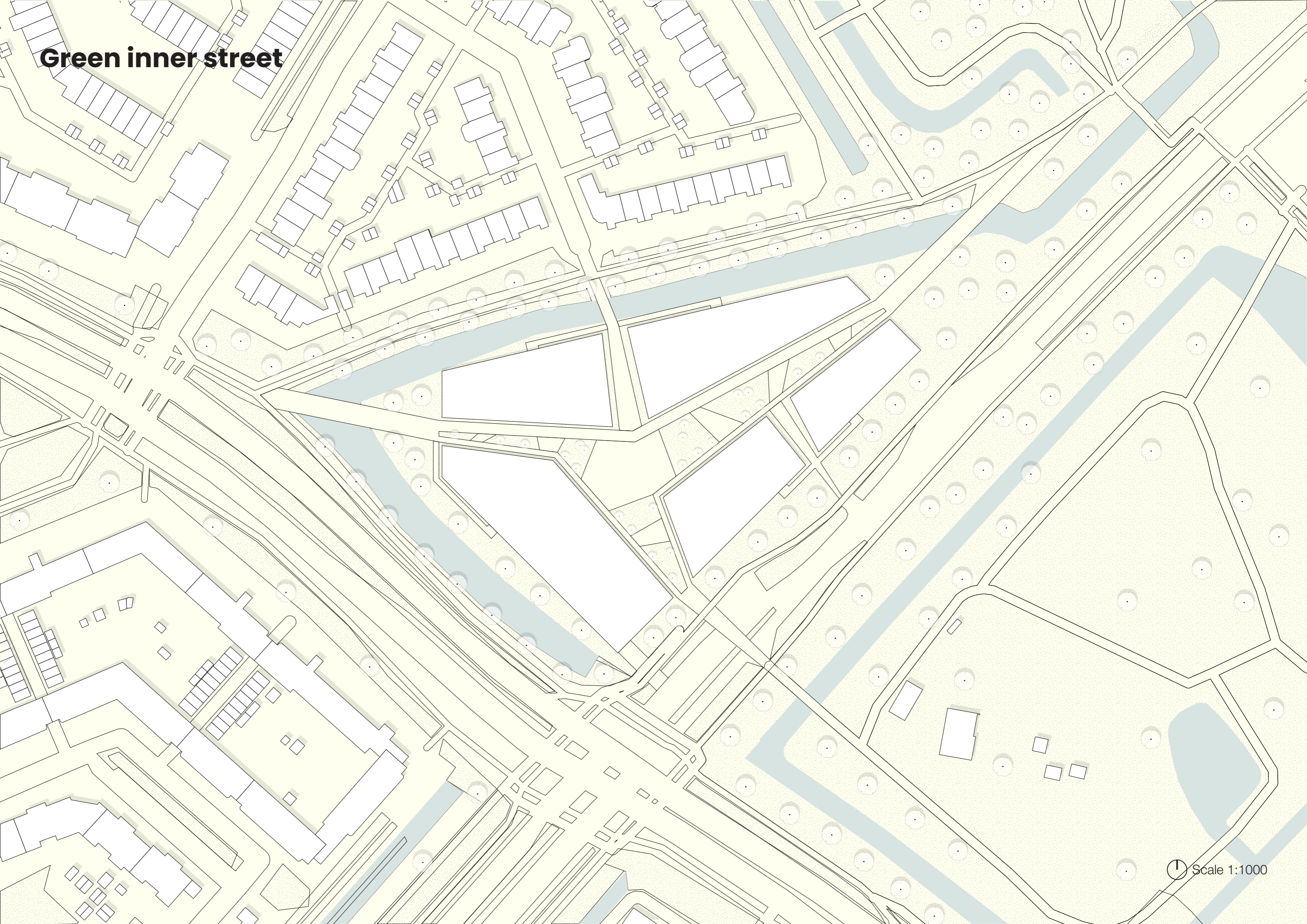

Ground floor plan

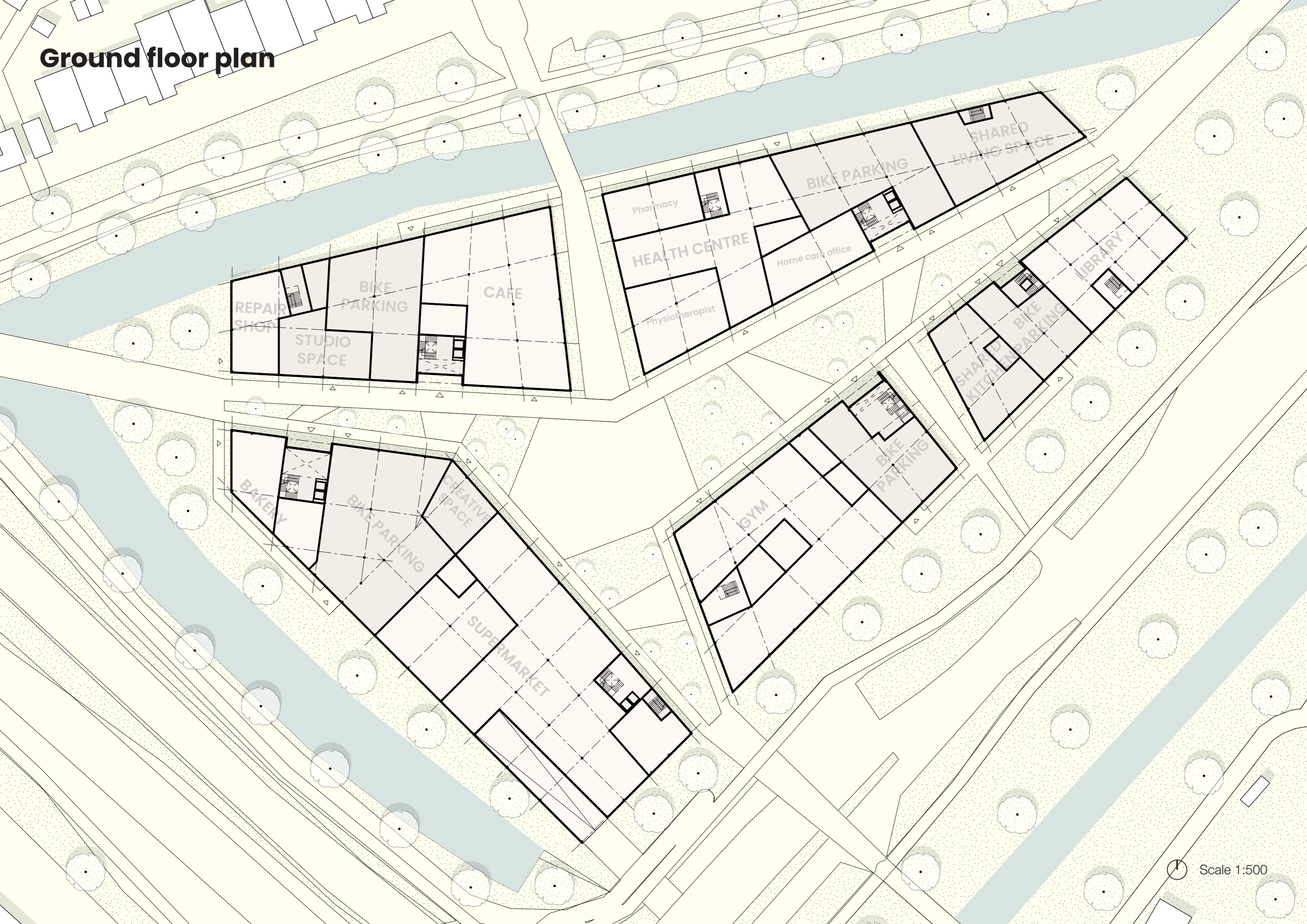

Mass carving

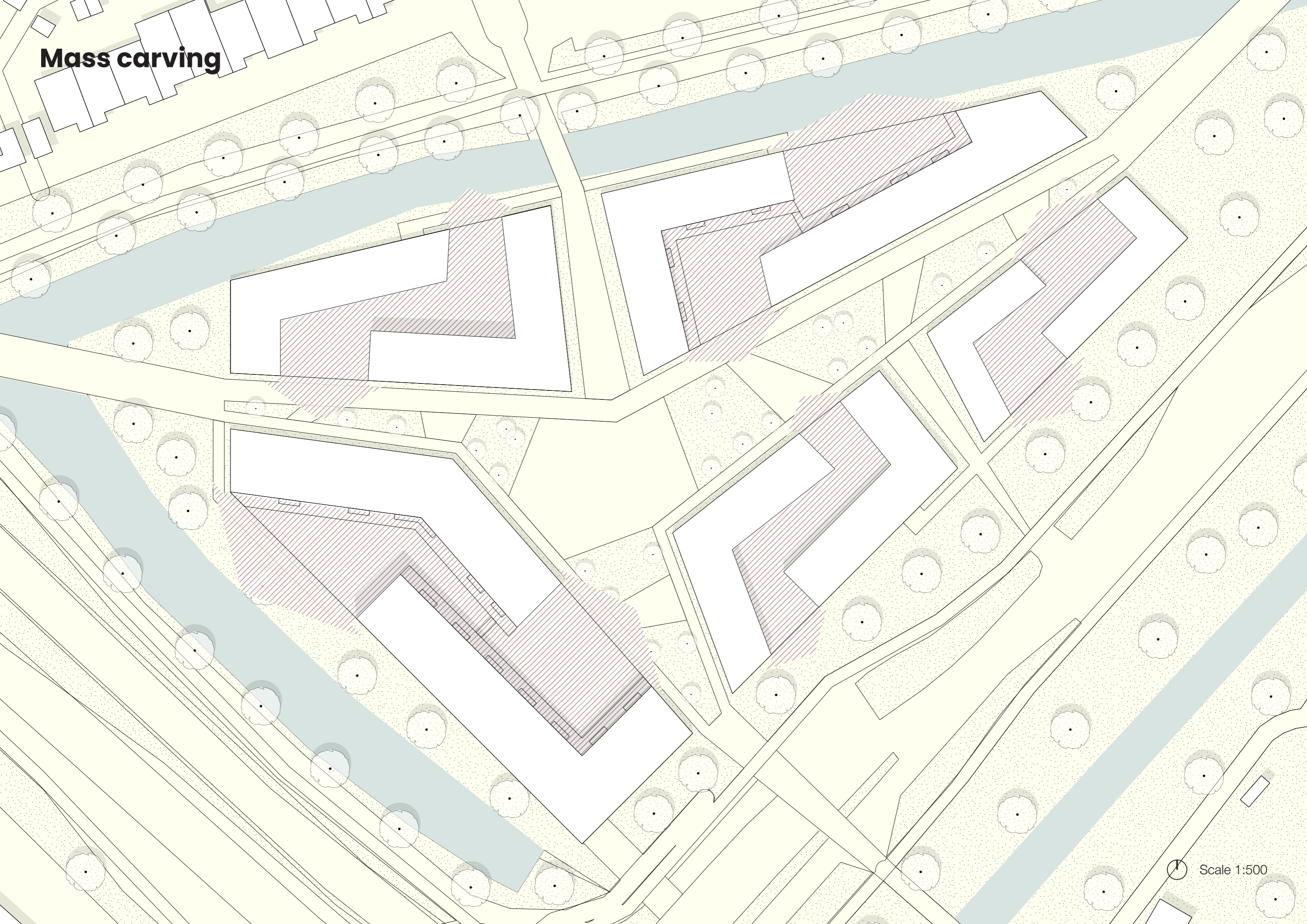

First floor plans

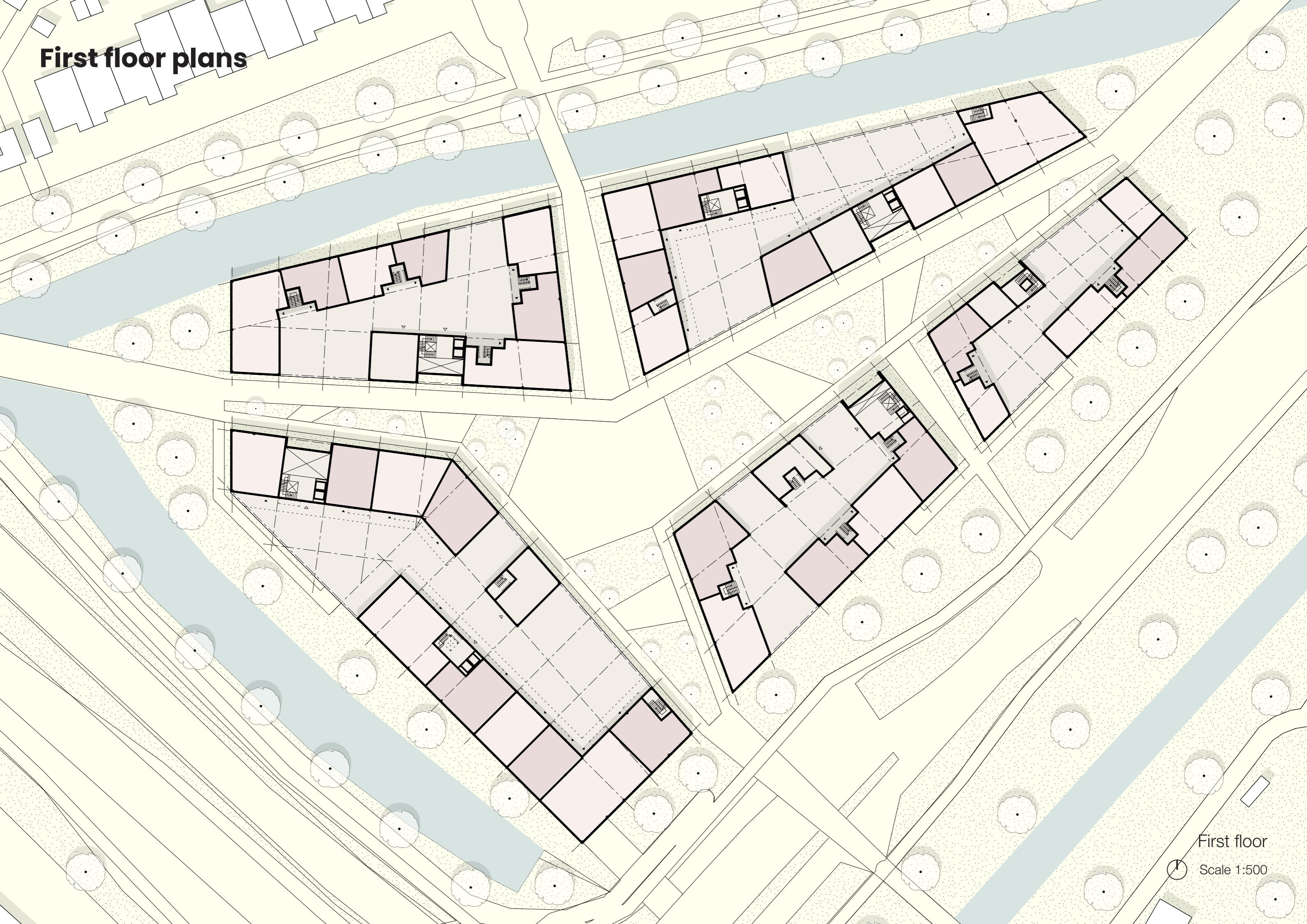

First floor

Scale 1:500

First floor plans



First floor

Scale 1:500

Floor plans

Floor plans Building A

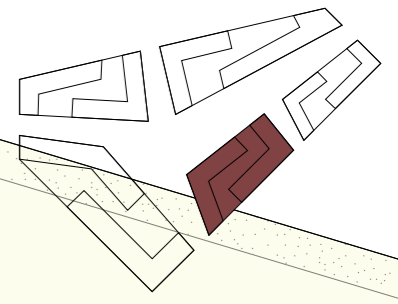

First floor

Scale 1:200

Floor plans Building A

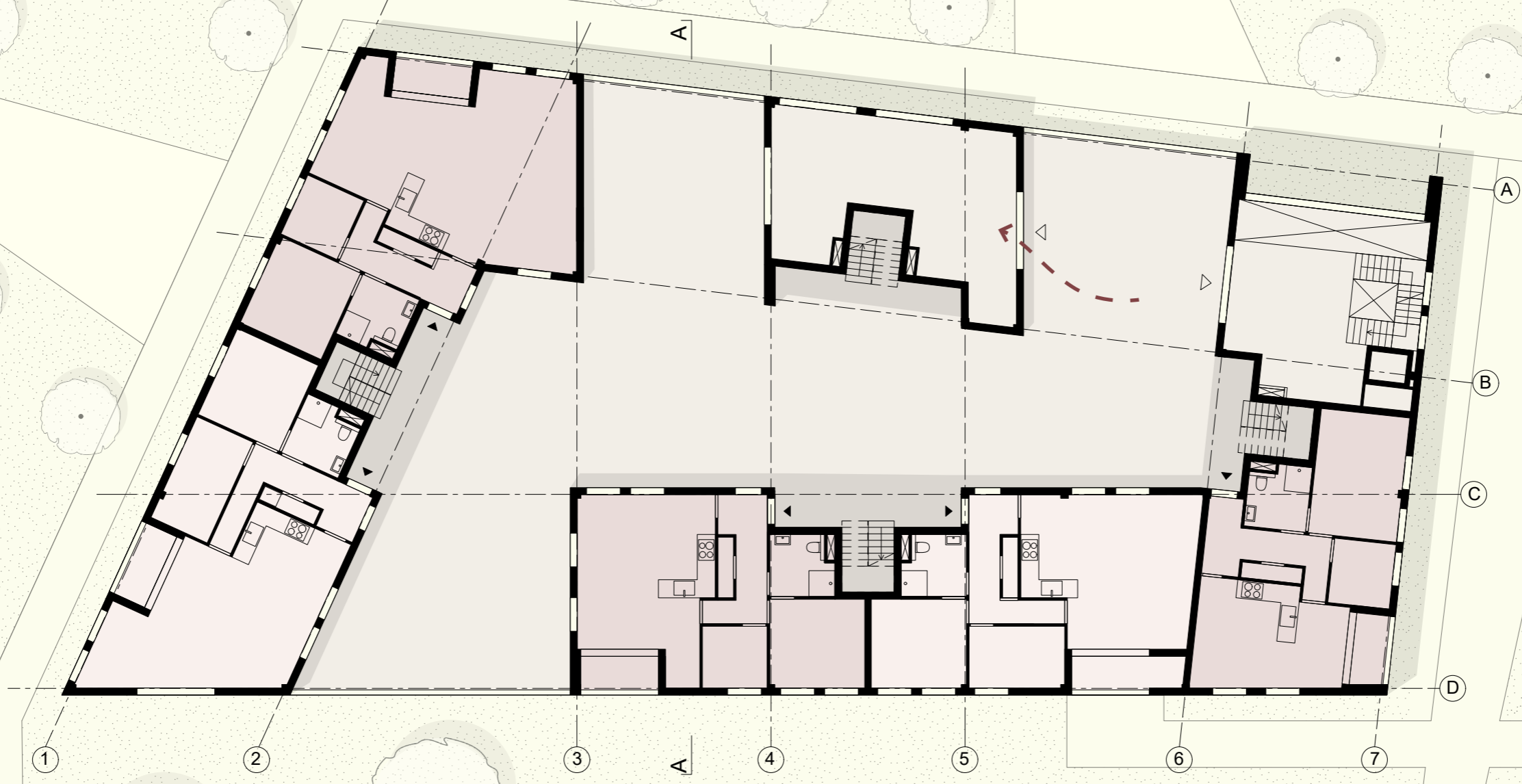
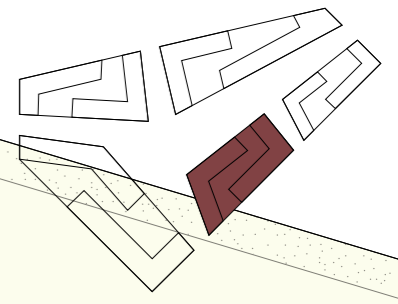

First floor

Scale 1:200

Floor plans Building A

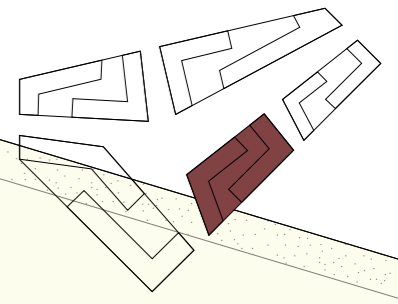

First floor

Scale 1:200

Floor plans Building A

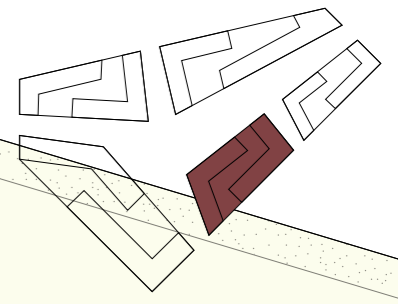

Second floor
Scale 1:200

Floor plans Building A

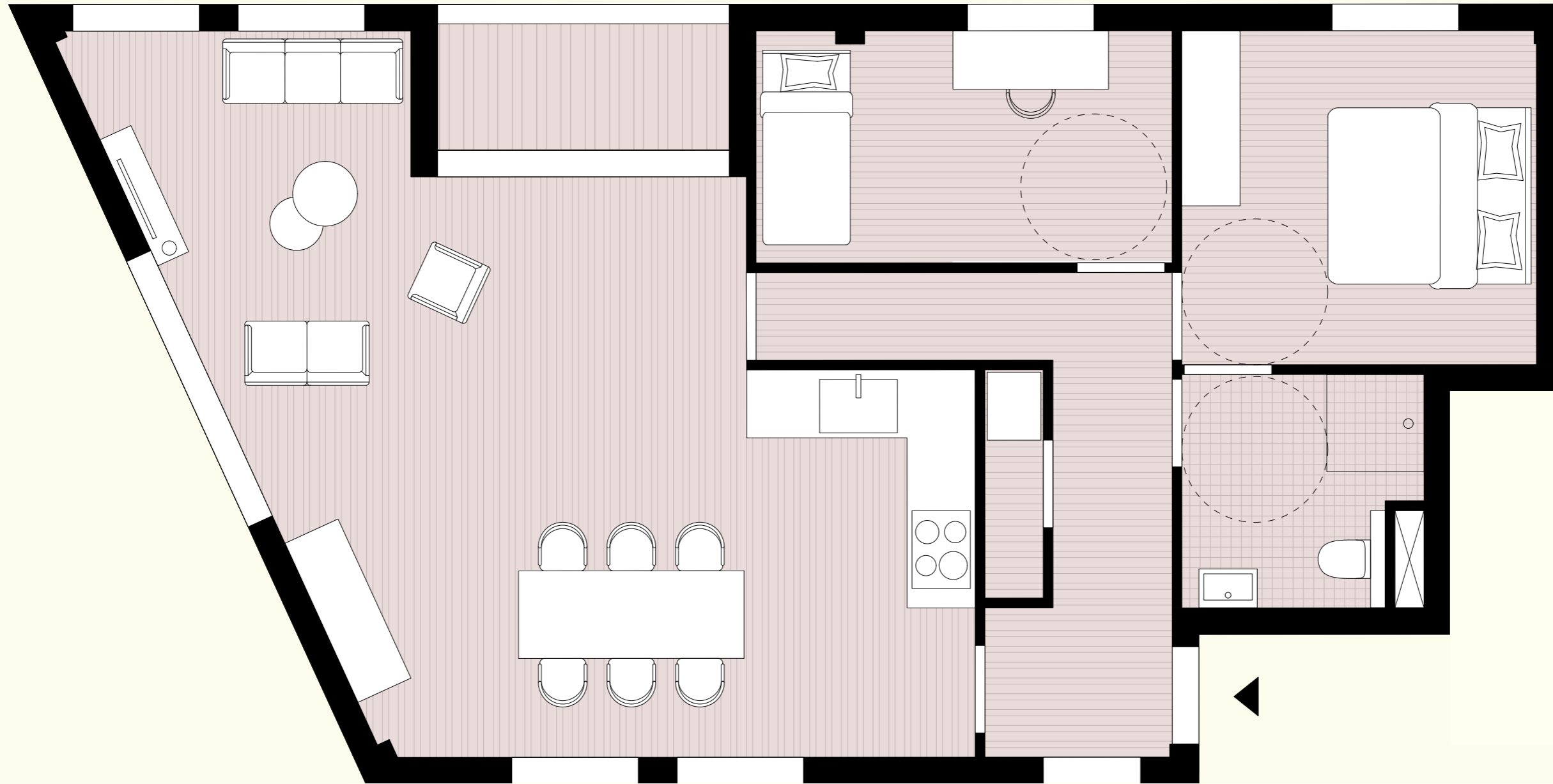
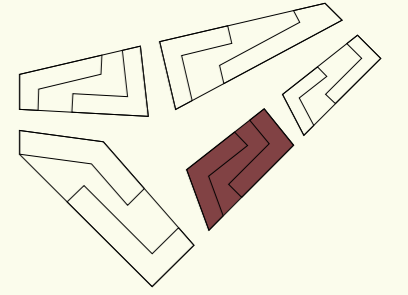

Apartment 93 m²

Scale 1:50

Floor plans Building A

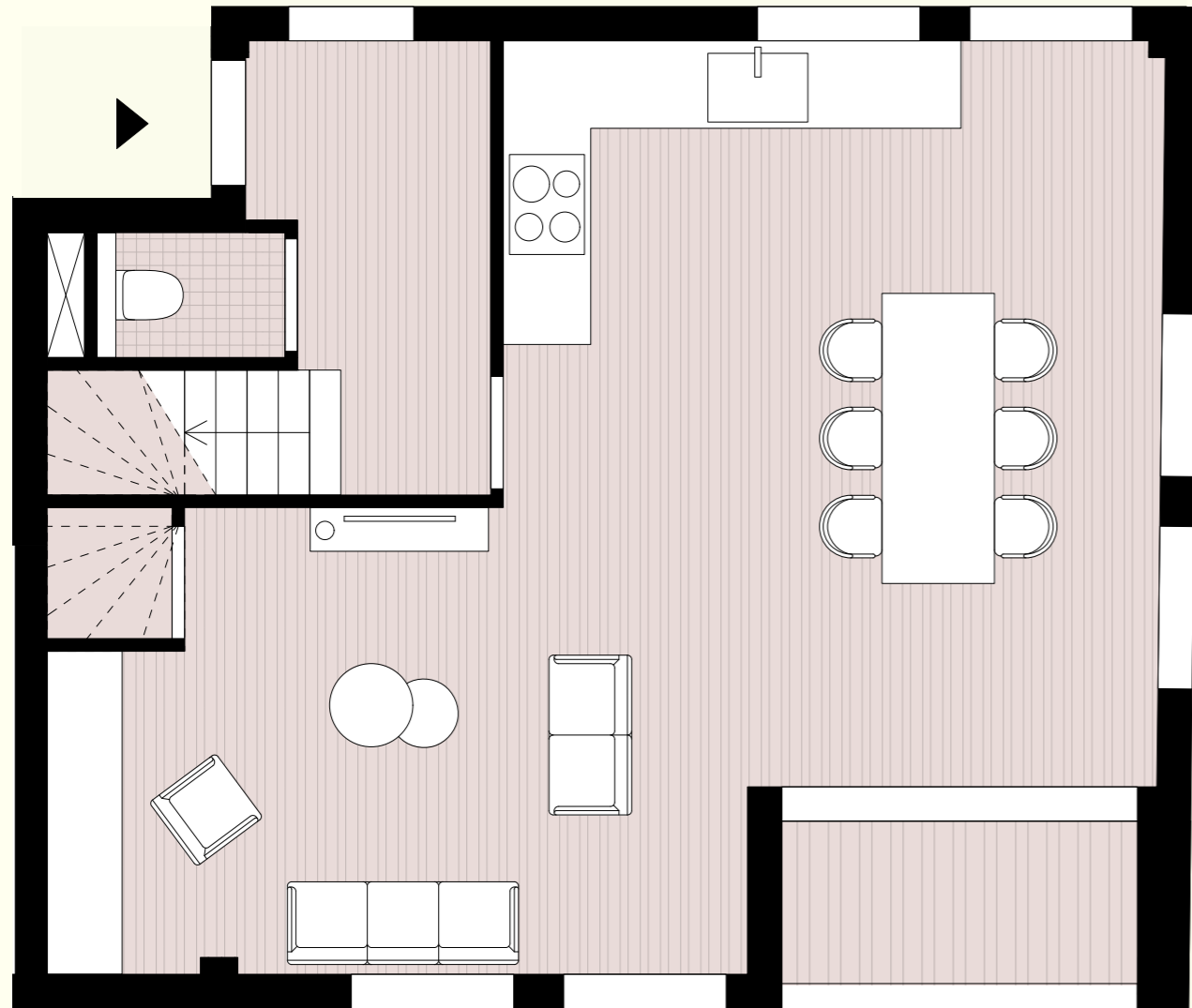
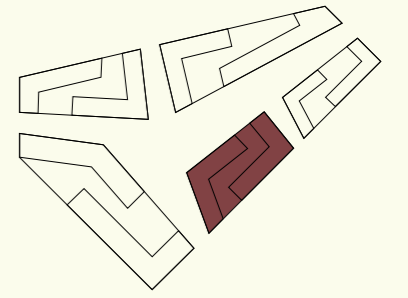

Maisonette 128 m²

Scale 1:50
(Scaled to fit)

Floor plans Building B

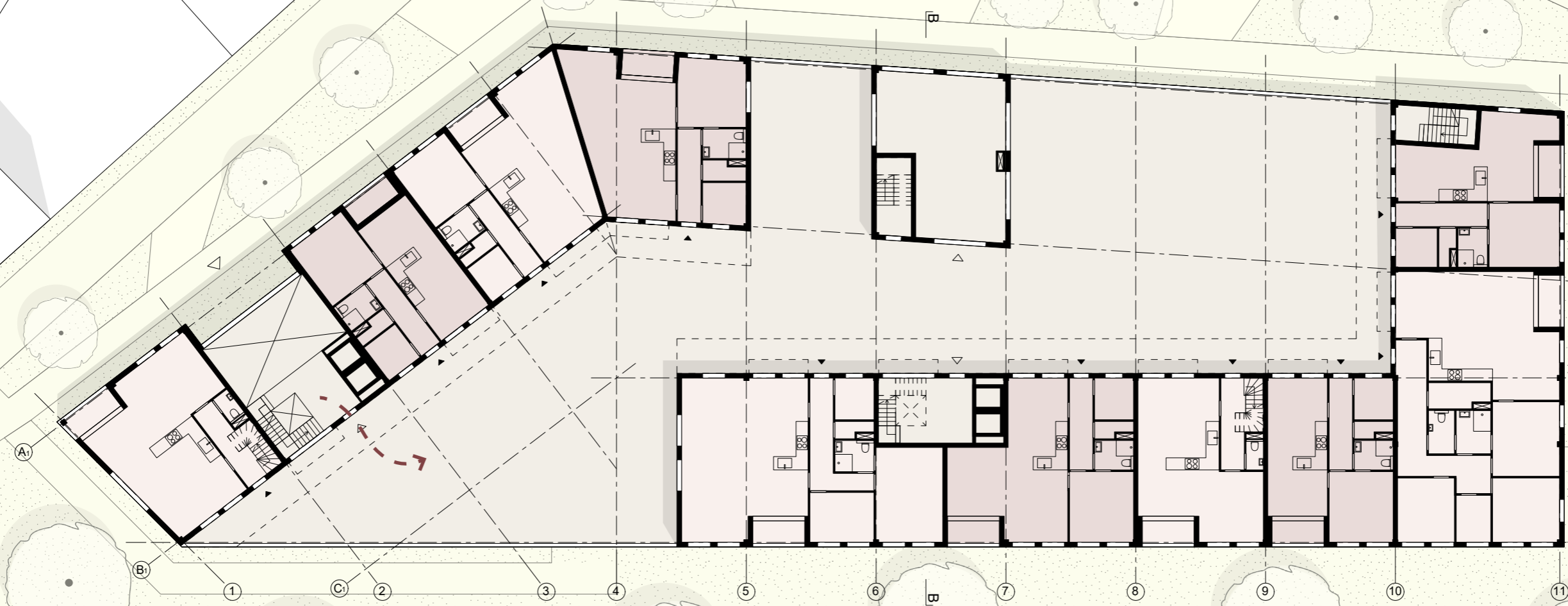

First floor
Scale 1:200
(Scaled to fit)



Floor plans Building B



First floor
Scale 1:200
(Scaled to fit)

Floor plans Building B

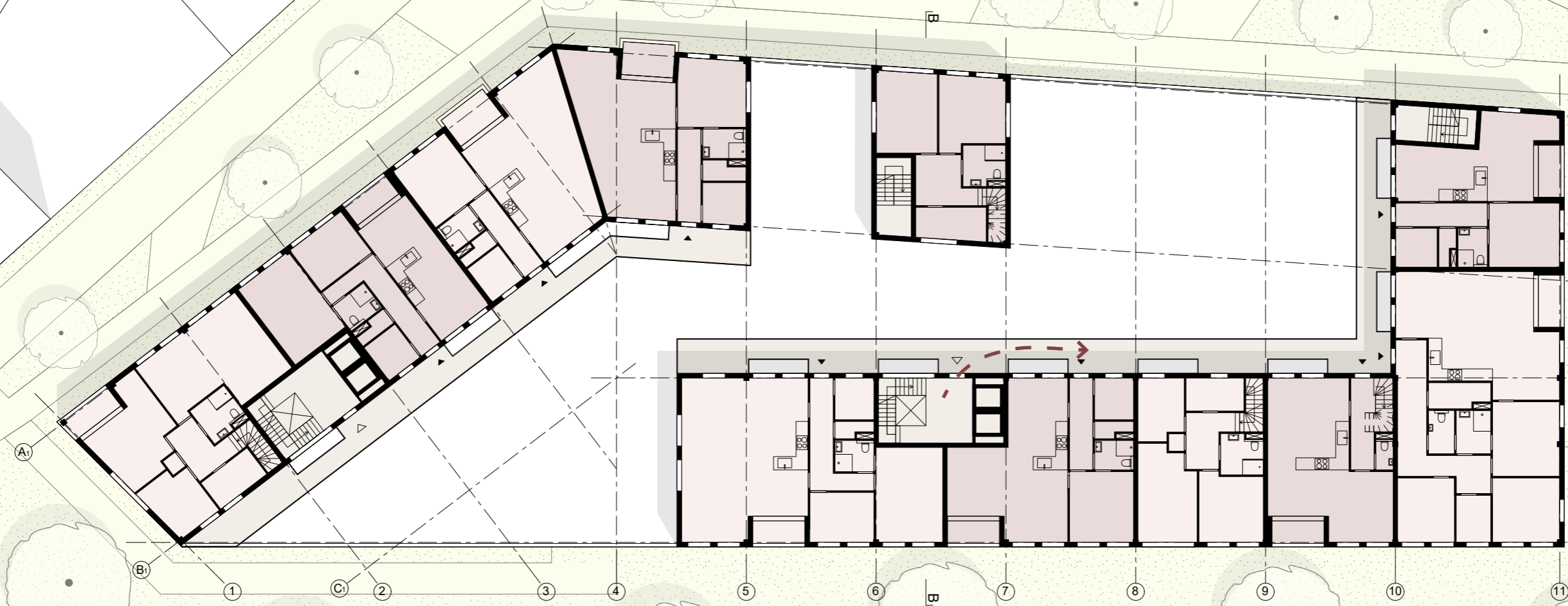

Second floor

Scale 1:200
(Scaled to fit)

Floor plans Building B

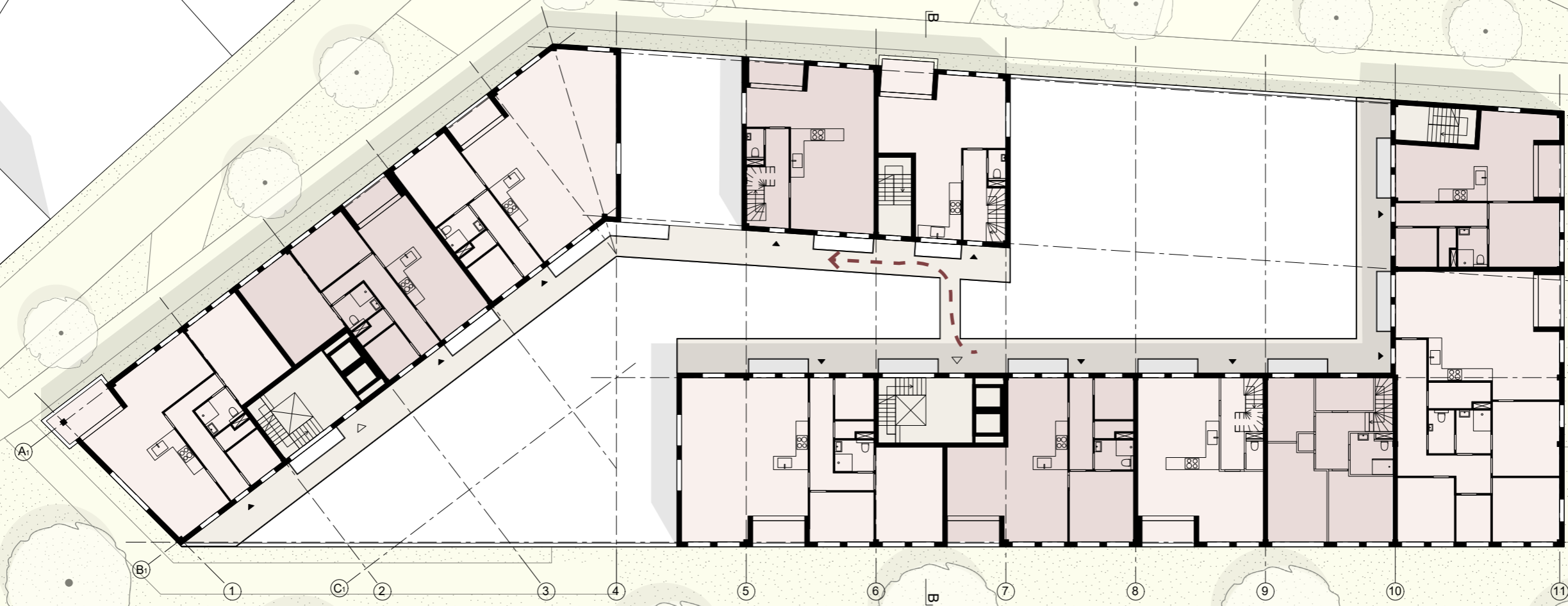

Third floor
Scale 1:200
(Scaled to fit)

Floor plans Building B

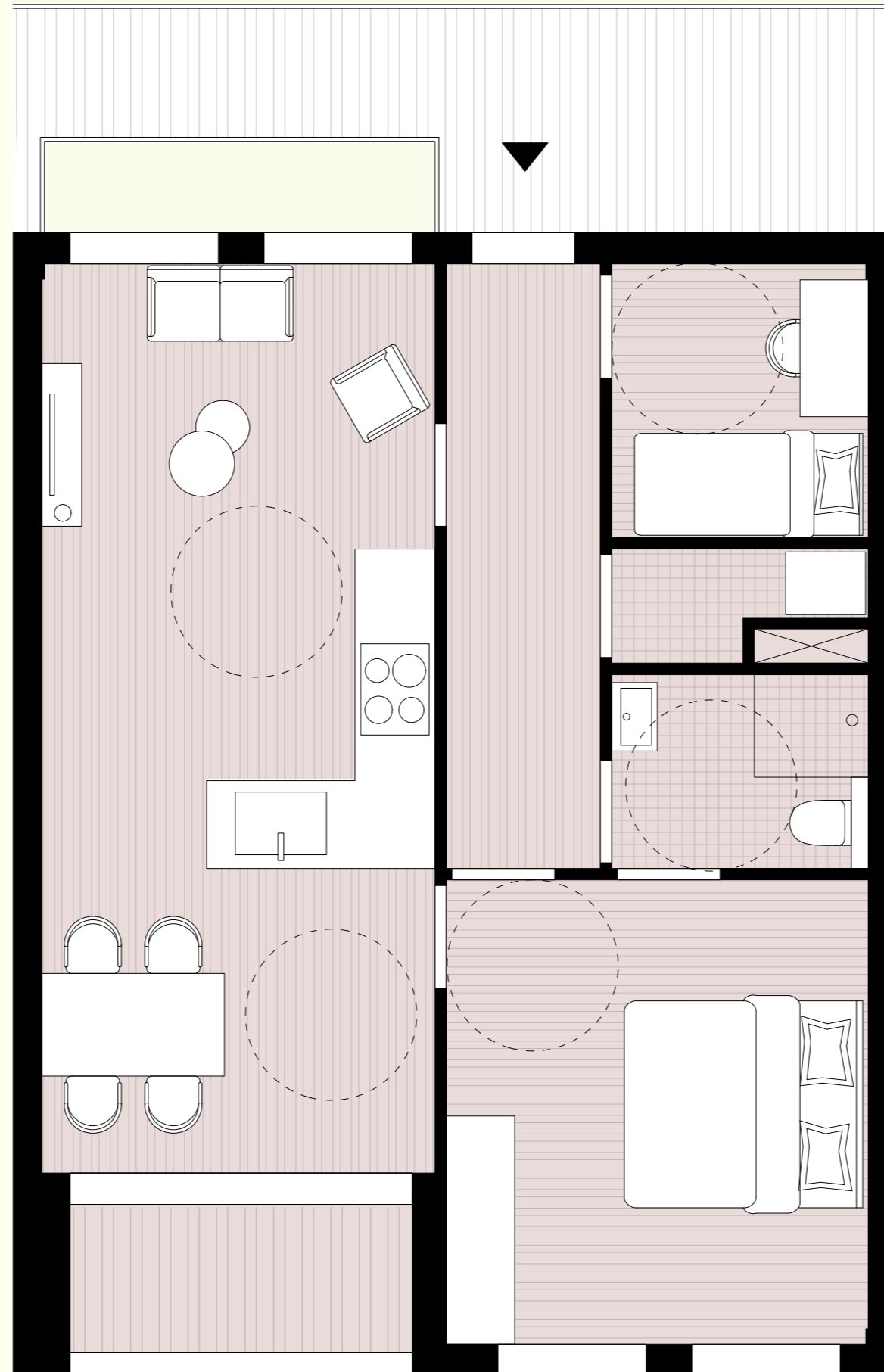
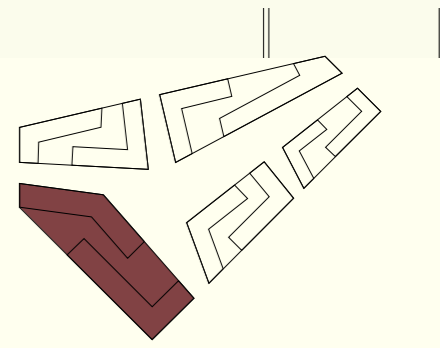

Apartment 70m²

⌚ Scale 1:50

Floor plans Building B

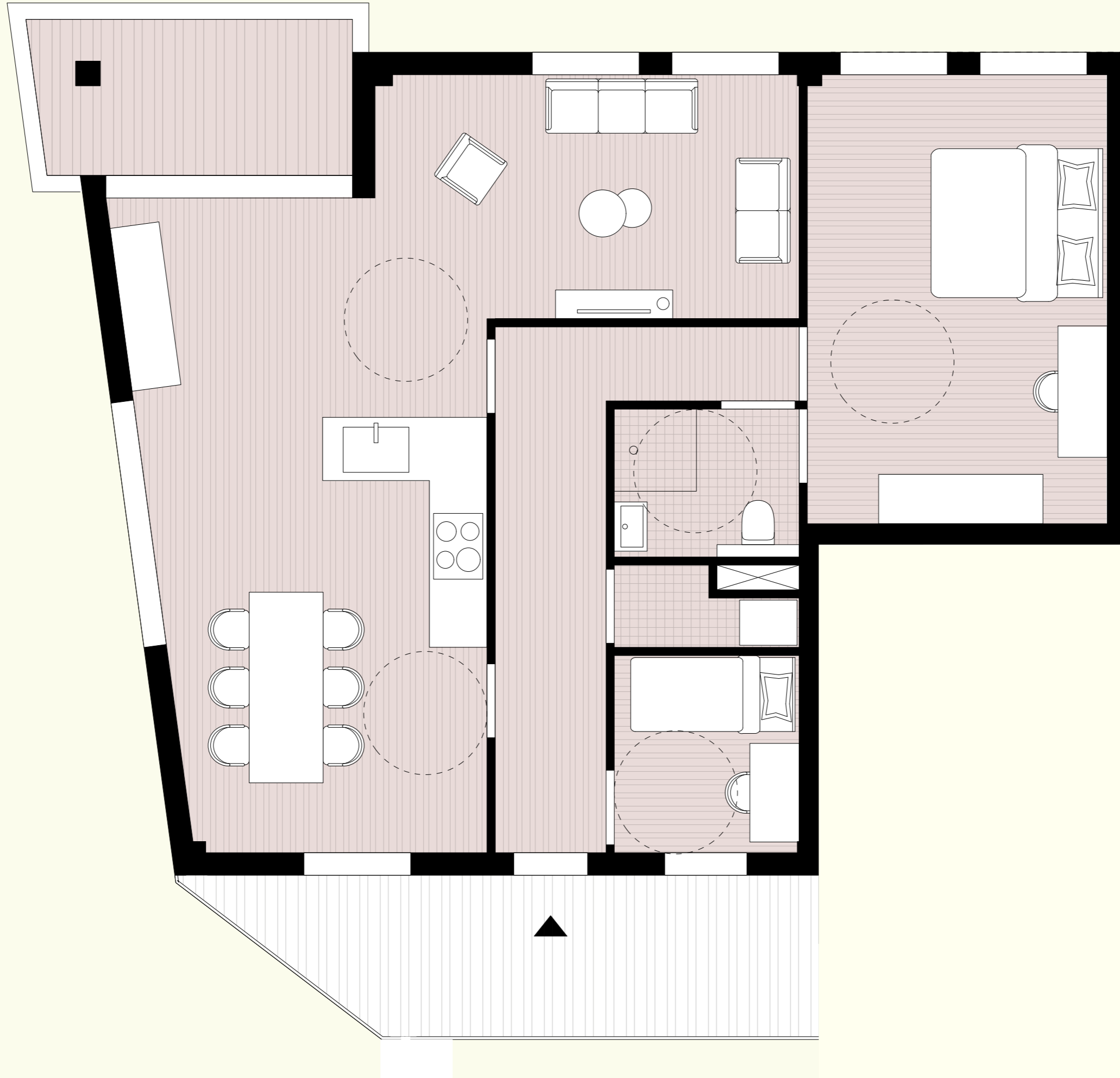
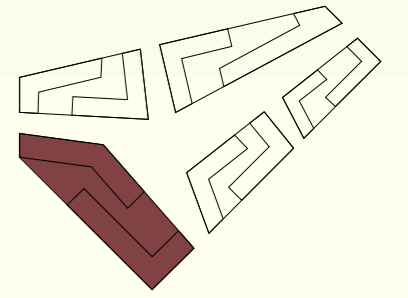

Apartment 95 m²

🕒 Scale 1:50

Floor plans Building B

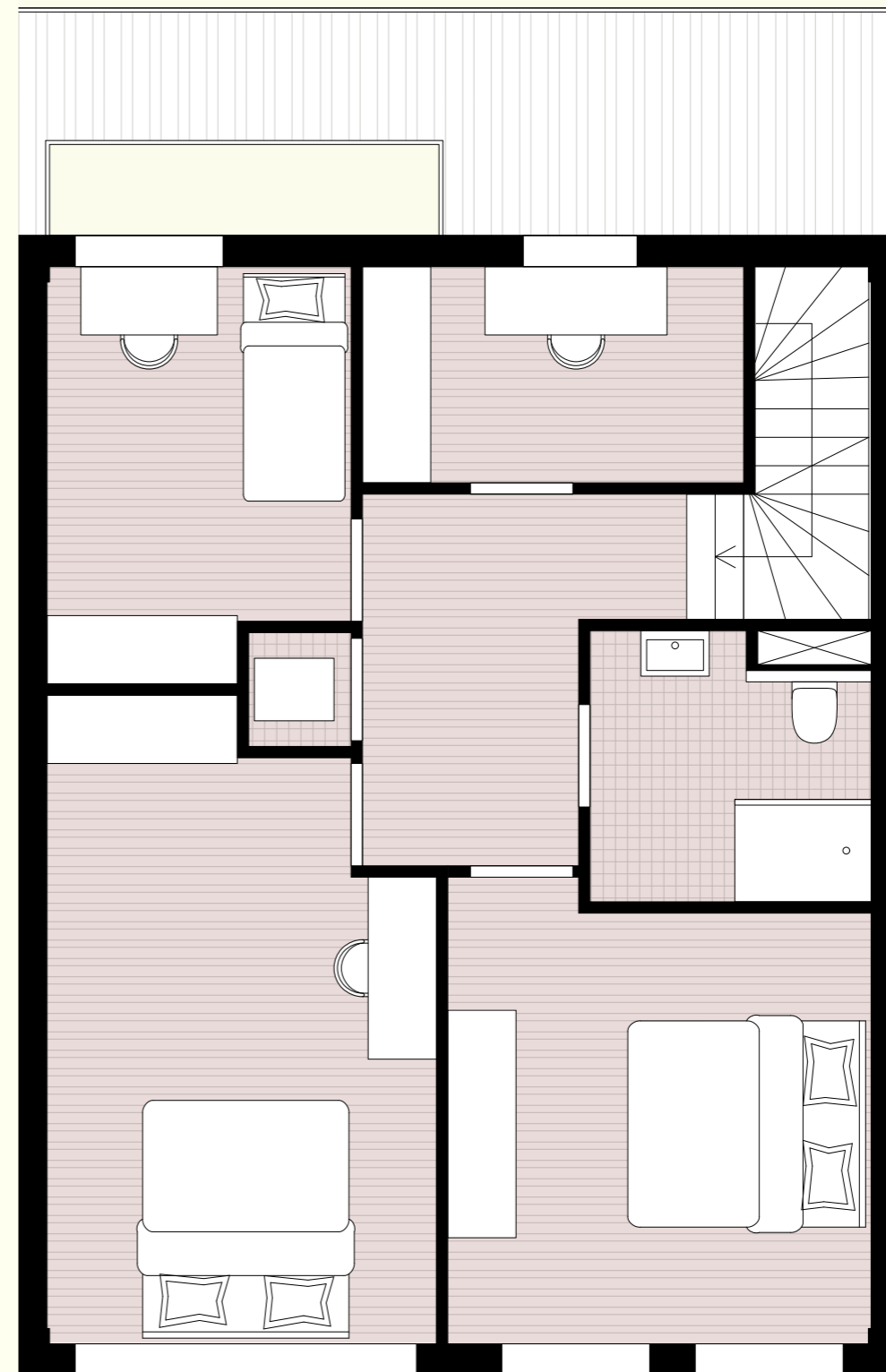
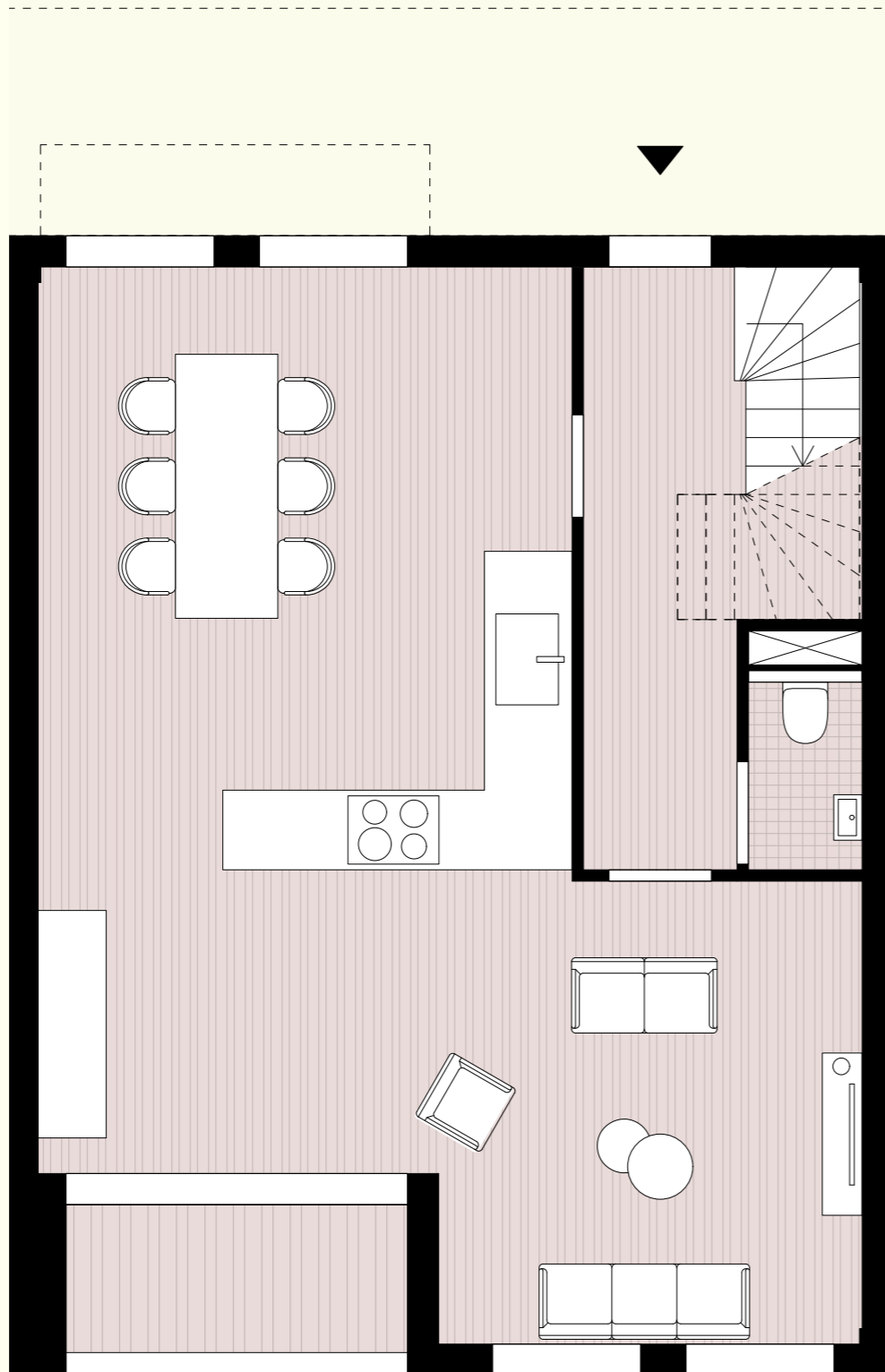
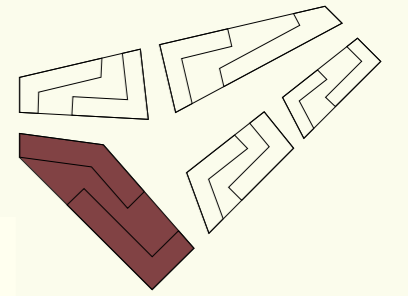

Maisonette 140 m²

⌚ Scale 1:50
(Scaled to fit)

The common

The common

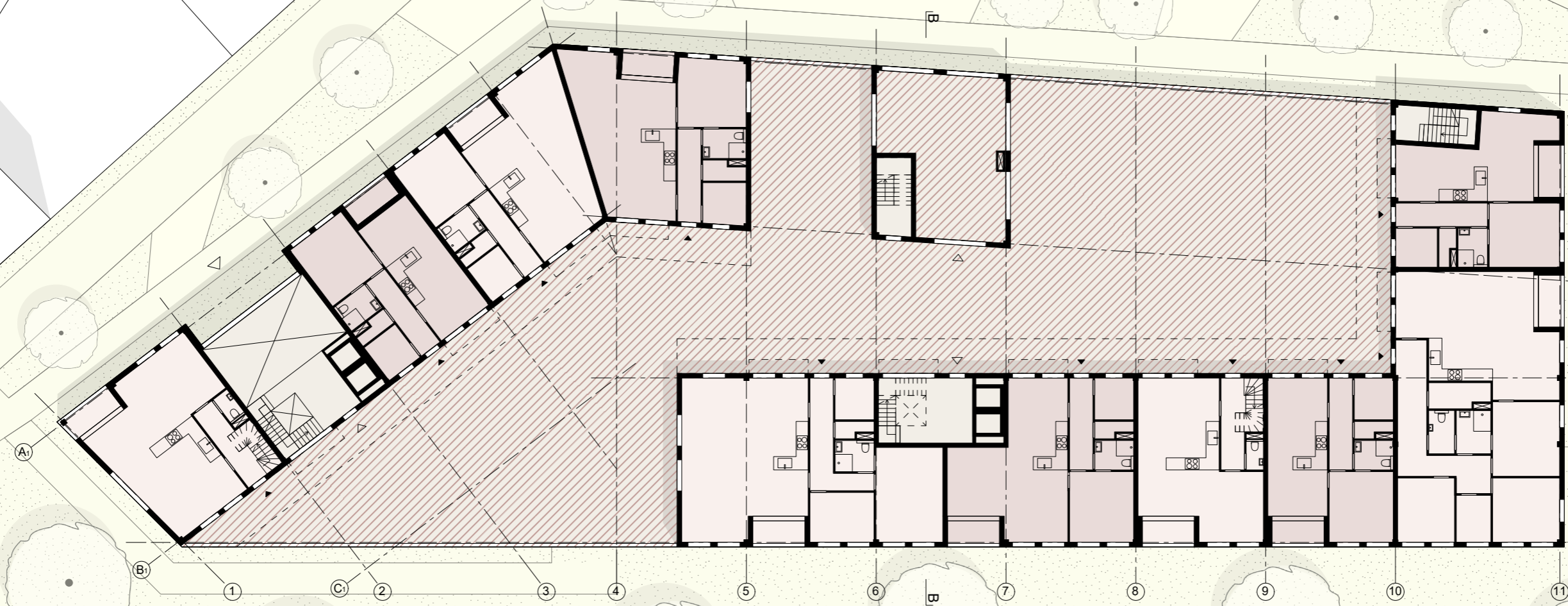
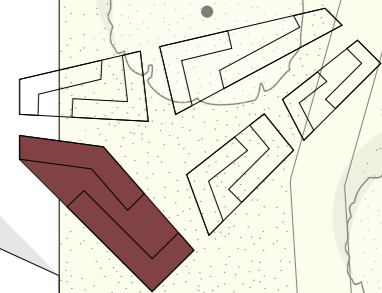

First floor

Scale 1:200
(Scaled to fit)



Open common

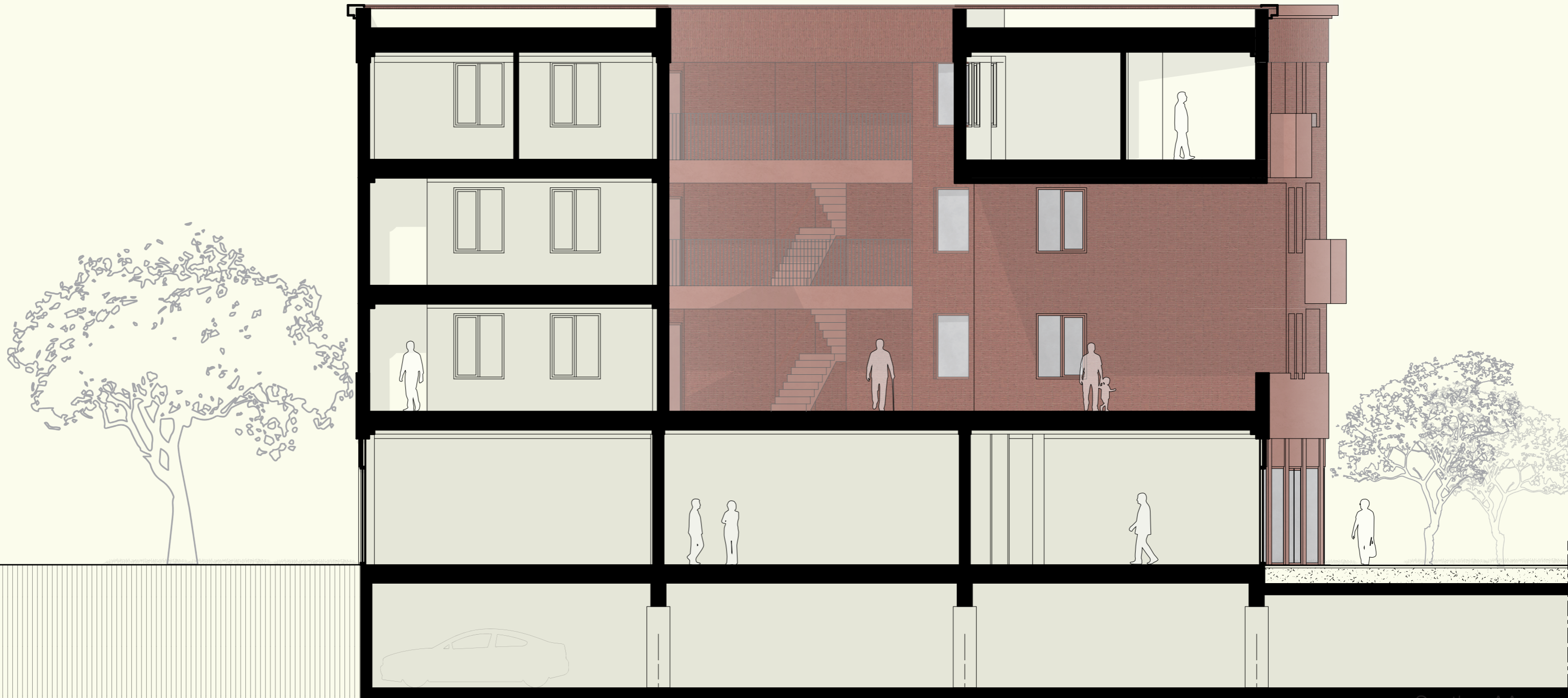
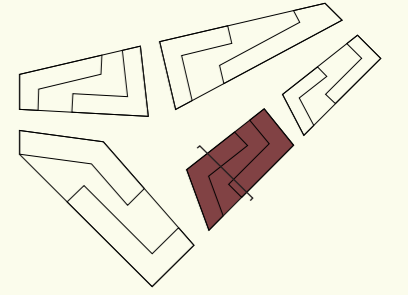

D

C

B

A

Section AA

Scale 1:100



Flexible structure

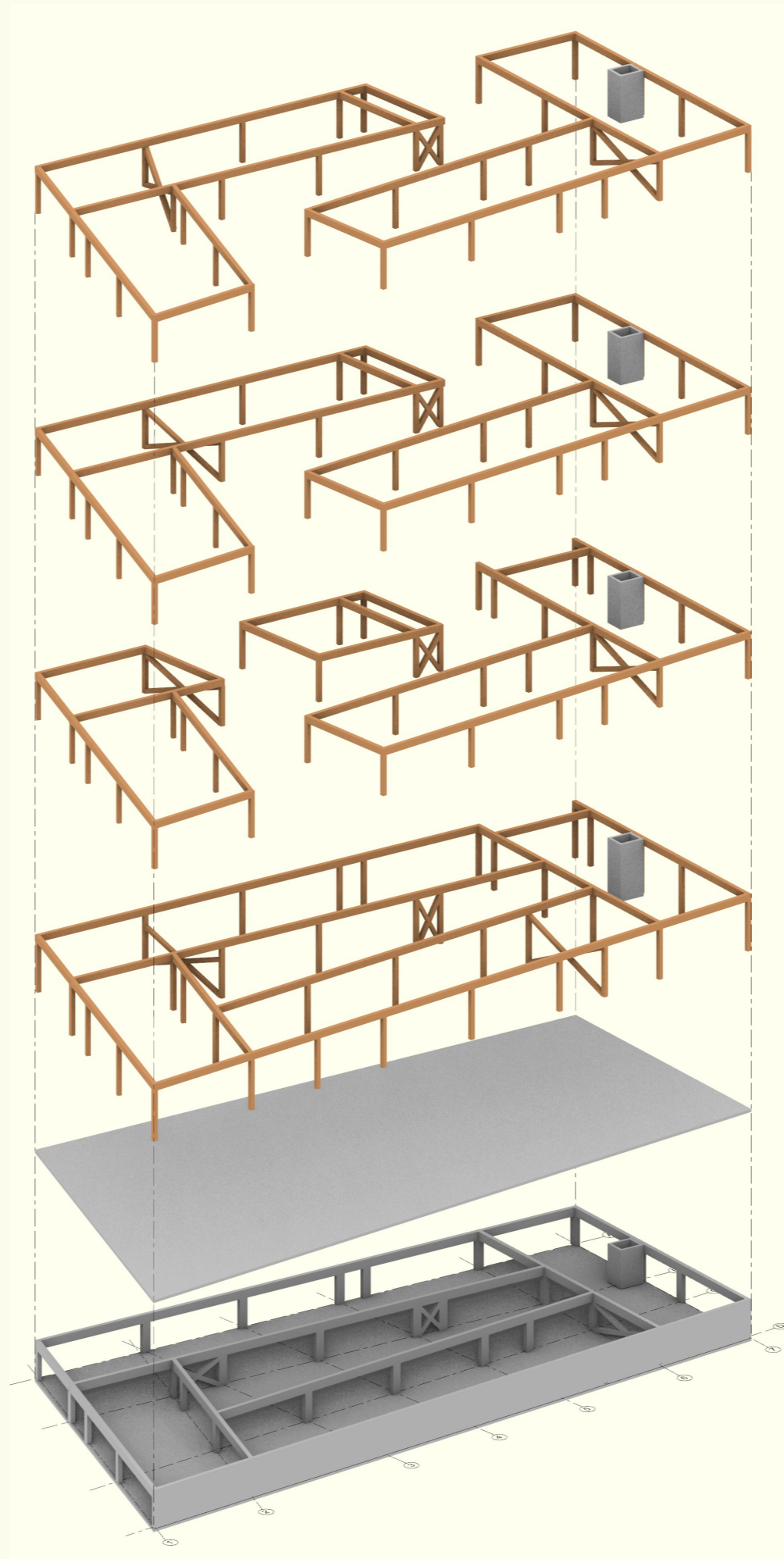
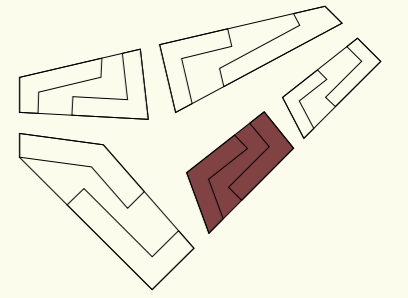

Facade design

Outer facade

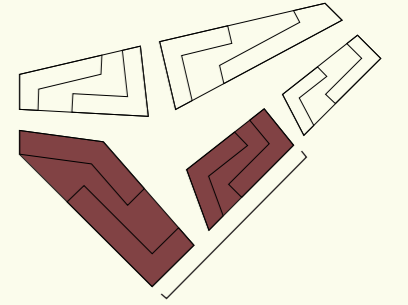

Southeast facade

Scale 1:200
(Scaled to fit)

Green street facade

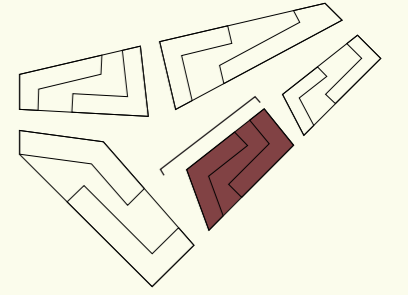

Northwest facade

Scale 1:200

Details

Facade fragment

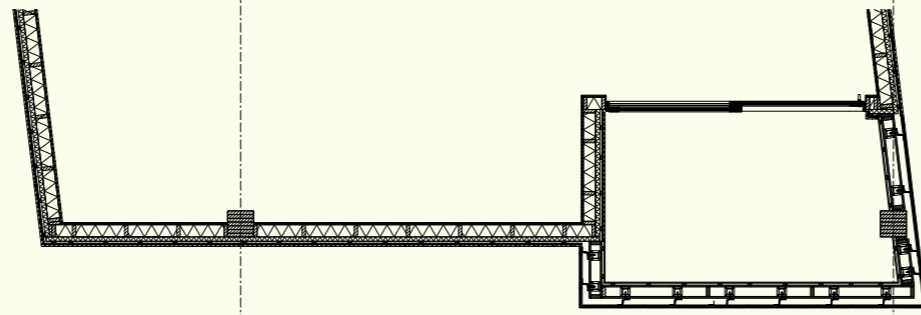
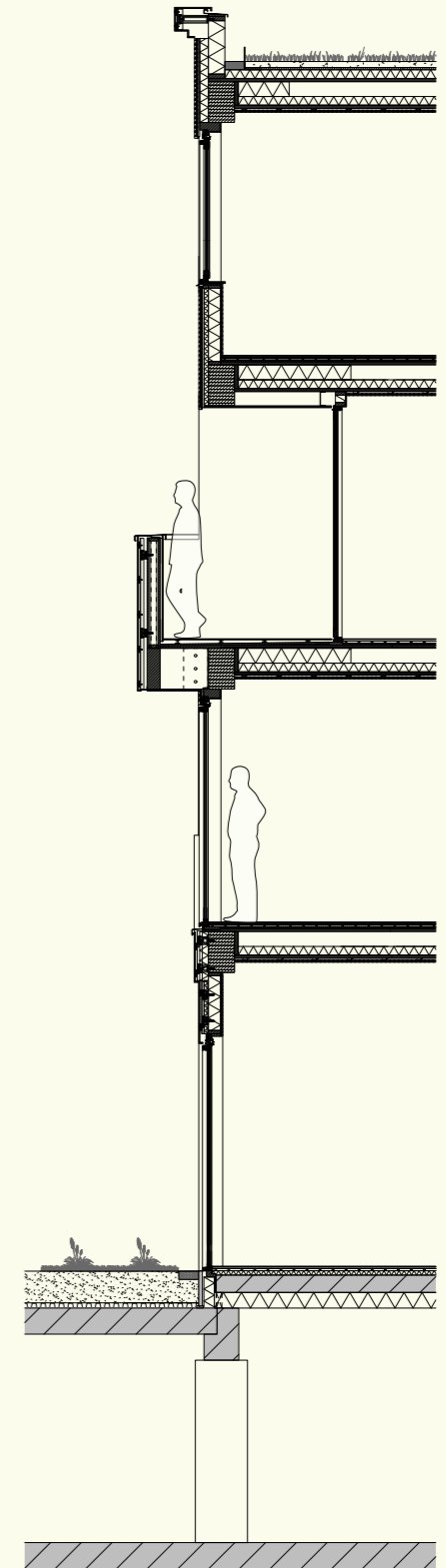

5

4

North west facade

Scale 1:20
(Scaled to fit)

Balcony

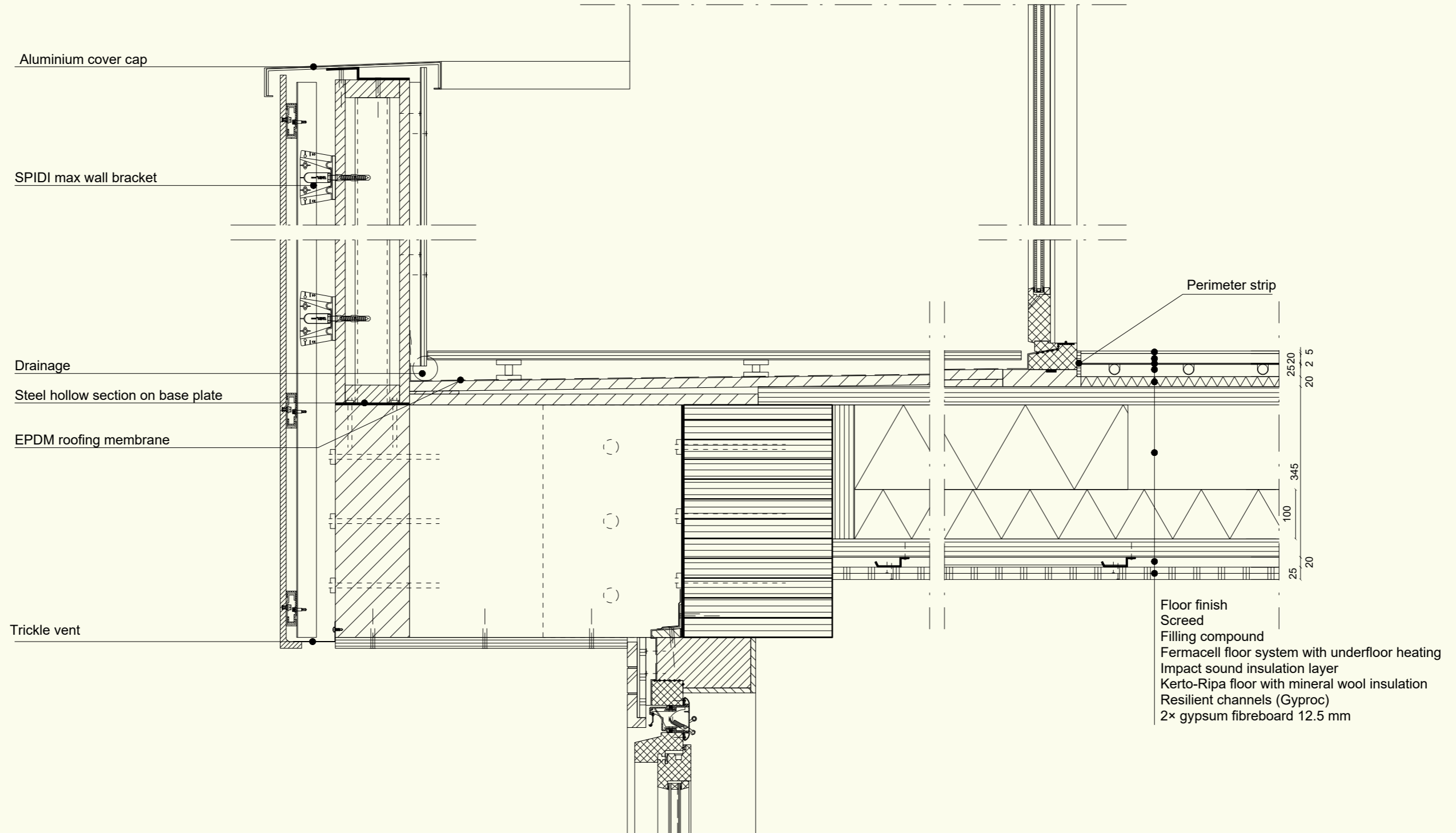

Detail balcony

Scale 1:5
(Scaled to fit)

Site section

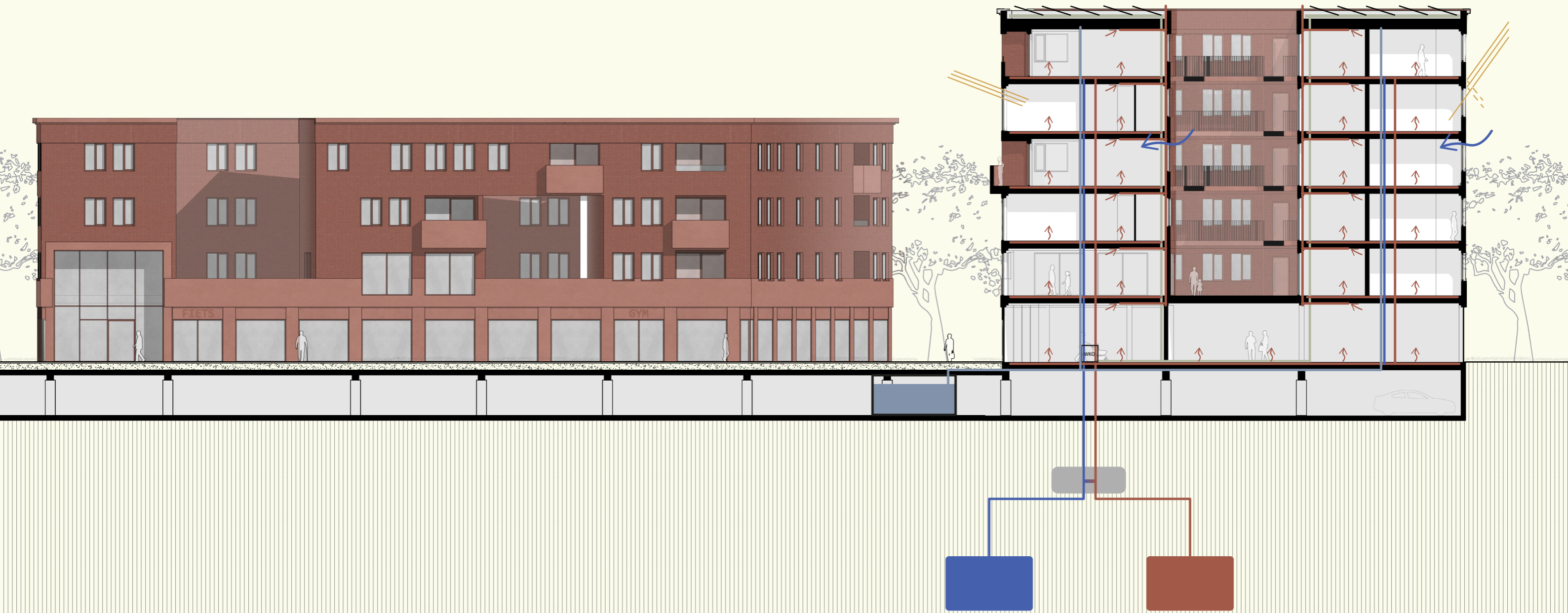
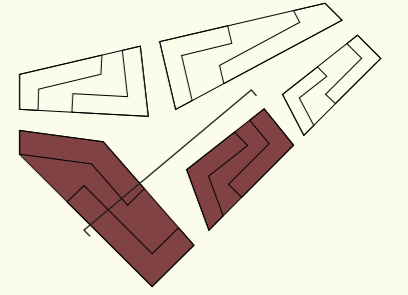

Scale 1:200
(Scaled to fit)

Flush and recessed window

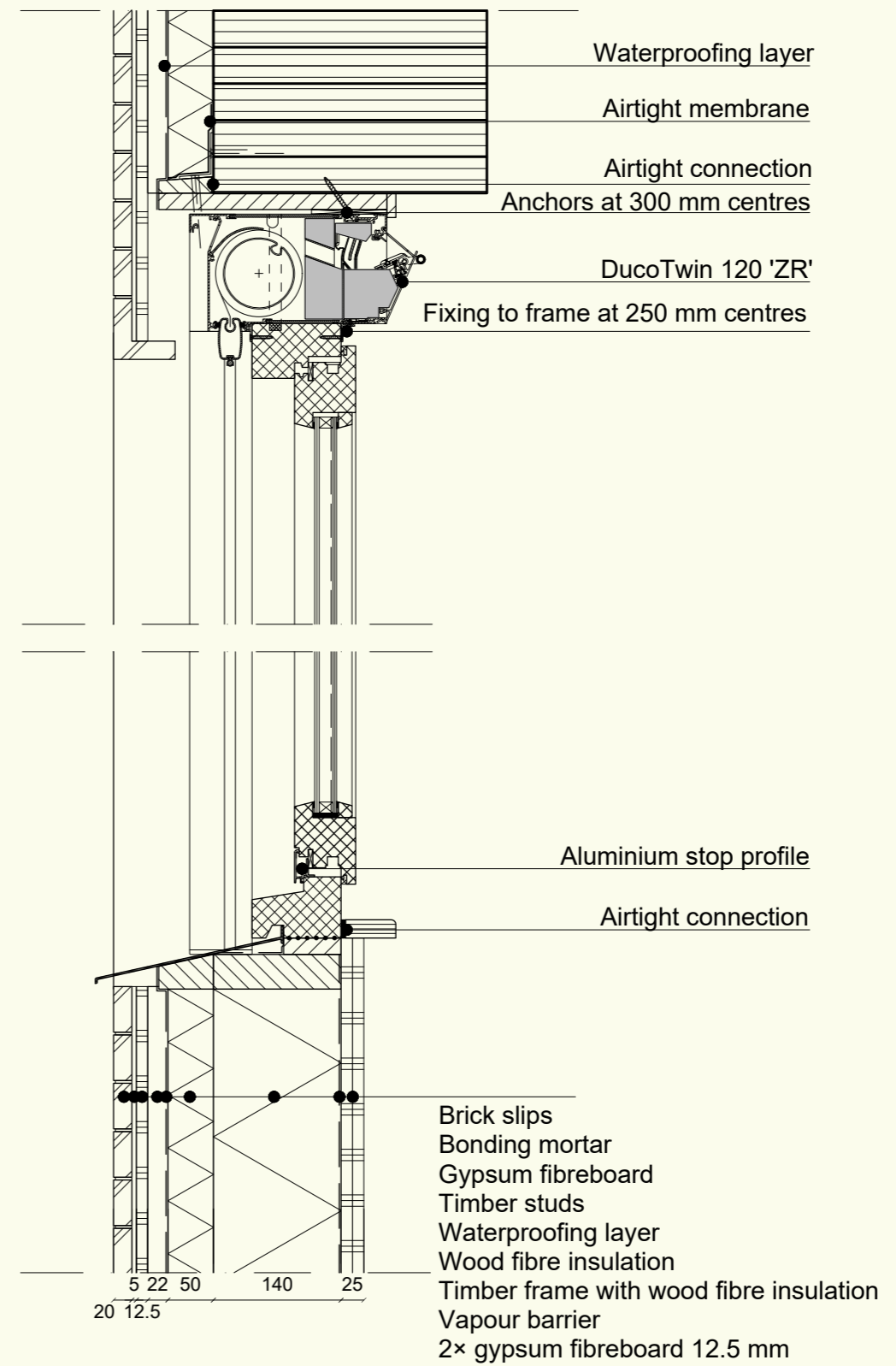
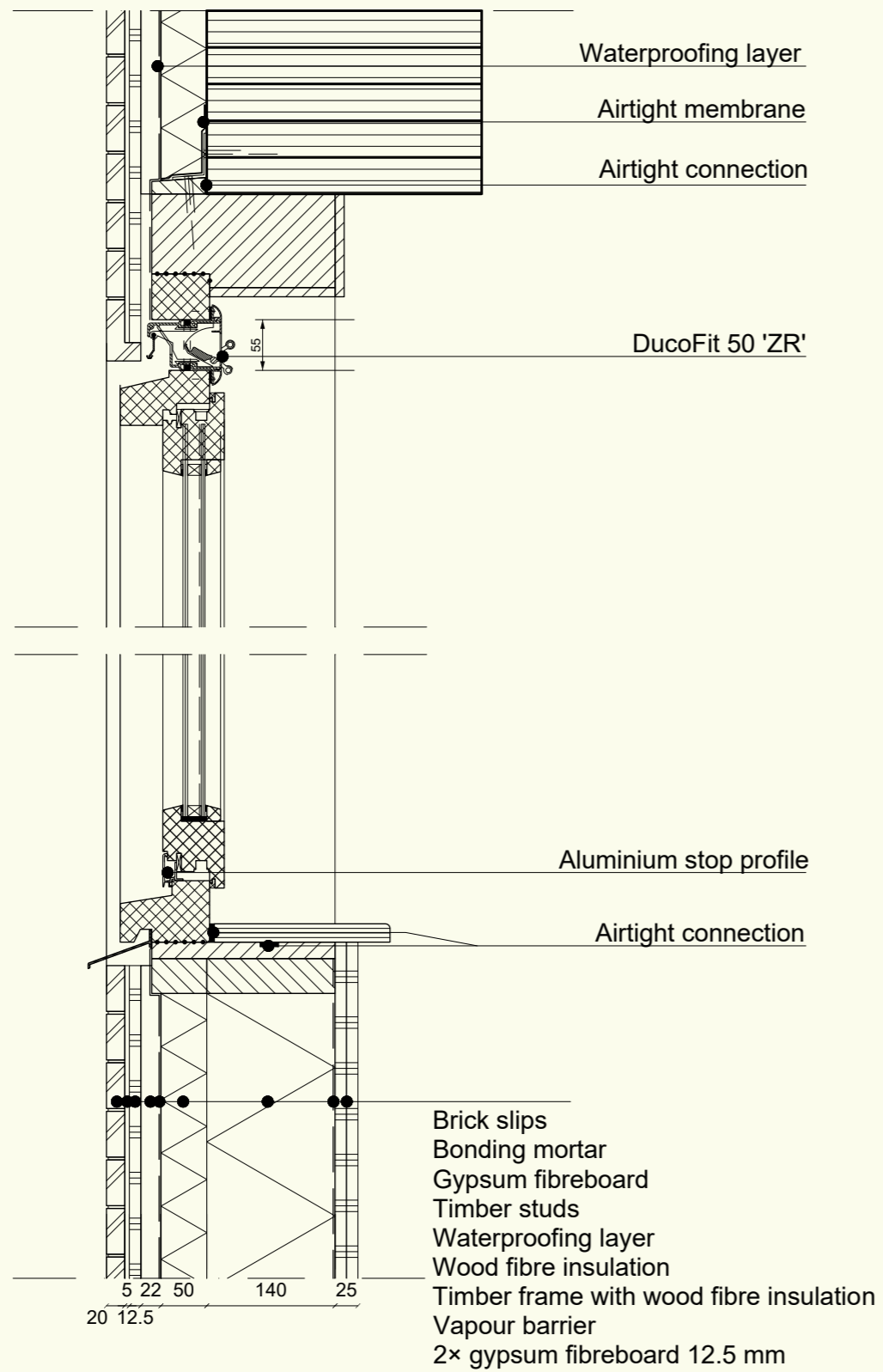

Detail flush and recessed window

Underground parking

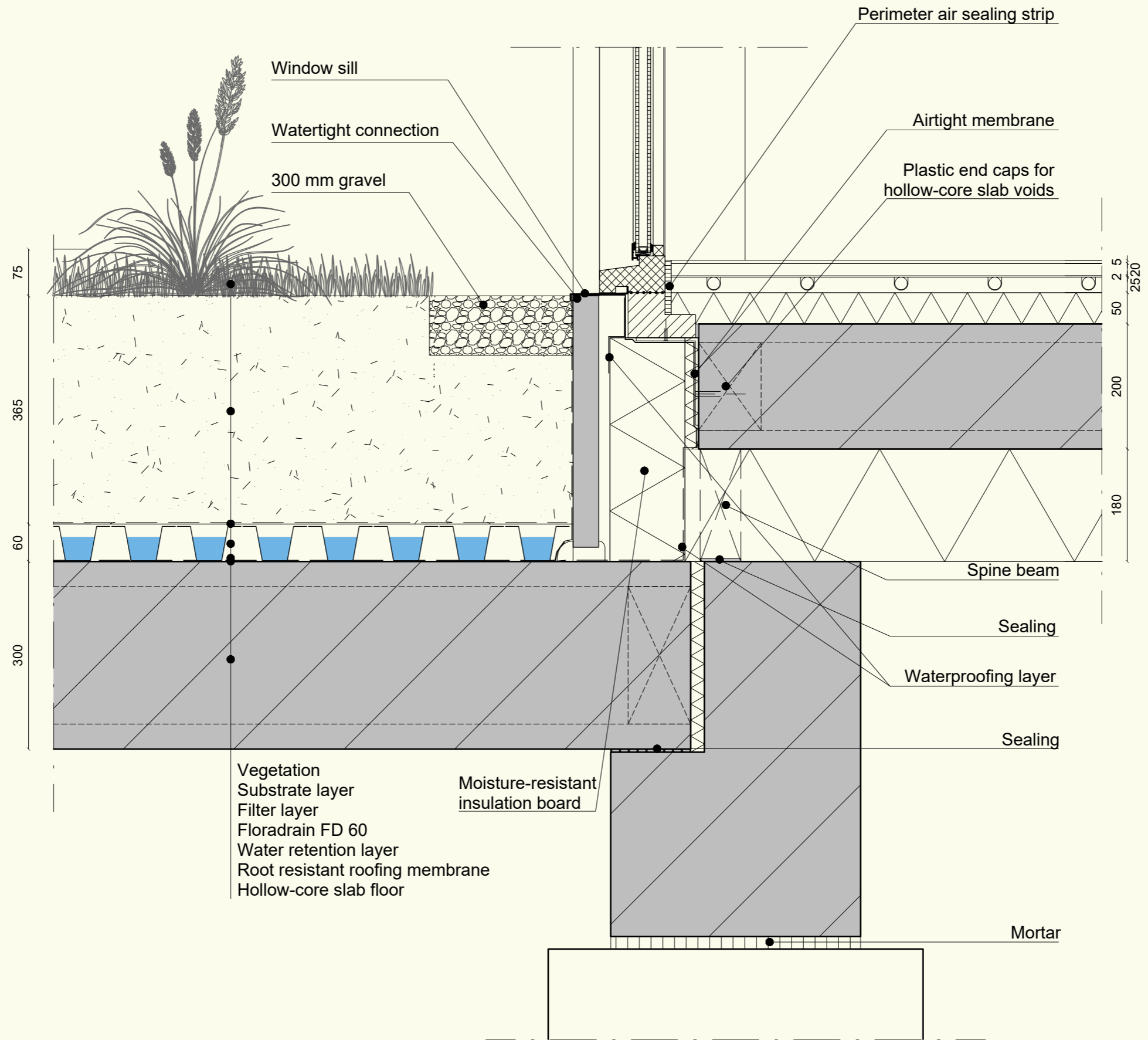

Detail foundation

Scale 1:5
(Scaled to fit)

Conclusion

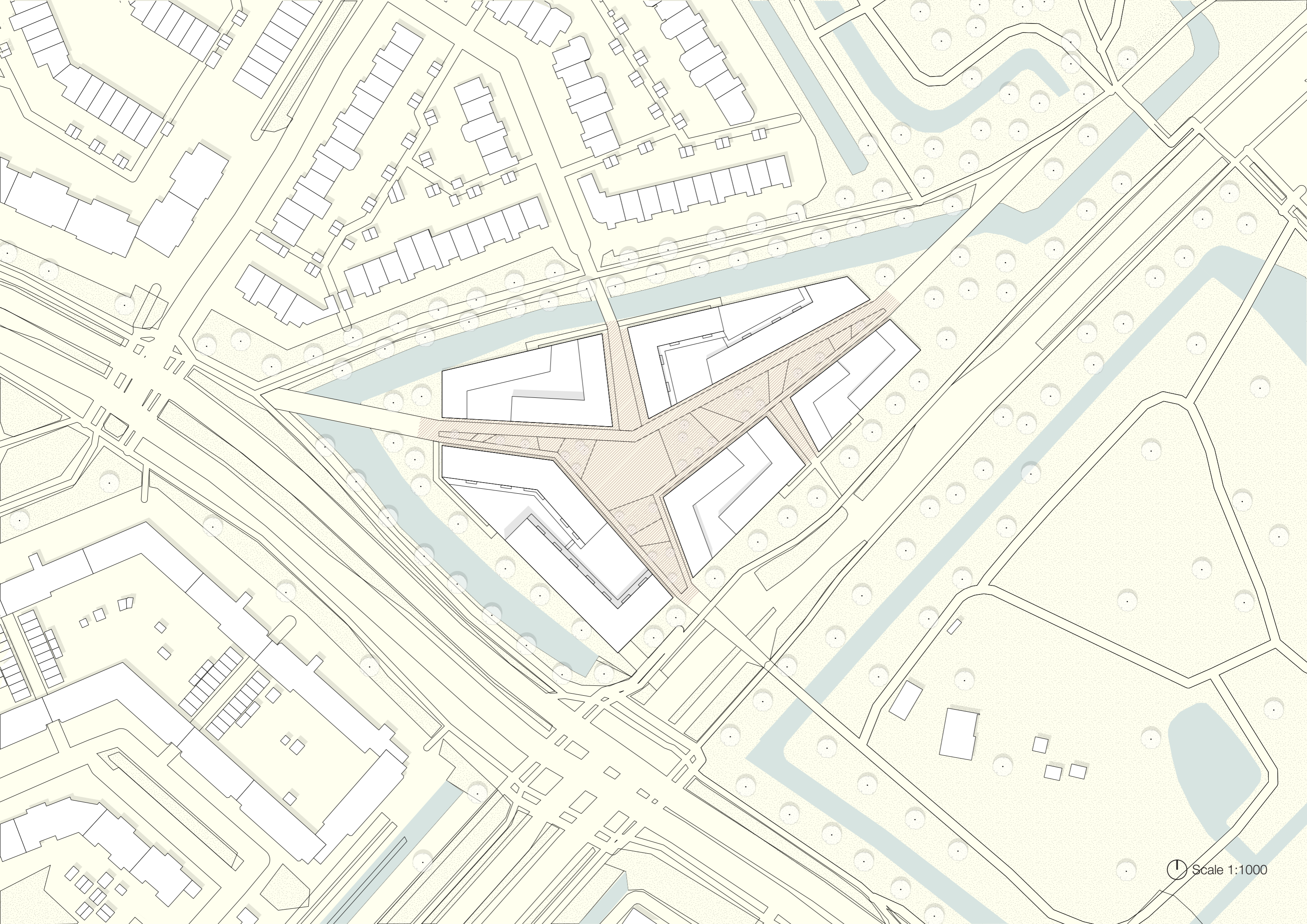

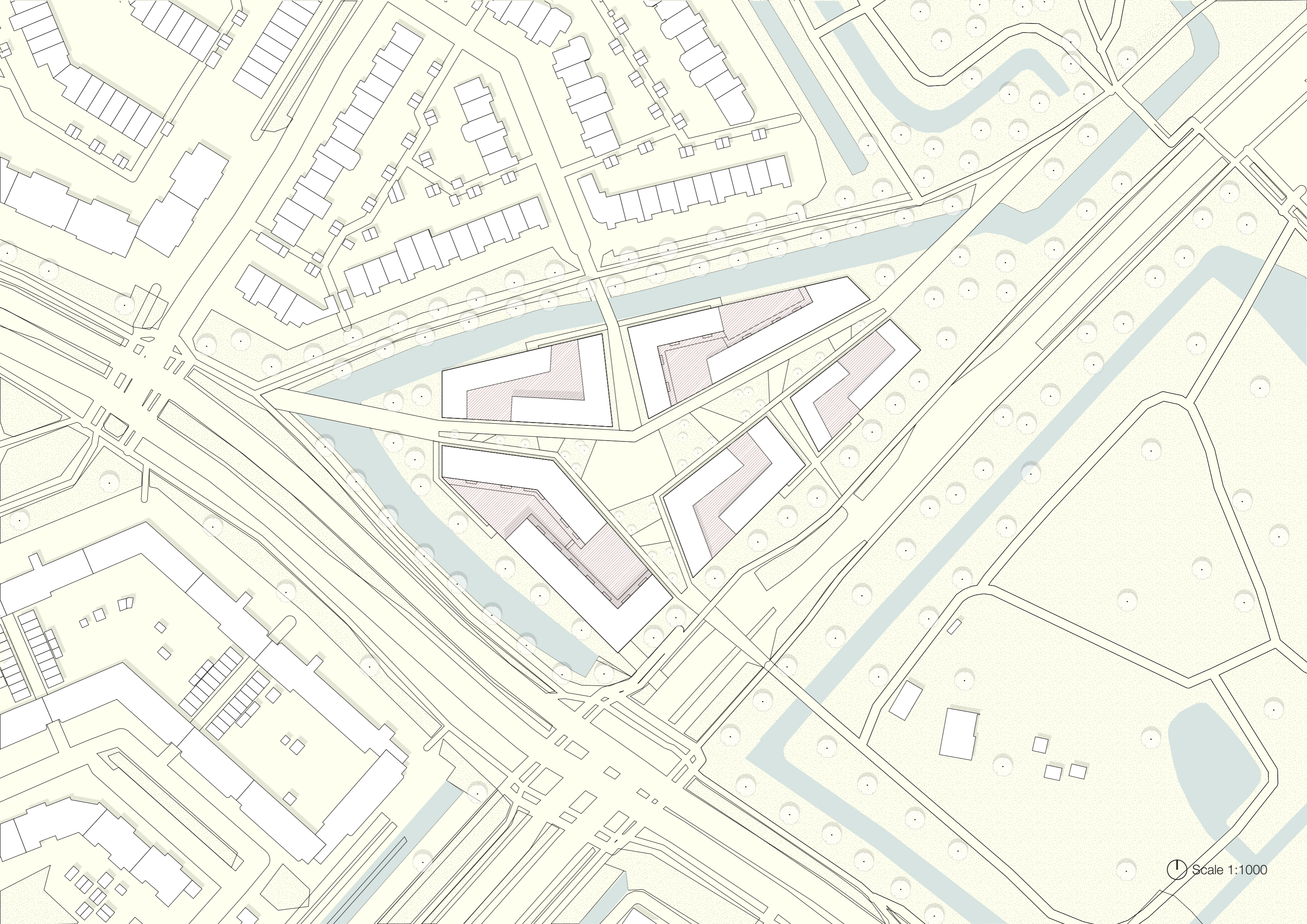



The Commons