

## Adaptive optics plug-and-play setup for high-resolution microscopes with multi-actuator adaptive lens

Quintavalla, M.; Pozzi, P.; Verhaegen, Michel; Bijlsma, Hielke; Verstraete, Hans; Bonora, S.

**DOI**

[10.1117/12.2290036](https://doi.org/10.1117/12.2290036)

**Publication date**

2018

**Document Version**

Final published version

**Published in**

Proceedings of SPIE

**Citation (APA)**

Quintavalla, M., Pozzi, P., Verhaegen, M., Bijlsma, H., Verstraete, H., & Bonora, S. (2018). Adaptive optics plug-and-play setup for high-resolution microscopes with multi-actuator adaptive lens. In A. Periasamy, P. T. C. So, K. König, & X. S. Xie (Eds.), *Proceedings of SPIE: Multiphoton Microscopy in the Biomedical Sciences XVIII* (Vol. 10498). Article 104981X (Proceedings SPIE; Vol. 10498). SPIE.  
<https://doi.org/10.1117/12.2290036>

**Important note**

To cite this publication, please use the final published version (if applicable).  
Please check the document version above.

**Copyright**

Other than for strictly personal use, it is not permitted to download, forward or distribute the text or part of it, without the consent of the author(s) and/or copyright holder(s), unless the work is under an open content license such as Creative Commons.

**Takedown policy**

Please contact us and provide details if you believe this document breaches copyrights.  
We will remove access to the work immediately and investigate your claim.

# PROCEEDINGS OF SPIE

[SPIDigitalLibrary.org/conference-proceedings-of-spie](https://spiedigitallibrary.org/conference-proceedings-of-spie)

## Adaptive optics plug-and-play setup for high-resolution microscopes with multi-actuator adaptive lens

M. Quintavalla, P. Pozzi, Michelle Verhaegen, Hielke Bijlsma, Hans Verstraete, et al.

M. Quintavalla, P. Pozzi, Michelle Verhaegen, Hielke Bijlsma, Hans Verstraete, S. Bonora, "Adaptive optics plug-and-play setup for high-resolution microscopes with multi-actuator adaptive lens," Proc. SPIE 10498, Multiphoton Microscopy in the Biomedical Sciences XVIII, 104981X (23 February 2018); doi: 10.1117/12.2290036

**SPIE.**

Event: SPIE BiOS, 2018, San Francisco, California, United States

# Adaptive optics plug-and-play setup for high-resolution microscopes with multi-actuator adaptive lens

M. Quintavalla\*<sup>a</sup>, P. Pozzi<sup>b</sup>, Michelle Verhaegen<sup>b</sup>, Hielke Bijlsma<sup>b</sup>, Hans Verstraete<sup>b</sup> and S. Bonora<sup>a</sup>  
<sup>a</sup> CNR-Institute for Photonics and Nanotechnology, via Trasea 7, 35131, Padova, Italy ;  
<sup>b</sup> Delft Center for Systems and Control, TU Delft, Mekelweg 2, Delft, Netherlands

## ABSTRACT

Adaptive Optics (AO) has revealed as a very promising technique for high-resolution microscopy, where the presence of optical aberrations can easily compromise the image quality. Typical AO systems however, are almost impossible to implement on commercial microscopes. We propose a simple approach by using a Multi-actuator Adaptive Lens (MAL) that can be inserted right after the objective and works in conjunction with an image optimization software allowing for a wavefront sensorless correction. We presented the results obtained on several commercial microscopes among which a confocal microscope, a fluorescence microscope, a light sheet microscope and a multiphoton microscope.

**Keywords:** Adaptive optics, Adaptive lens, High-resolution microscopy, optimization

## 1. INTRODUCTION

High resolution microscopy techniques, where high numerical aperture objectives are used, can be severely affected by optical aberrations coming both from the sample, such as in the case of thick samples, and from the microscope optics.

Adaptive Optics (AO) has proven to be an effective way to compensate for these aberrations and several papers have discussed its use and the major breakthrough that were possible thanks to it<sup>1,2</sup>.

Despite these interesting results, the use of AO in commercial microscopes is still in an embryonal stage. The literature experiments in fact, have been performed on custom microscopes that were built on purpose and the application of AO to commercial microscope requires such important modifications to the hardware and software to make it practically impossible.

In this paper, we discuss the possibility to implement AO in commercial microscopes in a simple and effective way by using a refractive optical element mounted at the back of the objective and a standalone control software that provides a sensorless wavefront optimization based on the acquired images.

## 2. MULTI-ACTUATOR ADAPTIVE LENS

Since AO is typically performed by using deformable mirrors or spatial light modulators that reflect or refract light varying the direction of propagation, it is almost impossible to implement such devices in commercial microscopes without revising the entire optical setup. The recent realization of Multi-actuator Adaptive Lenses (MALs) at CNR-Institute for photonics and nanotechnology<sup>3</sup> of Padova, Italy however, allowed to overcome this limitation.

MALs are piezoelectric-based deformable lenses that can be directly inserted in the optical path without any deviation in the propagation direction. These devices are constituted by two thin glass windows upon which a piezoelectric ring with 9 actuators is mounted. The gap between the windows is filled with a liquid and the actuation of the 18 actuators (9 on the top window and 9 on the bottom window) allows for the generation (or correction) of arbitrary wavefronts.

\* [martino.quintavalla@pd.ifn.cnr.it](mailto:martino.quintavalla@pd.ifn.cnr.it)

Wavefront modulation performance can be evaluated as the MAL ability to generate Zernike polynomial wavefronts. These devices are capable of generating Zernike wavefronts up to the 4th order with amplitudes that are comparable to those obtained with deformable mirrors. An example of the first 15 Zernike polynomials generated by a 10 mm aperture MAL and a typical bimorph piezoelectric deformable mirror are reported in figure 1.

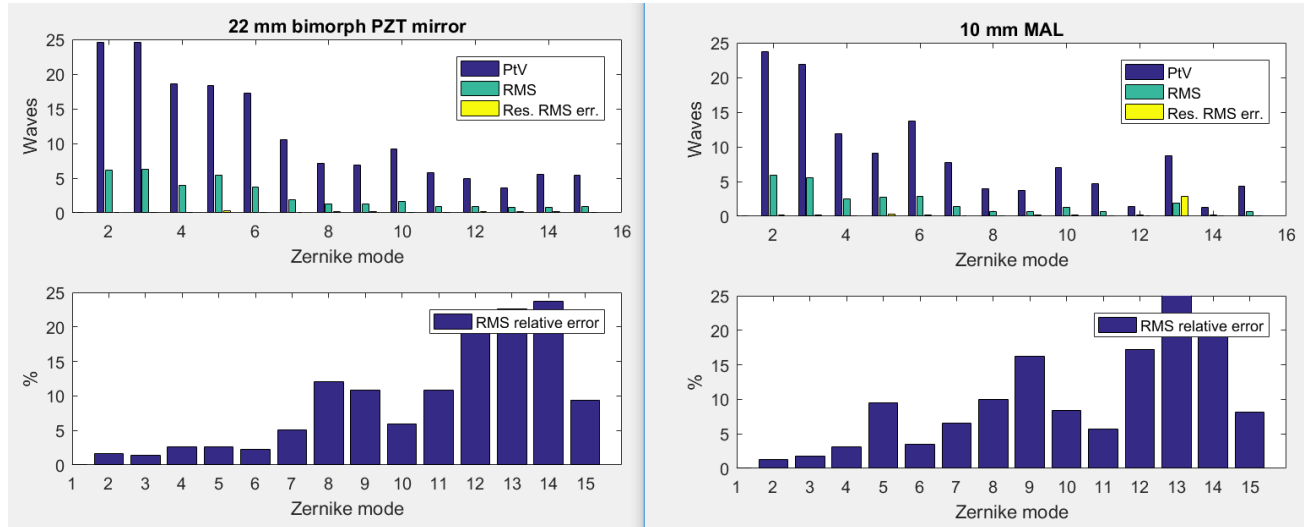

Figure 1. Closed loop Zernike modes generation comparison between a 22 mm PZT bimorph mirror and a 10 mm multiactuator adaptive lens.

Data were collected by controlling the MAL in a simple AO setup where a collimated beam passes through the adaptive lens and is then reimaged on a Shack Hartmann Wave Front Sensor (WFS). Zernike polynomials were generated by controlling the device in closed loop and amplitude was increased step by step until reaching the first actuators saturation. At this point, the Wavefront was recorded and the Zernike mode RMS and Peak to Valley amplitudes were extracted. The residual error was measured and compared to the Zernike mode amplitude to give the percentage error shown in figure 1 below. These results clearly show how MALs are capable of performance similar to that of deformable mirrors.

Piezoelectric actuators however show hysteresis that can affect the device functionality during open-loop operation, as in the case of sensorless correction. For this reason it has been developed a model that, after a complete characterization of the lens in terms of hysteresis and dynamic behavior, allows a reliable open loop control<sup>4</sup>.

### 3. IMPLEMENTATION ON MICROSCOPES

In order to compensate for optical aberrations in microscopy systems, the deformable lens is simply screwed on the microscope objective holder of the microscope, and the objective is screwed on the opposite side of the lens.

Due to this modification, the position of the objective is shifted axially of a distance equal to the thickness of the mechanical enclosure of the adaptive lens, which is approximately 1cm. In most microscopes, focus control is achieved by shifting the objective axially, and the range of adjustment easily exceeds 1 cm, so this modification does not affect noticeably the performances of the microscope. The only hardware modification that may be necessary is a relocation of the sample holder, which, in the inverted setup used in the experimental results section, was easily achieved through the use of spacers on the sample holder mount.

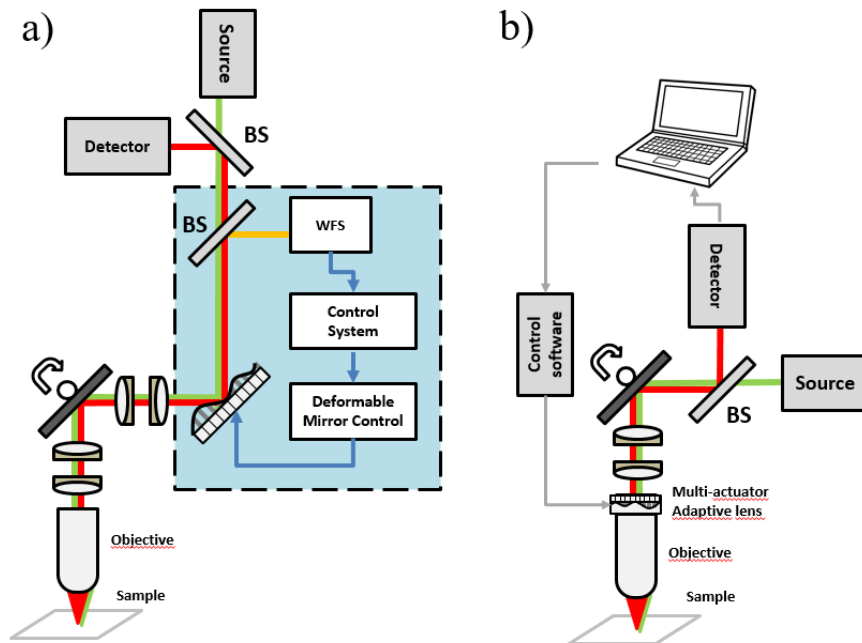

Figure 2. Scheme of adaptive optics implementation in a scanning microscopy system for **a)** a mirror based, wavefront sensing setup, and **b)** a lens based, sensorless setup. The blue square in panel **a)** shows the components that should be added to an existing setup to implement adaptive optics. It is apparent how such modification is structural, and of difficult implementation in an existing system.

Since the back aperture plane of the objective is normally located within the objective, the adaptive optical element is not located exactly in the pupil plane of the system. This requires the diameter of the adaptive lens to be slightly wider than the aperture of the objective lens, to avoid vignetting artifacts in the image.

The 1cm diameter of the lens used in the experiments is appropriate for most high performance microscopy objectives, which have apertures in the order of 6-8 mm, but a different adaptive lens may be needed for low-magnification, high aperture objectives, such as those used for high end in-vivo multiphoton imaging applications.

#### 4. CORRECTION ALGORITHMS

Due to the low brightness of microscopy signals, especially in fluorescence microscopy applications, and to the absence of natural bright stars in microscopy samples, the use of closed loop adaptive optics techniques in microscopy is difficult to implement. As a consequence, most reported implementations of adaptive optics in microscopy use wavefront sensorless correction techniques.

In the most common approach to sensorless aberration correction in imaging systems, an image metric is used to evaluate the performance of the correction applied, and an optimization algorithm is used to find the set of actuator voltages for the adaptive element which maximize (or minimize) the metric.

A variety of image metrics can be used to evaluate the performance of correction in microscopy, and the working principle of the microscope used should be carefully considered when selecting a metric.

In the case of both laser scanning confocal and laser scanning multiphoton microscopy, in the presence of an aberration, the total detected intensity decreases as the aberration increases, and can be therefore effectively used as a metric for sensorless aberration correction. This is due to the fact that the size of the point spread function depends on the amplitude of the aberration: in a confocal microscope a wider system point spread function will result in more light being

rejected by the pinhole, while in a multiphoton microscope it will result in a lower irradiance at the focal point, which will reduce the two photon absorption due to its intrinsic non linearity.

The results presented in the following section were acquired on a laser scanning confocal microscope, and the metric employed was the total intensity of the image. However, the method reported could be easily implemented, with a different metric, in microscopy systems where the total image intensity is not dependent on the aberration (e.g. epifluorescence microscopy, lightsheet microscopy, structured illumination microscopy). Possible metrics to be used in such case are image sharpness, or image Fourier content.

The correction algorithm implemented was the Data-based Online Nonlinear Extremum-seeker (DONE) algorithm<sup>5</sup>, previously successfully implemented in other imaging techniques in our group<sup>6,7</sup>. The DONE algorithm is an optimization algorithm based on the recursive creation of a nonlinear model of the metric function during the optimization procedure itself. Each time a new measurement is taken, the model of the metric function is updated with the new measurement, and the following measurement is performed in the maximum of the new model.

The main advantages in the use of the DONE algorithm are its robustness to measurement noise and small dynamic variations in the metric function, which could be introduced by a temporal variation in the sample itself (e.g. photobleaching, sample movement, focus drift) or by poor compensation of the actuator's hysteresis and dynamics.

## 5. RESULTS

Measurements were performed on a commercial laser scanning confocal microscope (SP5, Leica, Germany). Since the software controlling the microscope provides no options to transfer the images in real time to external software, we employed an internally developed software which grabs the screen output of the computer. We chose to apply our method to this microscope, as this represents the "worst case scenario" for implementation of adaptive optics in an existing optical system. The hardware of the microscope is extremely compact, precluding the possibility of adding a telescope system conjugating the aperture of the system to a deformable mirror, and the software is completely closed source, and does not allow access to the acquired images or the microscope settings to external scripts or software.

Synchronization with the microscope timing was provided through a low cost digital I/O board (USB6501, National Instruments, USA), using the digital trigger ports of the microscope itself. Timings were set up so that, for each measurement, new voltages were applied to the lens actuators, and the acquisition of an image was triggered after waiting for a 50ms settling time for the actuators, and the screen image was grabbed 16 ms (the screen refresh time) after the end of the image acquisition.

Images were acquired at 2 frame per second, with a 10X, 0.4 N.A. dry microscopy objective. The metric used was the total fluorescence intensity of the images. Optimization was performed over 7 degrees of freedom, namely Zernike coefficients 5 to 11 according to Noll's notation, consisting on all coefficients up to Spherical aberration, excluding Piston, Tip, Tilt and Defocus. Optimization was run for 200 seconds.

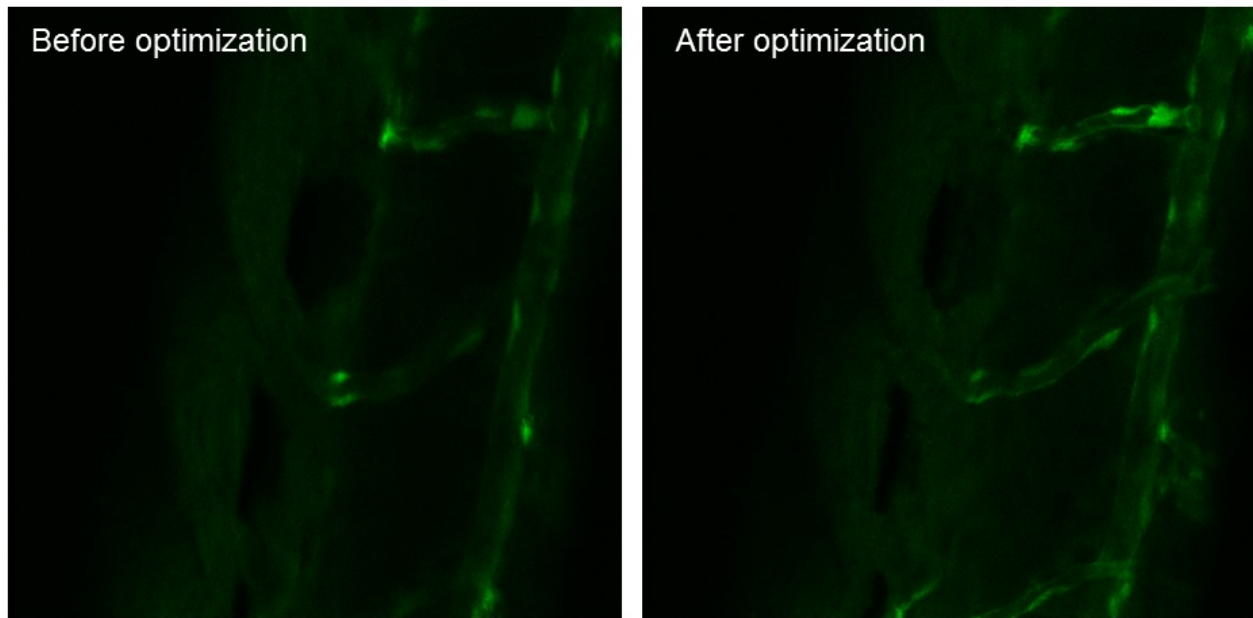

Figure 3. Representative results of the sensorless correction procedure. It can be observed how the blood vessels appear sharper and brighter after optimization.

Correction was performed on FLI:GFP Zebrafish larvae, paraformaldehyde fixed 5 days post fertilization. The larvae were embedded in agarose, and mounted on a square glass capillary, with inner size of  $800 \times 800 \mu\text{m}^2$ . Usage of a dry objective for imaging within agarose embedded, three dimensionally structured samples introduces significant phase aberrations. Use of the MAL for correction greatly improved the quality of images, as reported in the example in Figure 3.

## REFERENCES

- [1] Booth, M.J., "Adaptive optical microscopy: the ongoing quest for a perfect image," *Light: Science & Applications* 3(4), e165 (2014).
- [2] Ji, N., "Adaptive optical fluorescence microscopy," *Nature methods* 14(4), 374–380 (2017).
- [3] Bonora, S., Jian, Y., Zhang, P., Zam, A., Pugh, E.N., Zawadzki, R.J., and Sarunic, M. V., "Wavefront correction and high-resolution in vivo OCT imaging with an objective integrated multi-actuator adaptive lens," *Optics Express* 23(17), 21931 (2015).
- [4] Bijlsma, H., Pozzi, P., and Verhaegen, M., "Feedforward Compensation of Hysteresis and Creep in Adaptive Optics Devices," *Technische Universiteit Delft* (2016).
- [5] Verstraete, H.R.G.W., Wahls, S., Kalkman, J., and Verhaegen, M., "Model-based sensor-less wavefront aberration correction in optical coherence tomography," *Optics letters* 40(24), 5722–5 (2015).
- [6] Pozzi, P., Wilding, D., Soloviev, O., Verstraete, H., Blik, L., Vdovin, G., and Verhaegen, M., "High speed wavefront sensorless aberration correction in digital micromirror based confocal microscopy," *Optics Express* 25(2), 949 (2017).
- [7] Verstraete, H.R.G.W., Heisler, M., Ju, M.J., Wahl, D., Blik, L., Kalkman, J., Bonora, S., Jian, Y., Verhaegen, M., et al., "Wavefront sensorless adaptive optics OCT with the DONE algorithm for in vivo human retinal imaging [Invited]," *Biomedical Optics Express* 8(4), 2261 (2017).