

Design of a belt conveyor for the TEL laboratory

Research assignment ME54015



Author:

Jan van Kampen – 1359177

Specialization: Transport Engineering and Logistics

Report number: 2018.TEL.8241

Title: Design of a belt conveyor for the TEL
laboratory

Author: Jan van Kampen

Title (in Dutch): Het ontwerp van een lopende band voor het TEL laboratorium

Assignment: Research assignment

Confidential: No

Supervisor: Dr. Ir. Y. Pang

Date: June 1, 2018

This report consists of 19 pages and an Appendix. It may only be reproduced literally and as a whole. For commercial purposes only with written authorization of Delft University of Technology. Requests for consult are only taken into consideration under the condition that the applicant denies all legal rights on liabilities concerning the contents of the advice.

Abstract

The TEL laboratory is in need of a new belt conveyor that can replace their current belt conveyor. This report explores possible options and comes with a design of a conveyor that satisfies the design criteria given by the staff of the TEL laboratory.

The current conveyor is not suited for the continuous transport of bulk material, it is also deemed too heavy and cumbersome. The design of the new belt conveyor is capable of continuous transport of bulk material and is also slimmer and lighter than the current conveyor.

The final design is a conveyor with a belt width of 400 mm, capable of speeds between 1 and 5 m/s. The conveyor is designed to transport sand with a bulk density of 1600 kg/m^3 . The weight of the conveyor is just under 400 kg. However the weight of the motor and gearbox is not taken into account. If the conveyor is fitted with a 4 kW motor the weight of the conveyor is approximately 460 kg and if the conveyor is fitted with a 5,5 kW motor, the weight of the conveyor is approximately 485 kg. Drawings and information on the purchased parts can be found in Appendix Drawings & Information sheets.

Several safety measures are listed in order to ensure that the conveyor can be operated safely. Suggested are a fence with a safety lock, an emergency stop on the inside and outside of the fence and a pull cord running along the conveyor.

Content

- 1 Introduction..... 1
- 2 Initial approach..... 2
 - 2.1 Obtaining data..... 2
 - 2.2 The initial design..... 4
- 3 A second attempt 5
 - 3.1 Taking a new approach..... 5
 - 3.2 A new design 6
- 4 The final design..... 10
- 5 Safety measures. 13
- 6 Purchased parts 15
 - 6.1 Electric motor and gearbox 15
 - 6.2 Conveyor belt 16
 - 6.3 Rollers 16
 - 6.4 Bearing and bearing house..... 16
- 7 Conclusion 17
- 8 Recommendations for future research 18
- Sources 19

1 Introduction

The TEL laboratory is currently in possession of a conveyor for testing purposes that is not meeting the needs of the staff. When the department staff was interviewed, they listed several issues with the current conveyor. They are:

- The conveyor is too large
- The conveyor is too heavy
- The conveyor is hard to move from its place
- The conveyor is not suited for the continuous transport of materials

This meant that a new conveyor should be lighter, slimmer, and easier to move. Also the design of the conveyor should enable it to convey material in a continuous loop using a configuration with four conveyors. Furthermore the new conveyor will be placed on the spot of the old conveyor, and should fit in roughly the same area. Because of the variety of tests, it was deemed convenient if the troughing angle could be adapted. A last request was made that the conveyor should run at speeds between 1 and 5 m/s. This all lead to the following design demands:

- The new conveyor must be lighter than the old conveyor
- The new conveyor must be slimmer than the old conveyor
- The new conveyor should be easier to move than the old conveyor
- The new conveyor has to be able to transport material in a continuous loop
- The new conveyor has to fit in the space of the current conveyor
- The troughing angle of the new conveyor must be adaptable
- The conveyor needs to run at speeds between 1 and 5 m/s

In order to understand conveyors better, some literature was consulted. This consisted of slides from the course WB3420 Introduction Transport Engineering and Logistics on the topic of belt conveyors. Furthermore (Jagtap, et al., 2015) was used to gain insight in the design approach of a belt conveyor. The conveyor itself was designed based on the calculations of Rulmeca from their design guide (Rulmeca, 2017). Further information was obtained from (Leijendeckers, et al., 2002), (Bobak, 2017) and (DIN 22101, 2002). To come up with a design and drawings, Inventor 2018 was used.

This report consists of eight chapters. There are three iterations of the belt conveyor, discussed in three chapters. The design process is described over the course of Chapters 2, 3, 4 as well as the calculations and designs that were made. The safety measures to ensure safe operation of the conveyor is discussed in Chapter 5. Next the parts that have to be purchased are discussed in Chapter 6, before a conclusion and recommendations for further research are given in Chapters 7 and 8. Along with the report, a separate file, Drawings & Information sheets, consisting of all drawings and information sheets exists and can be read for additional information.

2 Initial approach

Based on (Jagtap, et al., 2015) the first thing that needs to be taken into consideration when designing a bulk conveyor is the amount of material that needs to be transported over a certain time period. This leads to a certain capacity and based on this number, further calculations and assumptions can be made in order to come up with a design for a conveyor. However, capacity was not specified in the demands, since the primary point of the new conveyor would be to run tests. Capacity was not considered a vital demand.

This led to a new approach where the surface area, on which the conveyor would be placed, was critical in assessing the possibilities of a potential conveyor. The current conveyor is approximately 3 meters long and 1,25 meters wide. This meant that the maximum width of the belt would be around 800 mm. This figure, together with the initial maximum speed of 5 m/s was used to come up with a capacity that could be used to create an initial design.

2.1 Obtaining data

The cross-sectional area is shown in Figure 1. The dimensions in the figure are in millimeters and are based on the 800 mm wide belt. The bottom dimension is 1/3 of 800 mm. The two angled lines are similar and the length is based on (Rulmeca, 2017), which states that the distance between the edge of the belt and transported material should be equal to $0,05 \cdot 800 + 25 = 65$ mm. This led to the length of 201,667 mm. The arc is the tangent to the angle of surcharge. Using Inventor, the cross-sectional area was computed. The cross-sectional area was found to be $0,11 \text{ m}^2$. Combining this number with the desired speed gave an initial volume flow of $0,51 \text{ m}^3/\text{s}$. The next step was to find a suitable bulk material to come up with a capacity. Based on the list provided by (ANVAL VALVES PVT LTD, 2017) iron ore, with a bulk density of $2,6 \text{ ton}/\text{m}^3$, was chosen. Iron ore was chosen for its high bulk density and the fact that it is a common material often transported on belt conveyors.

Combining the volume flow with the bulk density of iron ore gives a capacity of 1,33 ton/s or 4774 ton/hour. With this capacity the design guide by (Rulmeca, 2017) was followed in order to come up with an initial design.

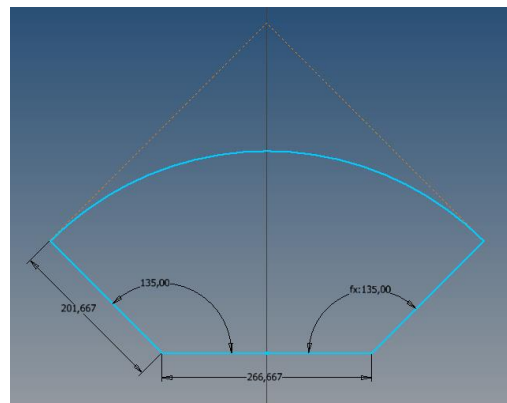

FIGURE 1: CROSS-SECTIONAL AREA OF 800 MM WIDE BELT

The tangential force at the pulley was found with Equation 1

$$F_u = [L \times C_q \times C_t \times f (2 q_b + q_G + q_{RU} + q_{RO}) \pm (q_G \times H)] \times 9,81 \quad (1)$$

In which:

- F_u [N]: Tangential force at the pulley
- $L = 3.16$ [m]: Distance between the pulleys
- $C_q = 9$ [-]: Fixed coefficient of resistance
- $C_t = 1$ [-]: Passive coefficient of resistance
- $f = 0.02$ [-]: Coefficient of friction internal rotating parts
- $q_b = 12$ [kg/m]: Belt weight per linear meter
- $q_g = 286$ [kg/m]: Weight of conveyed material per linear meter
- $q_{ru} = 8,6$ [kg/m]: Weight of the lower rotating parts
- $q_{ro} = 11,4$ [kg/m]: Weight of the upper rotating parts
- $H = 1$ [m]: Height change of the belt

All values in the equation can either be found in the (Rulmeca, 2017) design guide or follow from design choices. The only exception to this is the value of C_q which was found by extrapolating the values found in (Rulmeca, 2017). The resulting tangential force was found to be 4328 N. When we multiply that number with the desired speed, the required power is obtained, 21,6 kW.

Next, the minimum belt tension with respect to sag was found using Equation 2

$$T_1 = 6.25 * (q_b + q_g) * a_0 * 9,81 \quad (2)$$

In Equation 2 a_0 is the pitch between the idlers and the number 6.25 corresponds to a belt sag of less than 2% of the distance between the idlers. 2% belt sag or less is important to reduce spillage and improve the efficiency of the belt conveyor. With these numbers a belt tension of 15466 N was found. The belt tension behind the drive pulley was found using Equation 3

$$T_2 = T_1 - F_u \quad (3)$$

The tension behind the pulley $T_2 = 11138$ N, along with T_1 is used to determine if the tension is large enough to move the belt with just the friction on the pulley. This is done by evaluating Equation 4

$$\frac{T_1}{T_2} \leq e^{\mu\alpha} \quad (4)$$

With:

- $\mu = 0,4$ [-] Coefficient of friction between steel and rubber (DIN 22101, 2002)
- $\alpha = 150^\circ = 0,83\pi$ rad Wrap angle of the conveyor belt

The left side of Equation 4 is equal to 1,39 and the right side of Equation 4 is equal to 3,28. This means that Equation 4 holds and that the belt tension is high enough to ensure motion.

Using Equation 5 the maximum belt tension is determined.

$$T_{umax} = \frac{T_{max} * 10}{N} \quad (5)$$

In this equation, $T_{\max} = T_1$ and N is the belt width in millimeters. Using the values obtained with the help of the previous equations T_{\max} is found to be equal to 193 N/mm. Using (Rulmecca, 2017), the size of the drive pulley and return pulley can be determined. The drive pulley has a diameter of 200 mm and the return pulley has a diameter of 160 mm. A rudimentary design was made and can be seen in Figure 2.

2.2 The initial design

This design features a 800 mm wide belt and a fixed trough angle of 20°. There are several issues with this design that are not addressed in this sketch. They are, among others:

- No bearings to hold the drive and return axle in their place
- No way of countering forces along the axles due to loading
- Large angles of inclination due to the height of the idler sets

The reason why these issues were not addressed is because the width of the belt has large implications on the overall feasibility of the conveyor and the demands that were placed on it. Due to the width of the belt, the conveyors would have to be placed in a way they can narrowly miss each other. This would make transfer between the different conveyors difficult and would likely lead to spillage. Furthermore the goal of the new conveyor was never to move as much material as possible. There were demands to have a lighter, and more mobile conveyor than the one that is currently used. According to Inventor, the weight of this conveyor is approximately 600 kg. It seems plausible that the weight will decrease if a smaller conveyor will be designed.

These were the reasons to stop the development of the first iteration of the new conveyor. The choice was made to start over and to look at the design process where improvements could be made. It was assessed that capacity was not the main concern and a new starting point for the design of the conveyor had to be found. A sketch of this conveyor can be found in Appendix C.

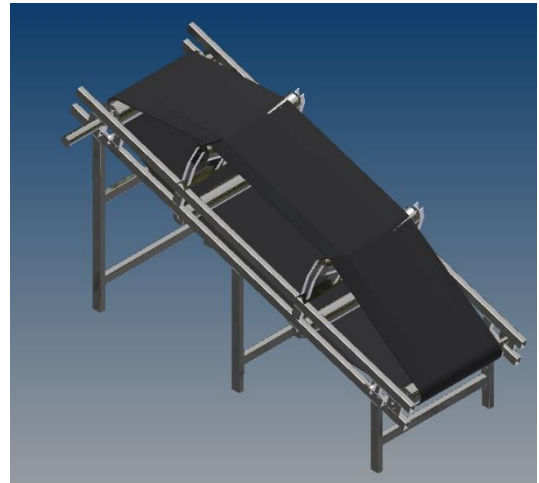

FIGURE 2: DESIGN OF THE CONVEYOR BELT WITH A BELT WIDTH OF 800 MM

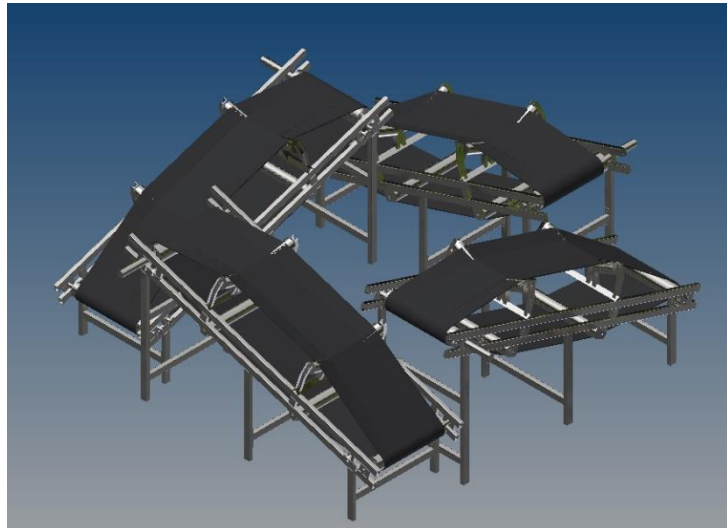

FIGURE 3: PROPOSED SETUP OF FOUR CONVEYORS IN A SQUARE

3 A second attempt

In order to come up with a new starting point for the design of a conveyor, the demands, along with the design guide (Rulmeca, 2017), and the initial approach were reassessed. The main lesson that was taken away from the first attempt was that the steps in the design guide, starting at the capacity of the conveyor could lead to a functioning conveyor.

3.1 Taking a new approach

One of the few clear demands was that the current conveyor is too big and cumbersome to use and move. Therefore the next attempt to design a conveyor focused on making a slimmer design for a conveyor. Looking at a list of standardized belt widths in (Rulmeca, 2017), the lowest belt width to appear is 400 mm. This number was used to come up with a new capacity based on the cross-sectional area and the desired belt speed.

Using Inventor to find the cross-sectional area and the desired belt speed a new capacity for a smaller conveyor belt can be obtained. With this capacity the same design guide can be followed again to come up with a new design.

Looking at a belt with a width of 400 mm, a cross-sectional area of 0,02 m² was found, shown in Figure 3. The dimensions are constructed in a similar way as in the previous cross-section calculation. The desired belt speed remains 5 m/s, which leads to a volume flow of 0,1 m³/s or 360 m³/h. In order to reduce the power that is needed to drive a new belt conveyor a lighter test material is suggested. When sand is used, the bulk density will lower to 1,6 ton/m³ instead of 2,6 ton/m³ when iron ore is used (ANVAL VALVES PVT LTD, 2017). This all leads to a capacity of 576 ton/h or 0,16 ton/s.

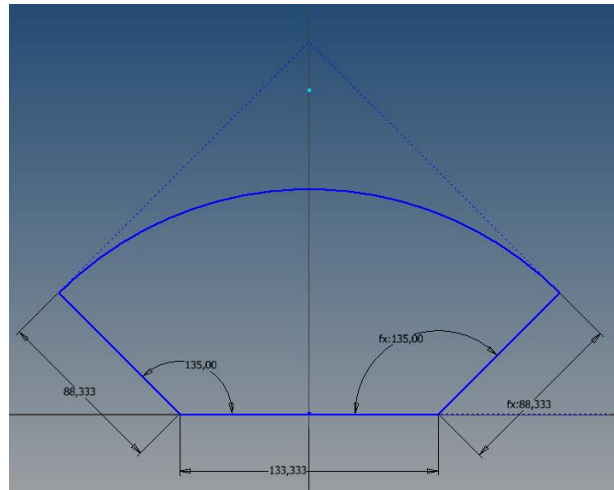

FIGURE 4: CROSS-SECTIONAL AREA OF 400 MM WIDE BELT

Following the same steps as the first iteration, first the tangential force at the drive pulley is calculated using Equation 1. With the following values:

- | | |
|---------------------------|---|
| - F_u [N]: | Tangential force at the pulley |
| - $L = 3.16$ [m]: | Distance between the pulleys |
| - $C_q = 9$ [-]: | Fixed coefficient of resistance |
| - $C_t = 1$ [-]: | Passive coefficient of resistance |
| - $f = 0.02$ [-]: | Coefficient of friction internal rotating parts |
| - $q_b = 8$ [kg/m]: | Belt weight per linear meter |
| - $q_g = 23,5$ [kg/m]: | Weight of conveyed material per linear meter |
| - $q_{ru} = 8.6$ [kg/m]: | Weight of the lower rotating parts |
| - $q_{ro} = 11,4$ [kg/m]: | Weight of the upper rotating parts |
| - $H = 1$ [m]: | Height change of the belt |

This results in a tangential force of 623 N. Combining this with the desired speed of 5 m/s this comes down to a power consumption of 3,2 kW. The next step is to find the tension needed to keep the belt sag at an acceptable level of 2%. Using Equation 2 T_1 is found and is equal to 1849 N. This leads to a T_2 of 1226 N. As Equation 4 holds, with $\alpha = 0,94\pi$ rad and $\mu = 0,4$, the tension is sufficient to ensure motion. Using Equation 5 $T_{umax} = 46$ N/mm. Based

on these calculations a drive pulley with a diameter of 200 mm and a return pulley of 160 mm is chosen. (Rulmeca, 2017)

3.2 A new design

Using these calculations a second design was made. This design can be seen in Figure 5. When compared to the first design, the first thing that stands out is that the second design is slimmer than the first design. Also the idler sets are adjustable, the troughing angle can be changed from 0° to 45°. The idler set is shown in Figure 6.

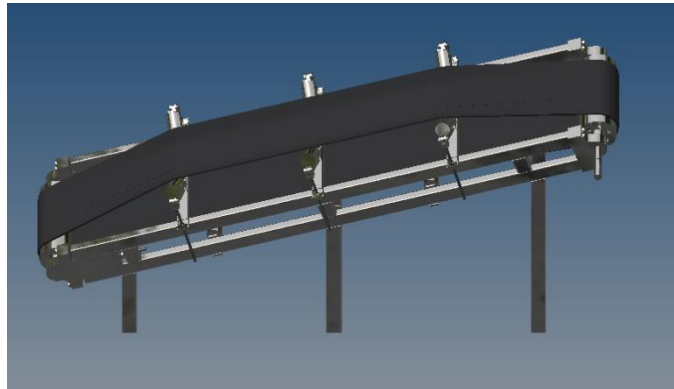

FIGURE 5: THE SECOND DESIGN

Based on the design shown in Figure 5, (Rulmeca, 2017) could be explored further. The next step is to dimension the drive axle. This is done based on the forces that act on the axle, the bending moment and torsional moment on the axle and weight of the pulley itself.

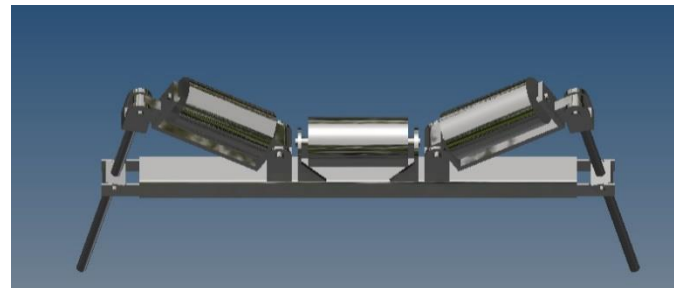

FIGURE 6: THE ADJUSTABLE IDLER SET

The resultant of the tensions C_p can be found by using Equation 6.

$$C_p = \sqrt{(T_1 + T_2)^2 + q_t^2} \quad (6)$$

In this equation, T_1 and T_2 are the belt tension before and after the drive pulley, $q_t = 200$ N is the weight of the pulley. Using these numbers, $C_p = 3066$ N. This number can be used in Equation 7 to find the bending moment M_f .

$$M_f = \frac{C_p}{2} * a_g \quad (7)$$

With:

- $a_g = 84,4$ [mm] The distance between the bearing and the pulley
- $C_p = 3066$ [N] Resultant tension

This results in a bending moment $M_f = 129,4$ Nm. The next step is to find the torsional moment M_t this is done with Equation 8.

$$M_t = \frac{P}{n} * 9.549 \quad (8)$$

With:

- $P = 3194$ [W] Absorbed power
- $n = 477$ [rpm] revolutions per minute
- $9,549$ Correction factor to compensate units

Using this equation, $M_t = 63,9 \text{ Nm}$ is found, using the values M_f and M_t we can find the ideal bending moment M_{if} with Equation 9.

$$M_{if} = \sqrt{M_f^2 + 0,75M_t^2} \quad (9)$$

The ideal bending moment $M_{if} = 140,7 \text{ Nm}$ is used to find the module of resistance with Equation 10.

$$W = M_{if} * \frac{1000}{\sigma} \quad (10)$$

With:

- $\sigma = 78,2 \text{ [N/mm}^2\text{]}$ Admissible stress (Rulmecca, 2017)
- 1000 [-] Correction factor to compensate units

Using the module of resistance, the diameter of the shaft can be calculated using Equation 11.

$$d = \sqrt[3]{\frac{W * 32}{\pi}} \quad (11)$$

Using the value of $W = 1799 \text{ mm}^3$ a shaft diameter of $26,4 \text{ mm}$ is found. This value was lower than expected and therefore another Equation 12 by (Leijendeckers, et al., 2002) was used to check the diameter of the axle.

$$d \approx 0,129 \sqrt[4]{\frac{P}{n}} \quad (12)$$

With:

- $P = 3,2 \text{ [kW]}$ Transferred power
- $n = 477,5 \text{ [rpm]}$ Revolutions per minute

Using Equation 12 a diameter $d = 36,9 \text{ mm}$ is found. To be sure that the axle is thick enough, the larger diameter was chosen. Rounding up to a more convenient size gives us a shaft with a diameter of 40 mm . For convenience, the return shaft is given the same size.

Finally, the shaft needs to be checked for deflection and angle of deflection. This is done using Equations 13 & 14.

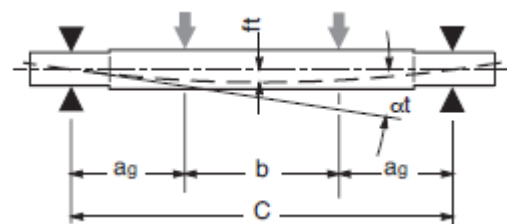

FIGURE 7: OVERVIEW OF DIMENSIONS USED IN EQUATIONS 13 & 14 (RULMECCA, 2017)

$$ft = \frac{\left(\frac{C_p}{2}\right) a_g}{24 * E * J} \left(3(b + 2a_g)^2 - 4a_g^2\right) \leq \frac{C}{3000} \quad (13)$$

$$\alpha t = \frac{\left(\frac{C_p}{2}\right) a_g}{2 * E * J} \left(a_g(C - a_g)\right) \leq \frac{1}{1000} \quad (14)$$

With :

- $C_p = 3066$ [N] Load on the axle
- $a_g = 84,4$ [mm] Distance between the flange and the center of the bearing
- $b = 466.9$ [mm] Distance between the loads from the pulley on the axle
- $E = 206000$ [N/mm²] Module of elasticity of steel
- $J = 125696$ [mm⁴] Sectional moment of inertia
- $C = 635,7$ [mm] Distance between the centers of the bearings

Using a diameter of 40 mm, a value $ft = 2,96$ mm is found. This is larger than the $C/3000 = 0,21$ mm. This means that the diameter in the middle of the axle needs to be increased. After trial and error, a middle diameter of 80 mm, and $J = 2011136$ mm⁴, was found which suffices Equation 13. Next, the diameter of 80 mm is used to check if Equation 14 holds as well. When the values listed above are put in Equation 14 $\alpha t = 8,6 * 10^{-5}$ is found. This value is under 0.001, therefore Equation 14 holds for a diameter of 80 mm. Since both equations hold, the diameter of the shaft is sufficient and a more detailed design can be made.



FIGURE 8: DESIGN OF A CONVEYOR WITH A BELT WIDTH OF 400 MM

The first thing that stands out in the second design, shown in Figure 8, is the fact that the second conveyor is slimmer than the first conveyor. The decreased belt width, 400 mm instead of 800 mm wide, results in a conveyor that is 700 mm wide instead of 1160 mm wide. The weight of this version of the conveyor is around 400 kg. This is a 200 kg improvement over the previous conveyor.

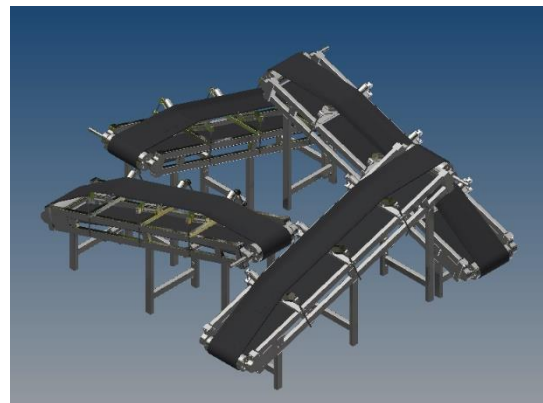

FIGURE 9: PROPOSED SETUP OF FOUR CONVEYORS IN A SQUARE

The decreased width of the conveyor also makes it more flexible in placing it in a loop. The slimmer design ensures that there is more room to move the conveyor with respect to each other without the belts intersecting. A picture of a proposed set up can be seen in Figure 9.

The troughing angle can be adjusted due to the new idler sets that have been designed, shown in Figure 10 & Figure 11. These idler sets can be adjusted using the threads on the side of them. The troughing angle can be set at any angle between 0° and 45°. The middle roll in the idler set is kept level with respect to the base of the idler set. The two rollers on the side

are held in place with hinges on both sides, ensuring that the rolls can tilt with respect to the middle roll.

However, this idler set has the downside that a 74 mm gap exists between the middle roll and the outer to rolls. This is due to the hinge that is located between the outer roll and the inner roll, shown in Figure 11. This gap was deemed too big and so a new idler set design was created.

Another new addition are the bearing houses that are used to keep the drive and return axle in their place. Both sets of bearing houses are located at the end of the frame with the bearings at the return end being placed on a mount so that the belt tension can be adjusted. The position of the bearing house can be adjusted by tightening a nut on the thread shown in Figure 12. When the nut is tightened, the belt tension increases, when it is loosened, the belt tension loosens as well.

One of the things that is not taken into account is the stiffness of the frame. Since there is no diagonal brace between the left and right side of the frame, shearing between these two parts cannot be prevented.

The second conveyor, with its slimmer and lighter design, seemed to comply better with the demands that were made. Therefore a more detailed final design was made based on the second design. In this design, the idler set needs to be improved, the frame needs to be stiffened and details like bearings and fasteners need to be added. Sketches of the second design can be found in Appendix C.



FIGURE 10: ADJUSTABLE IDLER SET AT ANGLE OF 30°

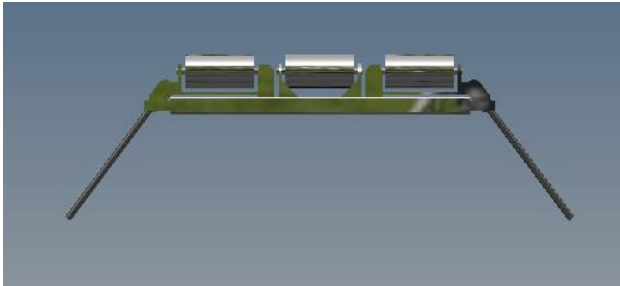

FIGURE 11: ADJUSTABLE IDLER SET AT AN ANGLE OF 0°, WITH A GAP OF 74 MM

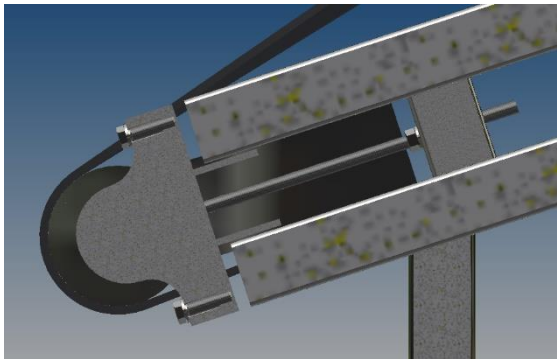

FIGURE 12: SECTION VIEW OF THE PROPOSED TENSIONER

4 The final design

Since the width of the conveyor belt stays the same as in the previous design, the cross sectional area is the same as well. This fact ensures that most calculations, made for the previous design still hold. The force, tension and required power are all the same as in the second design. A model of the final design can be seen in Figure 13.

There are some differences between the second and third design. The adjustment that stands out the most is the different idler set. Instead of an idler set that can be adjusted with the help of hinges, an idler set with Garland rollers is selected to reduce the gaps between the rollers. The idler set can be seen in Figure 15 and Figure 14. The adjustment mechanism has also changed. The threads on the side of the idlers have been replaced with fixed wing shaped mounts with holes located at regular intervals. This change limits the choice of troughing angles, with the previous design any angle could be chosen. With the new design, only troughing angles of $0^{\circ} - 45^{\circ}$ at 5° intervals can be chosen. This is due to the removal of the middle hinges to reduce the gap between the roller. Whereas the previous idler set had a maximum gap of 74 mm, this design has a gap of 54 mm. The actual size of this gap can vary somewhat, depending on the specifications of the Garland rollers. The new idler sets have the added advantage over the previous set that apart from the motor and gearbox, nothing sticks out due to the removal of the threads.

Another change is the addition of diagonal braces to reduce shearing between the two sides of the conveyor frame. The diagonal braces can be seen in Figure 16.

Furthermore, the longest struts, located near the drive axle, are moved further back to ensure that the conveyors can be placed hanging over the next conveyor. This adaptation gives more freedom to place the conveyors according to the demands of the operator.

The belt can be tensioned with the help of a tensioner shown in Figure 17. The thread can be shortened when the rollers, idlers or the belt itself is in need of replacement. This is done by



FIGURE 13: THE FINAL DESIGN OF THE CONVEYOR BELT

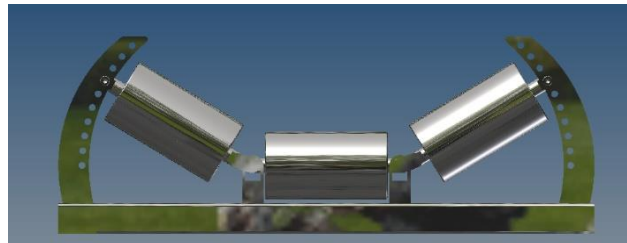

FIGURE 15: SIDE VIEW OF THE IDLER SET IN THE FINAL DESIGN

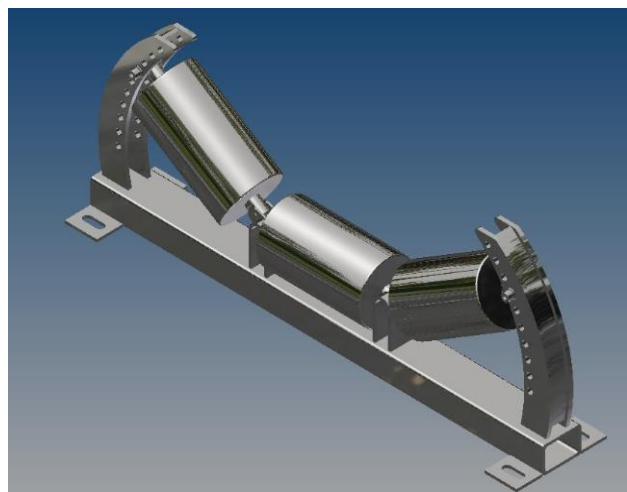

FIGURE 14: ISOMETRIC VIEW OF THE IDLER SET

loosening the nut shown in Figure 17. By doing so the axle is brought in thus lowering the tension on the belt. When the tension needs to be increased, to ensure motion or reduce sag, the nut can be fastened which increases the tension.

The pulley is fixated on the axle using a press fit. The torque on the pulley is calculated using Equation 15 by (DIN 22101, 2002):

$$T_p = \frac{F_u D_p}{2} \quad (15)$$

With:

- $F_u = 638,8$ [N] Tangential force at the pulley
- $D_p = 0,2$ [m] Diameter of the drive pulley

This leads to a value of $T_p = 63,9$ Nm. The drive and return pulley are secured on their axles using a press fit. The maximum transferable torque is calculated using Equation 16 by (Leijendeckers, et al., 2002).

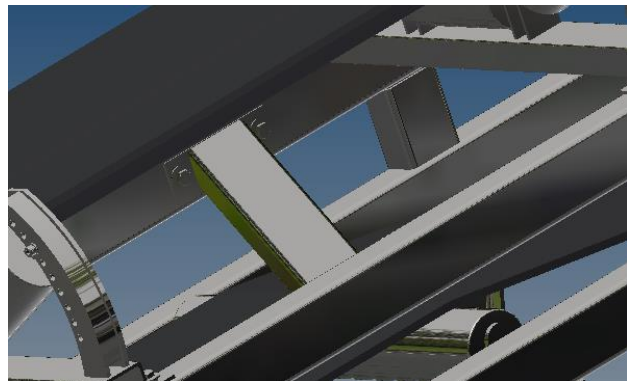

FIGURE 16: THE ANGLED STRUTS BETWEEN THE TWO HALVES OF THE FRAME

$$M = 0,5 * \pi d_a^2 * l * f * \bar{\sigma}_0 \quad (16)$$

With:

- $d_a = 80$ [mm] Diameter of the axle
- $l = 10$ [mm] Length of the press fit
- $f = 0.01$ [-] Friction coefficient
- $\bar{\sigma}_0 = 50 - 90$ [N/mm²] Admissible surface pressure

This gives us a maximum transferrable torque of 160.000 Nmm, or 160 Nm. The pulley is fastened on two places to the axle, which leads to maximum transferrable torque of 320 Nm. Since the transferrable torque is lower than the maximum transferrable torque, a press fit can be used to fix the pulley to the axle.



FIGURE 17: BELT TENSIONER AND BEARING

The weight of the conveyor is, according to Inventor, just under 400 kg. The weight of the motor and gearbox is not taken into account in this calculation.

Drawings of the conveyor can be found in Appendix A.

As with the previous iterations of the conveyor, the latest conveyor has to be placed in a continuous loop. The proposed setup is shown in Figure 18.

Like the previous conveyors, the setup consists of four conveyors placed in a square. Due to the distribution of the struts below the conveyor, the edge of the conveyor can be moved 90 mm further than the middle of the next conveyor, shown in Figure 19. Since the conveyor can always be moved backwards, the bulk material can be transferred at every speed between 1 and 5 m/s.

To ensure the transfer of material goes smoothly, a hopper can be designed. However, the design of such a hopper is outside the scope of this research.

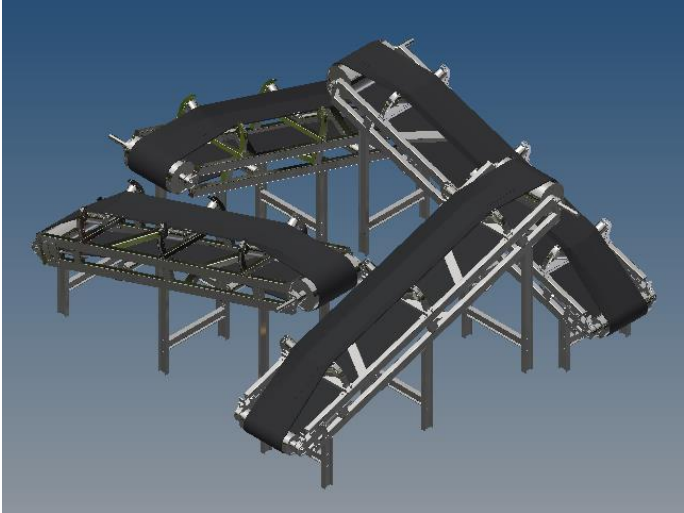

FIGURE 18: PROPOSED SETUP FOR THE CONVEYORS

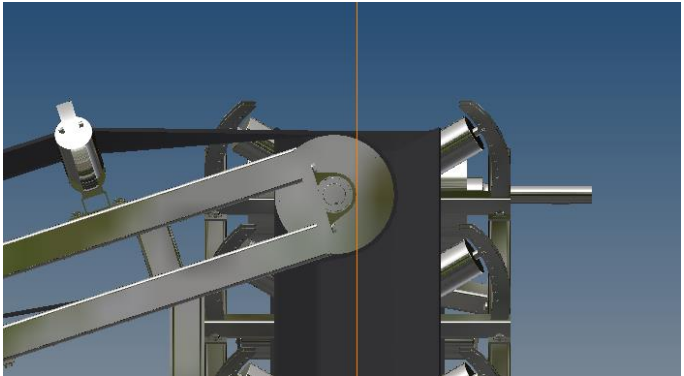

FIGURE 19: PLACEMENT OPTION FOR TWO CONVEYORS, THE ORANGE LINE INDICATES THE MIDDLE OF CONVEYOR THAT RECEIVES THE MATERIAL

5 Safety measures.

In order to make sure that the conveyor can be operated safely some safety measures are suggested. They are:

- Safety fence
- Emergency stop
- Pull cord

The main safety measure is a fence that should prevent people from reaching the conveyor while it is operational. The conveyor has several parts that can be dangerous for an operator or bystander. For example, someone can get caught between the belt and the rollers. The first thing that must be prevented is that people reach the conveyor when it is operational. This can be done with a fence that prevents the conveyor from working if the fence is opened and also locks automatically when the conveyor is turned on. This measure prevents people from entering and exiting the conveyor area when the conveyor is operational.

However, if people do get caught in the conveyor area, other options to ensure safety must be provided. This means that whenever this happens, a way to stop the conveyor and disengage any locks should be provided inside the conveyor area as well as outside. There are several safety measures that can be used in order to stop the conveyor's operation. The emergency stop being one of them. This device disrupts the electronic circuit, cutting the power to the motor.

A variation on this measure is the pull cord. This is a device that consists of a cord attached to a sensor that detects a force along the cord. If the cord is pulled or moved substantially, this motion is detected in the sensor and the power is cut as well. This measure is often used to ensure that an operator does not approach a machine unnoticed. When an operator gets too close to the machine, the pull cord is moved and the machine is shut down. This could also provide a safety measure when someone is locked in with the conveyor and needs to shut the machine down.

To find out how long it takes for the conveyor to stop moving based on the current specifications Equations 17 & 18 by (DIN 22101, 2002) are used.

$$a = \frac{Cf \left(L(m'_r + (2m'_g + m'_i)\cos\delta) \right) g + Hm'_g g}{L(m'_r + (2m'_g + m'_i)\cos\delta)} \quad (17)$$

With:

- $L = 3.16$ [m]: Distance between the pulleys
- $C = 10$ [-]: Sum of the coefficient of resistance
- $f = 0.02$ [-]: Coefficient of friction internal rotating parts
- $m'_g = 8$ [kg/m]: Belt weight per linear meter
- $m'_i = 23.5$ [kg/m]: Weight of conveyed material per linear meter
- $m'_r = 8.6$ [kg/m]: Weight of the rotating parts
- $H = 1$ [m]: Height change of the belt
- $g = 9.81$ [m/s²]: Gravitational constant
- $\delta = 18$ [°]: Angle of inclination of the belt

This leads to a deceleration $a = 1.99 \text{ [m/s}^2\text{]}$. Using this value the stopping time can be calculated using Equation 16.

$$dt = \frac{dV}{a} \quad (18)$$

With:

- $dV = 5 \text{ [m/s]}$

From Equation 18 a stopping time $dt = 2.51 \text{ [s]}$ is obtained. In this time the conveyor belt travels a maximum of 12.56 [m] . Taking into account that the length of the conveyor belt is approximately 6 meters, the conveyor continues for two full loops before it comes to a standstill. If this is deemed too long, additional brakes need to be added.

A combination of safety measures has to be installed in a way that ensures a safe operation of the conveyor.

6 Purchased parts

For this conveyor some parts need to be purchased. In this section all the purchased parts are discussed. They are:

- The electric motor and gearbox
- The conveyor belt
- The rollers
- The bearings and bearing houses

The details of these parts are listed in Appendix B

6.1 Electric motor and gearbox

The electric motor needs to deliver at least 3,2 kW. Assuming an efficiency of 94% for the gearbox (Bobak, 2017), a 3,5 kW motor is needed. Looking at standardized motors that can supply this level of power, a 4 kW motor would be sufficient. The gearbox needs to transform the power and frequency of the motor to workable levels. The desired torque and frequency to run the conveyor, that has a pulley with a diameter of 200 mm, at 5 m/s is 63,9 Nm and 477 rpm. An example of such a motor is the KAF39DRN112M4/TF 4kW electric motor supplied by SEW. This motor delivers 73 Nm at 523 rpm. Furthermore it is possible to fit the motor with a frequency control unit to allow for different speeds and it is safeguarded with 3 thermal sensors to prevent overheating. This would be sufficient for our needs.

However, after consulting with SEW, it became clear that running the motor at low speeds had severe consequences for the maximum torque and the runtime of the engine. Due to the low frequency at which the motor should run at low speeds, cooling the engine becomes harder due to the reduced speed of the cooling fan. According to the consultant of SEW, the maximum torque, when the belts run at 1 m/s, would be around 77% of the listed torque and a runtime of under ten minutes. This would result in a maximum torque of 56 Nm delivered by the engine, which would not be sufficient for our purpose.

Therefore the design was checked again and a larger pulley, with a diameter of 273 mm was designed. This meant that the required frequency was lowered to 349,8 rpm, but the required torque rose to 87,2 Nm. This led to another electric motor, KAF39DRN112M4/TF, however this version delivers 117 Nm torque at a speed of 325 rpm. This motor is identical to the previous motor, except the gear ratio is different. Like the previous motor, it is fitted with thermal sensors and can be fitted with a frequency control unit. At low speeds, it should be able to deliver 90,1 Nm torque which would be sufficient to run the belt at 1 m/s. However, due to the output speed of 325 rpm, the maximum belt speed would be only 4,6 m/s instead of 5 m/s.

Since both motors do not fully satisfy our needs, another motor was chosen. The KAF49DRN132S4/TF 5,5 kW motor, which delivers 143 Nm at 365 rpm. When a pulley with a 273 mm diameter is chosen, a motor with 365 rpm output speed would be able to run the conveyor belt at 5,2 m/s. Since the output torque is 143 Nm, at a belt speed of 1 m/s this would be approximately 110 Nm, which would be sufficient to drive the belt. Like the previous motors, this motor can be fitted with a frequency control unit and thermal sensors to prevent overheating.

The weight of the 4kW motor is 61,6 kg and the weight of the 5,5 kW motor is 87,1 kg.

Increasing the diameter of the pulley has consequences for the shrink fit between the pulley and the axle. Since the required torque increases, the shrink fit needs to be reexamined. The required torque increases from 63,9 Nm to 87,2 Nm, however, since the maximum transferrable torque is 320 Nm, the shrink fit will still function properly.

6.2 Conveyor belt

The conveyor belt needs to withstand a T_{umax} of 46 N/mm while in working condition. However, the tension during the startup phase of the conveyor is higher due to added force of the acceleration of the mass and belt. This tension can be calculated using Equation 19.

$$T_1 = M \frac{dV}{dt} + F_u + T_2 \quad (19)$$

With:

- $M = L(m'_r + (2m'_g + m'_i)\cos(\delta)) = 145,9$ [kg]
- $F_u = 639$ [N]
- $T_2 = 1210$ [N]
- $dV = 5$ [m/s]

The tension T_1 depends on the desired startup time. If a belt with a break force of 200 N/mm is chosen, a 400 mm wide belt can have a maximum allowable tension of 80.000 N. Taking the values above and Equation 19 would yield a minimum startup time of 0,009 seconds. However, such a startup time would need an acceleration of 556 m/s^2 , with such high accelerations, the material would not remain stationary with respect to the belt. This means that the a belt with a break force 200 N/mm would suffice since the break force is never reached under normal operating conditions. An example of such a belt is SKANPLY EP 200/2 2+1 Y. Such a belt would meet all requirements, although similar belts would also suffice.

6.3 Rollers

The rollers that have been used in the final design are based on the TS89-20A-200K rollers from Sandvik Mining and Construction, this number indicates that they have a 89 mm diameter a 200 mm length. 20A stands for the type and the thickness, 20 mm, of the center shaft. These rollers are designed for light duty conveying. Although the rollers from Sandvik Mining and Construction were chosen for the CAD models that were available, another supplier of similar rollers was found; transroll. This supplier sells rollers similar to the rollers from Sandvik and also provides specific lengths, shafts and coatings if requested. This ensures that the garland rollers can be made based on the rollers provided by transroll. The shaft is lengthened to accommodate for the chain link that is used for the connection between two rollers. The details of these changes can be found in the Appendix B.

The return rollers are based on the TS89-20A-530K rollers from Sandvik Mining and Construction. The rollers are identical to the rollers mentioned in the previous section, with the exception that that the length of the rollers is 530 mm. The bearings and seals are included in the rollers that are selected. Like the belt, electric motor and gearbox, several suppliers have similar products in stock.

6.4 Bearing and bearing house

In order to constrain the drive axle and return axle four bearing houses have to be purchased. The bearings that have been chosen are SKF-SY40-TF. These bearings are self-aligning and well suited for heavily polluted environments. The dynamic and static load rating are 30.7 kN and 19 kN respectively, which is sufficient for our purpose. The bearings are sold by several suppliers and comparable products are also available.

7 Conclusion

The final design is a conveyor with a belt width of 400 mm, capable of speeds between 1 and 5 m/s. The conveyor is designed to transport sand with a bulk density of 1600 kg/m^3 . The weight of the conveyor is just under 400 kg. However the weight of the motor and gearbox is not taken into account. If the conveyor is fitted with a 4 kW motor the weight of the conveyor is approximately 460 kg and if the conveyor is fitted with a 5,5 kW motor, the weight of the conveyor is approximately 485 kg.

When looking at the design criteria, the conveyor complies with most criteria. The conveyor is slimmer than the previous conveyor, it is easier to move either with the addition of wheels or with the use of two pallet trucks. The conveyor can be placed in a configuration that transports material in a continuous loop. The conveyor is slimmer than the current conveyor so it fits in the space of the current conveyor. The troughing angle is adjustable between 0° and 45° at 5° intervals, and conveyor can run between 1 and 5 m/s.

It is not known whether the conveyor is lighter than the current conveyor, since the weight of the current conveyor is not known. However, the weight of the first design is approximately 600 kg without motor and gearbox and this design is roughly the same size as the current conveyor. Since the final design is 200 kg lighter than the first design, the final design is most likely lighter than the current conveyor.

The final design and the report give a suggestion for a conveyor that will fit the needs of the TEL laboratory better than the current conveyor. If there are additional demands in the future, the design may need to be updated.

Most components of the conveyor are designed, drawings of these components can be found in the Appendix A. The parts that have to be bought are the motor and gearbox, the belt, the rollers and the bearings and housing, details about these parts can be found in Appendix B.

Several safety measures are given in order to ensure that the conveyor can be operated safely. Suggested are a fence with a safety lock, an emergency stop on the inside and outside of the fence and a pull cord running along the conveyor.

8 Recommendations for future research

Further research to improve the conveyor or the transfer of bulk material can be done. New research can focus on the limits of the conveyor. The conveyor is designed to transport sand at a maximum speed of 5 m/s. Other bulk materials can be looked into, for example iron ore, which has a higher bulk density or for example rice, which has a lower bulk density. (ANVAL VALVES PVT LTD, 2017). Perhaps the conveyor is suited for these materials as well, which would add to the versatility of the conveyor, increasing the possibilities for testing different materials.

Although the conveyor complies with the demands of the staff, a closer look at some of the components can be done to see if matches requirements, not yet available at this time, better. The electric motor that was chosen, the 5,5 kW motor by SEW, is chosen because it was the only one of the three motors to comply with the desired speed and was strong enough to deliver the required torque. However, if the desired speed would be decreased to 4 m/s, the 4 kW, 117 Nm at 325 rpm, motor would suffice. This could reduce the purchase cost of the conveyor, which will be interesting if the budget is not sufficient or if the conveyor would ever be produced in larger volumes.

In order to ensure the transfer of material goes smoothly, a hopper can be designed to catch material transferring from one conveyor to the next. This hopper should fit the conveyors and would be made specifically for them.

Lastly, the possibility to place sensors on or around the conveyor can be examined, and if necessary the design may need to be altered.

Sources

ANVAL VALVES PVT LTD, 2017. *Bulk Density Chart*. [Online]

Available at: <http://www.anval.net/Downloads/Bulk%20Density%20Chart.pdf>

[Accessed 10 2017].

Bobak, T. . R., 2017. *How Green is Your Gearbox?*, Chesapeake, Virginia: Sumitomo Drive Technologies.

DIN 22101, 2002. *DIN 22101: Gurtförderer für Schüttgut—Grundlagen für die Berechnung und Auslegung (Belt conveyors for bulk materials – Fundamentals for calculation and design)*, Berlin: Deutsches Institut für Normung.

Jagtap, A. et al., 2015. DESIGN OF MATERIAL HANDLING EQUIPMENT: BELT CONVEYOR SYSTEM FOR CRUSHED BIOMASS WOOD USING V MERGE CONVEYING SYSTEM. Volume 2015.

Leijendeckers, P., Fortuin, J., Van Herwijnen, F. & Schwippert, G., 2002. *Polytechnisch Zakboek*. 49 ed. Arnhem: Elsevier.

Rulmeca, 2017. *Technical Information project and design criteria for belt conveyors*. Almè Bergamo: Rulmeca.