

Energy Reduction Façade Renovation System

for different building typologies and climates



Iason Vovos



Energy Reduction Façade Renovation System for different building typologies and climates.

MSc Thesis Delft University of Technology

© 2021 Iason Vovos

All rights reserved. No part of this publication may be reproduced in any form or by any means, electronically, mechanically, by print or otherwise without written permission of the copyright owner.

Title:

Energy Reduction Façade Renovation System for different building typologies and climates.

Author:

Iason Vovos
Student number 5149134

Report:

MSc. Graduation Thesis
Building Technology

Institution:

Delft University of Technology
Faculty of Architecture
30 June 2021

Mentors

1st Mentor: Dr. Ing Thaleia Konstantinou | Façade and Product design
2nd Mentor: Ir. E.R. van den Ham | Climate Design and Building Physics

**Delft University of Technology**

Faculty of Architecture and the Built Environment
01. West 110
Julianalaan 134
2628 BL Delft
The Netherlands

Acknowledgements

This thesis would not have been possible without the continued support of both my mentors. Dr. Ing Thaleia Konstantinou always gave me clear instructions during the process of my thesis, while Ir. E.R. van den Ham provided me with the necessary technical knowledge for my work. In addition, this thesis has benefited significantly from a number of previous pilot projects, such as MORE-CONNECT, 2ndSkin, and Bresaer, which have provided valuable knowledge and experience in the field. I also thank my parents for their continued support of my choices and all these people who could stand me throughout this work period.

Iason Vovos



INTRODUCTION

BACKGROUND

The European Union aims to be climate-neutral by 2050 and create an economy with net-zero greenhouse gas emissions. This objective is at the heart of the European Green Deal and in line with the EU's commitment to global climate action under the Paris Agreement with the goal to transform the Union into a modern, resource-efficient and competitive economy.

The construction of buildings and their operation contribute to a large proportion of total energy end-use worldwide (Saheb 2016). The importance of this sector has led European Directive on the Energy Performance of Buildings (EPBD) to set separate goals for every new building in the residential and service sector by 2020 to be a nearly zero-energy building (Andreas Hermelink, Sven Schimschar, Thomas Boermans 2013). A nearly zero-energy (nZEB) building is a building that during a year uses nearly as much energy as it produces. Even if this directive will help the EU's goals by 2050, the existing building stock requires the same attention, as the 75% of the EU's 210 million buildings are not energy efficient, and 75%–85% of them will still be in use in 2050 (Saheb 2016).

The most energy is consumed by existing buildings while the replacement rate of existing buildings by the new-build is only around 1.0–3.0% per annum. Therefore, a rapid enhancement of energy efficiency in existing buildings is essential for a timely reduction in global energy use and promotion of environmental sustainability. (Annex50 2012). By 2050 the goal is to reduce the emissions in the building sector by 88-91%, which is the largest of all sectors. This can only be reached when all existing buildings become energy neutral with deep renovation (Konstantinou, Façade Refurbishment Toolbox 2014).

By renovating the older building stock to nZEB levels together with the legislation for the new buildings, the necessary CO₂ reduction can be achieved. The number of buildings around Europe that have to be renovated in order to achieve the goals by 2050 is around 170 million. However, there is no doubt that by applying traditional renovation methods we cannot ensure if the final intervention meets the nZEB requirements because it is difficult to monitor the entire process. Furthermore, traditional renovation techniques require extensive labor to be done on site and must assume larger risks due to human errors and damages from exposure to different conditions (outdoor forces, weather conditions, etc.) (Simona D'Oca 2018). Apart from that, the traditional way of renovation is time-consuming and requires most of the time the relocation of the occupants, a fact that would be very inconvenient on this scale and adds extra cost.

Another important point to consider is the economic factor. The individual approach of each building for renovation requires a lot of effort and costs. On the other hand, mass production it is known that reduces the production time and creates competitive prices which can be applied to the new construction of buildings. However, the European building sector has not

been able yet to devise a structural, large-scale renovation process and systematic approach. Requirements for heat loss of building envelope during deep energy renovation vary depending on requirements on indoor climate and energy performance in specific country, outdoor climate, availability of renewable energy and building typology. Prefabrication of the retrofitting components can pose the potential to achieve high performance solutions, while minimizing on-site construction time (Annex50 2012).

The most important part of the building that influences the energy consumption is the building envelope, as it is the main barrier between the exterior and the interior that influences the energy consumption related to heating, cooling, and ventilation systems.

A lot of research has been made during the last five to ten years about how we can accelerate the rate of the building's renovation, by utilizing prefabricated systems and manufacture complete façades in the factory. These approaches provide reducing construction time, costs, energy consumption, and occupants' disturbance. Many facade solutions have been developed in recent years to solve the problem of a large-scale renovation. (Sijpheer, N. C., Borsboom, W. A., & Opstelten, I. J. 2016) However, all are pilot projects and are based on a customized application approach.

SCIENTIFIC PROBLEM

Buildings are complex systems that depend on many parameters during their design but also are being influenced during their lifetime by a variety of factors. The design of each building is based on different design principles, energy demands and user's needs. This happens among buildings of the same country but even among buildings of the same neighborhood. With this as a given, it is clear that the differences in the building typologies but also in the different energy demands among the countries of Europe will be even bigger. As a result, the need to renovate almost 90% of the European existing building stock, creates a big challenge for the current construction sector as there is no standard way to approach the number of the existing buildings in need of energy improvement.

The industrialized process for new constructions is extremely mature all over Europe. The innovative solutions and competences built in this area, such as automated production lines, business models, cost optimization and sales services, are fully developed. The challenge will now be to transfer these skills and knowledge to the industrialization of the renovation market, since there is no mature industrialized approach for energy renovations yet. (Maarten De Groot 2016).

Furthermore, since the construction sector is not perceived as an easy high-profit market, there is little incentive for outside actors to enter the market of building refurbishment, take into account that the costs of deep energy renovations are often as high as the costs of demolition and new build (Maarten De Groot 2016). The challenge to create more integrated systems for nZEB renovation, is only partially answered by the building industry with the use of customized prefabricated façade elements. However, prefabricated building modules with fixed dimensions are complicated to fit into existing buildings due to all the different dimensions of the buildings.

In addition, as a continuation of the problem with the different dimensions, there is another challenge that has to be addressed, the different climatic conditions in the different European countries and the different energy needs. These two parameters create a combined problem that we need to overcome. The current state-of-the-art techniques of prefabricated façade modules cannot solve this problem because they cannot meet the mass production requirements since every example that has been applied as a pilot project is customized per building.

RESEARCH QUESTION:

“How a prefabricated facade system for energy reduction renovation of residential buildings can be designed to be adjustable in different building typologies and climates?”

Objectives:

Creating a prefabricated façade system that incorporates an adjustable support system and a series of energy reduction element that reduce energy consumption and increase thermal comfort. The structure will be designed in such a way to be applicable in different building typologies while the energy reduction components will be selected according to the energy reduction that need to be achieved.

SCOPE OF RESEARCH

The scope of this research focuses on the design of a prefabricated modular façade system that can be adaptable in different building typologies and climates. The main focus will be to create an adjustable façade system based on modular elements that could be mass-produced and easy to apply in the various building typologies and climates around Europe.

This research focuses on the adaptability of the façade system to the residential buildings, since residential buildings represent the biggest amount of floor area which is around for 70-75% (Itard, L & Meijer, F 2008) which means there is a big market to approach. In addition, residential buildings account for more than one-fourth of total energy consumption in the EU. Therefore, its impact is very important (Konstantinou, Façade Refurbishment Toolbox 2014). Therefore, this thesis will aim also to incorporate energy reduction methods with passive or active technics in the façade system that can benefit the energy efficiency of the building.

The system will be designed in such a way so that can be applied for several cases according to the main characteristics of the residential buildings in Europe. However, because it will be impossible to apply the system in every building, two case studies have been selected to validate the final result. One case study will be in a country with a cold climate and one in a country with hot climate.

CONTENTS

I Research definition

1. Introduction	5
1.1. Background	7
1.2. Scientific Problem	8
1.3. Research question and Objectives	8
1.4. Scope of Research	
2. Methodology	11
2.1. Chapter 3: Climate analysis in Europe	12
2.2. Chapter 4: Building stock in Europe	12
2.3. Chapter 5: Principles of Renovation	12
2.4. Chapter 6: Design specifications	12
2.5. Chapter 7: Case studies buildings (NL, GR)	12
2.6. Chapter 8: Design application	12
2.7. Chapter 9: Evaluation Design	13

II Literature Review

3. Climate analysis in Europe	14
3.1. Climatic zones	20
3.2. Energy consumption and climate	23
3.3. General design principles for nZEB in Europe	
4. Building stock in Europe	30
4.1. Building Age and Population	31
4.2. Building types	34
4.3. Residential building Construction Characteristics	35
5. Principles of Renovation	40
5.1. Renovation Strategies	40
5.2. Energy approach	42
5.3. Passive and Active Measures	47
5.4. Modularity and Adaptability	48

State-of-The-Art Renovation Systems

5.5. MORE-CONNECT	50
5.6. BRESAER	55
5.7. 2NDSkin Refurbishment Project	56
5.8. Evaluation of the systems	58

III Design Strategy

6. Generic Design Specifications	61
6.1. Design strategy	61
6.2. Design Principles and tools	62
6.3. Generic design Attachment variations	74
7. Case studies buildings (NL, GR)	84
7.1. Typologies and Basic Measurements	85
7.2. Current energy performance	89

IV Final Design

8. Design application in the case study buildings	94
8.1. Variations of the façade system in the building in Amsterdam	95
8.2. Variations of the façade system in the building in Athens	114
8.3. Overview of the façade system	128
9. Conclusions	134

References

137

2. Methodology

This thesis consists of five parts the three of them are based on the research. The research consists of four main activities:

Part II: Data collection and State-of-the-Art case studies research.

Part III: Formulating requirements and utilize design principle and tools to produce a generic design concept according to the literature and the case studies analysis.

Part IV: Verification of the design with its application in case studies.

This research selects and evaluates the literature on three fields of study: The context of the existing situation, the main principles related to renovation strategies, and the comparison of the state-of-the-art projects focused on solving the renovation challenges.

Afterwards, the accumulate knowledge of the literature and the analysis in the current state-of-the-art renovation approaches will contribute to formulate a design methodology consisting of a list of necessary requirements and generic design tools.

Based on the design by research methodology, several scenarios will be constructed to gain a complete idea of the necessary components that an adjustable façade system should incorporate in order to be adaptable and mass-produced. The design tools will be utilized to produce a variety of design concepts on an abstract level. Furthermore, two different combinations of components from the same system will be produced and be applied in two different case study situations for further elaboration.

The final design and the application of the design will be evaluated according to the set criteria to formulate a final answer to the research question.

Part V: Conclusions

2.1 Chapter 3: Climate analysis in Europe

Chapter 3 consists of a literature review on the main characteristics of the different climatic zones of Europe. Starting from a broad spectrum to a more detailed one by analyzing two countries as case studies from different climatic zones. Additionally, research is carried out related to energy consumption and energy resources in Europe. The aim of this chapter is to define the appropriate functions that the new renovation system will incorporate related to the different climates in Europe.

2.2 Chapter 4: Building Stock in Europe

Chapter 4 consists of a literature review on the current situation of the European building stock in order to define what are the potential buildings to be renovated, what are the types, and which of them are more suitable and provide similar characteristics for a big-scale renovation.

2.3 Chapter 5: Principles of Renovation

Chapter 5 consists of a literature review on the principles associated with renovation. It describes the approaches and measures available to reduce energy consumption. Also, a series of examples from the current state of the art façade systems for renovation is presented to assess the advantages and disadvantages of each method and help to define the principles for the new adjustable façade system for energy reduction renovation.

2.4 Chapter 6: Generic Design specifications

Chapter 6 consists of the accumulated knowledge from the literature review and the case study analysis of the current best practices renovation systems are combined, to formulate a list of criteria in order to define the design principles and tools that should be integrated into the new facade system for different climates and building typologies in order to render it adjustable.

2.5 Chapter 7: Case studies buildings (NL, GR)

Chapter 7 consists of the analysis of two case study buildings that will be used to apply the concept design on. The buildings not only are located in different locations with different climatic characteristics but also have different building characteristics and functions.

2.6 Chapter 8: Generic Design application and validation of the system

In chapter 8 the final design is applied to the case study buildings and further elaborated with sections, elevations, and details. Two separate scenarios are constructed based on the different characteristics of the climates and typologies. This way two different combinations of the same façade system are presented in detail, one for cold climate and one for hot climate. During

the process of the application of the facade system for energy reduction, different parameters take into account and different variations of the system are selected according to building characteristics, functions, and climate. As a result of this process, the generic design is being validated for its adjustability properties.

2.7 Chapter 9: Conclusions

This final chapter provides an answer to the main research question, based on the process that has been followed to define the final adjustable facade system for energy reduction renovation.

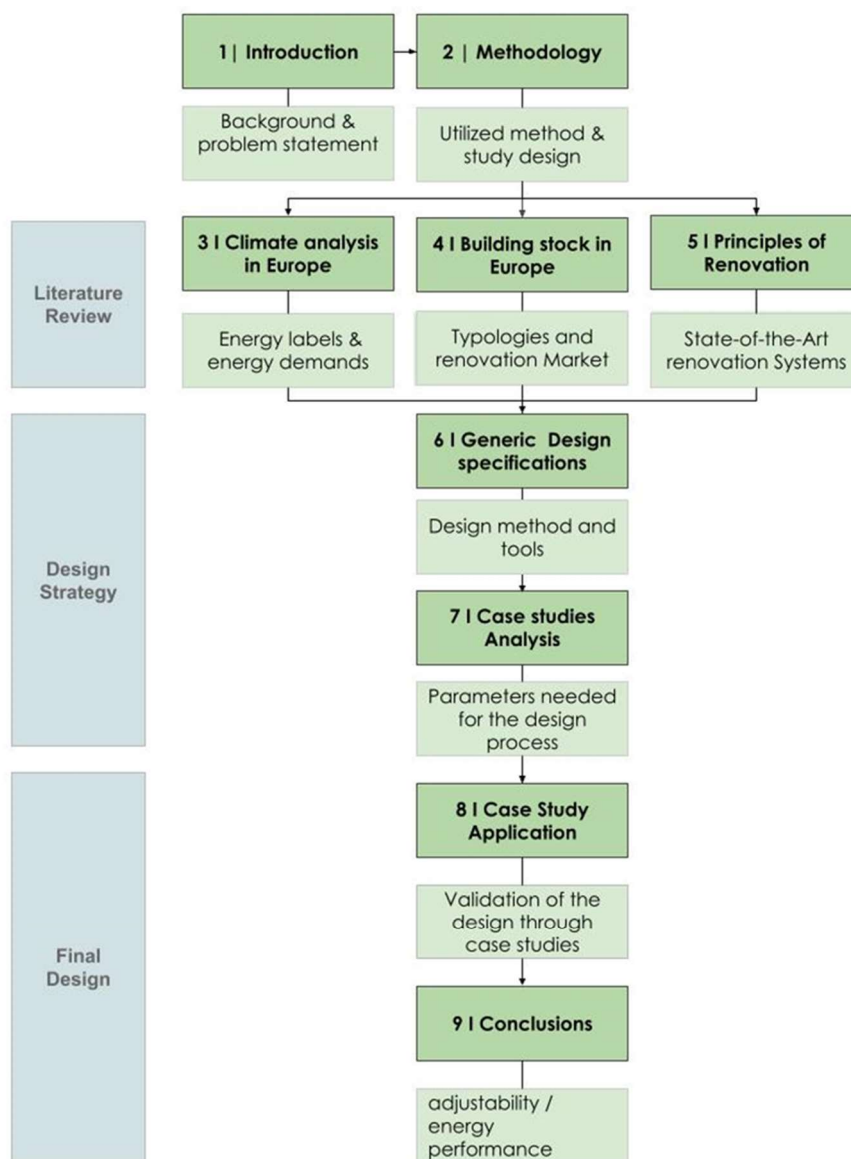

3. Climate analysis in Europe

In this chapter, the main characteristics of the different climatic zones of Europe are presented in order to see the climatic challenges that the prefabricated facade system will face in a potential renovation of a building.

The weather condition of a region plays a very crucial role in building construction as it is the main factor that influences the indoor climate and the energy consumption of the building. Having as a given the creation of an adjustable system for facade building for renovation around Europe, the recording of the different climates is of paramount importance.

An analysis will be conducted starting from a broad spectrum of the climate in Europe and conclude with a more detailed one, with further elaboration on the climate of two countries, one from the central-north part of Europe and one from the South.

In addition, a research is carried out related to energy consumption and energy resources in Europe. Furthermore, the principles of the energy certificates in buildings is presented.

3.1 Climatic Zones

A general approach to evaluate the different weather conditions in Europe is the temperature. With a quick look at the average temperatures, we can understand the general climatic situation of each region. Therefore, two examples are presented, one that shows the average temperature in Europe during the winter and one during the summer. The online tool that has been used to depict these results is the *JRC MARS explorer*.

Average Daily Temperature

Averaged values

from : 21 January 2020
to : 31 January 2020

Year of interest (CUR)

Unit: degrees Celsius

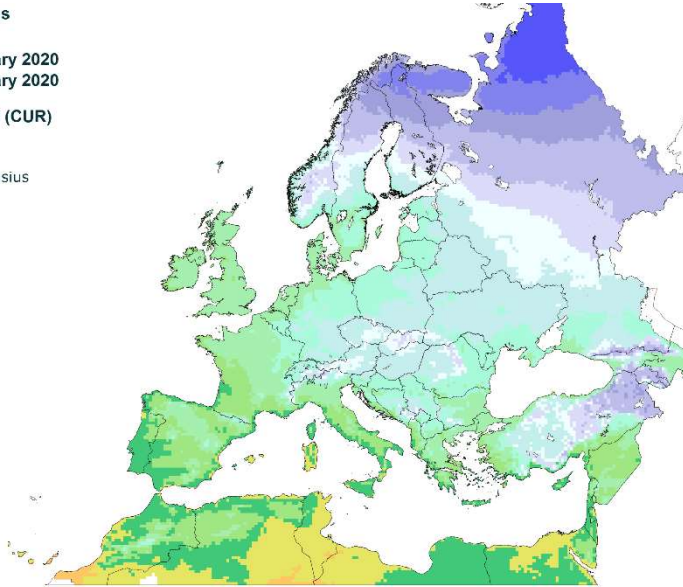
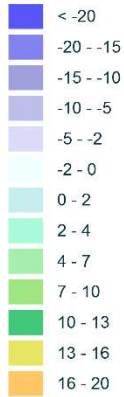

Figure 1

Averaged values

from : 21 June 2020
to : 30 June 2020

Year of interest (CUR)

Unit: degrees Celsius

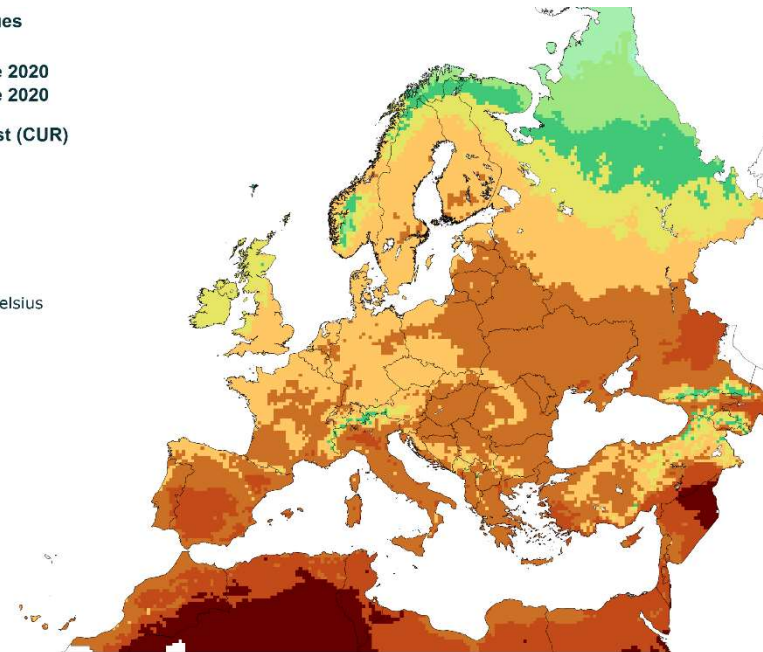
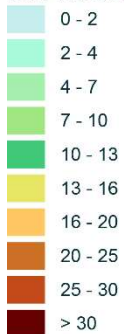

02/07/2020
resolution: 25x25 km



© European Union 2020
Source: Joint Research Centre (JRC MARS4CAST)

Figure 2, Source: <http://www.marsop.info/>

The two figures above show that the average temperature between the central-north countries and the countries in the south have around 10 degrees' difference in both time periods scenarios. However, these results are

only to indicate that there is no specific climate in Europe and subsequently none of the European countries has in its whole area one kind of climatic condition. For instance, in Italy there is a large temperature difference from southern to northern Italy with temperatures from (-2) to 16 Celsius in the period 21-31 of January. However, we cannot be based only on the temperature to define the climate, many other parameters are also very important such as humidity and solar radiation.

Many attempts have been made during the years to classify the different climates. The most widely used general climate classification is the Köppen-Geiger system. This system was originally developed by Wladimir Köppen around 1900. First versions were based on previous maps of vegetation growth, but it has subsequently been revised and gave more weather data. The map shows that countries may have more than one climatic zone and it is sometimes difficult to establish the prevailing climate classification of Köppen. (BEAR 2016)

The map in figure 3 and the graphs in figure 4 show the variation of the different climates based on the Köppen classification. It is clear that most of the countries in Europe belong in the mild cold climate condition which is generally the north-central countries, following by the mild warm climates with the southern countries.

Subdivision of climate conditions based on the Köppen-Geiger scale for the selected locations in Europe.

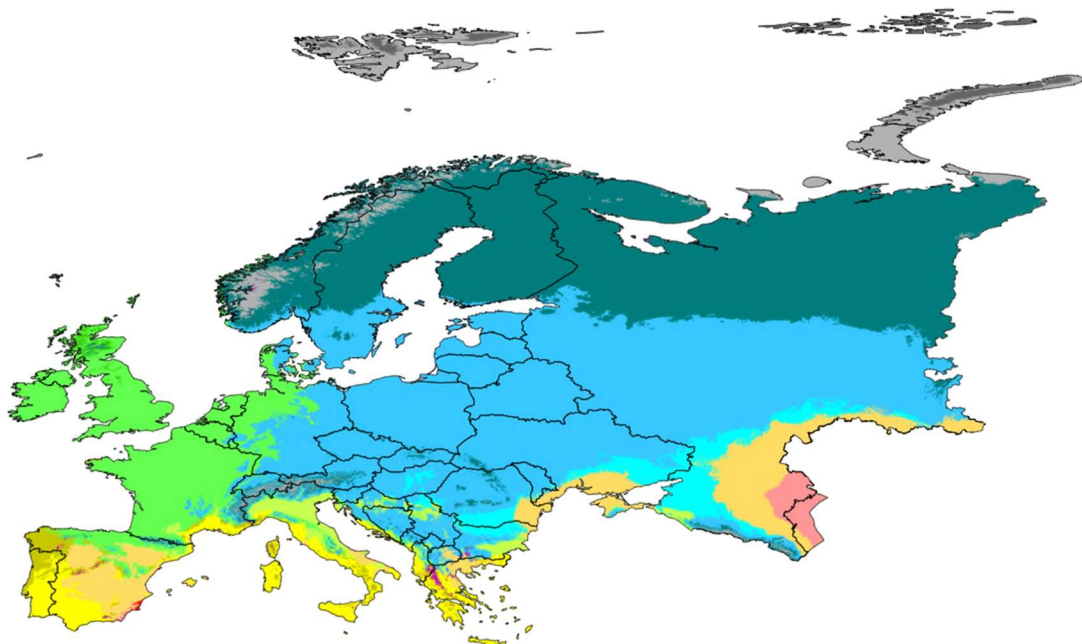

Figure 3, Köppen-Geiger climate classification map for Europe (1980-2016)

- Arid, desert, hot (BWh)
- Arid, desert, cold (BWk)
- Arid, steppe, hot (BSh)
- Arid, steppe, cold (BSk)
- Temperate, dry summer, hot summer (Csa)
- Temperate, dry summer, warm summer (Csb)
- Temperate, dry summer, cold summer (Csc)
- Temperate, no dry season, hot summer (Cfa)
- Temperate, no dry season, warm summer (Cfb)
- Temperate, no dry season, cold summer (Cfc)
- Cold, dry summer, hot summer (Dsa)
- Cold, dry summer, warm summer (Dsb)
- Cold, dry summer, cold summer (Dsc)
- Cold, no dry season, hot summer (Dfa)
- Cold, no dry season, warm summer (Dfb)
- Cold, no dry season, cold summer (Dfc)
- Polar, tundra (ET)
- Polar, frost (EF)

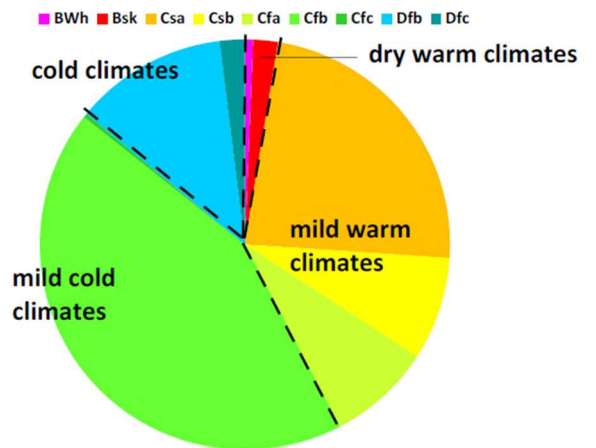

Figure 4, source: A Database for Climatic Conditions around Europe for Promoting GSHP Solutions (2018)

A further analysis has been carried out for each country in order to see the differences in the climate depending on particular conditions. The figure below shows the overall results, listing the climate conditions per country from the warmest climates to the coldest climates. This provides a quick overview on what can be expected in a certain country in terms of climate conditions and hence as potential for heating and/or cooling. (Michele De Carli, 2018)

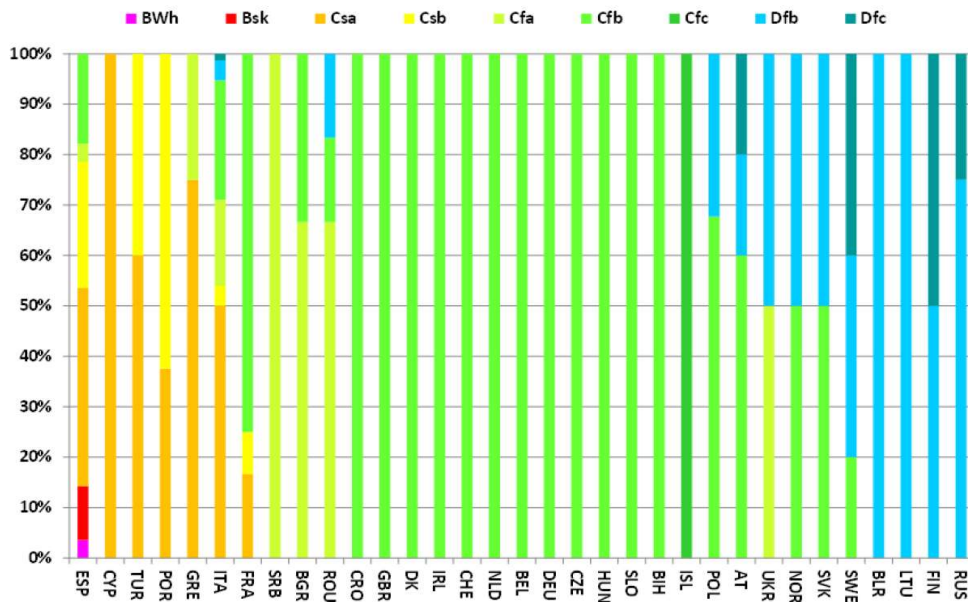

Figure 5 source: A Database for Climatic Conditions around Europe for Promoting GSHP Solutions (2018)

A very crucial aspect which is related with the climate and weather conditions is the heating and cooling degree days. The term heating or cooling degree days (HDD or CDD) is defined as the positive deviation of the mean monthly temperature T_m from a base temperature T_b , below (or above) which heating or cooling is needed to sustain the indoor temperature to a comfortable level.

$$\text{HDD (or CDD)} = \sum_{i=1}^{12} |T_m - T_b|$$

The formula gives the value of quantity and duration when the air temperature becomes lower or higher than a determined threshold value, which is known as base temperature (Hitchin 1981). The base temperature depends on the construction characteristics of the building. For heating, the traditional base temperature for the degree-day (HDD) is considered around 18 °C.

On the other hand, the base temperature to calculate the cooling degree days (CDD) is 23 °C. It would be more appropriate to use a lower value of CDD for northern climates, due to the increased thermal protection and air tightness of the building envelope, allowing for less heat flows between the interior and the exterior environment. (Katerina Tsikaloudaki 2011)

As it has been shown in the map of Koppen classification, climatic conditions are very difficult to be defined due to the complexity of the subject. However, the main concern in this thesis is not to define the climate of Europe but to define the needs of the building related to the climate. For this reason, a better way to combine the building and the climate as points of interest is the degree days' approach. In the graphs below is illustrated the deviation from the mean temperature around Europe and the need for heating and cooling that each country needs for the cold and hot months of the year.

Time series of heating and cooling degree days averaged over Europe.

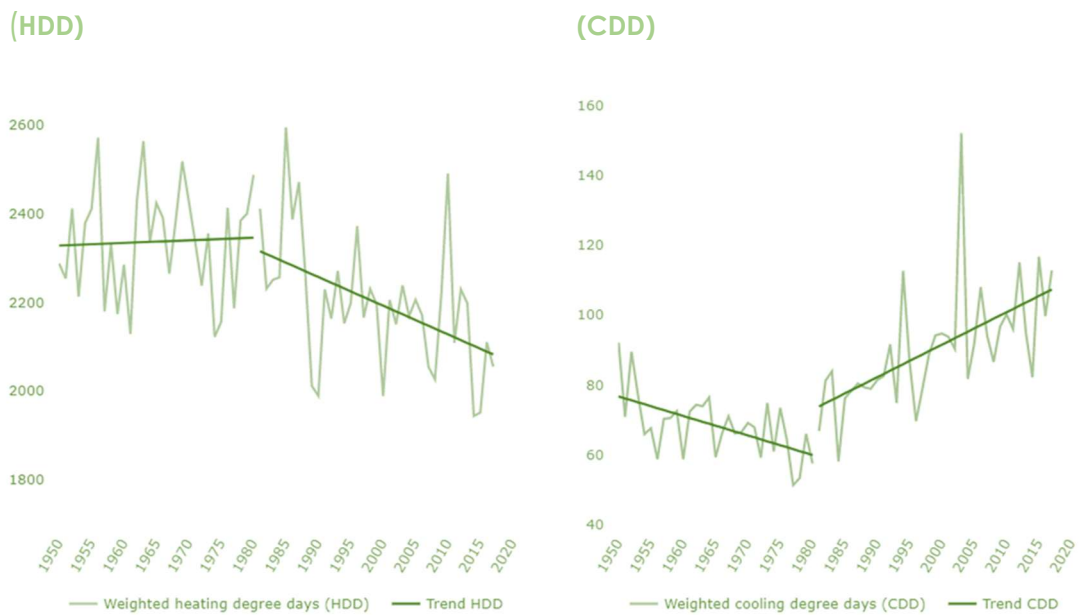

Figure 6, Source: <https://www.eea.europa.eu>

The figure 6 above depicts that HDDs and CDDs do not show a clear trend in the period 1950–1980. On the other hand, at the beginning of the 1980s, Europe has started experiencing a significantly declining overall trend in HDDs, and a remarkably increasing trend in CDDs, which means a general the need for cooling increased and the need for heating decreased.

Observed trend in heating and cooling degree days (1981-2017)

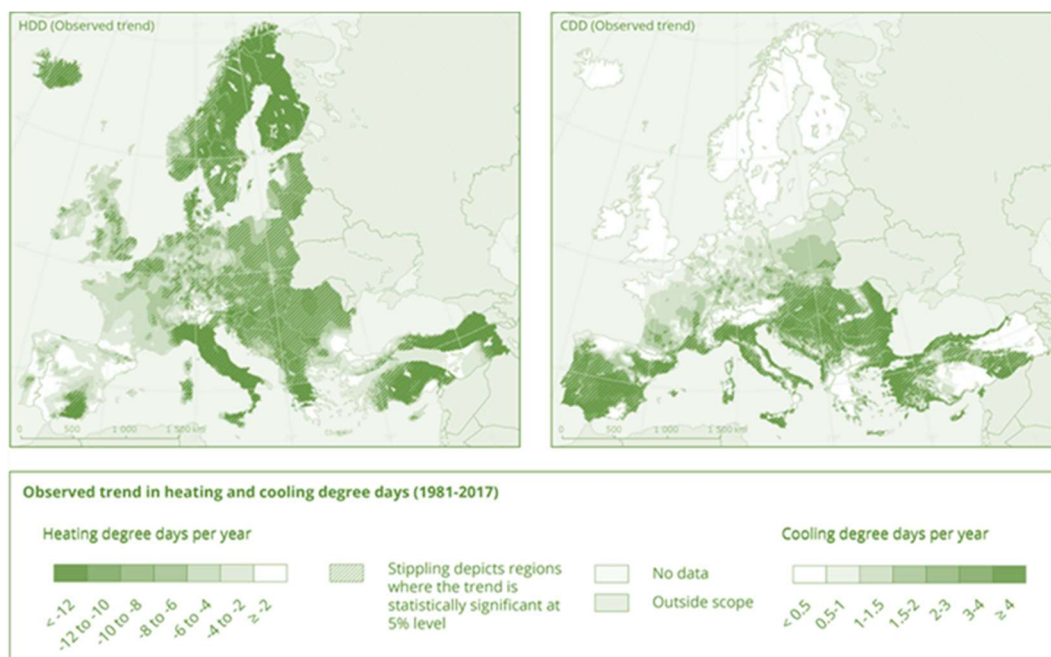

Figure 7, Source: <https://www.eea.europa.eu>,

In addition, the maps in figure 7 illustrate that the decrease in HDDs has been particularly strong in northern Europe, where the energy demand for heating is highest. The right map shows that the increase in CDDs has been particularly strong in southern Europe where the energy demand for cooling is highest.

3.2. Energy consumption and climate

Out of the total energy available in the EU, around two thirds are consumed by end users, for example industry, households, citizens, etc. see figure 8. Around one third is lost during electricity generation and the distribution.

It is necessary to define the primary and secondary energy between products. A primary energy product is extracted directly from natural resources, such as crude oil, firewood, natural gas or coal. Regarding the secondary energy products such as electricity and motor gasoline is a result of a transformation process, either from a primary or from a different secondary energy product.

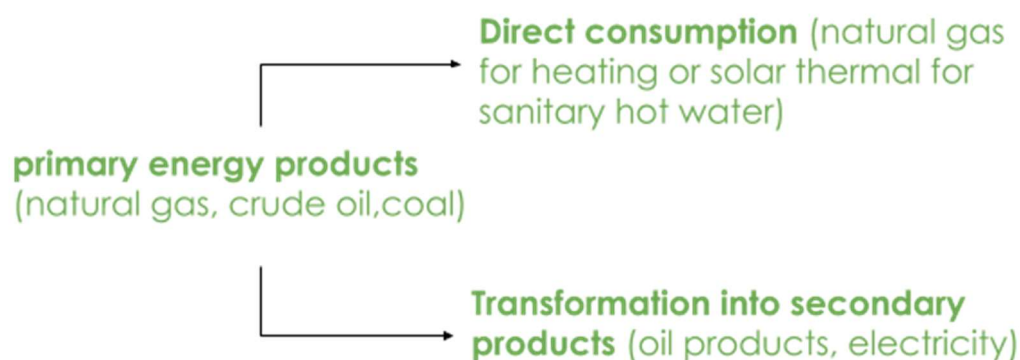

In the EU in 2018, petroleum products such as heating oil, petrol, diesel fuel, which represent 41 % of final energy consumption were the most consumed, followed by natural gas and electricity (both 21 %) and direct use of renewables (not transformed into electricity, e.g. wood, solar thermal, geothermal or biogas for space heating or hot water production) (10 %), derived heat (such as district heating) (4 %) and solid fossil fuels (mostly coal) (3 %).

The real consumption of renewable energy is higher than 10 %, because other renewable sources are included in electricity (e.g. hydropower, wind power or solar photovoltaic). (Eurostat, 2020)

ENERGY CONSUMPTION BY SECTOR EU-27, 2018

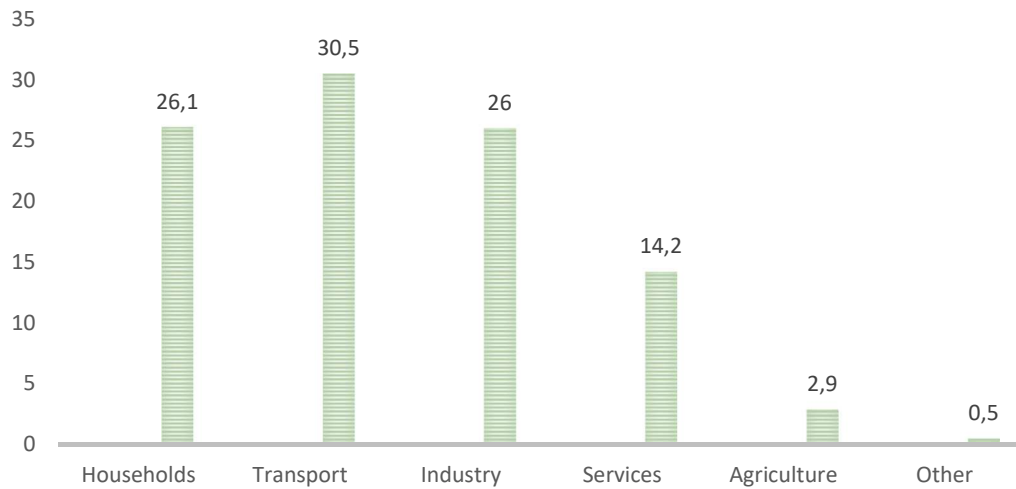

Figure 8, Source: Eurostat (online data code: nrg_bal_s)

There are large variations in building energy performances and consumption in the European countries, see figure 9. A consumption of 458 Mtoe in 2016, building stock account for 41% of the total energy consumption and 60% of the electricity consumption in Europe. Two thirds of this consumption are for residential buildings. (Rousselot 2018). In figure 10 shows that the energy in dwellings is consumed for heating, cooling, cooking, domestic hot water and appliances. Space heating is the most intense end-use in European households, reaching up to 70% (Konstantinou, Façade Refurbishment Toolbox 2014).

CONSUMPTION OF RESIDENTIAL BUILDINGS FOR SPACE HEATING IN (MTOE) FOR THE YEAR 2018

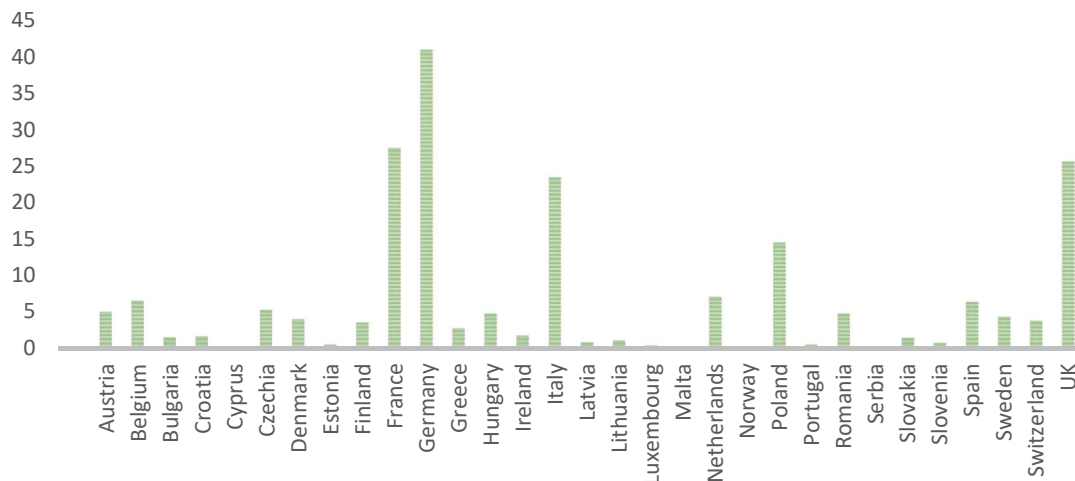

Figure 9, Source: ODYSSEE

The percentage in energy consumption for space heating in southern Europe is generally less than the northern countries during the winter period because of the warmer climate. However, according to BPIE survey (E. B. BPIE 2011) buildings built in 1950s in Italy have an average consumption for heating

similar with buildings of the same period in Germany which means that performance and energy efficiency of these buildings are not sufficient for both climates. Household energy efficiency has improved by 28% at EU level since 2000 due to more efficient heating systems and buildings. (Rousselot 2018)

ENERGY CONSUMPTION IN DWELLINGS

■ space heating ■ water heating ■ cooking ■ electric appliances

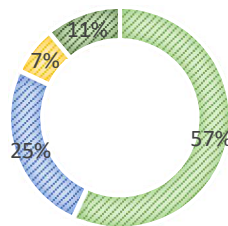

Figure 10, Source: BPIE survey

Figure 11 illustrates that gas is the most common fuel that is used in buildings in North-West countries while oil use is the highest in Southern Europe. Coal for the residential sector is used by Central & Eastern Europe where also district heating has the highest percentage of all regions. Renewable energy have a share of 21%, 12% and 9% in total final consumption in Central & Eastern, South and North & West regions, respectively. (E. B. BPIE 2011)

ENERGY IN RESIDENTIAL BUILDINGS BY REGION

■ South ■ Central&East ■ Noth&West

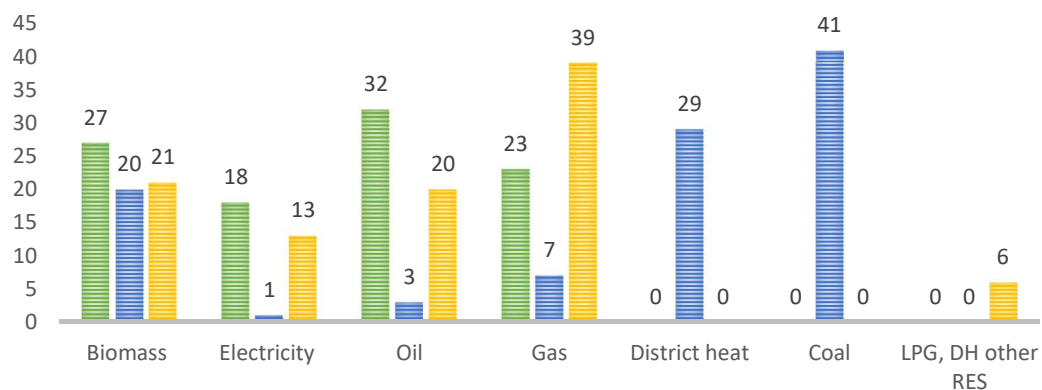

Figure 11, Source: (E. B. BPIE 2011)

As far as the distribution of the energy consumption in dwellings is concerned, the biggest influencers are space and water heating. However, electrical appliances represent the 11% of the total energy consumption. Even though

that the overall gas use has declined through the decades the overall energy consumption has increased due to the increased use of electrical appliances and the increased living standards around Europe.

3.3. General design principles for nZEB in Europe

In this section, information is presented where the climate characteristics of the Koppen-Geiger climate classification that showed previously, combined with another categorization made by ECOFYS, where the climates are divided into five climatic zones based on the weather characteristics. Specific cities have been selected to represent each zone that corresponds with a particular climate category from Koppen. The correlation between these two approaches of climatic condition will form general guidance in order to determine the general design principles and appropriate technologies for the different European regions in order to create an nZEB in these climates.

As it was mentioned from many sources in the literature, the climate and the environment affect the condition of the building, therefore will determine the energy consumption and the thermal insulation characteristics. The thermal behavior of the building at the same time, is determined by selection of technologies, materials, concepts or refurbishment techniques to be used in facades in order to guarantee their energy efficiency. (BEAR 2016)

Zone	Cities	Koppen
Zone 1	Athens - Larnaca - Luga - Catania - Seville - Palermo	Csa
Zone 2	Lisbon - Madrid - Marseille - Rome	Csa /Cfb
Zone 3	Bratislava - Budapest - Ljubljana - Milan - Venice	Dfb
Zone 4	Amsterdam - Berlin - Brussels - Copenhagen - Dublin - London - Macon - Nancy - Paris - Prague - Waszawa	Cfb/Dfb
Zone 5	Helsinki - Riga - Stockholm - Gdansk - Tovarene	Dfc

Table 1, Source: (BEAR 2016)

Table 2, Source: (BEAR 2016)

Building strategies in different climates		
KOPPEN	ECOFYS	nZEB typology
Csa - Hot and dry climate	Zone 1&2 - Temperate with dry, hot summer. (Mediterranean climate)	Well-insulated building envelope with limited fenestration area; glazing with very low SHGC and shading from direct sunlight in summer; reflective or cool colors exterior envelope surfaces essential (colors with low heat absorption to reduce the solar load during the summer period) ; solar powered AC equipment can provide day-time cooling; thermal mass and lower night-time temperatures provide comfortable indoor conditions after sunset (nocturnal ventilation)
Dfb - Warm and humid climate	Zone 3 - Temperate continental climate/humid continental climate without dry season and with warm summer;	Moderately insulated building envelope with limited fenestration area having low SHGC and effective shading devices; green (vegetated) roofs and/or reflective exterior envelope surfaces are beneficial; since the removal of latent heat (water vapor) matches the energy required for sensible cooling, investing in sophisticated ventilation is essential to provide healthy and comfortable indoor air conditions without wasting energy.
Cfb - Temperate climate	Zone 4 - Temperate without dry season and warm summer	Well-insulated building envelope with energy efficient fenestration (very low to low U-value, moderate to high SHGC- depends on glazing area); operable shading systems required to prevent summer over-heating; thermal mass and balanced ventilation with heat recovery is beneficial. Nocturnal ventilation
Dfc - Cold climate	Zone 5 - Cold, without dry season and with cold summer.	Compact building design with very well- insulated building envelope components; total fenestration area should be limited with very low U-value and high SHGC (solar heat gain coefficient); thermal mass and balanced ventilation with heat recovery is essential.



zone 1 & 2 zone 3 zone 4 zone 5

Climatic zones according to ECOFYS source: BEAR, (2016)

The climate conditions that mainly affect the specific energy consumption:

- external air temperature
- wind velocity and direction
- solar radiation
- Infrared radiation.

Even though this survey contributes to creating a general perspective about the necessary requirements for a nZEB in Europe's climates, further analysis has to be done to specify the exact variables of each location. Building's location has very particular climate variables. Taking this as a given and wanting to specify the climate where the case study buildings are located, it is chosen to further analyze the climate in Amsterdam, the Netherlands, and the climate in Athens, Greece.

Based on the tables 1 and 2 can be concluded that the general nZEB strategies for the buildings in Amsterdam and Athens are:

Amsterdam: Well-insulated building envelope with energy efficient transparent surfaces with very low to low U-value, medium to high solar heat gain coefficient (SHGC) depends on glazing area). Additionally, operable shading systems required to prevent summer over-heating, thermal mass and balanced ventilation with heat recovery is beneficial.

Athens: Well-insulated building envelope with limited fenestration area, glazing with very low (SHGC) and shading from direct sunlight in summer, reflective or cool colors exterior envelope surfaces essential colors with low heat absorption to reduce the solar load during the summer period, solar powered AC equipment can provide day-time cooling, thermal mass and lower night-time temperatures provide comfortable indoor conditions after sunset.

The aim of this thesis is to design an adjustable façade system that can be applied in different climates and building typologies. Therefore, the selection of these two climates contributes to define the exact climate characteristics that the system has to be adjustable.

To specify the particular climates in these two locations the *Climate consultant 6.0* software is used to extract the data. At this stage three variables are selected to define the differences between the two climates: the percentage of indoor comfort with passive techniques, the cloud cover average and the sun shading hours.

According to the data from the Climate consultant, in Amsterdam, it is possible to live indoors without using energy to balance the temperature in comfort levels in 40% of the year. However, this percentage is valid only when the building uses properly the passive design principles.

On the other hand, in Athens, the percentage for the same situation is 63%. As a result, in Amsterdam, is needed around 20% more energy to keep the indoor climate in comfort levels.

PERCENTAGE OF INDOOR COMFORT BY USING ONLY PASSIVE TECHNIQUES

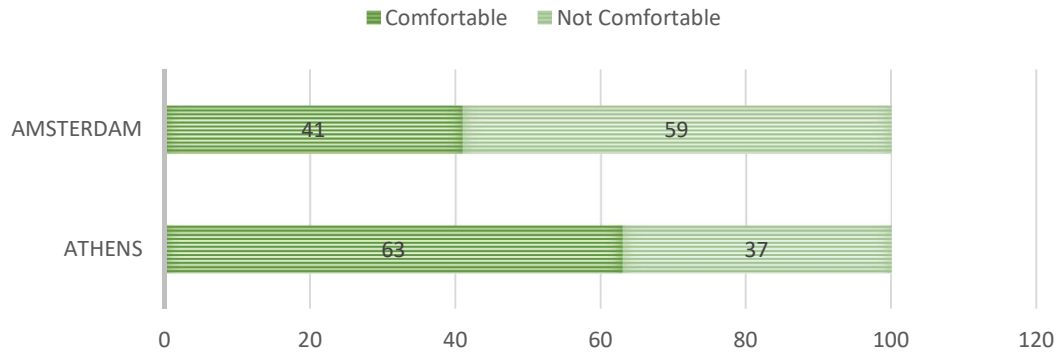

Figure 12 Source: climate consultant 6.0

Another important factor that has to be taken into account is the cloud coverage in both climates in the potential use of solar panels in the façade system.

AVERAGE CLOUD COVER

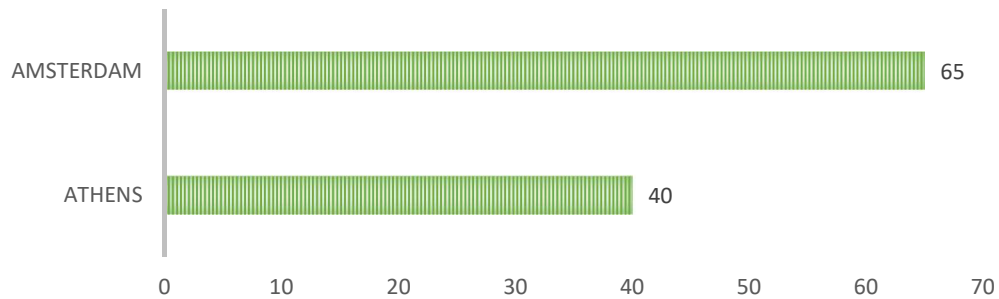

Figure 13, Source climate consultant 6.0

As the above diagram in figure 13, 65% of the year the sky is covered with clouds in Amsterdam and 40% in Athens respectively. However, the period from June to September the average cloud cover is only 15% in Athens while in Amsterdam the period from December to February is 75%.

HOURS EXPOSED
DATA FROM SUNSHADING CHART

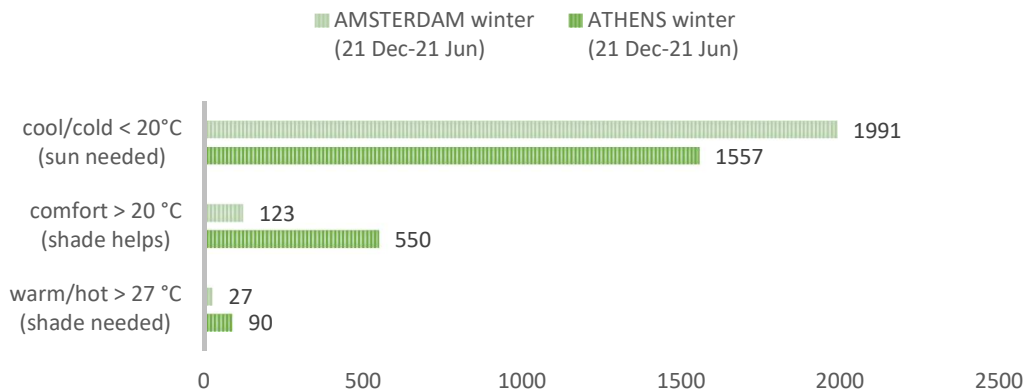

Figure 14, Source: climate consultant 6.0

According to the chart in figure 14, during winter in Athens 640 hours of shade is needed while in Amsterdam only 150. On the other hand, the need for the sun is much higher in Amsterdam as the average temperature during winter is lower than in Athens.

HOURS EXPOSED
DATA FROM SUNSHADING CHART

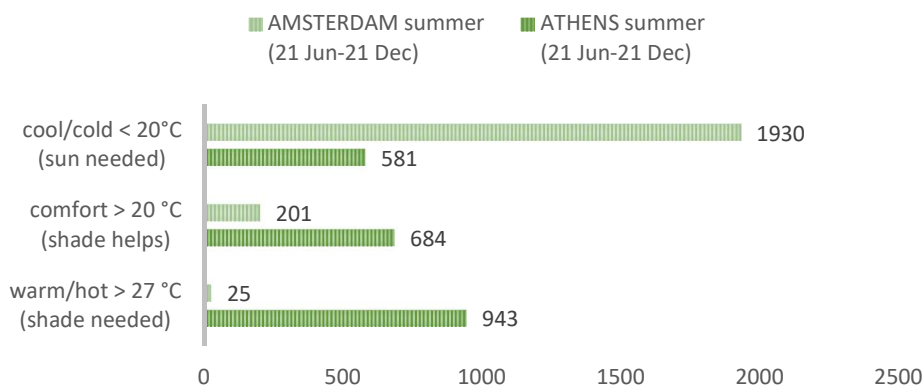

Figure 15, source: climate consultant 6.0

In summer period, the variables in figure 15 are different, as in Athens the need for shading is much higher because most of the time, the temperature is more than 27 °C. In contrary to Amsterdam, the temperature most of the time is less than 20 °C, and the sun is needed.

The overall result from the data above shows that in Amsterdam the energy consumption is due to the need for heating to keep the indoor climate at comfortable levels annually. On the other hand, in Athens, where the climate is not so cold, heating is still needed during winter. As far as the summer period is concerned, in Athens, the need for cooling is an undeniable fact something that in Amsterdam is not a case.

	Athens (warm climate)	Amsterdam (cold climate)
1	Well insulated buildings to keep the heat gain from people, lights and equipment inside.	Glazing should minimize conductive loss and gain (minimize U-factor). Solar radiation has less impact in this climate.
2	For passive solar heating face most of the glass area south to maximize winter sun and add overhangs for shading in the summer.	For passive solar heating face most of the glass area south to maximize winter sun and add overhangs for shading in the summer.
3	Operable walls and shaded outdoors.	Well insulated buildings to keep the heat gain from people, lights and equipment inside.
4	Double pane high performance glazing with Low-E on west, north and east but clear in south for passive solar gain.	Sunny wind protected outdoor spaces can extend living areas in cool months.
5	Good natural ventilation can eliminate air conditioning.	Low mass, well insulated, tightly sealed construction to provide rapid heat buildup in the morning.
6	Shading to prevent overheating during summer, use passive solar gain in winter.	High performance furnace
7	Low pitched roofs and wide overhangs	Steep pitched roof with vented attic over a well-insulated ceiling
8	Window overhangs or operable sunshades can eliminate AC	Extra insulation increases occupants comfort by keeping indoor temperature more uniform.
9	Sunny wind protected outdoor spaces can extend living areas in cool months.	Exterior wind shields can protect from cold winter winds.
10	Use high mass interior surfaces to store winter passive heat and summer night coolth.	Use high mass interior surfaces to store winter passive heat and summer night coolth.
11	Screened porches provide passive comfort cooling through ventilation in warm weather.	Vestibule entries to eliminate drafts in windy sites.
12	Light colored building materials to minimize conducted heat gain.	Heat recovery ventilator to ensure indoor air quality for super tight buildings.

Table 3, variation in construction and design principles based on warm and cold climate. Source: climate consultant 6.0

In table 3 it is showed the necessary design and construction guidelines to achieve thermal comfort during the whole year in Athens and in Amsterdam It was decided that the first location will represent the warm climates and the second location will represent the cold climates. The list starts with the most important factors first based on the Psychrometric Chart in the climate consultant software. One third of the overall design principles for both climates is common, and it is illustrated on the table with the different line types. The main design difference between the two climates is that in the case of Athens more shading is needed for sun protection, while in Amsterdam more insulation is needed for cooling protection.

Further elaboration related to the climate design principles is conducted based on table 3 with the aim to define the properties that the façade renovation system for energy reduction has to incorporate. Therefore, a new categorization on table 4 is created, in order to determine more simplified the design principles for warm and cold climates.

Table 4, categorization of the design principles in warm and cold climate.

Warm Climate	Cold Climate
Operable and movable surfaces for shading (overhangs, awnings, louvers)	Wind shields
Perforated surfaces for shading and ventilation.	Heat recovery ventilator to ensure indoor air quality for super tight buildings.
Insulation	Insulation
Glazing with low-E	Glazing with very low U-value
Surfaces with high thermal capacity.	Surfaces with high thermal capacity.

Based on the data in table 4 a further distinction is necessary to divide the design requirements into functions that the façade system will include. The functions can be seen in table 5.

Table 5, categorization based on functions

Passive functions	Active functions
Operable and movable surfaces for shading (overhangs, awnings, louvers).	Room for ventilation ducts of the heat recovery ventilator.
Perforated surfaces for shading and ventilation.	Room for other electrical installations (PV etc.)
Insulation	
Glazing with low-E and low U-value.	
Surfaces with high thermal capacity.	
Wind shields	

The result of this analysis shows that there are more passive functions to increase thermal indoor comfort, than active ones. This means that the renovation facade system will incorporate in most cases technics that do not use energy to perform. However, if there is a need for better energy performance and further energy reduction, active measures have to be included.

Conclusions

Chapter 3 presents a data collection from different sources and perspectives in order to understand the differences between the climates and the energy consumption in Europe. Further analysis showed that each country uses different energy resources and the energy consumption varies due to the different energy needs.

This step was necessary as the system that we aim to design has to be adaptable in different climate conditions and will integrate technology that aims to reduce energy consumption according to the outdoor climate. The selection of two climates with different characteristics (Netherlands and Greece) was made with the aim to evaluate the applicability of the system in different weather conditions.

The last part of this chapter concludes with the main design principles that are necessary to include in the façade system according to the climate characteristics.

In the next Chapter the building stock of Europe will be analyzed, with the aim to find the characteristics that a building has to have, for the renovation facade system to be applied.

4. Building stock in Europe

From many perspectives, buildings have a very important role in our lives and society as a whole. They not only form our urban environment but also work as a backdrop in our daily habits. However, buildings are very complex objects that incorporate an energy performance identity except for their architectural character. The energy performance of the buildings is generally so low that the levels of energy consumption buildings render the building sector as the most significant CO₂ emissions sources in Europe.

Having the refurbishment of the existing building as a method to reduce the greenhouse gas emissions it is necessary to analyze building sector. For this reason, in this chapter it will be analyzed the European building stock in terms of age and population, types and construction characteristics.

4.1 Building Age and Population

While new buildings can be constructed with high performance levels, the older buildings represent the majority of the building stock, which is primarily of low energy performance and in need of refurbishment. The potential to achieve high energy and CO2 savings by transforming the existing European building stock in energy efficient can play a crucial role in a sustainable future.

It is estimated that there are around 25 billion m² of useful floor in Europe. Half of the total estimated floor space is located in the North & West region of Europe while the remaining 36% and 14% are contained in the South and Central & East regions, correspondingly. According to the BPIE survey the European countries have been divided based on climatic, building typology and market similarities into three regions.

The North & West region consists of: Austria, Belgium, Switzerland, Germany, Denmark, Finland, France, Ireland, Luxemburg, Netherlands, Norway, Sweden, and United Kingdom with total population around 281 million.

The Central & East region consists of: Bulgaria, Czech Republic, Estonia, Hungary, Lithuania, Latvia, Poland, Romania, Slovenia, Slovakia with population 102 million.

The South region consists of: Cyprus, Greece, Spain, Italy, Malta, Portugal with population around 129 million.

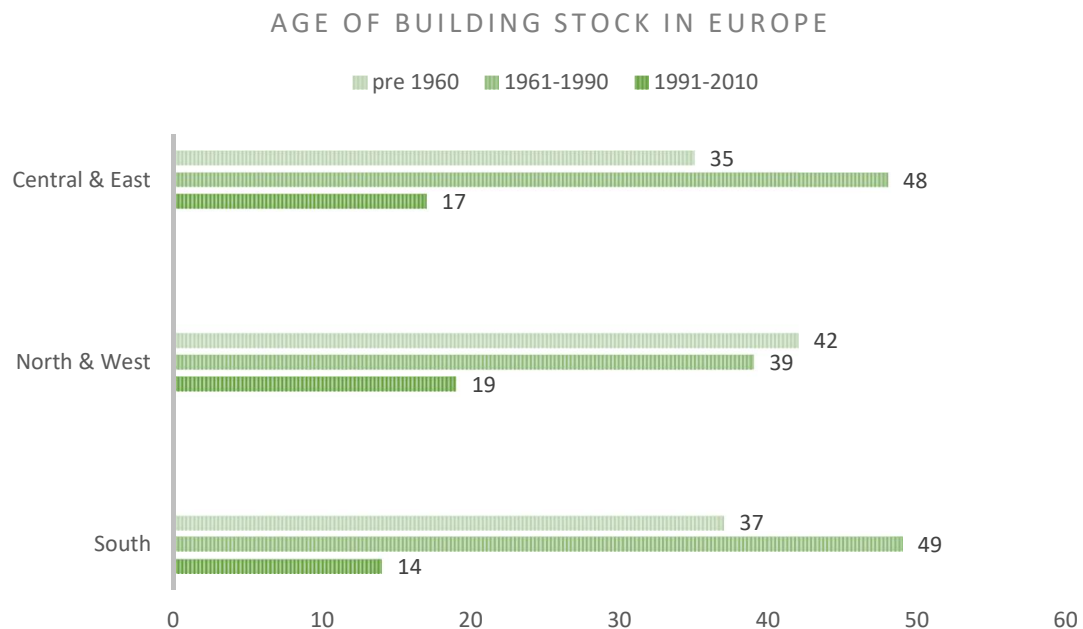

Figure 16. Source: BPIE survey

As we can see from the graph in figure 16 there are differences among the population and the age of the buildings in these regions. First of all, there is a general decrease over time in terms of building construction. Furthermore, in the North and West region the percentage of the buildings before 1960 is higher than the one which represents the buildings between 1961-1990. On the other hand, in Southern as well as in the Central & East Europe, the numbers have different values. The percentages of the buildings that have been built before 1960 are lower than the period until 1990.

From the above information we conclude that because of the large total number of buildings in the North-West region and the high percentage in buildings before 1960, the number of buildings that belong in this period is 118 million. In the two other regions the number of buildings is 47 million for the south and 35 million for the Central-East respectively. This can be translated that the North-West countries according to the BPIE survey have approximately 36 million more houses that have been built before 1960. An important factor that we have to take into account which is related to the energy efficiency of the buildings, is that most of the national building regulations that applied thermal insulation of building envelopes were introduced after the 1970s because of the energy crisis (Konstantinou, Façade Refurbishment Toolbox 2014).

As far as the ratio of the building types is concerned, the residential buildings account the 75% of the total stock in Europe and comprise a simpler and more homogenous sector compare to the non-residential sector, see figure 17. The non-residential buildings in comparison to the residential ones involve more complexity in many ways because of the variation of construction techniques or energy intensity and special functions. (E. B. BPIE 2011)

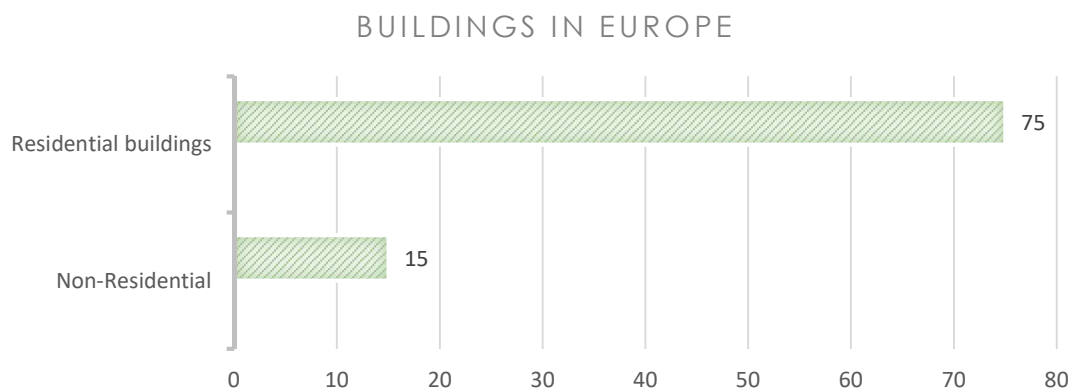

Figure 17, Source: BPIE survey

Each section of the above graph consists of subsections of different building types and functions. According to the BPIE survey in figure 18 most of the residential buildings are single family houses and the rest are apartment blocks. On the other hand, the non-residential buildings have more subsections and can be seen in figure 19.

RESIDENTIAL BUILDING STOCK (M²)

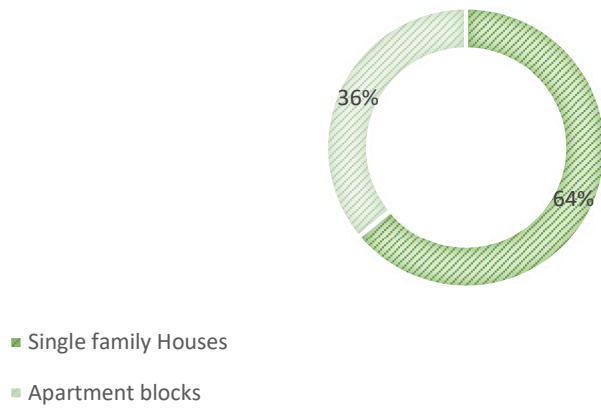

Figure 18, Source: BPIE survey

NON-RESIDENTIAL BUILDING STOCK (M²)

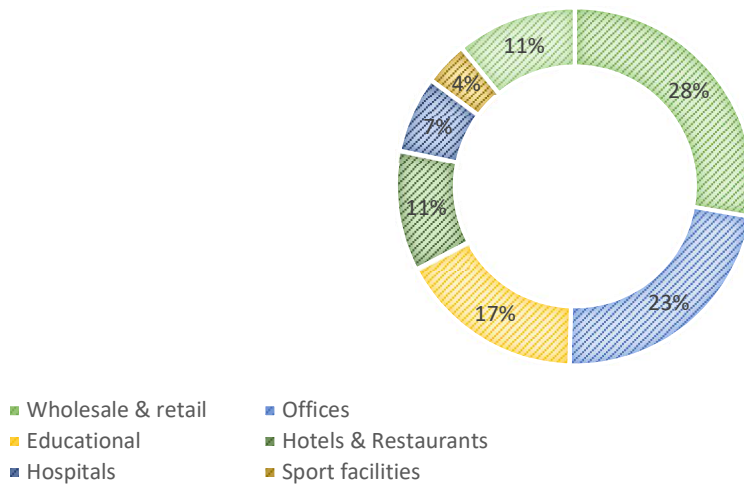

Figure 19, Source: BPIE survey

4.2 Building Types

It is quite clear from the aforementioned data that the residential sector has more potential to be the field where the construction sector has to be involved in order to gain more profit and subsequently to enhance the quality in the building sector and reduce the CO₂. What makes the residential stock the right choice for the construction sector to interfere, is the large amount of buildings, in comparison with the non-residential ones, but also the simpler building character from structural, functional and architectural perspective of the residential buildings that leads in more easy solutions to apply.

Residential buildings can be categorized in single-family houses, multi-family houses and terraced houses. This distinction will be used in order to understand further the individual characteristics of this category.

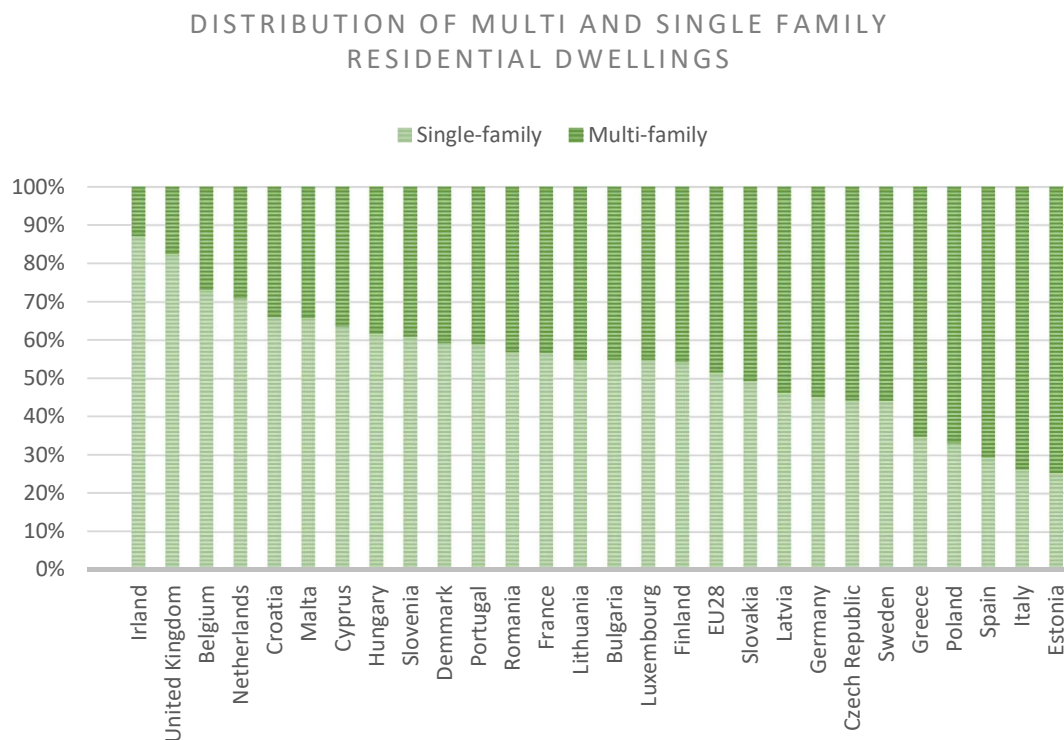

Figure 20, Source: Estimation - INSEE - Ministerio de Fomento - Odyssee - STATEC - Statistics DK - Statistics FI

As we can see from the graph the building stock by type of dwellings differs significantly across the Europe. In the United Kingdom and Ireland, single-family dwellings are the dominant type above 80%, while in Spain and Estonia, multi-family dwellings represent more than 70% of all dwellings. If we look at the EU average, there is almost an equal share of both types of dwellings, with an average of 49% for multi-family dwellings.

A single-family or detached house is a house that is separated from its neighbors on all sides. This type of house has open space around it and it is exposed to the weather conditions and views from all directions. Additionally, it gives the possibility of more flexible floorplans, and the variation in size and design of the building and the surrounding spaces are limitless (Konstantinou, Façade Refurbishment Toolbox 2014).

Terraced or row houses are single-family houses built in a line, with their two walls to be shared, separated with a small cavity, or adjacent to each other. The entrances of the dwellings are located on the façade that it is shown from the street. Most of the time this type of houses is in cities where the space in the urban environment is limited. The row houses use the land efficiently and give the opportunity for higher densities while preserving more space for exterior interventions (Konstantinou, Façade Refurbishment Toolbox 2014). It is necessary to mention that with this type of houses we can achieve less use of materials and less heat losses because of the shared walls between the properties. On the other hand, the typical construction of this building type is based on repeatability to reduce design and construction costs with a result, whole neighborhoods have the same simple design because one contractor took over the whole construction.

Multi-family houses are buildings that contain more than one family with several housing units and referred to as apartments or flats. This kind of building can be perceived as terraced houses or detached in the case of row houses type, the entrance of the building is common for all dwellings at the ground floor level. This building type is suitable for cities where the land values are high and there is a need for more dwellings which subsequently creates a higher-density urban environment. A common form of multifamily houses is the apartment blocks. They existed since earlier years, but became very popular after the Second World War, when there was extreme housing shortage and the need for higher densities. As a result, the traditional building methods became the past, as developers searched for fast and economical and efficient construction methods to cover the demand.

4.3 Residential building Construction Characteristics

The European building stock consists of buildings from different countries with several climate variations, different traditions, materials, and construction methods. This situation leads to a very diverse sum of buildings that is undoubtedly very complicated to be analyzed as one case. This section is aiming to give an overview of the main building elements such as the main structure of the building and the façade in order to get more information about the European residential building stock and its characteristics. The construction types are most of the time directly connected with the construction techniques of each time period. Every time-section has a different cultural perspective and technology, a fact that influences a lot the goals that need to be achieved on each period. New materials and construction techniques helped to reduce the consumption of natural resources and labor costs.

In addition, architectural improvements and experimentations, alterations of aesthetic tradition and wealth, reaction on structural damages, health care and energy saving have led to changes in the building stock during time (Konstantinou, Façade Refurbishment Toolbox 2014). The table 3 illustrates the main reference points during the time and how they influenced the construction sector to be adapted in the demands of each era.

Table 6, source: (Konstantinou, Façade Refurbishment Toolbox 2014)

Time period	Benchmarks	Characteristics
The pre-industrial years before 1870	Historical buildings (1600) Vernacular architecture	Built on experiences Hardly any legal requirements Use of locally available materials Masonry load-bearing internal and external walls Buildings with tall, big rooms
The pre-modernism years 1870-1920	Industrial development (1870) Modern Movement	Rapid expansion of cities Growing industrialisation Standardisation of construction Technological achievements (steel construction, reinforced concrete)
The interwar years 1920-1949	End of World War I, the Political renewal, social and artistic reformations along with technological progress Modern Movement prevailed	Large, homogenous residential developments Community urban planning, open public areas, amenities, parks Apartments with good daylight and ventilation, strictly functional layout
The post-war years 1950-1975	The years after the World War II Reconstruction Urban planning based on modernism ideas	Non-traditional building systems High housing production Cheap and quick construction Functional, sunny airy houses Middle-rise (up to 4 floors) and high-rise residential buildings with generous distance from each other
The prosperous years 1975-1990	Economic growth Energy crisis in 1973	Higher quality of construction First awareness of more "energy efficient" buildings First building refurbishments in older, historical buildings
Recent constructions 1991-Today Note: Buildings of that period wouldn't normally be considered for refurbishment	Ecological and energy awareness (Kyoto Protocol) followed by national and international legislation Technological achievements in advanced material Renewable energy sources	Minimum thermal performance imposed by regulations (EPBD) Building performance certificated Incorporation of RES into buildings Passivhaus and zero-energy buildings

Every period has to overcome new challenges that happened for different reasons. This time we are facing an environmental crisis and the construction sector owes to overcome this obstacle. Renovation of existing buildings to reduce the energy demand is an issue of a paramount importance. Therefore, the understanding of the main structure and the building envelope will help in the process of defining the method of renovation with prefabricated façade systems.

Building structure types

As far as the building structure is concerned, three are the main structural types that can be categorized, loadbearing external walls, skeletal frame and box-frame structure (Konstantinou, Façade Refurbishment Toolbox 2014).

Loadbearing external walls have a double character, as the façade supports the weight the roof and the internal floors but also works as the barrier between the interior and the exterior climate. The walls are solid, constructed from monolithic or composite elements, perforated with opening for light and air. (Konstantinou, Façade Refurbishment Toolbox 2014)The method used firstly to solve the problem of the weakening of the fabric of the solid wall by the openings creation was to use horizontal beams and arches (Ulrich Knaack, Tillmann Klein, Marcel Bilow, Thomas Auer 2007).

In skeletal frame structure, the horizontal elements (beams) are supported by vertical elements the columns. This construction method can be also out of steel reinforced concrete, steel or timber beams and pillars. This type of construction allows the analysis of the wall in the load-bearing structure and the filling, which is then the element that determines the space. (Ulrich Knaack, Tillmann Klein, Marcel Bilow, Thomas Auer 2007). This type of structure gives the opportunity for big openings in the façade. Skeletal frame was used as the main methode in the post war years, due to high prices or shortage of steel (Giebeler 2009).

Loadbearing internal traverse walls, also became popular in the postwar years. Based on the possibility of simplified concrete construction, this method allowed the construction as fast as possible and was used in industrial and apartment buildings. (Macdonald 2003). The box-frame structural system allowed greater building depths and was therefore regarded as more economic. (Giebeler 2009)

Building envelop types

In order to answer the research question, many steps have to be done. One of the most important is to explore the variations of the building skin in Europe's existing building stock. This section is very important for this thesis because the building envelope consists of the most crucial elements of the building that influence the internal climate and the aesthetic of the building, a fact that a façade renovation approach has to include into its techniques and methods.

These elements are the roof, the exterior wall, the ground floor and the windows. A classification of traditional and non-traditional construction methods that refers to the building envelope has been made from Thaleia Konstantinou and it is shown in table 4. This table will contribute to identify the construction types in the case study buildings in chapter 7.

Table 7, Source: Konstantinou (2014)

	Construction type	Description	Structure	Windows	Roof	Period	Area	U-values (W/m ² K)
Traditional	Tunber Frame	Timber-frame structure with brick or wattle-and-daub filling	Loadbearing external walls	Single glazing Timber frames	Timber structure Clay roof tiles	< 1920	North-west, centre-east, south Europe	2
	Masonry walls	Masonry of solid brick or stone, 250-400mm				<1950		2-1,8
	Masonry walls 2	Two leaves of masonry with intervening air cavity				1920-1950		1,5
	Construction type	Description	Structure	Windows	Roof	Period	Area	U-values (W/m ² K)
Non-traditional	Cavity walls	air cavity and/or insulation. Lightweight masonry units, concrete walls, lime stone. Insulation thickness varies from 30-50mm to today's standards	Load-bearing external walls or traverse walls	Double glazing timber or aluminium frames	Reinforced concrete or timber structure	1950- today	North-west, centre-east, Europe. Usually facing bricks	1,1- 0,5
			In-situ reinforced concrete frame		Reinforced concrete slab with insulation	1975- today		0,6
	Lightweight concrete /perforated bricks	Lightweight masonry units (concrete or hollow bricks), often cladded	Load-bearing traverse walls, in-situ or pre-fab	Single or double glazing timber or aluminium frames	Reinforced concrete or timber structure	1950- 1975	North-west, centre-east, e.g. Germany, Denmark, France	1,4
			In-situ reinforced concrete frame			1950- today		South Europe
	Panel building	Prefabricated concrete panels, sometimes with insulation 50mm	In-situ reinforced concrete frame or prefab load-bearing	Single or double glazing timber or aluminium frames	Reinforced concrete or timber structure	1950- 1975	North-west, centre-east Europe, e.g. Germany, Poland, Denmark	1,1-0,9
	Lightweight façade	Sandwich panels consisting of asbestos cardboard/ plasterboard and insulation (40-70mm). Different cladding materials possible	Load-bearing traverse walls, in-situ or pre-fab					North-west, Europe, e.g. the Netherlands, Denmark
	Timber-frame brick cladding	Timber-frame with insulation infill, boxed in plasterboard, Brick veneer. Different cladding materials possible	Load-bearing timber frame wall		Timber structure, clay roof tiles	1950- today	North-west, centre-east Europe	0,8-0,5

The evolution of the construction method from the traditional methods to non-traditional ones is obvious as until the 1950s there is no use of insulation material at all and the only precaution against the thermal conductivity was the cavity between the two leaves of brick wall or the material properties. Other differences can be found in the table between the different areas.

For instance, the brick as a cladding material and the prefabricated concrete panels in the northern and central countries, a fact that in the southern European countries are not familiar with. The information from the table shows the different techniques that have been using during the years to construct the building envelope. All these characteristics will play an important role in the design process of the prefabricated façade system because most of these walls will be the existing surfaces that the adjustable façade system for renovation will be attached to.

CONCLUSIONS

This chapter describes the general situation of the building stock in Europe. This step was made in order to define the building type and the construction characteristics where the façade system will be applied. The type that has been selected for the application of the façade renovation system is the residential buildings.

More specifically, the building type that the façade system for renovation will be applied to is the apartment block building (multi-family house) as a detached or terraced house. The selection of this kind of building type was made due to its homogenous construction and the repetition in the building envelope a fact that will make the façade system for renovation easier to build and apply.

Additionally, in many European countries, residential buildings have been built with the exact same characteristics using prefabricated methods in order to reduce construction costs. This situation gives the opportunity to apply the renovation system in these particular buildings more than one time by following the same method to renovate more than one building.

Furthermore, the existing performance of the building defines the potential of improvements, the lower the performance is, the greater the room for improvement. With this as a given, the buildings that are in need of energy improvement and renovation will have a larger impact on their performance and have been built from 1920 to 1990, according to the data in the literature research.

To sum up, the requirements that the building has to include in order to apply the renovation system are:

- Poor energy performance
- Low to middle-rise
- As flat a facade as possible
- Load-bearing structure in good condition
- Repetitive façade elements with similar floors and openings
- Built, based on industrialized construction methods

The aforementioned typological properties of this building will give the opportunity in the final façade renovation system the potential to be mass-produced and industrialized, which is one of the main objectives of the final result.

5. Principles of Renovation

Given the task of refurbishing the existing residential buildings, there are some necessary steps that have to take into account in every case of a potential refurbishment. Therefore, this chapter sets off the principles of a renovation process related to energy performance of a building. The first section presents the main renovation strategies in order to renovate and increase the energy efficiency in buildings. The 5.2 section shows the basic sustainable principles and the main passive and active measures. In the final section describes the importance of modularity and adaptability in the production process of a product.

5.1 Energy approach

There is no doubt that in the environmental crisis that we live in, every step in the building construction process, either for new built or renovation of existing one, the protection of the environment factor has to be involved. As it is mentioned above building sector has one of the biggest percentages in greenhouse gas emissions, fact that needs to change. The way to tackle this challenge is by upgrading existing dwellings into passive and sustainable houses that use more renewable energy sources while providing better thermal conditions for the inhabitants. Defining an appropriate adjustable system for renovation that utilize a series of different techniques could be a solution to the problem. Modular component application for different climates and typologies and use of environmental elements such as the air and the sun can show the way to achieve better energy performance in existing building stock. The above criteria can be identifying as bioclimatic principles.

A concept that follows environmental principles and design is the “Trias Energetica”. This strategy is the most commonly used to ensure that sustainable measures are implemented efficiently. The bellow scheme illustrates three steps that rank the sustainable criteria for the building industry. The first step is to minimize the energy demand. The second step is to use energy from renewable sources as much as possible and thirdly if still more energy is needed fossil fuels should be used as efficient as possible (Konstantinou, Façade Refurbishment Toolbox 2014).

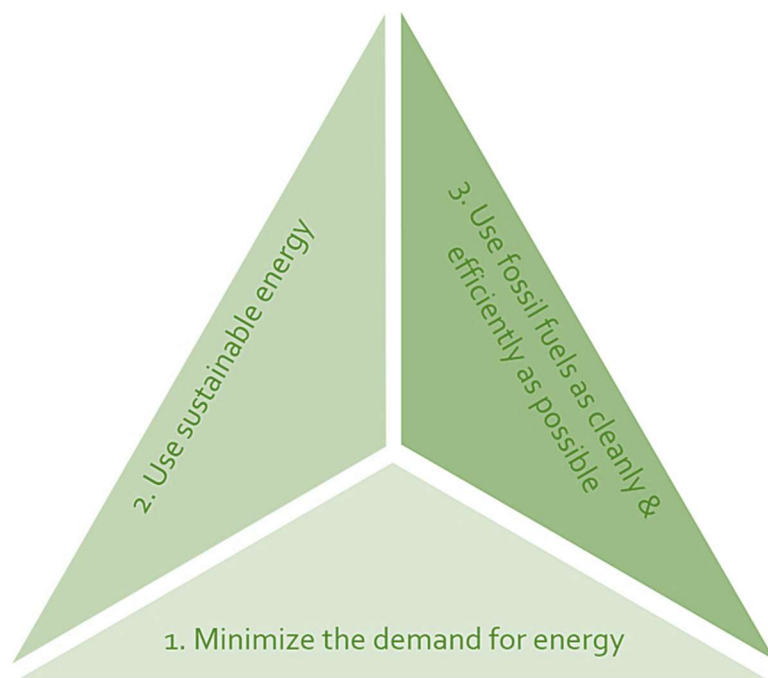

Figure 21, Trias Energetica

Trias Energetica concept includes two types of measures that have to be taken during a renovation of a dwelling, the passive and active. Passive is the principle where makes use of the design and the properties of the building envelope in order to keep the indoor climate in comfort levels. In addition, all the systems such as heating and cooling systems or solar power technologies belong to active measures and are used to fill the gap where the passive measures cannot achieve in the comfort of the occupants.

5.2 Passive and active measures

Passive design principles

The aim of the passive design is to reduce the energy demand of the building by exploiting the locale climate and environment elements, building characteristics such as building layout and materials. Passive principles can be classified into three basic functions. Heat protection, solar heat gain, and heat rejection.

Heat protection

The building envelope is the main barrier that should minimize the heat flow due to the temperature difference during the winter but also in summer. This happens because the warm air either from outside in the summer or from the inside in the winter has the tendency to balance the temperature difference by going from the warm to the cold environments through the materials of the building or through air gaps. Therefore, increasing the airtightness and thermal resistance of the building envelope and windows is the main strategy for heat protection.

Insulation

Materials with high thermal insulation value prevent the heat flow between two spaces with temperature difference. In most cases this kind of materials are used in opaque surfaces of buildings to improve thermal and sound insulation of the building. There are different kinds of insulation material in the market such as polystyrene and rock wool. (L. Adityaa, T.M.I. Mahliaa, B. Rismanchi, H.M. Nge, M.H. Hasane, H.S.C. Metselaare, Oki Muraza, H.B. Aditya 2017)

Insulated windows

Windows are very important elements of the façade as they create a visual connection with the exterior environment. Apart from that, windows are the main element that supply the interior with light and fresh air.

However, windows have a very poor thermal resistance in most cases. There are some techniques that can increase the insulation value of the windows. One technique is by increasing the amount of glass panes and subsequently the number of cavities the thermal insulation of the windows can be increased due to the increased volume of air. The use of less conductive gas between the panes can increase the insulation further.

Cold climate: Solar radiation admitted

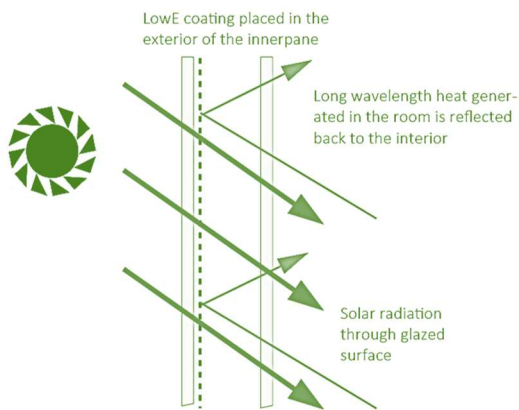

Hot climate: Part of solar radiation reflected

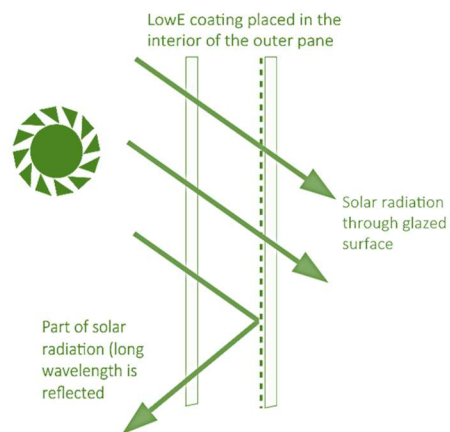

Figure 22, source: (Konstantinou Thaleia, Prieto Hoces Alejandro 2018)

Another method to increase the insulation value of the window is by applying low-emissivity coating on the glass panes. These coatings consist of a microscopically thin layer of metal oxide or semiconductor film and are applied on the faces between the panes, facing the cavity. The frame of the window plays important role also. Window frames come in a wide variety of materials. When a material has high thermal conductivity it is important to incorporate thermal breaks to avoid thermal bridges.

Infiltration

The phenomenon of infiltration is when the air travels through leaks and cracks, but also through pipes and cables of the building or other small openings of the building envelope. This phenomenon is one of the most leading causes of heat energy loss.

Infiltration can be minimized by implementing air-tightness throughout the design and construction phases. Sealants such as expanded foam, tapes and fillers can be utilized to prevent uncontrolled air and water flow through the construction (Konstantinou Thaleia, Prieto Hoces Alejandro 2018).

Solar control

Solar radiation can have a lot of benefits during winter however during the summer season should be avoided to enter the interior spaces due to overheating. Shading systems can vary significantly in design, size, and placement, ranging from simple Venetian blinds to more advanced and complicated systems, which ultimately determine the entire building architecture. Different kinds of shading systems can be applied on the building depends on the desired performance and aesthetic criteria. Nevertheless, every choice will come with advantages and drawbacks. For example, internal shading is not as efficient as the external one but is more cost effective and needs less maintenance.

The position of the shading systems is completely related with the orientation of the surface that needs to be shaded. For example, horizontal louvers are used for the south because they block the high angle sun path in the summer, while they let solar heating during the winter period by allowing lower angle sun rays to penetrate the room. On east and west building surfaces, movable vertical louvers are preferable because the sun strikes at low altitudes (Konstantinou Thaleia, Prieto Hoces Alejandro 2018).

Heat gain from the sun

During the cold months of the year passive solar heating is essential when lot of energy is required to reach thermal comfort in the interior of buildings. This can be achieved through the transparent elements of the façade that can collect, store and distribute solar energy. The most suitable orientation is the south for this purpose. However during the hot period when the heating effect is not needed the transparent parts should be protected with shading (Konstantinou Thaleia, Prieto Hoces Alejandro 2018).

Direct solar gain

The property of the glazed surfaces of the building to allow the solar radiation to heat the interior space is very beneficial for heating the interior. This effect is based on the principle that glass is permeable for short-wave radiation (ultraviolet radiation) from the sun but impermeable for the long-wave heat radiation, which is emitted by the materials. Many parameters determine the effectiveness of the direct solar heating such as the interior layout and the area of the transparent surface.

Solar buffer space

Solar buffer space is intermediate space between the interior and the exterior. This space can encircle the heat from the solar irradiation. The temperature in this zone is higher from the exterior and as a result the transmission heat loss of the indoor environment is reduced. Double façade can also work as a buffer space as there is an exterior surface that creates an intermediate space between the exterior wall of the building and the outdoor environment.

Indirect heat gain

Indirect solar heat gain occurs when a component has high thermal mass. This phenomenon can be achieved by using transparent outer layer and a heat-absorbing element between the incident solar radiation and the space that needs to be heated. That way the solar energy transmitted through the transparent surface and absorbed by the outer surface of the wall. Lastly the heat conducted through the wall until reaching the internal side of the wall few hours later. Another method to transmit the heat from the heat-absorbing element through the air. A very typical use of this technology is known as Tromp wall and the attached sun spaces.

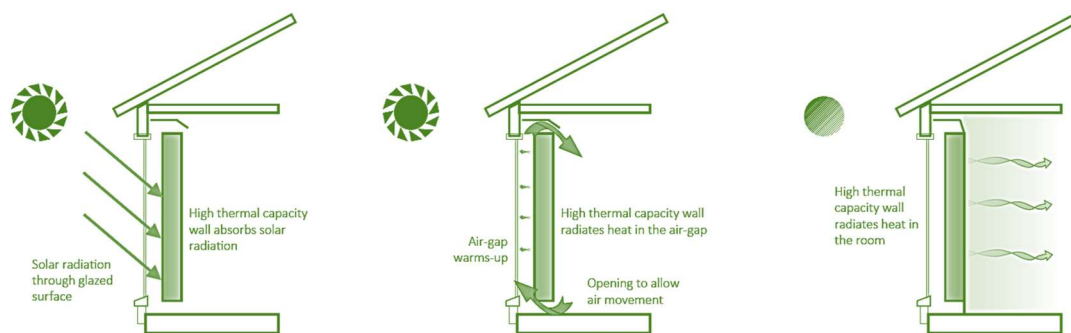

Figure 23, Source: (Konstantinou Thaleia, Prieto Hoces Alejandro 2018)

Heat rejection

As it is stated previously the use of shading systems can minimize indoor space overheating and subsequently reduce the energy demands for cooling. Nevertheless, over heating can occur from internal heat gains and solar heat gains that cannot be avoided even when optimized shading methods are used.

Heat rejection strategies are used to remove the indoor heat and release it into the exterior heat sink, such as air, water or ground. This can be accomplished with passive strategies without using energy. However with some additional technical equipment such as fans and pumps that called hybrid or low-exergy heat rejection systems better performance can be achieved (Doreen E. Kalz, Jens Pfafferott 2014).

Ventilation

The most common strategy to for heat dissipation is ventilation. There are two main methods that are based on comfort ventilation and nocturnal ventilation (Konstantinou Thaleia, Prieto Hoces Alejandro 2018). Comfort ventilation is utilized when the occupants finds it necessary, improving the occupants perceived comfort. Nocturnal ventilation is used during the night by removing the heat to cool down the building for the next day. In addition, three ventilation strategies can be distinguished based on spatial orientation: Single-sided ventilation, cross ventilation and stack ventilation. Single-sided

ventilation will be applicable to every situation, whereas cross ventilation and stack ventilation are dependent on the configuration of the building.

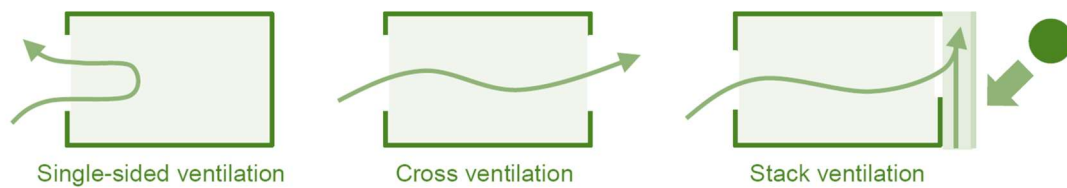

Figure 24, Source: (Konstantinou Thaleia, Prieto Hoces Alejandro 2018)

Active measures

Passive measures alone do not ensure the elimination of energy demand in all seasons especially in central European countries where heating is the main reason of energy consumption. Passive design measures aim to minimize the heating demand. However active measures are necessary to produce and distribute the energy needed for heating, cooling, ventilation, DHW, lighting and appliances.

Electricity

Equipment and electrical appliances consume 11% of the total energy. Even though, in a comparison with space and water heating is much less, it should be considered in an energy reduction renovation as well, as it can contribute to the energy performance of a building.

Daylight

Artificial lighting consists of 10% of the total energy electricity consumption in dwellings. Day light has to be the main factor of interior lighting in order to reduce the need of artificial light according to the passive design standards. Exploiting the daylight properly can reduce the energy demand in dwellings.

Electricity generation (RES)

Generate electricity from renewable energy resources can reduce drastically the energy demand in buildings and can replace a big percentage of the energy produced through fossil fuels. Renewable sources are solar radiation, wind and water movement. The most common technology the uses renewable sources to produce energy in building scale is photovoltaic panels.

The efficiency of the PVs is determined by the orientation and the angle of the panels surface. A very important factor that contributes majorly to this

system is the climate, as the cloud coverage plays important role in the solar transmittance.

5.3 Renovation strategies

At the beginning of every renovation project a proper strategy has to be defined. There is a wide variety of functional and energy efficiency challenges that the building industry has to solve. The renovation strategies can be divided in five main methods: Replace, add-in, wrap-it, add-on and cover-it (Konstantinou, Façade Refurbishment Toolbox 2014). Although a combination of two or more strategies can be applied at the same project when it is necessary.

Replace

One of the most common methods of refurbishment is by replacing the existing façade. The original façade is completely removed and a new façade that has better energy performance is applied. The replacement can happen also in specific elements that are insufficient. This strategy can be applied in every kind of façade.

Add-in

This method is generally applied when the existing façade has to be preserved due to for instance the building's monumental value. With this method the interior surfaces are covered with insulation. However, the extra thickness of the insulation reduces the total area of the interior space. This strategy is often accompanied with the replacement or by adding a second glazing surface on the windows, as they are commonly outdated too.

Wrap-it

This method uses a second layer around in the external surface of the building. This second layer can incorporate insulation, cladding of the balconies or second façade. The main advantage is that it can solve thermal bridging with increasing the thermal resistance of the envelope. Another advantage is that it is possible if the main structure can support extra weight, to create extra functional space. This strategy creates a new opportunity to not only enhance the building energy efficiency but also interfere architecturally and aesthetically.

Add-on

The add-on strategy consists of a wide variety of upgrades that can be used. From creating new balconies to a completely new structure as an extension of the existing. A common example of an add-on is a solar buffer space that can help passively to keep the indoor climate in comfort levels.

Cover-it

This strategy is mostly used in order to create internal courtyards and atriums in buildings. It is common when covering these spaces to use transparent surfaces in order to increase heat gains while at the same time allow the direct sunlight to reach the interior when it is necessary.

5.4 Modularity and adaptability

The terms modularity and adaptability are presented in this section of the literature with the aim to incorporate these principles in the façade system that will answer the research question. These principles have been chosen as the modularity is one of the factors that can help to solve common problems for large numbers of projects and adaptability is the key factor that is needed in order to achieve same system application in different situations.

The goal of this thesis is to create a façade system for renovation that can be adjusted in most of the residential building types in Europe and in the different climates while increasing energy performance. The European goal is to renovate around six million buildings per year until 2050. It is not possible to achieve this by following the existing methods of a typical renovation as each building renovation is very time-consuming process. Industrialization of the process and mass customization will be the solution for a faster process, lower prices and better quality. The main idea of the mass customization approach is design products that can be partially customized while at the same time trying to meet the standards of efficiency, cost, and quality of mass production (Bart MacCarthy, Philip G. Brabazon, Johanna Bramham 2003).

The product modularity (or modular architecture) is one of the key factors of mass customization strategies. Consists of the use of a limited set of modules to create several product variants (J. K. Gershenson, G. J. Prasad, Y. Zhang 2010). The use of modules to build a wide range of dwellings has been turns out as one of the necessary methods to improve the energy performance of the building industry (Cecília G. da Rocha, Carlos T. Formoso, Patrícia Tzortzopoulos 2015)

There are many expressions to describe the term “modular” in these section some of them are presented in order to define the main characteristics and meanings of the term.

Modules

Marshall describes modules as the ones who have the following characteristics:

- They are co-operative subsystems that form products, manufacturing systems, and so on.
- Functional interactions occur within and not between the modules
- They have one or more, well-defined functions that can be tested in isolation from the system
- They are independent and self-contained, and can be combined and configured with other modules to achieve overall function. (MARSHALL 1998)

Modularity

Modularity is a relative property. Products can have a higher or lower degree of modularity. A product with a higher degree of modularity either contains a

larger percentage of components that are modular, or contains components that are, on average, more modular. (K. Ulrich 1991)

Modularity is a 'strategy to organize complex products and processes efficiently. A modular system consists of series of modules that are designed independently but 'function as an integrated whole'. In addition modularity can be achieved by defining visible design principles and hidden design parameters' (D. W. HE, A. KUSIAK 1996)

Modular product

Modular product is defined as 'a function-oriented design that can be integrated into different systems for the same functional purpose without (or with minor) modifications'. Modular design can be applied as a method to increase the robust performance of a product. (Tzyy-Shuh Chang, Allen C. Ward 1995)

Modular design

Modular design gives the opportunity to design tasks for parallel development. To achieve that the overall design task has to be divided into smaller tasks and the interface between them should be properly defined. The design can be reused with minor changes if product modularity is applied. This reduces time and the effort needed to upgrade an existing product (Sosale 1997)

The term adaptability in this case is to describe the property of a system to adjust in different conditions

Adaptability

Adaptability in construction is possible if the whole system is based on the combination of various components and allows for small changes that have been determined during the design process. This can be implemented during system manufacturing according to demand and the incorporation of components that perform. (Capeluto 2019)

State of the Art renovation systems

In this stage of the thesis, three renovation systems are presented in order to analyze and compare the advantages and disadvantages of the different approaches. The aim of this process is to collect and utilize the necessary properties and techniques that will help to form the requirements for the design of the appropriate system that will answer the research question. In addition, the analysis will contribute to define the difficulties and the obstacles that need to overcome.

5.5. MORE-CONNECT project

The approach

The MORE-CONNECT project offers an innovative retrofitting process by applying prefabricated multifunctional renovation elements which could reduce not only costs, but also renovation time and disturbance for occupants and, at the same time, enhance quality and performances, both in terms of energy efficiency and indoor climate.

This method is based on using pre-fab modular elements for façade and roof and building services. These elements can be combined, and configured by the end-user, based on his specific needs. The use of pre-fab elements allows to build a mass production process which implies a reduced price for end users.

There is a set of modular elements for façades and roofs, using a decision making tree, which helps to determine the dimensions and shapes of wall modules and location of connections for the technologies that needs to integrated on the building.

The use of prefab multifunctional elements contains several components such as ducts, ventilation grilles and connectors which could form thermal bridges and cause a local decrease in performance, it is necessary to apply thermal insulation with different forms such as aerogels etc.

Demonstration of the MORE-CONNECT

In order to understand the possibilities of this prefab system, two different renovation strategies will be presented in this part. One with the **replace** approach in the Netherlands and one with the **wrap-it** approach in Estonia.

The Replace approach

The Netherlands: 4 multifamily buildings, Arnhem

The deep renovation aims to increase significantly the energy efficiency of the building envelope. The building envelope is replaced by prefabricated elements and micro energy generation technologies are installed such as heat pumps and photovoltaics.

The type of the building is a multi-family building with a repetitive identity which makes it very suitable for an industrialized renovation approach.

The general strategy to renovate this building is by removing the whole external cavity wall and replace it with new prefabricated wall elements with high level of airtightness and insulation. These elements are incorporate ventilation ducts for ventilation of the air since insulation and airtightness have been achieved.

Furthermore, Hot water for household use and for heating is generated using a water/water heat pump. Electricity is generated by PV panels. Around 28 panels generate enough kWh over year to supply all electricity needs.

Technical renovation concept

- Removing front and back facade (inner and outer layer of the cavity wall) and installing prefabricated façade modules front and back facade (new aesthetic façade design)
- Adding insulation and new finishing (brick-like tiles) to left and right facing facades
- Installing new windows with triple glazing
- Installing a new (mechanical) ventilation system with heat recovery (efficiency >74%)

After the design and engineering of the façade the execution of the project include several steps.

Firstly, the balconies protruding from outside the façade were removed while the remaining part of the balconies were added to the floor area of the apartments. At the same time by removing the balconies the thermal bridging is eliminating. This happened in order to create a flat façade surface for easier construction and installation of the prefabricated façade modules. Secondly, the necessary façade elements are removed. Next, the ground floor level was insulated with Expanded polystyrene (EPS) blocks and lastly the prefab modules were installed. The prefab modules consist of structural wooden frameworks and contain glass wool insulation (25 cm). The triple glazed windows with wooden frames were factory mounted in the prefab facade elements. The finishing of the elements consists of brick slips glued on the prefab modules (off-site). As far as the roof is concerned, an on-site

system was applied by adding a layer of insulation on top of the existing roof. Replacement of HVAC system and boiler was also a part of the renovation.



Figure 25, Before (left) and after (right) the renovation source: (More-Connect 2019)

In this pilot project, there were not many challenges compare with the next project that will be analyzed, as the whole process was similar to the construction of a new building with a prefabricated façade. Some of the minor problems that had to solve were:

- problems with the sagging of thermal insulation in the cavities of the façade elements
- Integration of ventilation ducts was difficult in some cases.

According to the More-connect report (More-Connect, 2019)

The production process needs to be further industrialized and automate the production of the façade elements. This time panels are moved from position A to B and during each step building components are added by craftsman until the façade element is fully produced and ready for transport to the construction site.

The Wrap-it approach

The building type that has been chosen is a typical multi-story apartment building made of big prefabricated concrete panels in Estonia in Tallinn University of Technology and constructed during 1986. The design service life of these buildings was 50 years, which is almost over. In addition, there are several topical problems, such as serious thermal bridges, mold growth at the external intersections of roof-wall, high energy consumption, insufficient ventilation, overheating during winter, unsatisfactory thermal comfort.

The general strategy

The strategy was to install the prefabricated modular panels onto the existing façade surface and roof and keep the load bearing structures. As in the previous application of the More-Connect project in the Netherlands the existing balconies covered and more space given to the total living area. In

addition, the walls in the basement were insulated on site with thermal insulation.



Figure 26. Installation of the module panels on the walls source: (More-Connect 2019)

Technical renovation concept

The unevenness of the existing external surfaces and the exact positions of the windows had to be accurate imprinted in order to create the façade elements that will incorporate the new windows and all the necessary features that will contribute to the better energy efficiency of the building. To do that a 3D laser scanner was used for the envelope before the design. The modules were hanged onto the existing wall from designed connectors, allowing adjustment of the modules in all three directions. To fill the unevenness and roughness of the existing surface 10-50 mm light mineral wool was added as a filling layer in the inner side of the modular element.



Figure 27. Before (left) and after (right) the renovation source: (More-Connect 2019)

- Modular element thickness was 340-380 mm
- The designed thermal transmittance of the external wall is $U=0.11 \text{ W}/(\text{m}^2\cdot\text{K})$

- airtightness of the entire building envelope is $q_{50} < 2 \text{ m}^3/(\text{h}\cdot\text{m}^2)$
- To prevent thermal bridges and minimize the impact of air leakages, smart connectors and innovative fixings, as well as sealants and polyurethane (PUR) foam have been used at critical joints.

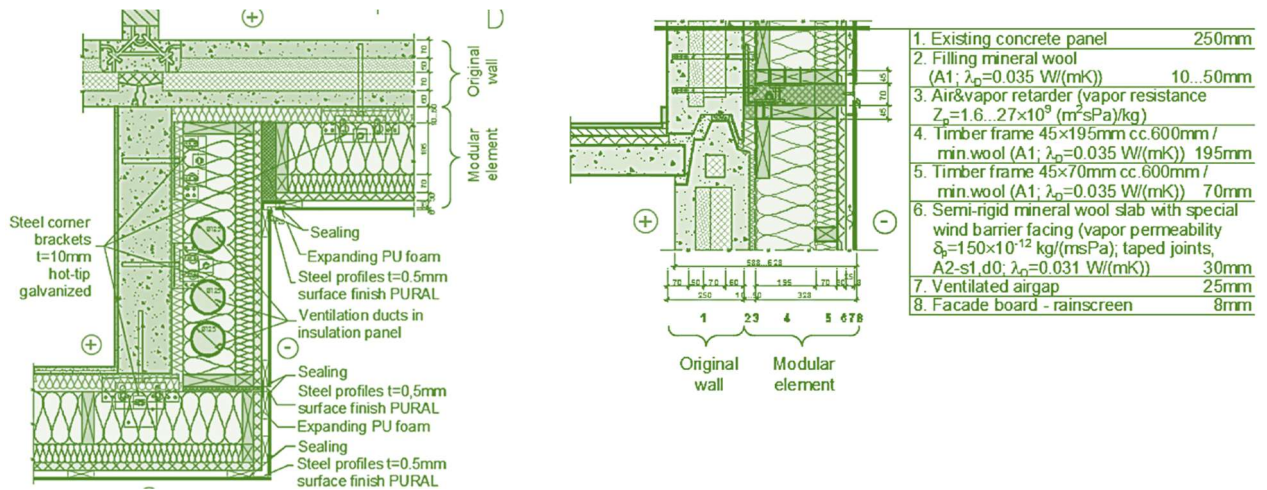

Figure 28, Design of wall insulation modules Source: (More-Connect 2019)

In this pilot project there were more challenges to overcome as the renovation strategy had different approach and more adjustments to be made. According to the report one of the challenges as far as the installation of the facade modules is concerned was the metallic brackets. The attachment of the new elements was slower than expected. The wall connection design with adjustable brackets proved to be possible but there were difficulties due to the heavy wall pieces into many support connectors at the same time as the elements bent during lift due to their own weight. These issues could be avoided with different way of lifting, better tuning of brackets design, smaller and/or stiffer wall modular elements. Another big challenge was the insulation method that has been followed for the horizontal external wall joints as the depth was up to 380 mm.



Figure 29, Insulation process with EPS foam after the installation of the façade elements Source: (More-Connect 2019)

5.6 The BRESAER system

BRESAER is a retrofit system that provides adaptability through combination of passive strategies and intelligence features, which can be used in different climates and diverse building types.

The main characteristics of the system are:

- **Structural metallic profiles** that ensure a lightweight standardized system which is easy to assemble and able to support all the different elements of the envelope. The elements are fixed to the aluminum profiles in a standardized way in order to be installed and maintained easily.
- **Multifunctional and multilayer insulation panels** made of High Performance Fiber Reinforced Concrete that can be used for building envelope applications. These panels provide insulating capacity, lightness and ease installation. They can be combined with several finishes for different results according to the users' preferences
- **Solar thermal air envelope** provides indoor heating, ventilation and thermal insulation. The preheated air is delivered to an air handling unit in order to be used for indoor heating and cooling.
- **Multifunctional lightweight ventilated façade modules** are polymer concrete modules that leave a ventilated gap between the building's envelope and the insulation. They are very efficient in eliminating the thermal bridges and condensation problems. The modules can be combined with several finishes: integrated PV films, thermo-reflective and self-cleaning coating.
- **Dynamic windows, automated windows.** Dynamic windows with automated and controlled air-tightness and insulated solar blinds achieve high energy performance and occupants' visual comfort: solar blinds automatically adjust to the position of the sun and can be combined with several finishes such as a thermo-reflective coating
- **Thermo-reflective, self-cleaning coating plus PV film** covers the envelope components. Where the coating is not applied and the orientation is suitable, a PV film can be added for electricity generation.

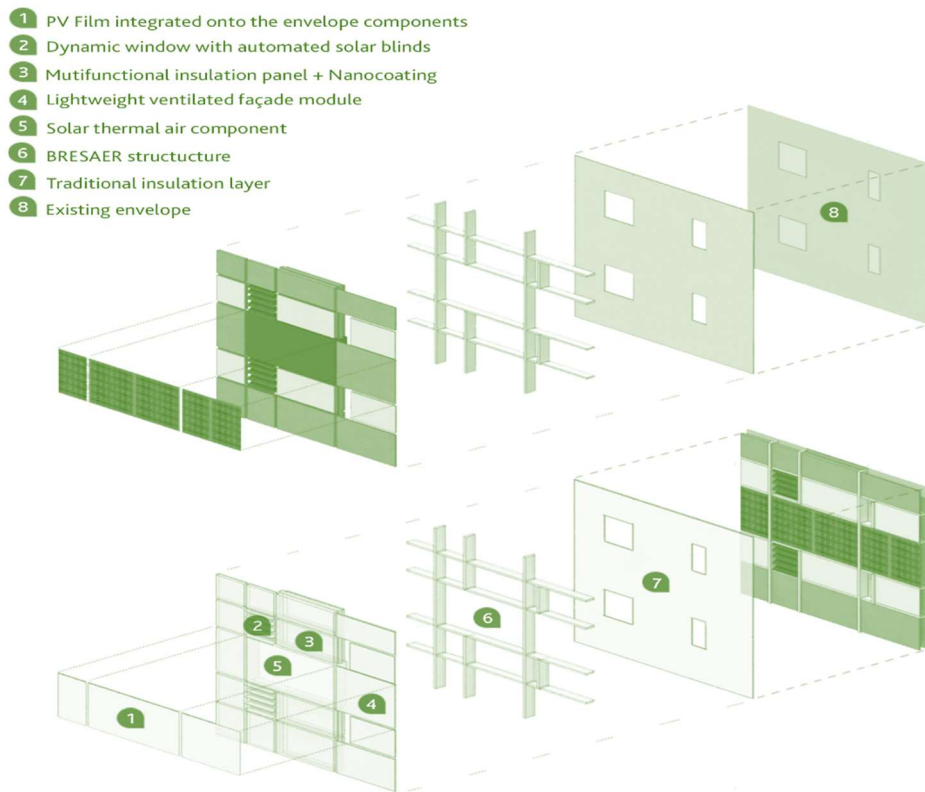

Figure 30, Schematic representation of the BRESAER system for facades. Source: www.bresaer.eu.

This project focuses in many aspects that can contribute to achieve better energy performance through a series of components that are incorporated in a standardized system. Unfortunately, there are not examples of the application of this system in real situations as in the previous section to see the advantages and the limitations. However, the principles of this system shows a different perspective as it aims in more industrial way of production process with standardized components and structure system.

5.7 2NDSkin Refurbishment Project

The 2ndSkin design principle aims to reach zero-energy dwellings by preventing the use of energy, then use sustainable energy sources as widely as possible and, finally and use of fossil energy sources if it is completely necessary.

The concept combines the building envelope enchantment, the use of efficient building systems and the sustainable energy generation. The improvement of performance of the building need to be upgraded with the minimum disturbance to the occupants.

For this project a reference building type was determined, which is considered the most common type in the area of investigation while having typical characteristics found in the building stock. The reference building, is a mid-rise apartment block with central staircase with access in the front facade, leading to two apartments per floor. Its construction characteristics are concrete wall and brick cladding, non-insulated cavity, reinforced concrete slabs, that continuous to the balconies, and large windows.

The goal was to meet the requirement of zero-energy consumption, the renovation solution consists of three basic elements:

- Increase the thermal resistance of the building envelope, including walls, windows and roof
- installing heat recovery ventilation, to reduce energy demand for heating while providing adequate indoor air quality (IAQ),
- use of photovoltaic (PV) panels to generate energy

More specifically, the steps for the renovation process are:

- Prefabricated, sandwich panels, integrated new windows and services pipes, are attached to a substructure that consists of wooden posts connected to external facade of the existing structure through steel U profile.
- PV panels are installed on the roof, while installations to improve ventilation are also integrated in the rooftop.
- The ventilation pipes are integrated in an insulation board, attached to the sandwich panel that covers the opaque part of the existing façade. In order to minimize the connections between the pipes the panel was installed as one piece.

Finally, PV panels are also integrated in the skin in order to reach the zero energy targets.

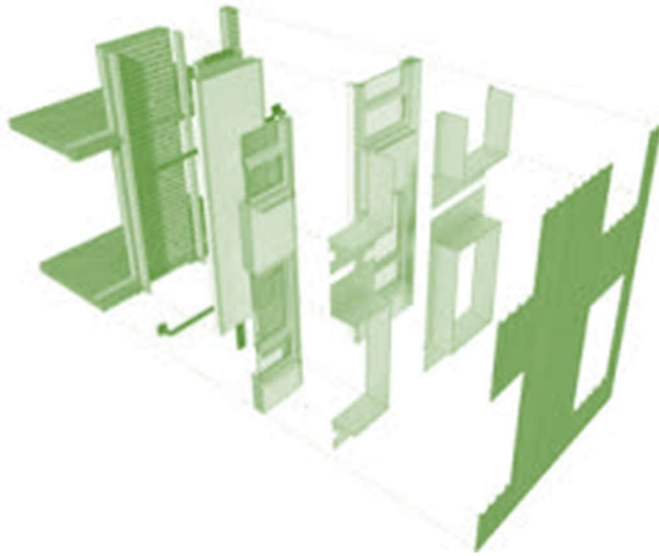

Figure 31, The sequence of the prefabricated elements installation (from the left to the right). Source: (Konstantinou, Guerra Santin, et al. 2017)

5.8 Evaluation of the systems

In this section a comparison of the three renovation approaches from the section 5.5, 5.6 and 5.7 is presented with the aim to identify the key elements and the limitations of each method.

Firstly, a distinction has to be made among the three approaches to define better the different approaches. The MORE-CONNECT can be characterized as a method of renovation that can follow different design strategies (Replace, Wrap-it etc.). On the other hand, the BRESAER approach is more about a renovation system that uses one main system with a variety of different energy components. Lastly, in the 2nd Skin Refurbishment Project incorporates some of the principles of the More-Connect project such as the wooden substructure and the integrated windows in the floor-height panels combined with some of the BRESAER's active measures such as the PV panels.

Nevertheless, the comparison is possible to be done by comparing the overall approach of the renovation. In the three tables are presented the main characteristics of each method.

MORE-CONNECT	Main characteristics	key points	limitations
Building type selection	Buildings with basic architecture characteristic and repetitive floors with as few differences as possible.	Easy to apply the same techniques in more than one building with small adjustments.	Limited choice of building type as it can be applied only to buildings with simple architectural structure.
Renovation Strategy	Wrap-it, Replace, Add on	Intervention from the exterior of the building, leads to less inconvenience for the occupants. (not for the replace)	Difficult to apply the prefab modules in the connections due to the unbalanced weight. Very precise measuring of the existing envelope.
Energy Reduction Measures	Mostly passive with the use of insulation. When active measures are applied are heat pumps and PV panels	Efficient in cold climates because of the insulation and the windows replacement.	Inefficient in warm climates due to the lack of sun protection methods.
System structure	Wooden prefab façade modules, produced off-site based on techniques that are applied also in new builds.	Sustainable material due to the low embodied energy. Easy to handle without special tools.	Wood is a heavy material and large cross sections are needed to support built-in windows, ducts, etc.

Table 8, More-Connect project evaluation

BRESAER	Main characteristics	key points	limitations
Building type selection	Can be used in different diverse building types.	Application in most of the building types means a greater impact on the existing building stock	Not enough evidence to prove the applicability of the system (not real application)
Renovation Strategy	Wrap-it, Add on	Intervention only from the exterior of the building, leads to less disturbance for the occupants.	On-site installation of the system, resulting in time consuming, which increases costs.
Energy Reduction Measures	Incorporates most of the necessary techniques to reduce the energy consumption of a building. Focuses on new technologies.	Effective in all climates, as it has components for every weather case.	The ability to integrate multiple techniques makes system management difficult and requires additional management tools for monitoring.
System structure	Lightweight standardized system which is configurable, easy to assemble and able to support all the different envelope components.	Easy installation maintenance and replacement of the system due to standardization.	Limited literature to access as the project is still in progress.

Table 9, Breasaer project evaluation

2ND SKIN	Main characteristics	key points	limitations
Building type selection	mid-rise buildings with typical features (based on the current application example)	Has the potential to use these techniques in more buildings, with some adjustments.	Flatten the façade surface by demolishing protruding balconies
Renovation Strategy	Wrap-it, Replace	Intervention only from the exterior of the building, leads to less disturbance for the occupants.	Encounter the renovation of the building as a project, making it more difficult to apply the same approach to other buildings.
Energy Reduction Measures	Incorporates the most common techniques for a cold climate. (insulation, heat recovery ventilation, PV panels)	Efficient in cold climates as it is focused on the Dutch climate.	Inefficient in warm climates due to the lack of sun protection methods.
System structure	Prefabricated, floor height, sandwich panels, featuring new windows and integrated services pipes, are attached to a substructure that consists of wooden posts connected to external existing façade.	The installment of all the ventilation pipes in one sandwich panel with insulation helps to minimize the connections between the pipes on site.	Each element has its own support system, the approach is closer to standard renovations.

Table 10, 2ND SKIN evaluation

According to the data from the above tables, some critical steps stand out:

- All renovations refer to buildings with simple architectural elements that are repeated in all floors.
- The Wrap-it renovation strategy is the fastest and most efficient method with the least disturbance for the occupants.
- The most used energy reduction measures are insulation, new windows, PVs and heat recovery ventilation.
- Wooden posts are the main elements that are used to apply the new systems on the existing building envelope.

The results of the research in this chapter will help shape some of the factors that will be integrated into the new system.

Conclusions

This chapter describes and analyzed the necessary sustainable design principles through the “Trias Energetica. The renovation strategies are also a very important part of this chapter as it illustrates the different approaches and the potentials of each method. Additionally, the passive and active measures are presented with the aim to incorporate the most suitable ones in the final design.

The principles of modular design and the adaptability are described as a factor that will help to design a mass-produced system with adaptable structural system and modular components.

Furthermore, a series of different approaches based on the state-of-the-art renovation practices, are presented in the last part of the chapter with the aim to define the key points and the limitations of each strategy in order to use them in the design.

6. Design Specifications

A design strategy has to be formulated as a guide for the design, based on the literature study and the State-of-the-Art renovation projects. The design methodology consists of requirements, principles, challenges, and tools that can be consulted in order to formulate an appropriate design concept.

In section 6.1 of this chapter, the design strategy will be presented through the steps of the literature review in order to formulate the façade system for a renovation that satisfies the thesis goal. Section 6.2 lists the principles and tools that will create the facade renovation system.

Finally, in section 6.3 the generic design of the system is developed.

6.1 Design Strategy

This section shows the design and the energy related information that are collected from the literature and contribute to find the common principles that will shape the final design. The design and the results from each chapter of the literature will be explained with the aim to create a list of requirements that have to be included in the design.

Firstly, in chapter 3 the climate in Europe is analyzed and two different climate zones are selected for further elaboration. The data contribute to the design process can be found in the last part of the chapter, where the basic design principles for warm and cold climates are presented. The result that has been concluded from this chapter determines the first part of the design that needs to be incorporated into the renovation system. This part is related to the energy reduction elements of a building and consists of some specific functions. These elements are insulation, sun-shading, natural and mechanical ventilation, high-efficiency glazing, airtightness, and building integrated PV panels. As far as the functions are concerned, these are the reduction of heat transmission, the improvement of air quality, the protection from solar irradiation, and the power generation from the sun.

From chapter 4, it was concluded that the building type where the façade system for renovation will be applied is the apartment block building. Additionally, in order to decrease the complexity of the production of the system and make the application of the façade renovation system easier, the type of buildings that the system will be applied are the buildings where the envelope has the same floor design, repetitive elements, and openings (windows, doors, etc.) and follows an industrialized construction approach.

In chapter 5 the main renovation strategies, the Passive and Active principles and the best renovation practices are showed. The data from this chapter will contribute to define the design guidelines that will shape the final principles. At the same time, due to the analysis of some of the best renovation practices, we were given the opportunity to know the possible challenges that the facade system will face due to the reported results from the pilot projects implemented in real conditions, a fact that will contribute to the

adoption of some renovation practices or in the improvement of certain elements which could be improved to achieve even better results.

To sum up, the final design will be formed based on three parameters, the climate, the building type, and the best renovation practices. In the next section of this chapter, these three perspectives will be elaborated on and will show how they affect the creation of the system.

6.2 Generic Design Principles and tools

The design principles will be presented based on the literature review and will be explained for each part of the façade system separately. The design consists of three main functions.

The first is the dimensional and structural adaptability due to the different lengths and widths that the façade modules of the system can have, based on the existing building envelope characteristics.

The second function concerns the ability of the system to adapt to different climates due to a range of energy reduction elements that can be selected according to the energy reduction goal to be achieved. A very important feature of these energy elements that makes them compatible with the structural part of the system is that most of them can be adapted to different dimensions just as the structural part.

The third function that makes the renovation system adjustable is the possibility of applying it to different construction types of existing buildings.

STRUCTURAL FRAME PRINCIPLES

The structural part of the modular façade system is the base where all the individual properties of the system come together. The production of the façade renovation system is based on prefabrication methods to achieve better product quality and easier application. The structure is made out of timber and it is constructed in such a way to incorporate the appropriate elements for each case scenario. The timber selected as the appropriate material due to the low embodied energy, in comparison with other materials that can be used for structural stability. The use of wood as a material contributes also to the better thermal performance of the system due to the low thermal transmittance. The ease in the process of manufacturing timber structures contributes to a more efficient way in the case of mass production which is in line with the basic requirements of the system.

Due to the fact that the new system has to adjust to existing surfaces with different dimensions, the property of timber being cut relatively easily in different lengths and widths, makes wood one of the best choices for the system. A fact that is confirmed through the use of timber in most of the pilot projects of renovation with similar renovation techniques. The nature of wood that can be screwed at any point without extra preparation increases the simplicity during the assembly process of the system.

The design process of the frame to the desired dimensions starts by imprinting the existing façade of the building and define the opaque and transparent areas. The next step is to create a grid, based on the existing building envelope and divide each floor into smaller pieces. These pieces will be the modules of the system. There are some principles that define the dimensions of the grid and the size of the modules.

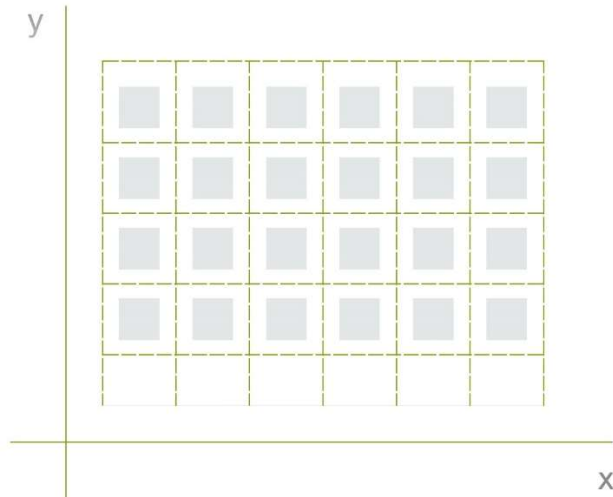

Figure 32, abstract demonstration of the grid application in a building façade.

The dimensions of the grid can vary. In the vertical (Y) axis, the height range of the floor is the main parameter that determines the height of the modules on every floor. In the selected type of buildings that the facade renovation system is referring to, the height can vary between 2.6-3 meters. As far as the horizontal axis is concerned, there are different parameters that determine the horizontal dimensions of the modules. These parameters are the need for easy transportation and easier installation in the existing building with the use of a crane. Hence the horizontal length of the modules cannot be very big. To define the maximum length of the modules the knowledge from the state-of-the-art renovation projects has taken into account. The six meters are determined as the maximum length that a module can have on the horizontal axis.

Regarding the thickness of the timber structure of the system, is determined based on the structural stability that is needed in order to be able for the module to integrate the necessary elements. More specifically, the thickness of the modules that have integrated windows cannot be less than 8 cm as the minimum thickness of the window frames is 8cm. Another factor that can define the thickness of the structural part of the modules is the insulation thickness, when the insulation increases the total thickness of the module increases. Nevertheless, the maximum thickness of the modules can be 18cm. This restriction on the insulation thickness comes from the fact that the effect of the insulation due to its thickness does not change drastically after a certain thickness. However, due to the fact that the thickness of the insulation

determines the total thickness of the modules, the maximum thickness was decided to be 18 cm in order to keep the total weight of the modules at relatively low levels.

As far as the dimensions of the cross-sections of the timber supports of the modules and the spacing between them are determined according to the total thickness and the span that they cover.

The cross-sections range from 8-18 cm for the large side of the beams as they are defined by the overall thickness of the beams and for the small size of the beams, it ranges from 4-6 cm.

The length between the timber beams of the modules ranges between 20-60 cm in order to have a stiff structure to support the necessary elements and have a minimum area of around 20cm of insulation on each side depending on the size of the cross-section of the beams. The 60cm is determined as the maximum length between the beams due to the dimensions of the PV panels but also in order to have a stiff structural skeleton for the modules to avoid bending.

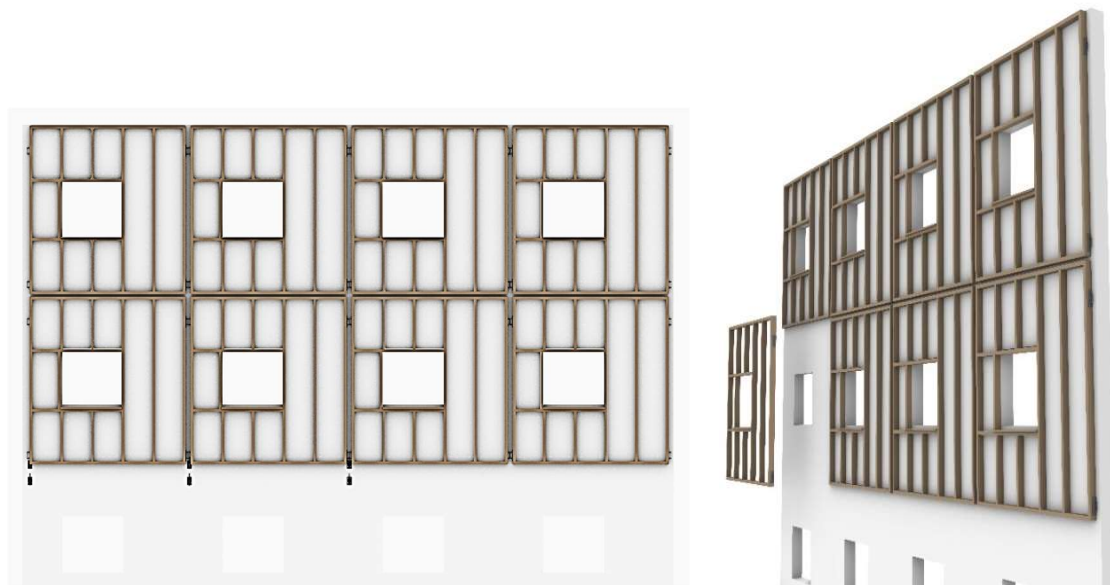

Figure 33, timber frame modules based on the dimensions of the opaque and transparent part of the existing façade

ENERGY REDUCTION PRINCIPLES

The principles that will be followed in order to reduce the energy consumption in the existing buildings are based on passive and active measures. According to these measures, a list of energy components was created to translate the basic principles of passive and active design, into tools and elements that will be integrated in the façade system to reduce the energy demand of a building. To create the adjustable façade system, the

adjustability of the structural part of the system is not enough. The energy components of the system, have to incorporate adjustability properties as well, otherwise, the compatibility between the structural and the energy reduction part of the system is not feasible. There are specific properties that render these components compatible with the adjustable structural system.

In order to reduce the complexity of the system, most of the energy components that are selected for the system are based on passive design principles, as the active measures use more subsystems to support the active function, a fact that will create more difficulties during the process of the renovation. The Table 11 shows the energy reduction elements that can be included in the system. The selection of these elements has been made with the precondition that all can create different combinations and are compatible with each other. The energy reduction components are also compatible with the structural part of the system. Different elements can be chosen as each one has different specifications. The selection of the appropriate element depends on the climate and the building envelope characteristics and the functions where the facade system will be applied on.

The table contains a brief description of each energy reduction element, energy reduction specifications, dimensional properties, and product name. The following are the pros and cons of each item in order to help better understand how the items can be used in the facade system.

Table 11(a), Passive and active design elements of the façade system for energy reduction.

Description	Specifications	Dimensions	product	Link
Insulation Mineral wool Is a rigid mineral wool insulation sheathing board that is non-combustible, water-repellent, fire-resistant and sound absorbent. Is an exterior non-structural insulation sheathing that provides a continuous layer of insulation around the commercial or residential building envelope.	Thermal conductivity: $\lambda=0,040$ (W/mK) U-value=0,3 for 13 cm thickness Non flammable Water and moisture-proof produced in sheets relatively low embodied energy 16,8 MJ/kg	(610 mm x 1219 mm) (914 mm x 1219 mm) (1219 mm x 1829 mm) (1219 mm x 2438 mm) Thicknesses (31.8 mm), (38.1 mm), (50.8 mm), (76.2 mm)	ROCKWOOL COMFORTBOARD™ 80	www.rockwool.com/north-america/product-page-applications/products/comfortboard-80/selected-categories#25856a252090%20downloads&52specifications&52
Plasterboard with water proof Cement Board Outdoor is a solid, engineered wall and ceiling lining made from inorganic aggregated cement embedded in both front and back surfaces with coated glass fibre mesh. PERMAROCK® Cement Board Outdoor has all the properties required for external wall and ceiling linings that must withstand harsh weather conditions.	Thermal Conductivity $\lambda=0,19$ W/mK R value= 0,035 m ² K/W	thickness 13 mm Width 1,20 m Length 3 m Weight 16 kg/m ²	PERMAROCK® Cement Board	https://knauflsol.com/usa/content/uploads/2015/02/Knauf-Permarock-Board-Outdoor-Oct-2014.pdf
windows (mild climate) Aluminum window frames with thermal insulation. The Tilt & Turn system combines outstanding thermal insulation performances along with high construction flexibility combined with different glazing thermal properties according to the needs.	Double glazing 20 kg/m ² Double glazing 4-6-4 emissivity $\epsilon=0,89$ U-value=3,3 (W/m ² K) OR Double glazing 20 kg/m ² with low E 4-6-4 emissivity $\epsilon<0,05$ U-value=2,5 (W/m ² K)	Adjusted in different dimensions according to the needs	Hinged insulated system SMARTIA S67	https://www.alumil.com/international/specifiers/products/windows-doors/hinged-insulated-system-smartia-s67
windows (cold climate) Aluminum window frames with thermal insulation. The Tilt & Turn system combines outstanding thermal insulation performances along with high construction flexibility combined with different glazing thermal properties according to the needs.	Double glazing 20 kg/m ² with low E 4-6-4 emissivity $\epsilon<0,05$ U-value=2,5 (W/m ² K) OR Double glazing 20 kg/m ² with low E+ argon gas 4-12-4 emissivity $\epsilon<0,05$ U-value=1,3 (W/m ² K)	Adjusted in different dimensions according to the needs	Hinged insulated system SMARTIA S67	https://www.alumil.com/international/specifiers/products/windows-doors/hinged-insulated-system-smartia-s67

Table 11(b), Passive and active design elements of the façade system for energy reduction.

<p>windows (extreme cold climate)</p>	<p>Aluminum window frames with thermal insulation. The Tilt & Turn system combines outstanding thermal insulation performances along with high construction flexibility combined with different glazing thermal properties according to the needs.</p>	<p>triple glazing with 2 low E 4-6-4-6-4 emissivity= <0,05 U-value=1,6 (W/m2K) OR triple glazing with 2 low E+ argon gas 4-6-4-6-4 emissivity= <0,05 U-value= 1,2 (W/m2K)</p>	<p>Adjusted in different dimensions according to the needs</p>	<p>Hinged insulated system SMARTIA S67</p>	<p>https://www.alumil.com/international/specifiers/products/windows-doors/hinged-insulated-system-smartia-s67</p>
<p>Blinds for Sunshade</p>	<p>Quick and easy installation due to lightweight blinds. Sun shading is supplied pre-assembled, ready for installation and already rolled up on the drive shaft. Automatic setting of the top end position. An integrated sliding guide in the curtain helps to eliminate the need of mount piping in the guide rails. High degree of prefabrication.</p>	<p>Reduces solar heat gain in buildings. High level of transparency around 25 %. The user retains connected with the exterior environment.</p>	<p>Adjusted in different dimensions according to the area that needs to be shaded.</p>	<p>Schüco Sun Shading System CSB</p>	<p>www.schueco.com/de/en/fabricators/products/sun-shading-systems/roll-lame/lamella-systems/cabinfronstoffw50-60/#accordion-310926</p>
<p>Louvers as Sunshade</p>	<p>Louver protects windows and entrances from the sun, either as individual units or as a series of interlocking units covering the whole wall. The louver also efficiently prevents glare and distracting reflections from outside, thus improving working conditions, work safety, and enhancing overall comfort of the interior. It is very low-maintenance due to its robust structure.</p>	<p>Aluminium</p>	<p>Adjusted in different dimensions according to the area that needs to be shaded.</p>	<p>Alupro</p>	<p>https://www.alupro.com/en/products/façade-solutions/louvers/wing-louvers/</p>
<p>Façade solar panel</p>	<p>High-performance photovoltaic modules for the building façade using concealed mounting clasps. In addition, this system offers extensive design possibilities and is in widespread use in commercial, public, and private buildings.</p>	<p>Rated power [W] P= 105,00 Rated voltage [V] V= 80,80</p>	<p>standard dimension 120x60 cm color variation</p>	<p>NICE CIGS modules (Copper Indium Gallium Di-Selenide)</p>	<p>https://nice-solarenergy.com/en/cigs-modules.html</p>

Insulation (mineral wool):

(+) The thickness of the insulation can be varied by adding more than one layer of mineral wool on top of each other until the desired energy result is achieved. The flexibility of the mineral wool as insulation material helps in the easier application of the insulation between the structural elements during the assembly process of the panel and covers with greater ease any gaps which create thermal bridges.

(-) The negative impact in the façade modules from the mineral wool is not related with the material itself but with the increase of the insulation thickness. In case of a thicker insulation layer is needed, the total thickness of the timber frame increases, with the result the system becoming heavier. Hence during the selection of the energy components, we need to aim at the most optimized solution that not only contributes to the reduction of the energy demand of the building, but also take into account more parameters such as structural stability of the system and the exposure to the natural light. In some cases, thick modules could reduce the natural light in an existing window as the total thickness of the wall increases.

Windows:

(+) The properties of the windows consist of two functions that make them appropriate for the overall adjustable façade system. The first refers to the structural part and the second is related to the energy reduction part. The first characteristic is the ability of the insulated window frame to take different dimensions according to the dimensions of the facade module. The second is the

different variations in the properties of the glass panes as they can vary from double glazing to triple glazing with more than one alternatives by adding low E coatings or special gas between the glass panes for even less thermal transmittance.

(-) The limitations in the case of the windows are related to the energy reduction needs and the different variation in the thickness and weights that the window can have. For instance, a triple glazing window weighs 10 kg per m² more than a double glazing and the thickness of the frame is increased, a fact that leads to a thicker and weightier facade module. To avoid extra material and weight due to the triple glazing different combinations of properties can be applied such as double glazing with low E coatings and special gas between the panes. If the result cannot achieve the energy reduction goal, then further optimization in the structural part of the system has to be made to support the extra weight.

Plasterboard (waterproof):

(+) The selection of the specific product gives the opportunity to the façade system to withstand very harsh weather conditions a fact that is very convenient for a system that has to be adjustable in different climates with different weather conditions.

(-) Due to the specific dimensions of the plasterboard 1,20 by 3 meters, it might be necessary to combine and attach together more than one plasterboard to cover a façade module. While on the one hand, it is easy to cut the material and adjust it into the appropriate dimensions of the facade modules, it would be more convenient during the assembly process to have the option of one piece plasterboard in the preferable dimensions.

Blinds for Sun shading:

(+) This component is selected for the energy reduction properties that can give to the system. The properties of the specific product that makes it suitable for the façade renovation system are the ability to adjust in different dimensions according to the needs, reduce the solar heat gain when it is needed, and withstands in all the weather conditions.

(-) The drawback of this element is that in order to reduce the solar heat gain at the same time reduces the visual connection with the exterior environment. However, the ability to open and close in different positions can eliminate the problem when the sun changes position during the day.

Louvers for Sun shading:

(+) This energy component is selected to be in the list of options for the energy reduction methods of the system, as it can reduce the direct sunlight and reduce the overheating due to the sun. In addition, the width and length can be cut into various dimensions according to the needs. The angle of the louvers can be fixed according to the specific orientation and location of the building.

(-) The permanent position of the louvers in front of the openings in the façade modules might create shading issues during the year as the height of the sun changes position and cannot be efficient for every season of the year. Additionally, the space between the louvers to achieve the best shading result can come in conflict with the visual comfort of the building users.

Façade solar panel:

(+) This energy component is suitable for the integration into the façade modules of the system as it is very lightweight, it can be applied easily on the external part of the facade modules and can produce sustainable energy.

(-) The standard sizes of the PVs have to be taken into account during the design process of the facade modules in case that PVs have to integrate into the facade renovation system.

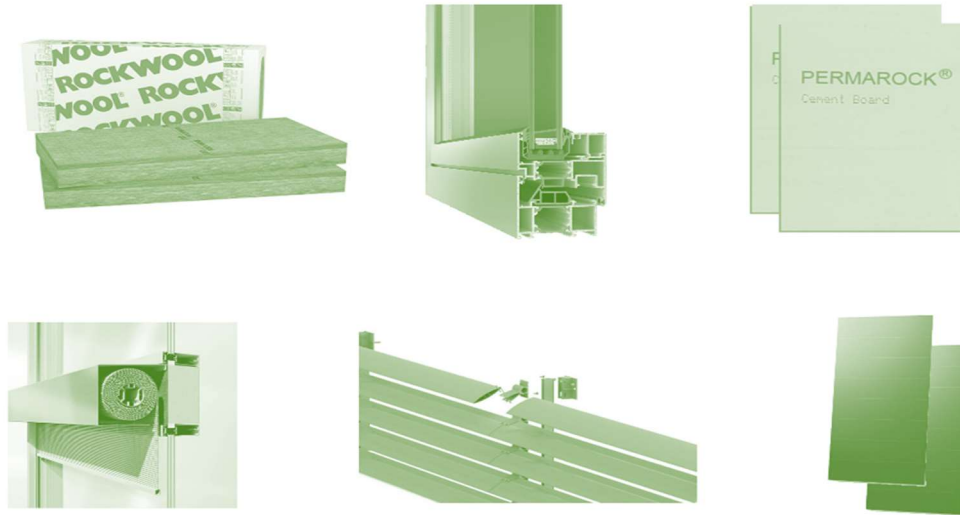

Figure 34, energy reduction components

EVALUATION OF THE ENERGY REDUCTION COMPONENTS

The energy reduction elements have the capability to adjust according to the design needs. The list (table 11) of the energy reduction components has been created with the aim of selecting the appropriate element to reduce the energy consumption of the existing buildings. The way of selecting the appropriate energy components is done through the knowledge acquired during the literature research and their performance evaluation through tools and calculations based on the energy properties of each element.

To evaluate the selection of the combined elements energy performance of each combination of elements before and after the application of the system and estimate the energy savings, there are tools that can be used in order to have the most suitable result. The tools consist of hand calculations and software simulations. More specifically the process that will be followed in order to evaluate the energy performance in the renovation system is by defining the U-values of the elements for every case. The process is as follows:

1. Firstly, the U-values need to be calculated for the opaque and transparent surfaces per square meter of the existing building, based on the characteristics and the material properties. To define the U-

value of the opaque part the use of the “Ubakus” online software is used while hand calculations are used for the transparent part.

2. The next step is to calculate the heat losses per square meter surface using the formula that includes the climate characteristics of each location. The climate characteristics can be rendered by adding the Heating Degree Days (HDD) and the Cooling Degree Days (CDD). The formula for the heating demand during the heating season can be calculated with the formula **$Q_{\text{heating}} = U_x A_x \text{HDD} \times 24 \times 3600$ [J]** assuming that there is no sun. As far as the energy demand during the cooling season the formula is **$Q_{\text{cooling}} = Q_{\text{transmission}} + Q_{\text{sun}} = U_x A_x \text{CDD} \times 24 \times 3600 + q_{\text{sun}} \times g \times A_{\text{window}} \times t$** , where (q_{sun}) the average solar irradiation on the window in W/m² during the cooling season and (t) the length of the cooling season in seconds. The determination of the average solar irradiation can be found by using the “Climate Consultant 6” tool. By using this formula which includes the U-values of the materials and the specific climate characteristics of the location (HDD and CDD) it is possible to achieve a first estimation about the current energy demand.

After the determination of the energy situation of the existing building envelope, the next step is to decide what are the appropriate energy reduction elements for the renovation that needs to be intergraded in the new system. This is a step follows the design principles and the guidelines from the literature research and based on different aspects such as the climate the orientation or the function that the existing building envelop has.

3. After the selection of the most suitable energy components according to formulated knowledge from the literature for the new façade system, the same method will be followed as in the existing façade, to define the U-value per square meter of the new façade system for the opaque part by using “Ubakus” and for the transparent part using hand calculations.

When the Energy demand per square meter surface for both existing façade and new façade system have been calculated, a further distinction has to be made based on the surface where the system will be applied on. There are two options to calculate the overall energy demand and the impact of the new façade system in the building energy consumption.

- The first option is when the system is going to be applied on a flat wall façade. In this case, the overall new energy demand of the opaque and transparent part after the application of the system is the one that has been calculated for the new façade system due to the fact that the external new building envelope consists of the new system. Therefore, the final energy demand after the application of the system can be estimated by using the formula Q_{heating} and Q_{cooling} of the new system without taking into account the existing construction.

A remark in this stage that needs to be clarified is that when the new system is installed, the old glazing is removed and the integrated windows of the facade modules are the final windows of the building.

The impact of the retrofitting system is quantified as the reduction in the current energy demand and can be expressed by the percentage of the reduction in current demand, calculated with the following formula: **[100x (Current Demand-New demand)/ Current demand] %**. Expressing the improvements on building performance as a percentage of reduction in the current energy demand has the advantage of tackling the uncertainties of the calculations.

- The second option is when the system is applied on building with balcony. In this case, the temperature weighing factor is added for the calculations, $\alpha = \frac{U_e A_e}{U_e A_e + U_i A_i}$ with U_e the U-value of the external facade system and U_i the U-values of the existing building surface. This step is necessary because the building envelope transformed into double skin facade. In order to have an estimation about the energy demand after the application of the system we need to multiply the weighing temperature factor with the heat loss of the existing facade. **$Q_{new} = Q_{existing} \times \alpha$ [J]** following the same method as in the first case, the impact of the retrofitting can be quantified as the reduction in the current energy demand. And can be expressed by the percentage of the reduction in current demand.

As far as the impact from the shading is concerned, simple simulation tools such as the **Passive Design Assistant** (PDA) will be used to check how much the shading system can decrease the interior temperature of a room. This software gives the opportunity to the user to adjust the dimensions of the louvers, the spacing, and the inclination of the blades in order to get the most suitable solution. The impact of the shading system is depicted through the interior space temperature on a characteristic day. Different variables such as geographical characteristics (altitude and latitude) of the point of interest can be used in the software in order to get a more accurate result as the height of the sun varies, especially in the different European countries. Using all these parameters it is possible for the user to make plenty of simulations and check what combination is the most appropriate for each renovation project.

Additionally, in order to define the percentage of the direct sunlight into the windows the "Sun-Hours" plug-in for Sketch-Up will be used to define the impact of the shading system that has been formulated in the PDA software in terms of g value, by analyzing the percentage of the direct sunlight on the transparent surfaces. Thus it will be known how much reduction in the g-value can be achieved with the specific shading system.

ATTACHMENT SYSTEM PRINCIPLES

The building envelopes have different architectural characteristics that affect the way that the system will be attached to existing building envelopes. These characteristics can vary from a flat opaque wall façade with openings, the external common hallway, or private balconies.

These alterations in the building envelopes create a further distinction on how the system can take different attachment variations according to the existing building envelop characteristics. There are three types of attachment that can be combined in order to achieve the aim to cover the existing building envelop with the facade system for energy reduction.

a. For flat wall facade:

If the wall can support extra weight, then metallic adjustable hooks are placed with bolts on the existing surface and the façade modules are attached to them. This attachment refers to concrete wall construction. If the wall is not capable to support more weight, a series of external timber supports are placed with metal adjustable hooks in front of the wall to transfer the loads of the façade modules to the ground. This attachment methode is suitable for brick wall masonry.

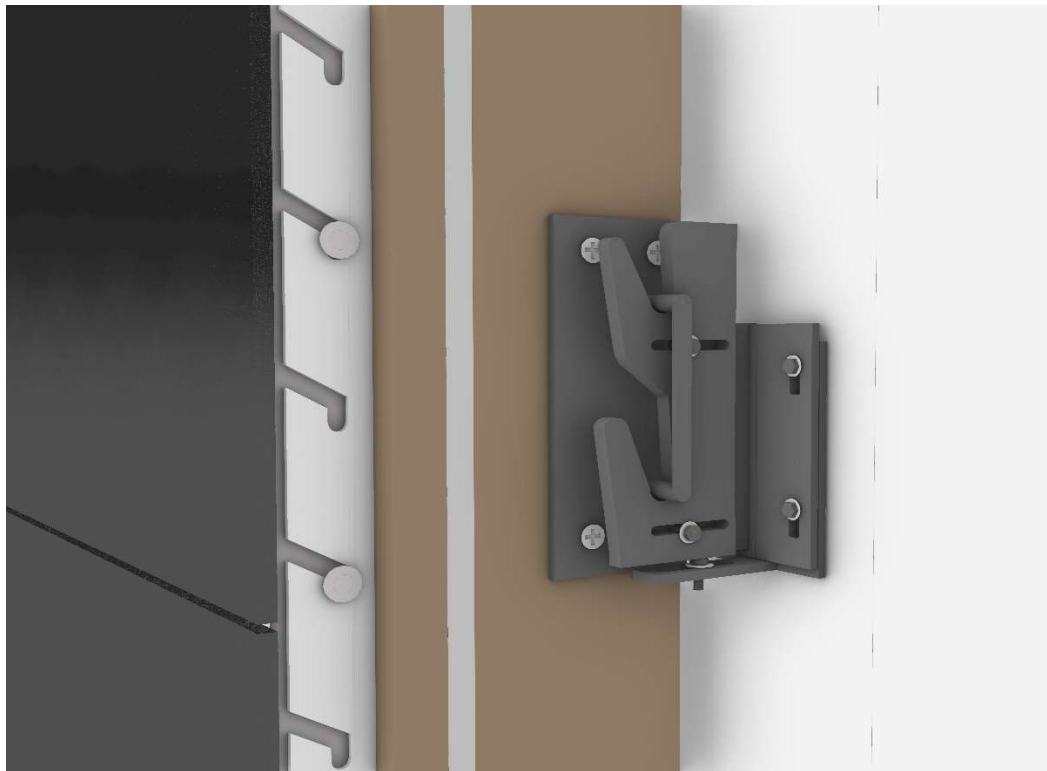

Figure 35, Connection system for flat wall façade capable to support the extra weight of the façade system modules

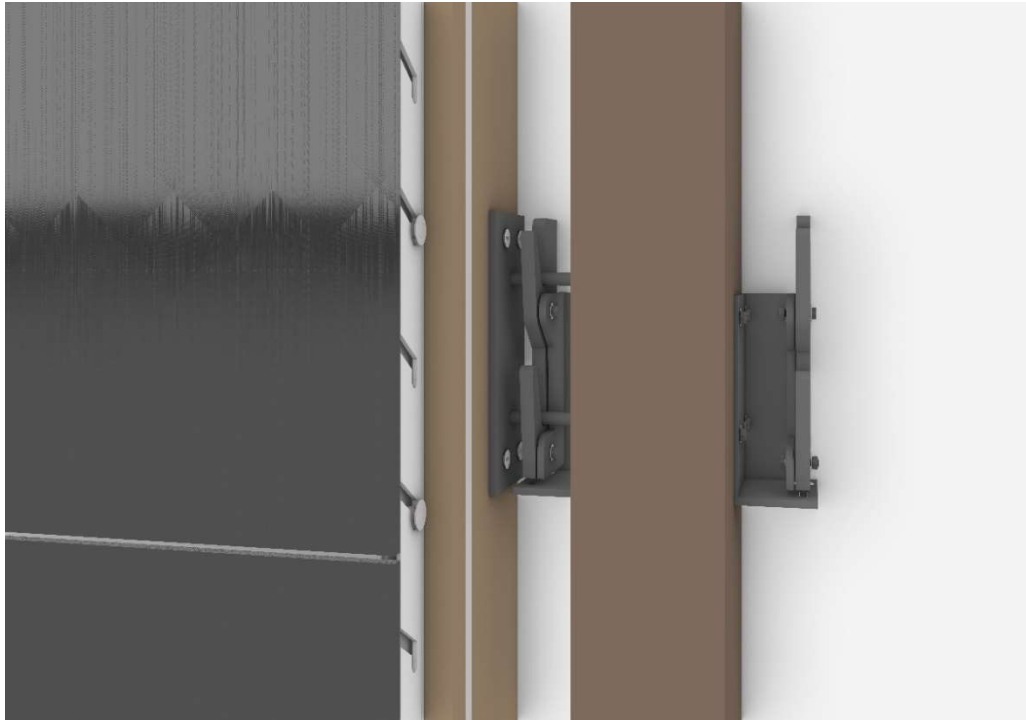

Figure 36,, Connection system for flat wall façade that is not capable to support the extra weight of the façade system modules

b. For balconies and external corridors:

A support system with metal brackets for the façade modules is placed between the building concrete slabs. By placing timber supports in the external part of the building a new substructure is created to support the façade modules. The support system apart from creating the necessary surface for the modules has the function to transfer the loads of the modules to the ground. The details of the façade frame will be shown in the “Generic Design variations” section.

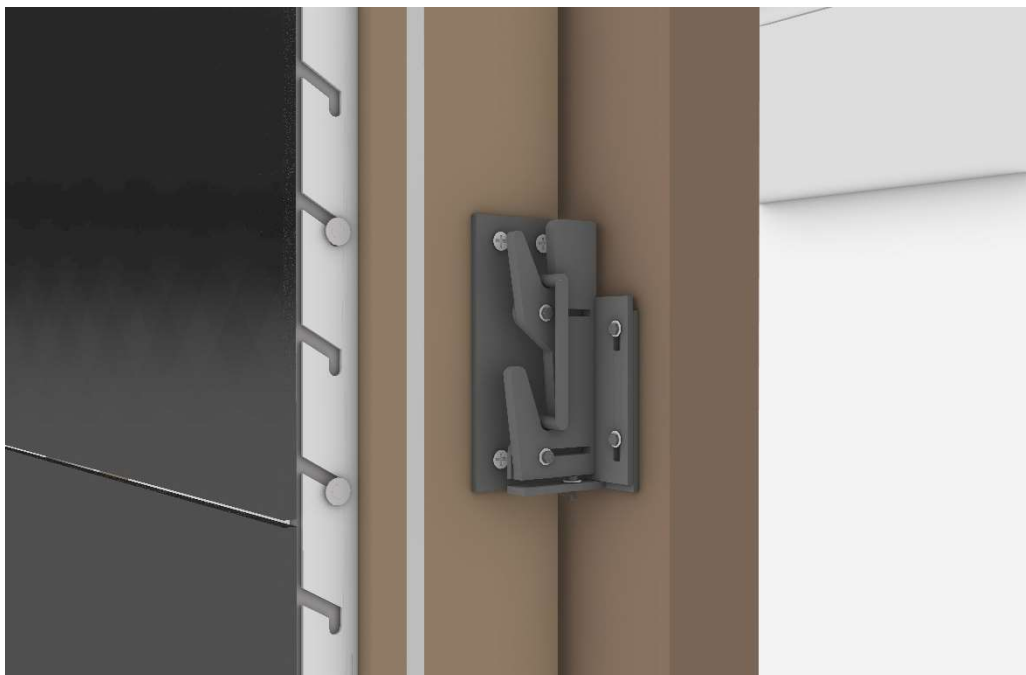

Figure 37, Connection system for balcony and external corridor

The connectors are the main elements that make the system easy to apply on existing surfaces. The material of the connectors is out of stiff metal due to the heavy loads of the facade modules that need to support. In addition, the design of the connectors has been shaped with the aim to achieve easy access during the installation process of the modules with the use of a crane and without scaffolding, in order to make the application process of the facade modules faster and easier.

Even when the surfaces look flat on one side of a building, there are often surface irregularities, which means that if the units are applied to such surfaces, there will be no good contact with the existing wall, or even worse, it may be impossible to apply the system.

Therefore, the adjustability of the connectors in different directions plays a crucial role in the smooth application of the system. For this reason, the connectors have been developed to being adjustable in two directions in order to reduce the unevenness of the existing envelope as much as possible. The metal hooks can cover surface irregularities up to 45 mm in the direction perpendicular to the wall and 20 mm in height.

The setting of metal connectors on the existing surface is based on the dimensions of the facade modules that have been defined during the process of the facade grid determination for the modules of the system.

The first goal is to align the connections in the vertical and horizontal axis. When the connectors are aligned, a further small adjustment on the connector itself can take place to minimize the inconsistencies of the existing building surface. When every connector is aligned with the others, the modules are ready to be placed.

As far as the tolerances between the modules and the hooks are concerned, there is a tolerance of 40mm between the metal hooks and the side timber beam which incorporates the metal hinge for the connection between the module and the existing building as is illustrated in figures 35,36,37 this makes a maximum tolerance of 80mm between the two modules. This gap between the modules is necessary in order to have access to the hooks during the installation process. The gap will be covered with mineral wool after the installation of the facade system to limit thermal bridging and increase the airtightness of the system.

Regarding the tolerances between the top and bottom sides of the modules are 40mm as there is no need for the extra process after the application due to the fact that every module will be covered with 20mm of mineral wool for the same reasons as in the vertical sides. The difference in these sides is that the insulation would be integrated into the modules before the installation and when the modules are placed the soft form of the insulation will adjust according to the gap between the modules.

6.3 Generic Design Attachment variations

In this section, three different variations of the façade system are presented with the aim to clarify the potential application challenges that the renovation system could face. The details of the system show how the system can be applied in buildings with a concrete masonry wall, in buildings with a brick wall, and in buildings with balconies. The lengths and widths of the system can vary according to the building characteristics, the selection of the energy reduction elements and the functions of the building envelope. The cladding material is indicative since the material can vary depending on the needs. Thus, a generic module without specific dimensions is used with the aim to represent the technics and the design principles that will be followed in every renovation case. These variations are not the actual aesthetic design result of the facade module, as every renovation project can have different architectural variations approaches.

The first case scenario is the attachment to a concrete wall. This option is the simplest, as the metallic hooks are the only thing that is necessary for the application of the modules. However, some important factors have to be included in the design, to minimize the thermal bridging. The use of thermal insulation between the facade modules is necessary. A layer of mineral wool has to be placed between the façade modules and the existing wall to eliminate the inconsistencies of the existing wall and achieve better airtightness. Extra insulation is added for the same reason between the modules and covered with a thin aluminum profile to protect the insulation from weather conditions.

The second option is the attachment to a brick wall. In this case, an extra substructure is necessary to support the modules as the bricks cannot support the weight of the façade renovation system. For this purpose, timber supports are placed on the existing surface based on the dimensions of the modules. The connection of the supports to the building is achieved with the use of metallic corner plates while a necessary gap is created for the mineral wool between the façade system and the existing wall as in the previous case. The metallic hooks are placed in the timber supports on both sides while extra mineral wool is added to avoid thermal bridges in the vertical axis between the supports and the modules. To cover and protect the insulation from weather conditions a flexible metallic profile is applied at the external part of the insulation as in the first case.

The third and last variation for the façade renovation system is the application in balconies. Due to the small external surface areas of the concrete cantilevers, the system cannot be applied with only the use of metallic hooks, because the vertical position of the hooks needs enough space to attach the modules on both sides. To solve this problem an extra subsystem is necessary. This system consists of timber supports that are positioned with metallic bases between the concrete slabs and incorporate the metallic hooks for the modules. In contrast to the previous variations, the internal part of the facade module has a finishing layer of plasterboard as this surface will be the new internal surface of the exterior wall which in this case the new exterior wall consists of all the facade modules of the renovation system.

Option 1_ Application in concrete wall

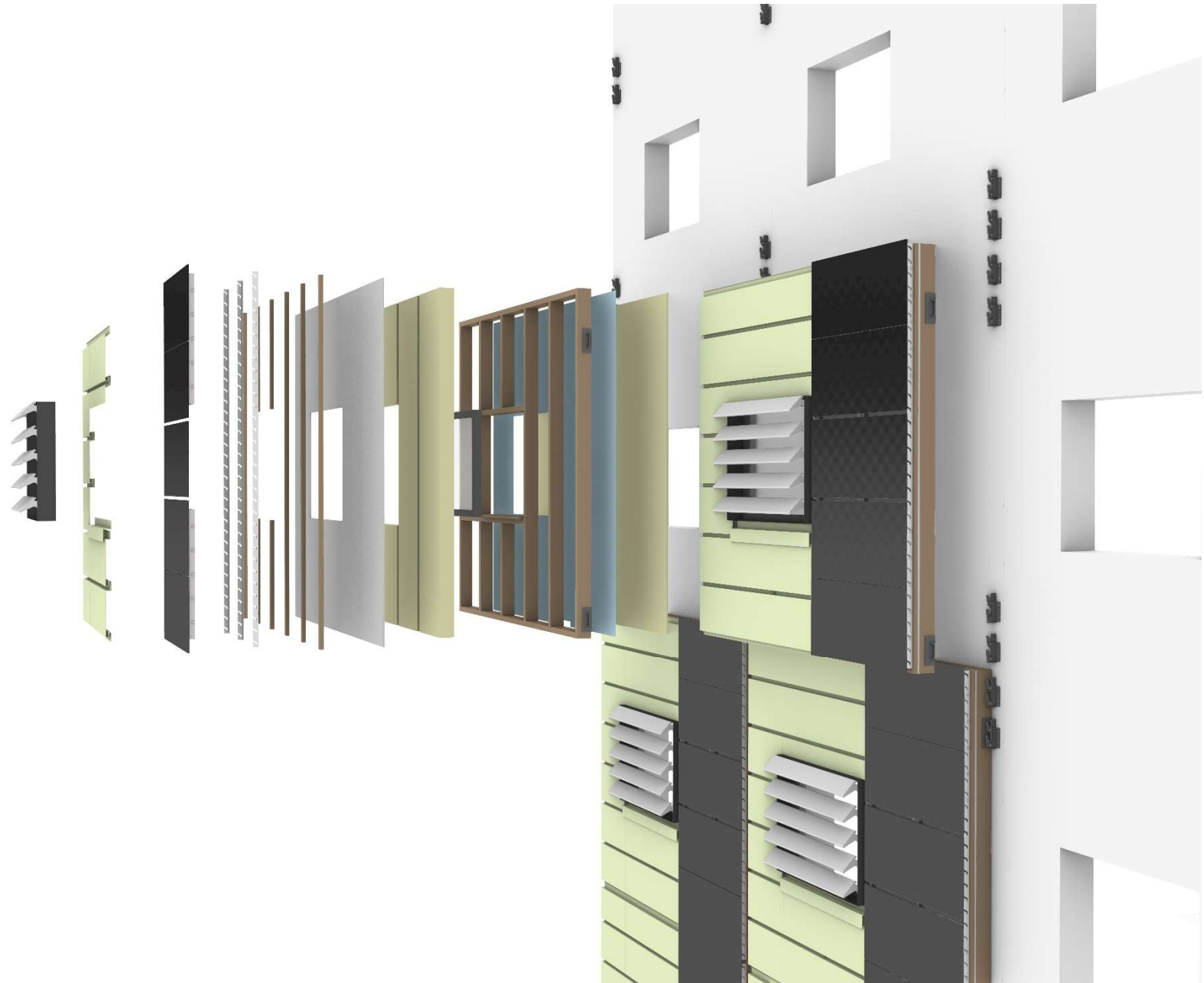

Option 1

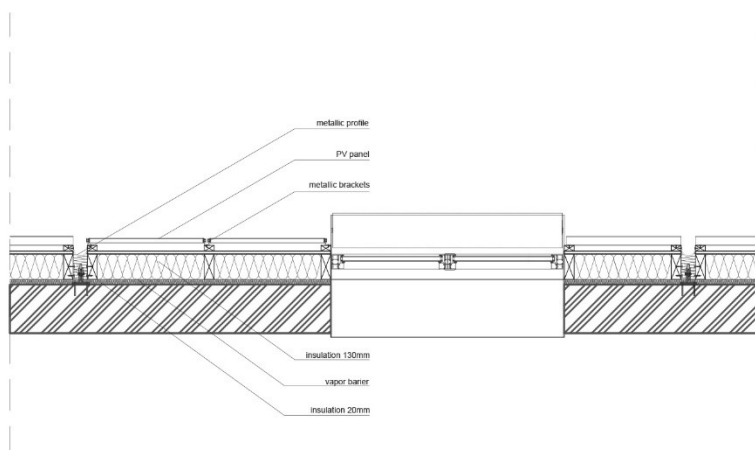
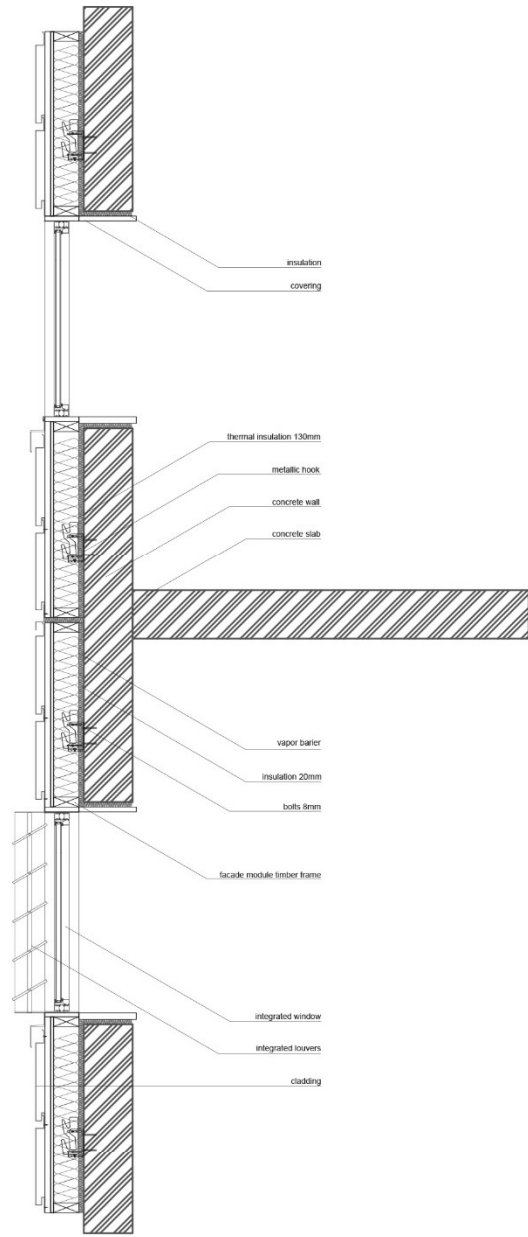

Attachment details 1

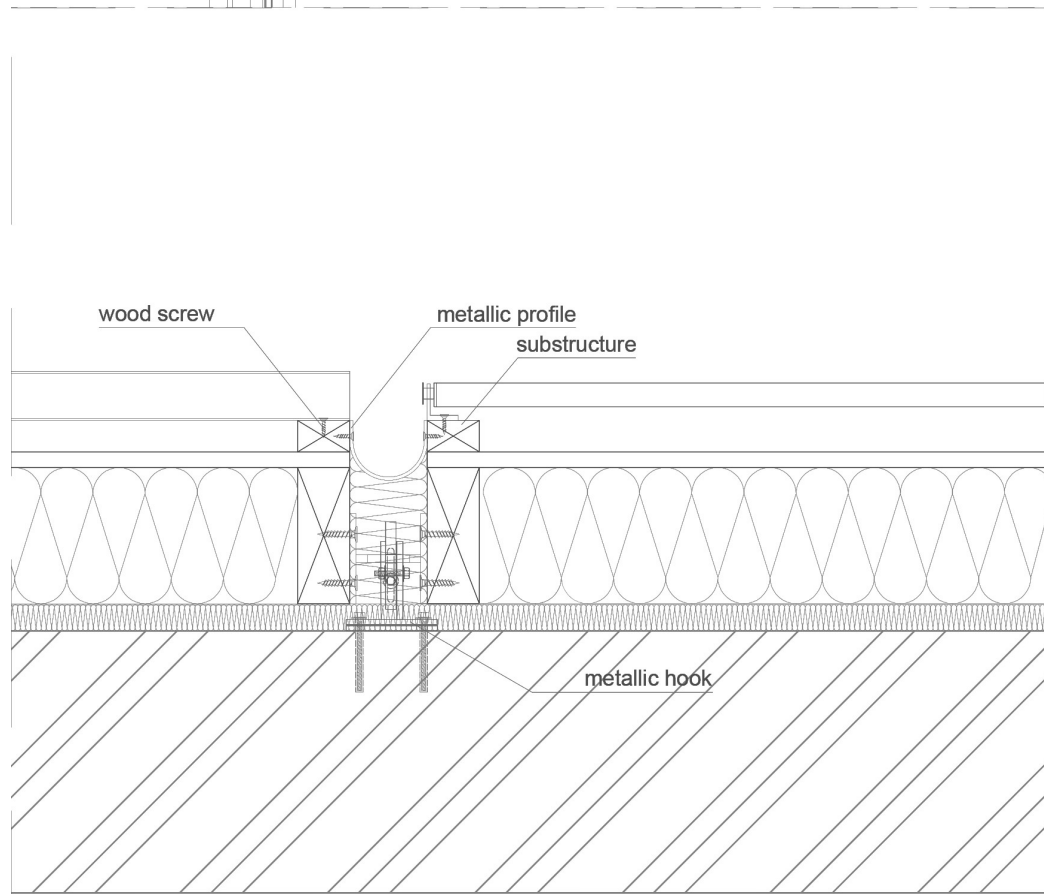
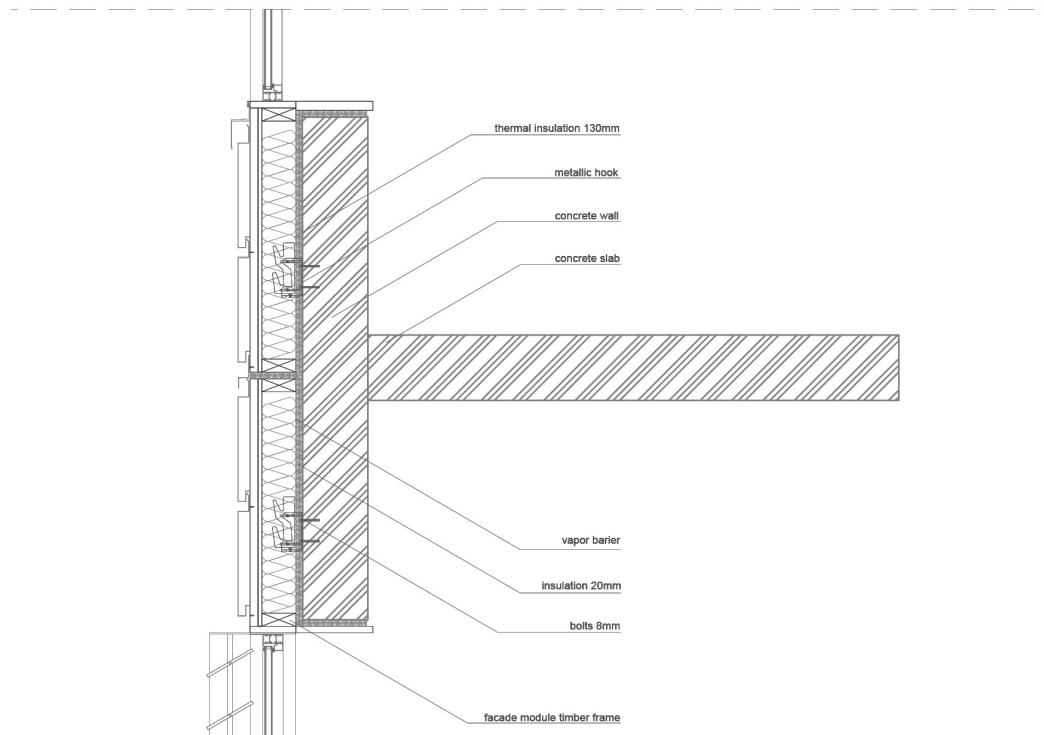

Option 2, Brick wall

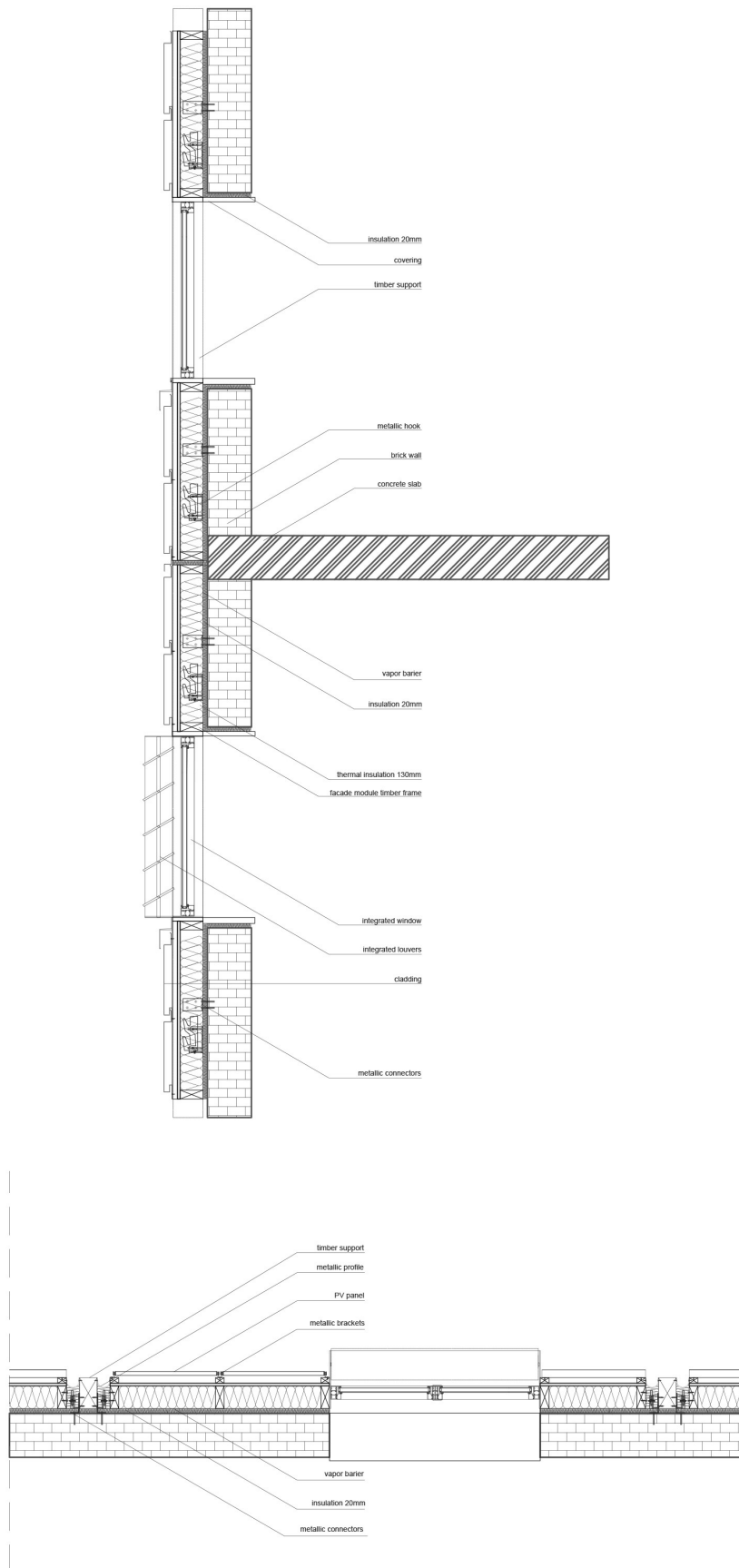

Attachment details 2

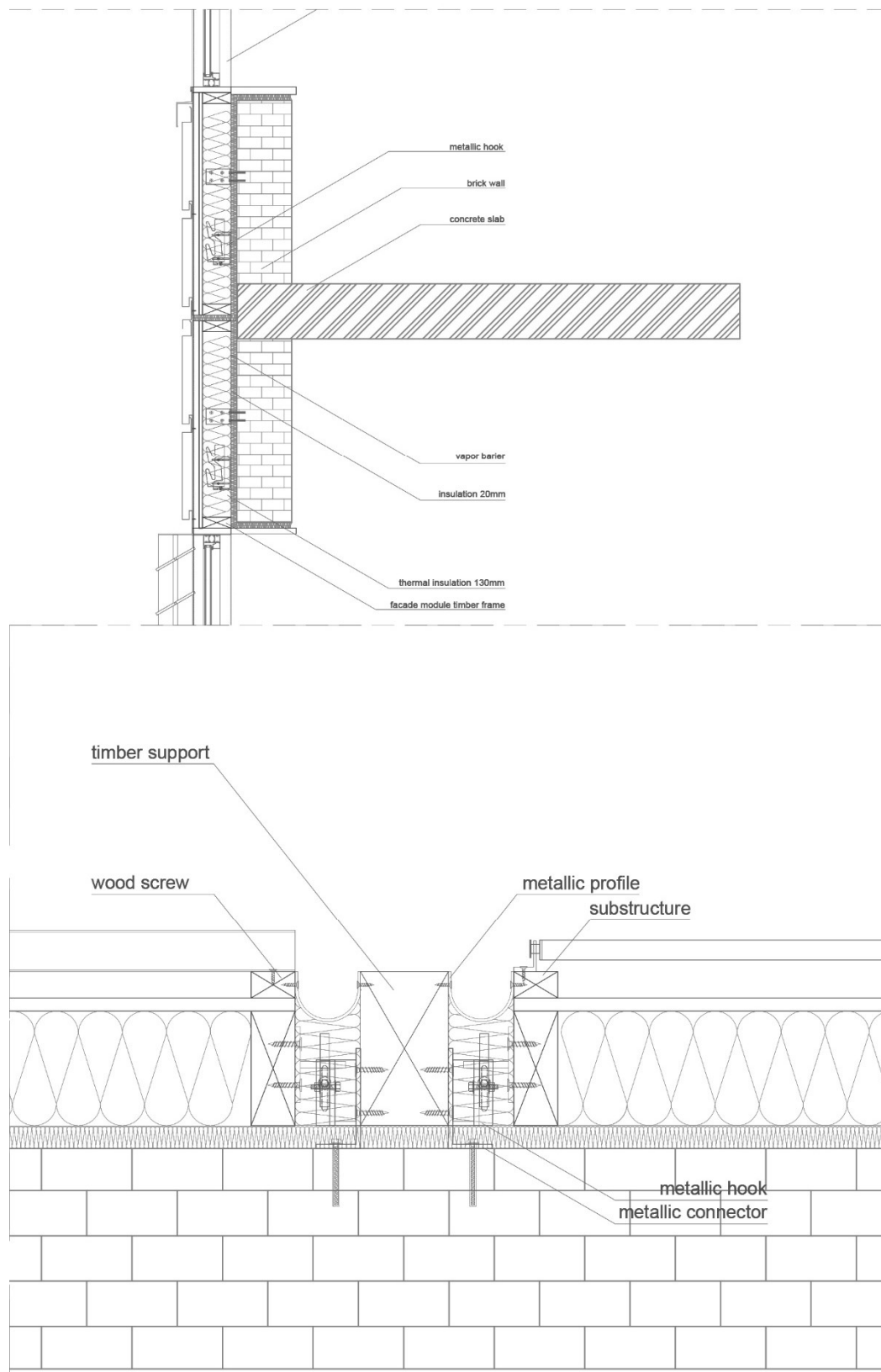

Option 3_ Application in balcony

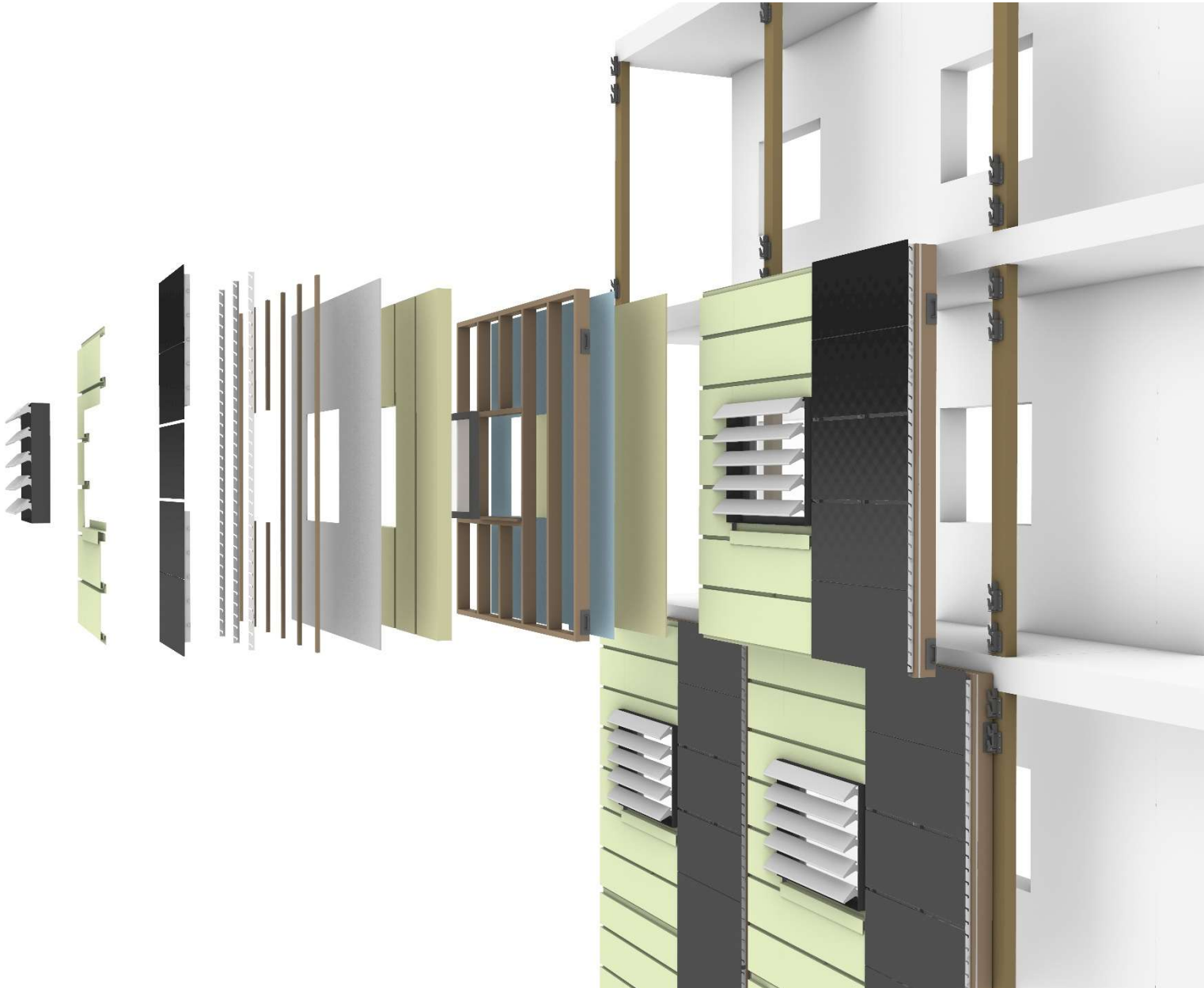

Option 3, Balcony

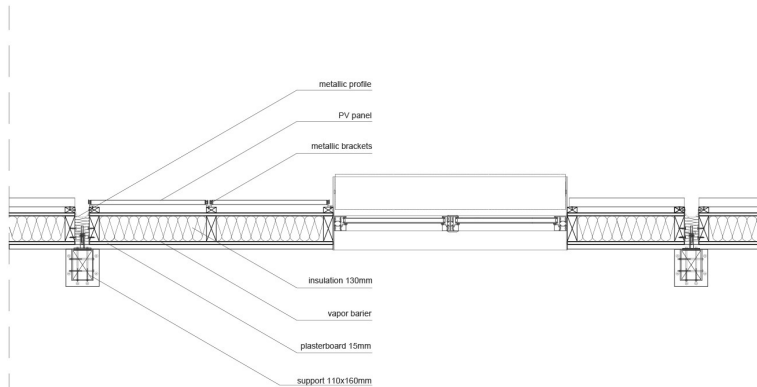
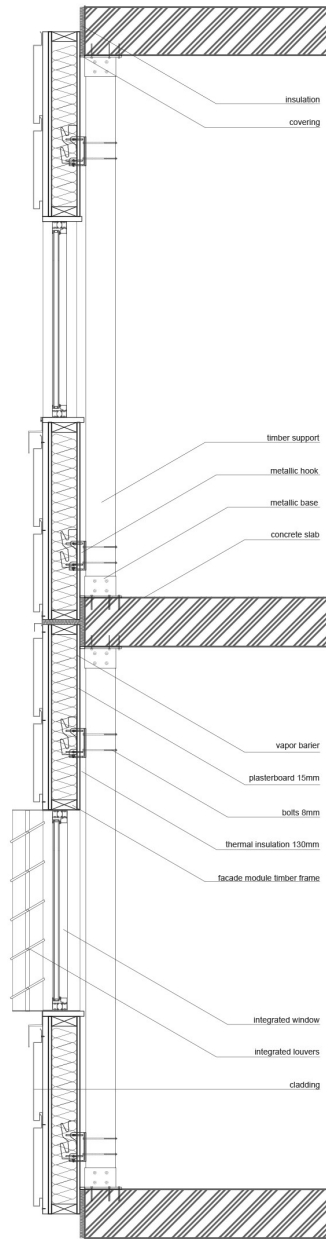

Attachment details 3

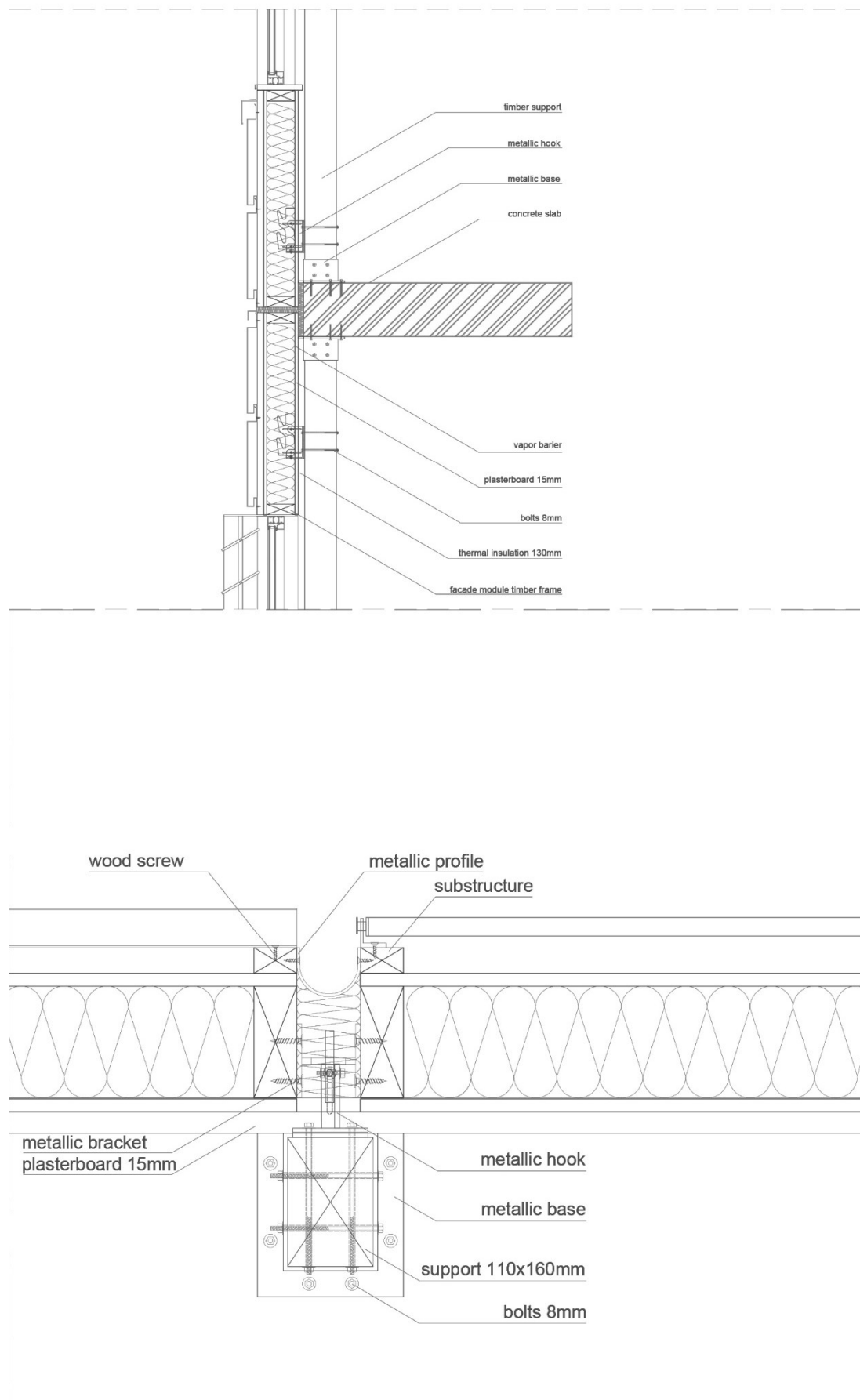

7. Case study buildings

In order to evaluate the façade system for energy reduction renovation, two case study buildings have been selected to apply the system. The characteristics of the buildings have been determined based on the climate, the typology, and the function of the building envelope.

The adjustability of the renovation system in different climates around Europe is one of the main principles of the system that will contribute to establishing a larger scale renovation approach for the European countries. Due to the countries in Europe have different climate conditions the two case study buildings belong in different climates with the aim to represent two different weather scenarios to evaluate the system adjustability. The first building is located in Amsterdam, The Netherlands. According to the Koppen-Geiger climate classification, the climate in Amsterdam refers to a mild cold climate. The second location is in Athens in Greece, and according to the Koppen-Geiger climate classification, the climate in this region refers to a mild warm climate.

Apart from the adjustability of the system in different climates, the system is designed in such a way as to be applicable in specific building types but in different typological characteristics. The building type refers to the Residential buildings while the typology refers to the kind of building envelope characteristics.

The residential buildings have been selected as the most suitable building type due to the reasons that have been mentioned in Chapter 4. Choosing the renovation of this type of building using the facade renovation system to reduce energy consumption will have the greatest impact on the environment not only because they represent the largest percentage in the total building stock, but also because residential buildings consume the most energy due to the poor energy construction characteristics based in past regulations.

As far as the function that the building envelope is concerned, there are three spatial functions that the system can be applied, to cover all the different aspects that a residential building can have. The first is the application on a flat wall facade, the second on a building with private balconies, and the third on a building with a common external corridor. In the next sections, the two case study buildings are analyzed in terms of basic measurements and building functions as well as the current energy performance.

7.1. Typologies and basic measurements

Case study in Amsterdam

The first case study building is located in the Netherlands and has been selected due to its typical typological characteristics that can be found in many north European countries.

The first case study building is a nine-story residential building in Amsterdam. The building has been selected to show the different potentials of the facade system for energy reduction renovation. More specifically, the building envelope incorporates four different functions, a balcony with an external common corridor along the length of the dwellings, the same space on the other side of the building with private balconies and a flat facade with openings in the part where the vertical circulation is located and in the two small sides are balconies for circulation purposes.

Therefore, through this specific building can be demonstrated how the system can adjust in more than one building envelope characteristics.

The orientation of the building as figure 40 shows is aligned with 60 degrees from the north and all the sides are exposed to the weather conditions a fact that will take into account during the design process of the system.

Another main characteristic of the building that renders it appropriate for renovation with the facade system, is the repeatability of the floors and the position of the openings. This means that the new facade modules that will cover the building could be the same in the vertical axis, a fact that will reduce the cost of the system, while at the same time will decrease the construction time and create a more systematic renovation approach.

The ability of the system to cover the existing building surfaces creates a new dialogue between the new building envelope and the urban environment. For this reason, in addition to reducing the energy demand of the building with the implementation of the system, efforts will be made to improve the appearance of the building.

The current aesthetic of this building belongs to the past and the facade renovation system for energy reduction can also contribute to new building aesthetic standards by improving not only the energy performance but also the appearance of the building.



Figure 38, Netherlands, Amsterdam Location: Hoogoord, Year of Construction: 1968

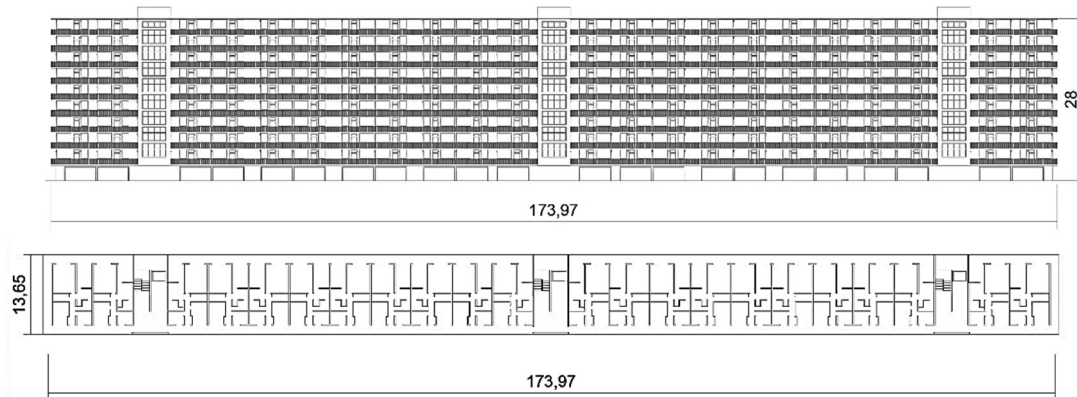

Figure 39, Elevation and plan of the building



Figure 40, orientation of the building and spatial relation of the building with the environment

Case study in Athens

The second case study building has been selected due to its typical simple construction character that can be found in Greece and in other southern European countries with a mild climate.

The building is a five-story building in Athens. The selection of this building as in the first case study has been made in order to show different variations of the facade system. In this scenario, the building in contrast to the Dutch one has only 5 floors and it is much smaller. In addition, the external part of the building has private balconies a fact that needs to take into account during the design process by implementing different design parameters than the ones in the case in Amsterdam.

The orientation of the building as it is shown in figure 43, the main façade is facing East and there are two building on the south and the west façade a fact that will take in to account during the design process as in the previous case study building.

The repetitive floors are also the case in this building as the repetition in the facade elements is a precondition in order to implement the renovation system. As in the previous example, the building shows signs of aging and there are no aesthetics criteria, as at the period when this type of buildings was built, the only goal was fast construction with as little investment as possible, due to the great need for housing in large urban centers.

As in the previous example, the renovation facade system will contribute not only to decrease the energy consumption but also to give extra value through the new building skin that will incorporate all the necessary elements to achieve both energy reduction and aesthetical upgrade goals.



Figure 41, Greece, Athens, Location: Amfitheas 24-26, Construction year: 1974

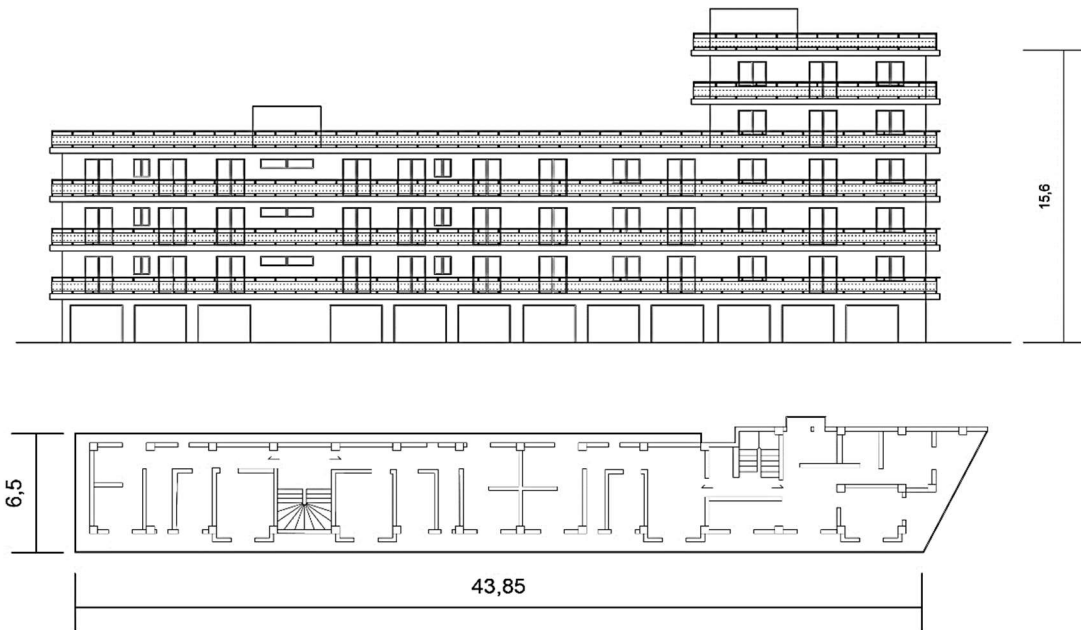

Figure 42, Elevation and plan of the building



Figure 43, orientation of the building and spatial relation of the building with the environment

7.2 Current energy performance

Apart from the different typologies and the functions of the building envelope, each building has different energy consumption characteristics that are related to the climate and the material properties of each construction. In this section, the current energy demand of the buildings is shown based on the material properties through the U-values. The U-value for the opaque part of the facade is determined through the Ubakus online software. As far as the transparent part of the existing facade is concerned, will be based on the standard U-values of a typical window with double glazing can have.

The energy demand for each case scenario will be calculated based on a typical apartment of each building. Hence all the energy reduction variations that the facade system can take, will be calculated according to a typical apartment in the next chapter where the façade system for renovation will be applied on the case study buildings.

AMSTERDAM EXISTING CONSTRUCTION CHARACTERISTICS AND CURRENT ENERGY PERFORMANCE.

The opaque part of the wall of the building in Amsterdam consists of cross-laminated timber and timber posts with U-value= 1.9W/(m²K).

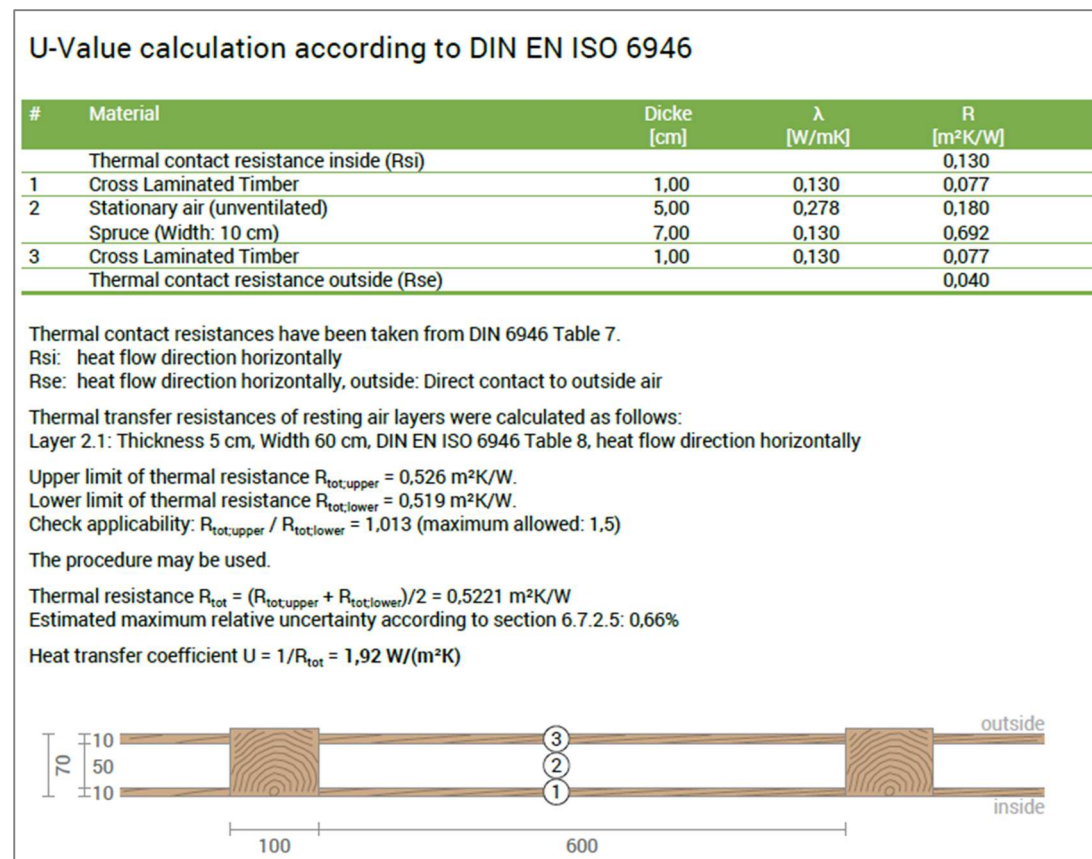

Figure 44, existing wall construction and U-value.

The transparent part of the facade that is used in the existing construction consists of simple double glazing windows with $U\text{-value} = 2.5 \text{ W}/(\text{m}^2\text{K})$

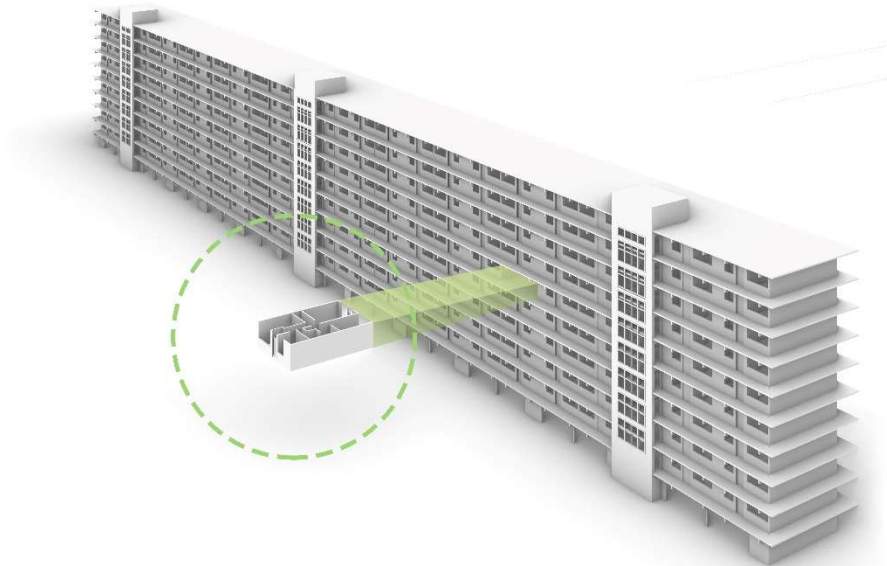

Figure 45, Selection of one typical apartment as a representative example of the building.

To estimate the impact of the solar irradiation during the cooling season in the current situation, the sun-hours plug-in for Sketch-up was used, in order to check how many hours are the existing windows exposed to the sunlight and what is the size of the window area that is affected. To achieve an accurate result three main parameters were used: the orientation of the building, the average solar irradiation on the window during the cooling season and the position of the windows.

The software "Climate consultant 6" was used to determine, the average hourly direct normal radiation for the months June, July, August. The average solar irradiation for these months is **qsun=190 W/m² per hour**. The g-value due to the double glazing windows is 0.7.

According to the sun-hours analysis, almost half of the total window area is exposed to the direct sunlight during the cooling season, due to the shading which is created from the balcony. As a result, to estimate the impact of the solar irradiation the g-value of the window that normally was 0,7 becomes 0,4.

The simulation apart from showing the window surface that is exposed to the sunlight shows the hours of exposure as well, and in this case, are around 500 hours during the cooling season.

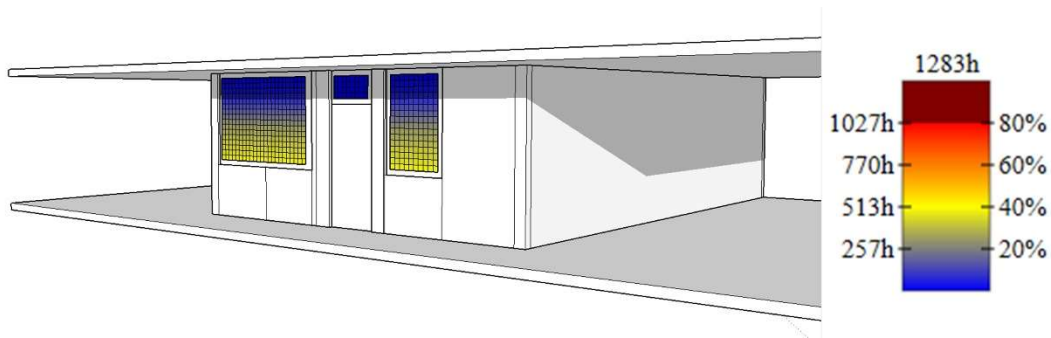

AMSTREDAM	Start time	6:00	Start date	1 June
simulation inputs	End time	20:00	End date	30 August

Figure 46, Sun-hours analysis of a typical apartment in building in Amsterdam in the South-East façade.

The current energy demand for a typical apartment in the building in Amsterdam is divided in two parts. The first is related to the heat transmission losses during the heating season and the second refers to the transmission losses and the solar energy during the cooling season. Therefore, according to the table 12 the energy demand during the heating season is 17.663 MJ and 3.069 for the cooling season respectively. The average demand per apartment is 10.366 MJ

The results is a combination of the different tools and calculations that have been described in In chapter 6.

Table 12, Current energy demand due to heat transmission and solar energy

Energy performance of the existing façade for a typical apartment	total surface area of a typical apartment (m ²)	Heat transmissions per square meter during the heating season. (MJ)	Heat transmissions per square meter during the cooling season. (MJ)	Current energy demand for heating of a typical apartment due to the heat transmissions.(MJ)	Current energy demand for cooling of a typical apartment due to the heat transmissions.(MJ)	Incoming solar energy for a typical apartment that influences the cooling demand.(MJ)	Average total energy demand per typical apartment (MJ)
AMSTERDAM WWR=0,54							
opaque surface	24	429,7	32,6	10.313	782,4		
transparent surface	13	565,4	42,9	7.350	557,7		10.404
total				17.663	1.340	1.806	

ATHENS EXISTING CONSTRUCTION CHARACTERISTICS AND CURRENT ENERGY PERFORMANCE.

The opaque part of the wall of the building in Athens consists of clay bricks and plaster with $U\text{-value} = 1.48 \text{ W}/(\text{m}^2\text{K})$.

U-Value calculation according to DIN EN ISO 6946

#	Material	Dicke [cm]	λ [W/mK]	R [m ² K/W]
	Thermal contact resistance inside (R _{si})			0,130
1	HASIT 182 Filzleichtputz	1,00	0,250	0,040
2	Clay bricks 1500kg/m ³	9,00	0,660	0,136
3	Stationary air (unventilated)	2,00	0,114	0,175
4	Clay bricks 1500kg/m ³	9,00	0,660	0,136
5	Cement plaster	2,50	1,400	0,018
	Thermal contact resistance outside (R _{se})			0,040

Thermal contact resistances have been taken from DIN 6946 Table 7.

R_{si}: heat flow direction horizontally

R_{se}: heat flow direction horizontally, outside: Direct contact to outside air

Thermal transfer resistances of resting air layers were calculated as follows:

Layer 3: Thickness 2 cm, Width ∞ , DIN EN ISO 6946 Table 8, heat flow direction horizontally

Thermal resistance $R_{\text{tot}} = 0,6756 \text{ m}^2\text{K}/\text{W}$

Heat transfer coefficient $U = 1/R_{\text{tot}} = 1,48 \text{ W}/(\text{m}^2\text{K})$

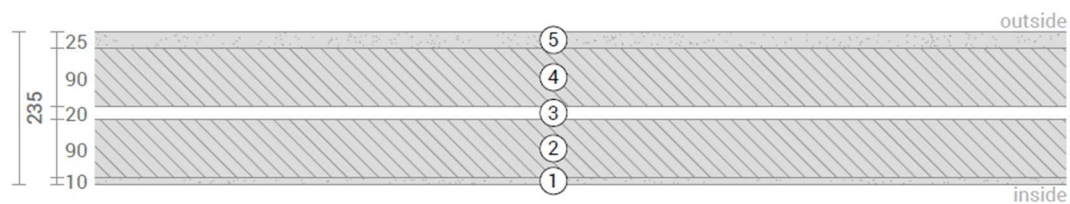

Figure 47, existing wall construction

The transparent part of the facade that is used in the existing construction consists of single glazing windows with $U\text{-value} = 5.7 \text{ W}/(\text{m}^2\text{K})$

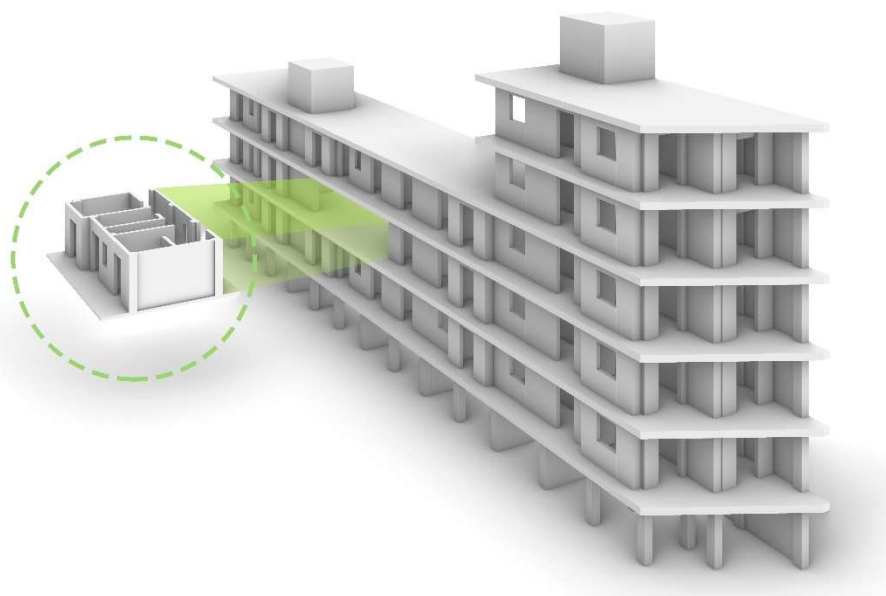

Figure 48, Selection of one typical apartment as a representative example of the building.

The same process has been followed for the case study in Athens. According to the climate consultant software the average solar irradiation during the cooling season which in this case is from June to September and the **qsun=470 W/m2 per hour**. The windows are around 646 hours to the direct sunlight during the cooling season.

According to the sun-hours analysis, all the window area of the apartment is exposed to the sun. Thus, the g value in this case will keep the standard g-value as there is no shading. A single glazing window has g-value=0,8.

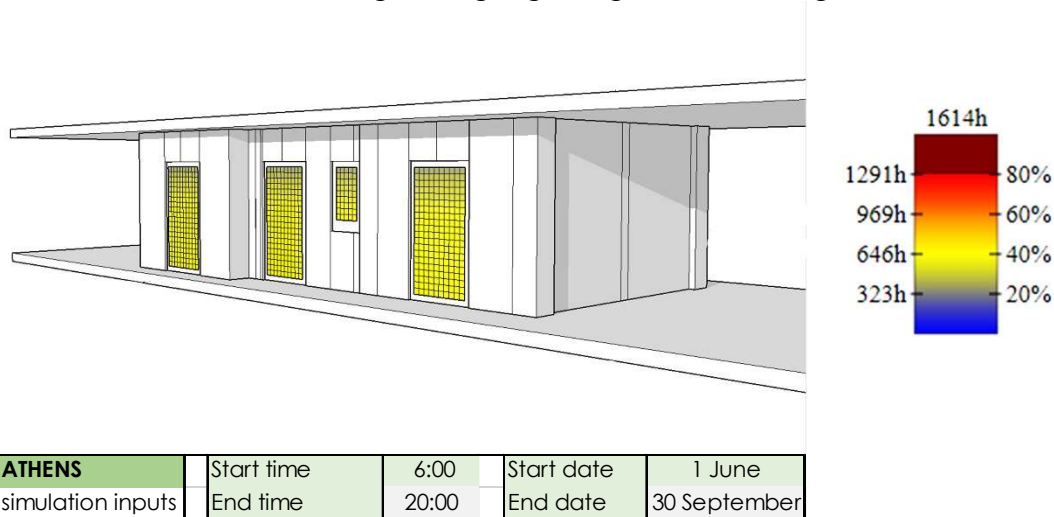

Figure 49, Sun-hours analysis of a typical apartment in building in Athens in the East façade.

As it is presented in the table 13, the current energy demand per typical apartment in the building of Athens for the heating season is 11.829 MJ and 19.675 MJ during the cooling season with an Average demand per apartment 15.752 MJ.

Table 13, Current energy demand due to heat transmission and solar energy

Energy performance of the existing façade for a typical apartment	total surface area of a typical apartment (m2)	Heat transmissions per square meter during the heating season. (MJ)	Heat transmissions per square meter during the cooling season. (MJ)	Current energy demand for heating of a typical apartment due to the heat transmissions.(MJ)	Current energy demand for cooling of a typical apartment due to the heat transmissions.(MJ)	Incoming solar energy for a typical apartment that influences the cooling demand.(MJ)	Average total energy demand per typical apartment (MJ)
ATHENS WWR=0,38							
opaque surface	31,7	149,6	149,3	4,742	4,732		
transparent surface	12,3	576,2	575,2	7,087	7,074		15,752
total				11,829	11,806	7,869	

8. Design application

In this chapter, the façade renovation system for energy reduction will be applied to the two case study buildings, in order to show the process and the tools that can be used to select the appropriate combination of the façade elements through different design decisions.

At the first stage of the process, the different functions of the building envelope need to be analyzed in order to define the different types of the facade system modules that will be applied on each surface of the existing building envelope. The facade system will incorporate different kinds of modules based on different design and energy reduction principles that will be related to the function of the different facade areas, the characteristics of the building and the orientation.

At the second stage, the design of the different approaches will take place by developing each variation of the facade module separately. During the design process, different tools and methods will take place according to the formulated principles of the "Generic design". The final result of each module variation will be a combination of decisions based on energy reduction and functionality.

In the next step, the different variations of modules will be designed in detail in crucial points of the building, in order to depict the adjustability of the system which consists of different types of modules, while at the same time shows how the whole facade system for energy reduction renovation can overcome a series of different challenges that could face or what are the modifications that could be made in order to have the most optimal solution.

The impact of the energy reduction after the application of the façade system will be illustrated by calculating the energy savings in percentage, based on the U-values of the opaque and the transparent area of the building before and after the installation of the facade system. The impact from the solar heat gain will take into account for the calculation for the cooling season while the generated power from the PV panels will also be included in the final result of the energy reduction. To estimate the energy reduction after the application of the façade system, the same typical apartment will be selected that has been already analyzed in chapter 7.

8.1 Variations of the façade system in the building in Amsterdam

Design approach

In order to approach the facade renovation system of the building in Amsterdam, three different indicators have been selected to render the variations of the facade system. The first parameter is related to the function of the building that will be covered with the new facade modules, the second is related to the orientation and the location and the third with the energy reduction of the building. In figure 50, a simulation has been made based on the orientation of the building during the whole year to estimate which side of the building affected more by the sun. This simulation will help to decide the energy reduction characteristics that the façade modules will incorporate.

There are four types of modules that have been developed for this facade system and they are illustrated in Figure 51. The development of these four modular types have been formulated in order to cover the different needs of the building envelope and increase the energy performance.

The functions of the building envelop are three:

1. Common external hallway on sides (1), (3), (4)
2. Private balconies on side (2)
3. Vertical common circulation on sides (2) and (4)

These functions combined with the orientation create different types of modules.

The first type of facade module has integrated PV panels and small windows and has been developed in order to be installed in specific points of the existing building envelope. These points are where is enough direct sunlight for electricity generation and no need for a lot of sunlight for the dwellings.

Therefore, the façade module type (1), according to the simulation and the functions of the building will be applied on the side (1) where more than 80% of the year is exposed to direct sunlight and there are no openings for the dwellings. In addition, the same module type is also suitable to be installed on sides (2) and (4) where the direct solar irradiation is around 60% during the year. In contrast to side (1), sides (2), and (4) are the only source for natural lighting to the apartments this means that these sides cannot be covered with this module type as it will reduce the natural light dramatically. However, there are some areas on both sides that can be exploited and install this module type. These areas are where the circulation is located, as is showed in figure 51.

The sides (2) and (4) will be covered with two module types. On the side (2), Type (1) will be applied to the surface of the vertical circulation as in this position there is no need for large openings due to the location of the common staircases, while the module type (4) will be applied in front of the dwellings for maximum natural light and adjustable shading with the use of external aluminum roller blinds. As far as the side (4) is concerned the same will be followed with difference that the modules in front of the dwelling will incorporate fixed louvers instead of roller blinds.

The distinction between the two different shading systems stems from the different functions of the building in the two facades. The selection of blinds on the side where the private balconies are located has been made in order to give the opportunity to the residents to choose the level of sunlight in their apartment. On the other hand, the fixed louvers have been selected for side (4) as this area is a common space and there is no need for further adjustment.

Lastly, on the building side (3), facade modules with the maximum transparent surface will be applied without a shading system or PV panels as there is not enough direct sunlight for energy generation or need for shading. Nevertheless, optical connection with the external environment and the ambient light is important for the adequate lighting of the building.

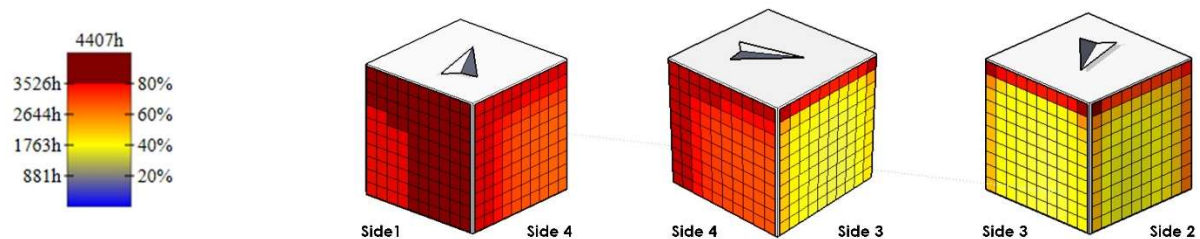

Figure 50, Sun-hours analysis in cubic meter specimen, based on the climate of Amsterdam and the building orientation for the whole year.

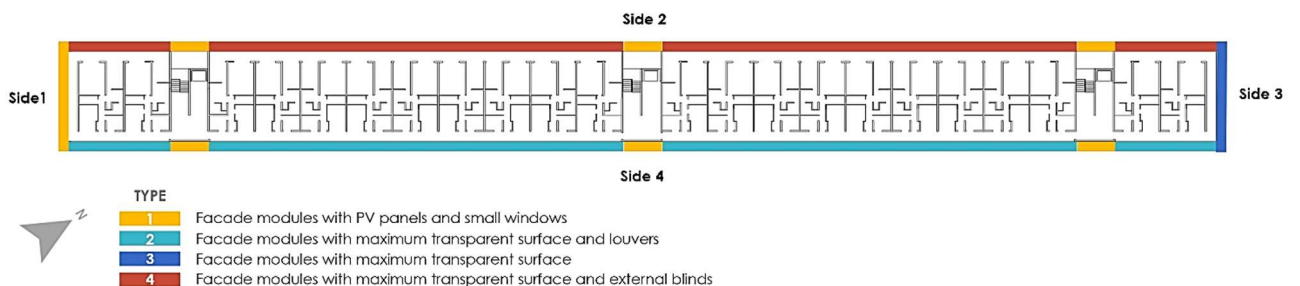

Figure 51, position of the different types of modules for the facade system for energy reduction renovation.

Attachment approach

Regarding the attachment of the system to the existing building, two different approaches will be used. The first approach has to do with the application of the facade system on a balcony. Therefore, the third option from the variants

of the "Generic design" will be used which shows the method that needs to be followed in order to attach the façade system in balcony. The second attachment approach takes place where the vertical circulation is located. In this area the building envelope consists of a concrete flat external wall. Therefore, the first option from the "Generic design" options will be used as it explains the technics in order to attach the façade modules on a concrete wall.

Energy reduction approach

After the determination of the design requirements, the energy reduction principles need to be included in the final facade system. The principles that will be followed to define the energy reduction measures will be based on the selection of the appropriate energy reduction elements and the energy tools that have been formulated in the "energy reduction principles" section of Chapter 6.

The aim is to select the most efficient combination of energy reduction elements, in order to reduce the current energy demand of the building while keeping the new facade system as simple as possible. The tools that will be used to achieve the energy reduction are hand calculations, the online tool "Ubakus" for the energy transmission losses, the simulations with the Passive design assistant (PDA), the Sun-hours plug-in to determine the most suitable result of shading and the PVGIS online tool of the "European Commission" will be used to estimate the energy production from the PV panels.

Design process.

To begin with, the design process will start by focusing on every side of the building separately in order to clarify the design process of each façade according to the building characteristics, the orientation and the function. The process starts by analyzing the side (1) and the application of the module type (1) and consists of three design stages.

SIDE 1

Stage 1: Firstly, it is necessary to define the positions of the supports for the façade modules according to the "generic Design" principles. The aim was to divide the facade in such a way so that the modules would have the same width and height in order to render the production process of the facade panels easier. The dimension of the module cannot exceed the length of 6 meters for reasons that have been identified in the generic design and are related to the ease of construction and installation of the façade panels. Therefore, the modules have been formed with dimensions of 5.55 by 2.8 meters' height.

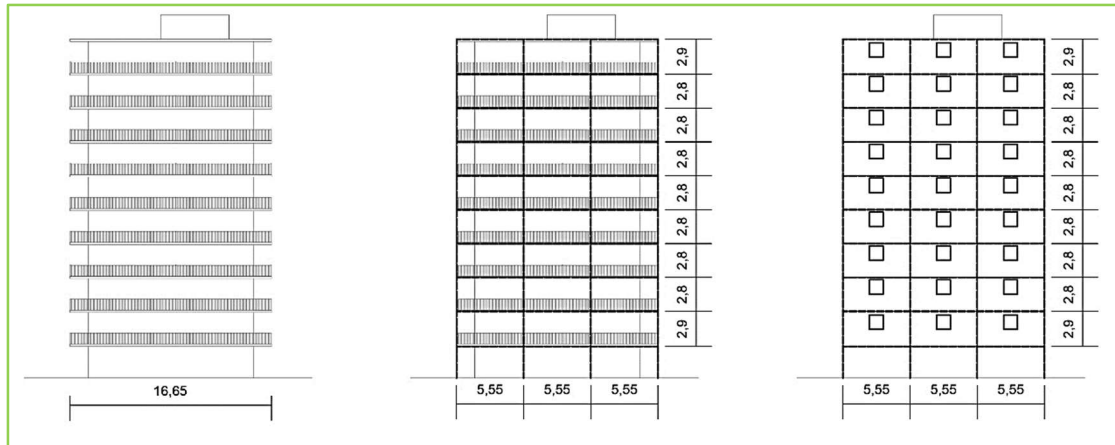

Figure 52, Determination of the grid for the support system and the façade system modules on side (1).

Stage 2: At this stage the window wall ratio is defined in order to get the maximum surface for the PV panels while keeping some transparent surface for natural lighting. The final dimensions of small window determined by the dimensions of the PV panels. As the goal was to have as many PVs as possible in every module.

The tolerances between the modules are 4 and 8 cm depending on the side of the module. The vertical sides of each module have 4 cm tolerance from the metal hook that support the modules while on the top and bottom side of the modules the tolerance is 2 cm in order to reduce the gaps the mineral wool will need to cover. The use of bigger tolerance in the vertical sides is due to the need for easier access to the metal connectors during the installation process.

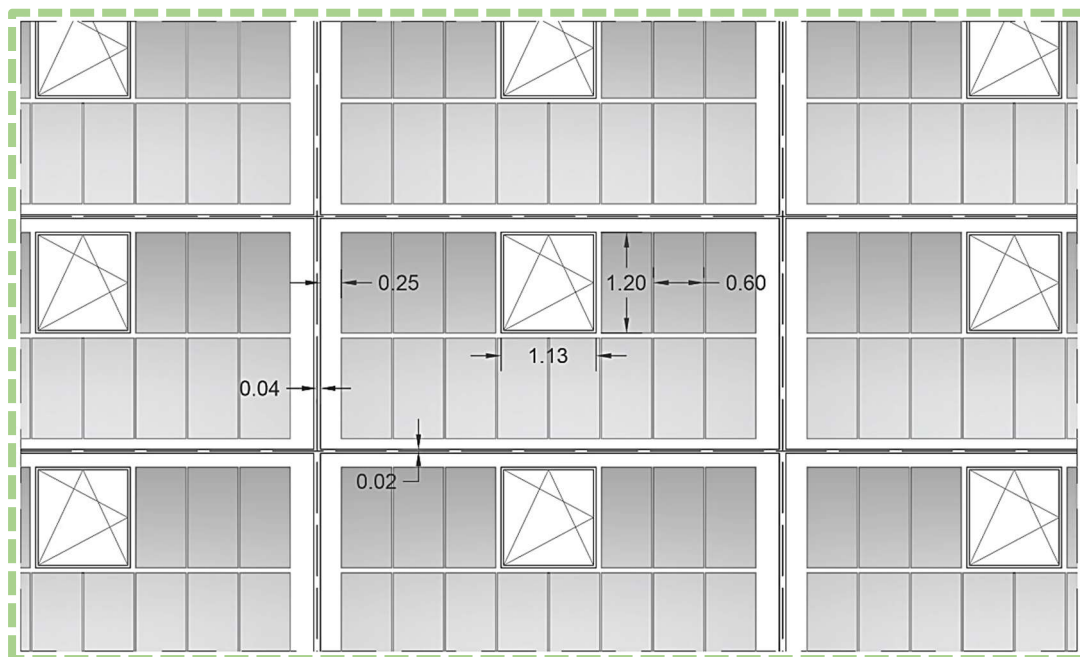

Figure 53, part of the façade system on side (1), modular type (1)

Stage 3: At the third stage, the aim is to define the electricity that can be produced from each façade module due to the 14 integrated PV panels. For this purpose, the online tool PVGIS of the “European Commission” was used and a table with the average [kWh/PV] has created to define the energy production of the PV for each side of the building. According to the table 14, a PV panel on the side (1) can produce 7.7 Kwh per month which means that every façade module can produce approximately 108 kWh per month. As a result, the whole new façade can produce around 35.000 kWh of electricity annually.

Table 14, Electricity Production of a PV panel according to the building side.

Month	SIDE 1	SIDE 2	SIDE 4
	Monthly electricity production (kWh)/PV	Monthly electricity production (kWh)/PV	Monthly electricity production (kWh)/PV
January	3,2	0,7	4,6
February	4,2	1,1	5,4
March	8,4	2,5	9,6
April	11,2	4,4	11,9
May	11	5,8	11
June	11,3	6,8	10,1
July	11,3	6,4	10,4
August	10,4	4,9	10,5
September	8,7	2,9	9,9
October	6,3	1,5	7,8
November	3,5	0,7	5
December	2,6	0,5	4
Average	7,7	3,2	8,4

SIDE 2 and 4

Stage 1:

A similar process of defining the position of the vertical supports has been followed as on the side (1) of the building. The same design principles will be followed for both sides (2) and (4) as they have the same building envelope characteristics. Therefore, in the facade area where the vertical circulation is located, the module type (1) will be applied while in the rest facade the module type (2) and (4) will be installed accordingly.

Even though that the two sides have the same façade characteristics there is a functional difference that makes the shading system on both sides follow different approaches. On building side (2), externally adjustable roller blinds will be integrated in the modules to give the opportunity to the users to adjust the percentage of shading according to their needs. Additionally, after the application of the new façade the occupants have the option to expand their

apartments and use the balcony area as interior floor space or keep the existing function of the balcony.

Regarding the side (4), the same facade units will be made in terms of window-wall ratio, with the difference that on this side fixed aluminum louvers will be integrated into the facade modules for sun shading.

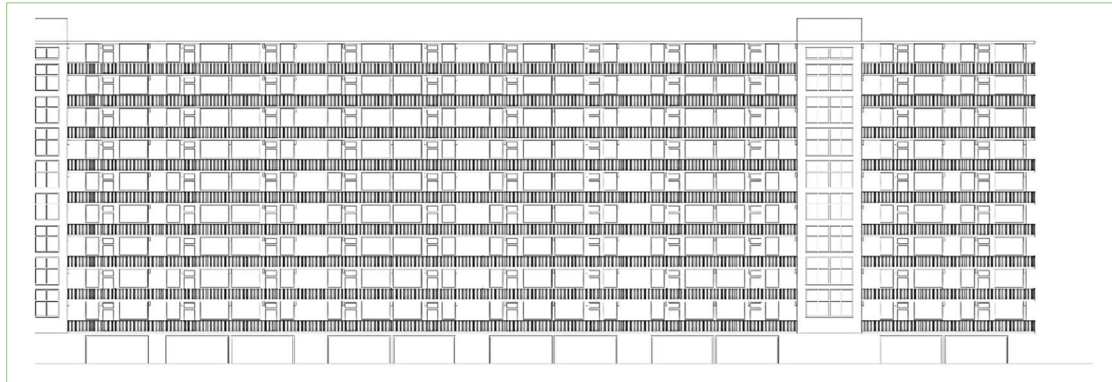

Figure 54, Current situation of the façade of the building in Amsterdam.

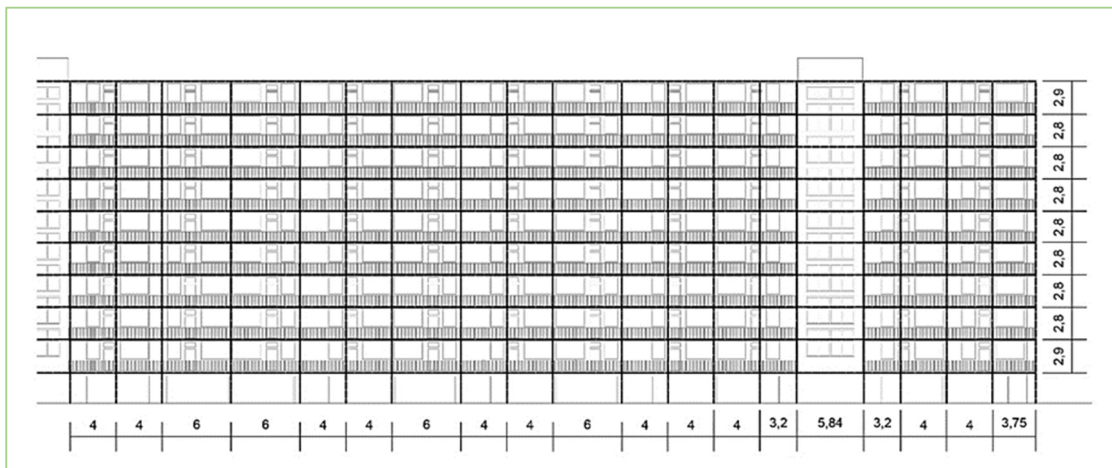

Figure 55, Determination of the grid for the support system and the façade system modules.

Stage 2:

At the second stage, the window-wall ratio of the façade modules of the renovation system is defined for the two facades of the building. The façade module type (1) will be installed in the part of the building where the vertical circulation is located which can integrate 13 PV panels for electricity production. Additionally, a small transparent window area which is one-third of the existing window surface, will stay the same for lighting and air-ventilation purposes of the internal space of the staircases.

As far as the modular type (2) and (4) is concerned, the aim is to have as much as a possible transparent surface area for natural lighting to the interior of the dwellings. However, external shading system with blinds or louvers is

necessary to avoid overheating during the cooling season and reduce the g value of the glass surface area.

Even though the need for shading is necessary, there are some limitations as far as the structural part of the panel and the connection between the panel and the existing building. The facade modules need a minimum space at the perimeter of each panel to create a stiff structure in order to support the functions that are necessary. With this as a given, the sides of the module need to have enough strength and space to support the weight of the aluminum windows, the shading system, or the PV panels, while at the same time supporting the metal hinges that are necessary for the attachment of the modules to the existing facade.

Despite the fact that there is need of big transparent areas for natural lighting the glass does not perform very well in terms of heat transition as much as an opaque wall. Therefore, the bottom part of the modules consists of a wider opaque surface area in comparison with the other three sides of each module to increase the percentage of the opaque part without dramatically obstructing natural light and the view of the outside environment. The reason was decided to increase the opaque surface of the modules was due to the need for better insulation as the building is located in a country that belongs in the category of cold climates where the need for heating is extensive and the glass surfaces cannot contribute as efficiently as the insulated walls.

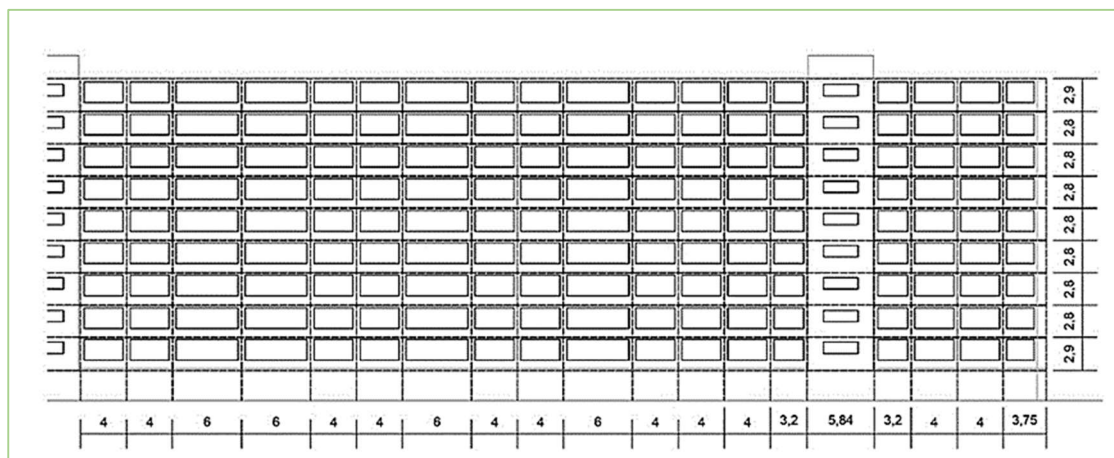
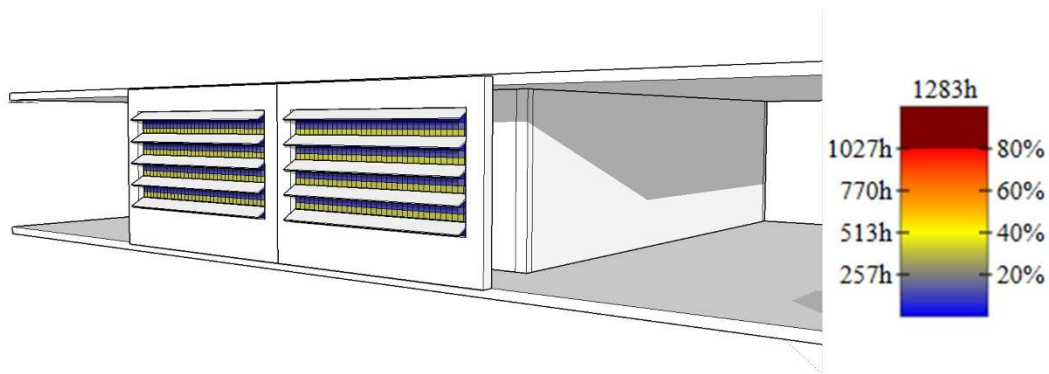

Figure 56, Determination of the final areas of the transparent and opaque part of the modules.

Stage 3: To determine the most suitable option for the shading system, the PDA software was used. Even though that this software can show the best solution in terms of shading by indicating the temperature reduction on a characteristic day in the interior space of a room, it is not possible to take into account other parameters such as visual connection with the environment. For this reason, a simple 3D model of a typical apartment was designed in Sketch-Up to evaluate the parameter of the visual connection of the most optimal shading solution from the PDA, while at the same time the Sun-hour Plug-in was used to check the direct sunlight that reaches the glass area of the module and the percentage of reduction of the g value of the glass.



AMSTREDAM simulation inputs	Start time	6:00	Start date	1 June
	End time	20:00	End date	30 August

Figure 52, Sun-hours analysis with the façade modules with louvers on a typical apartment.

After different variations to define the most optimal solution for the louvers, it was concluded that the best combination of parameters for the facade modules on the side (4) is to incorporate aluminum horizontal louvers of 300mm width and 400mm spacing between them at an angle of 30°. The horizontal direction of the louvers was selected due to the fact that creates less visual distraction in the outdoor environment in comparison with the vertical louvers, as the horizontal direction of the louvers follows the movement of the occupants when they use the external common hallway. At the same time, the spacing and the width of the shading system allow around one-third of the window surface exposed to direct sunlight with immediate effect the reduction of the g-value of the glass, while keeping the connection of the occupants with the view.

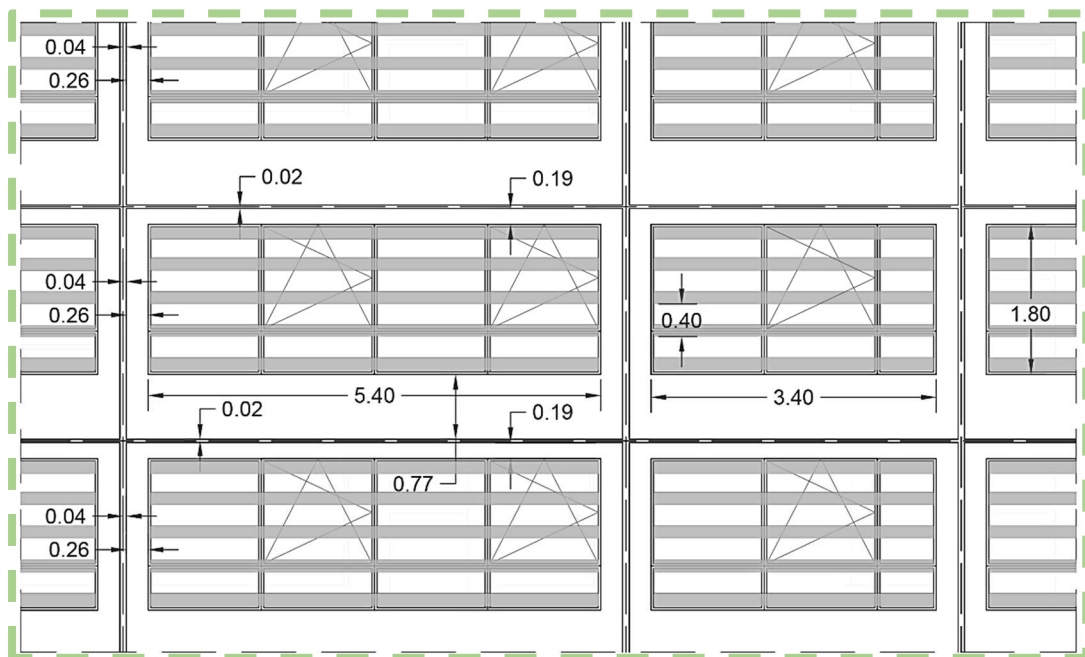

Figure 53, part of the façade system on side (4,) modular type (2)

Regarding the façade modules on the side (2) with the integrated external roller blinds, the average reduction of the g value due to the shading is similar

to the one on the side (4) with the louvers. This factor will take into consideration in the calculations of the heat transitions, as the same values will take into account for both sides of the typical apartment.

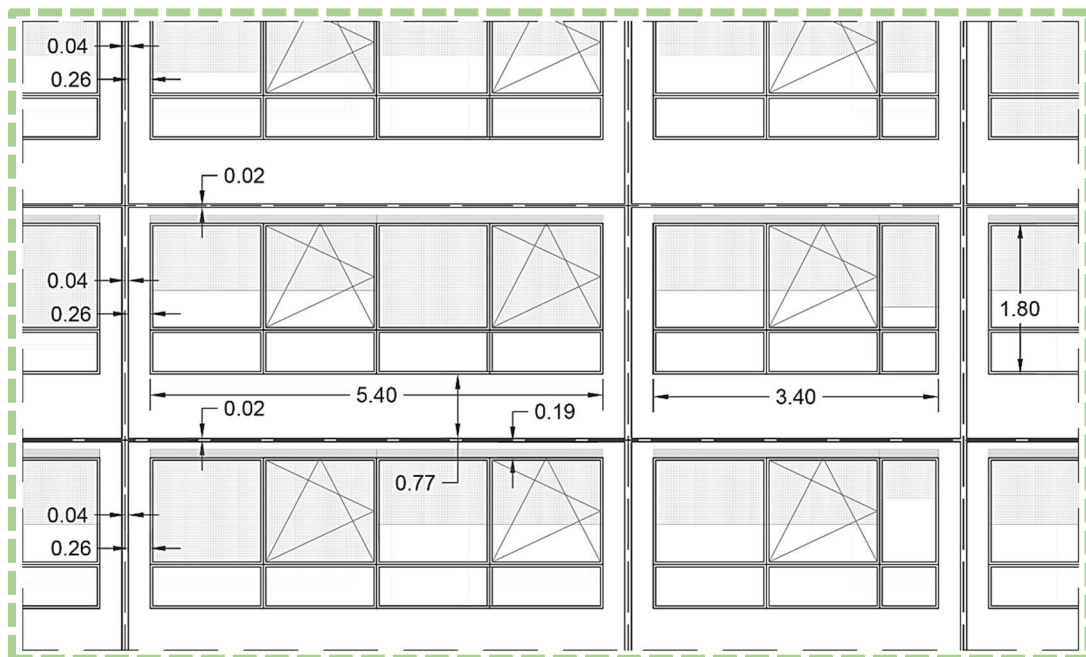

Figure 54, part of the façade system on side (2) modular type (4).

As far as the facade module type (1) that will be installed on the existing building surfaces where the common staircases are located the electricity output needs to be calculated according to the values of table 14. For the building side (2) the PV can produce 3.2 kWh per month. Thus the facade modules on the side (2) can produce 4.500 kWh annually.

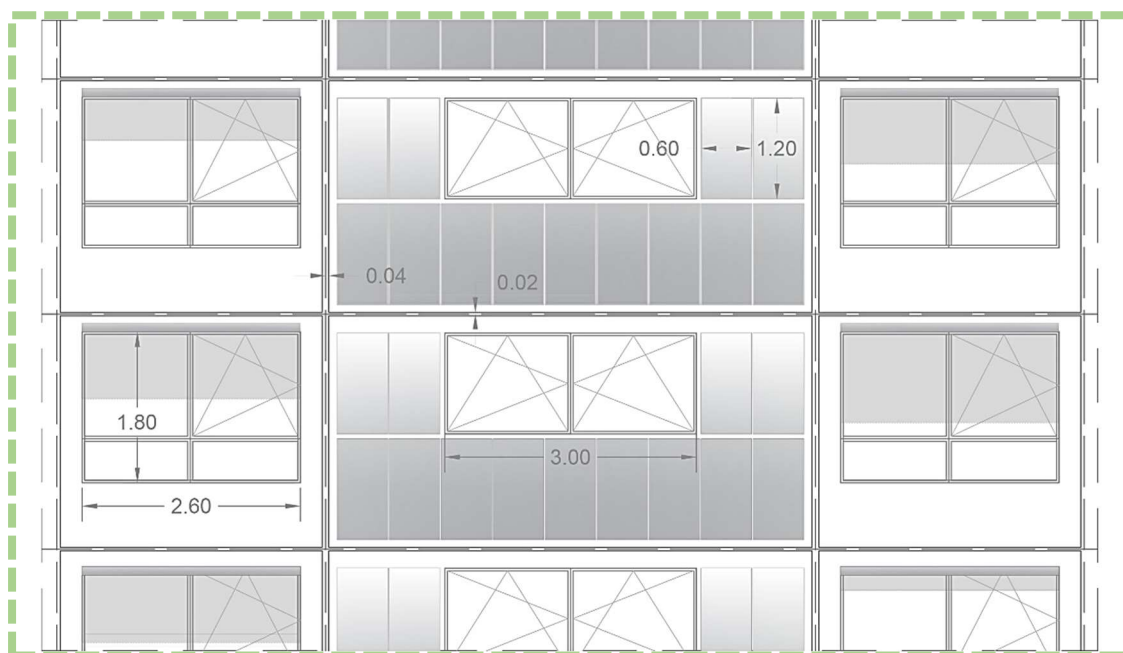

Figure 55, part of the façade system on side (2) modular type (1) and (4).

At the same time, the facade modules with the integrated PVs on the side (4) can produce 11.800 kWh per year as the orientation of that side of the building is exposed more hours to the solar irradiation.

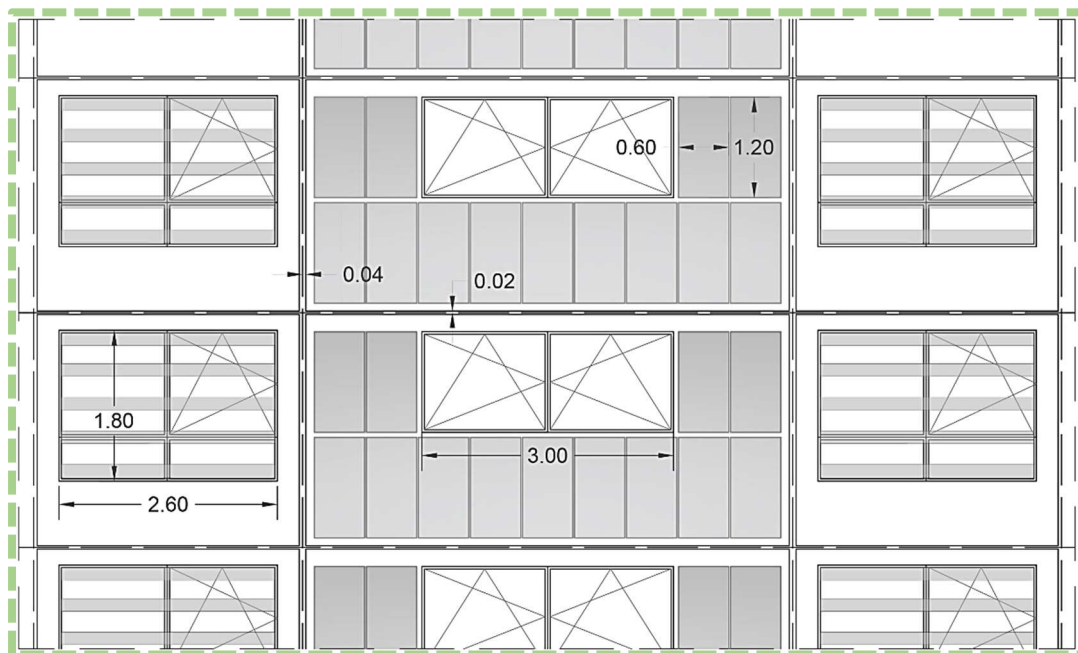

Figure 56, part of the façade system on side (4), modular type (1) and (2)

SIDE 3

At the side (3) of the building, there are no sun shading systems nor PV panels due to the fact that there is no need for shading as there are no openings in the existing surface of the building and the orientation is not preferable for PV panels due to the low solar irradiation.

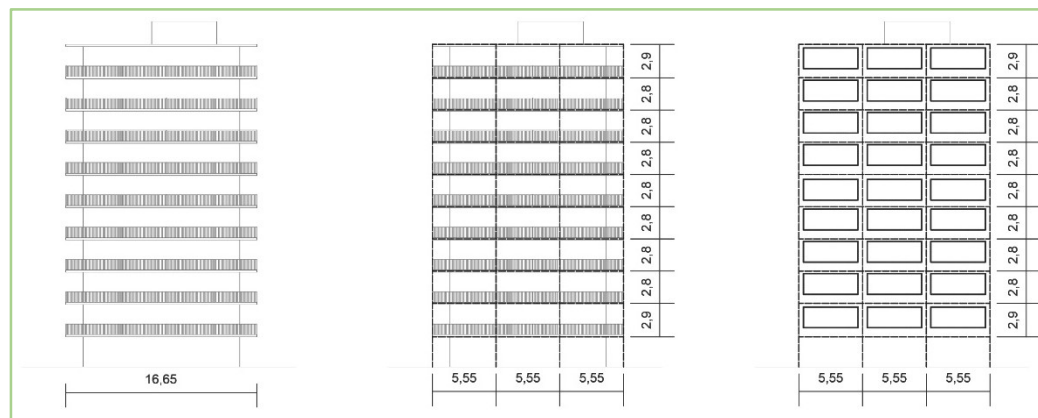

Figure 57, Determination of the grid for the support system and the façade system modules on side (3).

Nevertheless, the maximum transparent surface is needed for this side of the building in order to let the daily light pass on the internal side of the building.

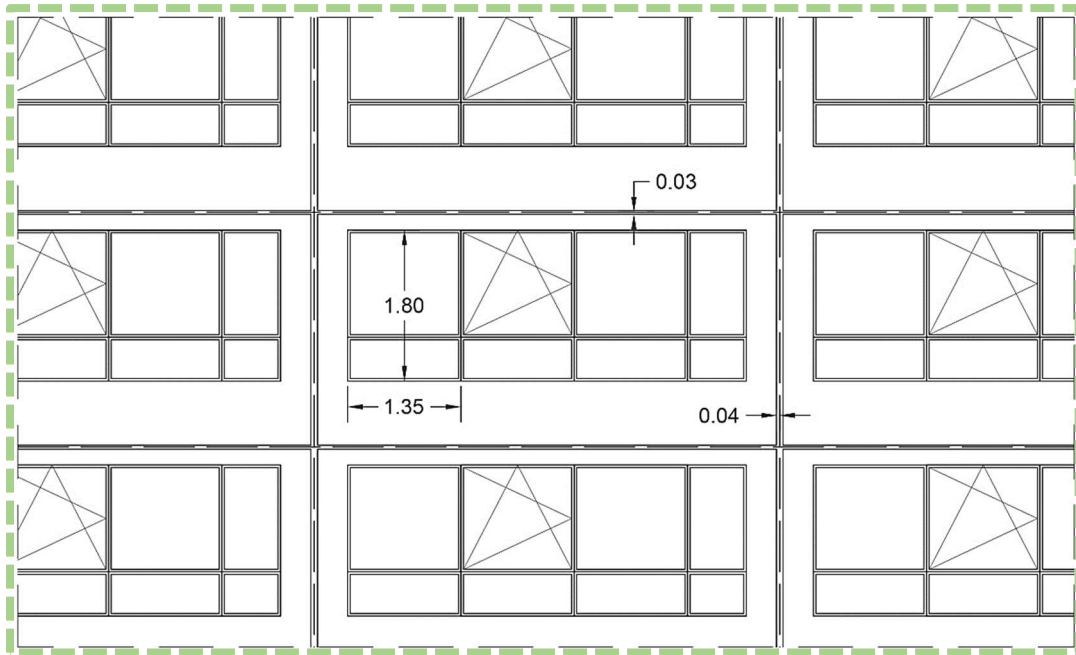

Figure 58, part of the façade system on side (3), modular type (3)

Critical points of the façade renovation system

In order to present the adaptability of the system in different situations, three critical points are presented in detail. The first detail is in the connection between the two different module types where the module type (1) which is attached on a concrete wall meets the module type (2) which covers the balcony area and is attached to the vertical support system.

As the figure 59 illustrates, the module type (1) is attached with two different attachment approaches. The one side of the module which is located on the edge of the concrete wall is connected with the vertical timber support while on the other side of the module the connection with the existing building envelope is achieved with the use of a metal hook.

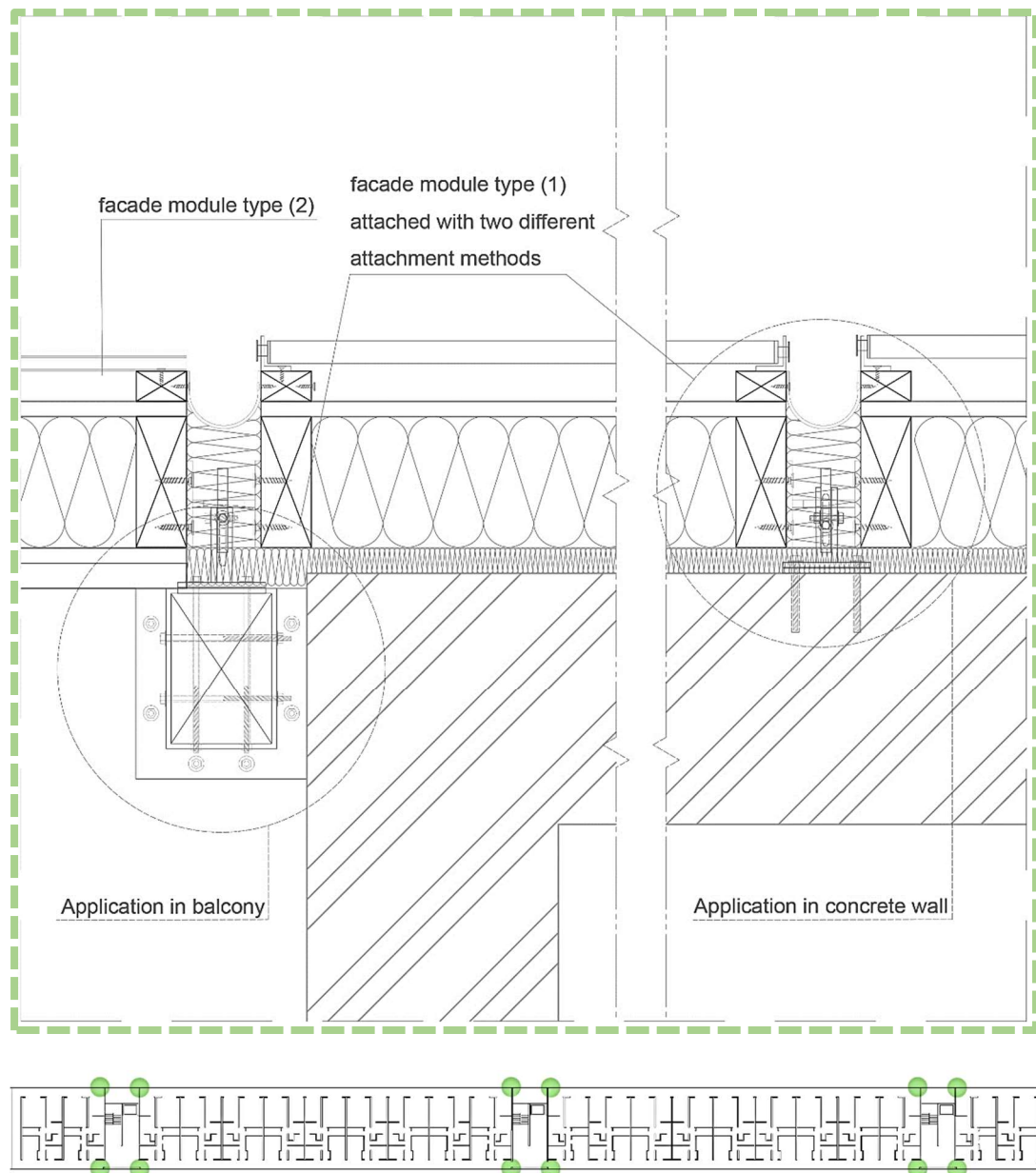

Figure 59, Detail in top view between different façade module types and building envelop characteristics. The green dot indicates the position of the detail.

The second crucial point that is presented, is where the vertical facade modules meet the top of the building. In this case, in order to avoid thermal bridges, simple roof modules are constructed with the same design principles as the vertical ones with an extra function. This extra function is the air gap that is created between the external inclined aluminum surface and the insulation to avoid water condensation. The roof of the building is covered with EPS material for insulation and waterproof membrane for roof applications in order to protect the top apartments from thermal bridging on the roof. The application of the vertical mineral wool in the internal part of the concrete element and the EPS insulation boards of the ceiling is an extra on-site procedure that is not included in the system. However, it is necessary for the continuous protection of the building from the phenomenon of thermal bridging.

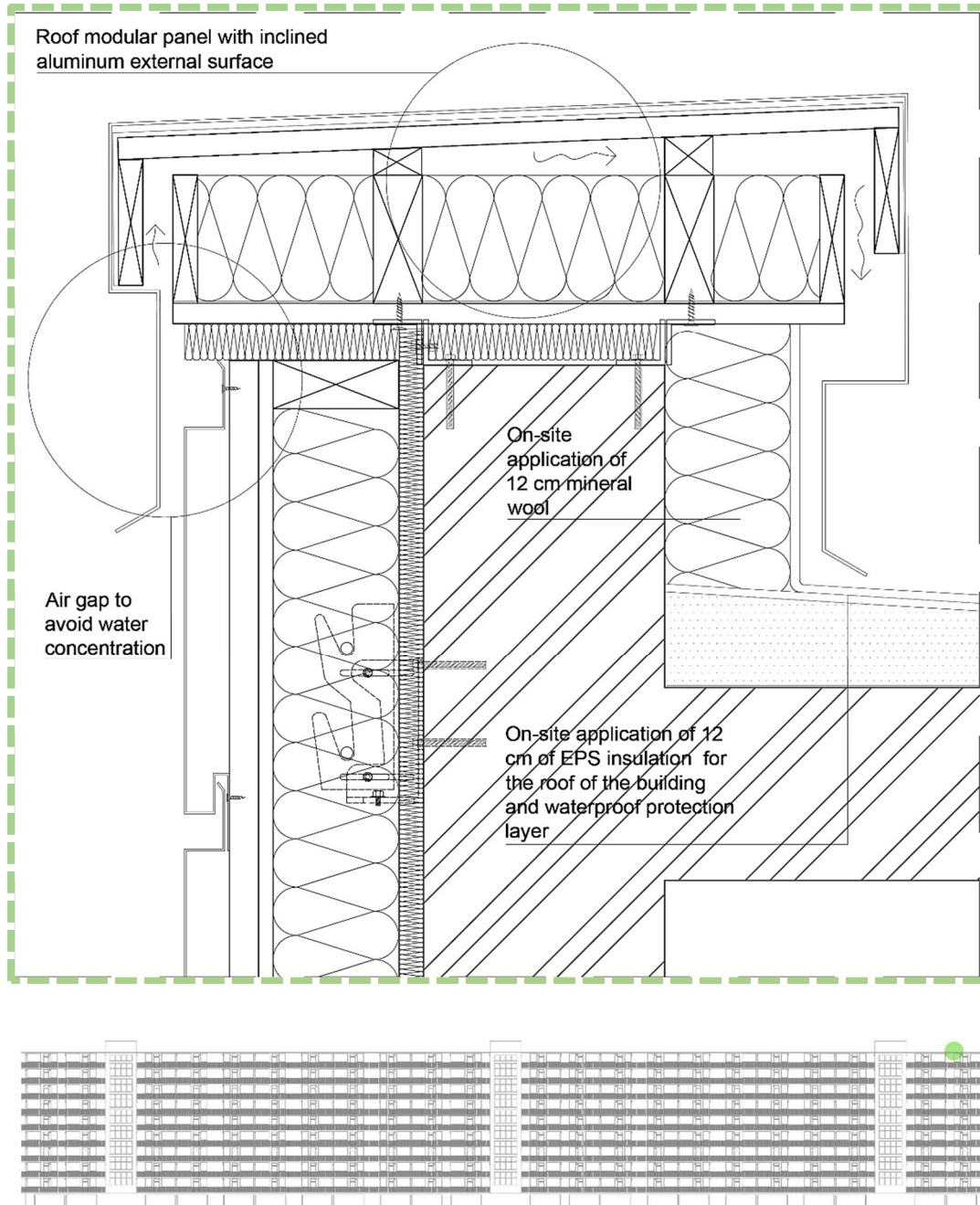

Figure 60, Detail in section between a façade module and the roof. The green dot indicates the position of the detail.

The third crucial point that will be illustrated in detail is on the corner of the building where two module types are connected at a 90-degree angle on the corner of the building. The drawing in figure 61 illustrates the corner where the building side (1) meets the side (4). At this point, one module covers the other module, with the aim to create smaller gaps that will be filled with mineral wool insulation to avoid thermal bridging.

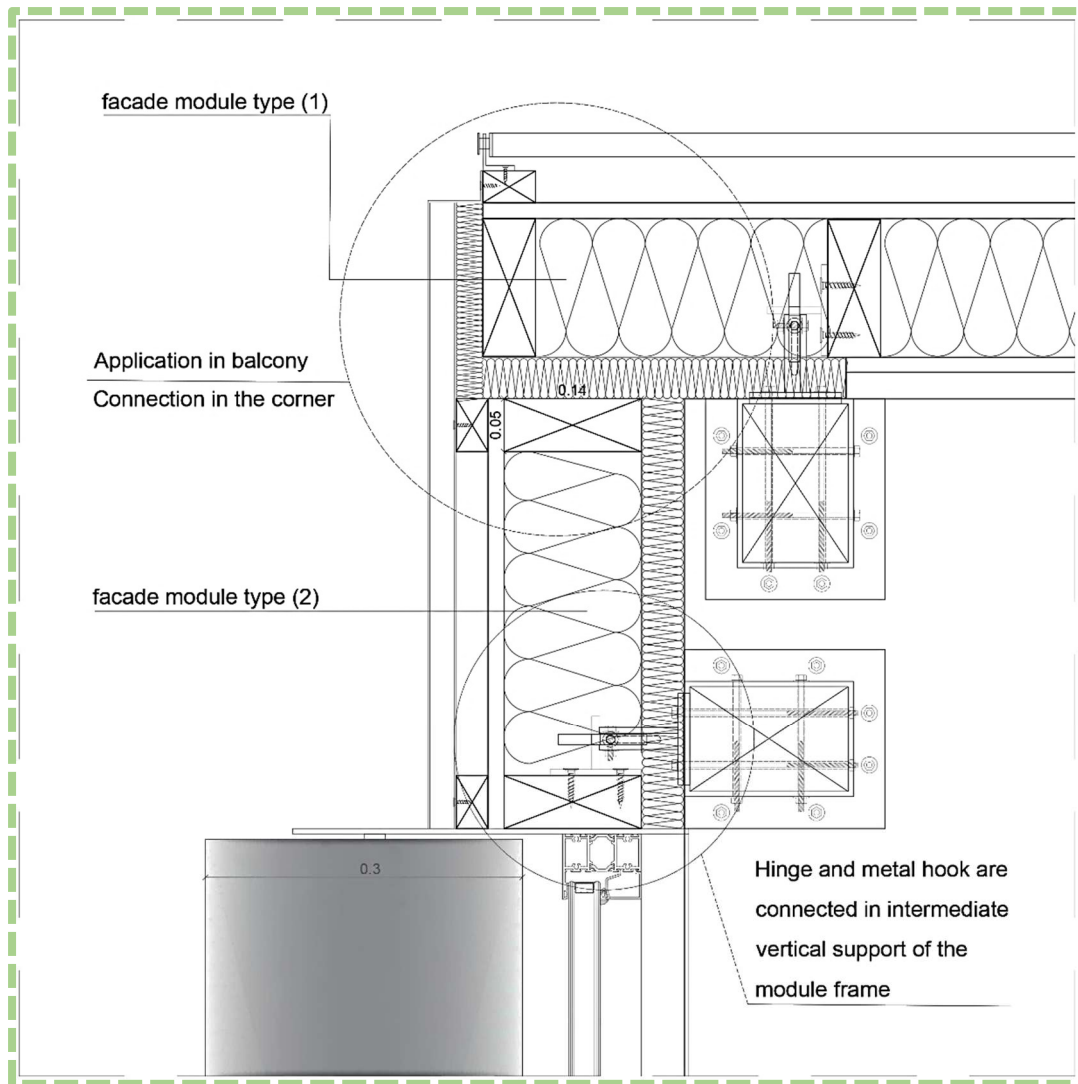

Figure 62(a), Detail in top view between two modules on the corners of the building.

In cases where there is a connection between modules at an 90 degree angle in a balcony, the installation of the corner module in the existing surface could need to be modified. In contrast to the standard way of installation of the modules with the use of metallic hinges from the vertical sides of the facade modules, in the case of a corner, the position of the metal hinge is located in one of the internal vertical supports of the module frame while the timber supports are installed accordingly. As is illustrated in figures 62a and b.

Additionally, when space is needed in order for one module to cover the other, further adjustment has to take into account during the design process to make the corner modules with extra cladding material or adjust the spacing around the modules accordingly.

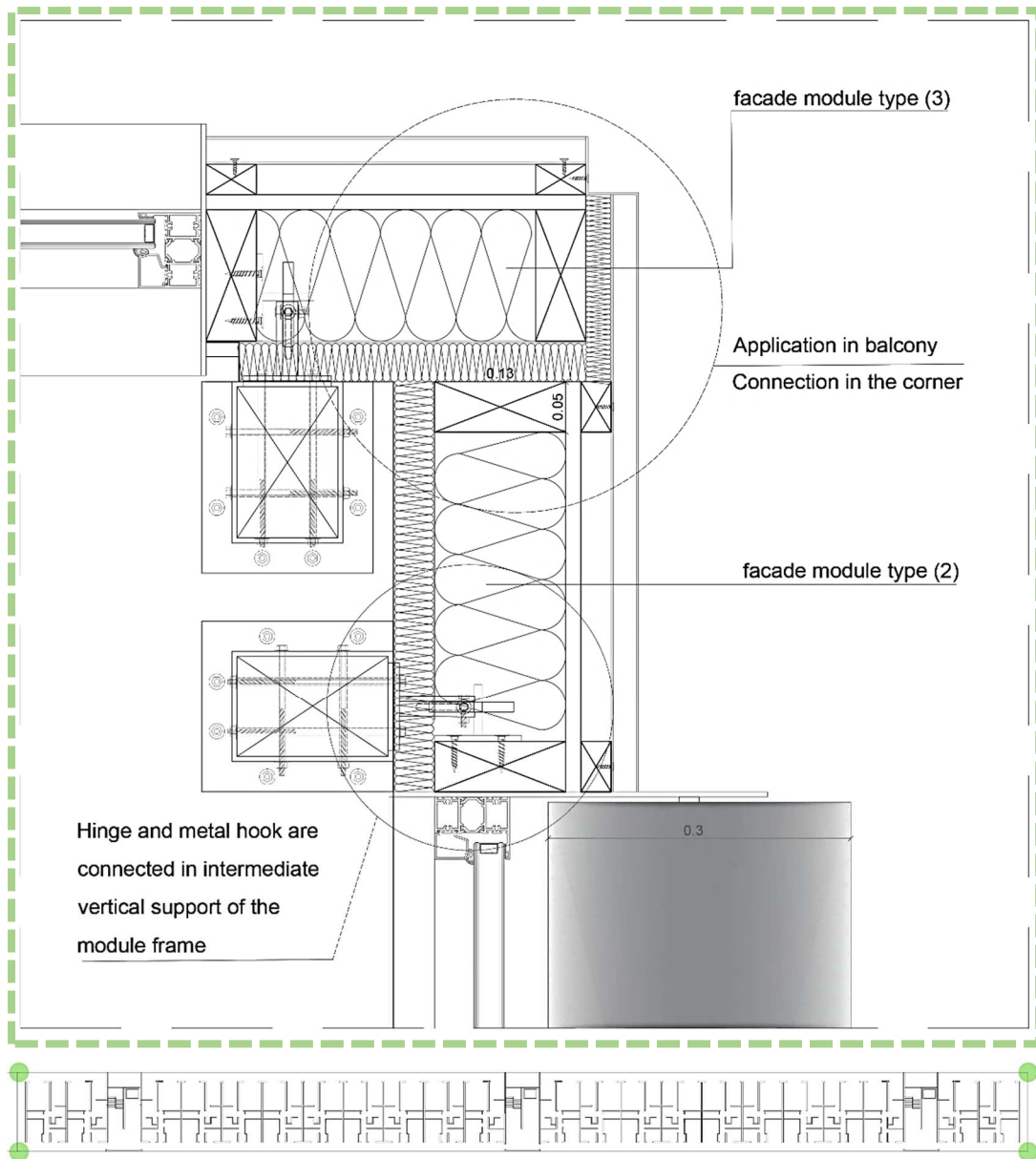

Figure 62(b), Detail in top view between two modules on the corners of the building. The green dot indicates the position of the detail.

Energy reduction Principles

In order to define the impact of the installation of the facade system on the energy demand of the building in Amsterdam, a typical apartment has been chosen to be analyzed according to the principles that have been formulated in the "Generic Design" section. The goal of energy reduction is to achieve energy savings of at least 50% relative to the current energy consumption of the building. Apart from the energy-reduction goal, the aim is also to check how the system performs according to the selection of the energy reduction elements in the previous stages.

In order to get the final result of the energy reduction, the overall new U-value of the new façade system has been used to indicate the energy reduction

after the application of the system. In order to define the u-value of the opaque part of the new system, the online tool "Ubakus" was used.

The selection of the energy reduction elements has been made based on the principles that have been formulated in the energy reduction principles section in Chapter 6. The aim was not only to achieve a reduction of energy consumption but also to create a façade system as lightweight as possible. The lightweight modules contribute also to a smoother production process and in easier installation, since the heavy panels according to research on pilot projects create problems during the deferent phases of the renovation.

Two different construction variations for the opaque part of the system have been calculated. The one has 8cm insulation and U-value =0.43 W/(m²K) and second one has 14 cm insulation and U-value =0.27 W/(m²K). The first option as it is depicted in table 15, gives a total energy savings of 68% while the second option as it is showed in table 16, gives a total energy savings of 70%.

Even though that there is a very small difference in the energy savings there is a big difference in terms of structural stability. In the first case, the thickness of the insulation is 8 cm and according to the "Generic design" principles, the thickness of the insulation affects also the thickness of the module. This means that the thickness of the main structural frame will be 8 cm a fact that might create stability problems when all the energy reduction elements such as windows and aluminum louvers will be integrated into the modules due to the fact the selected louvers are 30cm wide. Therefore, it is decided to use the thicker version of the module, in order to have bigger module frames which means stronger construction.

The choice between the two thicknesses is possible due to the maximum size of the frames which in most cases does not exceed the 4 meters' width. By keeping the units relatively small, we can make small adjustments to the thickness of the module according to the needs without extreme changes in their weight.

In figure 63 are depicted the energy reduction elements that have been selected for the opaque surface area of the facade system. These elements are selected from the energy reduction lists that have been formulated in the "Generic Design" section.

Regarding the U-value of the transparent part of the system, a window with double glazing and Low-E has been selected with $U = 1.3 \text{ W} / (\text{m}^2 \text{ K})$ and g-value = 0,2 after the application of the shading system. The reduction in the g value of the glass achieved due to the shading simulations that have been made in the previous stages. The selection of the double glazing window with Low-E has been selected as this combination can create a very efficient energy reduction result for the transparent surface of the system, while at the same time keeps the weight of the module relatively low if we compare it with a triple glazing window.

U-Value calculation according to DIN EN ISO 6946

#	Material	Dicke [cm]	λ [W/mK]	R [m ² K/W]
	Thermal contact resistance inside (Rsi)			0,130
1	Gypsum board	0,95	0,250	0,038
2	Vapor retarder sd=2,3m	0,05	0,220	0,002
3	ROCKWOOL Klemmrock 035	14,00	0,035	4,000
	Spruce (7,7%)	14,00	0,130	1,077
4	Gypsum board	1,25	0,250	0,050
	Thermal contact resistance outside (Rse)			0,130

Thermal contact resistances have been taken from DIN 6946 Table 7.

Rsi: heat flow direction horizontally

Rse: heat flow direction horizontally, outside: Ventilation level

Upper limit of thermal resistance $R_{tot,upper} = 3,758$ m²K/W.

Lower limit of thermal resistance $R_{tot,lower} = 3,659$ m²K/W.

Check applicability: $R_{tot,upper} / R_{tot,lower} = 1,027$ (maximum allowed: 1,5)

The procedure may be used.

Thermal resistance $R_{tot} = (R_{tot,upper} + R_{tot,lower})/2 = 3,709$ m²K/W

Estimated maximum relative uncertainty according to section 6.7.2.5: 1,3%

Heat transfer coefficient $U = 1/R_{tot} = 0,27$ W/(m²K)

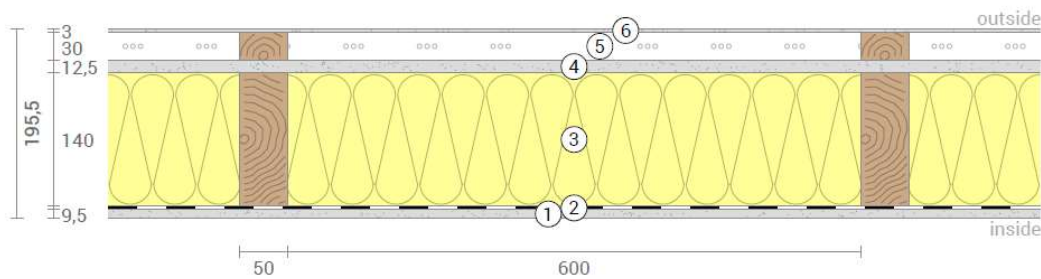

Figure 63 Façade module construction characteristics and U-value. Source: Ubacus

The procedure followed for the calculation of energy savings, based on the evaluation method formulated in chapter 6. In this case, due to the fact that the system is applied to a balcony, a second-skin facade is created. Therefore, the second option will be followed, which takes into account the weighting factor that integrates both the surfaces of the new facade system and the existing surface of the building for the estimation of energy savings.

Table 15, Energy reduction after the implementation of the façade system.

		Temperature weighing factor $a = U_e A_e / (U_e A_e + U_i A_i)$	New energy demand for heating of a typical apartment after the application of the façade system. (MJ)	New energy demand for cooling of a typical apartment after the application of the façade system. (MJ)	Incoming solar energy for a typical apartment that influences the cooling demand. (MJ)	Average total energy demand per typical apartment after the renovation. (MJ)	Percentage of improvement after the application of the façade system to energy reduction renovation.
AMSTERDAM							
NEW WWR=1,46							
opaque surface	15	0,12	1.237	93,8			
transparent surface	22	0,46	3381	256		3.247	68%
total			4.618	349,8	1.528		

Table 16, Energy reduction after the implementation of the façade system

		Temperature weighing factor $\alpha = U_e A_e / (U_e A_e + U_i A_i)$	New energy demand for heating of a typical apartment after the application of the façade system. (MJ)	New energy demand for cooling of a typical apartment after the application of the façade system. (MJ)	Incoming solar energy for a typical apartment that influences the cooling demand.(MJ)	Average total energy demand per typical apartment after the renovation.(MJ)	Percentage of improvement after the application of the façade system to energy reduction renovation.
AMSTERDAM NEW WWR=1,46							
opaque surface	15	0,08	825	62,5			
transparent surface	22	0,46	3381	256		3.026	70%
total			4.206	318,5	1.528		

The energy savings due to the U-values of the new façade system is 70% Nevertheless, the new facade system consists not only of passive design elements but also active, the PV panels. These panels can contribute to the energy reduction of the apartments by using the electric energy produced from the sun for the reduction of the cooling load.

By calculating the electricity produced annually by the PV panels and distribute it to each apartment, the energy reduction can be even greater if heat pumps will be used for cooling and heating of the apartments as they use electric power.

In order to find this extra energy that could contribute to the energy reduction of the building, the total average of kilowatt-hours per year has been calculated and divided by the number of apartments of the building. As a result, 257 kWh which is 925 MJ can be deducted from the total energy demand of a typical apartment after the installation of the façade system.

In this case study building, we assume that the building uses a gas boiler during the heating season and air-conditioning that uses electricity during the cooling season. For this reason, the amount of energy that has been produced from the PV panels can contribute to the energy reduction during the cooling season. The electricity consumption of the air conditioning can be calculated by dividing the cooling demand by the COP (coefficient of performance) which is COP=2.

The total cooling demand according to table 16, is the sum of heat transmission and the incoming solar energy during the cooling period, which is 1846 (MJ). Therefore, the electricity consumption of the air-conditioning is 923 MJ. This means that the electricity produced from the PVs can cover all the energy need for cooling for every apartment. According to aforementioned calculations the total energy reduction including both passive and active measures of the facade system can reach 79% of energy reduction. The percentage of the energy savings has an increase of 9% due to the active properties of The PV as active energy reduction element. The increase from 70 to 79% is because the energy demand during the cooling season has been covered by the PV panels. Therefore, the total energy demand refers only to the energy consumption during the heating season.

Cladding and aesthetic parameters.

The cladding material of the facade modules can vary in terms of materiality as long as it is lightweight and is easy to install. Aluminum and HPL (high-pressure laminate) sheets are two appropriate options of materials for cladding as they can be very thin, easy to assemble, and long-lasting. Additionally, both materials can take different colors and textures through different processes in order to achieve different aesthetical appearances.

In this case, for the building in Amsterdam, aluminum sheets were selected as cladding material with a colorful pattern, in order to give a more playful character to the building. This decision was taken in order to improve the monotonous and repetitive appearance of the building.



Figure 64a, façade system integrated in the building in Amsterdam, SIDE 4.

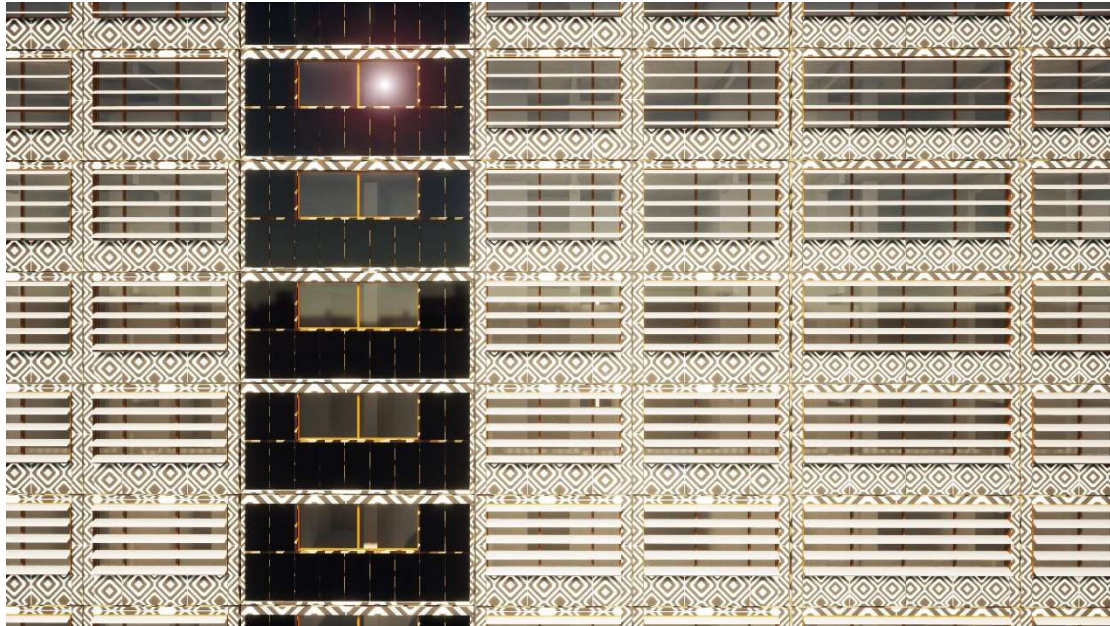

Figure 64b, part of the façade system.

8.2 Variations of the façade system in the building in Athens

Design approach

The design method followed for the renovation of the building in Athens is similar to that one of the building in Amsterdam. However, the climate and the characteristics of the building in this case differ. The same simulation was done based on the location and orientation of the building for the whole year to estimate which side of the building affected more by the sun. This simulation contributed to deciding the energy reduction characteristics that the façade modules will incorporate.

Three types of modules have been developed for the facade renovation system and are shown in figure 65. The development of these types has been formulated in order to cover the different needs of the building envelope with the goal to increase the energy performance.

The functions of the building envelop are two:

1. Private balconies on all sides
2. Vertical common circulation on sides (2) and (4)

The first type of modules that will be part of the façade system will integrate PV panels. This module type has been developed to cover the facade areas of the existing envelope where there are no openings and there is no need for sunlight. The position for this type of façade module will be in front of the vertical circulation on the main façade on side (4). The second area of the building that this module will be installed is on the side (1b). The south part of the building is divided into two surfaces due to the shape of the building. Even though that the side (1) could also be covered with panels according to

the sun path simulation, the building adjacent to this façade creates shadows which means reduced photovoltaic efficiency and for this reason, different module type will be used for side (1).

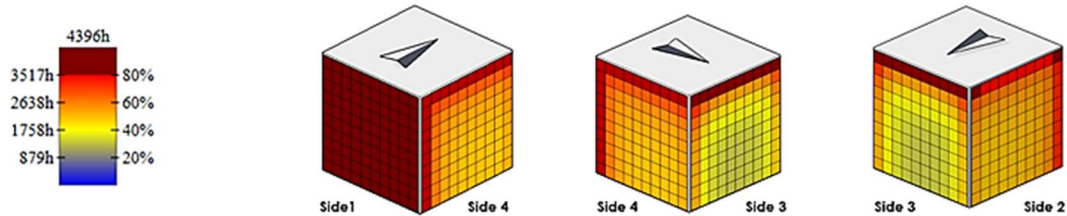

Figure 65, Sun-hours analysis in cubic meter specimen, based on the climate of Amsterdam and the building orientation for the whole year.

The second modular type (2) that has been developed consists of a total opaque wall without openings, to protect the building from the sun and at the same time to increase the thermal insulation. In this climate, protection from the sun is a very important measure to reduce energy consumption according to the passive design principles for warm climates. Therefore this module type will be applied in points where there is no need for sunlight and there are no openings in the existing building envelope. The existing surfaces that this façade module has been designed for, is the whole side (1) and some specific areas on the side (2) where there are no windows as shown in figure 65 and there is also no chance for energy generation from PV panels due to the shading impact from neighboring buildings.

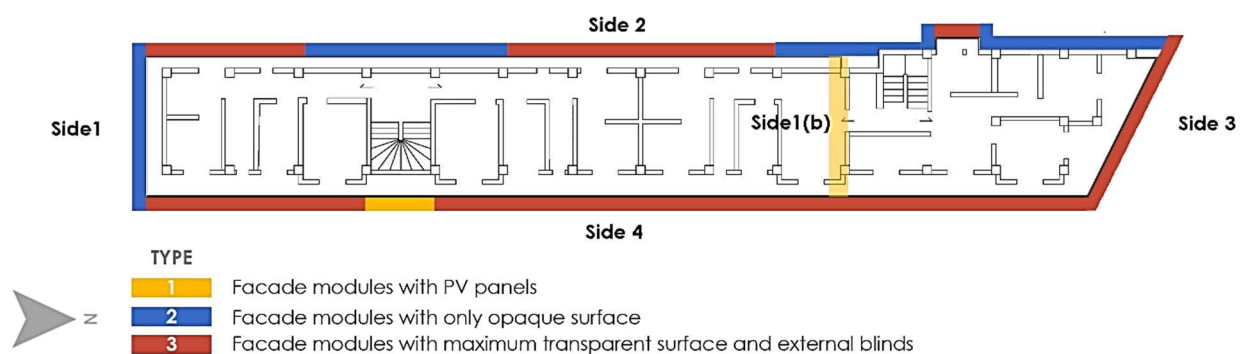

Figure 66, position of the different types of modules of the facade system for energy reduction renovation.

As far as the third module type is concerned, consists of big foldable windows and external roller blinds for sun-shading. The selection of these elements as in the other module types has been formed according to the function of the existing building envelope. This module type has been designed in such a

way so that the occupants will still use their balconies as they are. In mild-warm climates, occupants use the exterior areas more often than people in cold climates. The function of the balcony is achieved when all the glass panes are folded on the side while the lower part of the windows remains and works as glass railing. On the other hand, the use of external blinds is necessary as the big transparent areas increasing the need for cooling during the cooling season. Therefore, this modular type as figure 65 illustrates will be installed on sides (2), (3) and (4) in front of the existing openings.

Attachment approach

Regarding the attachment of the system to the existing building, two different approaches will be used. The first approach has to do with the application of the facade system on a balcony. Therefore, the third option from the variants of the "Generic design" will be used which shows the method that needs to be followed in order to attach the façade system in a balcony. The second attachment approach takes place where a wall surface without balcony is located on side (2). In this area the building envelope consists of a flat external brick wall. Therefore, the second option from the "Generic design" options will be used as it explains the technics to attach the façade modules on a brick wall facade.

Energy reduction approach

As in the previous case study building, after the determination of the design requirements of the modules, the energy reduction principles must be integrated into the façade system. As far as the energy reduction elements that will form the opaque and transparent part of the module frames will be a bit lighter and thinner than those in Amsterdam, as in the building in Athens the system will incorporate lighter energy reduction components and less insulation, due to the fact that the weather is more temperate and the building has different needs. The same tools have been used to define energy reduction characteristics, as in the case study in Amsterdam.

The principles that will be followed to define the energy reduction measures will be based on the selection of the energy reduction elements and the use of the energy tools to define the most optimal solution in terms of energy reduction and functionality. The steps that have been followed have been formulated in the "energy reduction principles" section of Chapter 6.

The aim was to select the most efficient combination of energy reduction elements, in order to reduce the current energy demand of the building while keeping the new facade system as simple as possible. The tools that will be used to achieve the energy reduction are hand calculations, the online tool "Ubakus" for the energy transmission losses, the simulations with the Passive design assistant (PDA), the Sun-hours plug-in to determine the most suitable result of shading and the impact in the g value of the glass. while the PVGIS of the "European Commission" online tool will be used to estimate the energy production from the PV panels.

Design process.

The design process starts by focusing on every side of the building separately in order to clarify the design process of the modules for each façade according to the building characteristics the orientation and the function. The process starts by analyzing the side (1) and the application of the module type (1).

SIDE 1

Stage1:

Firstly, it is necessary to define the positions of the supports for the façade modules according to the "generic Design" principles. The aim was to divide the facade in such a way so that the modules would have the same width and height in order to make the production process of the facade panels easier. As it has been described in the design approach existing building envelope in that side does not have any opening. In addition, according to the orientation and the sun-hours analysis that has been contacted this side is suitable for panel installation as the orientation of the surface is facing South.

The façade grid for the modules is divided into two vertical rows with the same width and height in order to make easier the construction process of the modules. This side of the building will be covered with two types of modules, the type (2) will be installed in the external surface of the three first floors and consists of a total opaque surface with 8 cm insulation while the module type (1) will be installed on the two top floors and consists of the same module characteristics as the module type (2) with the difference that the external surface is incorporates PV panels.

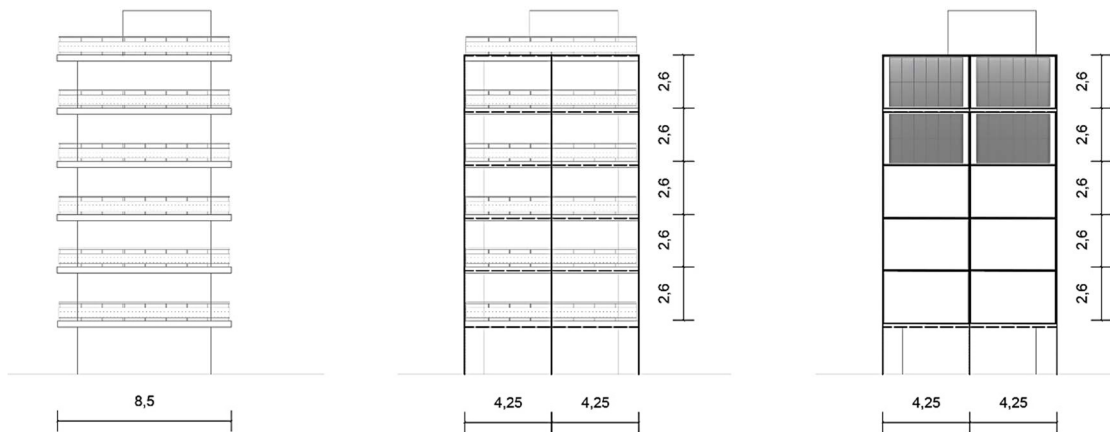

Figure 67, Determination of the grid for the support system and the façade system modules on side (1).

Stage 2: At the second stage of the determination of the façade system on the side (1), there is no need to define the window wall ratio as it will be done for the other types of modules as in this case there are no windows. Therefore, the aim is to define the electricity that can be produced from the façade

module due to the 12 integrated PV panels. For this purpose, the online tool PVGIS of the "European Commission" was used and a table with the average [kWh/PV] has been created to define the energy production of the PV for each side of the building. According to the table 16, a PV panel can produce 8.2 kWh per month which means that every façade module can produce approximately 98 kWh per month. As a result, the four modules can produce around 4.700 kWh of electricity annually.

SIDE 2

Stage 1:

A similar process of defining the position of the vertical supports has been followed as on the side (1) of the building. In this part of the building two different module types will be applied. The first type will be the module type (2) that will be installed in front of the opaque wall of the existing building and the second type, the type (3) is going to be installed in front of the existing glazing areas of the building. After the installation of the system the occupants can decide how they can use the space between the existing and the new façade, as there is an opportunity to expand their floor area of the apartment. In contrast to the building in Amsterdam the apartments in this building give the option to increase the floor area in both sides due to the fact that both sides are private spaces.

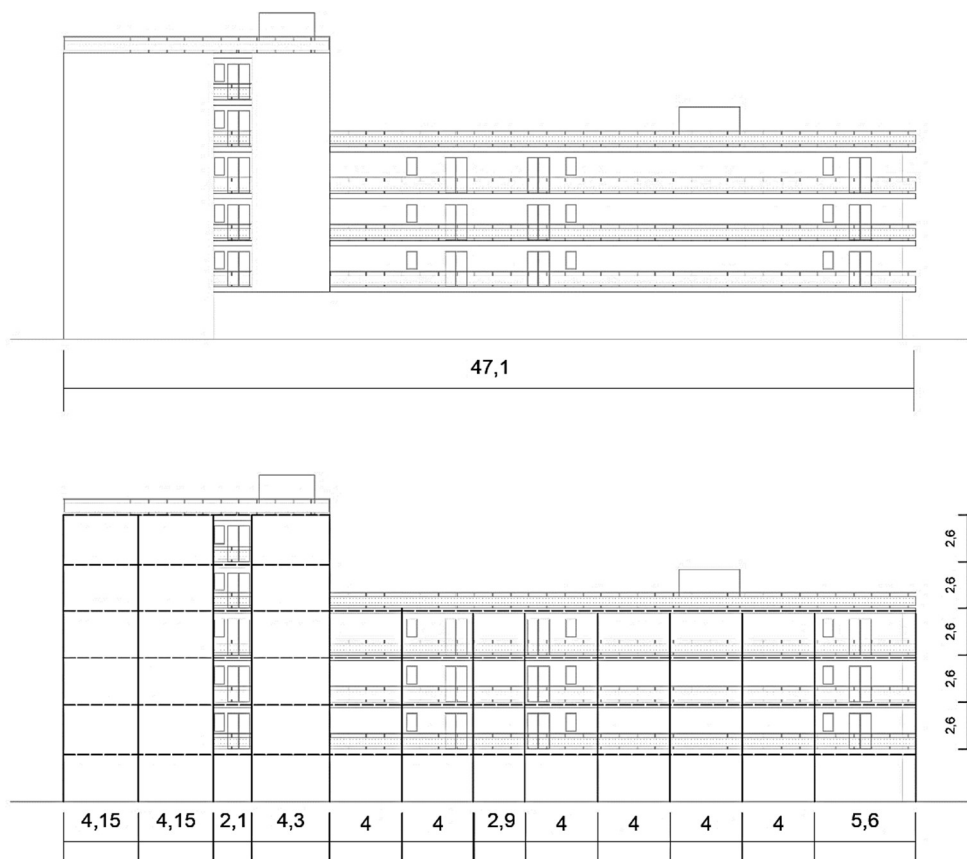

Figure 68, Determination of the grid for the support system and the façade system modules on side (2).

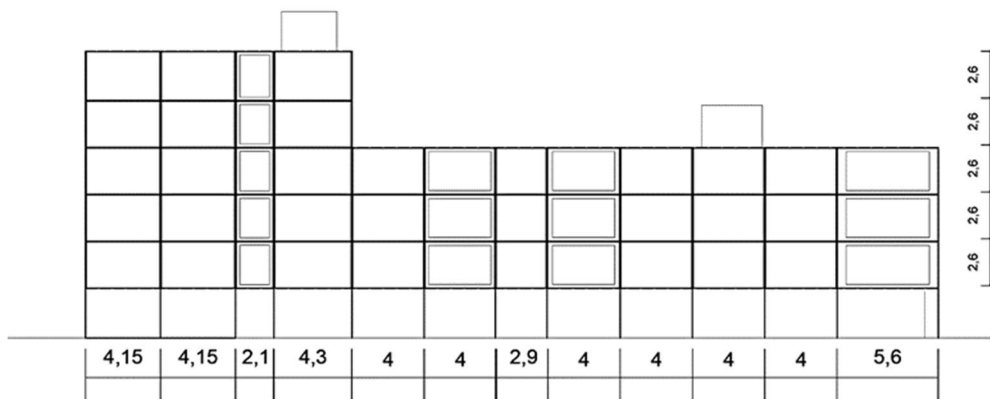

Figure 69, Determination of the final areas of the transparent and opaque part of the modules.

Stage 2:

As far as the window-wall ratio is concerned, the two types of modules on this side of the building have the exact opposite function in terms of window and wall surface. Module type (2) has no windows at all while type (3) has the maximum surface of window due to the fact that they serve different needs. As it was mentioned before, the façade modules need a minimum surface area around the openings to keep the construction stiff, but also in order to incorporate the necessary elements in order to be included in the facade renovation system. Therefore, as figure 70 illustrates the module type (3) that has integrated windows, has a 20 cm perimeter that consists of the structural part of the module in order to be able to incorporate the hinges on the vertical sides for the installation of the module, the insulation, but also to integrate the external roller blind at the top of the windows.

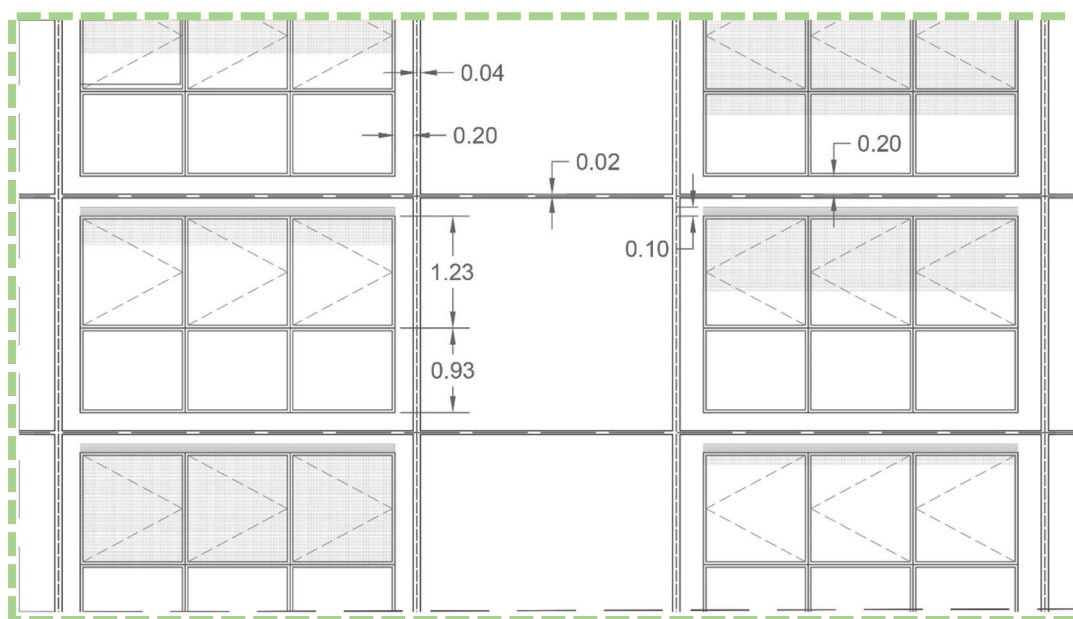

Figure 70, part of the façade system on side (2), modular type (2) and (3)

As mentioned in the design approach and shown in Figure 70, the window area consists of the upper part of the windows which are foldable and can be fully opened, while the lower part is fixed and takes the function of the railing of the balcony. This way there is no need for additional components in the unit to protect occupants when the windows are in balcony mode.

Regarding the tolerances of the modules the same principles have been followed for this façade system as in the case study in Amsterdam following the guidelines of the “Generic Design”.

SIDE 3

The first step as in all the building sides is to define the grid of the supports of the façade system. For the side (3) the façade divided into two columns and the façade system consist of one type of module, type (3). This type was selected due to the orientation and the function of the existing envelope that has windows and needs shading at some hours during the day. There is no alternative option to select a different module type for this building side, as it faces north, therefore no reason to incorporate PV panels in the modules due to the low solar irradiation. In addition, smaller windows in the façade will not maintain the balcony character which is one of the goals.

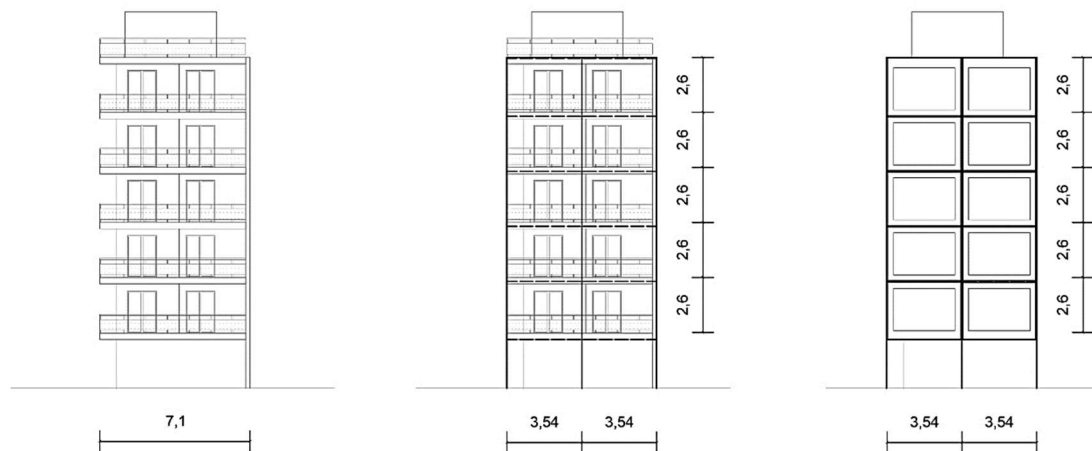

Figure 71, Determination of the grid for the support system and the façade system modules on side (3).

SIDE 4

Stage 1:

The position of the supports is placed in such a way to achieve as much as possible the same modules in order to contribute in a more industrialized way of production with the aim to reduce the cost and the construction time of facade modules.

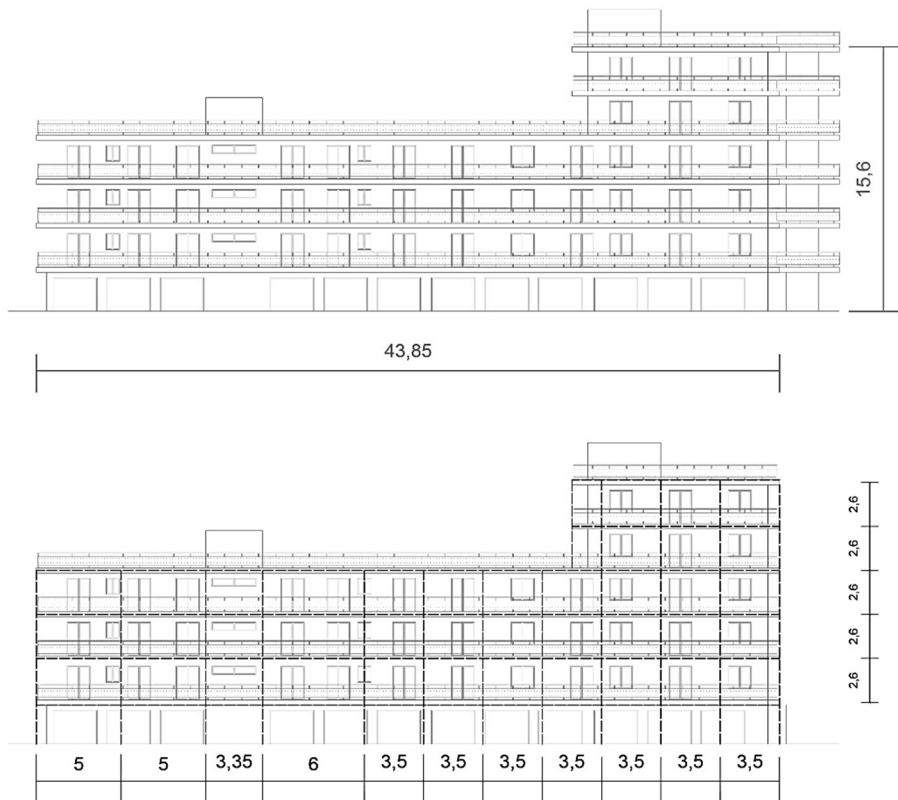

Figure 72, Determination of the grid for the support system and the façade system modules.

Stage 2:

In this stage the position of the two module types is determined. All the existing façade will be covered with the module type (3) for the same reasons that have been already said in the previous cases except the façade area that is in front of the common vertical circulation. In this surface the module type (1) will be installed in order to take advantage of the solar irradiation.

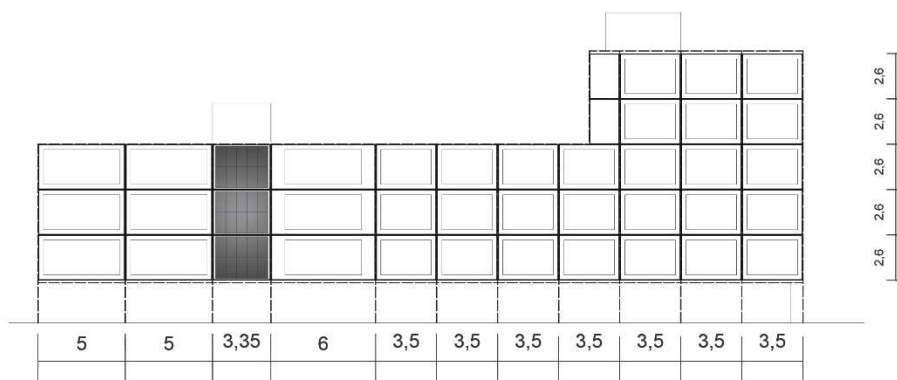

Figure 73, Determination of the position of the façade system modules type (1) and (3).

Stage 3:

To estimate the energy production from the PV panels table 16 will be considered which indicates the power that can be produced from a PV for this side.

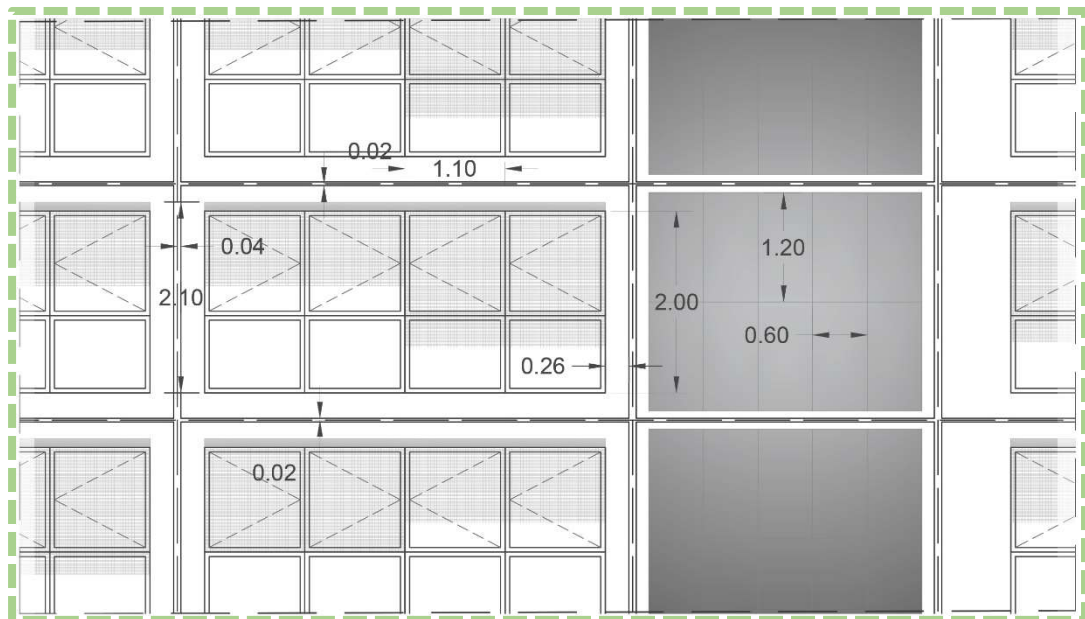

Figure 74, part of the façade system on side (4) modular type (1) and (3).

Each PV can produce an average of 6.4 KWH per month and there are three façade modules that incorporate ten PVs each. Therefore, they can produce an average of 192 kWh per month which means around 2.300 kWh per year.

Table 17, Electricity Production of a PV panel according to the building side.

Month	SIDE 1(b) Monthly electricity production (kWh)/PV	SIDE 4 Monthly electricity production (kWh)/PV
January	9,4	3,5
February	8,3	4,2
March	9,8	6,2
April	8,1	7,5
May	6,3	8,7
June	5,1	9,1
July	5,7	9,5
August	7,8	8,8
September	9,5	7,1
October	9,9	5,2
November	9,6	3,8
December	8,8	3,1
Average	8,2	6,4

Critical points of the façade renovation system

In order to show the adjustability properties of the façade system as in the previous application of the system in Amsterdam, two critical points have been selected to show the small modifications that the system can take in

order to apply in every case scenario. In this case study application, two critical points selected to show a modification that could be necessary in some cases in order to achieve the coverage of an existing building façade with the system and different dimensions that the system can take according to the structural and energy reduction needs.

As figure 73 shows, the system in the building in Athens has adjusted the thickness of the timber-frame structure of the module, as there was no need for extra structural stability due to the fact that no heavy energy reduction elements or thick insulation are incorporated, to increase the cross-section of the frame supports. This result stems from the impact of the mild climate that this building is located in and the design decisions that have been made due to the function of the building.

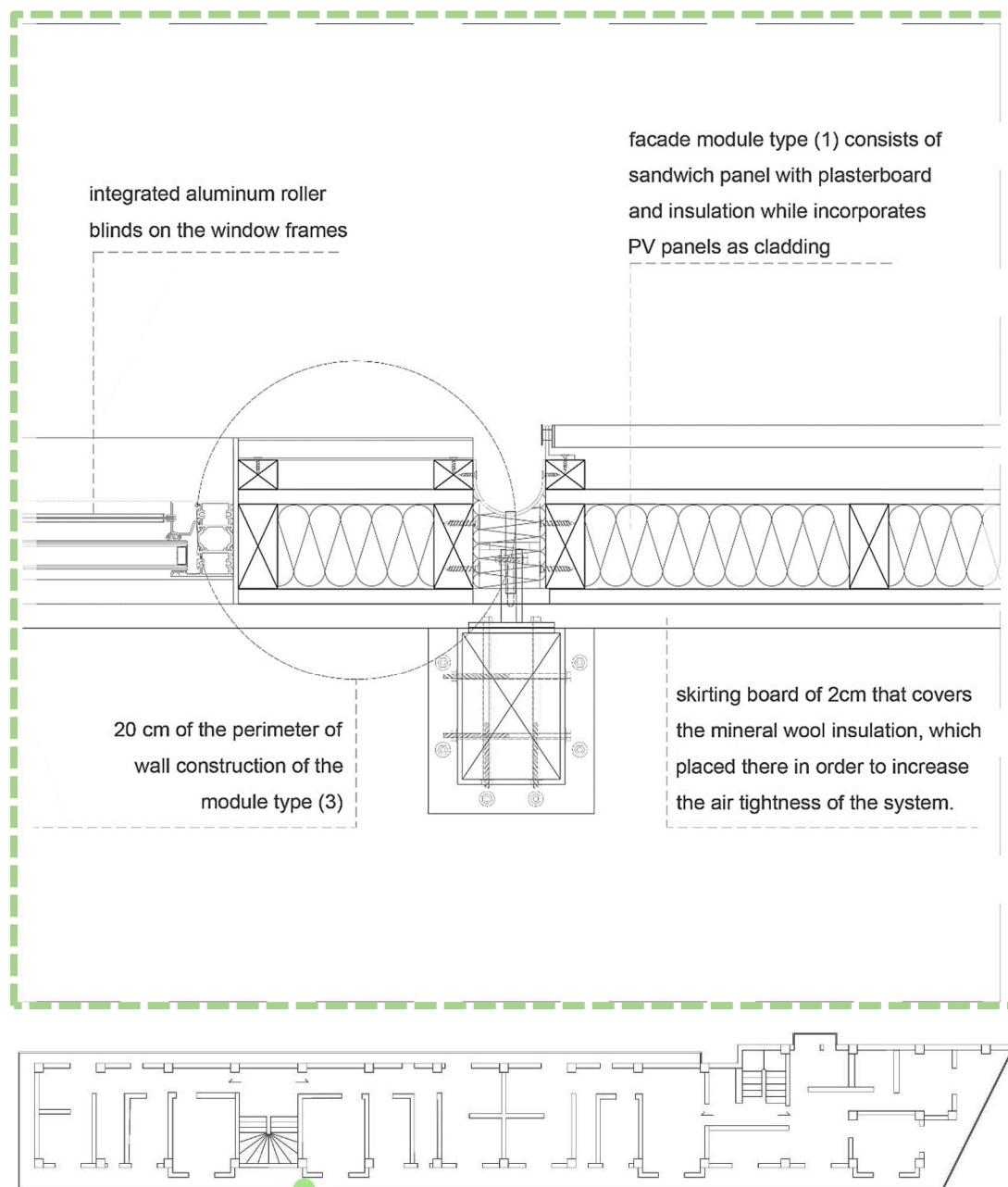

Figure 75, Detail in top view between module type (3) and (1). The green dot indicates the position of the detail.

In figure 75 illustrates the connection between two different option in an angle the is less than 90 degrees and in different envelope characteristics as the one module is attached on a brick wall and the other in a balcony. As it is shown in the detail there is a modification in the shape of the cross-section of the vertical timber support of the module in order to be able to attach to the metal hook. This is something that can be done in case of a similar situation.

Additionally, due to the shape of the corner, an on-site installation of mineral wool insulation and aluminum cladding is necessary in order to cover the thickness of the brick wall between the two modules as the 'Generic design approach cannot cover this part with the standardized way.

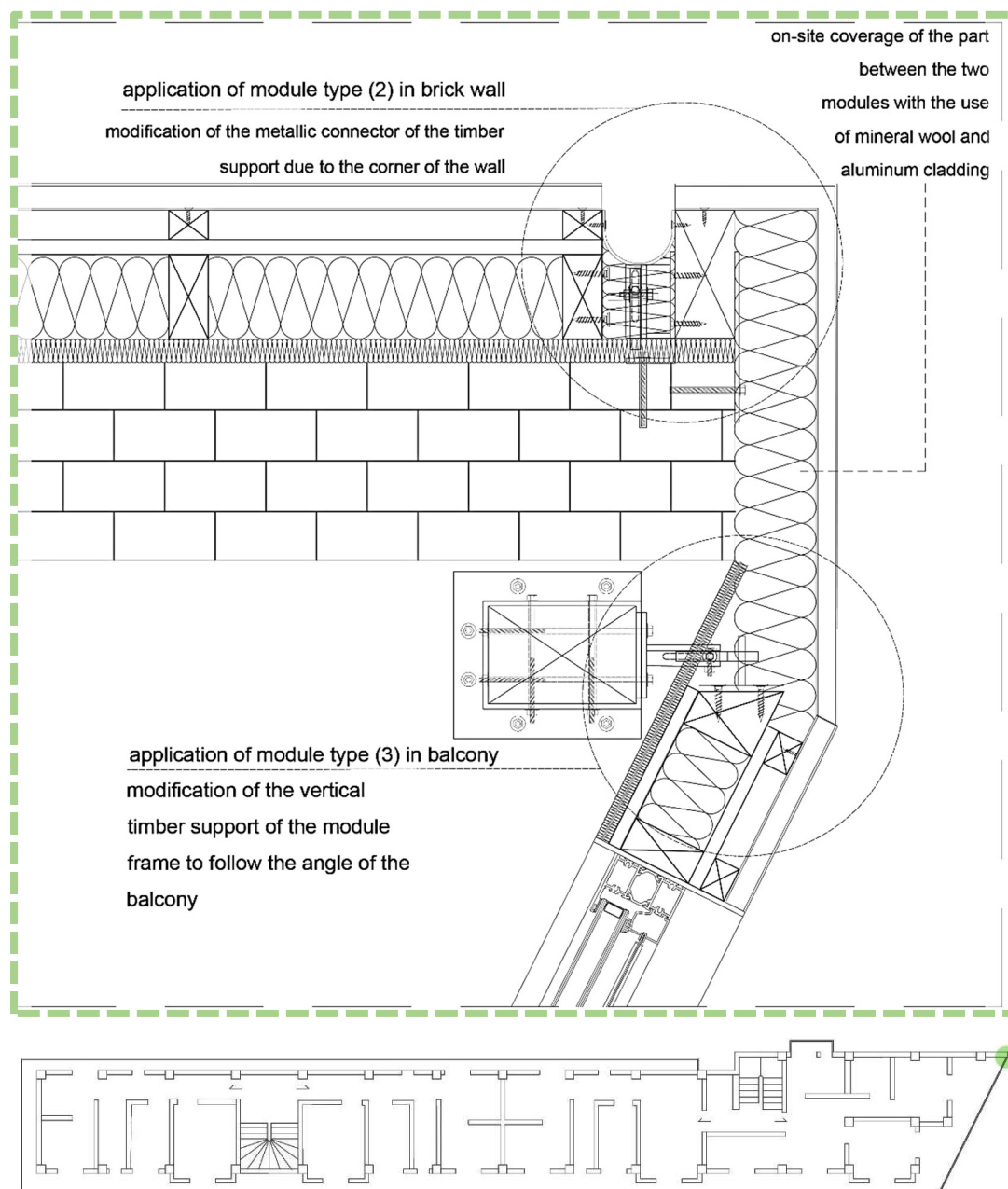

Figure 76, Detail in top view between module type (3) and (2) in a corner. The green dot indicates the position of the detail.

Energy reduction Principles

In order to define the impact of the installation of the facade system on the energy demand of the building in Athens, a typical apartment has been chosen to be analyzed according to the principles that have been formulated in the "Generic Design" section.

The goal of energy reduction is to achieve energy savings of at least 50% relative to the current energy consumption of the building. In addition to the energy reduction goal, the goal is also to check the performance of the system according to the selection of energy reduction elements in the previous stages.

In order to get the final result of the energy reduction, the overall new U-value of the new façade system has been used to indicate the energy reduction after the application of the system.

In order to define the u-value of the opaque part of the new system, the online tool "Ubakus" was used. The selection of the energy reduction elements has been made based on the principles that have been formulated in the energy reduction principles section

As in the first case study building two different construction variations for the opaque part of the system have been calculated. The one has 8cm insulation and U-value =0.43 W/(m²K) and second one has 14 cm insulation and U-value =0.27 W/(m²K). The first option as it is depicted in table 19, gives a total energy savings of 73%. The second option as it is showed in table 20, gives a total energy savings of 75%.

In this case, the thinnest type of module will be used, as the whole system in most cases incorporates windows and external shutters, which does not require very large cross-sections in the structural skeleton of the modules as the shutters are much lighter compared to the external louvers.

As far as the U-value of the transparent part of the system is concerned, a window with double glazing and Low-E has been selected with $U = 1.3 \text{ W / (m}^2 \text{ K)}$ and g-value = 0,15 after the application of the shading system. The g value of 0.15 is achieved when the external roller blinds are completely closed. This situation will not be the case in the real life therefore the calculations are based on the ideal scenario where the building performs as efficient as possible.

U-Value calculation according to DIN EN ISO 6946

#	Material	Dicke [cm]	λ [W/mK]	R [m ² K/W]
Thermal contact resistance inside (Rsi)				0,130
1	Gypsum board	0,95	0,250	0,038
2	Vapor retarder sd=2,3m	0,05	0,220	0,002
3	ROCKWOOL Varirock 035	8,00	0,035	2,286
	Spruce (6,2%)	8,00	0,130	0,615
4	Breather membrane sd=0,1m	0,05	0,500	0,001
5	Gypsum board	0,95	0,250	0,038
Thermal contact resistance outside (Rse)				0,130

Thermal contact resistances have been taken from DIN 6946 Table 7.

Rsi: heat flow direction horizontally

Rse: heat flow direction horizontally, outside: Ventilation level

Upper limit of thermal resistance $R_{tot,upper} = 2,366$ m²K/W.

Lower limit of thermal resistance $R_{tot,lower} = 2,293$ m²K/W.

Check applicability: $R_{tot,upper} / R_{tot,lower} = 1,032$ (maximum allowed: 1,5)

The procedure may be used.

Thermal resistance $R_{tot} = (R_{tot,upper} + R_{tot,lower})/2 = 2,330$ m²K/W

Estimated maximum relative uncertainty according to section 6.7.2.5: 1,6%

Heat transfer coefficient $U = 1/R_{tot} = 0,43$ W/(m²K)

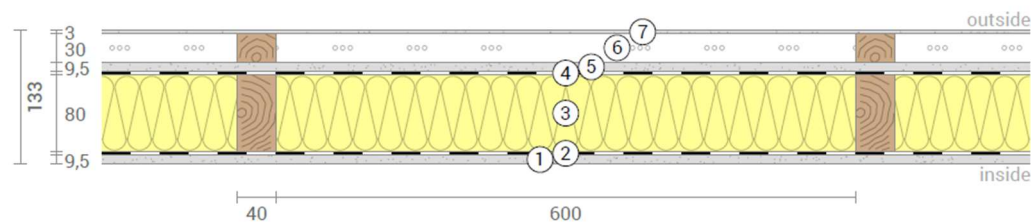

Figure 77, Façade module construction characteristics and U-value of the module that is used for the case in Athens. Source: Ubacus

The procedure followed for the calculation of energy savings, based on the evaluation method formulated in chapter 6. In this case, due to the fact that the system is applied to a balcony, a second-skin facade is created. Therefore, the second option will be followed, which takes into account the weighting factor that integrates both the surfaces of the new facade system and the existing surface of the building for the estimation of energy savings.

Table 19, Energy reduction after the implementation of the façade system

		Temperature weighing factor $\alpha = U_e A_e / (U_e A_e + U_i A_i)$	New energy demand for heating of a typical apartment after the application of the façade system. (MJ)	New energy demand for cooling of a typical apartment after the application of the façade system. (MJ)	Incoming solar energy for a typical apartment that influences the cooling demand.(MJ)	Average total energy demand per typical apartment after the renovation.(MJ)	Percentage of improvement after the application of the façade system to energy reduction renovation.
ATHENS							
NEW WWR=1,58							
opaque surface	17	0,13	616	615			
transparent surface	27	0,33	2.338	2.334		4.148	73%
total			2954	2949	2.393		

Table 20, Energy reduction after the implementation of the façade system

		Temperature weighing factor $\alpha = U_e A_e / (U_e A_e + U_i A_i)$	New energy demand for heating of a typical apartment after the application of the façade system. (MJ)	New energy demand for cooling of a typical apartment after the application of the façade system. (MJ)	Incoming solar energy for a typical apartment that influences the cooling demand.(MJ)	Average total energy demand per typical apartment after the renovation.(MJ)	Percentage of improvement after the application of the façade system to energy reduction renovation.
ATHENS NEW WWR=1,58							
opaque surface	17	0,08	379	378			
transparent surface	27	0,33	2.338	2.334		3.911	75%
total			2.717	2.712	2.393		

The energy savings due to the U-values of the new façade system is 73% Nevertheless, the new facade system consists not only of passive design elements but also active, the PV panels. These panels can contribute to the energy reduction of the apartments by using the electric energy produced from the sun for the reduction of the cooling load.

As in the first case study building, the façade system for energy reduction includes not only passive measures but also active PV panels. Following the same steps as in the case in Amsterdam, the total kWh that the building can produce due to the PV panels that are located in the side (1b) and (4) annually is 7000 kWh per year which is 25.500 MJ.

The total number of apartments in the building is 14. As a result, in every apartment correspond around 1800 MJ that can contribute to the reduction of the energy demand.

The energy that has been produced from the PV will be deducted from the cooling demand as for cooling the building uses air conditioning. The energy demand for cooling is 5.342 MJ which means with an air conditioner with COP =2 needs 2.671 MJ of energy for cooling. By deducting the energy produced from the PVs from the energy demand for cooling the final energy is 871 MJ. This result is considered as the new cooling energy demand for the building after the application of the system. Thus the final energy savings considering both passive and active energy reduction components of the facade system is around 90%

Cladding and aesthetic parameters.

As it was described in the case study building in Amsterdam, the cladding material of the facade modules can vary in terms of materiality as long as it is lightweight and is easy to install.

In this case, for the building in Athens, aluminum sheets were selected as cladding material as in the previous case.

The light color of the cladding was selected in order to achieve a visual contrast with the dark gray roller blinds of the modules, but also in order to reflect the sun due to the fact that in this area the solar irradiation reaches high levels.



Figure 78a, façade system integrated in the building in Greece.

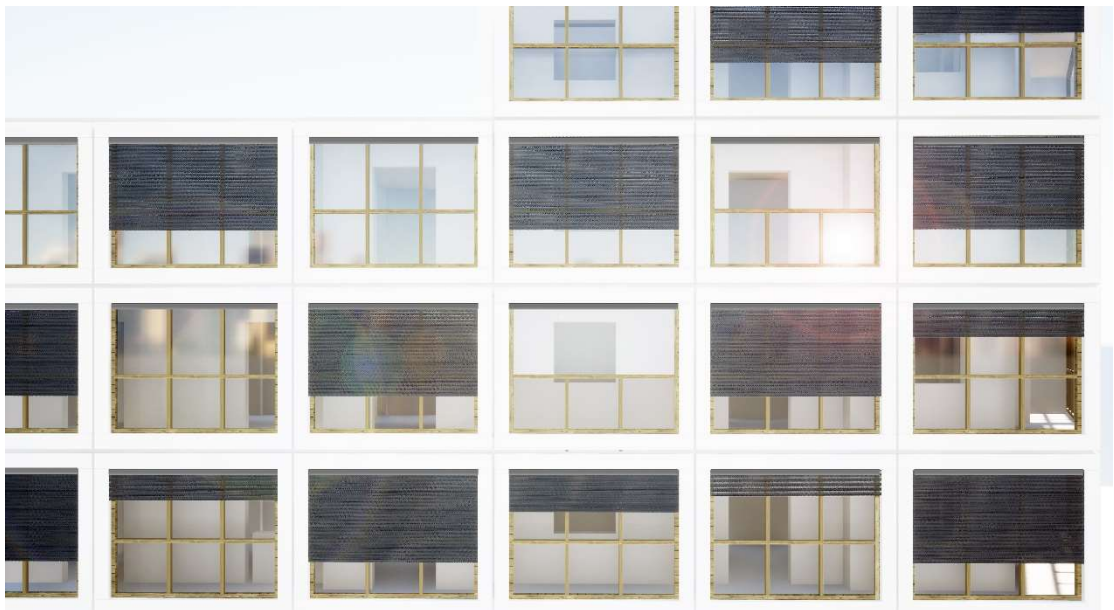

Figure 78, façade system integrated in the building in Greece.

8.3 System Overview

In this chapter, an overview of the facade system for energy reduction renovation will be presented with the aim to clarify the steps that need to be followed in order to apply the system in existing buildings. Additionally, a list of the parts of the system is created with the aim to define the properties of the system's parts and their limitations.

The diagram that will follow is a representation of the main steps that need to be followed to create the facade system by determining the main considerations for the design of the system. The process is divided into two stages. The first stage is the explorative part, where the existing building needs to be analyzed by following four different steps. The second stage is the development part where the determination of the new product is taking place.

Stage: 1

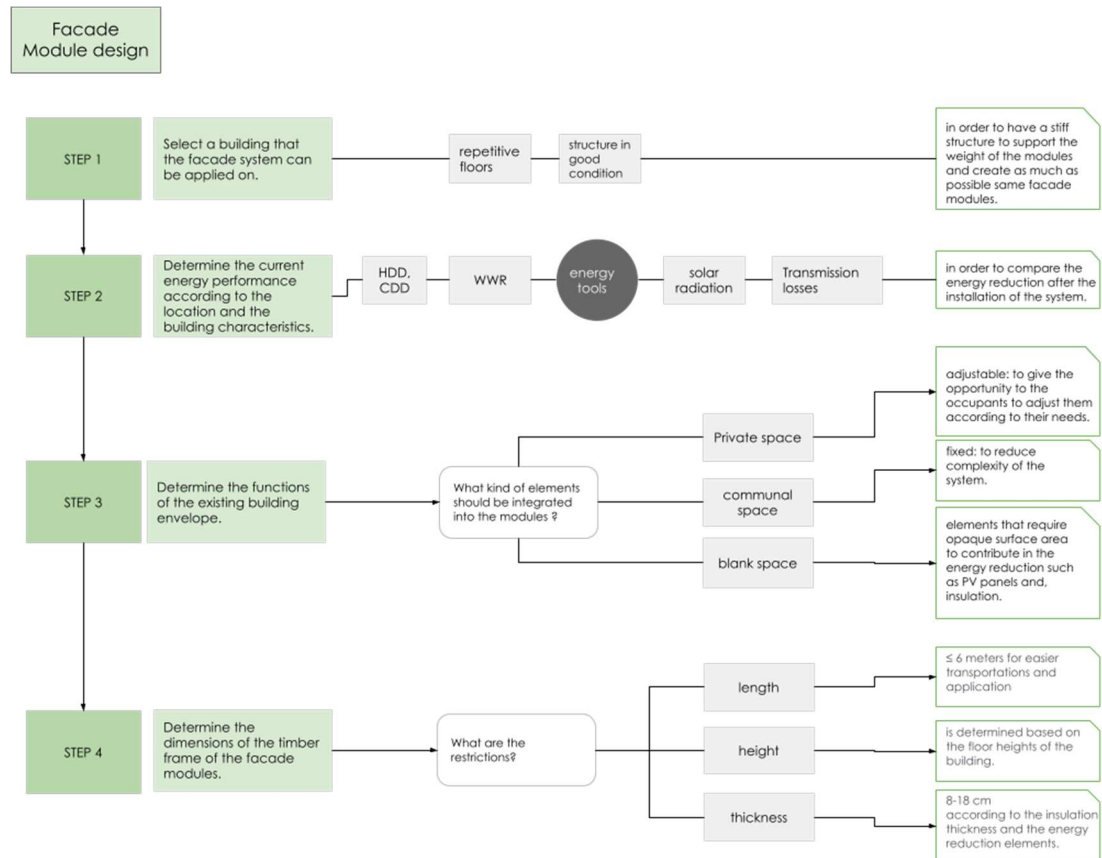

Step1: In the first step, the structural condition of the existing building and the typological character needs to be defined. This step is necessary in order to check if the structure can support the extra weight of the modules. To proceed with the next step, the building needs to follow the same layout on all floors. This precondition is necessary in order to achieve maximum coverage of the building with the facade system with as much as possible the same facade modules.

Step2: The second step is to determine the current energy efficiency of the building. This step includes calculations and simulations using the energy tools described in Chapter 6 in the section "Evaluation of the energy reduction components". This step will help to define the appropriate energy reduction elements for the façade renovation system.

Step3: In the third step, the functions of the existing building shell must be defined in order to determine the character of the facade units of the system. The modules, depending on the needs, can incorporate elements that the occupants can adjust or not. This process is explained in the "Design approach" section in Chapter 8 for both case study buildings.

Step4: In step 4, the dimensions of the modules need to be defined based on the design guidelines that are explained in the "Generic Design principles and tools" in Chapter 6.

Stage: 2

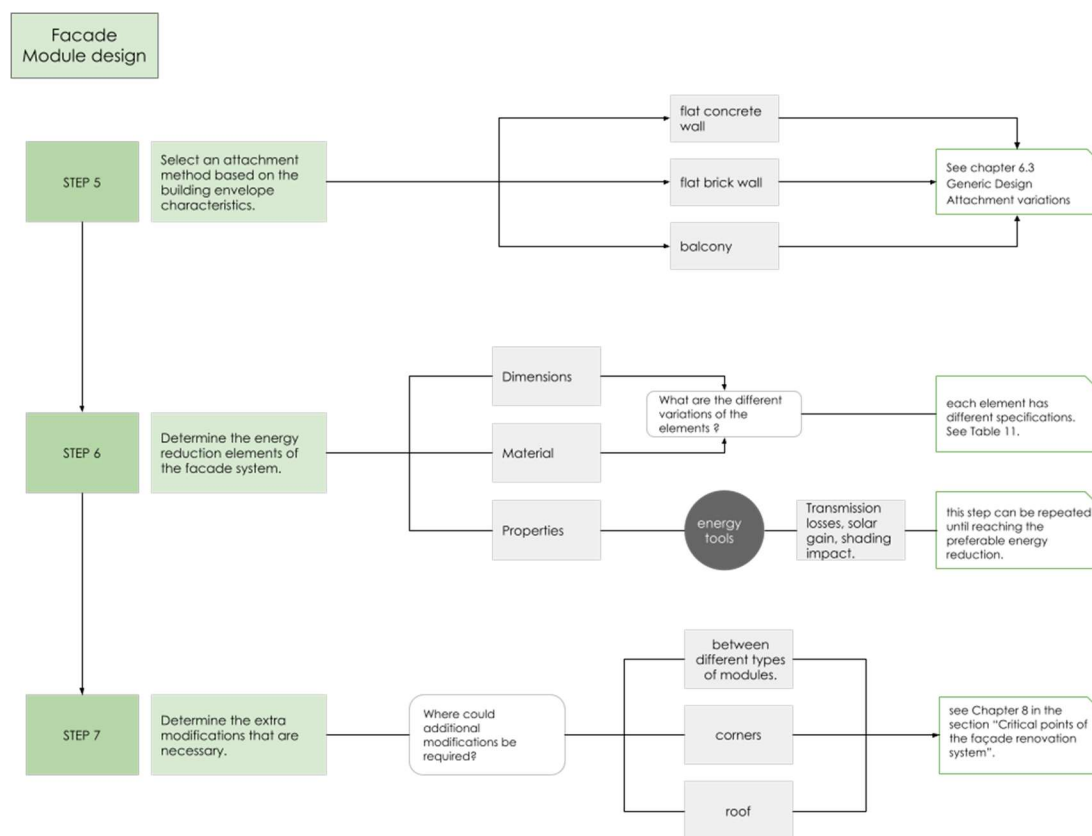

Step 5: In the fifth step, the attachment method of the modules in the existing building envelope has to be defined based on the existing surface characteristics of the building. The options of the attachment can be found in Chapter 6 in section "Attachment variations".

Step 6: In the sixth step, the selection of the appropriate energy reduction elements for the facade renovation system is taking place. The way to select the most suitable element starts by searching in table 11 where all the elements are listed with their properties. Additionally, further calculations need to be made in order to decide specific parameters of the energy reduction elements that have been selected from the list. The energy tools that help to decide which parameters to choose can be found in Chapter 6 in the section "evaluation of the energy reduction elements" but also in Chapter 8, where the process of the application of the design is demonstrated step by step.

Step 7: In the last step, the points where the system will need extra modifications during the installation process have to be defined. Examples of this process can be found in Chapter 8 in the section "Critical points of the façade renovation system".

In addition to the steps to follow for designing the facade system, a list of system parts was created to briefly explain what the main properties of the system components are, what the designer's choices are, and what kind of adjustments can be made.

Table 21, façade system parts and properties

	Façade system parts.	Dimensions		Material	
		adjustable	Fixed	Standard	Vary
1	Structure	✓		✓	
2	connectors	✓		✓	
3	insulation	✓		✓	
4	Plasterboard	✓		✓	
5	cladding	✓			✓
6	windows	✓		✓	
7	PV panels		✓	✓	
8	Louvers	✓		✓	
9	Roller blinds	✓		✓	

1. The structure consists of timber beams with cross-sections of 8-18 cm by 4-6 cm and a maximum length of 6 meters.
2. The connectors are produced in standard size but can be adjusted according to the needs, and are made out of steel.
3. The insulating material is mineral wool. The dimensions of the insulation can be adjusted using more than one insulation sheet for large surfaces, while for small surfaces by cutting the standard size of the insulation sheets to smaller sizes.
4. Plasterboard is produced in standard sizes but can be adjusted by cutting it in the appropriate size or by adding more than one sheet in the modules to cover the needed surface. The selection of this specific plasterboard is explained in "Chapter 6" in the section "Energy reduction principles".
5. The cladding material can vary according to the client's needs, with the precondition that the selected cladding material will not add too much weight to the façade module.

6. The window opening can have any dimension with the only restriction that the structural part of the facade module needs a minimum perimeter of 20 cm.
7. The PV panels have standard dimensions of 60 by 120 cm and the material is determined by the production company. More details can be found in Chapter 6 in Table 11.
8. The dimensions of the louvers can be adjusted according to the shading needs. However, the material of the louvers is aluminum as it is a very lightweight material and weather resistant. The orientation can also be adjusted in horizontal and vertical direction while the shape of the aluminum profile can have small variations based on the construction company's standards. The link can be found in Table 11.
9. The dimensions of the roller blinds can be adjusted according to the shading needs. However, the material of the louvers is aluminum as it is a very lightweight material and weather resistant. More details can be found in Table 11.

Conclusions

For both applications of the facade system to the different building-climate scenarios, turned out that the "Generic Design" can be applied in most of the surfaces due to the different options of adjustment. However, there would be probably some small surface points in the buildings that will need further modifications on-site. Nevertheless, these points consist of a very small percentage of the surface in comparison with the total building envelope surface that the facade system with the standardized way can cover.

In terms of energy reduction elements have been shown to be able to increase the energy efficiency of the building more than expected. However, some energy reduction elements after a point do not drastically affect the energy reduction, even though they may take different variants. A typical example is the insulation element. After one insulation thickness, the energy reduction effect was very small.

On the other hand, the energy reduction elements, such as the shading systems, affect drastically the performance of the system. For instance, adjusting the width and the spacing between louvers can contribute to greater energy reduction impact due to the fact that the solar irradiation and the window-wall ratio is one of the most important factors that affect the performance of a building.

As far as the accuracy of the energy reduction results is concerned, the procedure followed to determine the energy reduction elements was based on simplified methods of simple hand simulations and calculations in order to select the appropriate energy reduction elements to achieve the energy reduction goal. This means that further simulations can be made to define the impact of the system more accurately.

Nevertheless, the purpose of the system was not only to improve the energy performance of the building but also to improve the aesthetic appearance of the building. There is no doubt that because of the simple flat character of the facade modules, the final typological result will be more or less the same, as all the buildings that will use this kind of system will be transformed in cubic volumes. However different aesthetic results can be achieved using different combinations of the elements and different cladding textures.

The overview in the last part of this chapter was created in order to indicate the steps and the properties of the system's parts with the aim to help to understand how the system works. Additionally, the distinction between the two stages the explorative and the development part was defined not only in order to clarify the general idea but also to indicate how a building needs to be approached in order to apply the facade system.

9. Conclusions

The thesis started by emphasizing that it is necessary to find a way to renovate the existing building stock of Europe in order to achieve the goals set by the European Union by 2050. To tackle this problem an adjustable system that can be implemented in different building situations was considered as the appropriate solution. These building situations are not only the building characteristics, but also the climate characteristics, that will define the renovation approach.

By researching the climate in different countries around Europe the building stock in Europe and the renovation best practices, the adjustable prefabricated facade system for renovation has been developed.

There are three main properties that render the system adjustable. The first important part is the structural part of the system that can vary in size so that the system can be applied in different building facades. The second part is that the system consists of three different methods of attachment. This way gives the option to the user of the system to select the appropriate method according to the building envelope construction and characteristics that wants to renovate. These two parts have to do with the geometrical characteristics of the building. However, as it was mentioned, the system needs to be adjustable also in terms of climate in order to adapt to different weather conditions. Therefore, the third main characteristic of the system which makes it adjustable is that incorporates energy reduction elements that contribute to the energy reduction of the building. The selection of the energy reduction components has been done based on the variations that they can take, not only in terms of energy reduction but also size.

Having these three aspects of adjustability the system is possible to be applied in various buildings in Europe helping to reduce the CO₂ emissions while increasing thermal comfort in the old residential buildings that are in need. Additionally, the prefabricated character of the system can contribute to a mass production renovation that can save time and reduce the cost of energy-reduction renovation. The overall renovation system can be used by architects, engineers and product developers. This particular system is not only a method of improving the energy efficiency and the appearance of existing buildings but also can be seen as a product in a market that is in need of a fast renovation solution.

Through this thesis project, it was attempted to point out some of the challenges that we will face in the near future in the field of building renovation and some solutions were given. There is no doubt that further research and applications in actual buildings are necessary until

the product can be released on the market. Nevertheless, some of the points that this thesis presents can be used as information in cases where such kind of a renovation model can work financially.

Answer Research Question

“How a prefabricated facade system for energy reduction renovation of residential buildings can be designed to be adjustable in different building typologies and climates?”

The research question consists of a different segment: prefabricated, energy reduction, residential buildings, adjustable in different building typologies and climates. Each segment will be answered separately.

The proposed system is determined as prefabricated due to the fact that uses components that can be manufactured in factory settings, while at the same time consists of products that are already on the market. In addition, the overall system consists of principles that determine the dimensions of the modules in order to facilitate the construction, the transportation, and the installation of the modules.

The energy reduction is achieved by incorporating energy reduction measures into the system following passive and active design principles.

The system is aimed at residential buildings, as these buildings represent the largest percentage of the existing building stock in Europe and consist of simple constructions and simple typological features while at the same time consume the most energy due to the poor energy construction characteristics

Finally, the main objective of the thesis that refers to the design of an adjustable facade system for renovation for different typologies and climates is achieved through the formulated principles of the "Generic Design".

The adjustability of the system in different building typologies is achieved through two main factors. The first is due to the different lengths and heights that the modules of the system can take according to the existing dimensions and functions of the building envelope, while the second factor refers to the different attachment variations of the system that can be selected according to the construction of the existing building envelope.

As far as the ability of the system of being adjustable in different climates is concerned, is achieved due to the properties of the energy reduction elements that are integrated into the facade modules of the system, which can be modified accordingly during the design process of the system, in order to achieve the desired energy reduction goal. The energy reduction elements not only can be modified in terms of energy performance but also in terms of dimensional adjustability in order to keep pace with the structural part of the system.

Recommendations

Financial: Additional research is needed on the viability of the design solution in terms of financial aspects. Funding is one of the main determinants of the implementation of a new system.

Production: The production of prefabricated renovation system is a crucial part in determining the success of a solution. Further improving the production line in terms of time and costs would benefit the incentive to use such systems.

Customization: More customization options would potentially increase the motivation for stakeholders to utilize the system and acceptance by occupants.

Energy reduction: Further research is needed in the energy reduction part of the façade system with more accurate calculations in order to get results that are more realistic and closer to the actual impact of the system.

References

Andreas Hermelink, Sven Schimschar, Thomas Boermans. *Towards nearly zero-energy buildings, Definition of common principles under the EPBD*. 2013.

Annex50, IEA. *Project Summary Report*. In: Zimmermann, M. (ed.). United Kingdom: AECOM Ltd, 2012.

Bart MacCarthy, Philip G. Brabazon, Johanna Bramham. «Fundamental Modes of Operation for Mass Customization.» *International Journal of Production Economics* 85(3):289-304, September 2003.

BEAR. *European climate zones and bio climatic design requirements*. Technalia, 2016.

BPIE, Aleksandra Arcipowska, Filippos Anagnostopoulos, Francesco Mariottini, Sara Kunkel. *ENERGY PERFORMANCE certificates across the EU*. BPIE, 2014.

BPIE, Europe Buildings Performance Institute. *Europe's buildings under the microscope, A country-by-country review of the energy performance of buildings*. BPIE, 2011.

Capeluto, Guedi. «Adaptability in envelope energy retrofits through addition of intelligence features.» 11 Feb 2019.

Cecília G. da Rocha, Carlos T. Formoso, Patrícia Tzortzopoulos. «Adopting Product Modularity in House Building to Support Mass Customisation.» 24 April 2015.

Commission, European. «European energy and transport: trends to 2030.» 2007.

D. W. HE, A. KUSIAK. «Performance analysis of modular products, *International Journal*.» 1996.

Doreen E. Kalz, Jens Pfafferoth. *Thermal Comfort and Energy-Efficient Cooling of Nonresidential Buildings*. Springer, 2014.

Giebeler, G. (2009). . Basel: Birkhäuser. *Refurbishment manual: maintenance, conversions, extensions*. Basel: Birkhäuser, 2009.

Hitchin, E. R. «Degree-days in Britain.» *SAGE Journals*, May 1981.

Hu Du, Puxi Huang, Phillip Jones. «Modular facade retrofit with renewable energy technologies: The definition and current status in Europe.» 2019.

Itard, L & Meijer, F. *Towards a sustainable Northern European housing stock (Vol. 22)*. Amsterdam: IOS, 2008.

J. K. Gershenson, G. J. Prasad, Y. Zhang. «Product modularity: Definitions and benefits.» 2 August 2010.

K. Ulrich, K. Tung. «Fundamentals of product modularity.» 1991.

Katerina Tsikaloudaki, Kostas Laskos, Dimitrios Bikas. «On the Establishment of Climatic Zones in Europe with regard to the energy performance of buildings.» *energies*, 29 December 2011.

Konstantinou Thaleia, Prieto Hoces Alejandro. *Environmental Design Principles for the Building Envelope and More, passive and active measures*. 2018.

Konstantinou, Thaleia. «Façade Refurbishment Toolbox.» *Architecture and the Built environment*, 2014.

Konstantinou, Thaleia, Olivia Guerra Santin, Juan Azcarate Aguerre, Tillmann Klein, και Sacha Silvester. «A zero-energy refurbishment solution for residential apartment buildings by applying an integrated, prefabricated façade module.» 2017.

L. Adityaa, T.M.I. Mahliaa, B. Rismanchi , H.M. Nge, M.H. Hasane, H.S.C. Metselaare, Oki Muraza, H.B. Aditiya. «A review on insulation materials for energy conservation in buildings.» *Renewable and Sustainable Energy Reviews*, 2017.

Maarten De Groote, Marianne Lefever. *Driving transformational change in the construction value chain*. Buildings Performance Institute Europe (BPIE), 2016.

Maarten Meijs and Ulrich Knaack. *Components and Connections, Principles of Construction*. Birkhäuser, 2009.

Macdonald, S. *Concrete: Building Pathology: Wiley*. 2003.

MARSHALL, R., LEANEY, P. G. and BOTTERELL, P. « Enhanced product realisation through modular design: an example of product/process integration, *Journal of Integrated Design and Technology*.» 1998.

Michele De Carli, Adriana Bernardi, Matteo Cultrera, Giorgia Dalla Santa, Antonino Di Bella , Giuseppe Emmi, Antonio Galgaro, Samantha Graci, Dimitrios Mendrinos, Giulia Mezzasalma, Riccardo Pasquali, Rodolfo Perego and Angelo Zarrella. «A Database for Climatic Conditions around Europe for Promoting GSHP Solutions.» *geosciences*, 14 February 2018.

More-Connect. «Development and advanced prefabrication of innovative, multifunctional building envelope elements for MODular RETrofitting and CONNECTIONs.» 2019.

Rousselot, Marie. «Energy efficiency trends in buildings.» *ODYSSEE-MURE*, June 2018.

Saheb, Yamin. «Energy Transition of the EU Building Stock,,» *OpenExp Editor*, July 2016: <http://www.buildup.eu/en/practices/publications/energy-transition-eu-building-stock-unleashing-4th-industrial-revolution-0>.

Sijpheer, N. C., Borsboom, W. A., & Opstelten, I. J. «Results from first “NetZero Energy” projects in the Netherlands. Paper presented at the Sustainable Built Environment 2016:Transition Zero – SBE16, Utrecht.» 2016 .

Simona D'Oca, Annarita Ferrante, Clara Ferrer, Roberta Perneti, Anna Gralka, Rizal Sebastian, Peter op 't Veld. «Technical, Financial, and Social Barriers and Challenges in Deep Building Renovation: Integration of Lessons Learned from the H2020 Cluster Projects.» 6 December 2018.

Sosale, S., HASHEMIAN, M., GU, P. «Product Modularization for reuse and recycling.» 1997.

Tzyy-Shuh Chang, Allen C. Ward. «Conceptual robustness in simultaneous engineering: A formulation in continuous spaces.» June 1995.

Ulrich Knaack, Tillmann Klein, Marcel Bilow, Thomas Auer. *Façades: Principles of Construction*. Birkhäuser Verlag AG, 2007.

Appendices

Amsterdam HDD: 2618 (base temperature 18°C)	Existing wall U-value W/(m²K)	1.9	Current energy demand for heating of the existing wall (MJ) per m²	429.7	0.27	61	Energy savings after the implementation of the new façade system. (MJ) per m²	368.9	85%	Temperature weighting factor $\alpha = U_e A_e /$ $(U_e A_e + U_i A_i)$	0.12	New energy demand for heating after the implementation of the system (MJ) per m² (For double skin façade)	51.5	Energy savings after the implementation of the new façade system. (MJ) per m² (For double skin façade)	378.2	Percentage of improvement of the energy performance per m² after retrofitting.	88%
	Transparent surface	2.5	565.4	1.3	294	271.4	48%	0.3	169.6	395.8	70%						
Amsterdam CDD: 199 (base temperature 18°C)	Existing construction U-value W/(m²K)	1.9	Current energy demand for cooling of the existing wall (MJ) per m²	32.6	0.27	4.6	Energy savings after the implementation of the new façade system. (MJ)	28	85%	0.12	3.2	New energy demand for cooling after the implementation of the system (MJ) per m² (For double skin façade)	3.2	Energy savings after the implementation of the new façade system. (MJ)	28.7	Percentage of improvement of the energy performance after retrofitting.	88%
	Transparent surface	2.5	42.9	1.3	22.3	20.6	48%	0.3	12.8	30.1	70%						
Athens HDD: 1170 (base temperature 18°C)	Existing wall U-value W/(m²K)	1.48	Current energy demand for heating of the existing wall (MJ) per m²	149.6	0.27	27.2	Energy savings after the implementation of the new façade system. (MJ) per m²	122.4	81%	0.15	22.4	New energy demand for heating after the implementation of the system (MJ) per m² (For double skin façade)	22.4	Energy savings after the implementation of the new façade system. (MJ) per m² (For double skin façade)	126.6	Percentage of improvement of the energy performance per m² after retrofitting.	85%
	Transparent surface	5.7	576.2	2.5	252.7	323.5	56%	0.3	172.8	403.4	70%						
Athens CDD: 1168 (base temperature 18°C)	Existing construction U-value W/(m²K)	1.48	Current energy demand for cooling of the existing wall (MJ) per m²	149.3	0.27	27.2	Energy savings after the implementation of the new façade system. (MJ)	122.1	80%	0.15	22.3	New energy demand for cooling after the implementation of the system (MJ) per m² (For double skin façade)	22.3	Energy savings after the implementation of the new façade system. (MJ)	127	Percentage of improvement of the energy performance after retrofitting.	85%
	Transparent surface	5.7	575.2	2.5	252.7	323.5	56%	0.3	172.8	403.4	70%						

TEMPERATURE RANGE
ASHRAE Standard 55-2004 using PMV

LOCATION: ATHENS, -, GRC
Latitude/Longitude: 37.9° North, 23.73° East, **Time Zone from Greenwich 2**
Data Source: IWECC Data 167160 WMO Station Number, **Elevation 15 m**

LEGEND

- RECORDED HIGH - ○
- DESIGN HIGH -
- AVERAGE HIGH -
- MEAN -
- AVERAGE LOW -
- DESIGN LOW -
- RECORDED LOW - ○

- COMFORT ZONE
- SUMMER
- WINTER
- (At 50% Relative Humidity)

- DESIGN HIGH: Residential
- 1% of Hours Above
- .5% of Hours Above
- 0% of Hours Above
- DESIGN LOW: Residential
- 1% of Hours Below
- .5% of Hours Below
- 0% of Hours Below

- TEMPERATURE RANGE:
- 10 to 40 °C
- Fit to Data

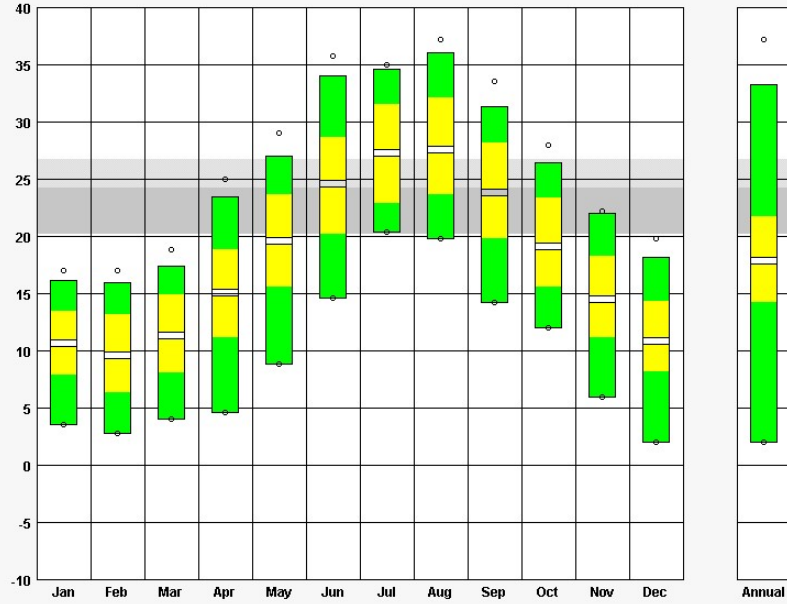

[Back](#) [Next](#)

ILLUMINATION RANGE

LOCATION: ATHENS, -, GRC
Latitude/Longitude: 37.9° North, 23.73° East, **Time Zone from Greenwich 2**
Data Source: IWECC Data 167160 WMO Station Number, **Elevation 15 m**

LEGEND

- HOURLY ILLUMINATION DAYLIT HOURS ONLY**
- RECORDED HIGH - ○
 - AVERAGE HIGH -
 - MEAN -
 - AVERAGE LOW -
 - RECORDED LOW - ○

 - RECORDED:
 - DIRECT NORMAL
 - GLOBAL HORIZONTAL (lux)

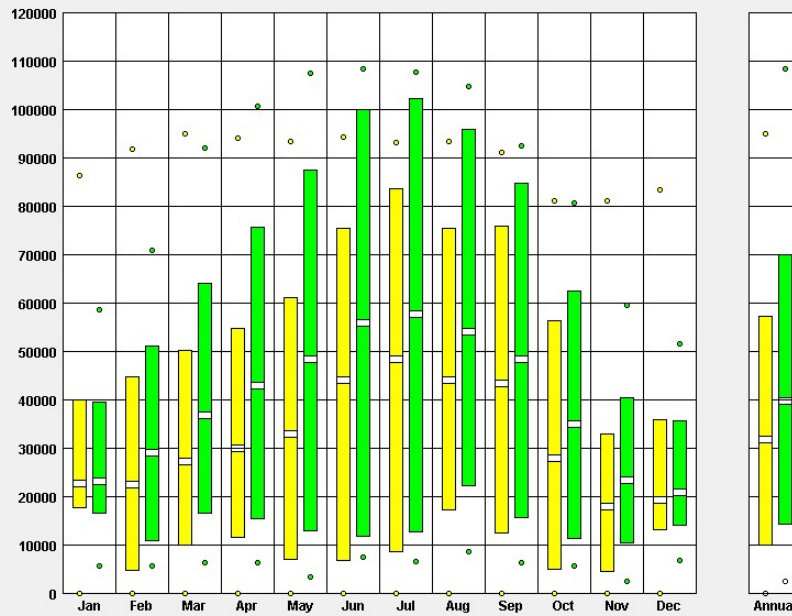

[Back](#) [Next](#)

PSYCHROMETRIC CHART
ASHRAE Standard 55-2004 using PMV

LOCATION: ATHENS, -, GRC
Latitude/Longitude: 37.9° North, 23.73° East, **Time Zone from Greenwich 2**
Data Source: IWEC Data 167160 WMO Station Number, **Elevation 15 m**

LEGEND

COMFORT INDOORS
100% COMFORTABLE
0% NOT COMFORTABLE

PLOT: COMFORT INDOORS

Hourly Daily Min/Max

All Hours Select Hours

1 a.m. through 12 a.m.

All Months Select Months

JAN through DEC

1 Month JAN Next

1 Day 1 Next

1 Hour 1 a.m. Next

TEMPERATURE RANGE:

-10 to 40 °C Fit to Data

Display Design Strategies

Show Best set of Design Strategies

DESIGN STRATEGIES: JANUARY through DECEMBER

- 20.5% 1 Comfort(1800 hrs)
- 12.9% 2 Sun Shading of Windows(1127 hrs)
- 3 High Thermal Mass(0 hrs)
- 4 High Thermal Mass Night Flushed(0 hrs)
- 5 Direct Evaporative Cooling(0 hrs)
- 7.2% 6 Two-Stage Evaporative Cooling(627 hrs)
- 4.1% 7 Natural Ventilation Cooling(362 hrs)
- 8 Fan-Forced Ventilation Cooling(0 hrs)
- 30.7% 9 Internal Heat Gain(2685 hrs)
- 10 Passive Solar Direct Gain Low Mass(0 hrs)
- 13.0% 11 Passive Solar Direct Gain High Mass(1138 hrs)
- 0.3% 12 Wind Protection of Outdoor Spaces(30 hrs)
- 13 Humidification Only(0 hrs)
- 6.0% 14 Dehumidification Only(529 hrs)
- 6.0% 15 Cooling, add Dehumidification if needed(523 hrs)
- 24.3% 16 Heating, add Humidification if needed(2133 hrs)

100.0% Comfortable Hours using Selected Strategies
(8760 out of 8760 hrs)

Comfort Zones show:
Summer clothing on right,
Winter clothing on left.

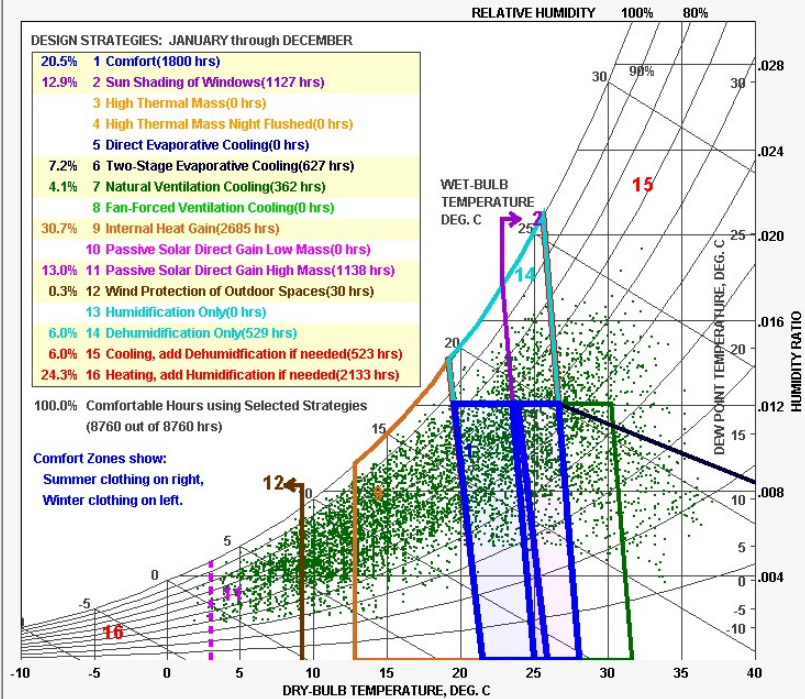

Click on Design Strategy to select or deselect.

Back Next

RADIATION RANGE

LOCATION: ATHENS, -, GRC
Latitude/Longitude: 37.9° North, 23.73° East, **Time Zone from Greenwich 2**
Data Source: IWEC Data 167160 WMO Station Number, **Elevation 15 m**

LEGEND

HOURLY AVERAGES
DAYLIT HOURS ONLY

RECORDED HIGH - ○
AVERAGE HIGH - ■
MEAN - ■
AVERAGE LOW - ■
RECORDED LOW - ○

RECORDED:
DIRECT NORMAL
GLOBAL HORIZONTAL
TOTAL SURFACE
(Wh/sq.m per hour)
THEORETICAL:

Tilted Surface Radiation Input:
0.0 Tilt degrees from Horizontal
(Vertical = 90°)
0.0 Bearing degrees from South
(South = 0°, West = +90°)
20.0 % Ground Reflectance
(20% = grass)

PLOT:
 Hourly Avg Daily Total

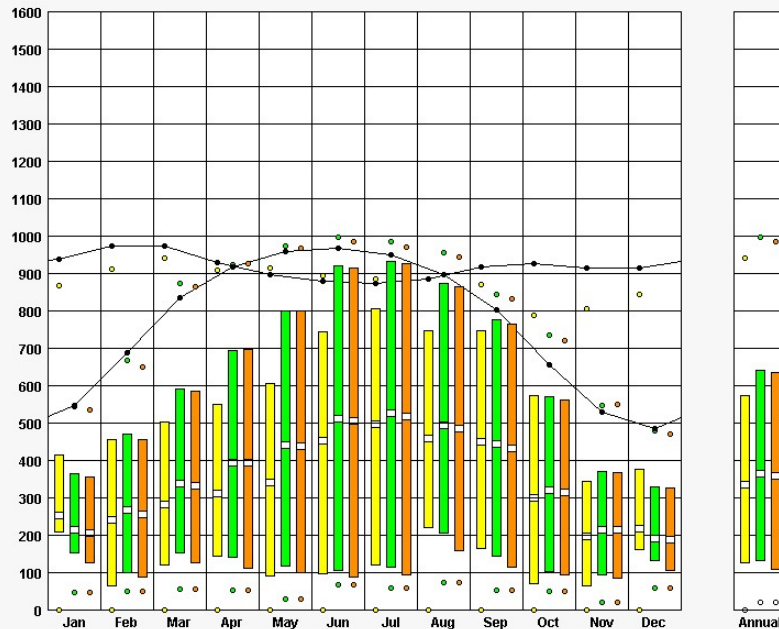

Hit ENTER to replot if you change Tilted Surface Radiation parameters.

Back Next

SUN SHADING CHART

LOCATION: ATHENS, -, GRC
Latitude/Longitude: 37.9° North, 23.73° East, **Time Zone from Greenwich 2**
Data Source: IVEC Data 167160 WMO Station Number, **Elevation 15 m**

LEGEND

- **WARM/HOT > 27°C**
(SHADE NEEDED)
90 Hours Exposed
0 Hours Shaded
- **COMFORT > 20°C**
(SHADE HELPS)
550 Hours Exposed
0 Hours Shaded
- **COOL/COLD < 20°C**
(SUN NEEDED)
1557 Hours Exposed
0 Hours Shaded

PLOT MONTHS:

WINTER SPRING

December 21 to June 21

SUMMER FALL

June 21 to December 21

Display Grid

Display Shading Calculator

Display Obstruction Elevation

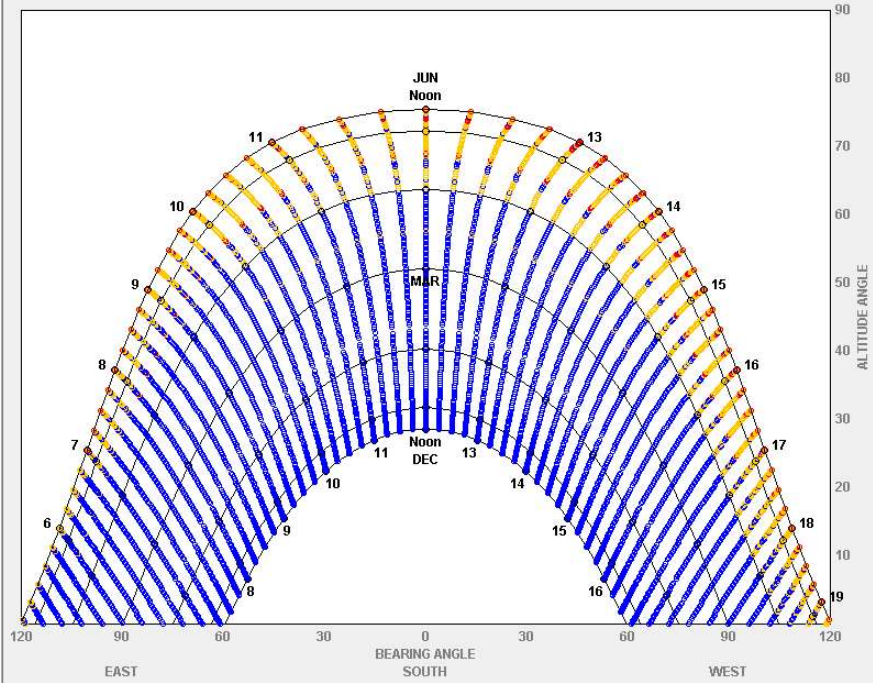

Back Next

SKY COVER RANGE

LOCATION: ATHENS, -, GRC
Latitude/Longitude: 37.9° North, 23.73° East, **Time Zone from Greenwich 2**
Data Source: IVEC Data 167160 WMO Station Number, **Elevation 15 m**

LEGEND

- Total Cloud Cover 100%
- RECORDED HIGH - ◦
- AVERAGE HIGH - ◻
- MEAN - ◻
- AVERAGE LOW - ◻
- RECORDED LOW - ◦
- Clear Skies 0

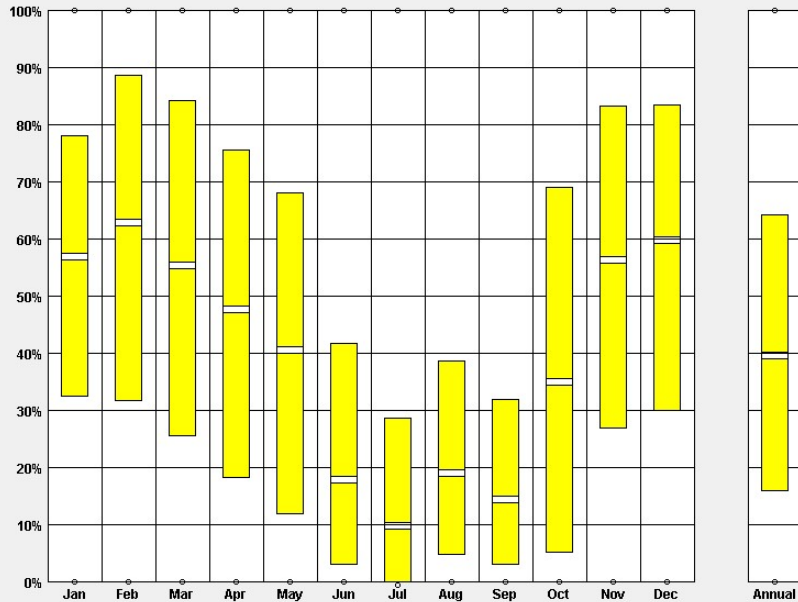

Back Next

SUN SHADING CHART

LOCATION: ATHENS, -, GRC
Latitude/Longitude: 37.9° North, 23.73° East, **Time Zone from Greenwich 2**
Data Source: IWECC Data 167160 WMO Station Number, **Elevation 15 m**

LEGEND

- **WARM/HOT > 27°C**
(SHADE NEEDED)
943 Hours Exposed
0 Hours Shaded
- **COMFORT > 20°C**
(SHADE HELPS)
684 Hours Exposed
0 Hours Shaded
- **COOL/COLD < 20°C**
(SUN NEEDED)
581 Hours Exposed
0 Hours Shaded

PLOT MONTHS:

WINTER SPRING

December 21 to June 21

SUMMER FALL

June 21 to December 21

Display Grid

Display Shading Calculator

Display Obstruction Elevation

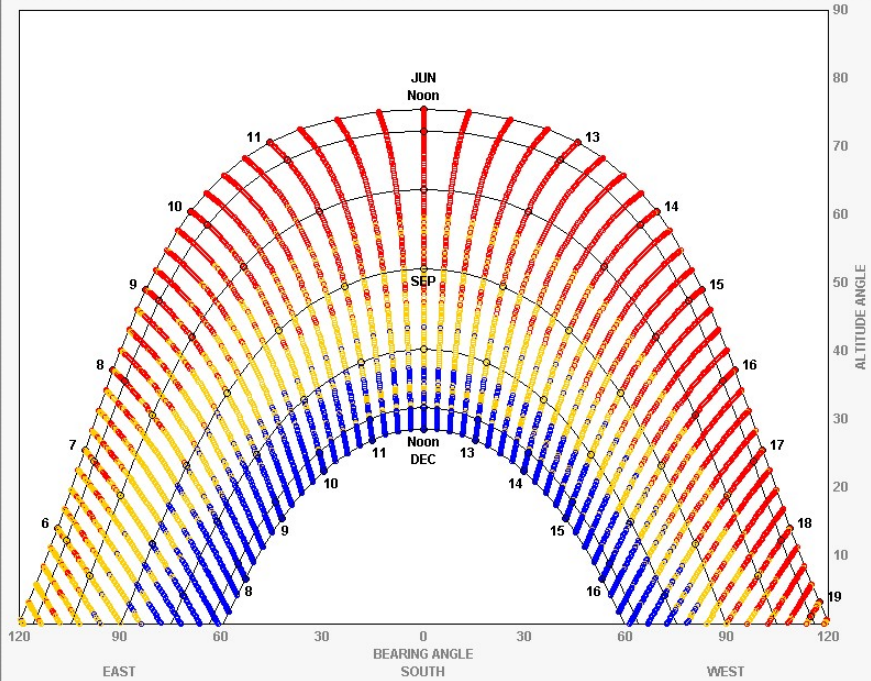

Back Next

TEMPERATURE RANGE
ASHRAE Standard 55-2004 using PMV

LOCATION: AMSTERDAM, -, NLD
Latitude/Longitude: 52.3° North, 4.77° East, **Time Zone from Greenwich 1**
Data Source: IWECC Data 062400 WMO Station Number, **Elevation -2 m**

LEGEND

- **RECORDED HIGH**
- DESIGN HIGH**
- AVERAGE HIGH**
- MEAN**
- AVERAGE LOW**
- DESIGN LOW**
- **RECORDED LOW**
- COMFORT ZONE**
- SUMMER**
- WINTER**
- (At 50% Relative Humidity)

DESIGN HIGH: Residential

- 1% of Hours Above
- .5% of Hours Above
- 0% of Hours Above

DESIGN LOW: Residential

- 1% of Hours Below
- .5% of Hours Below
- 0% of Hours Below

TEMPERATURE RANGE:

- 10 to 40 °C
- Fit to Data

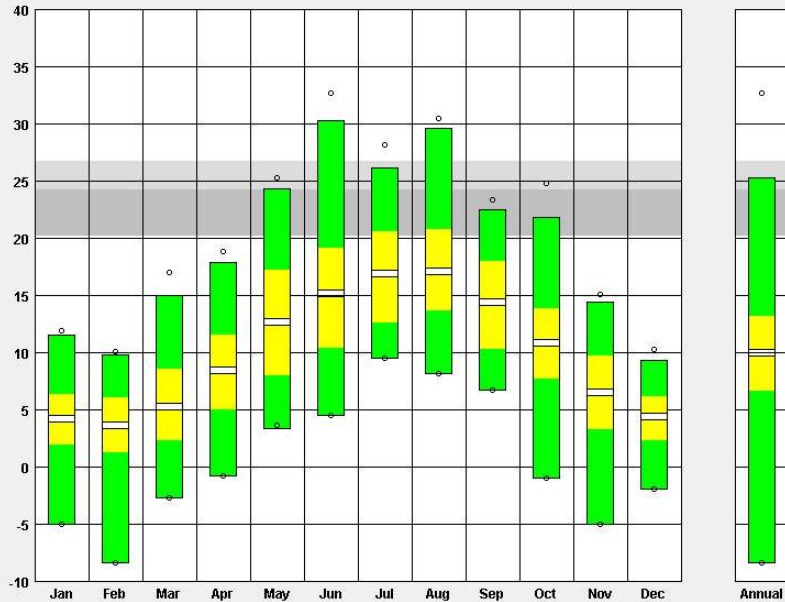

Back Next

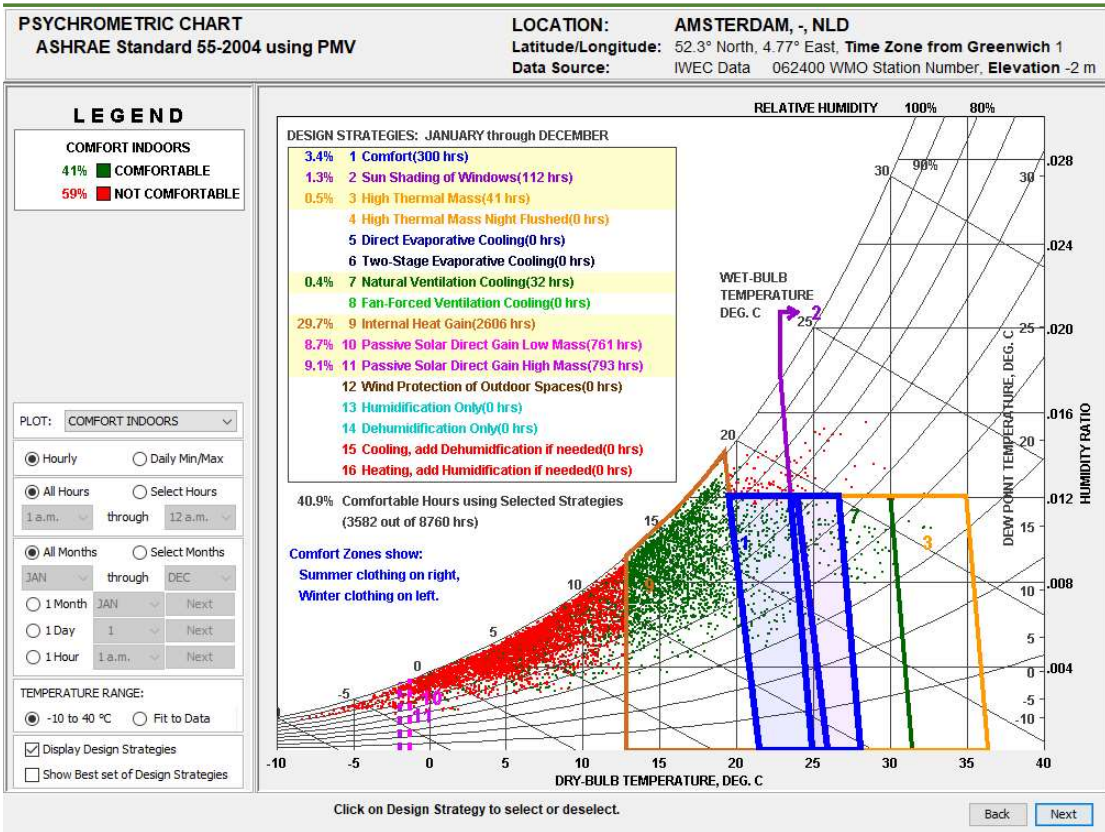
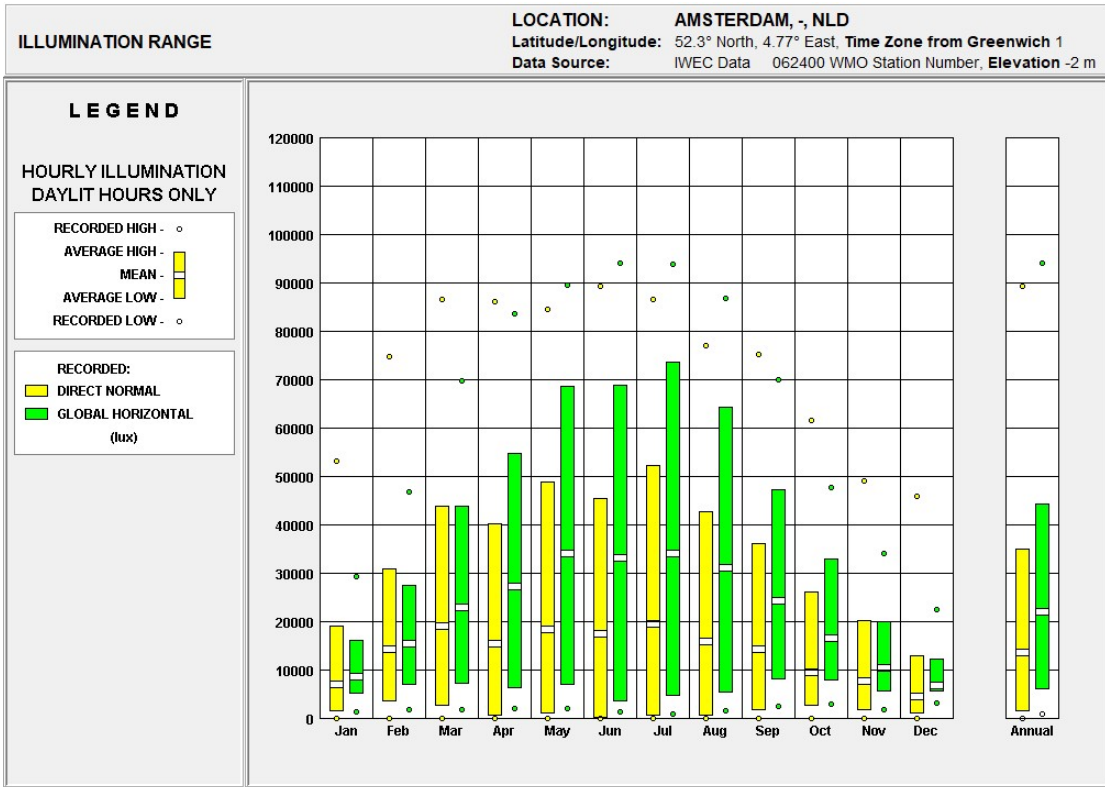

RADIATION RANGE

LOCATION: AMSTERDAM, -, NLD
Latitude/Longitude: 52.3° North, 4.77° East, **Time Zone from Greenwich 1**
Data Source: IWEC Data 062400 WMO Station Number, **Elevation -2 m**

LEGEND

**HOURLY AVERAGES
 DAYLIT HOURS ONLY**

- RECORDED HIGH - ○
 - AVERAGE HIGH - [Yellow bar]
 - MEAN - [White bar]
 - AVERAGE LOW - [Yellow bar]
 - RECORDED LOW - ○
-
- RECORDED:
 - [Yellow bar] DIRECT NORMAL
 - [Green bar] GLOBAL HORIZONTAL
 - [Orange bar] TOTAL SURFACE
(Wh/sq.m per hour)
 - [Black line with dots] THEORETICAL

- Tilted Surface Radiation Input:**
- 0.0 Tilt degrees from Horizontal
(Vertical = 90°)
 - 0.0 Bearing degrees from South
(South = 0°, West = +90°)
 - 20.0 % Ground Reflectance
(20% = grass)

- PLOT:**
- Hourly Avg
 - Daily Total

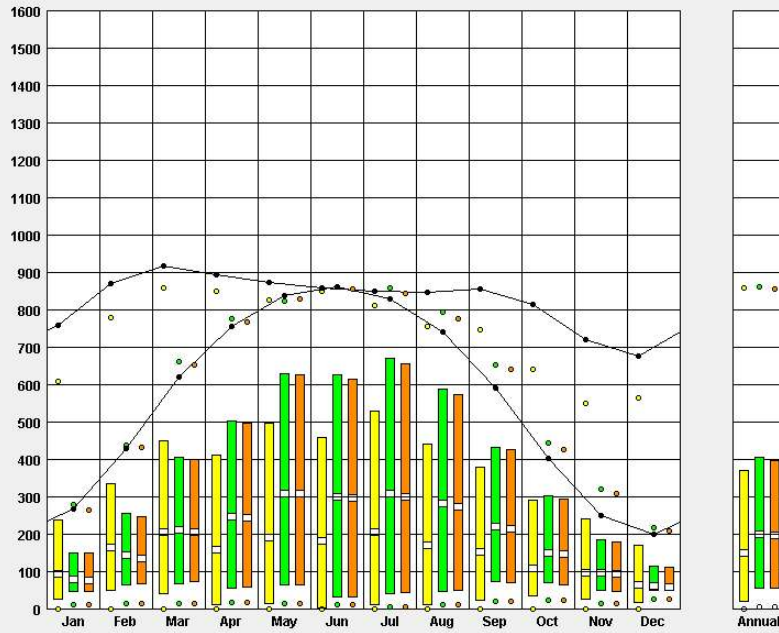

Hit ENTER to replot if you change Tilted Surface Radiation parameters.

Back Next

SKY COVER RANGE

LOCATION: AMSTERDAM, -, NLD
Latitude/Longitude: 52.3° North, 4.77° East, **Time Zone from Greenwich 1**
Data Source: IWEC Data 062400 WMO Station Number, **Elevation -2 m**

LEGEND

- Total Cloud Cover 100%
- RECORDED HIGH - ○
- AVERAGE HIGH - [Yellow bar]
- MEAN - [White bar]
- AVERAGE LOW - [Yellow bar]
- RECORDED LOW - ○
- Clear Skies 0

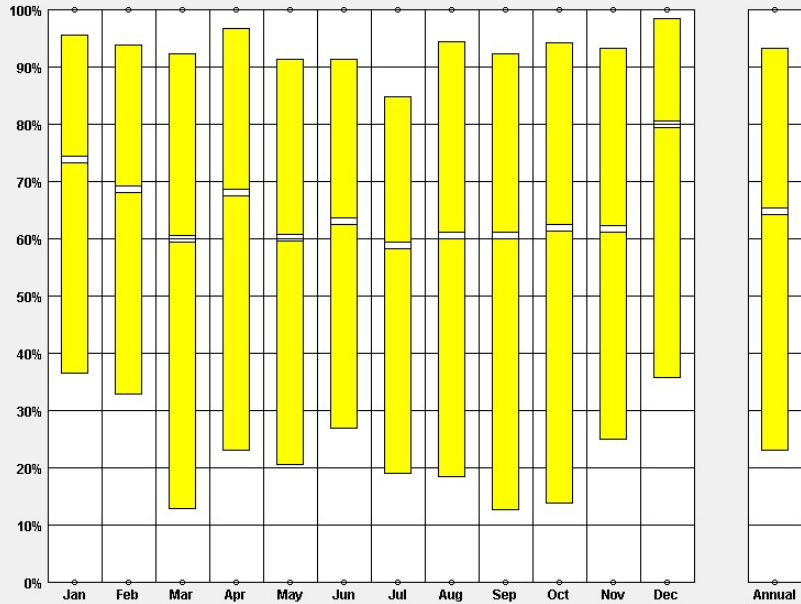

Back Next

