

'The Public Fibre'

The entering of Culturalfication within the Public Realm



Content

Research

-Field of interest

Masterplan

-Urban Scene

-Design Rules

Design

-Inspiration

-Program

-Plans (Isometrics)

-Materialisation

Sustainability

-Summer

-Winter

-Ventilation

-Water Re-use

-Energy sufficiency

Construction

-Bearing principle/1:50

-Detailing concepts 1:10

Research

Research

Field of Interest



Research

Field of Interest



Research

Field of Interest



Research

Rotterdam 1965



Research

Rotterdam 1990



Research

Rotterdam 2011



0%
NOT WESTERN →

100%

9-205

Research

Rotterdam 2025

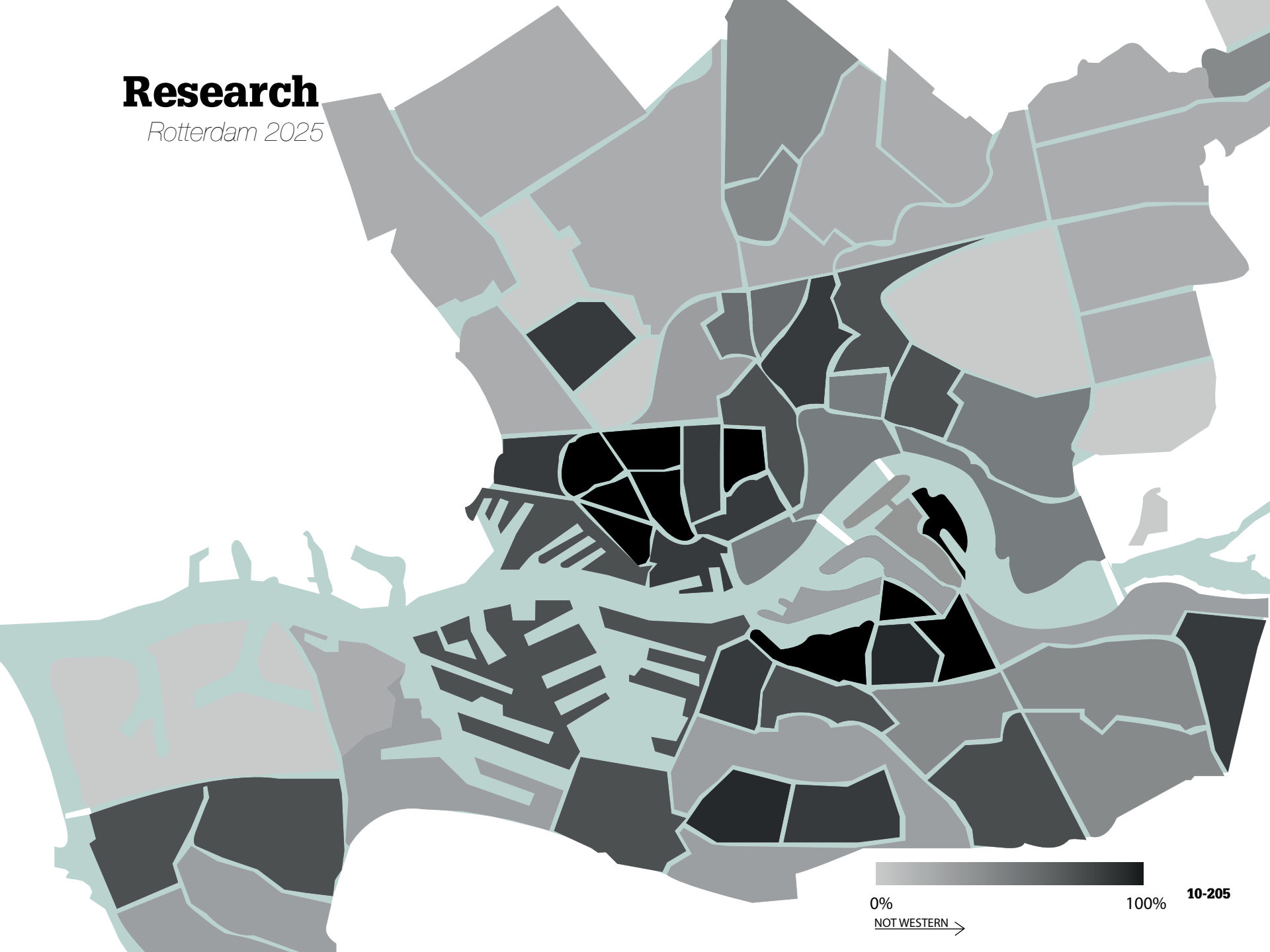

0% 100% NOT WESTERN →

10-205

**THIS PHENOMENON OF MORE AND MORE CULTURES ISIDE A
DENSE SOCIETY IS WHAT I LIKE TO CALL**

'CULTURALFICATION'

What impact has this 'culturalfication' on the public realm of the city?

Research

Location Cool

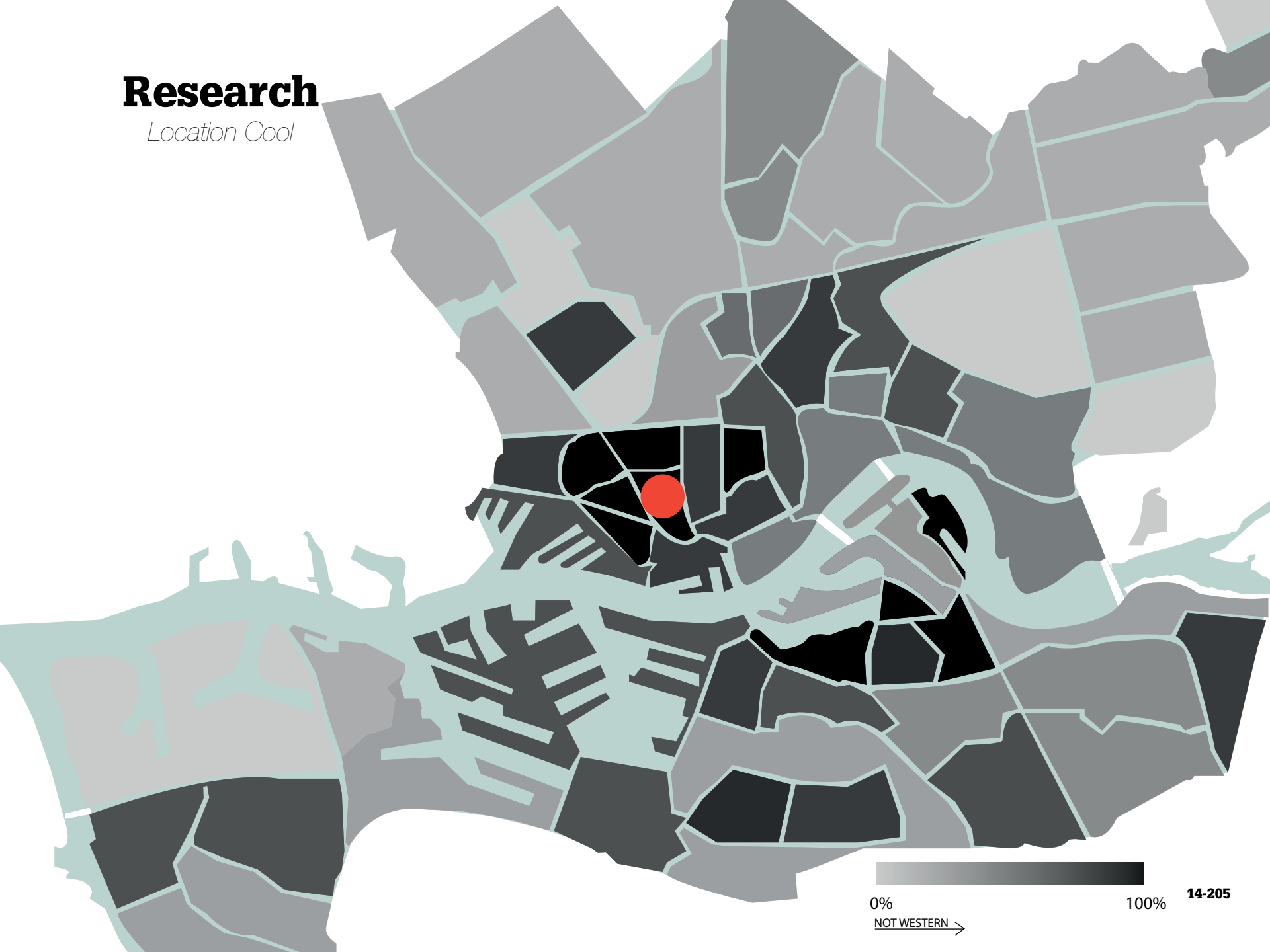

0%

NOT WESTERN →

100%

14-205

Research

Location Cool



Research

Location Cool

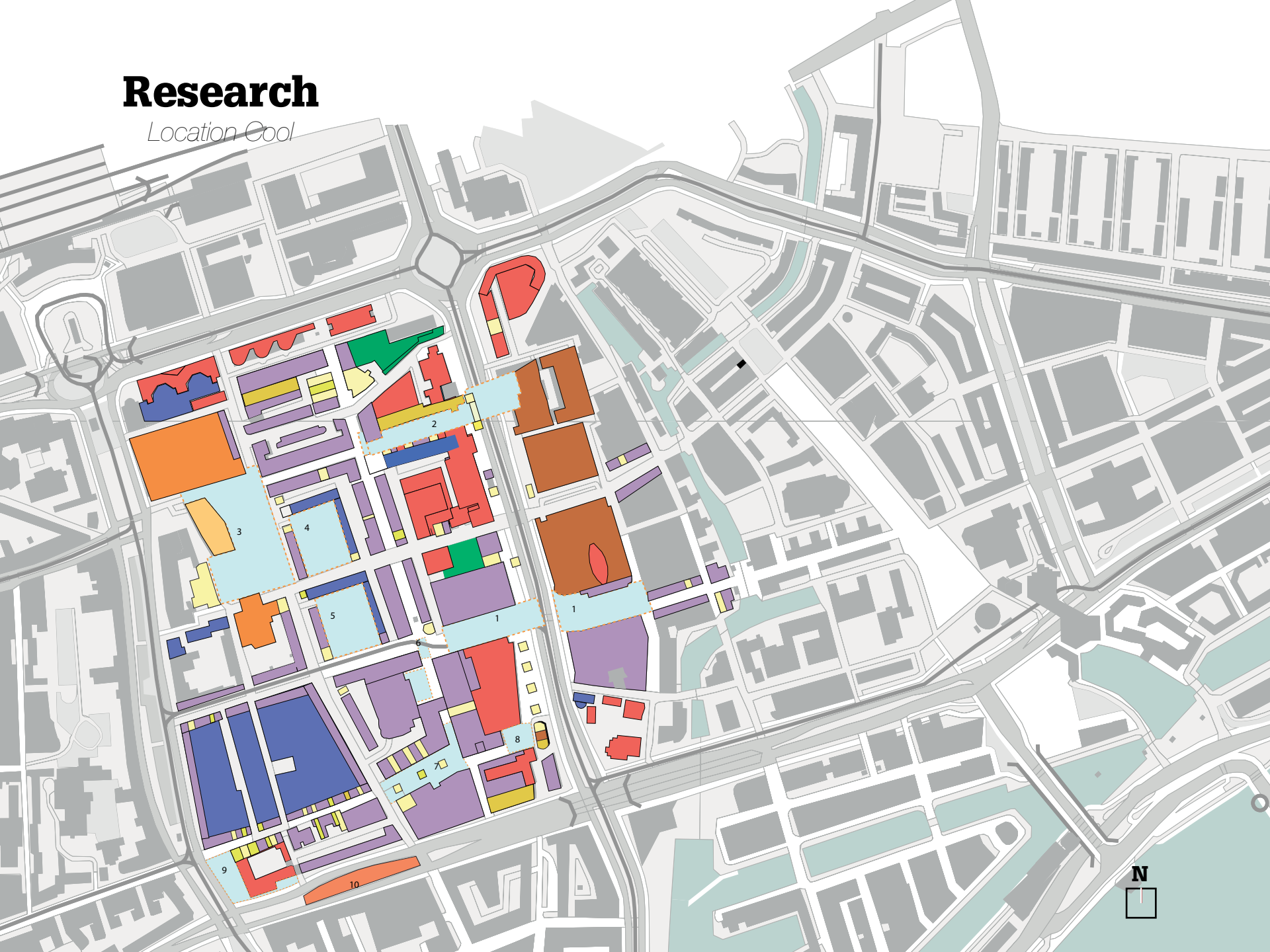

Research

Location Cool

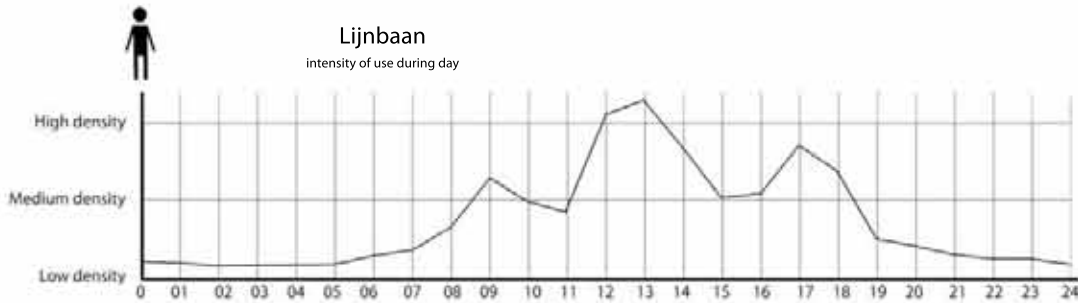

Lijnbaan
potential hours of use

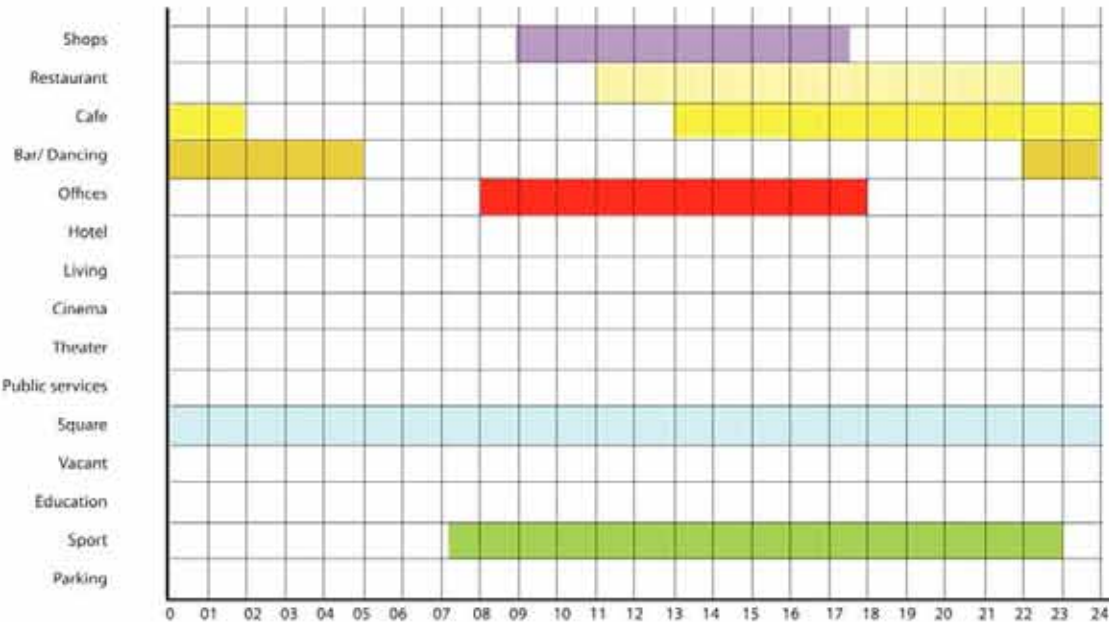

total present in area

weekday's



usage per function per ethnic group during daytime in total



usage per function per ethnic group during daytime in the public domain



usage per function per ethnic group during nighttime in the public domain

	Dutch	Maroccans	Turkish	Surinamese
Shops	15,00%	11,50%	10,00%	13,50%
Restaurant	1,80%	1,13%	1,13%	0,95%
Cafe	0,43%	0,28%	0,16%	0,13%
Bar/ Dancing	1,68%	0,51%	0,42%	0,39%
Offices	26,97%	1,24%	0,93%	1,86%
Hotel	0,00%	0,00%	0,00%	0,00%
Living	0,00%	0,00%	0,00%	0,00%
Cinema	0,00%	0,00%	0,00%	0,00%
Theater	0,00%	0,00%	0,00%	0,00%
Public services	0,00%	0,00%	0,00%	0,00%
Square	2,16%	2,43%	2,34%	2,07%
Vacant	0,00%	0,00%	0,00%	0,00%
Education	0,37%	0,16%	0,21%	0,26%
Parking	0,74%	0,32%	0,42%	0,52%
total present in area	48,41%	17,25%	15,19%	19,16%

	Dutch	Maroccans	Turkish	Surinamese
Shops	22,50%	17,25%	15,00%	20,25%
Restaurant	2,16%	1,35%	1,35%	1,14%
Cafe	0,43%	0,28%	0,16%	0,13%
Bar/ Dancing	1,68%	0,51%	0,42%	0,39%
Offices	0,00%	0,00%	0,00%	0,00%
Hotel	0,00%	0,00%	0,00%	0,00%
Living	0,00%	0,00%	0,00%	0,00%
Cinema	0,00%	0,00%	0,00%	0,00%
Theater	0,00%	0,00%	0,00%	0,00%
Public services	0,00%	0,00%	0,00%	0,00%
Square	3,12%	3,51%	3,38%	2,99%
Vacant	0,00%	0,00%	0,00%	0,00%
Education	0,74%	0,32%	0,42%	0,52%
Parking	0,74%	0,32%	0,42%	0,52%
total present in area	30,63%	23,22%	20,73%	25,42%

	Dutch	Maroccans	Turkish	Surinamese
Shops	0,00%	0,00%	0,00%	0,00%
Restaurant	7,56%	4,73%	4,73%	3,99%
Cafe	0,86%	0,56%	0,32%	0,26%
Bar/ Dancing	8,40%	2,55%	2,10%	1,95%
Offices	0,00%	0,00%	0,00%	0,00%
Hotel	0,00%	0,00%	0,00%	0,00%
Living	0,00%	0,00%	0,00%	0,00%
Cinema	0,00%	0,00%	0,00%	0,00%
Theater	0,00%	0,00%	0,00%	0,00%
Public services	0,00%	0,00%	0,00%	0,00%
Square	13,20%	14,85%	14,30%	12,65%
Vacant	0,00%	0,00%	0,00%	0,00%
Education	2,59%	1,12%	1,47%	1,82%
Parking	2,59%	1,12%	1,47%	1,82%
total present in area	32,61%	23,81%	22,92%	20,67%

Research

Location Cool



Plan

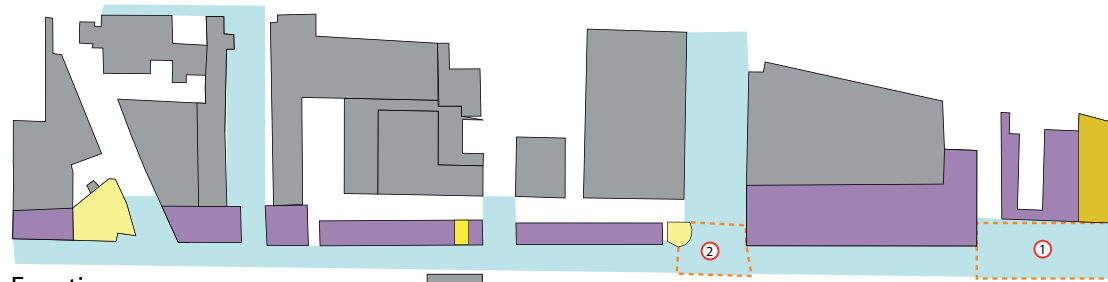

Function (facade view)

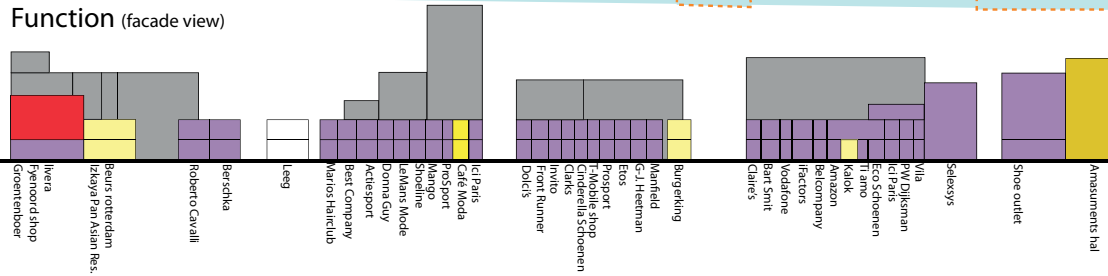

Lijnbaan facing East

Lijnbaan

Kind of use

Local ■ Not-Local ■



Percentage Public Functions



Research

Program research

PERCENTAGE USE OF PUBLIC FUNCTION EACH CULTURE

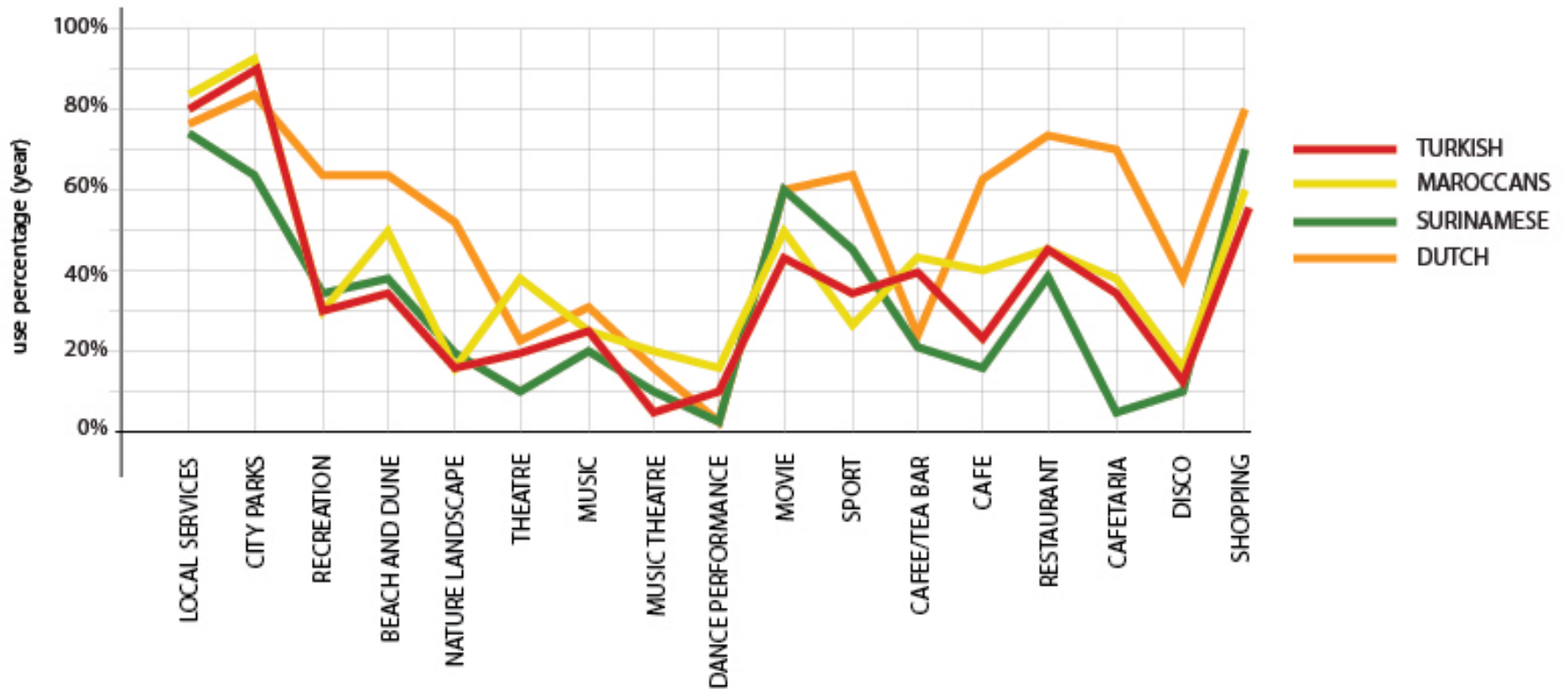







Research

Program research

PERCENTAGE USE OF PUBLIC FUNCTION EACH CULTURE

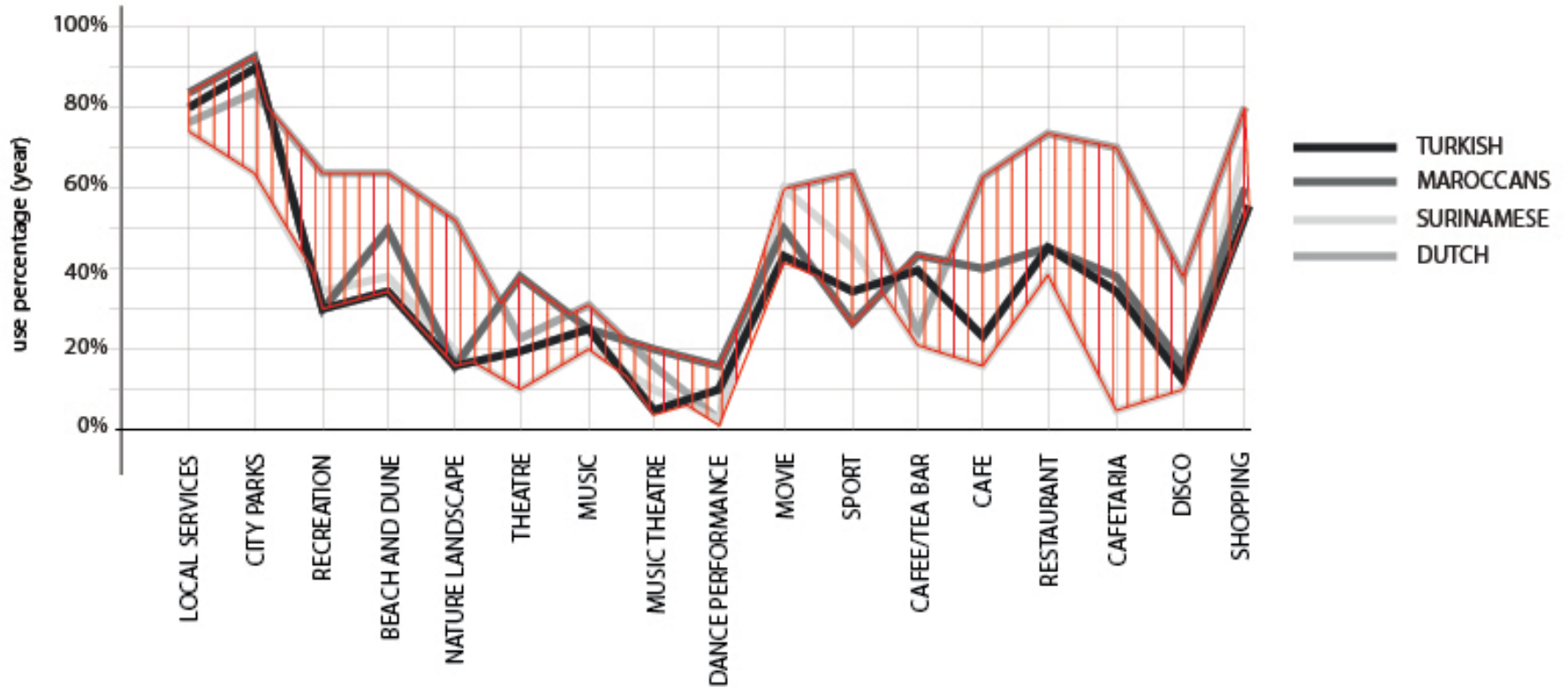

Research

Program research

SURFACE AREA USE OF PUBLIC FUNCTION

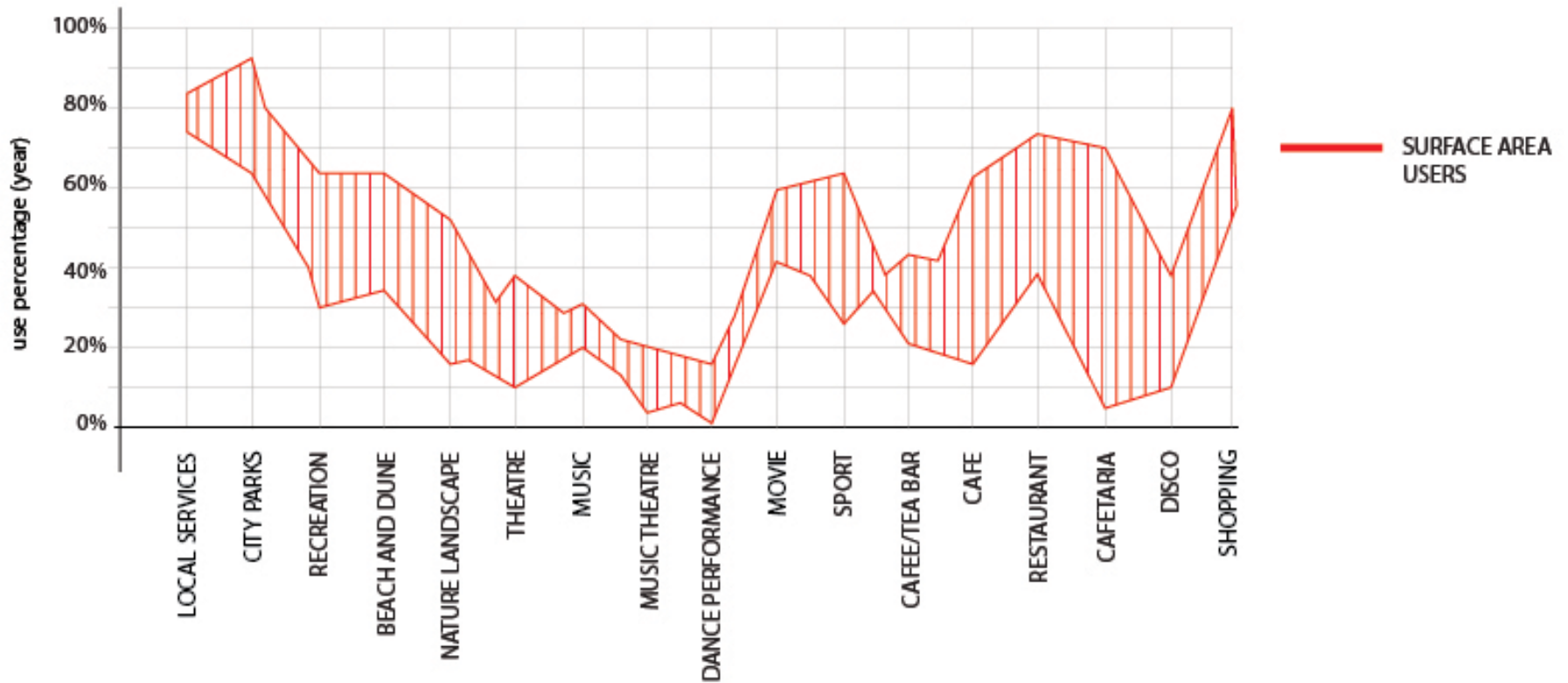

Research

Program research

SIMILAR USE OF PUBLIC FUNCTION

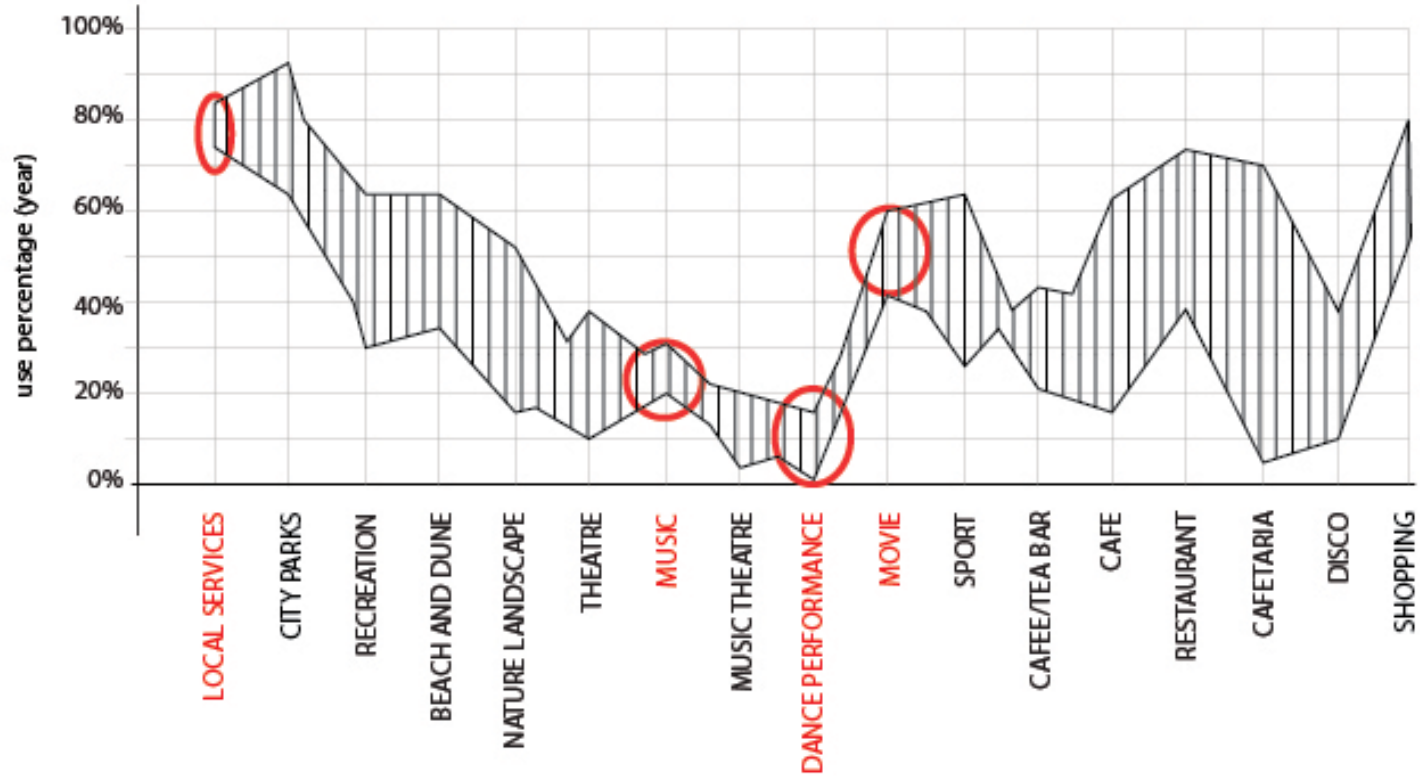

Questionnaire

Voice of the users

90% notifies a cultural diversity within the center

Questionnaire

Voice of the users

90% notifies a cultural diversity within the center
45% does that by the diversity people and only 15% by functions

Questionnaire

Voice of the users

90% notices a cultural diversity within the center
45% does that by the diversity people and only 15% by functions
65% sees this 'Culturalfication' as positive and feels safe

Questionnaire

Voice of the users

90% notices a cultural diversity within the center
45% does that by the diversity people and only 15% by functions
65% sees this 'Culturalfication' as positive and feels safe

**Shopping and Eating are the most cultural influenced and used by
the society**

Questionnaire

Voice of the users

90% notices a cultural diversity within the center
45% does that by the diversity people and only 15% by functions
65% sees this 'Culturalfication' as positive and feels safe

Shopping and Eating are the most cultural influenced and used by the
society

90% finds that the society should be open for new cultures

Questionnaire

Voice of the users

90% notices a cultural diversity within the center
45% does that by the diversity people and only 15% by functions
65% sees this 'Culturalfication' as positive and feels safe

Shopping and Eating are the most cultural influenced and used by the
society

90% finds that the society should be open for new cultures

People miss green, outside activities and public atmosphere

Research

City Center



N



1-20

Research

City Center

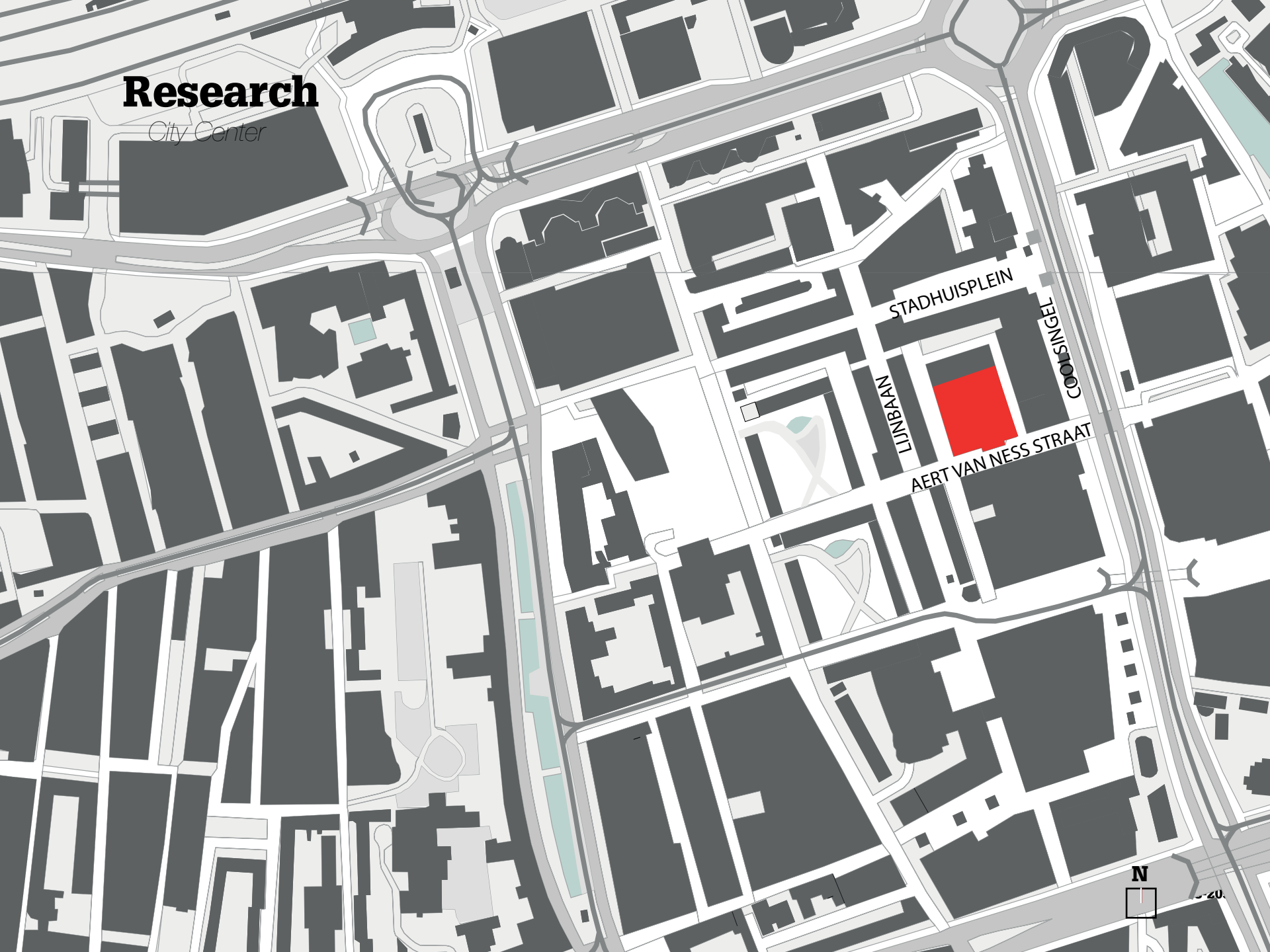

STADHUISPLEIN

LINBAN

COORNISDEEL

AERT VAN NESS STRAAT

N



1:20

Research

Location

The Location is bordered by 4 divers streets

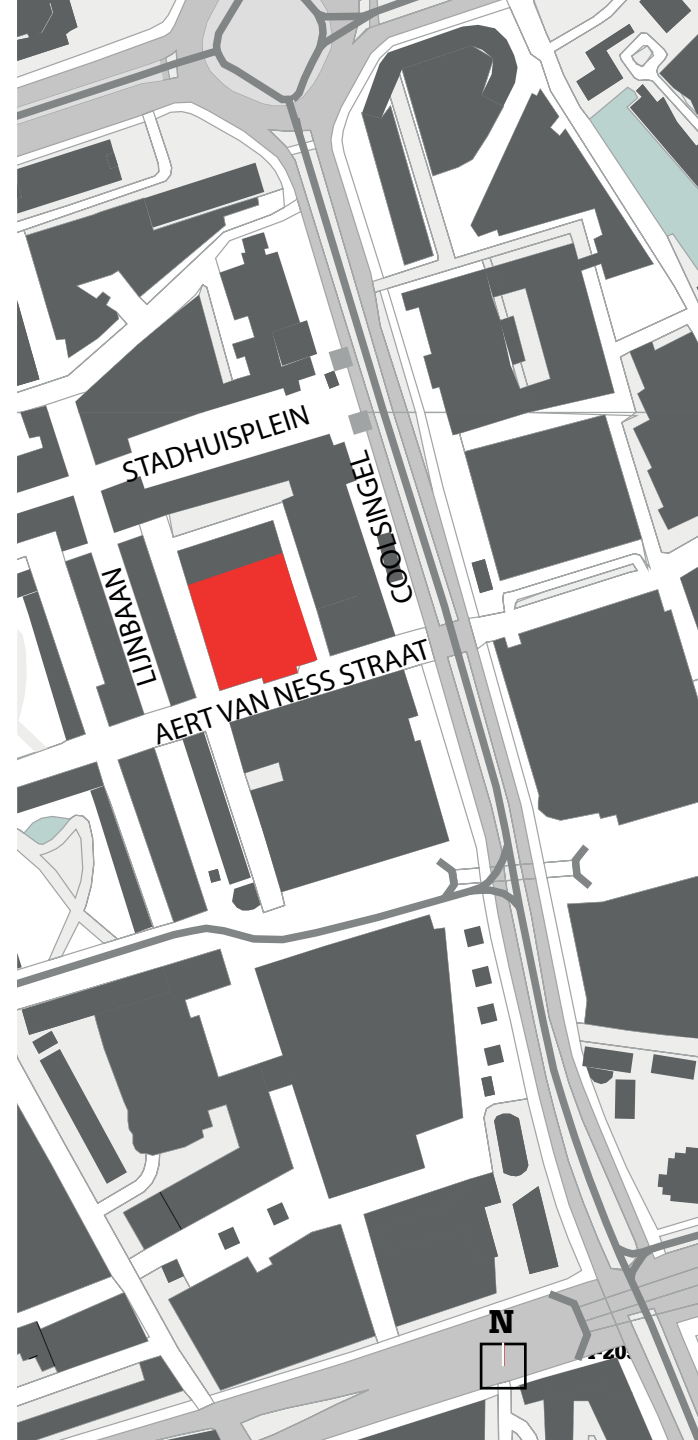

Research

Location

The Location is bordered by 4 divers streets

The Lijnbaan

It is a busy shopping street, and only that. Many stores are international known and some buildings are vacant.

very less restaurants or bars are to be found

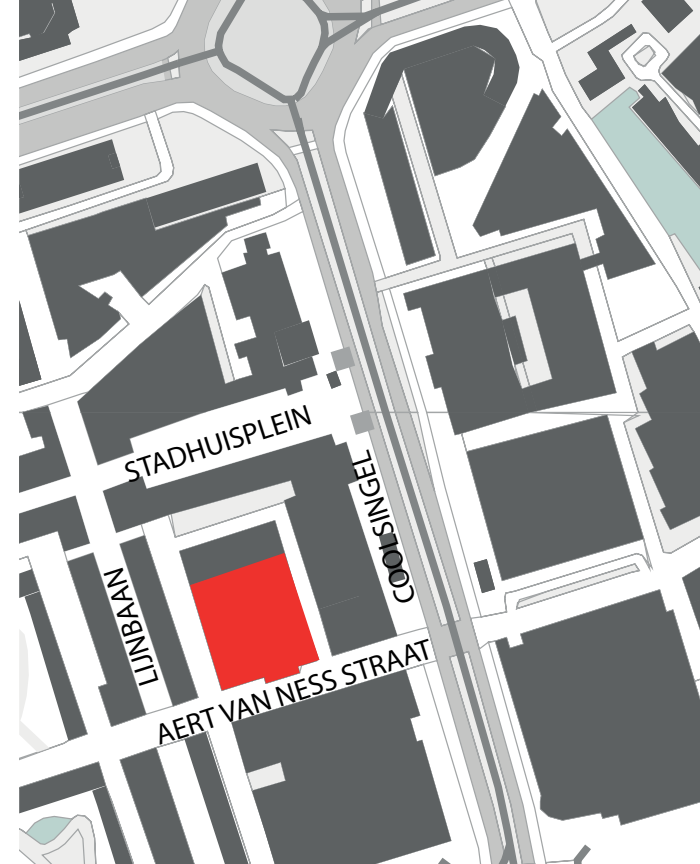

Research

Location

The Location is bordered by 4 diverse streets

The Lijnbaan

It is a busy shopping street, and only that. Many stores are internationally known and some buildings are vacant.

Very few restaurants or bars are to be found.

At night the atmosphere changes and becomes totally empty with **no use at all.**

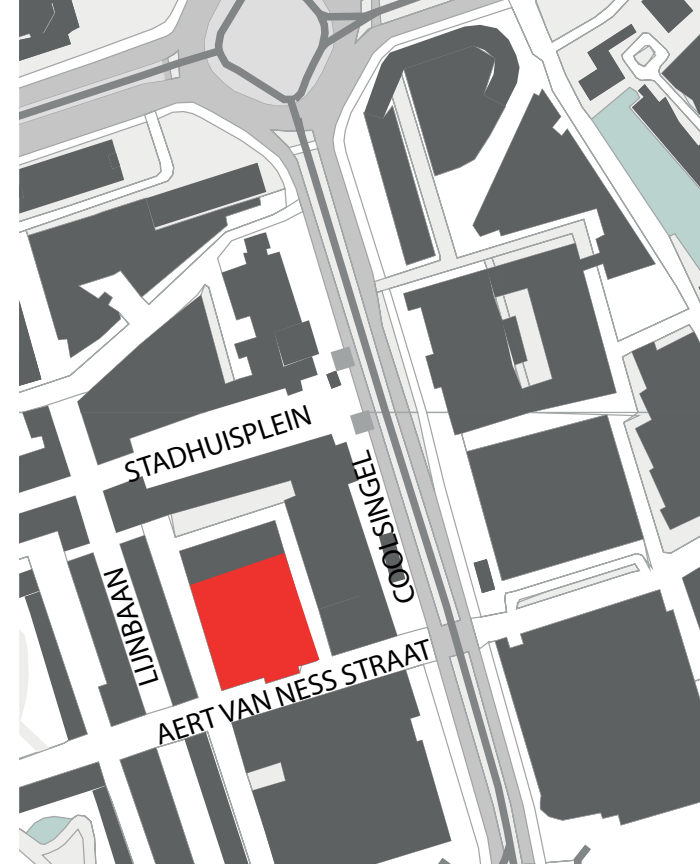

Research

Location

The Location is bordered by 4 divers streets

The Aert van Nessesstraat

Main connection between the Lijbaan and the old Meent.

No further use of the street.
Street gives acces to a parkinggarage and to office buildings.

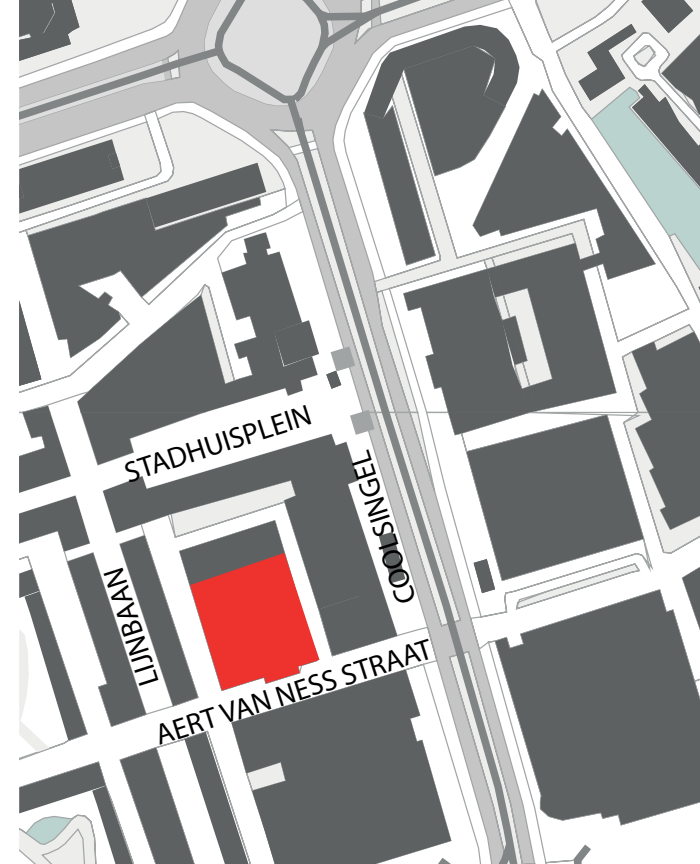

Research

Location

The Location is bordered by 4 diverse streets

The Coolsingel

Mainly fast traffic and big office buildings
Small restaurants and shops along the pedestrian sidewalk.

Crossings with the Aert van Ness and the meent
and with the Beurstraverse.

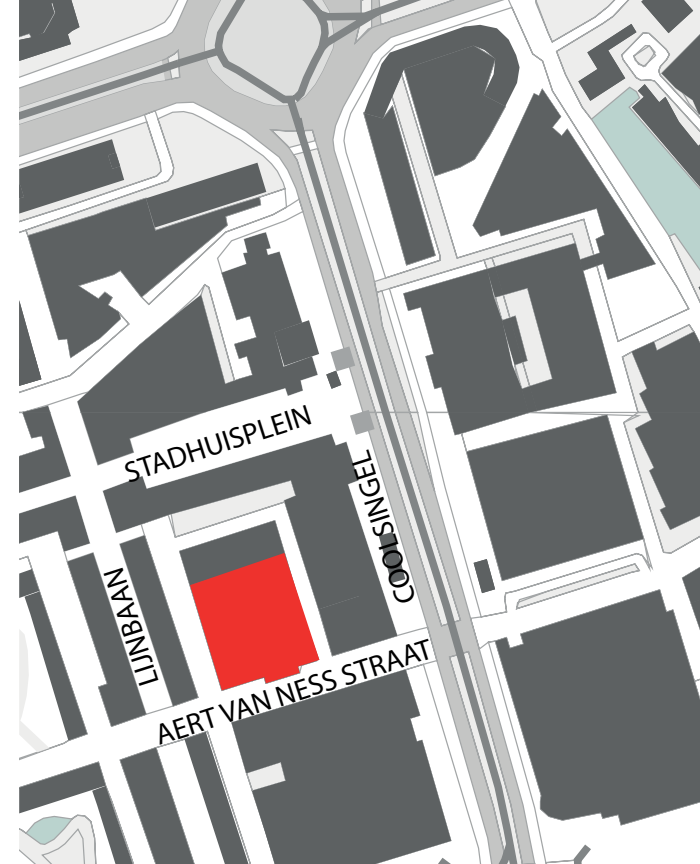

Research

Location

The Location is bordered by 4 diverse streets

Stadhuisplein

Mainly restaurants and bars

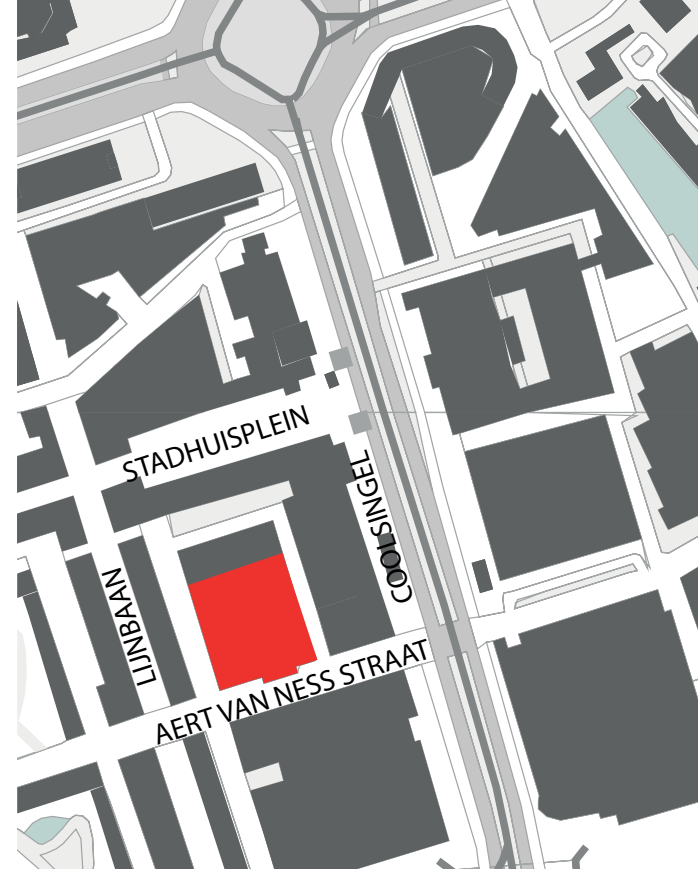

Research

Location Conclusions

Research conclusions

- Very different atmosphere daytimes and night-times.
- Rotterdam has a very multicultural society but there is no interaction
- Cool is a functionally fragmented district
- Unsafe feeling, no night activity, thus no social control
- No awareness of one another
- Surrounding streets very different atmospheres, no connection
- Mainly non local use
- **No central point to stay**

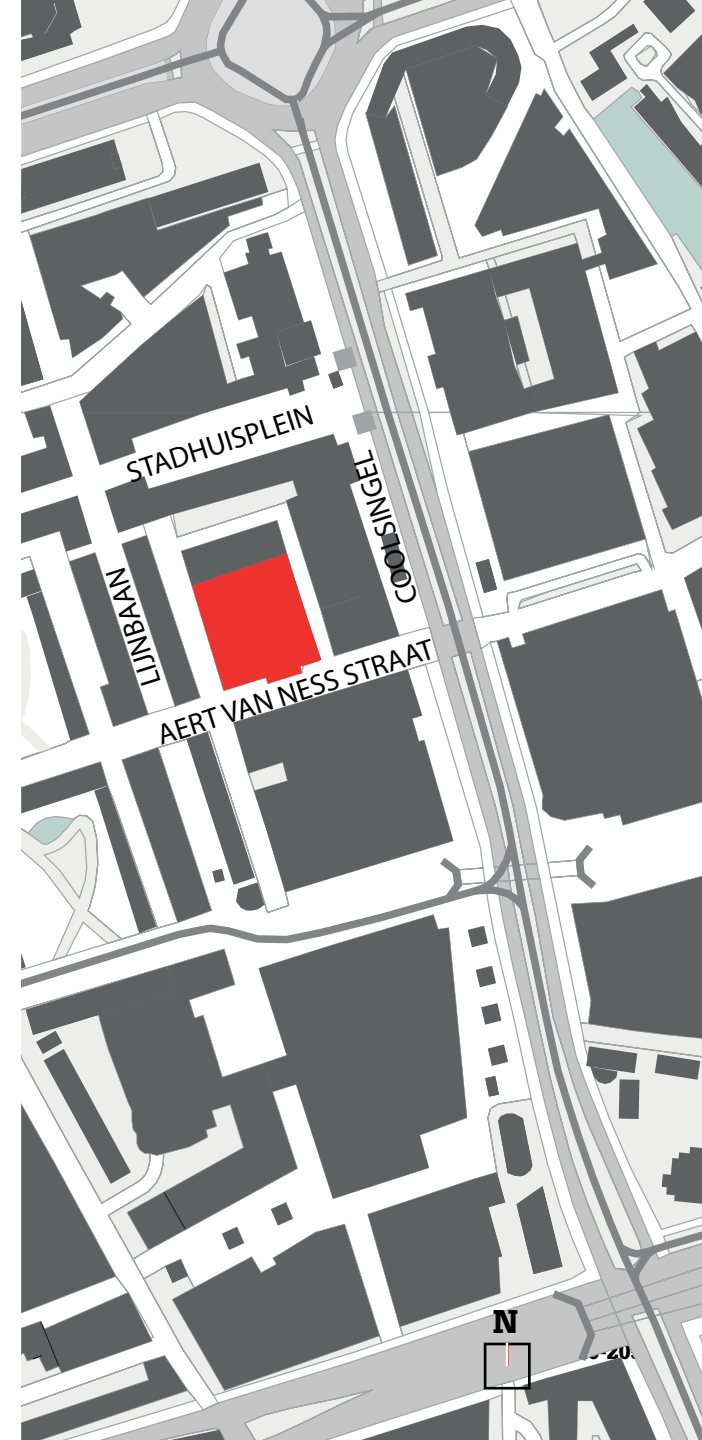

Research

Location Opportunities

Research Opportunities

- Implementing functions that stimulate a more 24 hour use
- **Create a place to meet and hang out**
- Stimulate local use for more social awareness
introduce a variety of functions to attract more
diversity of people
- Make connection with surroundings

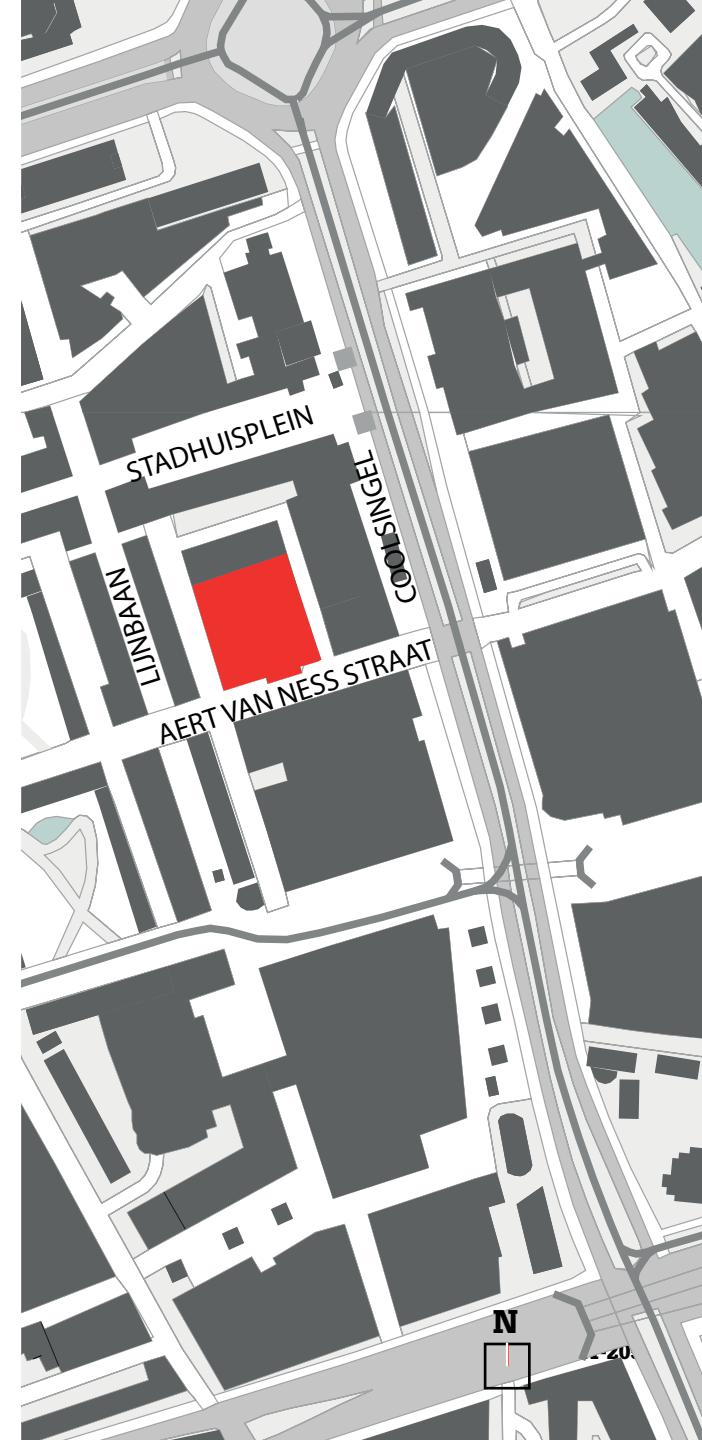

Masterplan

Masterplan

Parameters

Masterplan parameters

- Implementing functions that stimulate a more 24 hour use
- **Create a place to meet and hang out**
- **Stimulate local use for more social awareness**
- Introduce a variety of functions to attract more diversity of people
- Make connection with surroundings
- **Stimulate multicultural mix**
- Respect for existing buildings

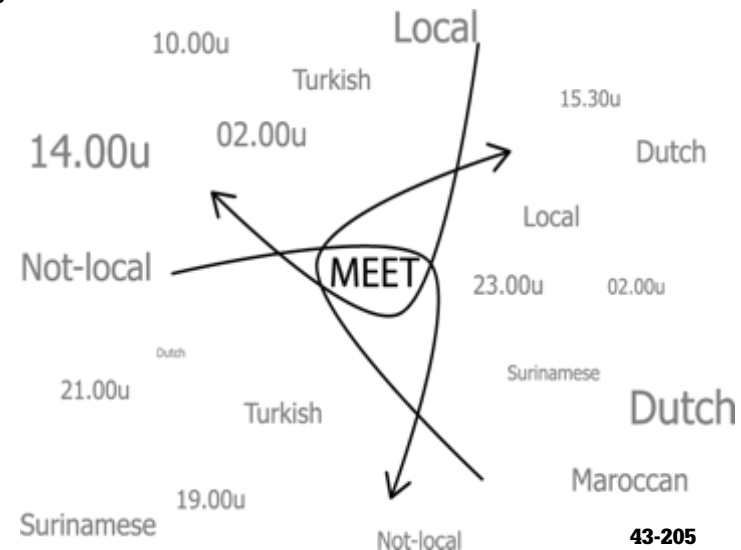

Masterplan

Concept

Important to make translation of our research on multicultural use into our concept.

We don't want to put emphasis on the cultural differences ..



Masterplan

Concept

but also look at things that could bind. Connect!
How can we make people more aware of one another? .

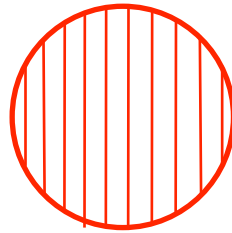

Masterplan

Concept

Every Culutre has his own expression in:

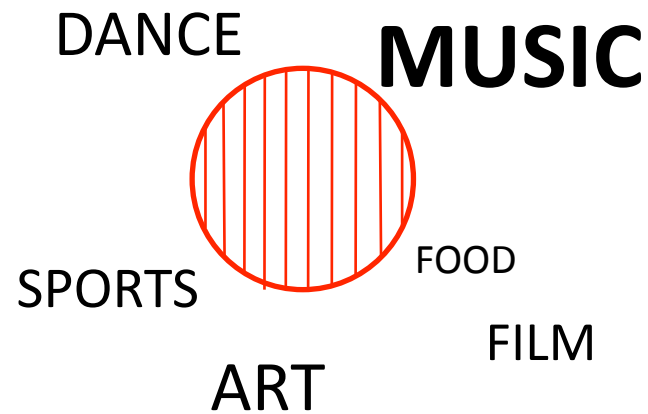

Masterplan

Concept

A Central 'stage' where every cultural expression creates awareness for its visitors.



Masterplan



Masterplan



N



0-20

Masterplan

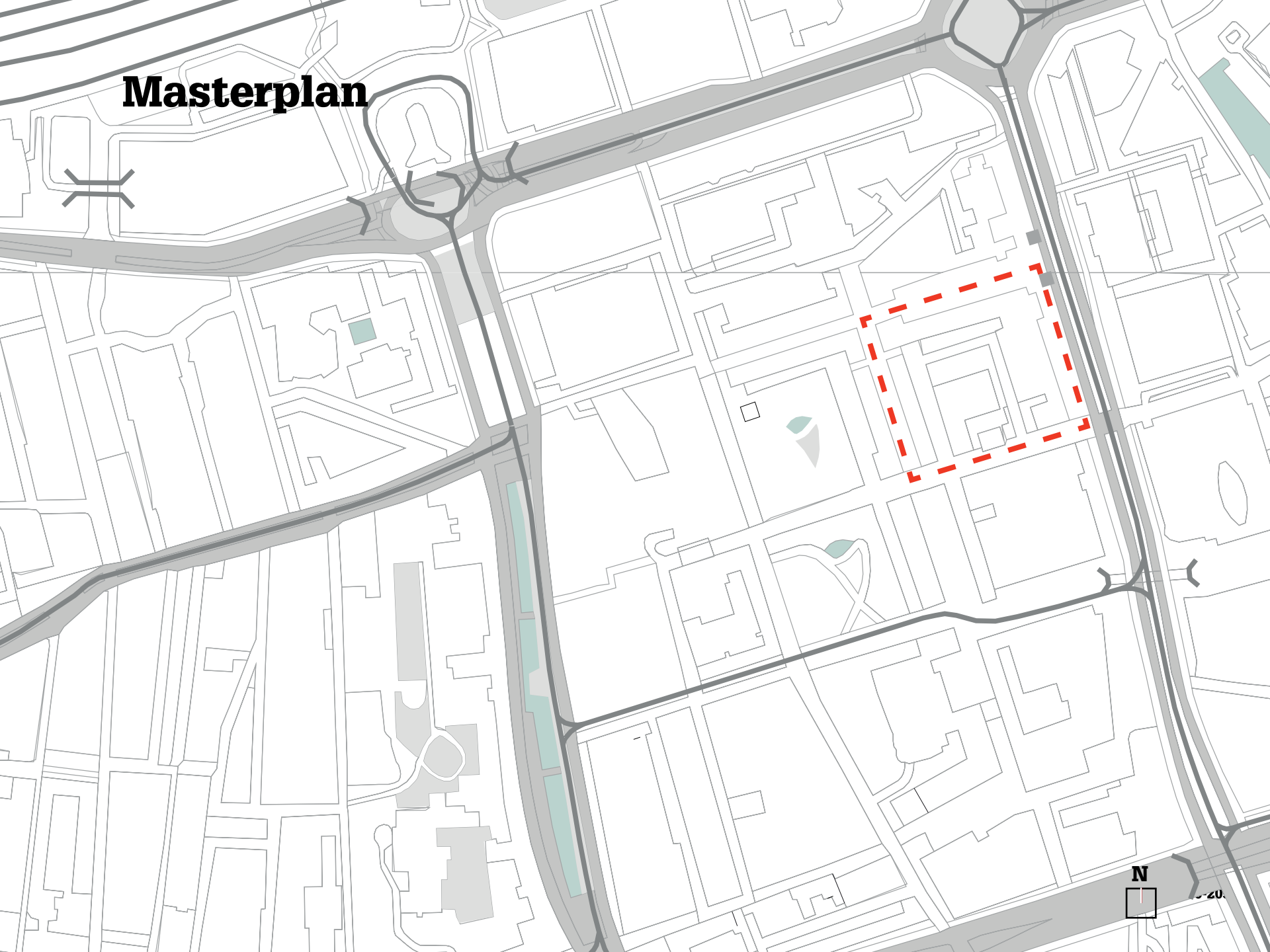

N

20

Masterplan

Urban Scene

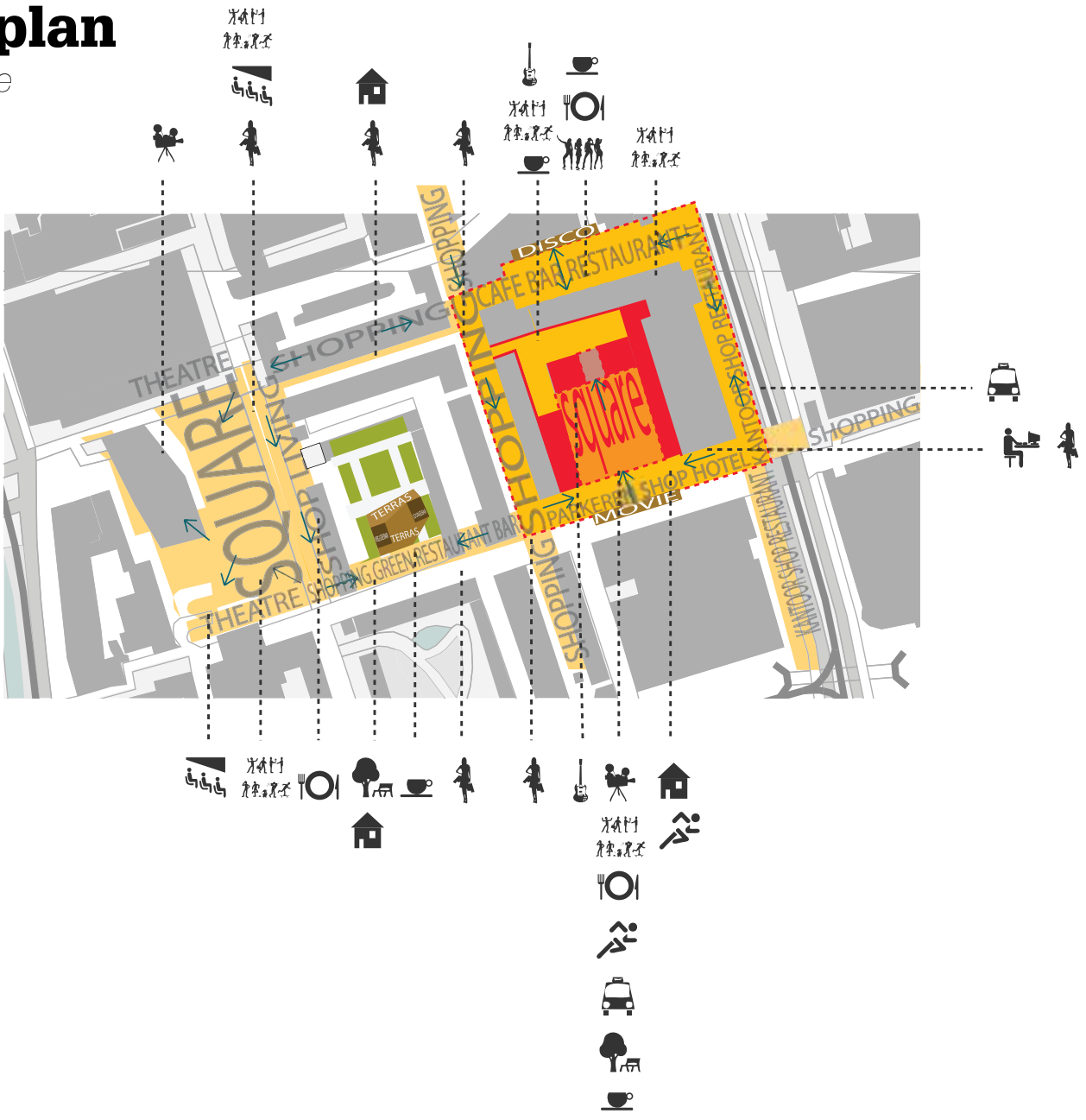

Masterplan

Program

- 1. The surrounding streets will be supported by the project.
 - More diversity
 - More local users
 - More users at different times



Masterplan

Designrules

The streams of congestion will be connected by the public and private functions on the site. So that they **uncounsiouly get consious**. The intention of the concept is that these streams are becoming aware of each other by placing them strategically by **place and time**.

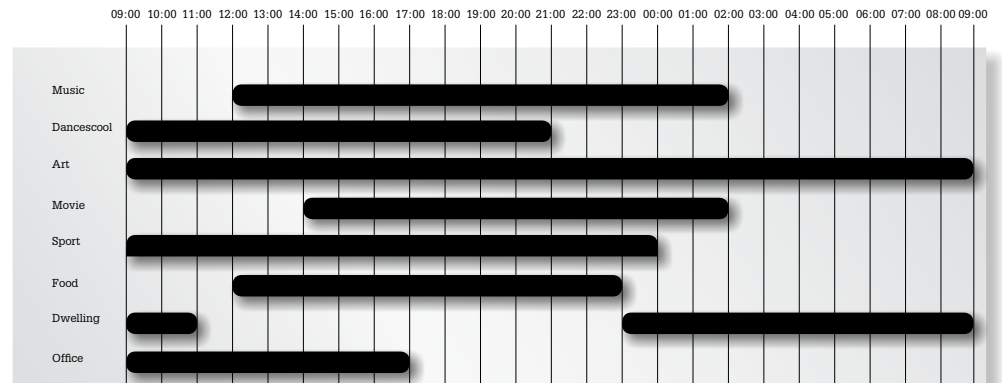
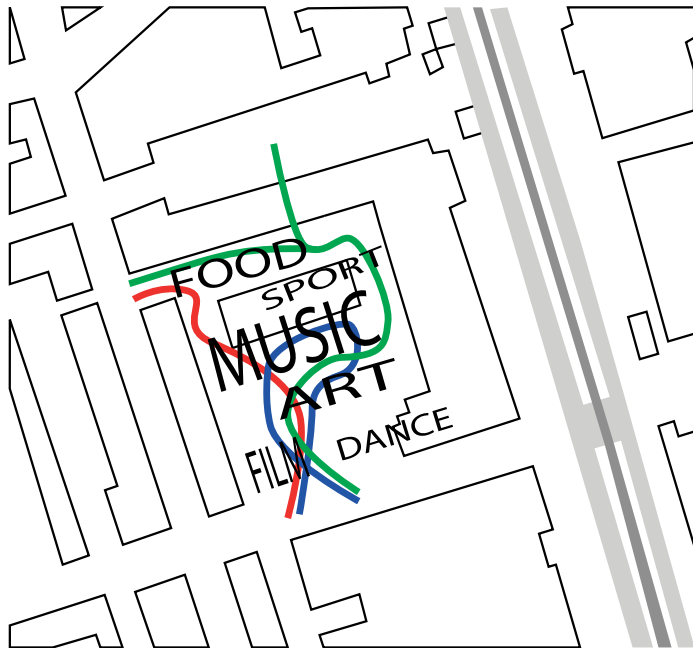

Masterplan

Designrules

A public space to meet, interact, show, express and become aware.

- Open for everyone, at all times
- A central point
- A square where cultural expression determines its sphere

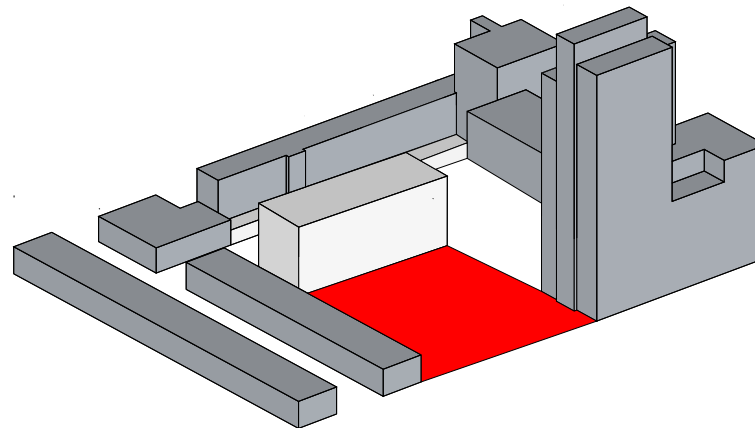

Masterplan

Designrules

A Square is defined by its surroundings



Use of existing buildings

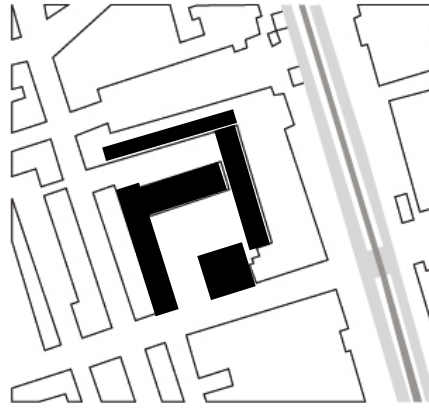

Use of surrounding

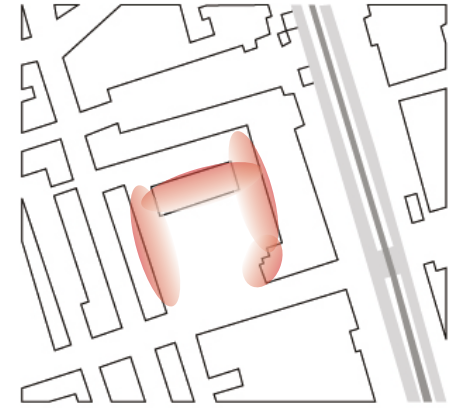

Existing access points are used or enlarged

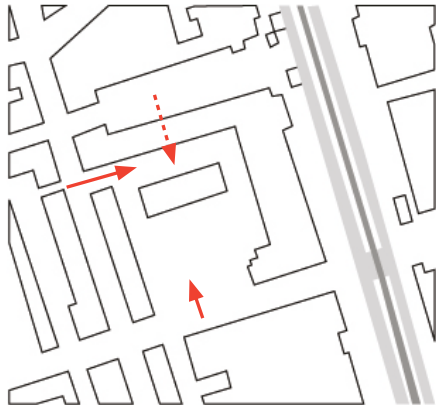

Respect for the monumental SKVR building



Buildings heights should be respected

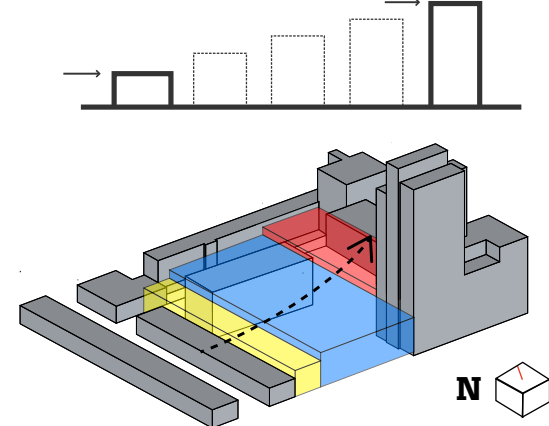

Masterplan

Designrules

In every direction a cultural expression can be displayed.
Sometimes a dance performance, sometimes a concert or sometimes
a movie determine the sphere.

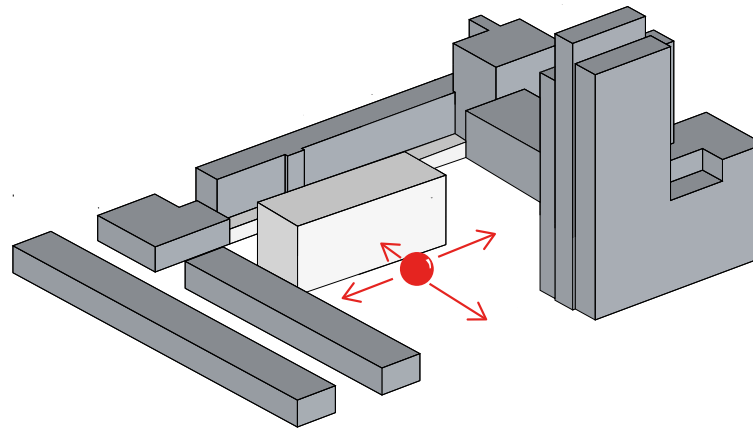

Masterplan

Designrules

A square is defined by its surroundings, it determines its identity.

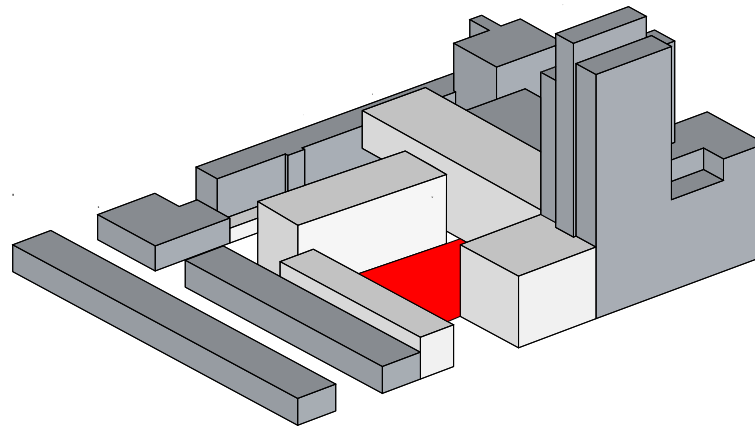

Masterplan

Designrules

For further development.
the building near to the Coolsingel is choosen.

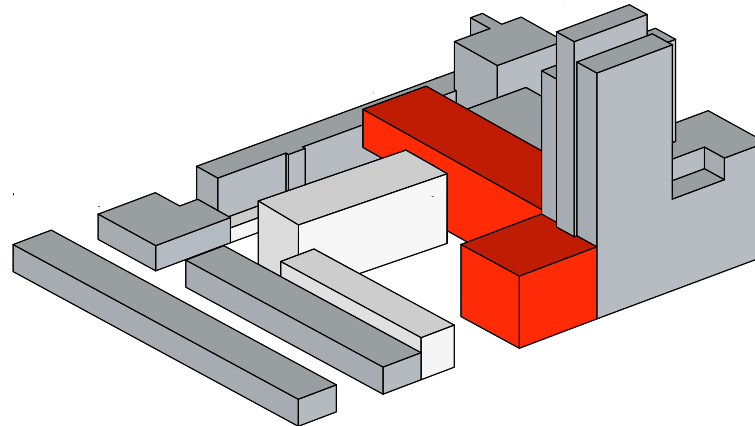

Design

Design

First Skectes

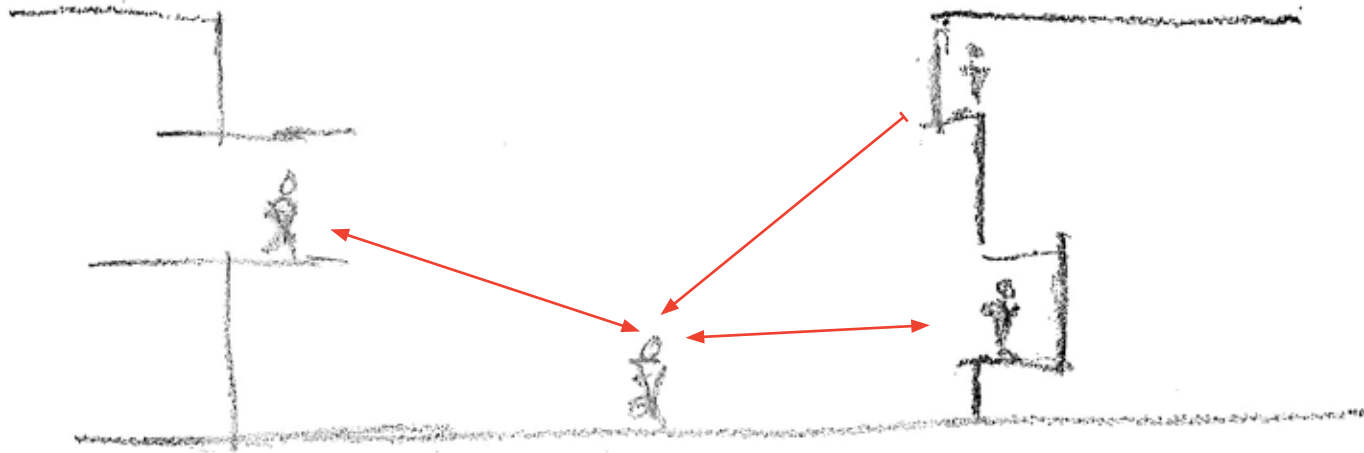

Concept

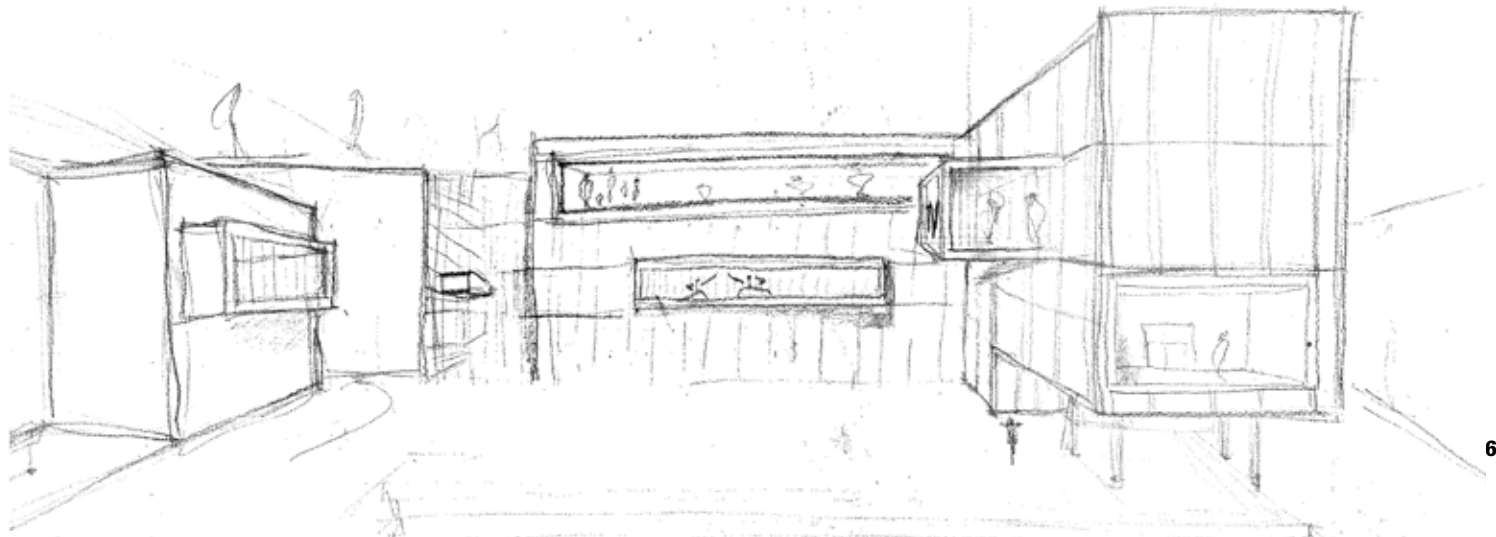

Design

First Sketches

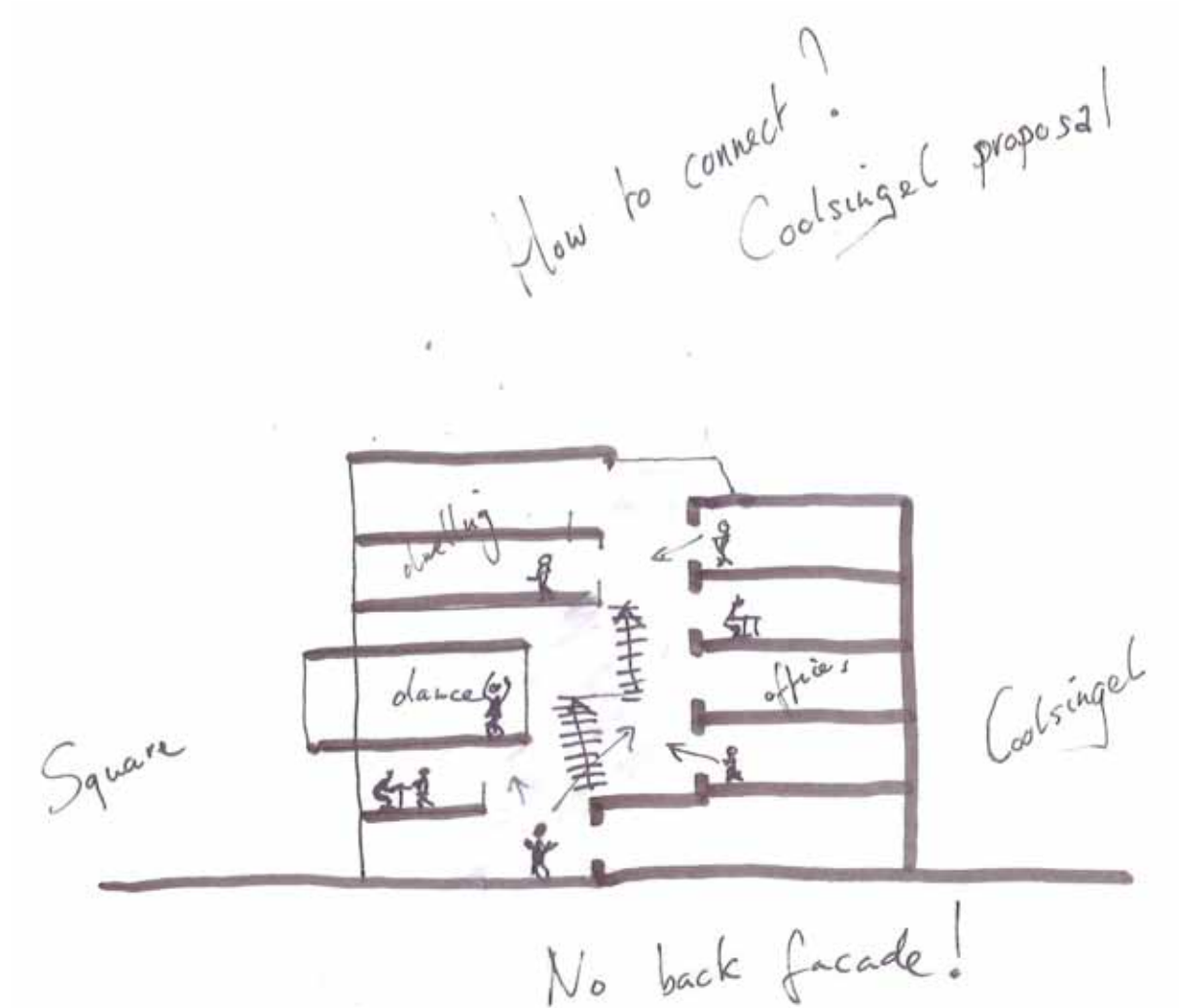









Kampung Kebon Kacang, Jakarta, Indonesia

BOOSAPP

Go JAWA

Design

Inspiration

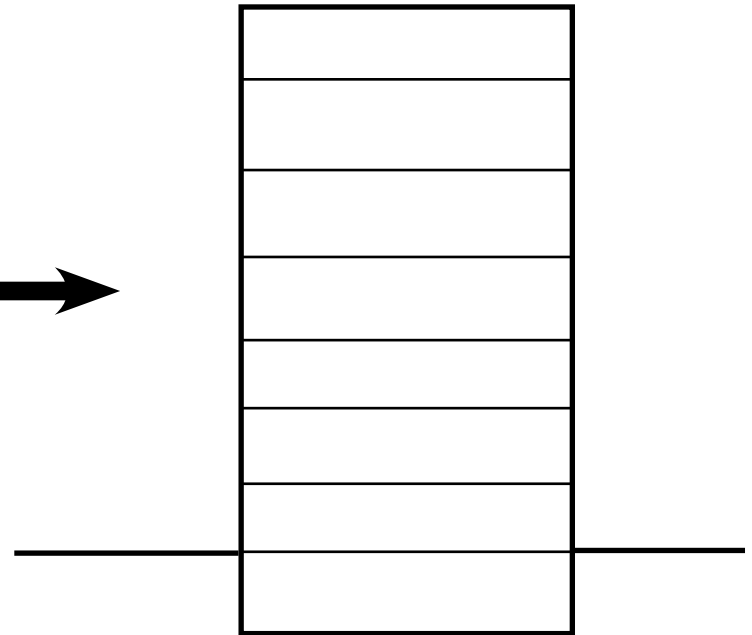

Design

Theory

'In the older neighborhoods the streets have degenerated into free-ways, leisure activities are commercialized and denatured by tourism. Social relations become impossible there.'

-'Constant, Another city for another life'-

Design

Theory

'In the older neighborhoods the streets have degenerated into free-ways, leisure activities are commercialized and denatured by tourism. Social relations become impossible there.'

-'Constant, Another city for another life'-

'...The public space is a space for human and social interaction, a rich spatial instrument to see and to be seen, to participate and to withdraw, and to be the actor or the spectator in the theatre of social interaction at one's will. The public space is also a museum and a library of patterns of life and culture, and an instruction manual for appropriate societal behaviour.'

-'Juhani Pallasmaa, Inhabiting space and time-the loss an recovery of Public Space'-

Design

Theory

'In the older neighborhoods the streets have degenerated into free-ways, leisure activities are commercialized and denatured by tourism. Social relations become impossible there.'

-'Constant, Another city for another life'-

'...The public space is a space for human and social interaction, a rich spatial instrument to see and to be seen, to participate and to withdraw, and to be the actor or the spectator in the theatre of social interaction at one's will. The public space is also a museum and a library of patterns of life and culture, and an instruction manual for appropriate societal behaviour.'

-'Juhani Pallasmaa, Inhabiting space and time-the loss and recovery of Public Space'-

Identity conceived as this form of sharing the past is a losing proposition: not only is there - in a stable model of continuous population expansion - proportionally less and less to share, but history also has an invidious half-life as it is more and more abused, it becomes less significant - to the point where its diminishing handouts become insulting.

-'Rem Koolhaas, Generic City'-

Design

Program

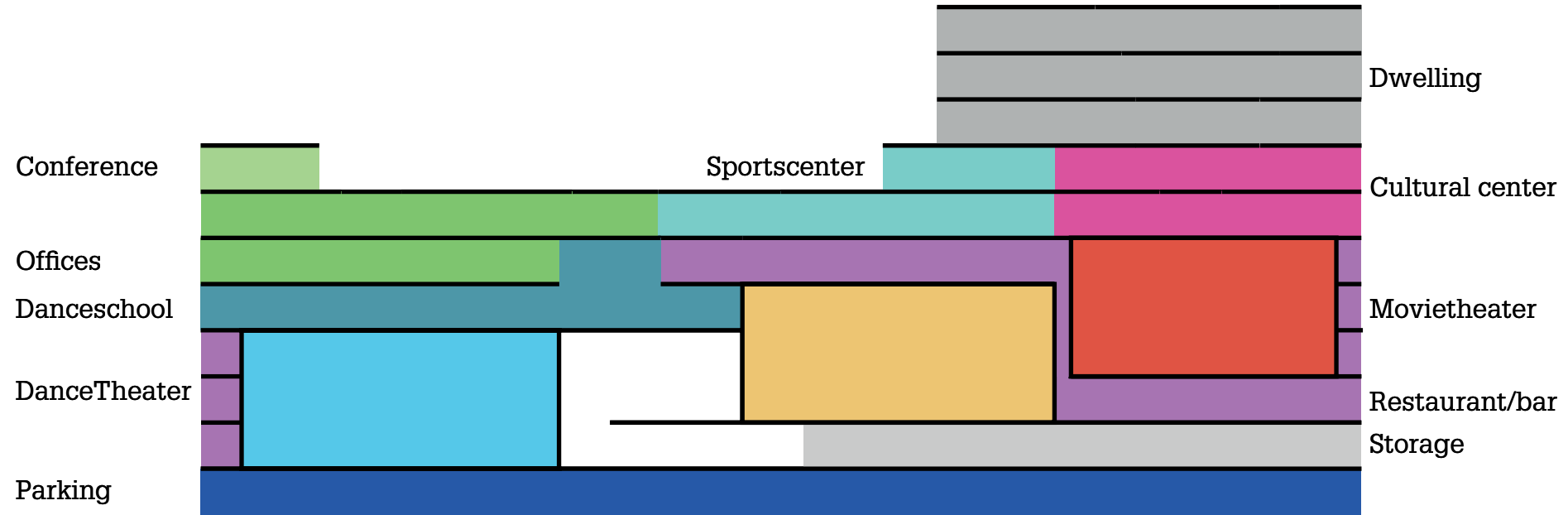

Design

Program

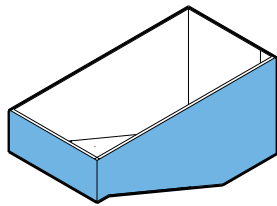
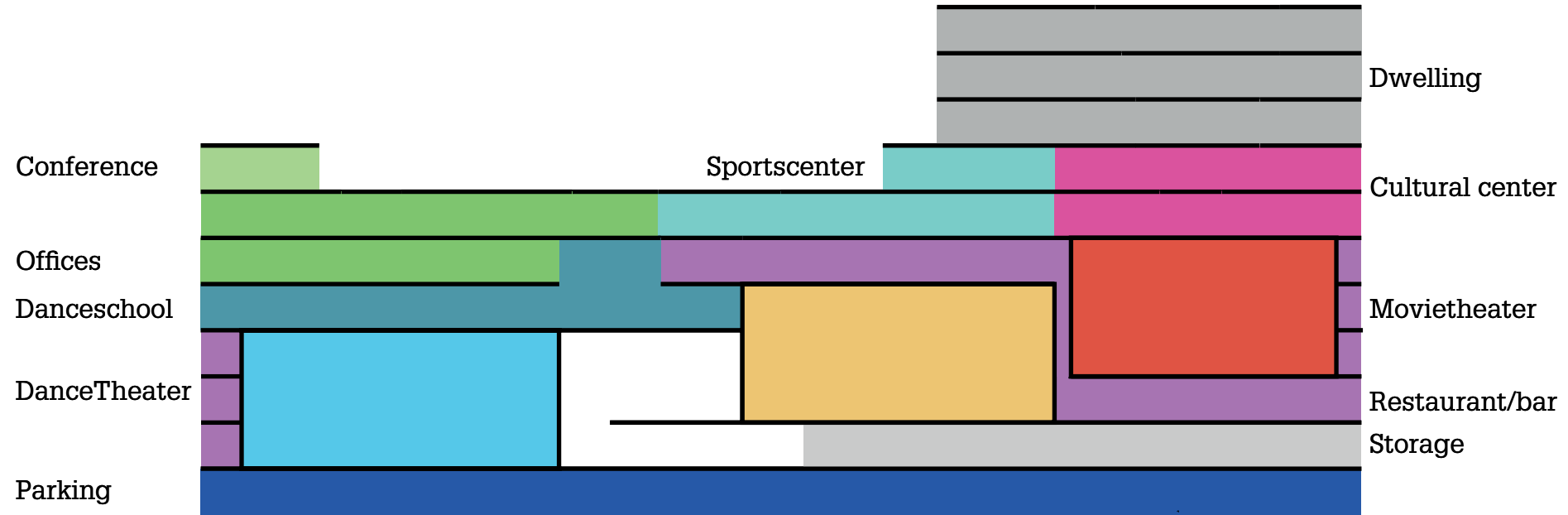

Dancetheater 250 p

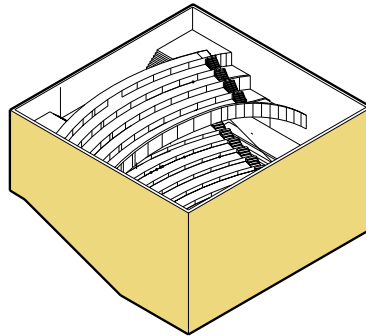

Performancetheater 650 p

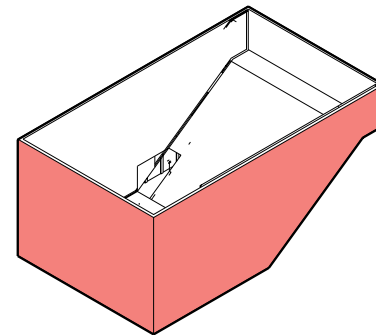

Movietheater 350p

Design

Program

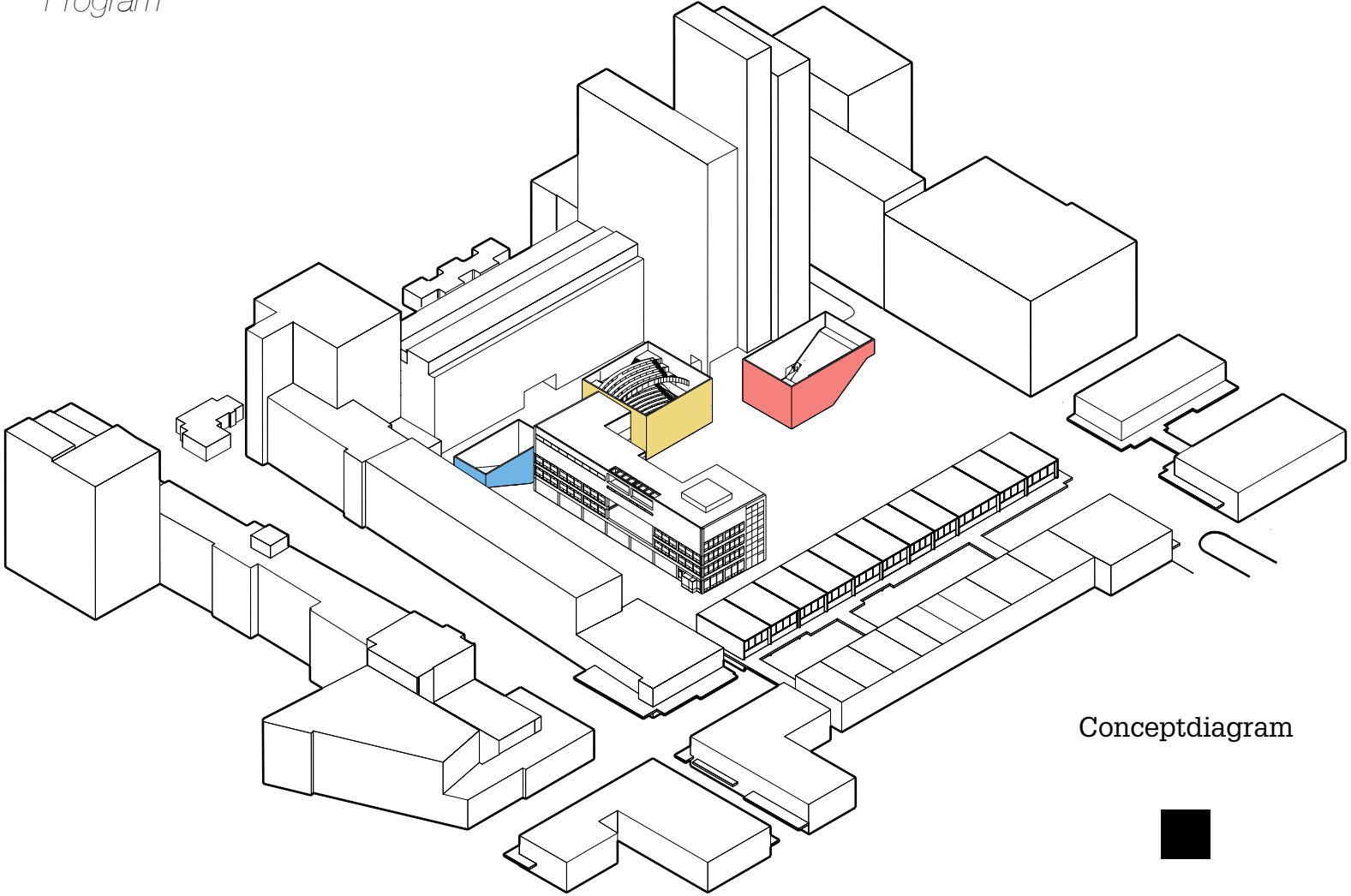

Conceptdiagram



Design

Total Volume

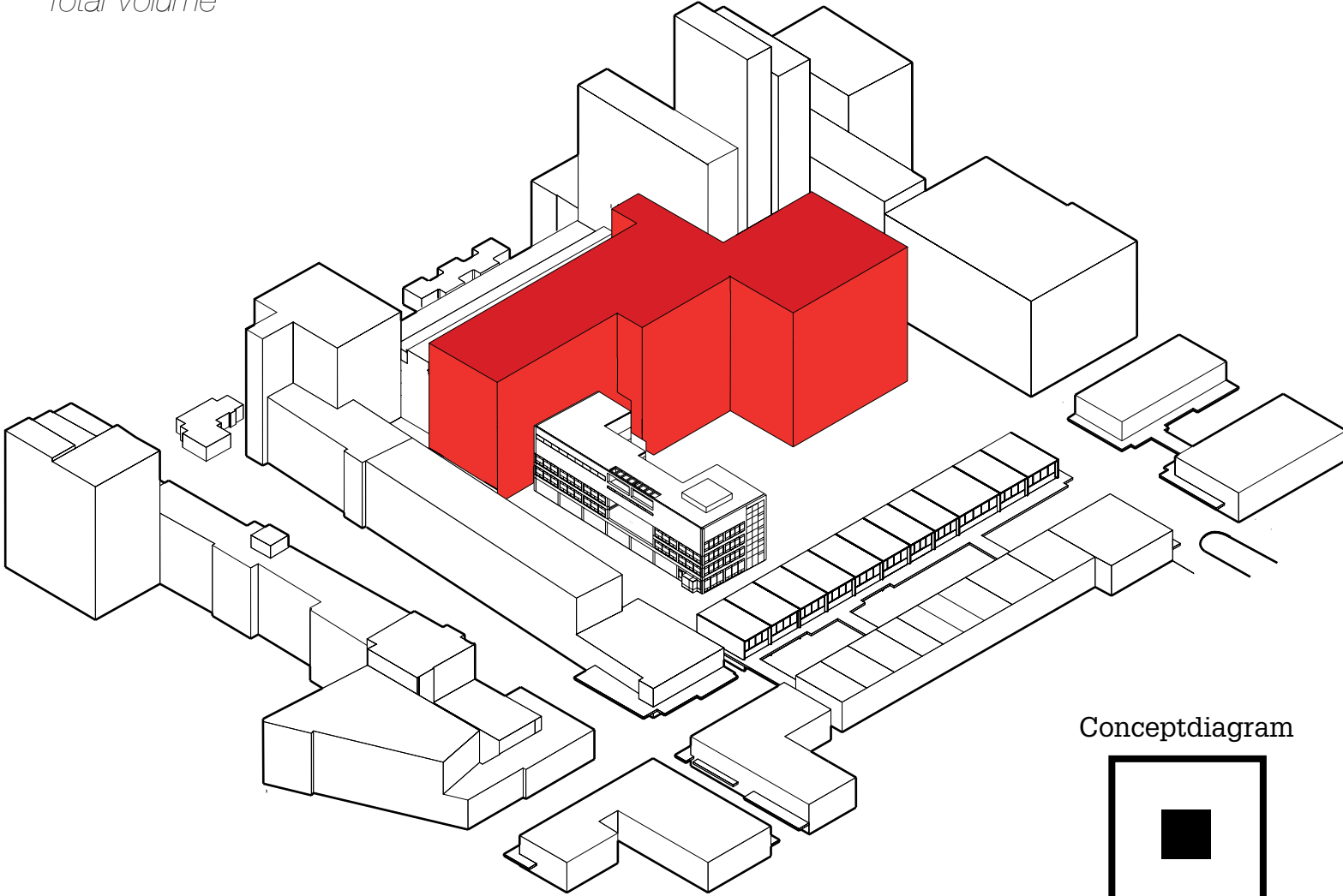

Conceptdiagram

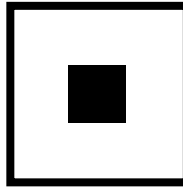

Design

Volume explosion

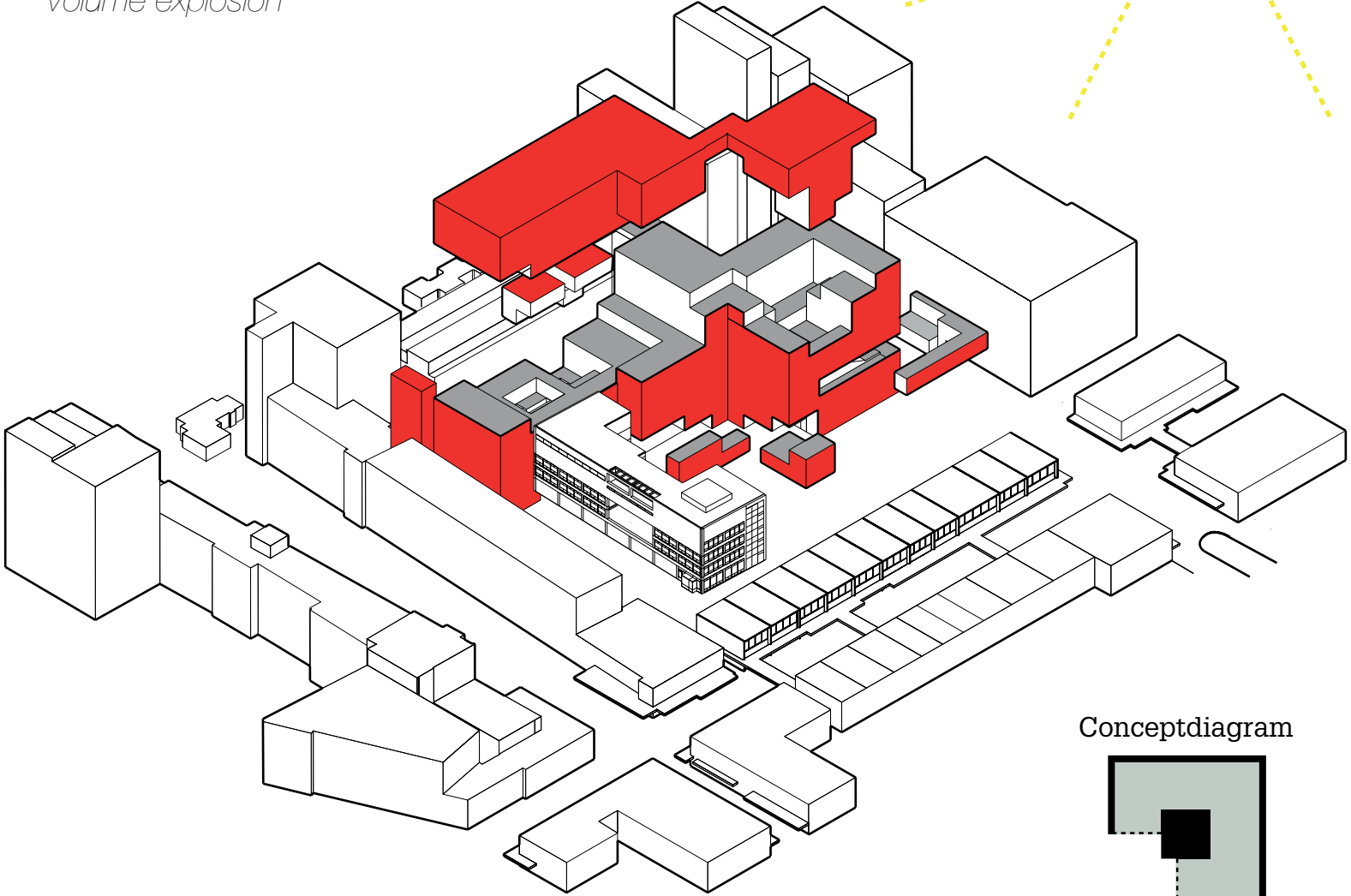
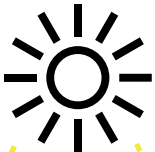

Conceptdiagram

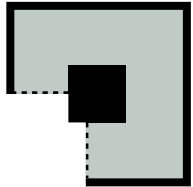

Design

Public Spaces

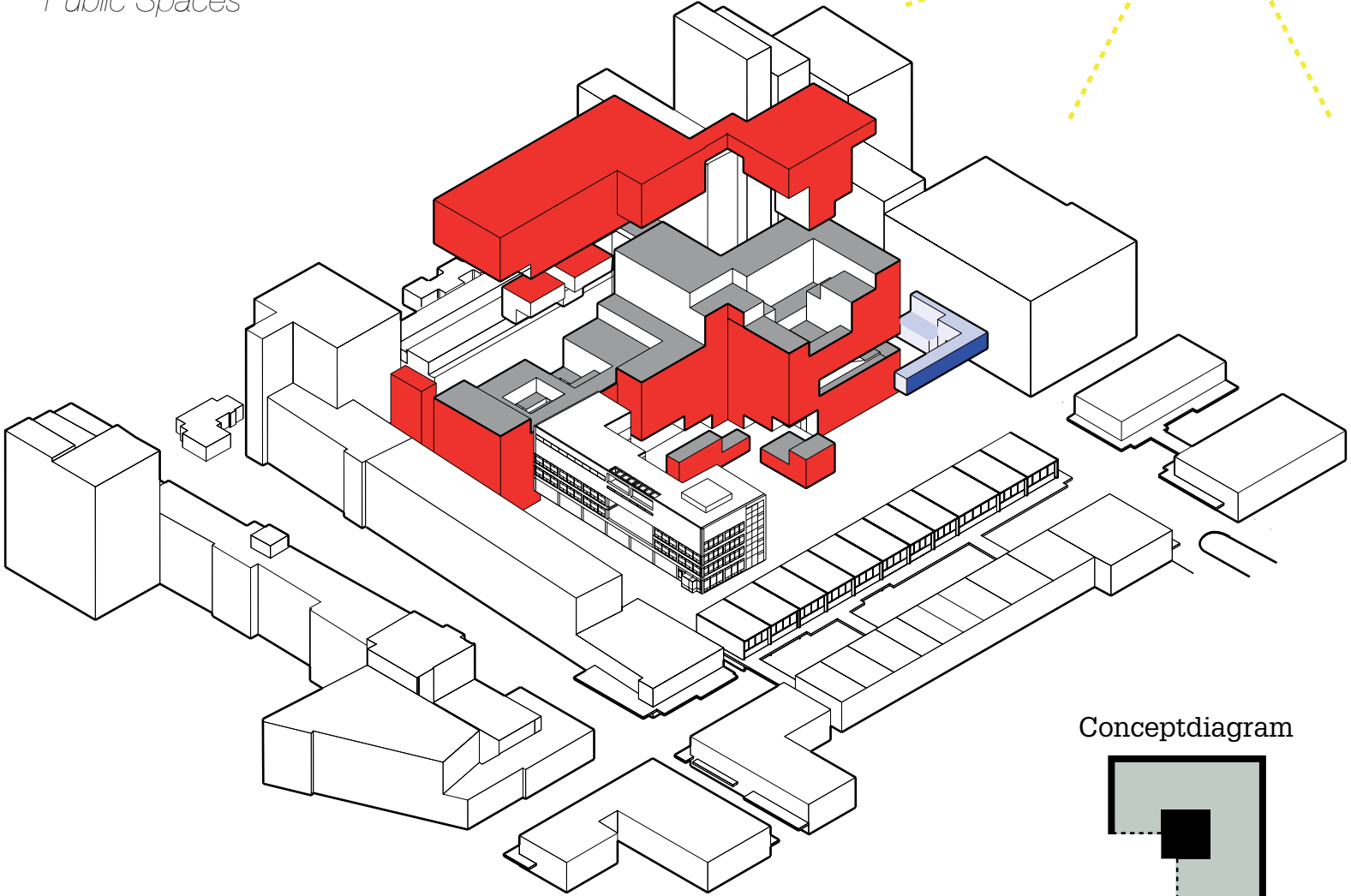
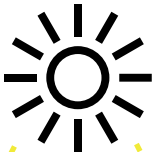

Conceptdiagram

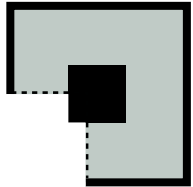

Design

Entrances

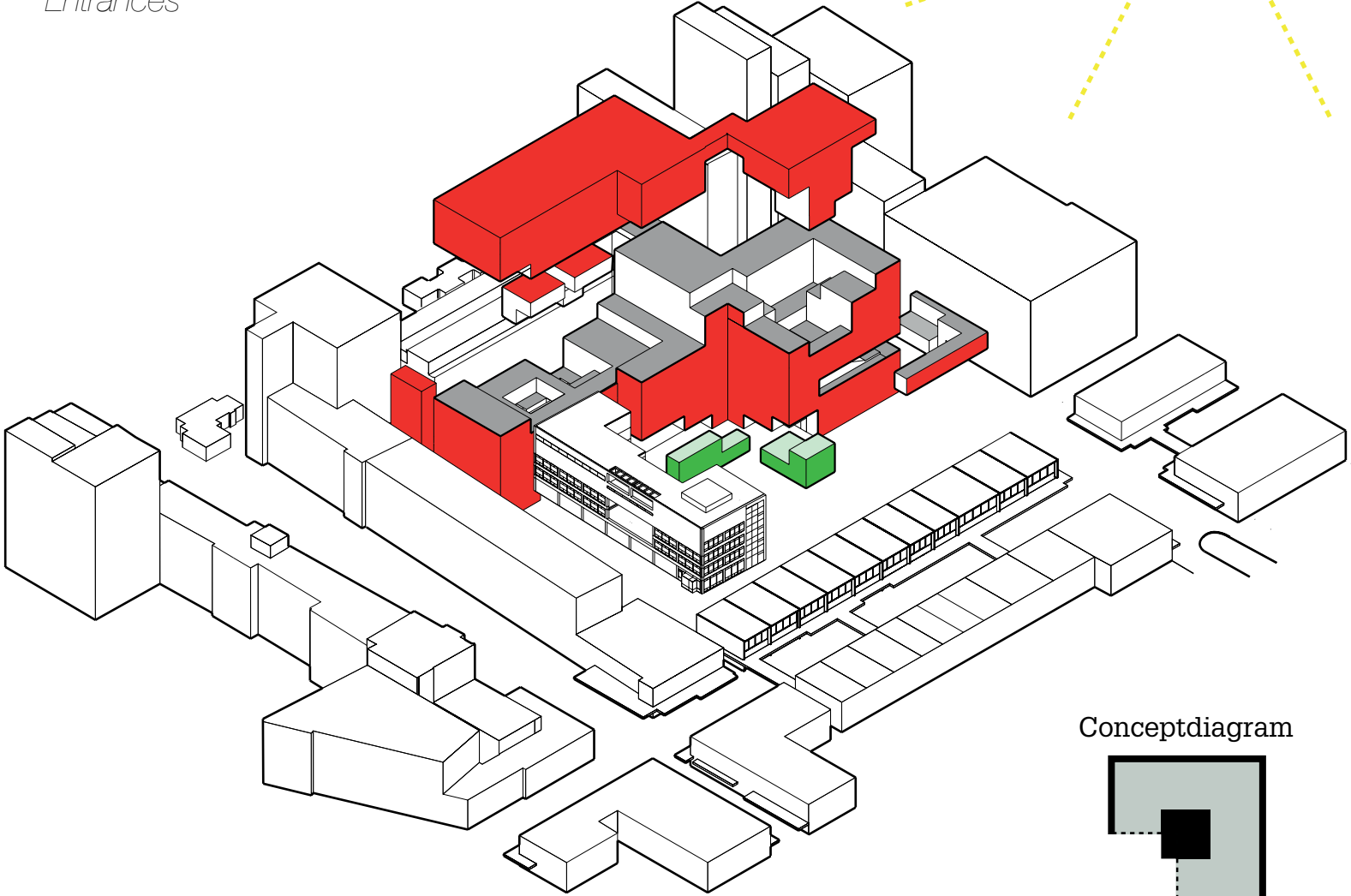
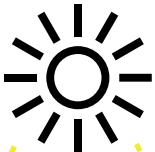

Conceptdiagram

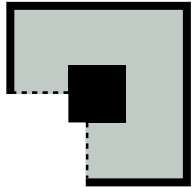

Design

Patio's and Roofgardens

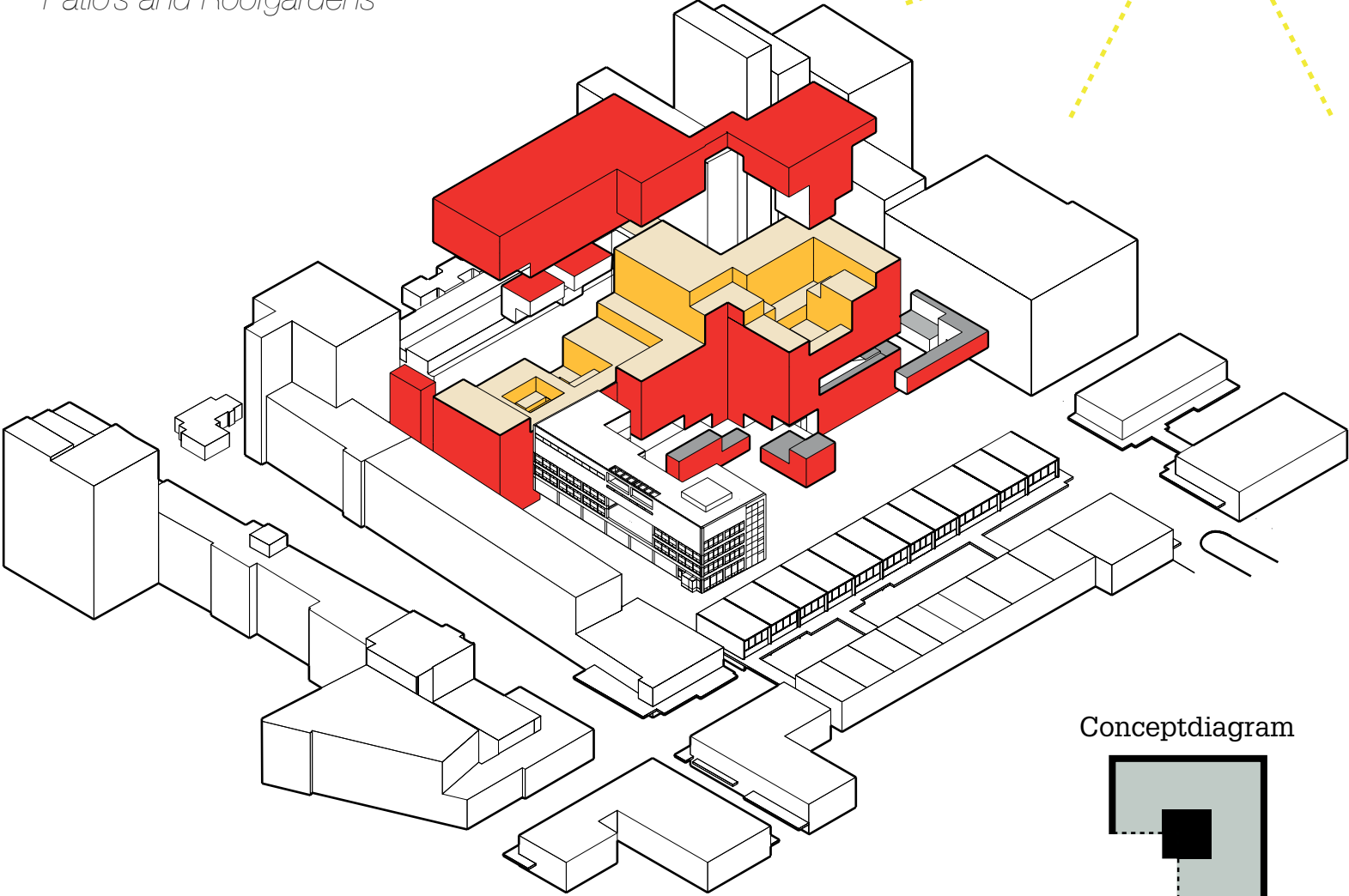
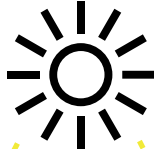

Conceptdiagram

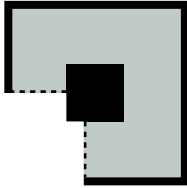

Design

Cutting route out

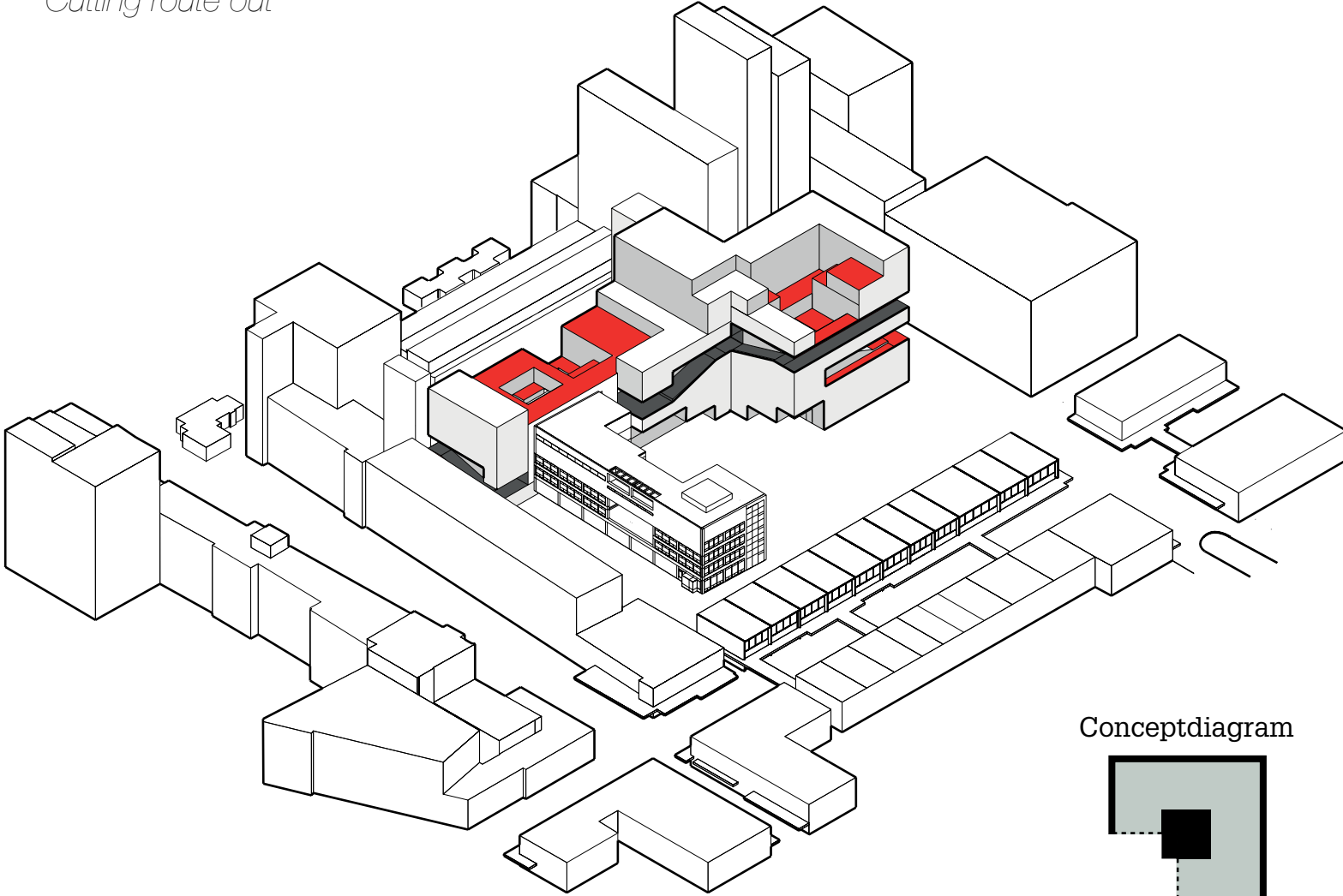

Conceptdiagram

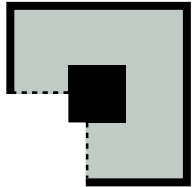

Design

Program generated

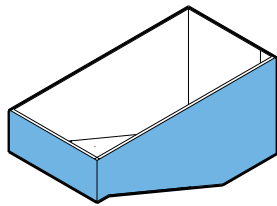
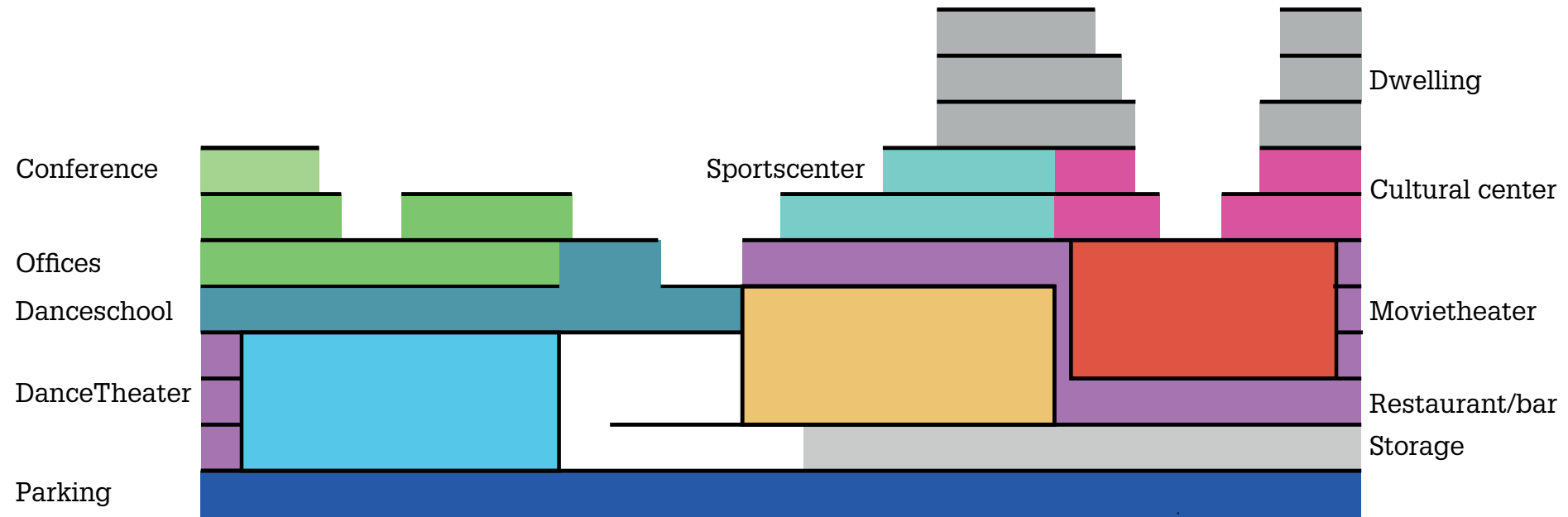

Dancetheater 250 p

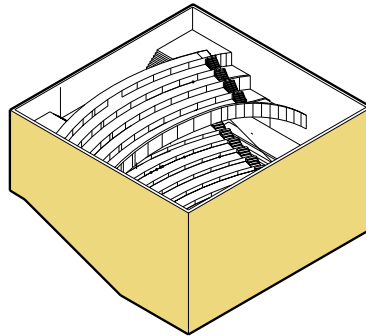

Performancetheater 650 p

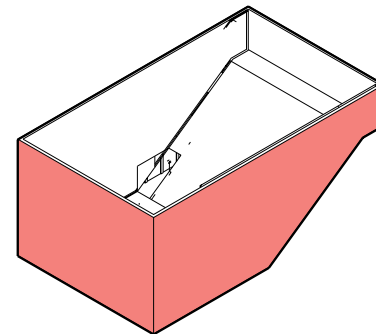

Movietheater 350p

Design

Situation

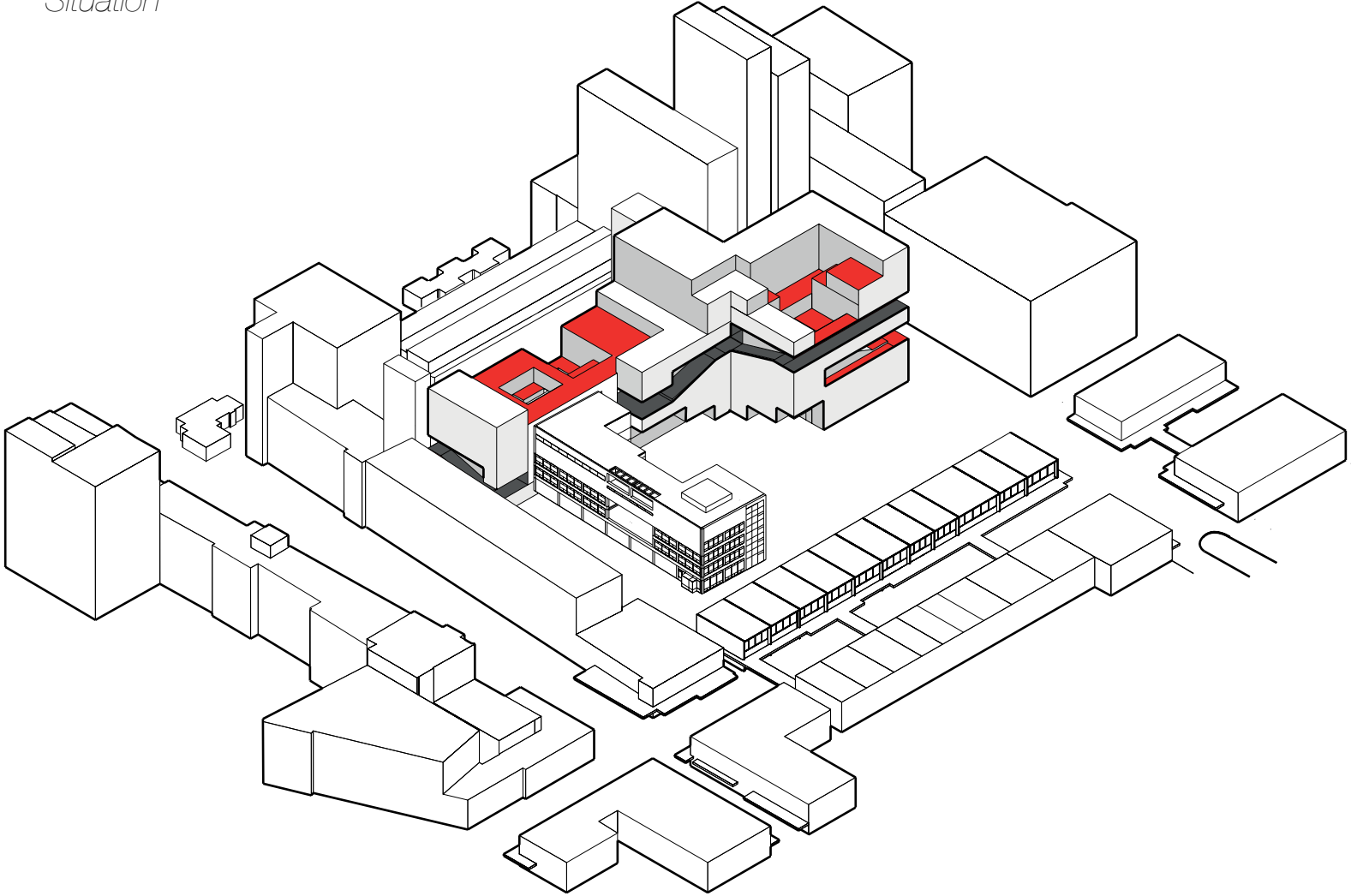

Design

Situation

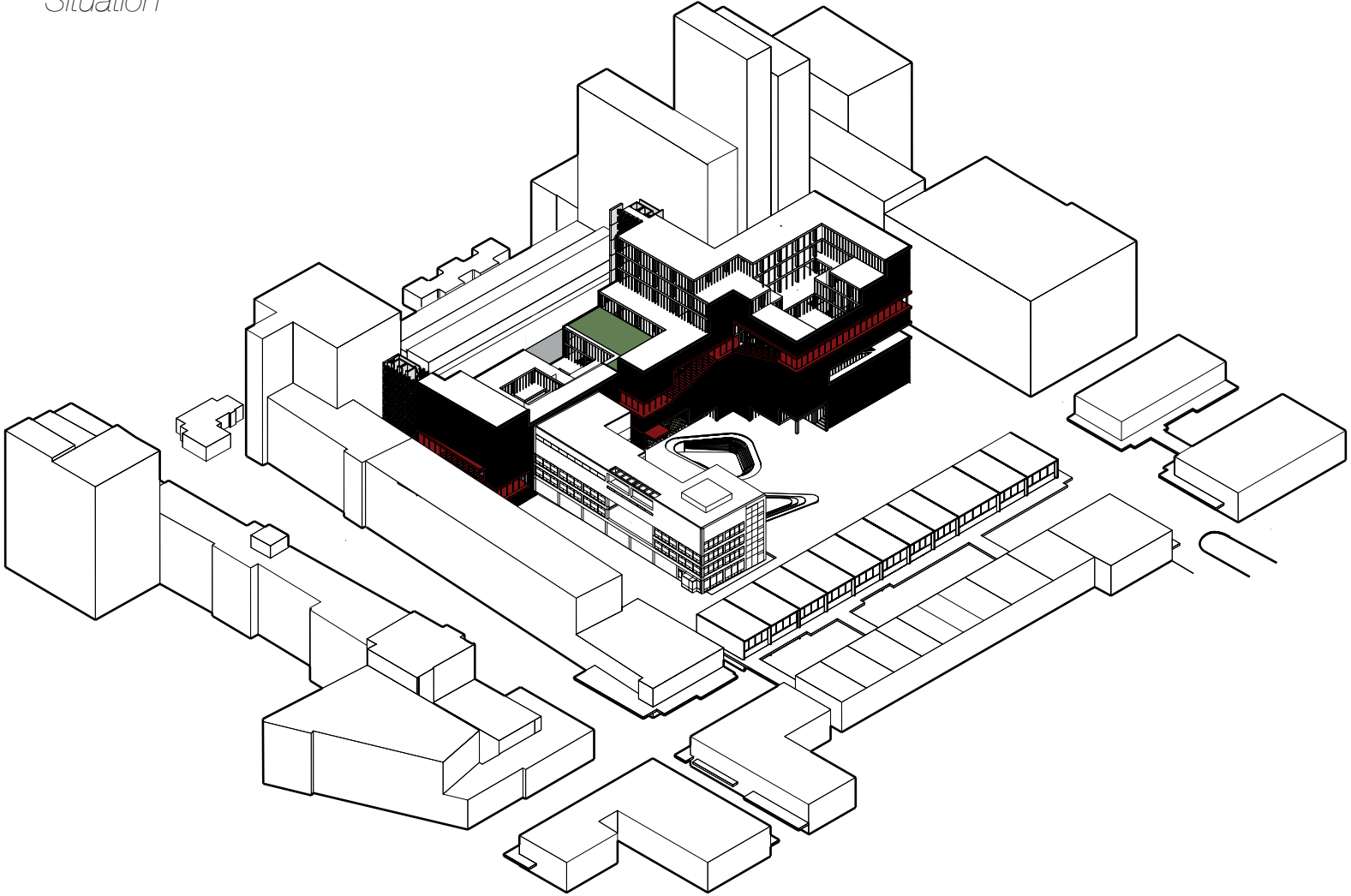

Design

Plans

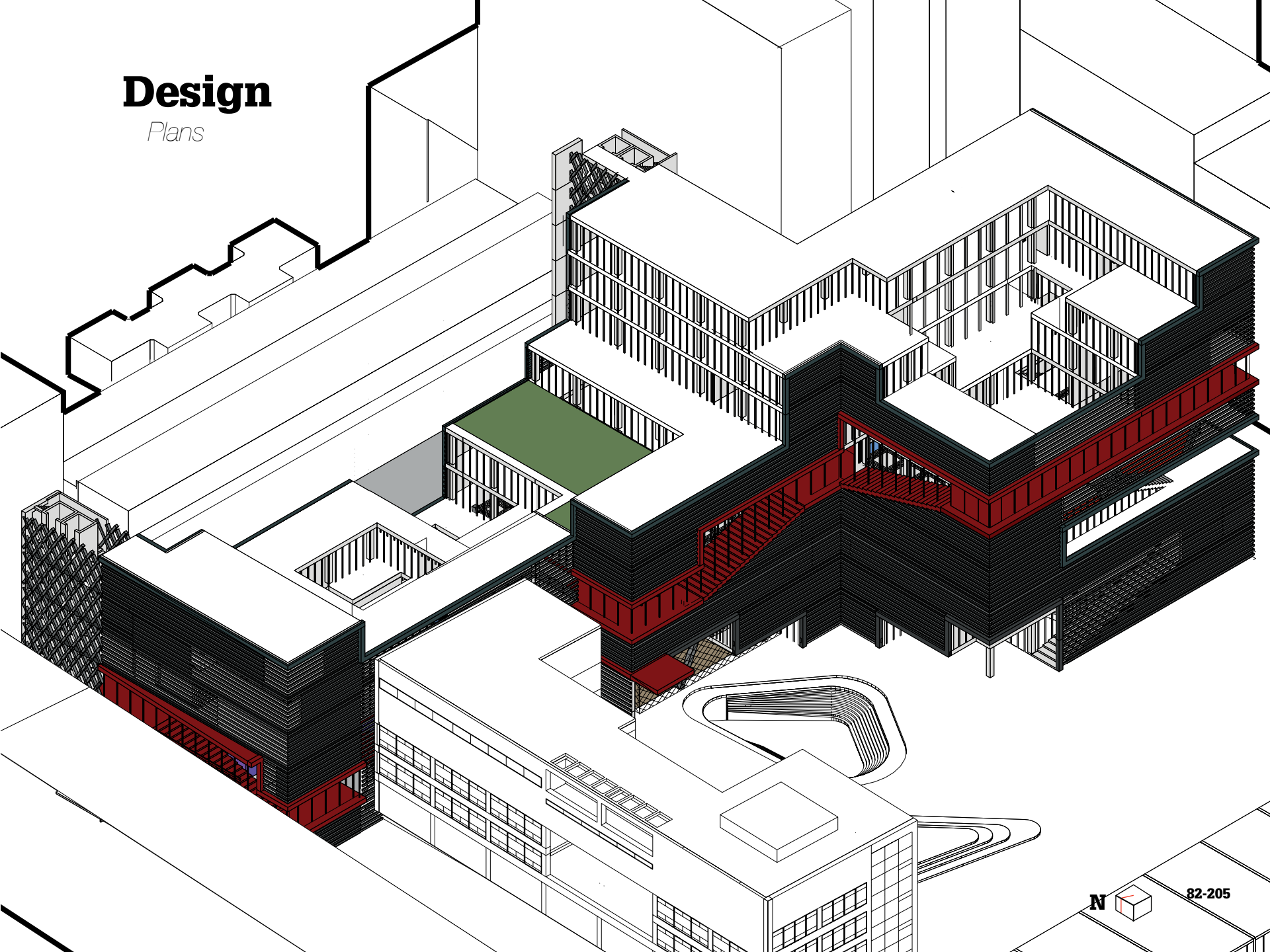

Design

Plans

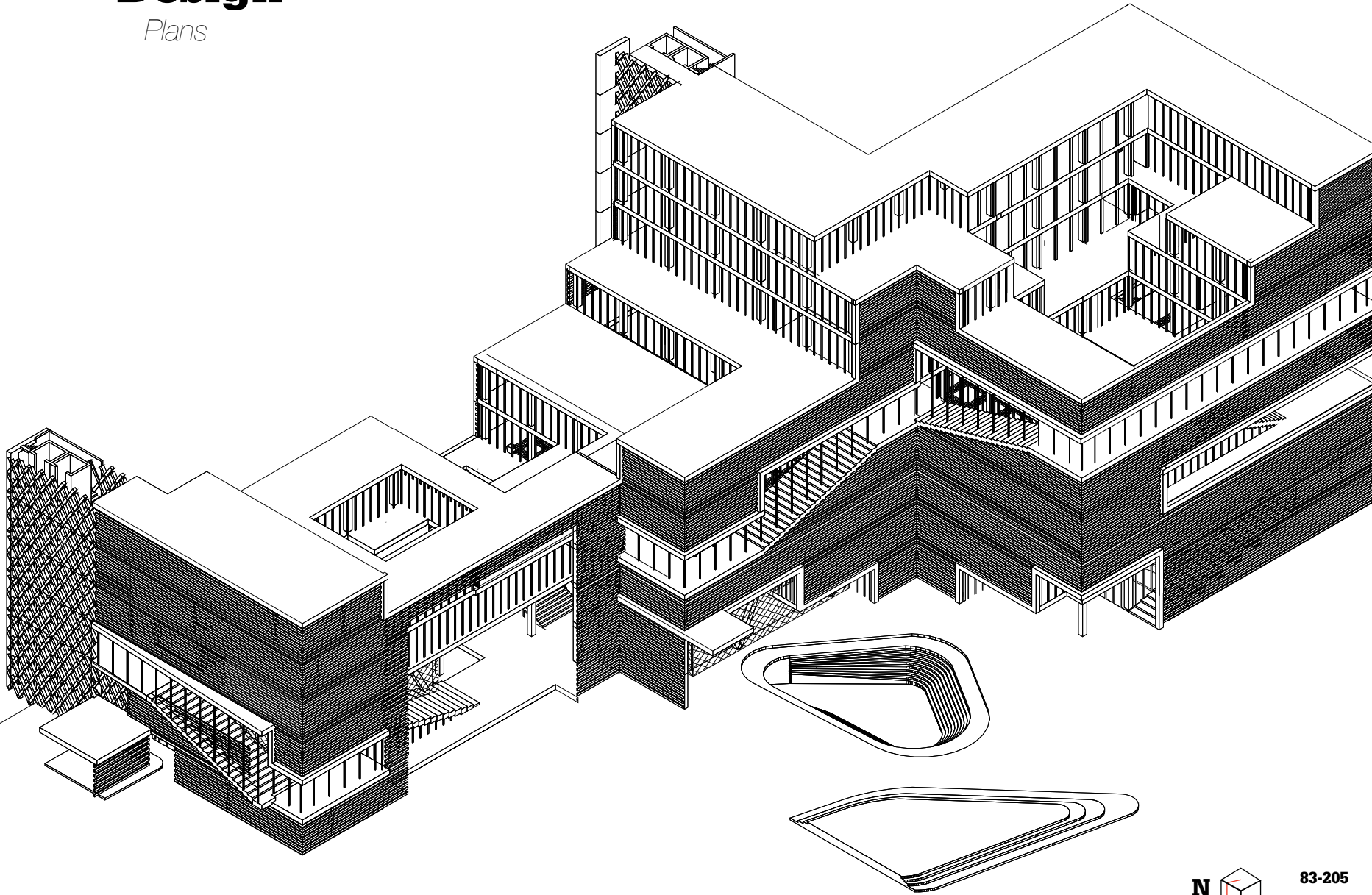

Design

Basement level

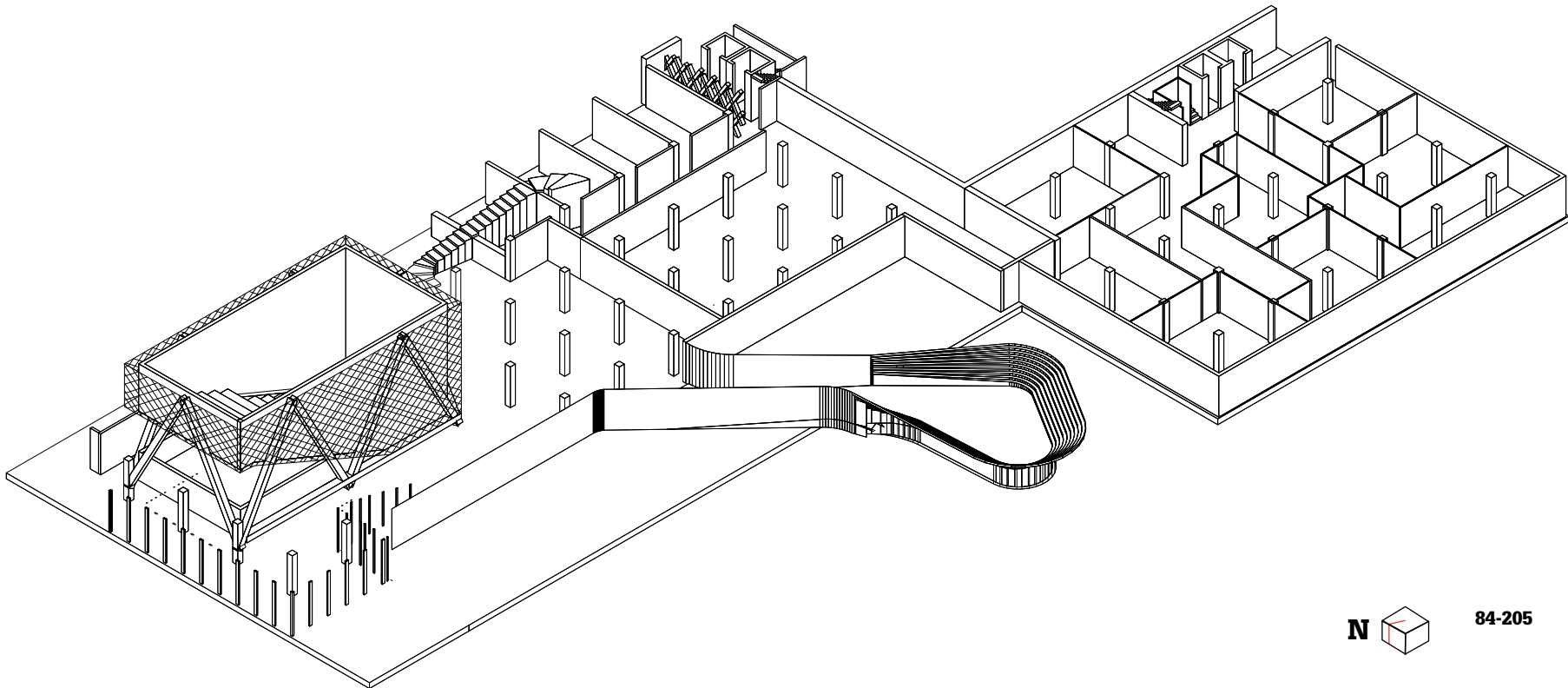

Design

Entry level

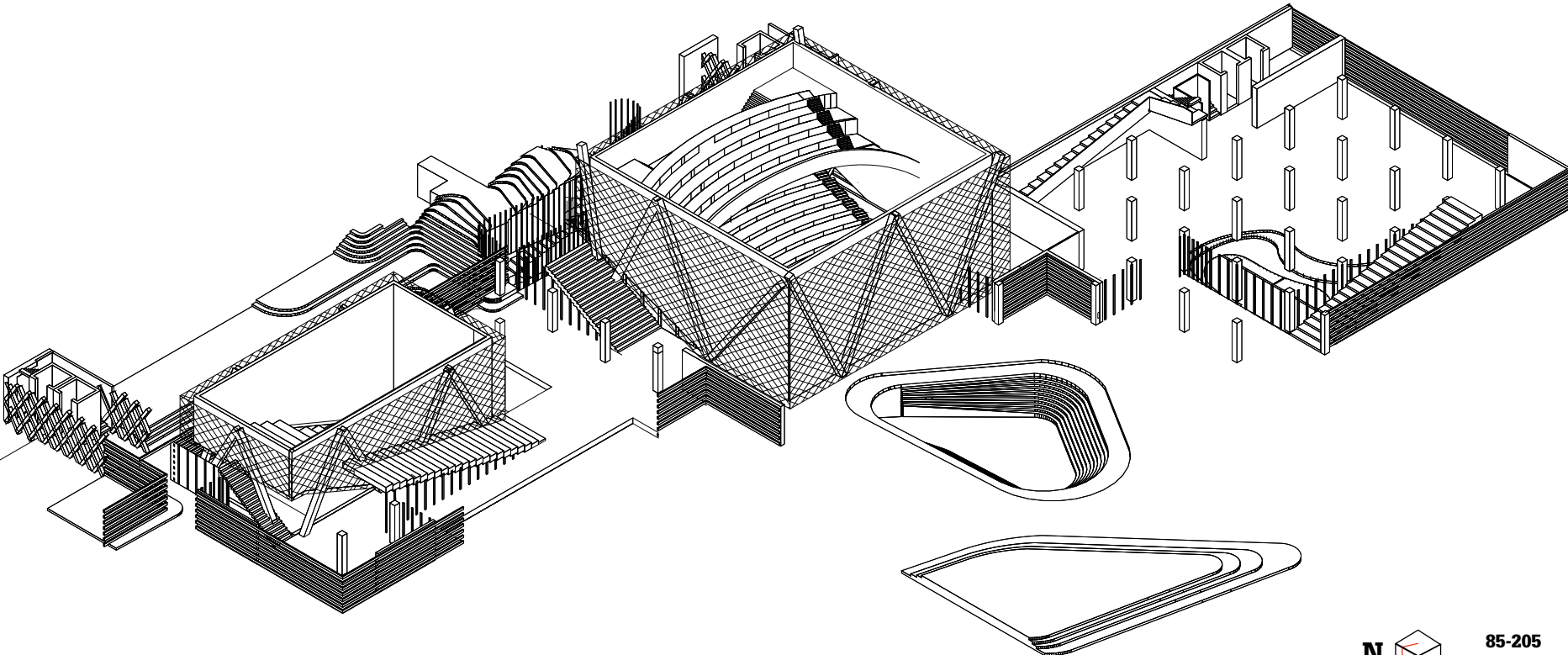

Design

Entry level

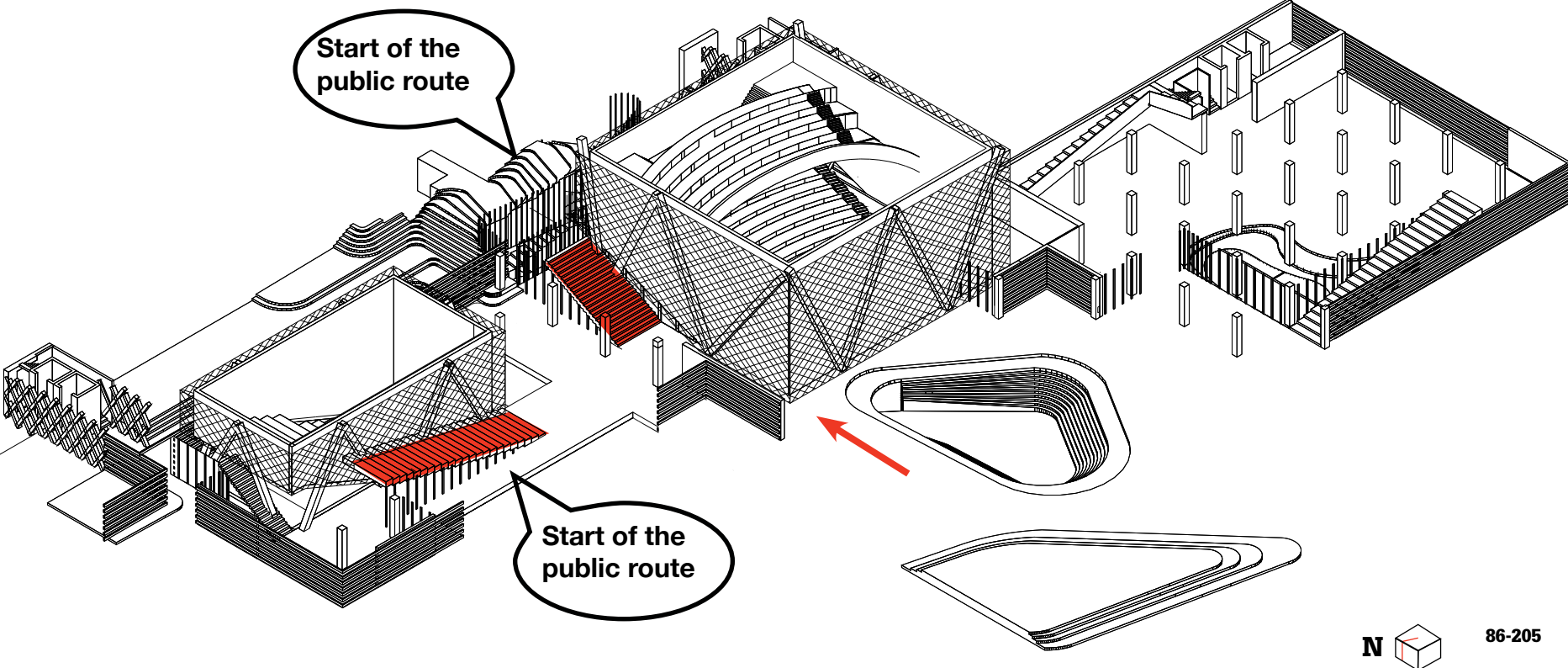

Design

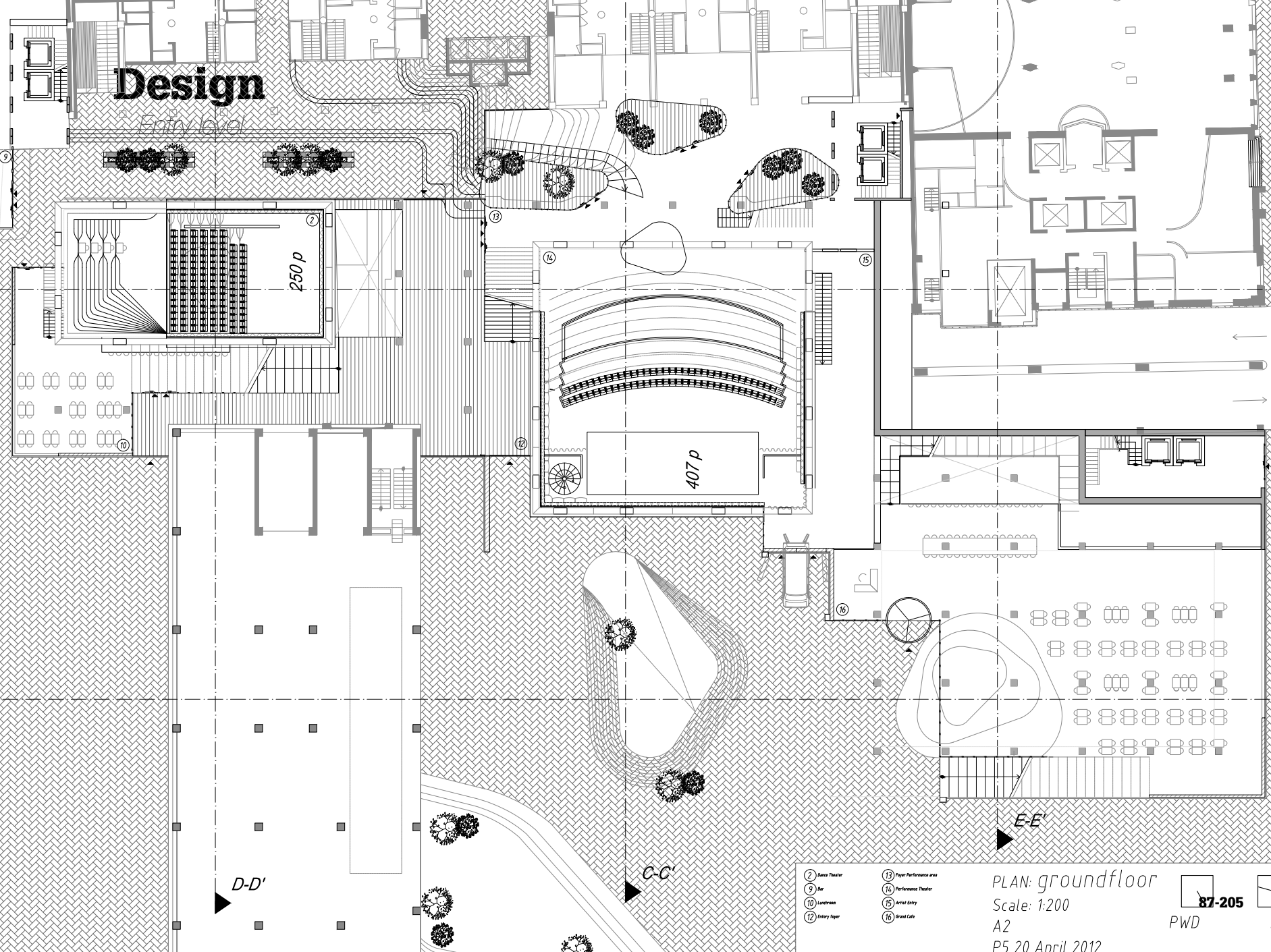

- ② Dance Theater
- ③ Foyer/Performance area
- ④ Bar
- ⑤ Performance Theater
- ⑥ Lobby area
- ⑦ Artist Entry
- ⑧ Restroom
- ⑨ Grand Cafe

PLAN: groundfloor
 Scale: 1:200
 A2
 P5 20 April 2012

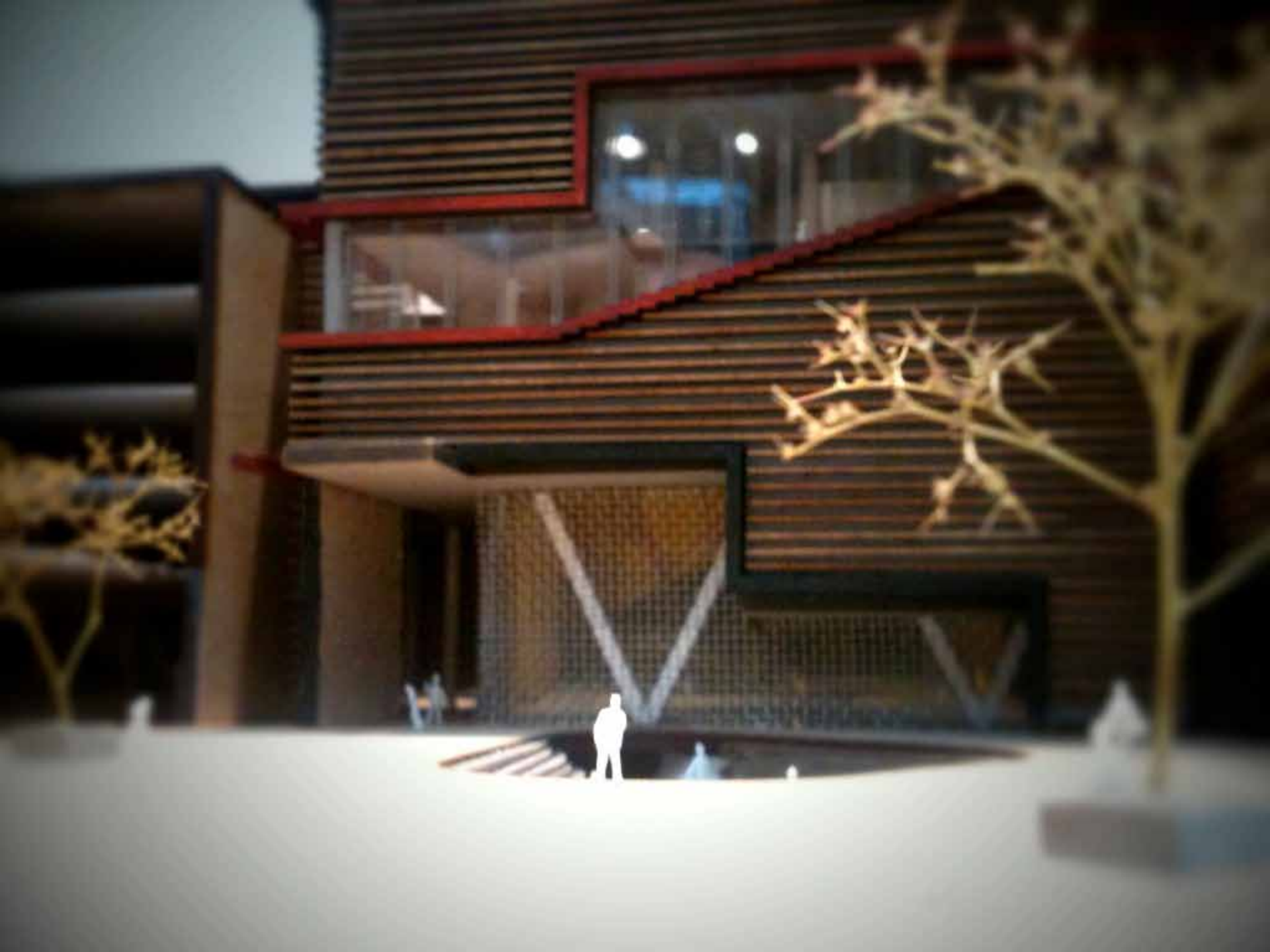





Design

Entry level

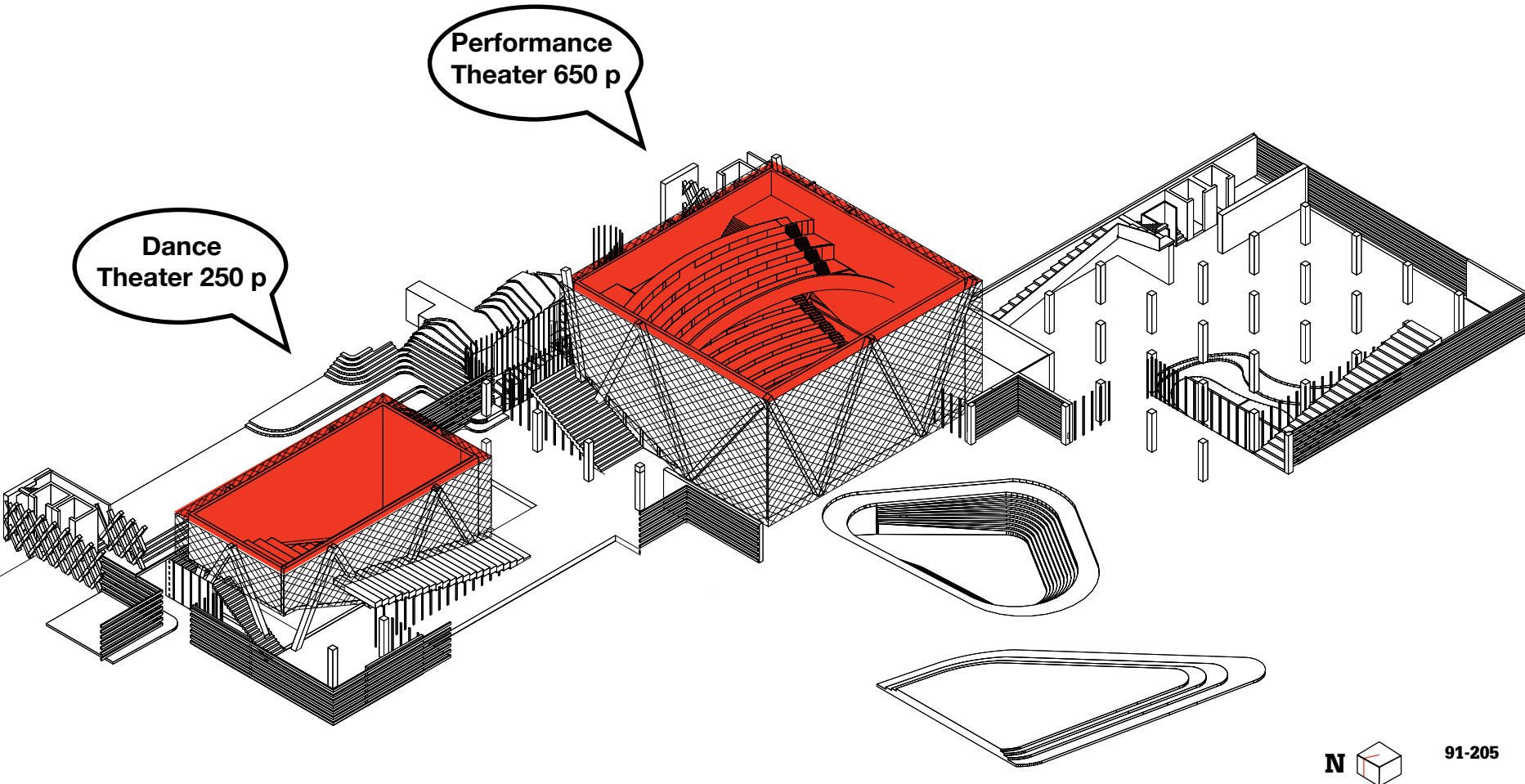

Dance Theater 250 p

Performance Theater 650 p





Design

Entry level

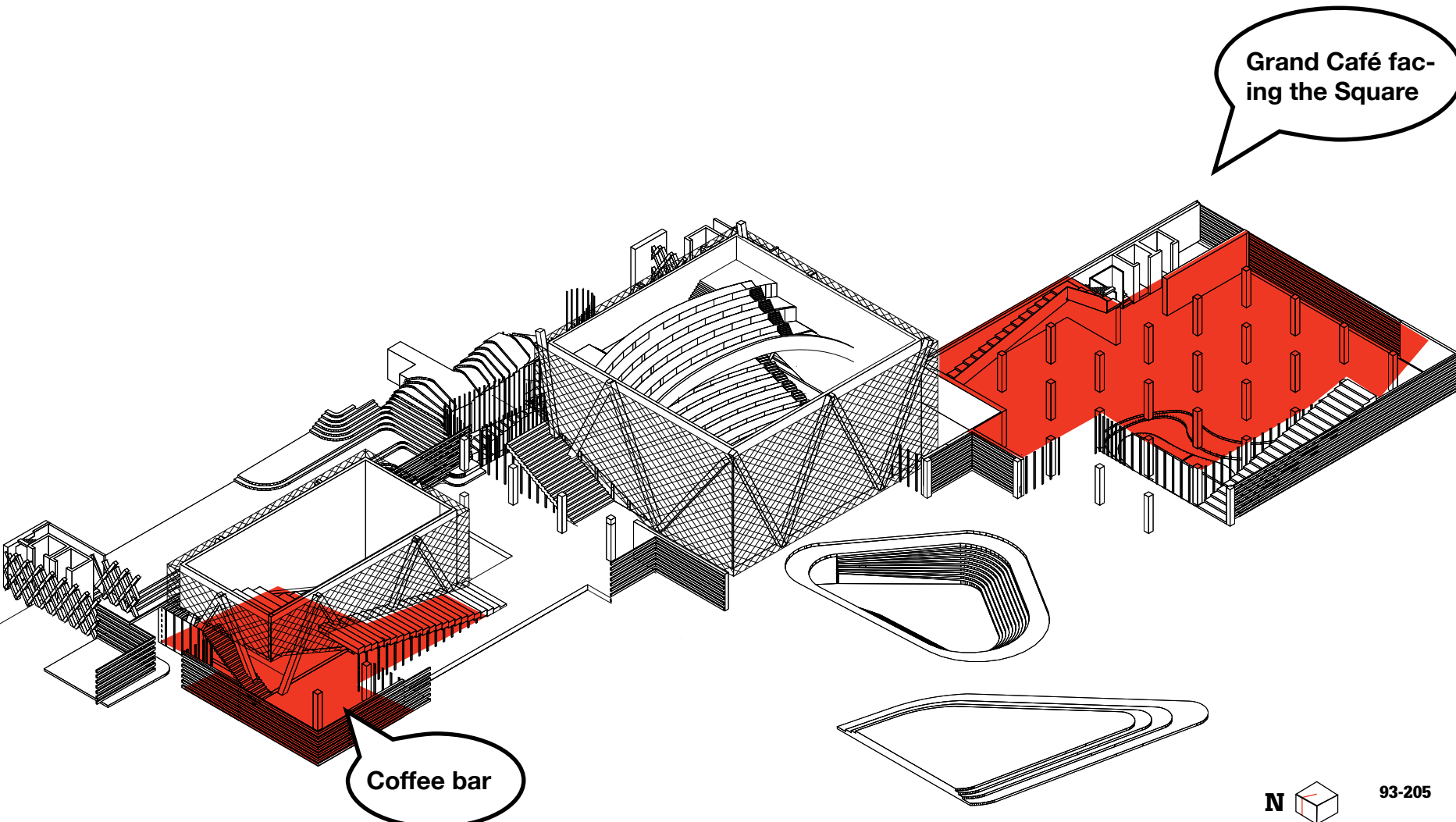

Grand Café facing the Square

Coffee bar





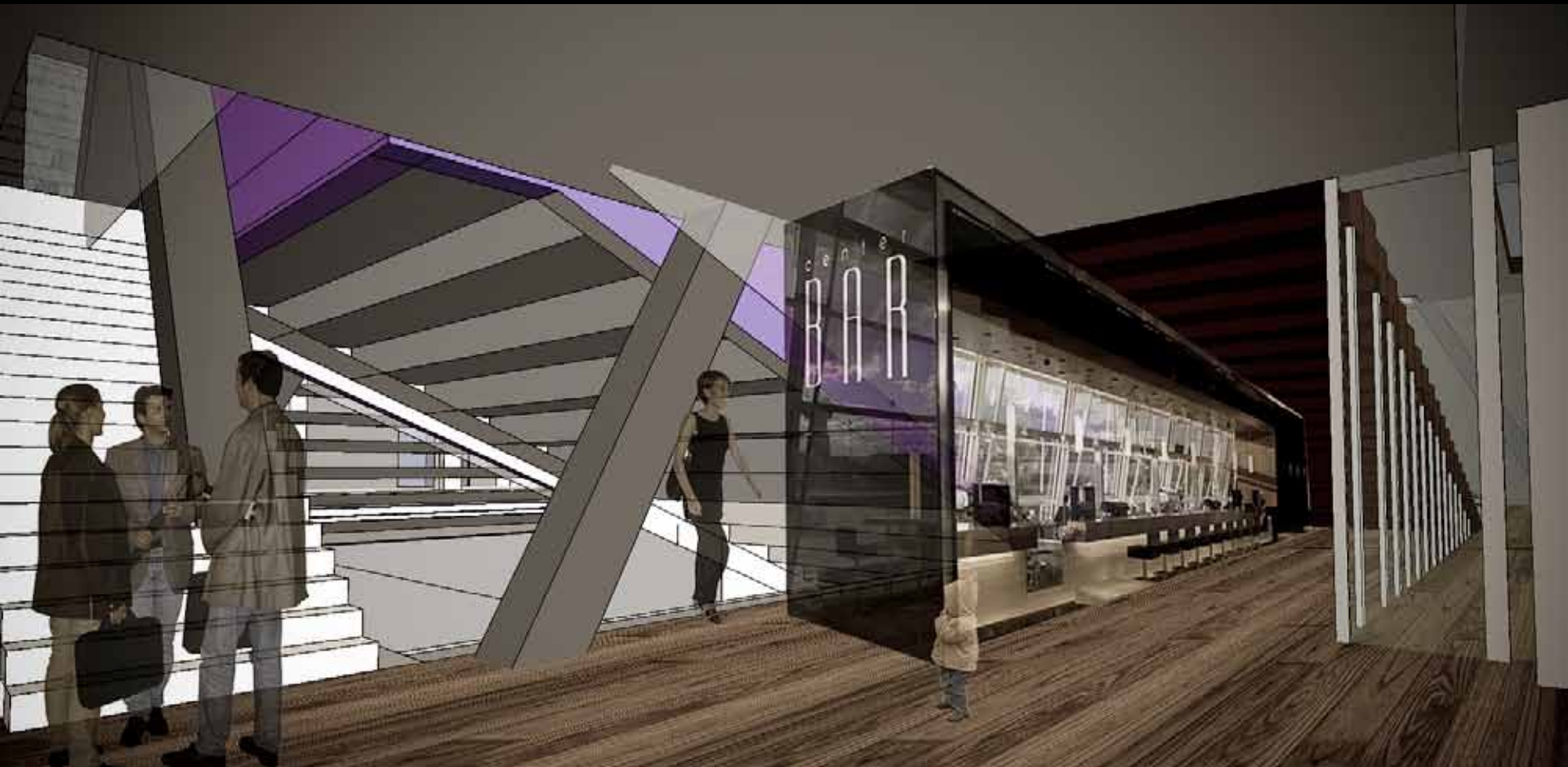

Design

1st Level

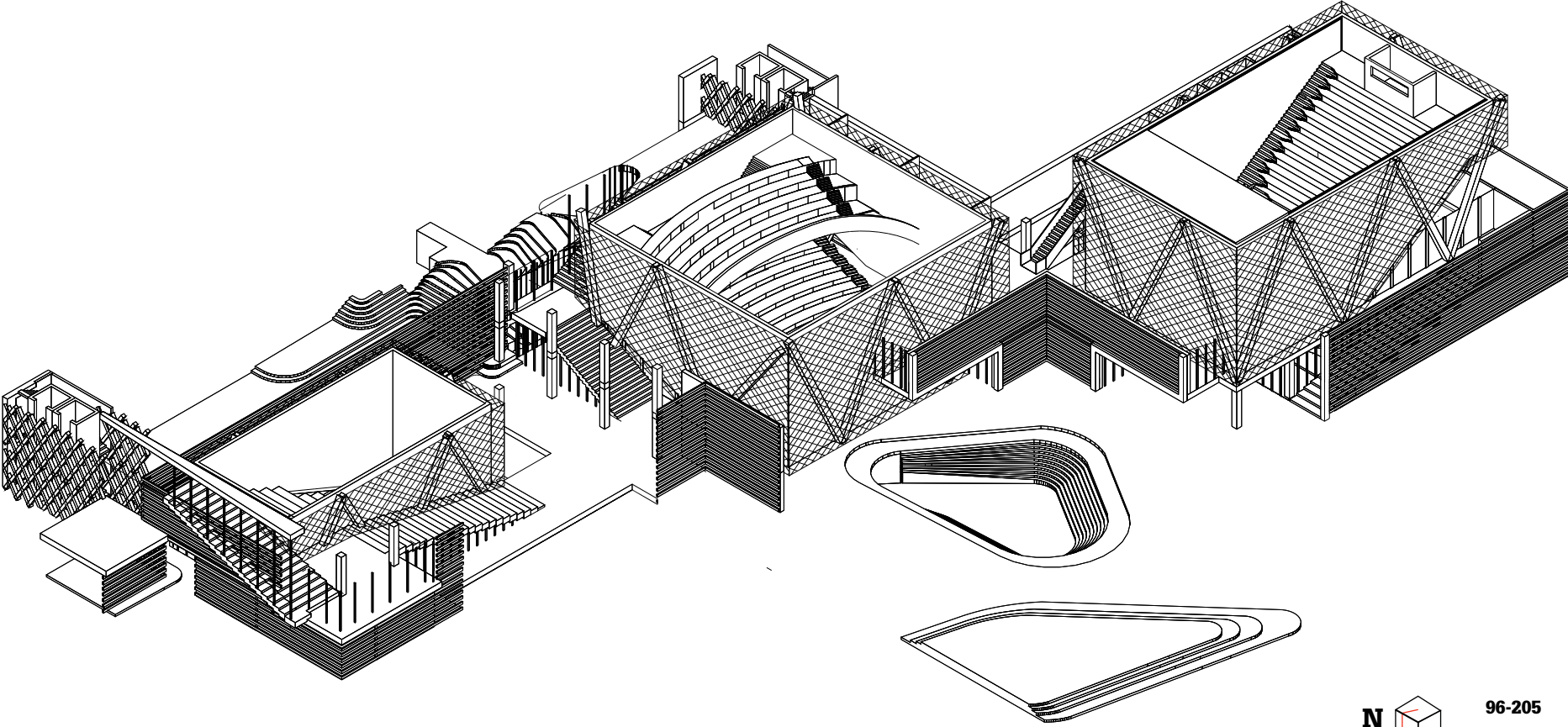

Design

1st Level

Movie Theater 350 p

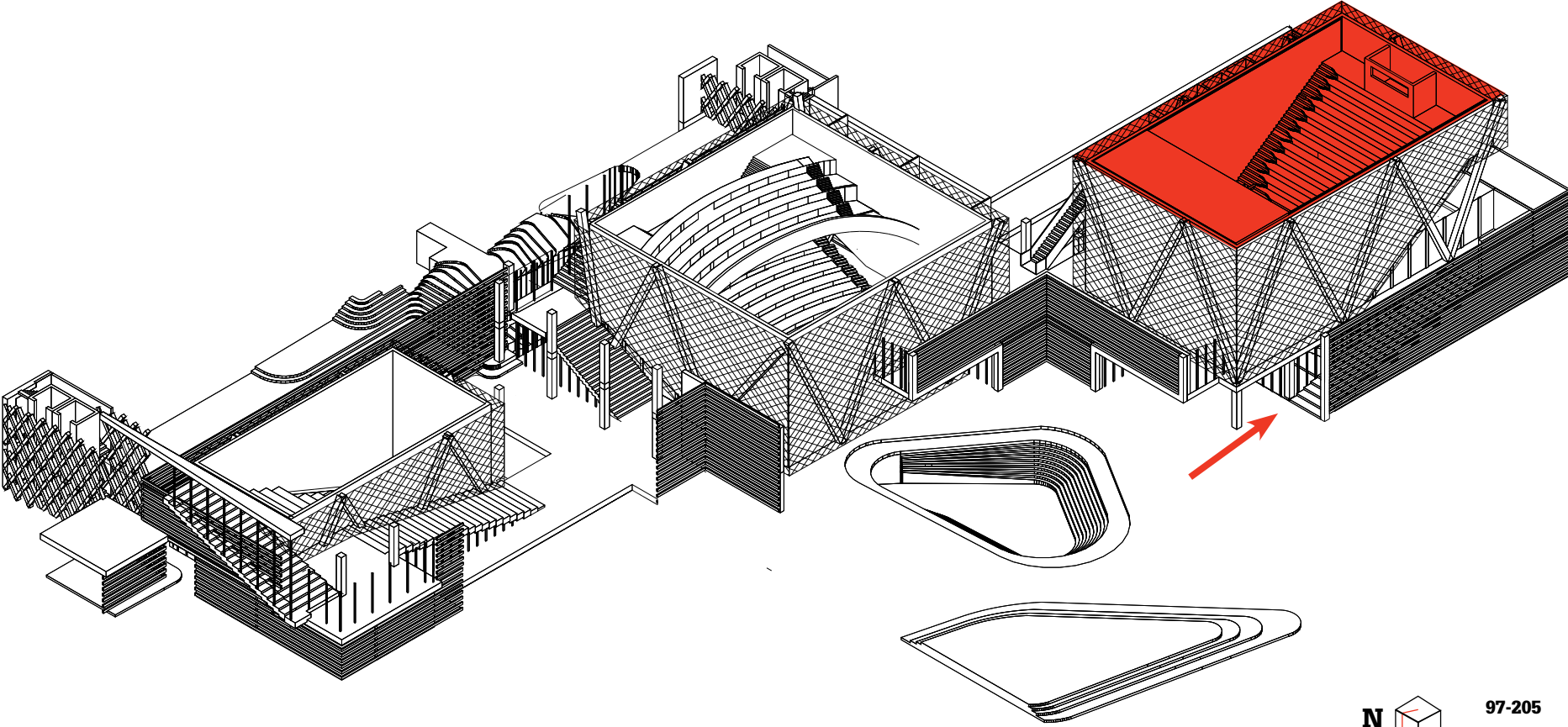

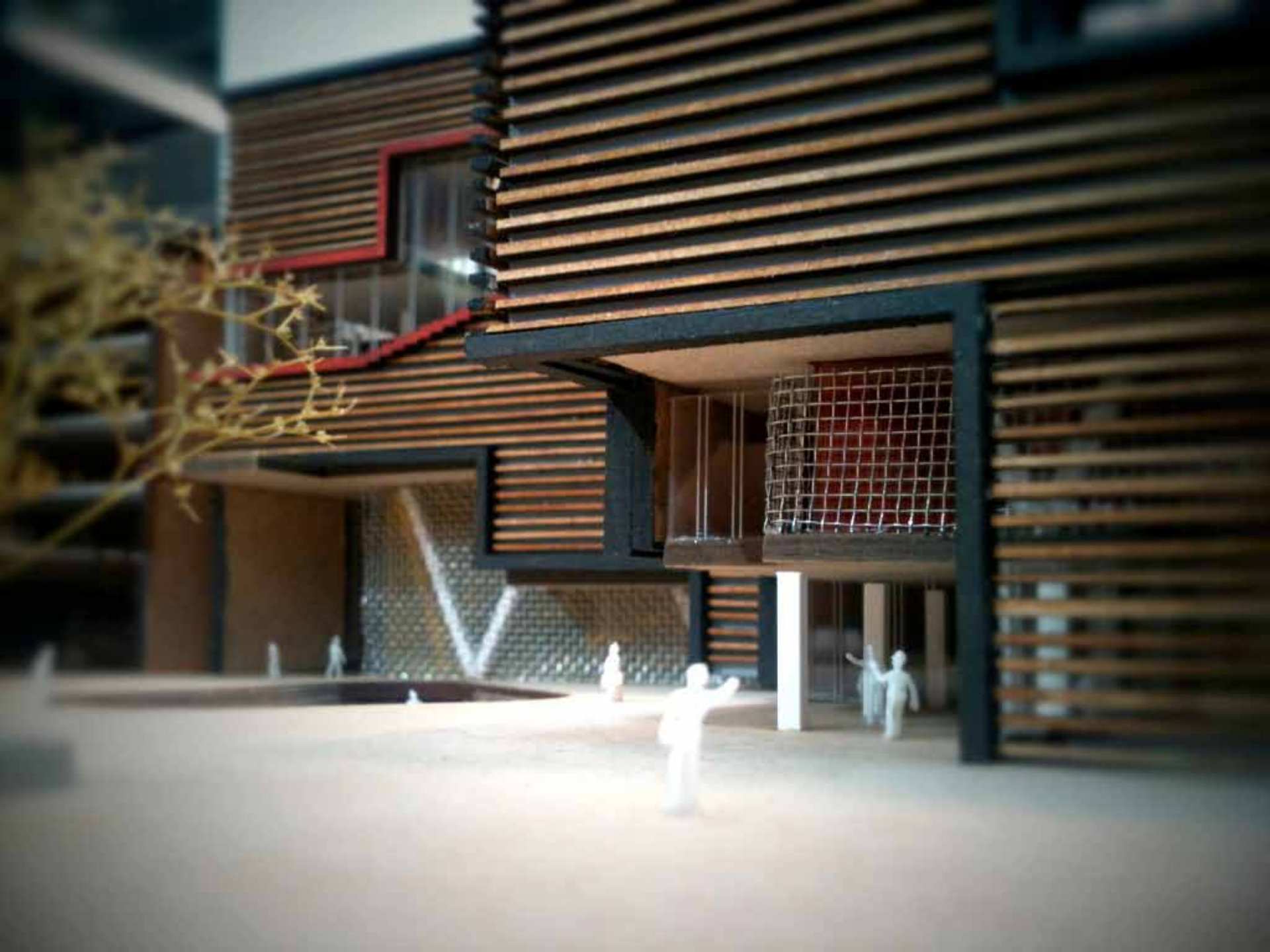



Design

1st Level

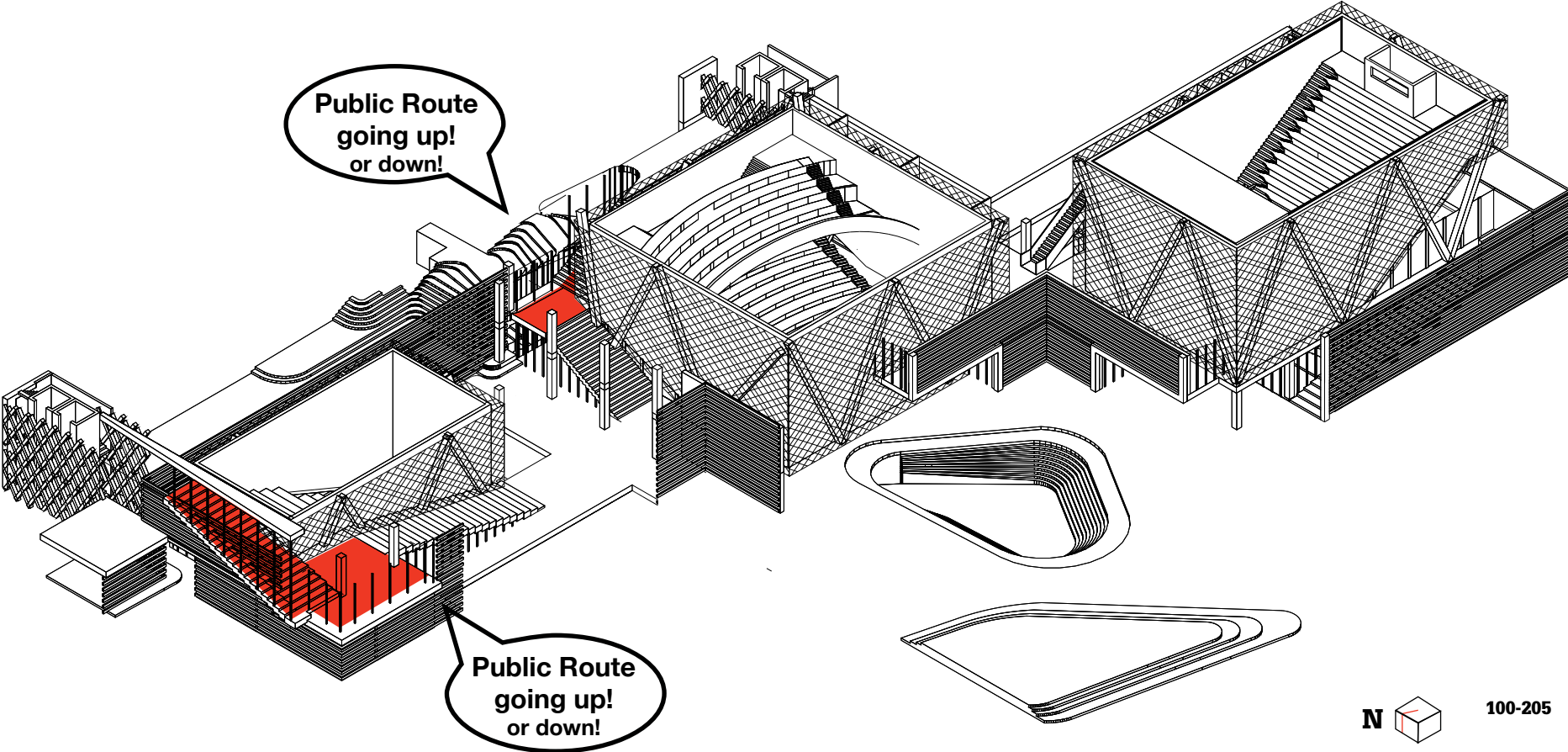

Design

2nd Level

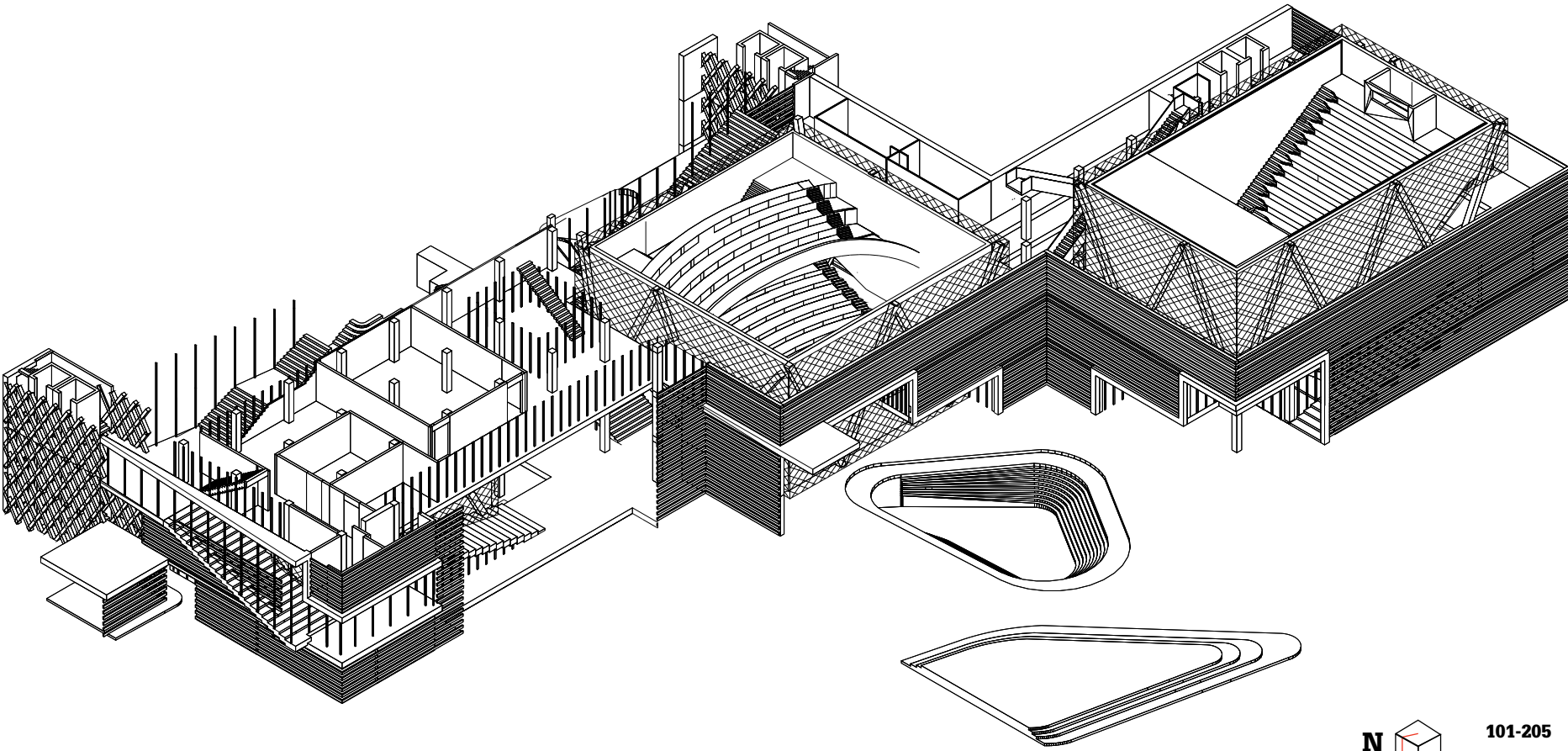

Design

2nd Level

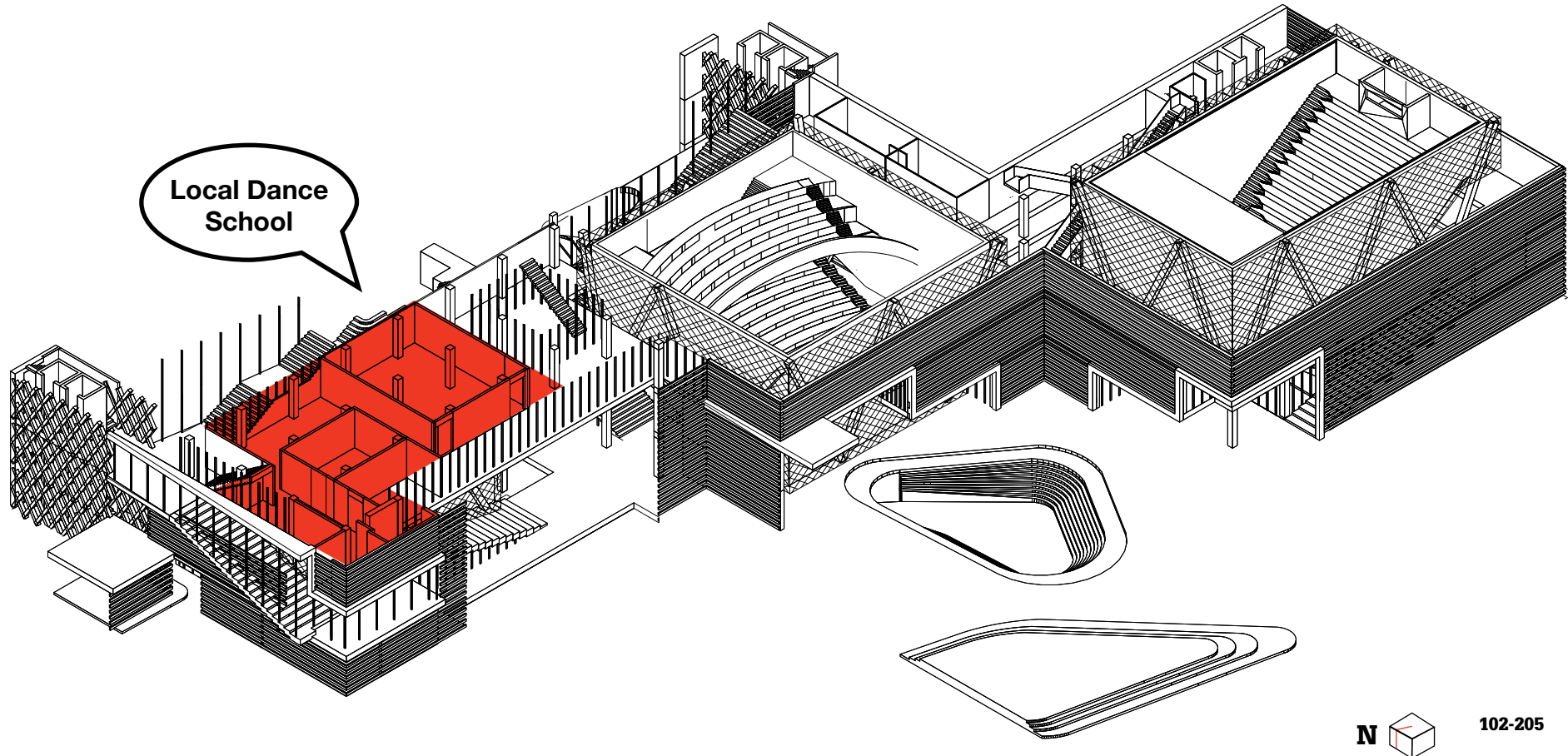

Design

2nd Level

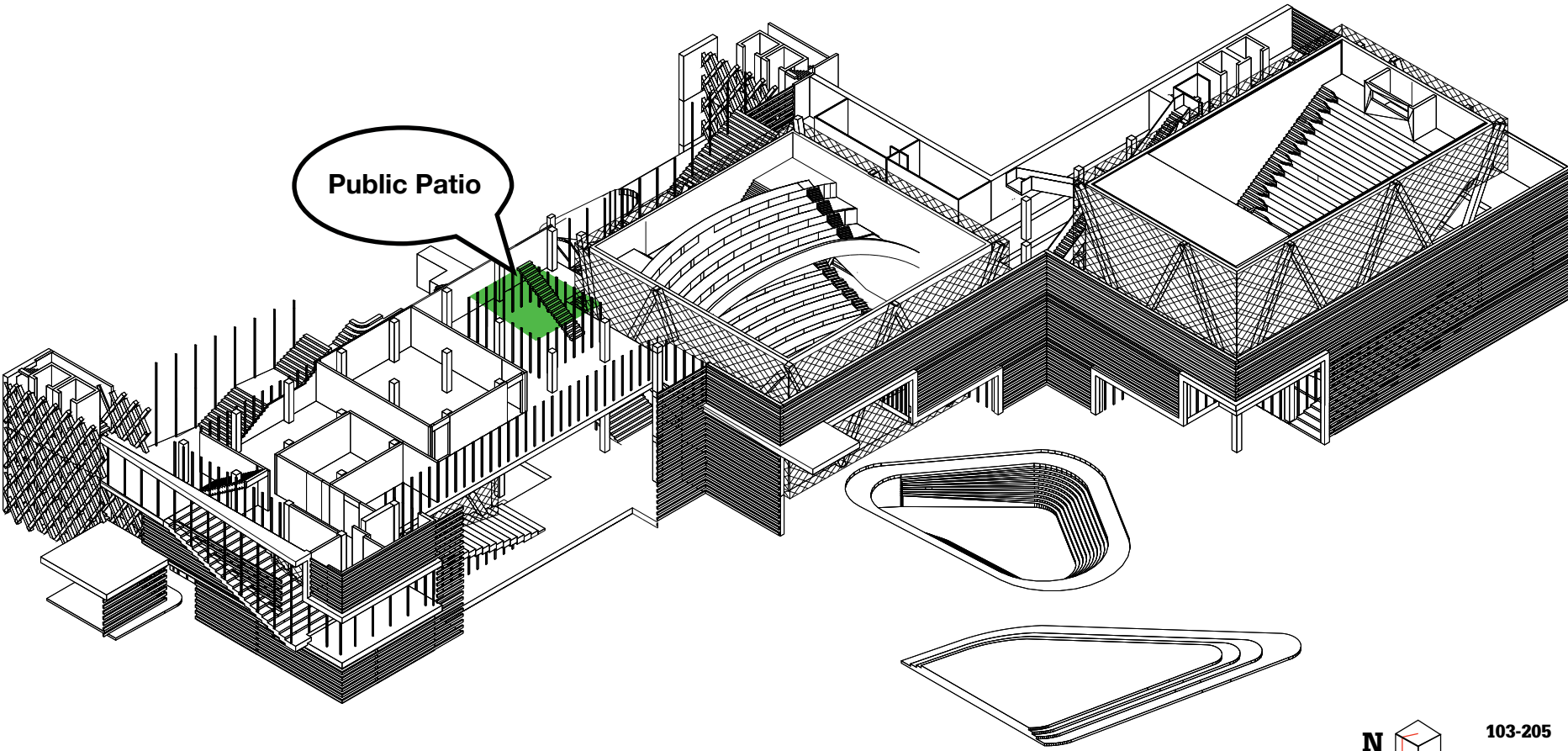

Design

2nd Level

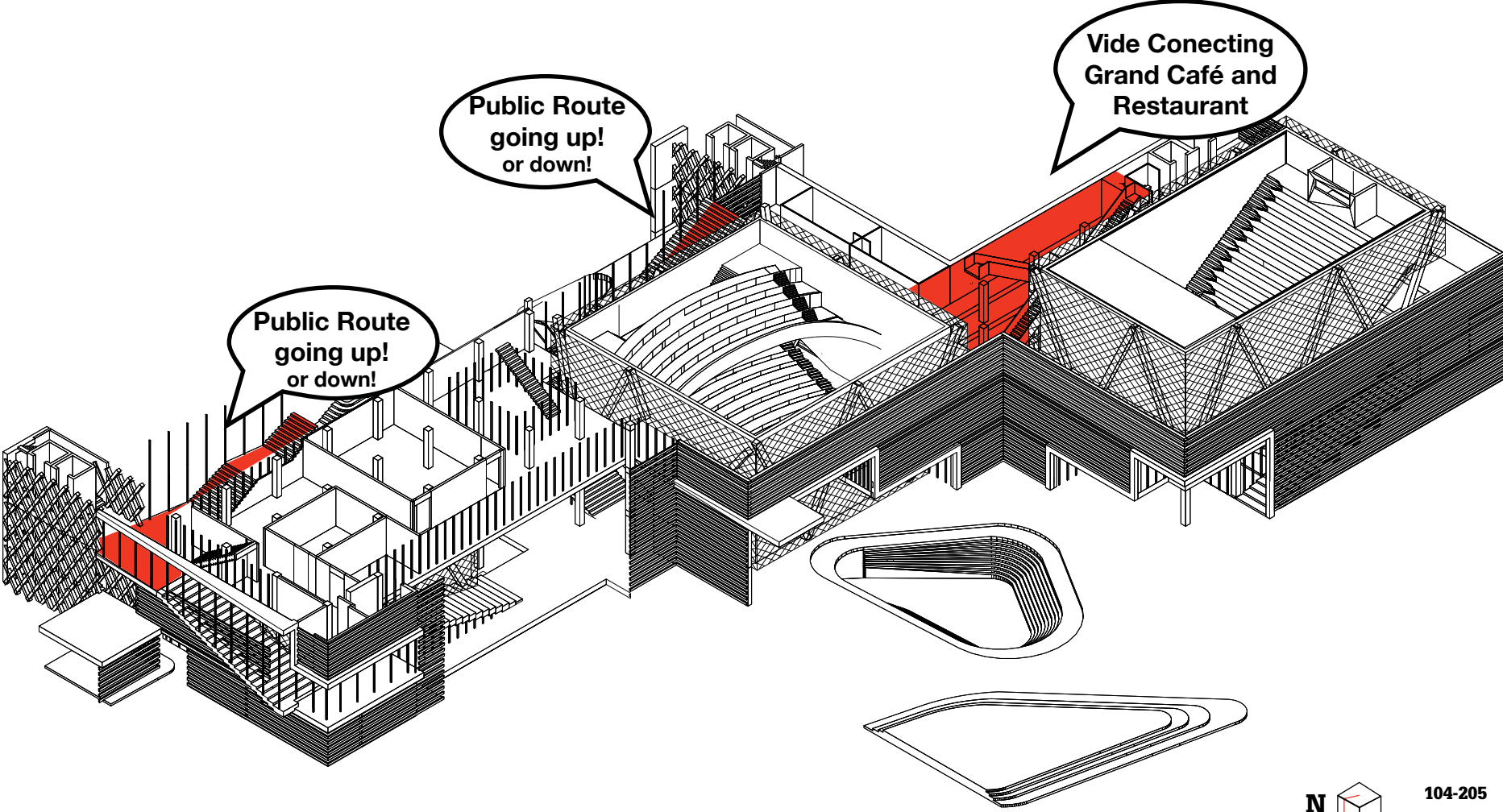

Public Route
going up!
or down!

Public Route
going up!
or down!

Vide Conecting
Grand Café and
Restaurant





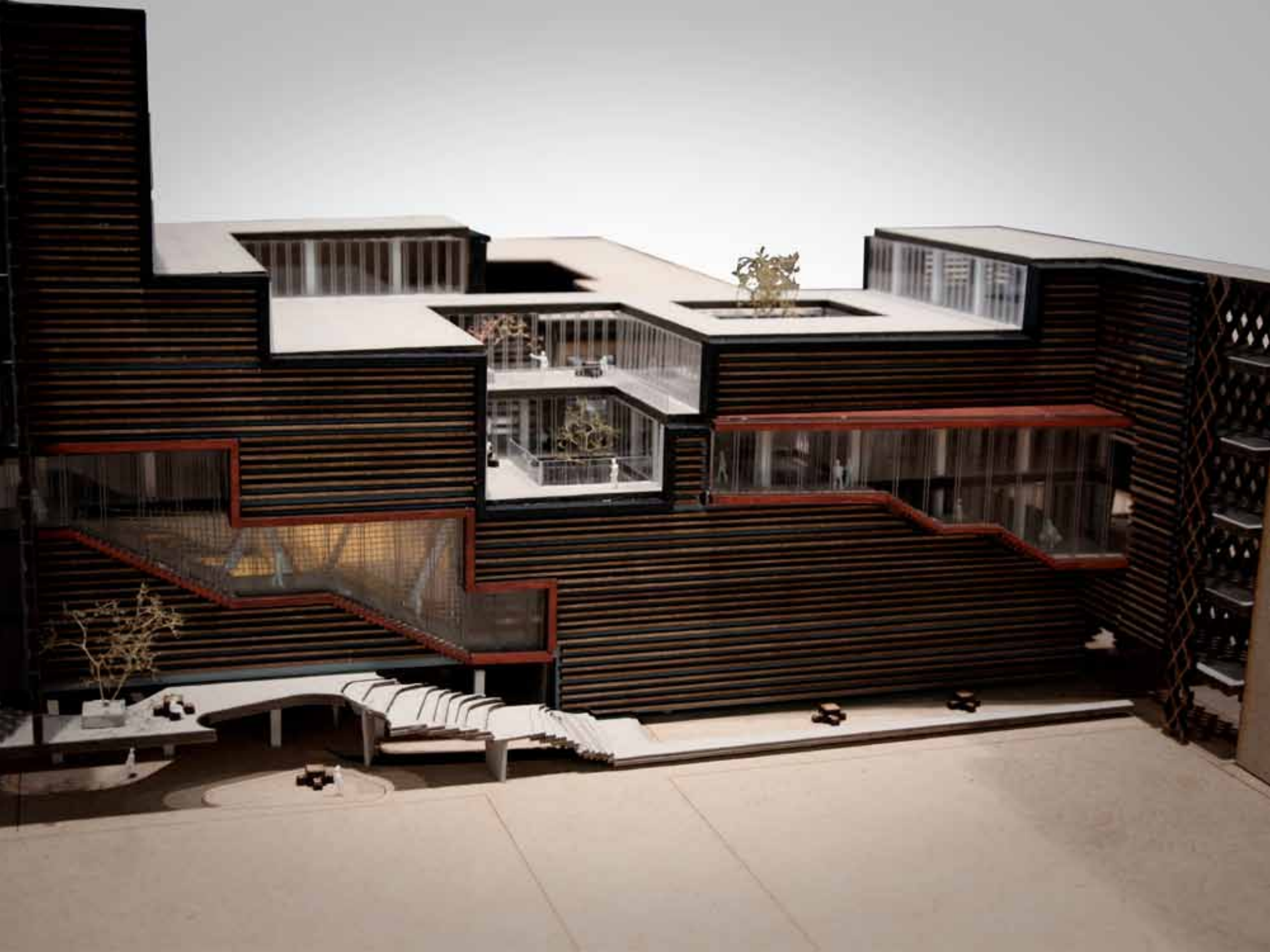





Design

3rd Level

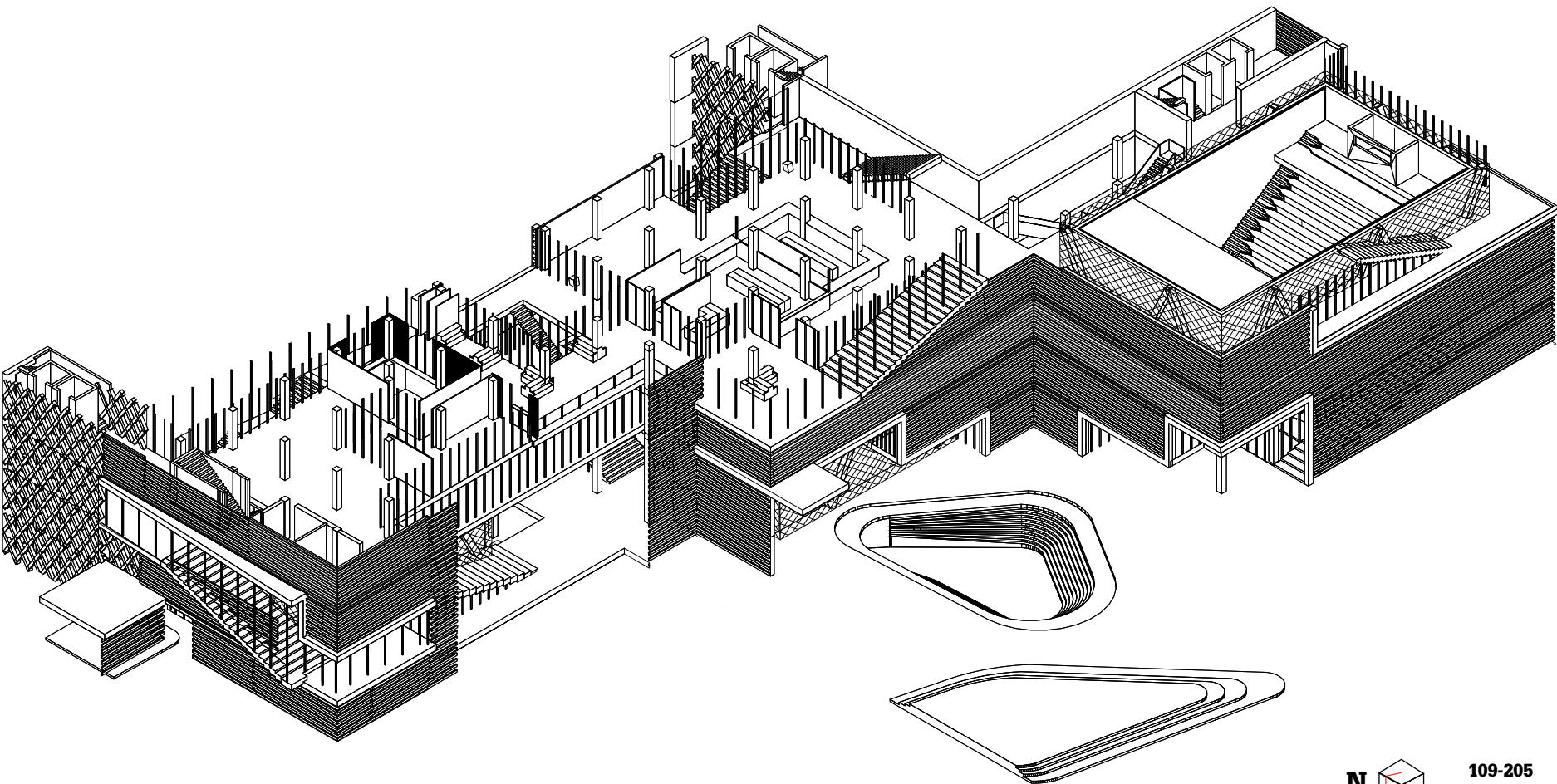

Design

3rd Level

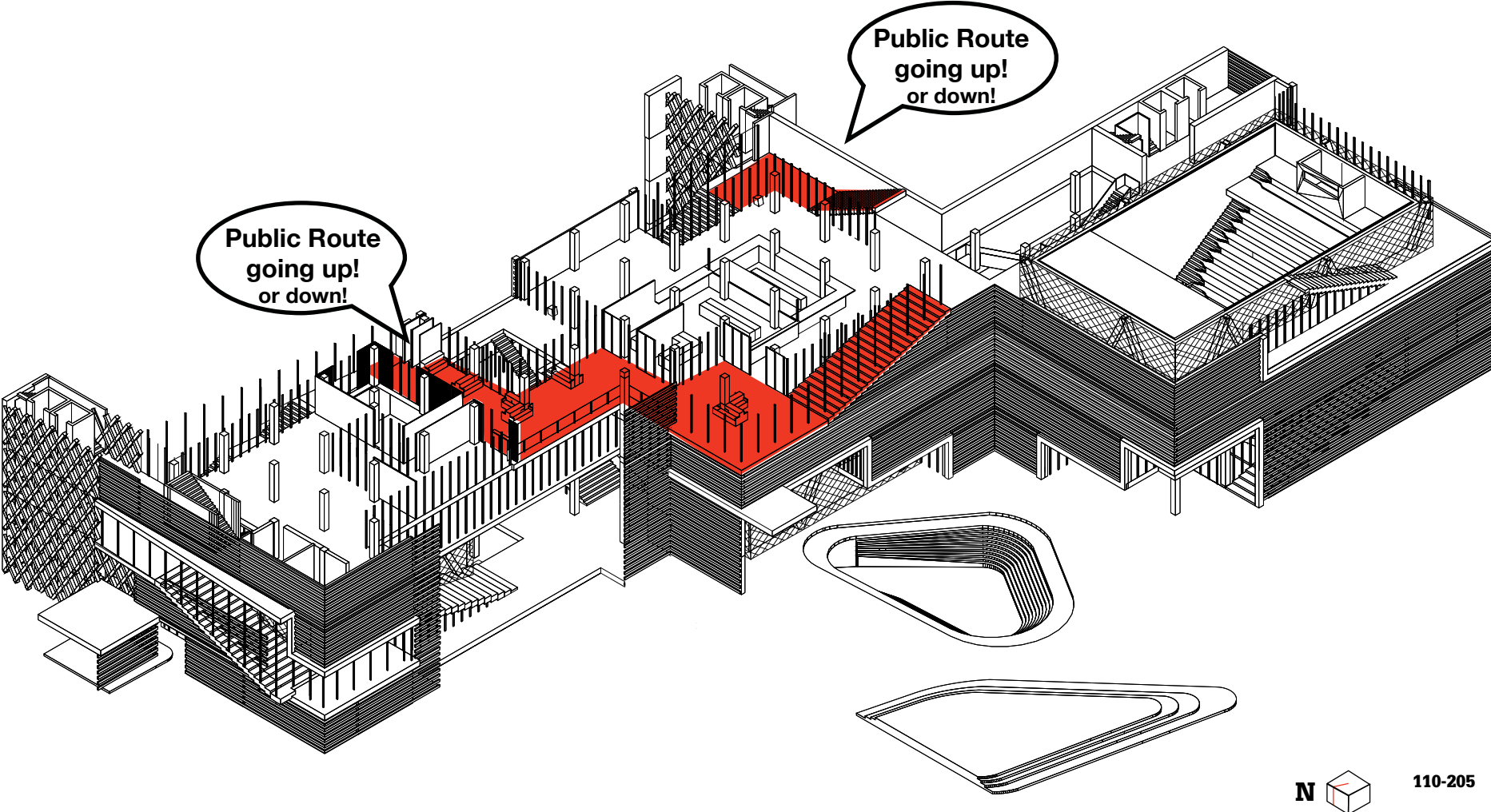

Public Route going up!
or down!

Public Route going up!
or down!



Design

3rd Level

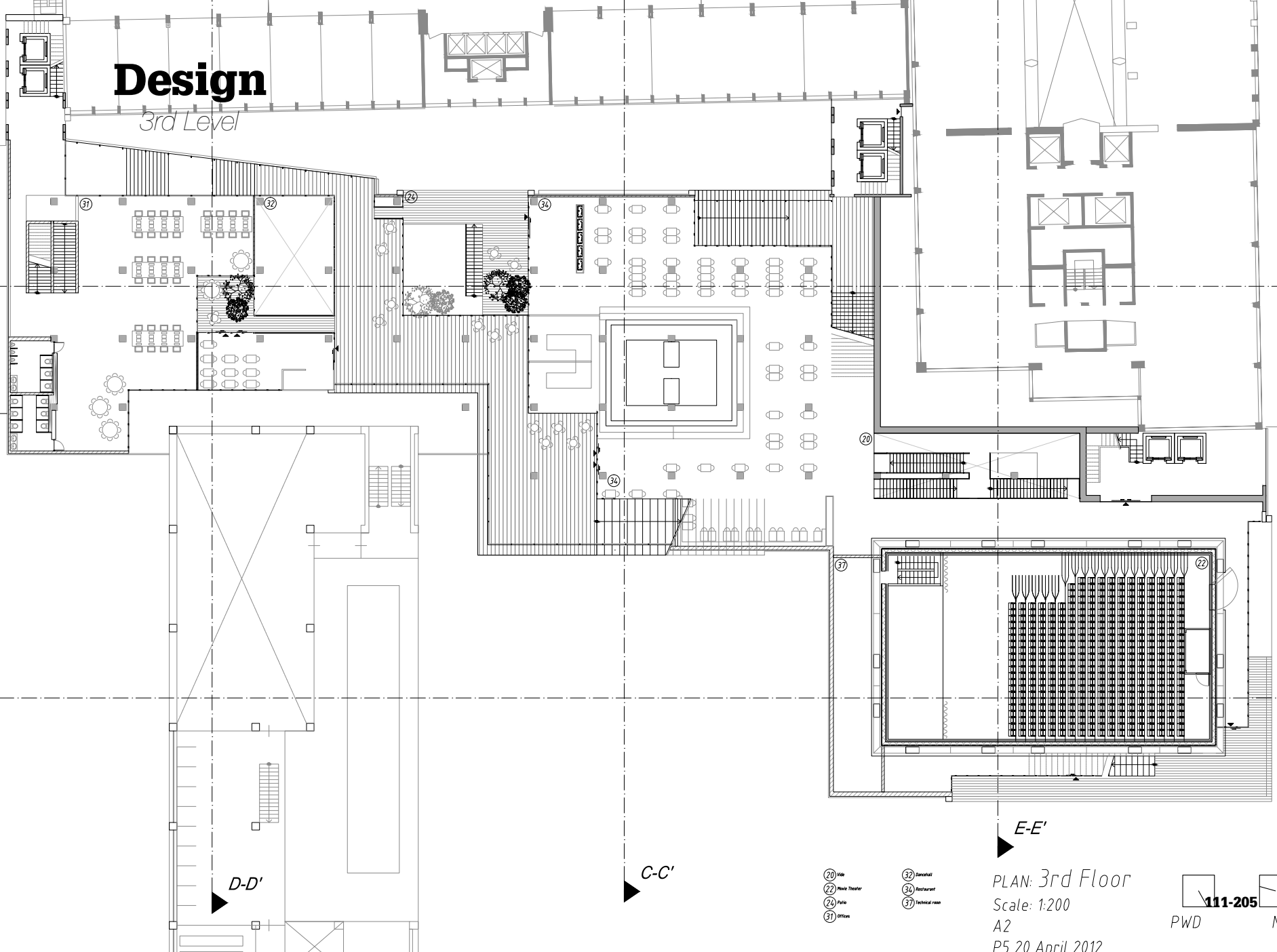

- 20 Use
- 22 Male Theater
- 24 Patio
- 37 Office
- 32 Reception
- 34 Restaurant
- 37 Technical room

PLAN: 3rd Floor
Scale: 1:200
A2
P5 20 April 2012







Design

3rd Level

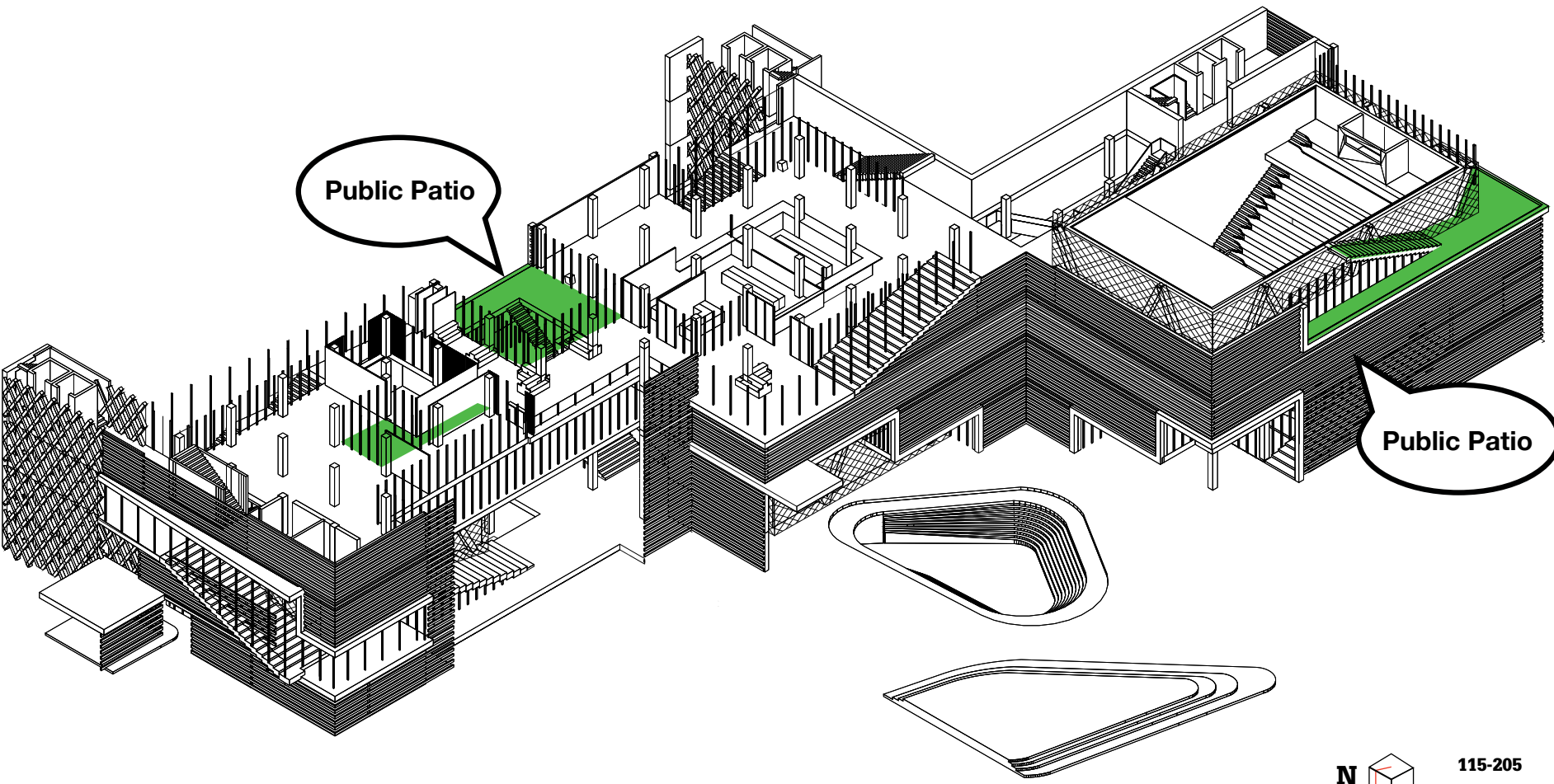













Design

3rd Level

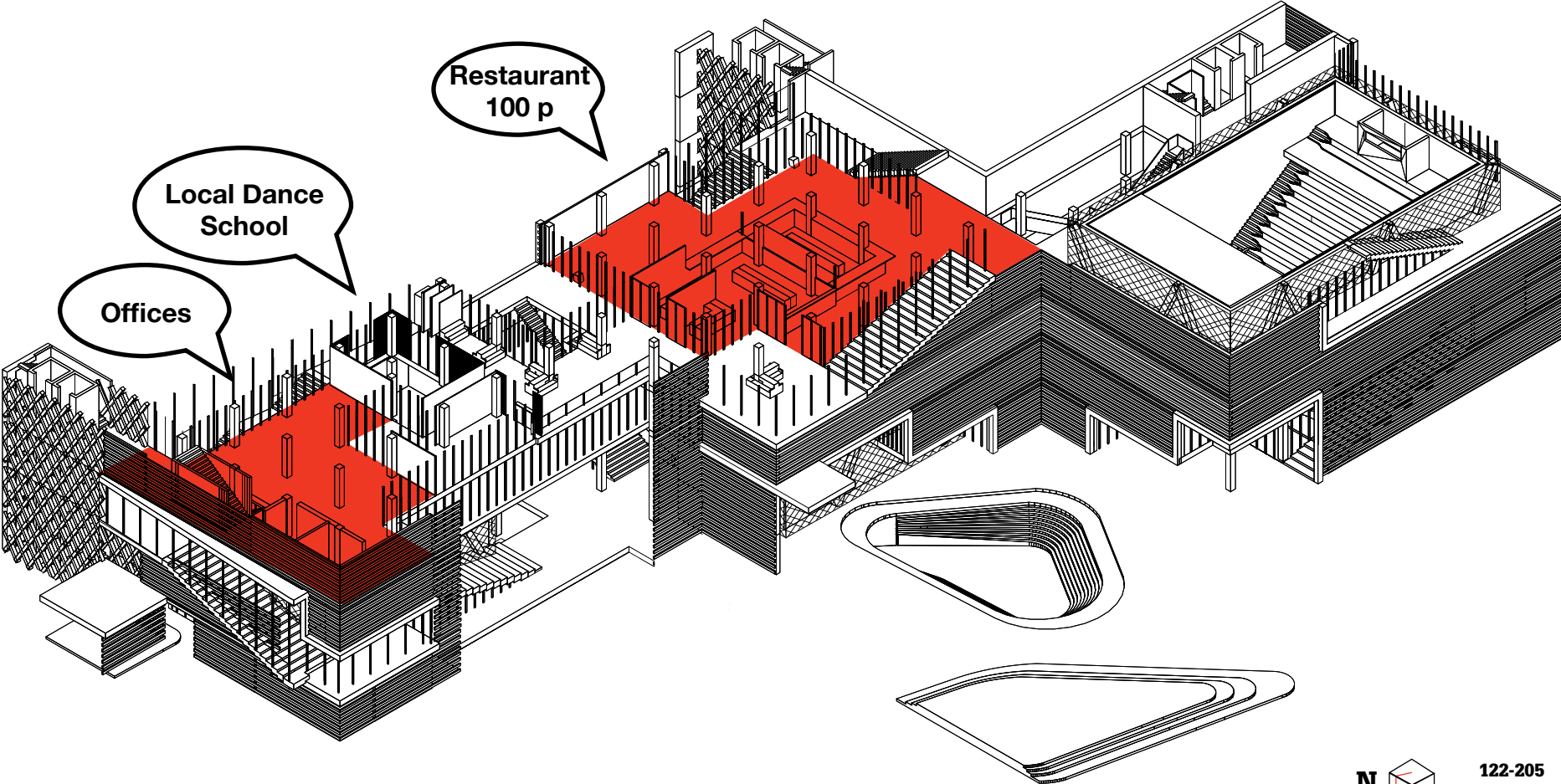

Design

4th Level

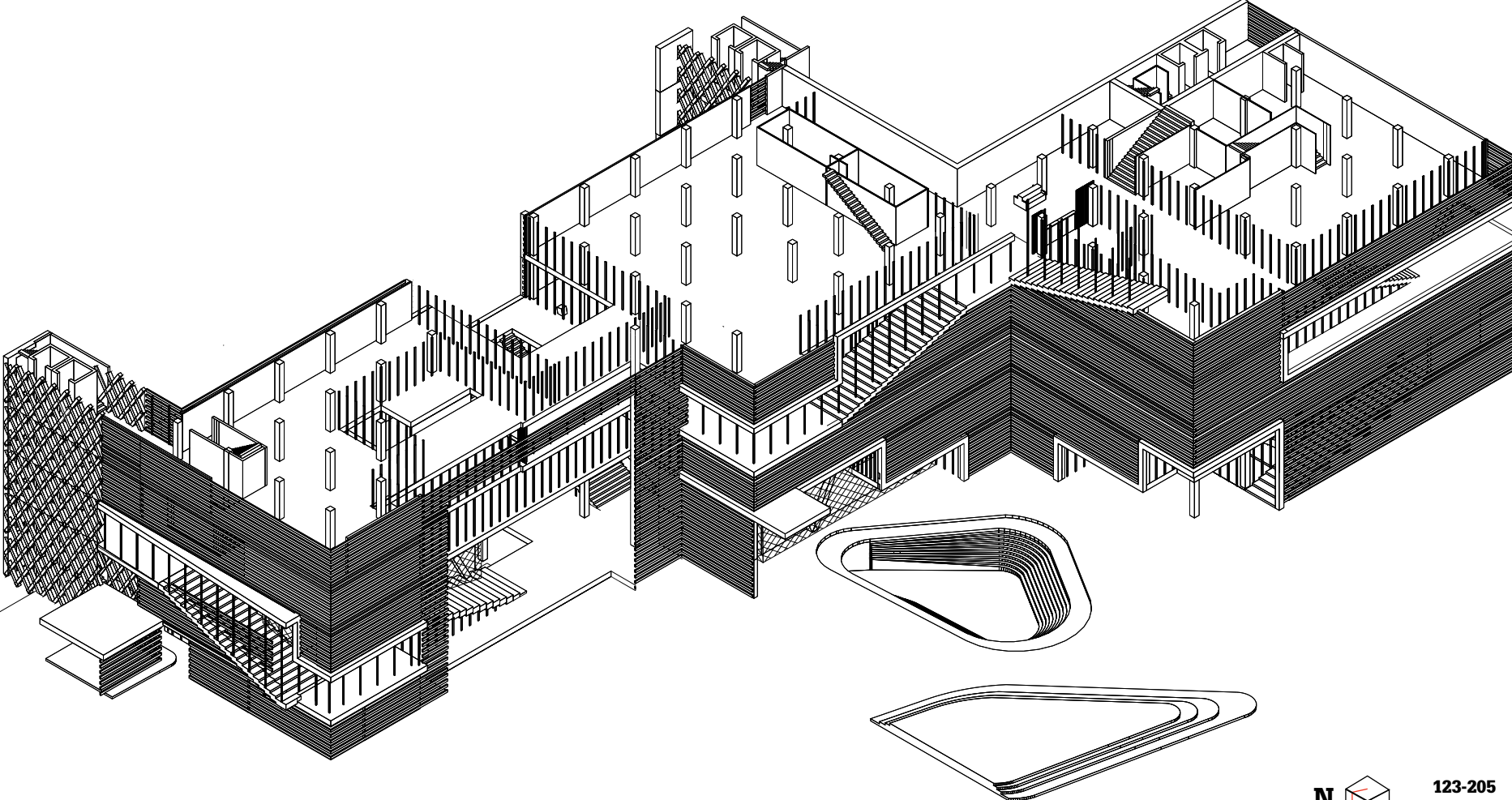

Design

4th Level

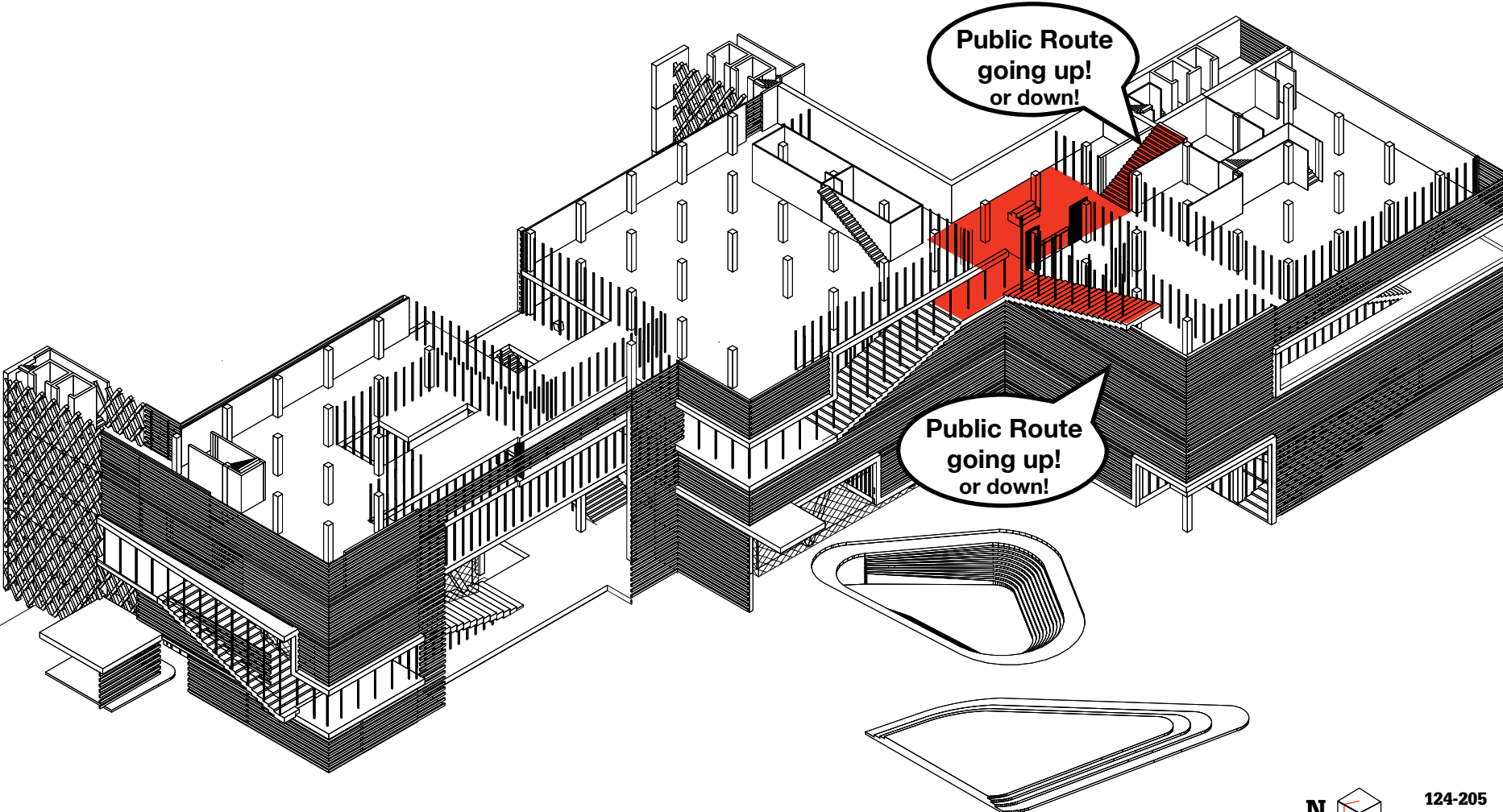

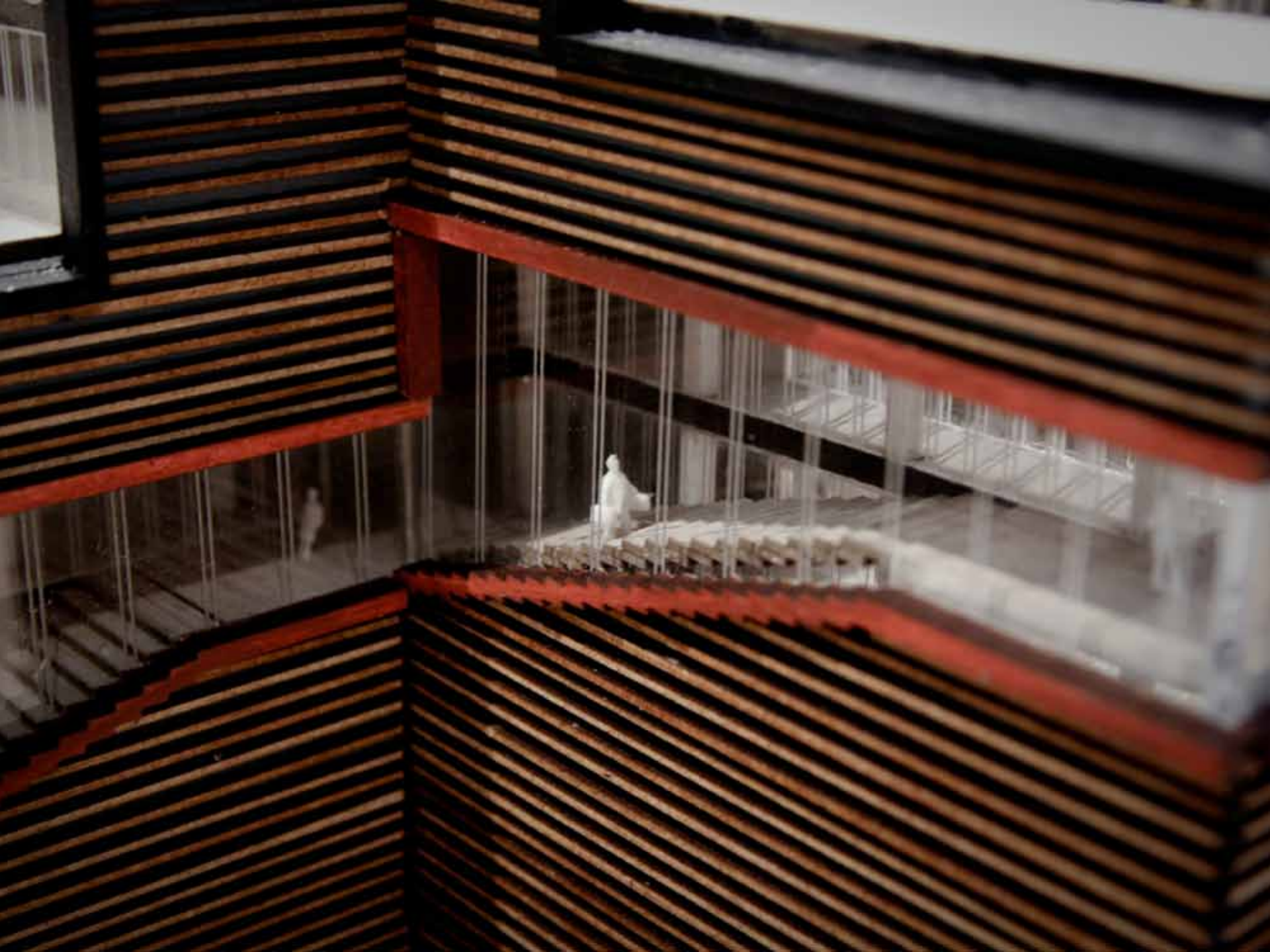

Design

4th Level

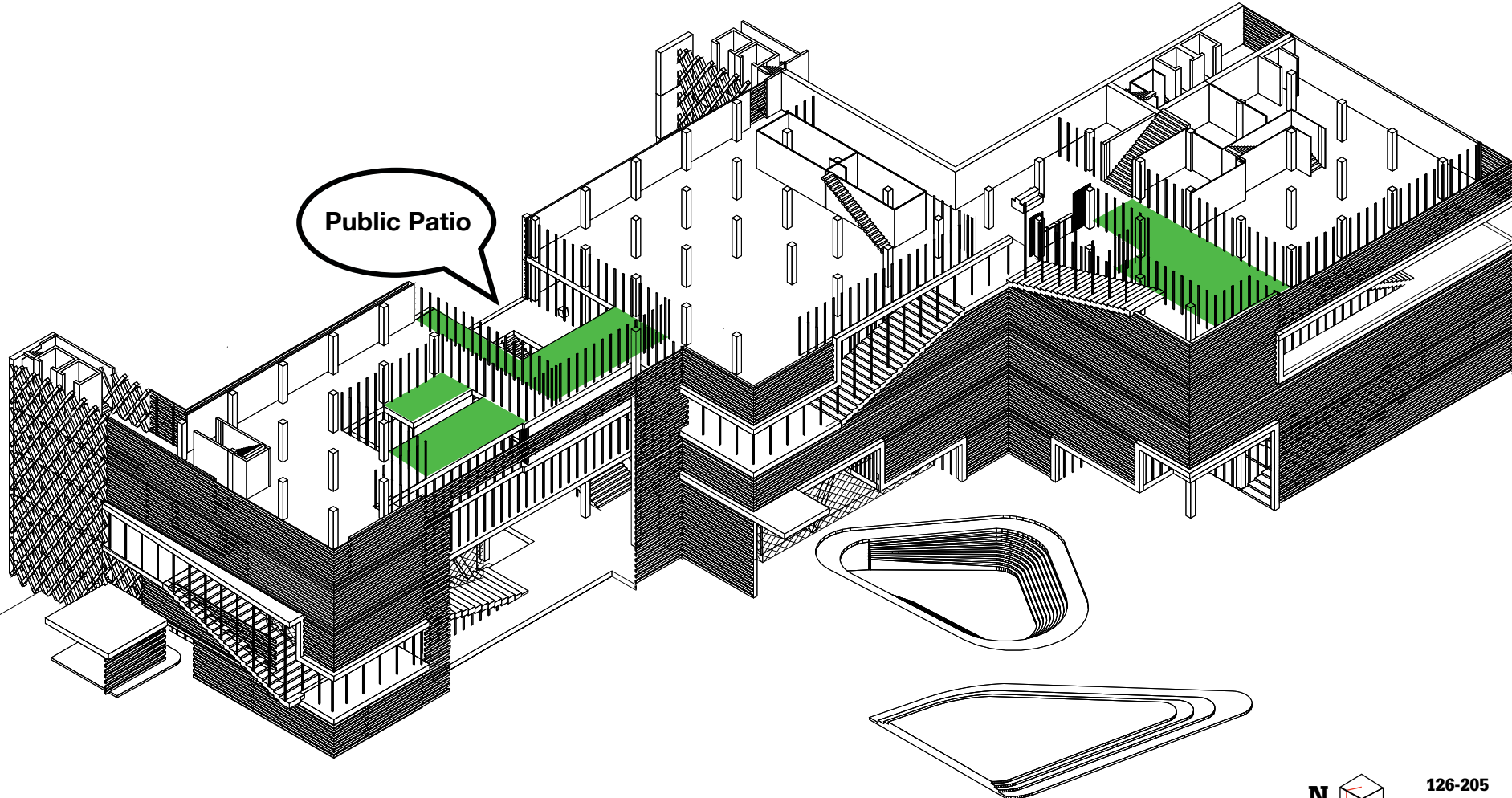

Public Patio







Design

4th Level

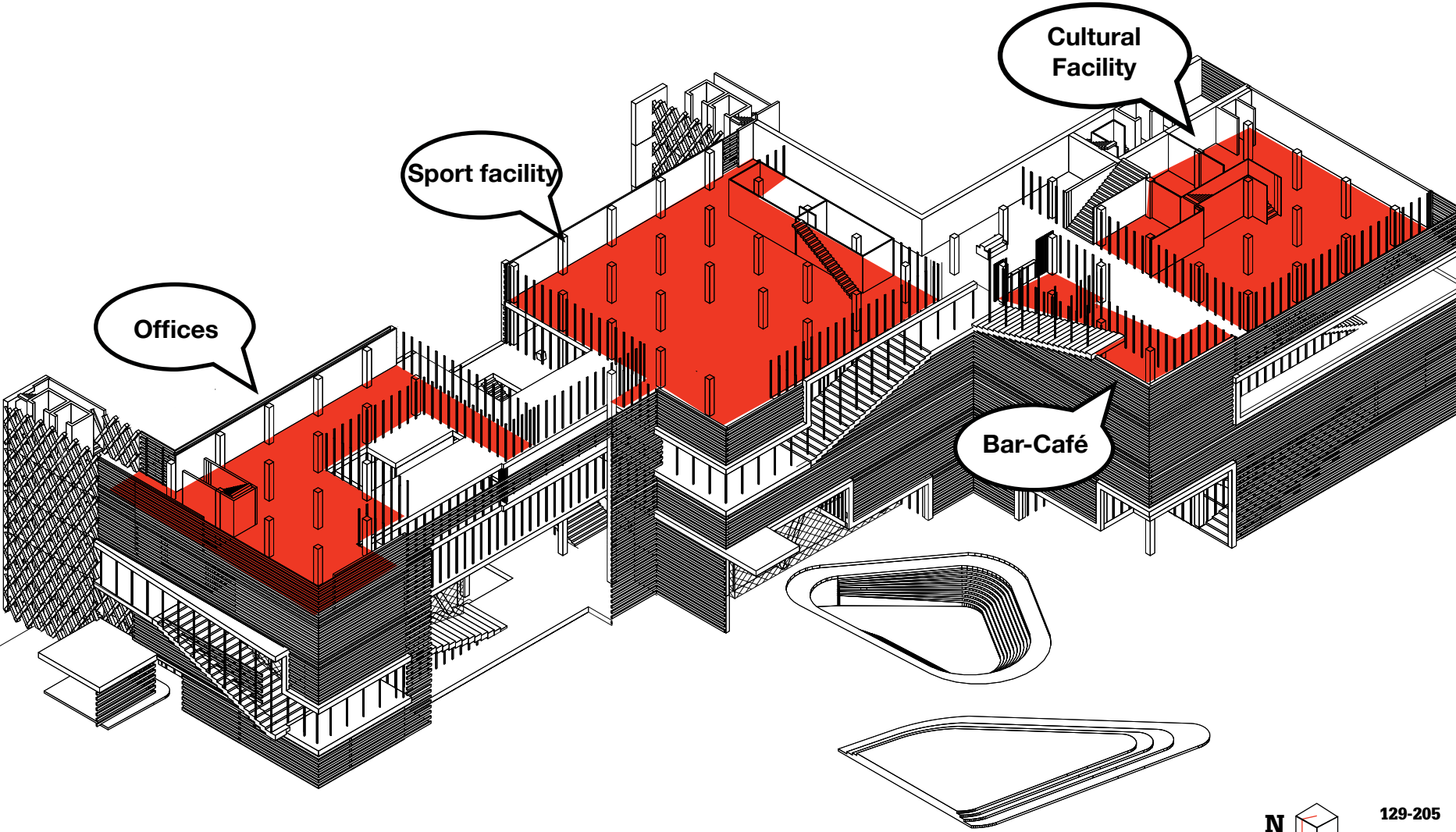



Design

5th Level

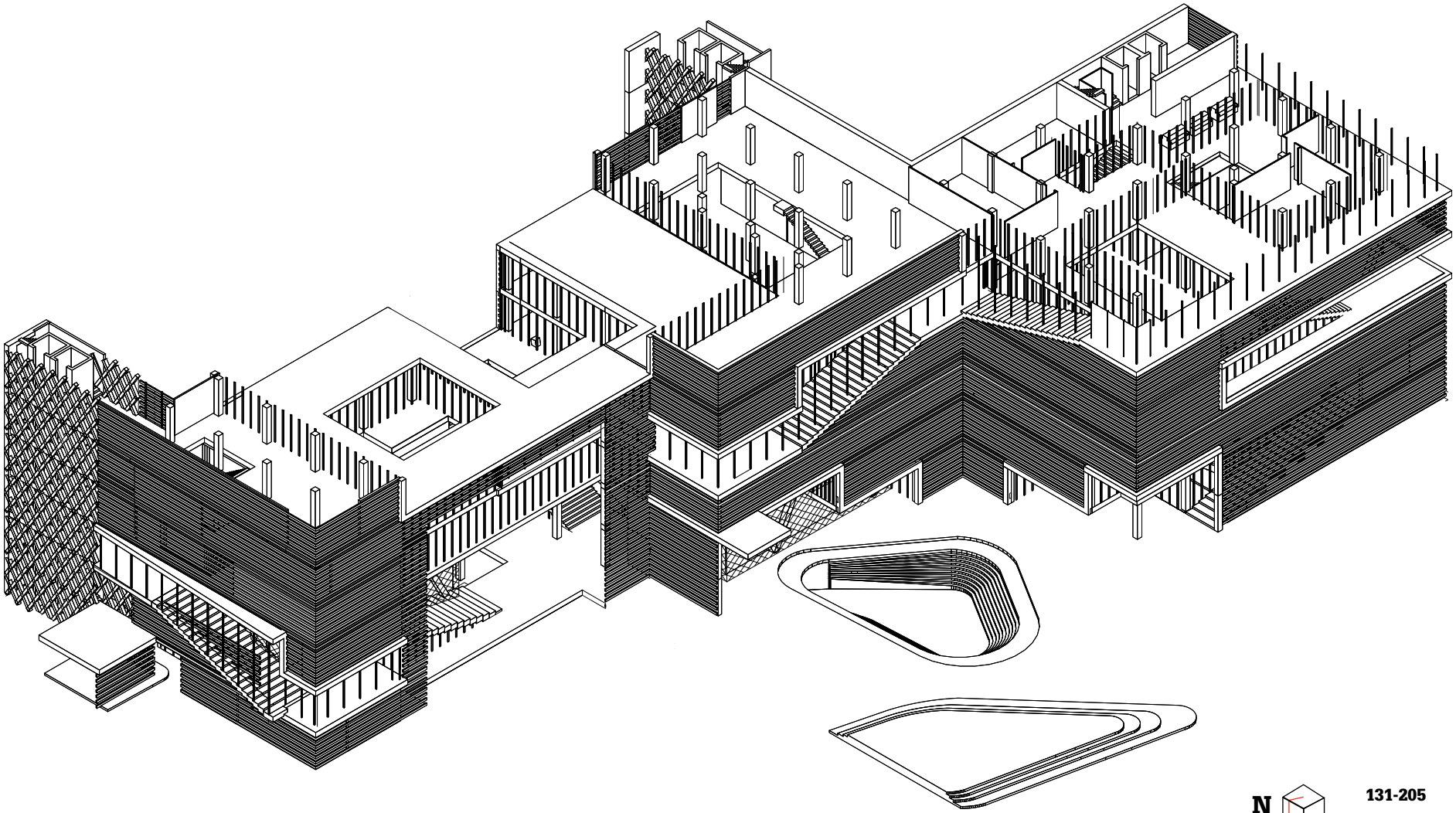

Design

5th Level

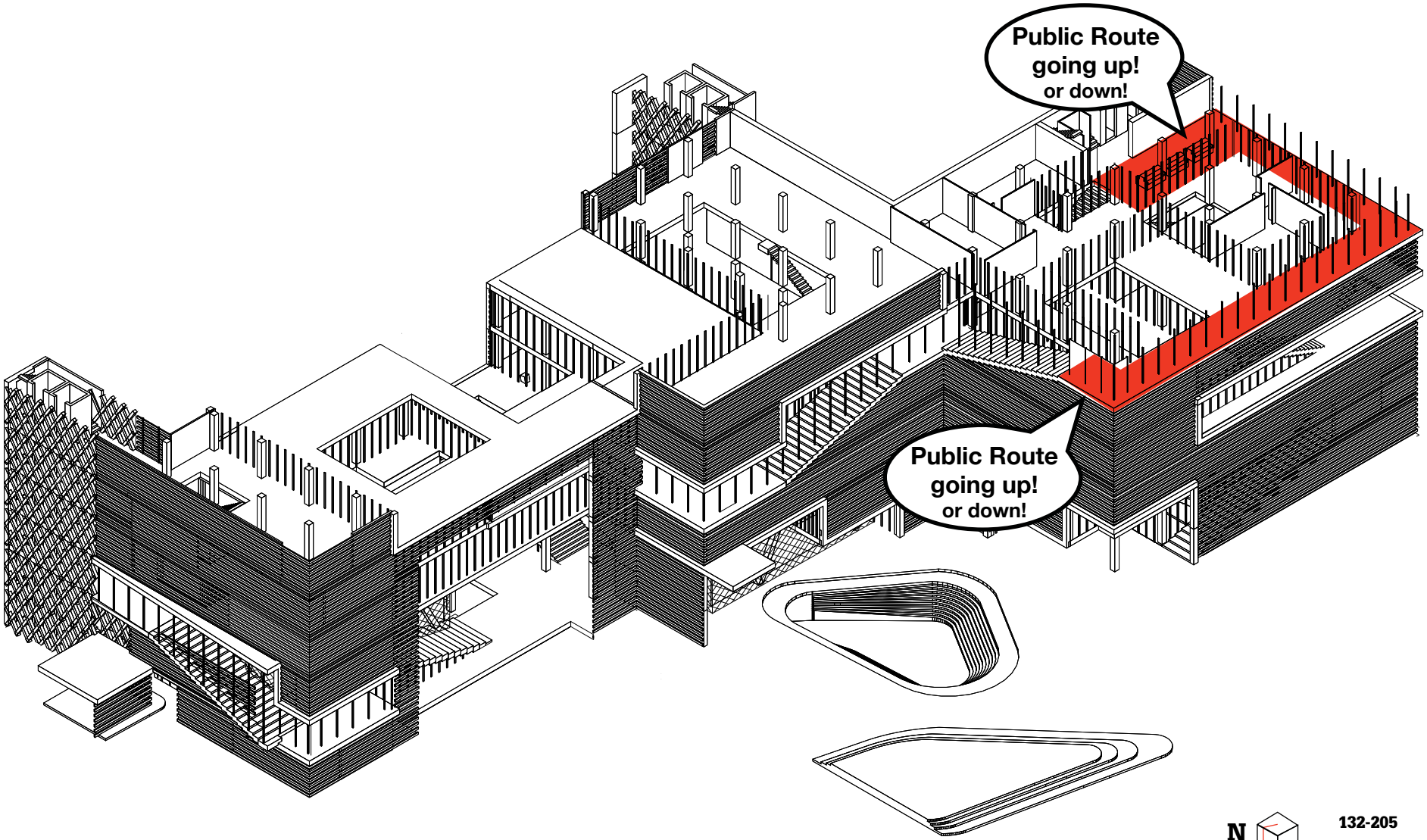

Public Route
going up!
or down!

Public Route
going up!
or down!



Design

5th Level

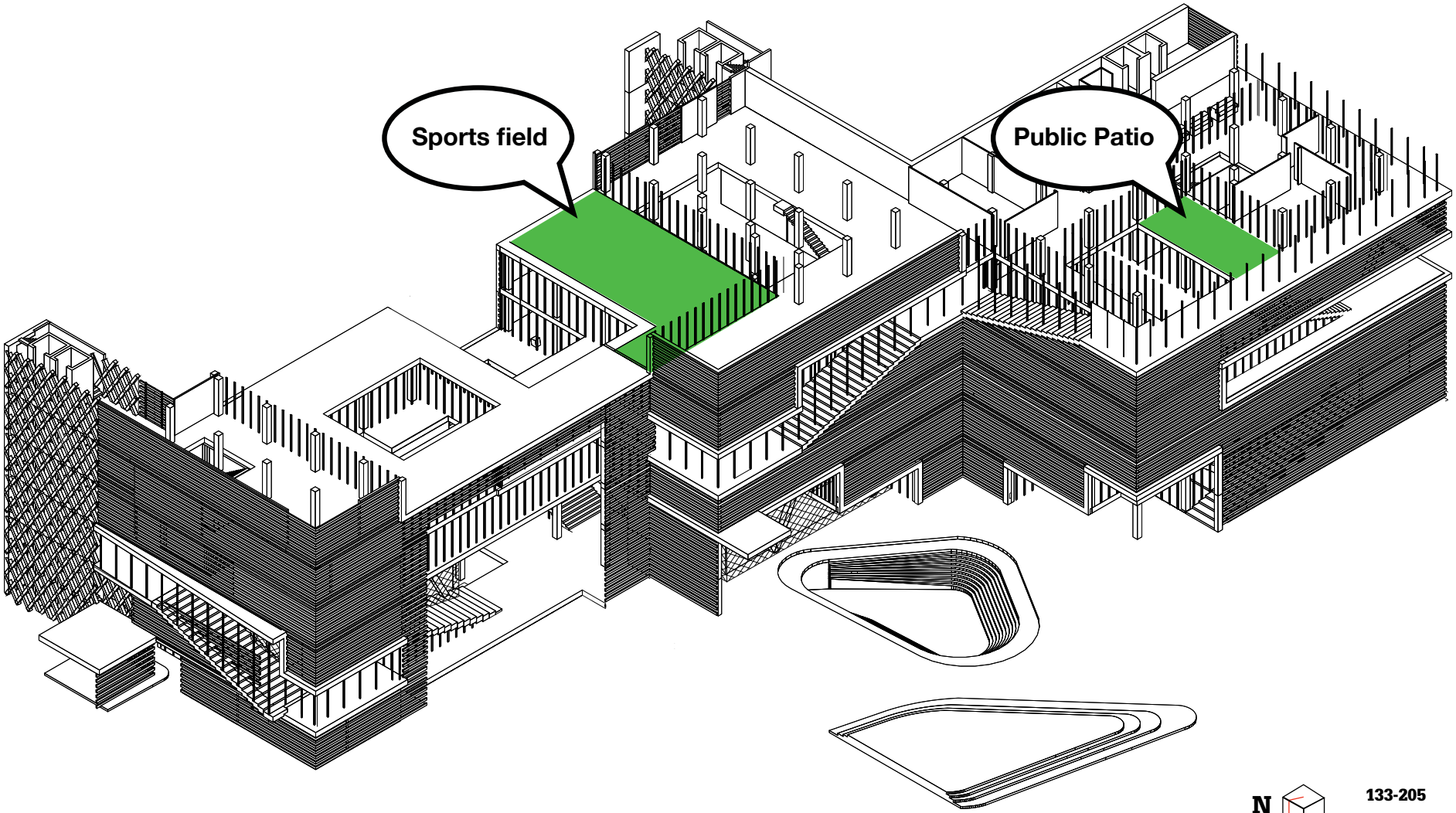

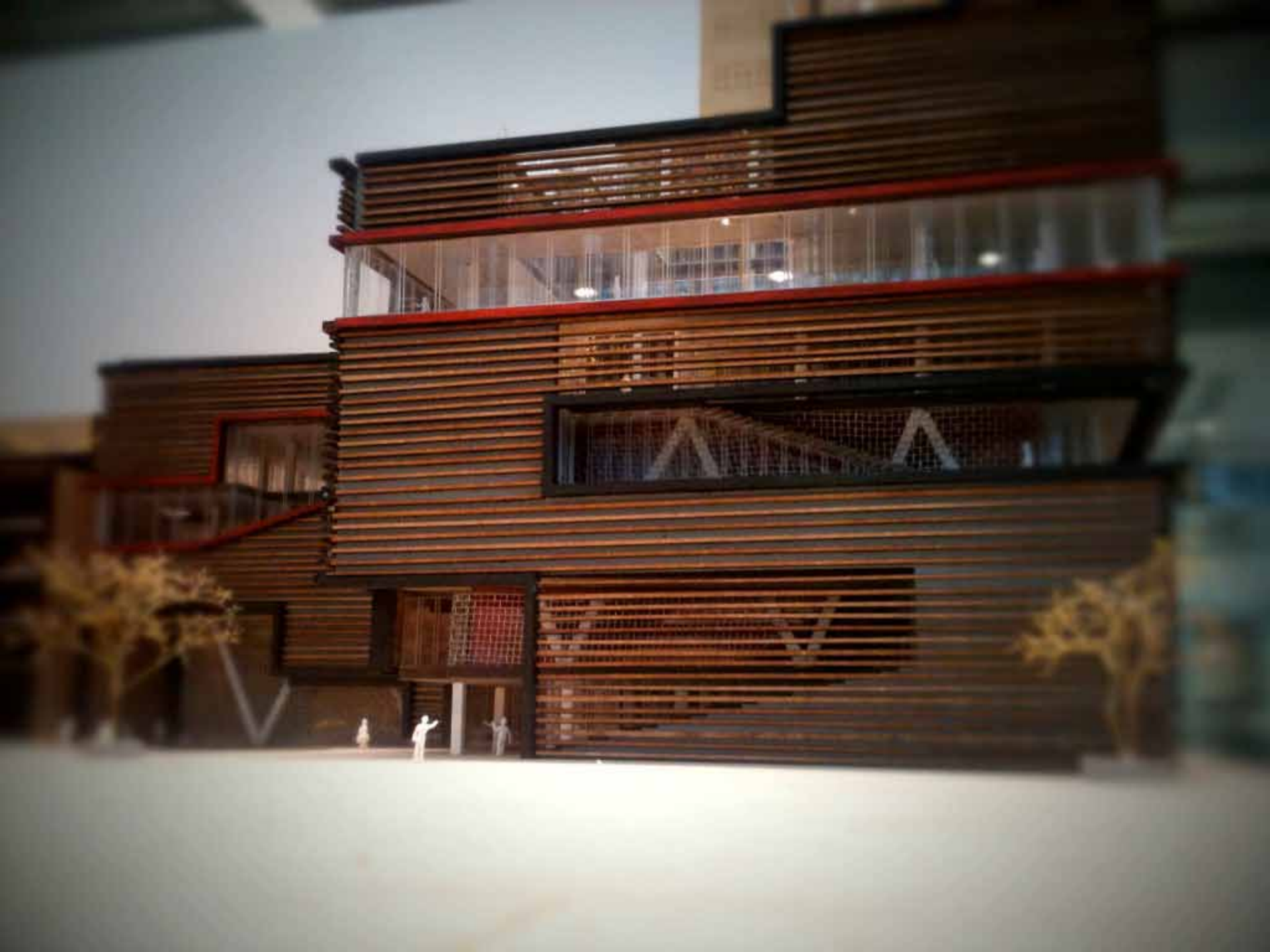



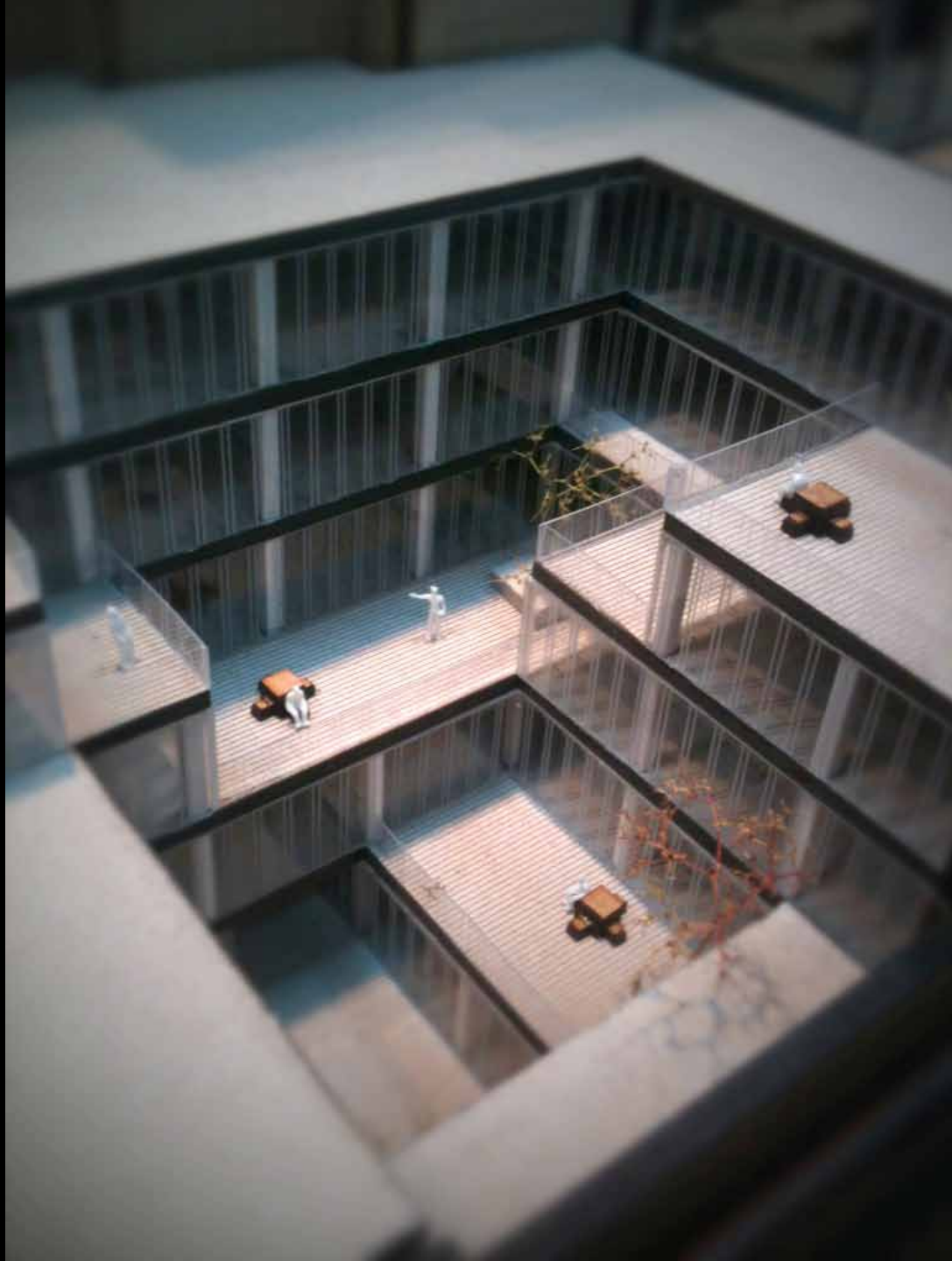

Design

5th Level

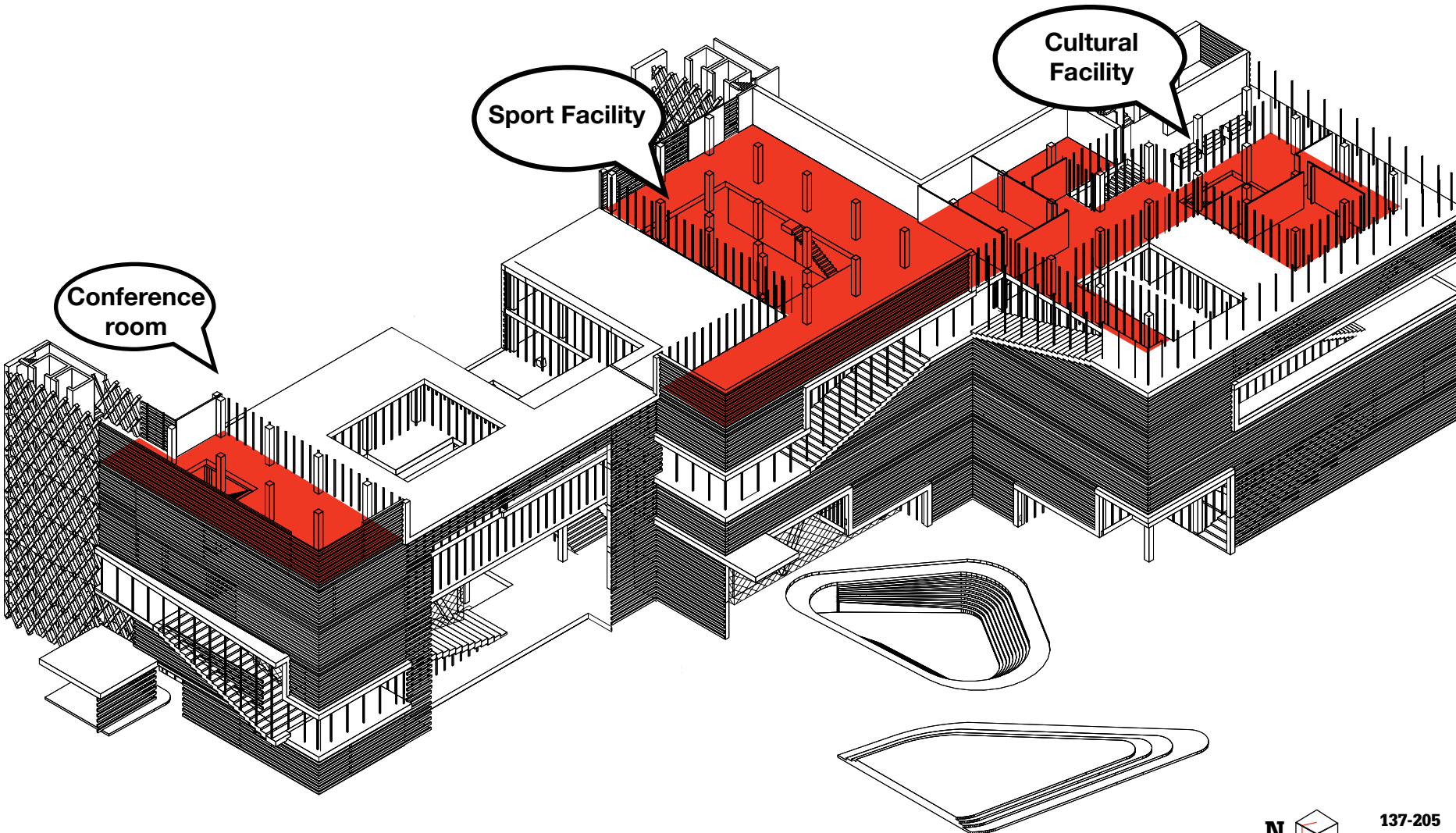

Design

5th Level

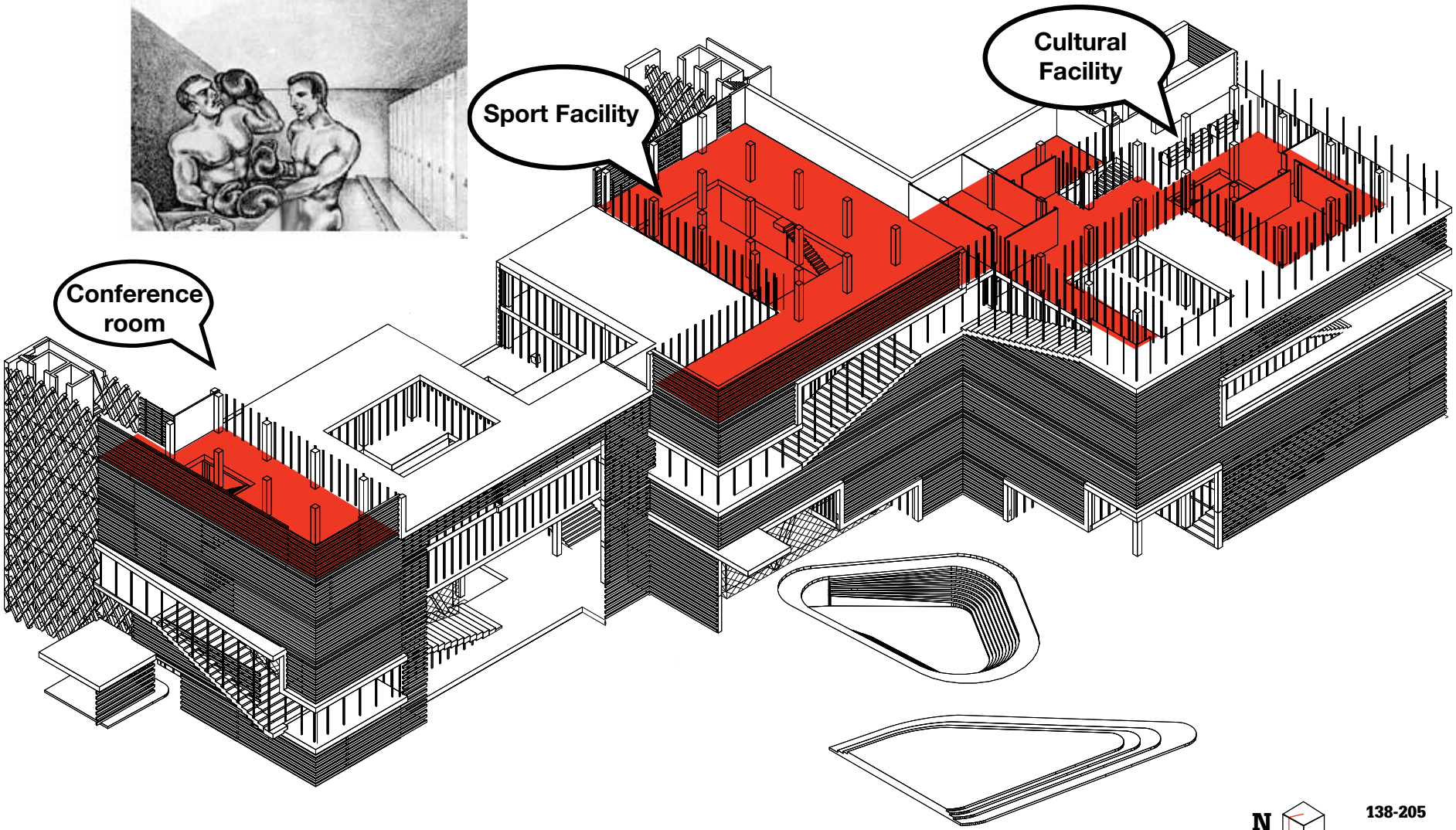

Design

6th Level

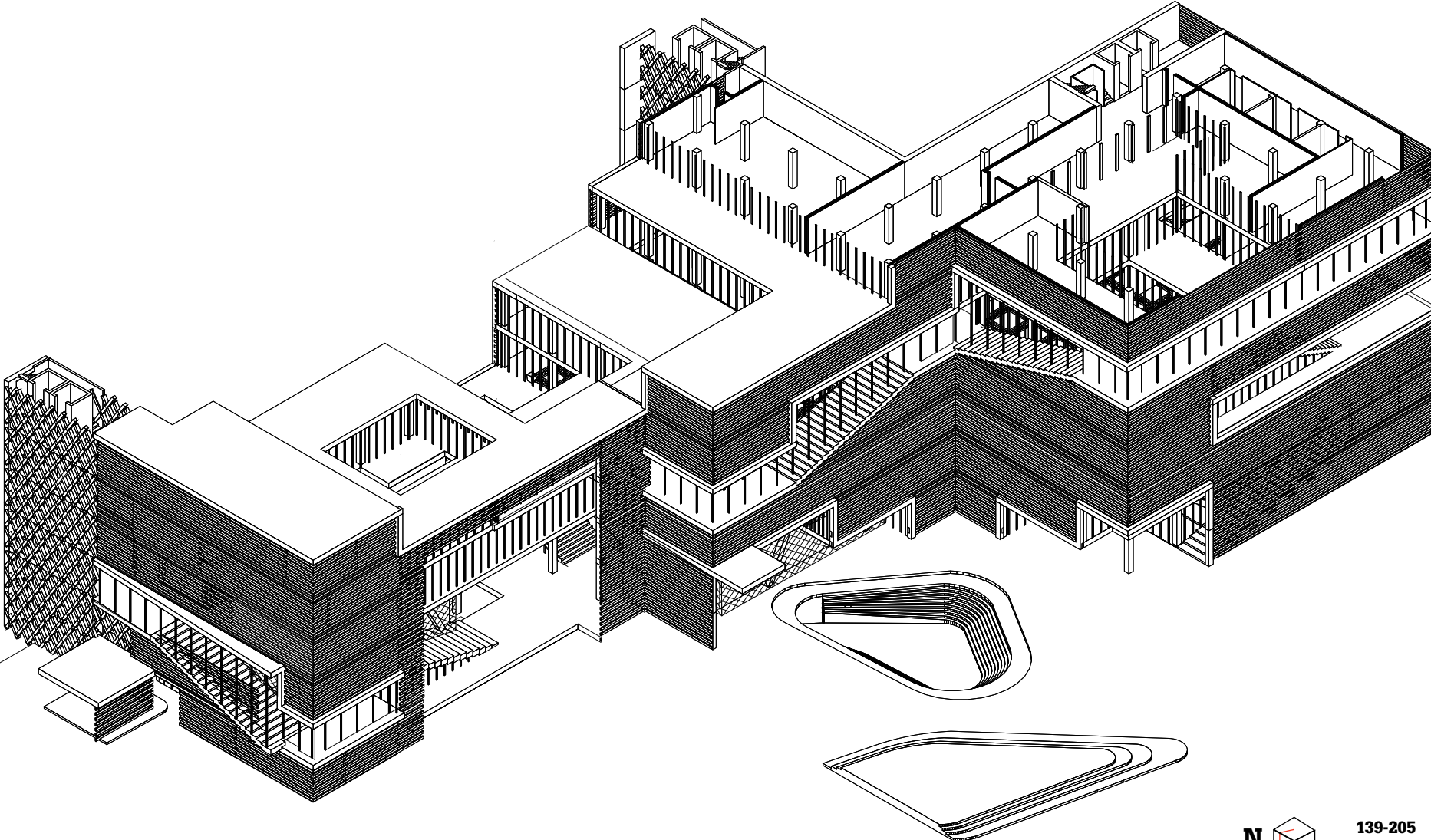

Design

6th Level

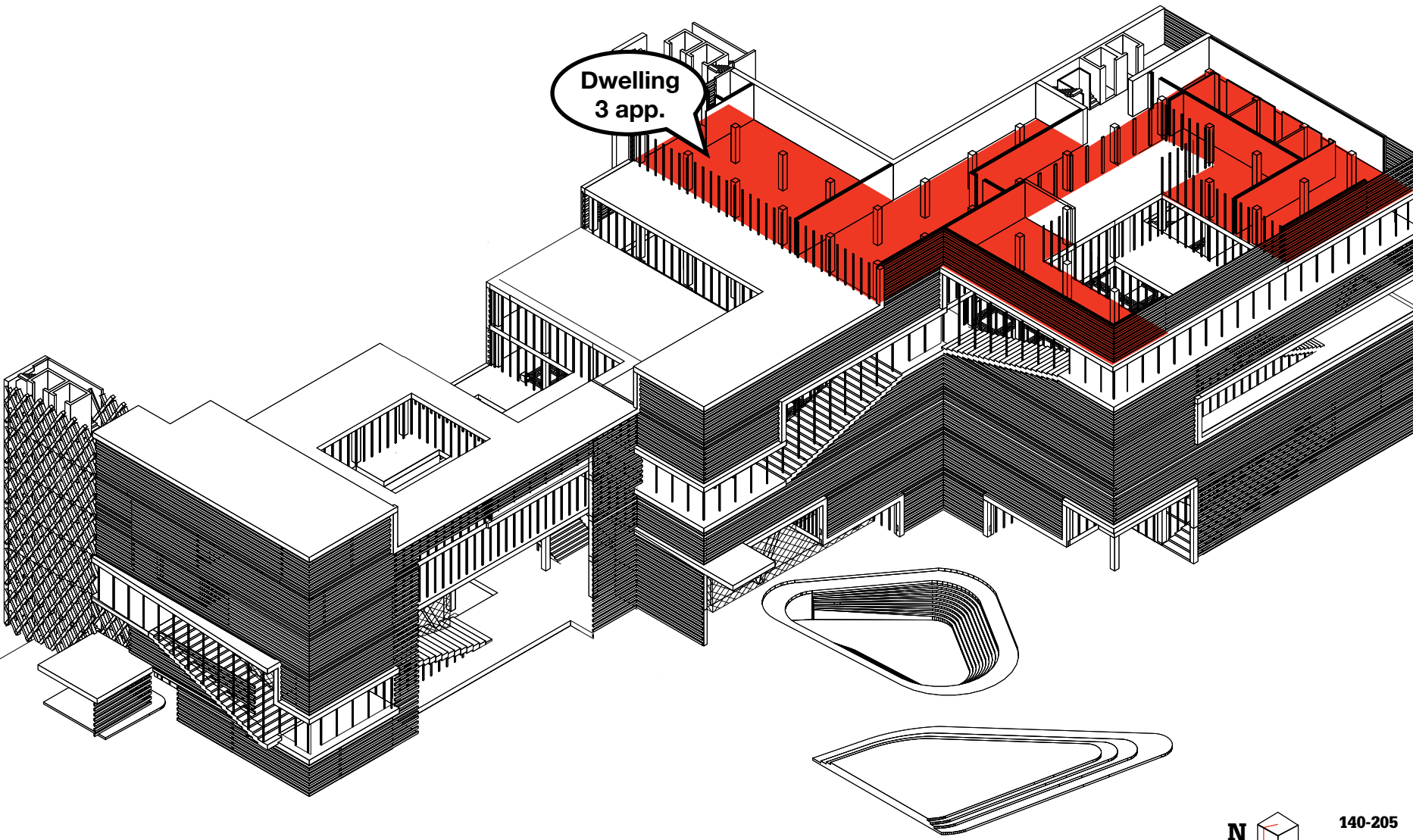

Design

6th Level

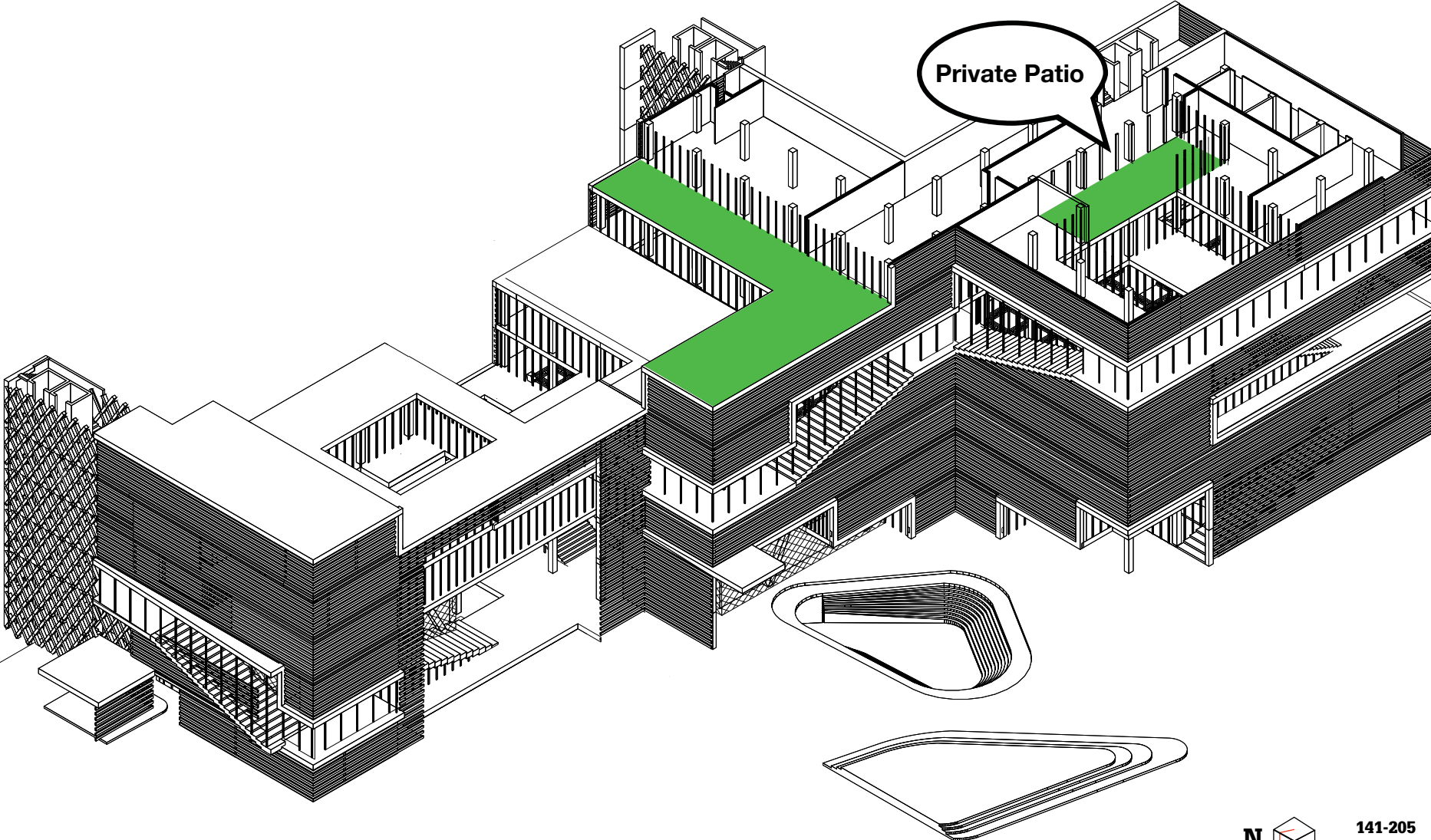

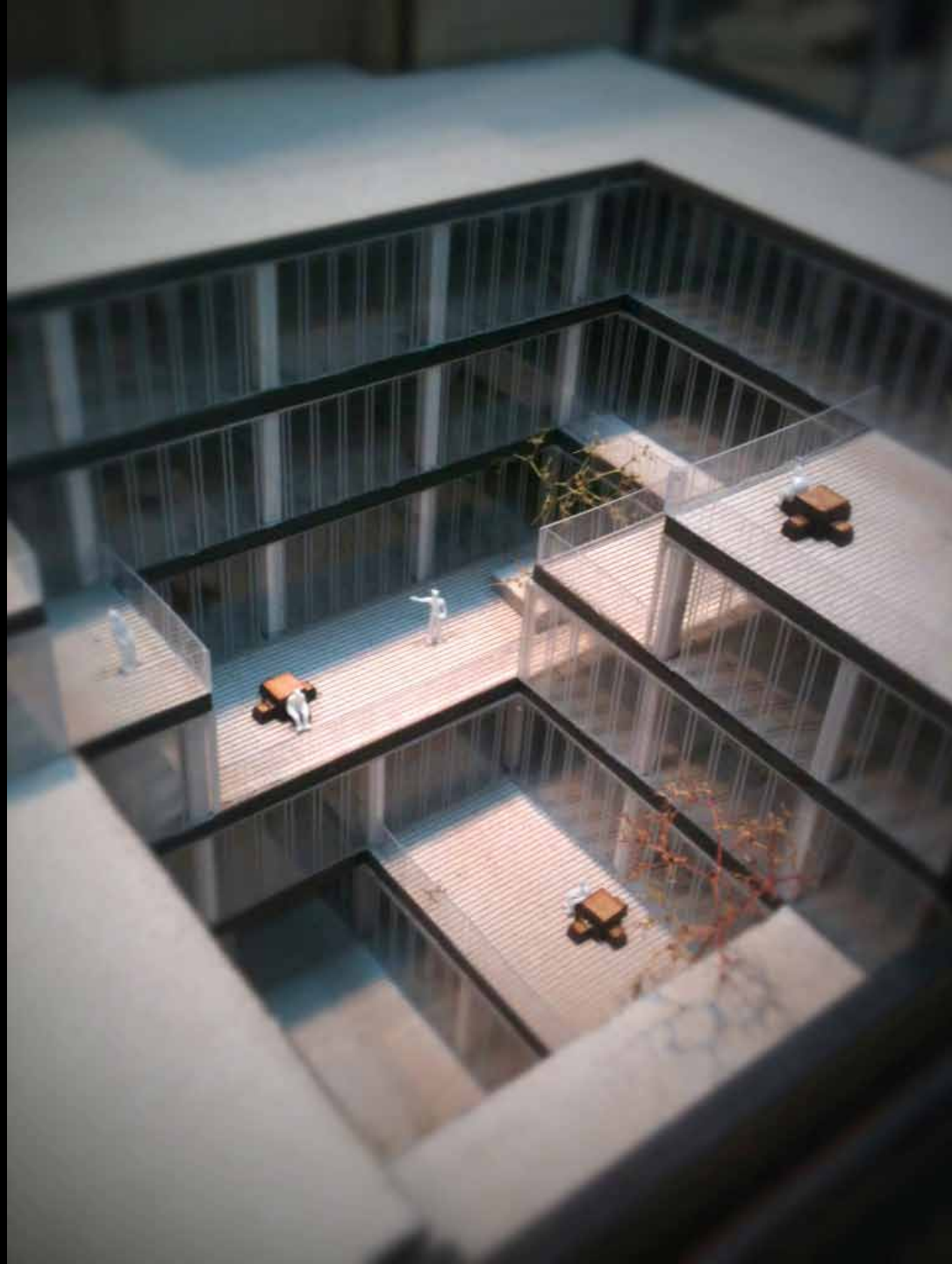

Design

7th Level

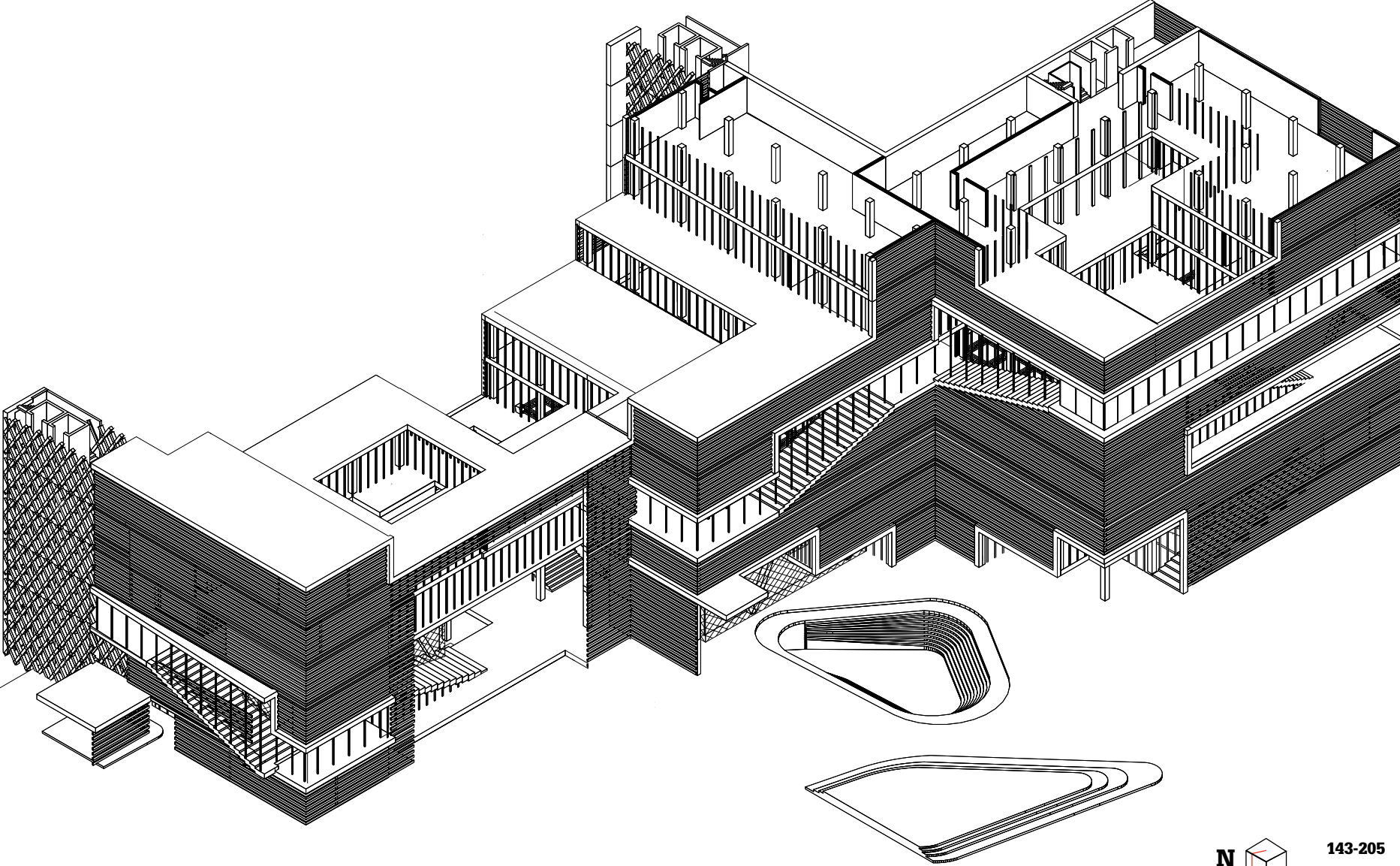

Design

7th Level

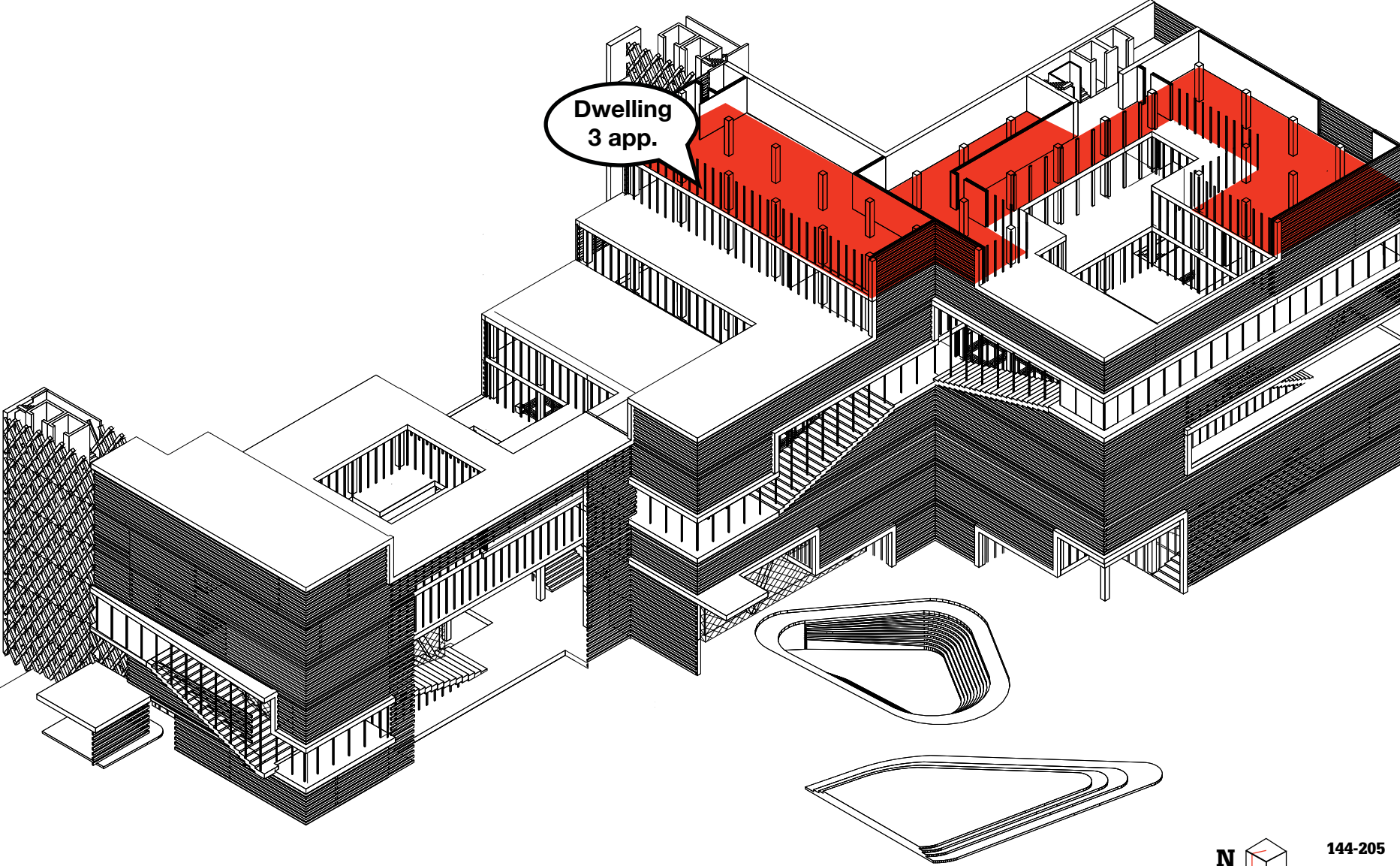

Design

7th Level

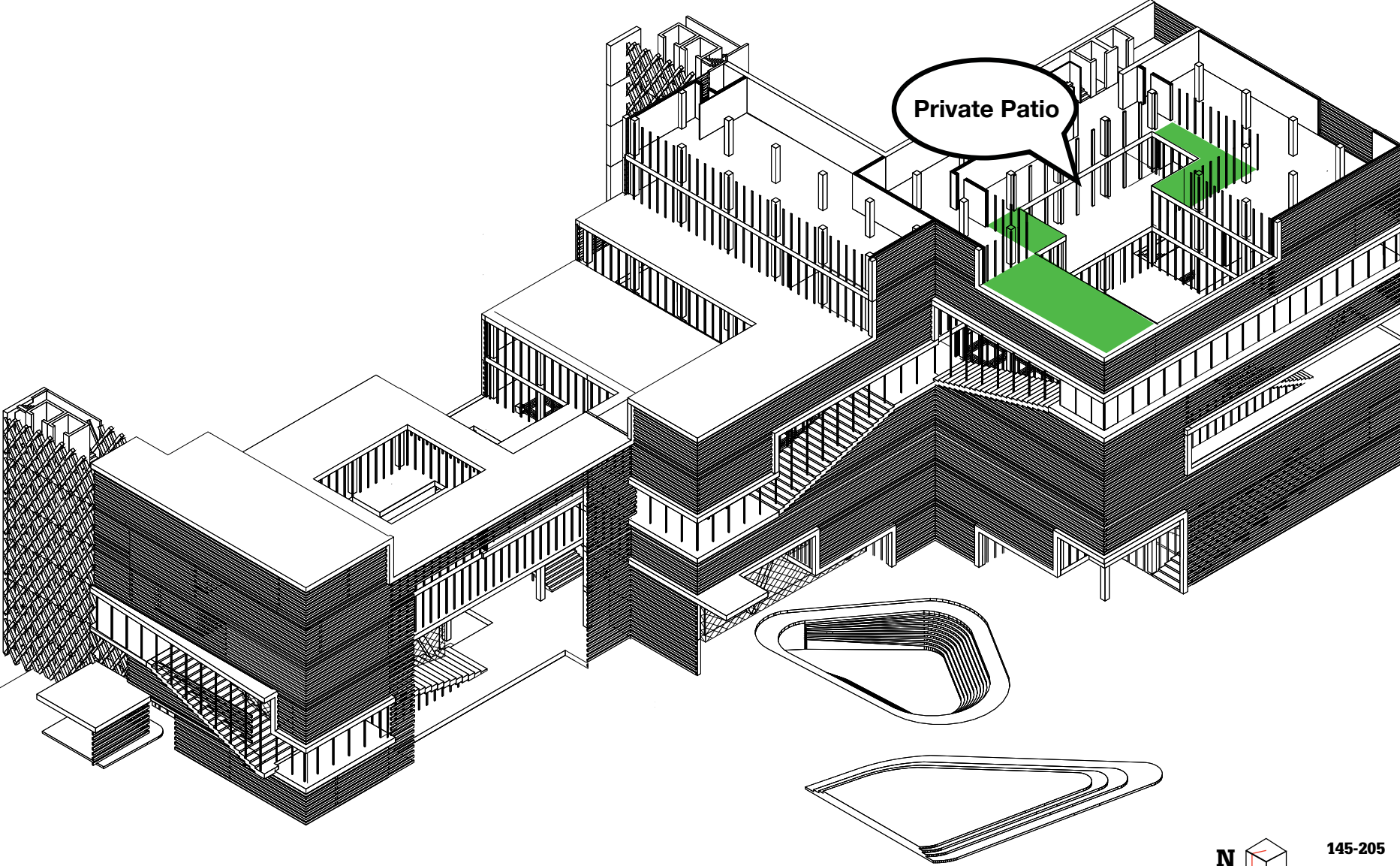

Private Patio



Design

8th Level

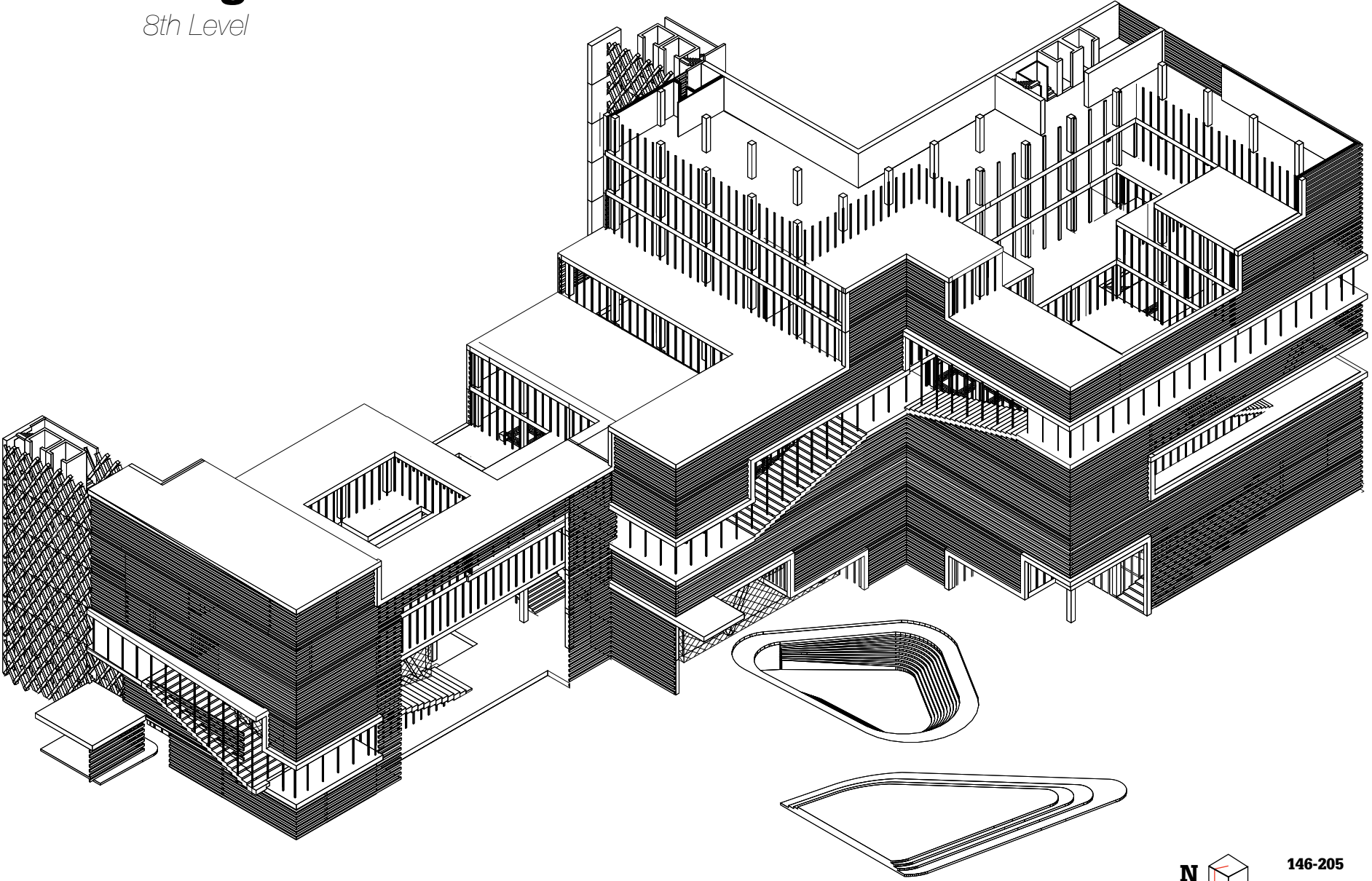

Design

8th Level

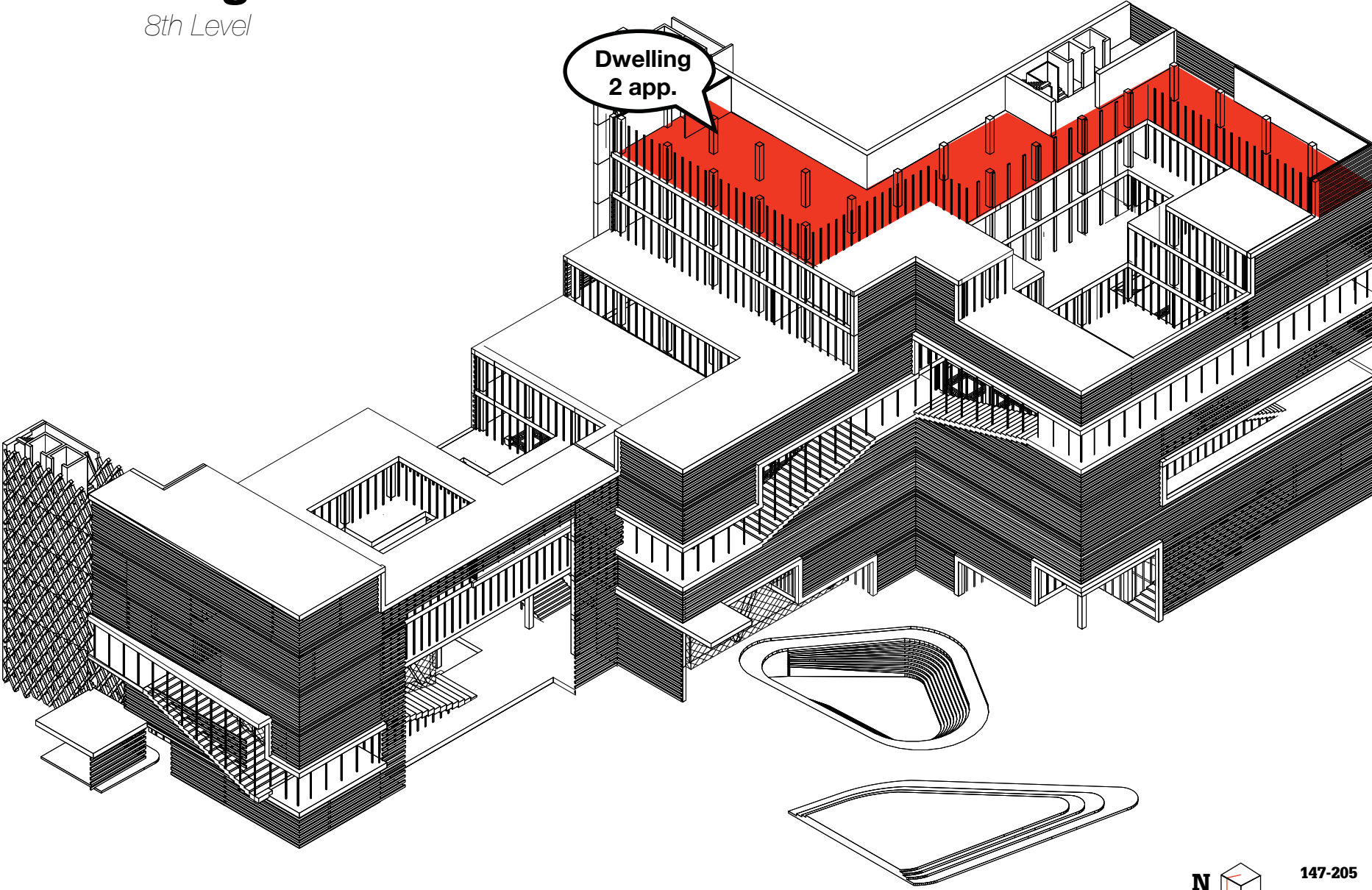

Design

8th Level

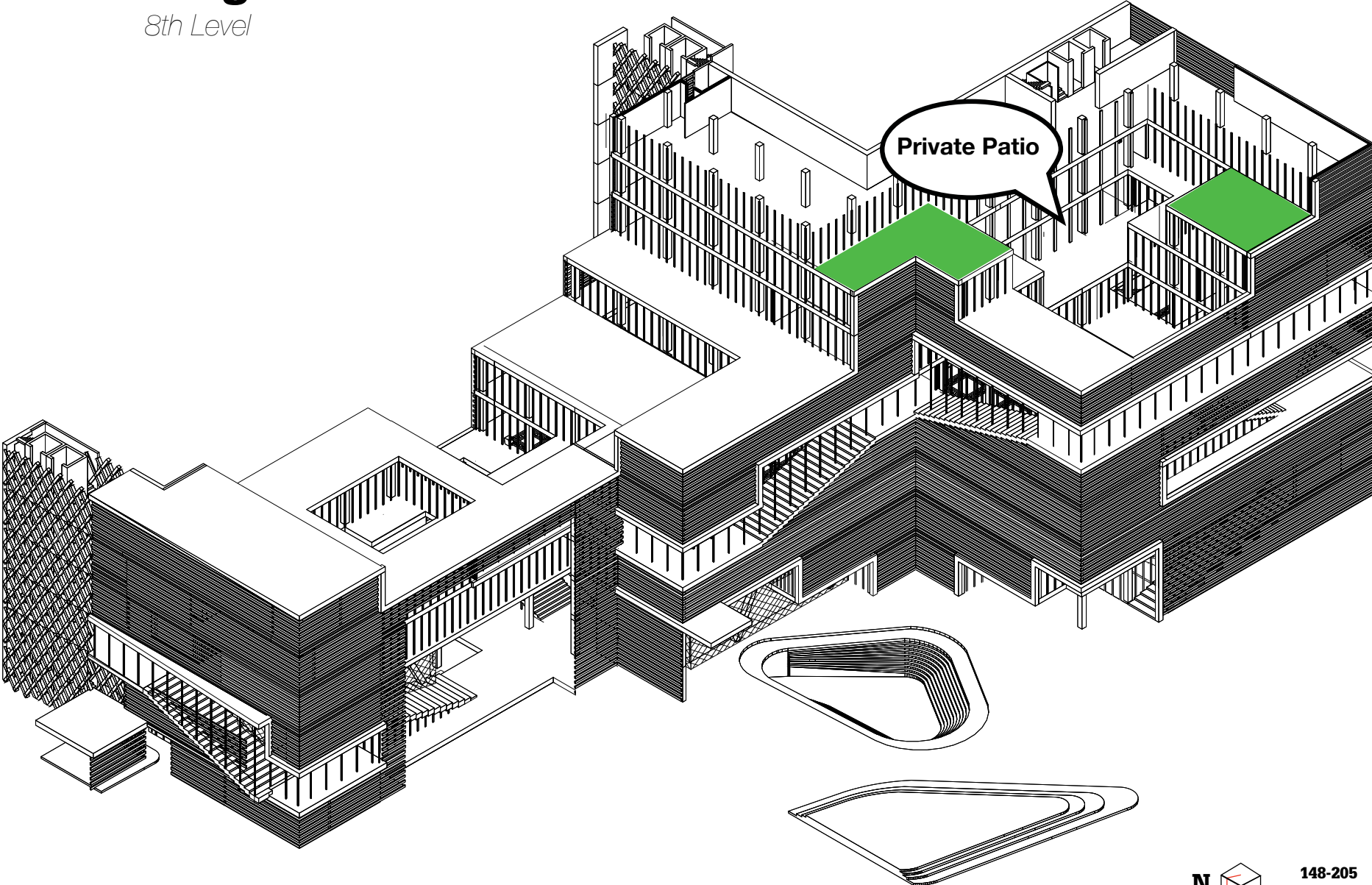

Design

Total

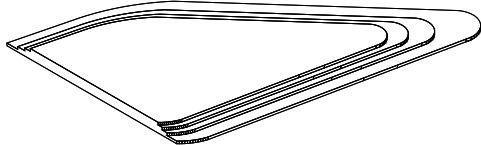
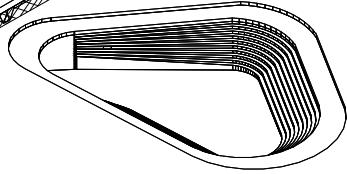
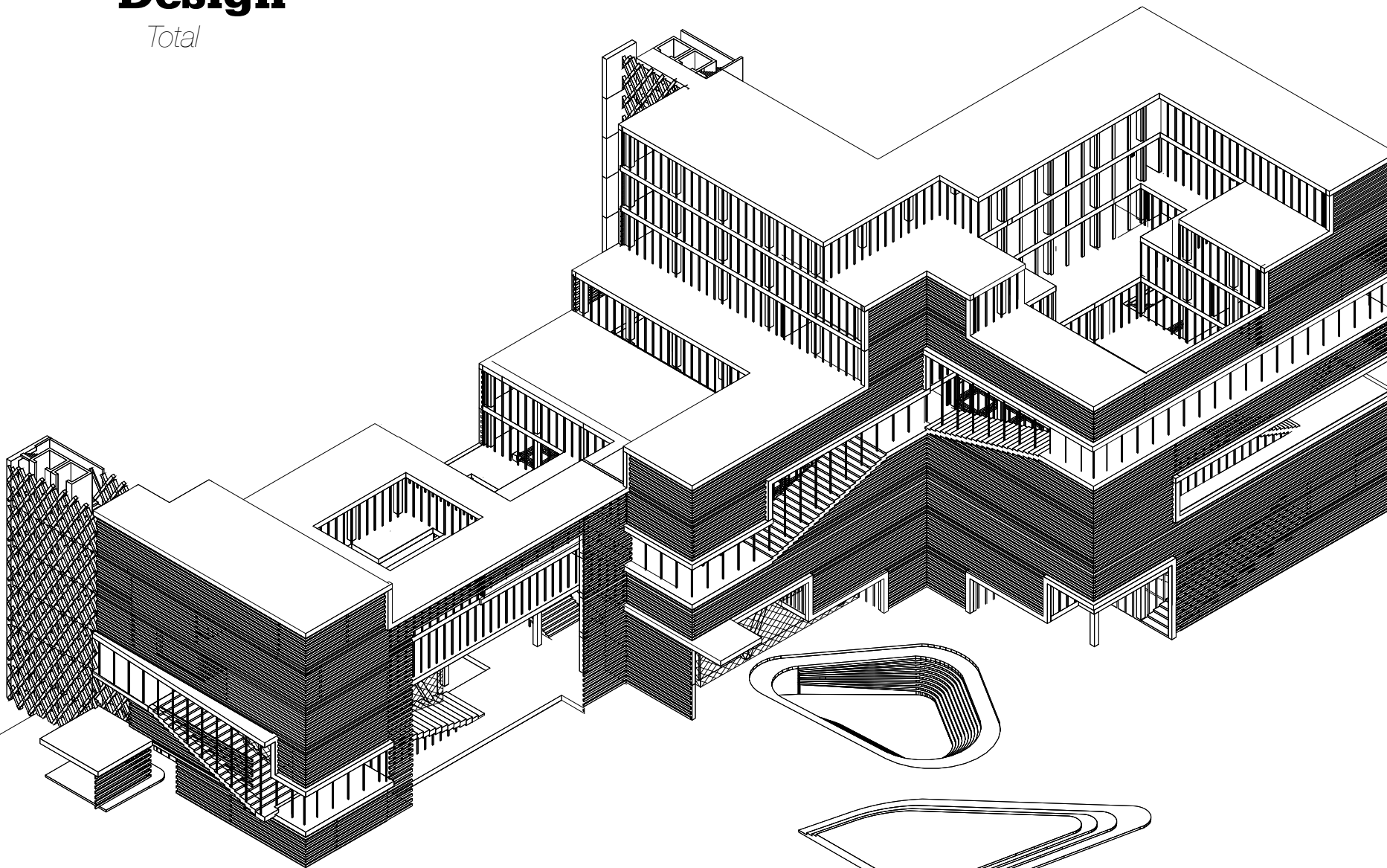



Materialisation

Materialisation

Concepts



Centercore

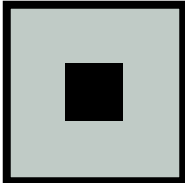

Skin

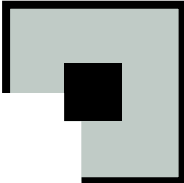

Cut-outs

Materialisation

References



Chu Hai College Campus, China, OMA, Model Proposal 2009



Beaux Arts Museum expansion, Quebec, OMA, Winning competition 2010



Wyly Theatre, Dallas, REX/OMA, 2002



Fünf Höfe, München, Herzog&deMeuron, 2003

Materialisation

Referencers



Materialisation

Referencers

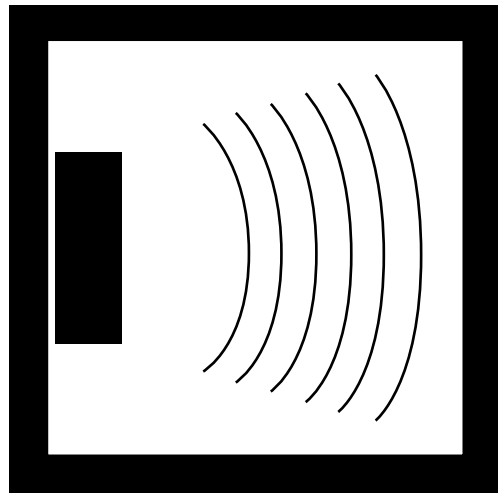

Materialisation

Referencers

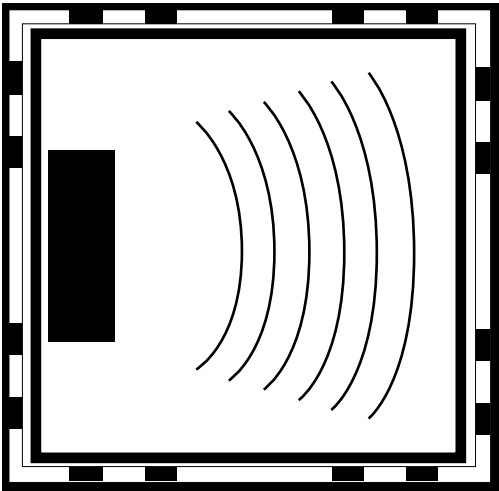

Materialisation

Referencers

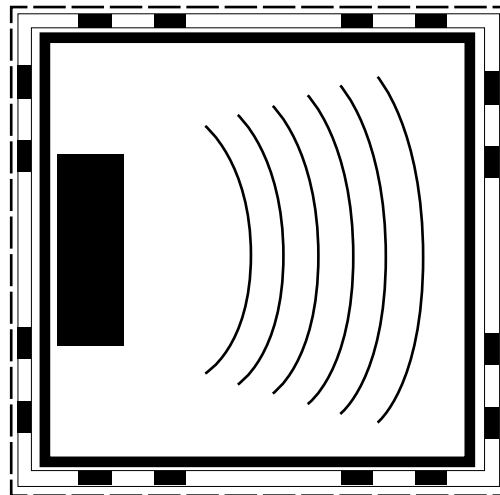

Materialisation

Referencers

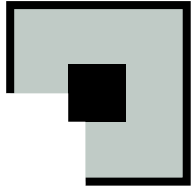

Instead of a simple stacking of floors, floors are connected with each other by a continues 'public street' which -not then a rather 2D plan or facade, allows public life to create spontaneous social interactions that normally happen on the street.

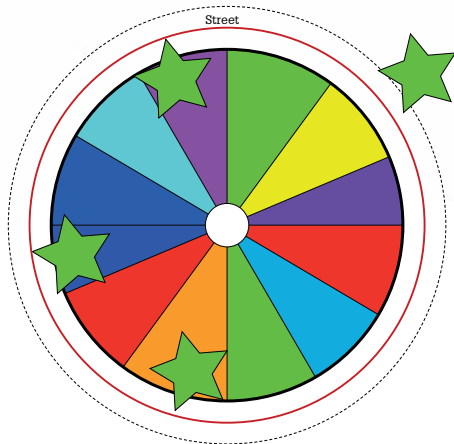

Materialisation

Referencers

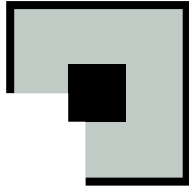

Metal Foundation, Baragano, Spain, 2011



Dutch Embassy, OMA, Berlin, 2001



Chelsea Market, Meatpacking District, New York



Passage Verdeau, Paris, 1847

Materialisation

Referencers

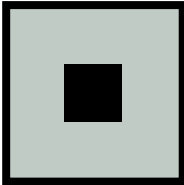

Millstein hall, University of Cornell, OMA, Built 2011



Chu Hai College Campus, China, Model Proposal 2009



Wyly Theatre, Dallas, REX/OMA, 2002



CLC & MSFL Towers, REX, China, Proposal 2011

Materialisation

Referencers

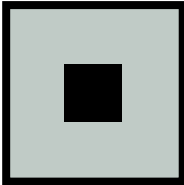

Materialisation

Referencers

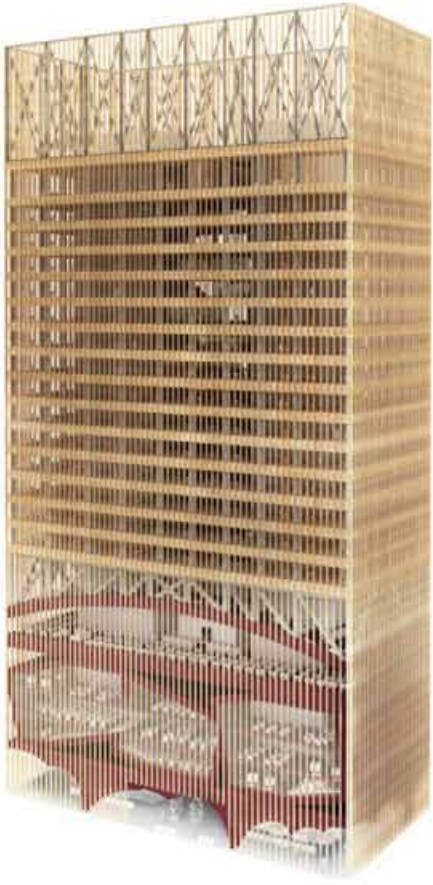
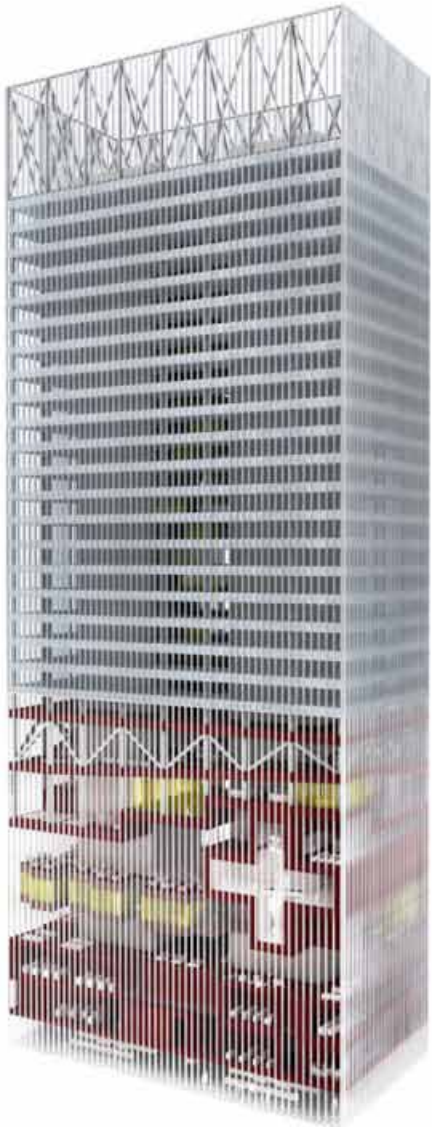
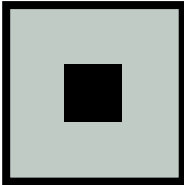

CLC & MSFL Towers, REX, China, Proposal 2011

Materialisation

Study

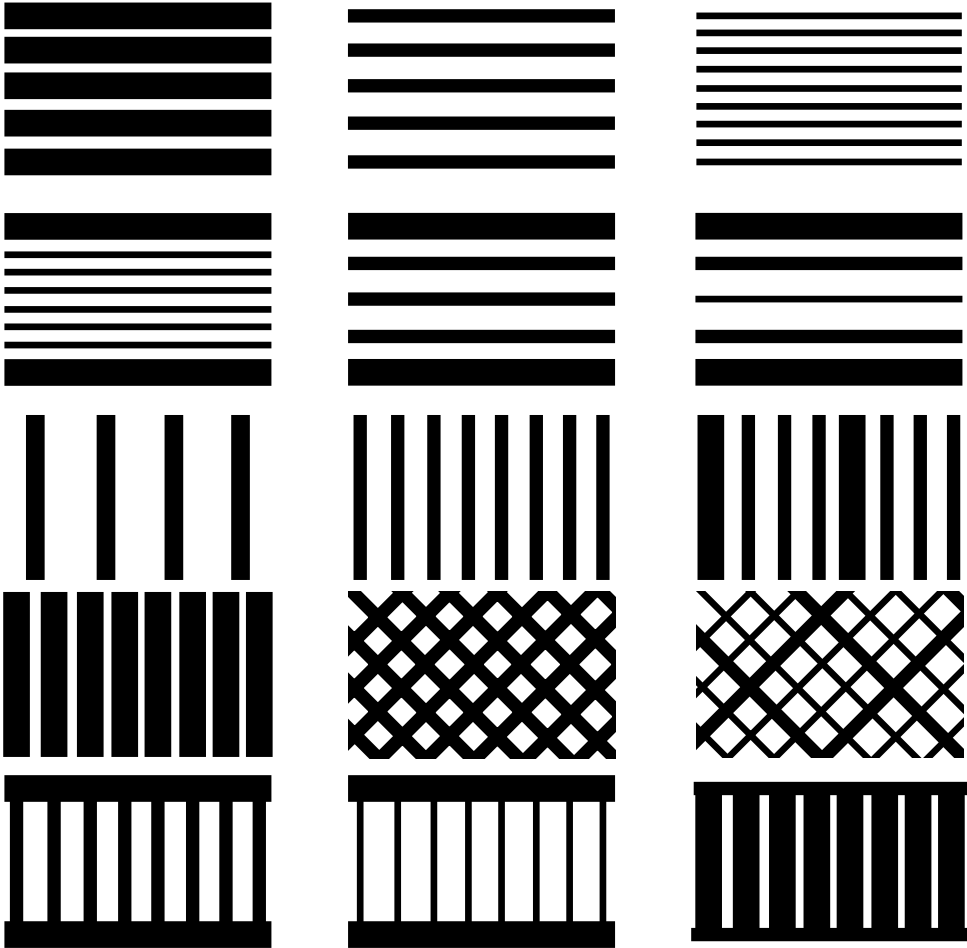

Materialisation

Study

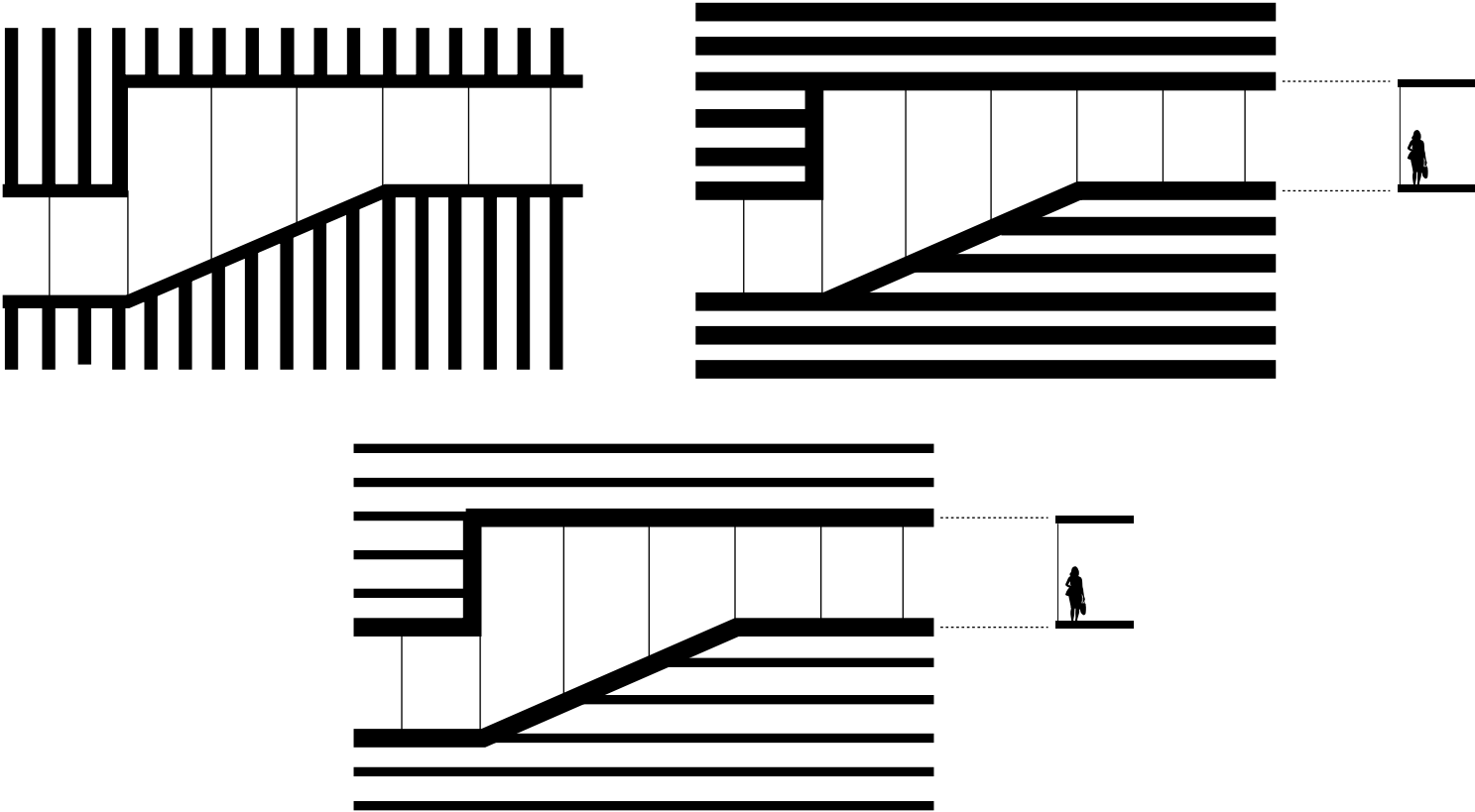

Materialisation

Study

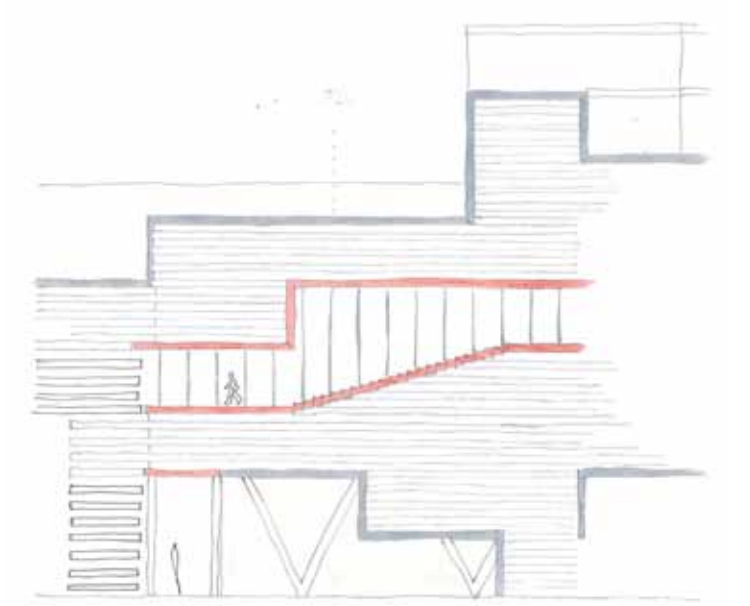
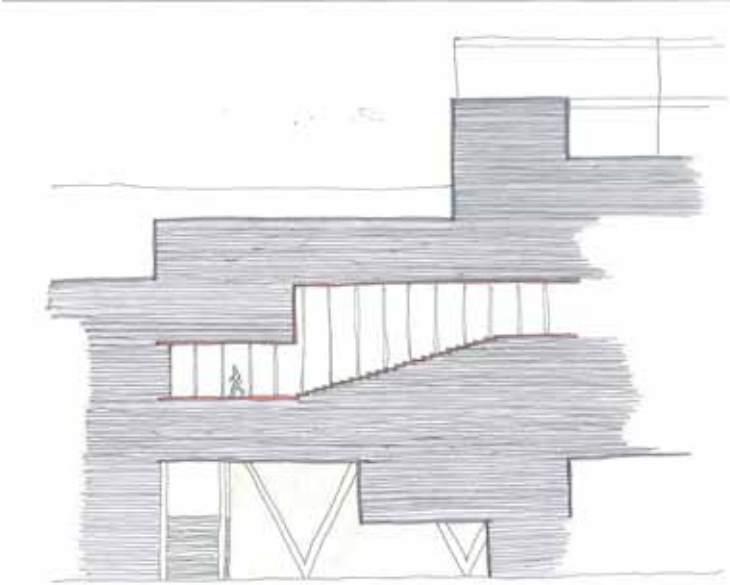
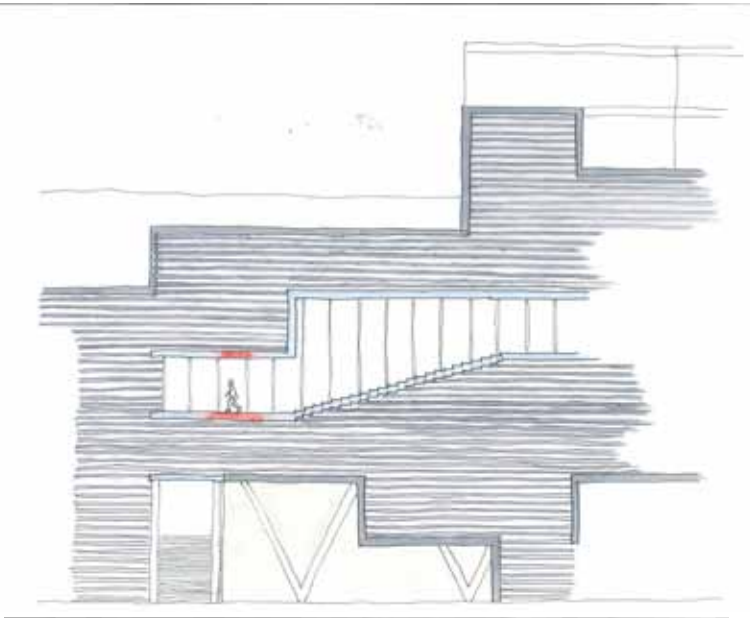
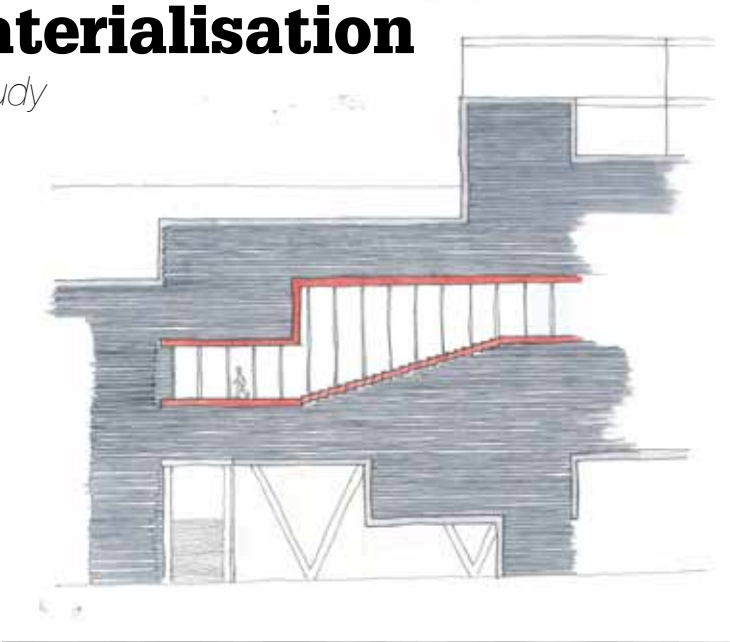

Materialisation

Study

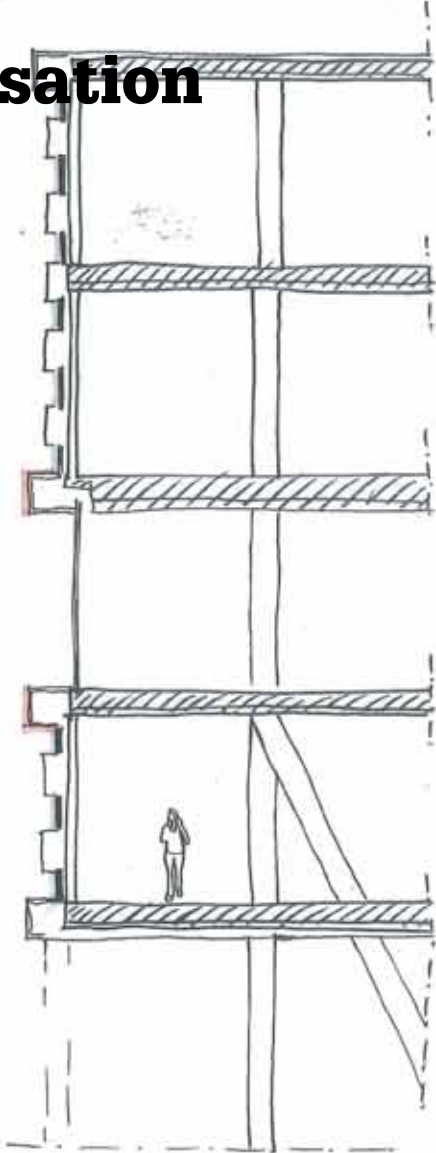

Lines 500 mm on frame

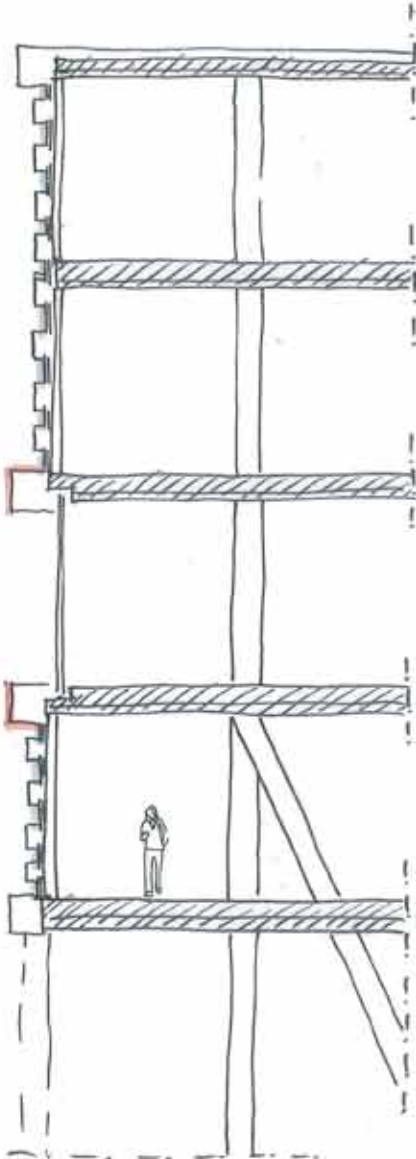

Lines dense on frame
250 mm

Materialisation

Study

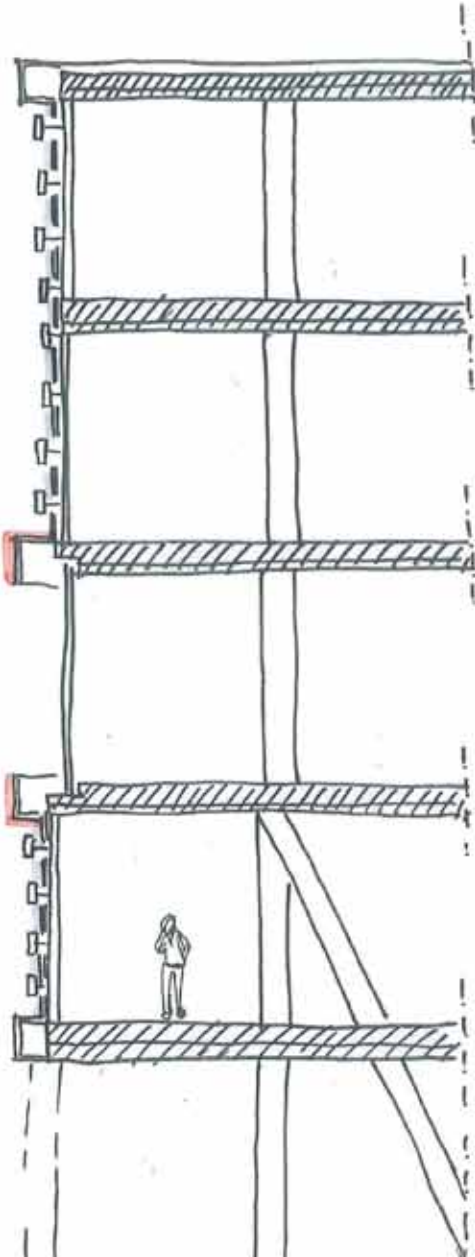
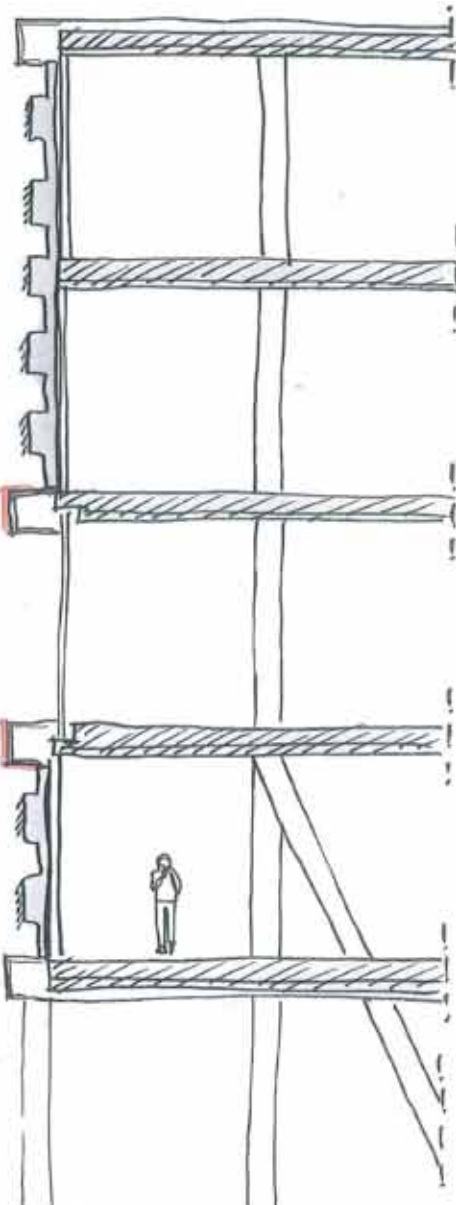
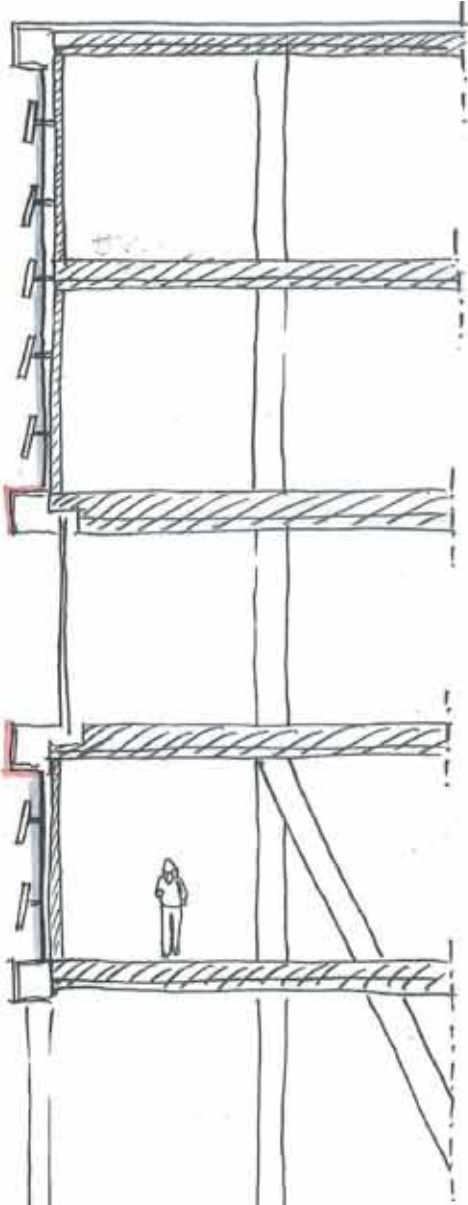

Materialisation

Lijnbaan Stage

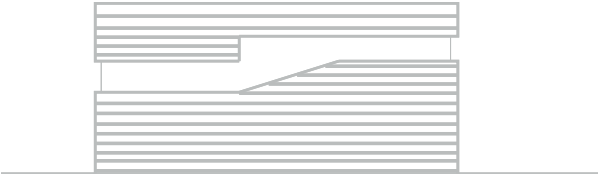
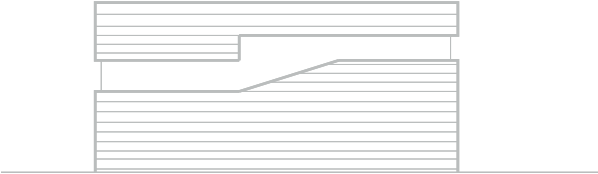
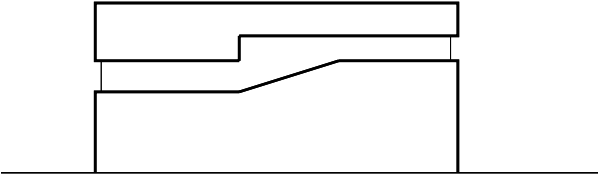

Oh..! That looks like a street inside a building!



Materialisation

Square stage

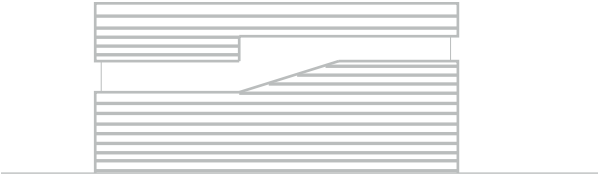
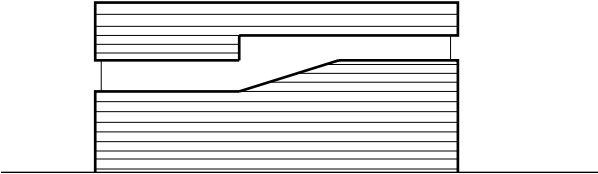
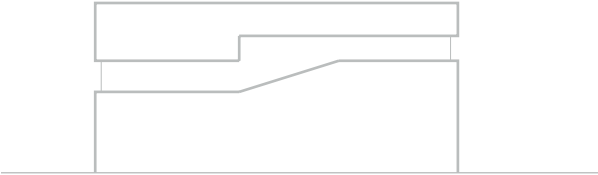

Aha! the horizontal lines define the building, public spaces are cut out

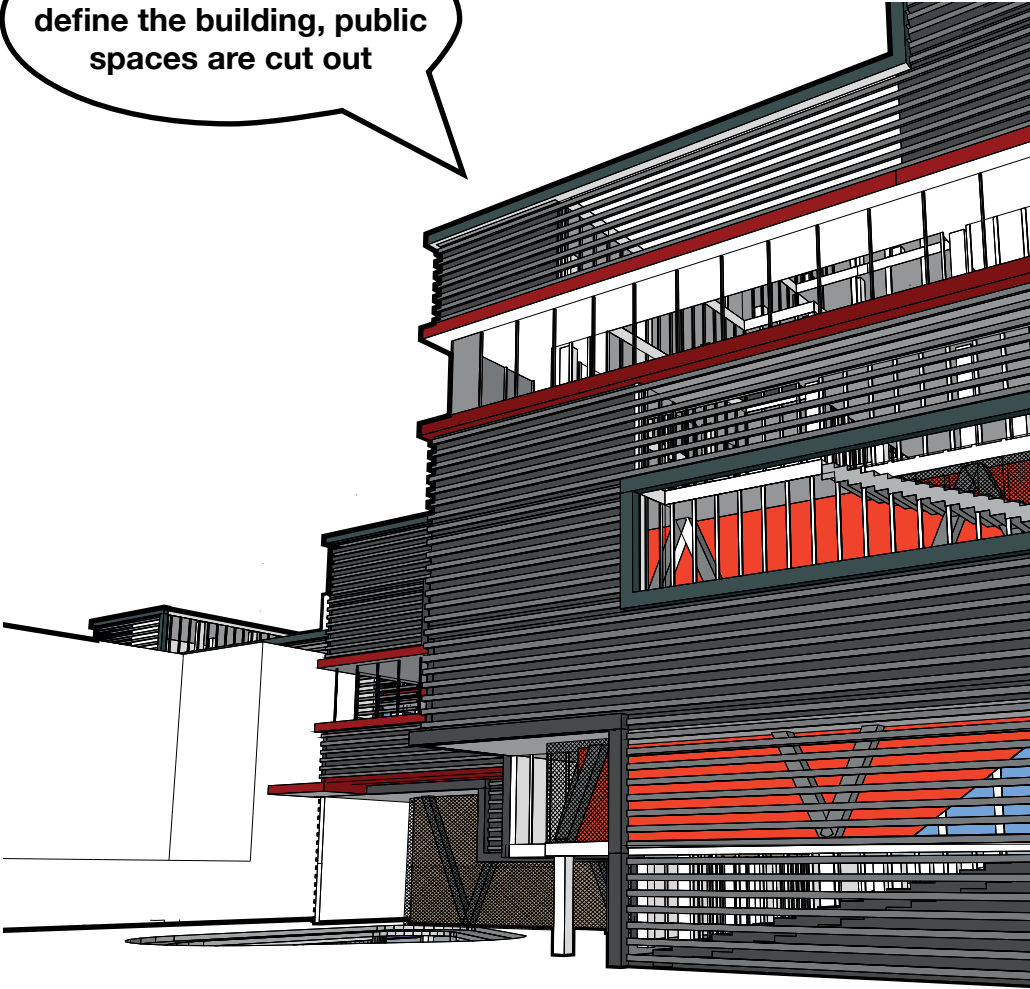

Materialisation

Entry stage

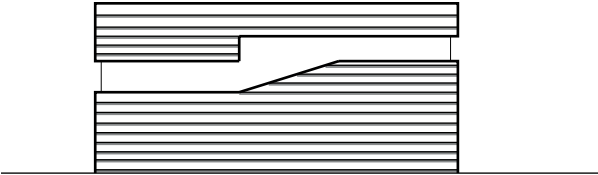
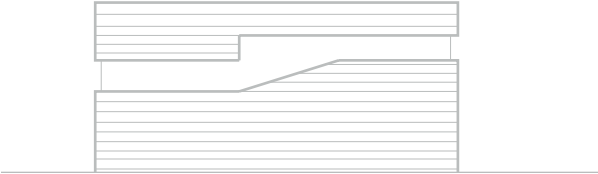
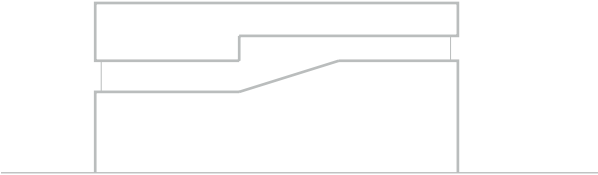

The steel lines wraps around a concrete block, with cultural boxes as center.







Sustainability

Sustainability

Conceptstatement

Sustainability is not a question of how much we are able to sacrifice
in order to afford to become sustainable?

Let people want to be sustainable, so that they can be part of the
'green' environment

Sustainability should bring pleasure and fun.
Rather than a moral sacrifice or political challenge.

Sustainability

Functional requirements

- MAIN** **Dance (performance 200p)**
Theatre (600 p)
Film (auditorium 350 p)
- SECOND** **Sports (fitness, Squash, Massage)**
Danceschool (Ballet, streetdance)
Offices with Conferencerooms
Restaurant
- THIRD** **Social facilities, discoussionrooms, teaching**
Small bars (Coffee/functional bar)
Dwelling

Predominance

Theatre, Dance and Film

- Mechanical Ventilation
- Heating trough **ventilation**
- Humidity

Restaurant and bars

- Mechanical ventilation
- controlable ventilation
- Concrete core activation for heating and cooling

Dwelling, Offices, Social functions and school

- Mechanical ventilation
- controlable ventilation
- Central Heating

Sports

- Mechanical Ventilation
- Heating trough **ventilation**

Sustainability

Summer

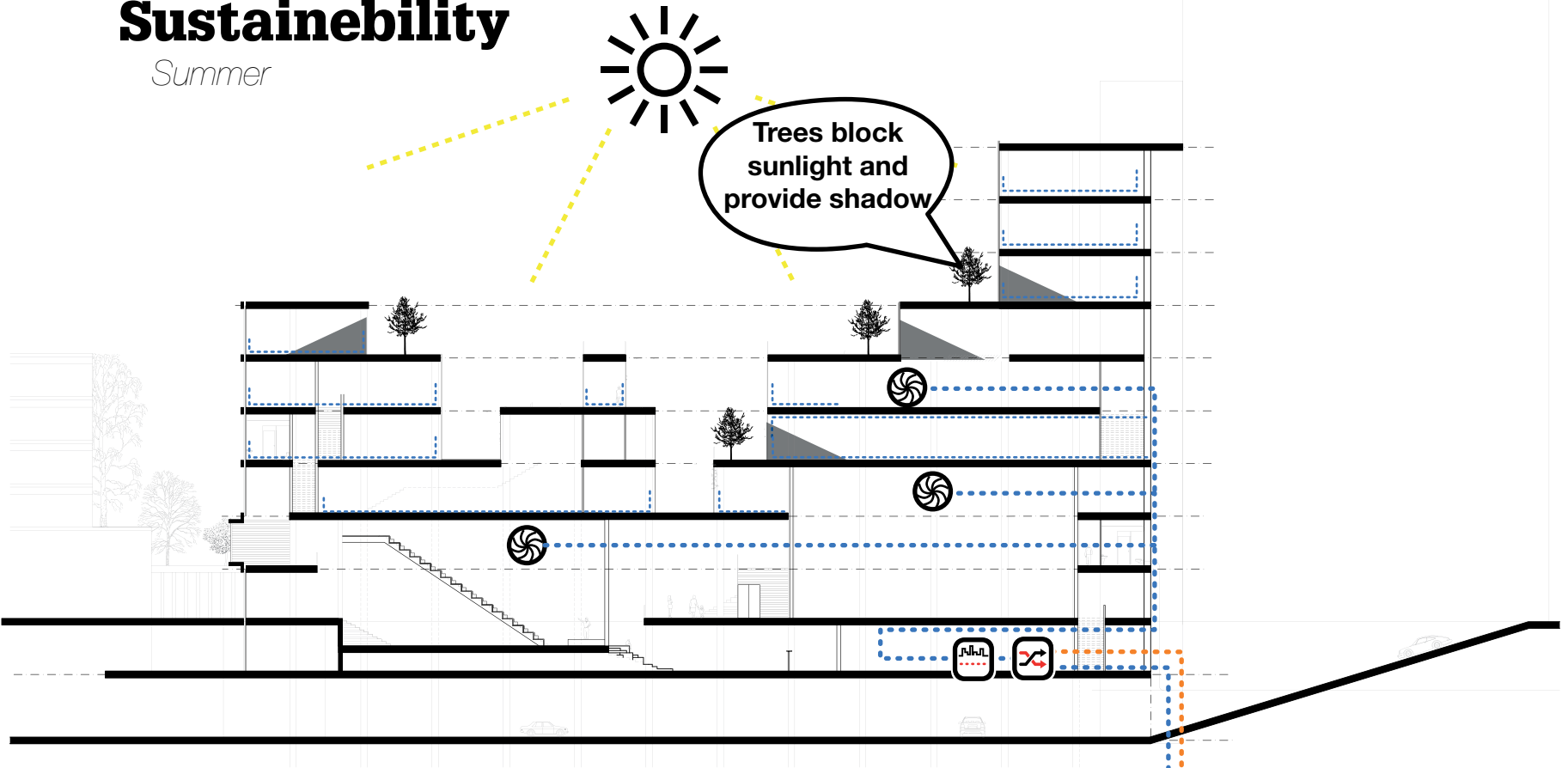

Trees block sunlight and provide shadow

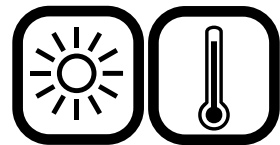

Summer Day

12° 8°



Sustainability

Summer

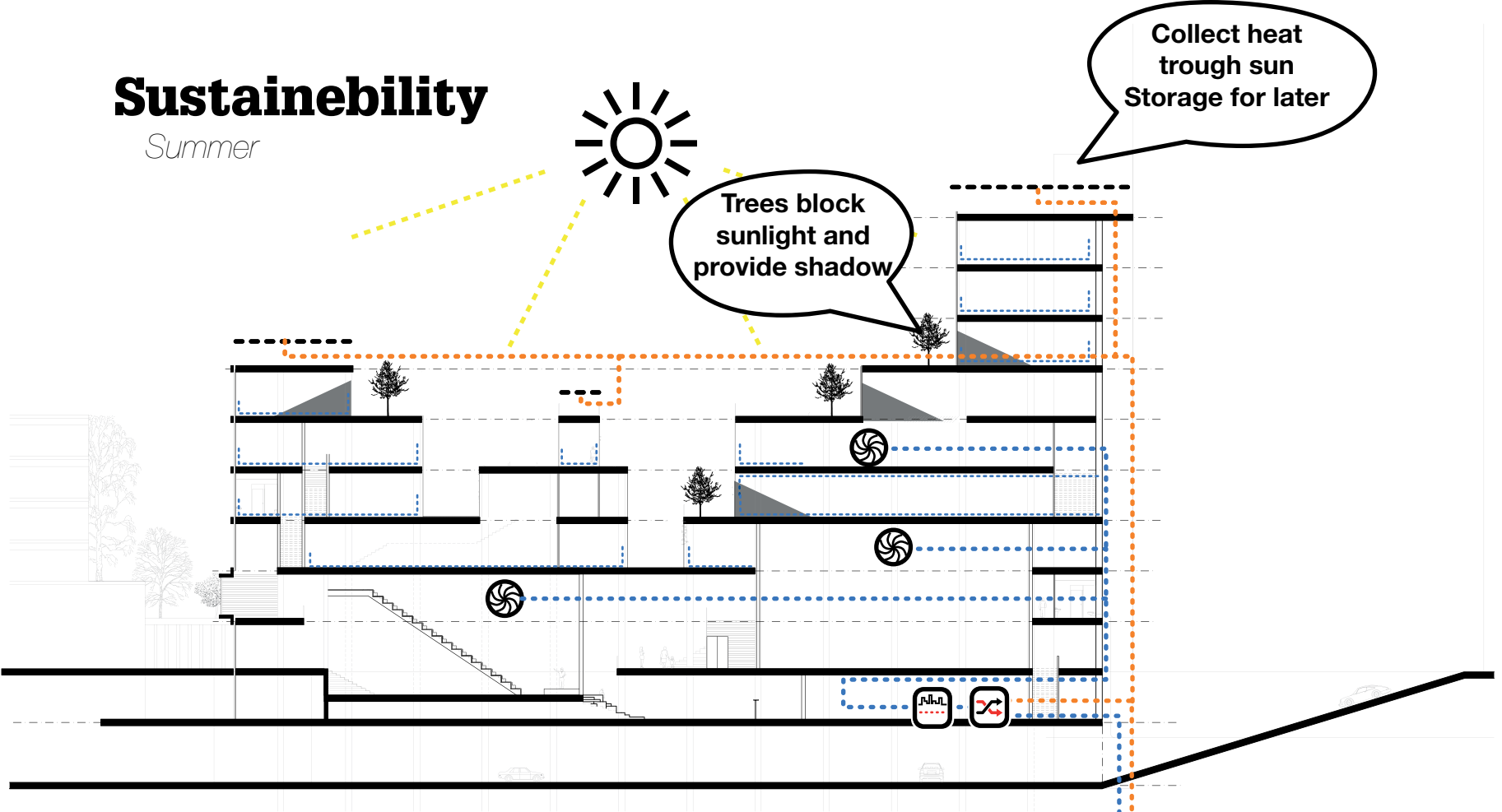

Trees block sunlight and provide shadow

Collect heat trough sun
Storage for later

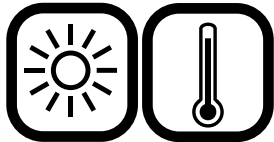

Summer Day

12° 8°



Sustainability

Summer

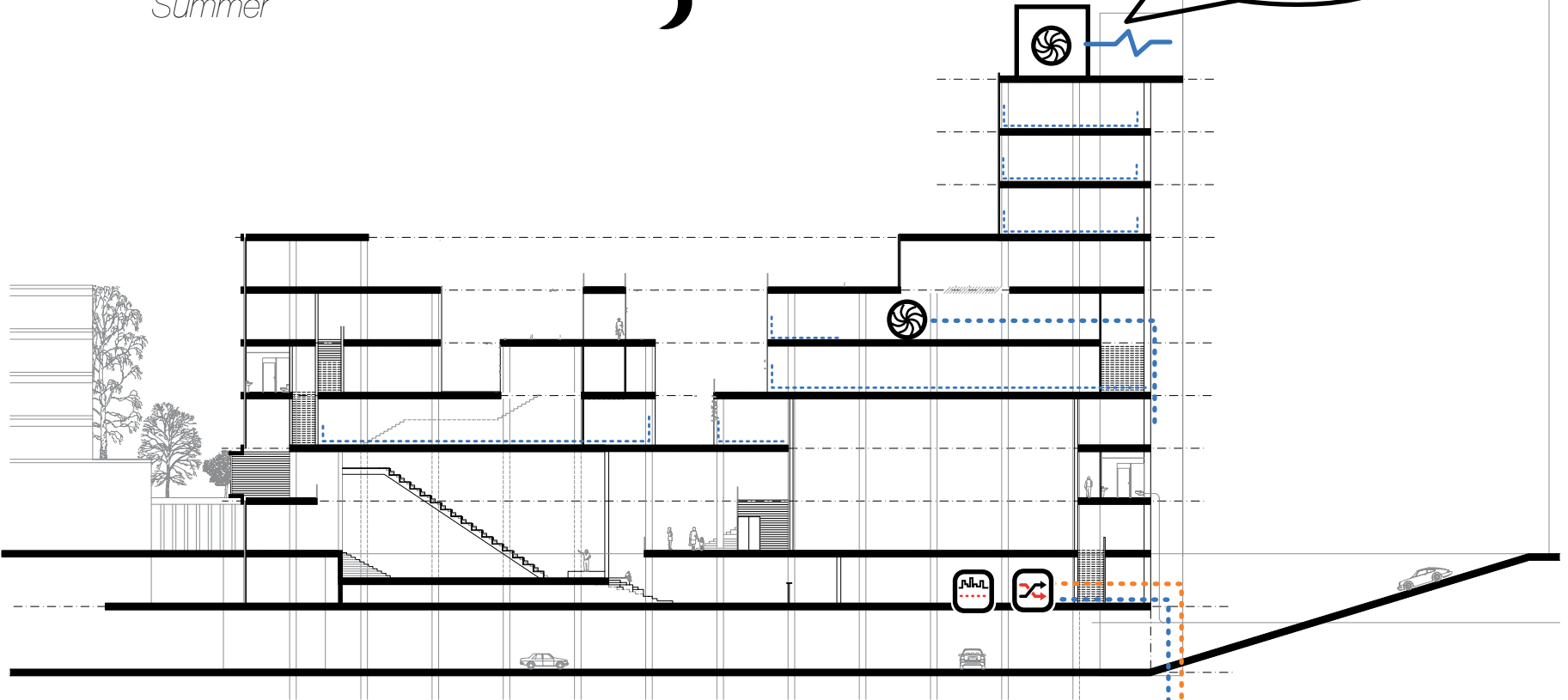

Transmission trough wind. Storage for later

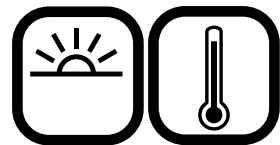

Summer Night

12° 8°



Sustainability

Winter

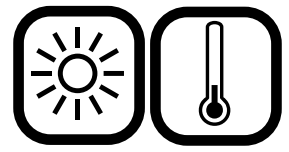
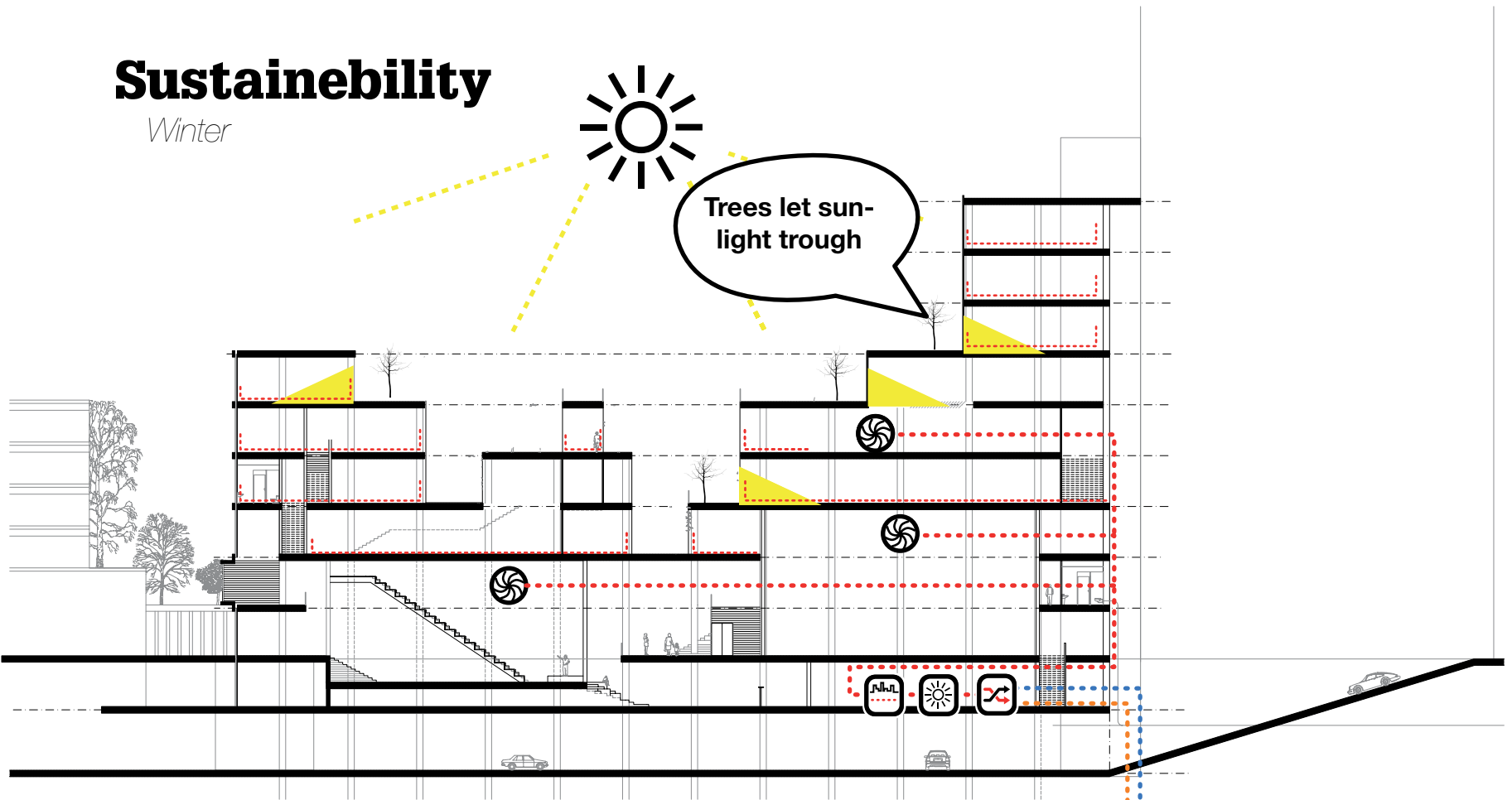

Winter Day

Sustainability

Winter

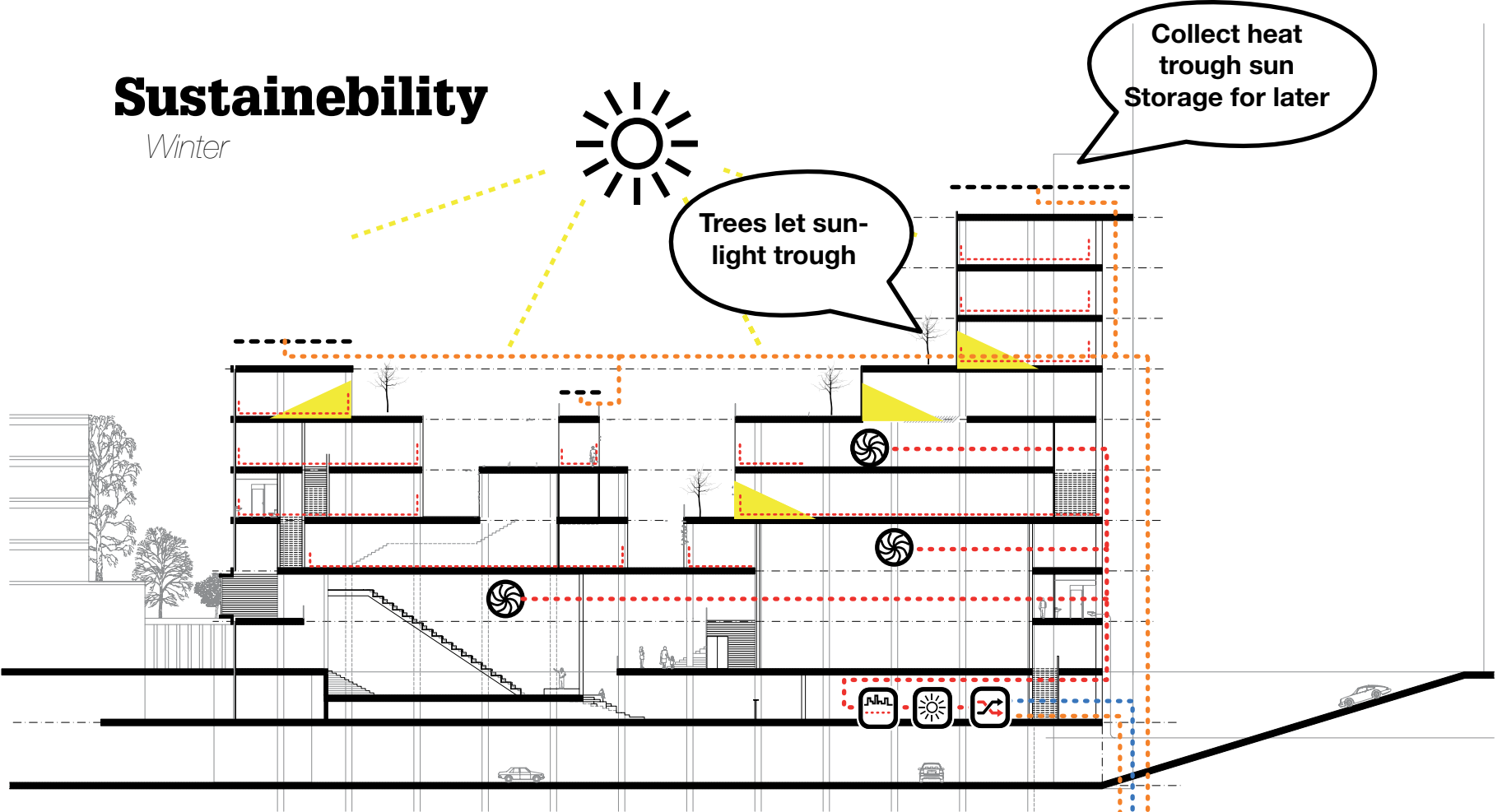

Trees let sunlight trough

Collect heat trough sun Storage for later

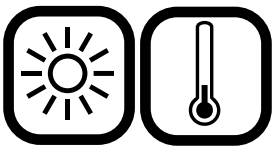

Winter Day

12° 8°

Sustainability

Winter

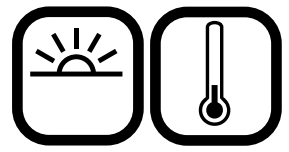
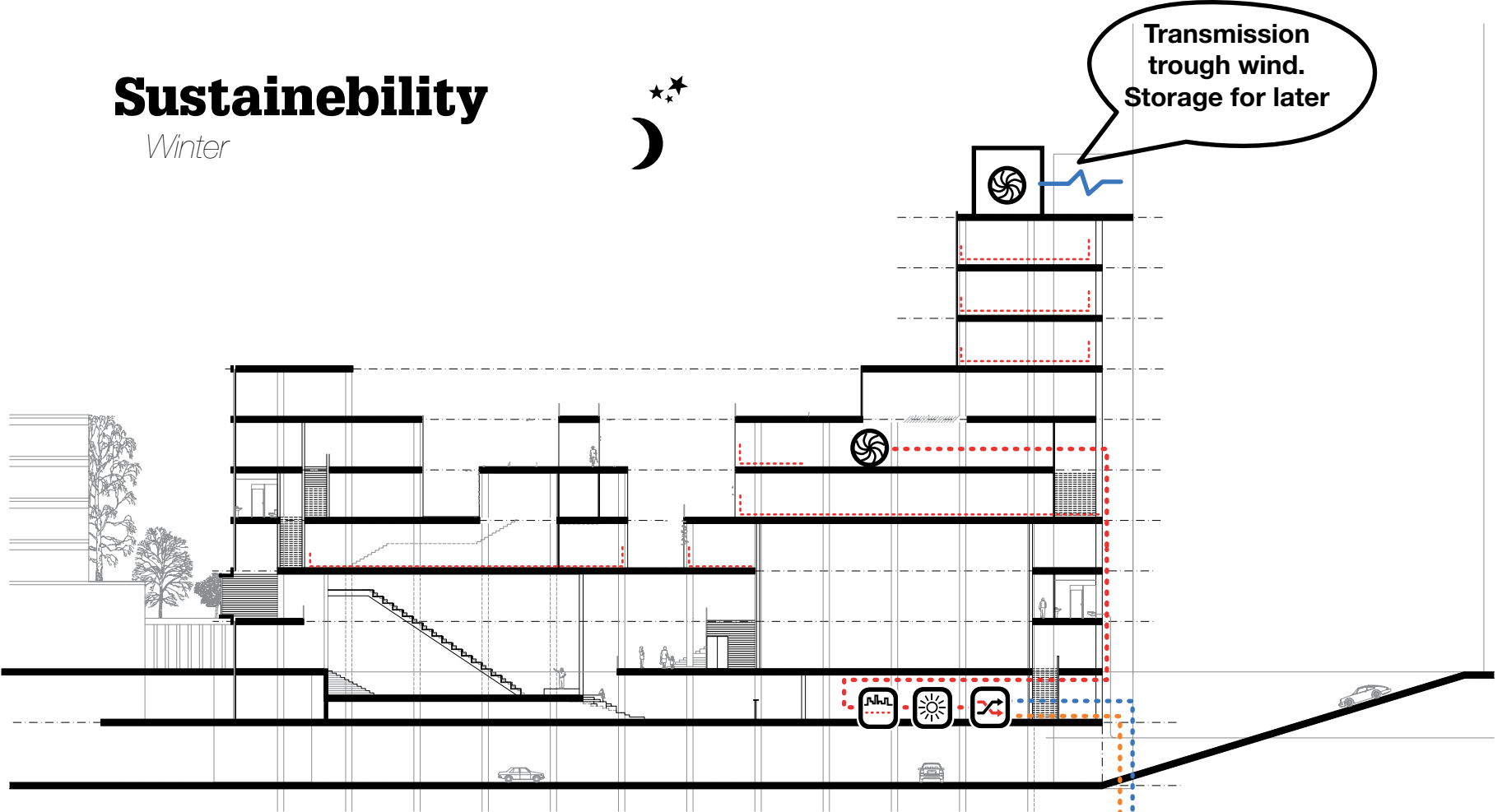

Winter Night

Sustainability

Ventilation

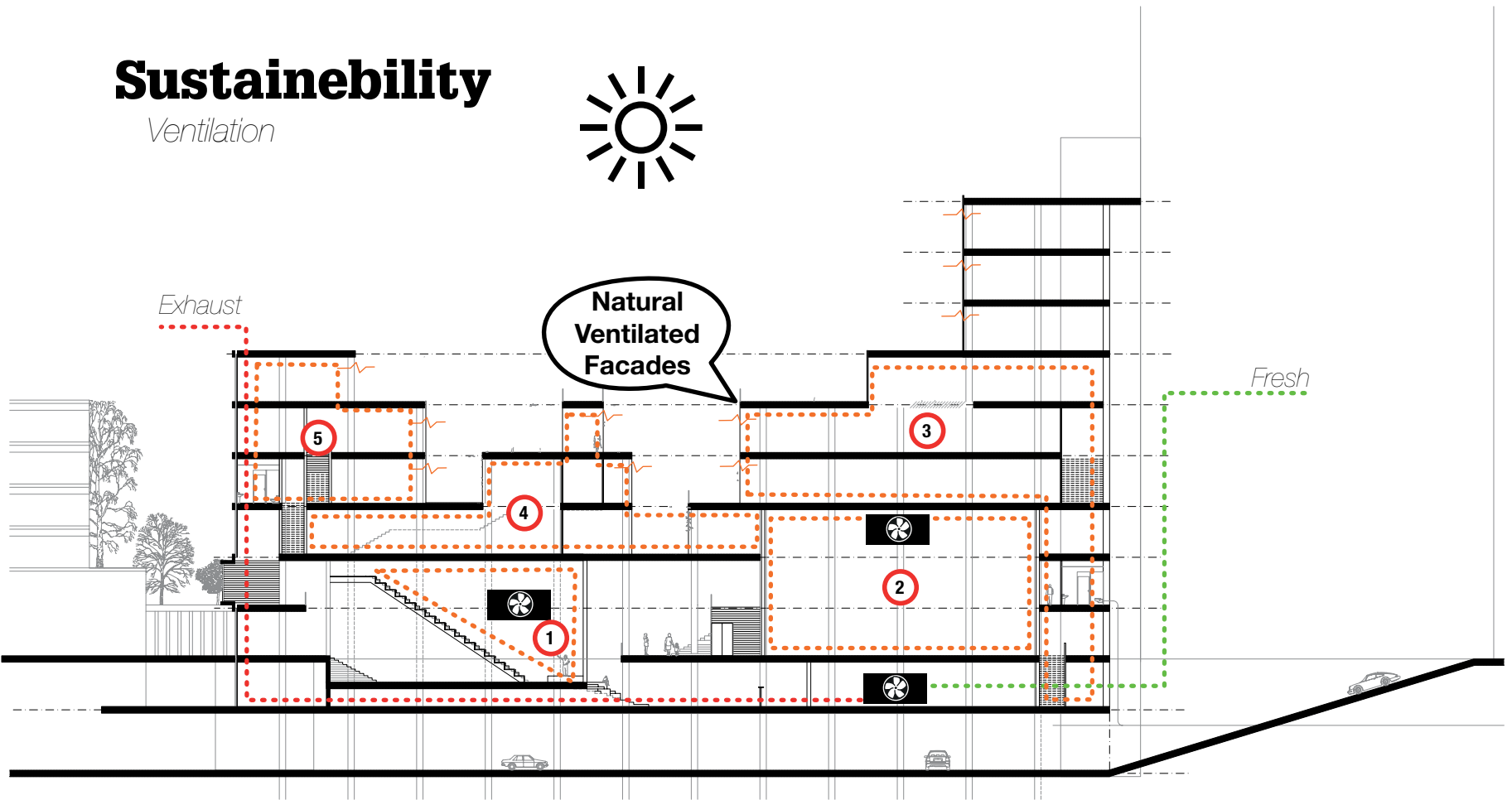
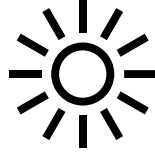

Exhaust

Natural Ventilated Facades

Fresh

5

4

1

2

3

Ventilation

North

PWD

Sustainability

Water re-use

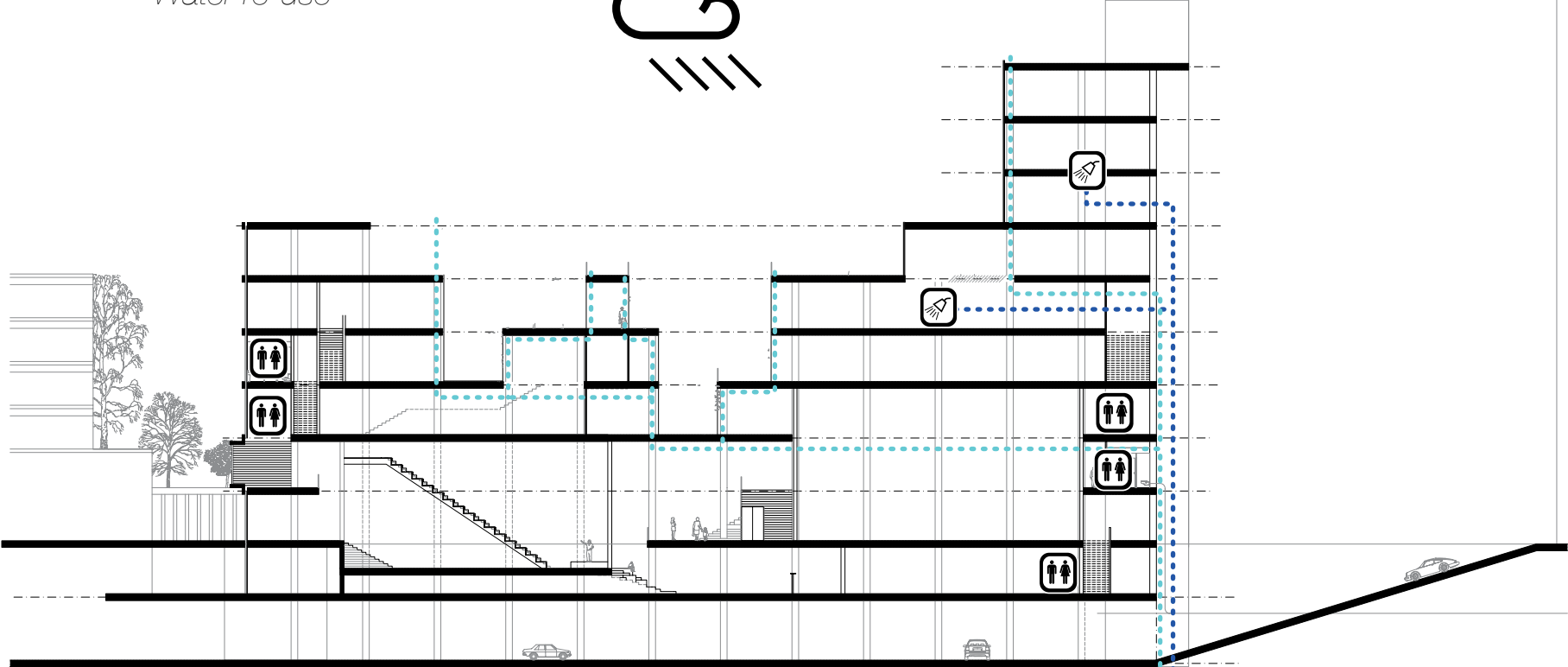

Water re-use

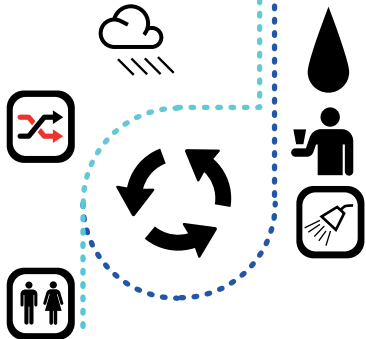

Sustainability

Energy Sufficiency

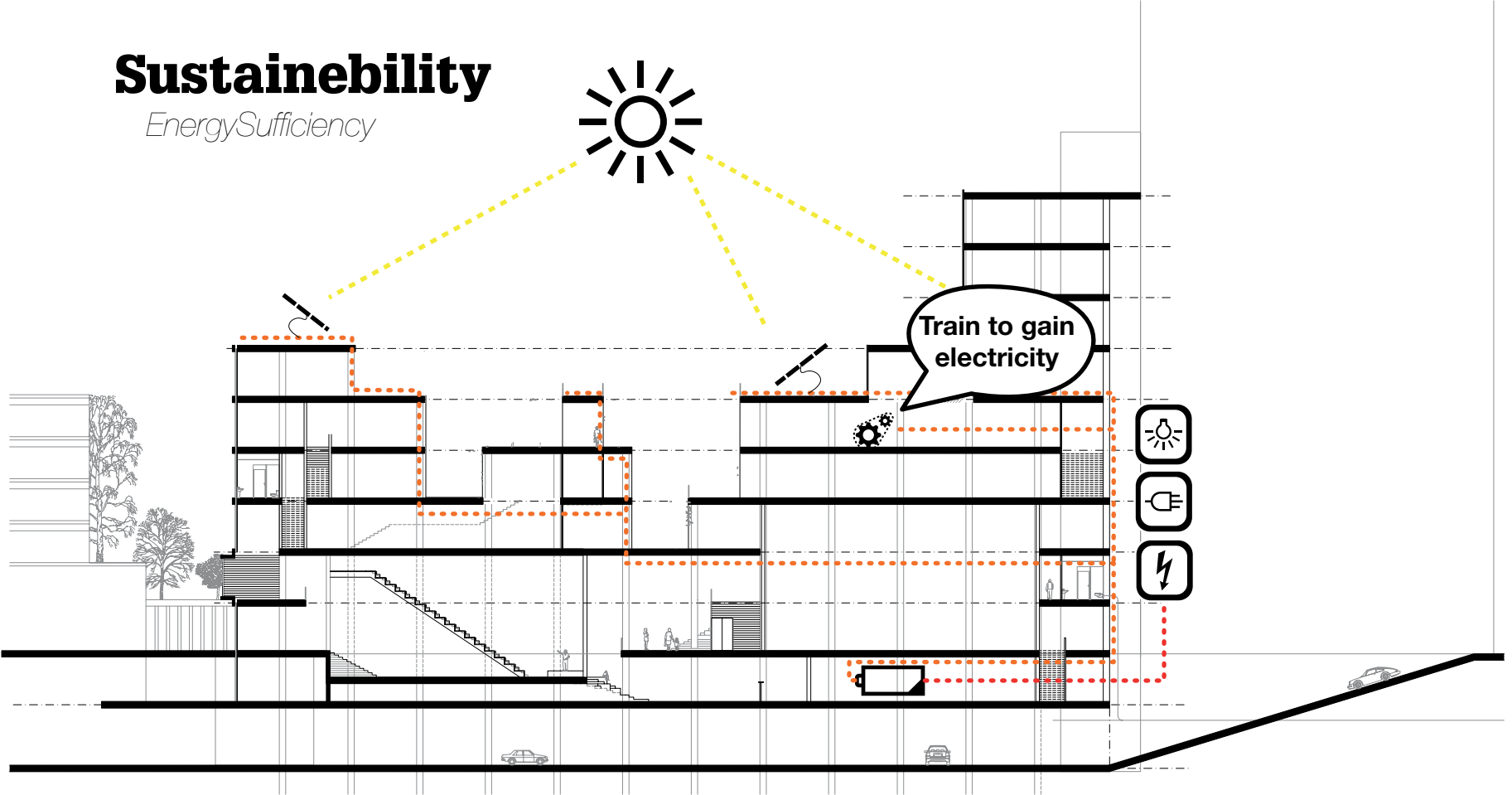
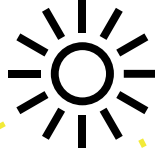

Train to gain electricity

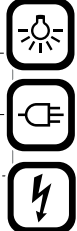

Energy sufficiency



Sustainability

References

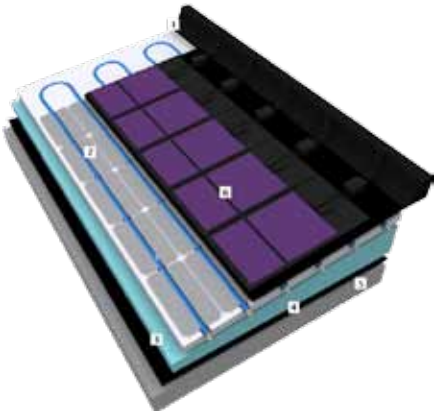

Sustainability

References

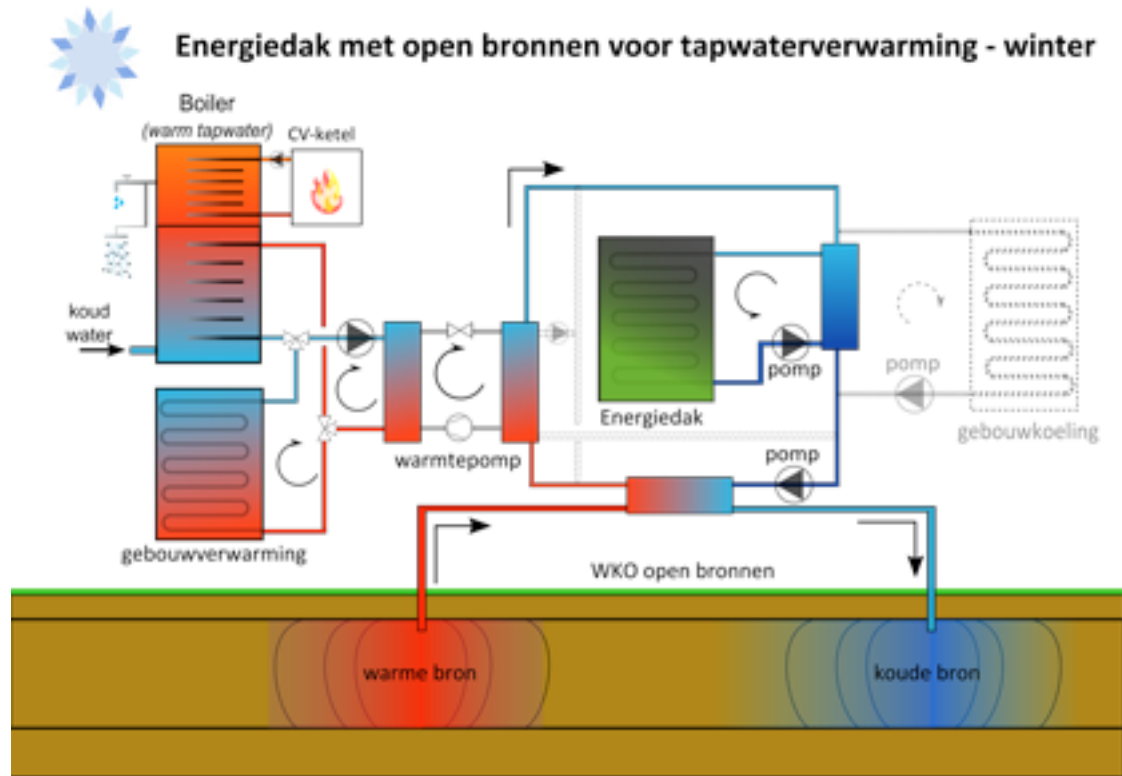

Construction

Construction

Principle

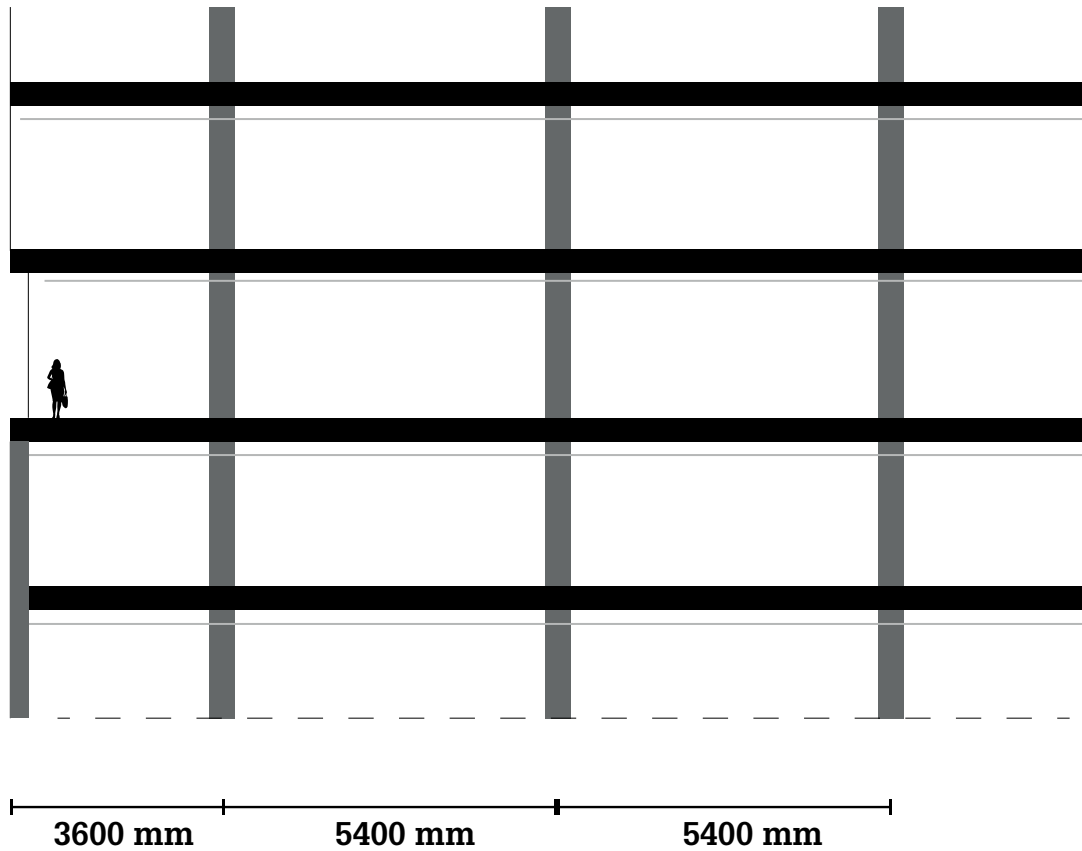

Construction

Principle

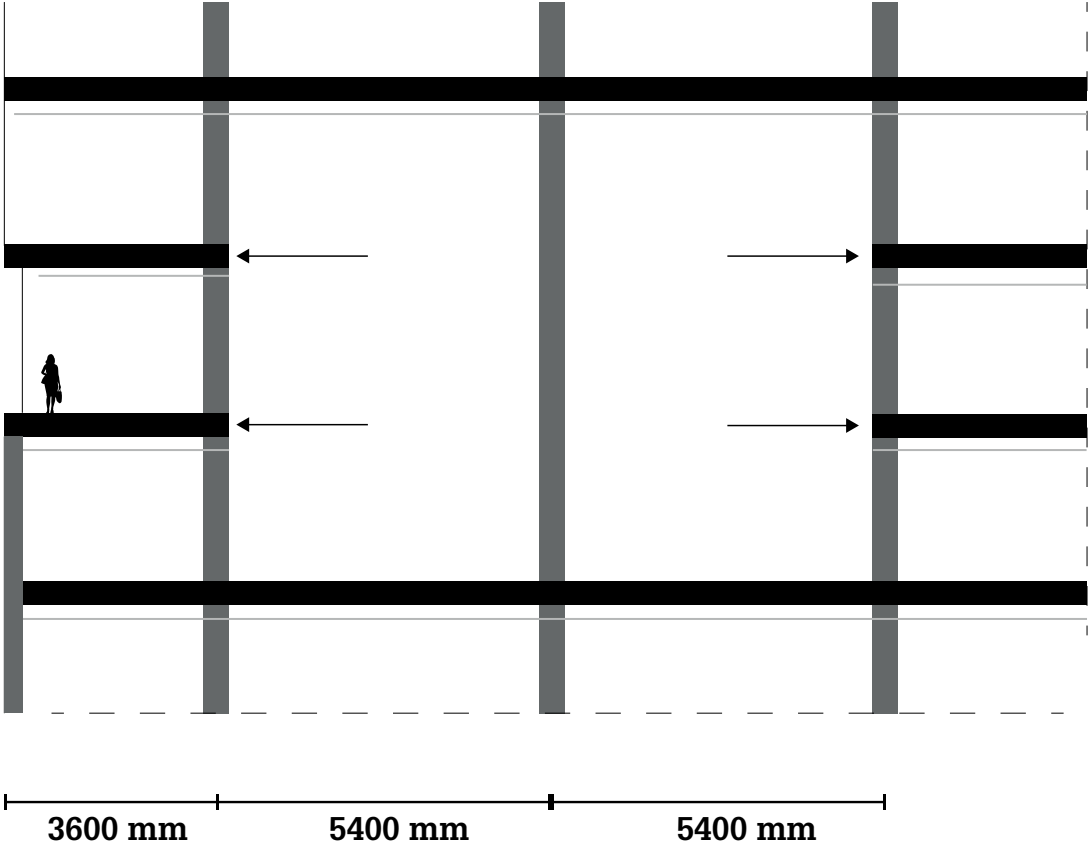

Construction

Principle

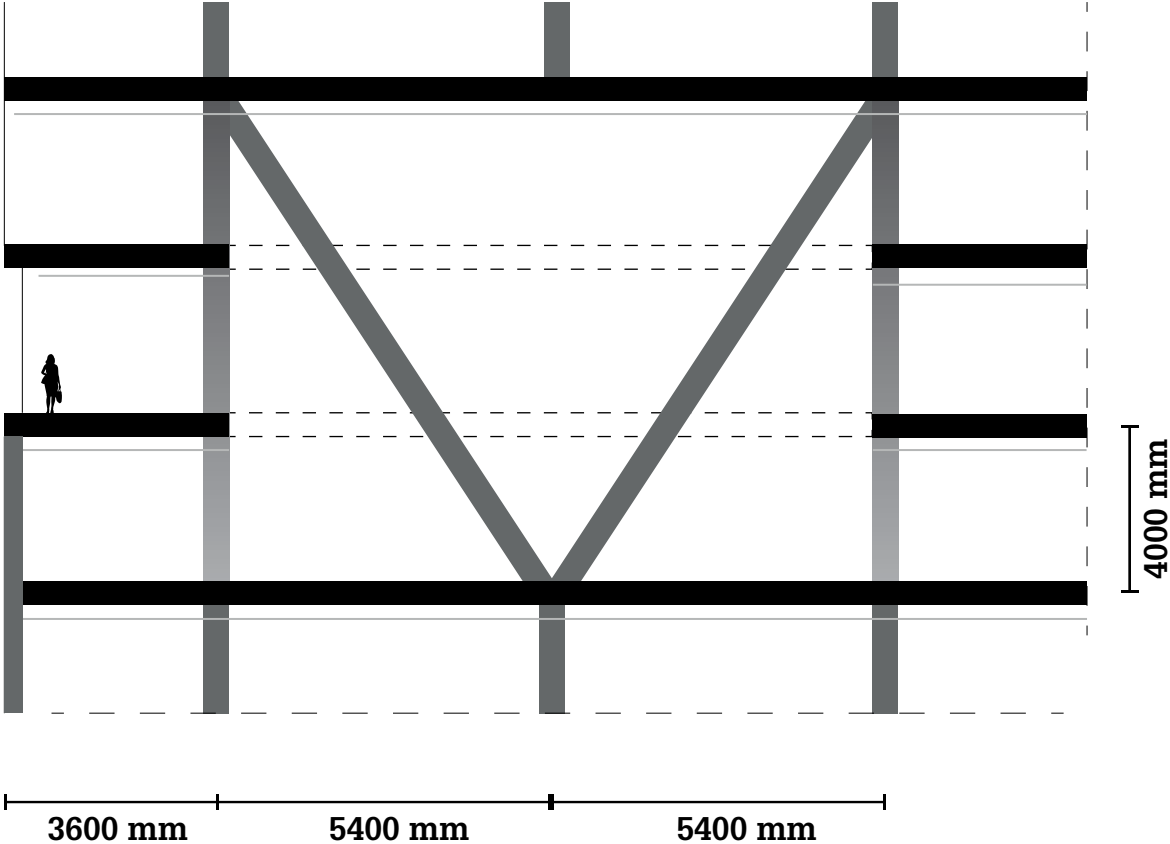

Construction

Principle

Construction provides consciousness of the space

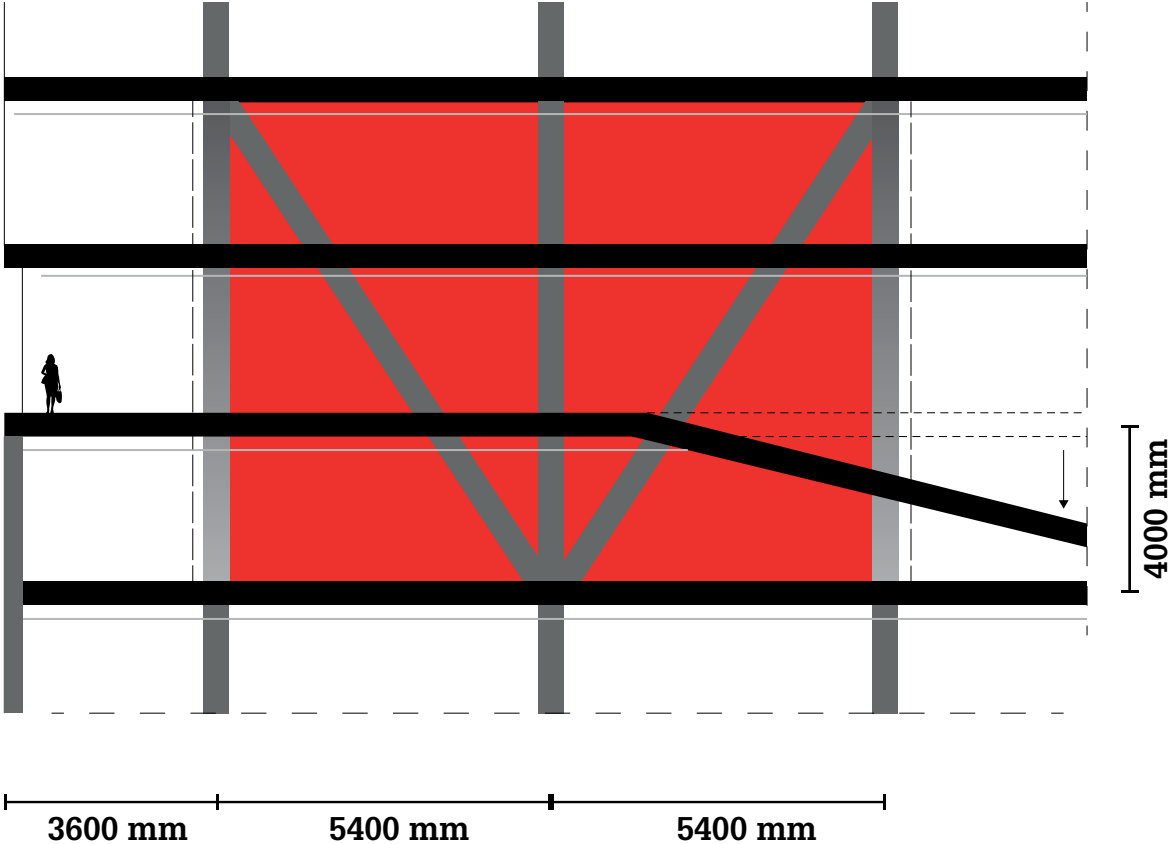

Construction

Bubbledeckflooring



Bubbledeckfloor around a Column. More strenght is needed.

Construction

Bubbledeckflooring



Little ventilationshafts are possible. For bigger, a systemceiling is needed.

Construction

Bubbledeckflooring



Construction

Principle

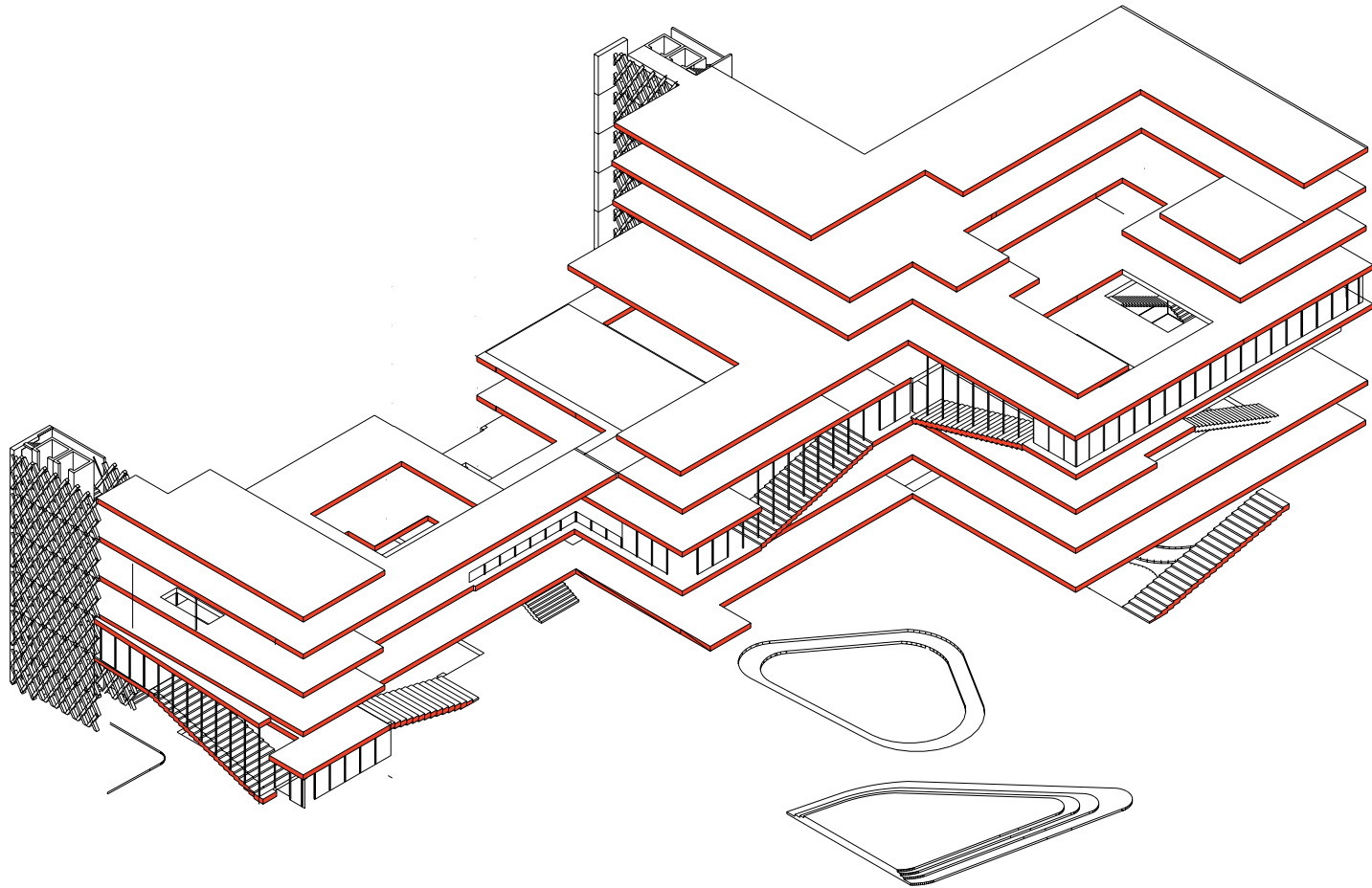

Construction

Principle

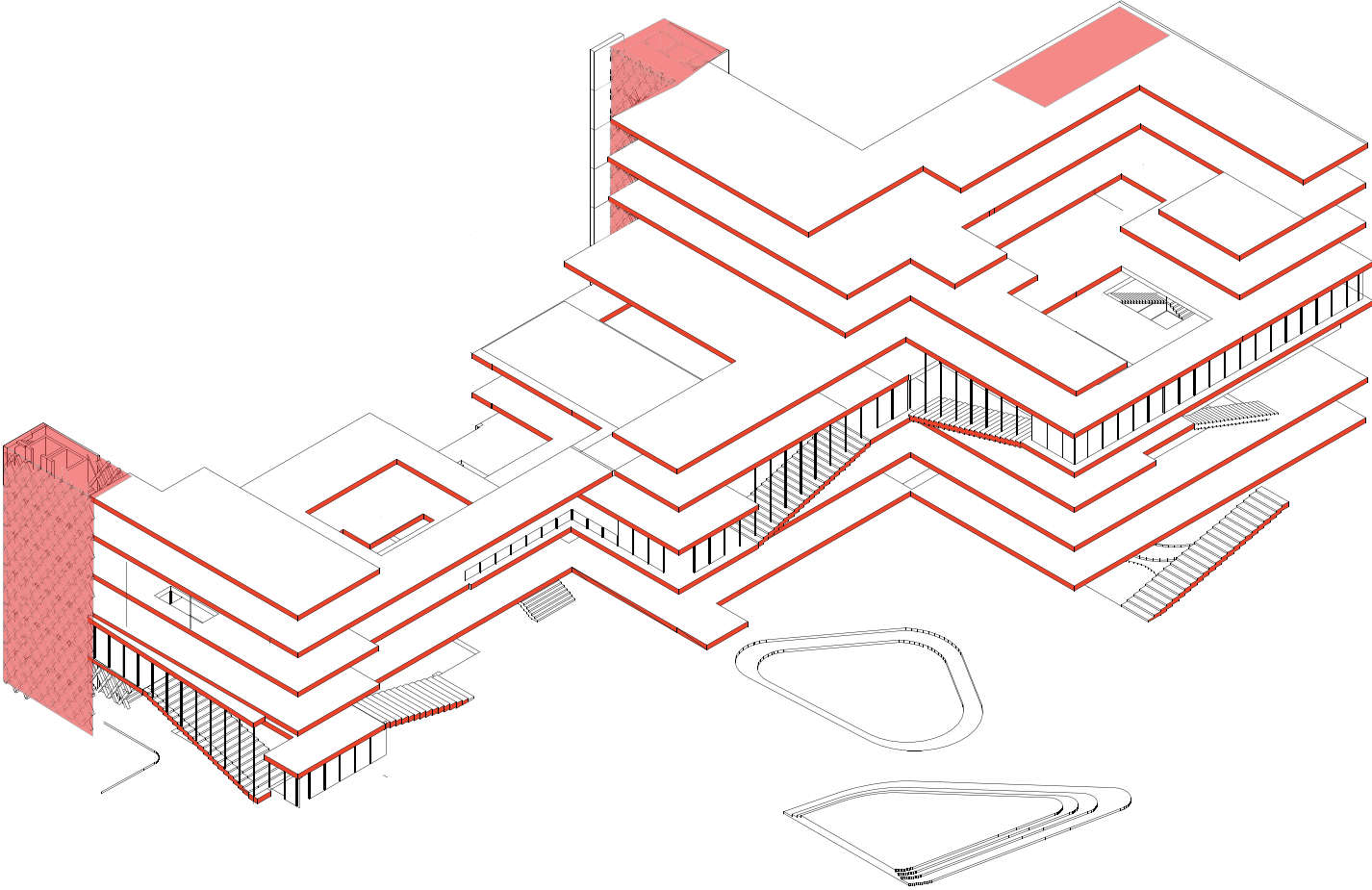

Construction

Principle

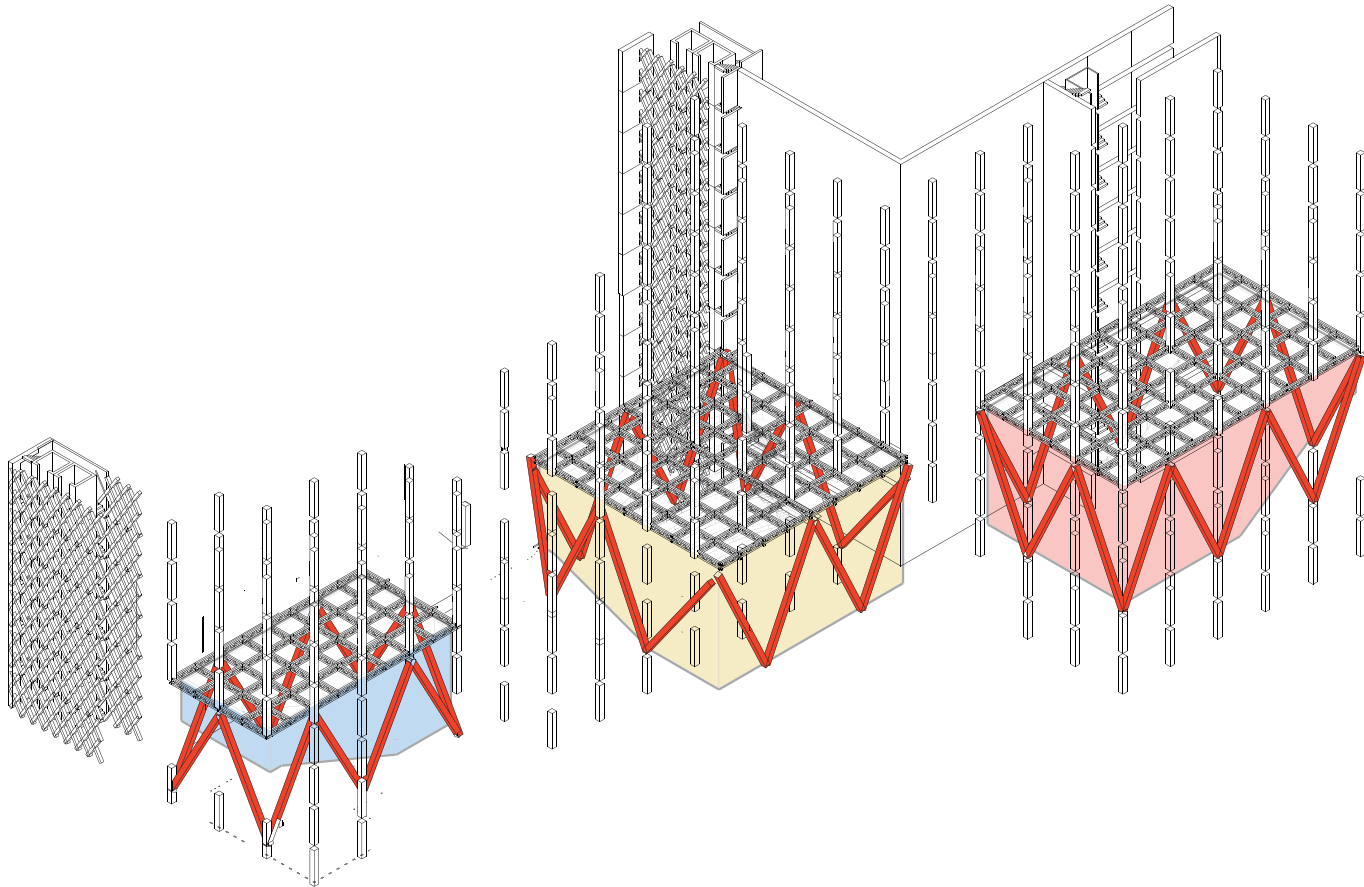

Construction

Detailing Patio

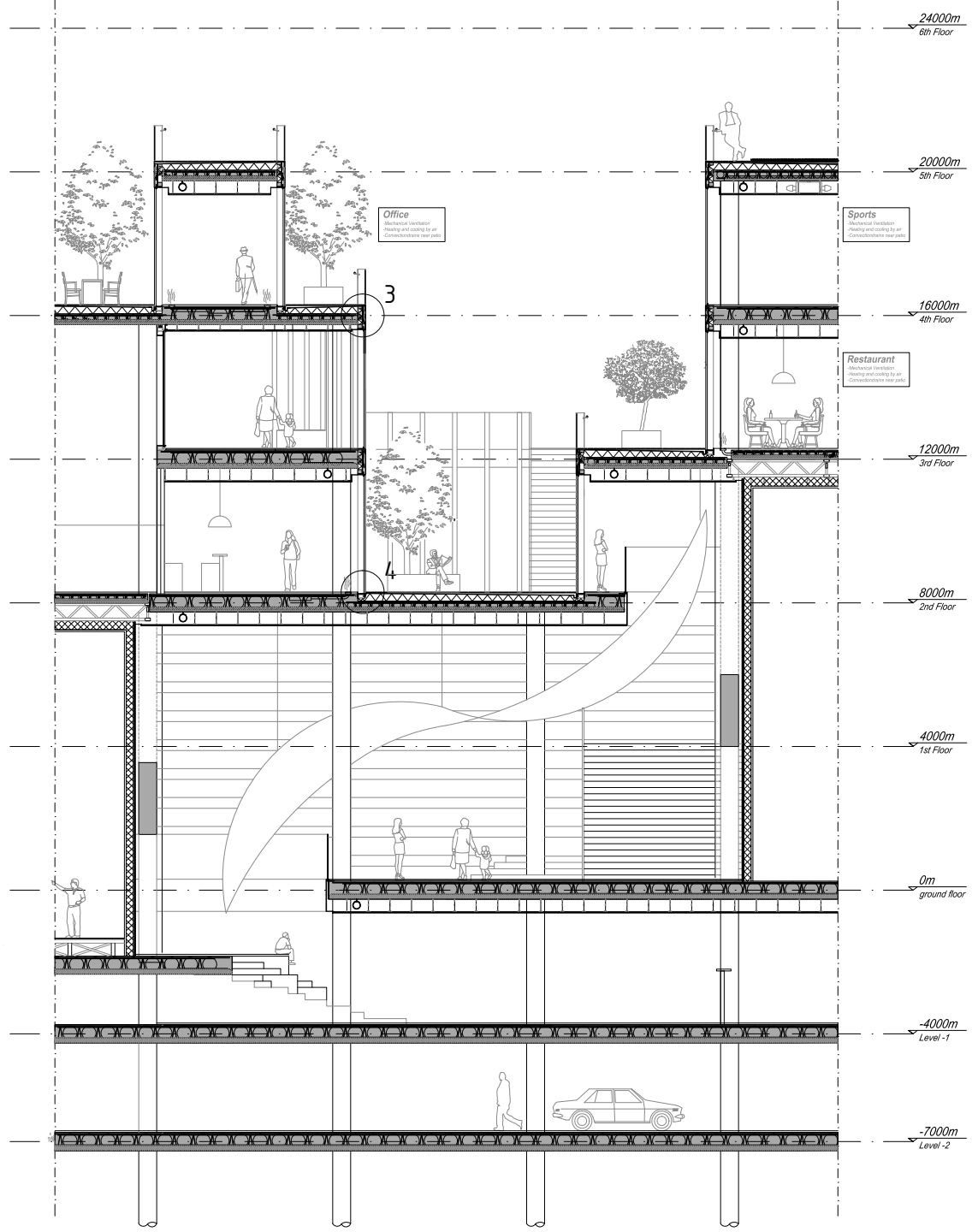
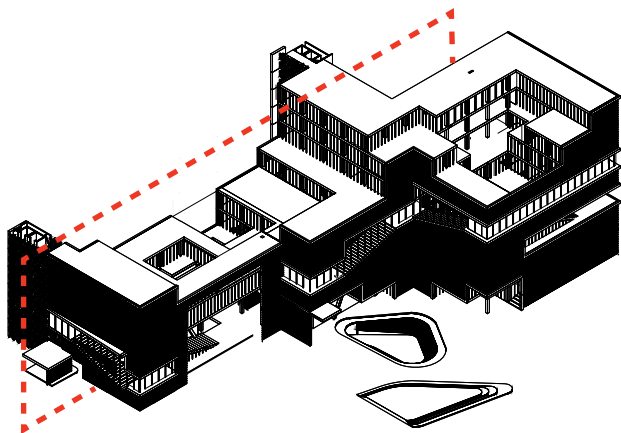

Construction

Detailing Patio

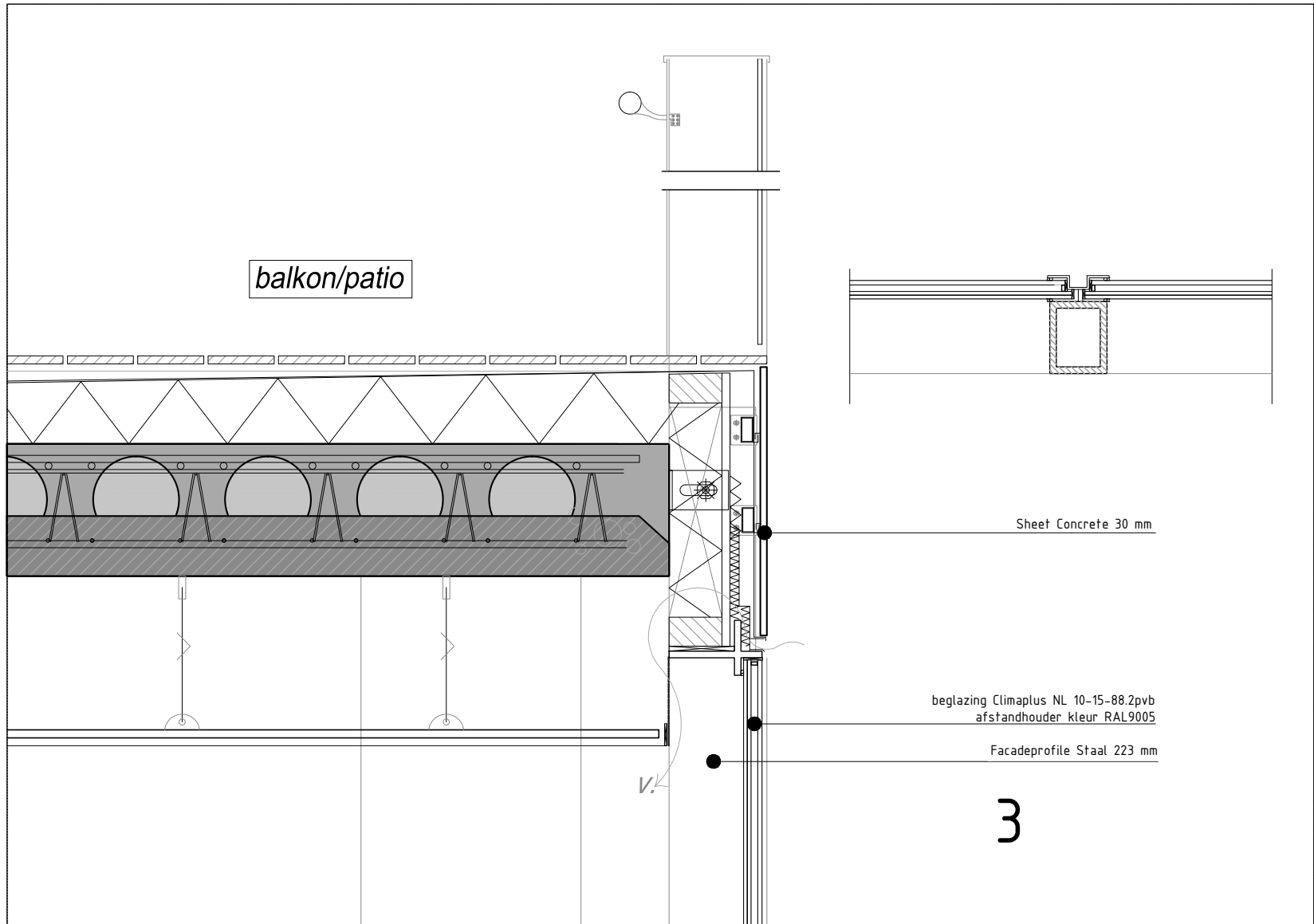

Construction

Detailing Patio

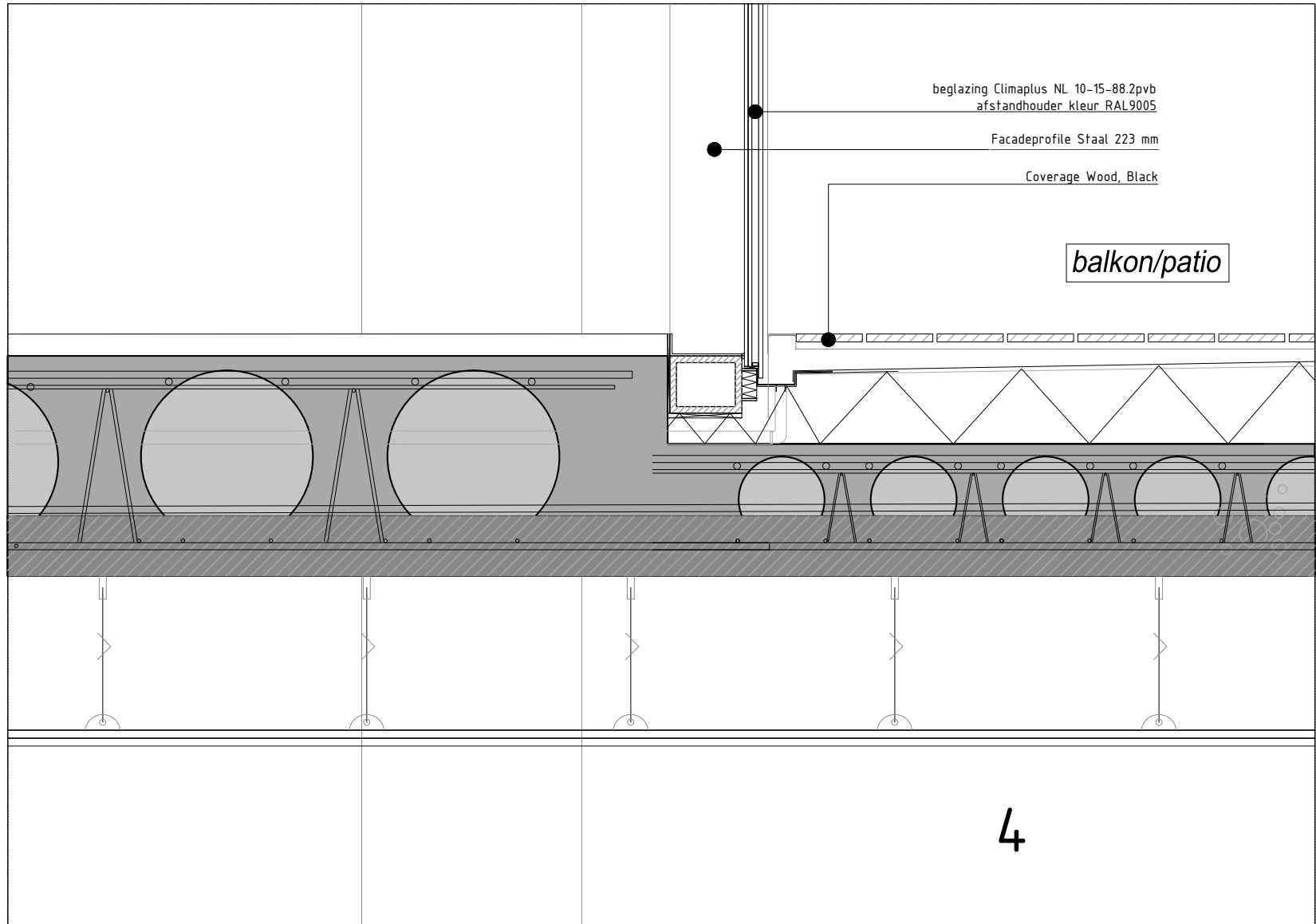

Construction

Detailing Facade

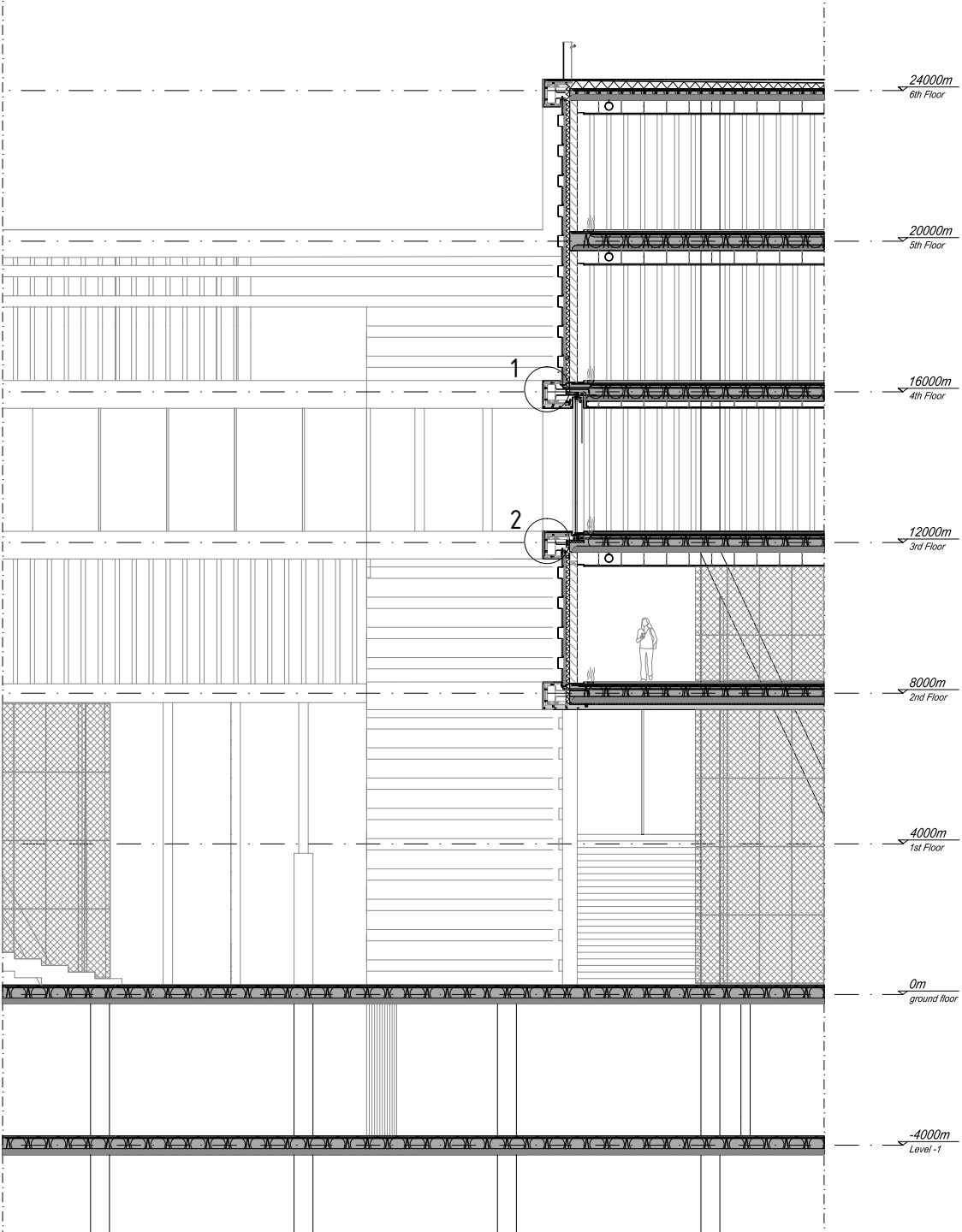
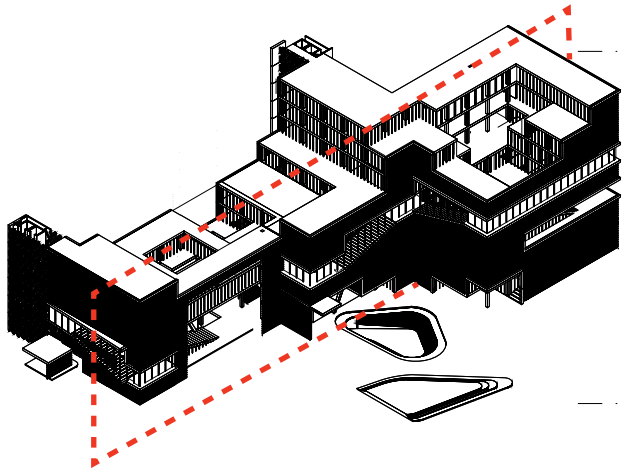

Construction

Detailing Facade

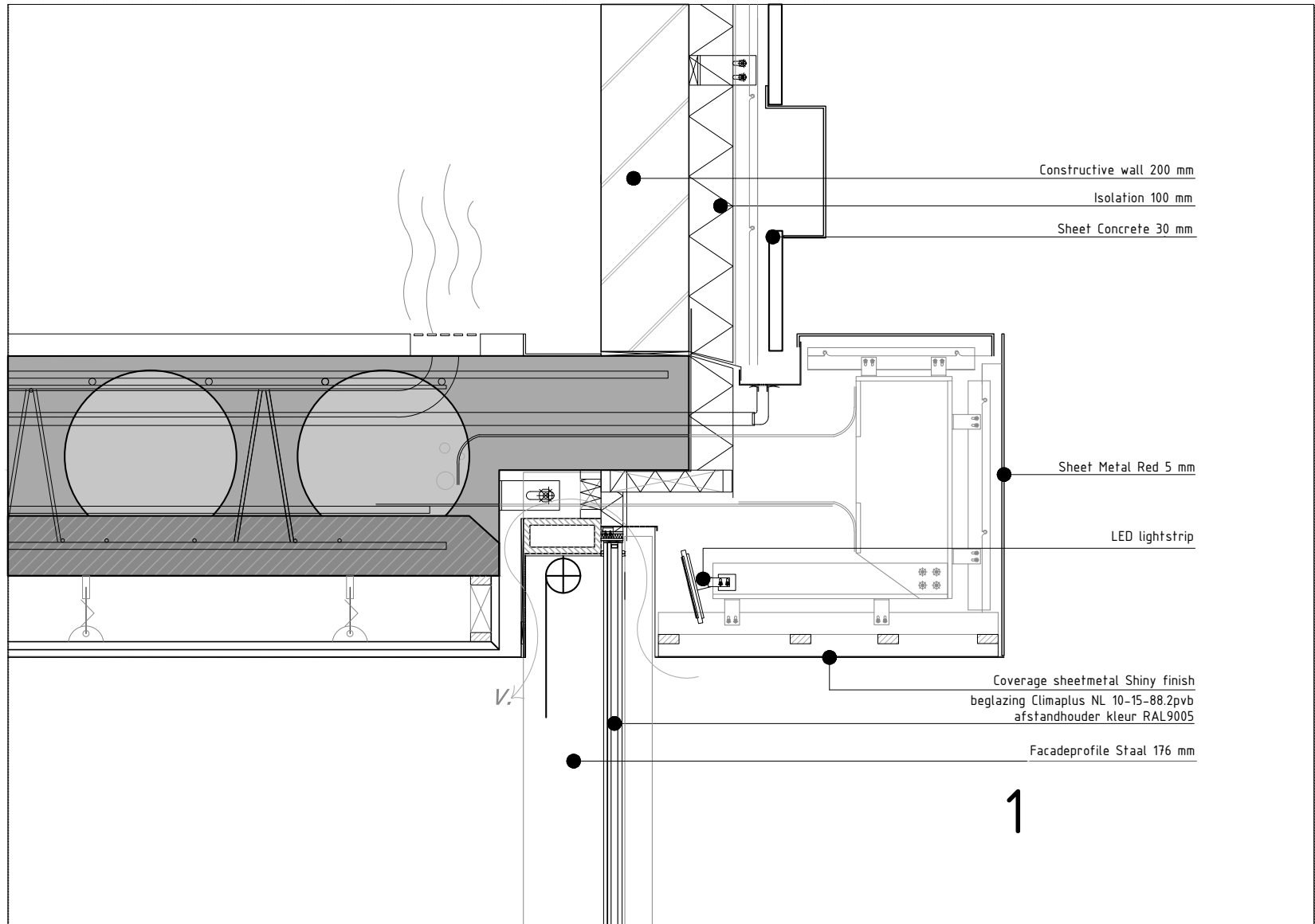

Construction

Detailing Facade

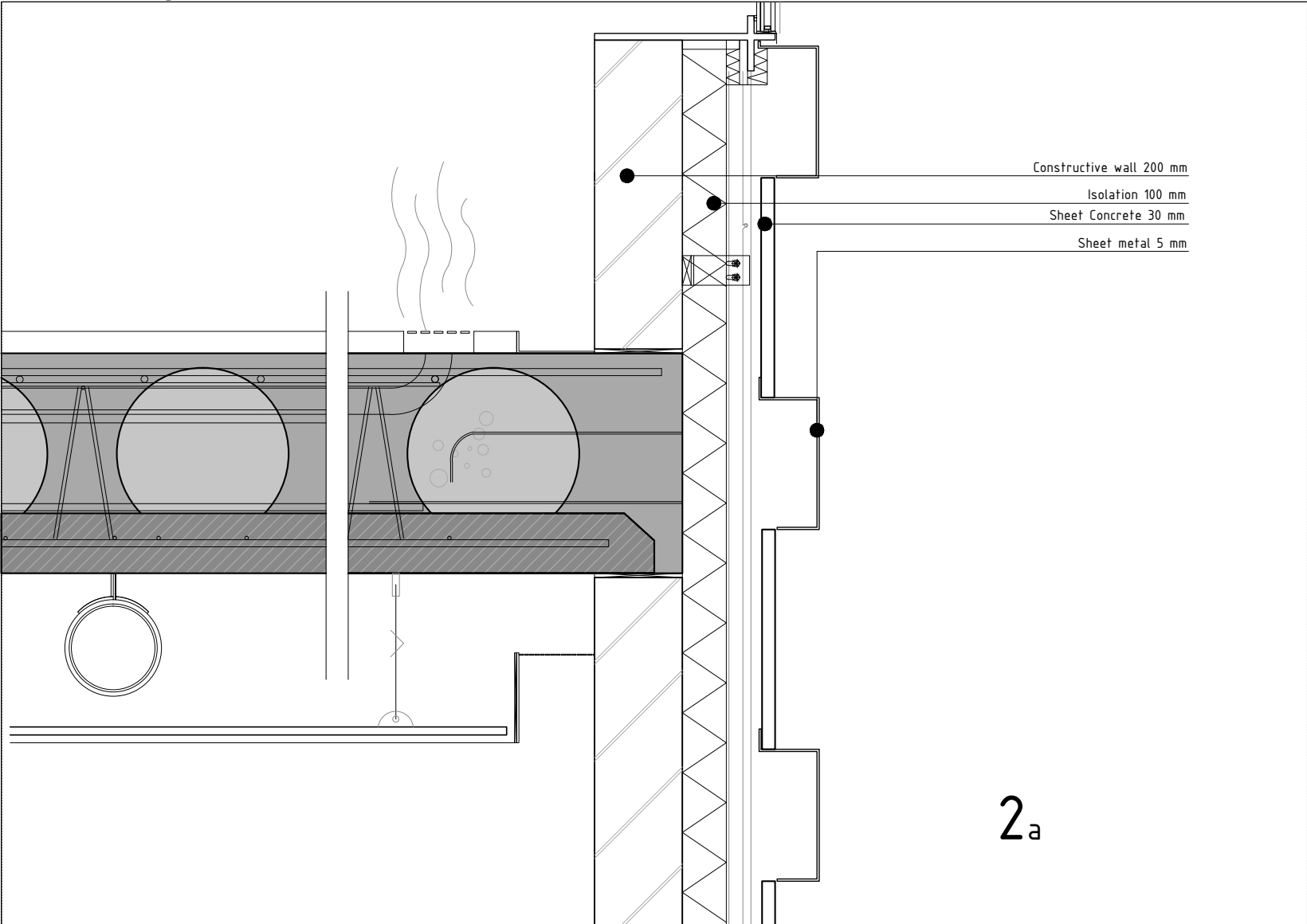



End



Special thanks to:

Jolanda Jole

Carlien van Soelen

Kim Swwchuurman

Joost van Nuland

Nishand Lochan

Rien Pels Rijcken

The extensive discussions and guidance of:

Nicola Marzot

Susanne Komossa

Jelke Fokkinga

Dirk de Groot

Gretha Kuurstra

And the collaboration with:

Kim Peeters

Aad Demerint

End