

Hydraulic Engineering and River Basin Development

River Training Works

Part 1: Lecture Notes
Part 2: River Training Structure

Hydraulic Engineering and River Basin Development

River Training Works

Part 1: Lecture Notes

Part 2: River Training Structure

UNESCO – IHE Institute for Water Education

Documentation to accompany the lectures of G. te Slaa - February 2004

PART 1 – Lecture notes

1 Subjects of this course

- General introduction/ recapitulation of some theory
- 'Local' river training schemes
- 'Large' river training schemes
- Channel regulation
- Water level regulation
- Discharge regulation (water and sediment!)
- Navigation
- River training works
- Functions, layouts, structural aspects, current attack, scour, construction aspects, contracting, environmental/ ecological aspects
- Dredging
- Exercise

2 General introduction

Often people (governments), authorities, companies, townships, etc) want to do 'something' with a river. Generally this can for two purposes:

- Realising a project, such as constructing a bridge across the river, or allowing inland navigation to take place
- Solving a problem, such as bank erosion problem or a eliminating or reducing the risk of flooding.

Frequently the wish to realise the purpose results in an engineering intervention to the river (system). This intervention can be fairly local, or it can encompass a very long stretch of river. Whatever the geographical influence of the intervention, it is always necessary to study and predict the behaviour of the river and its reaction on the intervention. Sometimes it is better not to go ahead with the intervention, because there may be unfavourable overall effects, or 'the cure may be worse than the disease'. In such a case it is better not to make the intervention, but to see if the project can be re-formulated or the problems can be solved in another manner.

Many elements needed for the study of the river and the design of the intervention have been covered in other lectures, like hydraulics, river morphology, river dynamics, soil mechanics, etc. Those disciplines are in any case needed to study the river and the potential intervention. In these lectures emphasis will be placed on the interaction between the river and the design of/ for the engineering interventions. The interventions usually comprise structures or dredging works. It is however also possible that for an existing river regulation scheme, the operating conditions are changed, for instance to place more emphasis on navigation and less on power generation. The changes regime will have consequences for the river morphology.

In these lectures only structural measures and dredging will be dealt with. Together they will be addressed under the common nominator: river training. These notes consist of two parts:

- A part that more or less covers the contents and sequence of the lectures, whereby much emphasis is placed on the interaction of between the river and the perceived intervention.

- A part that is derived from CUR manual 169 (The use of Rock In Hydraulic Engineering) – it concerns section 8 of said manual. Though it forms part of a manual that has been written specifically for the use of rock, the said chapter comprises a good design philosophy for river training structures, even if rock is not used as main construction material.

The basic approach advocated for engineering interventions in a river is:

- **What do we want to achieve?**
- **How can we achieve this, in other words: which tools do we have at our disposal to achieve our goals?**
- **How would the river react on the proposed scheme (often a structural measure or the implementation of dredging works)?**
- **Is the reaction of the river acceptable? (from many points of view, such as safety, costs, environment, socially, short term and long term effects, etc.)**
- **If this is the case, do we have to adjust the scheme as designed to take account of the changes of the river to be expected?**
- **Are there alternatives to achieve our goal?**
- **Frequently it will be necessary to approach the problem or project in an iterative manner – the final answer seldom is arrived at the first attempt.**

3 Rivers

Rivers have many things in common, but there are also big differences. Some of them are briefly discussed below

- Common aspects (functions/ properties)
- Differences (nature)
- Differences (human use)

3.1 *Common aspects*

- Transport of water (also in the form of ice) – sometimes completely dry river
- Transport of sediment (coarse and fine)

3.2 Differences

3.2.1 Length, discharge

The table of some large rivers is given hereafter – note the big differences in length and discharge.

Name of river	Length (km)	High discharge (m ³ /s)
Amazon (Brazil)	6700	200,000
Yangtze Kiang (China)	5600	80,000
Brahmaputra (Bangladesh)	2900	90,000
Ganges (India/Bangladesh)	2500	60,000
Niger (Africa)	4100	30,000
Donau (Germany, etc.)	2900	17,000
Rhine (Switzerland, Germany, Netherlands)	1300	15,000
Murray-Darling (Australia)	3700	1,100

3.2.2 Hydrograph (level difference, seasonal variation)

Some different hydrographs are given in the following graphs – it should be realized that the behaviour will also have its influence on the design of any river training works, as the working conditions (seasonal or permanent) will have an influence on what can be constructed and what not

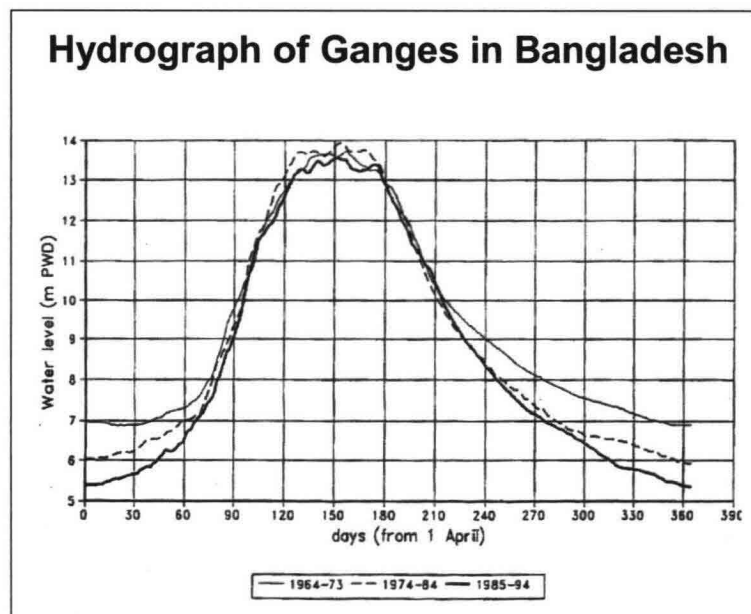

Hydrographs – Rio Magdalena & River Niger

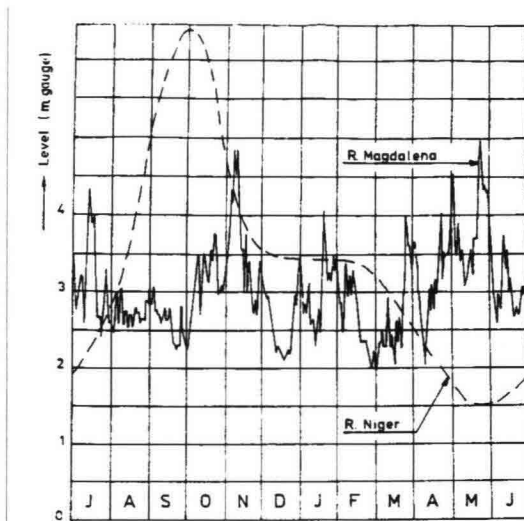

3.2.3 Slope gradient

When asked about a general order of magnitude of a river (without any further particulars), the best answer is probably 1:10,000. In the following figures gradients of some mayor rivers are given. Note the difference between slope in the upper and lower reaches.

Slope gradient

Indications

- Upper region 1 : 5,000
- Middle region 1 : 10,000
- Lower region 1 : 20,000

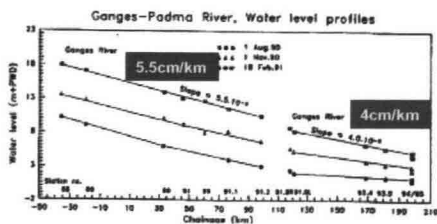
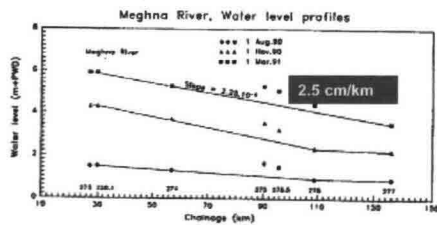
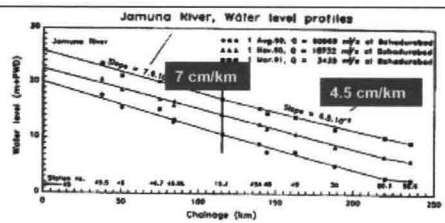

Slope gradient - Donau

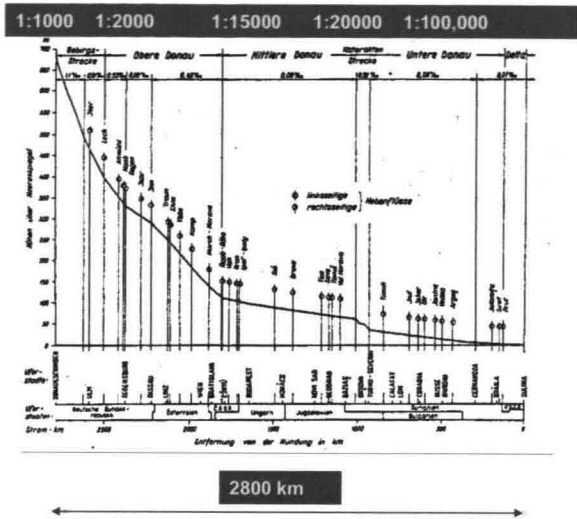

3.2.4 Bank and bed material (coarse, fine, cohesive)

3.2.5 Geological controls

Geological control – Mahaweli River - Sri Lanka

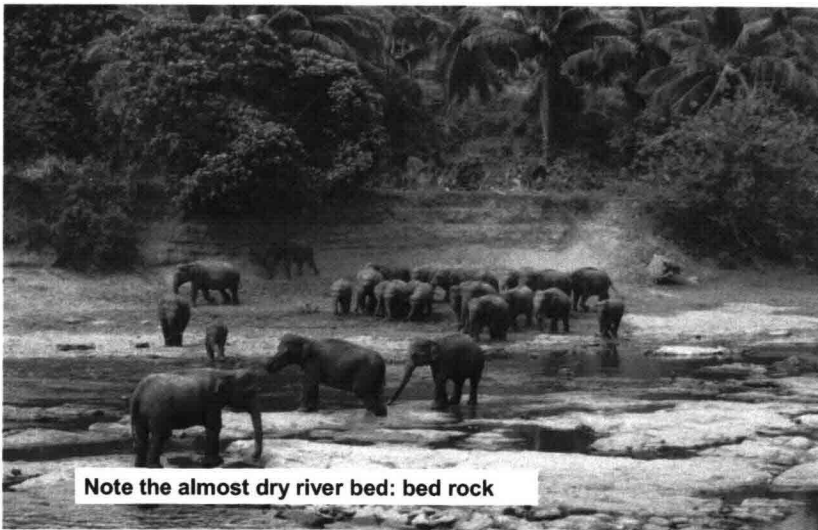

Geological controls - Padma (Bangladesh)

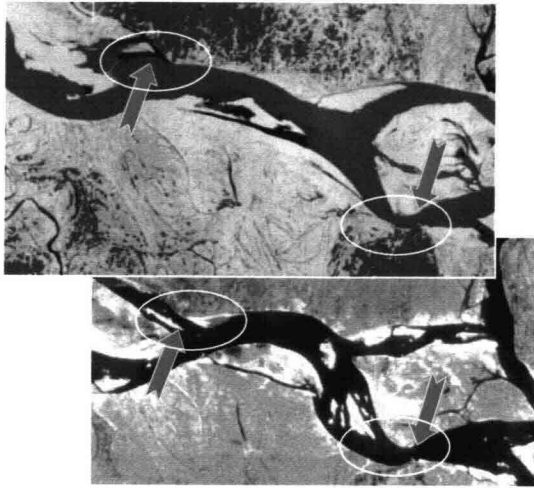

3.2.6 Number of channels (meandering , braiding)

Meandering & braiding rivers

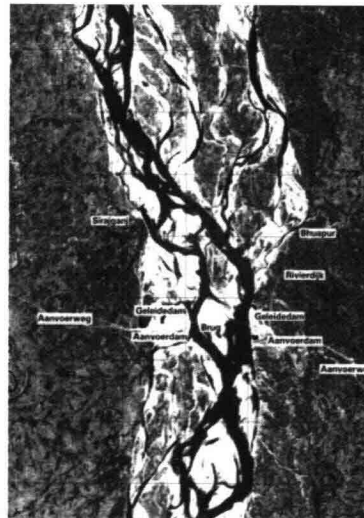
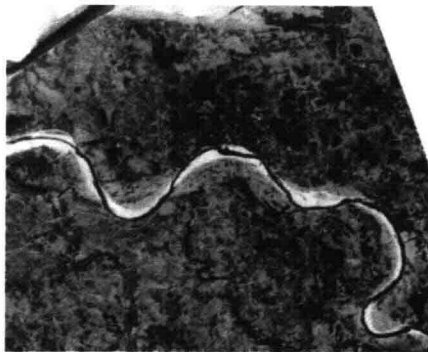

3.2.7 Tributaries and distributaries, spill channels

4 Main River engineering themes

- Channel control
- Water level control
- Discharge control
- Flood protection

4.1 Channel control

4.1.1 Purposes

- Erosion control
- River bank protection
- Guiding of flow to structures
- Navigation
- Flood protection
- Land reclamation

4.1.2 How to pursue the purposes?

- To influence the plan form
- cross sections
- longitudinal profile
- water and sediment distribution (at distributaries)

4.2 Water level control

4.2.1 Purposes

- Navigation
- Irrigation, water supply
- Distribution over distributaries/ branches
- Power generation

4.2.2 How to pursue the purposes?

Basically with structures across the river

- Fixed/ movable
- Adjustable/ non-adjustable

4.3 Discharge control

4.3.1 Purposes

- Hydropower
- Agriculture
- Water supply
- Flood protection
- Salinity control

4.3.2 How to pursue the purposes?

- Storage in reservoirs
- Storage in floodplains/ retention basins
- Construction of dams, barrages

4.4 Flood protection

4.4.1 Purposes

- Reduce flooding
- Lower risk of flooding

4.4.2 How to pursue the purposes?

- Construction of new dikes
- Strengthening of existing dikes
- Retention
- Through discharge control

5 Tools for engineering interventions

- Temporary works
- Permanent works

5.1 Temporary works

5.1.1 Bandalls

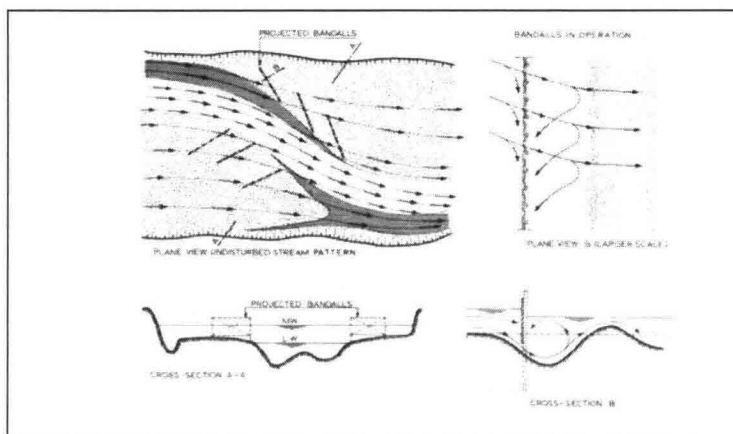

5.1.2 Dredging

- Bucket and grab dredgers
- Suction and cutter-suction dredgers
- Trailing hopper dredgers

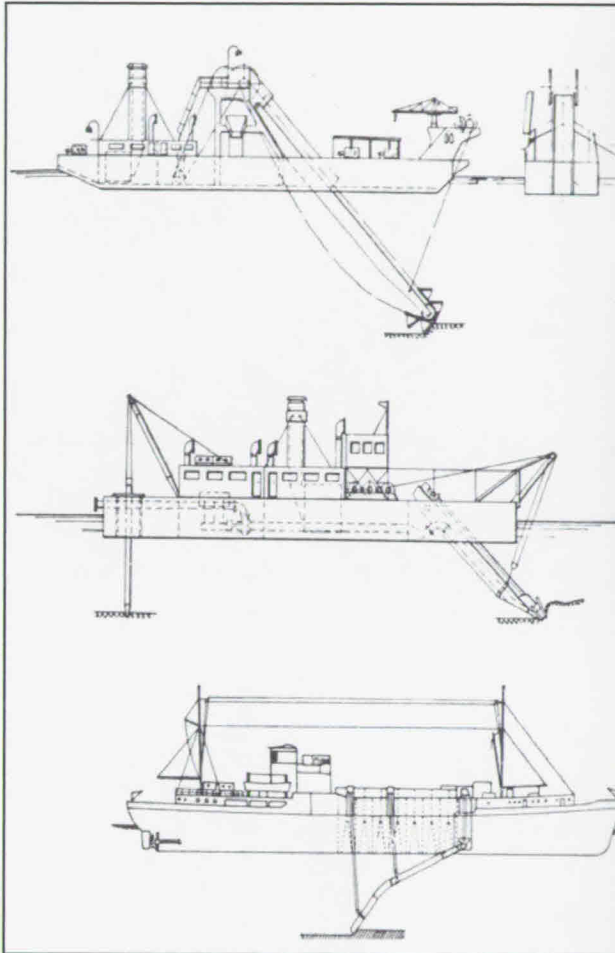

5.1.3 Surface panels

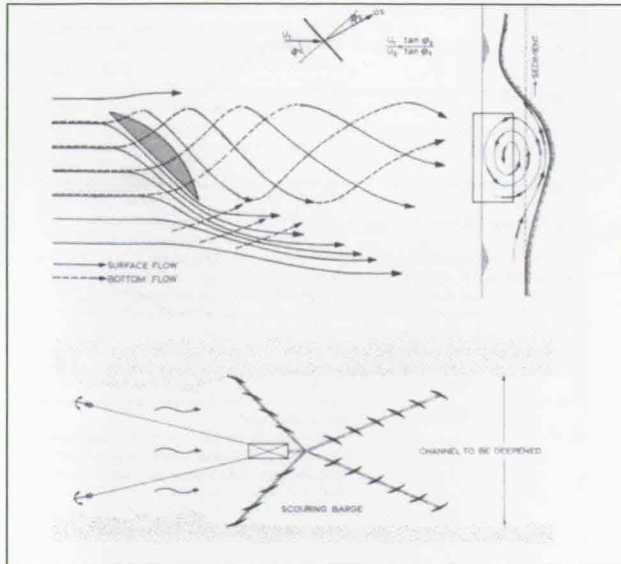

5.1.4 Temporary groynes

5.1.5 Emergency measures

5.2 Permanent work – tools

- Closure of river branches and estuaries
- Short-cutting of river bends
- Flow guiding structures
- Embankments
- Bank & bed protection
- Dredging
- Elimination of obstacles
- Weirs and barrages
- Other structures, like navigation locks, fish traps, intake structures

5.2.1 Closure of river branches and estuaries

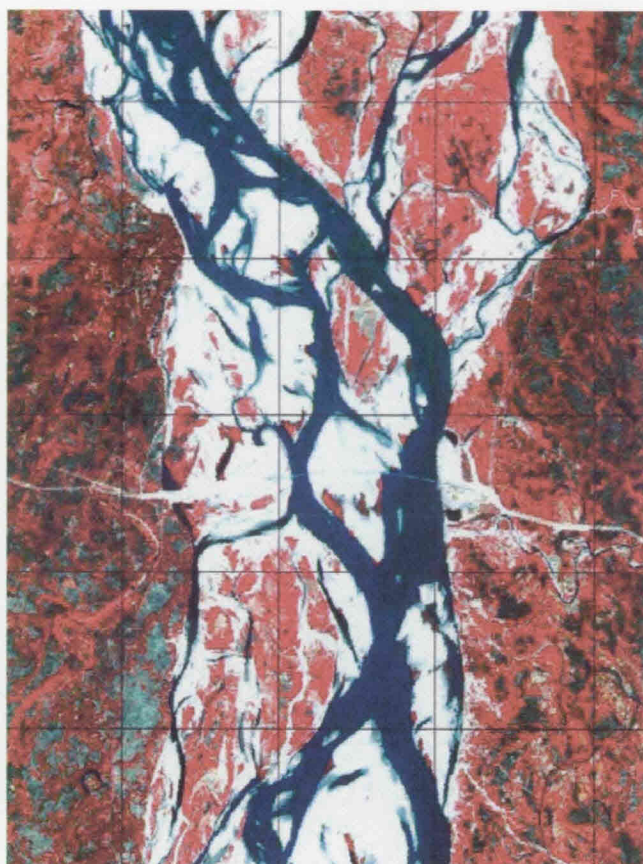

5.2.2 Short-cutting of river bends

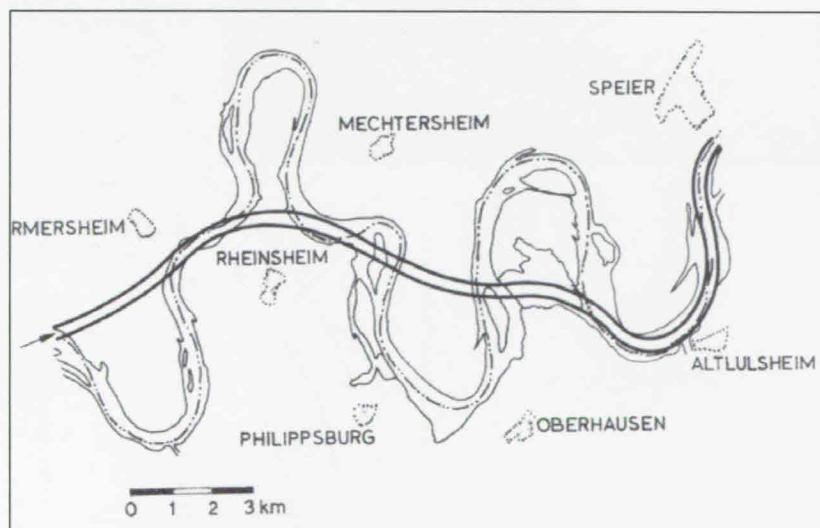

5.2.3 Flow guiding structures

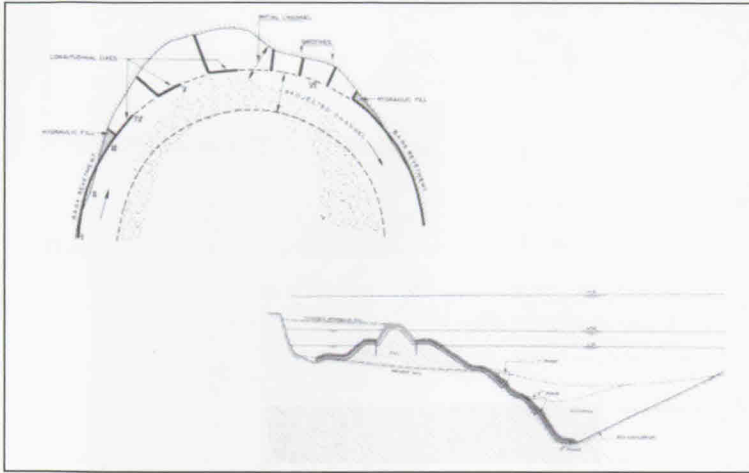

5.2.4 Embankments and revetments



5.2.5 Dredging

Same type of equipment used as for temporary works

5.2.6 Elimination of obstacles

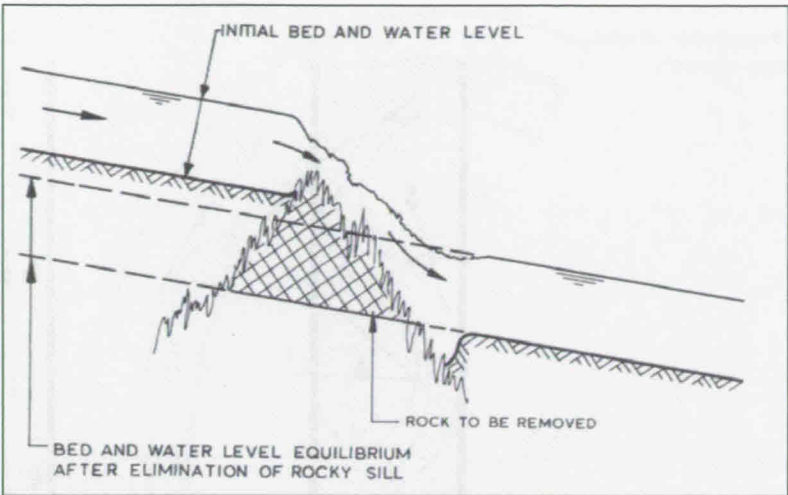

5.2.7 Weirs and barrages

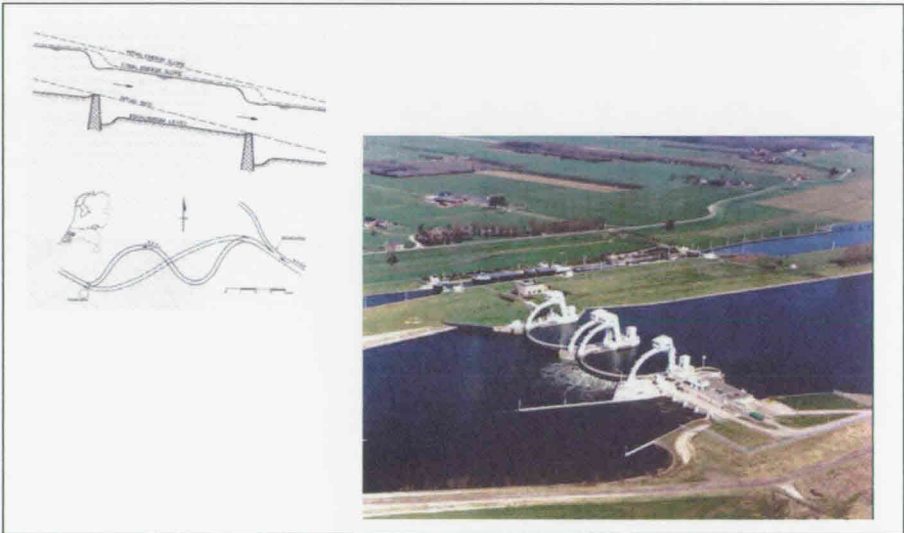

6 Recapitulation of some theory

- Basic equations for transient flow
- Simplifications for specific cases
- One dimensional flow
- No inertia forces
- No friction
- Et cetera
- Transport of sediment
- Relation between water level gradient and sediment transport

6.1 Continuity - water

Volume 'out' - volume 'in' = 0

$$\left(v_x + \frac{\partial v_x}{\partial x} \cdot dx \right) \cdot dy \cdot dz \cdot dt - v_x \cdot dy \cdot dz \cdot dt$$

$$\left(v_y + \frac{\partial v_y}{\partial y} \cdot dy \right) \cdot dx \cdot dz \cdot dt - v_y \cdot dx \cdot dz \cdot dt$$

$$\left(v_z + \frac{\partial v_z}{\partial z} \cdot dz \right) \cdot dx \cdot dy \cdot dt - v_z \cdot dx \cdot dy \cdot dt$$

$$\frac{\partial v_x}{\partial x} + \frac{\partial v_y}{\partial y} + \frac{\partial v_z}{\partial z} = 0$$

Alternative notation:

$$\frac{\partial u}{\partial x} + \frac{\partial v}{\partial y} + \frac{\partial w}{\partial z} = 0$$

$$\frac{\partial q_x}{\partial x} + \frac{\partial h}{\partial t} = 0$$

or, with $q_x = v_x \cdot h$ (h = water depth)

$$h \cdot \frac{\partial v_x}{\partial x} + v_x \cdot \frac{\partial h}{\partial x} + \frac{\partial h}{\partial t} = 0$$

For river with groynes:

$$\frac{\partial Q}{\partial x} + B \cdot \frac{\partial h}{\partial t} = 0, \text{ with } B = \text{storage width}$$

or, with $Q = B_s \cdot q$, with B_s = stream width:

$$\frac{\partial (B_s \cdot q_x)}{\partial x} + B \cdot \frac{\partial h}{\partial t} = 0$$

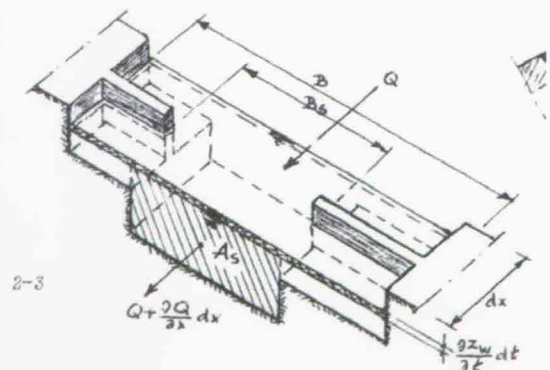

6.2 Water - Equation of motion

Equation of motion according to Euler:

$$\frac{du}{dt} = \frac{\partial u}{\partial t} + u \frac{\partial u}{\partial x} + v \frac{\partial u}{\partial y} + w \frac{\partial u}{\partial z} = -\frac{1}{\rho} \frac{\partial p}{\partial x} + X$$

$$\frac{dv}{dt} = \frac{\partial v}{\partial t} + u \frac{\partial v}{\partial x} + v \frac{\partial v}{\partial y} + w \frac{\partial v}{\partial z} = -\frac{1}{\rho} \frac{\partial p}{\partial y} + Y$$

$$\frac{dw}{dt} = \frac{\partial w}{\partial t} + u \frac{\partial w}{\partial x} + v \frac{\partial w}{\partial y} + w \frac{\partial w}{\partial z} = -\frac{1}{\rho} \frac{\partial p}{\partial z} + Z$$

Permanent flow: $\frac{\partial u}{\partial t}, \frac{\partial v}{\partial t}, \frac{\partial w}{\partial t} = 0$

$\frac{\partial u}{\partial s} = 0$: stationary flow,

$\frac{\partial u}{\partial s} \neq 0$: non-stationary flow

Non-permanent flow: $\frac{\partial u}{\partial t}, \frac{\partial v}{\partial t}, \frac{\partial w}{\partial t} \neq 0$

(Long waves, short waves)

6.3 Water - Equation of motion (1D)

Various forms:

$$\frac{\partial Q}{\partial t} + \frac{\partial}{\partial x} \left(\alpha' \frac{Q^2}{A_s} \right) + g A_s \left(\frac{\partial h}{\partial x} - i_b \right) + g \frac{Q|Q|}{C^2 A_s R} = 0$$

(note the use of α' and $Q|Q|$)

or:

$$\frac{1}{g A_s} \frac{\partial Q}{\partial t} - \frac{2B}{g A_s^2} Q \frac{\partial h}{\partial t} + \frac{\partial h}{\partial x} - i_b + \frac{Q|Q|}{C^2 A_s^2 R} = 0$$

or:

$$\frac{\partial u}{\partial t} + u \frac{\partial u}{\partial x} + g \frac{\partial h}{\partial x} - g i_b + g \frac{u|u|}{C^2 h} = 0$$

One more form, as in Janssen - Principles of River Engineering
(time derivatives, omitted, thus permanent flow)

$$\left(1 - \alpha \frac{Q^2 B_s}{g A_s^3}\right) \frac{\partial h}{\partial x} - i_b + \frac{Q |Q|}{C^2 R A_s^2} - \alpha \frac{Q^2}{g A_s^3} \frac{\partial A_s}{\partial x} \Big|_h = 0$$

Now, when $\frac{\partial A_s}{\partial x} = 0$ (prismatic river):

$$\frac{\partial h}{\partial x} = i_b \frac{1 - \frac{Q |Q|}{C^2 R A_s^2 i_b}}{1 - \alpha \frac{Q^2 B_s}{g A_s^3}} \quad \text{This is the backwater curve for steady flow.}$$

6.4 Sediment - Continuity

$$\frac{\partial S}{\partial x} + B \frac{\partial z}{\partial t} = 0$$

6.5 Sediment – transport equations

Van Rijn:

$$q_b = 0.005 \left(\frac{u - u_{cr}}{(\Delta \cdot g \cdot D_{50})^{0.5}} \right)^{2.4} \cdot \left(\frac{D_{50}}{h} \right) \cdot u \cdot h$$

$$q_s = 0.012 \left(\frac{u - u_{cr}}{(\Delta \cdot g \cdot D_{50})^{0.5}} \right)^{2.4} \cdot \left(\frac{D_{50}}{h} \right) \cdot D_*^{-0.6} \cdot u \cdot h, \text{ with } D_* = D_{50} \cdot \left(\frac{\Delta \cdot g}{v^2} \right)^{\frac{1}{3}}$$

Engelund-Hansen:

$$s = \frac{0.05 \cdot u^5}{\Delta^2 \cdot \sqrt{g} \cdot D_{50} \cdot C^3}$$

Meyer-Peter and Mueller:

$$s = 7.98 \cdot \left(\frac{C^{0.5} \cdot u^2}{C_{90}^{1.5} \cdot \Delta \cdot \bar{D}} - 0.047 \right)^{1.5} \cdot \bar{D}^{-1.5} \cdot \sqrt{g} \cdot \Delta^{0.5}, \text{ with } C_{90} = \frac{\sqrt{g}}{\kappa} \ln \left(\frac{12 \cdot R}{D_{90}} \right)$$

General:

$$s = a \cdot u^b; \quad S = B \cdot a \cdot u^b$$

All relevant information on D , Δ , μ , etc. is taken care of in a and b

Different notation (expressed in i rather than u):

Meyer-Peter and Mueller:

$$\frac{s}{D^{\frac{3}{2}} \cdot \sqrt{g \cdot \Delta}} = 13.3 \cdot \left(\frac{\mu \cdot h \cdot i}{\Delta \cdot D} - 0.047 \right)^{1.5}$$

Engelund-Hansen:

$$\frac{s}{D^{\frac{3}{2}} \cdot \sqrt{g \cdot \Delta}} = 0.084 \left(\frac{\mu \cdot h \cdot i}{\Delta \cdot D} \right)^{\frac{5}{2}}$$

6.6 Application - constriction of river

Water:

$$Q_0 = Q_1 = B_0 \cdot h_0 \cdot u_0 = B_1 \cdot h_1 \cdot u_1$$

$$Q_{0,1} = B_{0,1} \cdot C \cdot h_{0,1}^{\frac{3}{2}} \cdot i_{0,1}^{\frac{1}{2}}$$

Sediment:

$$S_0 = S_1$$

$$S_{0,1} = B_{0,1} \cdot a \cdot u_{0,1}^b$$

With some elementary algebra it can be shown that:

$$\frac{h_1}{h_0} = \left(\frac{B_0}{B_1} \right)^{\frac{b-1}{b}}, \quad \text{and} \quad \frac{i_1}{i_0} = \left(\frac{B_1}{B_0} \right)^{\left(1 - \frac{3}{b}\right)}$$

Note that the factor b is often somewhere between 4 and 6.

The above results are very useful when determining the impact of river widening or narrowing: the new final equilibrium depth and the hydraulic gradient can be determined when discharge, present depth, width and gradient are known. Be aware that this formally should only be used for the circumstances for which it has been derived: permanent flows in prismatic channels!

7 Design aspects of river training works

- Scour
- Current attack
- Wave attack (wind waves, ship's waves, translation waves (return currents))
- Protective materials
- Slope stability – general, earthquake, seepage
- Open/ closed protections and filters

7.1 Scour

- General scour/ aggradation
- Autonomous development, incomplete adjustment
- Constriction scour
- Bend scour
- Confluence scour
- Protrusion scour
- Local scour
- Clear water scour/ sediment supply

7.1.1 General scour/ aggradation

7.1.2 Bend scour

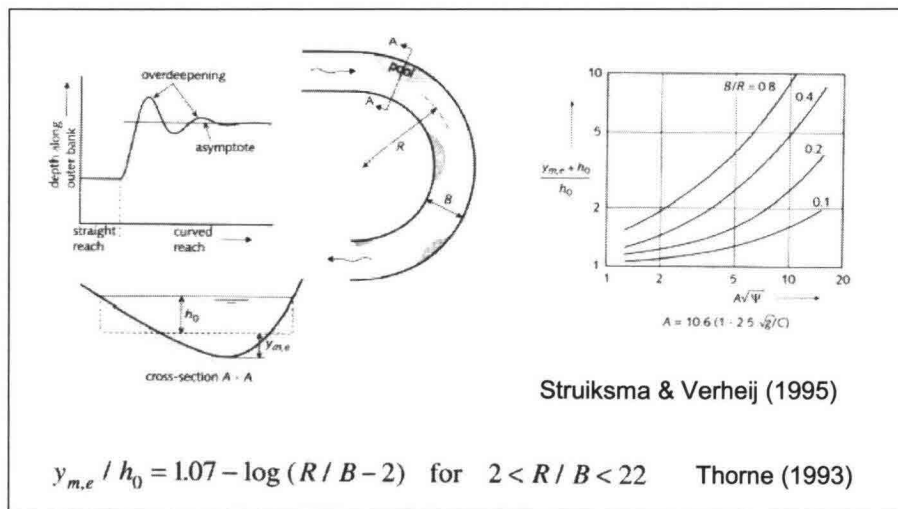

7.1.3 Confluence scour

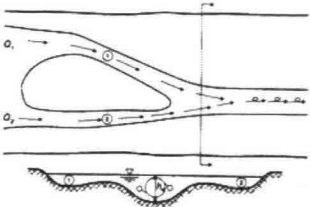

Figure 5.99 Confluence scour

$$y_{m,e} / h_0 = c_0 + 0.037 \theta$$

in which: c_0 = coefficient depending on material properties (-),
 $c_0 = 1.29-2.24$,
 h_0 = average flow depth of the two branches (m)
 $y_{m,e}$ = equilibrium scour depth (m)
 θ = angle between the two upstream branches

7.1.4 Local scour

Local scour – bridge pier

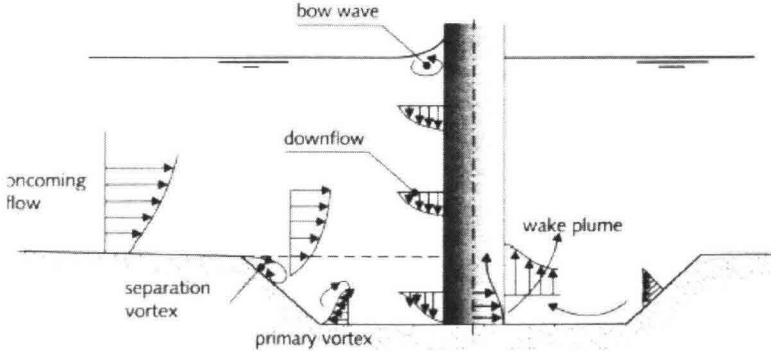
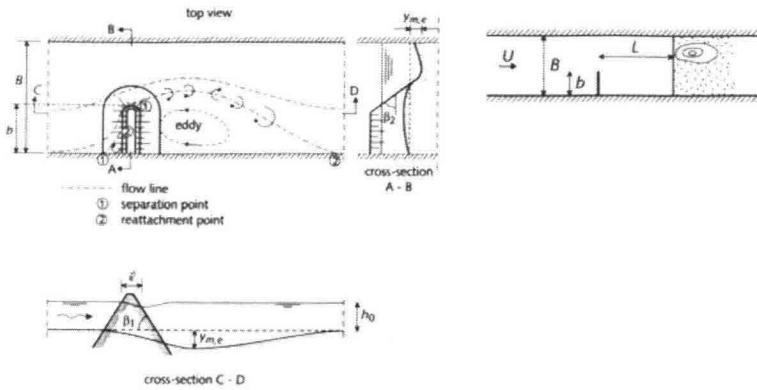

diagram of various fields of turbulence associated with surge-induced flow

Local scour – groynes, abutments



$$y_{m,e} = h_0 \left((1-m)^{-2/3} - 1 \right) + K_b b \tanh(h_0 / b) \quad \text{for } U_0 > U_c \quad \text{Hoffmans, 1995}$$

$$m = b/B$$

7.1.5 Combinations of scour

Combined bend and local scour

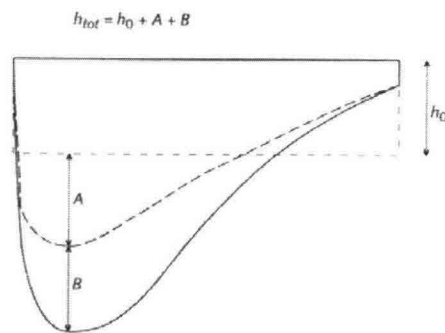

h_0 = average depth in straight channel without abutment

A = bend scour (without abutment)

B = local scour due to abutment in straight channel

7.1.6 Local scour behind a weir or sill

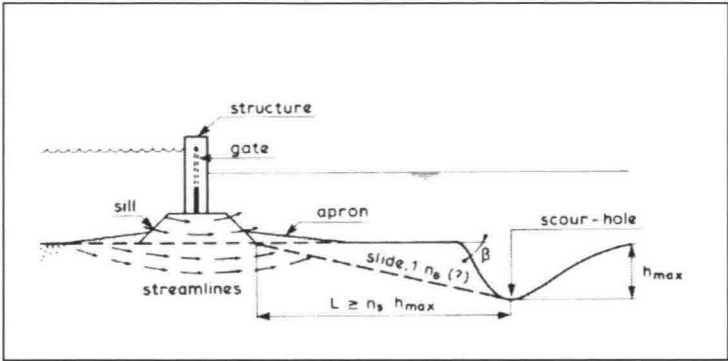

Development of velocity profile behind a weir

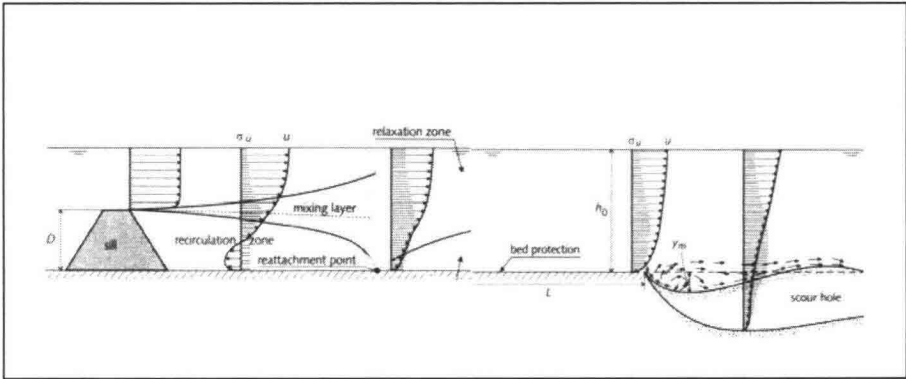

7.2 Current attack

- Izbasch: $\Delta \cdot D = 0.7 \cdot \frac{u_c^2}{2 \cdot g}$
- Modifications, to take account of
 - Position along structure
 - Turbulence
 - Smoothness of protection
 - Slope gradient
 - Depth factor (fully developed or not fully-developed velocity profile)
- Pilarczyk

Formula of Pilarczyk

$$\Delta_m \cdot D_n = \phi \cdot K_t \cdot \frac{0.035}{\Psi_{cr}} \cdot \frac{K_h}{K_s} \cdot \frac{u^2}{2 \cdot g}$$

Much attention to be paid to correct values for:

- ϕ stability parameter (0.5 to 1.25)
- K_t turbulence factor (1.0 to 3.0)
- Ψ Shields value (0.03 to 0.05)
- K_h depth factor (0.4 to 1.0)
- K_s slope factor (0.6 to 1.0)

Parameters used in formula of Pilarczyk

- $\Delta_m = \frac{\rho_m - \rho_w}{\rho_w}$ = relative mass density of submerged protective element,
- ρ_m = mass density of protective element [kg/m³],
- ρ_w = mass density of water [kg/m³],
- D_n = characteristic diameter for protective element,
- ϕ = stability parameter; the following values apply: 0.5 for continuous block mattress, 0.75 for rock mattress (min. layer thickness 2 stones, 1.00 for edges of block mattresses, 1.25 for edges of rock mattress),
- K_t = turbulence factor; the following values apply: 1.0 for normal turbulence in rivers, 1.5 for non-uniform flow in outer river bends (radius / river width >2); 2.0 for high turbulence as in local disturbances, such as sharp outer bends; 3.0 for jet impacts, other very high turbulence situations,
- Ψ_{cr} = critical shear stress parameter,

K_s = slope coefficient = $\sqrt{1 - \frac{\sin^2 \alpha}{\sin^2 \varphi}}$, with α = slope angle and φ = angle of internal friction of slope protection material,

K_h = $\left(\frac{h}{D_n}\right)^{-0.2}$, for not fully developed velocity profile, where h is water depth,
or

= $\frac{2}{\left(\log \frac{10 \cdot h}{(2 \text{ to } 5) \cdot D_n}\right)^2}$, for fully developed logarithmic velocity profile,
(3 * D_n is used here, h = water depth for critical situation),

u = velocity of water (averaged over vertical) [m/s],

g = acceleration of gravity [m/s²]

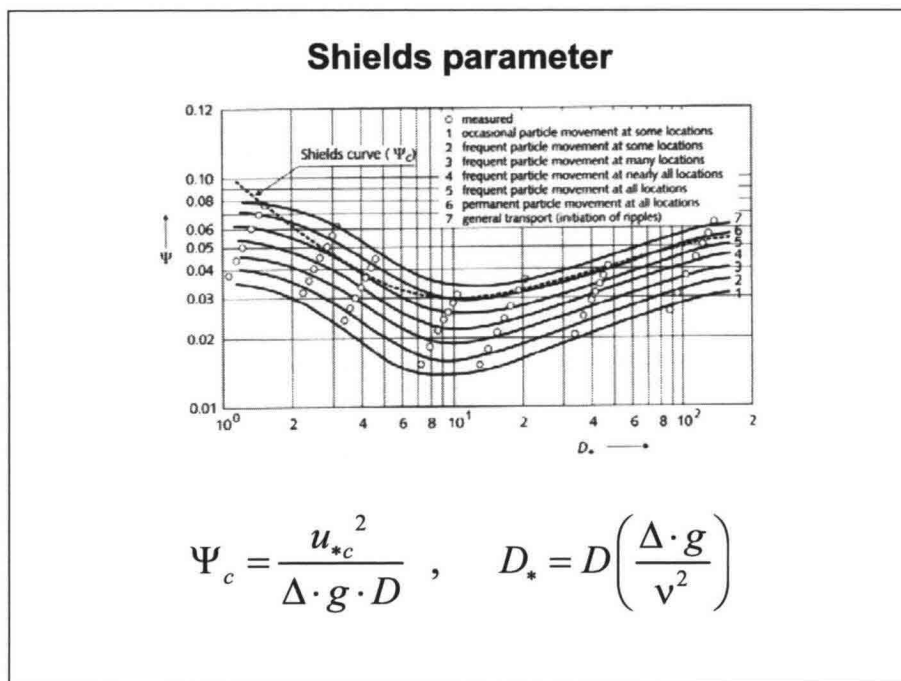

For further details see Appendix 1 to these notes.

7.3 Wave attack (wind waves, ship's waves & associated return currents)

See attached excerpts of Manual for the use of rock in Hydraulic Engineering. Wind wave attack and waves generated by ships can be of major consequence. The impact of wave loads caused by ships can be derived from the loads caused by wind waves. Waves are relevant for the upper part of a slope protection and for overtopping of levees/

For further details see Appendix 2 to these notes.

7.4 Protective materials

7.4.1 Riprap / rock / boulders

Key question: what is available at reasonable cost?

Reference to Jamuna Bridge project in Bangladesh (local rock, but also imported from India, Indonesia and Bhutan)

Important aspects:

- Soundness
- Shape
- Mass density
- Size & gradation

Size and grading

Table 3.3 Fine grading classes

Standard fine gradings designated by size

Grading class designation (mm)	Class limit definition <i>D</i> (mm)							
	30/60 mm		40/100 mm		50/150 mm		80/200 mm	
sieve opening size (mm)	Cumulative mass passing sieve as percentage of total mass							
	min.	max.	min.	max.	min.	max.	min.	max.
250	--	--	--	--	--	--	95	100
180	--	--	--	--	90	100	50	100
125	--	--	90	100	--	--	10	50
90	--	--	--	--	10	50	--	--
63	90	100	10	50	--	--	0	10
45	30	70	--	--	0	10	--	--
31.5	0	20	0	10	--	--	--	--
22.4	0	10	--	--	--	--	--	--

Size and grading

Table 3.4 Light grading class requirements (The 10-60 and 60-300 kg classes are equivalent to the 200/350 and 350/650 mm classes respectively. W_{50} is the average mass of the stones exclusive the stones ("fragments") < ELCL)

Standard light gradings designated by mass						
Grading class designation (kg)	Class limit definition W (kg)				Effective mean mass, W_{50} (kg)	
	Extreme Lower (ELCL) $y < 2\%$	Lower (LCL) $0\% < y < 10\%$	Upper (UCL) $70\% < y < 100\%$	Extreme Upper (EUCL) $97\% < y$	min.	max.
5- 40	1,5	5	40	80	10	20
10- 60	2	10	60	120	20	35
40-200	5	40	200	300	80	120
60-300	30	60	300	450	130	190

Standard light gradings designated by size and average mass									
Grading class designation (mm)	Class limit definition by Square Hole (mm)			Average mass retained on B ; W_s (kg)					
	% by mass passing			Rock density, ρ (t/m ³)					
	EB hole < 2	B hole 0 - 10	ET hole 97 - 100	< 2,5		2,5 - 2,9		> 2,9	
	min.	max.	min.	max.	min.	max.	min.	max.	
200/350 mm	100	200	350	20	40	25	45	25	50
350/650 mm	200	350	650	115	180	130	200	145	240

Size and grading

Table 3.5 Heavy grading class requirements

Standard heavy gradings designated by weight						
Grading class designation (tonnes)	Class limit definition W_s (tonnes)				Effective mean mass, W_{50} (tonnes)	
	Extreme Lower (ELCL) $y < 2\%$	Lower (LCL) $0\% < y < 10\%$	Upper (UCL) $70\% < y < 100\%$	Extreme Upper (EUCL) $97\% < y$	min.	max.
0,3 - 1	0,2	0,3	1	1,5	0,54	0,69
1 - 3	0,65	1	3	4,5	1,7	2,1
3 - 6	2	3	6	9	4,2	4,8
6 - 10	4,0	6	10	15	7,5	8,5

7.4.2 Concrete materials

- Placed at random
- Pitched/ special shapes
- Fixed to geotextile
- Connected by steel cables

7.4.3 Asphaltic materials

- Asphaltic concrete (closed)
- Sand asphalt
- Open stone asphalt (open)

7.4.4 Geotextiles

- Woven geotextile
- Non-woven geotextile
- Thermally bonded
- Needle punched

- Composite
- Stitching of woven and non-woven
- Needle punching

7.4.5 Special materials

- Gabions
- Colloidal concrete
- Geo-containers
- Mixed solutions

7.5 Slope stability – general, earthquake, seepage

7.5.1 Slope stability – static, quasi static

- Slip-circle calculations (Bishop, etc.)
Only information on safety against sliding, no information on deformation
- Finite element methods
Also information on deformation

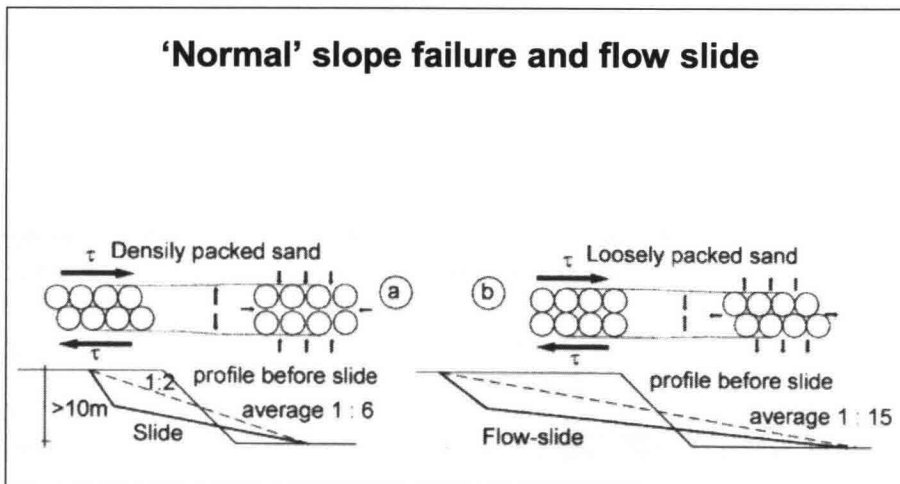

Flow slide at a result of activities elsewhere

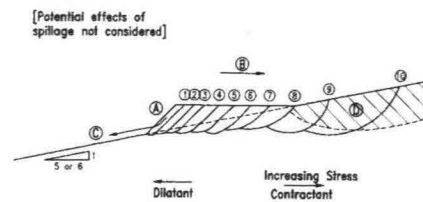

- Ⓐ Oversteep face left on or adjacent to temporary slope after dredging
- Ⓑ Regression of oversteep face by 'ravelling' of face - failure in very thin slices (relatively slow process)
- Ⓒ Removal of falling material as density current down 1 in 5 (or 6) slope
- Ⓓ Zone of looser material in slope with potential for flow sliding
- Ⓔ Local failures into or undercutting loose zone and serving as trigger for flow

Extra horizontal acceleration (reducing the safety factor) – can be taken care of in slip-circle and finite element analysis

Generation of excess pore-pressure, which cannot dissipate quickly enough; may lead to liquefaction of sub-soil and loss of stability

7.5.2 Factors that may affect slope stability

- Static/ pseudo static
- Slope stability analysis
- Seepage
- Flow slides (liquefaction)
- Dynamic (earthquake)
- Extra forces
- Cyclic loading that can cause liquefaction
- Drainage/ densification
- Drying out – reduced weight

7.6 Filters

- Granular
- Geometrically open/ closed
- Filter fabrics
- Strength
- Sand tightness
- Water permeability
- Durability

Geometrically open and closed filters

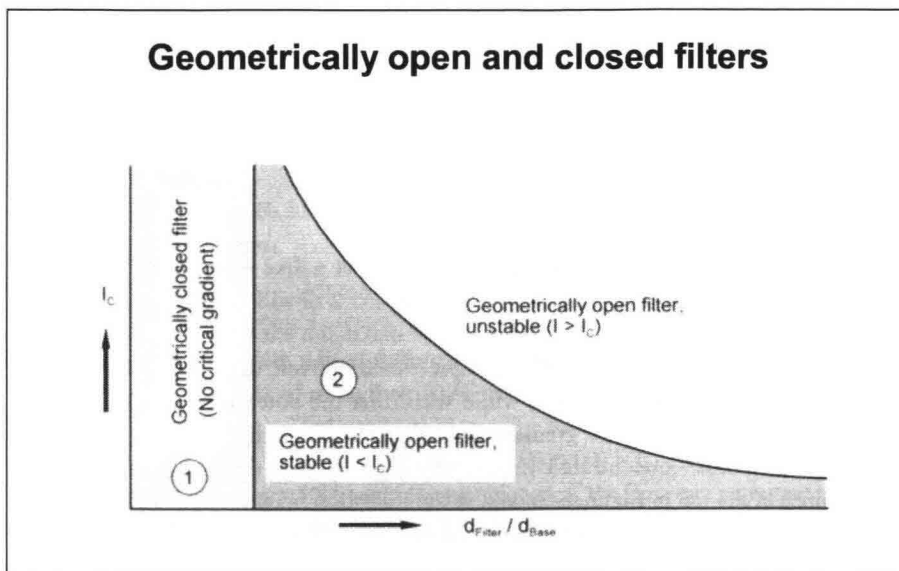

Geometrically closed filters

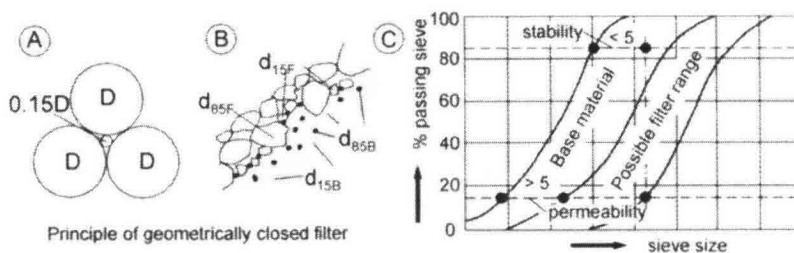

$$\text{Stability: } \frac{d_{15F}}{d_{85B}} < 5; \quad \text{Internal stability: } \frac{d_{60}}{d_{10}} < 10; \quad \text{Permeability: } \frac{d_{15F}}{d_{15B}} > 5$$

7.6.1 Filter fabrics

- Strength
- Sand tightness
- Water permeability
- Durability

7.7 Design of river training structures – interactive process

- Functional requirements
- Location and accessibility of the site / works

- Total scope / size of the works
- Shapes of structures
- Type of slope protection to be applied
- Sub-soil conditions
- Working conditions during construction
- Type of equipment available or required
- Availability of materials
- Experience of (local) contractors
- Contracting rules
- Maintenance

8 More aspects of flood protection

8.1 Flood protection with dikes/ levees

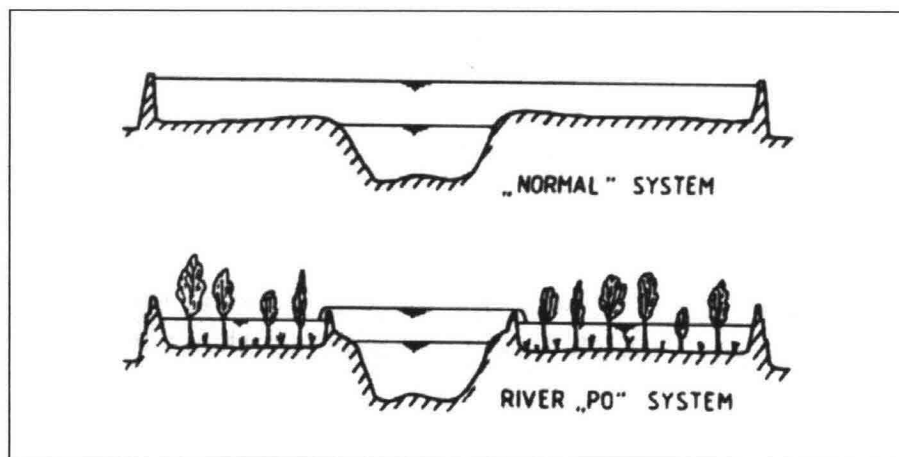

8.2 Flood protection with storage reservoirs/ retention

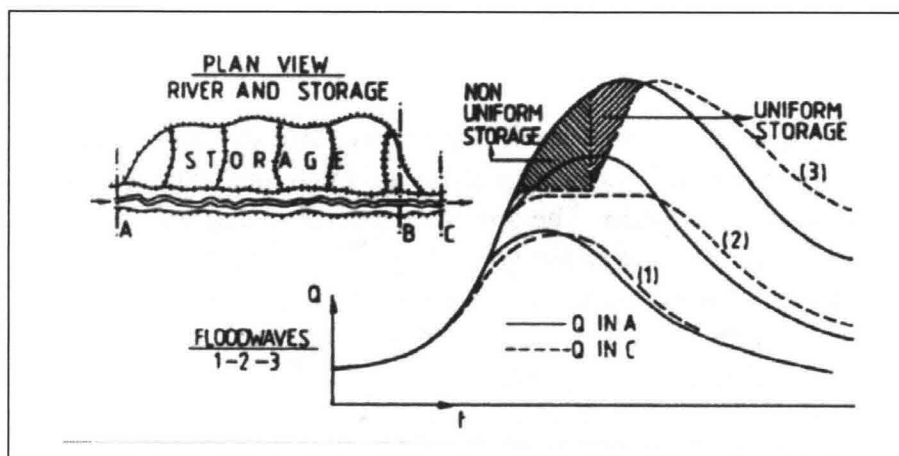

8.3 Spreading of discharge (flood protection and navigation)

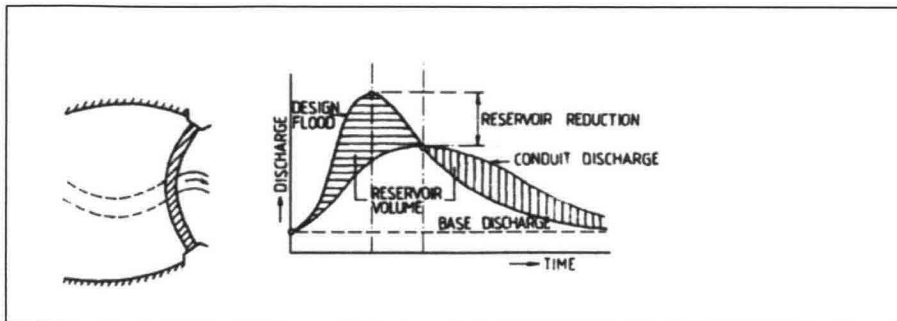

Examples

Reference is made to the sheets in the Power Point presentation (periods 4 and 5)

- Lower Rhine
- Maaswerken, The Netherlands
- Lower Guayas Project

8.4 Design aspects of levees/ dikes

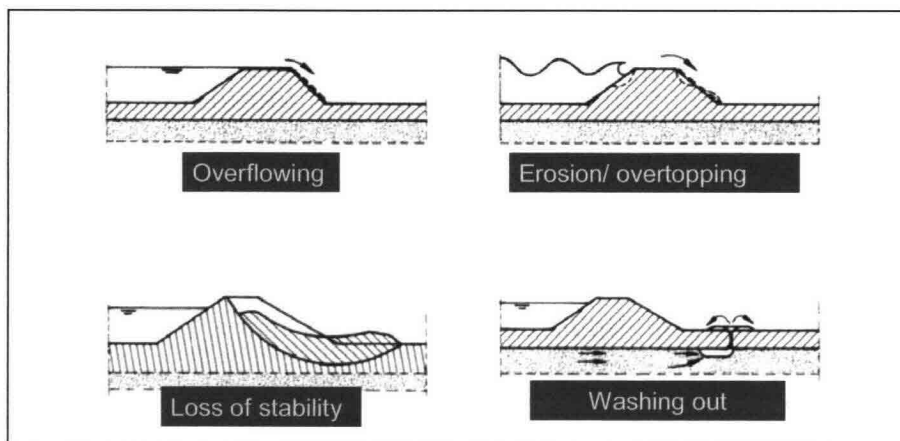

9 Closing subjects

- On increasing discharge
- Nature and environment
- Climate change and consequences for river discharge

PART 2 - RIVER TRAINING STRUCTURES

Lecture notes UNESCO – IHE Institute for Water Education – Course 2003 - 2004

Lecture notes prepared by G. te Slaa, based on Chapter 8 from CUR Manual no. 169
(Manual on the use of Rock in Hydraulic Engineering)
Originally prepared by J. van Duivendijk and reviewed by G. te Slaa

Provisional issue – regular issue will be prepared by UNESCO – IHE

Date: 2 February 2004

CONTENTS

Page

1	INTRODUCTION	1
1.1	Context of topics to be discussed in these notes	1
1.2	Types of inland waterway structures and functions	1
1.3	Design process	2
2	RIVER TRAINING STRUCTURES	4
2.1	Types of river training structures and functions	4
2.1.1	Flood protection	5
2.1.2	Navigation	5
2.1.3	Bank protection and longitudinal dikes	6
2.2	Data Collection, river surveys and studies, model testing	8
2.2.1	Example of data collection for a major river training project	10
2.2.2	Example of model testing for a major river training project	12
2.3	Plan layout and overall concept selection	15
2.3.1	General	15
2.3.2	Spur-dikes	17
2.3.3	Longitudinal dikes or guide banks (guide bunds)	20
2.3.4	Bank Protection	24
2.4	General considerations for cross-section design	27
2.4.1	Functional requirements and non-technical boundary conditions	27
2.4.2	Hydraulic and geotechnical boundary conditions, including scour	29
2.4.3	Materials availability	35
2.4.4	Materials supply	35
2.4.5	Construction considerations	36
2.4.6	Maintenance considerations	37
2.5	Structure-specific design aspects	37
2.5.1	Design of the revetment of river training structures	37
2.5.2	Geometrical design of river training structures	38
2.5.3	Stability of the toe of revetments	40
2.5.4	Determination of hydraulic and other loads	42
2.5.5	Sectioning of slope and revetment	45
2.5.6	Selection of revetment system	46
2.5.7	Dimensioning of revetment	46
2.5.8	Transitions	49
2.5.9	Example of the structural design of the cover layer	50
3	BED PROTECTION, REVETMENT AND LINING IN NAVIGATION AND WATER CONVEYANCE CANALS	53
3.1	Differences between rivers and canals	53
3.2	Types of structures, functions of canals and structures	53
3.2.1	Navigation canals	54
3.2.2	Water conveyance canals	54
3.3	Plan layout and overall concept selection	55
3.4	General considerations for cross-sectional design	57
3.4.1	General	57
3.4.2	Design parameters for slope/bed protection as a function of overall canal design	57

3.4.3	Physical boundary conditions	57
3.4.4	Materials availability and supply	58
3.4.5	Construction considerations	58
3.4.6	Maintenance considerations	59
3.4.7	Requirements to be fulfilled by the revetment layer	59
3.5	Structure-specific design aspects	59
3.6	Example design of slope protection in navigation canal	62
3.6.1	Background and data	62
3.6.2	Determination of cover layer on slopes	62
4	SPECIAL STRUCTURES	63
4.1	General	63

1 INTRODUCTION

1.1 Context of topics to be discussed in these notes

Rivers and canals, which can collectively be referred to as:

Inland waterways, in general flowing through an environment of easily erodible material requiring protection against water motion and other forces.

Undesired erosion can be prevented by either a structural cover layer or a vegetative protection, depending on the intensity of loading.

In principle any inland structure in and along rivers, navigation canals or water conveyance canals (for irrigation, water supply or hydropower generation) will be discussed. Most of them include rock, but other materials can also be used. The rapid growth of shipping on inland waterways between 1945 and the 1970's and the consequential need for infrastructural improvements has stimulated large-scale research programmes together with the development of new materials, design methods and construction techniques.

Apart from shipping, the development of irrigation and hydropower in many countries has led to river basin development in a multi-purpose context. Such river-basin development, inter alia, implies full or partial regulation of the river flow, which in turn requires the construction of river training works.

Finally, the ever growing population and related traffic density result in the need for crossing many rivers by bridges. In many cases these bridges can only be built when river training works are carried out.

Along with these technical developments there has been an increasing general awareness of the social, environmental and economic aspects of civil engineering projects, so much so that it is now often necessary to consider these factors at the initial design stage.

1.2 Types of inland waterway structures and functions

Multi-purpose river basin development always in one way or another requires the execution of river training works. An extensive description of river training works is subsequently, but this can be briefly summarized by pointing at their possible functions: flood protection, maintenance or improvement of navigability, and to control/prevent bank erosion and/or outflanking of a bridge or weir.

In this respect it is, however, fair to state that river basin development not only requires river training to be carried out but also flood regulation by means of dams and reservoirs and flood embankments to prevent flooding. Bed protection is often an integral part of these works, to prevent or at least to reduce the consequences of scour in the direct vicinity of the works.

Where *flood protection* is basically a high water problem (accommodation of a flood wave within prescribed river cross-sections), *navigability* is typically a low water problem

(providing of sufficient water depth during part of the year). To *prevent erosion* of existing bank lines, bank protections and longitudinal guidance of the river flow are applied. Main objective of *flow guidance*, particularly in braiding rivers, is to keep the higher -eroding- velocities at sufficient distance from the (projected) banks or other structures.

1.3 Design process

The design stage offers the best opportunity to influence the complete scheme for engineering interventions. Particular attention is drawn to the following aspects:

(a) Functional analysis

Structures along or in rivers are mainly built to meet requirements with respect to:

- protection of a certain bank line or slope
- prevention of outflanking
- fixation of river channel, guidance of flow
- recreation
- ecology
- ferry landing (jetty)
- river-side road

In most cases, decisions have to be made whether protection is required and if so where and when.

(b) Data and boundary conditions

Required hydraulic data mainly concern river discharges, associated water levels and river morphology. For wide rivers, also wave action may have to be considered. Besides, local scour at the envisaged structure is often most determining for the design of the structures concerned in these notes.

(c) Other boundary conditions, acceptance

Typical aspects which may be important for acceptance by authorities (river-, agricultural, navigational), financing agencies or the general public:

- adequate measures to limit or nullify negative effects of the scheme on existing structures, e.g. ferry landings (jetties), drain outlets
- social acceptability, e.g. use of local skills
- acceptability from the (recreational) shipping point of view, e.g. vertical sheet piling reflects waves causing problems for small craft

(d) Finance, benefit / cost

Possible requirements have to be defined in terms of Benefit/Cost. Typical possibilities for optimisation concern the depth and width of a channel, height of a river bank, length and/or depth of a bed protection and choice of type and size of materials.

(e) Construction

The type of equipment must be considered with respect to:

- maximum load on roads (e.g. of the order of 1 or rather 10 tonnes)
- maximum draught and anchoring requirements
- land-based/waterborne construction possible

Construction techniques must also be evaluated with regard to preliminary judgements of accessibility, duration of construction work and materials supply in relation to seasonal constraints (flood season). A prerequisite of a good design is that it can be implemented (i.e. constructed). As with all construction projects, it should be made possible to carry out the work in a methodological and economical manner. Also the time factor must be considered: critical construction stages must be completed within a period of favourable working conditions (river discharge, water levels, current velocities, ice).

(f) Management and maintenance

The management of the works after completion must be considered. Assumptions made at the design stage must be realistic and achievable during the lifetime of the scheme. Some typical considerations may concern for instance:

- zoning, if it was part of the design considerations, must be adhered to
- vandalism (i.e. removal of revetment elements) must be kept under control
- staff must be able to inspect (monitoring) and report about damage
- any sailing speed restrictions must be reasonable

A proper balance of costs of inspection and maintenance and the capital costs of the scheme is desirable. To achieve this an inspection and maintenance plan is necessary. This should be available at the design stage so that the design can be adjusted to suit the inspection and maintenance procedure or vice-versa. For instance, if inspection and maintenance is not possible once construction has finished, then the design must have a sufficiently low probability of failure.

In order to develop an inspection and maintenance plan, it is necessary to consider the ways inland waterway structures may fail. In respect of structures along rivers vandalism and theft may be mentioned, which may imply removal of cover layer elements. Acceptance of these various failures may be set dependent on the possibilities of repair and maintenance comparing to the rate of failure (rapid or more gradual).

(g) Environmental assessment and legal aspects

Effects of the structures on the environment of the river and its adjacent banks should be assessed. Water levels, current velocities and river morphology are most likely environmental characteristics to be effected, while also effects on bank vegetation, fauna and landscape should be regarded. Legislation, regulations and local byelaws must be known or adapted as required.

(h) Detailed design

Once an overall pre-selection of possible design concepts has been made the proposals thus arrived at are followed up by a more detailed design. To do this it is first of all necessary to define more clearly the boundary conditions or constraints which apply to the scheme. These can be considered in terms of hydraulic, geotechnical and non-technical boundary conditions.

In an inland waterway environment the hydraulic boundary conditions are generally set by hydrology, river morphology and scour, waterway geometry and ship-induced water motions, producing loads on the bank revetment. The geotechnical boundary conditions are set by the type of subsoil and its characteristics of failure, such in relation to natural events like earthquakes and water level variations while also the availability of materials may impose constraints.

Within these boundary conditions, the designer can define a basic geometry of the structure and dimension the parts of the works including revetment, its cover layer and filter layer details together with the detailed design of transitions and edge zones. At the same time, other non-technical constraints, such as effects on the natural environment and compliance with social or economic factors are taken into. Also methods and means of construction and the expected maintenance are evaluated. This is done for each alternative solution and in a number of successive (iterative) steps.

2 RIVER TRAINING STRUCTURES

2.1 Types of river training structures and functions

The focus in these notes is on river training works carried out in the middle and lower reaches of rivers characterized by rather small gradients ($i < 10^{-3}$), current velocities (U) usually well below $U=5$ m/s and alluvial soils with grain sizes between $D=0.01$ mm and $D=20$ mm. Consequently, typical mountain stream engineering is not discussed.

River training, apart from various types of earth works, is basically achieved by the following structures:

- sills
- weirs
- spur-dikes (most of the time called groynes but this word is not used here to avoid confusion with groynes in marine structures)
- longitudinal dikes, depending on their function also called guide banks or guide bunds
- bank protection (revetments, hard points)

An intermediate type of structure may be indicated as river bed or submerged spur-dikes, in fact sills constructed in the river bed, to achieve control of the river cross-section in a vertical sense.

Sills and weirs will be treated in a future version of these notes.

A definition of **river training** can be as follows:

“all engineering works constructed in a river which are required to guide and confirm the flow to the river channel and to regulate the river bed configuration for effective and safe movement of floods and river sediment”.

River training works may have to be carried out for flood protection, to maintain a navigable channel, and last but not least to prevent bank erosion and/or outflanking of a bridge or weir.

River training works consist of *structures* and various types of *earth works*. The latter comprise levees, embankments, dredging and reclamation for channels and cut-offs and these will not be discussed in these notes. An overall description of these types of works can be found in Jansen (1979). The function(s) of the aforementioned *structures* can best be described on the basis of the three aims mentioned above: flood protection, navigation and bank protection.

2.1.1 Flood protection

Flood protection is basically a *high-water problem*: the flood wave travelling down the river requires space. This results in high water levels and consequential flooding of riparian lands. Flooding can be prevented or decreased by a number of measures, which in most cases need to be combined:

- *storage* of part of extreme flood waves in a reservoir, situated in the mountains or in the plain
- enlarged *discharge capacity* by cutting river bends, enlarging of wet cross-section by dredging or by creation of floodways and/or bypass channels
- construction of *dikes*

Various structures are required as part of a comprehensive flood protection scheme. In this respect are mentioned: reservoir dams, barrages sills and, last but not least, flood embankments (also called river dikes or levees).

Flood embankments along rivers in nearly all cases consist of earthworks without slope protection. Growth of vegetation on such banks is possible. Slope protection, however, can locally be required because of current or wave attack in which case one tends to speak of bank protection. There is however, a basic difference between the protection of the slope of a flood defence and that of a riverbank: Serious damage to the slope protection works of a flood defence may lead to a breach in the embankment and thus to inundation while damage to a bank protection normally does not have such far reaching consequences. A distinction must here be made between safety and economy. The *safety* of people and property behind a flood defence and damage due to flooding will normally result in a low frequency of failure being acceptable for the flood defence. This has an impact on the design of the (possible) slope protection, height of the embankment and permissible seepage. Such low frequency of failure is not required for a bank protection system. Here, damage is restricted to the protection itself which can be repaired and it is possible to determine cost and benefits (i.e. avoided damage) and design a bank protection which is an optimum from an economic point of view. The "Guide for the Design of River Dikes" (CUR Report 142, 1991) presents details on all structural aspects of river side embankments.

2.1.2 Navigation

If flood protection is characterized as a high-water problem, then navigation is typically a *low-water problem*. To satisfy navigation requirements a continuous river channel must be formed having a thalweg at a minimum specified depth, width and radius for all possible river discharges. Accordingly, measures taken aim at:

- availability of a least available *depth* (LAD) over a certain river reach most of the time
- availability of a minimum *width* for all river stages which provide the LAD
- limitation of maximum *currents*

In many cases in the past it was the magnitude of navigation reached after some time (i.e. more and larger ships) which prompted the need for such measures.

In a meandering river this regulation of the low-water bed can only be achieved by means of a system of bank protection works, spur- and longitudinal dikes (Figure 1).

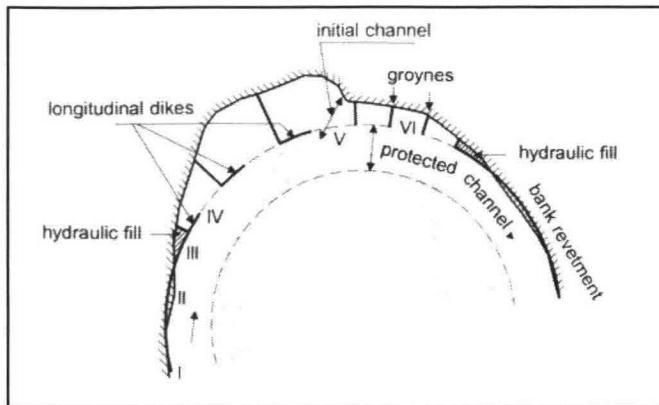

Figure 1 Types of channel fixation structures

In river engineering, a distinction is made between open and closed spur-dikes (Jansen, 1979, page 353). For this Manual only the closed structures are of discussed.

Spur-dikes, bank protection and longitudinal dikes to a certain extent all confine the river flow to its low-water bed. The latter two do this, however, in a gentle manner over some distance while spur-dikes have locally an abrupt and definite constriction effect.

If low-water bed regulation is contemplated for a braiding river, in many cases there is no other option than to close one or more channels in order to pass all low-water discharge through the navigable channel. Channels can be closed permanently by means of a closure dam but also partly by means of a weir. The weir acts as a stage regulating device and it will be overtopped permanently or only part of the time.

2.1.3 Bank protection and longitudinal dikes

The main functions of bank protection works and longitudinal dikes are:

- guidance of river flow
- prevention of erosion of existing bank line

Bank protection can have a direct or an indirect function.

One uses the word *direct* if a bank is protected against erosion by a revetment (Figure 1) or by a series of hard points. Such *bank protection* will normally be required if the existing bank line must be maintained because of economic or other human interests. This means in practice that bank protection will often be found along the water-front of river-side towns, at ferry terminals and at bridge abutments. The falling apron shown is a special type of a flexible toe structure.

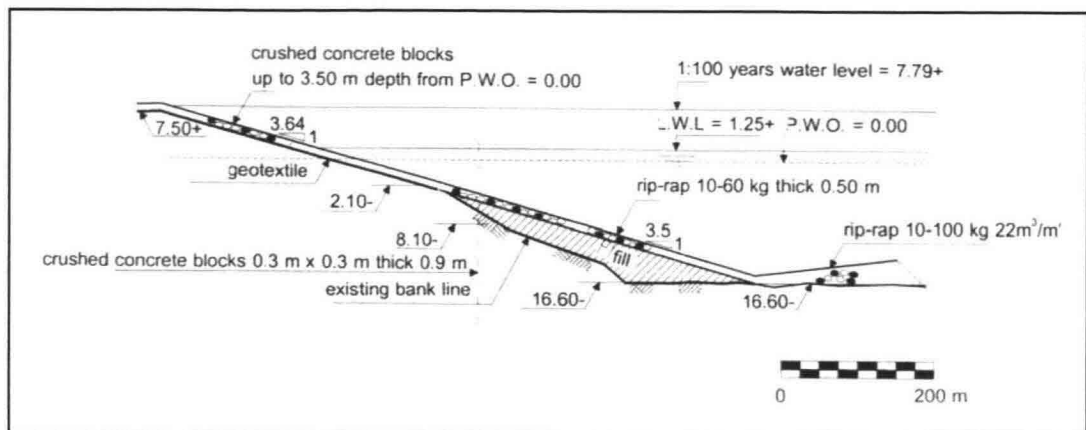

Figure 2 Revetment on existing river bank with falling apron

A *longitudinal dike* will have the function of a flow-guiding structure in meandering rivers, to achieve regulation of the low-water bed as part of a system of spur-dikes and longitudinal dikes. In that case it functions at the same time as bank protection as defined above.

Both, bank protection and longitudinal dikes, can, however, also have an *indirect* function in the sense that because of their ability to maintain the existing “bank line” a bridge (or a weir) is prevented from being outflanked by the river.

This problem of outflanking is not serious in those meandering rivers which, because of navigation requirements, have a fully controlled low-water channel thanks to a system of spur-dikes and longitudinal dikes. Outflanking, however, is a serious threat in large uncontrolled meandering rivers and in braiding rivers. In the latter, it is the rapid shifting of channels and their unpredictable pattern which cause the problem. The danger of outflanking can be largely overcome by a system of longitudinal dikes (here called guide banks or guide bunds) and major hard points which together prevent the shifting river channels from reaching and subsequently eroding the river side embankments upstream of the bridge, the approach embankments to the bridge and its abutments (**Error! Reference source not found.**).

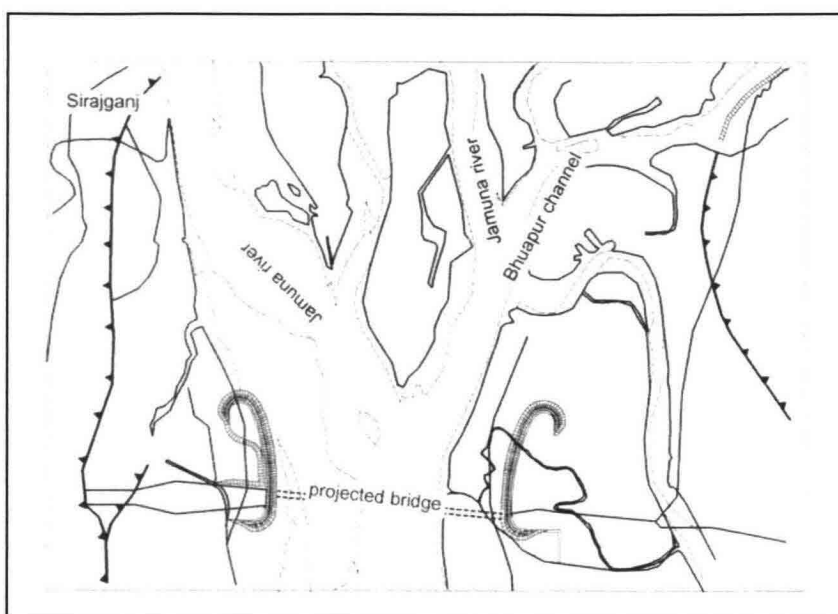

Figure 3 River training works for Jamuna Bridge, Bangladesh

Within the overall context of the aims mentioned so far in this Section, the following inland waterway structures are of interest:

- bed and bank protection works in rivers and canals
- lining of water conveyance channels
- river training works like spur-dikes, weirs, sills (e.g. entrance to bypass channels) and flow-guiding structures (longitudinal dikes or guide bunds)
- special structures like pipeline and cable crossings, fish sluices, anchoring structures, bridge piers and jetties

For protection against erosion, rock is used in these structures as a cover layer, as a filter or both.

In view of different boundary conditions, hydraulic loads and function of structures, a distinction will be made between:

- river training works, including bed and bank protection works
- bed protection, revetment and lining in navigation and water conveyance canals
- special structures as already listed above

2.2 Data Collection, river surveys and studies, model testing

If there is any conclusion that stems from a comparative study of river basins it is that no two are the same. Each river is distinctive in many natural characteristics like:

- shape, size and variation of stage and discharge hydrographs
- sediment load through the years and in relation to discharge and season
- area of drainage basin
- slope, width and depth of individual channels
- overall width of river and variation therein as a function of time and location
- density, angle of junction of tributaries and off-takes
- composition of sediment

- pattern of accretion and erosion, shifting of channels and bypassing or cutting off bends
- influence of tides (and salinity) in the lower branches

Not all of these characteristics are however of immediate interest to the designers of river training works.

Three types of rivers are often distinguished: straight, meandering and braided. Important parameters which determine the difference between these river types are:

- discharge
- bed gradient
- bed material
- sediment load

The type of river has important practical implications for both, the extent and layout of training works and for the construction depth of protection works. The latter is largely dictated by the scour assessment.

Various researchers have tried to derive relationships between the relevant parameters in order to define whether a river is straight, meandering or braiding. However, all these relationships are based on (in most cases) limited empirical data from a limited number of rivers. Especially the knowledge of the morphological processes in large braided rivers is still very limited and this has an impact on the (few) designs made so far for bank protection and river training works in these rivers. This situation is aggravated by the difficulties experienced when one tries to prepare and calibrate a scale model (with movable bed) of a braided river reach and, subsequently, wants to measure the effects of various types of river training works on currents, channel pattern and bed profiles.

Many of such rivers can be called “difficult” and “unknown”: **difficult** in this respect means uncontrolled or largely uncontrolled, with rapidly changing bank lines through erosion and sedimentation, fast changes in channel patterns and in local channel depth due to scour and silting up, all in relation to discharges, shape of hydrograph and sediment load; **unknown** signifies the lack of historic data on sediment transport and bank line shifting, the limited accuracy of discharge measurements and recorded water levels (the latter due to repeated re-positioning of gauges in the past). This does not inevitably imply that it is impossible or undesirable to design and construct river training works on even the most difficult and unknown rivers. It should, however, be emphasized that in such cases an extensive measurement campaign (river surveys, aerial and satellite photography) hydrologic and morphological studies as well as model testing using various types of hydraulic scale and mathematical modelling is required to collect necessary data.

In the following a summary is presented of data collection and analysis, studies and model testing carried out for the design of the river training works for the Jamuna Multipurpose Bridge in Bangladesh in the period 1987-1989. The works were carried out in the mid nineties. The construction cost of these river training works was in the order of US \$ 300 million. The aforementioned data collection, studies and model testing followed by detailed designs have cost US \$ 3 million and must be considered as a minimum in the given circumstances; i.e. a 15 to 25 km wide braiding river with an annual average peak discharge of 65,000 m³/s and an annual average sediment load of 730 million tonnes.

2.2.1 Example of data collection for a major river training project

To illustrate the scope and magnitude of data collection and model testing required for a major river training project a summary is presented of surveys and testing carried out during the period 1987-1989 for river training works for the Jamuna Bridge in Bangladesh across the river Brahmaputra (locally called Jamuna).

Data collection and river related studies were carried out regarding geomorphology, river morphology and hydrology. Figure 4 shows how colour photography can be a highly useful technique in analyzing the complex behaviour of rivers as the Brahmaputra River. Overall changes in the channel pattern can be detected as well as details such as bend erosion. The photographs are taken from Klaassen et al (1992).

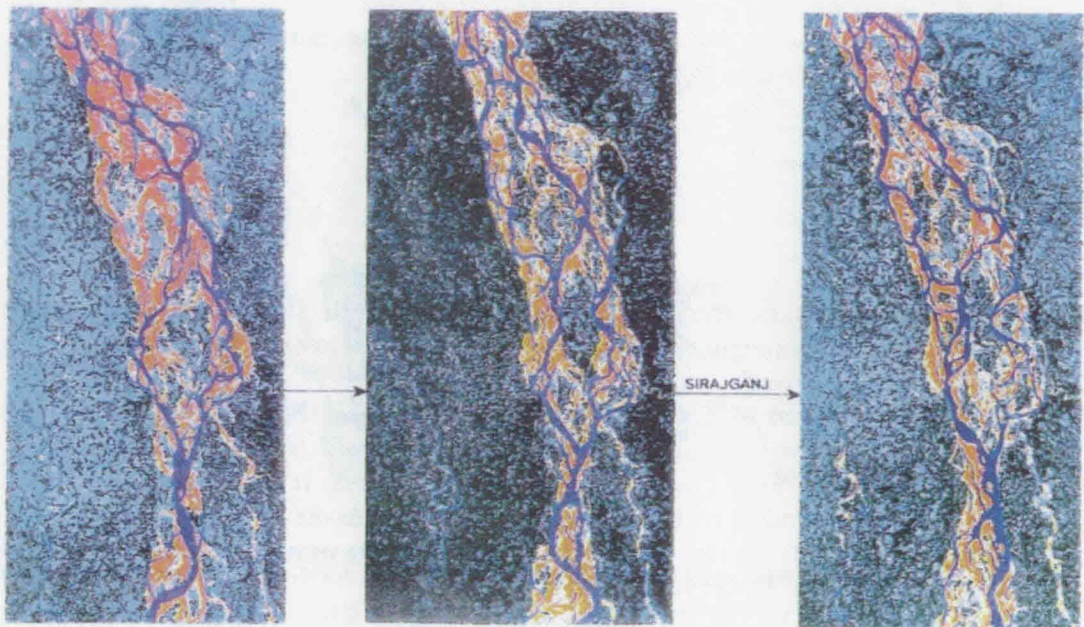

Figure 4 Evolution of the Brahmaputra River from 1978 to 1987 visualized using satellite colour imageries

Geomorphology

The Jamuna has a history of instability and is a young river in its present course. The probability that the river will stay in its present channel for the design lifetime of a bridge had therefore to be carefully examined. Two aspects of this needed consideration: the first is the mechanism of the change in course that took place between the years 1776 and 1830 and the second is examination of mechanisms for possible future change.

This geomorphological approach led to the conclusion that, although it is conceivable that tectonic processes may change the flow of the Jamuna, they are not likely to affect the course of the river. Changes on a scale large enough to affect the river's course would have a much wider implication for Bangladesh than the river stability at the bridge. The present course of the river is close to its optimum for the present hydrograph and there are no reasons to assume a major change during the lifetime of the bridge.

In addition to this geomorphologic study, a remote sensing study on the satellite CCT's was done. The analysis of the results was aimed towards an understanding of channel changes and bank erosion, and towards development of a method to predict these phenomena over the next years. Photographs showing the differences in channel characteristics and erosion patterns of successive years were compiled and results analyzed (**Error! Reference source not found.**). It was observed that, even over one year, substantial changes occur. Finally, computerized cross-sections of the Jamuna River as measured during the past years were analyzed to check a possible shift of the River in a westward direction. It was concluded that there is no significant shifting of the Jamuna River in either direction.

River Morphology

The technical study of river morphology was required to improve the understanding of various riverine processes in braiding rivers in general and in the Jamuna River in particular. In this respect, two main issues had a direct bearing on the design of the proposed project:

- stability of the Jamuna River in its present course and channel pattern
- maximum scour that may occur either at the river training works or at the bridge piers

Though some detailed studies of the Jamuna River have been made in the past these were in general not based on extensive surveys and measurements. This is understandable as

- data collection in developing countries does not always have a high priority and is usually carried out over a short period only as part of a study for a specific project
- data collection on a large braiding river like the Jamuna is particularly cumbersome, difficult and expensive

The consultants of the project collected and analyzed all available information on the subject during the first phase of the study. They concluded that only limited data was available on bed levels in the Jamuna River during flood conditions and that the hydrographic surveys to be undertaken as part of a second phase should concentrate on bed changes during the flood season.

Consequently, an elaborate programme of surveys and measurements aimed at deriving a better understanding of the various types of scour and bedform dimensions was carried out during the period July-November 1987, though for various reasons not all of the planned programme could be executed. Some significant conclusions are:

- plan form characteristics of the Jamuna River have remained essentially the same over the last 15 years. There is no evidence of an advancing alluvial fan that may change the conditions at Sirajganj (a town at 8 km north of the bridge axis) drastically over, say, the next 50 years
- general scour (i.e. lowering of the bed level, owing to changes and developments in the catchment area) will most probably not occur. This was deduced from large scale 1-D modelling which simulated water flow and morphological processes of 1,000 km of the Brahmaputra/Jamuna river from Dibrugarh (India) to the confluence with the Ganges in Bangladesh
- bend scour is expected to reach a level of -21,6 m (bed level, below PWD) during a 1:100 year flood
- following the surveys, confluence scour can now be predicted with sufficient accuracy. On average, the confluence total water depth can be as much as 25 m

- constriction scour, for a 1:100 year flood, with a bridge span of 4,600 m, has been estimated at 3.1 m
- a formula for the maximum height of sand waves on the bed of the Jamuna was established

Hydrology

Knowledge of the hydrology of the Jamuna River and its catchment is essential for the development of the design of the project. Parameters like river discharge and stages, flood frequencies and over-bank flow are functions in the determination of:

- the possible constriction (i.e. length of bridge) at the site of construction
- the level of bridge deck, of approach embankments and of areas for the bridge end facilities
- the impact of ships on bridge piers or superstructure
- the scour depths
- the size of units to be used for slope protection in river training works

Collection of hydrological data had already been extensive during the first phase of the study. Hence during the second phase, emphasis was placed on available computerized data, although additional data was also put into the project data base.

2.2.2 Example of model testing for a major river training project

For a tempting but technically extremely difficult undertaking like the design and construction of river training works for a bridge across the braided Jamuna (=Lower Brahmaputra) River, it is not possible to carry out some standard model investigations and thus to arrive at an answer to all questions regarding design criteria required. As however, the costs involved in the construction of the bridge and the training works are quite high, it is essential to optimize the technical solutions as much as possible. The funds available for the model investigations were, however, limited and this, in combination with the unusual problems to be solved, has resulted in a tailor-made approach to find answers for the questions posed. This approach has incorporated both mathematical and scale model investigations in combination with extensive field measurements.

In the next paragraphs, the modelling approach is outlined and it is indicated why this particular approach has been selected. Also the relation with the field measurements is indicated. The discussion addresses mainly the following points:

- description of the major design problems
- selection of models to be used
- input data for probabilistic design

Problems to be studied

In general terms, the purpose of the model investigations can be described as to arrive at an optimal solution for the river training works for the Jamuna Bridge.

More specifically the model investigations should assist in:

- determining the optimal layout of the river training works, including the number and type of structures required
- determining the required dimensions of the different elements of the river training works

- establishing the design criteria for those different elements, in particular the maximum scour (or rather, in terms of the probabilistic design approach taken here: the probability of exceedance of a certain scour depth) and the maximum water velocities
- to gain insight into bank erosion and channel changes of this braided river system

Selection of Models to be used

The selection of models to be used depends on the type of problem to be modelled and the accuracy required. The present problem is centred on bank erosion and scour in a braided river with fine bed material and floods having peaks of, on average, some 65,000 m³/s, in which major river training works have to be constructed. Following from the aforementioned problems, which have to be studied in this respect, important aspects of the simulation to be carried out will be:

- braided river pattern
- 2-D movable bed with rapid changes in channel pattern etc.
- dominant suspended load as mode of transport
- movable banks
- river system when subject to changes in (a) the catchment area like deforestation and/or (b) the lower boundary condition (rise of sea level)
- local scour near structures

The simulation of the above phenomena cannot be done in one model only. This is due to the general limitations of both mathematical models and scale models. Mathematical models and scale models do, however, also have their specific advantages: mathematical models do allow to study phenomena and long reaches of a river that can never be studied in scale models (like general scour); scale models can be used for phenomena that cannot be modelled mathematically at present (like 3-D flow phenomena, bank erosion and 2-D local scour). Accepting that not one model can be used to study all problems involved, a series of mathematical and scale models has been used in combination with field data.

Local scour

The local scour around structures can only be studied with a scale model. This scale model should be undistorted and preferably, the velocity should be scaled according to the Froude condition ($n_U = \sqrt{h_U} = \sqrt{h_L}$). The boundary conditions in this local scour model are:

- the depth (h) of the river in front of the structure
- the discharge (q , per unit width) in the river, both in magnitude and in direction

The first boundary condition was obtained from an analysis of prototype data. Within the framework of the study, an analysis was made of maximum depth in the Jamuna River and the result was used for the local scour model. The latter boundary condition, namely the discharge near the structure, was obtained from a mathematical model study of the 2-D depth-averaged flow field in the Jamuna River.

3-D flow and local scour

Because of scale effects and the complex 3-D effects, 3-D flow and local scour had to be studied in the local scour model. A rather important parameter in the flow field model is the bed roughness, because that parameter to a large extent determines the velocities

and the consequential scour process. The bed roughness was based on an analysis of field data.

River bed topography, including structures

Another important boundary condition for the flow field model is the topography of the river reach to be schematized. This bed topography was obtained from tests in a model with movable bed and banks. In this overall movable bed model the possible channel patterns near the river training works were studied as well as the effect of the river training works on the channel pattern and the impact of the channel pattern on the river training works. The most important criterion for this model was a fair reproduction of the braided channel pattern. To obtain a model that could simulate those channel patterns, serious scale effects in the simulation of other phenomena in the river had to be accepted. This is also the very reason why a mathematical flow field model was required "between" the movable bed/bank (scale) model and the local scour (scale) model: the flow field in the former model was seriously affected by those scale effects and could consequently not be used as boundary condition for the local scour model.

In the movable bed/bank model, the rate of the bank erosion process was also not reproduced on scale. In order to get more insight into this phenomenon, a study of field data was carried out. In particular satellite images were used, but also cross-sections measured by the Bangladesh Water Development Board were processed and analyzed as discussed above.

In the model with movable bed and river banks, also observations could be made as to the functioning of the proposed river training works, but due to scale effects the required length of the guide bunds could not be measured directly in this model. For that reason, an additional study was carried out. This study comprised -apart from an extensive literature survey and a visit to a number of hydraulic research institutes in India- the following elements:

- a mathematical model with a 2-D flow field model to study scale effects in the reproduction of the water movement in the movable-bed model
- an experimental study in a specially constructed tilting tray to study scale effects in the simulation of curved channels, and
- an analytical study of scale effects in the phenomenon of bypassing and cutting off in curved channels; This was done in combination with (i) a more detailed analysis of satellite images -showing these phenomena in prototype- and (ii) results of the overall movable bed model.

Finally, a mathematical model study was carried out for the 1-D morphological model. In combination with results of the local scour model, the results of the constriction scour model and field data, this allowed to determine the scour depth near the river training works.

Summarizing, in total 6 different model studies were carried out, notably:

- a 1-D mathematical model of the morphology of the Brahmaputra/Jamuna River
- a quantitative analysis of satellite images and river cross-sections
- an overall movable-bed scale model of a reach of the Jamuna River
- a mathematical model for the simulation of the 2-D flow field in the Jamuna River
- a scale model to determine the local scour around the guide bunds

- an additional study into the required lengths of the guide bunds, comprising a mathematical model investigation, an experimental study and an analytical study in combination with an analysis of satellite images

Input for probabilistic design

The Jamuna Bridge and the related river training works are being designed with probabilistic design methods. A consequence of using these methods is that it is not possible to define one single set of design criteria or a set of conditions that could be studied in the models discussed here.

The results of the models were analyzed to arrive at relationships that could be used during the probabilistic design. As an example, the local scour around the guide bunds can be cited. It was not enough to predict the local scour during the 1:100 years flood, but the local scour had to be related to the initial water depth near the guide bunds. The probability of occurrence of this local scour was then combined with the probability of occurrence of other stochastic variables like the channel's dimensions, the angle of attack and the discharge.

Local currents and eddies, observed in the model

During model investigations on possible channel patterns in the Jamuna bridge approach area, it was observed that an eddy occurred in the model. This was noticed when subjecting the head of the guide bund to a frontal flow attack. It was believed that in the model, this phenomenon of eddy development was exaggerated as a result of scale effects.

Stagnation of the flow at the head of the guide bund is responsible for eddy development in the flood plain between the guide bund and the flood. The flow will divert from the stagnation point either towards the main flow or in the opposite direction, to connect with the main flow, upstream of the stagnation point. The length, over which connection of the eddy and the main flow is possible, is restricted - this influences the size and the shape of the eddy in the flood plain. Also the resulting current velocities in the eddy are influenced by this restriction. Other influences are the alignment and layout of the embankments and configuration of the channels eroded during lower stages of the flood.

2.3 Plan layout and overall concept selection

2.3.1 General

Spur-dikes, longitudinal dikes and bank protection are all part of river engineering works. The layout of river engineering works and what can be achieved by it is very much dependent on the characteristics of a particular river. It is therefore not possible to provide rigid rules on what has to be done. An important aspect is the magnitude of the river training works in relation to the river regime. The larger the impact the more extensive the hydraulic response of the river will be. In this respect, the nature and origin of bank material as well as the processes affecting surface erosion of unprotected banks are shortly discussed. More overall discussions on bank protection and erosion control are given by Hemphill and Bramley (CIRIA, 1989) and by US-ACE (1981).

From both a geotechnical and geological viewpoint, it is convenient to classify river banks with regard to the type of soil of which they consist:

- **Cohesive** banks in which there is a significant amount of clay. Some peats can also be grouped under this heading
- **Non-cohesive** banks which have little or no cohesion, i.e. those with a small amount of clay, and generally comprising sand or gravel
- **Composite** banks which have a layered structure, e.g. a cohesive soil overlying a non-cohesive soil

Composite banks (see Figure 5) are most commonly found in rivers transporting bed material. Usually, the lower section of the bank mainly consists of sediment which is compatible with the bed material and represents an earlier bar deposit. On the upper bank sediment is found, which is not present in any quantity on the bed of the channel, since this results from the deposition of fine sediment on the bar surface during flood recession. Vegetation helps to stabilize the material and will encourage further deposition by increasing the local hydraulic roughness.

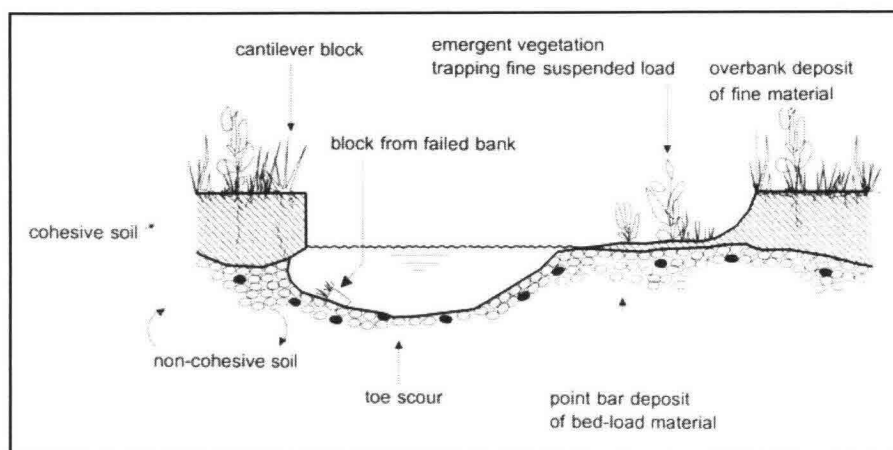

Figure 5 Composite banks having a layered structure showing a varying response to erosive forces

Rivers with sand or silt beds often have cohesive banks (including peat) which can be inter-bedded, especially if they flow through former glacial lake or marine deposits.

Unprotected channels in alluvial materials constantly adjust their overall shape and dimensions to the instantaneous flow regime through erosion and deposition. In fact, there is a permanent kind of instability and natural adjustment of a river towards a new flow regime. Nevertheless, some average state of the river may be defined, which is characterized by averaged values for discharge (Q) and water level (h). The construction of river training works may influence this average state called the *regime state* and thus lead to instability in unprotected parts of river bed and banks.

The main processes responsible for surface erosion are illustrated in Figure 6.

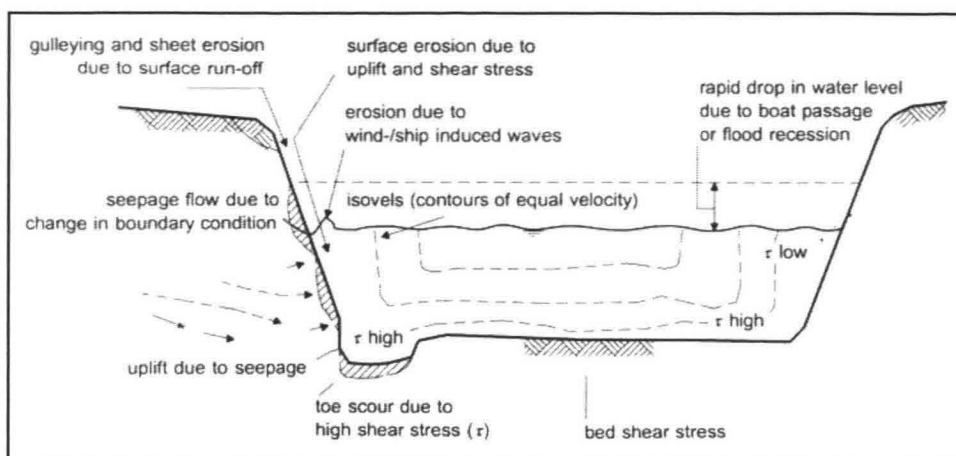

Figure 6 Channel cross-section illustrating surface erosion processes

Bearing in mind what has been said above, a few remarks will now be made regarding river engineering aspects related to the layout and overall concept selection of river training works. Following the nature of the works and their function a distinction will be made between:

- spur-dikes (or groynes)
- longitudinal dikes or guide banks
- bank protection (revetments and hard points)

2.3.2 Spur-dikes

Spur-dikes can serve one or more of the following purposes:

- rectification and fixation of the river channel in order to stabilize the low-water bed in a favourable position
- constriction of the low-water channel to provide a greater depth
- protection of the river bank by keeping the flow at sufficient distance or, in any case by reducing the near-bank velocities to less than 50% of their original value

It will depend on the nature of the river and the purpose(s) of the spur-dike whether only a few or a full system of spur-dikes has to be installed. Sometimes one or two spur-dikes suffice (Figure 7 -left), in other cases a system of spur-dikes is built in the outer bends of a river reach (Figure 7 - right). Finally, complete channel constriction may be required to fully satisfy navigation (Figure 8) and consequently a series of spur-dikes is installed along both sides of the meandering river.

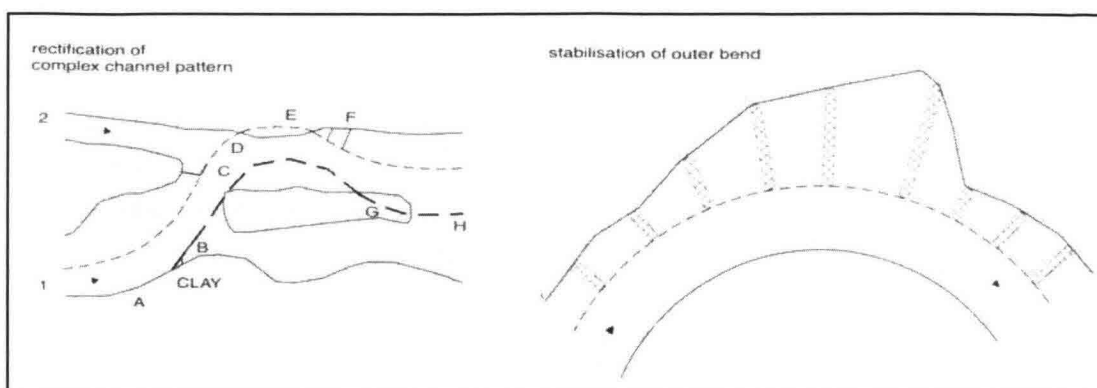

Figure 7 Spur-dikes built for various purposes

Though morphological aspects to a large extent determine what is possible in the particular circumstances, there are some simple rules which are valid in the case of a series of spur-dikes in a meandering river. One of these rules is the wish to have one strong and stable eddy between successive spur-dikes. This restricts the *spacing* (S_{SP}) between the spur-dikes, because the stability of one eddy is governed by the head loss ratio (e_{SP}) of the head loss in the river between two spurs and the velocity head ($U^2/2g$) of the river:

$$e_{SP} = (2g/C^2) (S_{SP}/h) \quad (1)$$

where C is the coefficient of Chezy and h is the water depth.

e_{SP} should never exceed unity and in fact, model investigations (Delft Hydraulics, 1973) have suggested that the following limit should be kept:

$$e_{SP} < 0.6 \quad (2)$$

In practice, a still lower limit is advisable (Jansen 1979) and in general, the distance between spur-dikes is given in relation to the constricted river width (B , see Figure 8). In the literature a maximum distance is mentioned of:

$$S_{SP}/B = 1 \text{ to } 2 \quad (3)$$

For *constricted* (meandering) rivers holds $S_{SP}/B = 0.5$ to 1 , which obviously is necessitated by navigational requirements rather than by eddy stability.

The larger the ratio S_{SP}/B , the stronger the accelerations and retardations of the current and the more the hindrance to shipping. This is also a cost problem: the larger the distance the smaller the number of spur-dikes but the stronger the local contraction and thus the scour at the heads of the spur-dike. A review of literature on the subject also reveals that suggested values for the ratio of spacing (S_{SP}) and *length* (L_{SP}) of spur-dikes vary between $S_{SP}/L_{SP} = 1$ and $S_{SP}/L_{SP} = 6$, the variation of which is apparently, inter alia, related to the radii of the curved channel and bank line, length of the curve and transition length between curves. The subject is presented in much greater detail by Jansen (1979) to which reference is made. As for their alignment, it is noted that some designers prefer spur-dikes pointing downstream in order to reduce current contraction.

Others prefer spur-dikes pointing upstream in order to reduce bank attack at overflow stages. It would appear, however, that nobody so far has been able to demonstrate what is the cheapest solution and, if so, whether such a solution is also applicable to other rivers. For the time being the shortest distance between head of spur-dike and bank line is recommended.

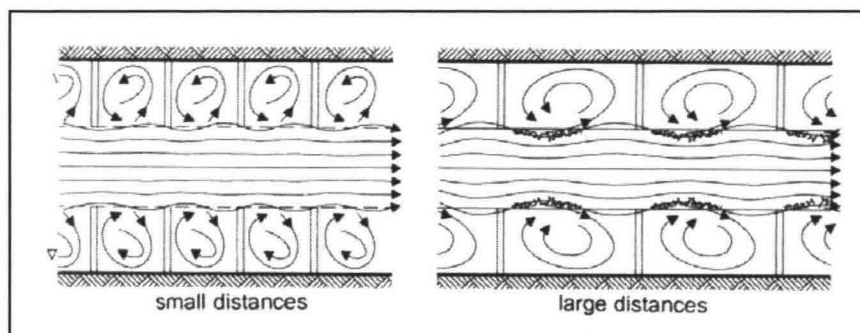

Figure 8 Distance between and length of spur-dikes in relation to river width

The above discussion mainly refers to spur-dikes placed in meandering rivers, for the purpose of channel rectification, fixation or constriction. The function, however, of spur-dikes in braiding rivers in most cases is merely to keep the flow away from the river bank or from a bridge abutment. It has in general not been demonstrated that spur-dikes in that case are a good solution. Because of the rapid shifting and unpredictable pattern of braiding river channels, scour will not only develop in front of the head of the spur-dike but can also develop along the "stem" of the spur-dikes. Moreover, this scour can attain great depths in braiding rivers which renders spur-dikes less attractive because of the required size, their deep toe level and the corresponding large area of revetment required.

For completeness' sake, vane-dikes and submerged or river-bed spur-dikes should be mentioned. Vane-dikes are low elevation structures designed to guide the flow away from an eroding bank line.

The structures can be constructed of rock or other erosion-resistant material, the tops of which are constructed below the normal water surface and would not connect to the high bank. Water would be free to pass over or around the structure with the main thread of flow directed away from the eroding bank. The structures will discourage high erosive velocities next to an unprotected bank line, encourage diversity of various channel depths, and protect an existing natural bank flora. Further details can be found in (US-ACE, 1981).

Submerged or river-bed spur-dikes are in fact low-crested sills, constructed in the river bed. They are connected to the river bank and near the bank as well as on a flood plain, the crest may be below the bed. These structures mainly have a navigation function, aiming at control of the river cross-section; in particular by maintaining a prescribed width of a navigation channel.

2.3.3 Longitudinal dikes or guide banks (guide bunds)

In a *meandering* river the choice between spur-dikes and longitudinal dikes is -more than anything else- mainly determined by the deviation between the plan form of the (desired) channel configuration and that of the bank line (Figure 9).

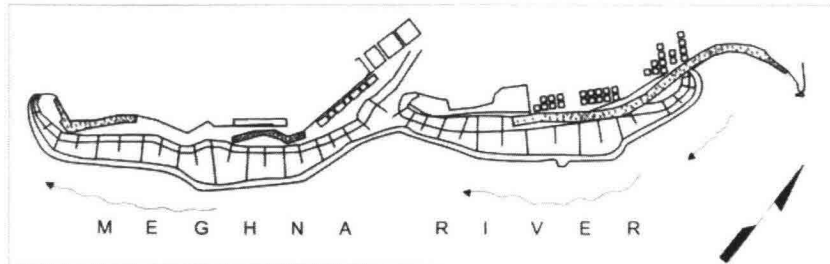

Figure 9 Bank protection in a meandering river: compromise between existing bankline and channel plan form

This situation is different for a *braiding* river where contraction of flow or abrupt changes in flow direction must be avoided to save in cost of river training works. Here, contraction and changes in flow direction both result in a greater scour depth which is the most important parameter in construction cost. In that situation the layout of longitudinal dikes (here called guide bunds) is governed by the wish to limit the scour which will develop after construction of the guide bund. This implies that guide bunds in braiding rivers will have a function as flow guiding structure (i.e. high-water channel rectification) but at the same time may produce the required constriction of the flow at bridge abutments and prevent outflanking of the bridge by shifting river channels capable to breach the approach embankments.

Current attack is the major direct loading on guide bunds. This loading is also essentially governed by the layout and consists of random attack of currents from any direction. Current attack can occur at any time on any part of the structure. Mainly three characteristic situations can be distinguished: oblique and frontal current attack and attack by outflanking channels (Figure 10).

- *Oblique attack* can occur at an extremely small angle or at a large angle. Such impacts are on the river face (Figure 10 a and b).
- *Frontal attack* is caused by (i) a parallel channel on the head of the guide bund and along the face of the structure (Figure 10 c) or (ii) by a deflecting attack by an outflanking channel (Figure 10 d).
- *Attack from curving outflanking channels* is caused by a channel which runs behind the guide bund and demonstrates the characteristic “ear” which progresses towards the approach embankment. Figure 10 e shows a small diameter and Figure 10 f a larger diameter of channel curvature associated with such currents.

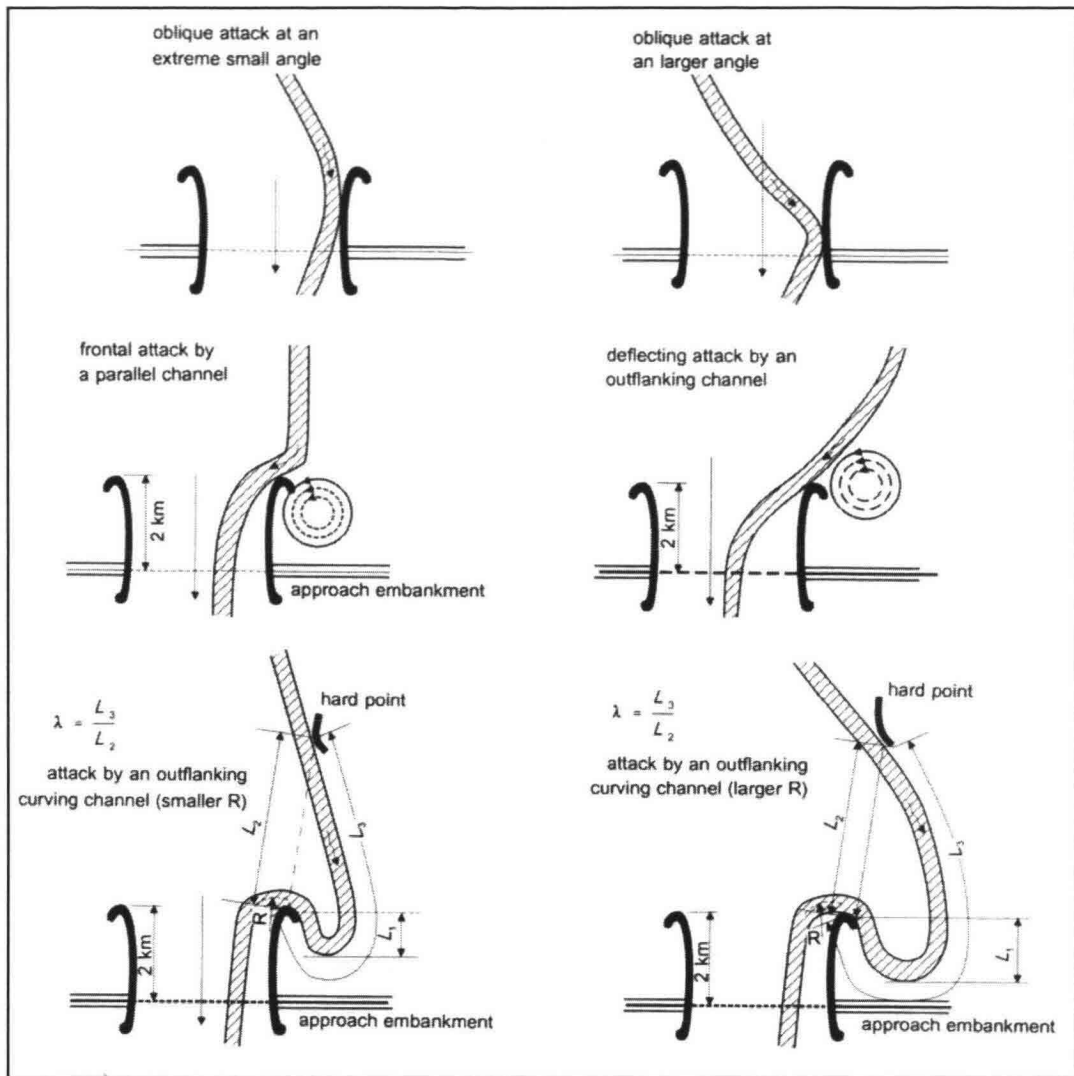

Figure 10 Current attack on guide bunds`

The layout of a system of guide bunds was determined for the bridge crossing, with a length of 5 km, of the braiding Jamuna River in Bangladesh. The impact of the functions, either control of channel configuration or guidance of flow, on the shape of a guide bank/bund is mainly twofold:

- A longitudinal dike or guide bank constructed for *channel configuration* will have a low submersible crest like a spur-dike; it will not necessarily be continuous; it will be only a few metres high and be applied in meandering rivers. Also “cross-dikes” (Mamak 1958) and “tie-backs” (USA-ACE, 1981) if applied will be low. Such connections between guide bank and river bank will be applied to prevent erosion during high flow stages and to encourage sedimentation between guide bank and river bank during the low-water period. In Figure 11 and Figure 12 such cross dikes and tie-backs are shown for two completely different surroundings:
 - Figure 11 (Poland) with emphasis on application of brushwood, sand fill with limited use of rock and built by manual labour
 - Figure 12 (USA) with emphasis on the use of rock

- A guide bund constructed for *guidance of flow* will have a crest high enough to prevent overflow. Because of this high crest and possible scour depths adjacent to the structure, guide bunds may attain a considerable height of 20 to 30 m. It is therefore preferably built as a bank protection rather than as trapezoidal-shaped bund.

Because of its function (guidance and diversion of river flow) these structures always connected to the high river bank or flood embankment by means of a non-submersible embankment.

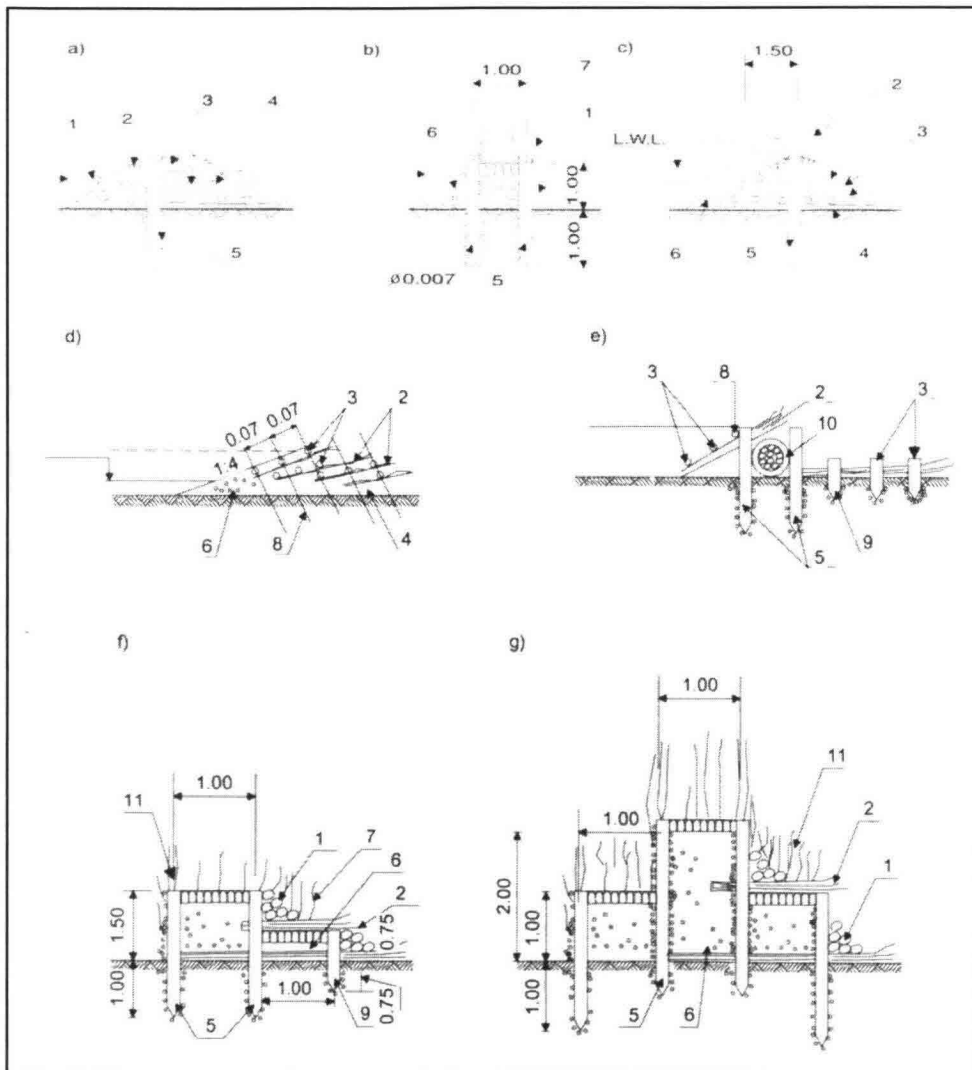

Figure 11 Cross dikes as applied in Poland with emphasis on limited use of rock

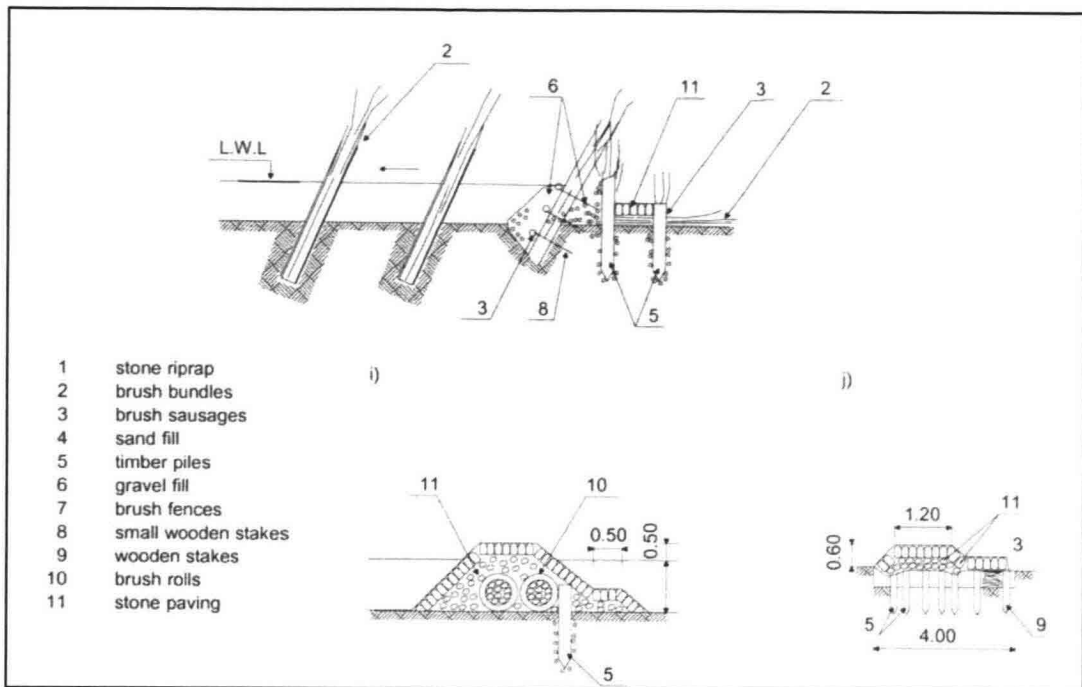

Figure 11 (continued) Cross dikes as applied in Poland with emphasis on limited use of rock

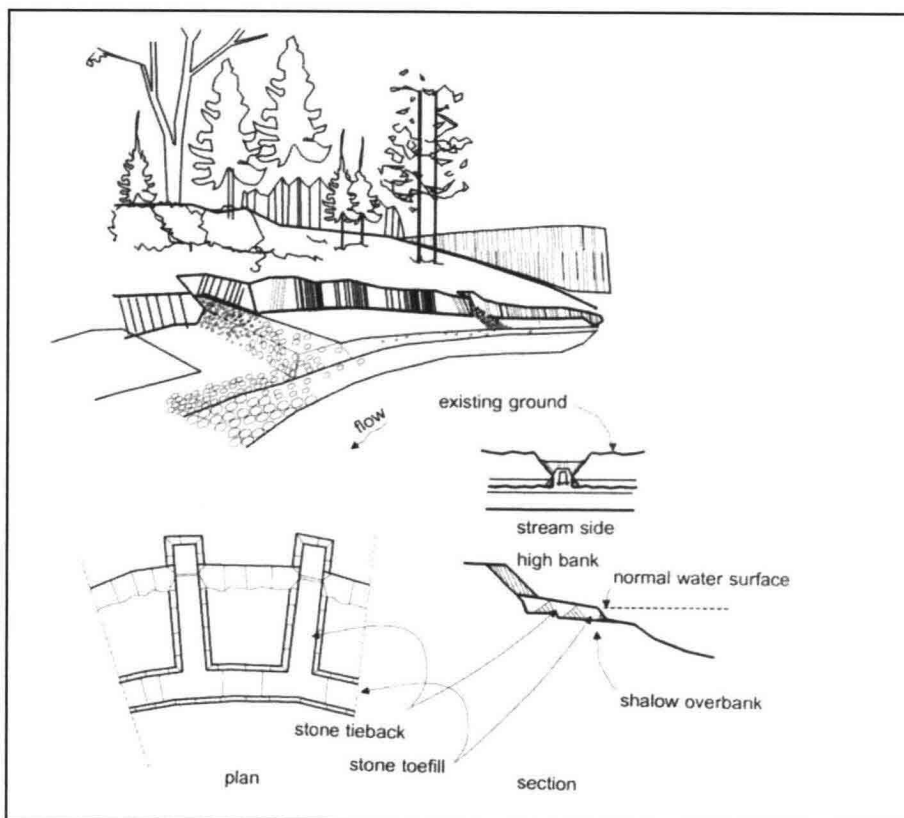

Figure 12 Cross dikes in USA with emphasis on the use of rock

2.3.4 Bank Protection

Normally, the layout of bank protection works is to a great extent determined by two factors:

- the unprotected natural bank line created by the river
- the desire to keep the banks intact, as they exist at the time of design/construction of the protection works, including the built-up area behind it

Unless bank protection works are meant to protect a reclaimed area which definitely protrudes into an existing river channel, the impact on the river profile and regime is negligible. In fact, a bank protection following the existing bank line is not more than a stabilisation of the existing situation. This can be achieved either by a continuous revetment or by a series of hard points. Hard points are normally applied along relatively steep banks when slight erosion between the hard points is acceptable, a continuous revetment is considered to be too costly and a spur-dike is physically impossible. Such a situation is demonstrated in Figure 13 and in Figure 14 showing hard points constructed in the USA and Morocco respectively.

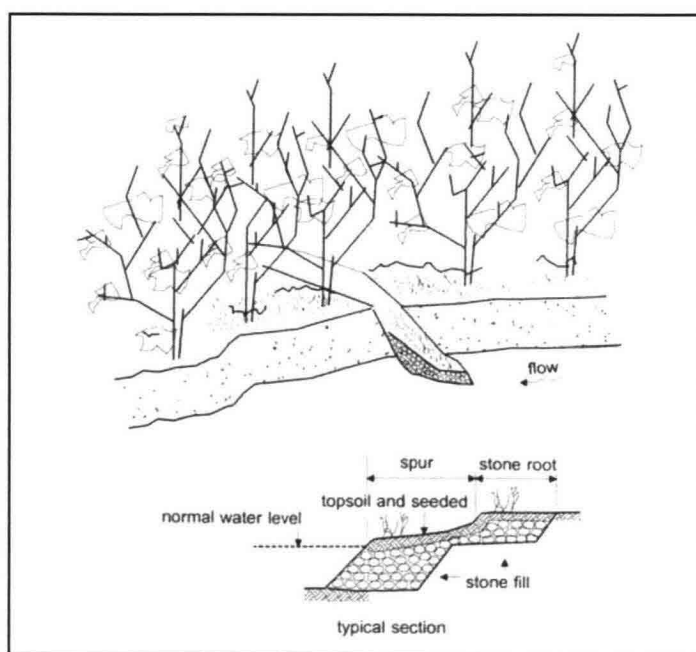

Figure 13 Example of application of a hard point in USA

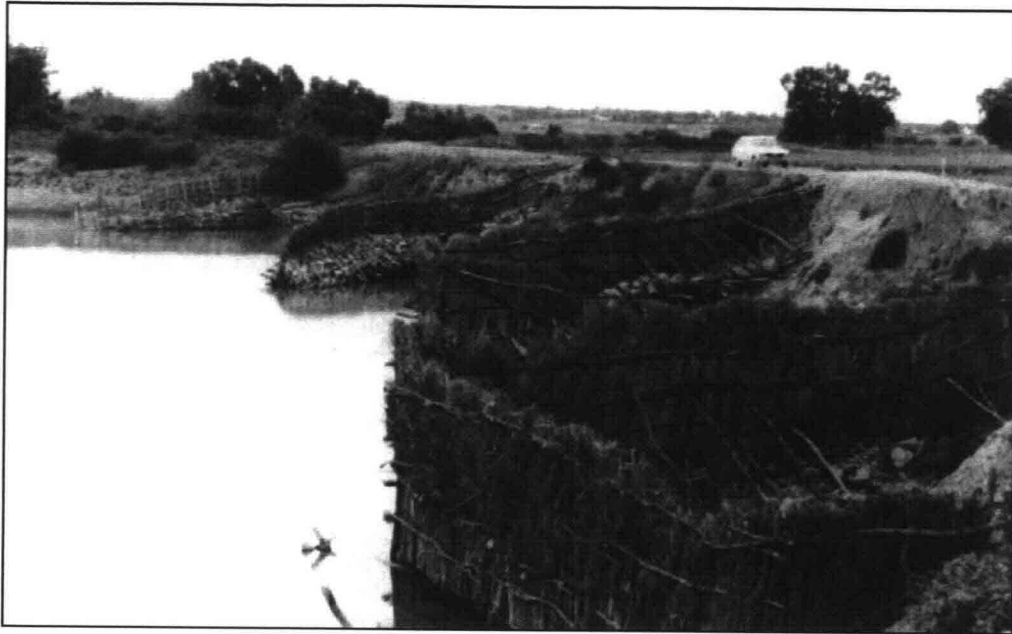

Figure 14 Example of application of hard points in Morocco (courtesy J. Van Duivendijk)

The expression hard point is however nowadays also used for major local bank protection works along braiding rivers (such as the rivers Brahmaputra and Lower Meghna in Bangladesh). Such hard points are built along the braid belt at regular distances and are meant to prevent regular bank line shifting (up to 500 m per year) by braiding river channels. At the same time relatively small (say up to 100 m) bank line shifting in between (called embayment) will be allowed. The functions of hard points and spur-dikes differ as well as the plan layout:

- Spur-dikes are applied in relatively shallow rivers in order to maintain a narrow deep channel for all possible discharges; they are relatively long in relation to the distances in between and the overall river width at bank full stage;
- Hard points are in fact not more than local revetments protruding somewhat into the river and which preclude local erosion and limit the erosion in between to an acceptable degree.

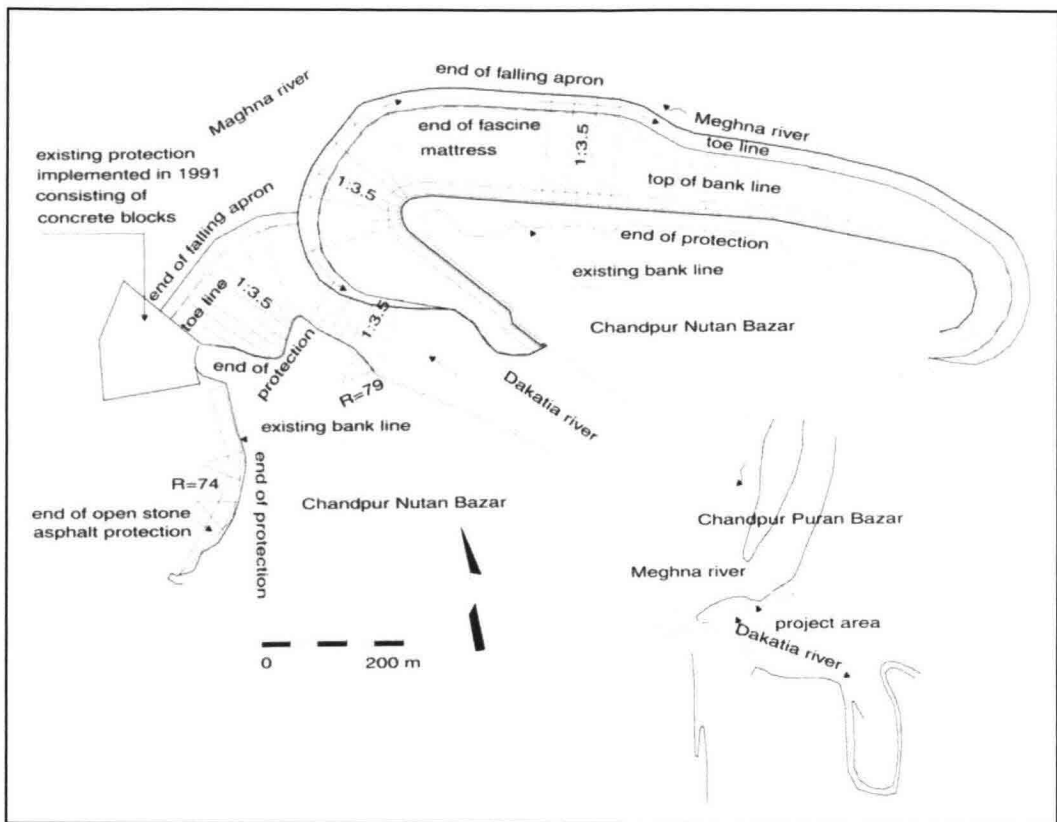

Figure 15 Major hard point on a braiding river

The relatively smooth new bank line resulting after construction of a continuous bank protection can have an impact on local scour depths while, after construction, shifting river channels will now meet an obstruction which *may* stop their movement. “May” is used here deliberately to warn designers not to fall into the trap of constructing a bank protection which has a foundation at shallow depth and is set at some distance from the shifting river channel precisely in order to have the toe of the bank protection at a high level and thus save costs.

2.4 General considerations for cross-section design

Definition of a cross-section is an important step in the design of a structure. This step of the geometrical design is discussed in the following Sub-Sections, which are addressing considerations like:

- functional requirements (technical and non-technical)
- hydraulic and geotechnical boundary conditions
- materials availability
- materials supply
- construction
- maintenance

2.4.1 Functional requirements and non-technical boundary conditions

From the foregoing it can be concluded that -as far as the cross-section is concerned- there are no principal differences between the three types of river training structures discussed (i.e. spur-dikes, longitudinal dikes and bank protection). In Figure 16, typical cross-sections are shown for the three river training structures mentioned. Though in principle it is possible to have another structural design than shown (e.g. sheet-pile spur-dike), in many cases nowadays river training structures consist of an earth body or slope, covered by a thin protection layer of which stones are a major component. Therefore, from now on no rigid distinction will be made in this Section between the said types of structures when the general considerations for cross-section design are reviewed.

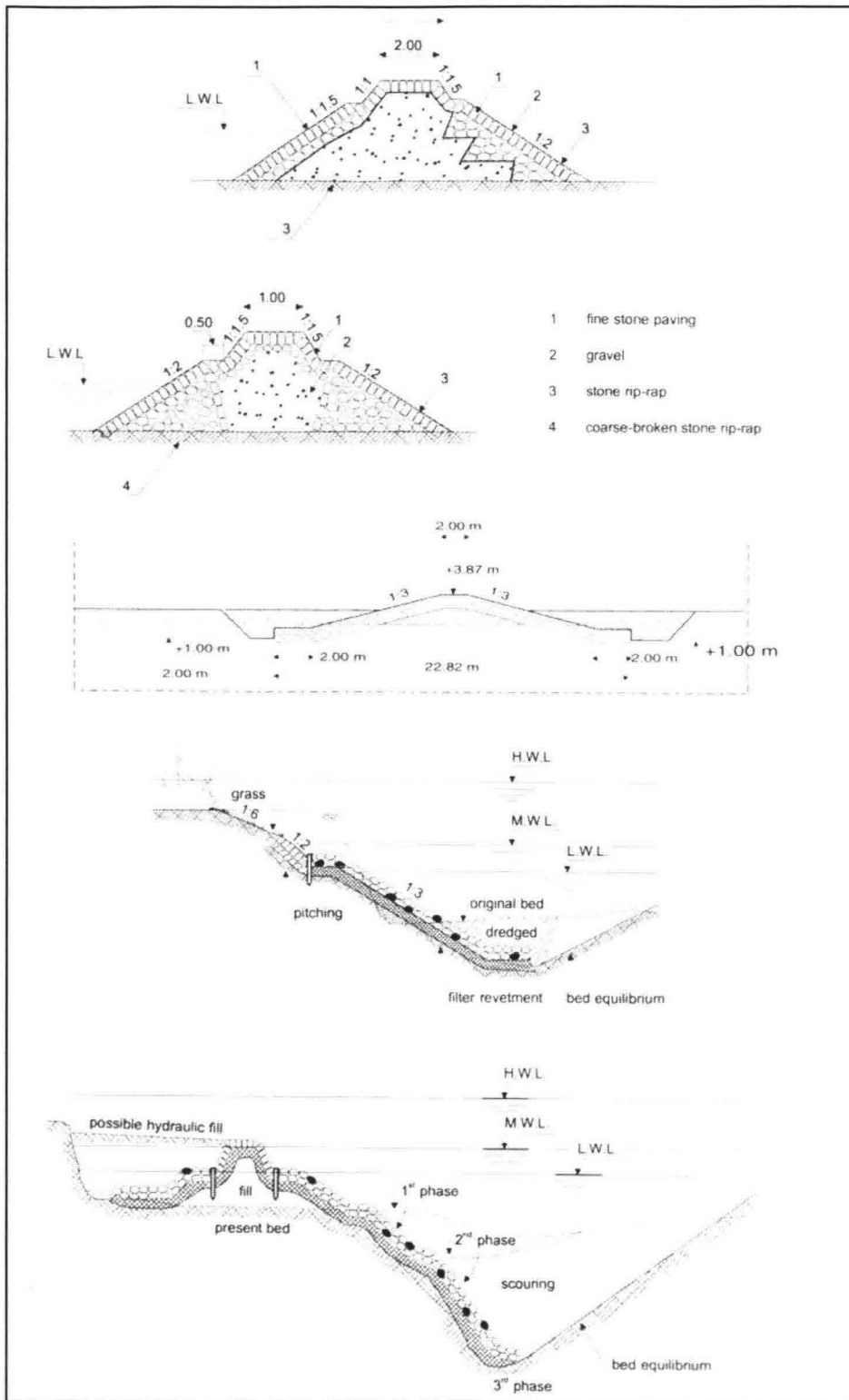

Figure 16 Typical cross-section of river training structures

Materials availability and supply, construction considerations, including local experience of comparable construction aspects, and maintenance are typical aspects of design implementation and are discussed hereafter.

Sometimes (the transition to) existing neighbouring structures at a particular site may impose severe geometrical constraints on (the cross-section of) the river training structure, but the flexibility of materials used will normally not prevent the design of a suitable solution. Particularly when carrying out rehabilitation of existing bank protection systems, it is often cost-effective not only to protect the old structure but also to incorporate it into the overall concept.

In this Section, some of the factors mentioned above as to restrain the selection of type of structure will be discussed. General functional and secondary functional requirements may have been determined on the basis of local conditions, standards or special wishes. A few examples may suffice:

- accessibility of spur-dikes for recreational purposes (mooring of pleasure craft, swimming) which rules out the use of rip-rap or other sharp-edged materials
- the crest level of slope protections in a river-side town has to meet the requirement to keep the foundation level of river side buildings free of flooding;
- desire to create a crest for the bank protection works which is sufficiently wide to enable positioning of a river-side road for two-way traffic in front of buildings
- desire to use the less attractive (stability/little interlocking) local river boulders for slope protection rather than more suitable angular stone which has to be imported;
- environmental requirements, for instance a “green” revetment for ecological and/or amenity reasons

2.4.2 Hydraulic and geotechnical boundary conditions, including scour

(a) Scour

Perhaps the most important aspect to be considered is the (various types of) scour to be expected in front of the structure during construction and after completion. This remark may appear to be superfluous but it is a fact that most failures of river training structures are due to a too optimistic view on scour development at the time of design and construction. Joint occurrence of (local) scour and critical morphological conditions (discussed below) may not be disregarded. To account for scour and morphological changes, in principle -and depending on the method of construction, the designer has two options for the toe depth of an envisaged structure:

- a toe constructed sufficiently deep, reaching to the anticipated maximum scour level
- a toe above the maximum anticipated scour level, but with a flexible toe protection of fascine mattresses
- as above but applying a *falling apron* instead of a flexible mattress

Scour and the consequent problems with geotechnical stability are not only important for the structure as a whole, but in particular for the design of the revetment toe. The design procedure required is given in section 2.5.3.

(b) Hydraulic boundary conditions, including morphology

The situation in rivers presents a more complicated problem than in canals. River mechanics have a large influence on the revetment boundary conditions due to, for instance, sediment transport, downstream channel migration and continuously changing channel cross-section. Hydraulic conditions discussed below are:

- river morphology
- hydrology and flow regulation
- waves

- currents
- water level changes due to tides and wind
- navigation, ship-induced currents and waves

(i) River morphology

River morphology, together with local scour, mainly determines the construction depths of structures. The geometry of alluvial river channels differs from that of an excavated channel. Various aspects of river mechanics must be considered when designing a revetment and these include:

- sediment transport
- long-term degradation and aggradation (due to changes in boundary conditions and/or upstream river works)
- downstream channel migration
- channel cross-section (changes due to variations in sediment transport and flow rate)
- location of existing revetment or other forms of river training works

In Figure 17 two bends are shown of a typical river channel with revetments located on the outer slope of each bend. The thalweg, the curve connecting the deepest points in subsequent cross-sections, also indicates the approximate position of the line of maximum flow velocity. The thalweg can vary significantly, especially in large rivers and must be investigated when trying to establish the channel geometry. An example of how the channel cross-section is affected by changes in flow is shown in sections A-A and B-B. Section A-A shows how the geometry of a cross-section taken between bends changes with discharge. Typically the cross-section will fill during high water and scour during low-water, although there is also a possibility of scour at high water downstream of the bend as shown. It may occur that the bed of large river systems -mean discharges of 10,000 m³/s or more- is raised (sedimentation) or deepens (erosion) several metres during a single flood. In smaller rivers, the scour and fill may only be a metre or less but, regardless of its magnitude, must be considered. Section B-B is taken on the bend and shows how the river scours at high water and fills during low-water.

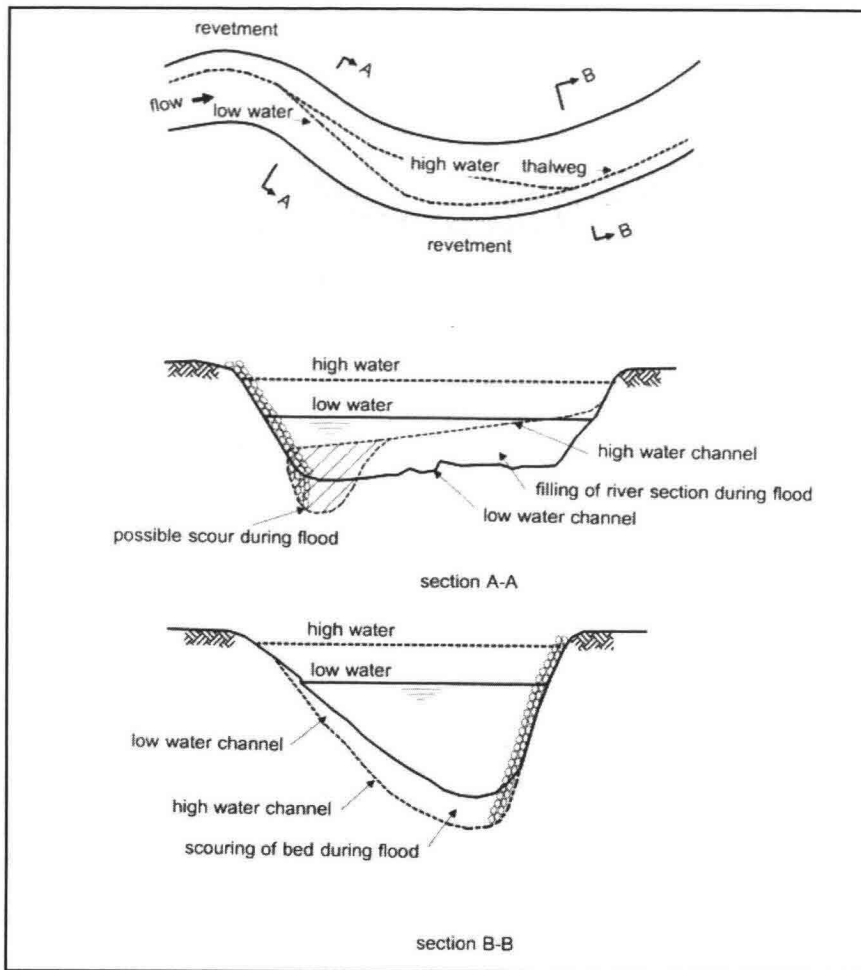

Figure 17 Changing river morphology

It is imperative that the designer is aware of the morphology of the river system on which the river training works are to be built.

(ii) Hydrology and flow regulation

The hydrology of a particular river basin (precipitation, surface run-off, flood-wave propagation) determines local water levels, their fluctuation or range during the season (seasonal floods) as well as during the day (flash floods) and discharge-related local current velocities. The principal consequences of river hydrology to the cross-sectional design of a structure are concerning the crest, berm and toe levels.

The natural hydrology can have changed considerably (or may change considerably in future) as a consequence of flow regulation (reservoir operation) or implementation of major river training works upstream. In this respect, also economic developments upstream and the consequential use of land surface (deforestation, pavements, drainage) can not be disregarded. This in turn has an impact on current velocities and on seasonal and daily range of water levels. The designer must keep this in mind when determining design values for current velocities and water levels.

(iii) Waves

Generally speaking, most rivers are too small and/or too shallow to enable the wind to generate high waves. However, on some wide rivers and estuaries, wind-induced waves can be critical. The factors affecting these waves are wind speed, direction and duration, fetch length and the water depth. Usually, the waves can be schematized as being of the "deep-water" type. When considering wind speed it is important to realize that wind action must be sustained to generate waves. Brief gusts reaching high velocities do not last long enough to cause wave growth. Consequences for the cross-section mainly concern the crest height (wave run-up).

(iv) Currents

Currents are either determined -directly- by the main flow in the river or -indirectly- driven by the main flow or caused by river training works (e.g. eddies). Structure-induced currents, mainly of a local character, may have implications to river and flood-plain morphology. The consequences, in view of the design of structures, of the need to control or reduce these currents mainly concern applicable slope angles and crest heights. Of course, the currents as such may determine the stone size to be used.

Examples of structure-induced currents are eddies.

Local currents of any of the above type may attack river training structures and may change with time, for instance due to a migrating channel. Implications of different types of current attack for the plan layout have been discussed in section 2.3.3, but may be relevant here as well.

(v) Tide and wind induced water levels and currents

In the tidal region daily fluctuations in water levels and currents along the revetment will take place in addition to the variations noted under (ii).

In some instances, the wind may cause a shear force on the water setting up a current. For steady-state conditions the current may reach a magnitude of 2 to 5% of the wind speed, whereas the effect on the water levels (wind set-up) can usually be neglected.

(vi) Navigation, ship-induced currents and waves

Major consequences of navigation for the cross-sectional design concern crest levels, slope angles and the extent of bed protection works. On river systems the techniques of navigation vary considerably from those in a canal. Ship-induced hydraulic loadings acting on an inland waterway are: return current, water level depression and front, stern and secondary (or interference) waves.

As shown in Figure 18, an upbound vessel will typically navigate in that portion of the channel with the least stream velocity, to save fuel and increase speed. In contrast, a vessel heading downstream will navigate in the maximum streamflow. The designer must take into account local practices and regulations to establish the effect on channel and bank stability.

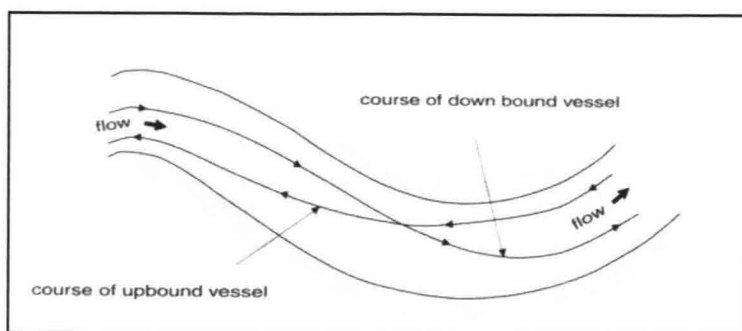

Figure 18 Example of navigation courses

Table 1 indicates typical values for a number of hydraulic loads. These figures should not be used for design purposes.

Table 1 Typical values of hydraulic loads

Situation	Return current (U_r) or natural current m/s	Water level Depression		Secondary waves		Wind waves	
		height h (m)	period T (s)	height H_i (m)	period T (s)	height H (m)	Period T (s)
small rivers and restricted navigation channels	1.0-2.0*	0.5-0.75	20-60	0.5	2-5	0.5	2
large navigation channels	2.0	1.0	20-60	1.0	2-5	1.0	3-4
large rivers & estuaries	3.0-4.0	1.0	20-60	1.0	2-5	1.5-2.0	5-6

^{*)} natural currents in steep upper reaches of rivers can be as much as 4 m/s.

c) Geotechnical boundary conditions

In general, restrictions with respect to slope angle are the most common consequences of given geotechnical conditions. Depth and slope angle of local scour holes at the toe, in this respect, are important design boundary conditions for possible overall sliding and sliding of the toe (see under scour above). In addition, the bank protection as such can play a role. The objective of providing bank protection is to prevent the hydraulic load due to water motion from inducing a geotechnical failure mechanism in the bank soil, by reducing the hydraulic load acting on the soil and thus possibly helping to stabilize the soil.

Failure mechanisms which may occur in a waterway bank are discussed in other courses. Here only some remarks are made on investigation and classification of the subsoil. Examples of failure mechanisms are illustrated in **Error! Reference source not found.**

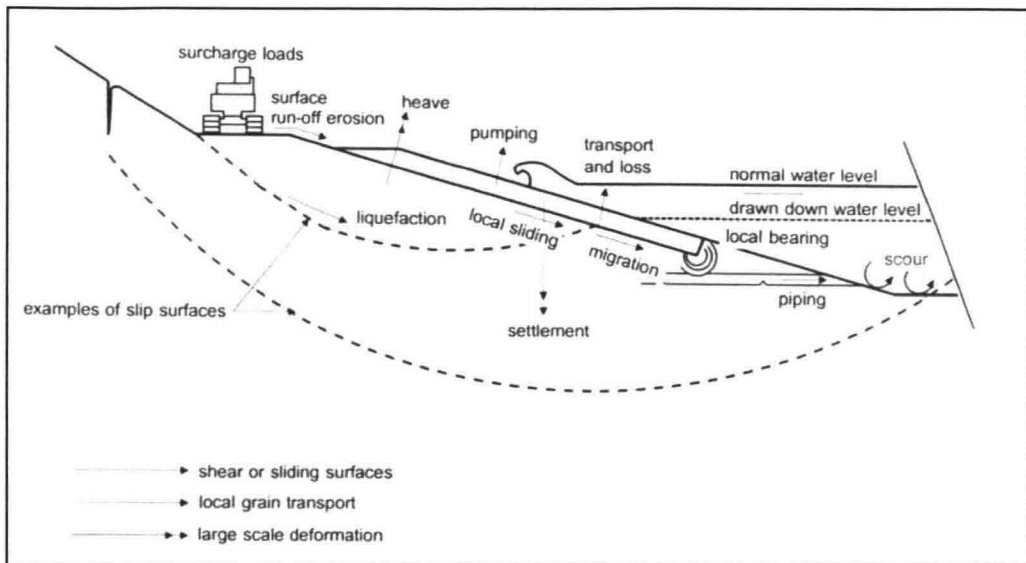

Figure 19 River bank subsoil failure mechanisms

Bank stability must be considered in terms of *overall stability* (the bank as a whole, including subsoil) and local or *macro-stability* (elements of the revetment or bank structure). In this respect, it should be noted that: a) local stability problems may ultimately lead to failure of the bank as a whole and b) both are often initiated by excessive scour development or erosion. The possible effects on bank erosion by hydraulic gradient forces or by rainfall run-off above the water line (*micro-stability*) have to be evaluated. For the final design of the revetment (both local or macro-stability and micro-stability, have to be evaluated as well. In Figure 20 the various failure mechanisms are classified. Many of the local stability failure mechanisms can be overcome by good construction methods: proper compaction of the subsoil and a sound geometrical design can considerably reduce the risks of piping, migration and liquefaction.

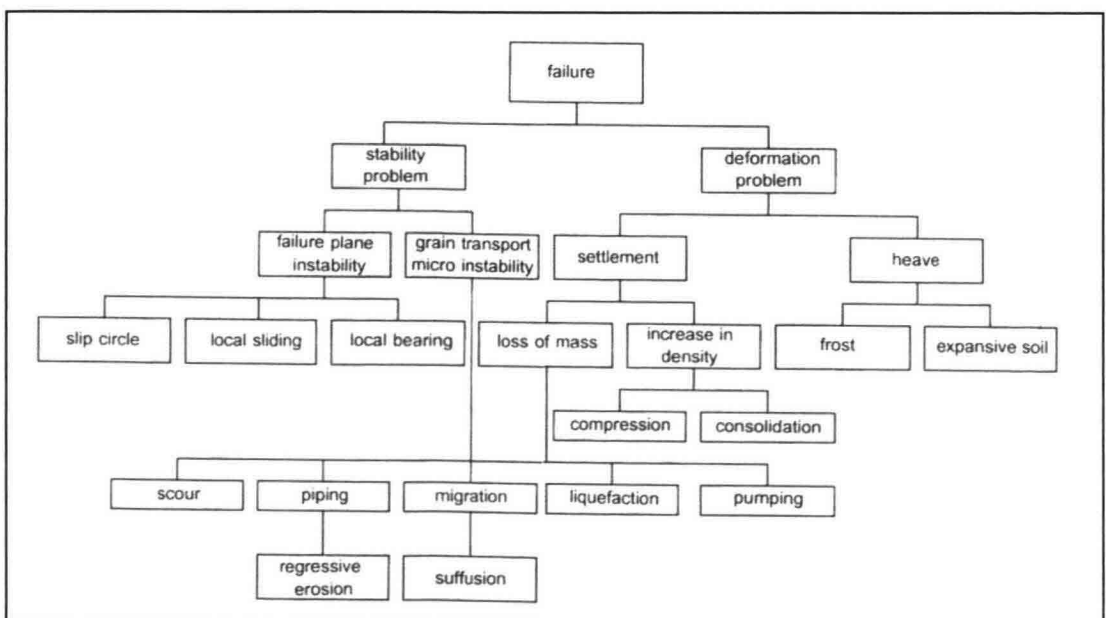

Figure 20 Diagram on failure mechanisms

Last but not least it should be pointed out that the slope does not necessarily have to be the same from crest to toe. For instance, in a riverine environment the upper layers of the soil mass to be protected may be loosely packed and therefore more vulnerable to liquefaction in case of earthquakes than lower layers. The situation can be acted upon by introducing a gentler slope in the upper part of the revetment.

2.4.3 Materials availability

Rock is a widely used material for application in river training structures, as cover or filter layer, but also for ballasting and sinking of mattresses. Selection of materials is basically done on economic grounds (local production vs. importation) but in the meantime this may influence the geometrical design. *Volume* of cross-section (overall quantity of stone), *slope* (density, size of stone) and *layer thicknesses* (filter rules) are most dependent on material availability.

It will however depend on local circumstances whether rock is the most suitable material or not. Other materials or rock material systems like concrete blocks, sand cement blocks, boulders, block mattresses and grouted elements must be considered as well. The selection of a revetment layer cannot be separated from the selection of the “hard” construction material.

The choice between using local or imported rock depends, apart from financial considerations (cost, foreign currency requirements) primarily on the required density, size, construction programme, work methods and on the overall quantities needed. Rock and gravel can be obtained from marine and (local) riverine sources. In deltaic countries like The Netherlands and Bangladesh natural sources are rare and importation cannot be ruled out. For the Eastern Scheldt Storm Surge Barrier stone came from countries as far as Finland and for the Jamuna Bridge Project in Bangladesh potential sources were recognized to be in India, Nepal, Indonesia and Malaysia. However, in most cases the size of the project does not warrant such remote sources of supply to be considered.

2.4.4 Materials supply

Supply of materials can be by means of land-based or waterborne equipment. Considerations which will affect the decision as to which of the options to use, will largely be economic but may also be environmental. For instance, if import of rock to the construction site by lorries or dumper trucks is being considered, the environmental impact of the noise and disturbance of the lorry traffic on the local residents must be assessed

Important practical constraints of land-based material supply can be the width and bearing capacity of roads as well as traffic density between source of supply and construction site. In case river banks have to be used for transport sufficient space has to be provided in the cross-section. On the river, the least available depth along the waterway as a function of the season and in relation to the construction program has to be considered. Because of this time constraint the build-up of a stockpile of material during the high-water season in many cases cannot be avoided, as well as double handling of these materials.

2.4.5 Construction considerations

It must be realized that for most river training structures both waterborne and land based equipment will be required. This may, for example, lead to the requirement to incorporate a berm in the cross-section of a river bank. Construction and launching of a bed and/or toe protection may also be prompted by construction considerations. Obviously, sometimes situations exist where a river runs dry during part of the year, which allows complete construction in a dry environment. In most cases, however, the structure has to be built in a wet environment. In a wet environment two factors are then of interest:

- whether or not the works can be carried out in a current-free and wave-free environment (for instance in a trench dredged in the flood plain)
- whether or not the sediment discharge of the river will have a negative impact on quality of on-going construction works

Both factors have an impact on the design as well as on construction methods.

For instance, a spur-dike to be constructed in flowing water -even if constructed outside the high water (high current) flood season- may require the placing of a bed protection mattress prior to start of construction and a body of weathered rock, sand asphalt or sand cement blocks instead of earth. On top of this body the protective revetment or riprap layer can then be placed in the usual manner though here sediment deposition may jeopardize a neat placing of material, while also tolerances have to be larger than in the case of still water construction. For larger spur-dikes, guide bunds and also for slope protection constructed in flowing water, a system of containment bunds may suffice to allow the placing of successive layers of earth (i.e. sand or silt) behind (bank protection) or in between (spur-dikes) (Figure 21

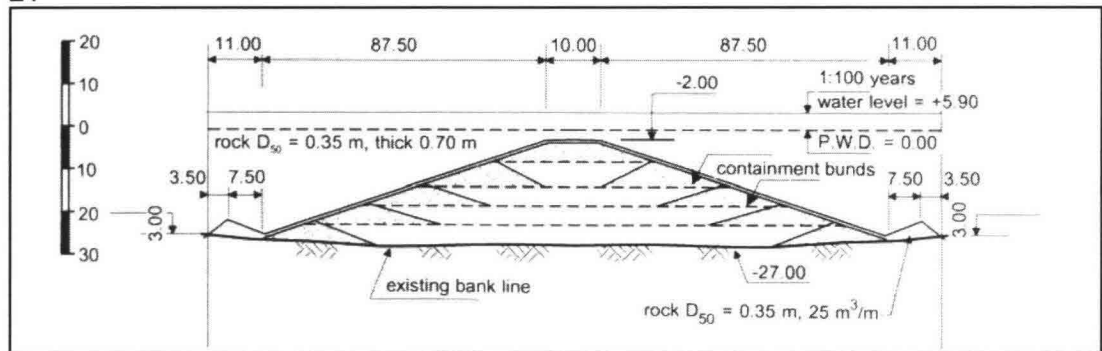

Figure 21 Containment bunds in a spur-dike

To account for scour developments when making the cross-sectional design, in principle, the designer has three possibilities:

- (1) assume that full scour development will take place and, prior to construction, dredge down to the design depth in order to have the toe of the protective layer at the depth ultimately to be reached by the scour;
- (2) no dredging, but make allowance for future scour development by placing a flexible toe protection (e.g. a fascine mattress, as was done for almost all spur-dikes in the Netherlands);

- (3) as for (2), but instead of a mattress, place a surplus of material (i.e. stone) at the toe of the revetment to counteract any future potential geotechnical instability of the slope (falling or “launching” apron).

A toe constructed at full scour depth (1) is the safest, the most conservative and undoubtedly the most expensive as far as construction cost is concerned. Use of mattresses (2) is a proven solution, but construction needs special experience, while the mattress itself should meet the requirements with regard to strength (tensile forces), stability (sliding) and flexibility (scour). The falling apron (3) is more risky in the sense that the behaviour during falling or “launching” is not fully known yet. Nevertheless, this approach has been widely used on the Indian Sub-continent and it must be admitted that this solution has two characteristics, which can be very advantageous in the (local) circumstances:

- it does not require dredging equipment to dredge a trench for a low level toe;
- it may save on initial construction costs (although this may be compensated later by larger maintenance costs than anticipated by the initial structure).

Obviously, a combination of both solutions can have its merits for reasons of risk level and economy, space or availability of dredging plant.

2.4.6 Maintenance considerations

In terms of selection of the appropriate type of cross-section for river training structures, it is important to recognize already at the design stage how and when (i.e. in relation to the flood season) maintenance will take place: using land-based or waterborne plant, by a contractor or by staff of the manager or owner. Some specific points of attention are given to be looked into when designing the cross-section (slope angle, berms, crest width) of river training structures:

- size of stones in view of manual or equipment handling
- stockpile of material for maintenance purposes
- wide crest of spur-dike to allow access for large trucks

2.5 Structure-specific design aspects

2.5.1 Design of the revetment of river training structures

Following the phases of problem identification, formulation of functional requirements and considerations on construction and prior to starting the actual design of the revetment the actions as described in the foregoing Sections must have been taken:

- collection of all necessary data
- selection of overall concept and plan layout
- determination of hydraulic and geotechnical boundary conditions
- consideration of various aspects relevant to the design, materials, construction and maintenance of river training works at a particular

It is now possible to design the revetment, which is the shell of the structure and of which layout and cross-section are thus known in principle. This is done in a number of additional steps which are in principle successive, though during the process the designer may have to go back to earlier steps in order to make corrections. Thus for the design of the revetment an iterative design procedure is used with the following steps:

- (1) geometrical design: slope, crest level and width
- (2) design level of toe, especially in relation to scour
- (3) determination of hydraulic loads (i.e. actual values to replace the indicative figures of Table 1) and other loads
- (4) selection of revetment system
- (5) dimensioning of cover layers and filters
- (6) incorporation of revetment in local structures

The above steps will be discussed hereafter. and

2.5.2 Geometrical design of river training structures

Spur-dikes and sometimes also guide bunds will be subjected to overflow during high river stages. However, this is only of interest for the design of the revetment on the crest as normally the water level at the downstream side of the spur-dike or guide bund during flood is high enough to prevent any critical overflow or through-flow situation as will, for instance, be experienced in closure works.

In the case of long slopes, berms are sometimes designed:

- (a) for stability reasons
- (b) to form a transition between two types of revetments or
- (c) to enable maintenance to be carried out.

In the latter case, the berm should be at a level which allows it to be used for maintenance purpose during a few months each year while also its width must be adequate for equipment to operate.

The 3-D shaping of spur-dikes and the end of guide bunds requires special attention because a wrong shape can lead to pronounced vortices and consequential scour. The aim is to create a more gradual transition between eddy and main flow. For the end profile of spur-dikes slopes of 1:5 to 1:10 are used in practice. Sometimes this problem may best be solved by physical model tests. Examples of the heads of a spur-dike and the end of a guide bund are shown in Figure 22.

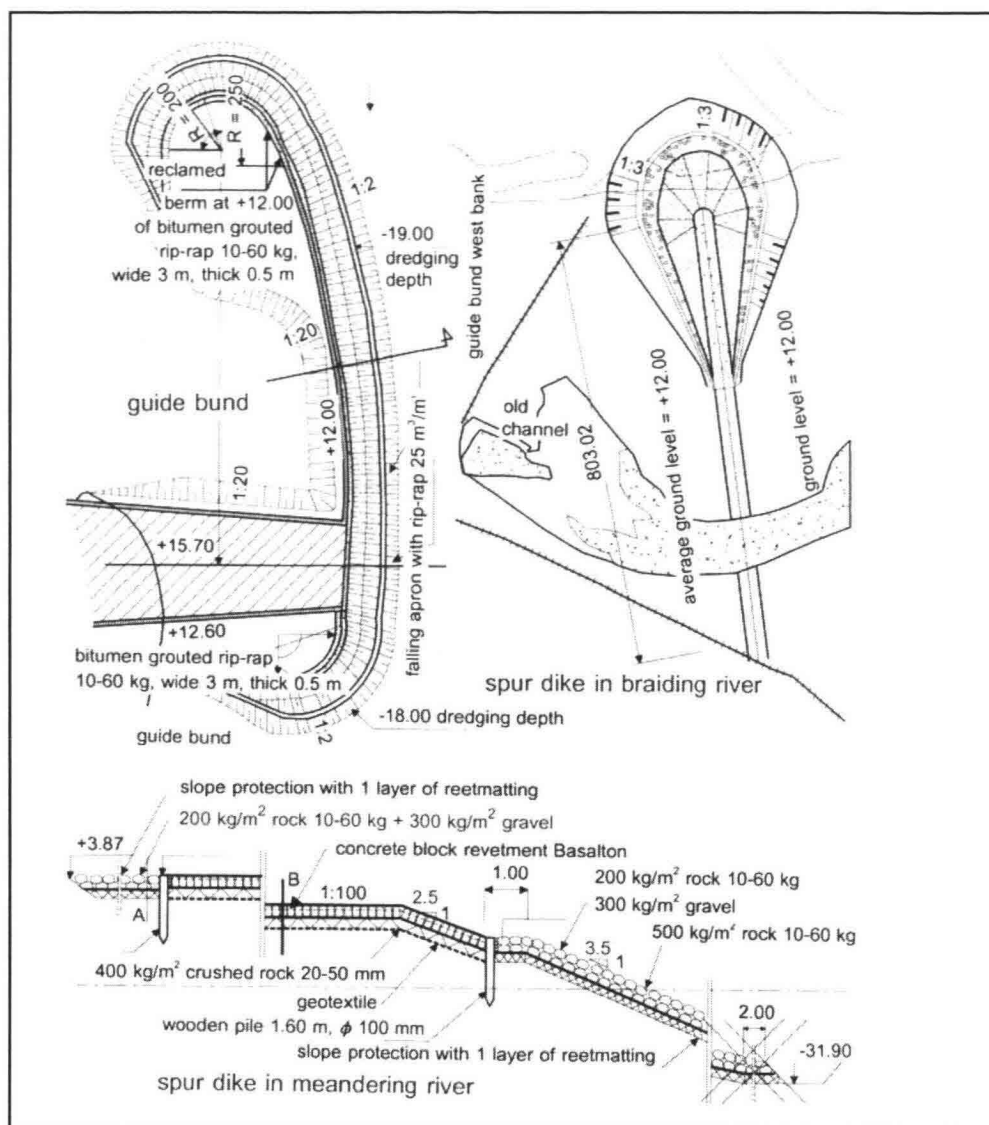

Figure 22 Examples of heads of spur-dikes and end of guide bunds

Crest level and width of spur and longitudinal dikes

The crest level of spur-dikes and longitudinal dikes having a function in channel fixation or construction in meandering rivers is, apart from economy, normally determined by the factors navigation, construction (pitching of revetment on crest to be constructed in the dry) and flood discharge. This implies that the crest should be dry at mean water level, but in case of river constriction for navigation purposes it should -if for instance, the desired depth is 3 m- never be lower than 3 m above the bed in the dominant crossings (Jansen, 1979). The maximum level is determined by the flood plain level, since at high river stages, current concentration and erosion behind the structures should be prevented. The crest of spur-dikes is normally sloping towards the river (1:100 to 1:200).

The crest level of guide bunds as used in bridge projects is normally much higher. Such guide bunds must keep the flow away from bridge abutments and bridge approaches and should therefore not be overflowed. Therefore the height of the crest is determined on the basis of the design water level for the whole project. Overtopping by waves is

normally acceptable. Therefore, freeboard in this case is only required as a safeguard to unexpected settlements and to cater for inaccuracies in water level calculations.

A substantial part of the geometrical design may be the design of a stable revetment toe. This specific problem is discussed in the Sub-Section below.

2.5.3 Stability of the toe of revetments

In view of its importance for revetment design this Sub-Section is attributed explicitly to the stability of the toe of a revetment. Basically, there are three different solutions for the problem of scour at the toe:

- (a) the revetment has its toe at the meeting point between slope and river bed level and *no appreciable scour* (i.e. scour which endangers the stability of the revetment) is expected;
- (b) as above, but now appreciable *scour* is expected and measures have to be taken for this future event;
- (c) in view of expected *scour* the toe of the revetment is placed at time of construction in a trench, excavated in the river bed, flood plain or foreshore.

Case (a) can be found along inner bends of meandering rivers and along the stem of spur-dikes. Extension of the slope revetment over a few metres over the horizontal river bed is normally sufficient. In many cases (spur-dikes) this horizontal protection is already provided anyhow by the edge of the fascine mattress which acts as filter layer on the spur-dike (Figure 1).

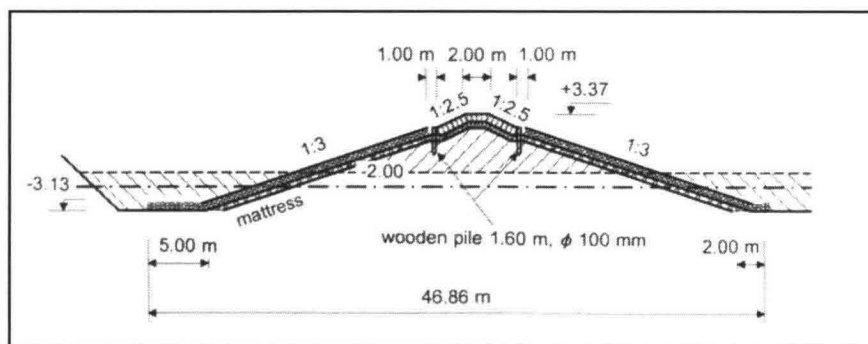

Figure 23 Toe of spur-dike when expected scour is negligible

Cases (b) and (c) have in common that in both cases scour will develop in front of the structure. In case (b) this is counter-acted by a so-called falling or launching. In case (c) the revetment is extended downward in an excavated trench (Figure 25).

The designer will start by predicting the future scour depth. Depending on the outcome and the local circumstances, he will then make a decision to apply either case (b), or case (c) or a combination of both as done in the example of Figure 24.

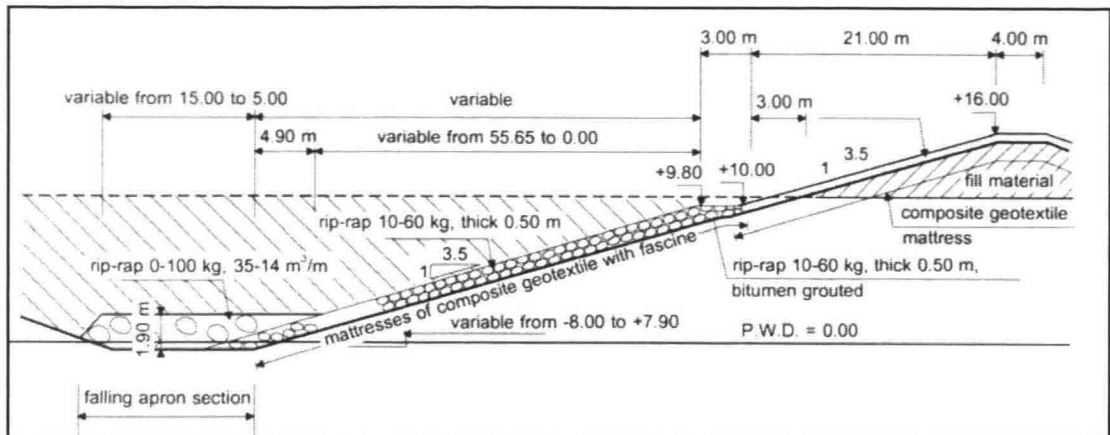

Figure 24 Toe of guide bund with falling apron

A general discussion on scour is not given here. River training works, depending on the nature of the river and the type and location of the structure, will be exposed simultaneously to various types of scour:

- Local scour
- General scour
- Constriction scour
- Confluence scour
- Bend scour
- Protrusion scour

Not all of these types of scour will develop at any particular structure, neither do they have the same magnitude. A complicating factor is that -to a certain extent- the types of scour are inter-dependent or (partly) correlated. Finally, existing formulae are still very specific to one particular river and far from generally applicable. It is therefore impossible to give a general rule of thumb or formulae for the maximum joint scour to be expected. Because of the stochastic nature of some types of scour, it is possible to determine the joint scour depth for a range of exceedance probabilities.

After having verified by calculations that the joint scour or rather its consequences, have an acceptable probability of exceedance, the designer will have to decide what counter-measures to take. This decision will depend very much on:

- whether there is a possibility or not to construct a revetment in a dry trench down to the expected scour depth
- whether dredging down to future scour level is a realistic possibility, in view of costs involved, available equipment and workability (currents)
- whether it can be expected that a falling apron (discussed below) will work

Falling apron

Basically, a falling or “launching” apron is a ridge of stone, dumped at the toe of a revetment. The stones are supposed to move in downward direction when scour develops in front of the toe. The idea behind the falling apron is that it provides future coverage of the slope of the scour hole by loose granular material. The length and quantity should be sufficient to cover the entire downward slope when developed in the future. The thickness and the grading of the granular material should be such that, at the end of the falling process, the underlying soil is still retained by the protective layer.

Toe scour will usually occur generally along a toe structure, but may also show marked local scour holes. When selecting from the three options listed above, it should be considered that a falling apron does only work when it is also flexible in the direction along the toe structure. For this reason, an apron consisting of only wide-graded rock seems preferable, since any extra stiffness associated with additional materials such as geotextiles and/or fascines may disable the apron to follow a local scour development. The apron then fails to perform its protective function.

The careful designer is also reluctant to extrapolate from experience obtained on other rivers and at smaller depth. One must also bear in mind that a falling apron -in case of scour- will automatically result in a steep revetment (natural slope 1:2). It must however be noted that such a slope is *not* stable in case of an earthquake. The following example on application of a falling apron is given to illustrate this dilemma.

For the Jamuna Bridge Project in Bangladesh, it was originally decided to have the (dredged) toe of the revetment of the guide bund at PWD -10 m (all depths given relative to PWD). Scour could develop to a depth of -25 m. Accordingly, a falling apron was designed which was placed at -10 m and could “fall” down to -25 m. During the detailed design stage this was considered too risky. It was decided to have the falling apron operating from -18 to -27 or (locally) -30 m. In this case it was felt that:

- Dredging from flood plain level at +12 m down to a level of -18 m was a maximum in view of cost (areas of cross-section to be dredged) and equipment availability;
- On the other hand, 10 to 12 m difference in height seemed to be a maximum to be adhered to for reliable “apron launching” with not much damage.

In the same project at another site, less vulnerable to scour, the design of the bank protection included a falling apron from +8.80 m to -20 m as it was felt that:

- it was much less probable that scour would ever develop down to that particular depth and
- if it did and the apron would not properly function, no serious consequences were expected

2.5.4 Determination of hydraulic and other loads

(a) Hydraulic loads

By using the various formulae and modelling techniques the designer has to transfer boundary conditions, such as ship movements, wind data, river discharges and flood waves, through the various hydraulic interactions into loadings. These loadings are:

- water levels (and their variations with time, also in regard to geotechnical stability !)
- current velocities
- wind and ship-induced waves

Apart from that it is important: (i) to know the timing of wind waves in relation to water levels and currents and (ii) to choose a *return period* for stochastic variables as wind speed and direction, water levels and (related) fetch lengths and current velocities, to arrive at *design loadings*.

With regard to joint probabilities, in case of combined loadings, care must be taken not to add design loads originating from different independent phenomena. For instance, a

1:100 years wind-speed and corresponding wave height does not necessarily coincide with a 1:100 year water level and related current velocity.

(b) Forces during construction

In particular for under layers and mattresses the largest loadings occur during construction. This can be due to the weight of the structure itself (e.g. in the case of a mattress placed on a relatively steep (1:3 or steeper) slope or due to impact forces caused by dumping of stones. In this respect, to prevent damage to a geotextile, dumping of stone coarser than grading $60 \text{ mm} < D < 300 \text{ mm}$ is not advised. In case this is unavoidable, another method of placement or an intermediate granular layer should be applied. Another example is a granular filter layer exposed to extreme conditions (waves, currents) during construction.

(c) Other loads

Apart from hydraulic forces and forces acting on the revetment during construction, other loads can occur. A check list is given here but it is not comprehensive for every project. The designer will have to quantify the effects as far as possible and decide if they provide a determinant design condition.

Table 2 Other causes of damage

FEATURE	CAUSE	EFFECT	DESIGN MEASURES
Abrasion	Ice floes and debris floating in the waterway	Impact near waterline. Displacement of armour; puncturing of membranes	Design for resistance to impact. Allow for easy repair. Deflect water flow (by groynes)
	Boulders to coarse sand (associated with high velocity flow)	Grinding action at toe wearing through exposed fabrics, gabion baskets	Design for resistance to impact. Allow for easy repair. Deflect water flow (by spur-dikes)
	Pack Ice	Shearing force on cover-layer due to ice-sheets riding up the revetment	Provide cover layer able to withstand load (design procedures are available)
Biological	Livestock	Grazing and trampling leading to destruction of vegetative protection	Fence-off revetment. Use non-degradable reinforcement to soil
	Vermin	Burrowing into bank. Gnawing through geotextiles or cables	Pest control. Provide an impenetrable top layer
	Plant growth	Roots after geometry of top layer	Vegetation control if necessary
	Seaweed and algae	Surface damage to asphaltic top layers	Bituminous sprays
	Microbes	Attack some natural fibres	Use resistant materials unless degradation is a specific requirement
Chemical	Oils and hydro-carbons	Attacks bituminous systems	Avoid contact
	Sulphates	Attacks concrete	Use sulphate resisting cement
	Other aggressive salts	Corrosion of steel wire, cables, connections	Protect by galvanising and/or PVC coating. Use heavier wires and cables, or suitable stainless steel wires and cables
Temperature	Frost heave	Formation of ice crystals in subsoil leading to change in geometry of top layer	Use non-capillary soils in frost susceptible zones
	Extremely low temperatures	Embrittlement of geo-textiles	Check working temperature range of material
	High temperatures	Creep of geotextiles. Flow of bituminous materials down slope.	Check working temperature range of material
	Freeze/thaw	Spalling of rock or concrete armour	Use good quality, durable top layer

FEATURE	CAUSE	EFFECT	DESIGN MEASURES
Human action	Vandalism or theft	Cutting and removal of geotextiles; cutting of cables; removal of riprap or loose concrete blocks; fire damage. More common in urban areas and poor rural areas	Provide protective cover to fabric. Use heavy-weight top layer
	Washing places	Fill material between stones get lost; stones are undermined	Special interlocking stones or fixing of stones with asphalt
	Mooring of small craft to poles in revetment	Stones are ripped out of revetment	Provision of special mooring devices
Traffic	Ship/ bank collision	Local destruction of revetment	Allow for easy repair or if failure is unacceptable then design to resist impact or incorporate a fender structure
	Dragging anchors	Local abrasion of top layer and possibly sub soil	Provide stronger top layer in areas where ships are likely to anchor
	Over dredging	Accelerates toe scour	Better maintenance control
Ultra violet light	Sunlight	Loss of strength and degradation of geotextiles	Use a stabilised material; limit exposure to sunlight during construction and when in use

2.5.5 Sectioning of slope and revetment

From the various data collected and summarized in section 2.5.4 it is possible to determine the design loading for various parts of the slope. Normally, design wind speeds as well as water levels and current velocities vary with time, often with an underlying seasonal variation. This enables the designer to divide the slope into distinct sections, each having its own loading, given under a) to c) in section 2.5.4.

It is noted that also combinations, as well as the period of exposure to the above loads (e.g. number of waves, tides or length of flood wave), must be considered.

Apart from this hydraulic loading the other loads as listed in Table 1 have to be considered. For instance, if vandalism is expected then part of the slope permanently under water can be designed differently from the upper part of the slope which is above water for a few days or more during the year.

All these considerations must however not result in a revetment on a slope which changes in downward direction every few metres in nature, composition and thickness. This would not be practical from a construction point of view. Besides, revetments usually show a combination of reduced strength and increased loading along such transitions.

2.5.6 Selection of revetment system

The variation in loading along the downward slope may result in different revetment systems being selected. This selection does not as much concern the dimensioning, but the material(s) to be used and the building-up of composite layers. This selection is typically site-specific. It means that not necessarily all requirements earlier are relevant or equally important. Moreover, one must try to look only at the main issues and then only at those which are different for each revetment system. Also requirements which can easily be met by each system through dimensioning should be disregarded.

2.5.7 Dimensioning of revetment

The aim of this section is to outline a practical design procedure for a flexible open revetment, set against the background of information presented in the earlier. The design procedure is:

- (1) assess the erosion resistance of the subsoil
- (2) design the cover layer for stability against hydraulic loading
- (3) determine the upper and lower limits of the cover layer (for water levels and wave run-up)
- (4) design the filter fabric
- (5) design the sub-layer if required
- (6) design any transitions between different systems as well as toe protection and edge details

Each of these six steps will now subsequently be looked at in detail.

(1) Erosion resistance of subsoil

The question which the designer has to answer is: where can I stop with providing a revetment and trust that the adjacent non-protected soil will not erode or, if it does, will not lead to collapse of parts of the revetment. In practice this means that hydraulic loads (currents, wave attack, water level variations) must be assessed at the boundaries of the revetment and, more in general, of the river training structure involved:

- at the toe of a bank protection (scour of riverbed)
- along the slopes of a spur-dike (eddies)
- at the root of a spur-dike during overflow
- behind a non-overtopping guide bund (as a consequence of meandering or shifting river channels or eddies)

(2) Design of revetment cover layer

Revetments in river training structures normally have to be designed for hydraulic loadings: currents, wind or ship-induced waves or combinations. In wide rivers, ship-induced hydraulic loads play a lesser role.

In section 2.7 calculations are presented, which have been made for the cover layer of a revetment as part of bank protection works along the Meghna River in Bangladesh. This revetment consisted in the upper dry part of stone asphalt, but the under-water section and the falling apron consisted of boulders. It is, however, interesting to note that due to construction (sinking) requirements, a larger diameter was chosen than was needed to resist the hydraulic forces.

(3) Upper and lower limits of cover layers

Assuming that the cover layer has a D_{n50} of 0.15 m, it is possible to determine the upper and lower limits of the layer by using the largest of the standard fine gradings (80/200 mm). This corresponds ($r_f=2650 \text{ kg/m}^3$) to a mass range of $W=1$ to 20 kg with an average mass of individual stones of 10 kg (approx.) and satisfies the required $D_{50}=0.15 \text{ m}$ (a cube having sides of 0.15 m has a mass of 9 kg). The minimum cover layer thickness (t_c) for under-water slopes depends on the construction method, with a minimum of $2 D_{n50}$ (' $1.5 D_{50}$), which in this case results in $t_c=0.30 \text{ m}$.

(4) Design of filter fabric

In principle, it would be possible to use a granular filter between subsoil and cover layer. In practice, geotextiles are more and more used for this purpose. Indices "f" and "b" refer to filter and base (subsoil) material respectively. The criterion concerns the interface stability or sand tightness. It is noted that for non-woven geotextiles a slightly different criterion is used (see **Error! Reference source not found.**).

Table 3 Criteria for geotextile filters

Type of geotextile	Sandtightness *)	Permeability, kg **)	Permittivity, Ψ_g
Woven	as given	A=10	$\Psi_g > 0.1 \text{ s}^{-1}$
Non-woven	as given	A=50	$\Psi_g > 0.1 \text{ s}^{-1}$

*) under steady flow conditions

**) well graded soil

in which:

- O_{90} = effective opening size of geotextile (m)
- D_{90b} = characteristic size of subsoil particles (m)
- k_f = permeability geotextile filter (m/s)
- t_g = thickness of geotextile (m)
- k_b = permeability of base material or subsoil (m/s)
- c_g = permittivity of geotextile; $\Psi_g = k_f / t_g \text{ (s}^{-1}\text{)}$

To satisfy the requirements, in many cases a composite geotextile is required which consists of a combination of a woven (for strength) and a non-woven (for sand-tightness).

If it is assumed that the soil (base) is described by the following characteristics: $D_{50}=60 \mu\text{m}$, $D_{90}=90 \mu\text{m}$ and $k_b=3.5 \cdot 10^{-5} \text{ m/s}$, then specifications for woven and non-woven geotextiles can be given as listed in Table 3. Additional specifications with regard to strength and weight -related to construction and rock placement- are also included.

Table 4 Geotextile specifications; woven and non-woven

type of geotextile and opening size (O_{xx})		
criteria	woven (polypropylene) $200 \mu\text{m} < O_{90} < 300 \mu\text{m}$	non-woven $O_{90} < 125 \mu\text{m}$ $O_{50} < 75 \mu\text{m}$
specifications		
Tightness (effective pore size, O_{xx})	$O_{90} > 180 \mu\text{m}$	$O_{90} < 180 \mu\text{m}$
Permeability (k_f)	$k_f > 3.5 \cdot 10^{-4} \text{ m/s}$	$k_f > 17.5 \cdot 10^{-4} \text{ m/s}$
(Permittivity, c_g)	($c_g > 0.1 \text{ s}^{-1}$)	($c_g > 0.1 \text{ s}^{-1}$)
Thickness (t_g)	$t_g \leq 3.5 \text{ mm}$	$t_g \leq 17.5 \text{ mm}$
Strength		70 kN/m
Strength wrap and weft	70 kN/m	
Grab strength		> 900 N
Weight	450 g/m ²	200 g/m ²
Width on roll	> 5 m	> 5 m

Apparently in this case, only the non-woven geotextile can satisfy the sand tightness criterion. Additionally, this filter should also satisfy the permeability requirement listed in **Error! Reference source not found.**, which also shows the resulting value for k_f and finally shows that the geotextile thickness should not exceed $t_g=17.5 \text{ mm}$, a requirement which can be met easily.

Apart from the previous calculations, also durability (additives) and required strength during placement of the geotextile or dumping of rock may be determining for the actual thickness of the geotextile.

(5) Design of granular sub layer

Apart from the option of a full (multi-layered) granular filter also a composite filter, consisting of a geotextile and a granular filter (sub)layer may be applied. The granular sublayer, between the geotextile and the base material would for instance be required if the geotextile alone does not provide for a sufficiently tight filter structure.

By means of example, it is assumed here that no geotextile composite filter is used, but only a woven type with characteristics as shown in Table 4. In that case, the revetment consists of

- the cover layer ($D_{n50}=0.15 \text{ m}$)
- the geotextile filter
- the granular sub- or filter layer and iv) the soil or base material ($D_{50b}=60 \mu\text{m}$)

The granular sub-layer (i.e. the D_{90f} and D_{50f}) should satisfy the following requirements

- (1) geotextile tightness; $O_{90}/D_{90f} \geq 2$;
- (2) tightness of granular sub layer: $D_{50f}/D_{50b} < 10$ to 60 ;

Tightness of the geotextile ($O_{90} < 300 \mu\text{m}$) with regard to the granular sub-layer requires a minimum size of the sub-layer material: $D_{90f} > 150 \mu\text{m}$ (0.15 mm). On the other hand, the tightness requirement put by the base material ($D_{50b}=60 \mu\text{m}$) to the granular sub-layer, implies that $0.6 \text{ mm} < D_{50f} < 3.6 \text{ mm}$ (which does not conflict with the previous requirement).

A sub-layer with $D_{f50}=0.6 \text{ mm}$ (600 μm) will just satisfy both requirements. Obviously, between this sub-layer and the base ($D_{50b}=60 \mu\text{m}$ or 0.06 mm), no additional sub-layers are needed. This conclusion is not changed by considering the criteria for internal and interfacial stability and permeability, segregation and piping; see Table 5.

Table 5 Granular filter criteria

Criterion	Constraints
permeability	$D_{15f}/D_{15b} > 4$ to 5
segregation	$D_{50f}/D_{50b} < 20$ to 50
piping	$D_{15f}/D_{85b} < 4$ to 5
internal stability	$D_{60f}/D_{10f} < 10$ no migration

(6) Transitions between different systems, toe protection, edge details

(i) Local structures to be incorporated

River training structures like guide bunds and bank protection works may have to be crossed by ferry landing jetties, cables, pipelines, sewage outlets, drainage outlets. Such crossings are not desirable from a design, construction or maintenance point of view. Piles of jetties may disturb the filter layer and cause local turbulence, cables may be pulled and then tear through the revetment, pipelines as well as sewers and drain pipes may leak and cause geotechnical instability followed by serious damage to the revetment. Chemicals in waste water may damage materials used in revetment systems.

Nevertheless, in most cases such local structures have to be there and all the designer can do is to make the best of it and to carefully analyze the risk involved, specifically by comparing the local risk of failure with that of the rest of the revetment. Subsequently, he then should design suitable measures to counteract any possible mishap.

2.5.8 Transitions

In addition, some general comments must be made on each location where a transition takes place, i.e. problems related to:

- toe protection
- top edge of the protection
- flank protection
- construction in the dry or in the wet

At the *top edge* of the protection there is -especially when the protection layer consists of riprap- a discontinuity in terms of height, permeability and hydraulic roughness of the surface. This may lead to undermining and require installation of a transition layer

between the actual protection layer and the unprotected soil. Obviously the need for such a transition layer only arises when hydraulic loads do occur more or less frequently in this area.

Flank protection is needed to limit vulnerability of the revetment to erosion continuing around its ends. Extension of the revetment beyond the point of active erosion should be considered, but is often not feasible. In less severe cases, a thickened or grouted cover layer or a cover layer turned into the slope can be used in this region.

As a general rule, transition with another type of revetment in the longitudinal direction of the bank should be avoided wherever possible. It is desirable that a bank slope should be protected by one type of revetment from the toe to the top edge. This is not always easy to achieve, for instance when a revetment is being extended or if different systems are adopted for the lower and upper parts of the revetment. In such cases the designer must carefully consider the consequences of uplift pressures under the cover layer.

In Figure 25 revetment system 'A' is stable with regard to uplift pressures i.e. the permeability of the cover layer is greater than the permeability of the sub-layer and/or subsoil. If a different revetment system 'B' is introduced downslope of A it is imperative that the permeability of the sub-layer or subsoil 'A' is less than the permeability of the sub-layer or subsoil 'B' with which it forms an interface. If this is not done then serious uplift pressures can occur under cover layer 'A'. For instance, a granular sub-layer in revetment 'A' should be avoided if cover layer 'B' is placed directly on a clay foundation.

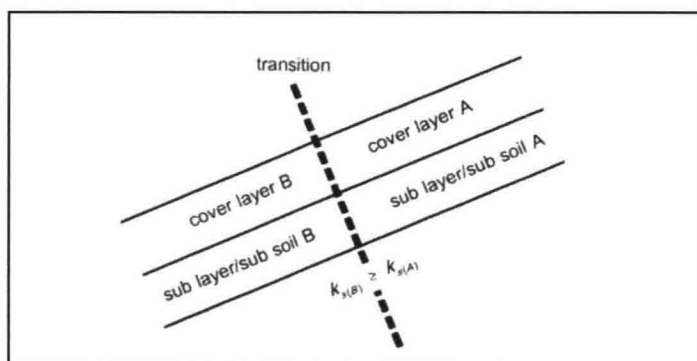

Figure 25 Diagrammatic representation of longitudinal transition

Transitions parallel to the bank should be reinforced in one of the following ways:

- increase the thickness of the cover layer at the transition
- grout riprap or block cover layers with bituminous grout
- use concrete edge-strips or board to prevent damage progressing along the bank

2.5.9

Example of the structural design of the cover layer

In this Section, the design of a cover layer is demonstrated. Loadings considered are natural currents and waves. The example concerns the evaluation of hydraulic stability of the cover layer..

Current attack is relevant only for the under water part of the revetment, whereas wave loading is considered for the part above water. In the following **Error! Reference source not found.**, each of the parameters involved in the determination of the boulders size will be discussed for the bank protection works at Bhairab Bazar.

Table 6 Stability against current, values for use in formulae of Pilarczyk

Parameter	Value	Remarks
U	1.95 m/s	According to the maximum current velocities near the banks which have been measured in the physical model tests along overall bank protection for Bhairab Bazar area.
h	15 m	For waterdepth an average depth over the slope protection of 15 m has been used.
γ	1.60	For Bhairab Bazar, the water density is $r_w=1000 \text{ kg/m}^3$ whereas per specification of the BWDB the density of the boulders is $r_r=2600 \text{ kg/m}^3$.
tga	1:3.5	For geotechnical stability a slope of 1:3.5 is recommended. All the slopes which will be formed should stay at or below this value. Only small transition zones may exceed this value up to 1:3.5.
k_{sl}	0.88	For current perpendicular to the river bank gradient $k_{sl} = k_d$; see Eqs. (5.82) and (5.84).
k_t^2	1.8	Fairly high but not excessive turbulence was expected in this area up to 20%.
f	35^0	
f_{sc}	1.0	For boulders on a mattress a stability factor for current of $f_{sc}=1.0$ is used
c_{cr}	0.035	The critical Shields shear stress for "no movement" has been applied: $c_{cr}=0.035$
L_h^i	80	Specific depth factor for $h = 15 \text{ m}$ and estimated $D' 0.1 \text{ m}$

Results for current attack

Substituting the values given in Table 6 yields $D_{n50}=0.09 \text{ m}$ so $D_{50}=0.11 \text{ m}$, with a consequential layer thickness ($t_c = 2 D_{n50}$ or $2 D_{50}$) of $t_c=0.2 \text{ m}$ (approx.). However, in view of the thickness of fascines and related construction (sinking) requirements, this should be $t_c=0.3 \text{ m}$ (approx.). Reversely, starting with this thickness and applying $D_{50}=1/2 t_c$ (approx.), boulders with $D_{50}=0.15 \text{ m}$ are proposed.

The final dimensioning will be done after the probabilistic calculations have been performed.

Results for wave attack

For the dimensioning of the upper part of the protection (open stone asphalt) against **wave attack** use is made of Eq.(5.117). The thickness of the open stone asphalt layer can be derived by substitution of the values for Bhairab Bazar, given in Table 7.

Table 7 Stability against waves, values for use in

Parameter	Value	Remarks
H_s	0.98 m	
T_z	3.51 s	
j_m	1.0	This parameter is set at 1.0
'	1.0	For open stone asphalt ' can be set at 1.0.
tga	1:3.5	For geotechnical stability a slope of 1:3.5 is recommended. All slopes to be formed should be at this angle or less steep.
f_u	6	This upgrading factor is set to 6,
f_{sw}	1.0	This stability parameter for waves is set to 1.0

Substituting these values in the aforementioned formula yields a minimum value for the thickness of the layer of $t_c=0.15$ m.

The open stone asphalt layer is placed up to 3.00 (m +PWD) and allows the placing of the open stone asphalt under dry conditions. The level corresponds approximately with a water level that is not exceeded during 50% of the time.

3 BED PROTECTION, REVETMENT AND LINING IN NAVIGATION AND WATER CONVEYANCE CANALS

3.1 Differences between rivers and canals

The basic difference between natural water courses (i.e. rivers) and navigation/water conveyance canals is that the latter are man-made.

For this reason the dimensions of these canals concerned are solely based on economy and functional requirements. The flow profile is as small as is acceptable in the circumstances and remains the same over long distances. The alignment is straight or slightly curved. Water levels are kept within narrow margins, maximum current velocities are well known and kept low or, alternatively, there is no (natural) current at all. In line with the foregoing, bed gradients are zero or otherwise kept as small as possible. Last but not least, in most cases water losses due to seepage are not acceptable.

Rock is also applied in these canals though to a much more limited extent than in rivers. Because of different hydraulic loads and functional requirements, the designs for application of rock in canals may differ considerably from those applying to river training works. This explains why two separate Sub-Chapters are devoted to these subjects.

3.2 Types of structures, functions of canals and structures

Rock is applied in navigation and water conveyance canals as slope protection and as bed protection.

The functions of slope and bed protection in these canals are:

- to prevent erosion of the underlying soil mass and/or filter layers

- to prevent instability of the slopes which could lead to sliding or liquefaction which in turn may result in an undesirable reduction of the canal profile or a collapse of the canal retaining embankment
- to form a water-tight barrier (this function is not always required) between canal and its environment
- to minimize friction losses and/or allow for higher current velocities
- to maximize friction losses to reduce current velocities

Because of differences in functional requirements between various types of canals, rock-based structures will also differ. Therefore a short description of the functions and particulars of each type of canal will be given.

3.2.1 Navigation canals

The bank protection in navigation canals is designed to prevent erosion of the slope and of the canal bed near its toe due to ship induced water movements. Though wind waves can play a role in wide and deep navigation canals, they are mostly of minor importance if compared to waves, currents and water level variations, induced by ships. Bed protection will normally not be required apart from some protection near the toe of the slopes in shallow canals. In order not to hinder ship movements, current velocities in navigation canals are normally zero or low.

Low current velocities can be a consequence of filling or emptying of navigation lock chamber(s) at the end of a canal. Tidal movement in a navigation canal not only will induce currents but also varying water levels. The latter has an impact on the extent of the zone of exposure to ship-induced water movements.

Finally, currents can also be due to a drainage or irrigation function of the canal.

This irrigation/drainage function is nearly always of small importance and one can therefore say that the water conveyance function of a navigation canal is secondary.

Bed protection in a navigation canal will normally only be required:

- at any location where ships will manoeuvre and erosion occurs due to propeller thrust (always provided that scour is acceptable as long as adjacent structures are not endangered)
- near the inlet/outlet of lock chamber filling/emptying culverts
- near the inlet/outlet of irrigation/drainage sluices or pumping stations
- to protect (buried) cable or pipeline crossings

Generally speaking, one has to admit that bed protection in navigation canals is not favoured because of the limitation it poses to anchoring. Moreover, if anchoring occurs, it will seriously damage the bed protection works, unless the bed protection is intentionally constructed to resist anchoring.

3.2.2 Water conveyance canals

Water conveyance through canals is done for irrigation, drainage, domestic/industrial water supply and as part of hydropower projects. Two or more of these functions can be combined or combined with navigation: Typical examples are:

- Indonesia, West Tarum Canal for irrigation and also water supply to Jakarta;

- Egypt, Ismailiya Canal for water supply to Ismailiya, but also irrigation and navigation;
- Jordan, King Abdullah Canal for irrigation, domestic and industrial water supply.

As the water conveyance function will induce current velocities, bank and bed protection in water conveyance canals cannot always be avoided. Bank and bed protection in water conveyance canals will have to satisfy different design requirements depending on the function of the canal and boundary conditions. This can best be illustrated by some elaboration on the aforementioned functions:

- **Irrigation and water supply** canals will follow, if possible, the contour lines but this is not always convenient. The basic aim is that the water arrives at the selected area along the shortest possible route with minimum losses due to evaporation and infiltration. This may necessitate a relatively steep sloping canal with so-called drop structures (i.e. energy dissipating structures) at regular distances to reduce current velocities and to destroy energy. Bank and bed protection works will be avoided if at all possible and these are therefore normally limited to the area of sharp bends, drop structures, bridges and irrigation off-takes. A special kind of protection is lining which implies that slopes and bed are lined with concrete or asphalt to prevent water losses due to leakage. A combination of a water-tight membrane with stone (pitched, quarry-run rock) on top could probably have the same function. Though the aim is to trap sediment before the water enters the canal, this is not always feasible, while also lack of maintenance can have had a negative effect. Accordingly, some large irrigation canals look and behave like meandering rivers.
- **Hydropower** requires a water conveyance canal having an alignment which is as horizontal as possible and a profile being hydraulically as smooth as possible. This all in order to keep head losses -due to friction- to a minimum. The implications are that current velocities will be low and bank protection/lining -if required- has to be smooth. Accordingly, one will find in these canals only bank and bed protection systems, like concrete slabs or blocks, pitching or stone masonry. Also here water losses due to seepage in general should be low and this requires a closed revetment system.
- **Drainage** will normally follow the natural patterns of water courses. Only in flat areas the drainage will have to take place along a system of canals specifically designed and constructed for this purpose. The designer aims at minimum friction losses and this implies that no protection of banks and canal bed is required to prevent erosion by the (low) current velocities.

3.3 Plan layout and overall concept selection

As stated earlier, canals are man-made which implies that the overall design will be based on functional requirements and economy. Slope protection (and bed protection to a lesser extent) will be an integral part of the design process as it can form an important cost factor. The design of navigation and water conveyance canals as such is however not the subject of this Manual and any design considerations in this respect will only be mentioned briefly below. For specific design methods relevant to navigation canals, reference is made to PIANC (1987a) and PIANC (1987b).

For each type of canal most important design aspects are the following:

General

- topography
- slope and bed protection
- environmental considerations

Navigation canal

- dimensions and method of operation of navigational draft
- dimensions and types of structures and bends in a navigation canal
- economic value of waterway
- earth balance: cut and fill
- translation waves induced by navigation lock operation
- recreational purposes
- ships intensity in relation to number of fairways
- desirable and possible allocation of space in relation to selection of cross-section (rectangular, trapezoid or combination)
- any additional considerations: tides, waves, water conveyance

Irrigation/water supply

- volume of water to be transported as a function of time and place, resulting in a relationship current velocity/water depth while also frequency of both parameters can be determined
- dimensions and type of structures: drop structures, bridges, siphons, irrigation off-takes
- maintenance considerations especially actions required to fight sedimentation and weed growth
- earth balance: cut and fill
- economic cost of canal as part of whole project
- leakage to be avoided or very low
- translation waves

Hydropower

- volume of water to be transported as a function of turbine operation and possible storage at end of canal
- leakage to be avoided or very low
- desire to minimize friction losses which has an impact on current velocities and desired bed and slope roughness
- earth balance: cut and fill
- translation waves
- desire to minimize overall head loss
- economic cost of canal as part of whole project
- maintenance considerations especially in view of weed growth and sedimentation which result in loss of canal profile and increased friction losses

Obviously, the design of a completely new canal offers the possibility to determine type and particulars of slope/bed protection as part of an iterative design process, during which various alternative solutions are developed and analyzed.

Strictly speaking, a distinction should from now on be made between the various types of canals as hydraulic losses as well as functions of slope/bed protection may differ. This would, however, lead to many repetitions. Therefore, in the next Section the

navigation canal will be the point of departure and, if required, supplementary remarks will be made about possible deviations for other types of canals.

3.4 General considerations for cross-sectional design

3.4.1 General

From the foregoing it can be concluded that a number of considerations regarding the cross-section of bank and bed protection systems in canals have already been taken into account at the time the overall design of the canal is made. The following aspects will be discussed:

- relationship between overall canal design and design parameters for slope/bed protection
- physical boundary conditions
- materials availability and supply
- construction considerations
- maintenance considerations
- requirements for revetment layer

3.4.2 Design parameters for slope/bed protection as a function of overall canal design

Given the design for a new canal or a canal which already exists, it is possible to list relevant design parameters for slope/bed protection:

- shape of cross-section and more specifically, the side slopes of the canal
- current velocities and water depth due to discharge function and/or tidal motion in the canal
- hydraulic roughness
- permeability
- radii of bunds and possible local widening
- dimensions and level of berms (if any)

In addition for navigation canals the following will have been determined:

- width at water level
- width at bed level
- types and particulars (dimensions, geometry) of ships
- navigation behaviour of ships (speed applied, position in canal)
- ship-induced water movements
- draught as a function of time of the year and direction of the ship
- traffic intensity (especially required in view of probabilistic design)

3.4.3 Physical boundary conditions

In fact a number of the particulars of the canal design as presented in Sub-Section 3.4.2 above form physical boundary conditions for the cross-sectional design and for the overall and hydraulic design of the slope and bed protection.

In addition, wind and waves, seismic activity, ice formation, all as far as applicable in the circumstances, together with geotechnical boundary conditions shall be taken into account as outlined in Chapter 4. For a more detailed discussion of hydraulic and

geotechnical boundary conditions reference is made to Sub-Section 2.4.2 as most of what is said for river training works also applies to canals.

As for river training works, the combined action of wind waves, discharge, tidal currents on the one hand and ship-induced water movements on the other hand must not be overlooked. Again, attention should be given to the possibility of future changes such as scour in front of structures, through reduction of the passive resistance of the soil, flow slides may be provoked.

3.4.4 Materials availability and supply

The same kind of considerations earlier presented for structures used in river training are valid for slope and bed protection in canals. One additional remark must be made: When designing water conveyance canals a design criterion, following from cost considerations or otherwise, can be to keep current velocities low to enable the use of locally available weathered rock, fine gravel, bricks or brick chippings. Such materials are normally not suitable for river training structures or slope/bed protection in navigation canals, as current velocities in that case are much higher and cannot be kept low by adapting the design without incurring considerable additional cost.

3.4.5 Construction considerations

A clear distinction must be made here between a new canal and an existing one.

When a *new* canal is built, the designer in principle still has the option to either build it in the dry (as a dry excavation and fill operation) or in the wet (as a dredging and reclamation operation). The choice will in practice, depend on:

- groundwater table
- suitability of soil for dredging operations
- availability of dredging equipment in country concerned
- water availability
- environmental effect of drain water from dredging
- cost involved
- whether or not in fact such a canal is constructed by dredging/reclamation

Generally speaking, a navigation canal situated in a deltaic area with a high groundwater table will be dredged, while a water conveyance canal in an arid climate will either be excavated using heavy earth-moving equipment or even dug by hand. Obviously, the decision on the above -in turn- determines whether the slope/bed protection will be made in the wet or in the dry.

For an *existing* canal the slope/bed protection works will practically always have to be constructed in wet conditions unless the canal stays dry part of the season (e.g. an irrigation canal). The decision “wet” or “dry” environment during construction, as well as the construction procedures, methods and equipment have both an impact on the design because:

- it determines what slope/bed protection systems are (un)suitable; for instance stone or block pitching and brick placing have to be done in the dry
- it determines what kind of tolerances in layer thicknesses are acceptable

3.4.6 Maintenance considerations

The considerations given in this respect for river training structures are also applicable here.

3.4.7 Requirements to be fulfilled by the revetment layer

The functional requirements are in the case of canals not always limited to current and wave attack, vandal proof and geotechnical stability of slope and toe, but may also comprise limited hydraulic roughness, and water tightness. On the other hand, water-level variations might be less critical in canals.

Table 8 Possible causes of failure

Bank instability
Toe scour
Transition between parts or systems over topping
excessive movement of armour under current attack
excessive movement of armour under wave attack
settlement
loss of sub layer material through armour
loss of subsoil through geotextile filter
loss of grouting or binder materials
deterioration of geotextile filters
failure of cables
failure of pins or other connections
abrasion
corrosion of wire
chemical action
bed lowering by dredging or maintenance
plant growth
cattle
vandalism

3.5 Structure-specific design aspects

Much of what has been said in section 2.5 on structure-specific design aspects of river training structures is also valid for slope/bed protection of canals. Main points of difference are the hydraulic loads (i.e. in navigation canals) and the fact that protection in navigation canals is normally limited to a revetment layer on the slope in the zone of current/wave attack. Typical solutions for slope protection are shown in Figure 26. For the design of bed protection in all canals and of slope protection in water conveyance canals the design steps are similar to those presented in section 2.5.1, though toe stability (step 3) is normally not critical in water conveyance canals. The main difference is in the design of slope protection for navigation canals which has to take into account ship-induced loads.

Assuming for the sake of clarity that only these loads are present in a particular case, the designer has to calculate values for the following hydraulic loads:

- depression in water level near the slope during passage of ship(s)
- return current during passage of ship(s)
- transversal stern wave: wave height, average head difference, maximum head difference, max. current velocity
- secondary ship waves
- current velocities due to propeller thrust caused by manoeuvring and sailing ships

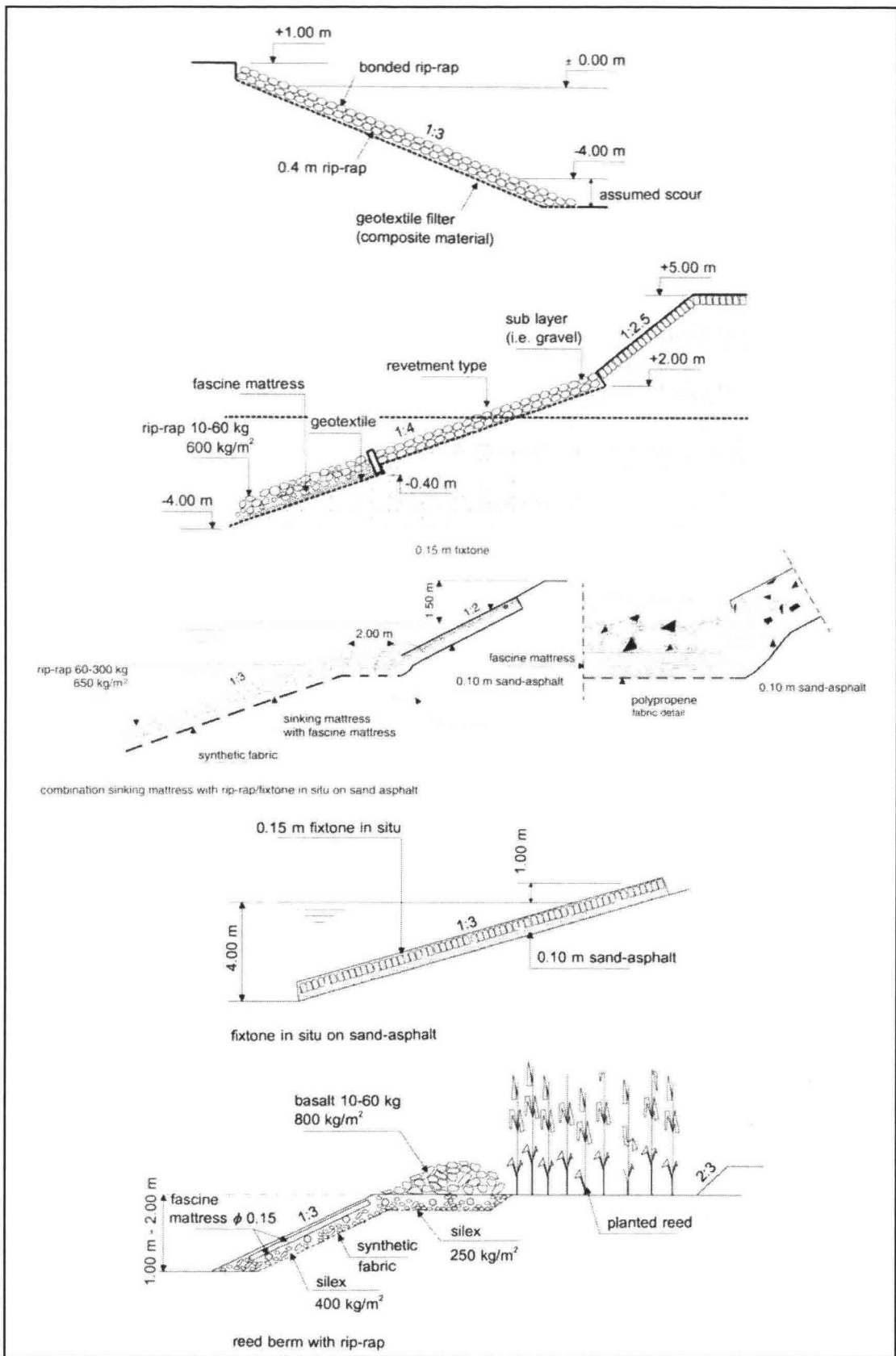

Figure 26 Solutions for slope protection works in navigation channels

3.6 Example design of slope protection in navigation canal

3.6.1 Background and data

An old navigation canal will be upgraded to accommodate Class V vessels (large motor vessel acc. to ECMT classification, see PIANC, 1987). The upgrading mainly concerns the construction of revetments on the slopes as well as bed protection (if required). Slopes and canal bed are at present covered by a 1 m thick layer of clay. The design of slope and bed protection are demonstrated in this Section, using the formulae given in Sections 4.2.7 (Figure 4.71) and 5.2.6. of the Manual on the use of Rock in Hydraulic Engineering (CUR 169). Cross-sectional profiles of the canal and the vessel are shown in **Error! Reference source not found.** from which the most important data can be listed as follows:

Table 9 Primary design data of canal, vessel and sailing course

symbol	description of parameter	value
Ac	overall wet canal profile	225 m ²
m	side slope of canal, $m = \text{tga}$	1:3
h	depth of canal	5 m
bw	width of canal at the water surface	60 m
bb	width of canal bottom	30 m
Am	maximum wet cross section of ship (loaded)	34.5 m ²
Ls	length of ship	110 m
bs	width of ship	11.5 m
y	distance of ship axis from channel axis	10 m
ys	distance at the water surface between side of ship and canal side slope ($= 1/2 bw - 1/2 bs - y$)	14 m
Ls	length of ship	110 m
Ts	draught of ship (loaded)	3 m
	idem, unloaded	1.7 m
P	applied power of ship screw	2000 kW

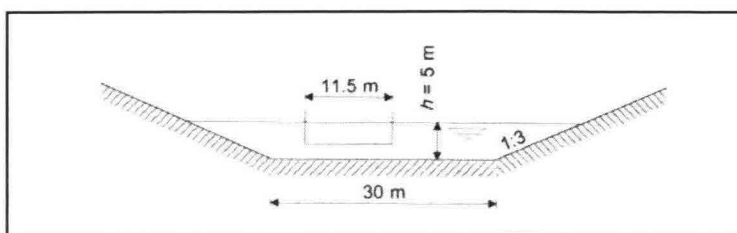

Figure 27 Cross-sections of canal and vessel

3.6.2 Determination of cover layer on slopes

As it concerns an existing canal which cannot be set dry, the only feasible slope protection is one of rock, dumped on a geotextile. In Figure 28 the principle zones in

which various hydraulic loads are effective are indicated. In this Sub-Section, the stone sizes are calculated for two loading cases and subsequently, zoning and layer thickness are determined.

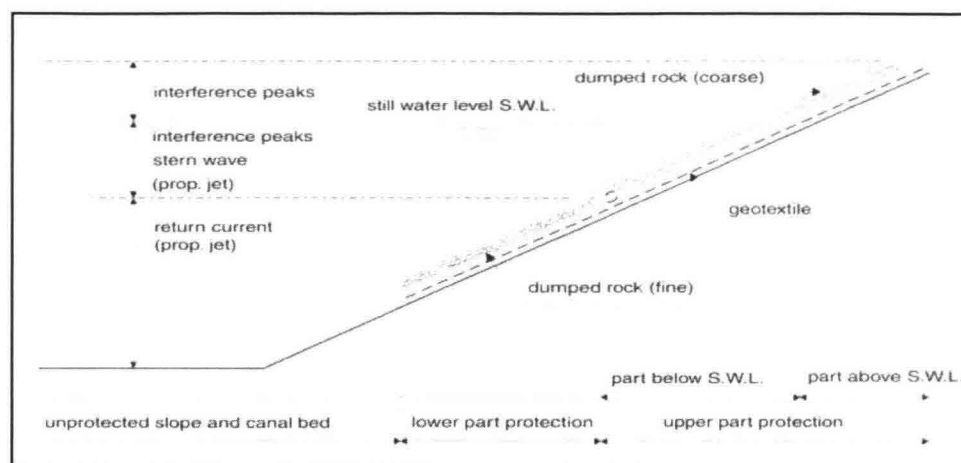

Figure 28 Zoning for slope protection

4 SPECIAL STRUCTURES

4.1 General

In the Introduction to this Chapter as special structures were mentioned bed/scour/bank protection works associated with:

- pipeline and cable crossings
- fish sluices
- anchoring structures
- bridge piers
- jetties

As such, the design of these and similar other structures is outside the scope of this Manual. However, their presence in rivers or canals may have an impact on water levels, current velocities, scour and on the structures discussed in Chapters 2 and 3. This statement requires some clarification:

Water levels can be influenced by pipe line and cable crossings if these structures start to form a sill in the river or canal. This can happen if these structures are either covered by a thick layer of stone (placed to avoid damage of crossings by anchors or placed in order to ballast the pipeline) or in case of river bed degradation. If at all possible these structures should be placed in a dredged trench backfilled with sand. If a layer of rock is considered necessary for protection against anchoring then its top level should be low enough to stay below any future bed degradation.

Current velocities may locally be increased by any of the structures mentioned but mostly such increase is modest. Exceptions are bridge piers and anchoring structures. Because of their massive profile perpendicular to the current direction the increase in currents around the structures can be considerable. This in turn may result in local scour

unless a bed protection around the structure is introduced. The latter is a good solution if -apart from the said local scour- no other types of scour have to be expected. The designer must consider the following two alternatives:

- no bed protection, resulting in scour and consequently, a deeper foundation level for pier and/or piles, a larger “free-standing” height and larger ships impact on pier/pile combination;
- bed protection, which not only has to prevent local scour, but shall also be able to counter-act (e.g. by means of a falling apron) any other type of scour at some distance from the pier/pile group and subsequent geotechnical instability (e.g. liquefaction due to earthquakes).

Impact on river training and waterway slope protection structures: reference is made to Sub-Section 2.5.4.