

A 3D wireframe model of a city street scene, rendered in a dark blue and orange color scheme. The buildings are shown as transparent wireframes, and several solar panels are mounted on the roofs. The scene is illuminated from the left, creating a warm, orange glow. The text is overlaid on the right side of the image.

Towards Solar Irradiation Prediction on 3D Urban Geometry using Deep Neural Networks

Job de Vogel / 03 September 2024

Main mentor: dr. ir. Michela Turrin
Second mentor: dr. ir. Seyran Khademi

Graduation committee member: Prof.dr.ir. M.G. Elsinga



The design software of the future

Architect Design

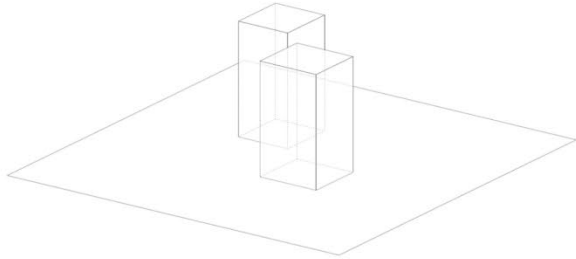

AI Solar Prediction

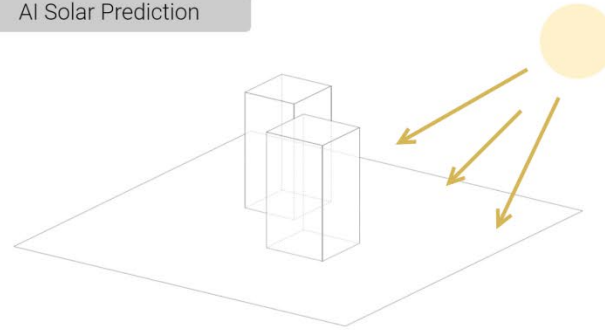

Description

Amazing, impressive, school, building, artistic, colored, highly detailed, moder, traditional, classic etc.

AI Wind prediction

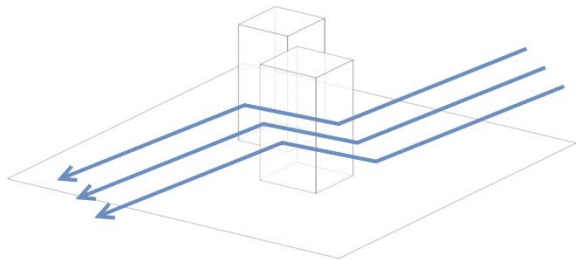

AI Design Suggestions

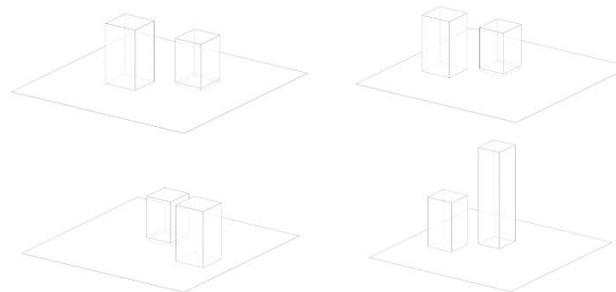

Requirements

Floor area
Solar panel power
Shadow
Function
etc.

How can one predict annual solar irradiation on 3D urban geometry using Deep Neural Networks?

How can one predict annual **solar irradiation** on 3D urban geometry using Deep Neural Networks?

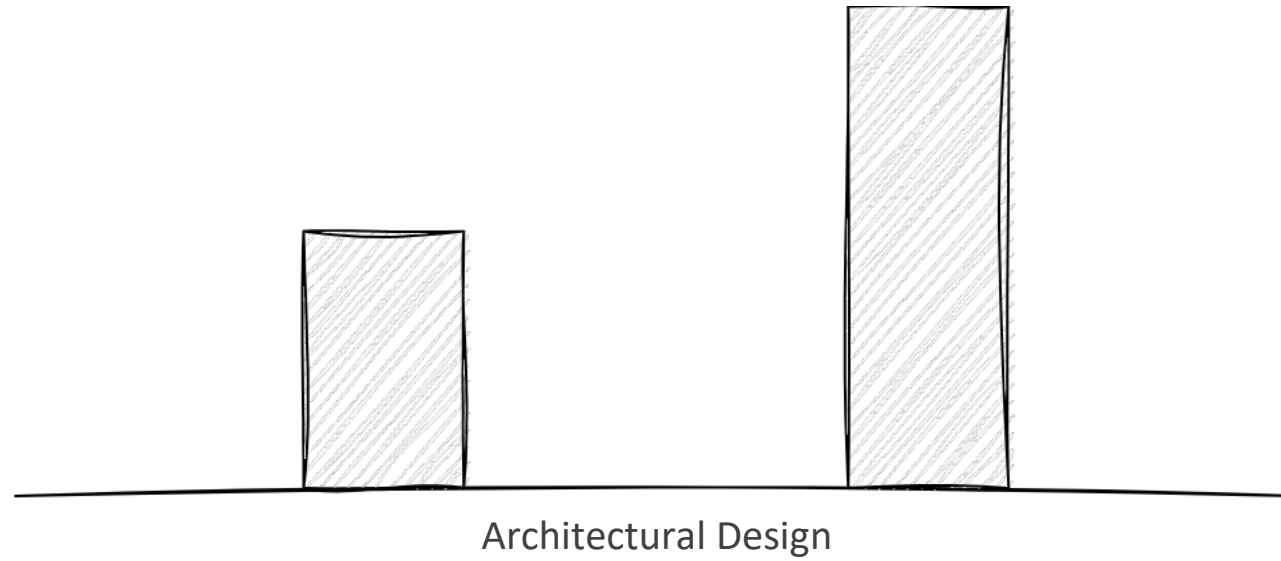

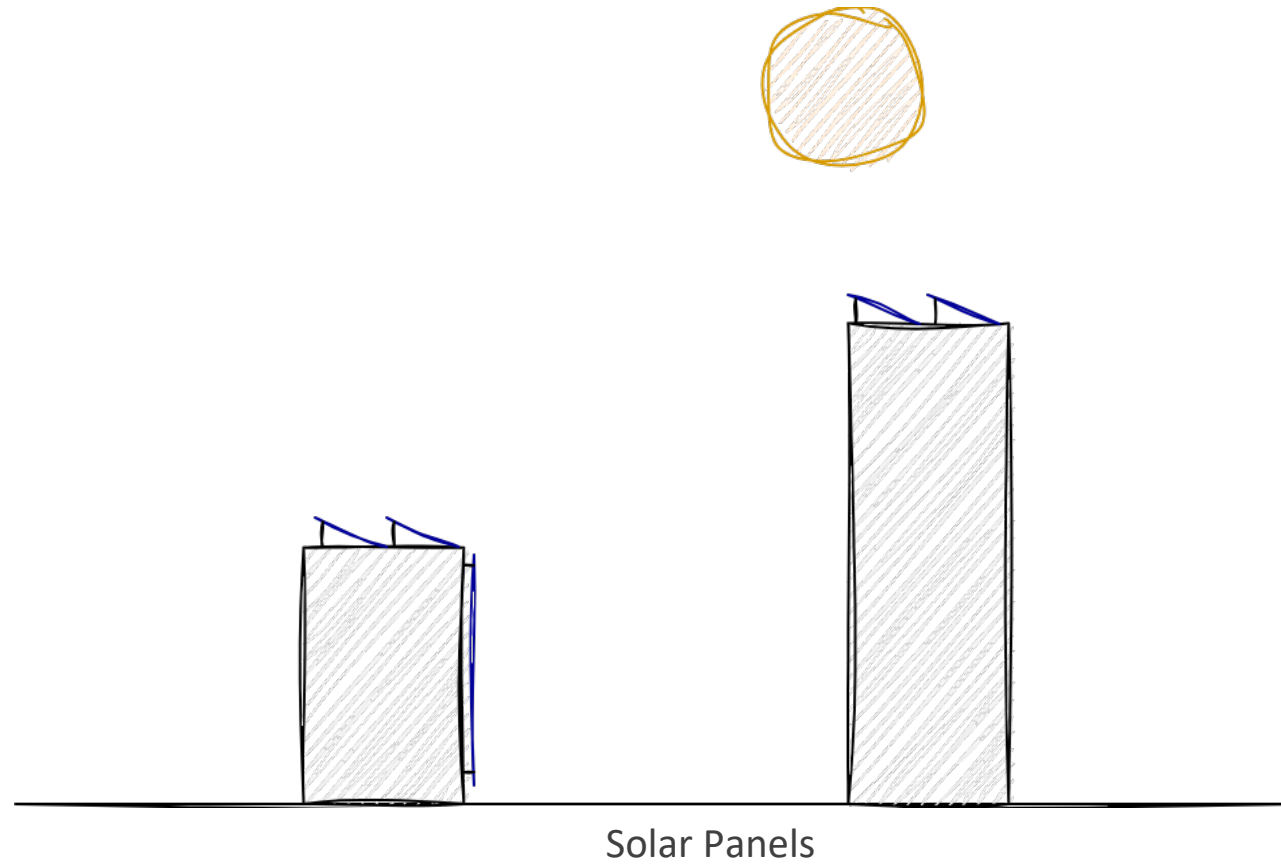

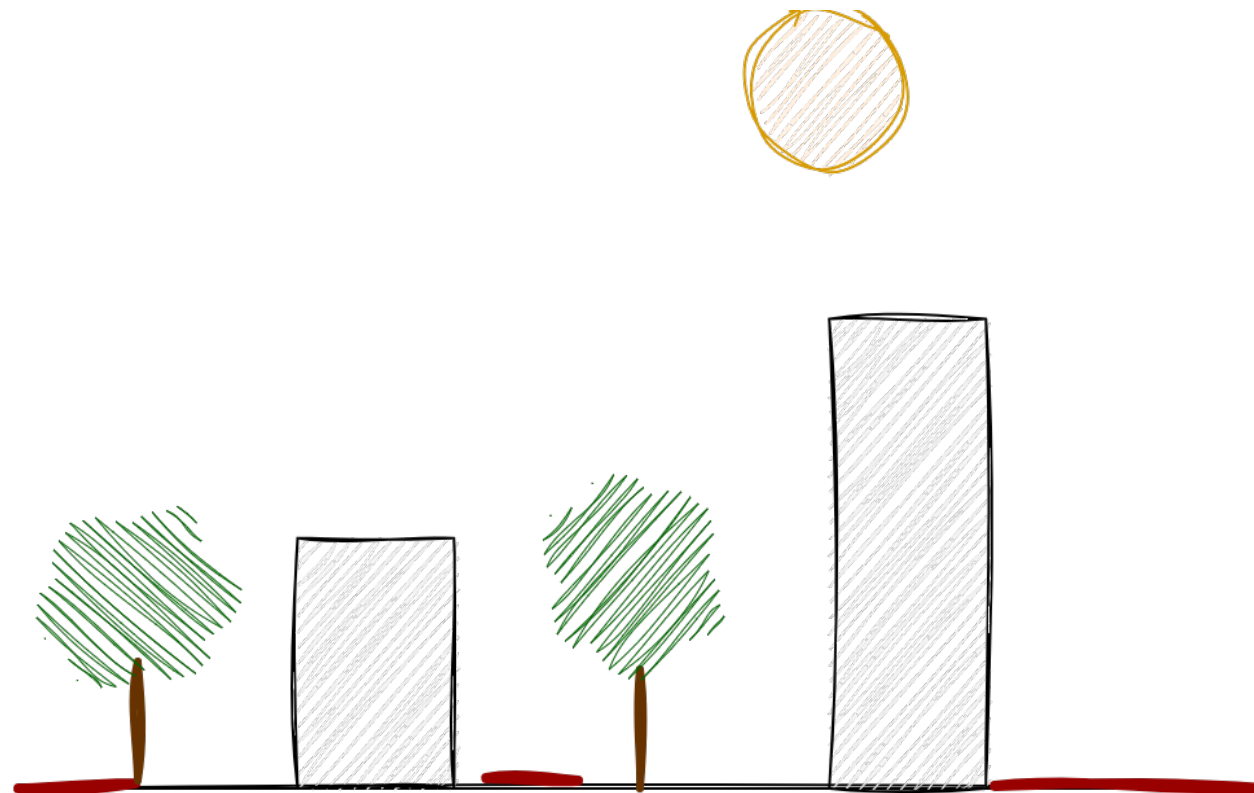

Urban Heat Effect

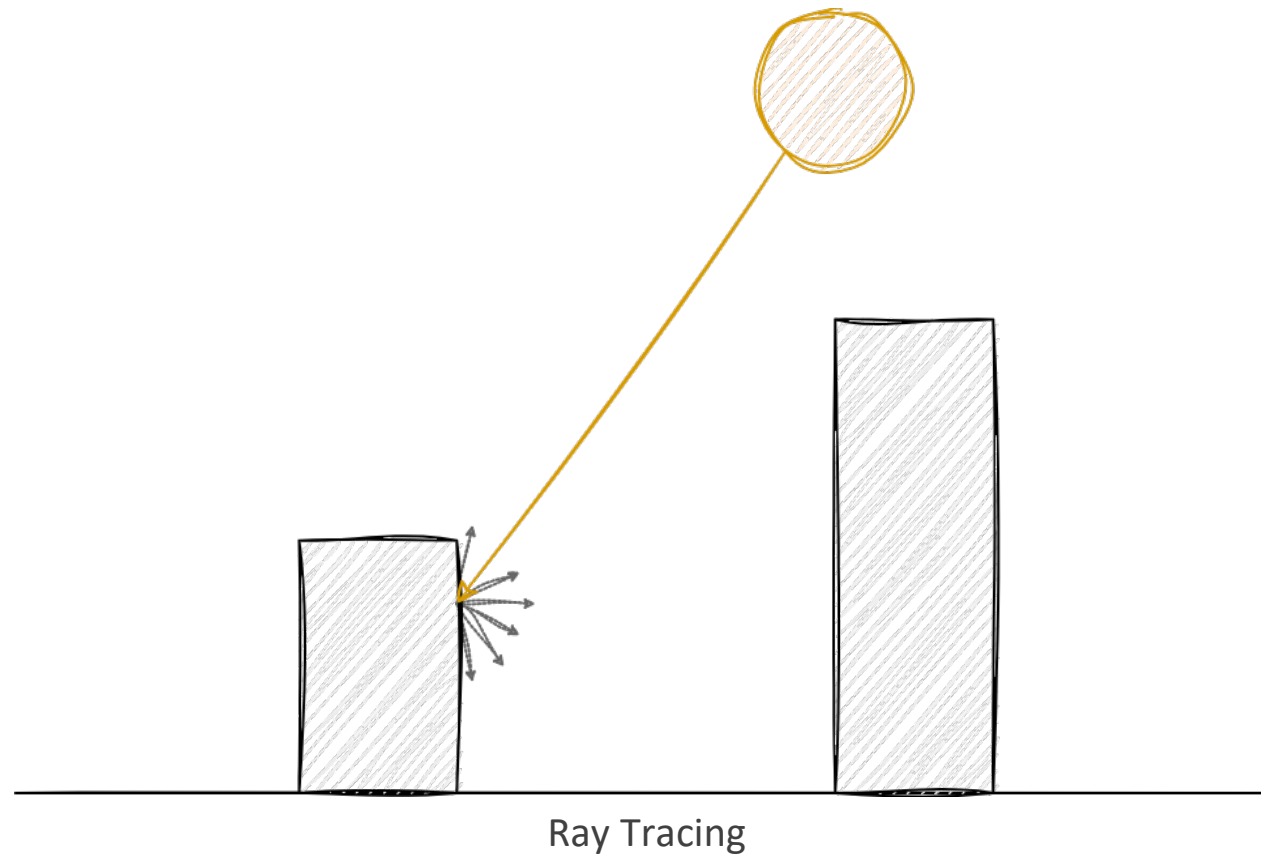

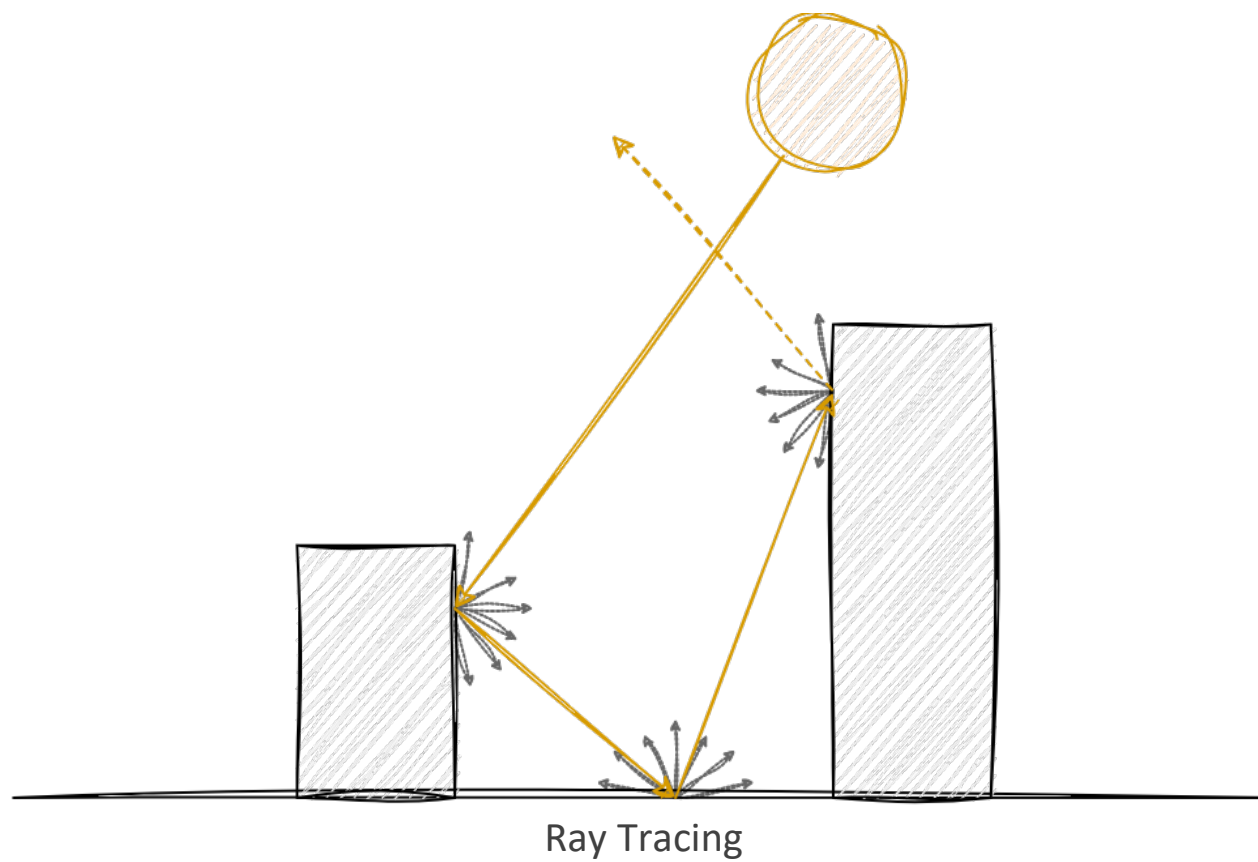

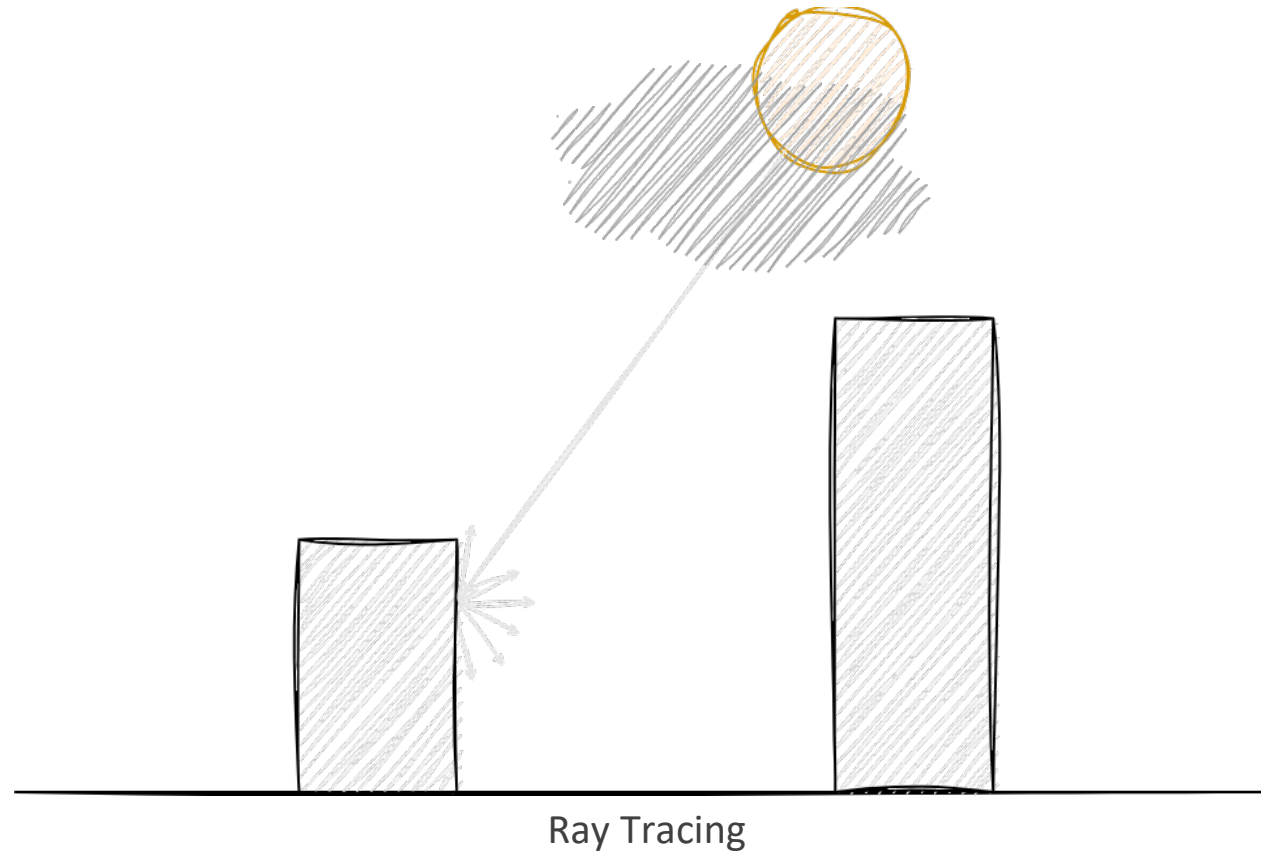

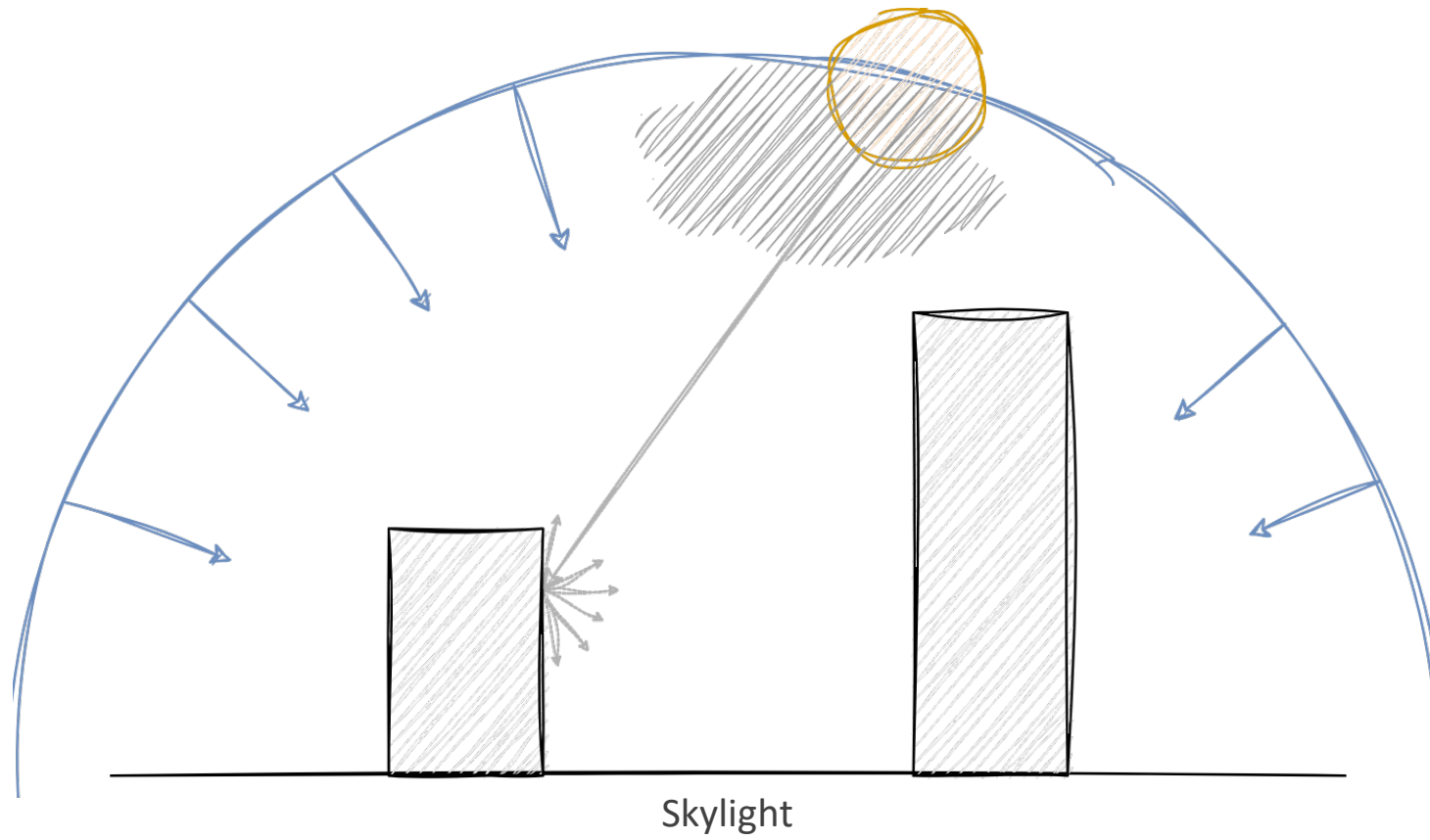

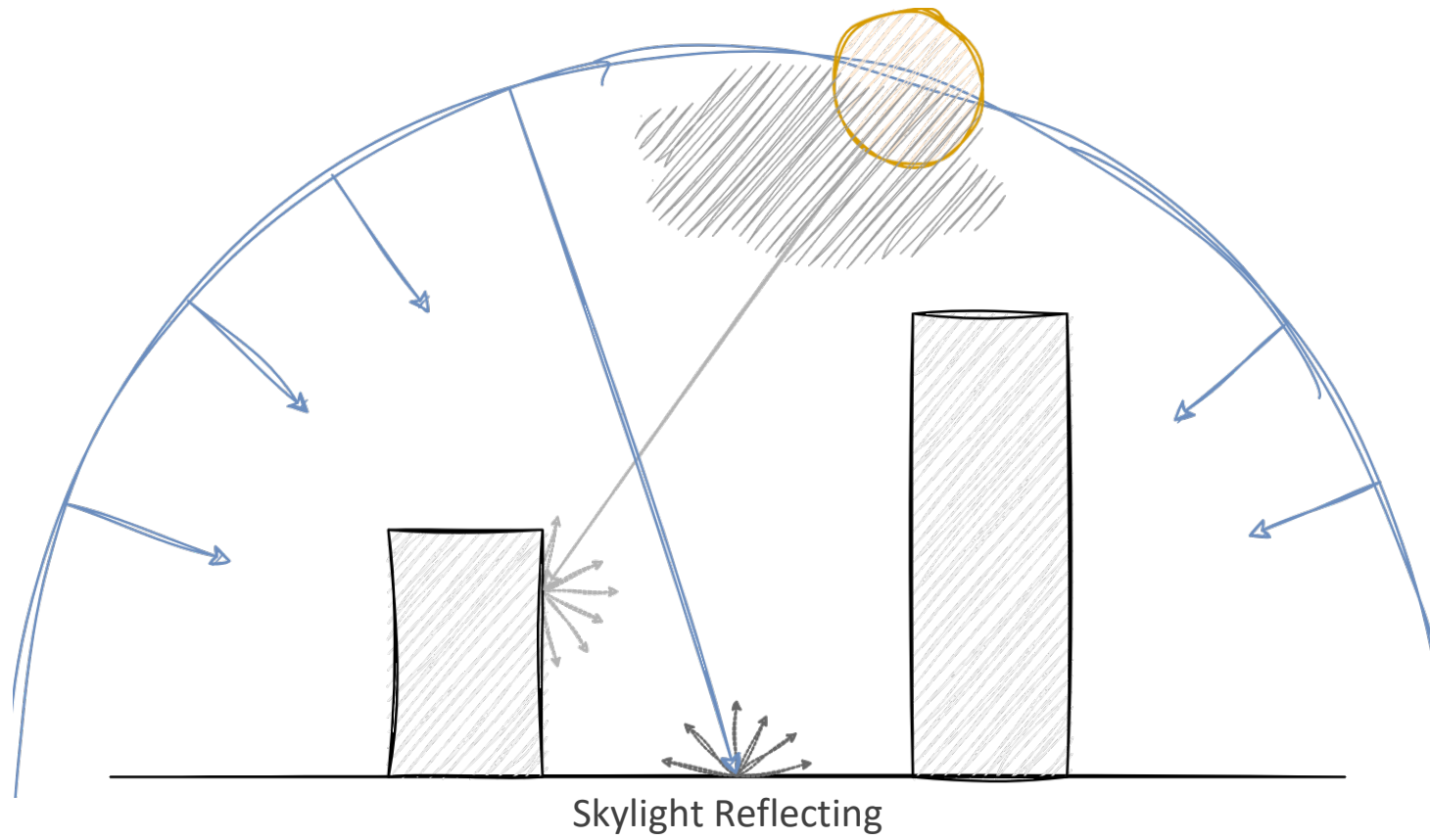

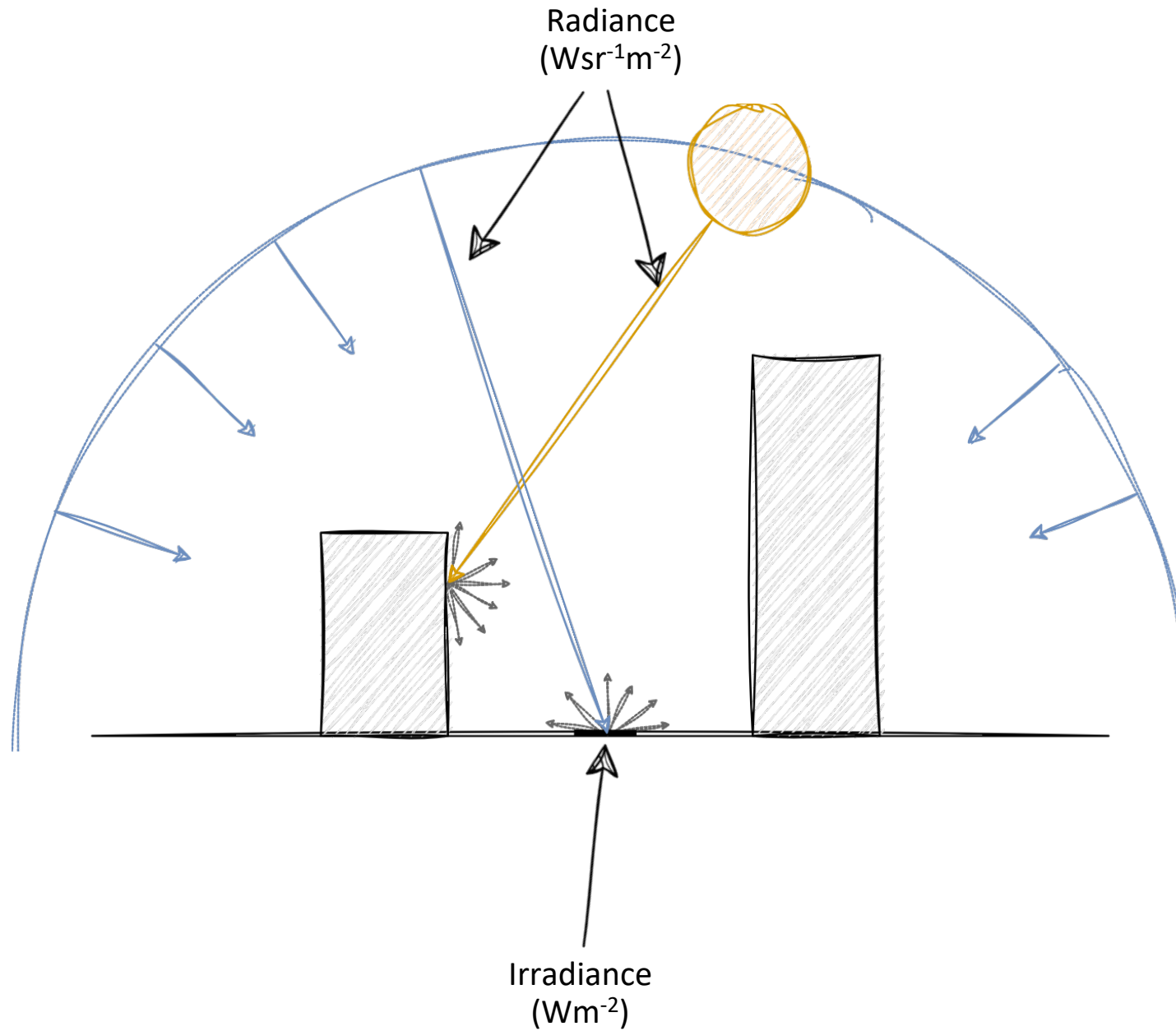

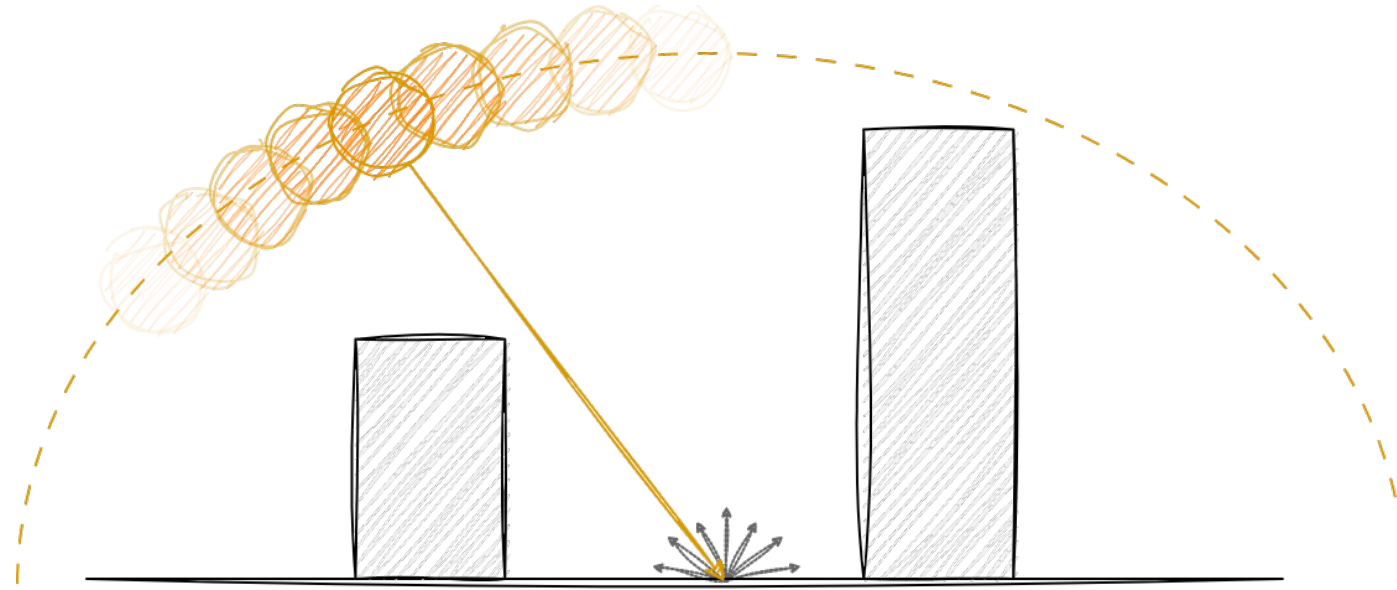

Solar Irradiation
(kWh/m²)

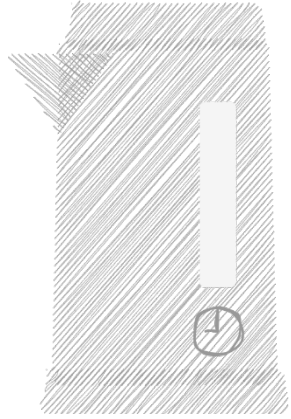

1 hour of kettle usage

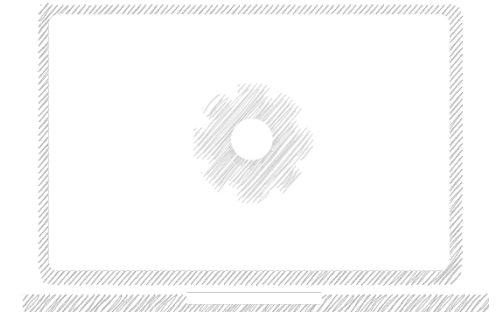
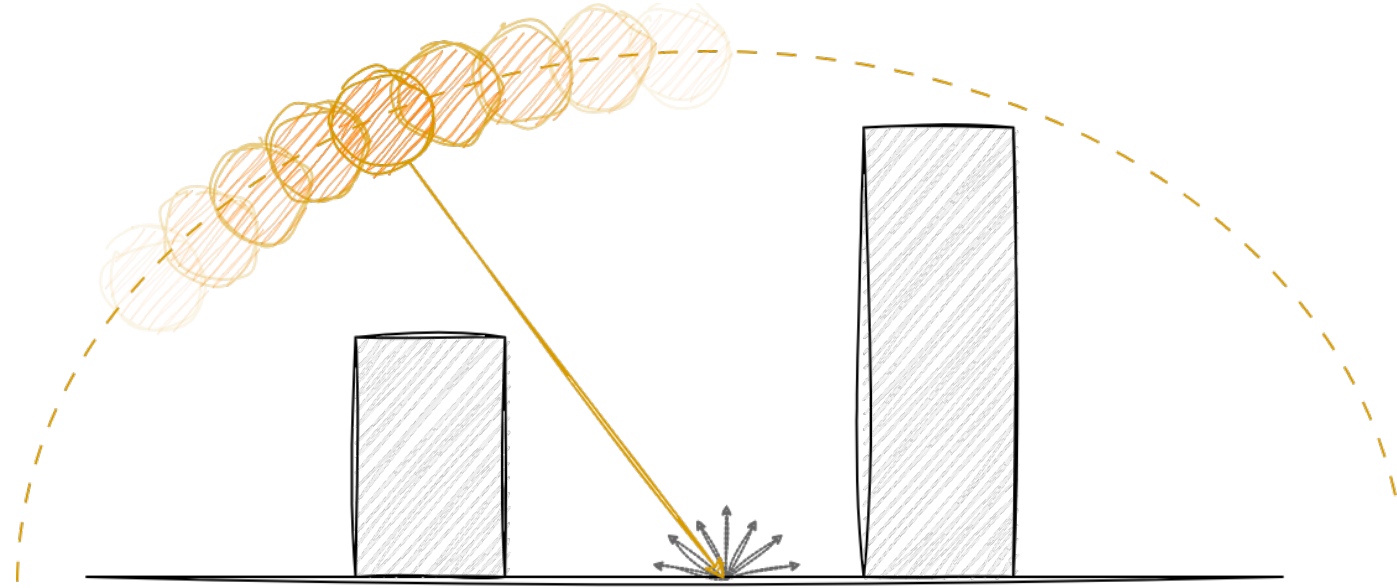

8 hours of laptop usage

Solar Irradiation
(kWh/m²)

Simulation



AI Prediction

Emitted light by point

Reflectance-transmittance ratio

$$L_r(\theta_r, \phi_r) = L_e + \iint L_i(\theta_i, \phi_i) f_r(\theta_i, \phi_i, \theta_r, \phi_r) |\cos \theta_i| \sin \theta_i d\theta_i d\phi$$

Reflected light from point
Into direction (θ_r, ϕ_r)

Incoming direct and indirect
light

All directions

$$E_{dir} = \int L_{dir}(\theta_i, \phi_i) \cos \theta_i \sin \theta_i d\omega_i$$

$$E_{ind} = \iint L_{ind}(\theta_i, \phi_i) \cos \theta_i \sin \theta_i d\theta_i d\phi_i$$

$$E = \left(\frac{\pi}{M \cdot N} \right) \sum_{j=0}^{M-1} \sum_{k=0}^{N-1} L_{j,k}$$

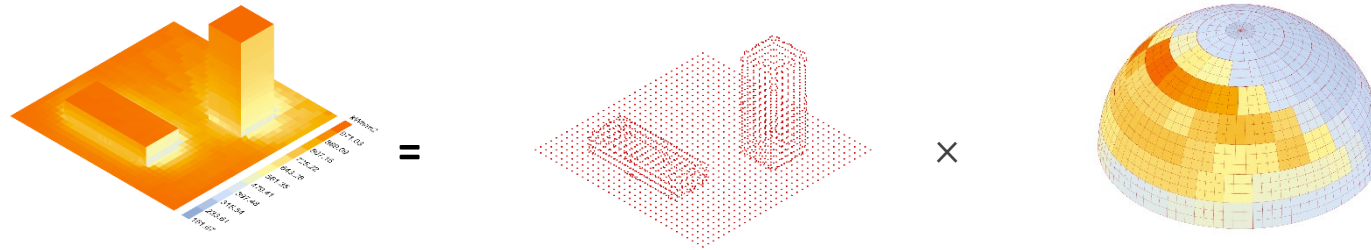

$$\begin{bmatrix} E_1 \\ E_2 \\ \vdots \\ E_m \end{bmatrix} = \begin{bmatrix} D_{11} & D_{12} & \dots & D_{1n} \\ D_{21} & D_{22} & \dots & D_{2n} \\ \vdots & \vdots & \dots & \vdots \\ D_{m1} & D_{m2} & \dots & D_{mn} \end{bmatrix} \times \begin{bmatrix} S_1 & L_1 \\ S_2 & L_2 \\ \vdots & \vdots \\ S_n & L_n \end{bmatrix}$$

$$\text{Irradiation}_{\text{sensorpoint}} = [\text{Daylight Coefficients}] \times [\text{Angular Size} \cdot \text{Radiance}]$$

Author	Year	Name	Dataset	Input	Model	Prediction Type
Alammar A. et al.	2021	N/A	Surrogate envelopes	Categorical	ANN & Random Forest	Single façade patch
Lila A. et al.	2021	N/A	Surrogate envelopes	Categorical	ANN	Single roof
Tehrani et al.	2024	N/A	GIS data	Categorical	ANN	Average Cumulative Radiation
Yue et al.	2024	N/A	GIS data Zhengzhou	Categorical	17 common models	Cumulative Radiation by surface orientation
Galanos T. & Chronis A.	2022	N/A	GIS data Vienna	Heightmap	GAN	Envelope ground
Huang C. et al.	2022	N/A	Surrogate envelopes	Categorical, heightmap	CycleGAN, pix2pix, ANN	Envelope ground
Han J.M. et al.	2022	CoolVox	Surrogate envelopes	3D occupancy grid	3DCNN	Facade and roof of single building
Nakhaee A. et al.	2023	Deep-Radiation	GIS data New York	Sem. segm. And depth-map fish-eye perspective	GAN with pix2px generator	Envelope ground
Zhang Y. et al.	2023	SolarGAN	GIS data Zurich and Singapore	Fish-eye perspective and location	GAN with VAE generator and more	Solar Irradiation time series

Table 2.1.: Related research papers solar irradiation prediction.

Limited 3D Solution



Generality



Scalability

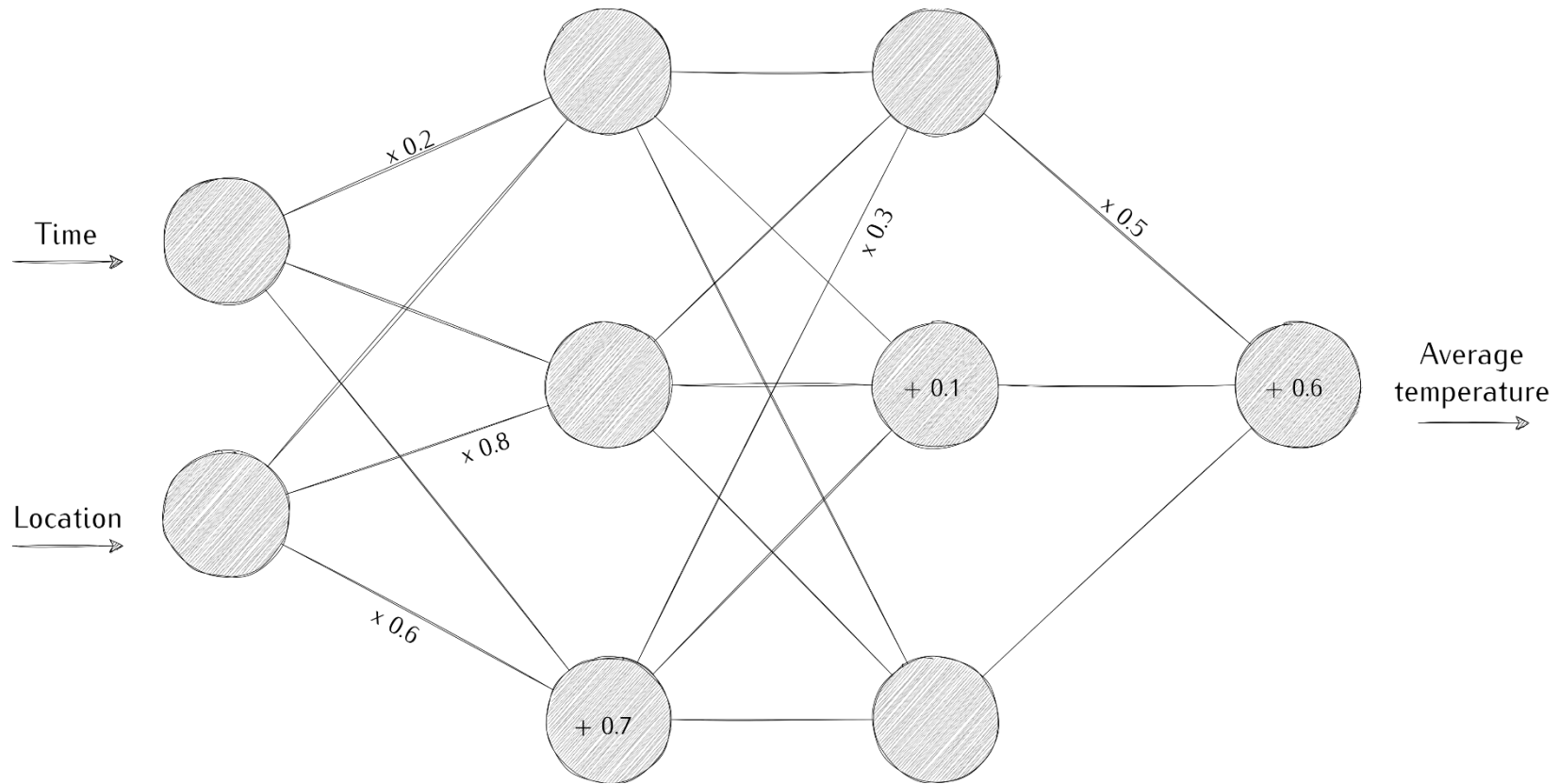

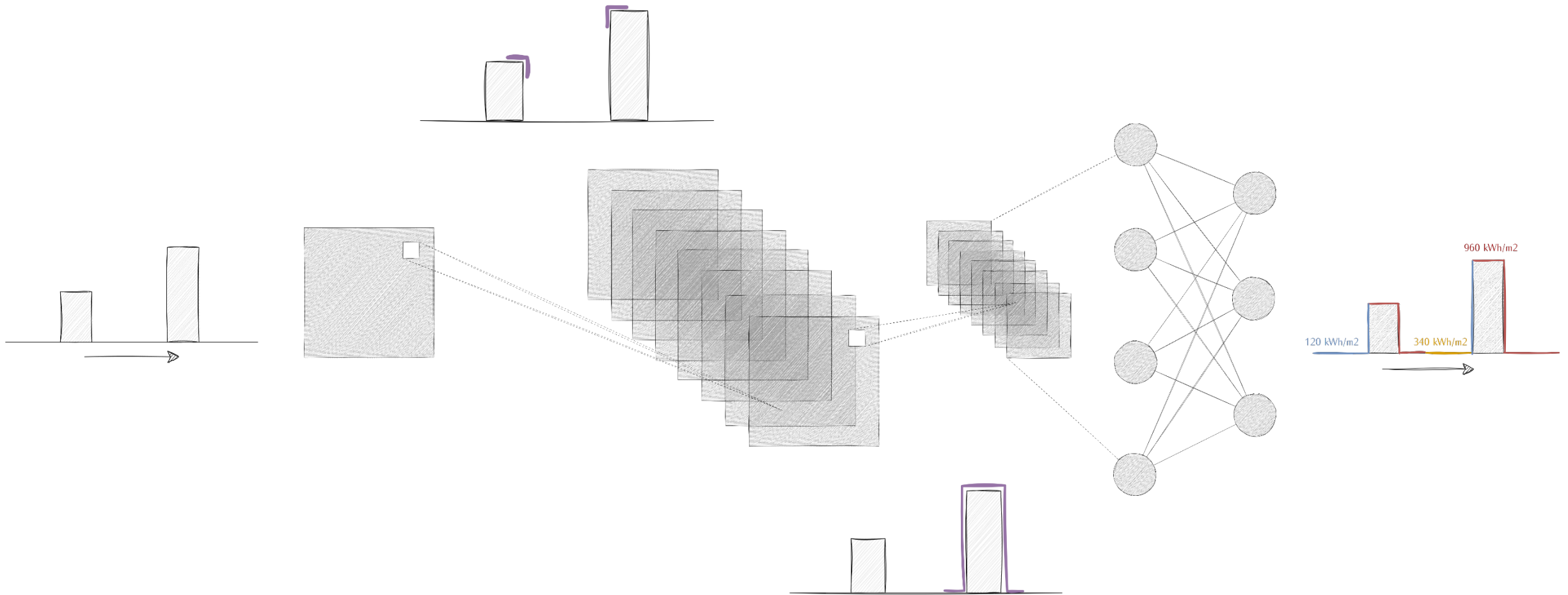

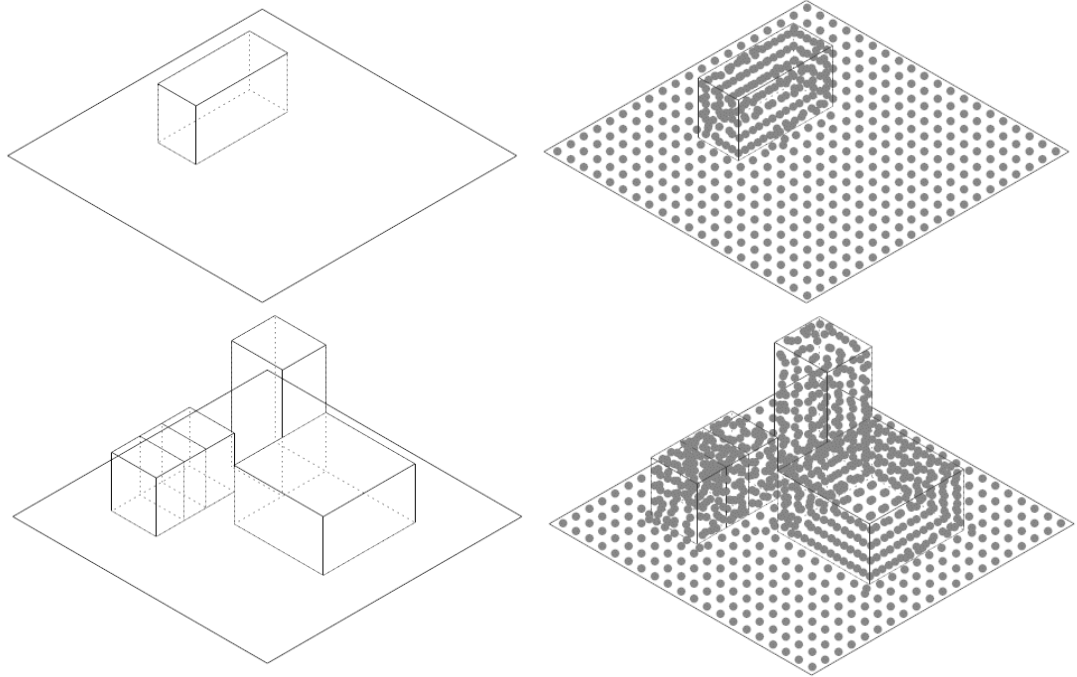

Unknown
Deep Neural Network

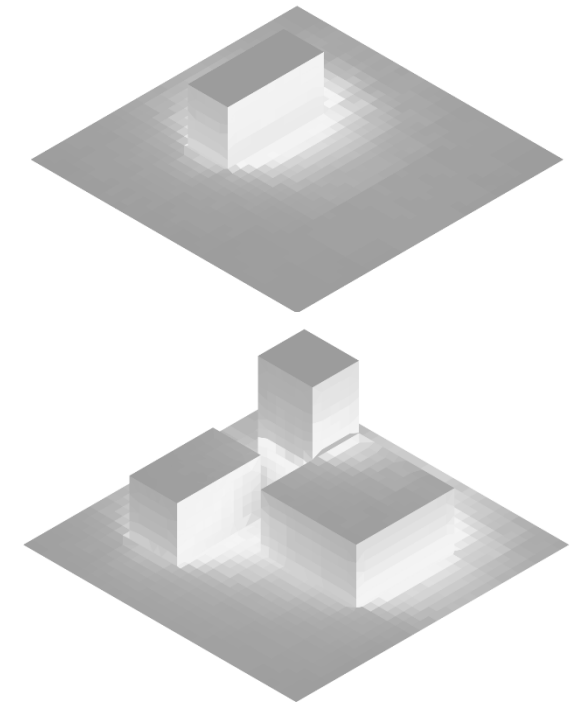

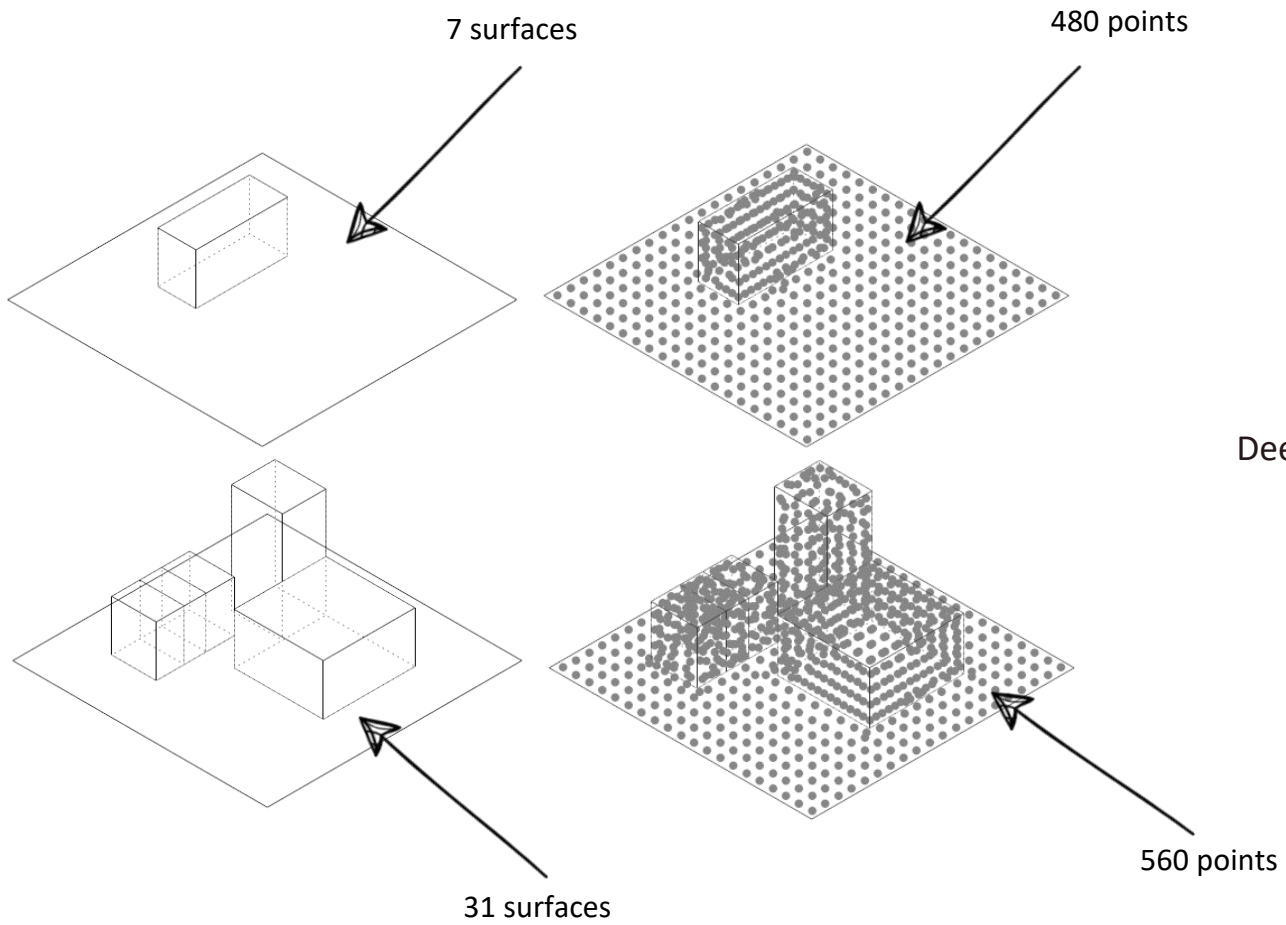

Unknown
Deep Neural Network

● ● ● ●

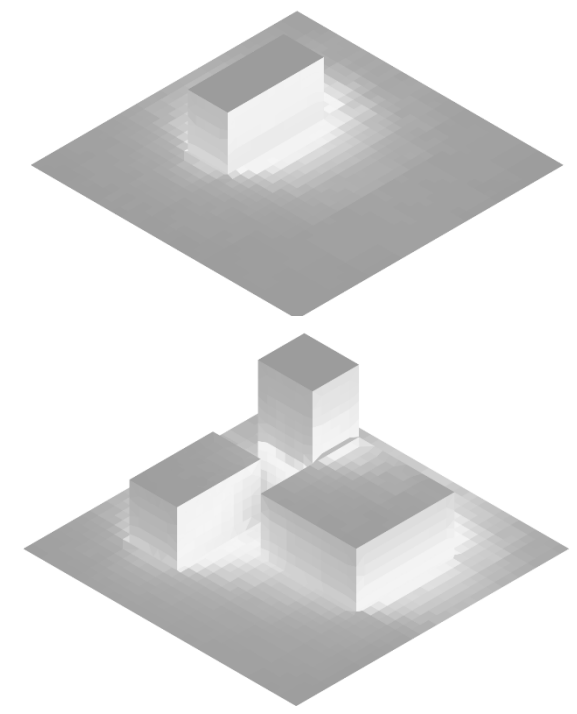

Solutions to irregular 3D data

3D CNN (VoxNET)

Maturana & Scherer (2015)

Octree CNN

Wang et al. (2017)

Mesh CNN

Hanocka (2018)

Multiview CNN

Su et al. (2015)

PointNet

Qi et al. (2016)

PointNeXt based per-point irradiation prediction

PointNeXt: Revisiting PointNet++ with Improved Training and Scaling Strategies
(Qian et al., 2022)

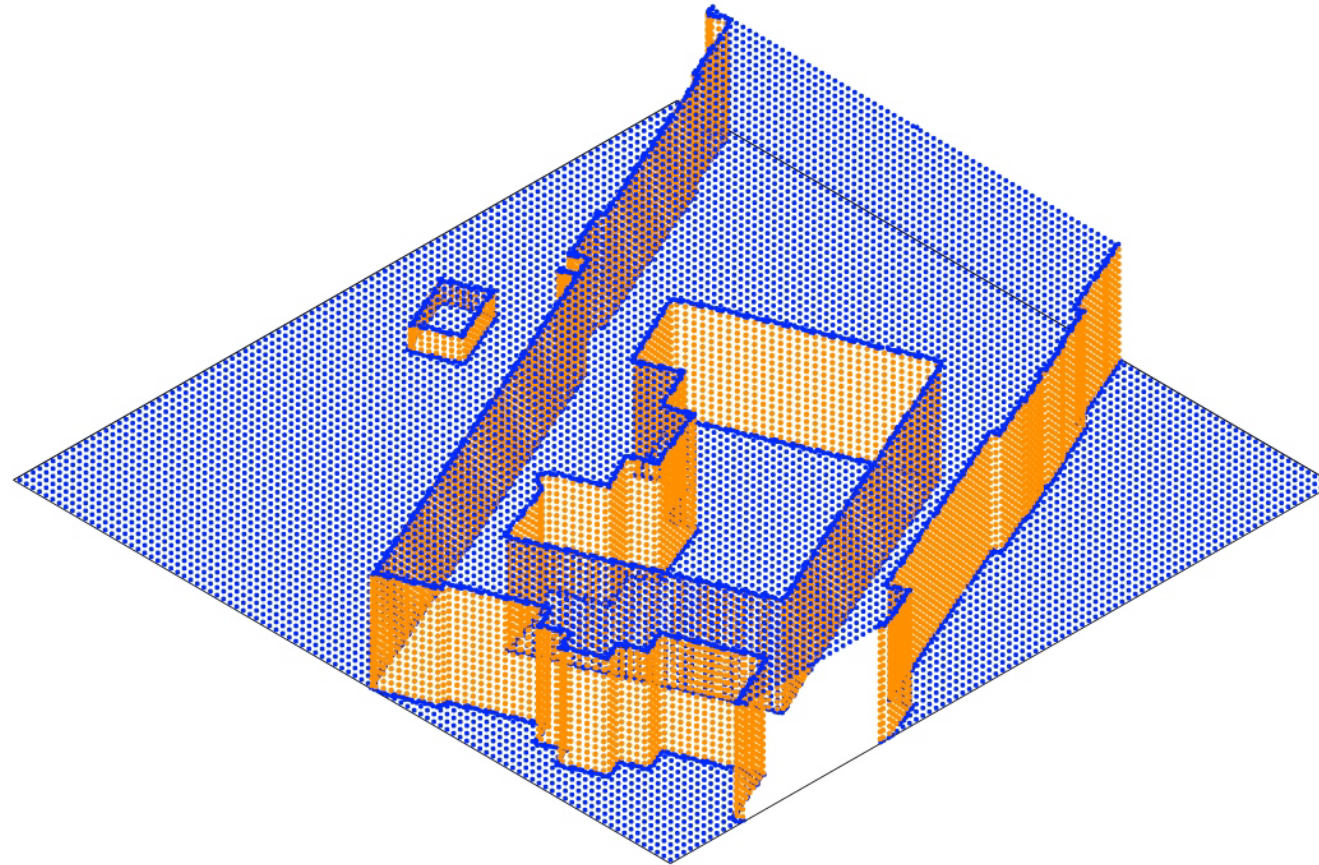

Methods

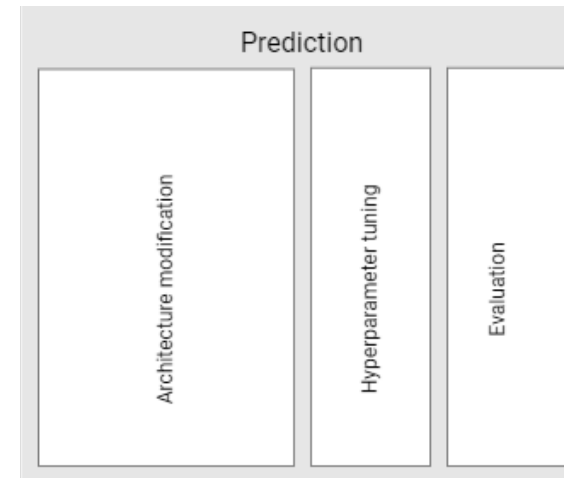
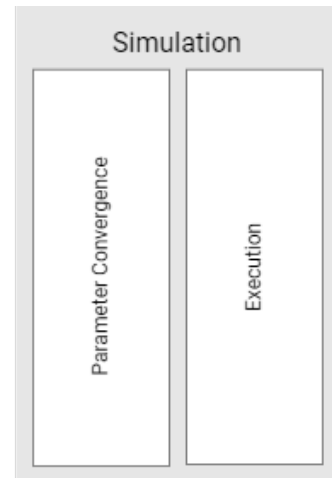
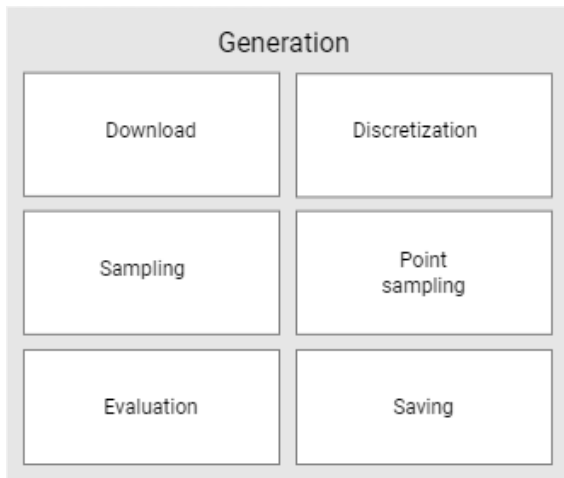

Generation

Generation: Overview

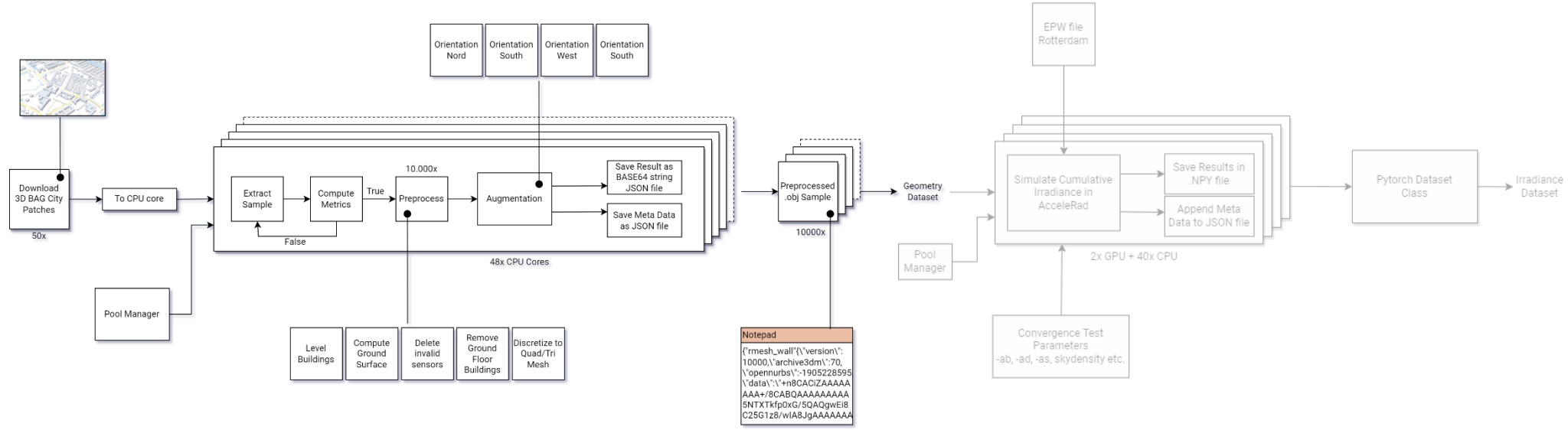

Generation: Download 3D BAG

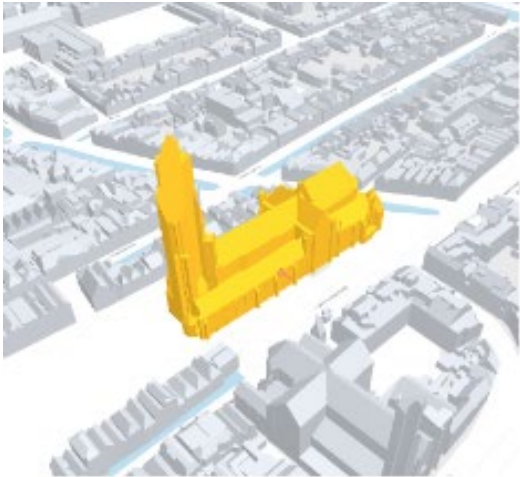
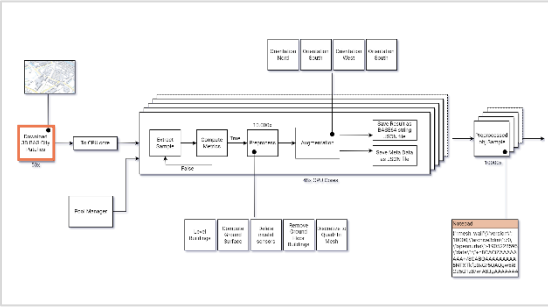

LoD 2.2



LoD 1.3



LoD 1.2

Generation: Download 3D BAG

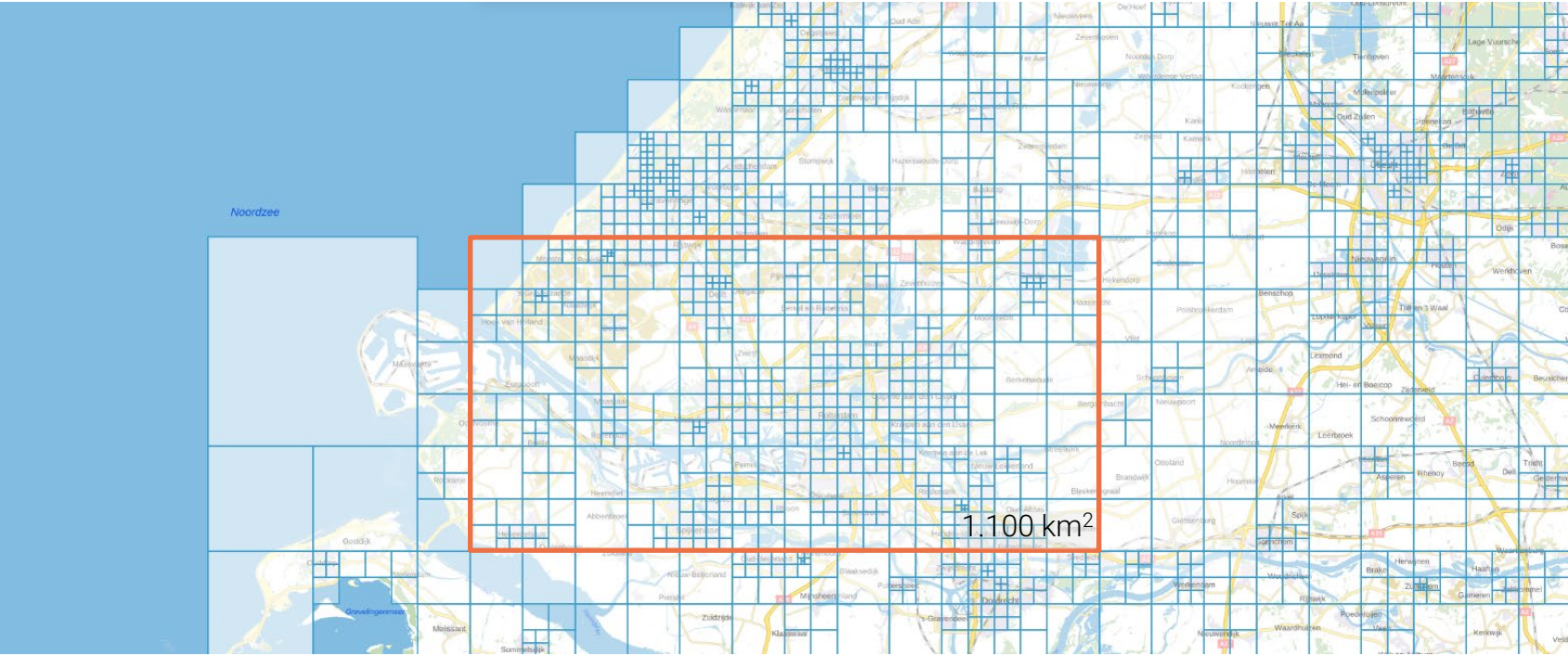
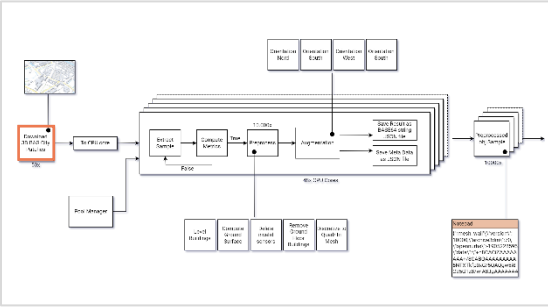

Generation: Sampling

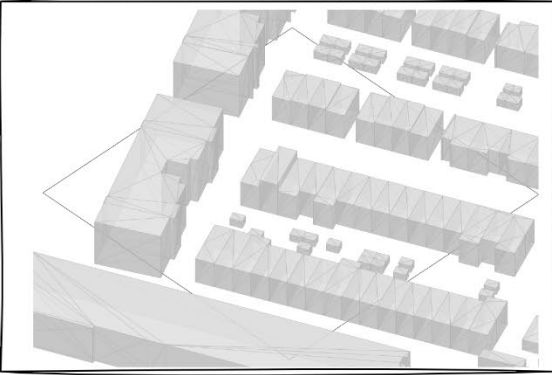
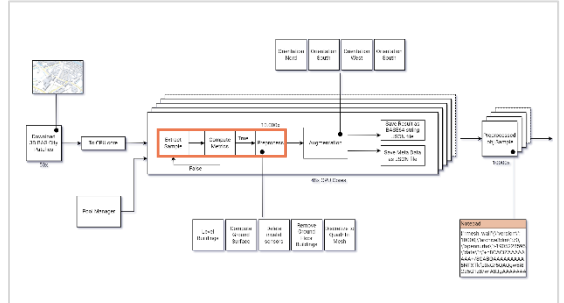

3D BAG Sampling

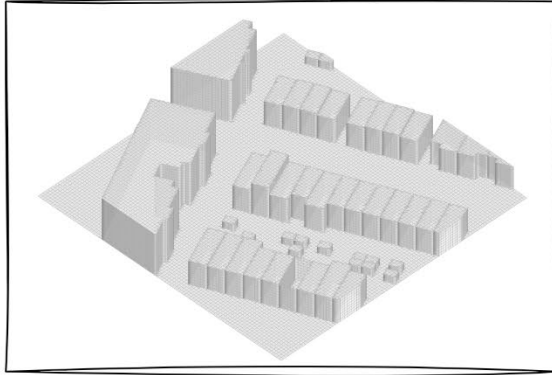

Preprocessing

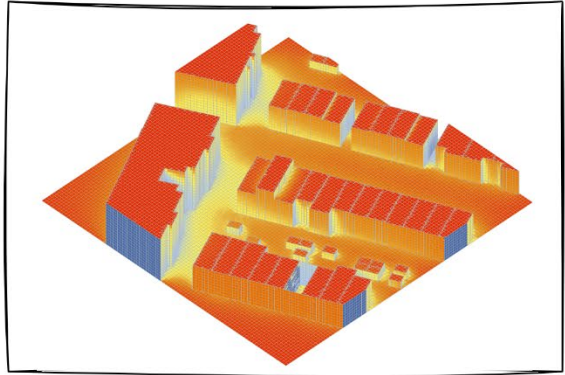

Simulation/Prediction



Generation: Point Sampling

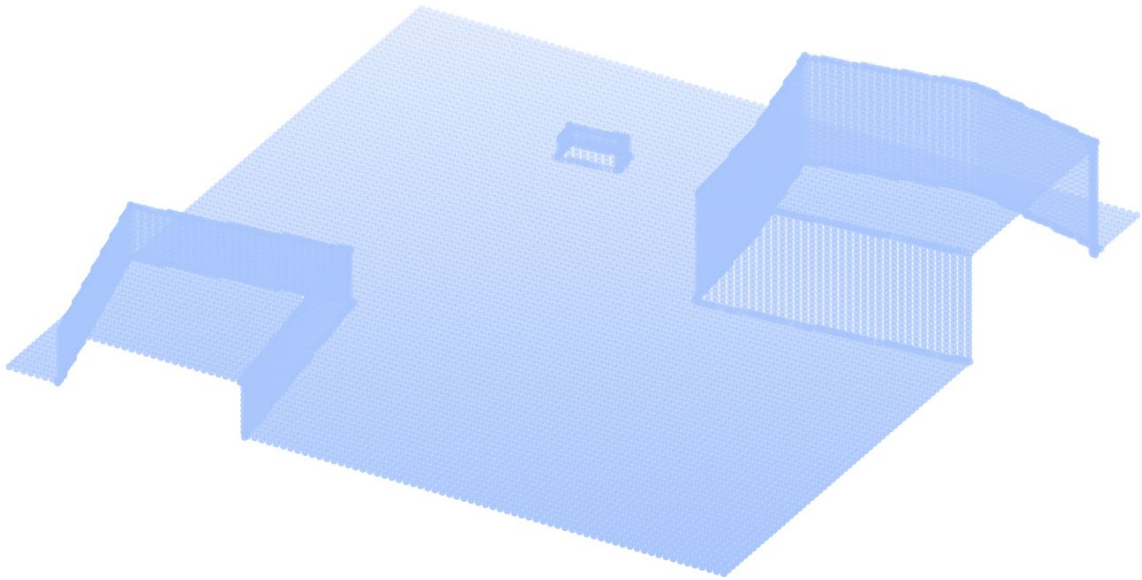
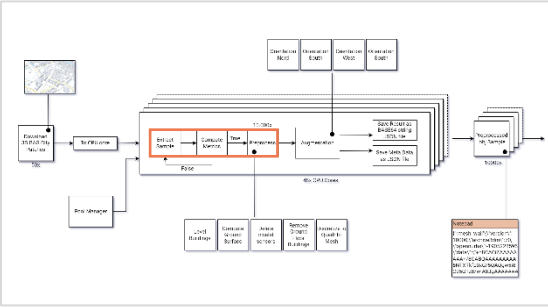

Regular Point Sampling

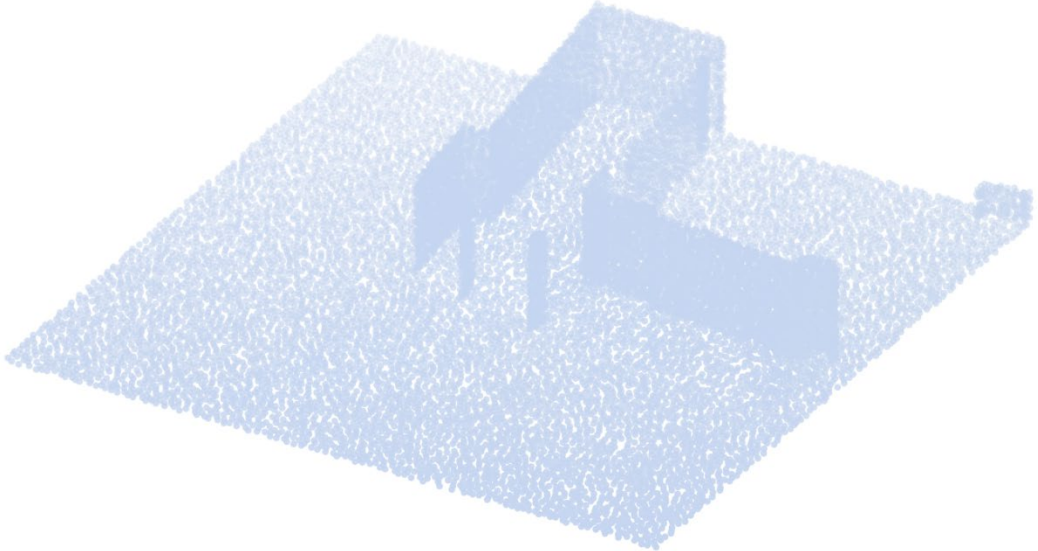

Poisson Disc (Random) Point Sampling



Generation: Format

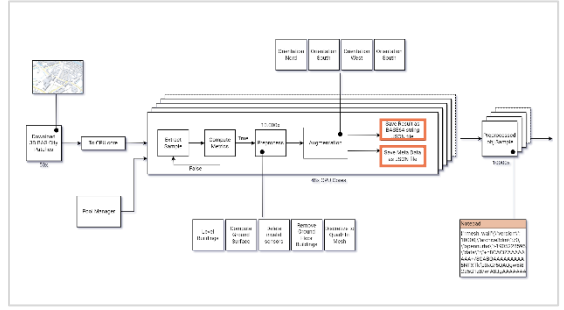

$$\begin{bmatrix}
 x_0 & y_0 & z_0 & u_0 & v_0 & w_0 \\
 \vdots & \vdots & \vdots & \vdots & \vdots & \vdots \\
 \vdots & \vdots & \vdots & \vdots & \vdots & \vdots \\
 \vdots & \vdots & \vdots & \vdots & \vdots & \vdots \\
 \vdots & \vdots & \vdots & \vdots & \vdots & \vdots \\
 \vdots & \vdots & \vdots & \vdots & \vdots & \vdots \\
 \vdots & \vdots & \vdots & \vdots & \vdots & \vdots \\
 x_n & y_n & z_n & u_n & v_n & w_n
 \end{bmatrix}$$

Figure 4.10: $n \times 6$ matrix with x, y, z, and normal u, v, w point cloud data.



Simulation

Simulation: Overview

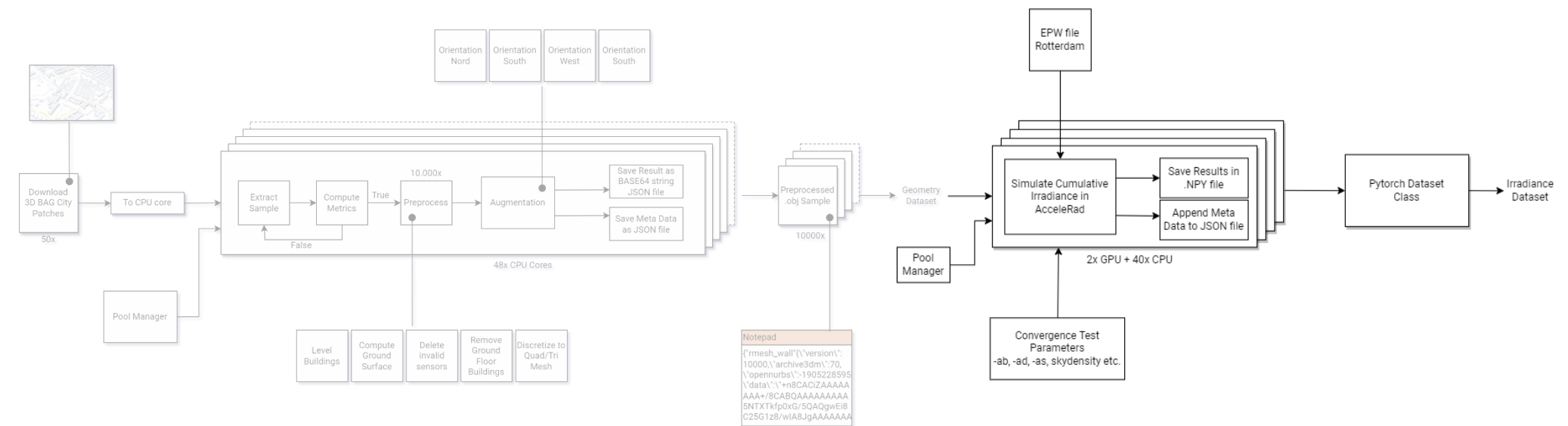

Simulation: Simulator

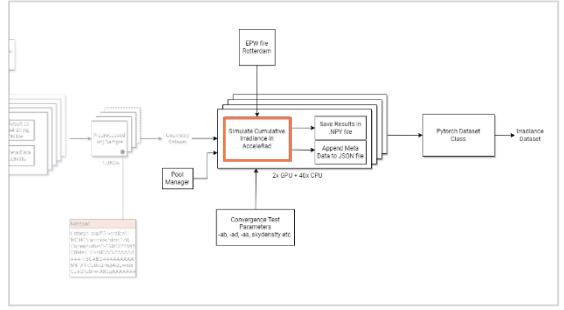
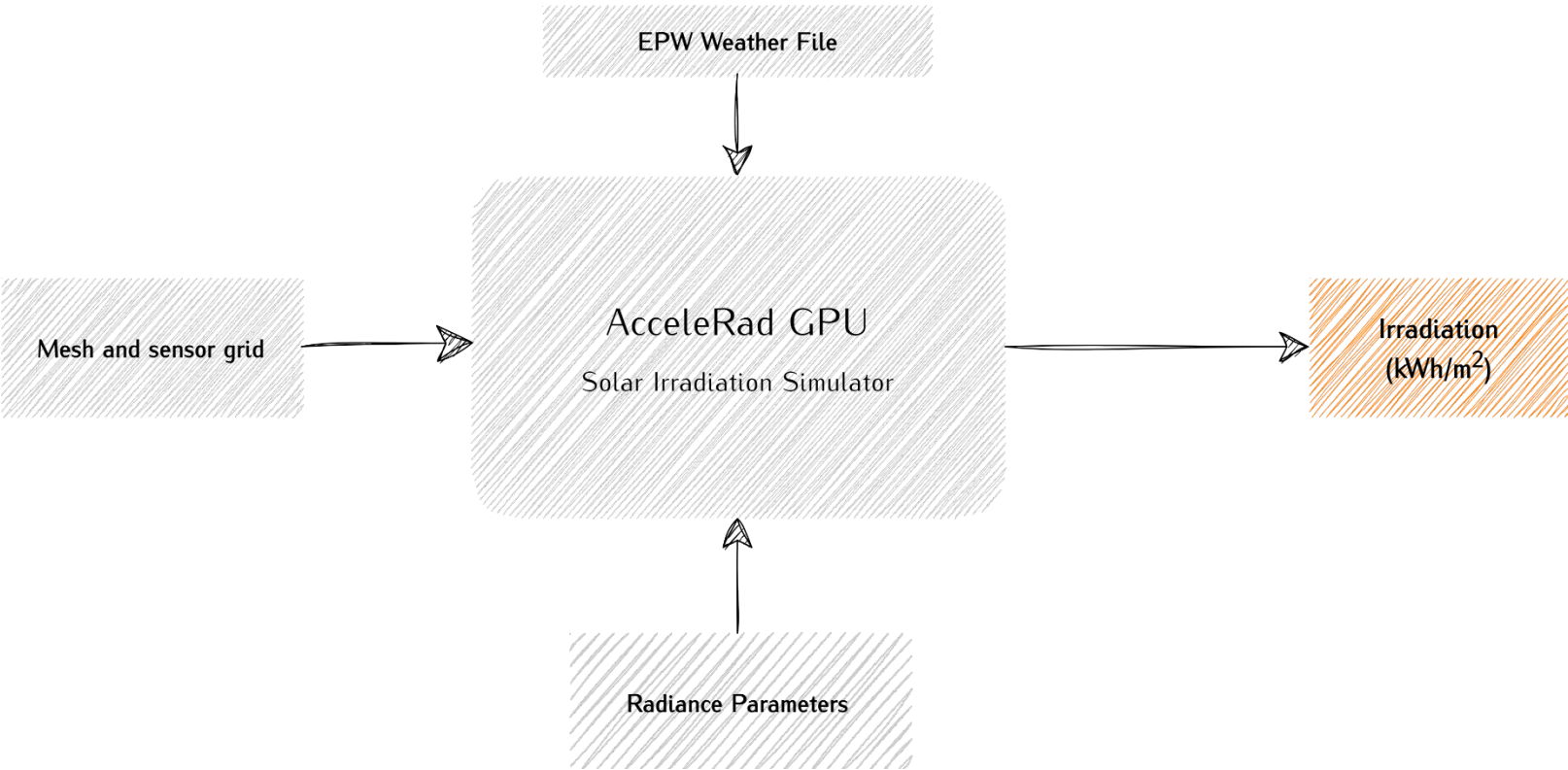

Simulation: Format

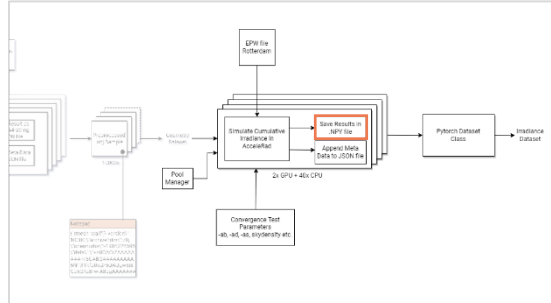

$$\begin{bmatrix}
 x_0 & y_0 & z_0 & u_0 & v_0 & w_0 & E_{i_0} \\
 \vdots & \vdots & \vdots & \vdots & \vdots & \vdots & \vdots \\
 \vdots & \vdots & \vdots & \vdots & \vdots & \vdots & \vdots \\
 \vdots & \vdots & \vdots & \vdots & \vdots & \vdots & \vdots \\
 \vdots & \vdots & \vdots & \vdots & \vdots & \vdots & \vdots \\
 \vdots & \vdots & \vdots & \vdots & \vdots & \vdots & \vdots \\
 \vdots & \vdots & \vdots & \vdots & \vdots & \vdots & \vdots \\
 \vdots & \vdots & \vdots & \vdots & \vdots & \vdots & \vdots \\
 x_n & y_n & z_n & u_n & v_n & w_n & E_{i_n}
 \end{bmatrix}$$

Figure 4.14: $n \times 7$ matrix with x, y, z, and normal u, v, w point cloud data. The last column indicates the irradiance values.



Parallelization

Parallelization: Multiprocessing

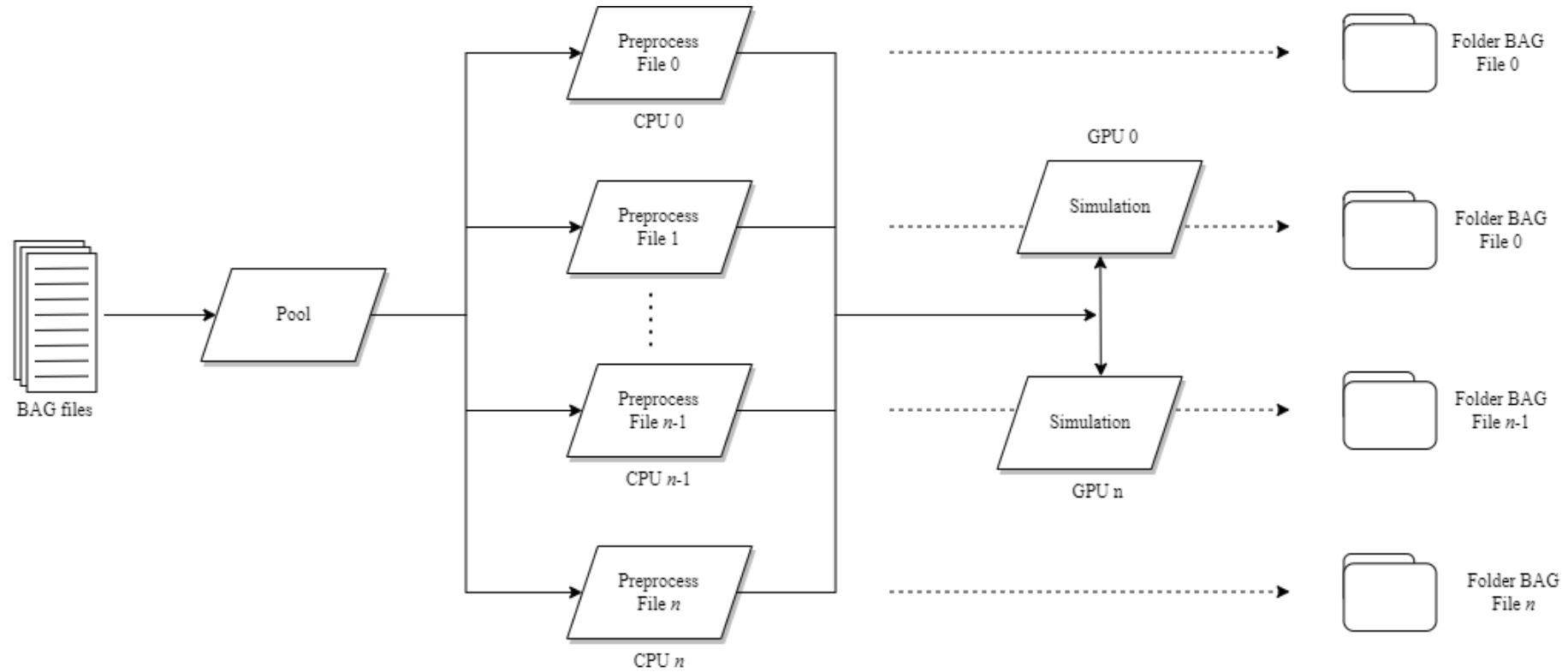
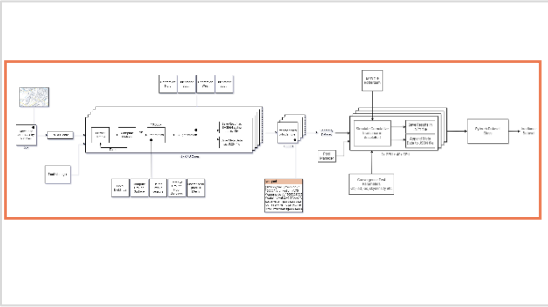

Parallelization: Datasets

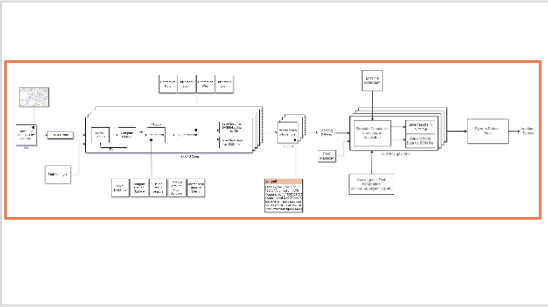

Name	Patch Size	Point Sampling Strategy	Number of Samples
dset100_xl_regular	100m x 100m	Regular	18.380
dset100_xl_random	100m x 100m	Poisson Disk	21.601
dset300_s_regular	300m x 300m	Regular	2.206
dset300_s_random	300m x 300m	Poisson Disk	2.602

Table 3.1: Four datasets developed with different properties.



Prediction

Simulation: Overview

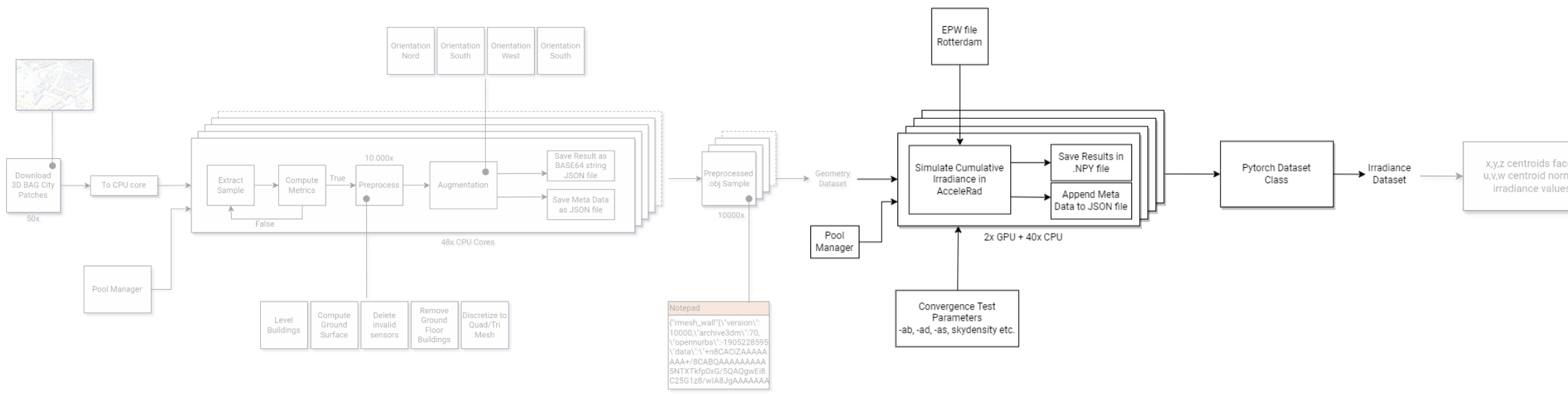

Prediction: Overview

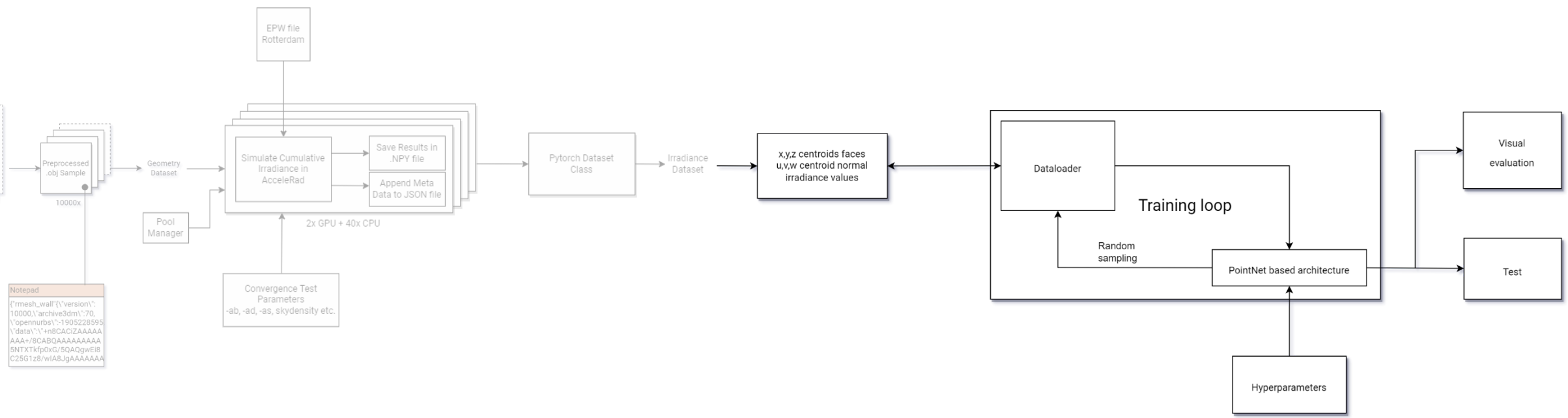

Prediction: PointNeXt

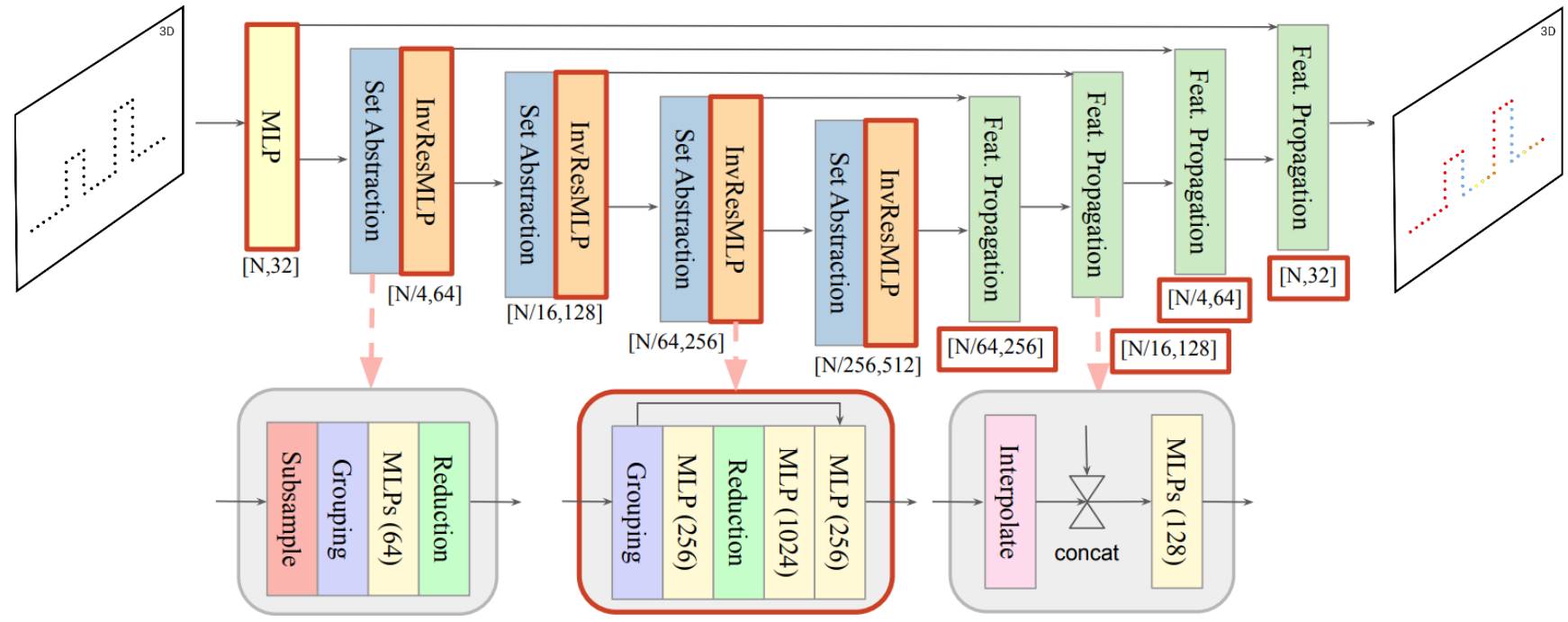
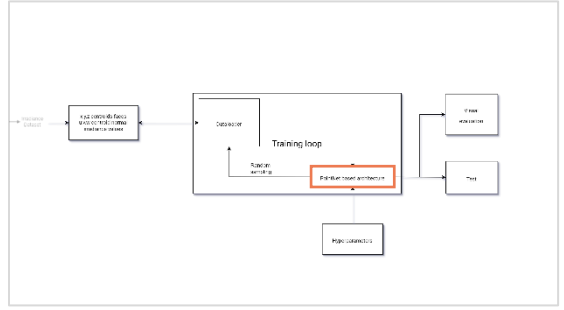

(Qian et al., 2022)



Prediction: PointNeXt – Hyperparameters

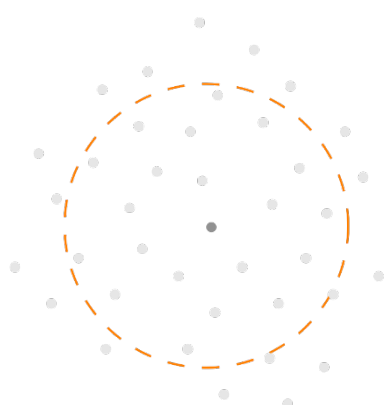
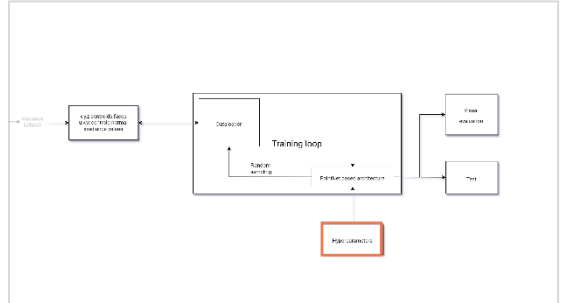

Radius

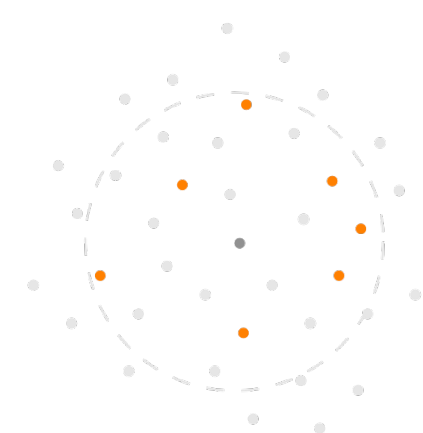

Nsample

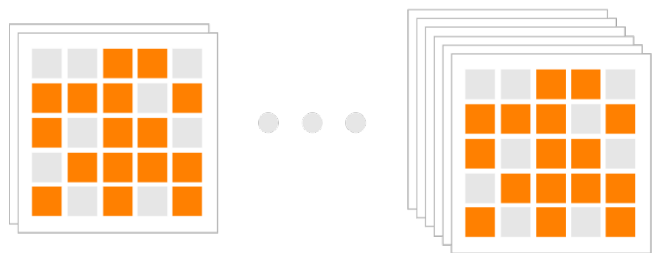

Width

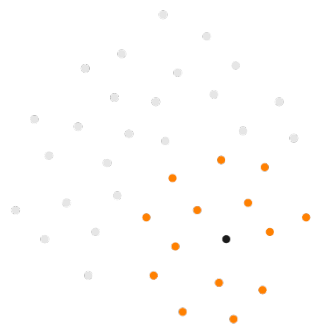

Voxel_max

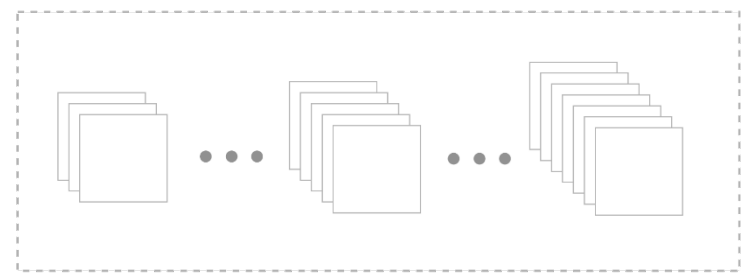

Expansion



Prediction: Hyperparameter Tuning

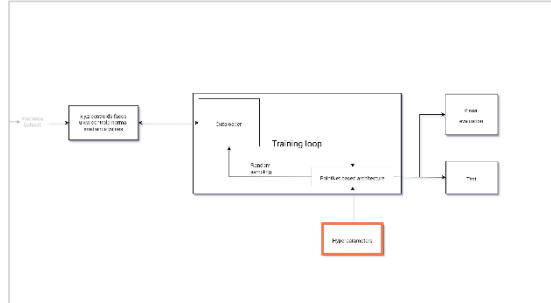

Hyperparameter Tuning												
Type	Model	Epochs	Hyper-parameters ^a	Dataset	Normalization norm,min, trr	Loss Function	Test RMSE ^b	Train RMSE ^{b,c}	Highest RMSE ^b	Lowest RMSE ^b	Macro avg. F1 score	Micro avg. F1 score
base	PointNet	25	None	100 regular	[-1,1], [-1,1]	MSE	86.87	93.49	134.19	22.94	0.41	0.67
base	PointNet++	25	None	100 regular	[-1,1], [-1,1]	MSE	62.99	45.42	106.18	17.32	0.58	0.76
base	PointNet-S	25	None	100 regular	[-1,1], [-1,1]	MSE	46.23	71.33	73.69	19.58	0.61	0.78
base	PointNet-B	25	None	100 regular	[-1,1], [-1,1]	MSE	58.92	80.90	107.68	23.64	0.47	0.73
base	PointNet-L	25	None	100 regular	[-1,1], [-1,1]	MSE	52.46	80.50	104.39	19.98	0.52	0.76
base	PointNet-XL	25	None	100 regular	[-1,1], [-1,1]	MSE	61.89	62.62	140.19	17.29	0.45	0.73
loss	PointNet-L	25	None	100 regular	[-1,1], [-1,1]	Delta	58.77	100.48	114.11	18.57	0.44	0.73
loss	PointNet-L	25	None	100 regular	[-1,1], [-1,1]	Reduction	54.28	82.10	110.34	22.05	0.49	0.75
loss	PointNet-L	25	None	100 regular	[-1,1], [-1,1]	WMSE	53.87	86.90	90.86	28.46	0.53	0.73
dset	PointNet-L	25	None	100 random ^d	[-1,1], [-1,1]	MSE	55.03	85.67	175.17	16.43	0.60	0.75
dset	PointNet-L	25	None	300 regular	[-1,1], [-1,1]	MSE	76.70	89.18	177.04	23.06	0.36	0.69
dset	PointNet-L	25	None	300 random ^d	[-1,1], [-1,1]	MSE	83.22	90.62	176.17	29.18	0.38	0.67
hyperparam	PointNet-L	25	expansion - 8	100 regular	[-1,1], [-1,1]	MSE	56.49	78.12	141.46	11.95	0.5	0.74
hyperparam	PointNet-L	25	vox_max - 24000	100 regular	[-1,1], [-1,1]	MSE	54.67	79.29	127.92	9.75	0.5	0.76
hyperparam	PointNet-L	25	act - leakyReLU	100 regular	[-1,1], [-1,1]	MSE	55.86	82.11	112.88	21.42	0.48	0.75
hyperparam	PointNet-L	25	nsample - 128	100 regular	[-1,1], [-1,1]	MSE	37.4	81.32	83.58	17.04	0.58	0.81
hyperparam	PointNet-L	25	nsample - 256	100 regular	[-1,1], [-1,1]	MSE	35.85	81.12	123.66	10.22	0.62	0.82
hyperparam	PointNet-L	25	nsample - 128	100 regular	[-1,1], [-1,1]	WMSE	32.14	87.53	94.46	11.56	0.74	0.85
hyperparam	PointNet-L	25	radius - 0.05	100 regular	[-1,1], [-1,1]	MSE	41.70	77.08	163.73	13.62	0.66	0.83
hyperparam	PointNet-L	25	radius - 0.025	100 regular	[0,1], [-1,1]	MSE	32.51	78.41	77.2	15.36	0.63	0.83
hyperparam	PointNet-L	25	radius - 0.025	100 regular	[-1,1], [-1,1]	MSE	33.77	78.33	120.85	15.64	0.64	0.83
hyperparam	PointNet-L	25	residual - True	100 regular	[-1,1], [-1,1]	MSE	46.34	75.07	72.25	19.09	0.58	0.78
hyperparam	PointNet-L	25	stride - [1,2,2,2]	100 regular	[-1,1], [-1,1]	MSE	50.23	83.36	90.96	22.02	0.51	0.77
hyperparam	PointNet-L	25	stride - [1,3,3,3]	100 regular	[-1,1], [-1,1]	MSE	71.39	81.93	133.05	21.19	0.39	0.7
hyperparam	PointNet-XL	25	nsample - 128	100 regular	[-1,1], [-1,1]	MSE	30.07	59.57	145.11	77.33	0.73	0.86
normalization	PointNet-L	25	None	100 regular	[0,1], [-1,1]	MSE	104.46	92.32	156.28	35.52	0.36	0.66
normalization	PointNet-L	25	None	100 regular	[0,1], [0,1]	MSE	93.05	101.57	138.34	33.72	0.39	0.68
normalization	PointNet-L	25	None	100 regular	[-1,1], [0,1]	MSE	57.7	80.93	106.39	19.27	0.46	0.75

^a None hyperparameters are expansion 4 vox_max 10000 act ReLU nsample 32 radius 0.1 residual False stride [1,4,4,4] ^b Unit: kWh/m². ^c Averaged through time weighted EMA (smoothing factor 0.99). ^d Poisson Disc point sampling

Table 4.3.: Hyperparameter tuning part A

Hyperparameter Tuning												
Type	Model	Epochs	Hyper-parameters ^a	Dataset	Normalization norm,min, trr	Loss Function	Test RMSE ^b	Train RMSE ^{b,c}	Highest RMSE ^b	Lowest RMSE ^b	Macro avg. F1 score	Micro avg. F1 score
epochs	PointNet-S	100	None	100 regular	[-1,1], [-1,1]	MSE	42.65	72.12	90.22	19.57	0.63	0.8
epochs	PointNet-L	100	None	100 regular	[-1,1], [-1,1]	MSE	56.9	77.91	107.51	21.22	0.47	0.74
super	PointNet-S	25	nsample - 128 radius 0.025 stride [1,2,2,2] residual True nsample - 128 radius 0.025	100 regular	[0,1], [-1,1]	MSE	39.44	73.95	155.61	18.8	0.61	0.79
super	PointNet-L	25	nsample - 128 radius 0.025 residual True	100 regular	[-1,1], [-1,1]	MSE	32.42	72.54	82.12	15.8	0.69	0.84
super	PointNet-XL	25	nsample - 128 radius 0.025 residual True	100 regular	[-1,1], [-1,1]	MSE	24.04	56.52	76.82	10.36	0.79	0.88
super	PointNet-L	25	nsample - 128 radius 0.025 residual True	100 random ^d	[-1,1], [-1,1]	MSE	37.27	64.52	78.21	11.51	0.71	0.84
super	PointNet-XL	25	nsample - 256 radius 0.05 ^e residual True	100 regular	[-1,1], [-1,1]	MSE	24.85	58.18	136.48	8.8	0.79	0.88
super	PointNet-L	25	nsample - 128 radius 0.025 residual True	100 regular	[-1,1], [-1,1]	aWMSE	37.42	59.57	137.06	22.44	0.75	0.83
hyper	PointNet-XL	100	nsample - 128 radius 0.025 residual True	100 regular	[-1,1], [-1,1]	MSE	29.42	56.43	158.38	9.81	0.77	0.87
hyper	PointNet-XL	100	nsample - 128 radius 0.025 residual True	100 random ^d	[-1,1], [-1,1]	MSE	21.10	58.65	152.19	9.63	0.83	0.90
hyper	PointNet-XL	100	nsample - 128 radius 0.025 residual True	300 regular	[-1,1], [-1,1]	MSE	36.71	62.52	127.19	14.22	0.62	0.81
hyper	PointNet-XL	100	nsample - 128 radius 0.025 residual True	300 random ^d	[-1,1], [-1,1]	MSE	48.53	66.68	127.60	22.28	0.58	0.76

^a None hyperparameters are expansion 4 vox_max 10000 act ReLU nsample 32 radius 0.1 residual False stride [1,4,4,4] ^b Unit: kWh/m². ^c Averaged through time weighted EMA (smoothing factor 0.99). ^d Poisson Disc point sampling. ^e Increased due to higher nsample

Table 4.4.: Hyperparameter tuning part B



Interaction

Interaction: Server-Client System

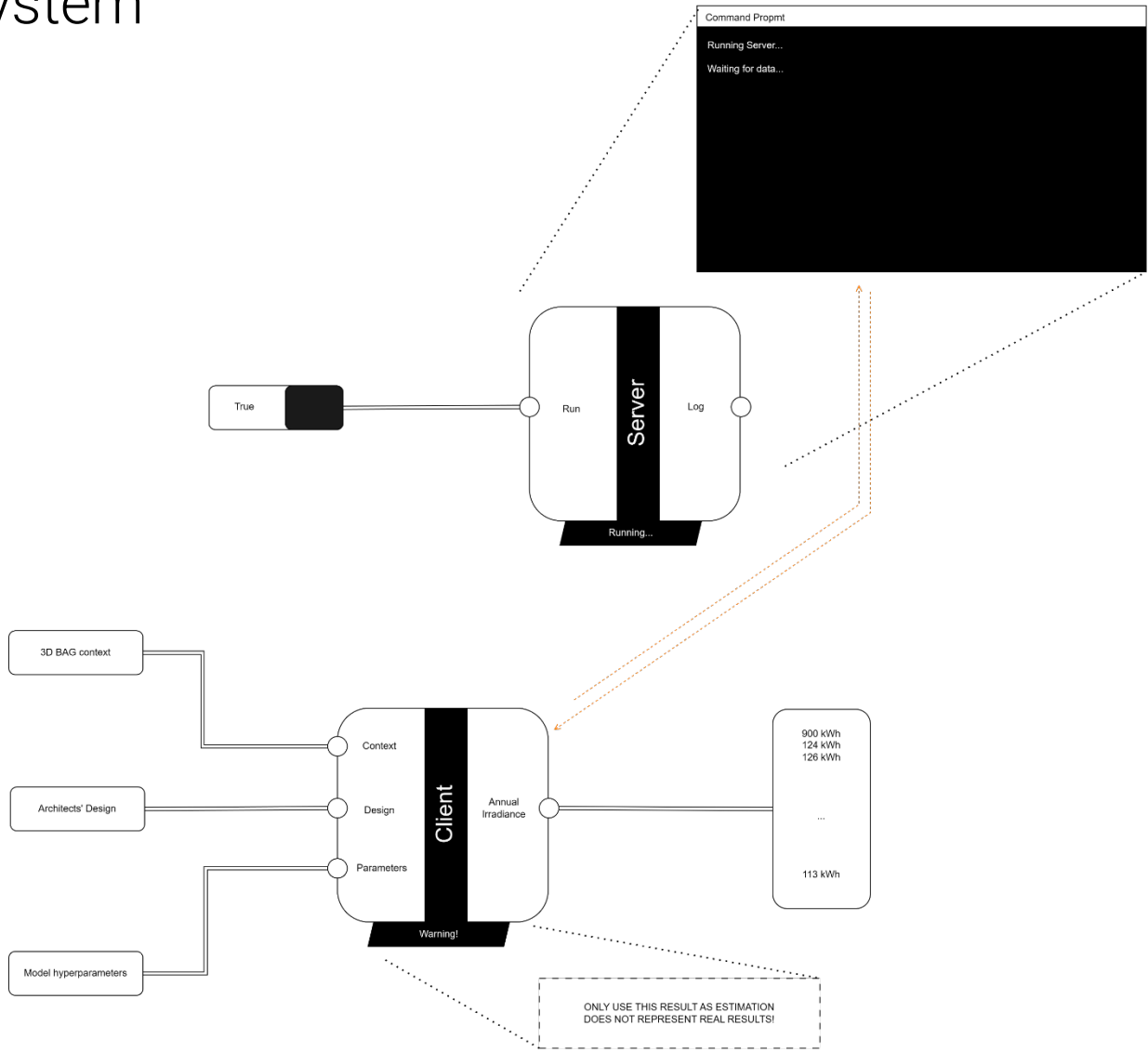

Analysis

Analysis: Baseline

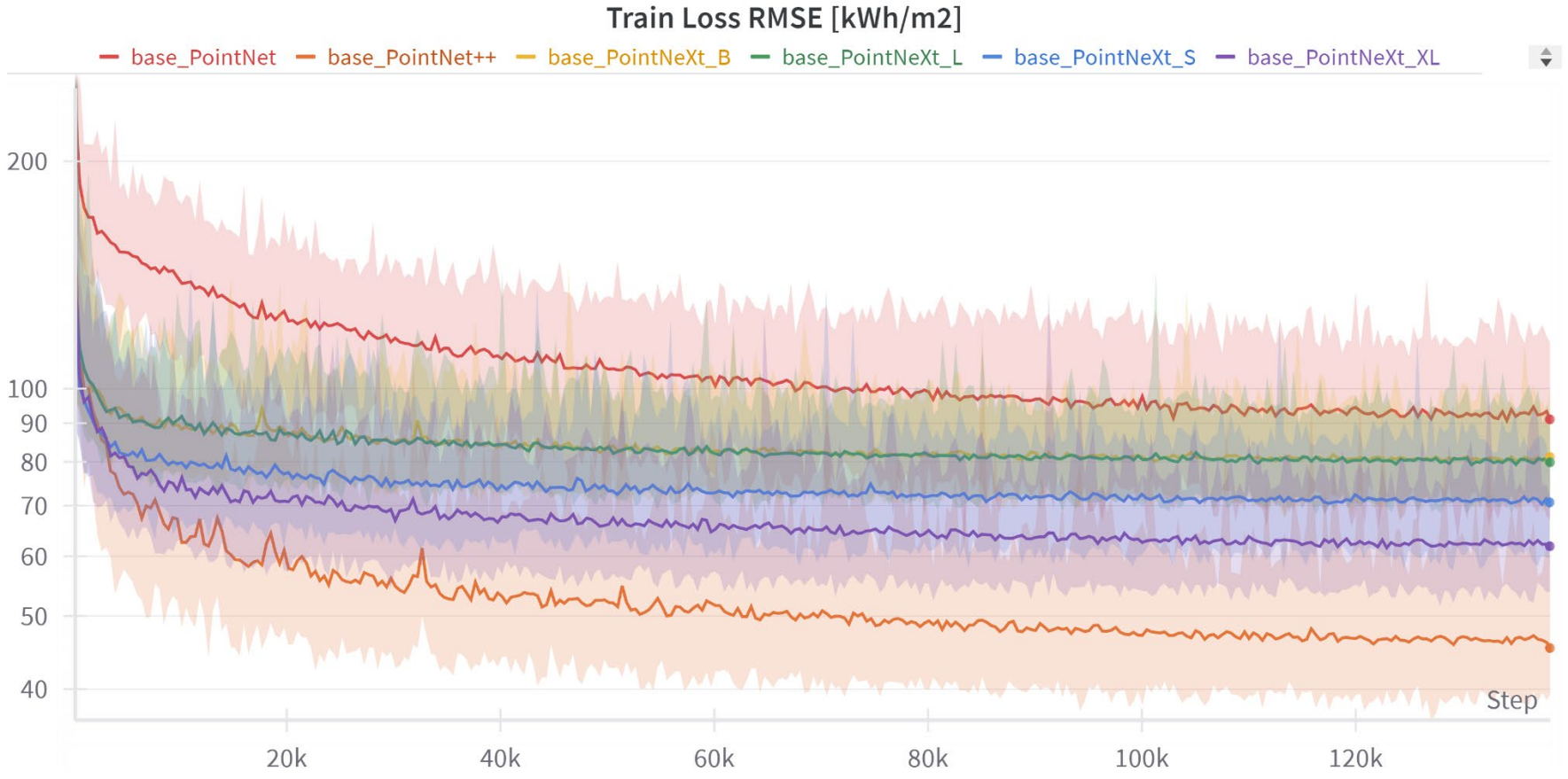

Analysis: Baseline

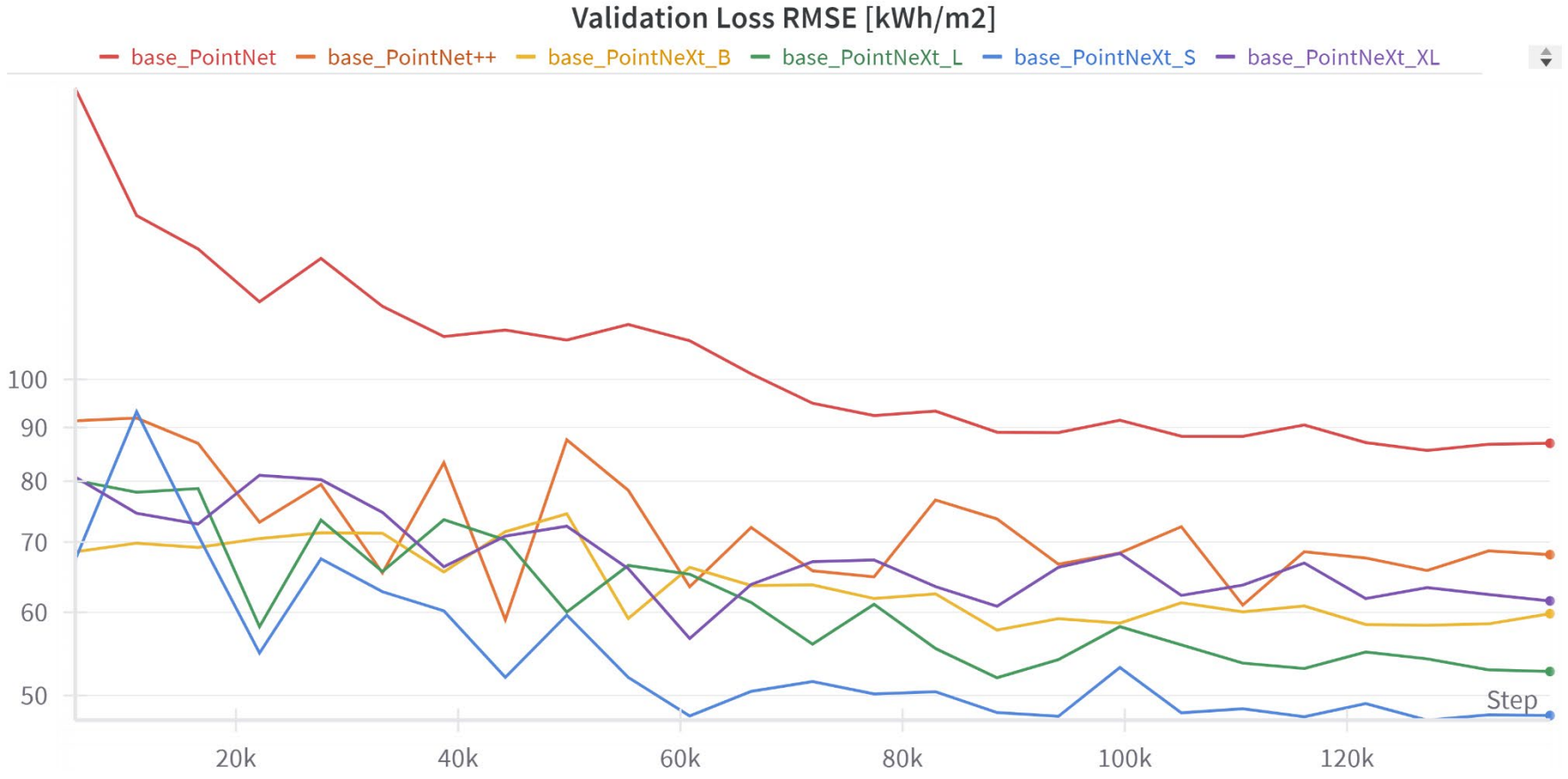

Analysis: Visualizations

Ground Truth
(synthesized)

Prediction

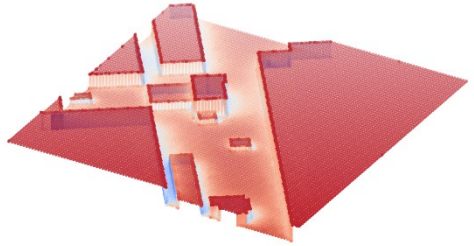
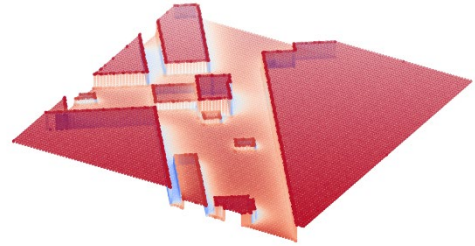

Ground Truth
(synthesized)

Prediction

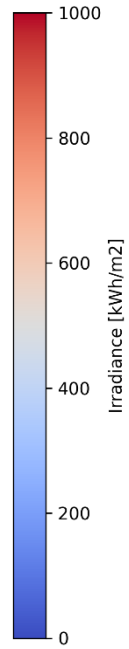
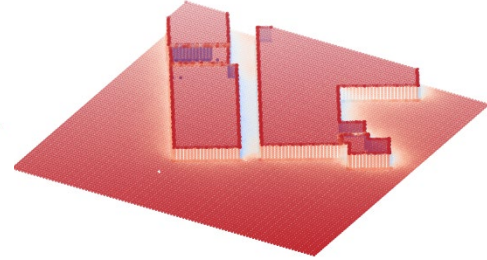
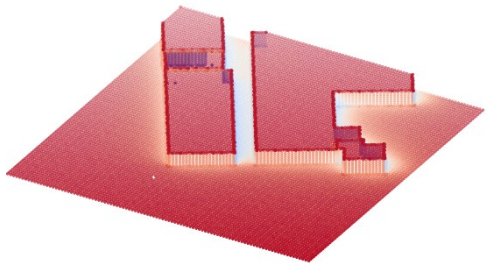

Ground Truth
(synthesized)

Prediction

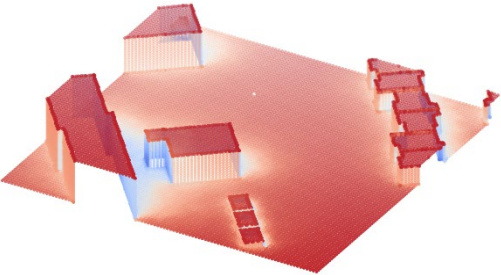
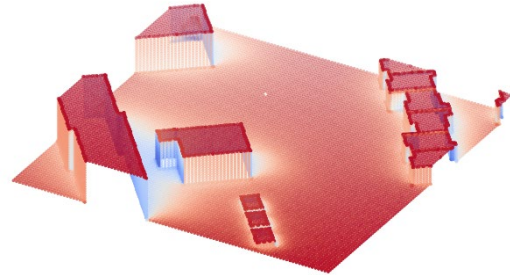

Ground Truth
(synthesized)

Prediction

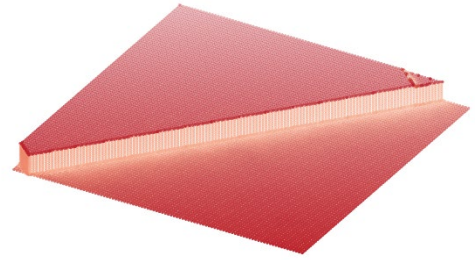
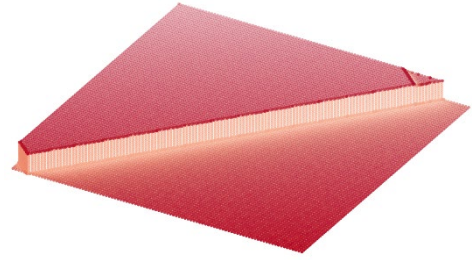

Analysis: Visualizations

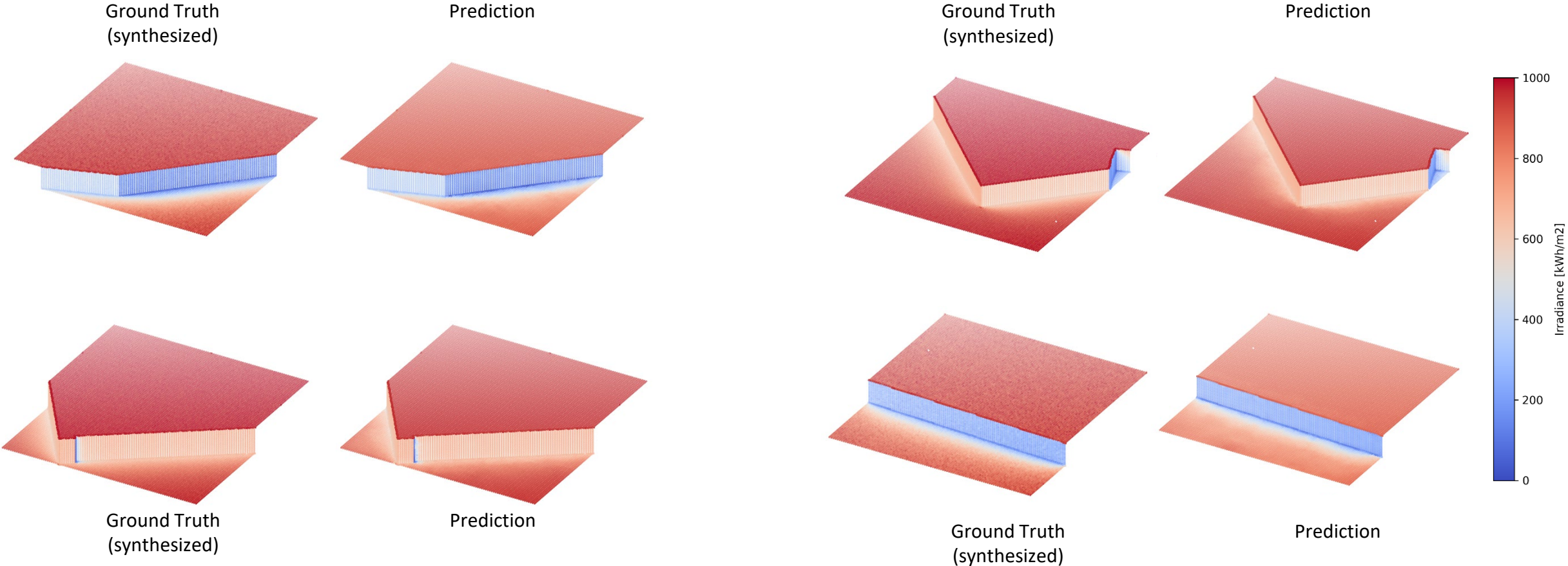

Analysis: Visualizations

Ground Truth
(synthesized)

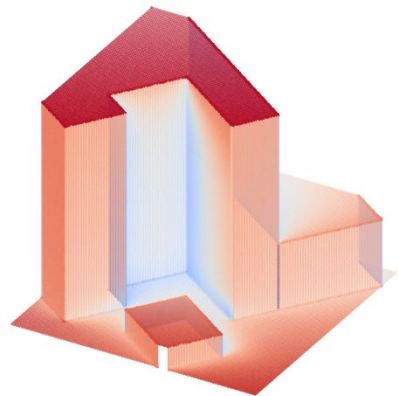

Prediction

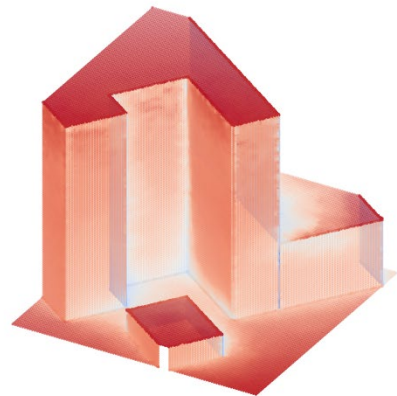

Ground Truth
(synthesized)

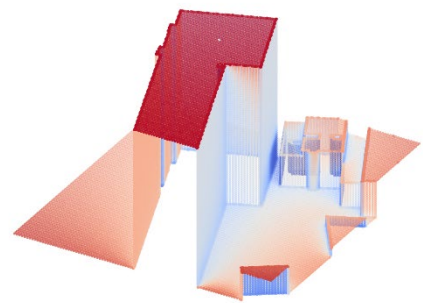

Prediction

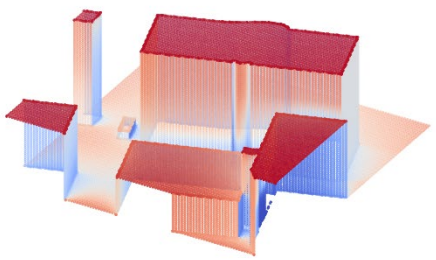
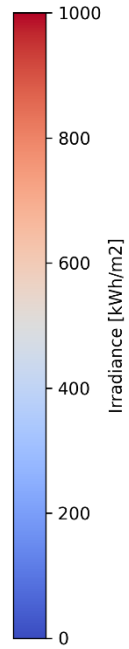
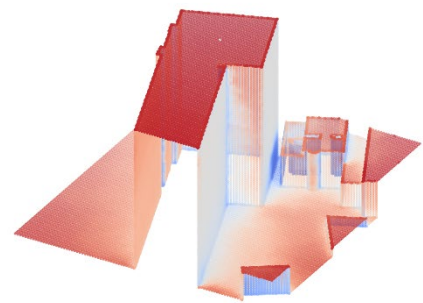

Ground Truth
(synthesized)

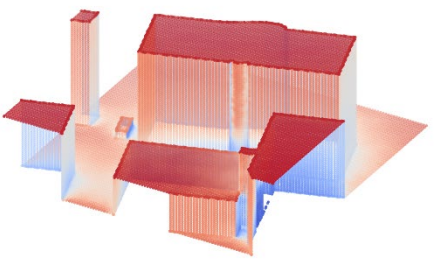

Prediction

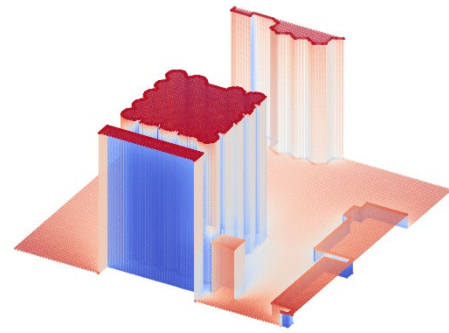

Ground Truth
(synthesized)

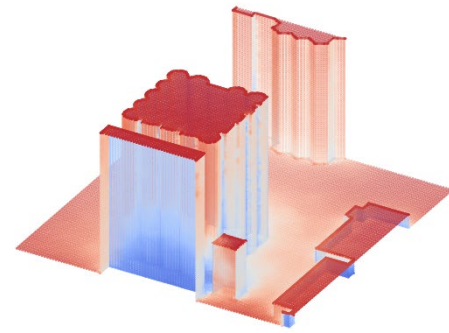

Prediction



Prediction: Accuracy Distribution

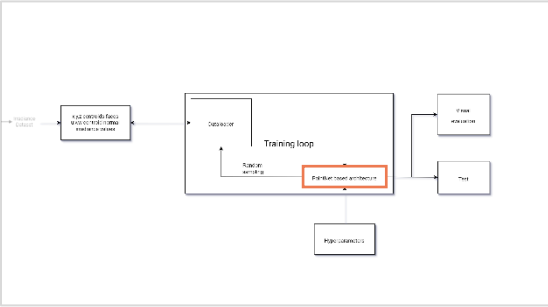

Predicted completely wrong
($> 200 \text{ kWh/m}^2$)

Predicted one domain off
(max error 200 kWh/m^2)

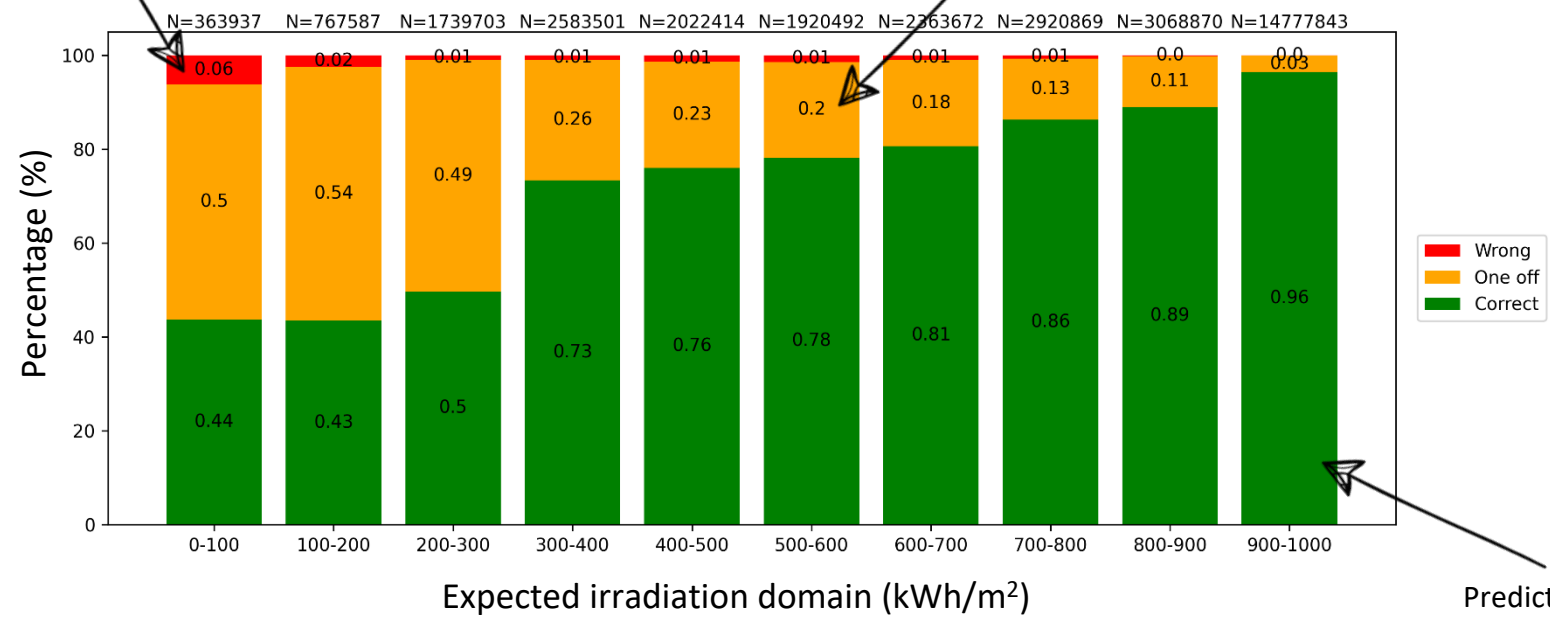

Predicted within domain
(max error 100 kWh/m^2)

Prediction: Accuracy Distribution

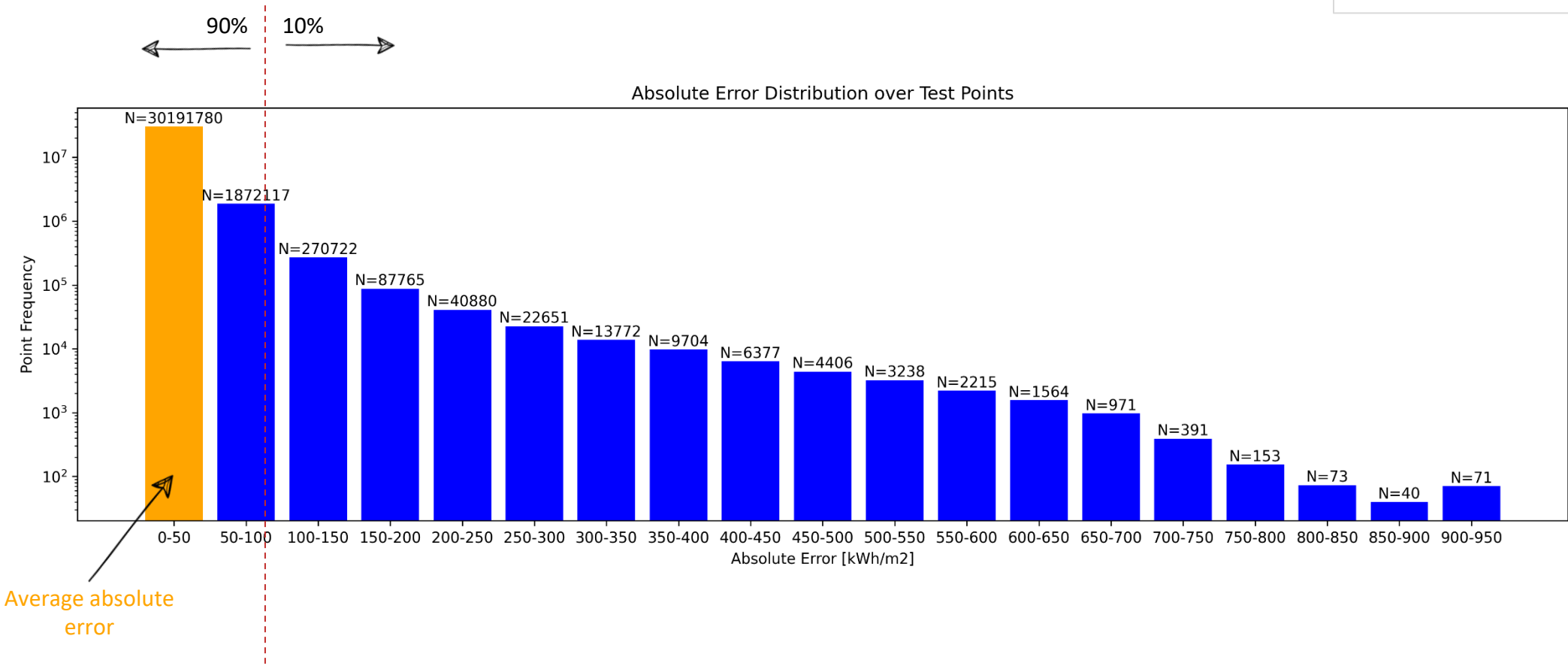
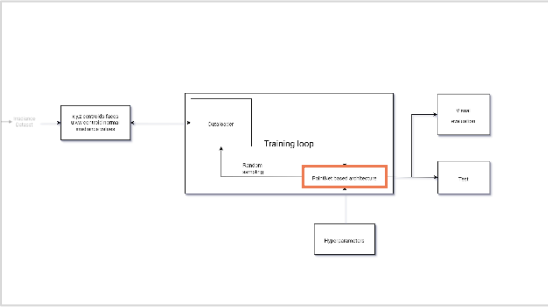

Analysis: Evaluation Speed

Configuration	Avg. Test Inference (s)
PointNeXt-L Base	0.184
PointNeXt-XL Base	0.291
PointNeXt-L Super	0.721
PointNeXt-XL Super	13.38



Interaction Demo



GPU Simulation

(~6x faster than CPU)

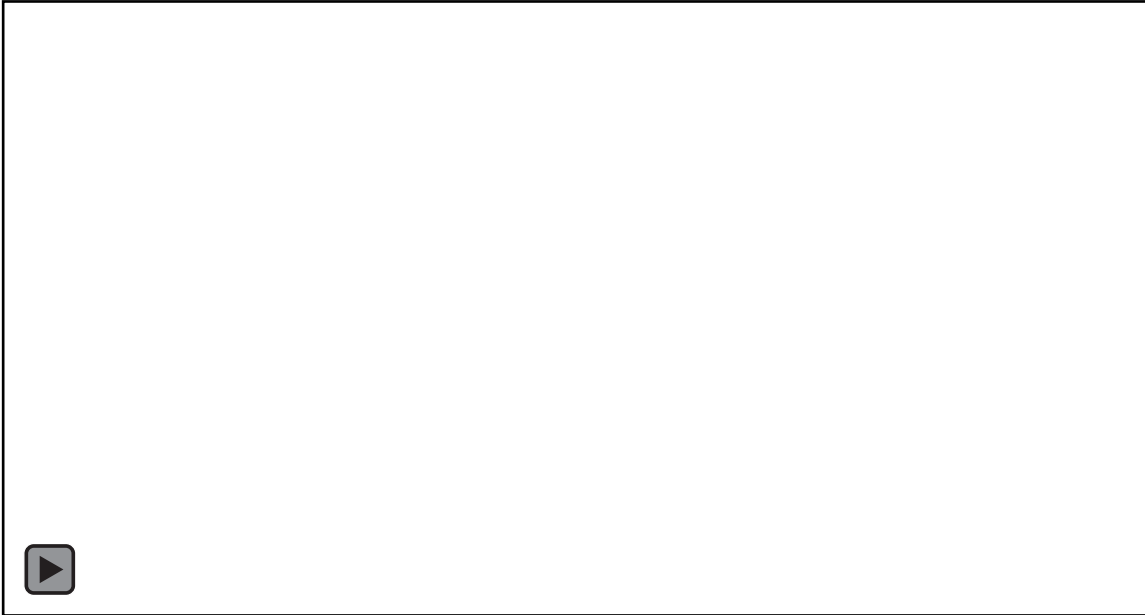

AI Prediction

(~10x faster than GPU Simulation)

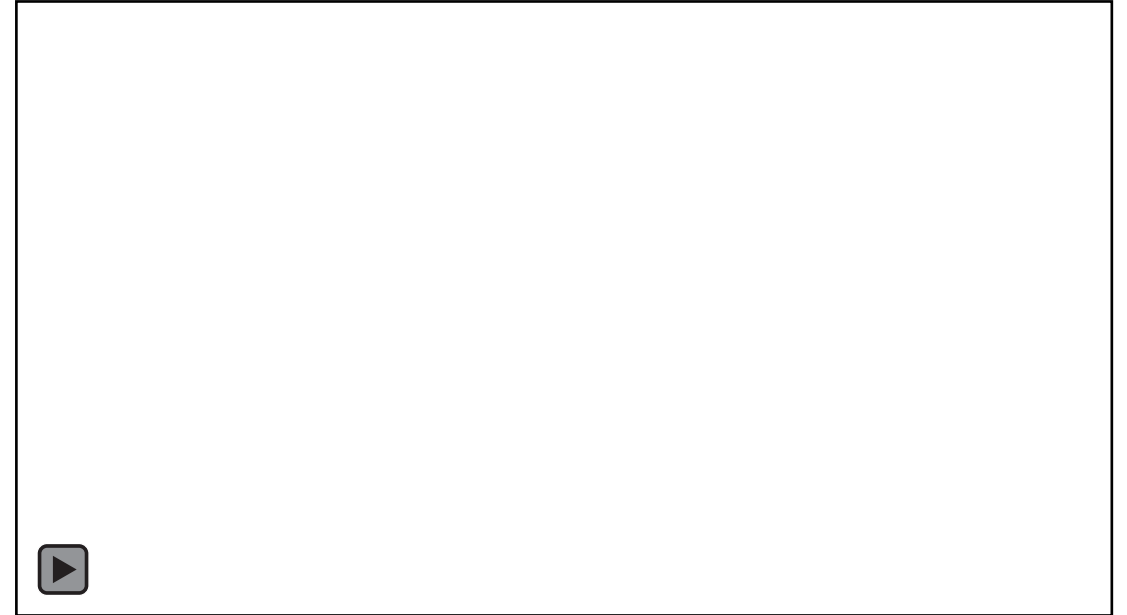

Power Generation Potential (Horizontal surfaces)

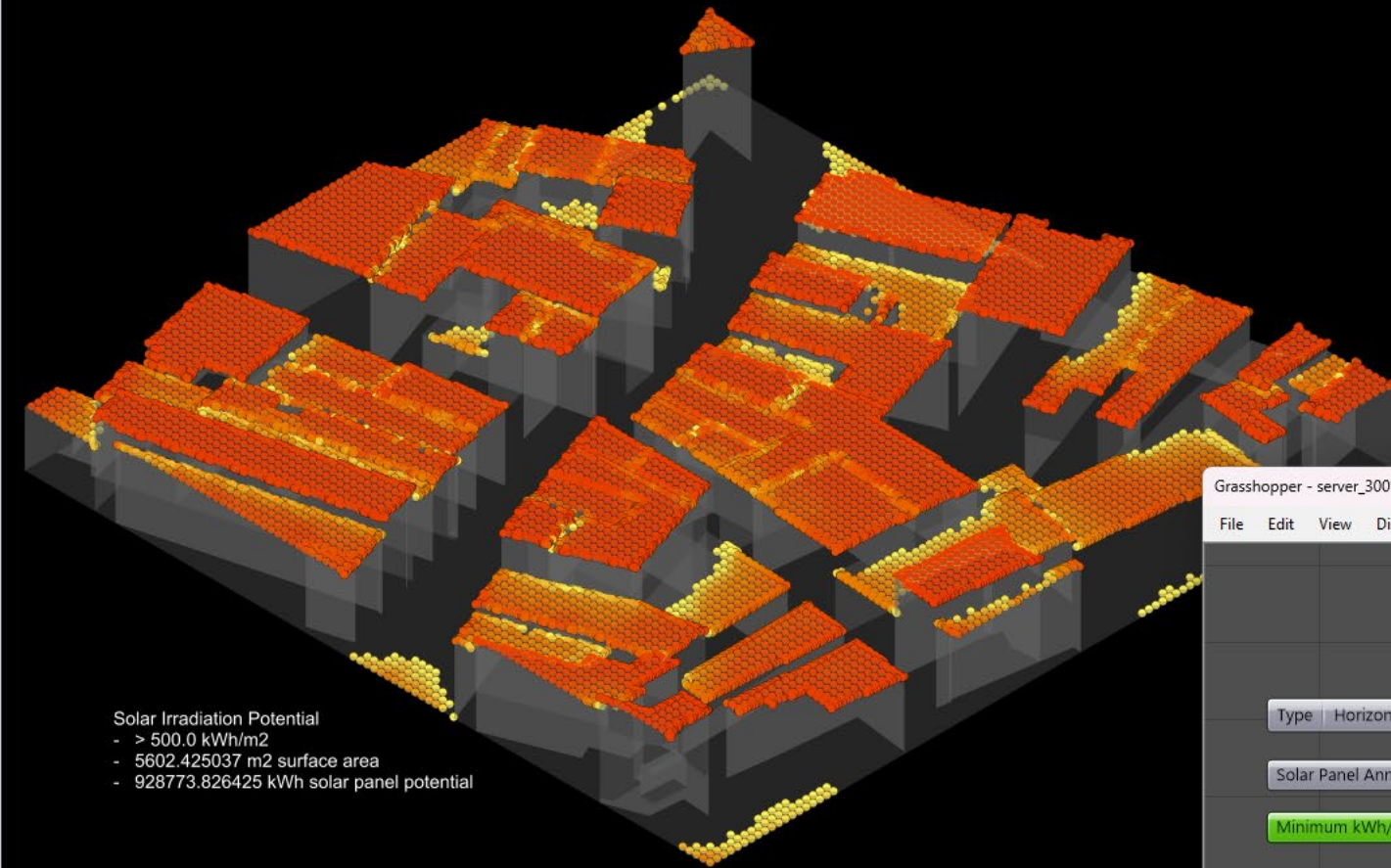

Solar Irradiation Potential
- > 500.0 kWh/m2
- 5602.425037 m2 surface area
- 928773.826425 kWh solar panel potential

Grasshopper - server_300*

File Edit View Display Solution Help MetaHopper server_300

Type: Horizontal

Solar Panel Annual Efficiency: 0.2

Minimum kWh/m2: 500

Area with higher irradiation than treshold (m2)
0 5602.425037

Power generation potential (kWh)
0 928773.826425

Autosave complete (140 seconds ago) 1.0.0007

Power Generation Potential (Vertical surfaces)

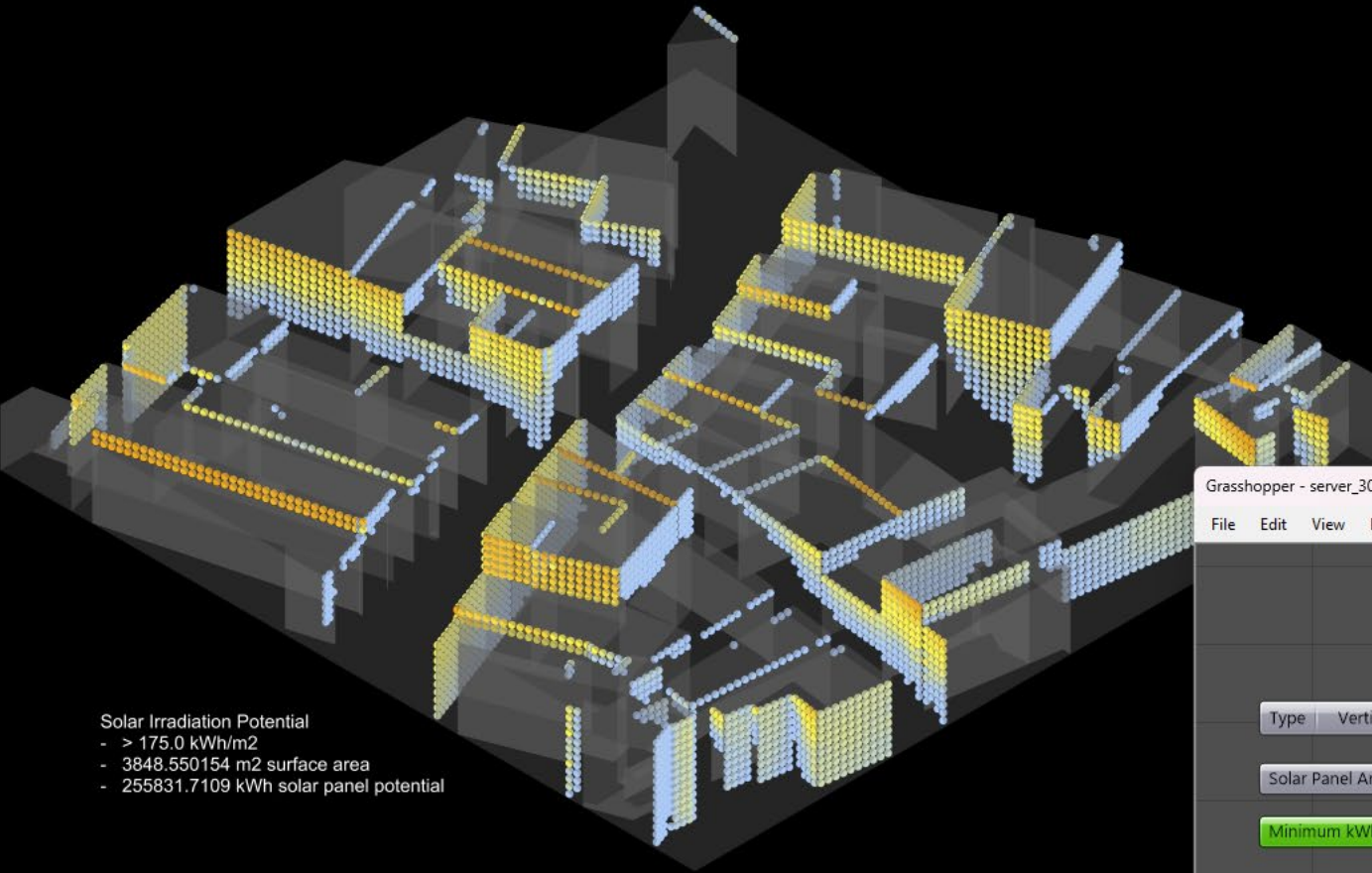

Solar Irradiation Potential
- > 175.0 kWh/m2
- 3848.550154 m2 surface area
- 255831.7109 kWh solar panel potential

Grasshopper - server_300*

File Edit View Display Solution Help MetaHopper server_300

Type Vertical

Solar Panel Annual Efficiency 0.2

Minimum kWh/m2 175

Area with higher irradiation than treshold (m2)
0 3848.550154

Power generation potential (kWh)
0 255831.7109

Autosave complete (80 seconds ago) 1.0.0007

```

C:\Users\Job de Vogel\conda x + v
Server finished End-to-end irradiation prediction in 9.844s...
VRAM used: 1211.92 MB

Connected by ('127.0.0.1', 53974)
-----
Processing data 3125188 bytes of data
Inferring data...
-----
Server finished End-to-end irradiation prediction in 9.709s...
VRAM used: 1211.92 MB

```

Galapagos Editor

Options Solvers Record

Start Solver Stop Solver

0.583356	<div style="width: 100%;"></div>
0.582686	<div style="width: 100%;"></div>
0.582382	<div style="width: 100%;"></div>
0.582274	<div style="width: 100%;"></div>
0.58184	<div style="width: 100%;"></div>
0.581811	<div style="width: 100%;"></div>
0.581704	<div style="width: 100%;"></div>

OK Cancel

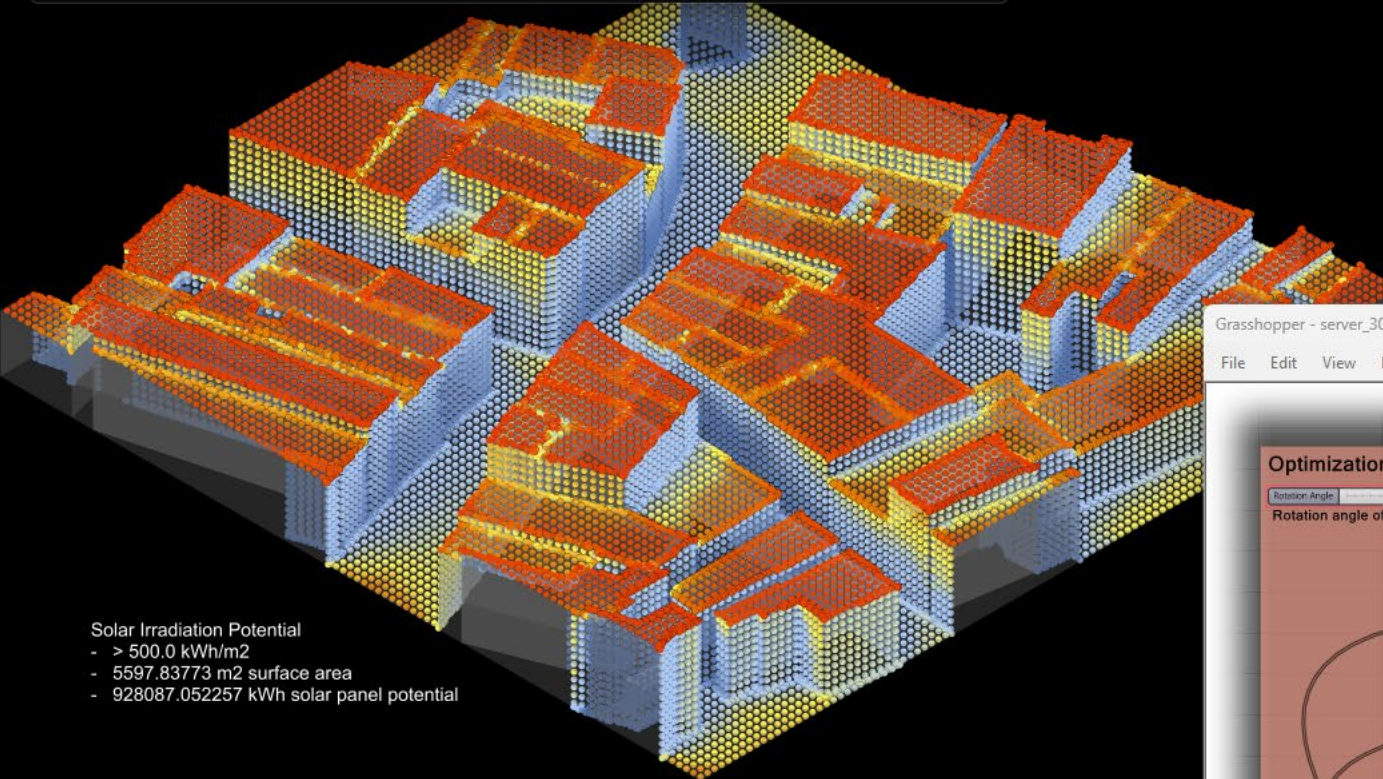

Solar Irradiation Potential

- > 500.0 kWh/m2
- 5597.83773 m2 surface area
- 928087.052257 kWh solar panel potential

Grasshopper - server_300*

File Edit View Display Solution Help MetaHopper

server_300

Optimization Procedure

Rotation Angle: 287

Rotation angle of tower design

```

graph LR
    V[Vertical irradiation] --> MA1[Mass Addition]
    H[Horizontal irradiation] --> MA2[Mass Addition]
    L1[List Length] --> MA1
    L2[List Length] --> MA2
    MA1 --> D1[Division]
    MA2 --> D2[Division]
    D1 --> S[Subtraction]
    D2 --> S
    S --> A[Addition]
    A --> F[Fitness]

```

Solution completed in ~16.7 seconds (0 seconds ago)

1.0.0007

Brute-Force Design Optimization

Discussion

Discussion: Generation/Simulation Improvements

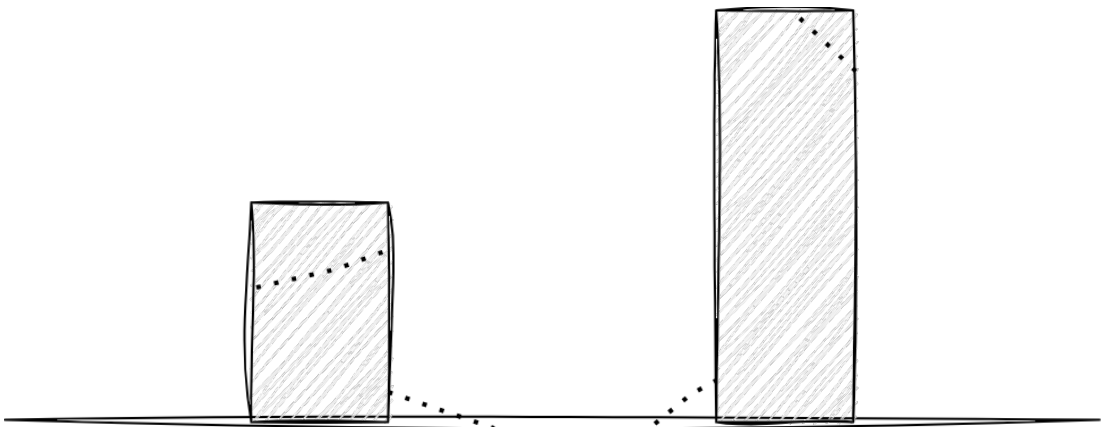

Finetune preprocessing procedure (for higher detail)

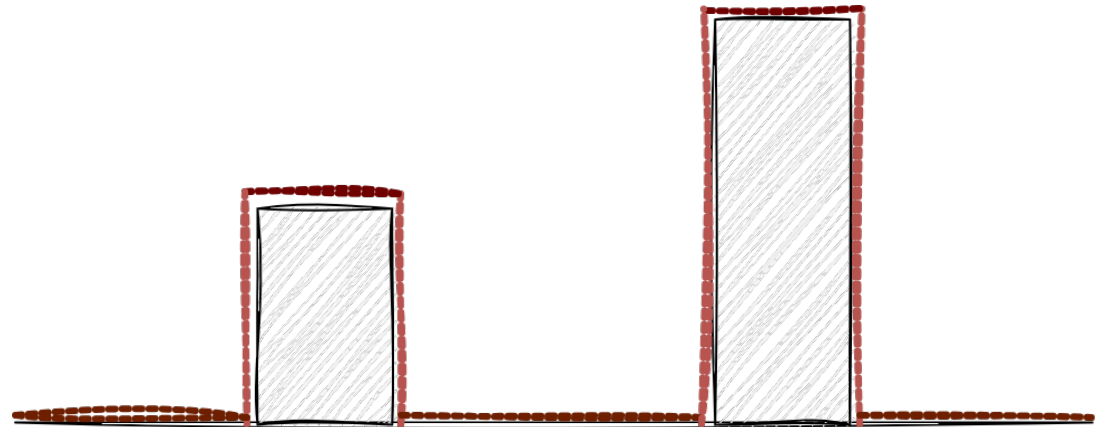

Add materials

Discussion: Parallelization Improvements

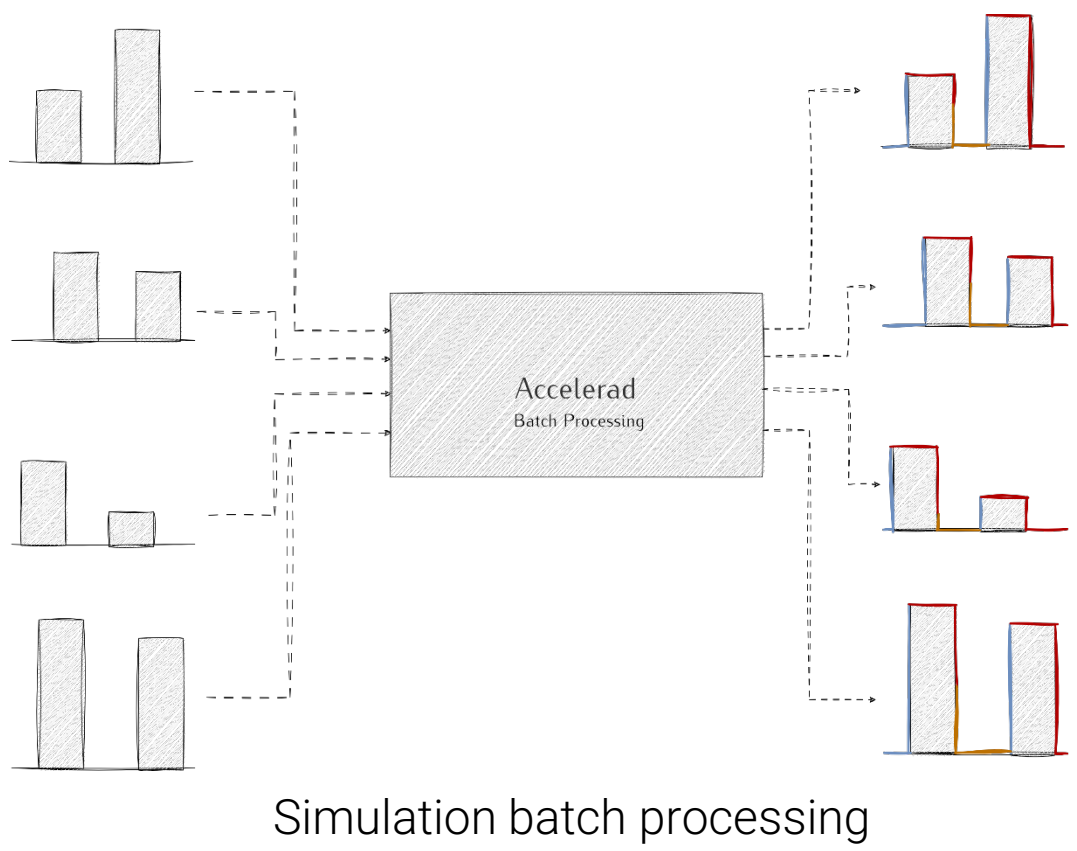

Discussion: Prediction Improvements

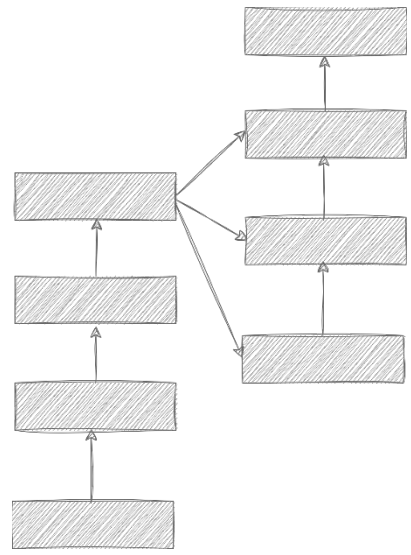

Transformer Model

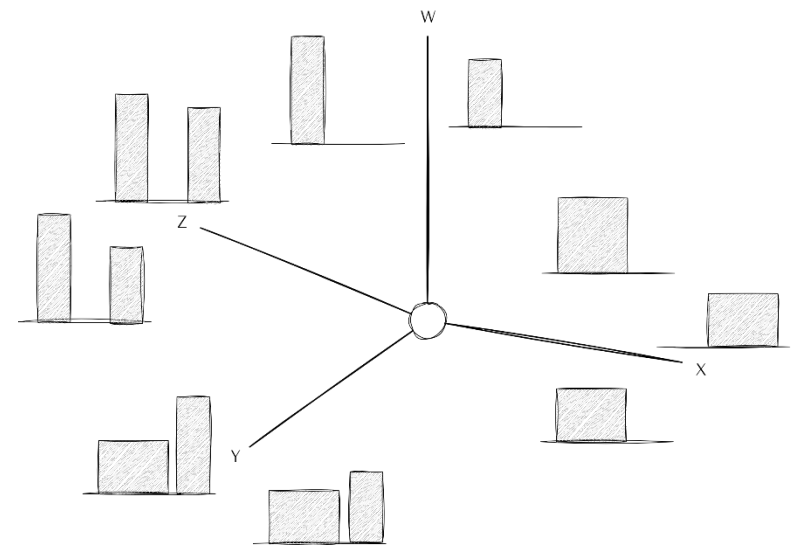

Urban Typology Clustering/
Dimensionality Reduction

Discussion: Prediction Improvements

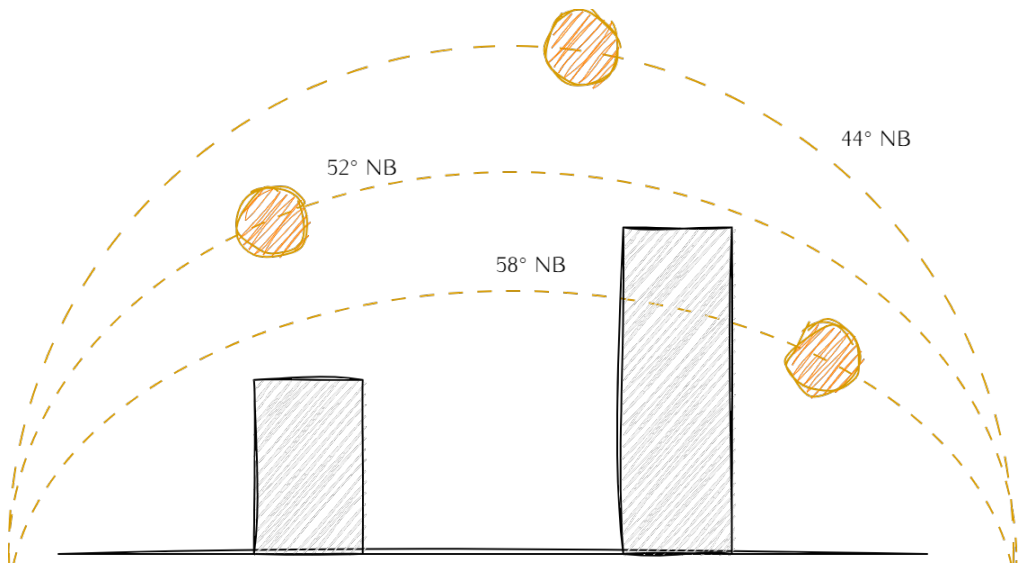

Location invariance through transfer learning or DC prediction

Discussion: Parallelization Improvements

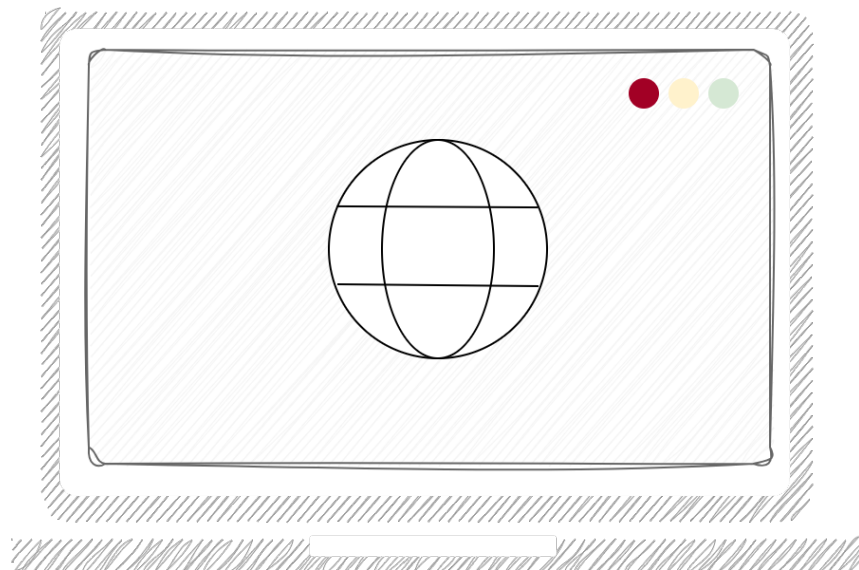

Web-based GUI



Conclusion

Conclusion

Model Accuracy

- Random point cloud: avg. 21 kWh/m²
- Regular point cloud: avg. 24 kWh/m²

Further Research

- Aim for better accuracy through more advanced networks and dataset improvements

Future

- This research paves the way for *holistic generative design models*

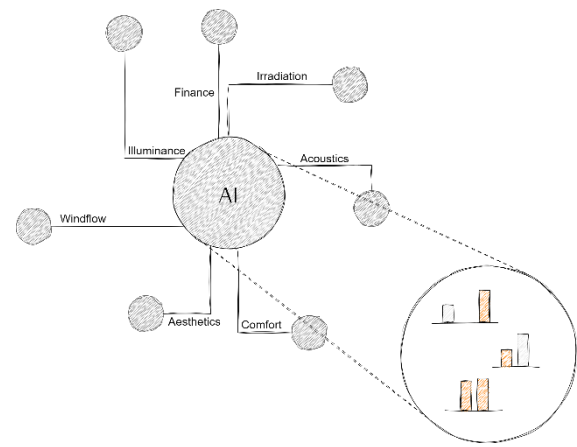
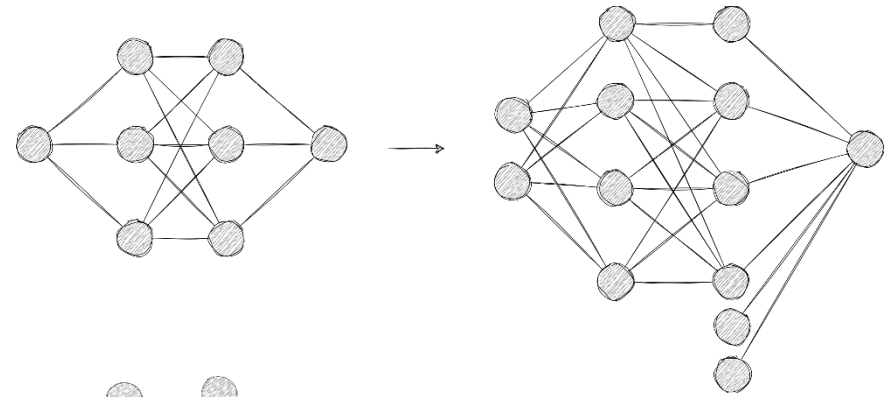



Towards Solar Irradiation Prediction on 3D Urban Geometry using Deep Neural Networks

Job de Vogel / 03 September 2024

Main mentor: dr. ir. Michela Turrin
Second mentor: dr. ir. Seyran Khademi

Graduation committee member: Prof.dr.ir. M.G. Elsinga

‘Het grootste gevaar is niet dat robots op ons gaan lijken, maar dat wij op robots gaan lijken.’

‘The greatest danger is not that robots will be like us, but that we will be like robots.’

Frank Mulder, De Groene Amsterdammer