

welcome

p-five | yara valente | april 16th 2019

tutors: roel van de pas, willemijn wilms floet, hubert van der meel
external: daan vitner

subversive
submarine

subversive
submarine

ondermijnende
onderzeer

ondermijnende onderzeeër

H
E
M
A

Peek & Cloppenburg

Peek & Cloppenburg



H
E
M
A

TOILET







toilet ←



toilet













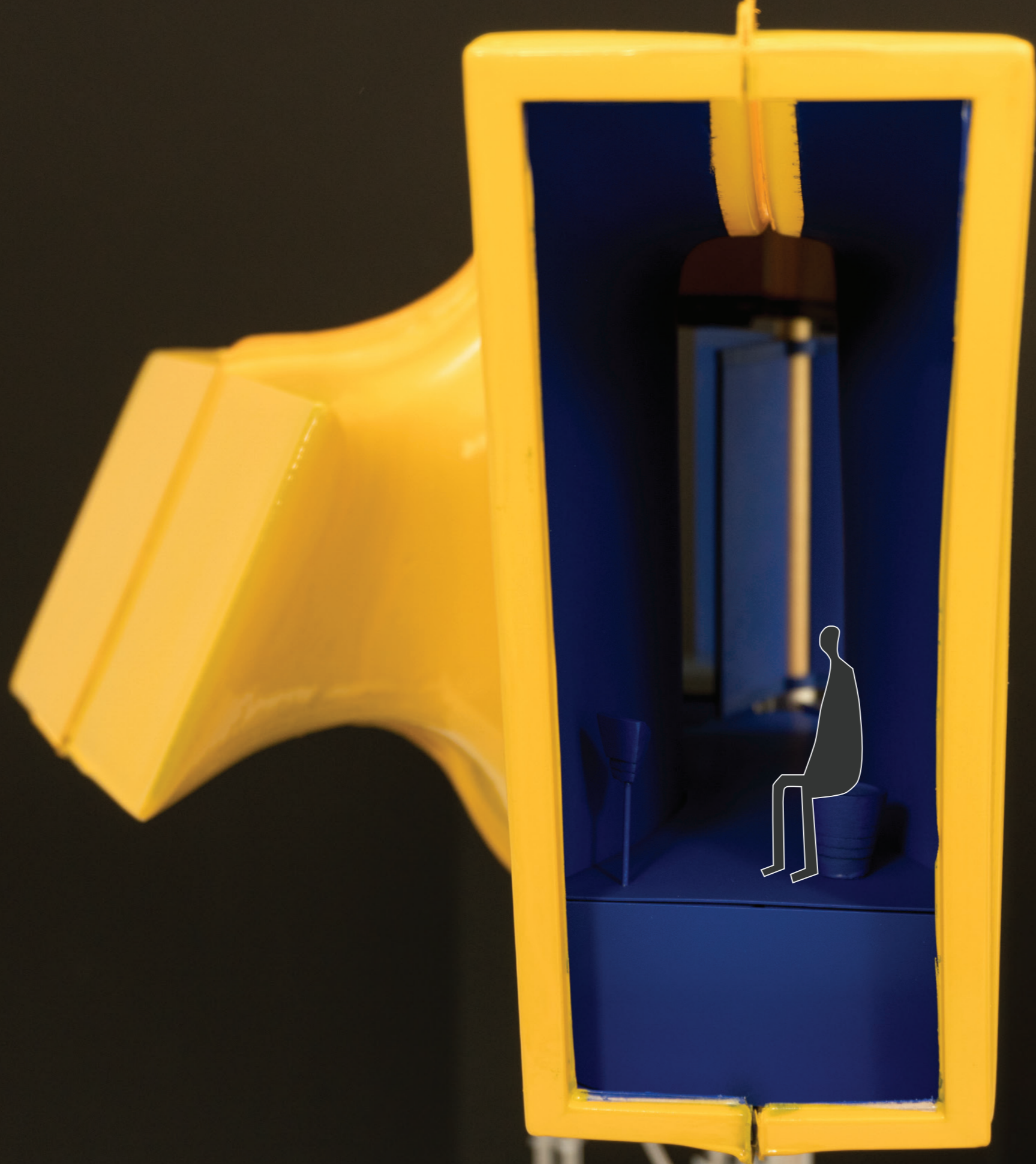

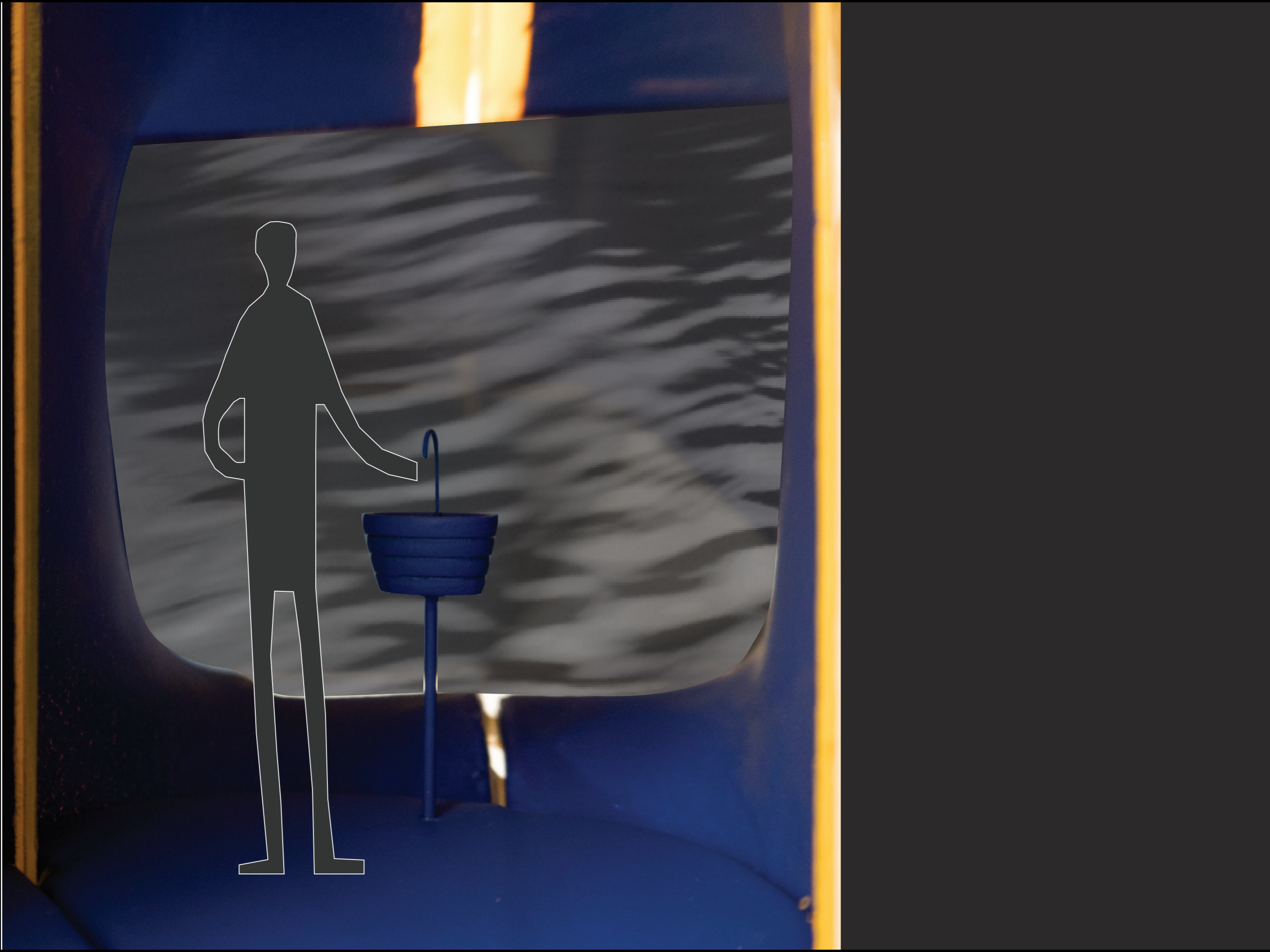

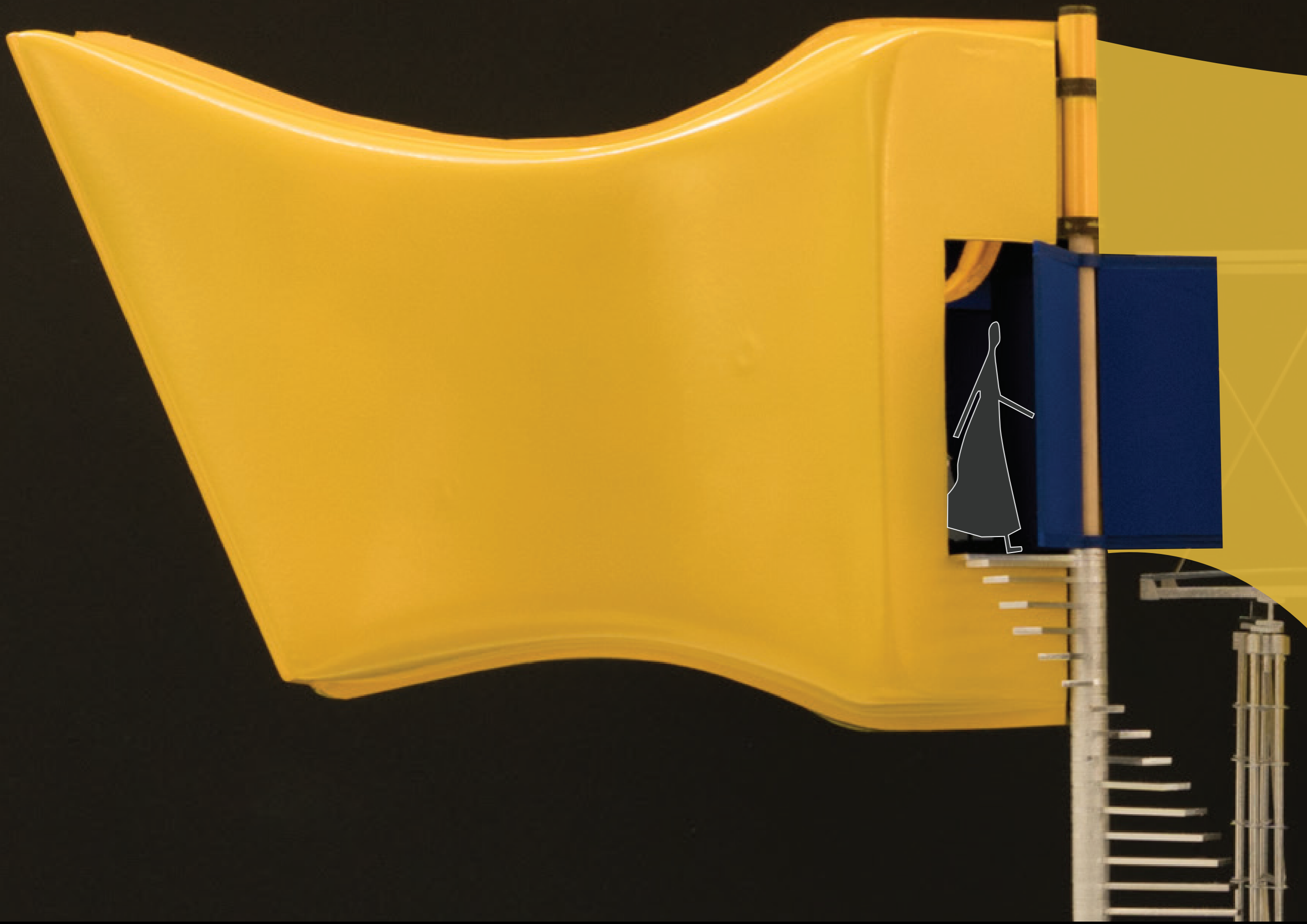





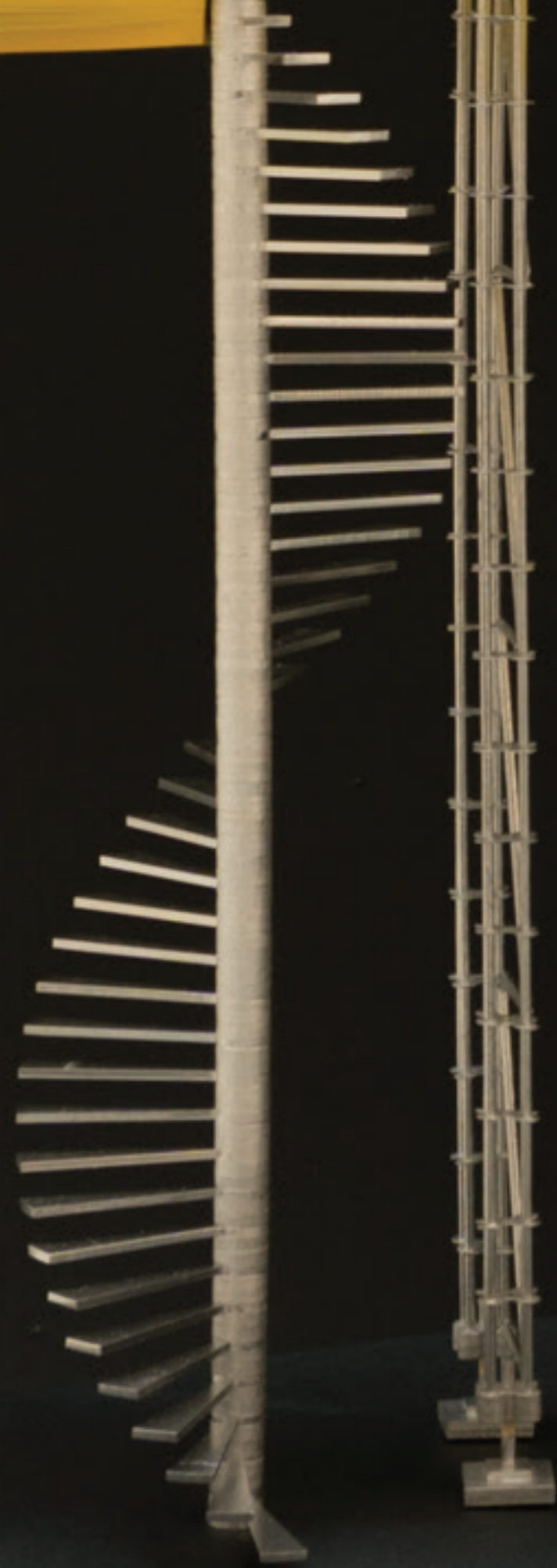

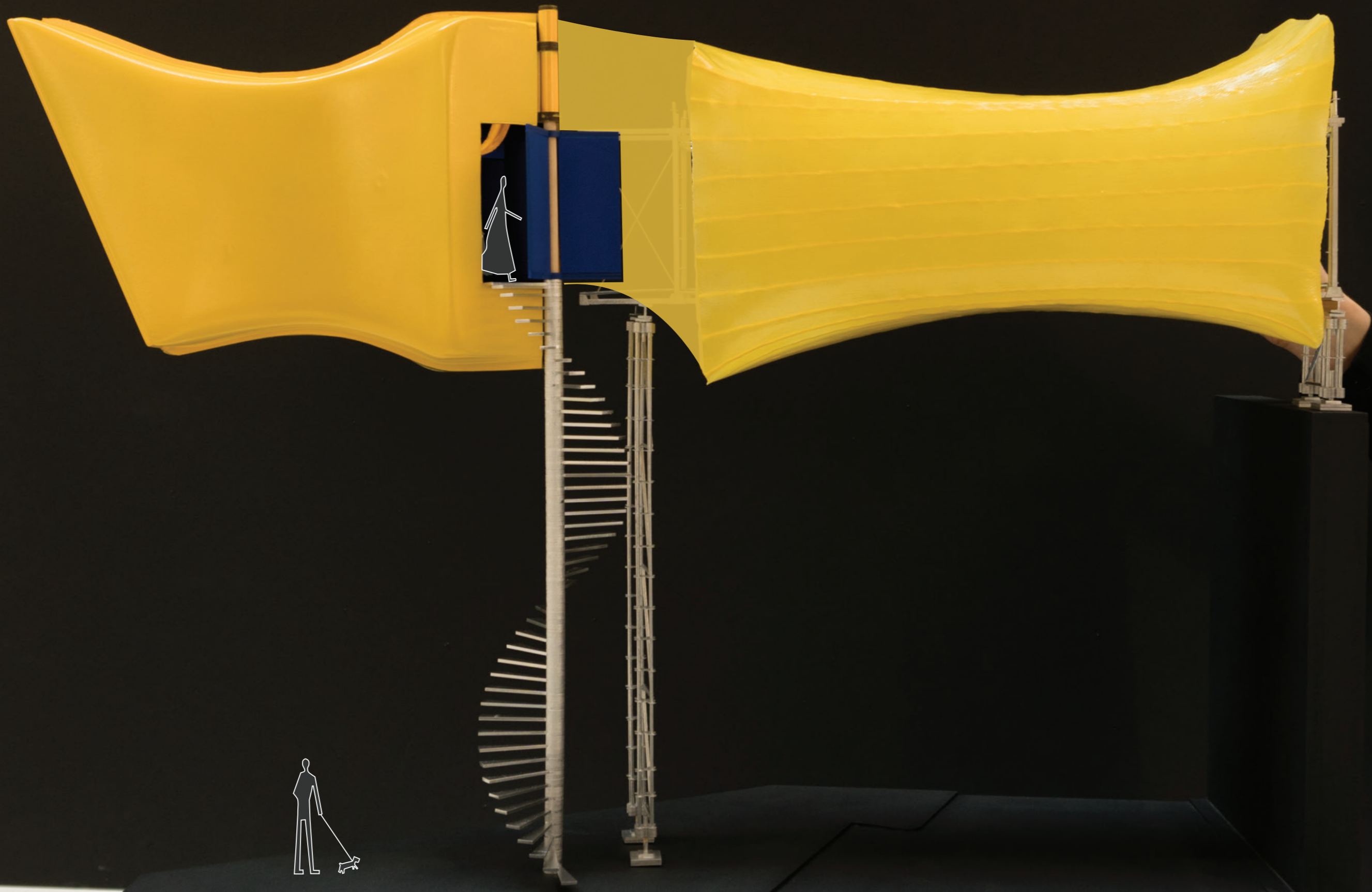



fascinatie







agenda

onderzoek

toepassing

uitwerking

slot



Draaiend Huis, John Körmeling, 2008

onderzoek

vraag

**Op welke manieren kan architectuur onze verwachtingen
ondermijnen?**

CASES MANIFESTO METHODS ABOUT

Filter

Search 🔍

Order by: Date added ▾



Subversive Submarine
Yara Valente

Provoke Wonder Imagination
Humour Confusion Curiosity
Disruption Play
View Passing of Time
Body Movement Nature Water
Contrast in Shape Mirrors
Contrast in Material Contrast in Color
Light
Landmark Parasite Installation Art
Intervention Art



Stairway to Heaven
Tatzu Nishi

Wonder Imagination
View Body Movement Nature
Installation Art



Wrapped Trees
Cristo & Jeanne-Claude

Wonder Imagination
View Nature Wind
Land Art



Wrapped Reichstag
Cristo & Jeanne-Claude

Wonder Imagination Curiosity
Disruption
View Wind
Landmark Art Performance



Subversive Methods



Engel
Tatzu Nishi



Turning the Place Over
Richard Wilson



Kids Restaurant
Wutopia Lab

+
-

Filter



Vortex
1024 Architecture

- Imagination
- Contrast in Shape
- Contrast in Material
- Parasite
- Installation Art



Swimming Pool XX
Leandro Erlich

- Wonder
- Imagination
- Confusion
- Sound
- Installation Art



Piazza D'Italia
Charles Moore

- Provoke
- Imagination
- Confusion
- Curiosity
- View
- Monument

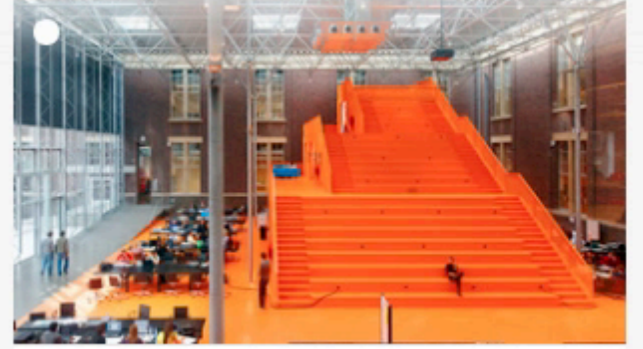

The Why Factory Tribune
MVRDV

- Curiosity
- Landmark



Nest
Benjamin Verdonck

- Provoke
- Confusion
- Curiosity
- Disruption
- Sound
- Performance



UFO over Delft
Theo Jansen

- Provoke
- Imagination
- Humour
- Confusion
- Curiosity
- Disruption
- Sound
- View
- Performance



Bunker 599
RAAAF

- Provoke
- Contrast in Shape
- Re-use
- Monument



BarRectum
Joep van Lieshout

- Provoke
- Imagination
- Art



+



+
-

- METHODS**
- ✓ Confusion
 - ✓ Curiosity
 - ✓ Disruption
 - ✓ Humour
 - ✓ Imagination
 - ✓ Play
 - ✓ Provoke
 - ✓ Wonder

- SENSES**
- ✓ Air
 - ✓ Body Movement
 - ✓ Contrast in Color
 - ✓ Contrast in Material
 - ✓ Contrast in Shape
 - ✓ Light
 - ✓ Mirrors
 - ✓ Nature
 - ✓ Passing of Time
 - ✓ Re-use
 - ✓ Scent
 - ✓ Sound
 - ✓ Temperature
 - ✓ View
 - ✓ Water
 - ✓ Wind

- TYPES**
- ✓ Architecture
 - ✓ Art
 - ✓ Conceptual Art
 - ✓ Film
 - ✓ Installation Art
 - ✓ Intervention Art
 - ✓ Kinetic Art
 - ✓ Land Art
 - ✓ Landmark
 - ✓ Monument
 - ✓ Parasite
 - ✓ Performance
 - ✓ Playground
 - ✓ Public Furniture
 - ✓ Relational Art

- SIZE**
- Object Installation Building Structure
-
- PLACEMENT**
- Inside Outside
-
- TIMEFRAME**
- Temporary Permanent
-
- KINETIC**
- Static Dynamic
-
- RELATION**
- Spectator Participant



Nest
Benjamin Verdonck

Provoke Confusion Curiosity
Disruption
Sound
Performance



UFO over Delft
Theo Jansen

Provoke Imagination Humour
Confusion Curiosity Disruption
Sound View
Performance



Bunker 599
RAAAF

Provoke
Contrast in Shape Re-use
Monument



BarRectum
Joep van Lieshout

Provoke Imagination
Art



CASES | MANIFESTO | METHODS | ABOUT

Filter Wonder X Body Movement X

Search

Order by: Date added



Subversive Submarine
Yara Valente

- Provoke
- Wonder
- Imagination
- Humour
- Confusion
- Curiosity
- Disruption
- Play
- View
- Passing of Time
- Body Movement
- Nature
- Water
- Contrast in Shape
- Mirrors
- Contrast in Material
- Contrast in Color
- Light
- Landmark
- Parasite
- Installation Art
- Intervention Art



Stairway to Heaven
Tatzu Nishi

- Wonder
- Imagination
- View
- Body Movement
- Nature
- Installation Art



Engel
Tatzu Nishi

- Wonder
- Imagination
- Humour
- Curiosity
- Body Movement
- Installation Art



The Third Room
Unknown

- Wonder
- Imagination
- Body Movement
- Contrast in Shape
- Contrast in Material
- Light
- Art
- Installation Art

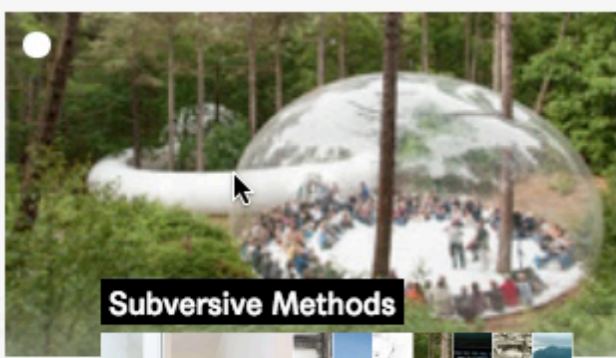

Subversive Methods



Water Mirror
Michel Corajoud



Upside Down Mushroom Room
Carsten Höller



Sun Tunnels
Nancy Holt



Verwarring

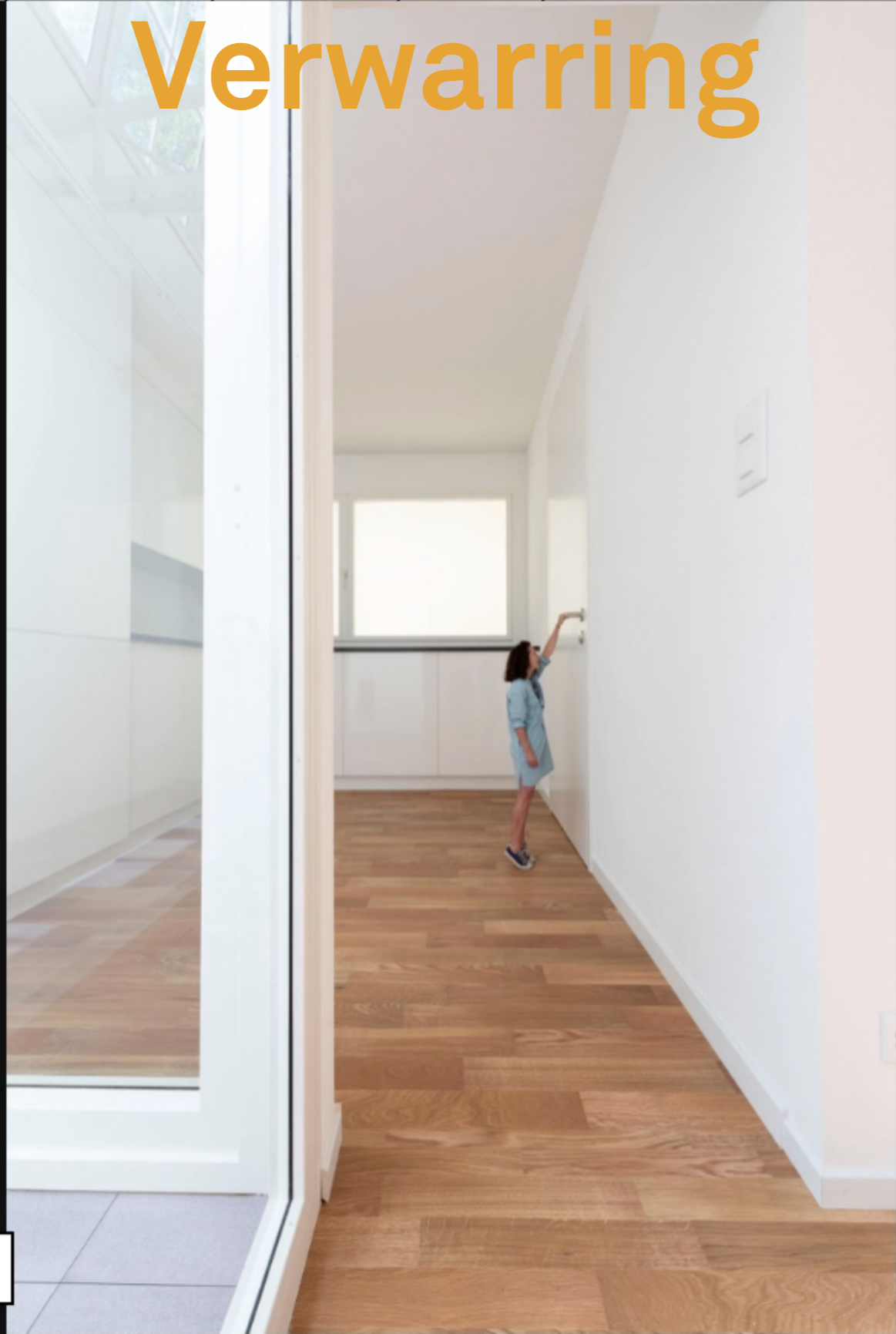

House Tour
Alessandro Bosshard, Li Tavor, Matthew van der Ploeg, Ani Vihervaara

The swiss pavilion of the Venice Biennale 2018. 'Alice in wonderland' experience

- Imagination
- Confusion
- Body Movement
- Contrast in Shape
- Architecture
- Installation Art

Kinetic: Static
 Size: Building
 Placement: Inside
 Timeframe: Temporary
 Relation: Participant
 Year: 2018
 Location: Venice
 Source: External link



Nieuwsgierigheid



Oase No. 7
Haus Rucker & Co

Designed as part of the Documenta 5 exhibition in Kassel, 1972. A transparent pneumatic sphere with a diameter of 8 meters, is a space for relaxation and play. It is a performance where the viewers become participants and could influence their own environments becoming more than on lookers. (like in Carsten Holler test site)

Imagination Curiosity

View Body Movement Contrast in Shape Air

Contrast in Material

Parasite Installation Art

Kinetic: Static
 Size: Installation
 Placement: Outside
 Timeframe: Temporary
 Relation: Participant
 Year: 1972
 Country: Germany
 Location: Kessel

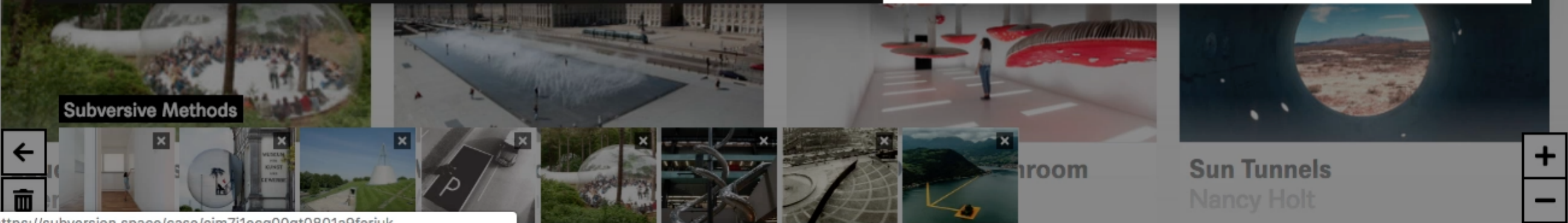

CASES MANIFESTO METHODS ABOUT

Filter Wonder X Body Movement X

Search

Order by: Date added

Onderbreking



Staircase of TU Delft Library Mecanoo

Lazy staircase to the entrance on which you can not walk comfortably and are forced to slow down.

- Disruption
- Body Movement
- Landmark
- Architecture

- Kinetic: Static
- Size: Building
- Placement: Outside
- Timeframe: Permanent
- Relation: Participant
- Country: The Netherlands
- Location: Delft

Subversive Methods

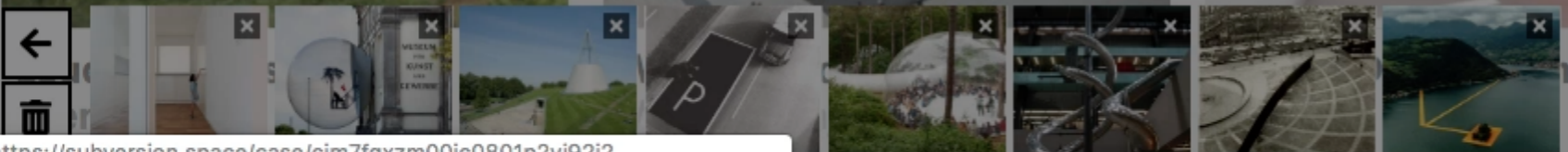

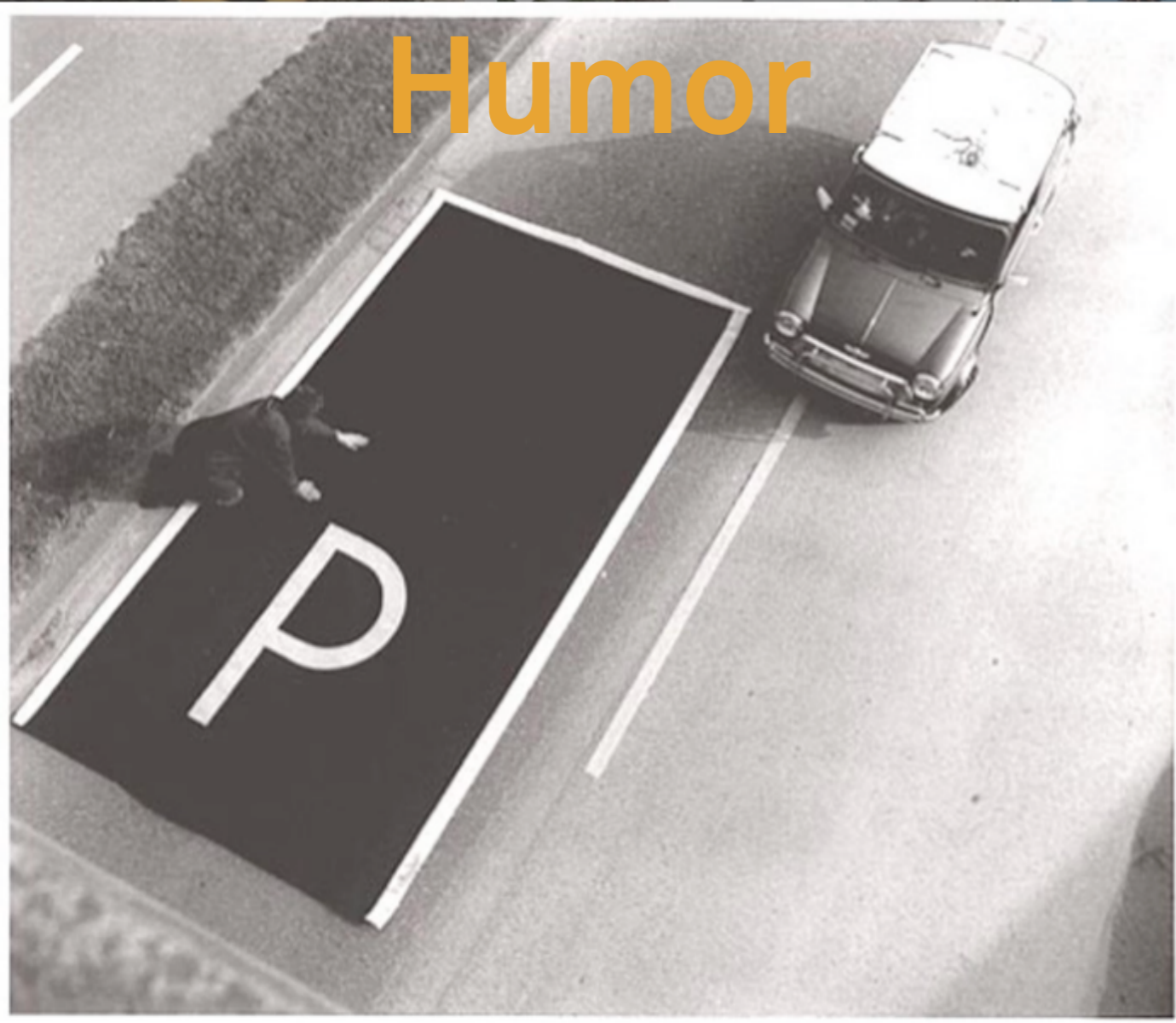

Humor

Parkeer Kleed John Körmeling

Rollable parking spot, so you can park your car everywhere. Using humor to look at a problem differently, turning it around

- Provoke
- Humour
- Art
- Conceptual Art

- Kinetic: Static
- Size: Object
- Placement: Outside
- Timeframe: Temporary
- Relation: Spectator
- Country: The Netherlands

Subversive Methods

room

Sun Tunnels
Nancy Holt

https://subversion.space/case/cjmrh6axr00bv0824njzfd8p6

CASES MANIFESTO METHODS ABOUT

Filter Wonder x Body Movement x

Search

Order by: Date added

Verbeelding

Loud Shadows - Liquid Events Plastique Fantastique

"Plastique fantastique has presented a monumental design, yet mobile, soft, and transparent. Its skin influences the environment as much as its inner space offers a clear view outwards. Its purpose is to create an intimate place where dance and music is merged, and the perception of time is challenged." Installation at Oerol 'Loud Shadows' 2017.

Wonder Imagination Play

Body Movement Contrast in Shape Contrast in Material

Installation Art

Kinetic: Dynamic
 Size: Installation
 Placement: Outside
 Timeframe: Temporary
 Relation: Participant
 Year: 2017
 Country: The Netherlands
 Source: External link

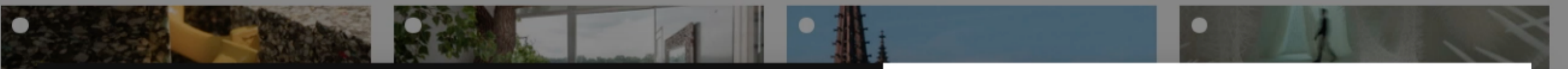

Subversive Methods

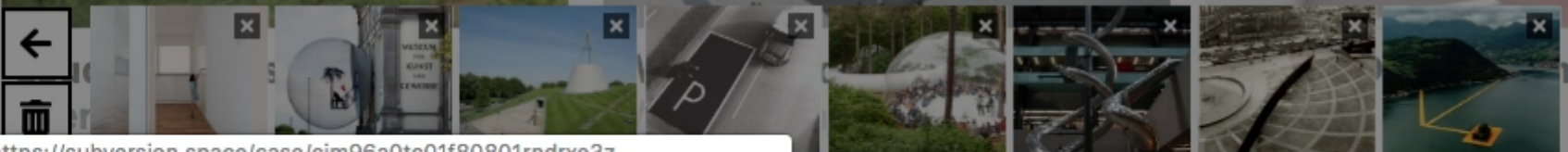

room

Sun Tunnels
Nancy Holt

Speelsheid



Test Site Carsten Höller

An installation test site for the incorporation of slides in daily life. 'A device for experiencing an emotional state that is a unique condition somewhere between delight and madness.'

- Imagination
- Play
- Body Movement
- Art
- Relational Art

Kinetic: Static
 Size: Installation
 Placement: Inside
 Timeframe: Temporary
 Relation: Participant
 Year: 2006
 Location: Tate, London
 Source: External link

Provocative



Tilted Arc Richard Serra

Richard Serra placed a giant tilted arc on the Federal Plaza in New York. It was 12 feet high and 120 feet long, and leaned slightly to one side. "It was immediately seen as ugly, oppressive and a 'graffiti catcher'. Two petitions seeking the removal of the piece quickly gathered 1,300 signatures." The sculpture was removed after 8 years.

Provoke Disruption

Body Movement

Art Intervention Art

Kinetic:	Static
Size:	Installation
Placement:	Outside
Timeframe:	Temporary
Relation:	Participant
Year:	1981
Country:	U.S.A.
Location:	New York
Source:	External link ↗

Verwondering



Floating Piers Cristo & Jeanne-Claude

A orange coloured walkway that connects two islands in a lake in Northern Italy. Walking over it will make you feel as if walking over water, as it slowly moves up and down on the waves. It is made from fabric.

- Wonder
- Imagination
- Body Movement
- Nature
- Water
- Land Art
- Installation Art

- Kinetic: Dynamic
- Size: Structure
- Placement: Outside
- Timeframe: Temporary
- Relation: Participant
- Country: Italy
- Location: Lake Iseo

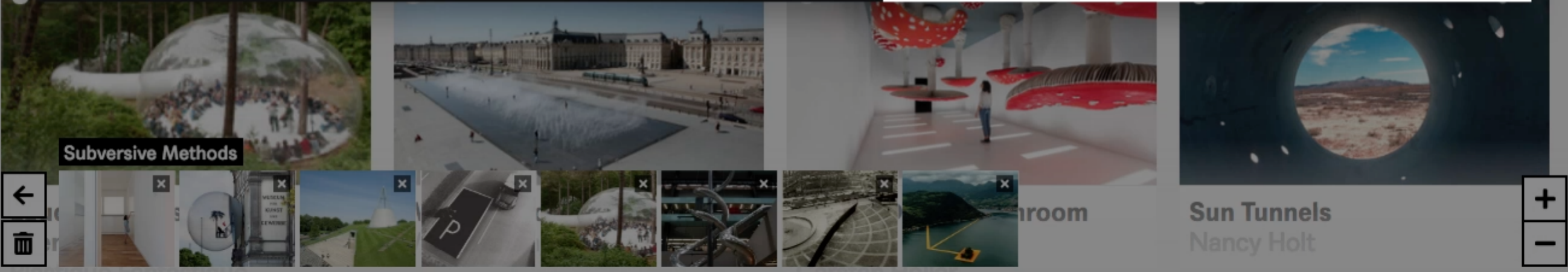

Subversive Methods

Sun Tunnels
Nancy Holt

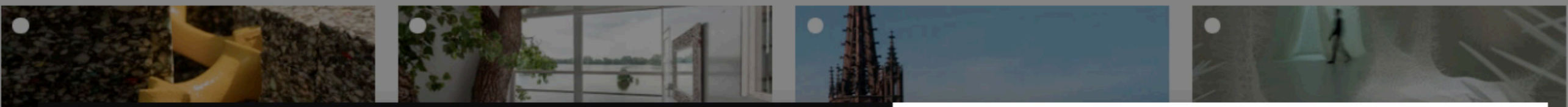

Floating Piers

Cristo & Jeanne-Claude

A orange coloured walkway that connects two islands in a lake in Northern Italy. Walking over it will make you feel as if walking over water, as it slowly moves up and down on the waves. It is made from fabric.

- Wonder
- Imagination
- Body Movement
- Nature
- Water
- Land Art
- Installation Art

- Kinetic: Dynamic
- Size: Structure
- Placement: Outside
- Timeframe: Temporary
- Relation: Participant
- Country: Italy
- Location: Lake Iseo

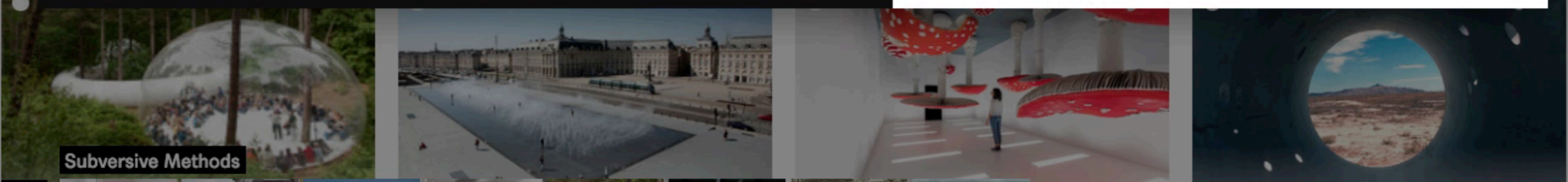

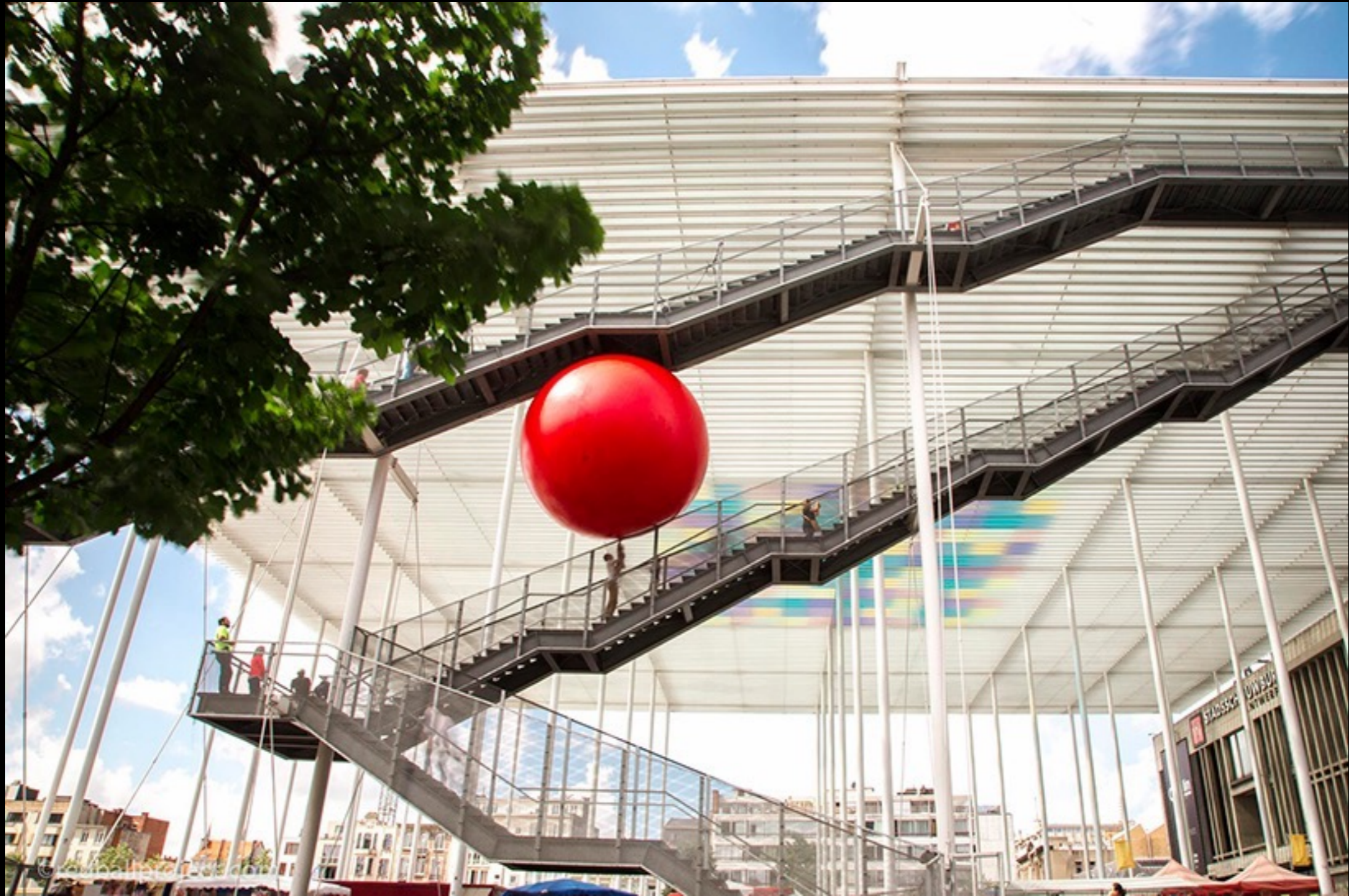

The Red Ball Project, Kurt Perschke, 2016

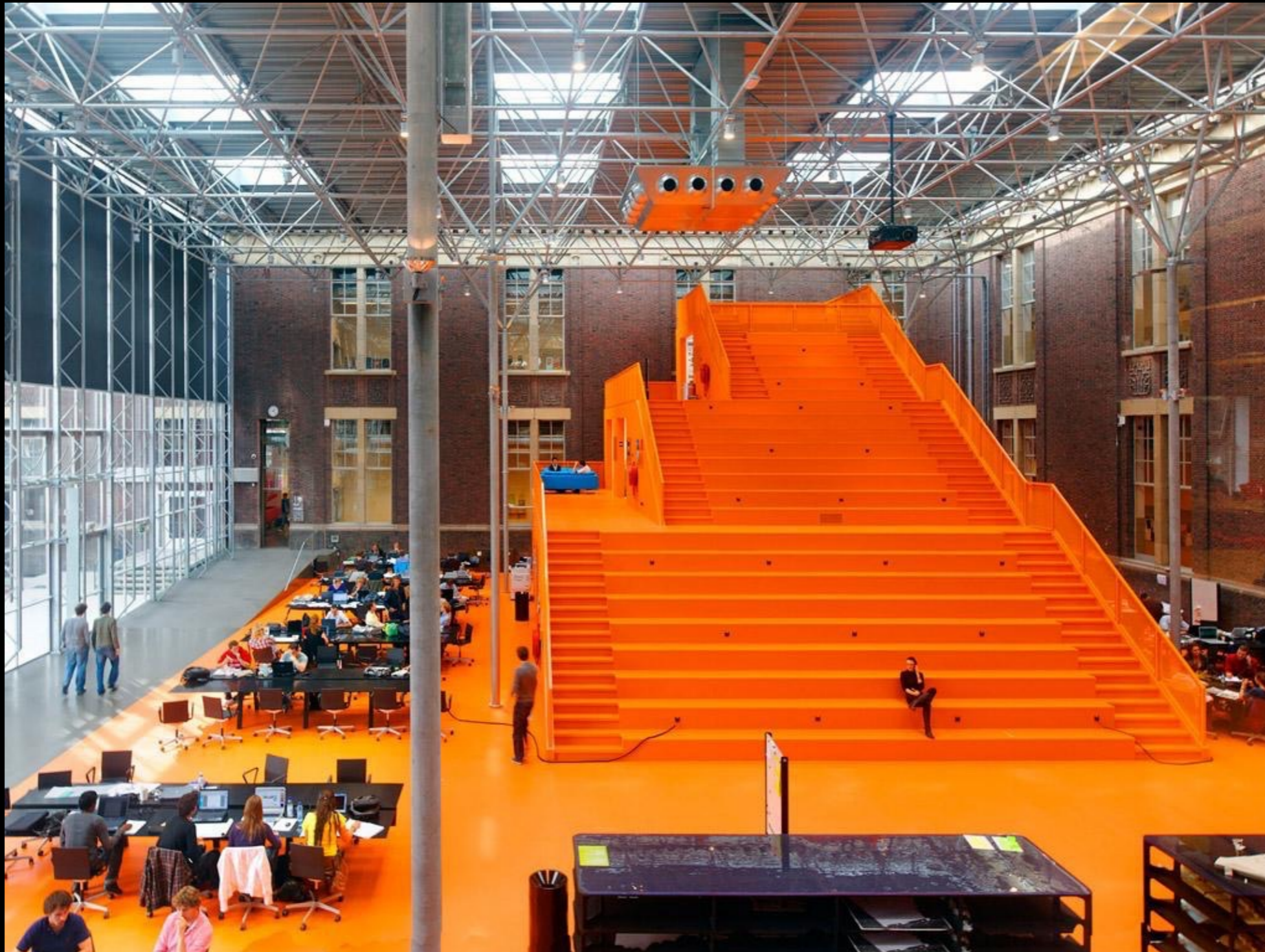

Why Factory tribune, MVRDV, 2009

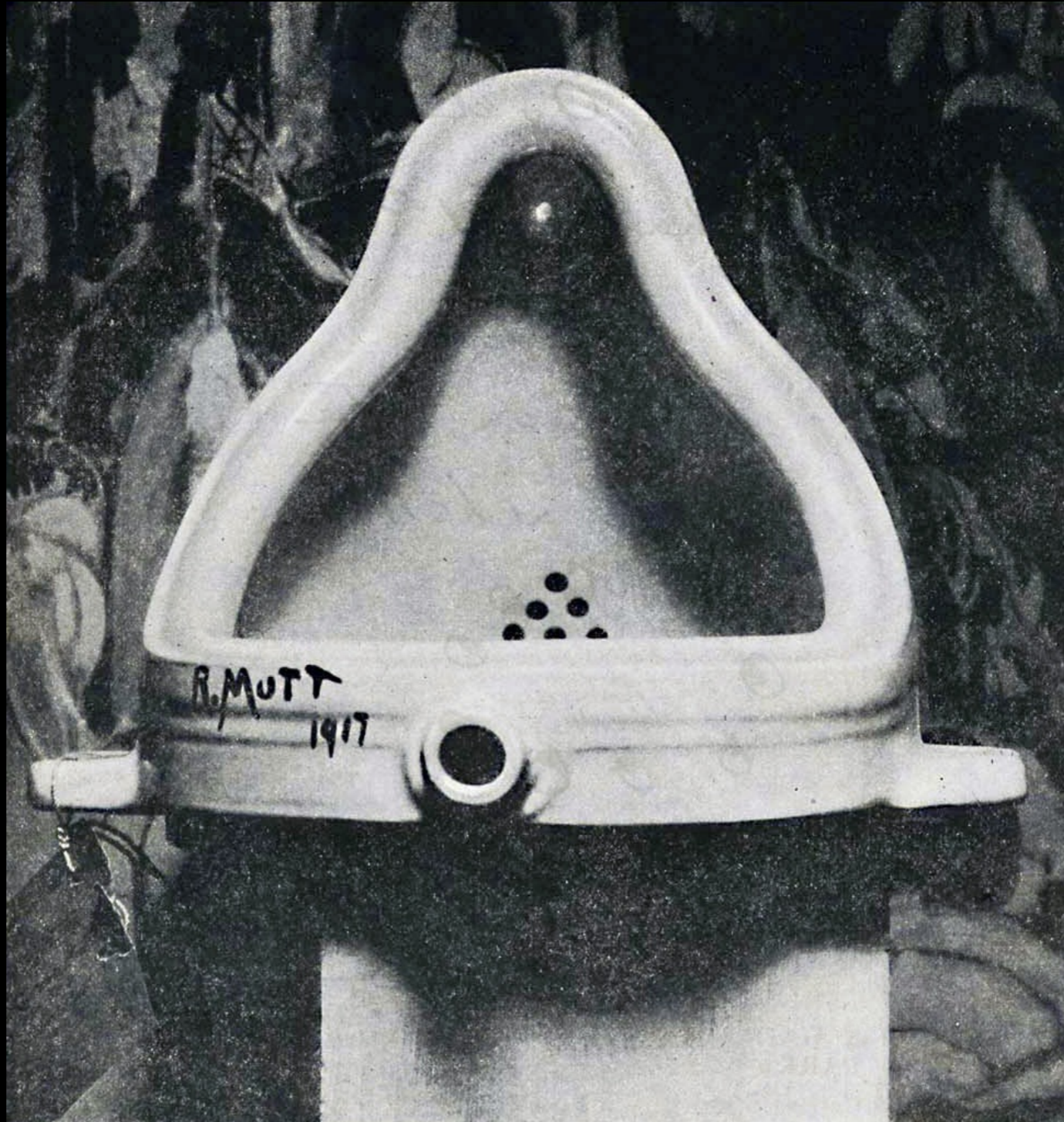

Fountain, Elsa von Freytag, 1917

Rotterdam



Rotterdam

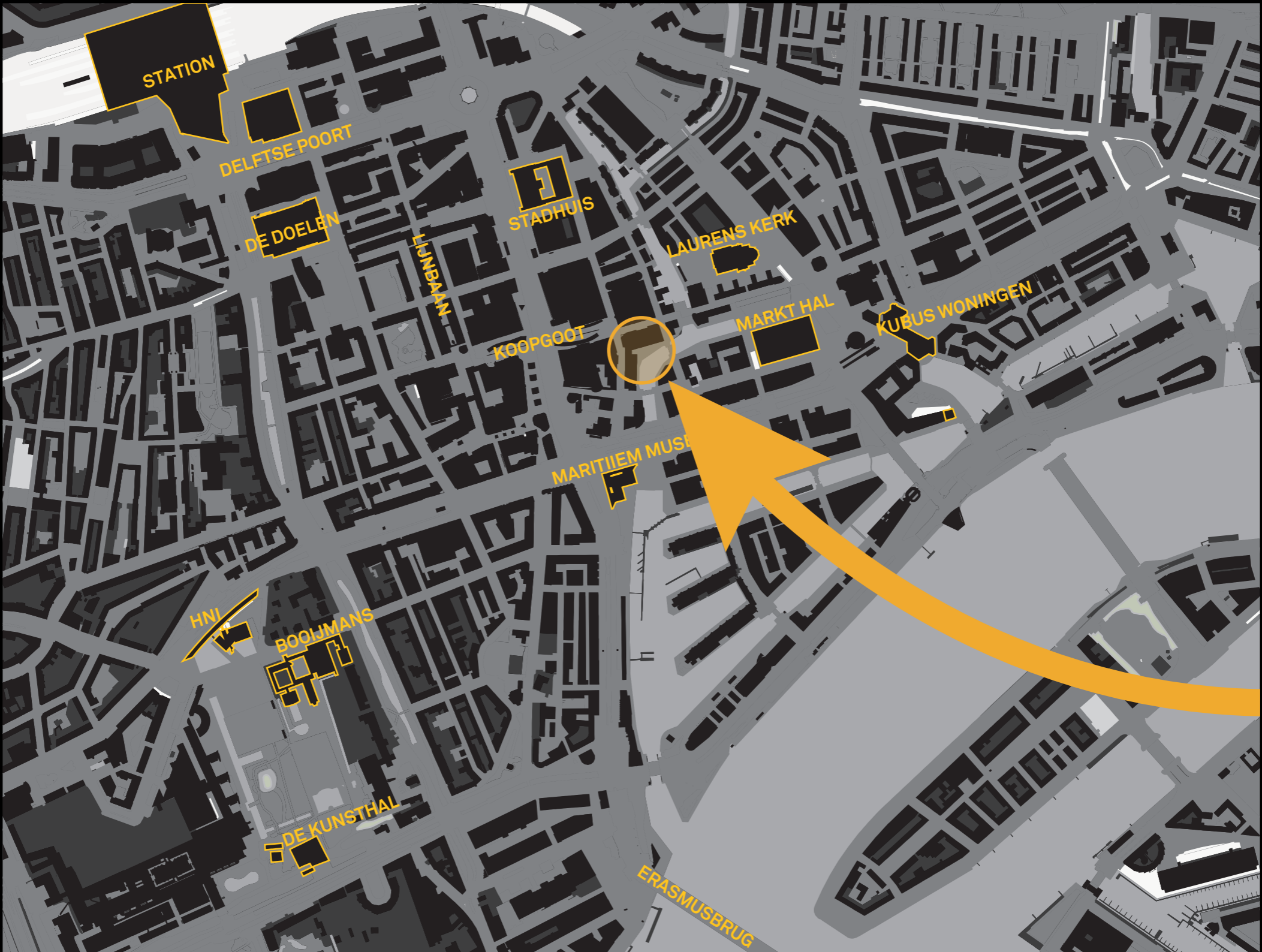

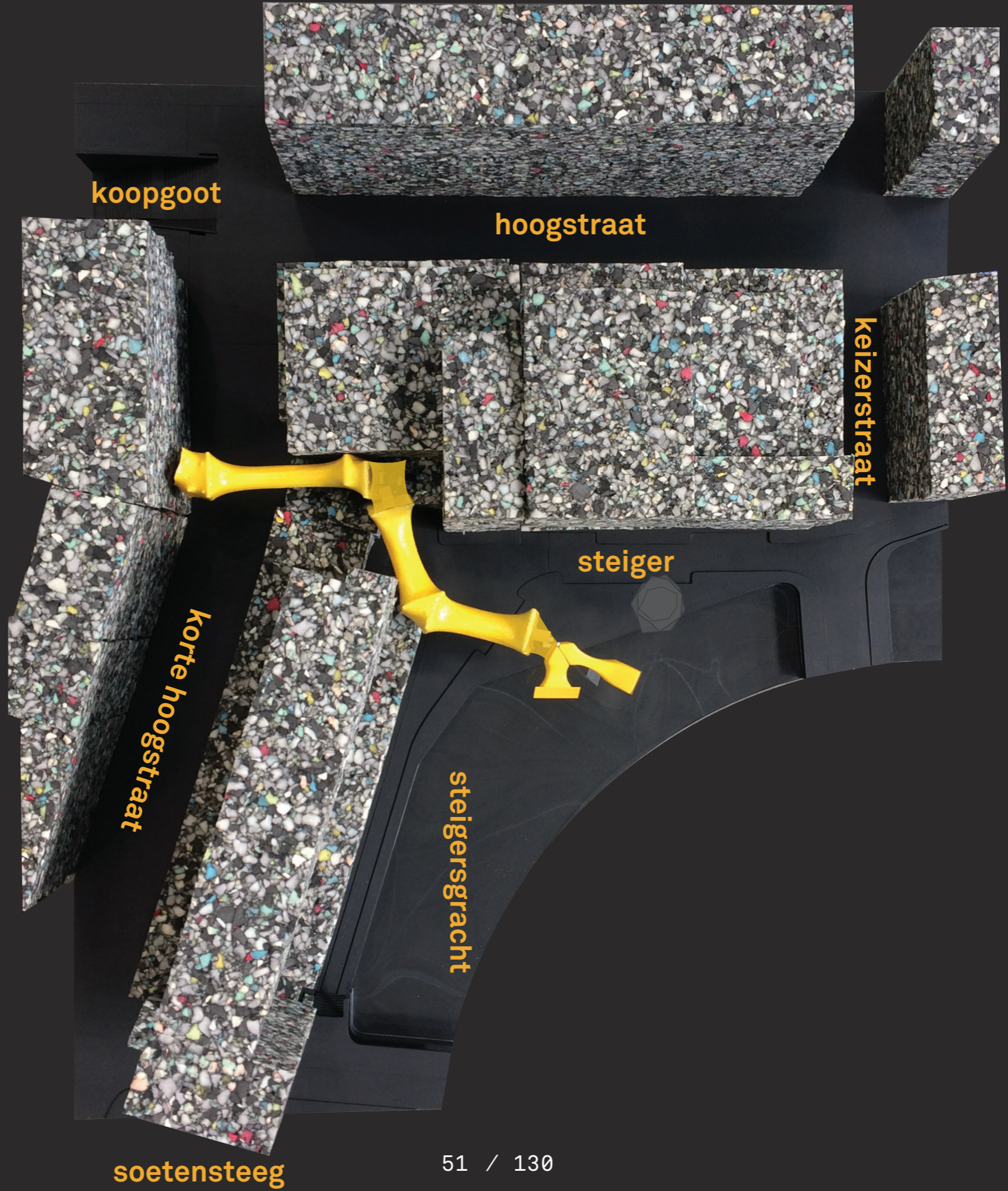

koopgoot

hoogstraat

keizerstraat

steiger

steigersgracht

korte hoogstraat

soetensteeg

**ontwerp opdracht =
tijdelijk openbaar toilet die
verwachtingen ondermijnd**
(waardoor de locatie word geactiveerd)

toepassing

analyse

Verwarring

Nieuwsgierigheid

Onderbreking

Humor

Verbeelding

Speelsheid

Provocatie

Verwondering

analyse

context

route

toilet unit

context

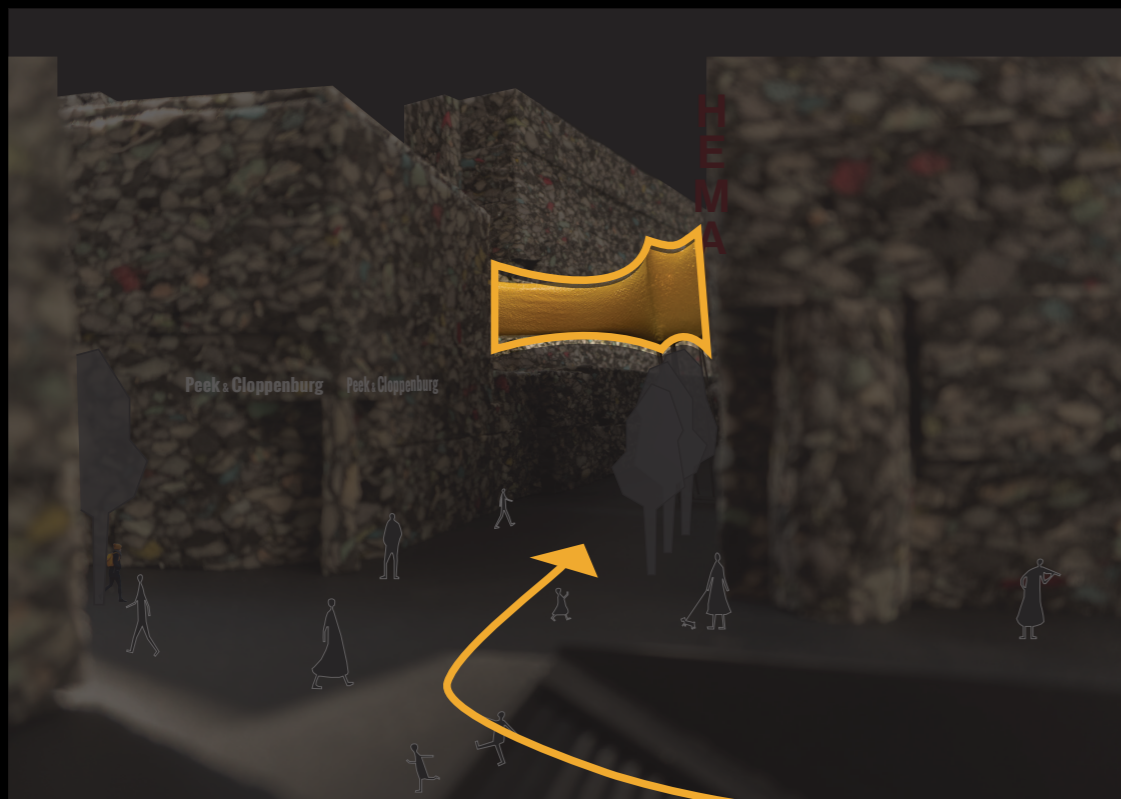

nieuwsgierigheid

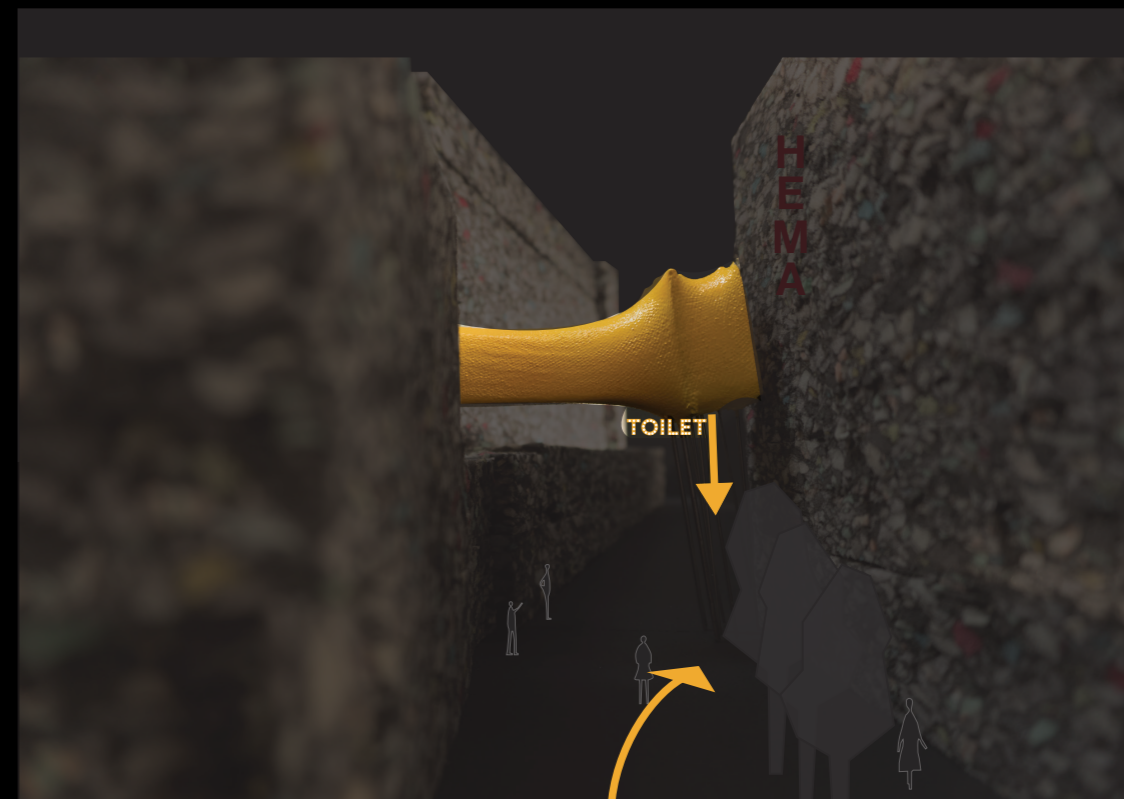

nieuwsgierigheid

context



verwarring

route



nieuwsgierigheid & verwarring

route



onderbreking

route



nieuwsgierigheid & verwarring

route

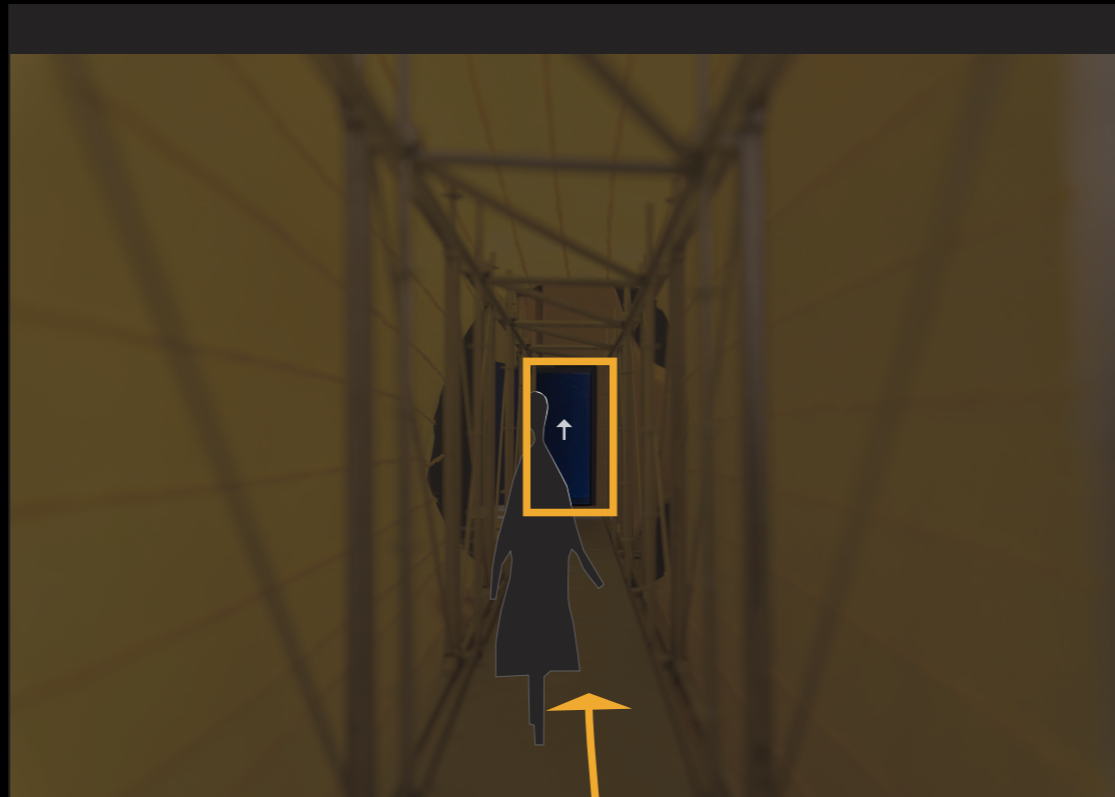

nieuwsgierigheid

toilet unit

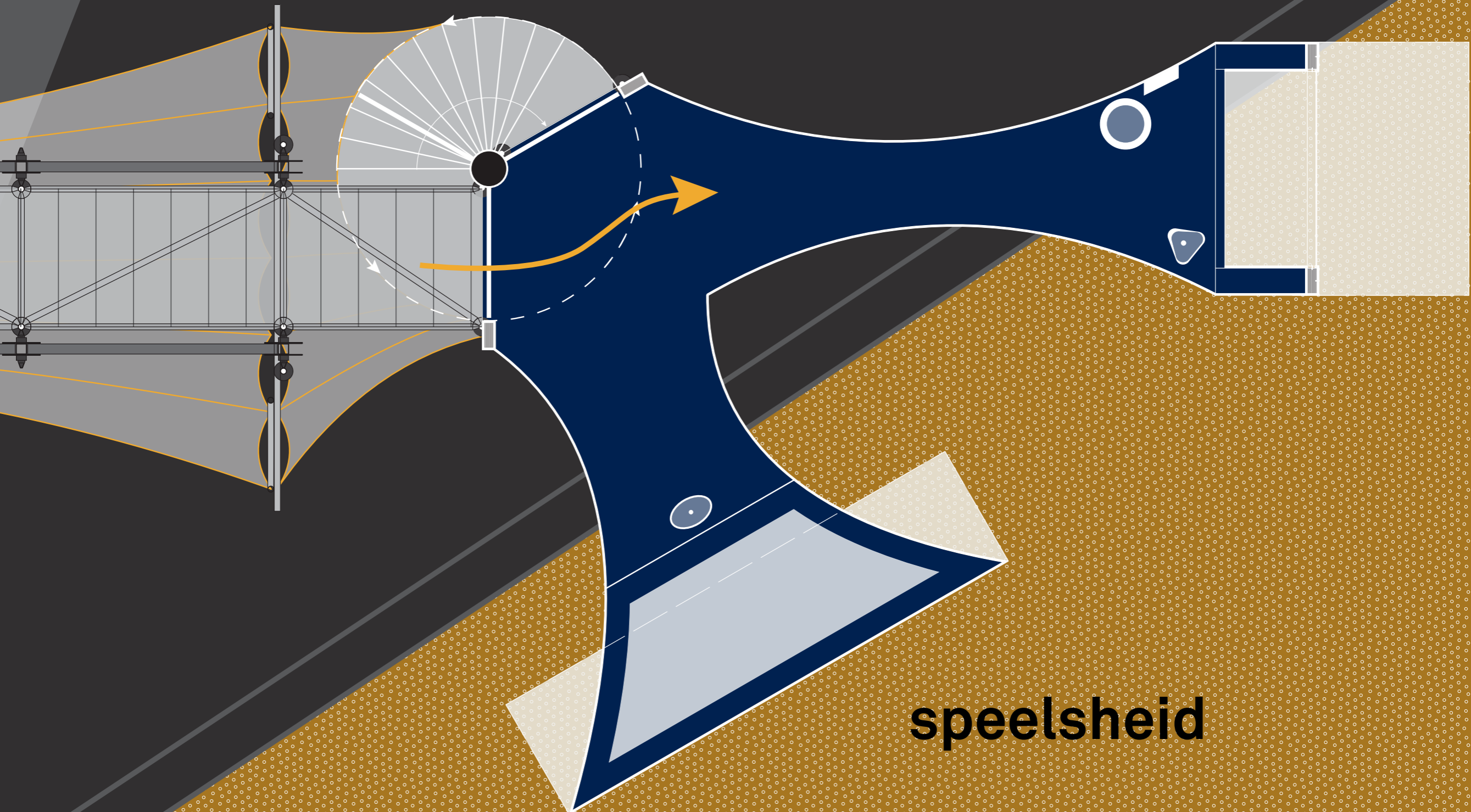

speelsheid

toilet unit

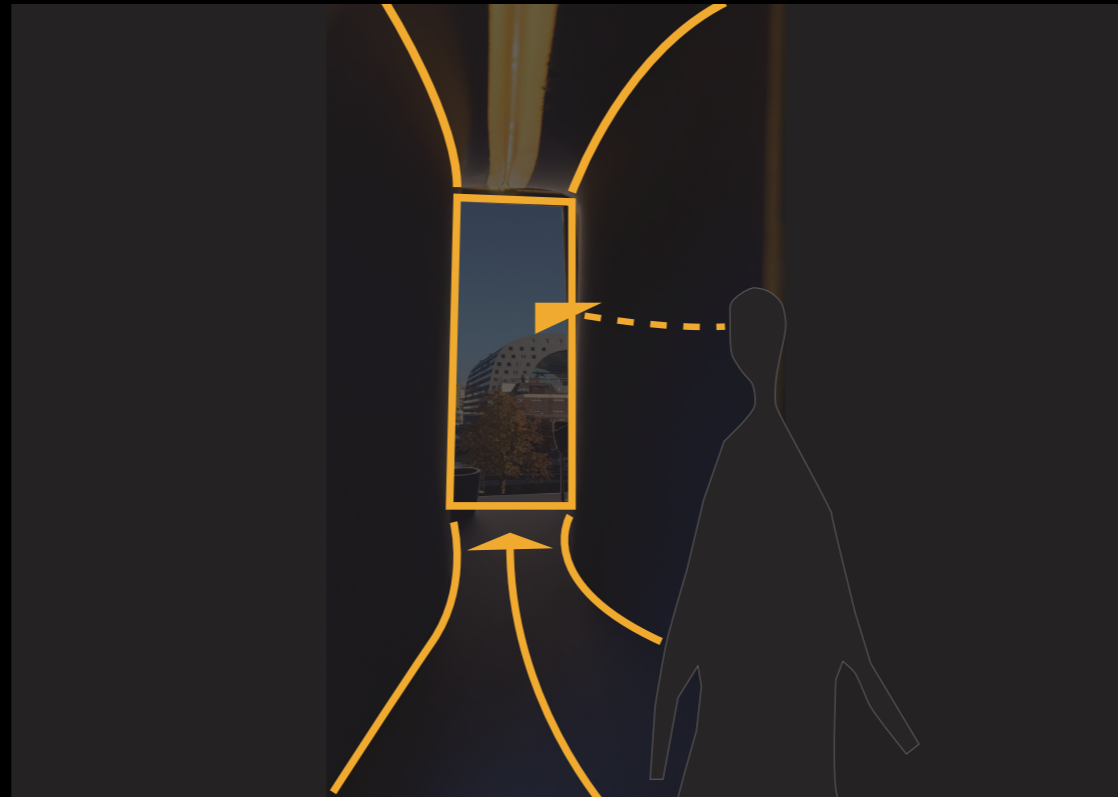

verwondering en verbeelding

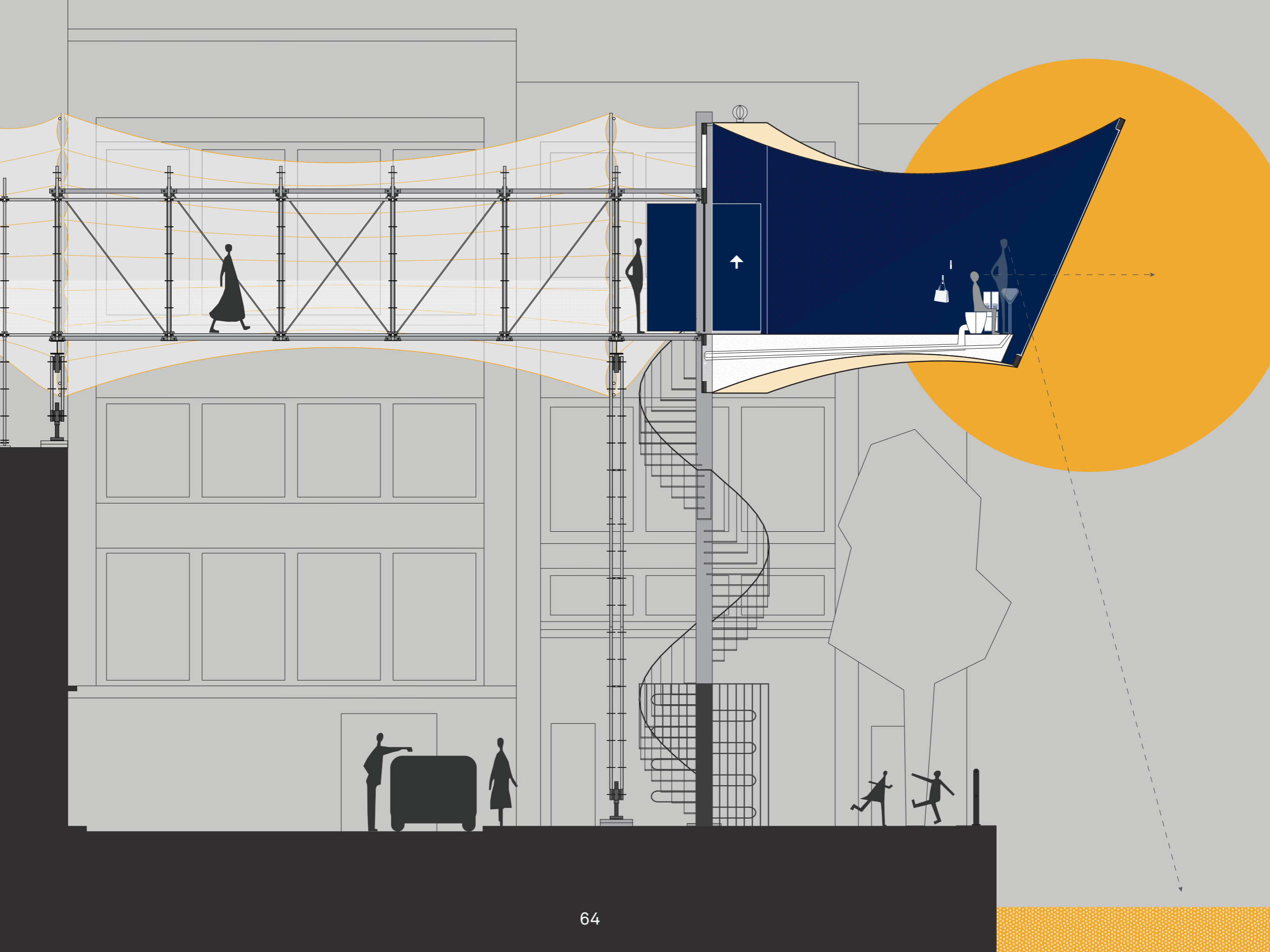

toilet unit



speelsheid en humor

toilet unit



provocatie

toilet unit



toilet unit

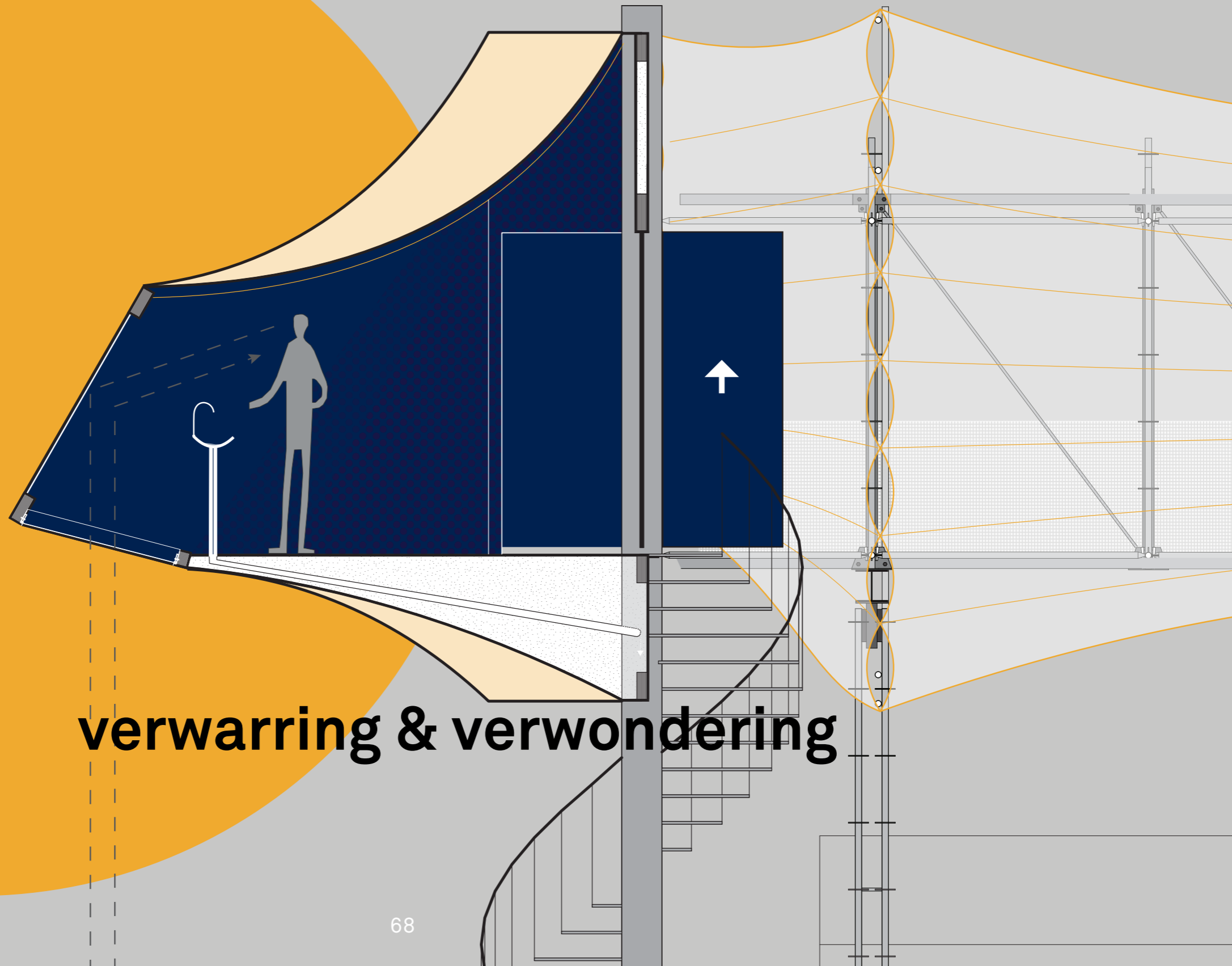

verwarring & verwondering

toilet unit

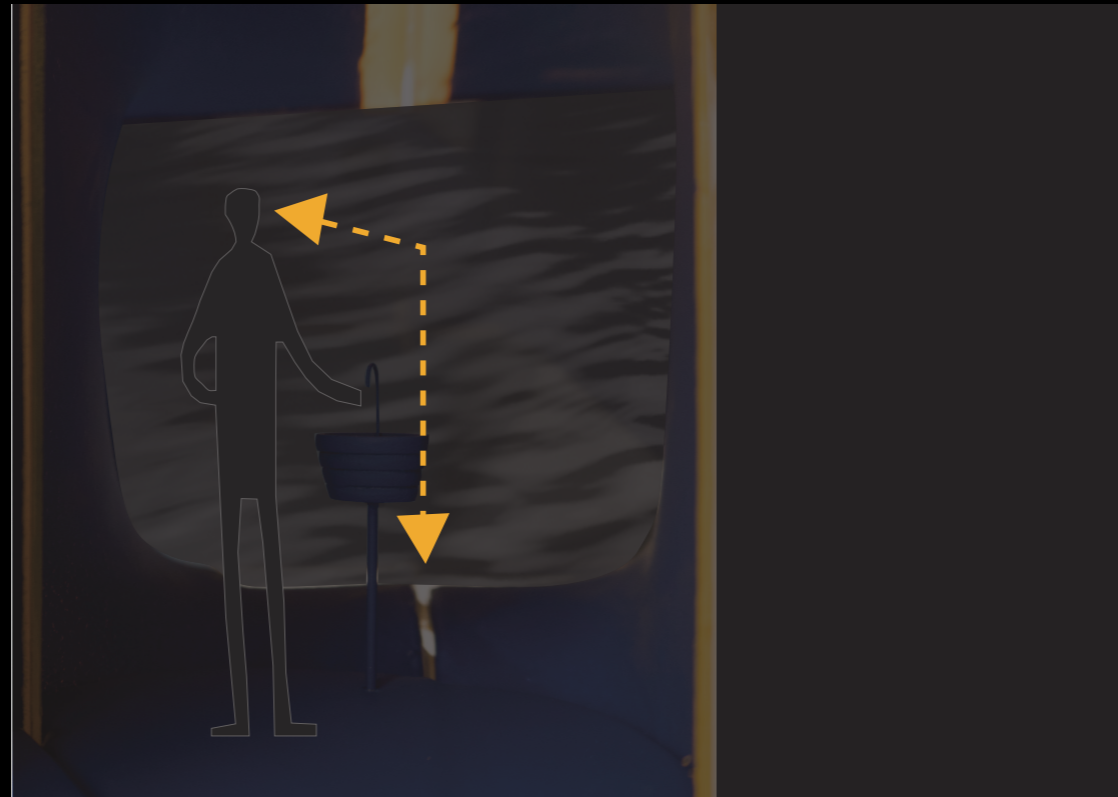

verwarring en verwondering

toilet unit

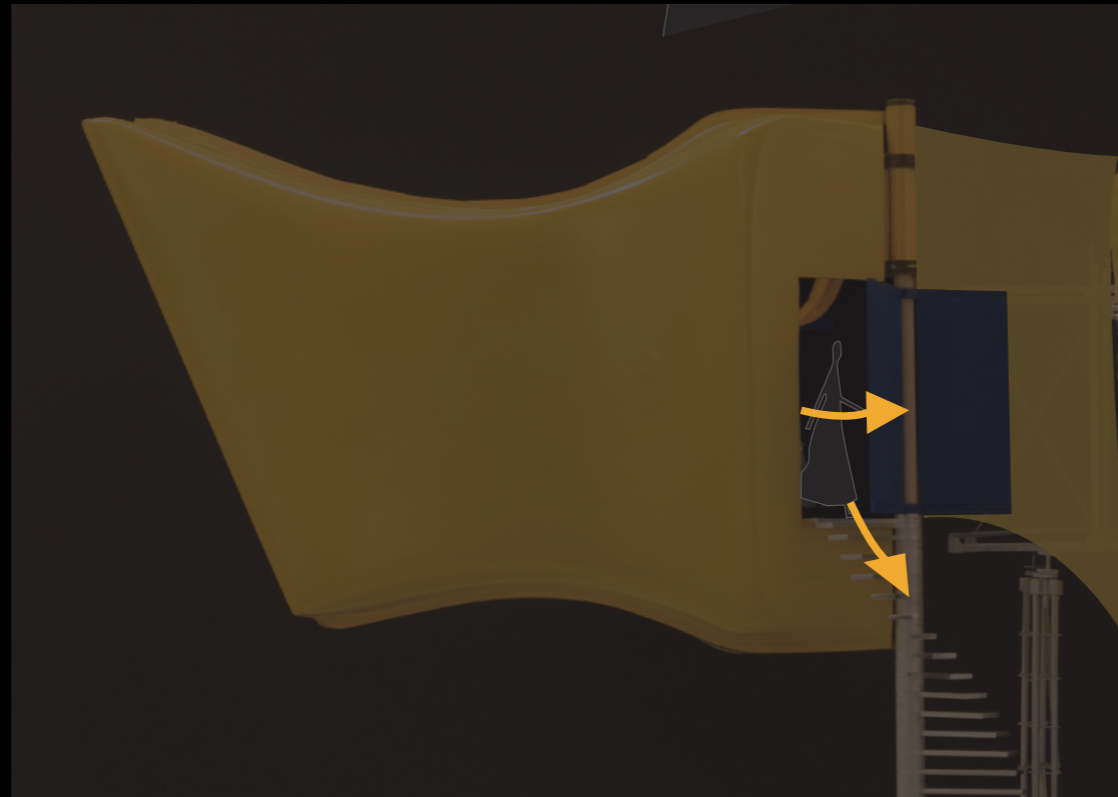

speelsheid & onderbreking

context



teleportatie gevoel

context

onderbreking

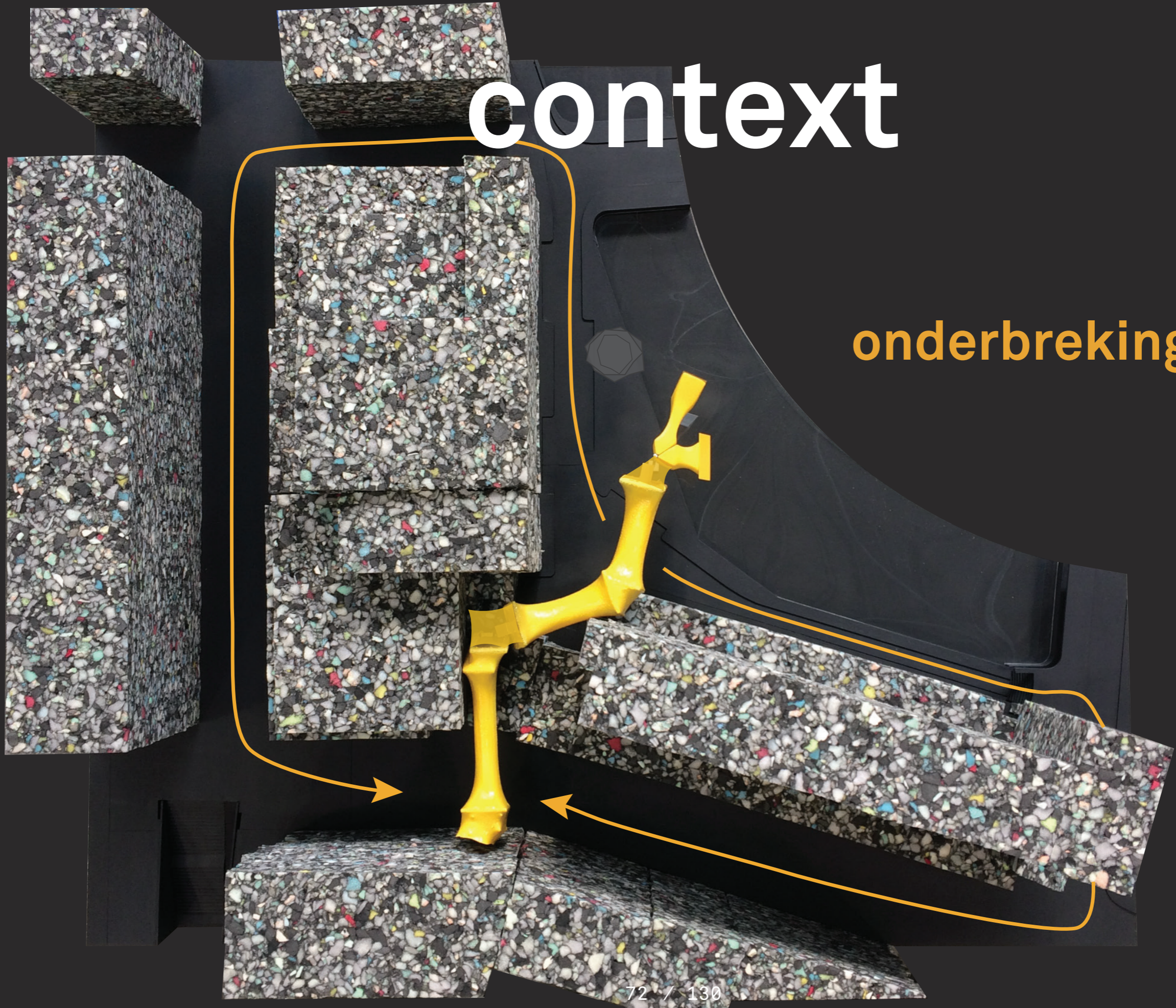

context



verbeelding

context



context



uitwerking

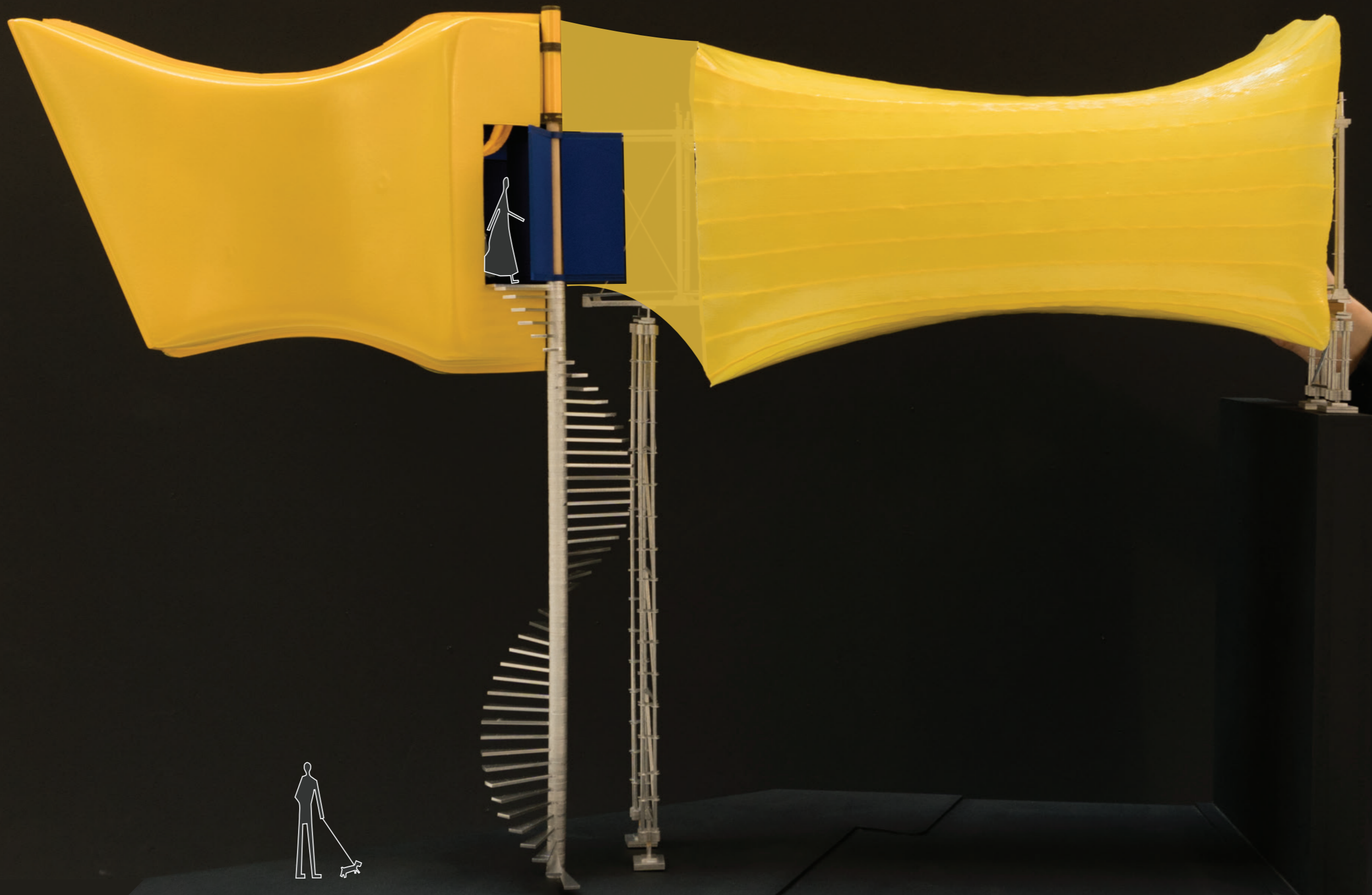

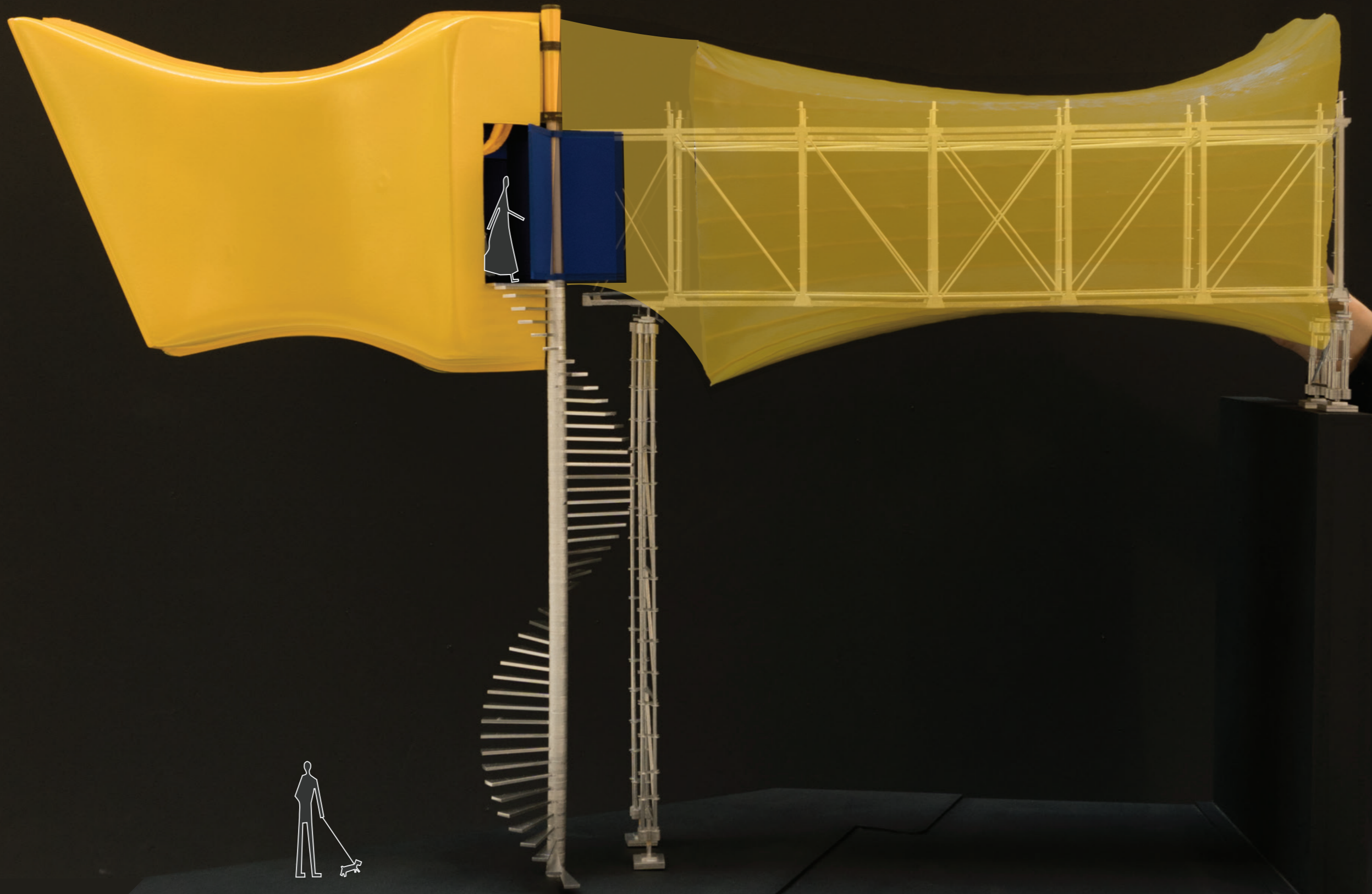

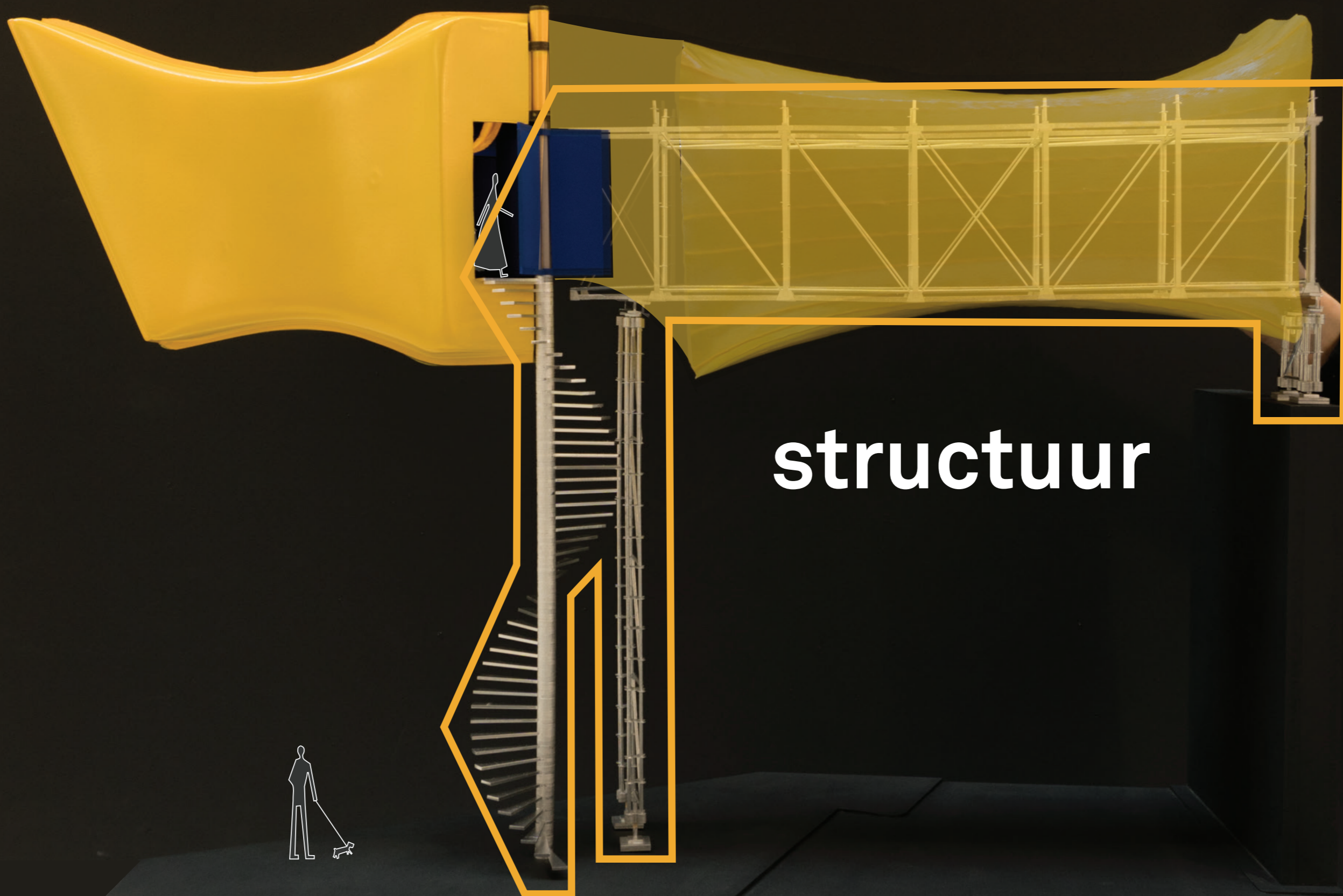

structuur



toilet unit



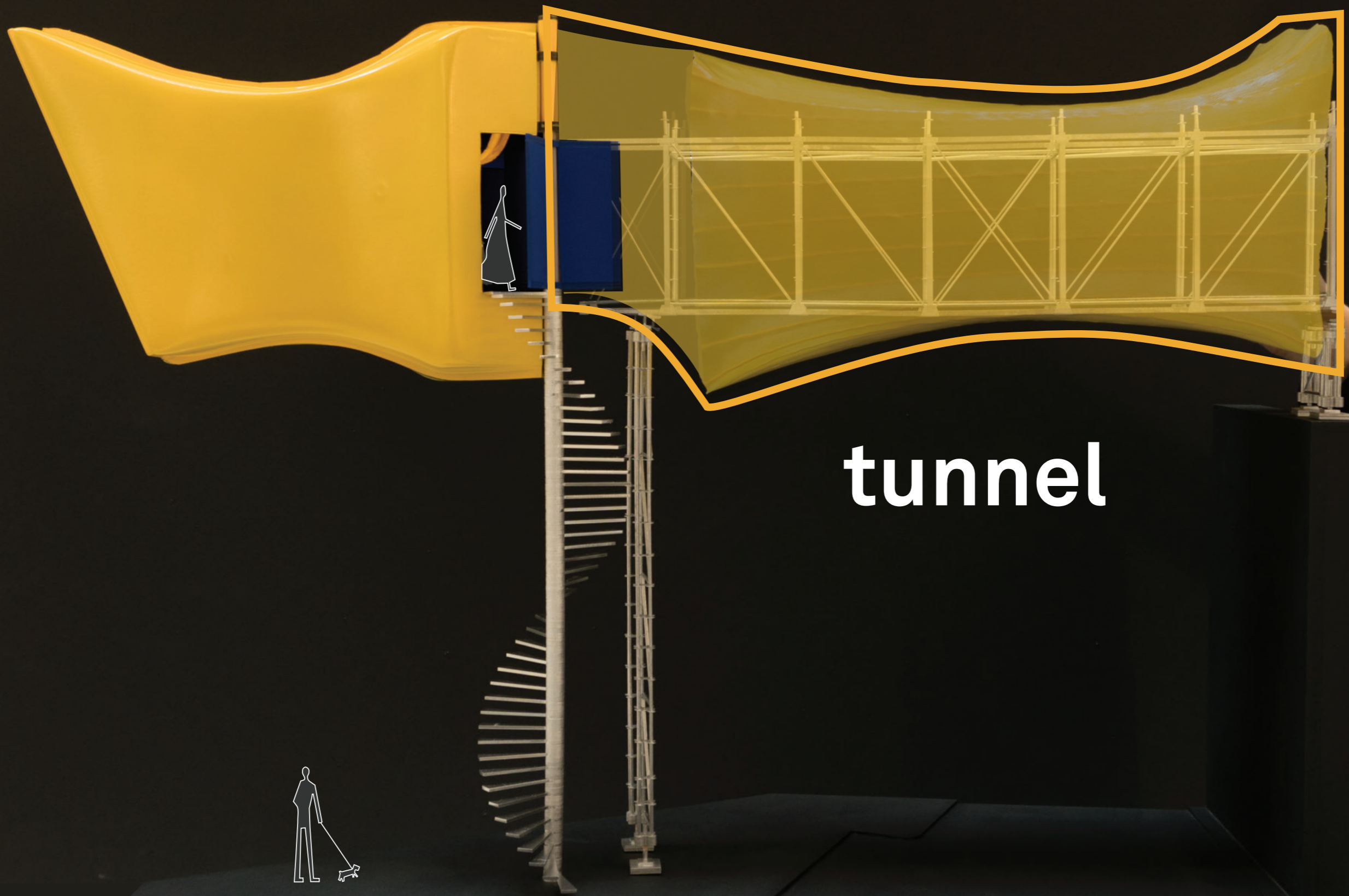

tunnel



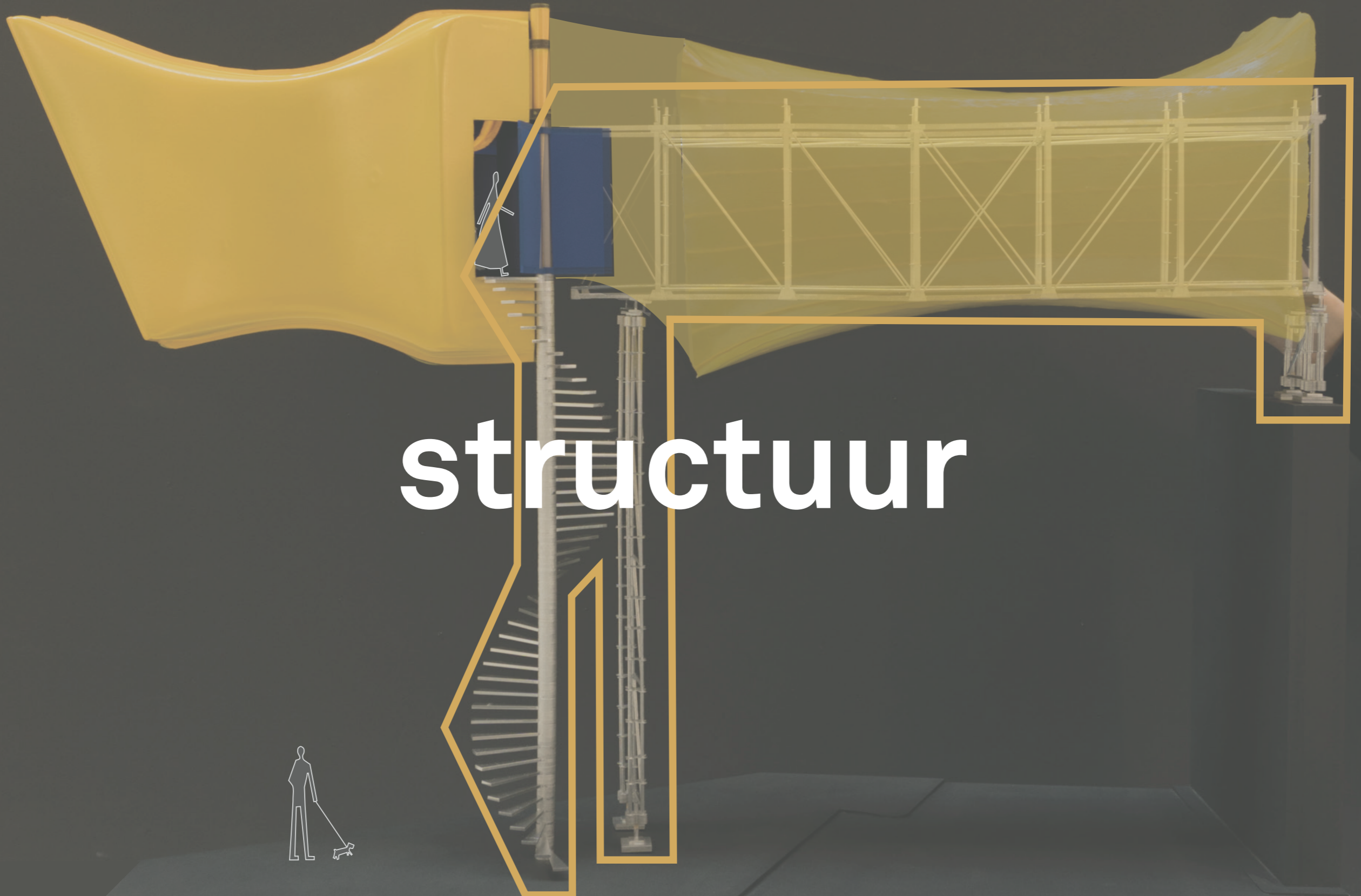

structuur



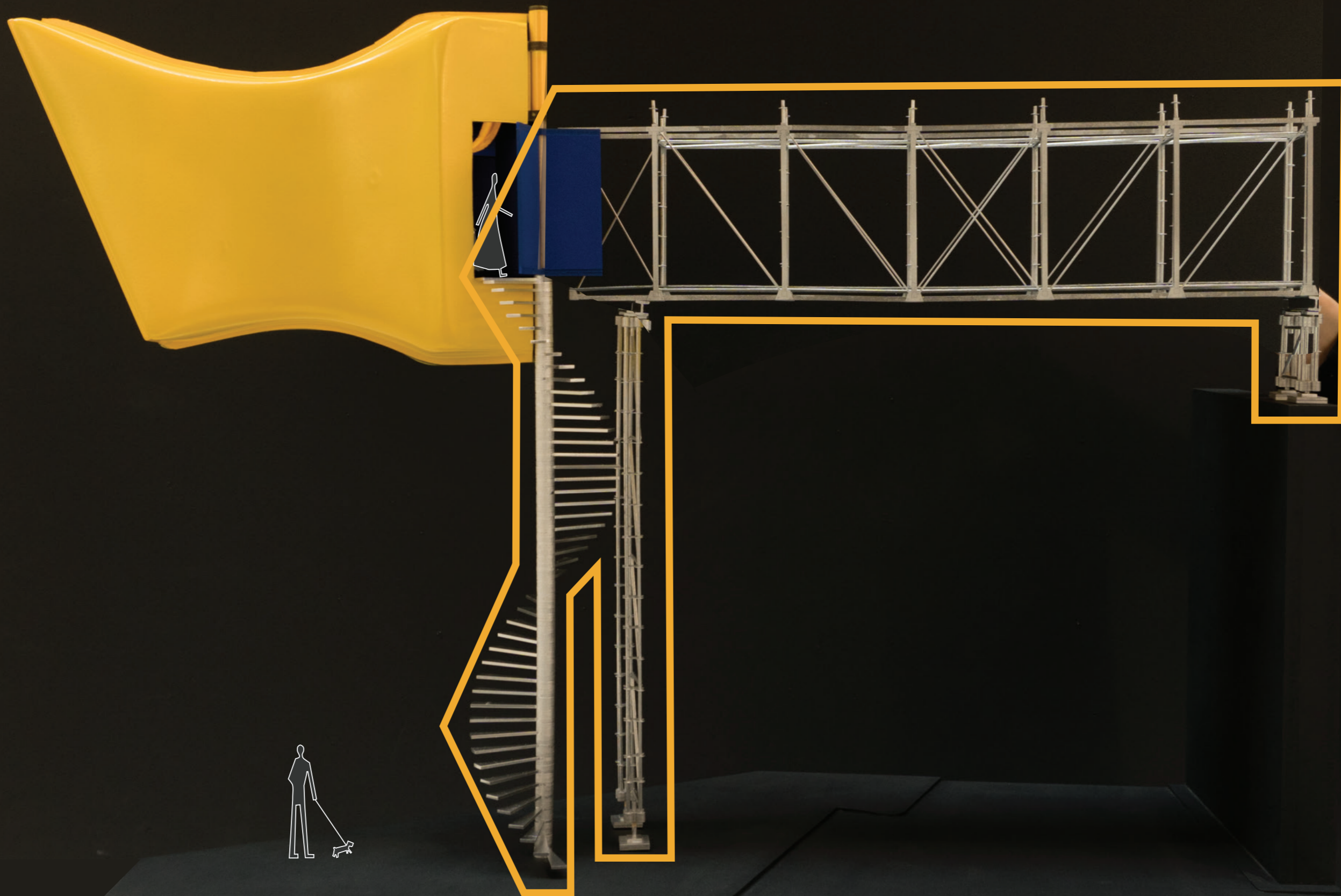

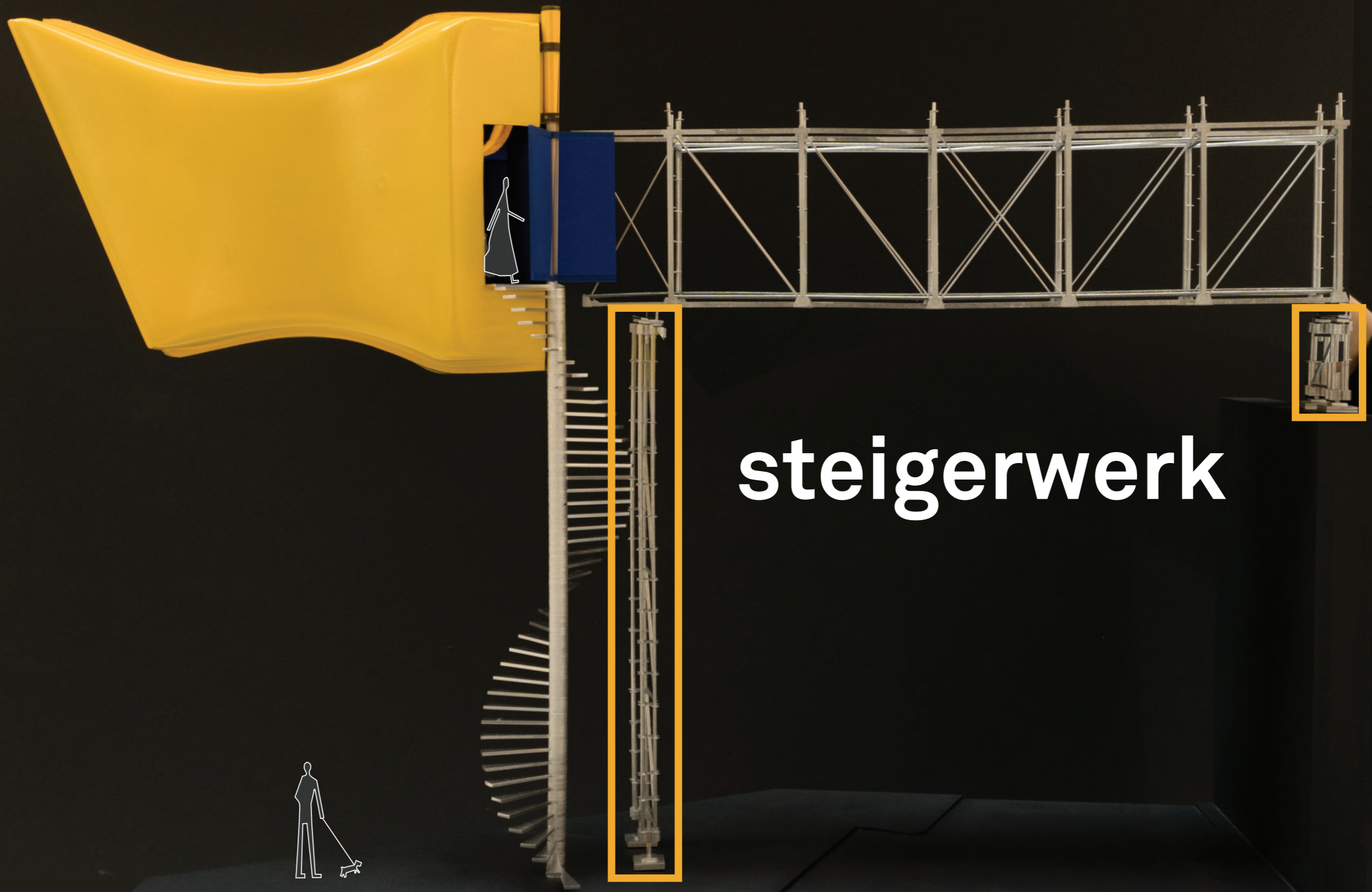

steigerwerk

brug

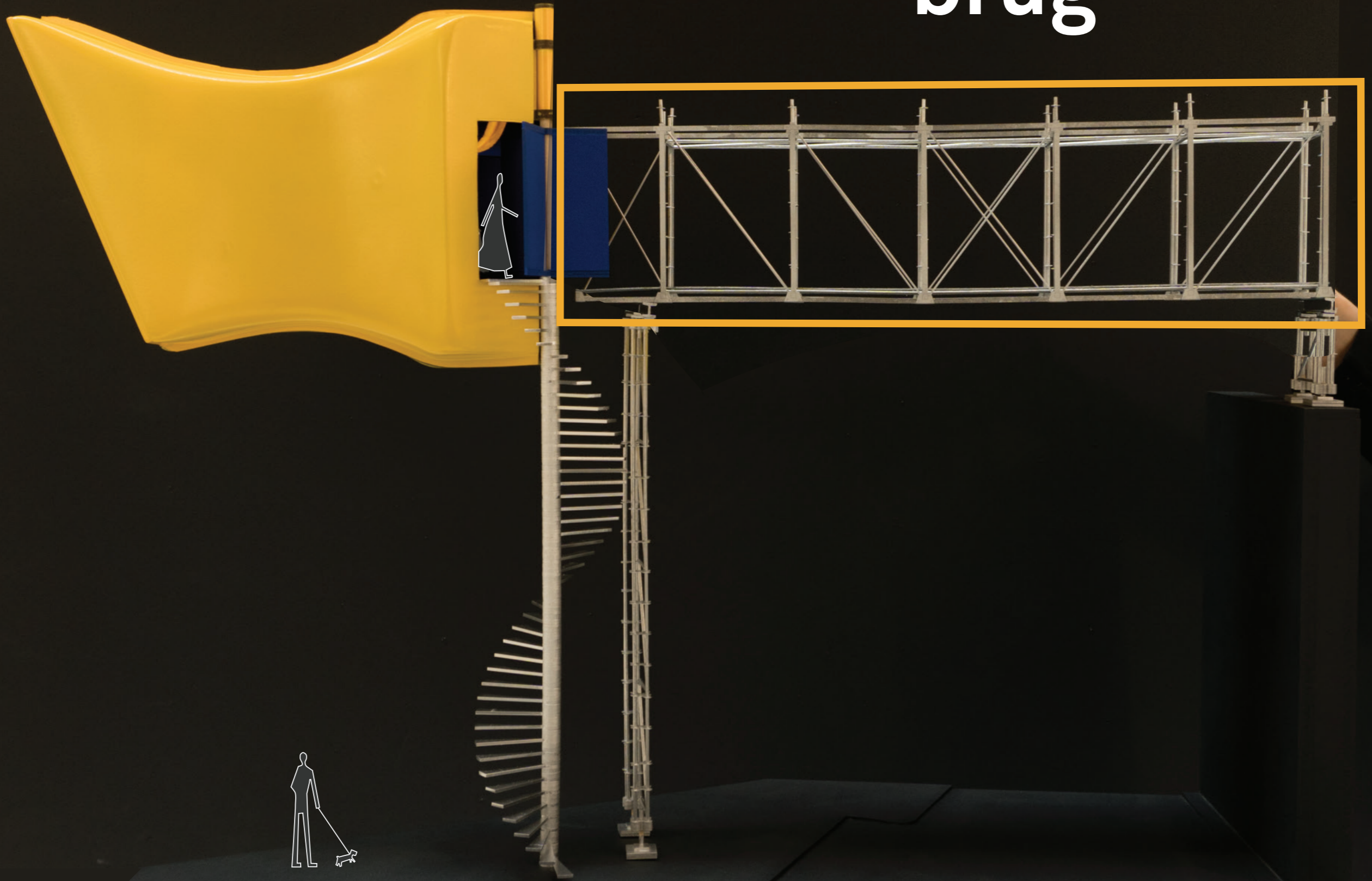

trap



steigerwerk

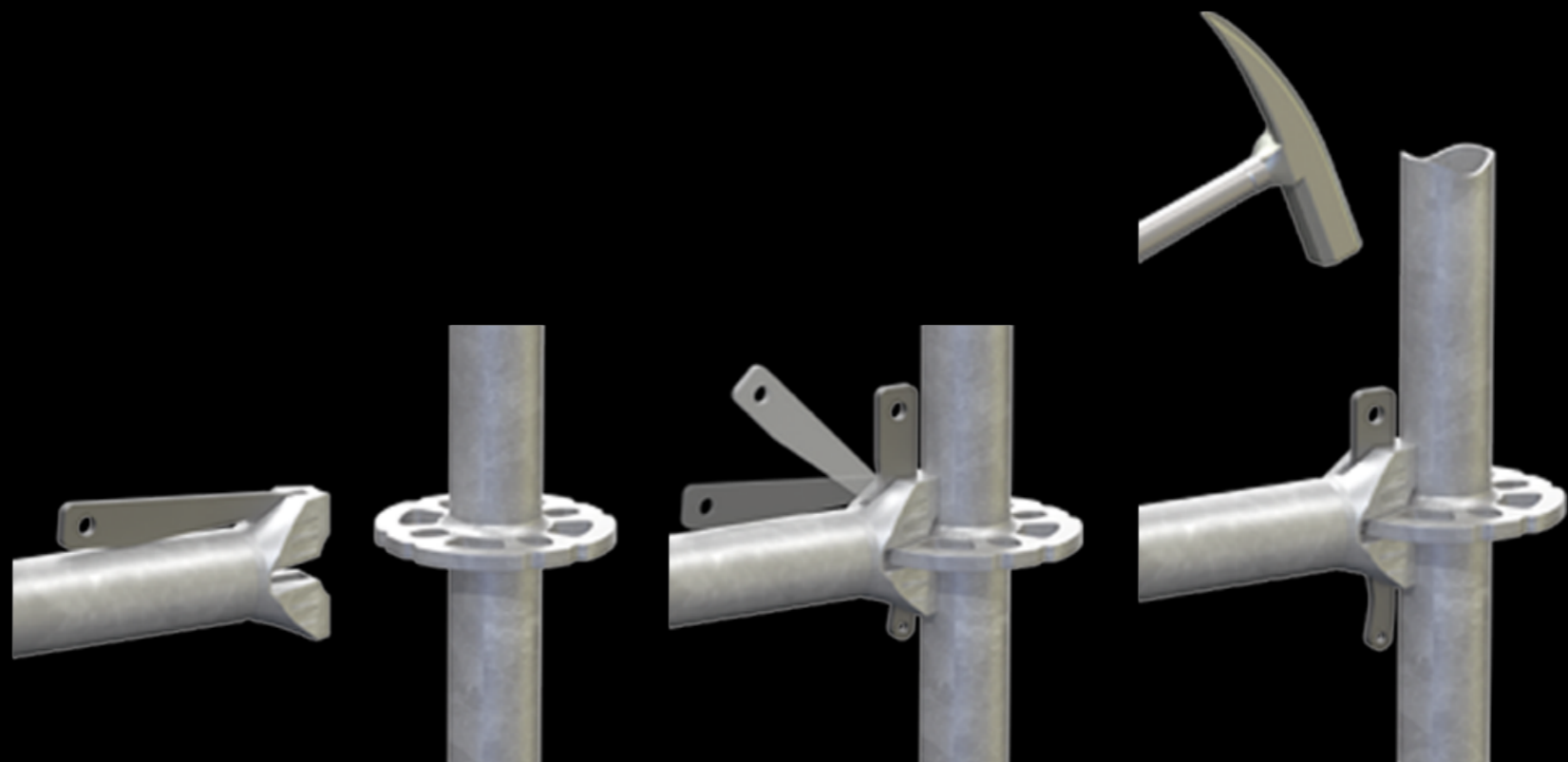
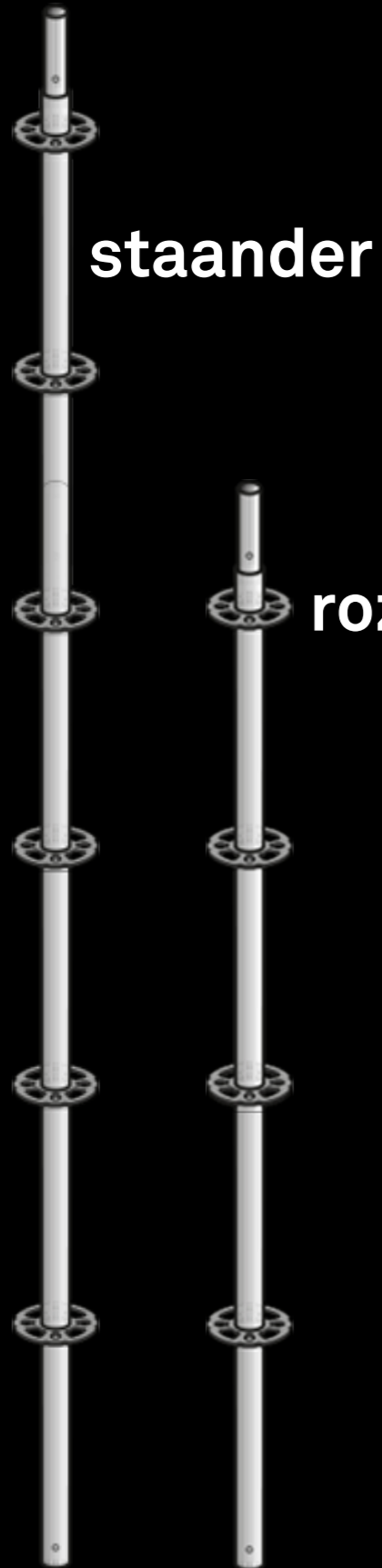

steigerwerk

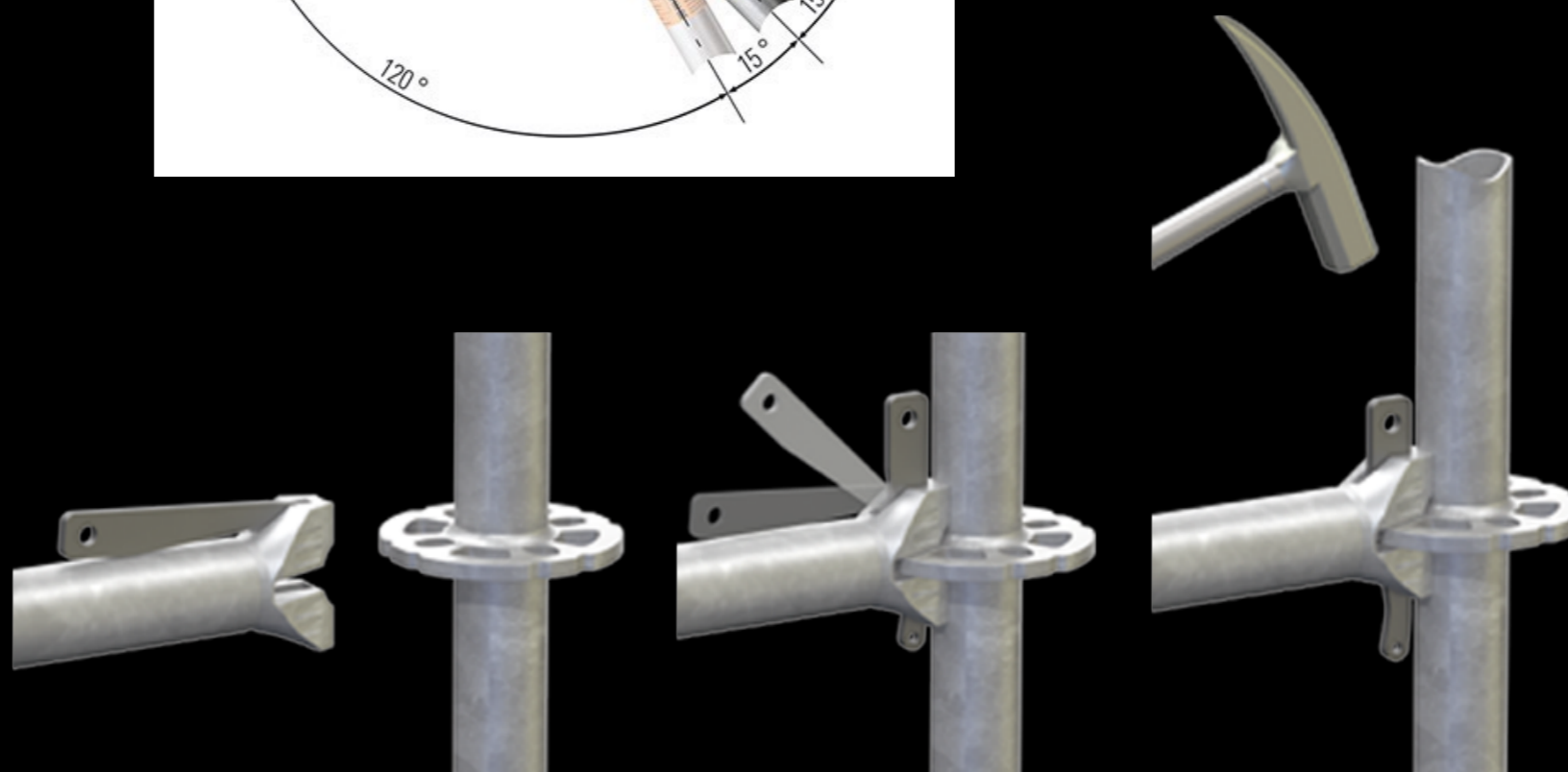
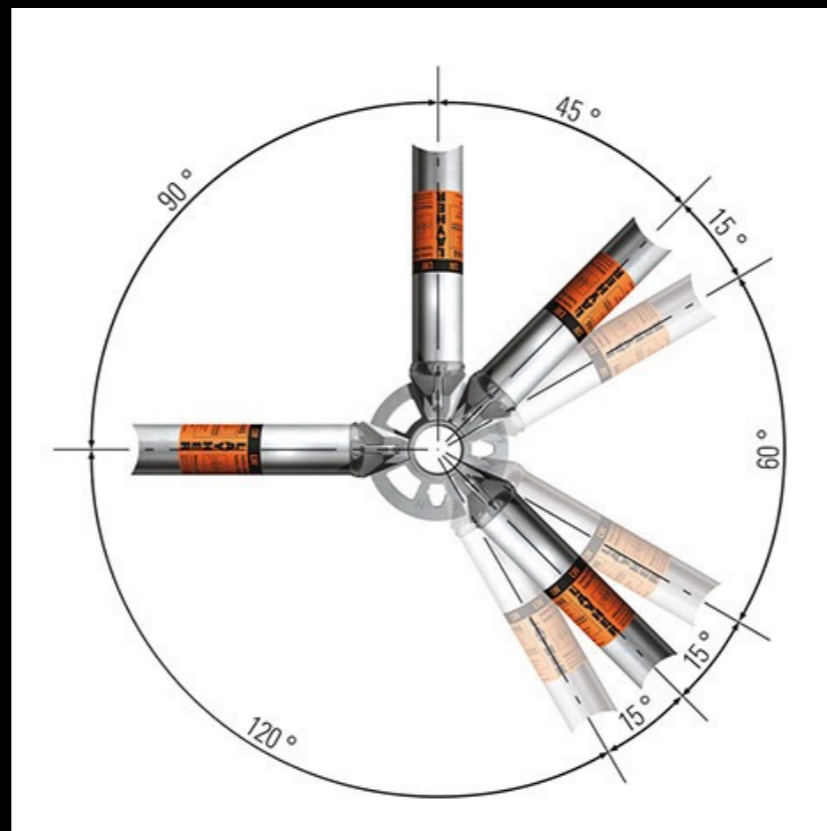
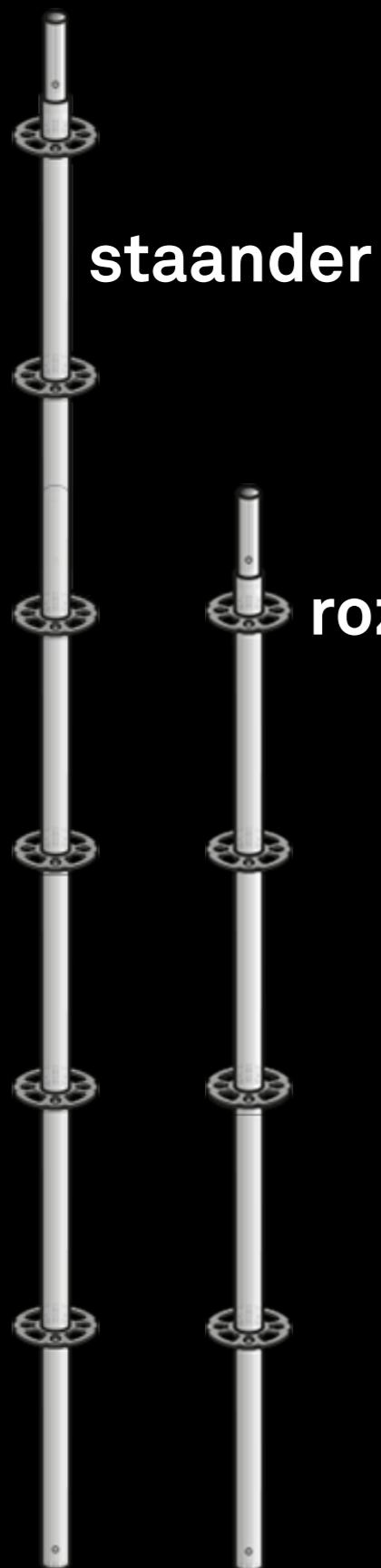

steigerwerk

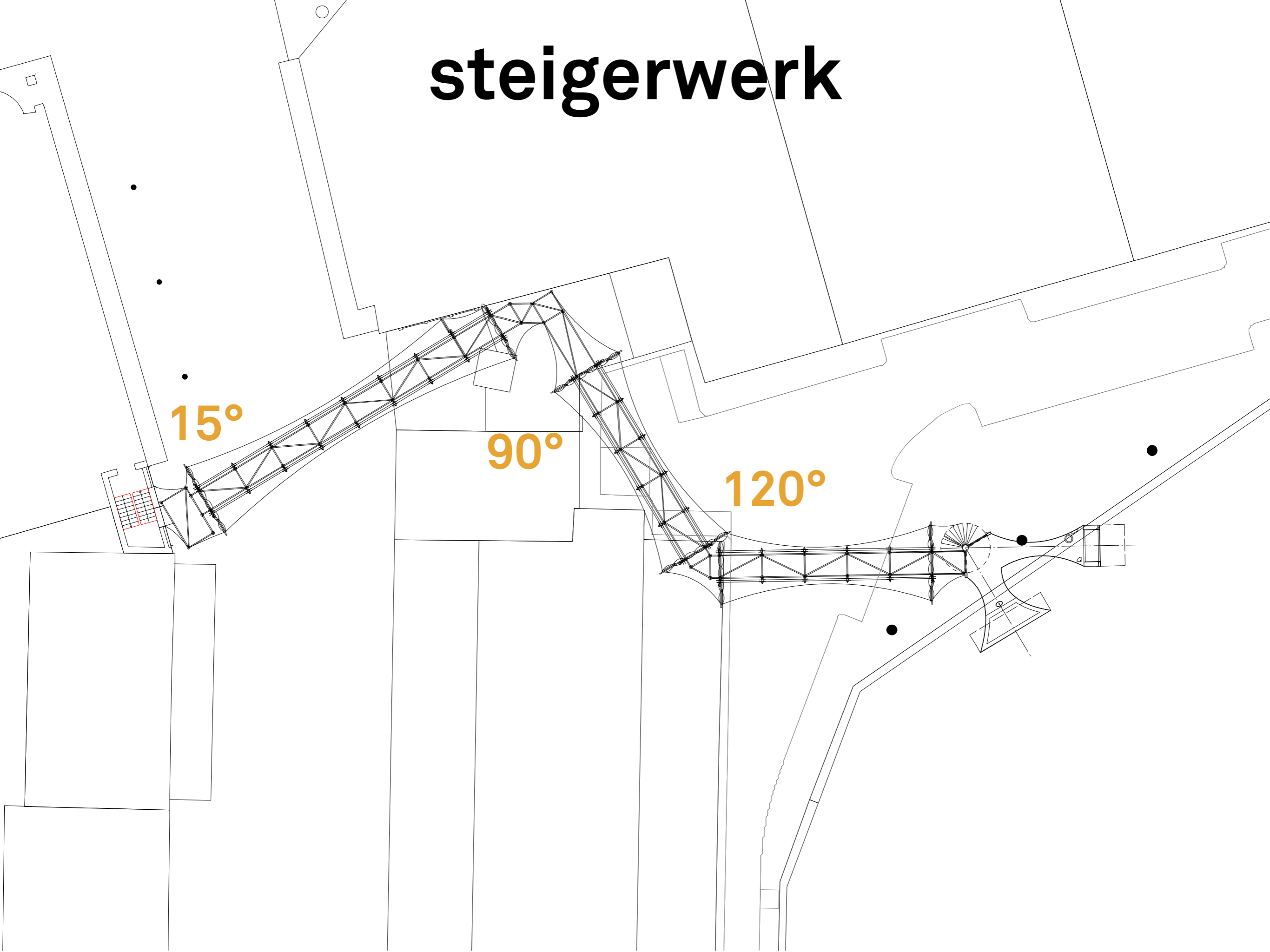

steigerwerk



BENSORE
FOR ARMY GU... SECURITY & MORE
3400 SHOPPER OP
WWW.BENSORE.COM

P Quax
→
KOOPGOOT



entree

Nooduitgang
vrijlaten a.u.b.

nooduitgang



trap

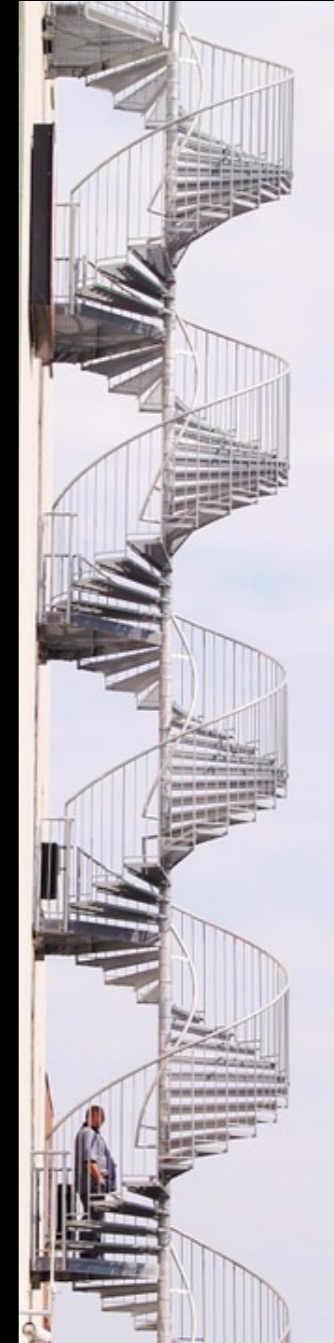

brug

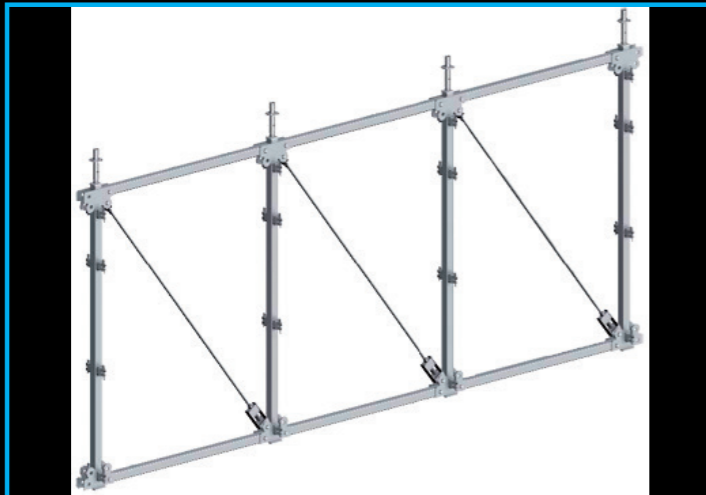

Lather Multi inzetbare voetgangersbrug

brug

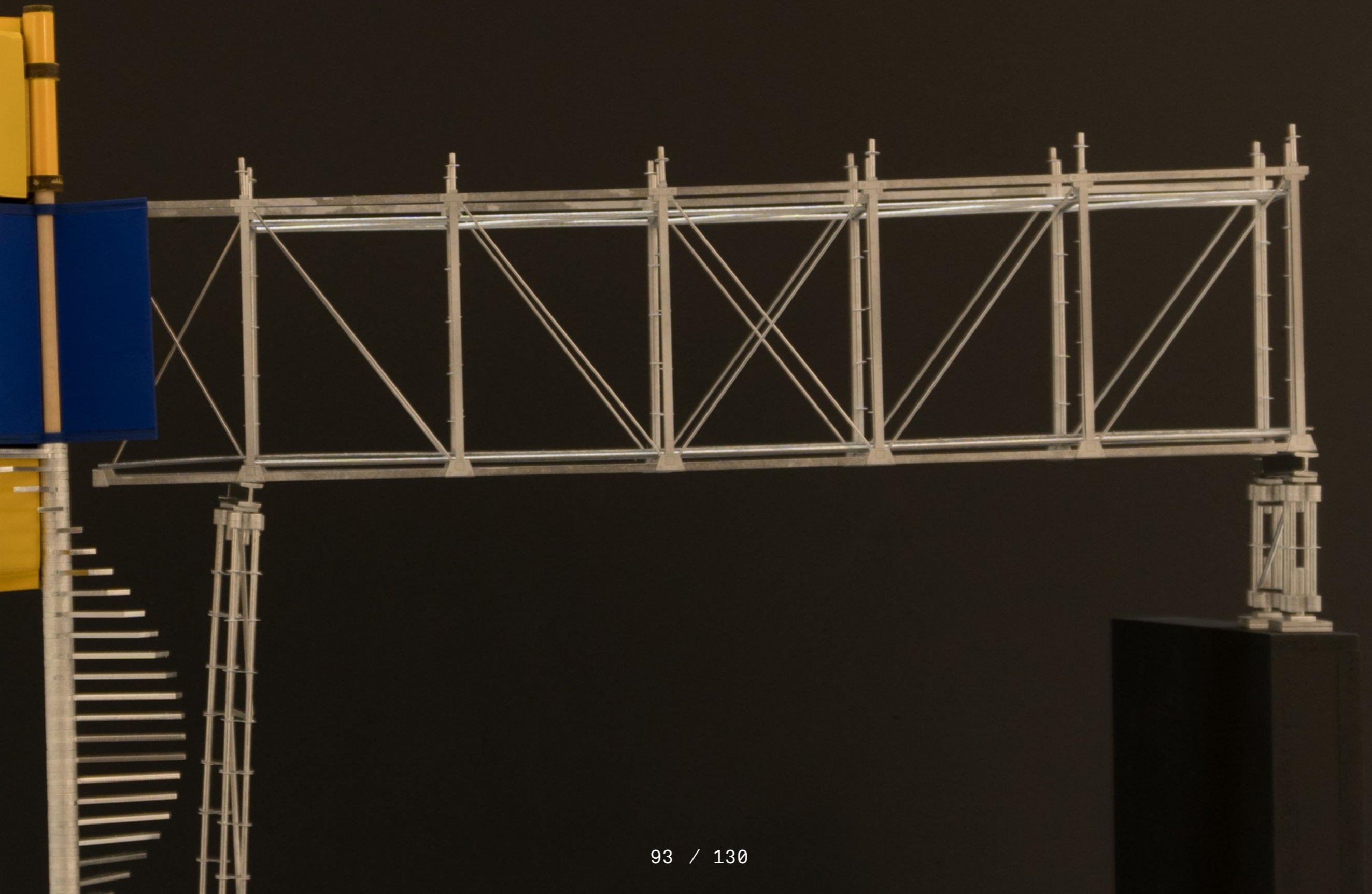

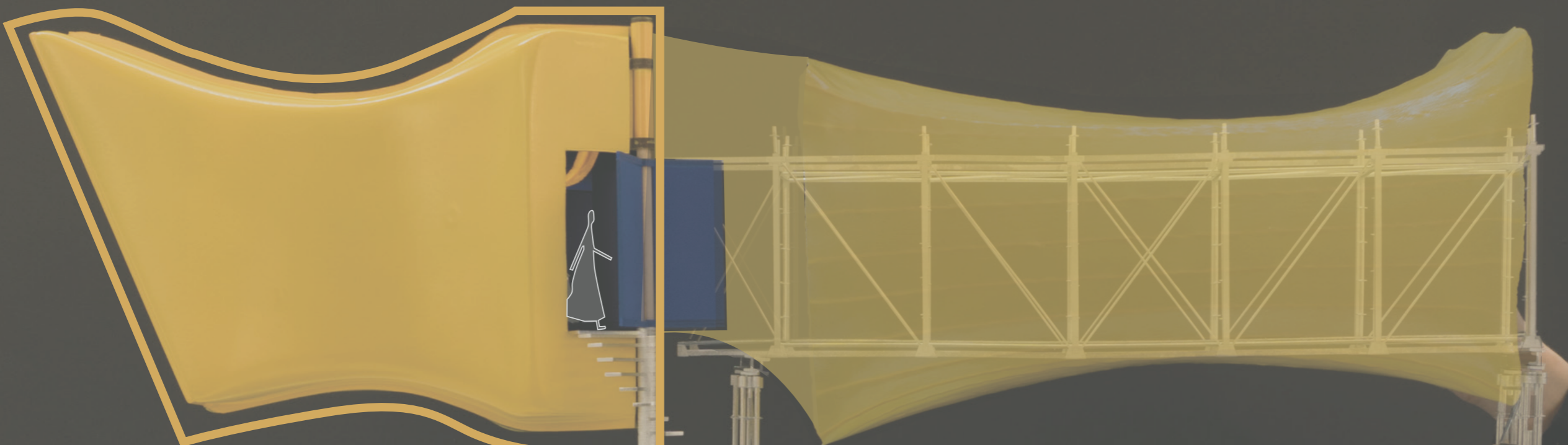

toilet unit



toilet unit



Glasvezelversterkte polyester boot



Glasvezelversterkte polyester toilet unit

toilet unit

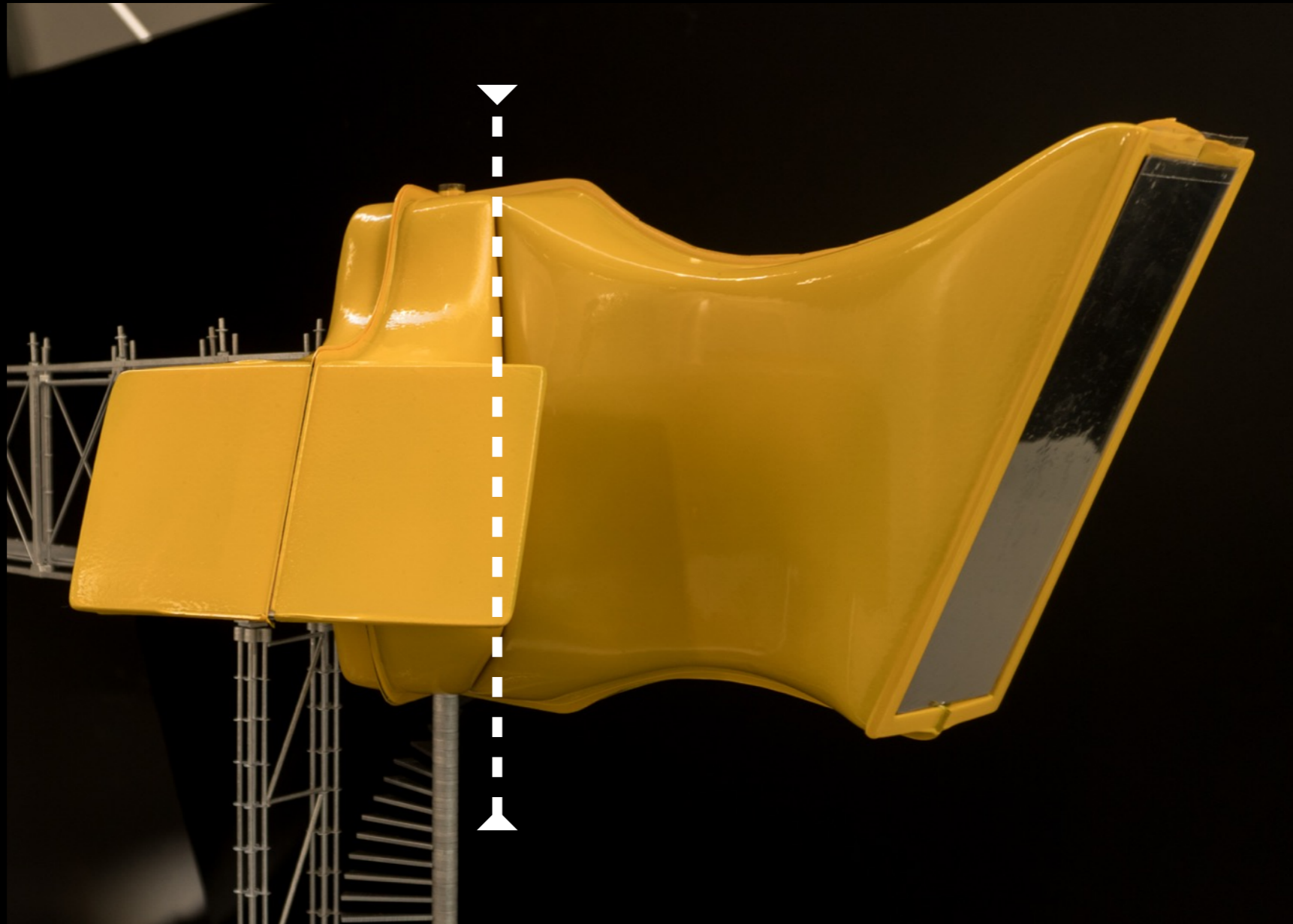

klimaat

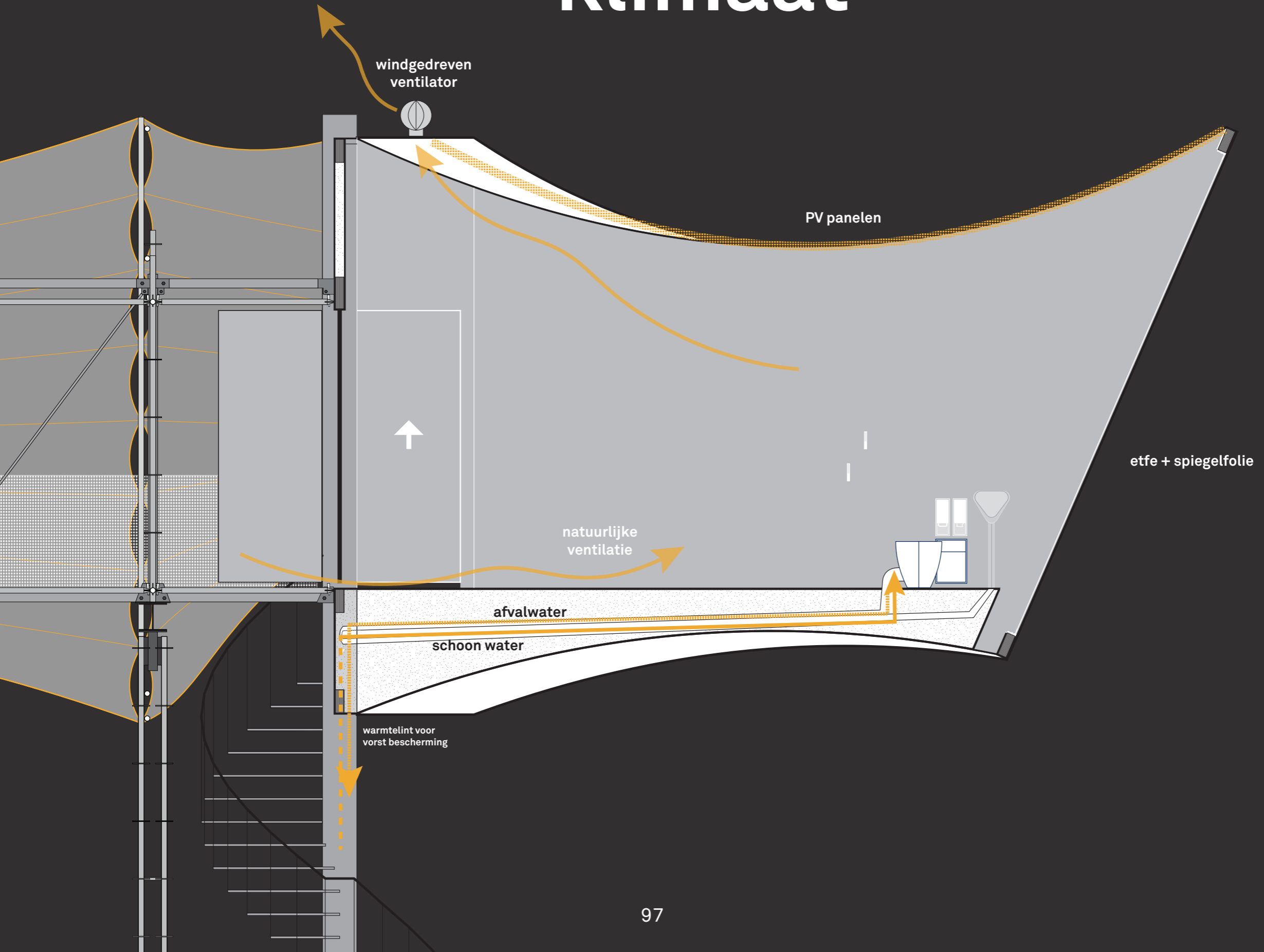

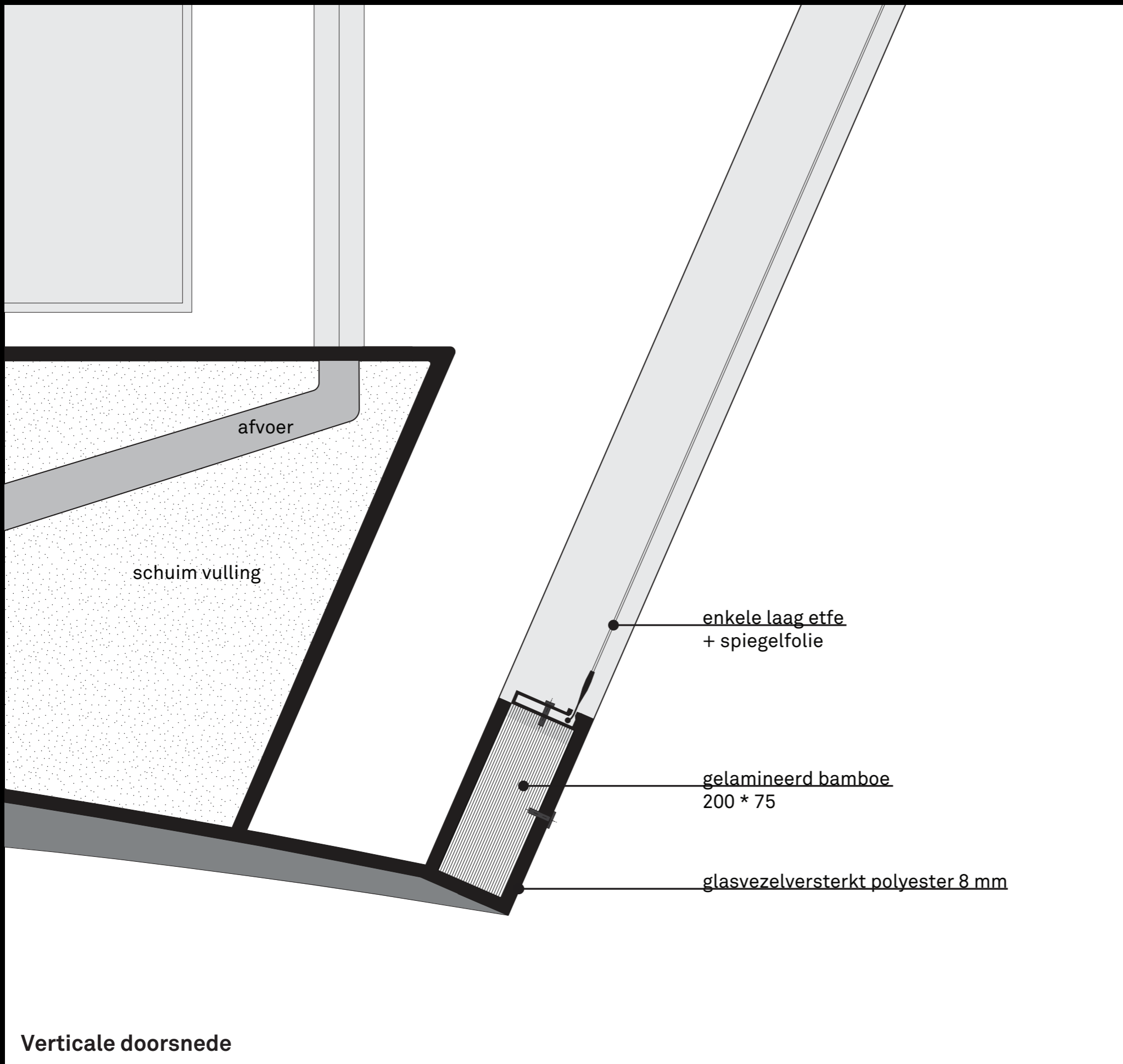

Verticale doorsnede

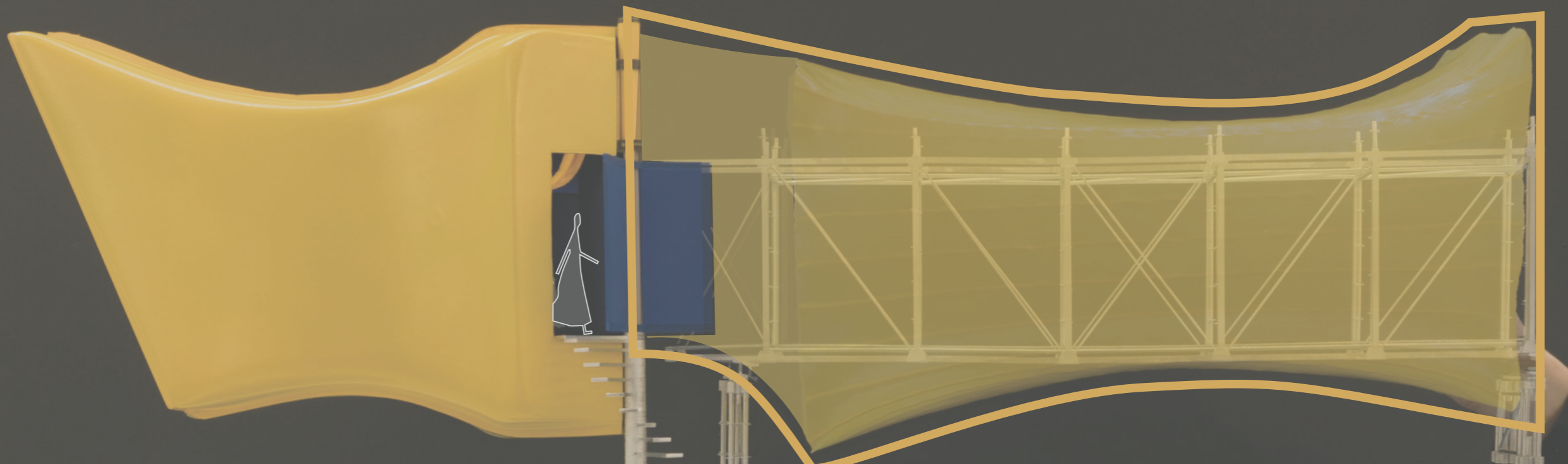

tunnel



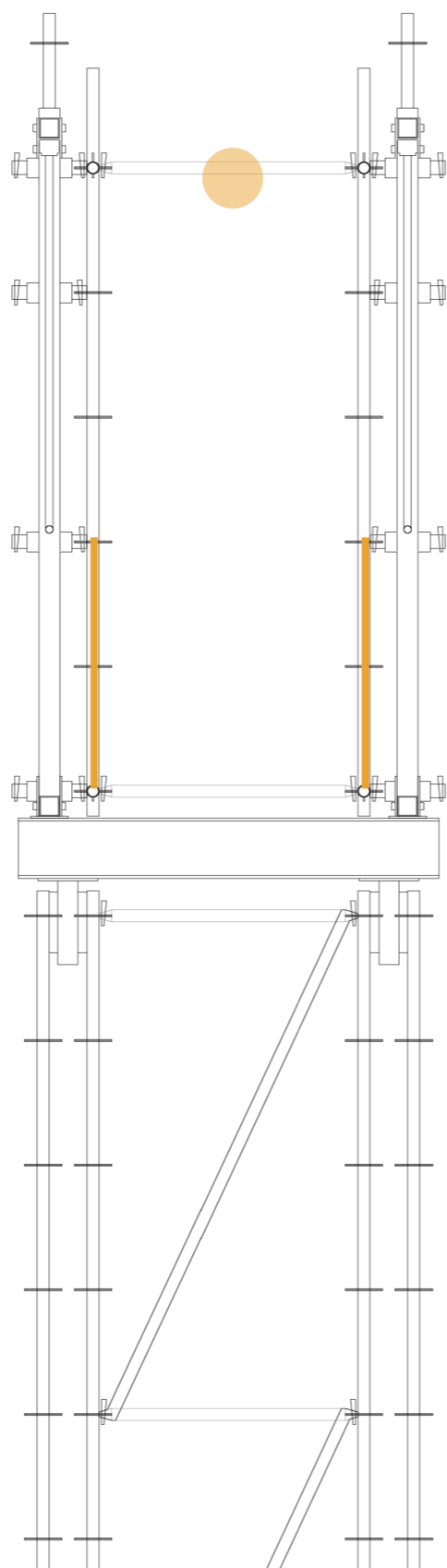

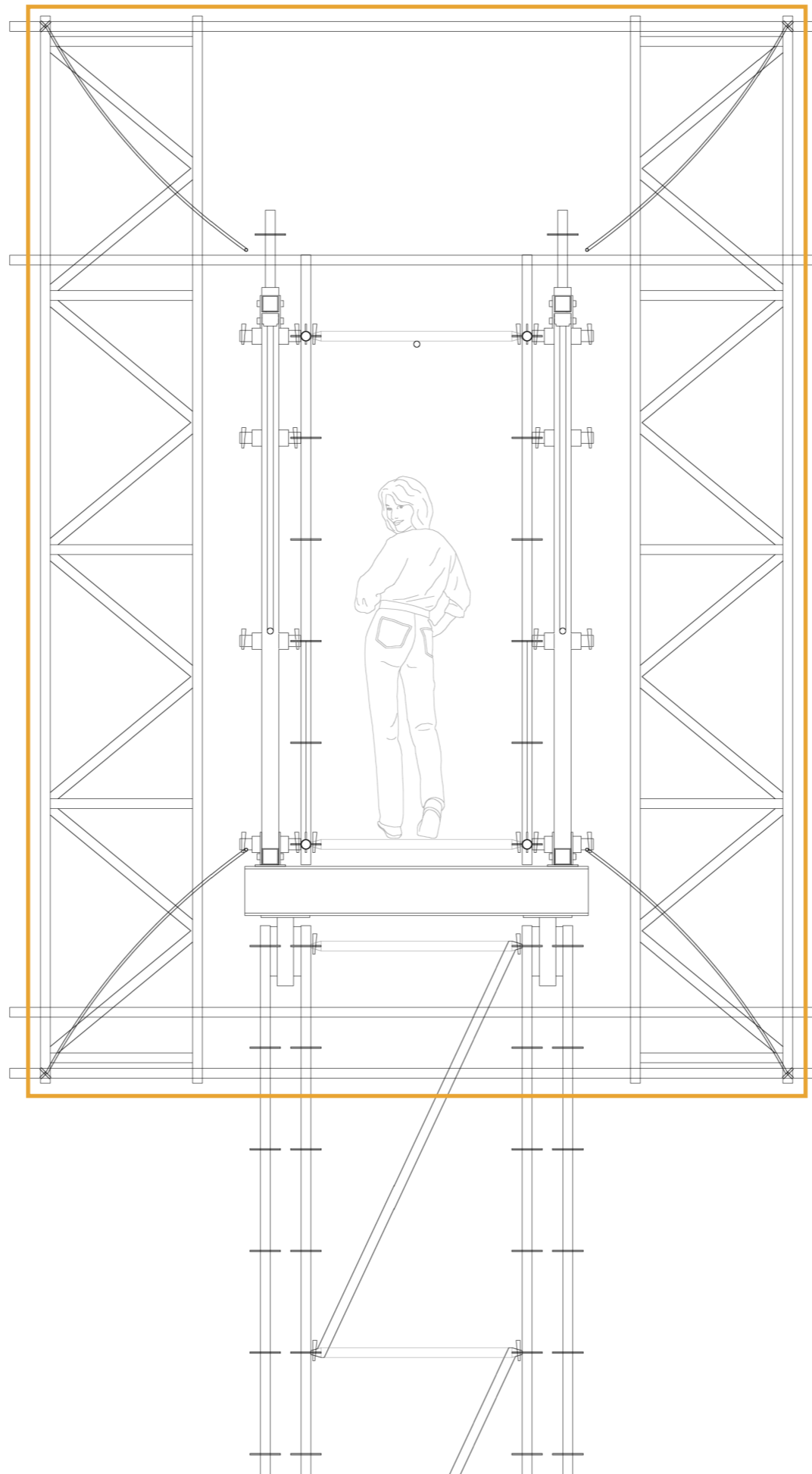

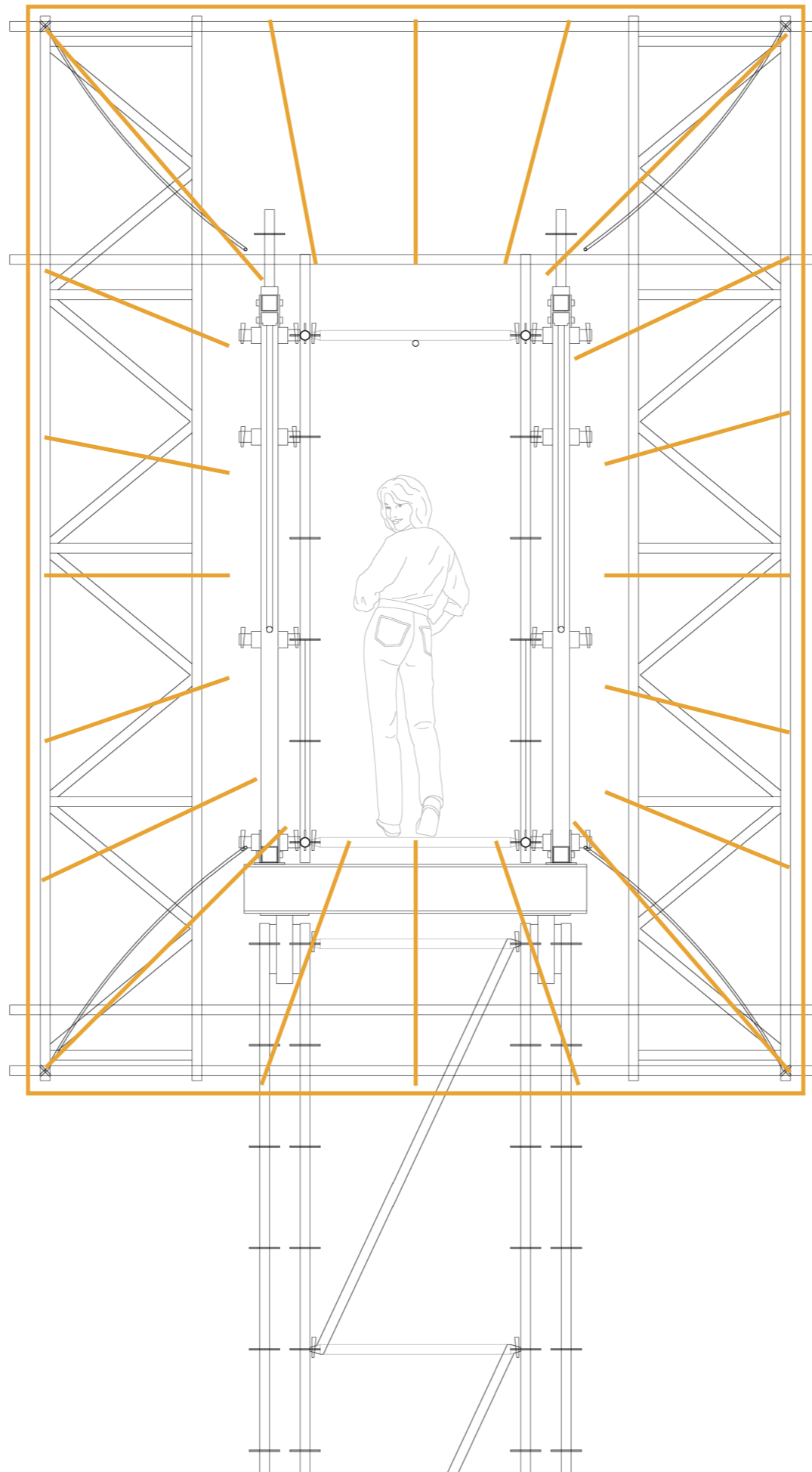

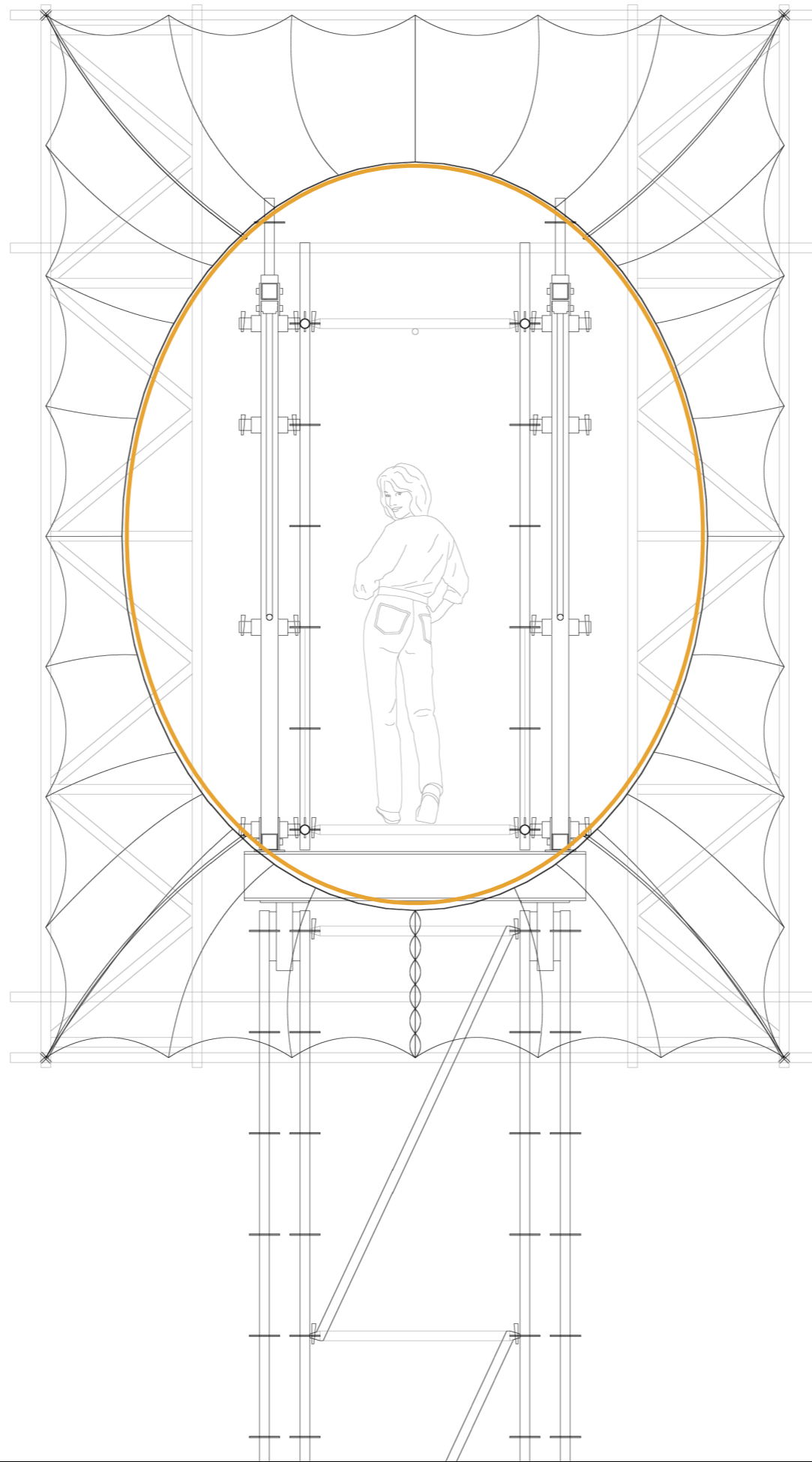



opbouw

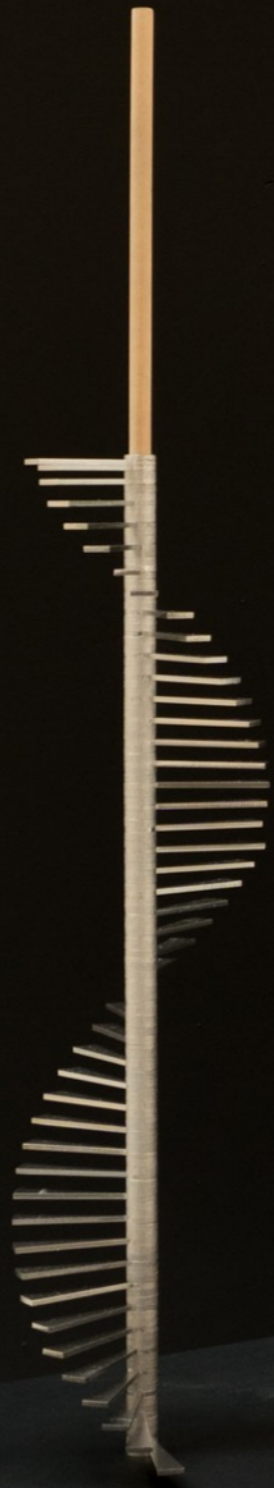

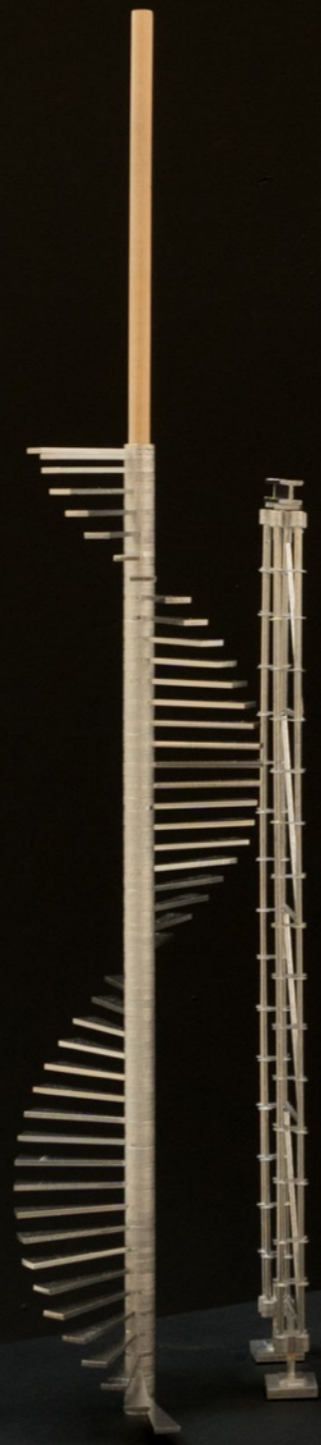



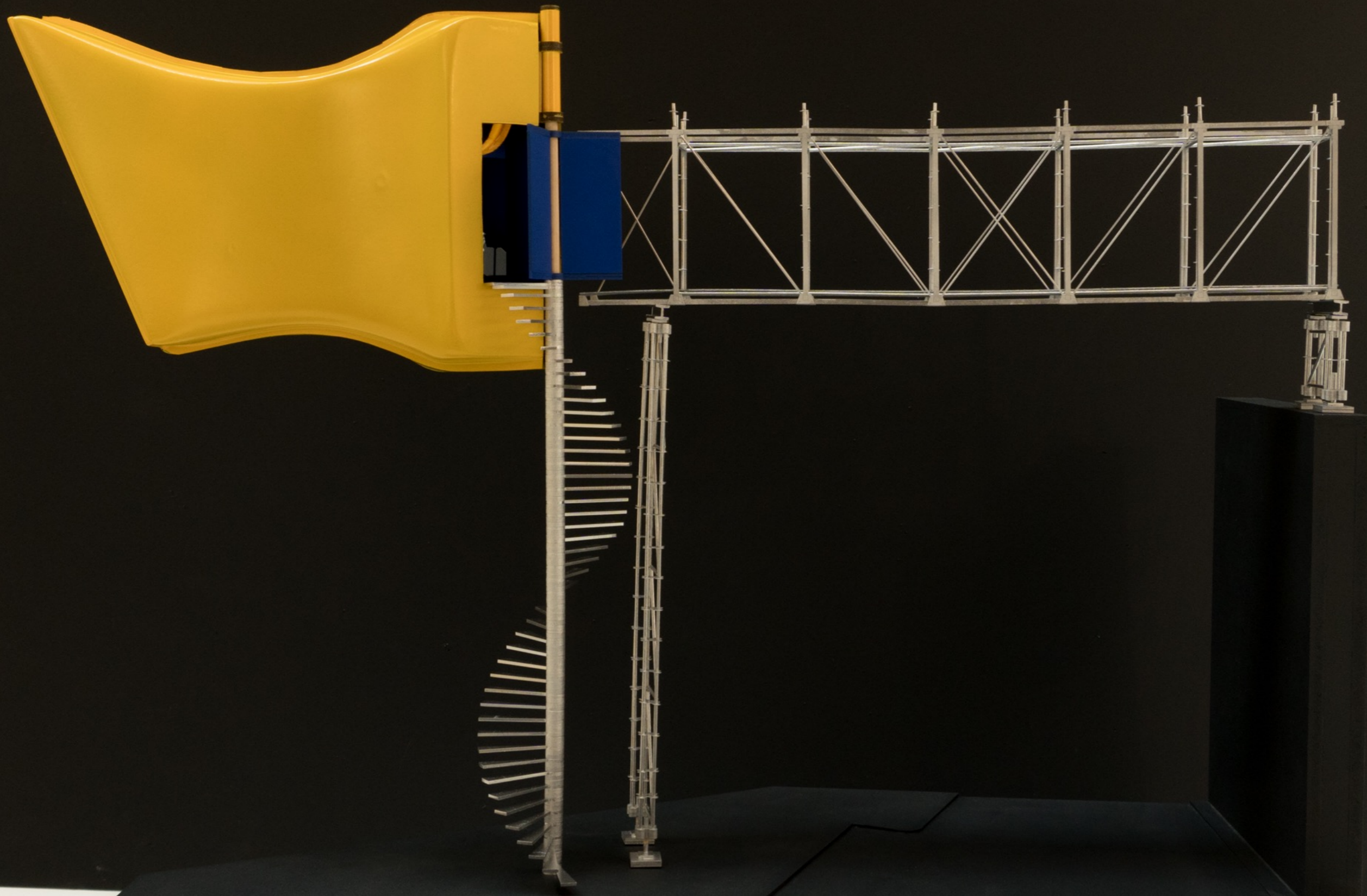

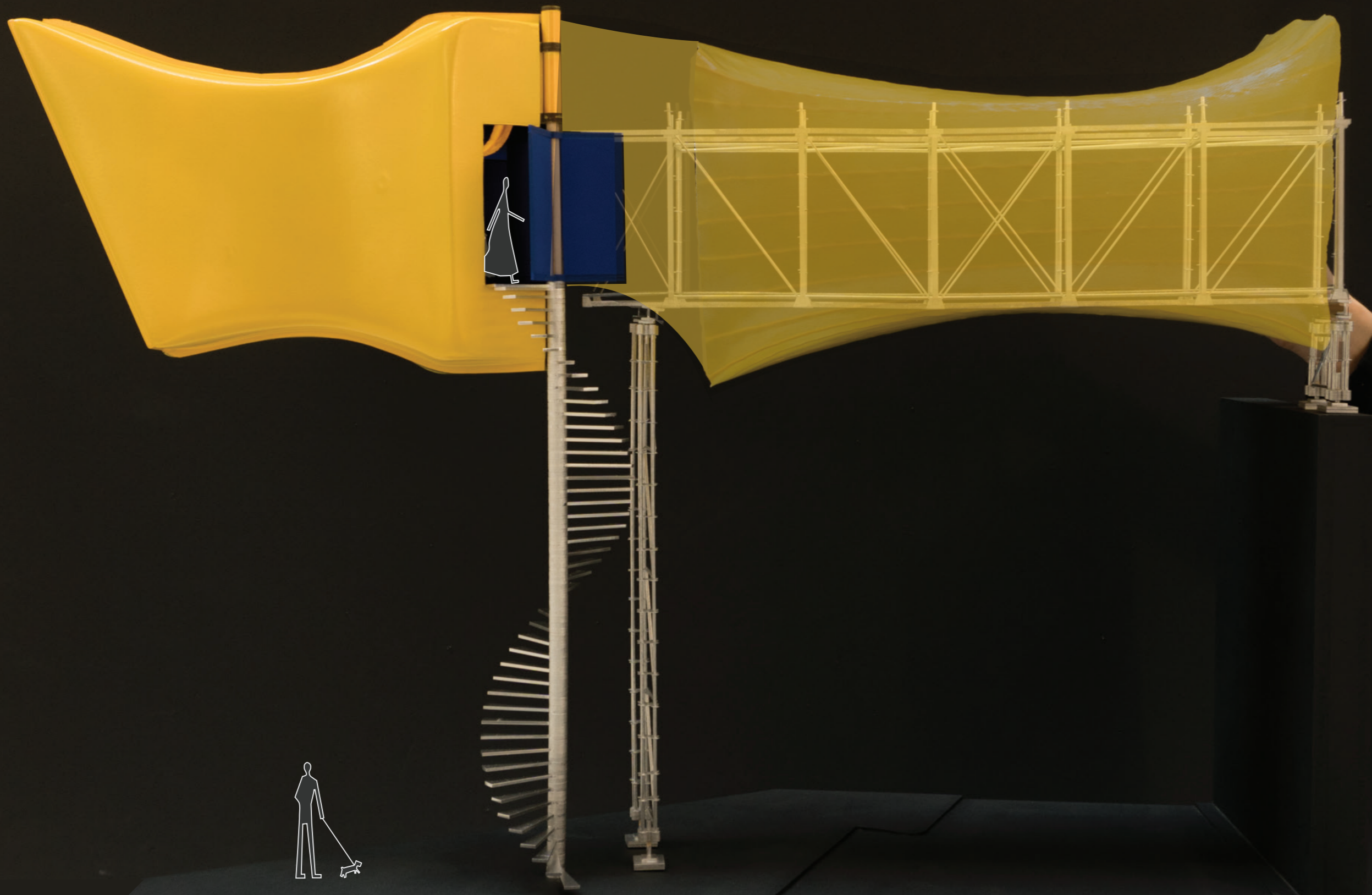

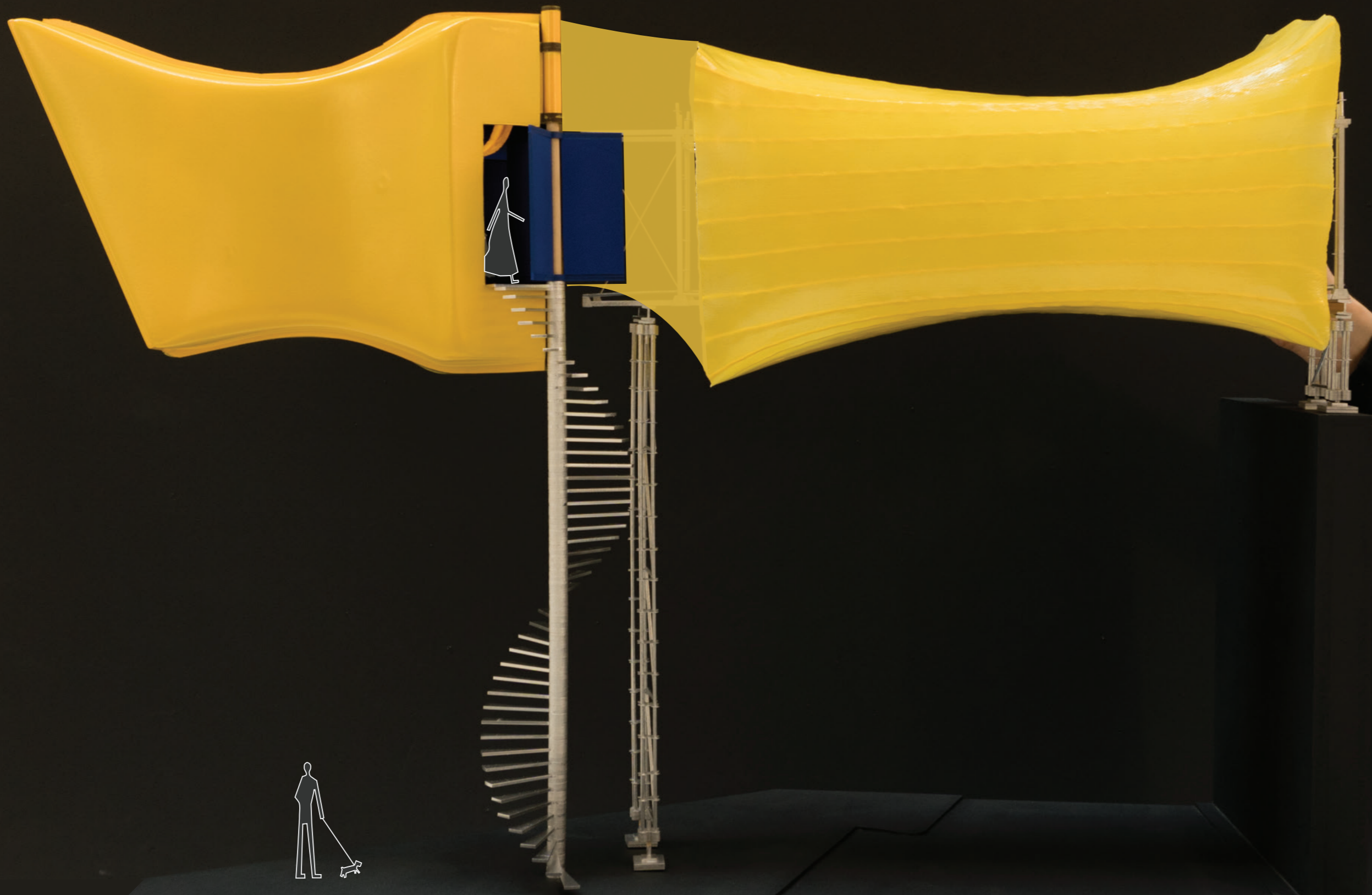



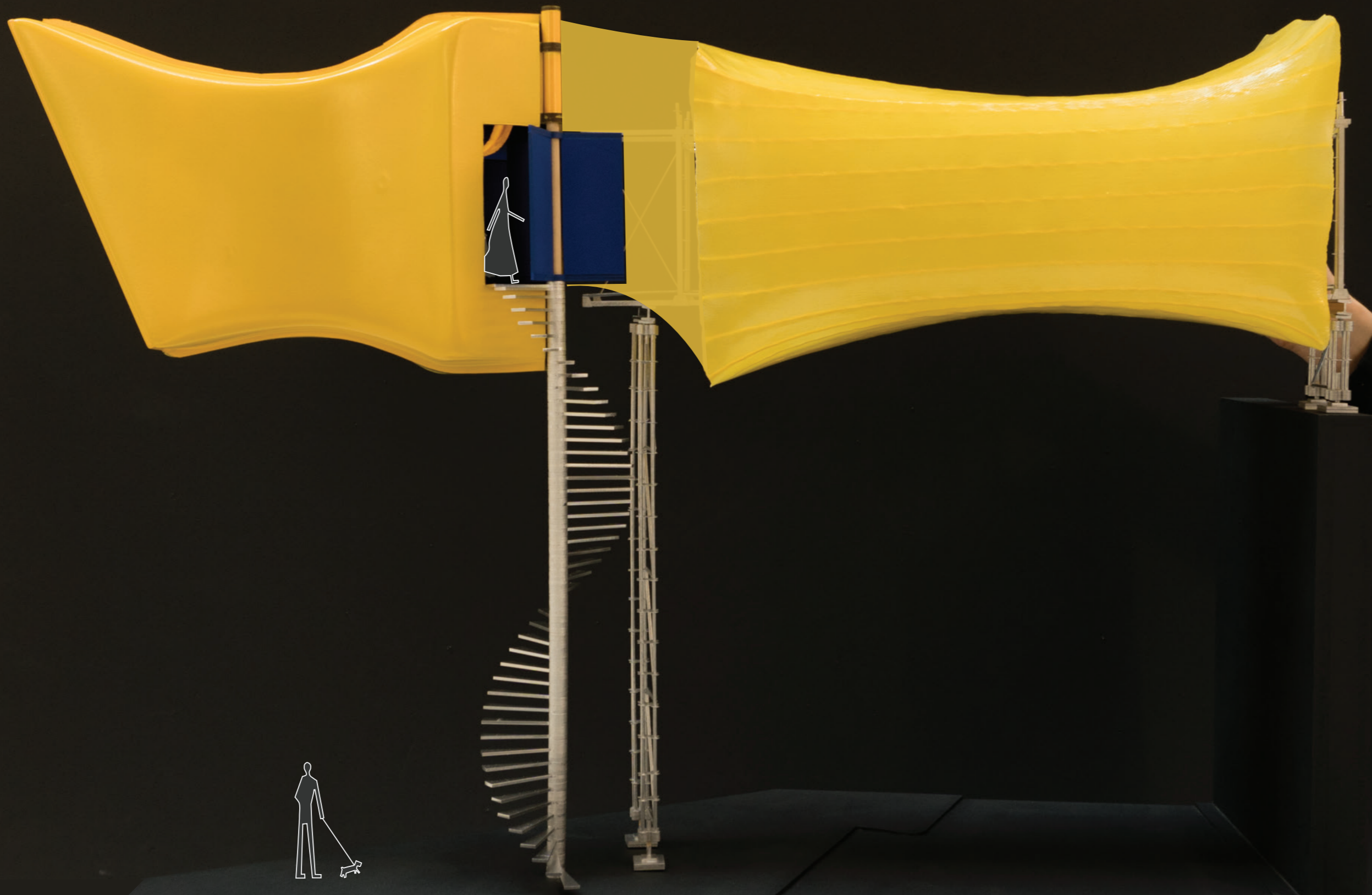

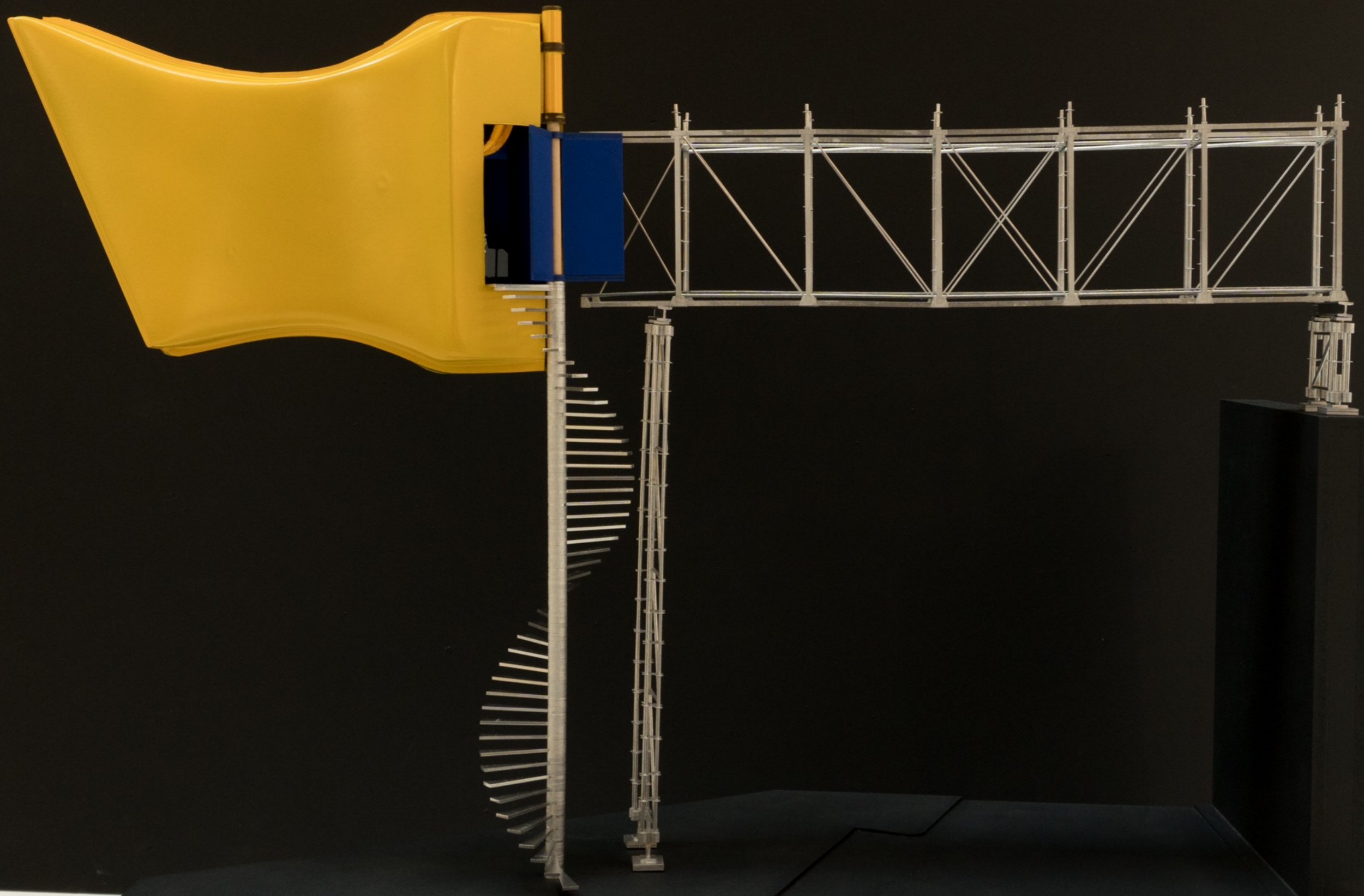



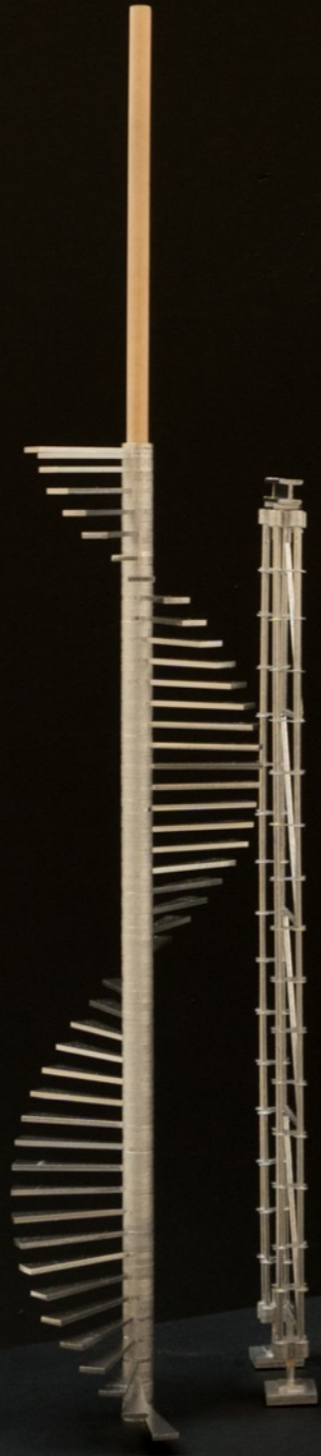

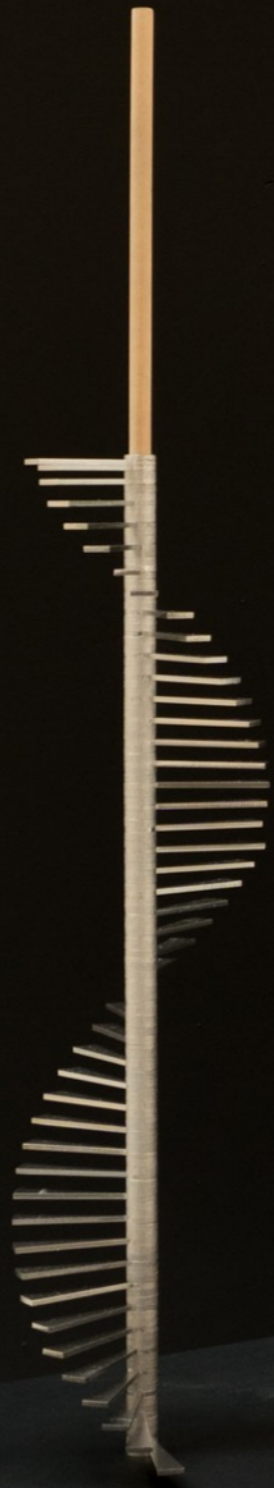



danku









danku

p-five | yara valente | april 16th 2019

tutors: roel van de pas, willemijn wilms floet, hubert van der meel
external: daan vitner

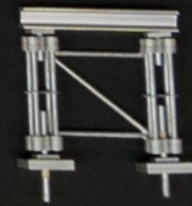
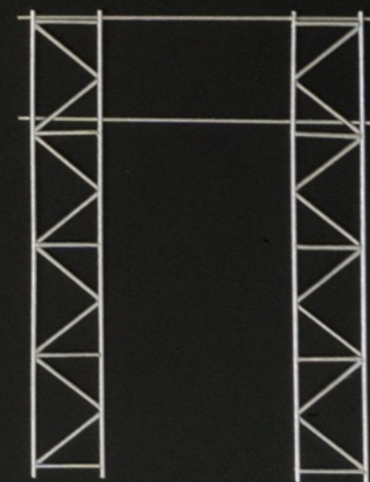
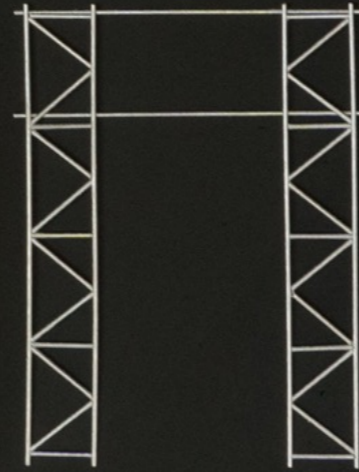
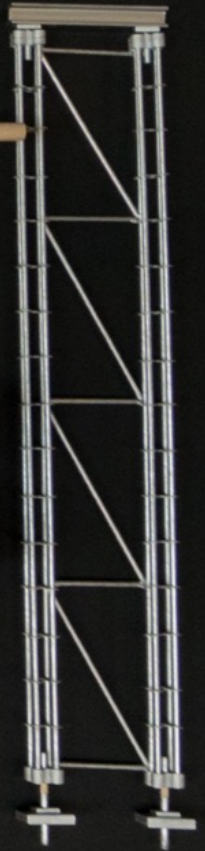
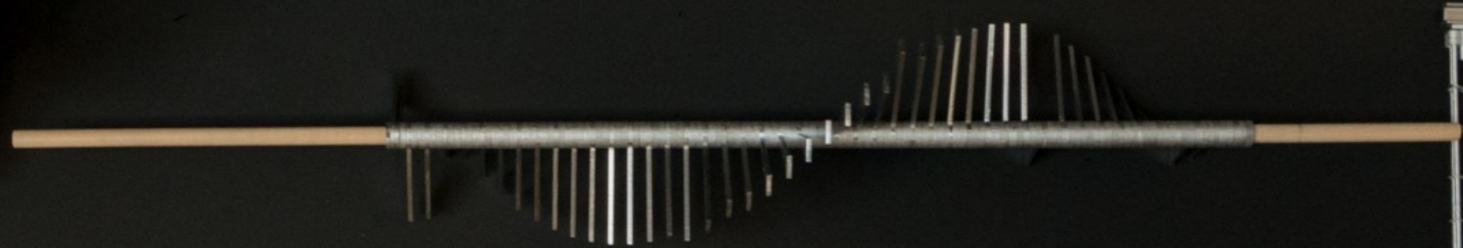
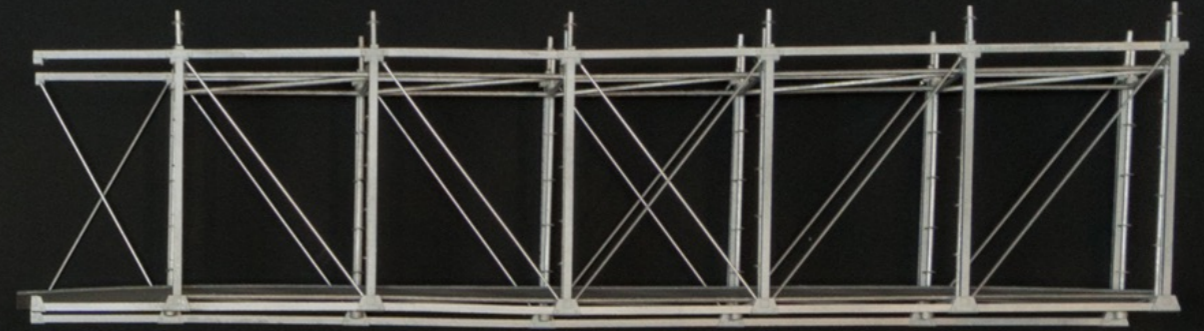





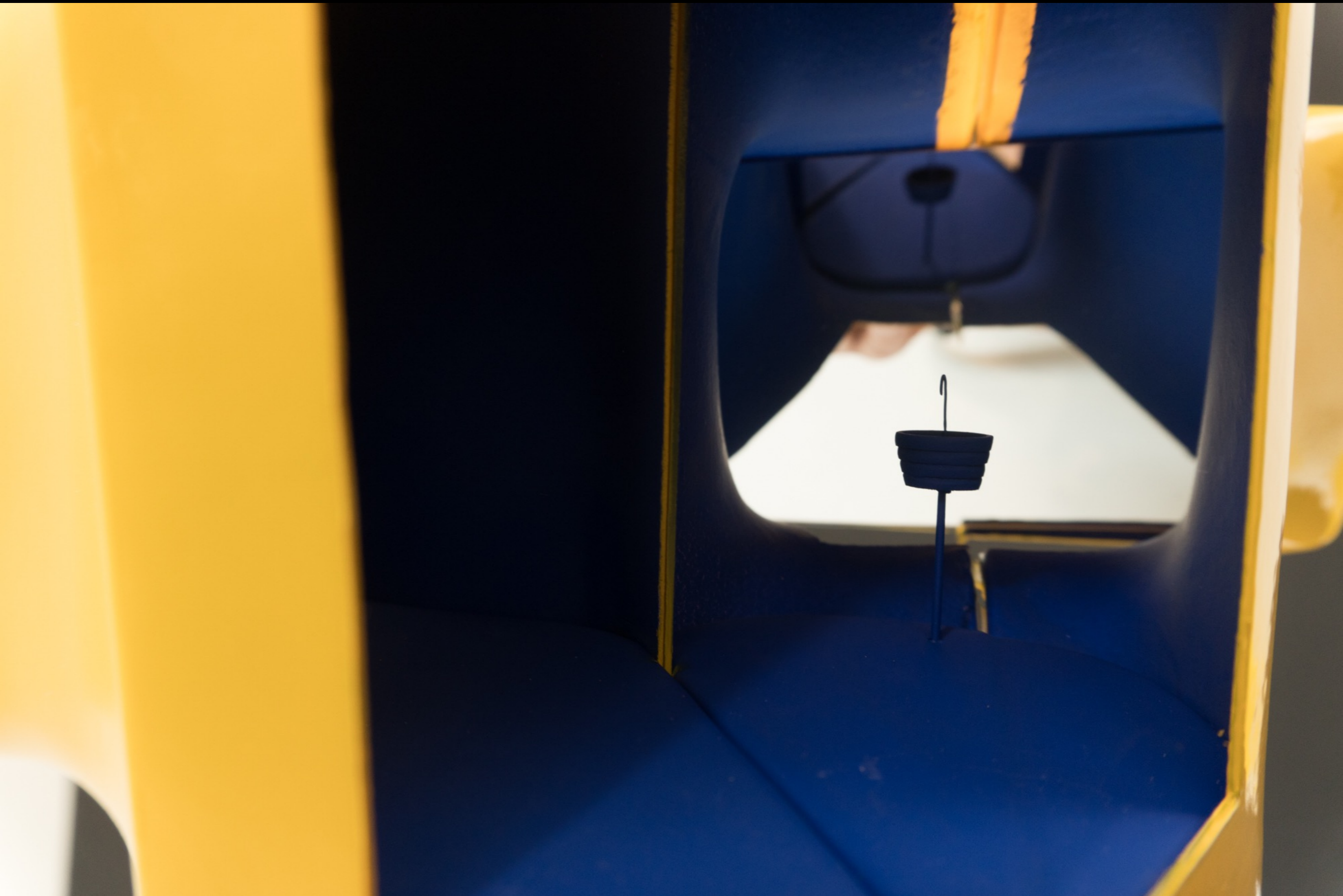

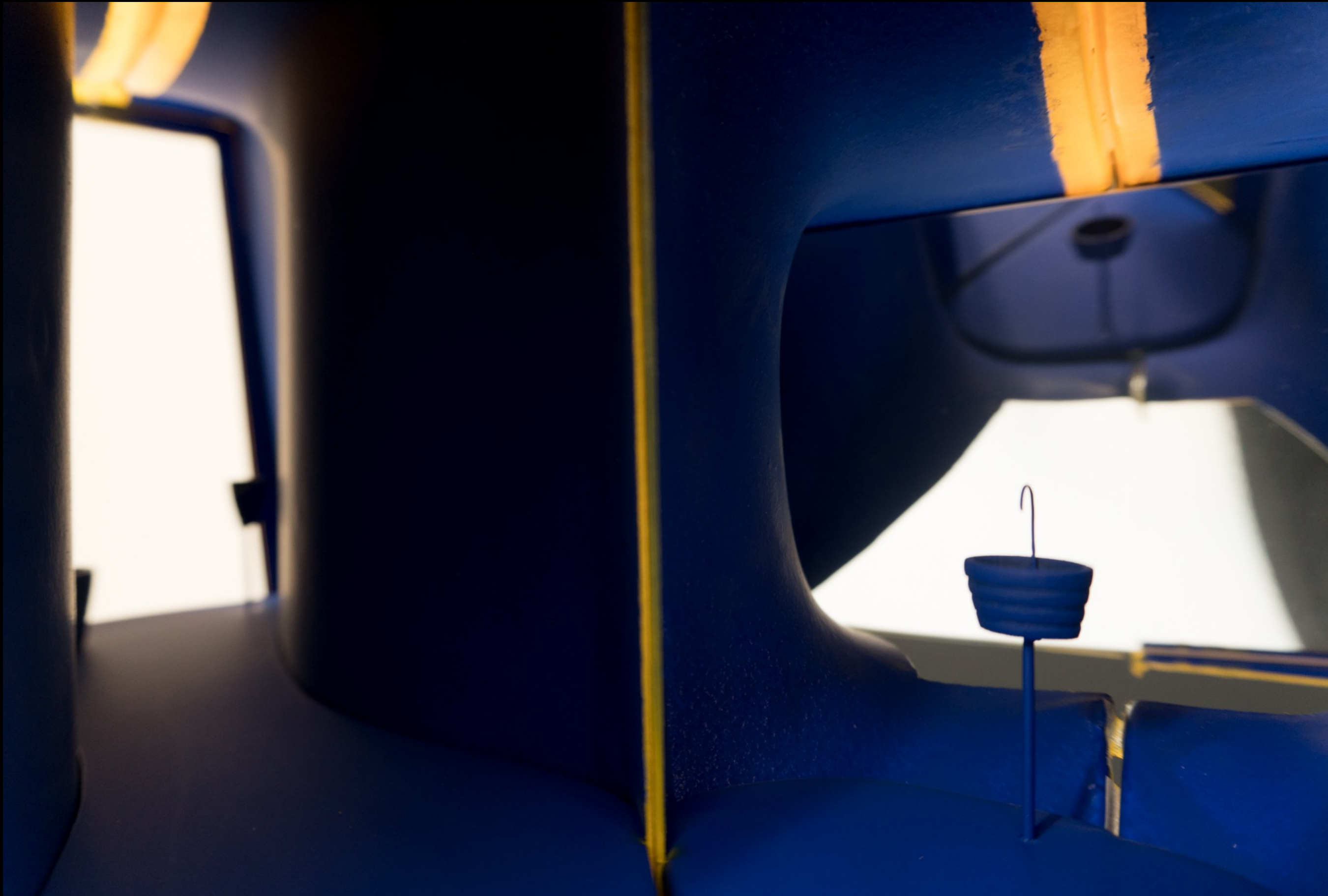



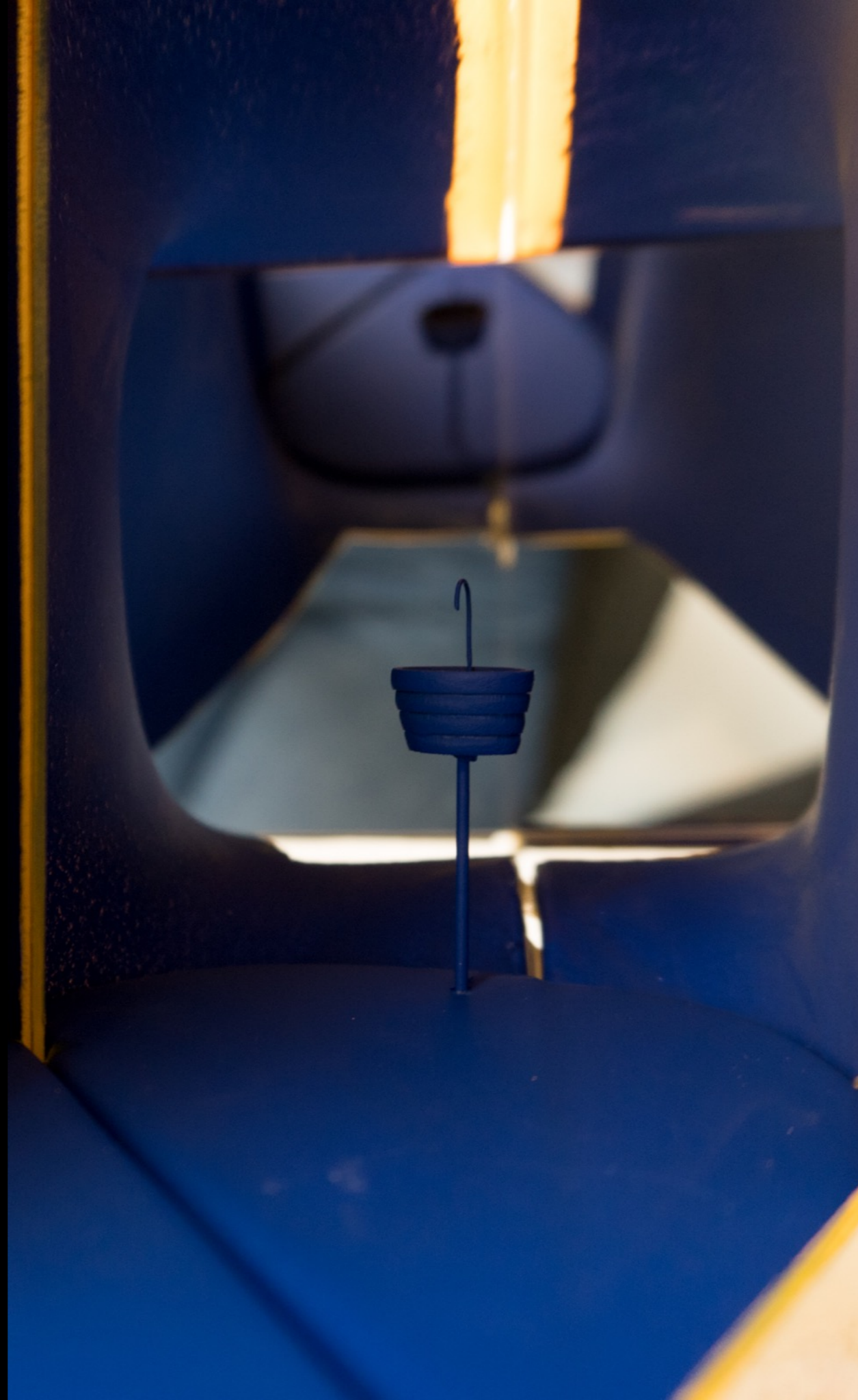

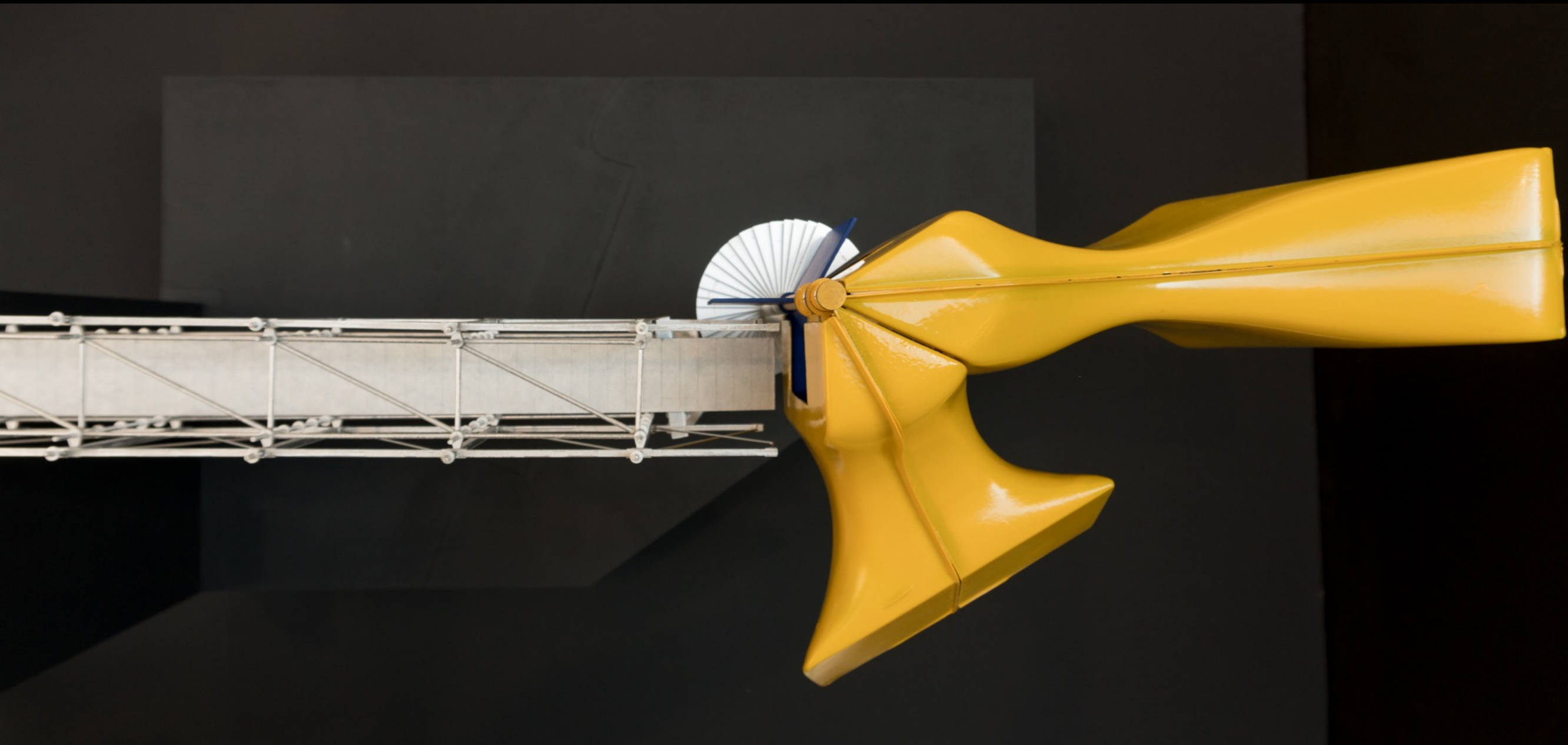

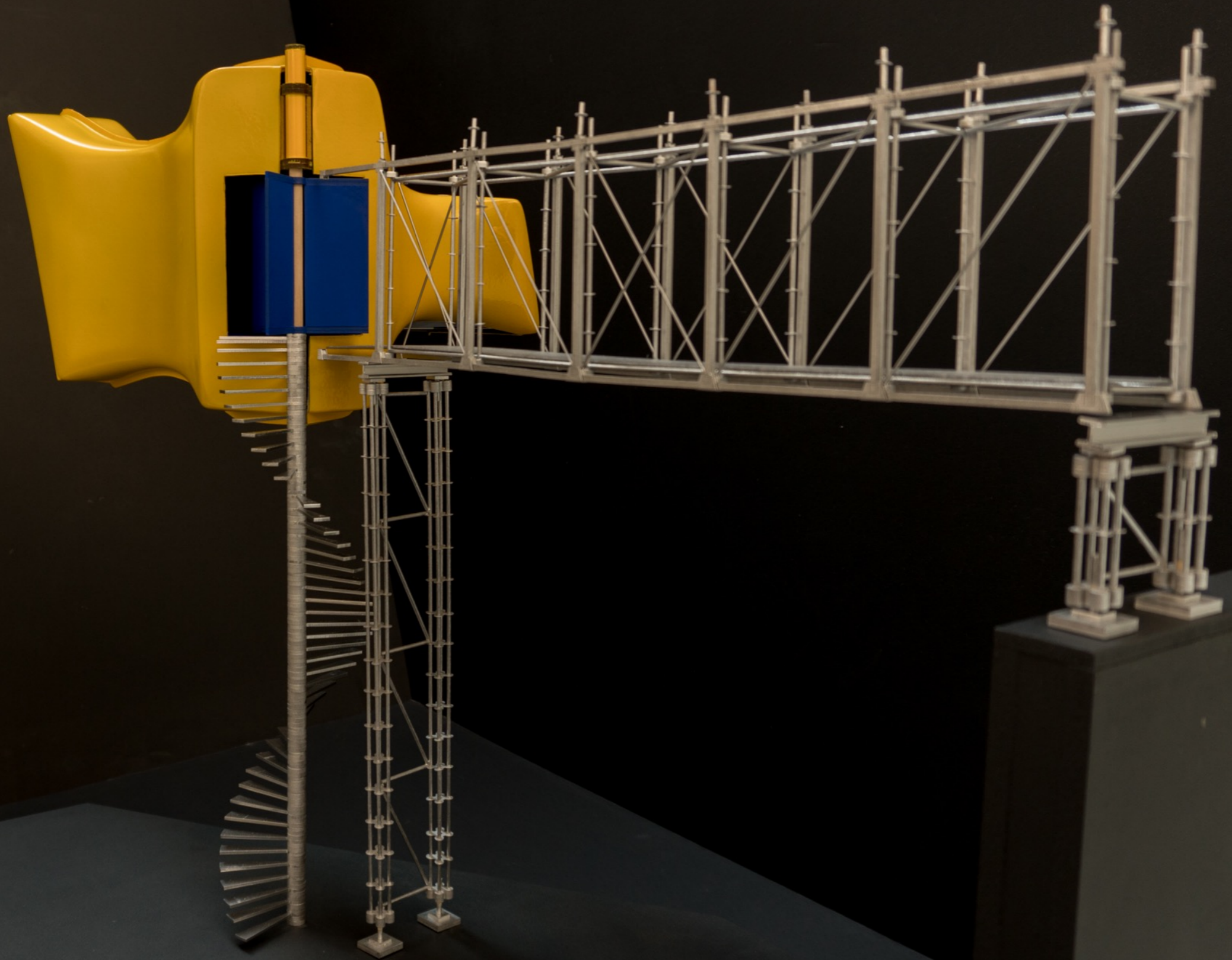



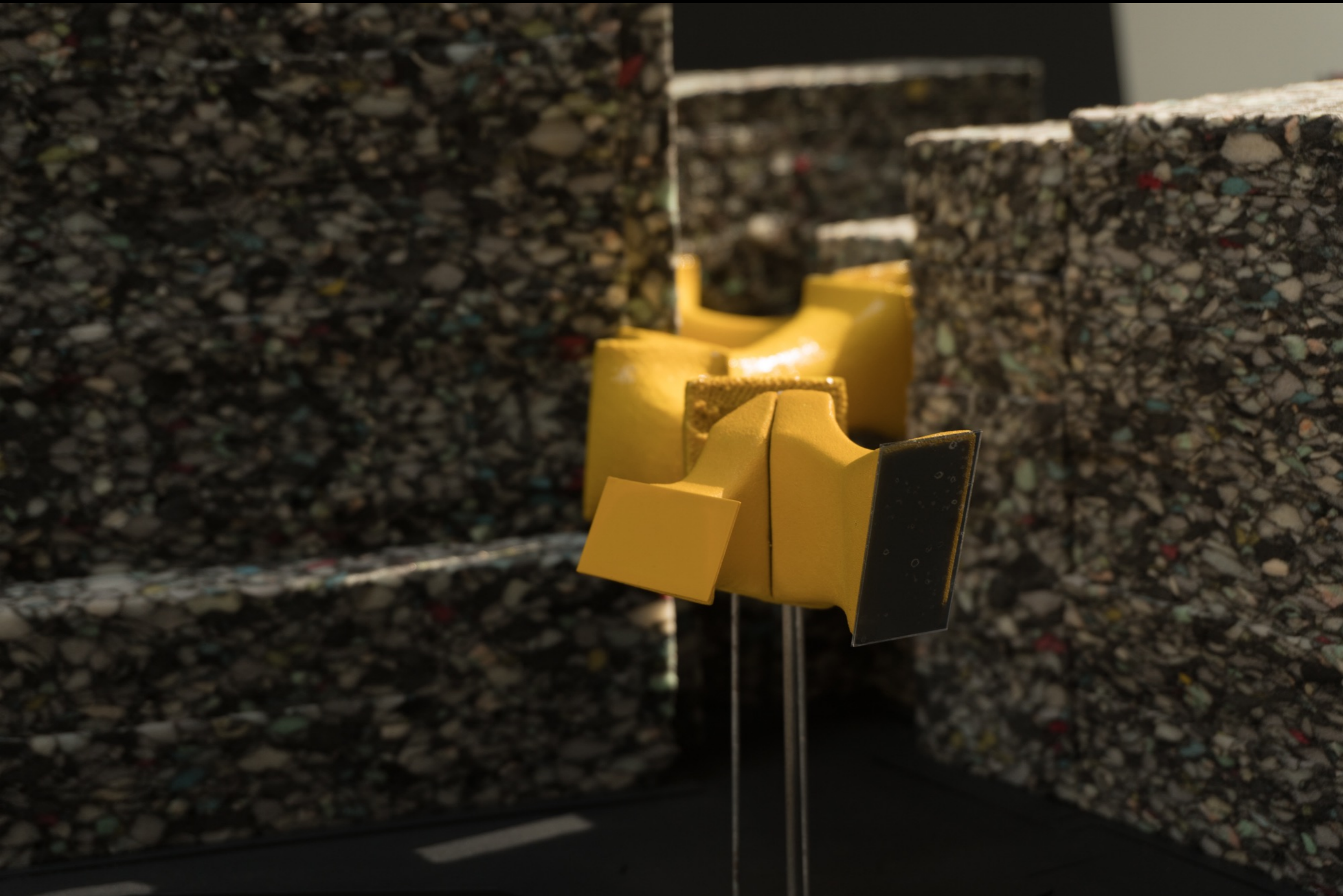







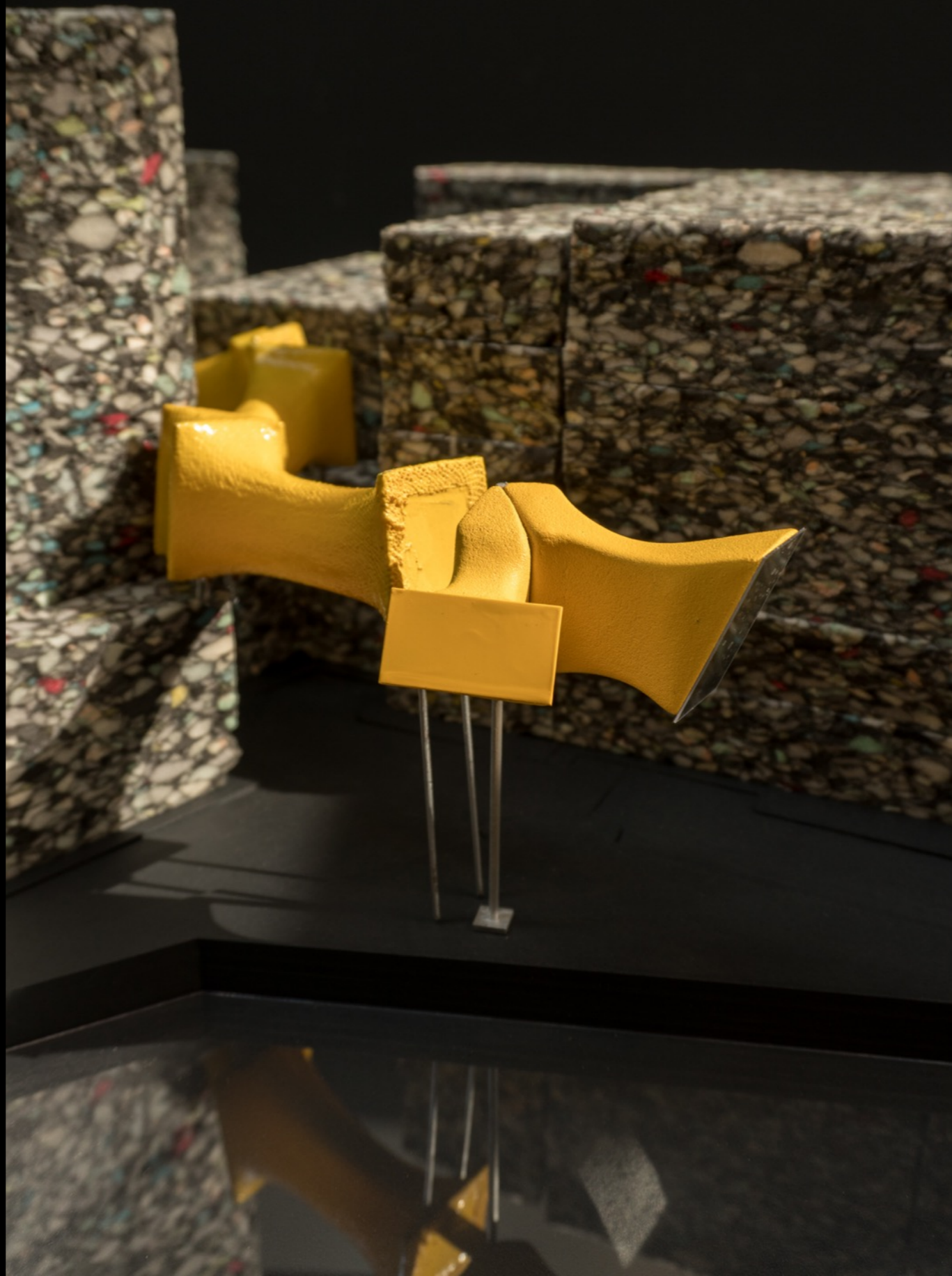

Detail 1
1:5

draaideur

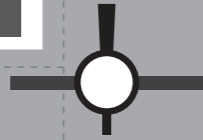

Aanzicht

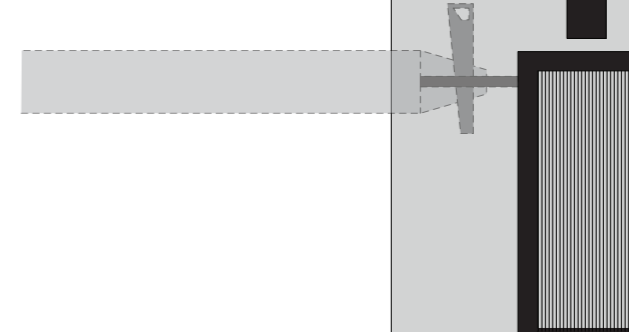

polyester vloer ingestrooid met zand voor antislip

draaideur

glasvezelversterkt polyester 8 mm

gelamineerd bamboe
200 * 75

rozet verbinding

tunnel doek

stalen vlonder
buisoplegging gestanst

Horizontale doorsnede

Verticale doorsnede